

Service Manual

DV7010 /A1B, /A1G, /C1G, /L1G, /N1B, /N1G, /F1N, /S1G, /U1B
 DV18A /A1B, /A1G, /C1G, /K1G, /S1G, /L1G, /U1B
 DV17 /N1B, /N1G, /F1N, /S1G
 DVD Player

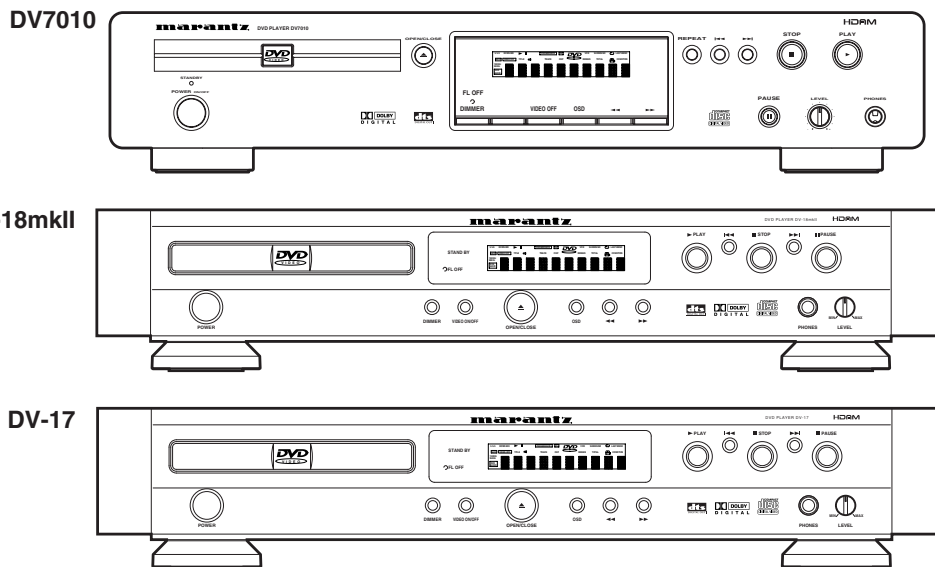

TABLE OF CONTENTS

SECTION	PAGE
1. MAIN UNIT	
1.1 TECHNICAL SPECIFICATIONS	1-1
1.2 CONNECTION FACILITIES	1-2
1.3 INFORMATIONS	1-3
1.4 SERVICING HINT	1-4
1.5 DISASSEMBLY	1-5
1.6 SERVICE MODE	1-7
1.7 WAVEFORM	1-8
1.8 WIRING DIAGRAM	1-9
1.9 BLOCK DIAGRAM	1-11
1.10 SCHEMATIC DIAGRAM AND PARTS LOCATION	1-13
1.11 PARTS LOCATION	1-23
1.12 MICROPROCESSOR AND IC DATA	1-30
1.13 EXPLODED VIEW AND PARTS LIST	1-33
1.14 ELECTRICAL PARTS LIST	1-41
2. DB-VLD210 (DVD Loader for MARANTZ)	
3. DB-VPB210 / 211 / 212 / 213 / 214 (DVD PCB Module for MARANTZ)	

Please use this service manual with referring to the user guide (D.F.U) without fail.
 修理の際は、必ず取り扱い説明書を準備し操作方法を確認の上作業を行ってください。

marantz®

DV7010 / DV-18mkII / DV-17

403K855010 ACT
 3120 785 22490
 First Issue 2001.04

MARANTZ DESIGN AND SERVICE

Using superior design and selected high grade components, **MARANTZ** company has created the ultimate in stereo sound. Only original **MARANTZ** parts can insure that your **MARANTZ** product will continue to perform to the specifications for which it is famous.

Parts for your **MARANTZ** equipment are generally available to our National Marantz Subsidiary or Agent.

ORDERING PARTS :

Parts can be ordered either by mail or by Fax.. In both cases, the correct part number has to be specified.

The following information must be supplied to eliminate delays in processing your order :

1. Complete address
2. Complete part numbers and quantities required
3. Description of parts
4. Model number for which part is required
5. Way of shipment
6. Signature : any order form or Fax. must be signed, otherwise such part order will be considered as null and void.

USA

MARANTZ AMERICA, INC.
440 MEDINAH ROAD
ROSELLE, ILLINOIS 60172
USA
PHONE : 630 - 307 - 3100
FAX : 630 - 307 - 2687

EUROPE / TRADING

MARANTZ EUROPE B.V.
P.O.BOX 80002, BUILDING SFF2
5600 JB EINDHOVEN
THE NETHERLANDS
PHONE : +31 - 40 - 2732241
FAX : +31 - 40 - 2735578

BRAZIL

PHILIPS DA AMAZONIA IND. ELET. ITDA
CENTRO DE INFORMACOES AO
CEP 04698-970
SAO PAULO, SP, BRAZIL
PHONE : 0800 - 123123(Discagem Direta Gratuita)
FAX : +55 11 534. 8988

PROFESSIONAL AMERICAS

SUPERSCOPE TECHNOLOGIES, INC.
MARANTZ PROFESSIONAL PRODUCTS
2640 WHITE OAK CIRCLE, SUITE A
AURORA, ILLINOIS 60504 USA
PHONE : 630 - 820 - 4800
FAX : 630 - 820 - 8103

PROFESSIONAL AUSTRALIA

TECHNICAL AUDIO GROUP PTY, LTD
558 DARLING STREET,
BALMAIN, NSW 2041,
AUSTRALIA
PHONE : 61 - 2 - 9810 - 5300
FAX : 61 - 2 - 9810 - 5355

CANADA

LENBROOK INDUSTRIES LIMITED
633 GRANITE COURT,
PICKERING, ONTARIO L1W 3K1
CANADA
PHONE : 905 - 831 - 6333
FAX : 905 - 831 - 6936

AUSTRALIA

QualIFI Pty Ltd,
24 LIONEL ROAD,
MT. WAVERLEY VIC 3149
AUSTRALIA
PHONE : +61 - (0)3 - 9543 - 1522
FAX : +61 - (0)3 - 9543 - 3677

THAILAND

MRZ STANDARD CO.,LTD
746 - 754 MAHACHAI ROAD.,
WANGBURAPAPIROM, PHRANAKORN,
BANGKOK, 10200 THAILAND
PHONE : +66 - 2 - 222 9181
FAX : +66 - 2 - 224 6795

SINGAPORE

WO KEE HONG DISTRIBUTION PTE LTD
130 JOO SENG ROAD
#03-02 OLIVINE BUILDING
SINGAPORE 368357
PHONE : +65 858 5535 / +65 381 8621
FAX : +65 858 6078

NEW ZEALAND

WILDASH AUDIO SYSTEMS NZ
14 MALVERN ROAD MT ALBERT
AUCKLAND NEW ZEALAND
PHONE : +64 - 9 - 8451958
FAX : +64 - 9 - 8463554

TAIWAN

PAI- YUING CO., LTD.
6 TH FL NO, 148 SUNG KIANG ROAD,
TAIPEI, 10429, TAIWAN R.O.C.
PHONE : +886 - 2 - 25221304
FAX : +886 - 2 - 25630415

MALAYSIA

WO KEE HONG ELECTRONICS SDN. BHD.
SUITE 8.1, LEVEL 8, MENARA GENESIS,
NO. 33, JALAN SULTAN ISMAIL,
50250 KUALA LUMPUR, MALAYSIA
PHONE : +60 3 - 2457677
FAX : +60 3 - 2458180

JAPAN *Technical*

MARANTZ JAPAN, INC.
35- 1, 7- CHOME, SAGAMIONO
SAGAMIHARA - SHI, KANAGAWA
JAPAN 228-8505
PHONE : +81 42 748 1013
FAX : +81 42 741 9190

日本マランツ株式会社

本社 〒228-8505
神奈川県相模原市相模大野7-35-1
営業本部 〒150-0022
東京都渋谷区恵比寿南1-11-9

KOREA

MK ENTERPRISES LTD.
ROOM 604/605, ELECTRO-OFFICETEL, 16-58,
3GA, HANGANG-RO, YONGSAN-KU, SEOUL
KOREA
PHONE : +822 - 3232 - 155
FAX : +822 - 3232 - 154

SHOCK, FIRE HAZARD SERVICE TEST :

CAUTION : After servicing this appliance and prior to returning to customer, measure the resistance between either primary AC cord connector pins (with unit NOT connected to AC mains and its Power switch ON), and the face or Front Panel of product and controls and chassis bottom.

Any resistance measurement less than 1 Megohms should cause unit to be repaired or corrected before AC power is applied, and verified before it is return to the user/customer.

Ref. UL Standard No. 1492.

In case of difficulties, do not hesitate to contact the Technical Department at above mentioned address.

1.1 TECHNICAL SPECIFICATIONS

General

System	DVD system and Compact Disc digital audio system
Power requirements	
F Version (Japan)	AC 100 V, 15W
N Version (Europe)	AC 230 V, 15W
K Version (China)	AC 220 V, 16W
S Version (HK, S'pore, etc.)	AC 230 V, 16W
L Version (Taiwan)	AC 110 V, 15W
C Version (Korea)	AC 220 V, 16W
U Version (USA)	AC 120 V, 15W
A Version (Australia)	AC 240 V, 17W
Weight	
DV-17	6 kg
DV-18mkII	5.8 kg
DV7010	3.9 kg
Dimensions	
DV-17/DV-18mkII	458 (W) x 313 (D) x 88 (H) mm
DV7010	440 (W) x 304 (D) x 87 (H) mm
	(Not including protruding cables, etc.)
Operating temperature	+5°C to +35°C (+36°F to 96°F)
Operating humidity	5% to 85% (no condensation)

S-Video output

Y (luminance) - Output level	1 Vp-p (75)
C (color) - Output level	286 mVp-p (75) (NTSC)
	300 mVp-p (75) (P AL)
Jacks	S-VIDEO jack

Video output

Output level	1 Vp-p (75)
Jacks	RCA jacks

Component video output

(Y, C _B , C _R)	
Output level	Y: 1.0 Vp-p (75)
	CB, CR: 0.7 Vp-p (75)
Jacks	RCA jacks (F, K, S, L, C, U, A)
R/G/B output	
Output level	R/G/B: 0.7Vp-p (75)
Jacks	21pin SCART connector (N)

Audio output

Output level	
During audio output	200 mVrms (1 kHz, -20 dB)
Number of channels	2
Jacks	RCA jacks

Digital audio characteristics

Frequency response	4 Hz to 44kHz (DVD fs: 96 kHz)
S/N ratio	More than 115dB
Dynamic range	More than 102dB
Total harmonic distortion	0.002%
Wow and flutter	Limit of measurement
	(±0.001% W. PEAK) or lower

Digital output

Optical digital output	Optical digital jack
Coaxial digital output	RCA jack

Accessories

Remote control unit	1
Dry cell batteries	
DV-18mkII/DV7010: AA (R6P)	2
DV-17: AAA (RO3P)	2
Audio/Video Cable	1
Remote Control Cable	1
Operating Instructions	1

• The specifications and design of this product are subject to change without notice, due to improment.

1.2 CONNECTION FACILITIES

1.2.1 Video performance (N only)

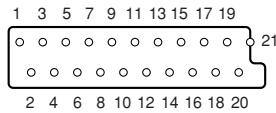

1.2.1.1 SCART

Pin No. TV (OUT)

Pin 1	Audio R out : 2Vrms
Pin 2	Audio R in : 2Vrms
Pin 3	Audio L out : 2Vrms
Pin 4	GND
Pin 5	GND
Pin 6	Audio L in : 2Vrms
Pin 7	Blue out/C in Blue : 0.7Vpp ±0.1V into 75 Ohm *1 C : 300mVpp ±30 into 75 Ohm *2
Pin 8	function switching out <2V : TV >5/<8 : asp.ratio 16 : 9 DVD/AUX >9.5/<12 : asp.ratio 4 : 3 DVD/AUX
Pin 9	GND
Pin 10	not connected
Pin 11	Green out:0.7Vpp ±0.1V into 75 Ohm *1
Pin 12	not connected
Pin 13	GND
Pin 14	GND
Pin 15	Red/C out Red : 0.7Vpp ±0.1V into 75 Ohm *1 C : 300mVpp ±30 into 75 Ohm *2
Pin 16	fast switching out <0.4V into 75 Ohm=CVBS/S-Video 1</<3 into 75 Ohm=RGB
Pin 17	GND
Pin 18	GND
Pin 19	CVBS/Y out : 1Vpp ±0.1V *1
Pin 20	CVBS/Y in : 1Vpp ±0.1V *1
Pin 21	GND

Pin No. AUX (IN)

Pin 1	Audio R out : 2Vrms
Pin 2	Audio R in : 2Vrms
Pin 3	Audio L out : 2Vrms
Pin 4	GND
Pin 5	GND
Pin 6	Audio L in : 2Vrms
Pin 7	Blue in/C out Blue : 0.7Vpp ±0.1V into 75 Ohm *1 C : 300mVpp ±30 into 75 Ohm *2
Pin 8	function switching in<2V : DVD >5/<8 : asp.ratio 16 : 9 AUX >9.5/<12 : asp.ratio 4 : 3 AUX
Pin 9	GND
Pin 10	not connected
Pin 11	Green in:0.7Vpp ±0.1V into 75 Ohm
Pin 12	not connected
Pin 13	GND
Pin 14	GND
Pin 15	Red/C in Red : 0.7Vpp ±0.1V into 75 Ohm *1 C : 300mVpp ±30 into 75 Ohm *2
Pin 16	fast switching in <0.4V into 75 Ohm=CVBS/S-Video 1</<3 into 75 Ohm=RGB
Pin 17	GND
Pin 18	GND
Pin 19	CVBS/Y out : 1Vpp ±0.1V *1
Pin 20	CVBS/Y in : 1Vpp ±0.1V *1
Pin 21	GND

*1 : 100% White *2 : Burst Level *3 : color bar(chroma level : 75%)

What are "regional codes"?

Motion picture studios want to control the home release of movies in different countries because theater releases aren't simultaneous (a movie may come out on DVD in the US when it's just hitting screens in Europe). Therefore they have required that the DVD standard include codes which can be used to lock out the playback of certain discs in certain geographical regions. Players sold in each region will have that region's code built into the player. The player will refuse to play these "region coded" discs which are not allowed in the region. However, regional codes are entirely optional. Discs without codes will play on any player in any country. Some studios have already announced that only their new releases will have regional codes. There are six regions:

1. United States and Canada
2. Europe and Japan
3. Far East (except Japan & China)
4. South America and Oceania
5. Africa and the Middle East
6. China (except Hong Kong)

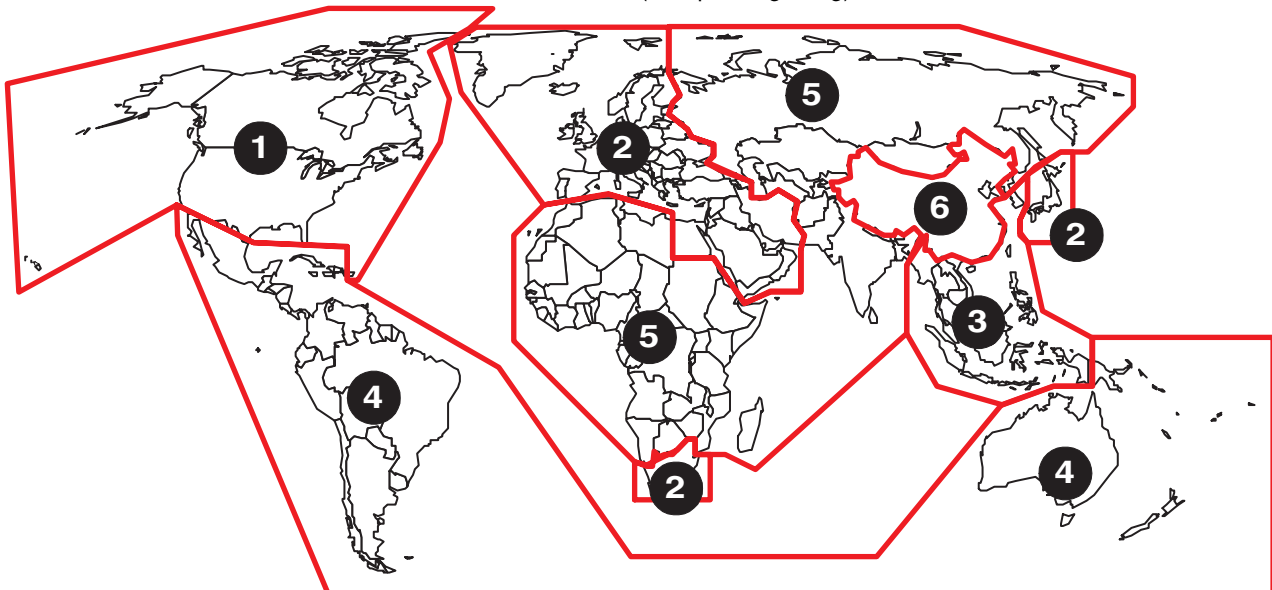

Map of DVD Regions

1.3 INFORMATIONS

REGION CODE

VERSION	REGION CODE	COUNTRY
/UXX	1	USA/CANADA
/FXX	2	JAPAN
/NXX	2	EUROPE
/CXX	3	KOREA
/LXX	3	TAIWAN
/SXX	3	SINGAPORE/HONGKONG
/AXX	4	AUSTRALIA
/KXX	6	CHINA

DVD INFORMATION

Below is a glossary of the new terms related to DVD.

Title:

A disc may have more than one story/movie on it, so each story/movie is called a "title".

For example, if there are 2 movies on the disc, they are separated into Title 1 and Title 2.

Chapter:

A title may also be separated into chapters.

For example, a movie (title) may be separated into 3 scenes (chapters).

Title 1			Title 2		
Chapter 1	Chapter 2	Chapter 3	Chapter 1	Chapter 2	Chapter 3

Subtitles:

DVDs are recorded with up to 32 different subtitle languages. If a disc has more than one subtitle language, you can select the subtitle language that you want to read.

Soundtrack language:

DVDs are recorded with up to 8 different soundtrack languages. If a disc has more than one language, you can select the soundtrack language that you want to listen to.

Multi-angles:

On some DVDs, scenes have been filmed from different angles (up to a maximum of 9). On these discs, you can select the angle that you want to watch. Please refer to the DVD's manual to see which scenes have multi-angles.









Resetting the Player to System Settings:

To reset the player, press and hold [STOP] button on the front panel when pressing Power switch to turn the power on.

All program memory, saved settings from functions such as Last Memory and Condition Memory are cleared, and all Setup screen menus are returned to factory settings.

THE DISCS THAT THE DV7010/DV-18mkII/DV-17 CAN HANDLE

The following discs can be played back with a DV7010/DV-18mkII/DV-17.

Types of playable discs and their marks	Diameter/ Playable sides	Playback time
	12 cm (5 in.)/ single-sided	1 layer 2 layer 133 min. 242 min.
	12 cm (5 in.)/ double-sided	1 layer 2 layer 266 min. 484 min.
	8 cm (3 in.)/ single-sided	1 layer 2 layer 41 min. 75 min.
	8 cm (3 in.)/ double-sided	1 layer 2 layer 82 min. 150 min.
	S VIDEO CD 12 cm (5 in.)/ single-sided	Digital audio (MPEG 1) Digital video (MPEG 2) 40 min.
	S VIDEO CD single 8 cm (3 in.)/ single-sided	Digital audio (MPEG 1) Digital video (MPEG 2) 10 min.
	VIDEO CD 12 cm (5 in.)/ single-sided	Digital audio Digital video (MPEG 1) Max. 74 minutes
	VIDEO CD single 8 cm (3 in.)/ single-sided	Digital audio Digital video (MPEG 1) Max. 20 minutes
	CD 12 cm (5 in.)/ single-sided	 Digital audio Max. 74 minutes
	CD single 8 cm (3 in.)/ single-sided	 Digital audio Max. 20 minutes
	F-Disc 	(F only) (株) フジカラーサービスの フジテレシネサービスで作成された ディスクです。

Note: The regional code of the discs must meet to the regional code of the DV7010/DV-18mkII/DV-17.

1.4 SERVICING HINT

SERVICE HINTS

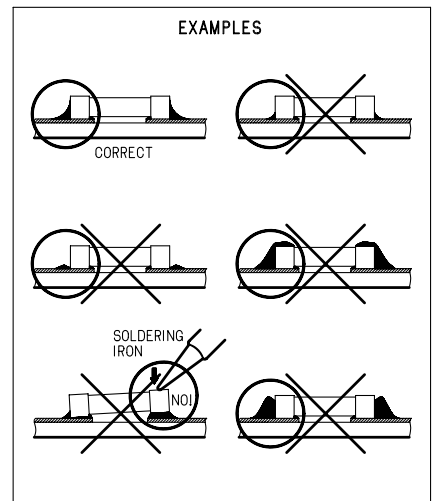
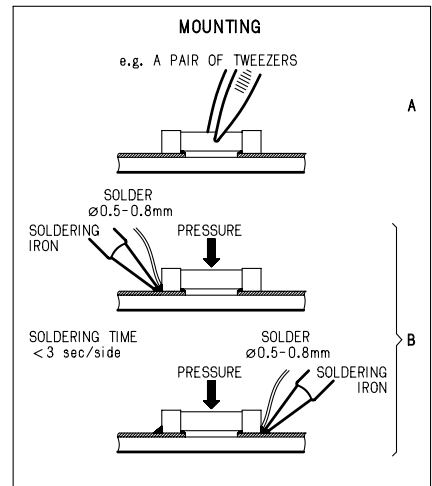
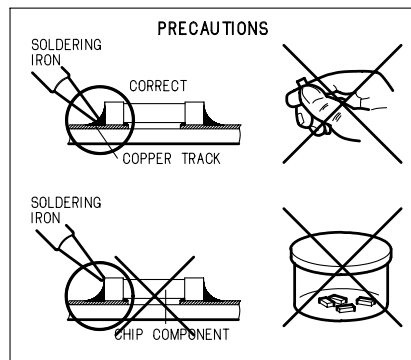
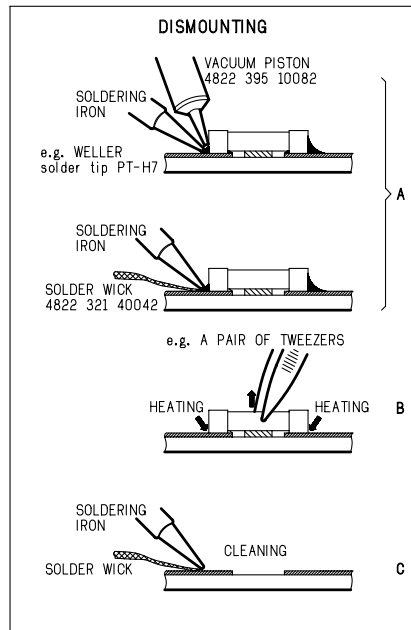
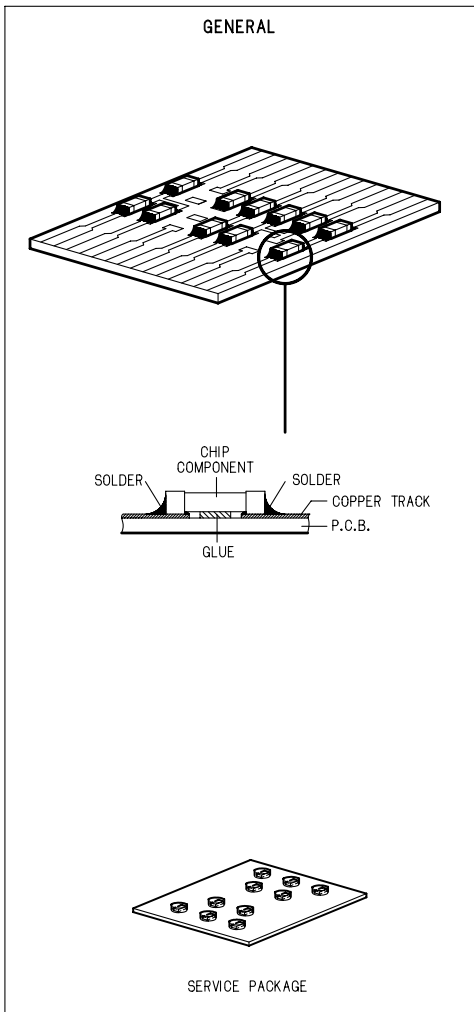

SERVICE TOOLS

Audio signals disc	4822 397 30184
Disc without errors (SBC444)+	
Disc with DO errors, black spots and fingerprints (SBC444A)	4822 397 30245
Disc (65 min 1kHz) without no pause	4822 397 30155
Max. diameter disc (58.0 mm)	4822 397 60141
Torx screwdrivers	
Set (straight)	4822 395 50145
Set (square)	4822 395 50132
13th order filter	4822 395 30204
DVD test disc (PAL)	4822 397 10131
DVD test disc (NTSC) ALMEDIO	TDV-540

1.5 DISASSEMBLY

Taking the disc out for EMERGENCY (For example: when it is not possible to turn on the product. The disc cannot be taken out from the loader.)

1. Remove the top cover (001D).
2. Remove the A screw from the bridge on the loader base. (see fig. 1)
3. Remove the B screw from the chassis <DV-17/DV-18mkII only>. (see fig. 1)
4. Remove the two C hooks of the bridge from the loader base. (see fig. 1)

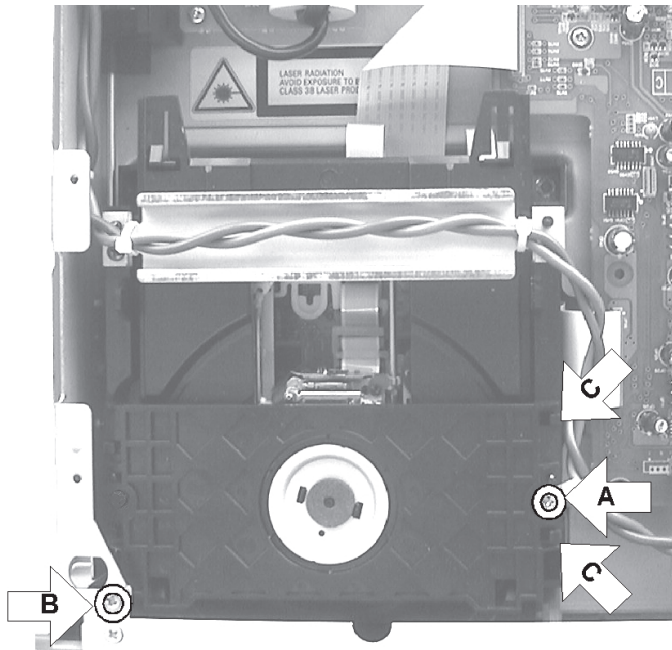

DV-17/DV-18mkII

1.5 DISASSEMBLY

電源が入らない時のディスクの取り出し方

1. トップカバーを外す。
2. クランパープレート上面の矢印Aピスを取り外す。(fig. 1 参照)
3. (DV-17/DV-18mkII の場合のみ) シャーシの矢印B ピスを取り外す。(fig. 1 参照)
4. クランパープレートを固定している矢印C フックを外す。(fig. 1 参照)

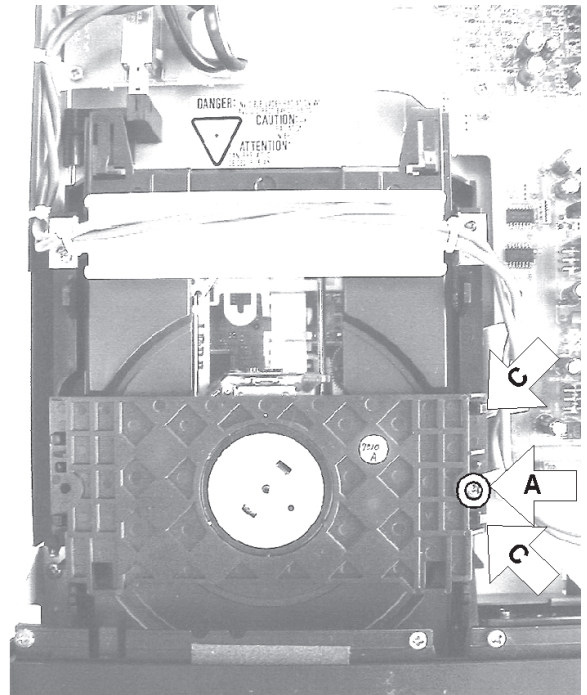

DV7010

Fig. 1

5. Remove the bridge with clasper (see fig. 2). Then, it is possible to take the disc out from the loader.

5. クランパープレートを少し持ち上げ、反対側のフックを外し、クランパープレートを取り外してディスクを取り出す。(fig. 2 参照)

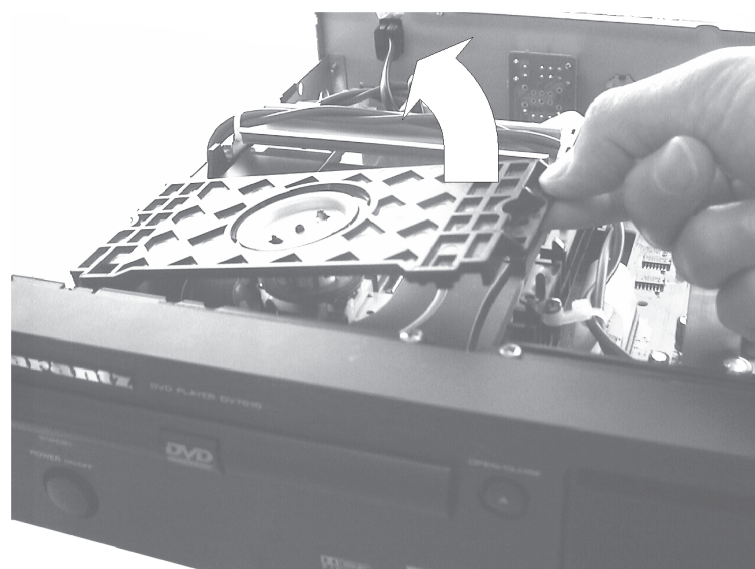

Fig. 2

Removal of the DVD module for DV-17/DV-18mkII

1. Remove the top cover (001D).
2. Disconnect the two flat cables (WV01 and WP02) from the connectors on the main PCB. (see fig. 3)
3. Remove the A screw from the bridge on the loader base. (see fig. 3)
4. Cut and remove the two D cable ties from the cables and chassis. (see fig. 3)
5. Remove the B screw from the chassis. (see fig. 3)
6. Remove the four E screws. (see fig. 3)
7. Remove the DVD module from the chassis, while sliding it in the direction of the rear panel.

Removal of the DVD module for DV7010

1. Remove the top cover (001D).
2. Turn on the product and press the OPEN/CLOSE button. Then the tray is opened. (If the product shuts down the power completely, see below "REMARK".)
REMARK : Insert a screwdriver (minus) into the hole at the left side of chassis. (see fig. 4)
Turn the gear with the screwdriver. (see fig. 5)
Then the tray is moved a little. Pull the tray with your hand at this time.
3. Remove the escutcheon on the tray.
4. Press the OPEN/CLOSE. (or Push the tray with your hand.) Then the tray is closed.
5. Disconnect the two flat cables (WV01 and WP02) from the connectors on the main PCB. (see fig. 3)
6. Remove the A screw from the bridge on the loader base. (see fig. 3)
7. Cut and remove the two D cable ties from the cables and chassis. (see fig. 3)
8. Remove the DVD module from the chassis, while sliding it in the direction of the rear panel.

DVD モジュールの取り外し方 (DV-17/DV-18mkII)

1. トップカバーを外す。
2. フラットケーブル WV01 と WP02 をメイン基板のコネクターから外す。(fig. 3 参照)
3. クランププレート上面の矢印Aビスを取り外す。(fig. 3 参照)
4. 矢印D のケーブルタイ 2 箇所を外す。(fig. 3 参照)
5. シャーシの矢印B ビスを取り外す。(fig. 3 参照)
6. 矢印E ビス 4 本を取り外し、DVD モジュールをセット後方にずらしながら、取り出す。(fig. 3 参照)

DVD モジュールの取り外し方 (DV7010)

1. トップカバーを外す。
2. 電源を入れて OPEN/CLOSE ボタンを押し、トレイを出す。
注意 : 電源が入らない場合は、シャーシ左側面の穴 (fig. 4 参照) よりマイナスドライバー等を挿入し、矢印の方向にギアを回しながらトレイを少し引き出す。(fig. 5 参照)あとは手でトレイを引き出す。
3. トレーについているエスカッションを取り外す。
4. トレーを閉める。
5. フラットケーブル WV01 と WP02 をメイン基板のコネクターから外す。(fig. 3 参照)
6. クランププレート上面の矢印Aビスを取り外す。(fig. 3 参照)
7. 矢印D のケーブルタイ 2 箇所を外す。(fig. 3 参照)
8. 矢印E ビス 4 本を取り外し、DVD モジュールをセット後方にずらしながら、取り出す。(fig. 3 参照)

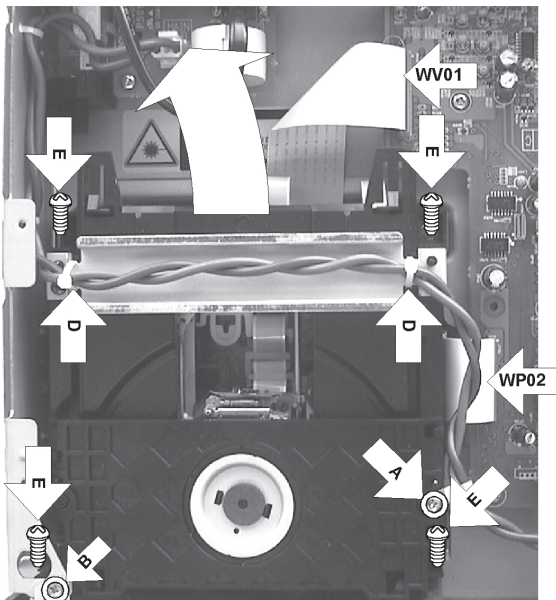

Fig. 3

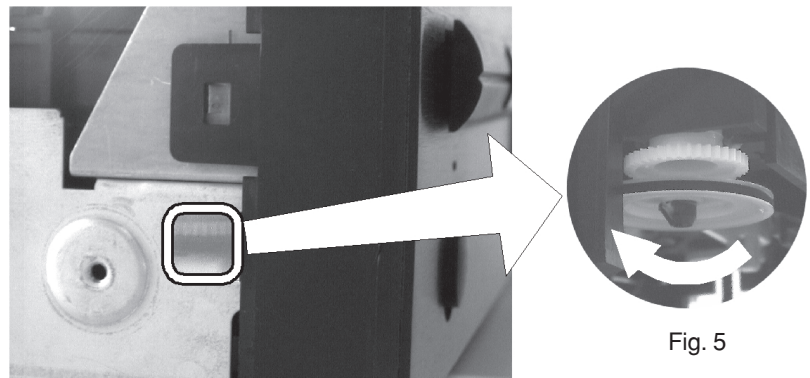
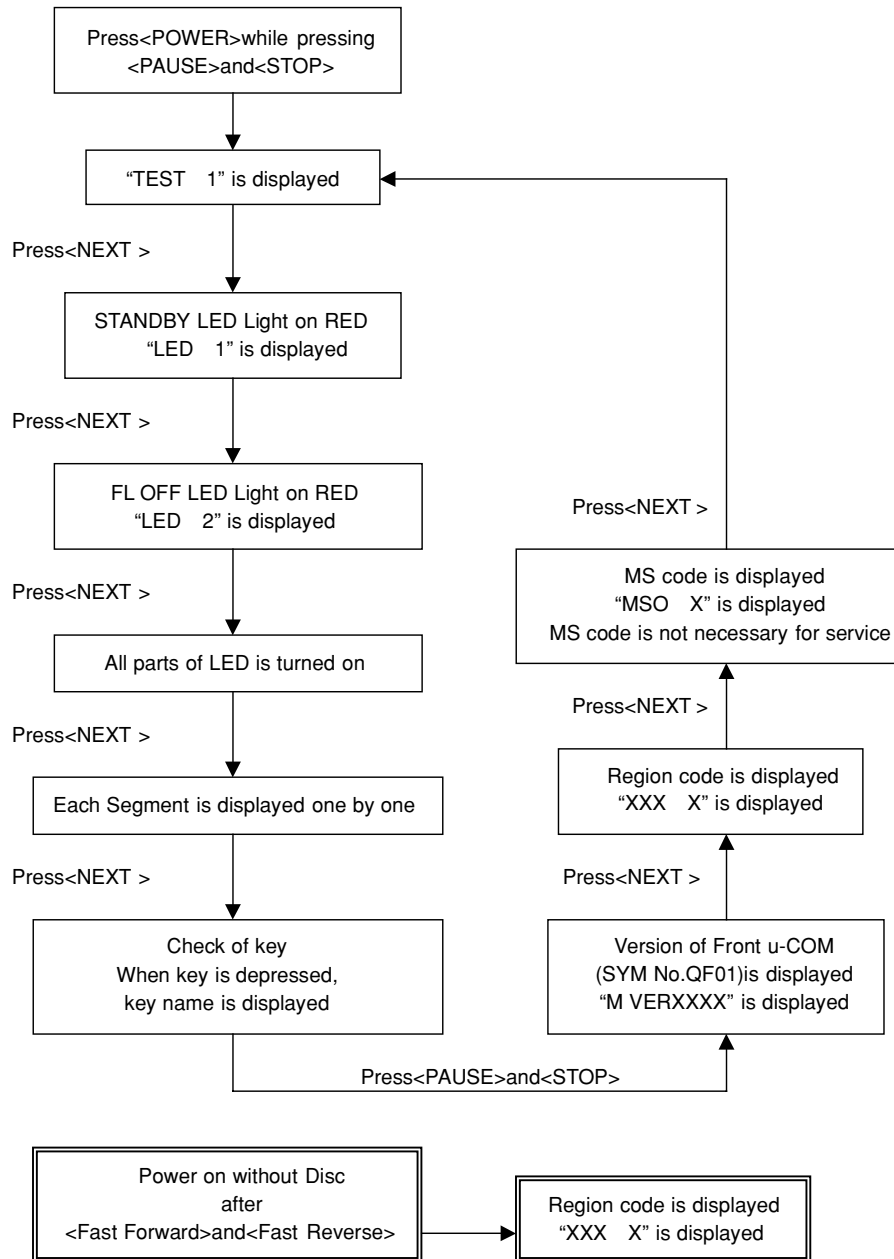

Fig. 4

1.6 SERVICE MODE



ERROR CODE

Error codes are displayed on the FL display.

FL Display	Possible causes	Operation of the unit
AV1 VER	AV-1 chip is not a match with program of system controller.	The sound may not out with the specific audio.
CPU AERR	CPU address error. (Hardware is unusual.)	No operation.
DMA AERR	DMA address error. (Hardware is unusual.)	No operation.
FLASH ID	Difference in versions of the internal ROM of the system controller and of the flash ROM, or bus line failure or reverse installation.	No operation.
FLASH WRP	Write protect error of the flash ROM.	No operation.
FLASH SIG	Difference in part number of the flash ROM. (When the ROM which couldn't be used was used.)	No operation.
FLASH SUM	Check sum error of the flash ROM (It exceeds the regular size.) or reverse installation. (Hardware is unusual.)	No operation.
FLASH SIZE	Size error of the flash ROM. (Use 4 or 8 M-bit.)	No operation.
ILLGAL	The system controller fetched a code other than an operation code. (Hardware is unusual.)	No operation.
RESERVE	Undefined interrupt. (Hardware is unusual.)	No operation.
SLOT	Inappropriate slot command issued. (Hardware is unusual.)	No operation.

1.7 WAVEFORM

Power requirements (Refer the circuit diagram page 1-15 to 1-16)

100V AC

① 100V 10μsec

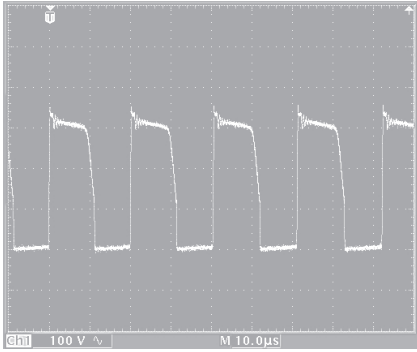

120V AC

① 100V 10μsec

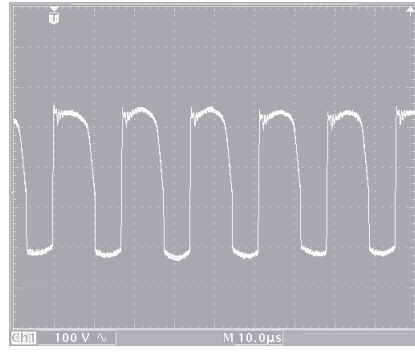

220V AC

① 100V 10μsec

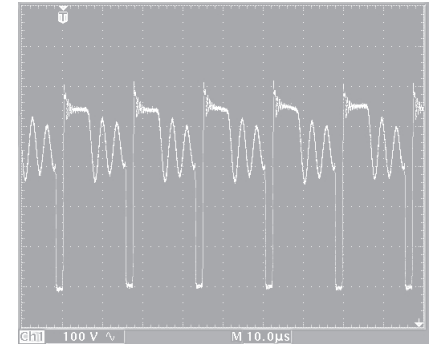

② 10V 10μsec

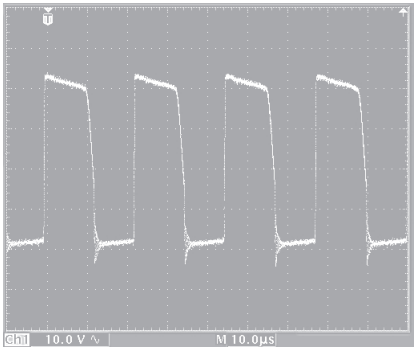

② 10V 10μsec

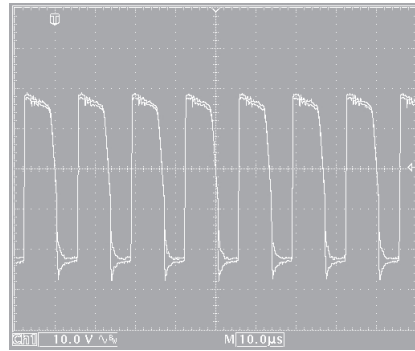

② 20V 10μsec

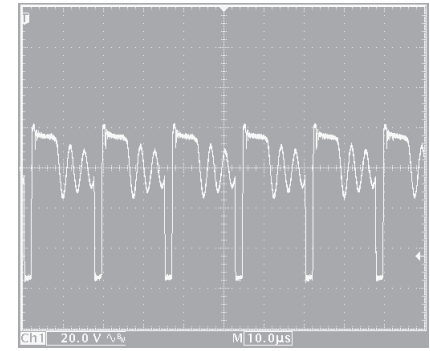

③ 1V 10μsec

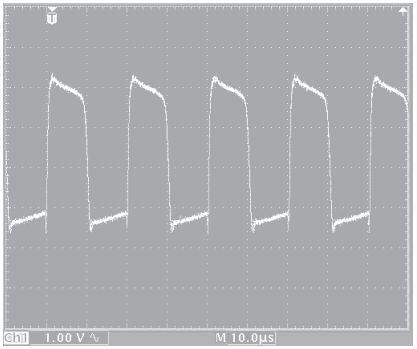

③ 1V 10μsec

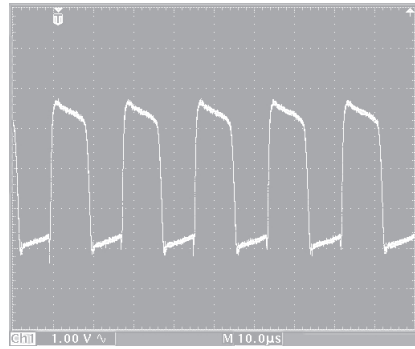

③ 200mV 10μsec

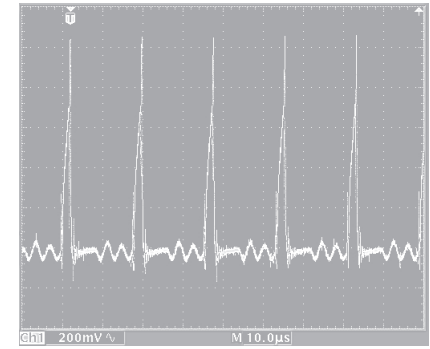

④ 200mV 10μsec



④ 200mV 10μsec



④ 100mV 10μsec

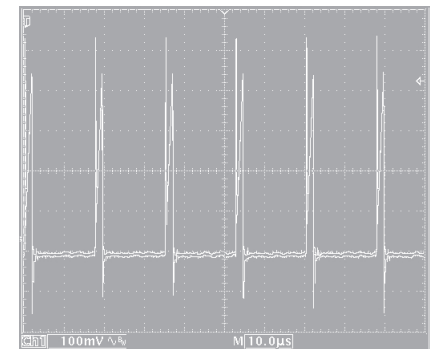

1.8 WIRING DIAGRAM

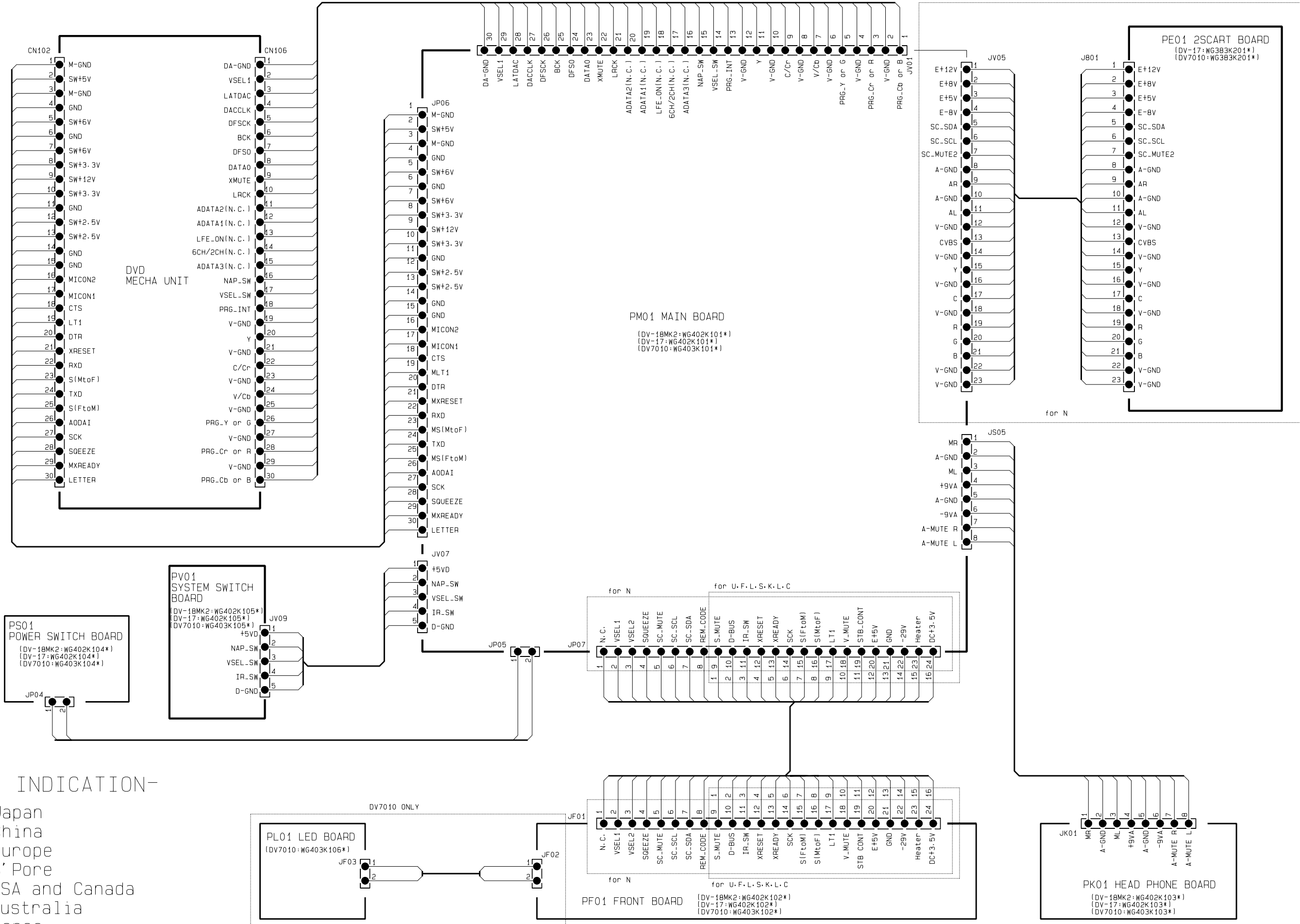

-AREA INDICATION-

- F:Japan
- K:China
- N:Europe
- S:S'Pore
- U:USA and Canada
- A:Australia
- C:Korea
- L:Taiwan

1.9 BLOCK DIAGRAM

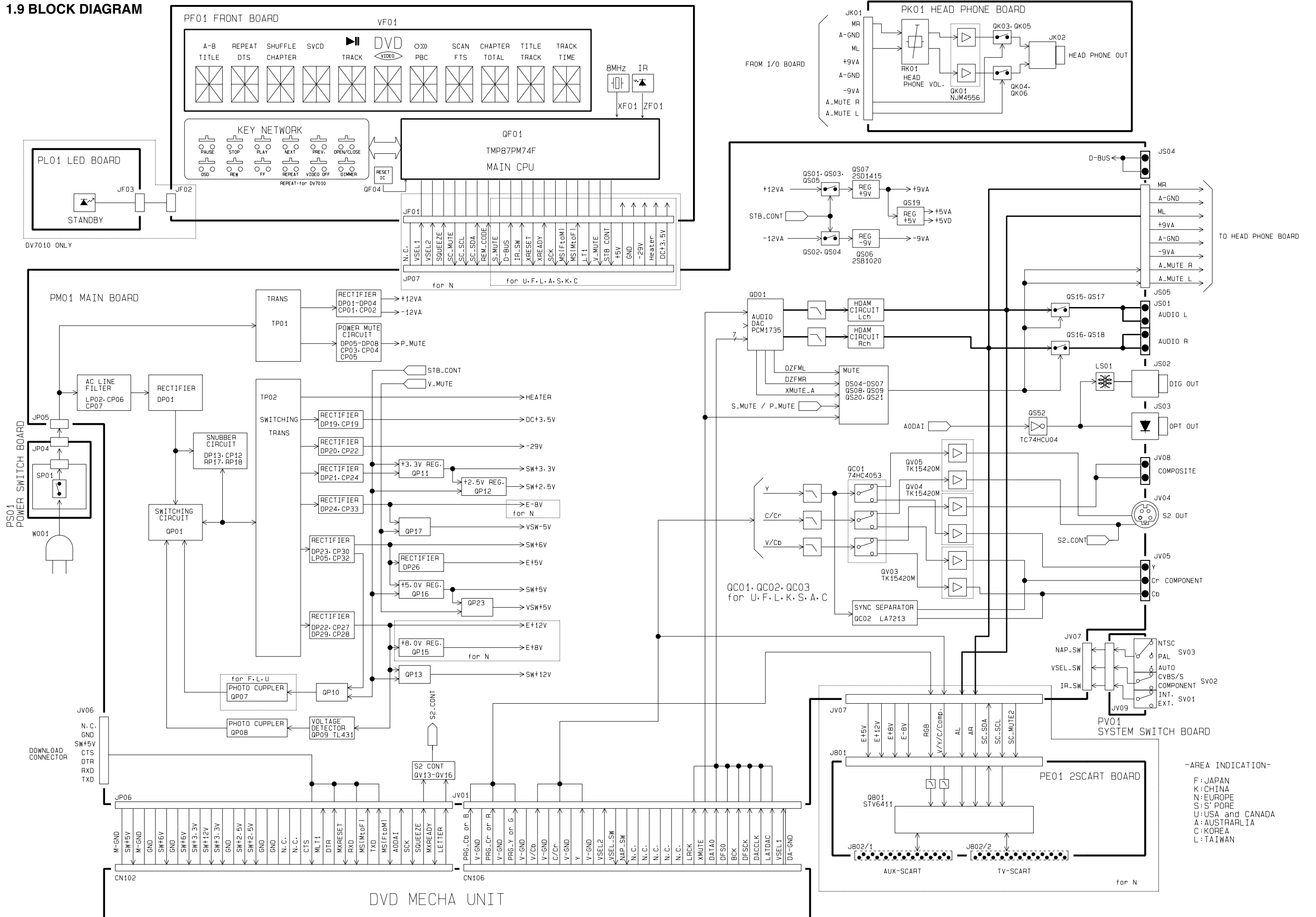

-AREA INDICATION-

- F: JAPAN
- K: CHINA
- N: EUROPE
- S: S' PORE
- U: USA and CANADA
- A: AUSTRALIA
- C: KOREA
- L: TAIWAN

1.10 SCHEMATIC DIAGRAM AND PARTS LOCATION

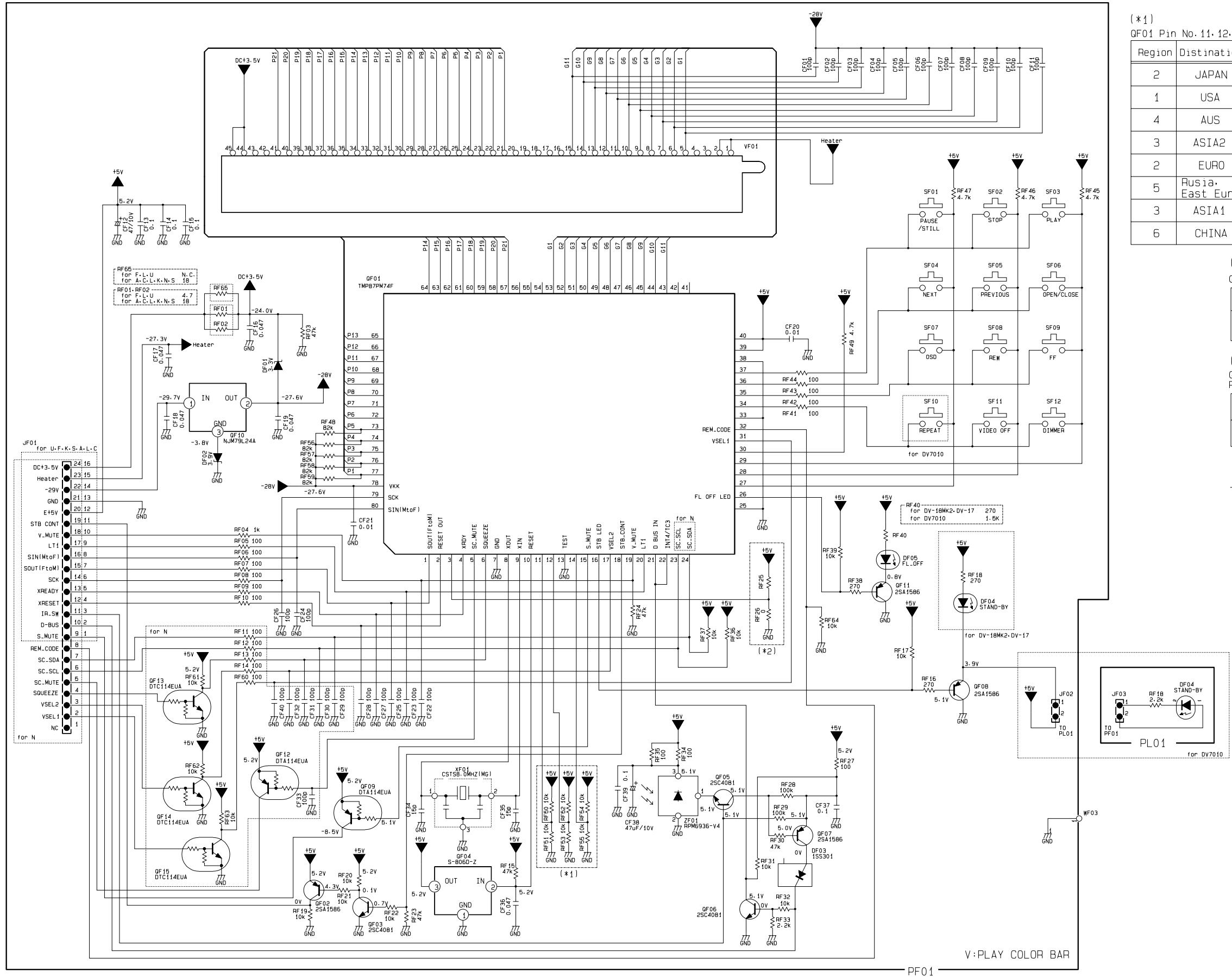

(*1)
QF01 Pin No. 11, 12, 14 SETTING

Region	Distination	Pin No. MS1	11	12	14
2	JAPAN	0	L	L	L
1	USA	1	H	L	L
4	AUS	2	L	H	L
3	ASIA2	2	H	H	L
2	EURO	4	L	L	H
5	Rusia, East Euro	5	H	L	H
3	ASIA1	6	L	H	H
6	CHINA	6	H	H	H

(*2)
QF01 Pin No. 3 SETTING

DV7100	H
DV-18MK2 DV7010 DV-17	L

(*3)
QF01 Pin No. 32
REMOTE CONTROL CODE SETTING

RC6 044	H
RC6 004	L

-AREA INDICATION-

F: Japan
K: China
N: Europe
S: S' Pore
U: USA and Canada
A: Australia
C: Korea
L: Taiwan

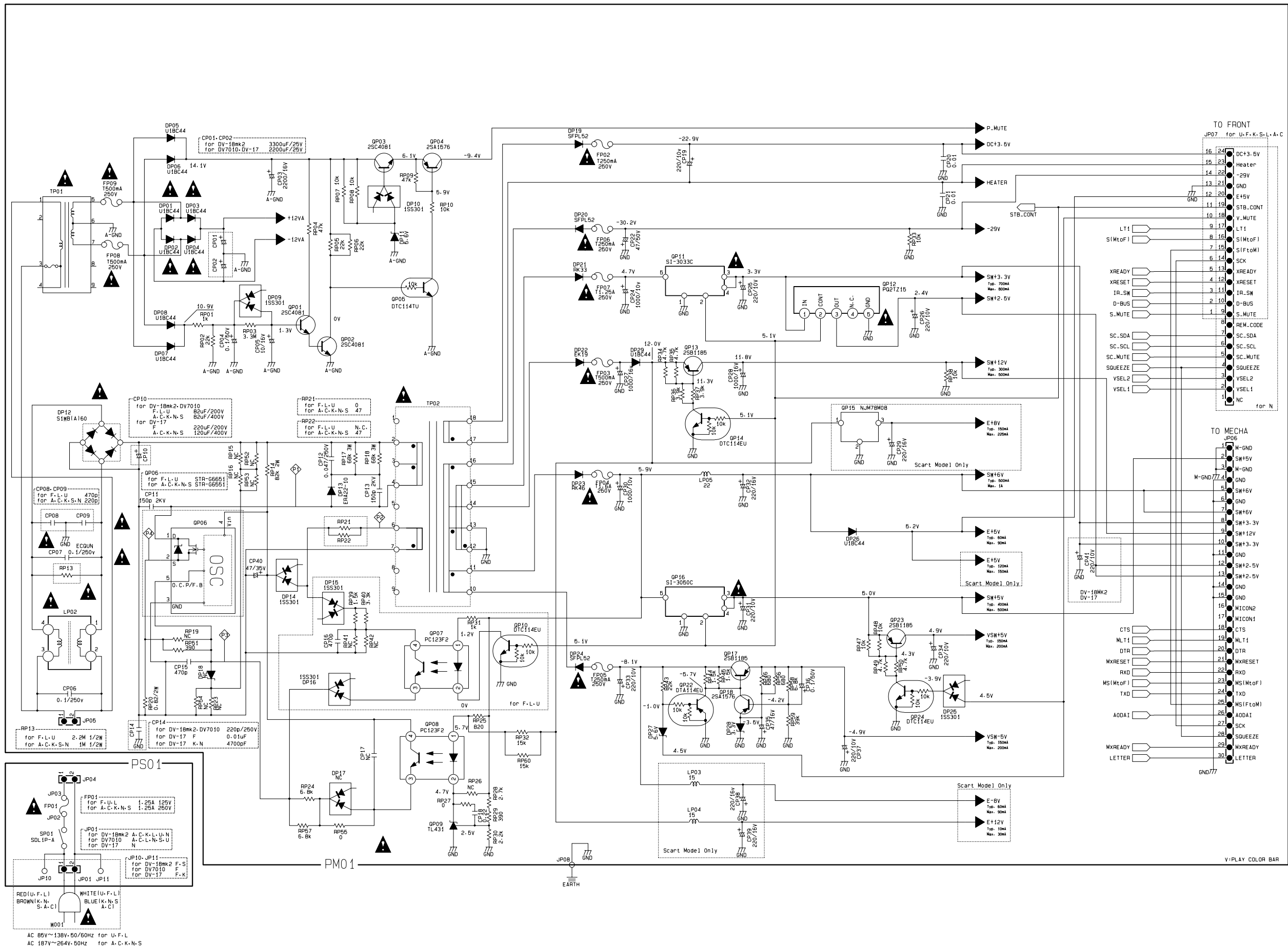

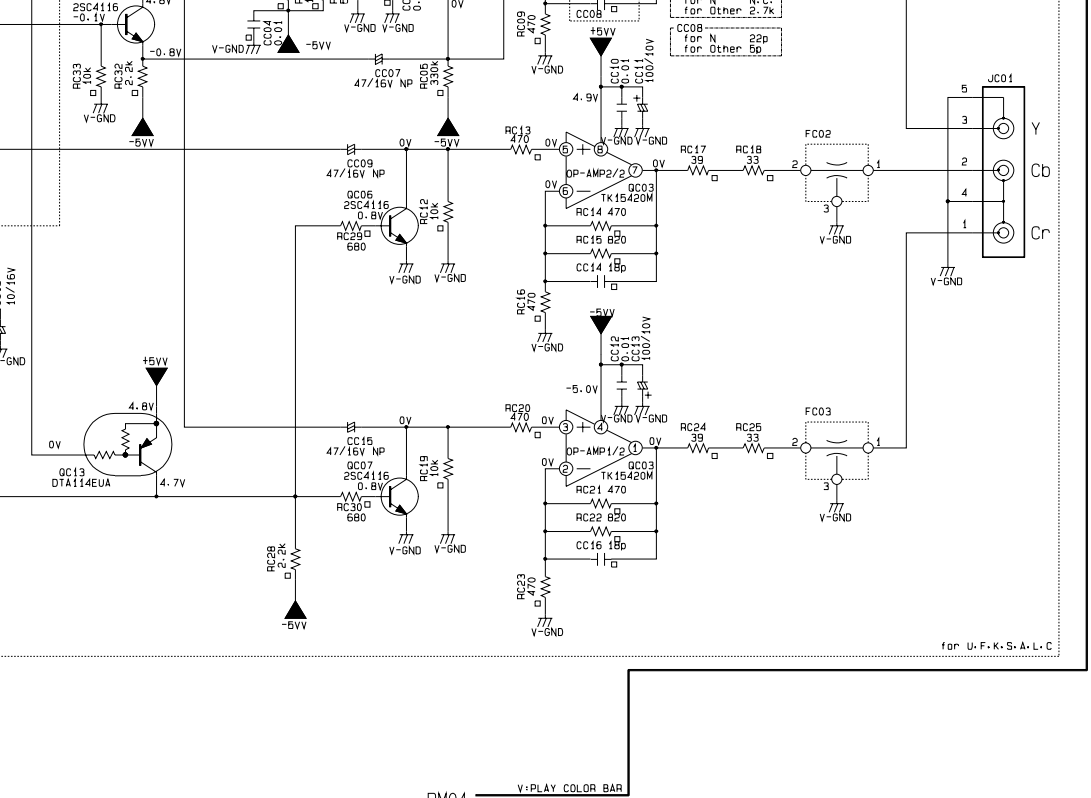
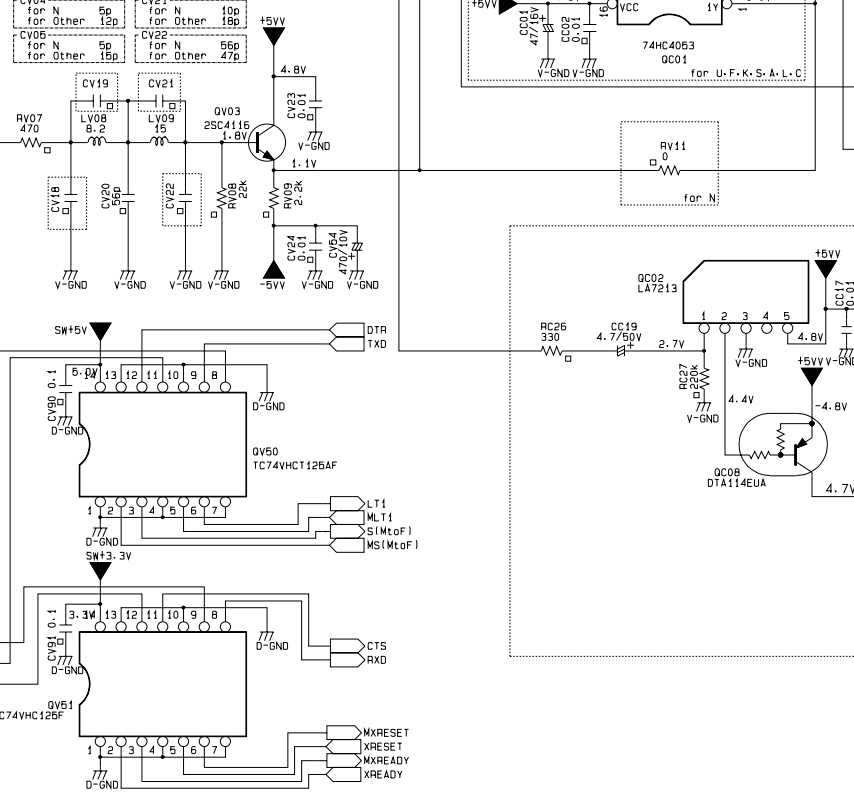
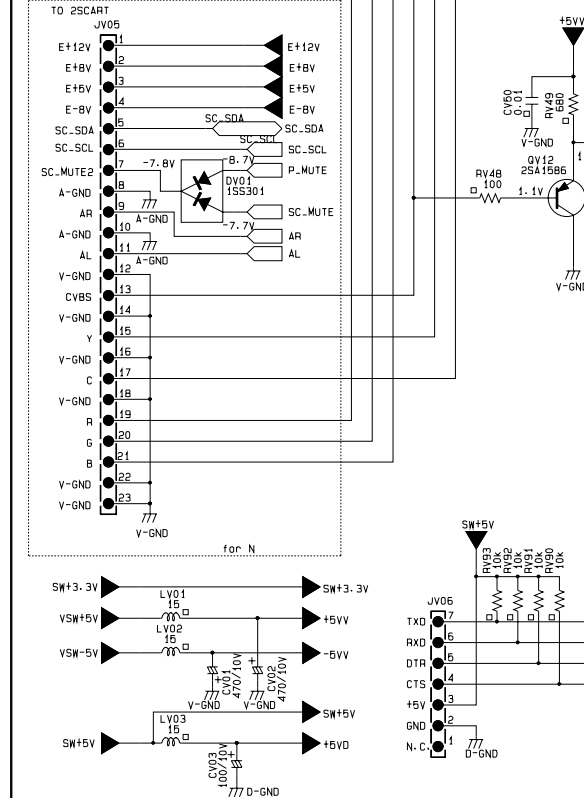
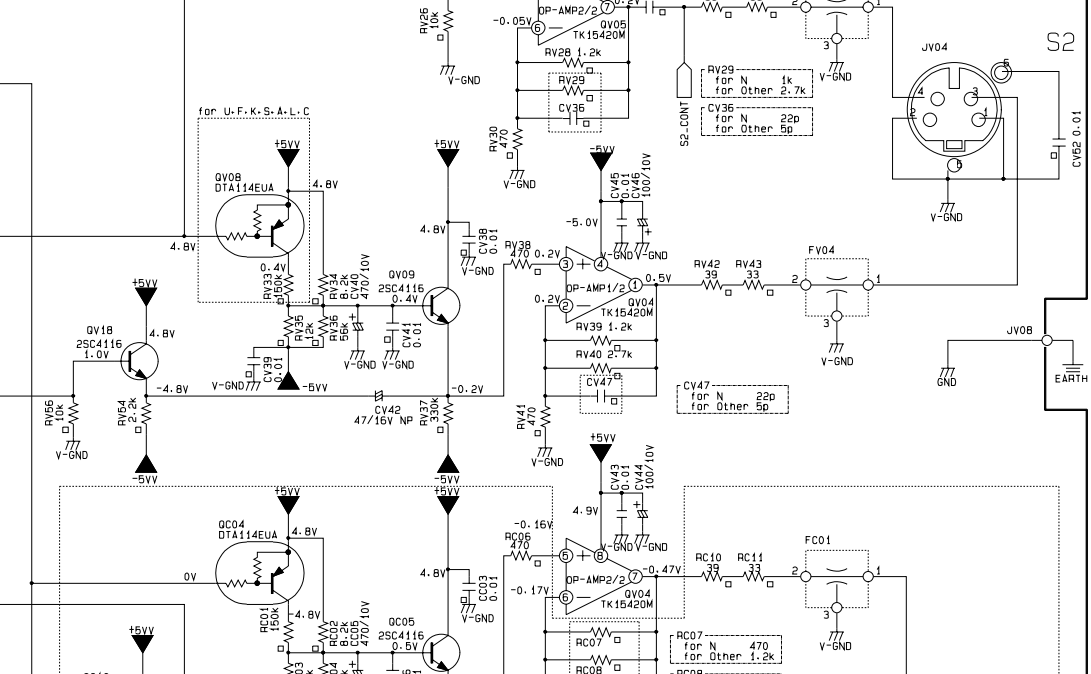
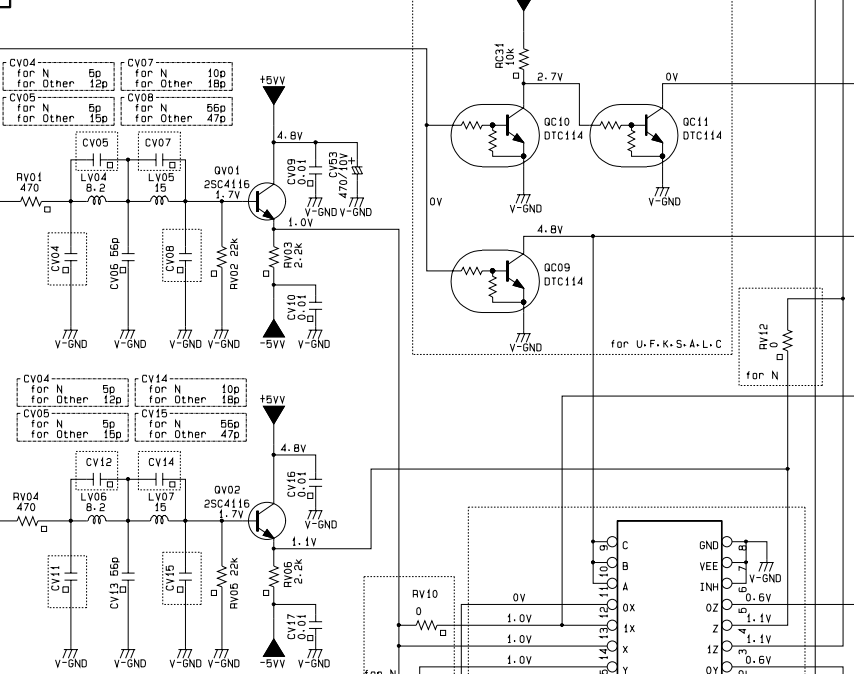
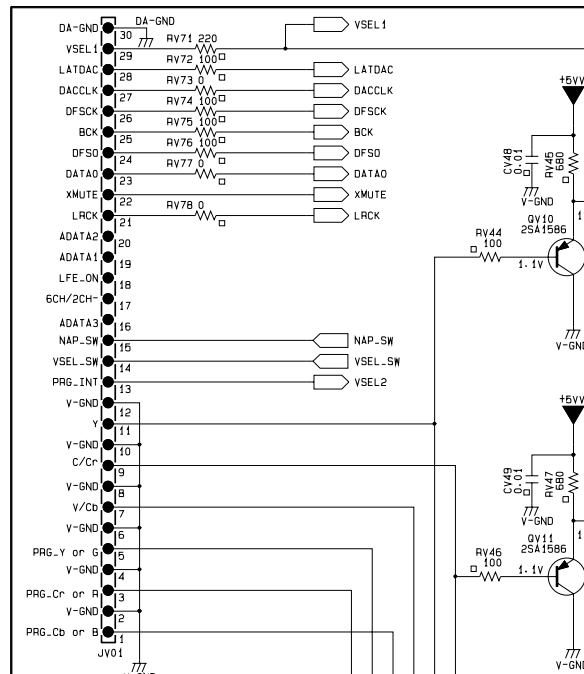
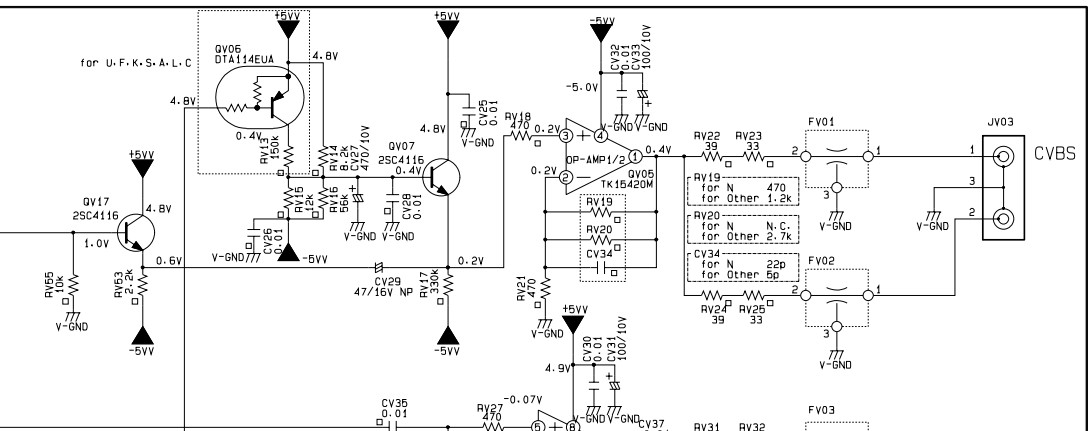
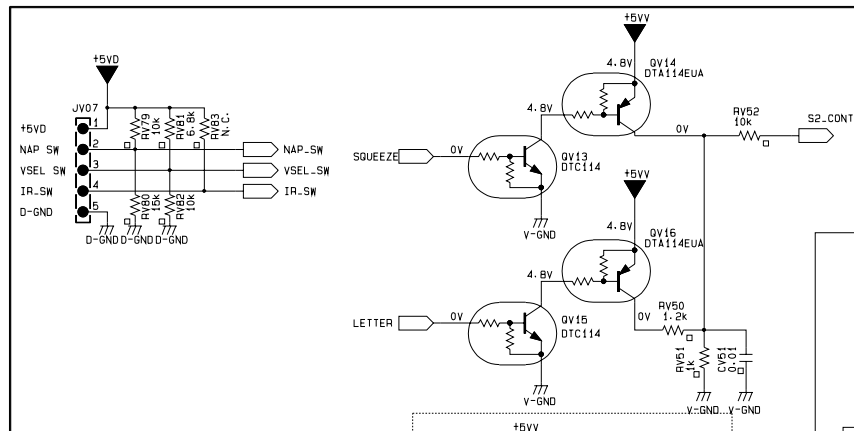
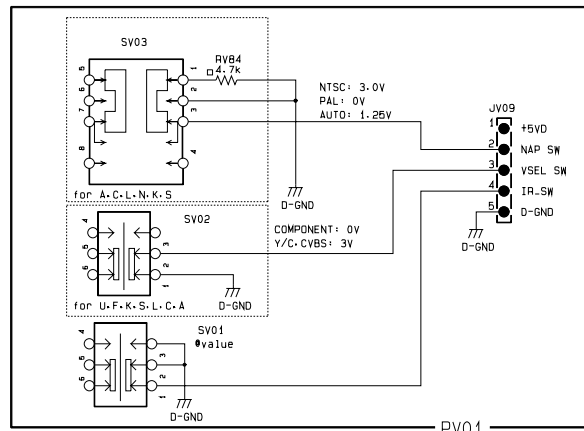

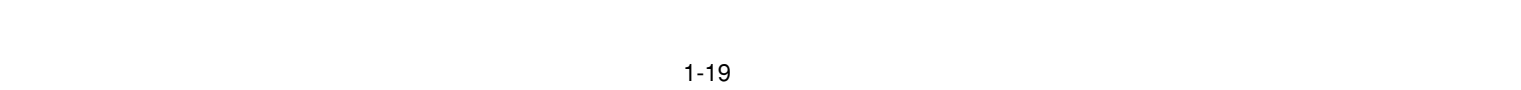
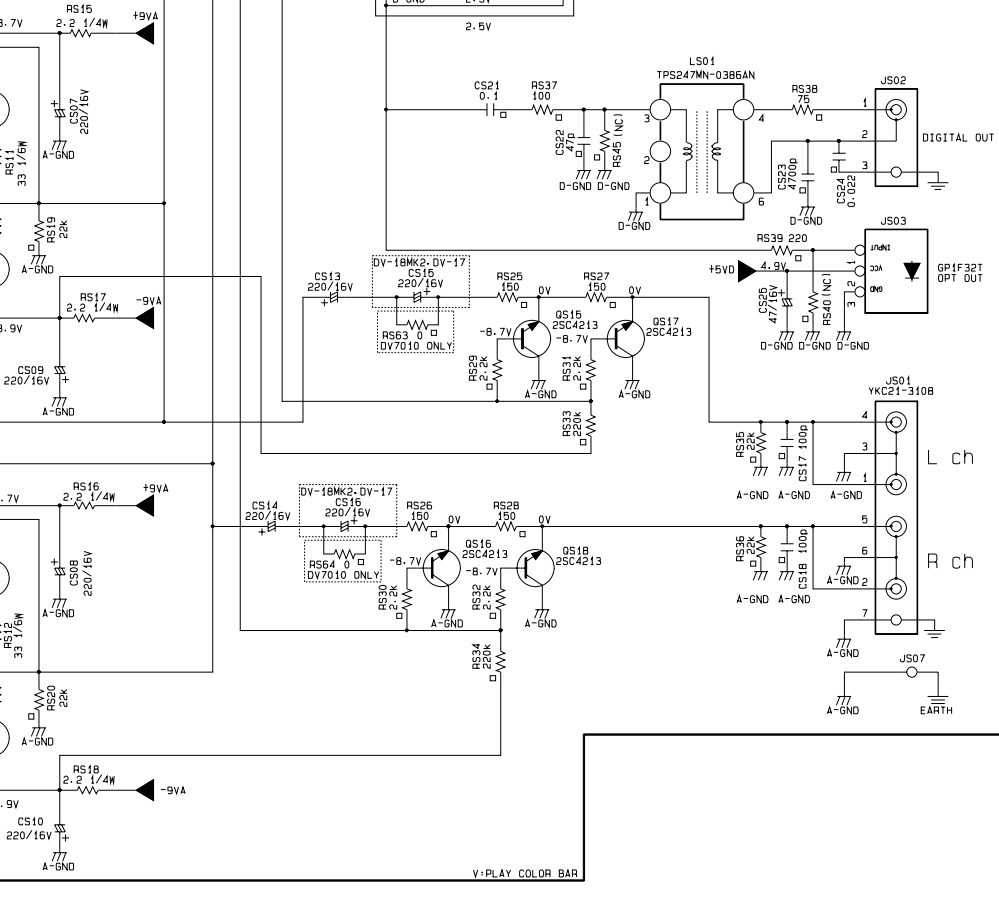
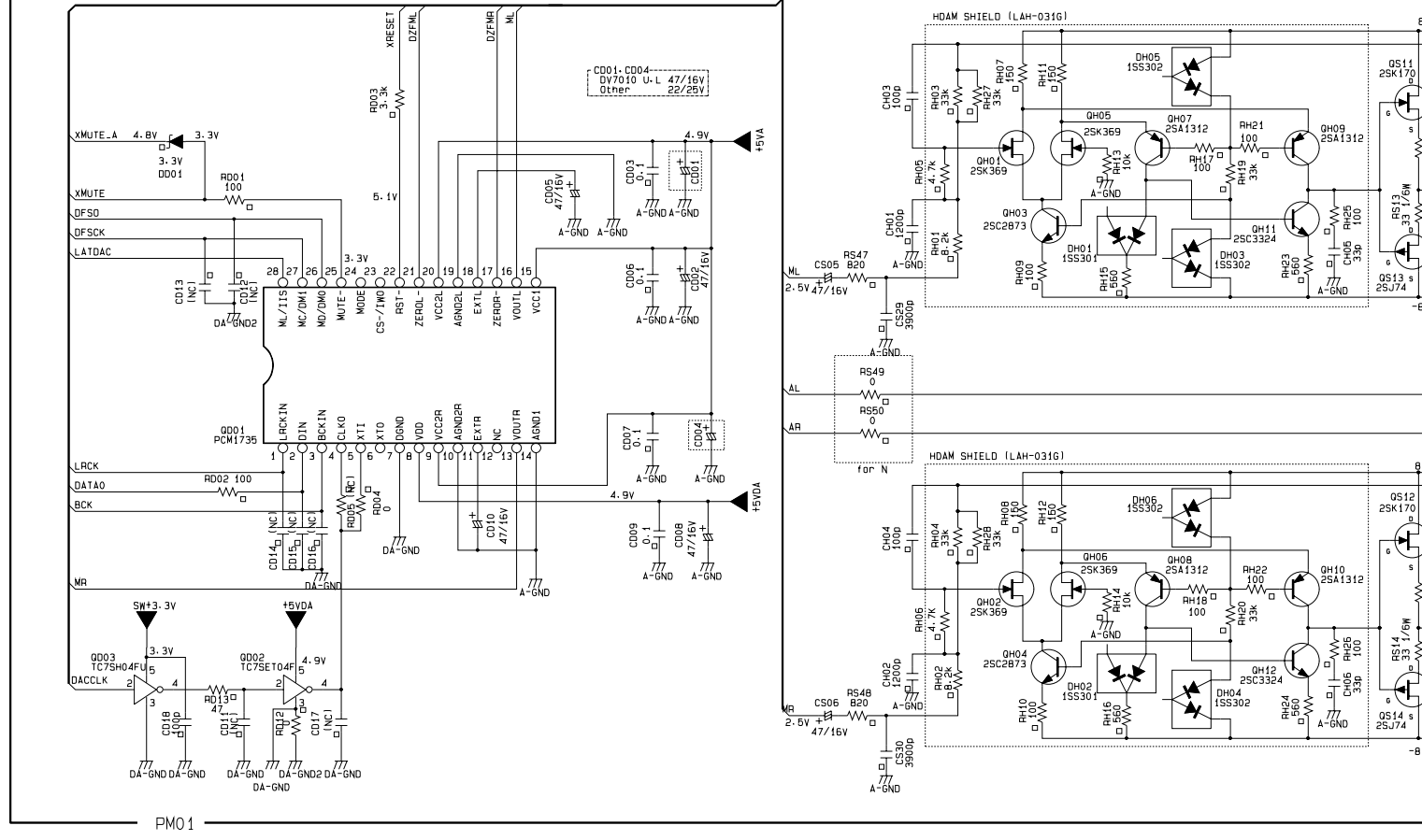
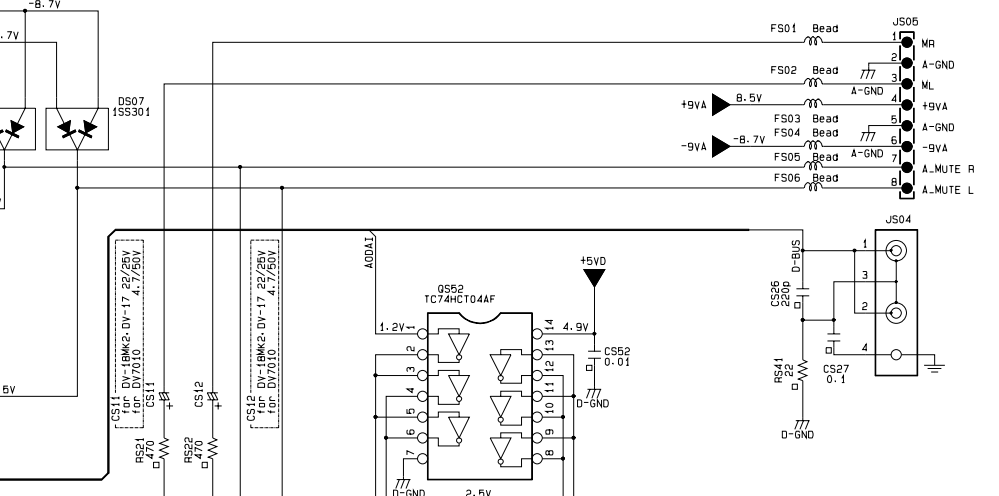
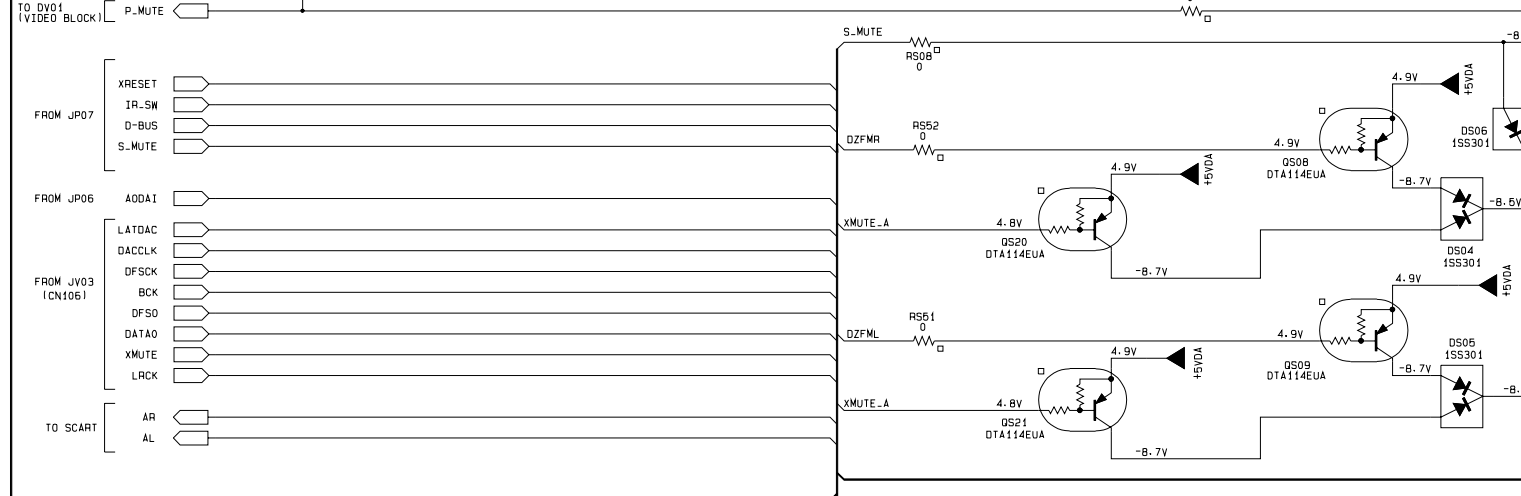
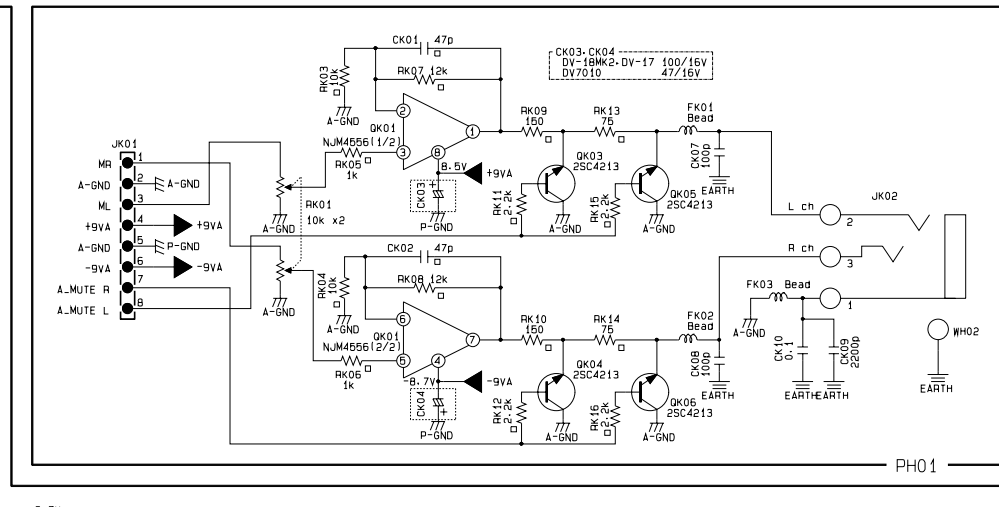
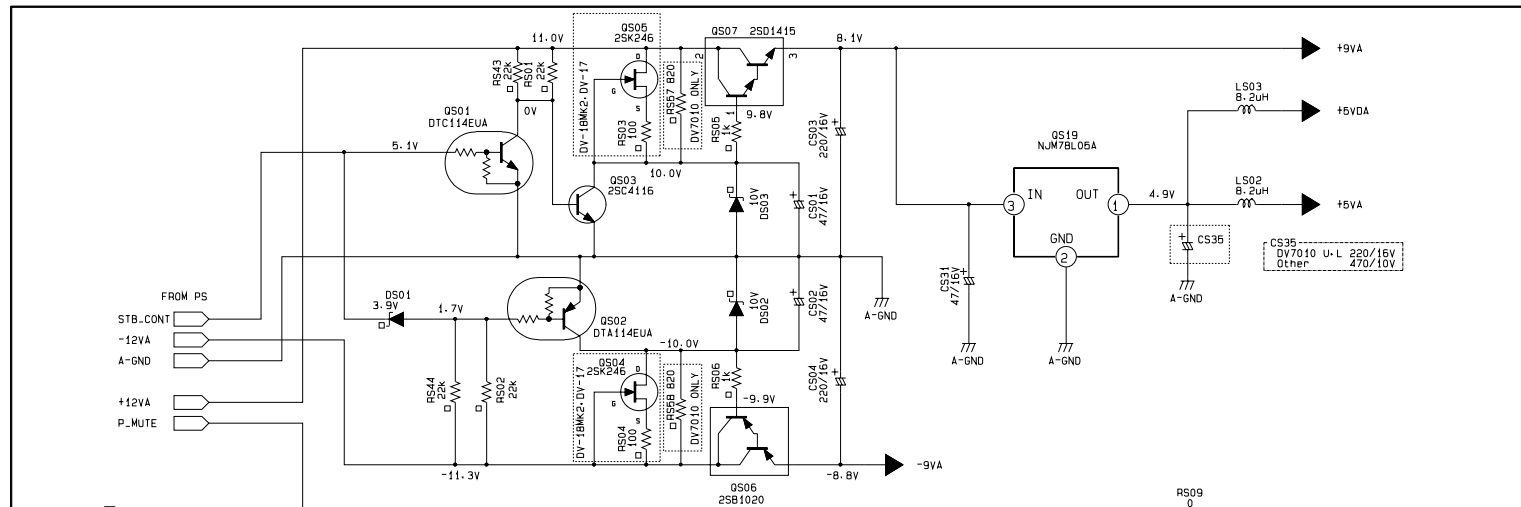

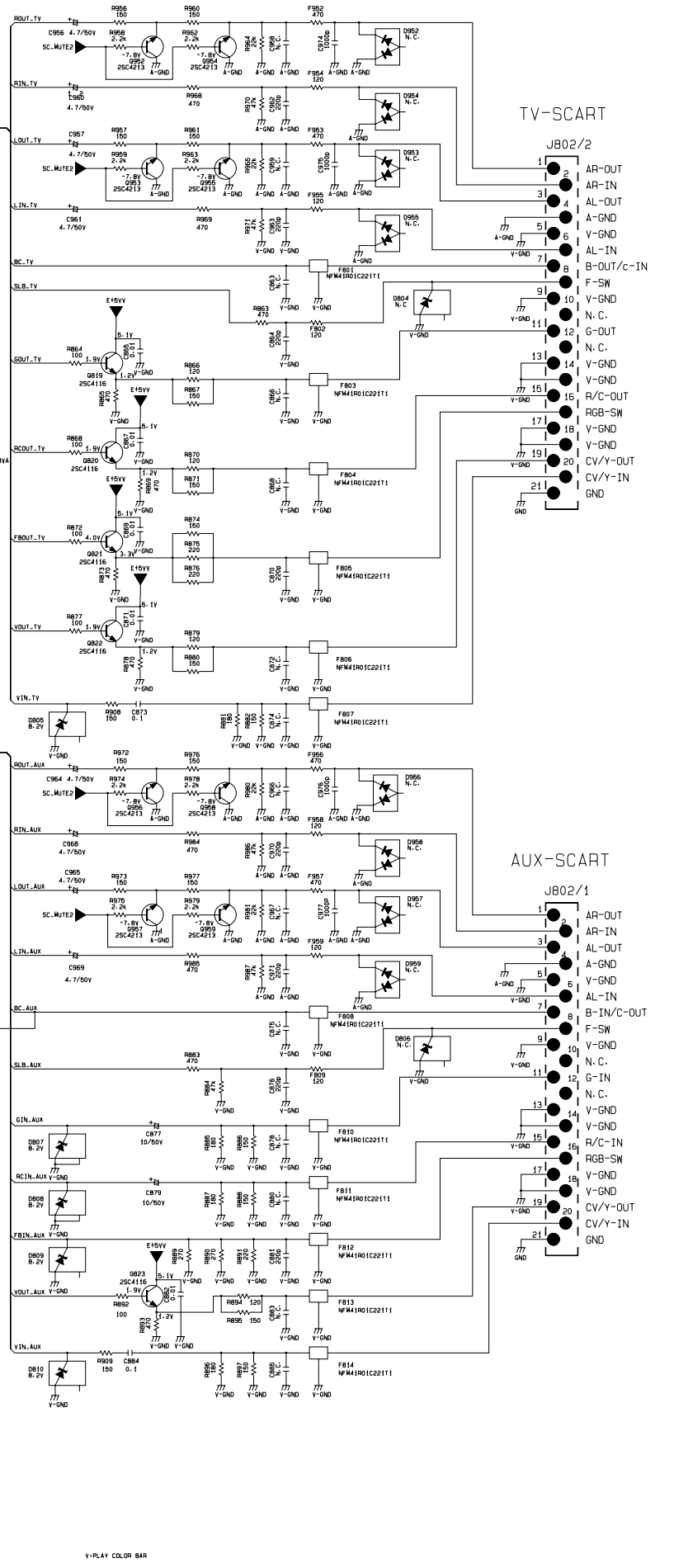
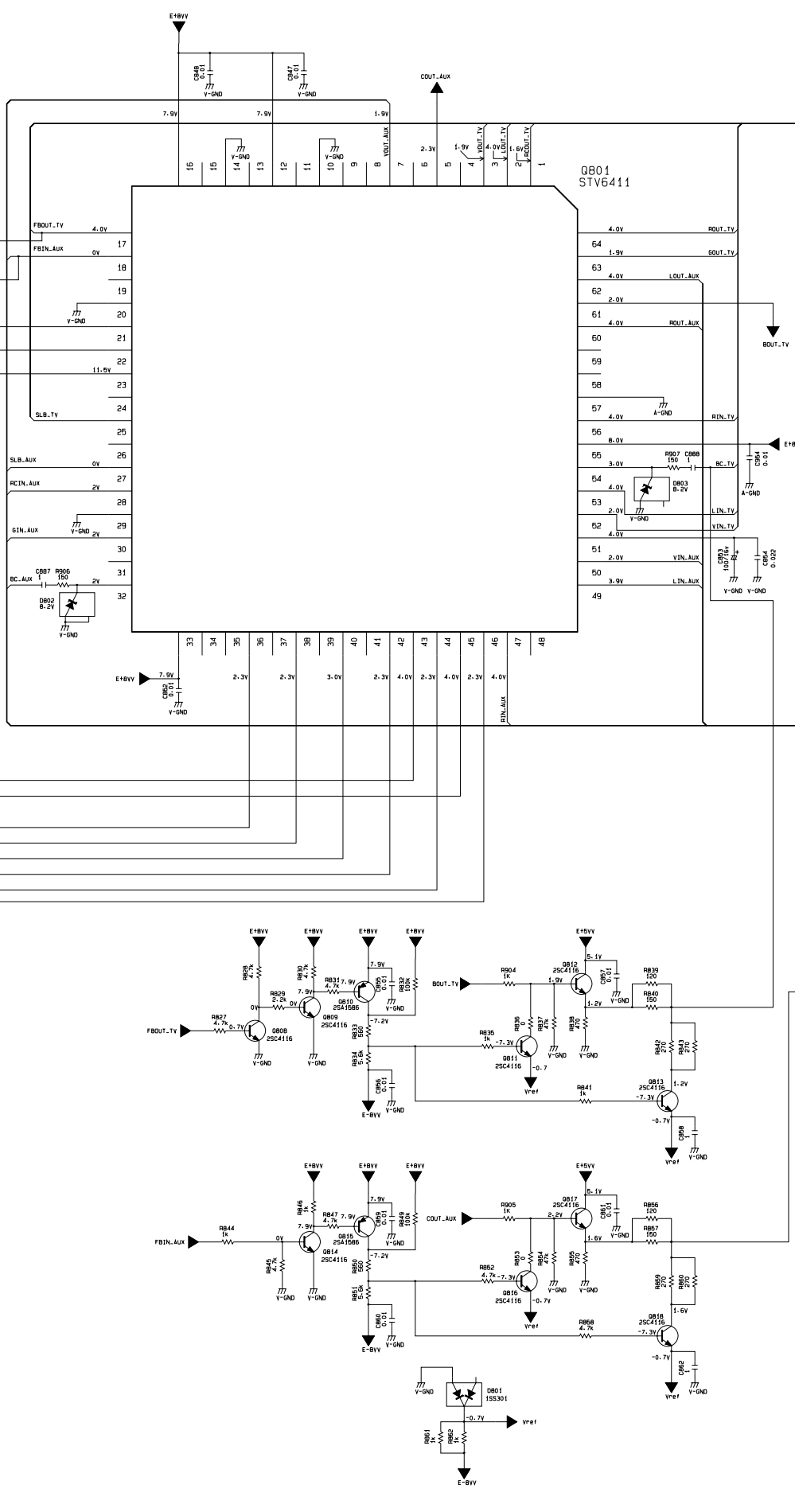
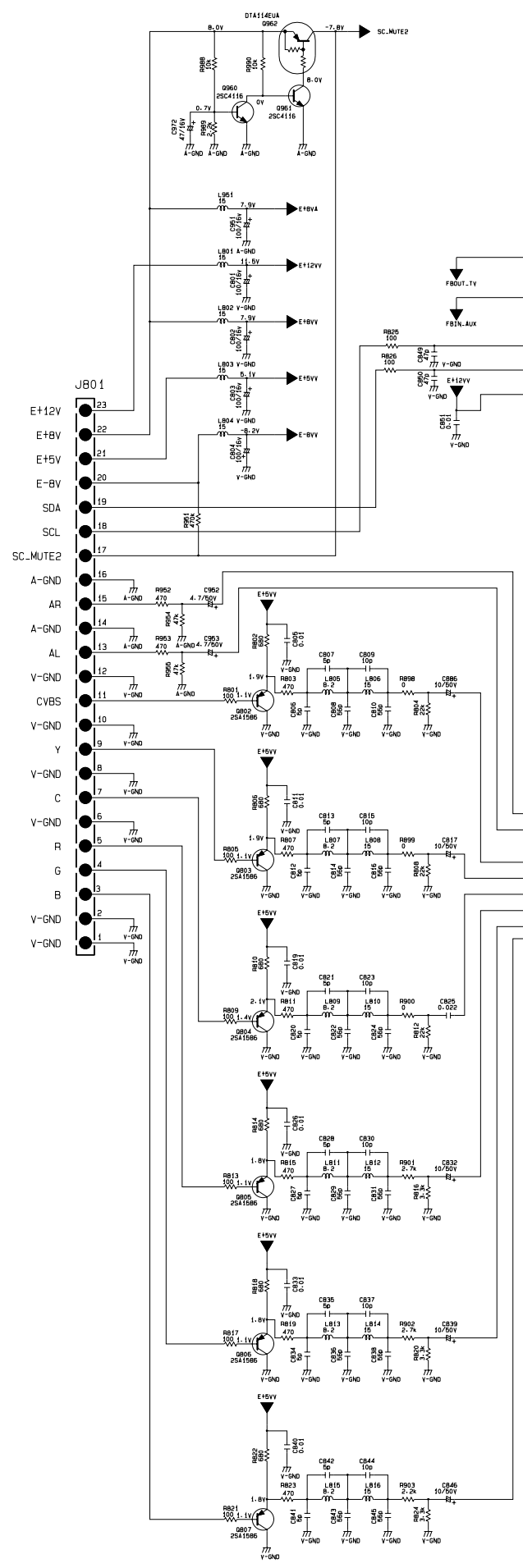

1.11 PARTS LOCATION
DV7010

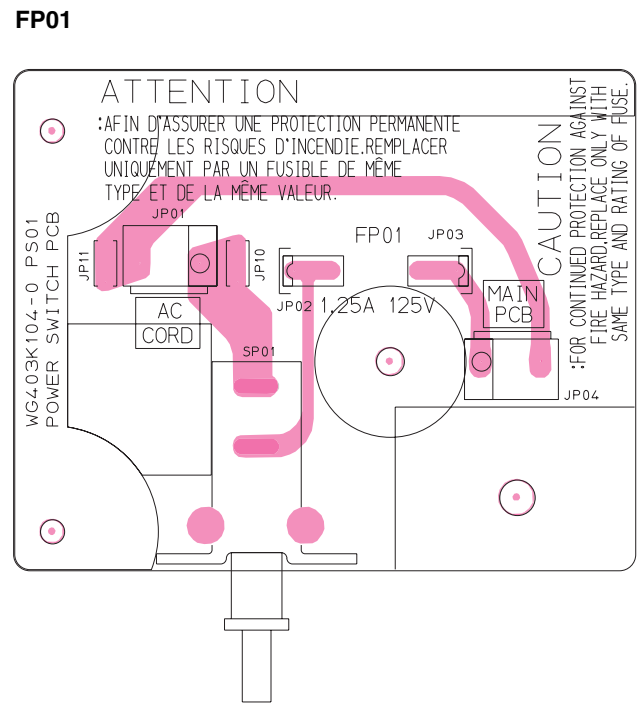
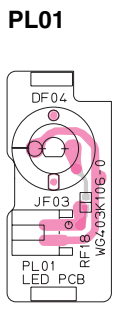
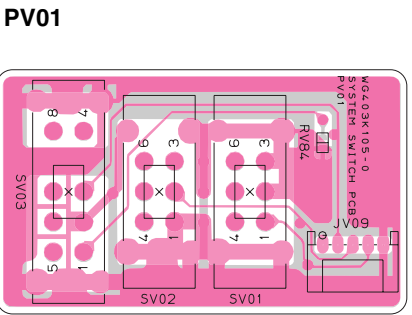
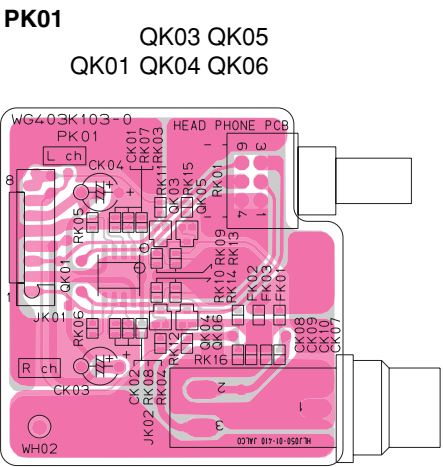
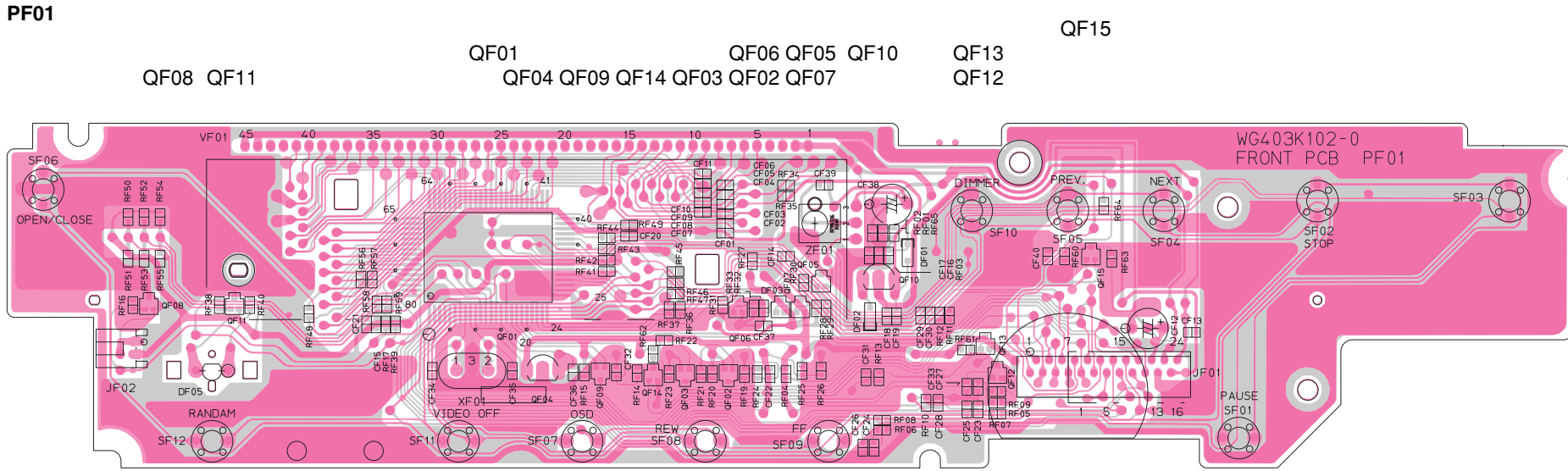

PF01

QF08 QF11

QF01
QF04

QF05 QF07
QF06 QF03 QF09
QF13 QF12 QF15 QF02 QF14

QF10

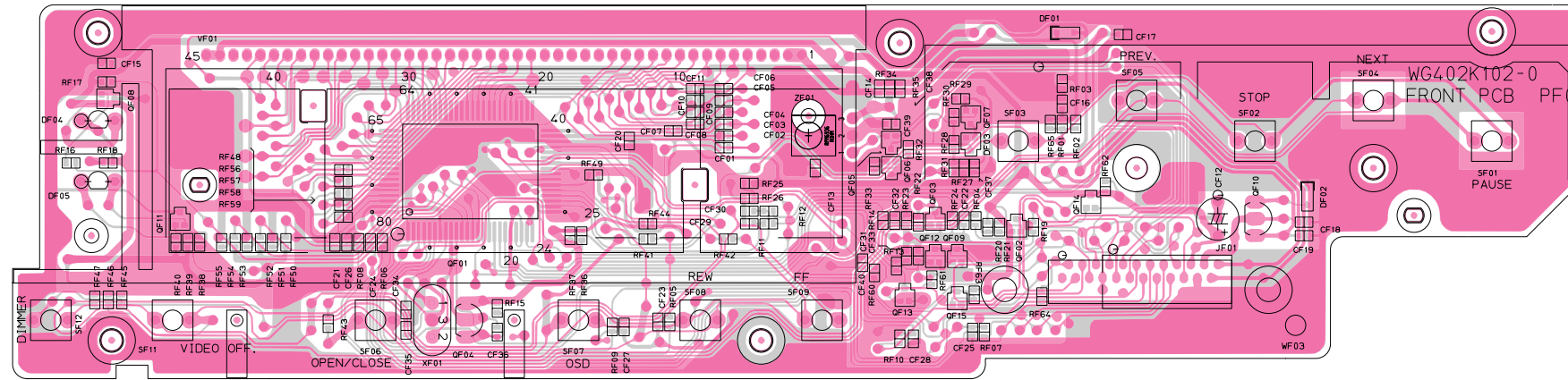

PK01

QK03 QK05
QK01 QK04 QK06

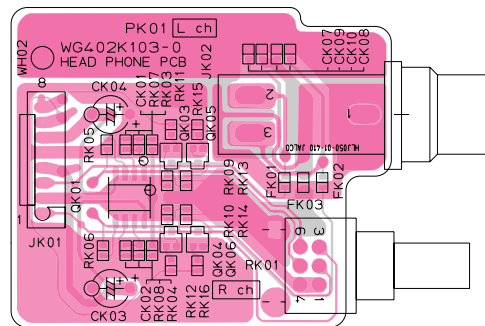

PV01

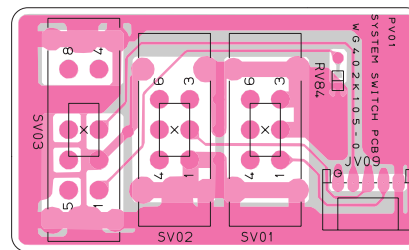

FP01

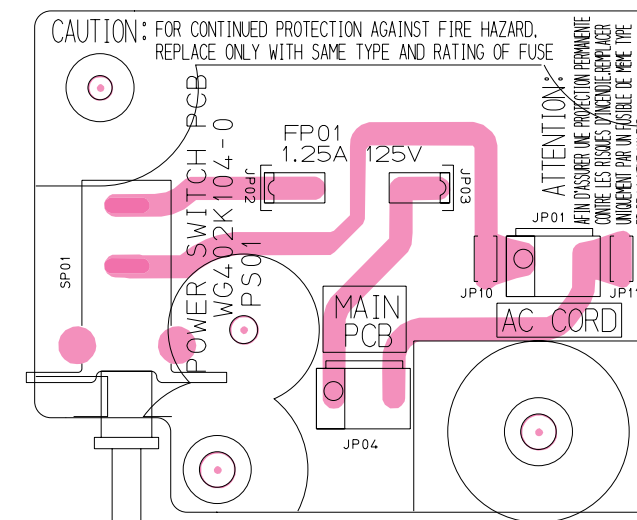

PM01

QP01 - QP05

QS06 QS07
QS01 - QS04

QP07 - QP10

QS19 QP06 QD01 QS08 QS09 QS20 QS21
QH04 QH02 QH06 QH05 QH01 QH03
QH10 QH12 QH08 QH07 QH11 QH09
QS14 QS12 QS11 QS13
QS15 - QS18

QP11 - QP17 QV50 QV51

QV13 - QV16 QP23 QP24

QD03

QV07 QV17 QV06 QV02 QV11
QV18 QC09 - QC11 QV03 QV12
QC12 QC01 QV01 QV10
QC04 - QC09 QC13 QC08 QC02

QS52

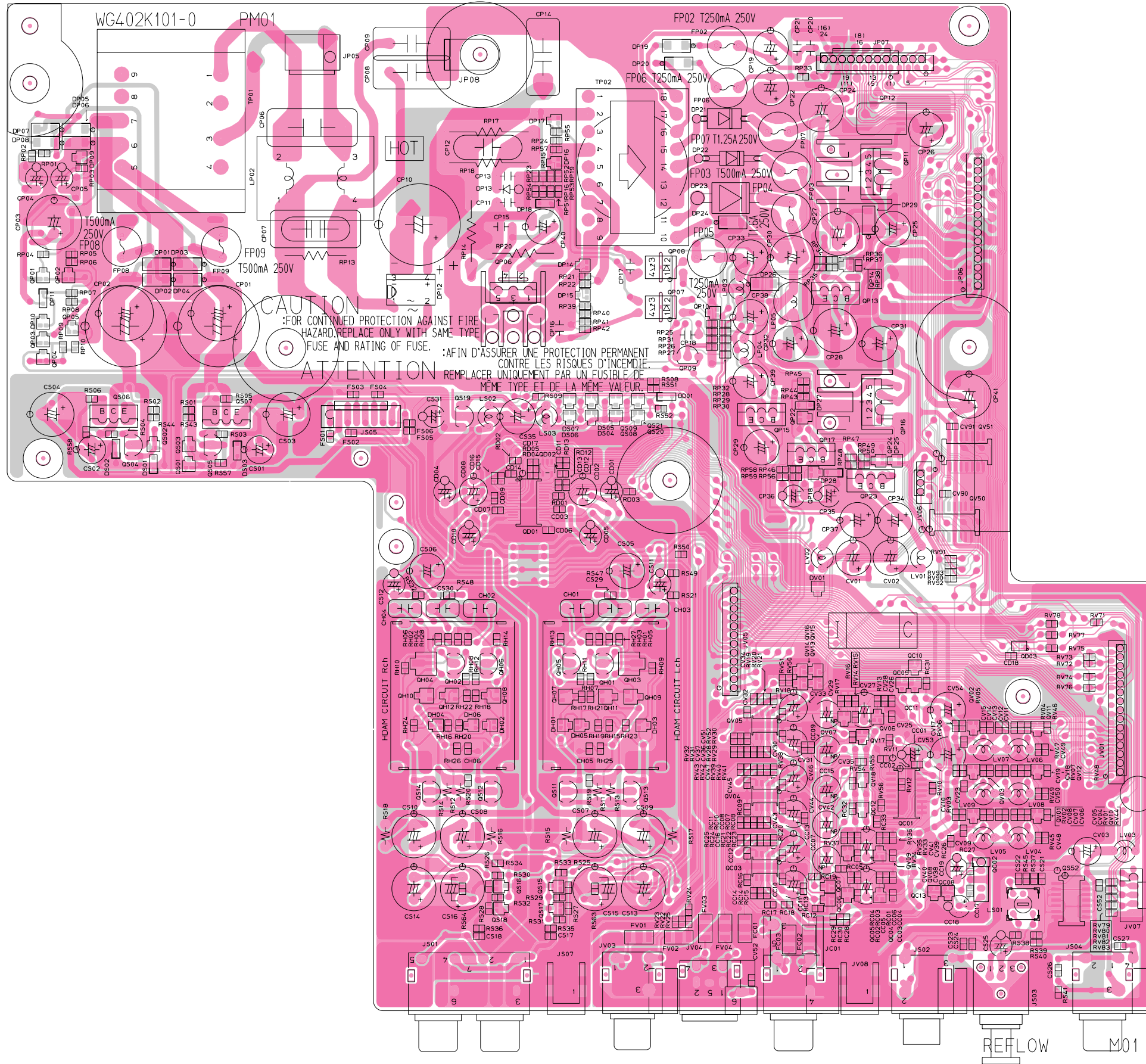

PE01

Q952 - Q955
Q960-Q962

Q956 - Q959

Q801

Q823

Q819 - Q821
Q808
Q809

Q814
Q815 - Q818

Q802 Q803 Q804 Q805 Q806 Q807

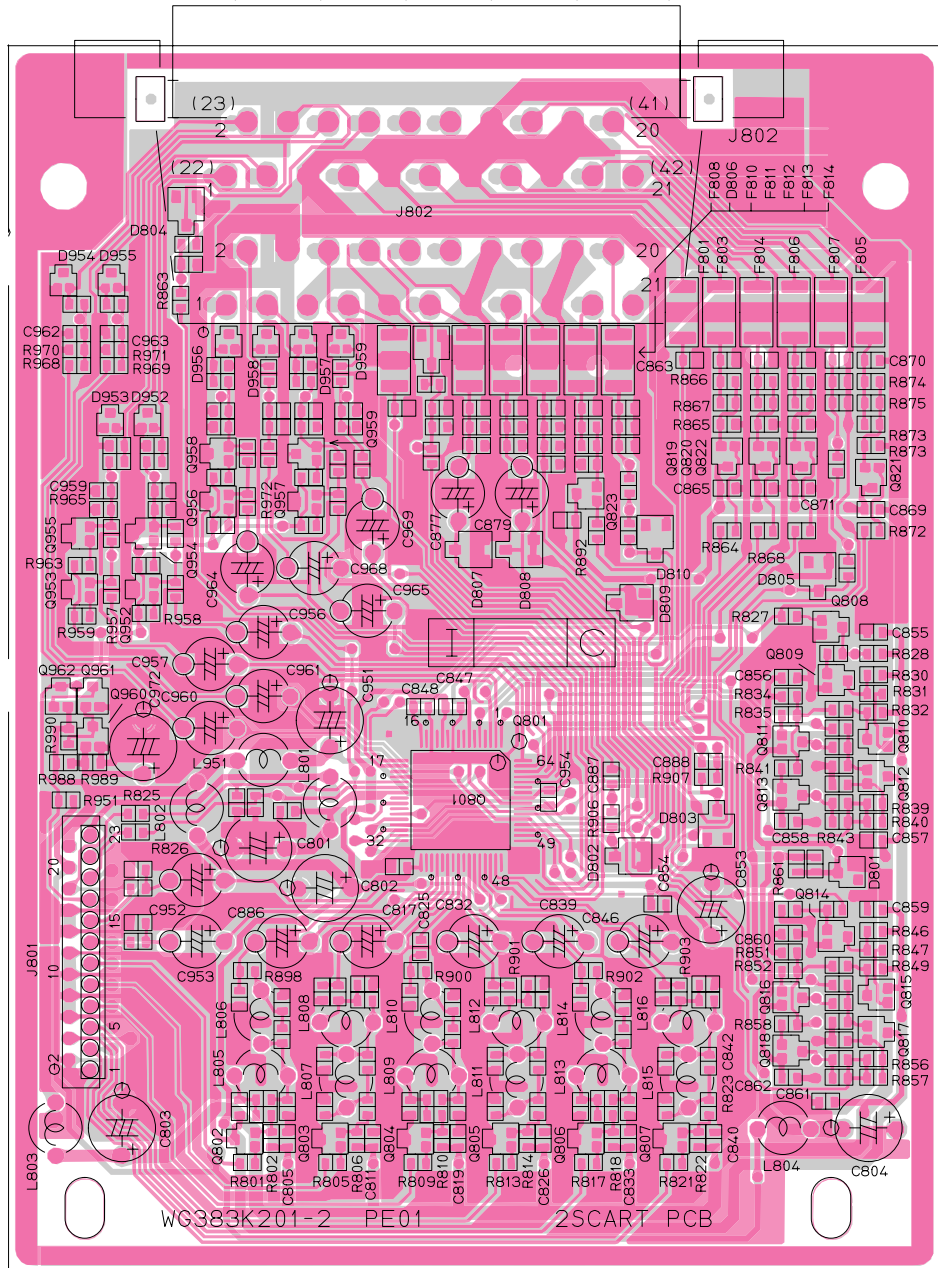

1.12 MICROPROCESSOR AND IC DATA

TMP87CH74

Pin No.	Port Name	I/O	FUNCTION
1	S OUT(F to M)	O	Serial data out put for Mecha unit
2	RESET_OUT	O	Reset signal for Mecha unit L:Reset
3	MODEL	I	GND
4	XRDY	O	Communication handshake line for Mecha unit d
5	SC_MUTE	O	Audio mute control for Scart L:Mute
6	SQUEEZE	I	16:9 squeeze signal from Mecha unit L:16:9, H:4:3
7	VSS		GND
8	XOUT	O	8MHz Osillater connecting
9	XIN	I	8MHz Osillater connecting
10	RESET	I	Reset signal input L:Reset
11	VERSION1	I	Destination setting
12	VERSION2	I	Destination setting
13	TEST		
14	VERSION3	I	Destination setting
15	S_MUTE	O	Audio mute control L:Mute
16	STB_LED	O	Standby LED control L:Standby
17	VSEL2	I	Video switching signal for Scart
18	STB_CONT	O	Standby control signal for Mecha unit L:Standby
19	V_MUTE	O	Video mute signal L:Mute
20	LT1	I	Communication response signal input from Mecha unit L:Busy, H:Ready
21	D_BUS_IN	I	Remote signal input
22	INT4/TC3	I	Remote signal input
23	SC_SCL	O	Serial clock output (I2C)
24	SC_SDA	I/O	Serial data input/output (I2C)
25	GND		
26	FL_OFF_LED	O	FL OFF LED control L:Standby
27	KEY IN0	I	Key scan input
28	KEY IN1	I	Key scan input
29	KEY IN2	I	Key scan input
30	Reserve	I	Reserve (5V)
31	VSEL1	I	Video switching signal for Scart
32	REM_CODE	I	Remote code setting
33	GND		GND
34	KEY OUT0	O	Key scan output
35	KEY OUT1	O	Key scan output
36	KEY OUT2	O	Key scan output
37	KEY OUT3	O	Key scan output
38	GND		GND
39	+5V	I	A/D Reference voltage
40	+5V		Power supply
41	NC		
42	NC		
43	G11	O	VFT Grid output
44	G10	O	VFT Grid output
45	G9	O	VFT Grid output
46	G8	O	VFT Grid output
47	G7	O	VFT Grid output
48	G6	O	VFT Grid output
49	G5	O	VFT Grid output
50	G4	O	VFT Grid output
51	G3	O	VFT Grid output
52	G2	O	VFT Grid output
53	G1	O	VFT Grid output
54	NC		
55	NC		
56	NC		
57	P21	O	VFT Segment output
58	P20	O	VFT Segment output

Pin No.	Port Name	I/O	FUNCTION
59	P19	O	VFT Segment output
60	P18	O	VFT Segment output
61	P17	O	VFT Segment output
62	P16	O	VFT Segment output
63	P15	O	VFT Segment output
64	P14	O	VFT Segment output
65	P13	O	VFT Segment output
66	P12	O	VFT Segment output
67	P11	O	VFT Segment output
68	P10	O	VFT Segment output
69	P9	O	VFT Segment output
70	P8	O	VFT Segment output
71	P7	O	VFT Segment output
72	P6	O	VFT Segment output
73	P5	O	VFT Segment output
74	P4	O	VFT Segment output
75	P3	O	VFT Segment output
76	P2	O	VFT Segment output
77	P1	O	VFT Segment output
78	VKK		VFT Powewr supply
79	SCK	O	Serial clock output for Mecha unit
80	SIN(M to F)	I	Serial data input from Mecha unit

TMP87CH74

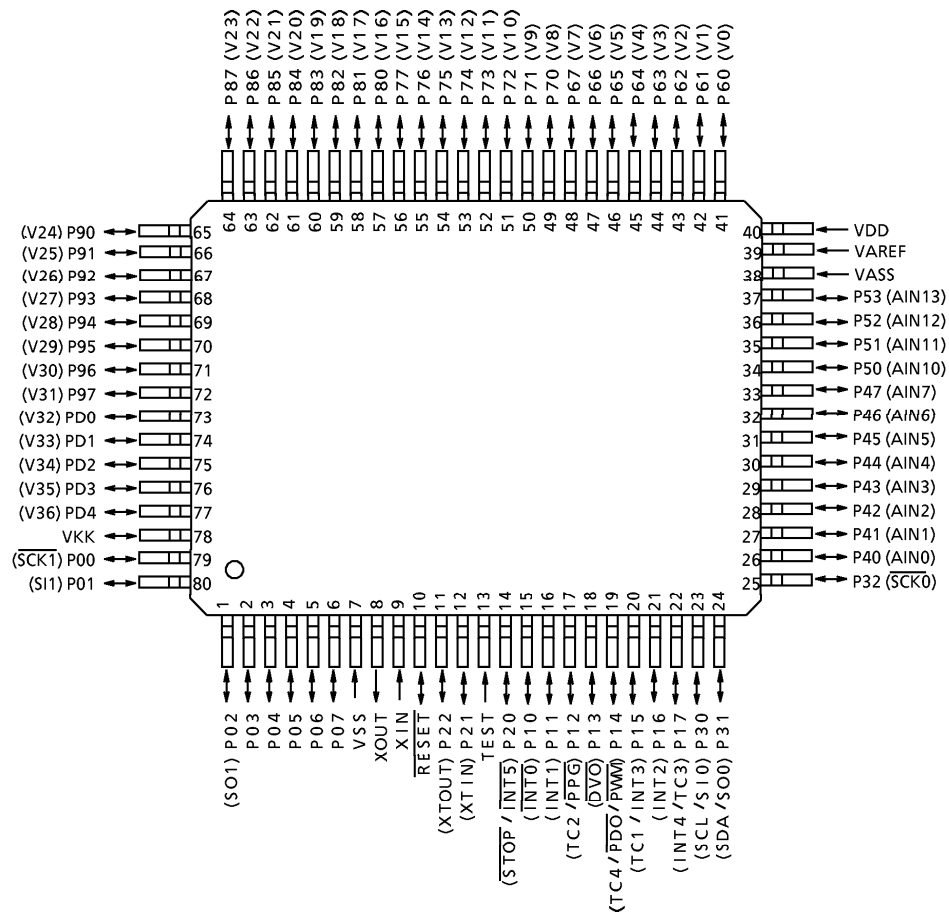

PCM1735

Pin No.	Port Name	I/O	FUNCTION
1	LRCK	I	LRCK Clock Input (fs). (1)
2	DATA	I	Serial Audio Data Input. (1)
3	BCK	I	Bit Clock Input for Serial Audio Data. (1)
4	CLKO	O	Buffered Output of System Clock.
5	XTI	I	Oscillator Input / External Clock Input.
6	XTO	O	Oscillator Output.
7	DGND	-	Digital Ground.
8	V _{DD}	-	Digital Power. + 5 V
9	V _{CC2R}	-	Analog Power. + 5V
10	AGND2R	-	Analog Ground.
11	EXTR	O	Rch, Common Pin of Analog Output Amp.
12	NC	-	Non Connection.
13	V _{OUTR}	O	Rch, Analog Voltage Output of Audio signal.
14	AGND1	-	Analog Ground.
15	V _{CC1}	-	Analog Power. + 5 V
16	V _{OUTL}	O	Lch, Analog Voltage Output of Audio signal.
17	ZEROR	O	Rch Zero Data Flag (Open Drain)
18	EXTL	O	Lch, Common Pin of Analog Output Amp
19	AGND2L	-	Analog Ground.
20	V _{CC2L}	-	Analog Power. + 5 V
21	ZEROL	O	Lch Zero Data Flag (Open Drain)
22	RST	I	Reset. When this pin is LOW, the DF & modulators are held in reset. (2)
23	CS / IWO	I	Chip Select / Input format selection. (3)
24	MODE	I	Mode Control Select. (H: Software, L: Hard ware) (2)
25	MUTE	I	Mute Control. (2)
26	MD / DM0	I	Mode Control, Data / De-emphasis selection 1. (2)
27	MC / DM1	I	Mode Control, BCK / De-emphasis selection 2. (2)
28	ML / IIS	I	Mode Control, WDCK / Input format selection. (2)

(1) Pins 1, 2, 3: Schmitt-trigger input.

(2) Pins 22, 24, 25, 26, 27, 28: Schmitt-trigger input with internal pull-up.

(3) Pin 23: Schmitt-trigger input with internal pull-down.

PCM1735

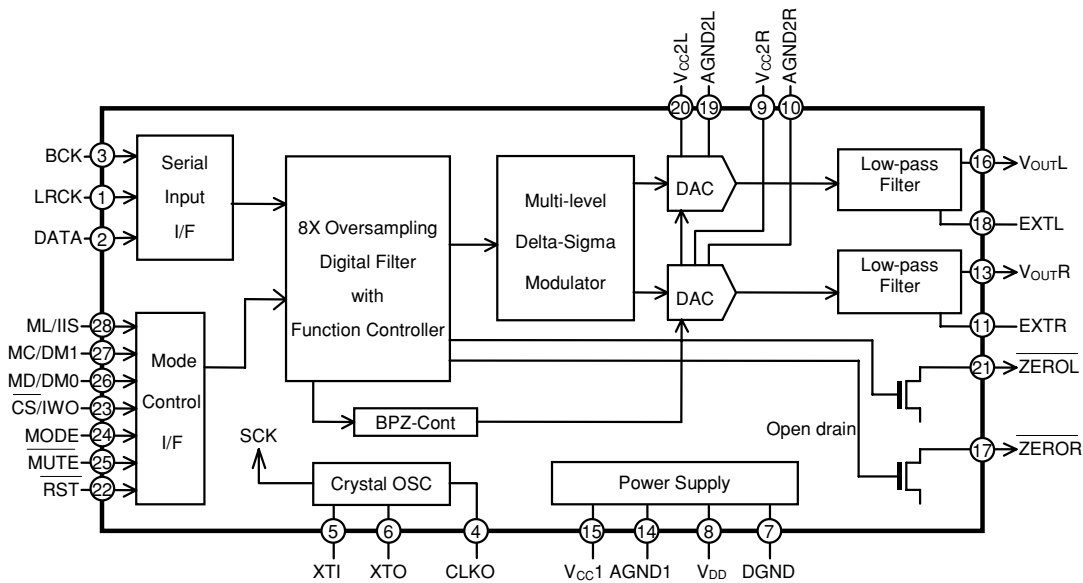

1.13 EXPLODED VIEW AND PARTS LIST DV7010

SYMBOL	STYLE	PARTS NAME
5110		+B.H.M.SCREW
5126		+B.H.TAP TITE SCREW W/WASHER
5127		+P.H.TAP TITE SCREW(BTYPE)
5128		+B.H.TAP TITE SCREW(BTYPE)
5129		+B.H.TAP TITE SCREW(W/T.L.WASHER)

MARK	MATERIAL/FINISH
(M)	STEEL/COPPER
(U)	STEEL/BLACK

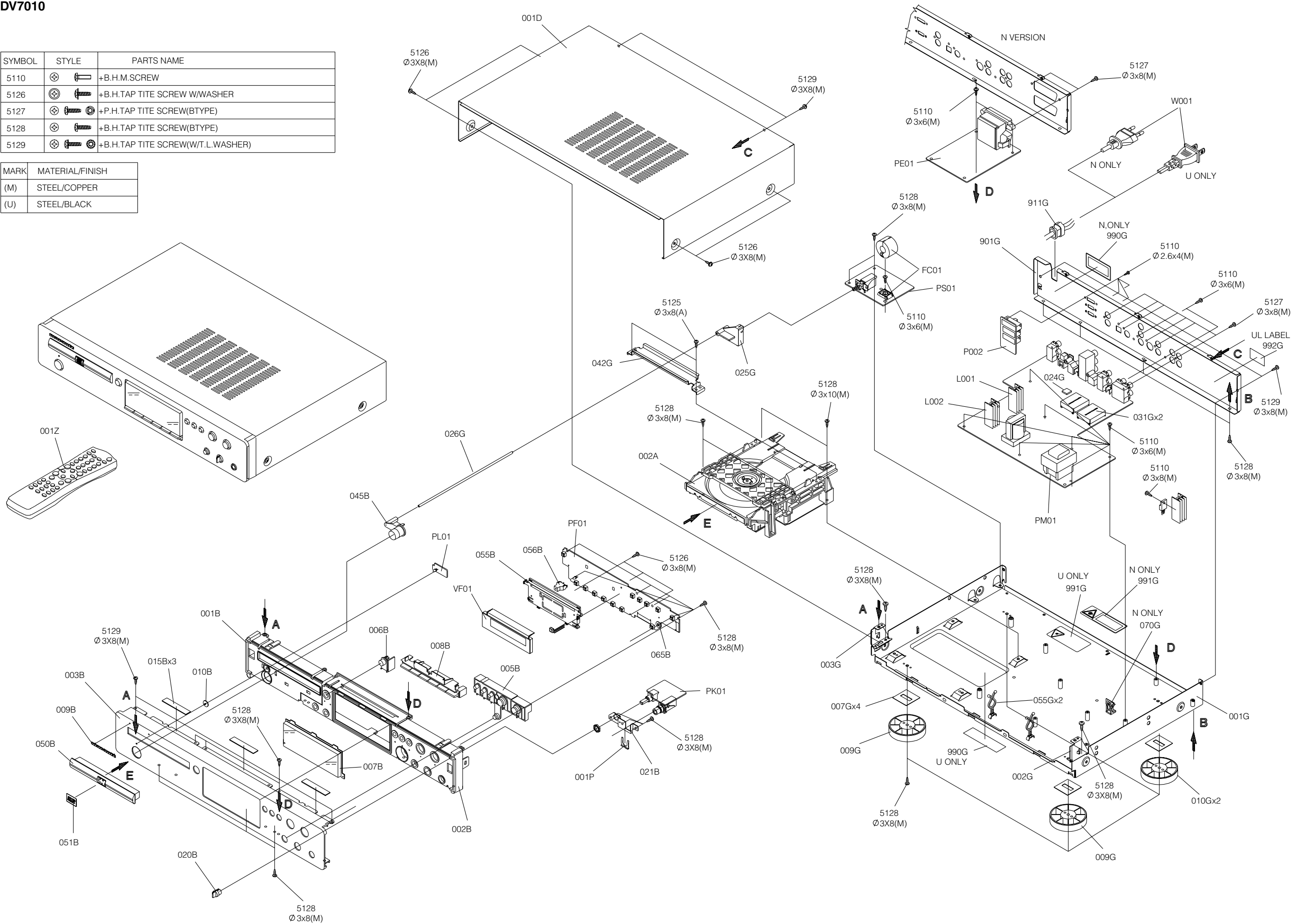

DV-18mklI

SYMBOL	STYLE	PARTSNAME
5110		+B.H.M.SCREW
5126		+B.H.TAP TITE SCREW W/WASHER
5127		+P.H.TAP TITE SCREW(BTYPE)
5128		+B.H.TAP TITE SCREW(BTYPE)
5129		+B.H.TAP TITE SCREW(W/T.L.WASHER)
5150		+F.H.TAP TITE SCREW(BTYPE)
5159		+B.H.TAP TITE SCREW(STYPE)

MARK	MATERIAL/FINISH
(M)	STEEL/COPPER
(U)	STEEL/BLACK
(A)	STEEL/CHROMATE

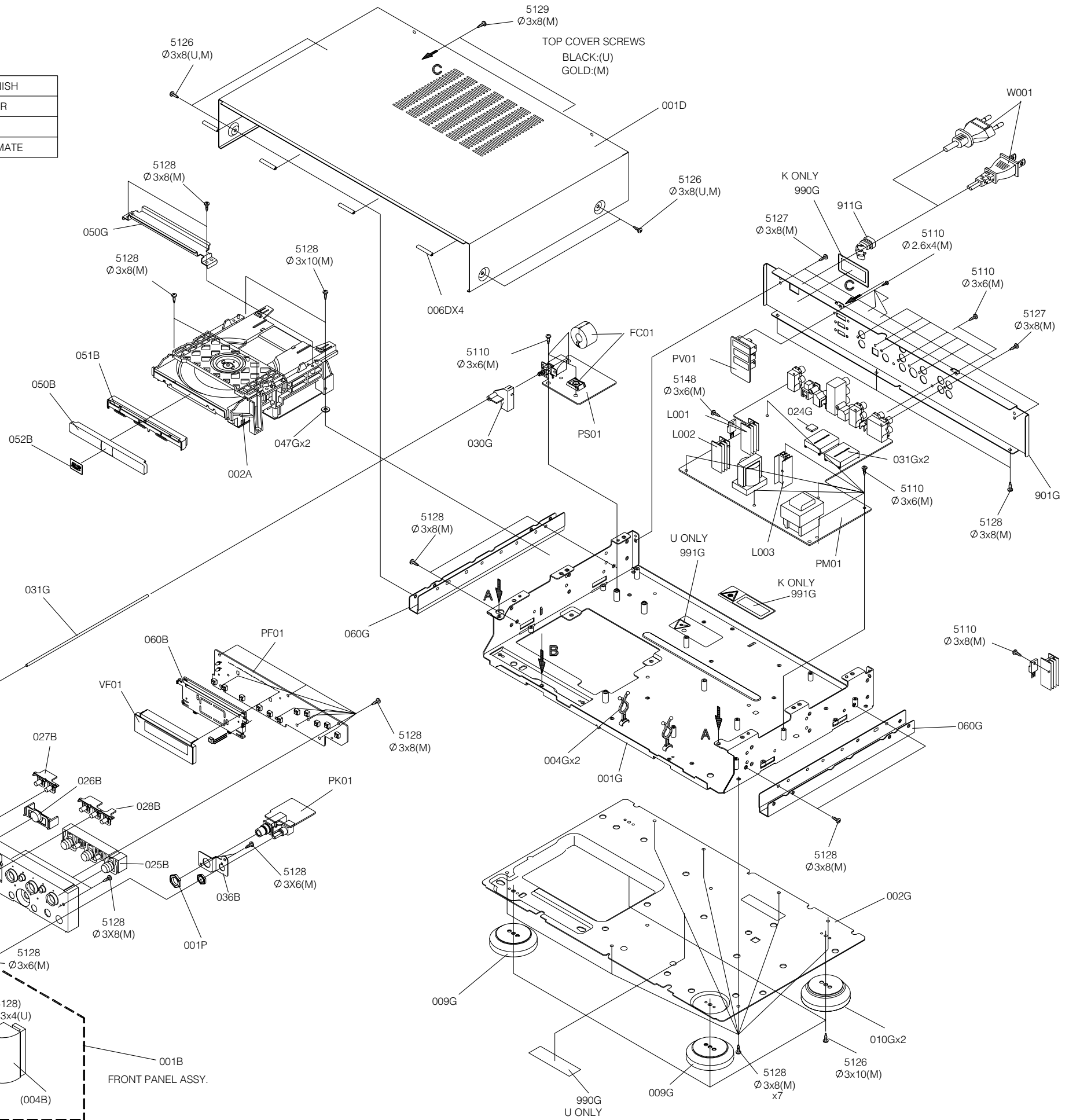
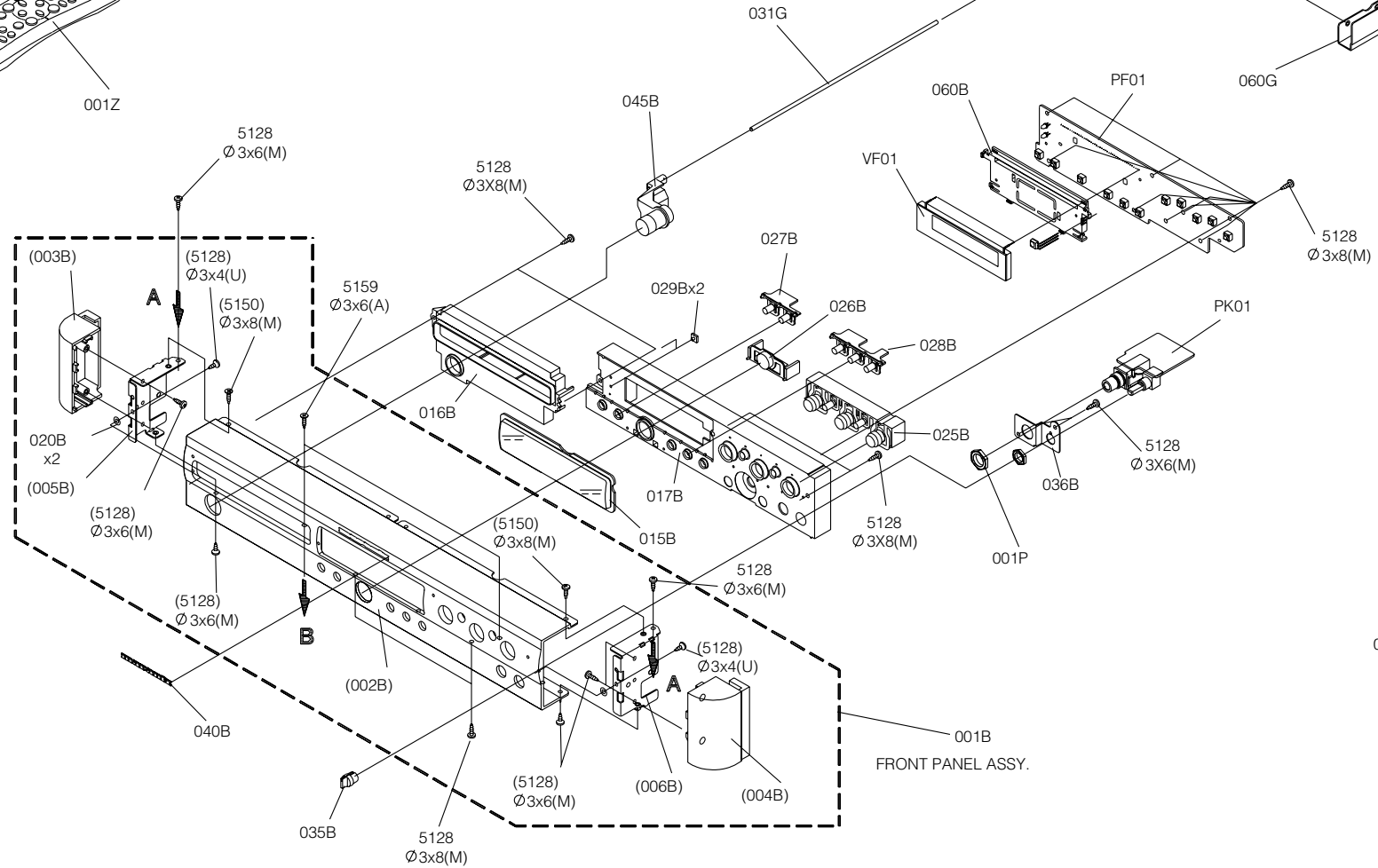
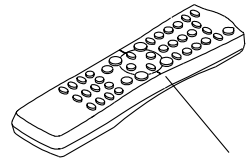
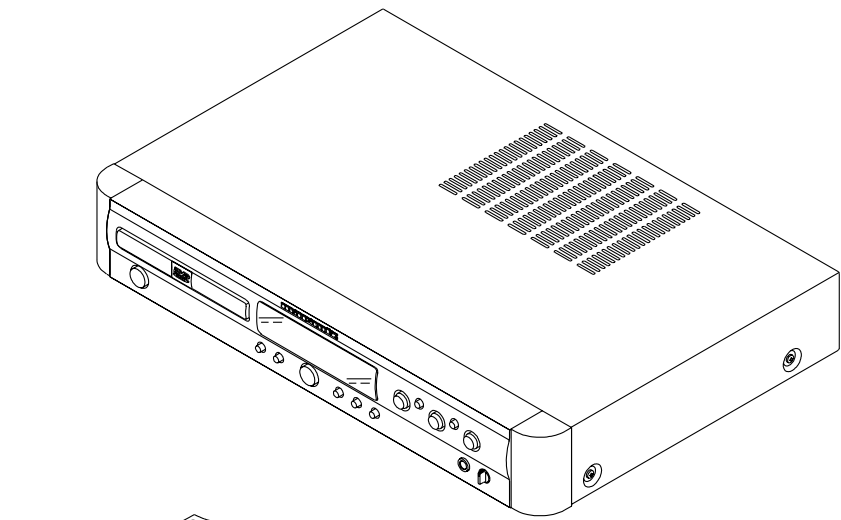

SYMBOL	STYLE	PARTS NAME
5110		+B.H.M.SCREW
5126		+B.H.TAP TITE SCREW W/WASHER
5127		+P.H.TAP TITE SCREW(BTYPE)
5128		+B.H.TAP TITE SCREW(BTYPE)
5129		+B.H.TAP TITE SCREW(W/T.L.WASHER)
5150		+F.H.TAP TITE SCREW(BTYPE)
5159		+B.H.TAP TITE SCREW(STYPE)

MARK	MATERIAL/FINISH
(M)	STEEL/COPPER
(U)	STEEL/BLACK
(A)	STEEL/CHROMATE

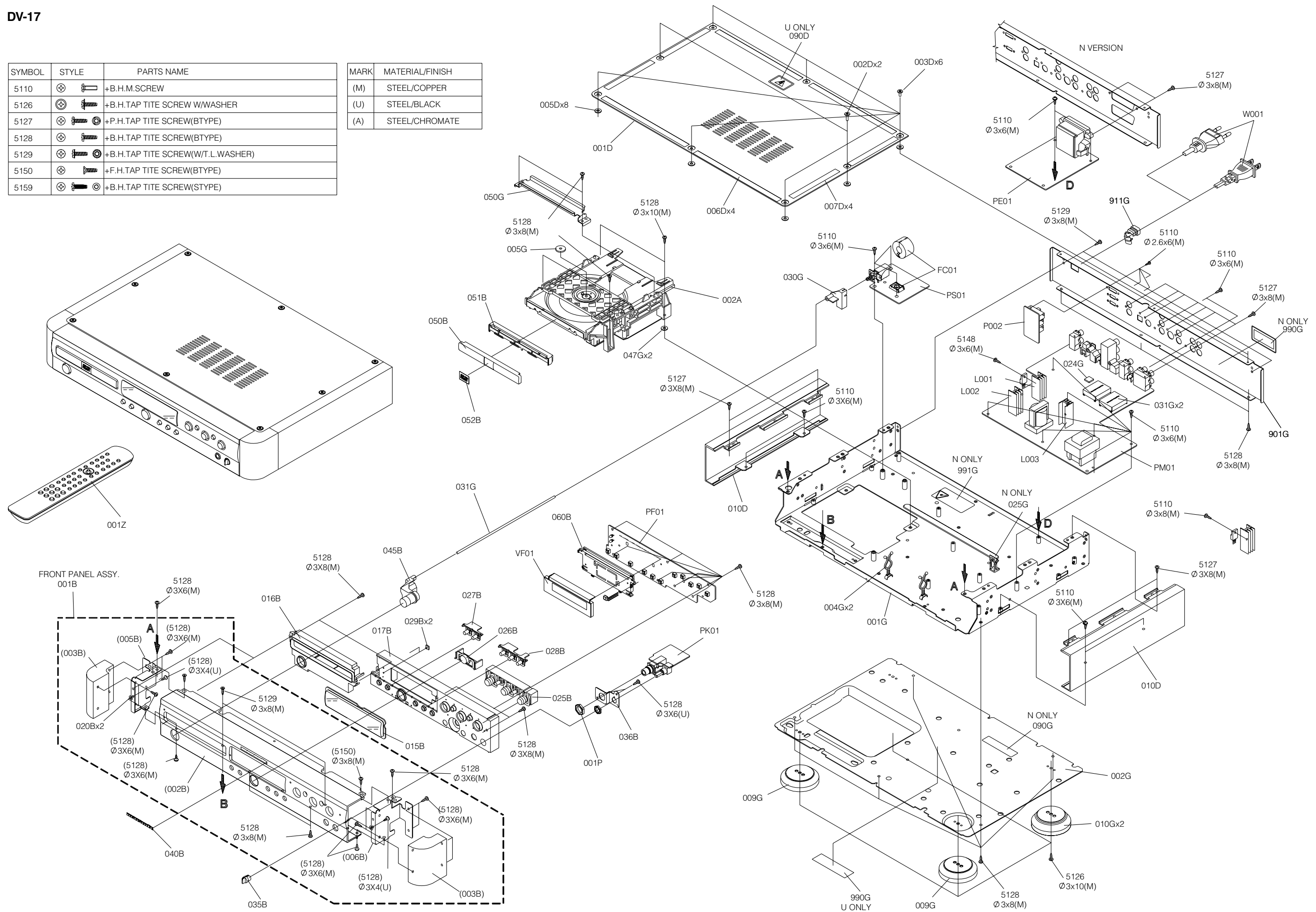

DV7010

POS. NO	VERS. COLOR	PART NO. (PCS)	DESCRIPTION	PART NO. (MJI)
001B	BLACK	9965 000 07791	FRONT CHASSIS BLACK	403K105020
001B	GOLD	9965 000 07803	FRONT CHASSIS GOLD	403K105120
002B	BLACK	9965 000 05016	FRONT CHASSIS BLACK	383K105020
002B	GOLD	9965 000 05017	FRONT CHASSIS GOLD	383K105120
003B	BLACK	9965 000 07792	FRONT PANEL BLACK	403K248010
003B	GOLD	9965 000 07804	FRONT PANEL GOLD	403K248110
005B	BLACK	9965 000 05020	BUTTON FUNCTION BLACK	383K270010
005B	GOLD	9965 000 05021	BUTTON FUNCTION GOLD	383K270110
006B	BLACK	9965 000 05022	BUTTON OPEN/CLOSE BLACK	383K270020
006B	GOLD	9965 000 05023	BUTTON OPEN/CLOSE GOLD	383K270120
007B		9965 000 07793	WINDOW	383K158030
008B		9965 000 05025	BUTTON SUB FUNCTION	386K270090
009B		9965 000 07461	BADGE MARANTZ BLACK	185J251010
010B		9965 000 01393	LENS STANDBY	312J355010
020B	BLACK	4822 411 20336	KNOB PHONE BLACK	284T154310
020B	GOLD	9965 000 00580	KNOB PHONE GOLD	284T154240
045B	BLACK	9965 000 07794	BUTTON POWER BLACK	403K270010
045B	GOLD	9965 000 07805	BUTTON POWER GOLD	403K270110
050B	BLACK	9965 000 07795	ESCUTCHEON TRAY FRONT BLACK	403K063010
050B	GOLD	9965 000 07806	ESCUTCHEON TRAY FRONT GOLD	403K063110
051B	BLACK	9965 000 05028	BADGE DVD BLACK	386K251030
051B	GOLD	9965 000 05029	BADGE DVD GOLD	386K251130
009G		9965 000 05030	LEG FRONT	383K057010
010G		9965 000 05031	LEG REAR	383K057110
025G		9965 000 07796	LINK POWER BUTTON	403K121010
026G		9965 000 07623	SHAFT POWER BUTTON	403K112010
911G	/A,/C,/L,/N /S,/U	4822 532 60948	BUSHING MAINS CORD	450H259010
911G	/F		BUSHING MAINS CORD	318K259020
▲ W001	/A		MAINS CORD 7.5A 250V SAA	YC01800630
▲ W001	/C		MAINS CORD 3A 250V	YC02000820
▲ W001	/F		MAINS CORD 15A 125V OFC	YC01800430
▲ W001	/L		MAINS CORD 10A 250V CCEE	YC01800880
▲ W001	/N,/S	4822 321 11343	MAINS CORD 2.5A 250V	YC01800790
▲ W001	/U		MAINS CORD	YC02000880
001T	/A,/U		PACKING USER GUIDE (A.U)	403K851250
001T	/C,/L,/S		USER GUIDE (C S L)	403K851350
001T	/F		USER GUIDE (JPN)	403K851110
001T	/N	9965 000 07797	USER GUIDE (EURO)	403K851310
001Z		9965 000 07802	REMOTE CONTROLLER RC7010DV	ZK403K0010
001S			NOT STANDARD SPARE PARTS PACKING CASE	403K801010
002S			CUSHION	386K809010

DV-18mkII/DV-17

POS. NO	VERS. COLOR	PART NO. (PCS)	DESCRIPTION	PART NO. (MJI)	POS. NO	VERS. COLOR	PART NO. (PCS)	DESCRIPTION	PART NO. (MJI)
001B	17 GOLD		FRONT PANEL ASSY GOLD	405K248510	009G	17	9965 000 07621	LEG FRONT GOLD	405K057010
001B	17 BLACK		FRONT PANEL ASSY BLACK	405K248500	010G	17	4822 462 42134	LEG REAR GOLD	291K057010
002B	17 GOLD	9965 000 07650	FRONT PANEL GOLD	405K248110	009G	18A		LEG D60/H15 GOLD PEF/PORON.F	402K057010
002B	17 BLACK	9965 000 07613	FRONT PANEL BLACK	405K248010	010G	18A		LEG D60/H18 GOLD PEF/PORON.R	370K057120
003B	17 GOLD	4822 444 40853	ESCUTCHEON CORNER COLUMN GOLD	318K063110	025G	17 /N		SUPPORT EURO CONNECTOR	349K101010
003B	17 BLACK	4822 444 40852	ESCUTCHEON CORNER COLUMN BLACK	318K063010	030G		9965 000 07622	LINK POWER BUTTON (BL OR BR)	402K121010
001B	18A GOLD		FRONT PANEL ASSY GOLD	402K248510	031G		9965 000 07623	SHAFT POWER BUTTON	403K112010
001B	18A BLACK		FRONT PANEL ASSY BLACK	402K248500	911G	17 /F		BUSHING MAINS CORD	1455259210
002B	18A GOLD		FRONT PANEL GOLD	402K248110	911G	17 /S,/N	4822 532 60948	BUSHING MAINS CORD	450H259010
002B	18A BLACK		FRONT PANEL BLACK	402K248010	911G	18A		BUSHING MAINS CORD	450H259010
003B	18A GOLD		ESCUTCHEON CORNER COLUMN PL LEFT GOLD	342K063110	▲ W001	17 /F		MAINS CORD 15A 125V OFC	YC01800430
003B	18A BLACK		ESCUTCHEON CORNER COLUMN PL LEFT BLACK	342K063010	▲ W001	17 /S		MAINS CORD 5A 250V	YC01800760
004B	18A GOLD		ESCUTCHEON CORNER COLUMN PL RIGHT GOLD	342K063120	▲ W001	17 /N	4822 321 11343	MAINS CORD 2.5A 250V	YC01800790
004B	18A BLACK		ESCUTCHEON CORNER COLUMN PL RIGHT BLACK	342K063020	▲ W001	18A /A		MAINS CORD 7.5A 250V FIX(SAA)	YC01800630
015B	GOLD	9965 000 07651	WINDOW PINK SMOKE GOLD	318K158150	▲ W001	18A /C		MAINS CORD KOREA 3A 250V	YC02000820
015B	BLACK	9965 000 07614	WINDOW BLUE SMOKE BLACK	318K158050	▲ W001	18A /K,/L		MAINS CORD CCEE APP.(AC250V 10A)+VAR2P	YC01800880
016B	GOLD	9965 000 07652	BUSHING FOR TRAY OPENING GOLD	402K259110	▲ W001	18A /S		MAINS CORD FOR BS(MAYOR)	YC01800760
016B	BLACK	9965 000 07615	BUSHING FOR TRAY OPENING BLACK	402K259010	▲ W001	18A /U		MAINS CORD UL/CSA NON-INTEGRAL	YC02000880
017B	GOLD	9965 000 07656	RETAINER FRONT PCB HOLDER GOLD	370K104110				PACKING USER GUIDE (JPN)	405K851110
017B	BLACK	9965 000 07616	RETAINER FRONT PCB HOLDER BLACK	370K104010	001T	17 /F		USER GUIDE DV-17K	405K851350
025B	GOLD	9965 000 00563	BUTTON PLAY/STOP/PAUSE GOLD	362K270150	001T	17 /S	9965 000 07624	USER GUIDE (EURO)	405K851310
025B	BLACK	9965 000 00562	BUTTON PLAY/STOP/PAUSE BLACK	362K270050	001T	17 /N		USER GUIDE (EURO)	405K851310
026B	GOLD	4822 410 70033	BUTTON OPEN/CLOSE GOLD	318K270130	001T	18A /A,/U		USER GUIDE DV-18MK2 U	402K851250
026B	BLACK	4822 410 70028	BUTTON OPEN/CLOSE BLACK	318K270030	001T	18A /C,/K,/S,/L		USER GUIDE 18MK2 K	402K851350
027B	GOLD	9965 000 00567	BUTTON EPEAT GOLD	376K270120	001Z	17 /N,/S	9965 000 07625	REMOTE CONTROLLER RC-17DV	ZK405K0010
027B	BLACK	9965 000 00566	BUTTON REPEAT BLACK	376K270020	001Z	17 /F		REMOTE CONTROLLER RC-17DV	ZK405K0020
028B	GOLD	9965 000 00565	BUTTON SCAN GOLD	376K270110	001Z	18A		REMOTE CONTROLLER RC7010DV	ZK403K0010
028B	BLACK	9965 000 00564	BUTTON SCAN BLACK	376K270010					
029B		9965 000 00584	LENS STANDBY/FL OFF	351H355010					
035B	GOLD	9965 000 00580	KNOB PHONE GOLD	284T154240					
035B	BLACK	4822 411 20336	KNOB PHONE BLACK	284T154310					
040B	GOLD	9965 000 01554	BADGE MARANTZ GOLD	313J251110					
040B	BLACK	9965 000 01553	BADGE MARANTZ BLACK	313J251010					
045B	GOLD	9965 000 07657	BUTTON POWER GOLD	402K270110					
045B	BLACK	9965 000 07617	BUTTON POWER BLACK	402K270010					
050B	GOLD	9965 000 07658	ESCUTCHEON TRAY LID GOLD	370K063110					
050B	BLACK	9965 000 07618	ESCUTCHEON TRAY LID BLACK	370K063010					
051B	GOLD	9965 000 07659	RETAINER TRAY LID GOLD	402K104110					
051B	BLACK	9965 000 07619	RETAINER TRAY LID BLACK	402K104010					
052B		9965 000 07620	BADGE DVD	370K251110					
002D	17 GOLD	4822 502 14425	SCREW THINHEAD 3X8NI	323S010020					
002D	17 BLACK	4822 502 21693	SCREW THINHEAD 3X8BL	323S010030	001S	17		NOT STANDARD SPARE PARTS PACKING CASE	405K801010
003D	17 GOLD	4822 502 14462	SCREW THINHEAD 3X5NI	318K010020	001S	18A		PACKING CASE DV-18MK2	402K801010
003D	17 BLACK	4822 502 14461	SCREW THINHEAD 3X5BL	318K010030	002S			CUSHION	318K809010
010D	17 GOLD	4822 444 40855	SIDE PANEL GOLD	318K249110					
010D	17 BLACK	4822 444 40854	SIDE PANEL BLACK	318K249010					

1.14 ELECTRICAL PARTS LIST

ASSIGNMENT OF COMMON PARTS CODES.

RESISTORS

R*** : 1) GD05 x x x 140, Carbon film fixed resistor, ±5% 1/4W
 R*** : 2) GD05 x x x 160, Carbon film fixed resistor, ±5% 1/6W
 ① Resistance value

Examples

① Resistance value

0.1Ω 001 10Ω 100 1kΩ 102 100kΩ 104
 0.5Ω 005 18Ω 180 2.7kΩ 272 680kΩ 684
 1Ω 010 100Ω 101 10kΩ 103 1MΩ 105
 6.8Ω 068 390Ω 391 22kΩ 223 4.7MΩ 475

Note : Please distinguish 1/4W from 1/6W by the shape of parts used actually.

CAPACITORS

C*** : CERAMIC CAP.

3) DD1 x x x x 370, Ceramic capacitor
 Disc type
 Temp. coeff. P350~N1000, 50V
 ③ Capacity value
 ② Tolerance

Examples

② Tolerance (Capacity deviation)

±0.25 pF 0
 ±0.5 pF 1
 ±5 % 5

Tolerance of COMMON PARTS handled here are as follows :

0.5 pF - 5 pF ± 0.25 pF
 6 pF - 10 pF ± 0.5 pF
 12 pF - 560 pF ... ± 5 %

③ Capacity value

0.5 pF ... 005 3 pF 030 100 pF 101
 1 pF 010 10 pF 100 220 pF 221
 1.5 pF ... 015 47 pF 470 560 pF 561

C*** : CERAMIC CAP.

4) DK16 x x x 300, High dielectric constant ceramic capacitor
 Disc type
 Temp. chara. 2B4, 50V
 ④ Capacity value

Examples

④ Capacity value

100 pF 101 1000 pF 102 10000 pF 103
 470 pF 471 2200 pF 222

C*** : 5) ELECTROLY CAP. (), 6) FILM CAP ()

5) EA x x x x x 10, Electrolytic capacitor
 One-way lead type, Tolerance ±20%
 ⑥ Working voltage
 ⑤ Capacity value

Examples

⑤ Capacity value

0.1 μF ... 104 4.7 μF ... 475 100 μF 107
 0.33 μF ... 334 10 μF ... 106 330 μF 337
 1 μF ... 105 22 μF ... 226 1100 μF 118
 2200 μF ... 228

⑥ Working voltage

6.3 V 006 25 V 025
 10 V 010 35 V 035
 16 V 016 50 V 050

6) DF15 x x x 350 → Plastic film capacitor
 DF15 x x x 310 → One-way type, Mylar ±5% 50V
 DF16 x x x 310 → Plastic film capacitor
 One-way type, Mylar ±10% 50V

⑦ Capacity value

Examples

⑦ Capacity value

0.001 μF (1000 pF) 102 0.1 μF 104
 0.0018 μF 182 0.56 μF 564
 0.01 μF 103 1 μF 105
 0.015 μF 153

NOTE 1) The above CODES (R***, R***, C***, C*** and C***) are omitted on the schematic diagram in some case.
 2) On the occasion, be confirmed the common parts on the parts list.
 3) Refer to "Common Parts List" for the other common parts (R105, DD4, DK4).

NOTE ON SAFETY FOR FUSIBLE RESISTOR :

The suppliers and their type numbers of fusible resistors are as follows ;

1. KOA Corporation

Part No.(MJI)	Type No.(KOA)	Description
NH05 x x x 140	RF25S x x x x Ω	J ±5% (1/4W)
NH05 x x x 120	RF50S x x x x Ω	J ±5% (1/2W)
NH85 x x x 110	RF73B2A x x x x Ω	J ±5% (1/10W)
NH95 x x x 140	RF73B2E x x x x Ω	J ±5% (1/4W)

* Resistance value

Resistance value(0.1Ω - 10k Ω)

2. Matsushita Electronic Components Co., Ltd

Part No.(MJI)	Type No.(MEC)	Description
NF05 x x x 140	ERD-2FCJ x x x	(±5% 1/4W)
RF05 x x x 140		
NF02 x x x 140	ERD-2FCG x x x	(±2% 1/4W)
RF02 x x x 140		

* Resistance value

Examples



* Resistance value

0.1Ω 001 10Ω 100 1kΩ 102 100kΩ 104
 0.5Ω 005 18Ω 180 2.7kΩ 272 680kΩ 684
 1Ω 010 100Ω 101 10kΩ 103 1MΩ 105
 6.8Ω 068 390Ω 391 22kΩ 223 4.7MΩ 475

ABBREVIATION AND MARKS

ANT. : ANTENNA	BATT. : BATTERY
CAP. : CAPACITOR	CER. : CERAMIC
CONN. : CONNECTING	DIG. : DIGITAL
HP : HEADPHONE	MIC. : MICROPHONE
μ-PRO : MICROPROCESSOR	REC. : RECORDING
RES. : RESISTOR	SPK : SPEAKER
SW : SWITCH	TRANSF. : TRANSFORMER
TRIM. : TRIMMING	TRS. : TRANSISTOR
VAR. : VARIABLE	X' TAL : CRYSTAL

NOTE ON SAFETY:

Symbol  Fire or electrical shock hazard. Only original parts should be used to replaced any part marked with symbol  Any other component substitution (other than original type), may increase risk of fire or electrical shock hazard.

安全上の注意 :

 がついている部品は、安全上重要な部品です。必ず指定されている部品番号の部品を使用して下さい。

POS. NO	VERS. COLOR	PART NO. (PCS)	DESCRIPTION	PART NO. (MJI)
Q815	17/N 7010/N	4822 130 10698	CHIP TRS. 2SA1586(Y GR) 2SA1576(Q R)	HX100012A0
Q816 }	17/N 7010/N	4822 130 60669	CHIP TRS. 2SC4081(Q R) 2SC4116(Y GR)	HX300012A0
Q823 }	17/N 7010/N	4822 130 63601	CHIP TRS. 2SC4213	HX342132A0
Q952 }	17/N 7010/N	4822 130 60669	CHIP TRS. 2SC4081(Q R) 2SC4116(Y GR)	HX300012A0
Q959 }	17/N 7010/N	4822 130 60669	CHIP TRS. 2SC4081(Q R) 2SC4116(Y GR)	HX300012A0
Q960	17/N 7010/N	4822 130 61903	SEMICON.COMP DTA114EUA	BA10026210
Q961	17/N 7010/N	9965 000 04998	PE01-MISCELLANEOUS EMI FILTER NFM41R01C221	FM31221020
Q962	17/N 7010/N	4822 051 30121	CHIP RES. 120Ω ±5% 1/16W	NN05121610
F801	17/N 7010/N	9965 000 04998	EMI FILTER NFM41R01C221	FM31221020
F802	17/N 7010/N	4822 051 30121	CHIP RES. 120Ω ±5% 1/16W	NN05121610
F803 }	17/N 7010/N	9965 000 04998	EMI FILTER NFM41R01C221	FM31221020
F808 }	17/N 7010/N	4822 051 30121	CHIP RES. 120Ω ±5% 1/16W	NN05121610
F809	17/N 7010/N	9965 000 04998	EMI FILTER NFM41R01C221	FM31221020
F810 }	17/N 7010/N	4822 051 30471	CHIP RES. 470Ω ±5% 1/16W	NN05471610
F814 }	17/N 7010/N	4822 051 30471	CHIP RES. 470Ω ±5% 1/16W	NN05471610
F952	17/N 7010/N	4822 051 30121	CHIP RES. 120Ω ±5% 1/16W	NN05121610
F953	17/N 7010/N	4822 051 30121	CHIP RES. 120Ω ±5% 1/16W	NN05121610
F954	17/N 7010/N	4822 051 30121	CHIP RES. 120Ω ±5% 1/16W	NN05121610
F955	17/N 7010/N	4822 051 30121	CHIP RES. 120Ω ±5% 1/16W	NN05121610
F956	17/N 7010/N	4822 051 30471	CHIP RES. 470Ω ±5% 1/16W	NN05471610
F957	17/N 7010/N	4822 051 30471	CHIP RES. 470Ω ±5% 1/16W	NN05471610
F958	17/N 7010/N	4822 051 30121	CHIP RES. 120Ω ±5% 1/16W	NN05121610
F959	17/N 7010/N	4822 051 30121	CHIP RES. 120Ω ±5% 1/16W	NN05121610
J802	17/N 7010/N	9965 000 05000	TERMINAL EUROCONNECTOR	YT02420010
L801 }	17/N 7010/N	4822 157 60445	CHOKE COIL 15μH J%	LC11533900
L804	17/N 7010/N	9965 000 00458	CHOKE COIL 8.2μH EL0405	LC18223900
L805	17/N 7010/N	4822 157 60445	CHOKE COIL 15μH J%	LC11533900
L806	17/N 7010/N	9965 000 00458	CHOKE COIL 8.2μH EL0405	LC18223900
L807	17/N 7010/N	4822 157 60445	CHOKE COIL 15μH J%	LC11533900
L808	17/N 7010/N	9965 000 00458	CHOKE COIL 8.2μH EL0405	LC18223900
L809	17/N 7010/N	4822 157 60445	CHOKE COIL 15μH J%	LC11533900
L810	17/N 7010/N	9965 000 00458	CHOKE COIL 8.2μH EL0405	LC18223900
L811	17/N 7010/N	4822 157 60445	CHOKE COIL 15μH J%	LC11533900
L812	17/N 7010/N	9965 000 00458	CHOKE COIL 8.2μH EL0405	LC18223900
L813	17/N 7010/N	4822 157 60445	CHOKE COIL 15μH J%	LC11533900
L814	17/N 7010/N	9965 000 00458	CHOKE COIL 8.2μH EL0405	LC18223900
L815	17/N 7010/N	4822 157 60445	CHOKE COIL 15μH J%	LC11533900
L816	17/N 7010/N	9965 000 00458	CHOKE COIL 8.2μH EL0405	LC18223900
L951	17/N 7010/N	4822 157 60445	CHOKE COIL 15μH J%	LC11533900

POS. NO	VERS. COLOR	PART NO. (PCS)	DESCRIPTION	PART NO. (MJI)
			PF01-FRONT CIRCUIT BOARD PF01-CAPACITORS	
CF01 }		4822 122 31765	CER. 100pF ±5% 50V	DD95101300
CF11 }		4822 124 23056	ELECT 47μF 10V	EJ47601010
CF12 }		4822 126 11687	CER. 0.1μF +80 -20% 25V	DK98104200
CF13 }		4822 126 11687	CER. 0.1μF +80 -20% 25V	DK98104200
CF14 }		4822 126 11687	CER. 0.1μF +80 -20% 25V	DK98104200
CF15 }		9965 000 01912	CER. 0.047μF +80 -20% 50V	DK98473300
CF16 }		4822 126 11703	CER. 0.01μF +80 -20% 50V	DK98103300
CF19 }		4822 126 11703	CER. 0.01μF +80 -20% 50V	DK98103300
CF20 }		4822 122 31765	CER. 100pF ±5% 50V	DD95101300
CF21 }		4822 122 31765	CER. 100pF ±5% 50V	DD95101300
CF22 }		4822 122 31765	CER. 100pF ±5% 50V	DD95101300
CF28 }		4822 122 31765	CER. 100pF ±5% 50V	DD95101300
CF29 }	17/N 7010/N	4822 122 31765	CER. 100pF ±5% 50V	DD95101300
CF33 }		4822 122 33752	CER. 15pF ±5% 50V	DD95150300
CF34 }		4822 122 33752	CER. 15pF ±5% 50V	DD95150300
CF35 }		9965 000 01912	CER. 0.047μF +80 -20% 50V	DK98473300
CF36 }		4822 126 11687	CER. 0.1μF +80 -20% 25V	DK98104200
CF37 }		4822 124 23056	ELECT 47μF 10V	EJ47601010
CF38 }		4822 126 11687	CER. 0.1μF +80 -20% 25V	DK98104200
CF39 }		4822 122 31765	CER. 100pF ±5% 50V	DD95101300
CF40	17/N 7010/N	4822 122 31765	CER. 100pF ±5% 50V	DD95101300
			PF01-RESISTORS CHIP	
RF01	17/F 18A/L,U		4.7 Ω ±5% 1/16W	NN05047610
RF01	17/S,N	9965 000 03842	18 Ω ±5% 1/16W	NN05180610
RF01	18A		18 Ω ±5% 1/16W	NN05180610
RF01	/A,/C,/K,/S			
RF01	7010	9965 000 03842	18 Ω ±5% 1/16W	NN05180610
RF01	/A,/C,/N,/S			
RF01	7010 /F,/L,/U		4.7 Ω ±5% 1/16W	NN05047610
RF02	17/F		4.7 Ω ±5% 1/16W	NN05047610
RF02	18A/L,U			
RF02	17/S,N	9965 000 03842	18 Ω ±5% 1/16W	NN05180610
RF02	18A		18 Ω ±5% 1/16W	NN05180610
RF02	/A,/C,/K,/S			
RF02	7010	9965 000 03842	18 Ω ±5% 1/16W	NN05180610
RF02	/A,/C,/N,/S			
RF02	7010 /F,/L,/U		4.7 Ω ±5% 1/16W	NN05047610
RF03		4822 117 12925	47k Ω ±5% 1/16W	NN05473610
RF04		4822 051 30102	1k Ω ±5% 1/16W	NN05102610
RF05 }		4822 051 30101	100 Ω ±5% 1/16W	NN05101610
RF10 }		4822 051 30101	100 Ω ±5% 1/16W	NN05101610
RF11 }	17/N 7010/N	4822 051 30101	100 Ω ±5% 1/16W	NN05101610
RF14				
RF15		4822 117 12925	47k Ω ±5% 1/16W	NN05473610
RF16		4822 116 83829	270 Ω ±5% 1/16W	NN05271610
RF17		4822 051 30103	10k Ω ±5% 1/16W	NN05103610
RF18	17 18A	4822 116 83829	270 Ω ±5% 1/16W	NN05271610
RF19 }		4822 051 30103	10k Ω ±5% 1/16W	NN05103610
RF22				
RF23		4822 117 12925	47k Ω ±5% 1/16W	NN05473610
RF24		4822 117 12925	47k Ω ±5% 1/16W	NN05473610
RF26		4822 116 82487	0 Ω ±5% 1/16W	NN05000610
RF27		4822 051 30101	100 Ω ±5% 1/16W	NN05101610
RF28		4822 117 13632	100k Ω ±5% 1/16W	NN05104610
RF29		4822 117 13632	100k Ω ±5% 1/16W	NN05104610
RF30		4822 117 12925	47k Ω ±5% 1/16W	NN05473610
RF31		4822 051 30103	10k Ω ±5% 1/16W	NN05103610

POS. NO	VERS. COLOR	PART NO. (PCS)	DESCRIPTION	PART NO. (MJI)
RK09		4822 051 30151	150 Ω ±5% 1/16W	NN05151610
RK10		4822 051 30151	150 Ω ±5% 1/16W	NN05151610
RK11		4822 051 30222	2.2k Ω ±5% 1/16W	NN05222610
RK12		4822 051 30222	2.2k Ω ±5% 1/16W	NN05222610
RK13		4822 051 30759	75 Ω ±5% 1/16W	NN05750610
RK14		4822 051 30759	75 Ω ±5% 1/16W	NN05750610
RK15		4822 051 30222	2.2k Ω ±5% 1/16W	NN05222610
RK16		4822 051 30222	2.2k Ω ±5% 1/16W	NN05222610
			PK01-SEMICONDUCTORS	
QK01		4822 209 31378	IC NJM4556	HC10045090
QK03				
QK06		4822 130 63601	CHIP TRS. 2SC4213	HX342132A0
			PK01-MISCELLANEOUS	
FK01		4822 157 10416	BLM11B102S 1608 EMIFILTER	FN31010030
FK02		4822 157 10416	BLM11B102S 1608 EMIFILTER	FN31010030
FK03		4822 157 10416	BLM11B102S 1608 EMIFILTER	FN31010030
JK02	17 18A GOLD	4822 267 31692	JACK HLJ0540-01-430 GRAY	YJ01003880
JK02	BLACK	9965 000 01662	JACK HLJ0540-01-410	YJ01003870
			PL01-LED CIRCUIT BOARD	
RF18	7010	4822 051 30222	CHIP RES. 2.2k Ω ±5% 1/16W	NN05222610
DF04	7010	4822 130 11569	L.E.D. HLMF-K200 RED 3MM	HI10005340
			PM01-MAIN CIRCUIT BOARD	
			PM01-CAPACITORS	
CC01	17 /F,/S 18A	4822 124 41539	ELECT 47μF M 16V	OA47601620
CC01	7010 /A,/C,/F /L,/S,/U	4822 124 41539	ELECT 47μF M 16V	OA47601620
CC02	17 /F,/S 18A	4822 126 11703	CER. 0.01μF +80 -20% 50V	DK98103300
CC02	7010 /A,/C,/F /L,/S,/U	4822 126 11703	CER. 0.01μF +80 -20% 50V	DK98103300
CC03	17 /F,/S 18A	4822 126 11703	CER. 0.01μF +80 -20% 50V	DK98103300
CC03	7010 /A,/C,/F /L,/S,/U	4822 126 11703	CER. 0.01μF +80 -20% 50V	DK98103300
CC04	17 /F,/S 18A	4822 126 11703	CER. 0.01μF +80 -20% 50V	DK98103300
CC04	7010 /A,/C,/F /L,/S,/U	4822 126 11703	CER. 0.01μF +80 -20% 50V	DK98103300
CC05	17 /F,/S 18A	4822 124 90371	ELECT 470μF M 10V	OA47701020
CC05	7010 /A,/C,/F /L,/S,/U	4822 124 90371	ELECT 470μF M 10V	OA47701020
CC06	17 /F,/S 18A	4822 126 11703	CER. 0.01μF +80 -20% 50V	DK98103300
CC06	7010 /A,/C,/F /L,/S,/U	4822 126 11703	CER. 0.01μF +80 -20% 50V	DK98103300
CC07	17 /F,/S 18A	4822 124 12389	ELECT 47μF 16V	EQ47601630
CC07	7010 /A,/C,/F /L,/S,/U	4822 124 12389	ELECT 47μF 16V	EQ47601630
CC08	17 /F,/S 18A	9965 000 04997	CER. 5pF ±0.25pF 50V	DD90050300
CC08	17 /N 7010 /N	4822 122 33761	CER. 22pF ±5% 50V	DD95220300
CC08	7010 /A,/C,/F /L,/S,/U	9965 000 04997	CER. 5pF ±0.25pF 50V	DD90050300
CC09	17 /F,/S 18A	4822 124 12389	ELECT 47μF 16V	EQ47601630
CC09	7010 /A,/C,/F /L,/S,/U	4822 124 12389	ELECT 47μF 16V	EQ47601630
CC10	17 /F,/S 18A	4822 126 11703	CER. 0.01μF +80 -20% 50V	DK98103300
CC10	7010 /A,/C,/F /L,/S,/U	4822 126 11703	CER. 0.01μF +80 -20% 50V	DK98103300
CC11	17 /F,/S 18A	4822 124 90353	ELECT 100μF M 10V	OA10701020

POS. NO	VERS. COLOR	PART NO. (PCS)	DESCRIPTION	PART NO. (MJI)
CC11	7010 /A,/C,/F /L,/S,/U	4822 124 90353	ELECT 100μF M 10V	OA10701020
CC12	17 /F,/S 18A	4822 126 11703	CER. 0.01μF +80 -20% 50V	DK98103300
CC12	7010 /A,/C,/F /L,/S,/U	4822 126 11703	CER. 0.01μF +80 -20% 50V	DK98103300
CC13	17 /F,/S 18A	4822 124 90353	ELECT 100μF M 10V	OA10701020
CC13	7010 /A,/C,/F /L,/S,/U	4822 124 90353	ELECT 100μF M 10V	OA10701020
CC14	17 /F,/S 18A		CER. 18pF ±5% 50V	DD95180300
CC14	7010 /A,/C,/F /L,/S,/U		CER. 18pF ±5% 50V	DD95180300
CC15	17 /F,/S 18A	4822 124 12389	ELECT 47μF 16V	EQ47601630
CC15	7010 /A,/C,/F /L,/S,/U	4822 124 12389	ELECT 47μF 16V	EQ47601630
CC16	17 /F,/S 18A		CER. 18pF ±5% 50V	DD95180300
CC16	7010 /A,/C,/F /L,/S,/U		CER. 18pF ±5% 50V	DD95180300
CC17	17 /F,/S 18A	4822 126 11703	CER. 0.01μF +80 -20% 50V	DK98103300
CC17	7010 /A,/C,/F /L,/S,/U	4822 126 11703	CER. 0.01μF +80 -20% 50V	DK98103300
CC18	17 /F,/S 18A	4822 124 90352	ELECT 10μF M 16V	OA10601620
CC18	7010 /A,/C,/F /L,/S,/U	4822 124 90352	ELECT 10μF M 16V	OA10601620
CC19	17 /F,/S 18A	4822 124 80067	ELECT 4.7μF M 50V	OA47505020
CC19	7010 /A,/C,/F /L,/S,/U	4822 124 80067	ELECT 4.7μF M 50V	OA47505020
CD01	17 18A	9965 000 02015	ELECT 22μF M 25V	OA22602540
CD01	7010 /A,/C,/F /N,/S,/U	9965 000 02015	ELECT 22μF M 25V	OA22602540
CD02		4822 124 41539	ELECT 47μF M 16V	OA47601620
CD03		4822 126 11687	CER. 0.1μF +80 -20% 25V	DK98104200
CD04	17 18A	9965 000 02015	ELECT 22μF M 25V	OA22602540
CD04	7010 /A,/C,/F /N,/S,/U	9965 000 02015	ELECT 22μF M 25V	OA22602540
CD05		4822 124 41539	ELECT 47μF M 16V	OA47601620
CD06		4822 126 11687	CER. 0.1μF +80 -20% 25V	DK98104200
CD07		4822 126 11687	CER. 0.1μF +80 -20% 25V	DK98104200
CD08		4822 124 41539	ELECT 47μF M 16V	OA47601620
CD09		4822 126 11687	CER. 0.1μF +80 -20% 25V	DK98104200
CD10		4822 124 41539	ELECT 47μF M 16V	OA47601620
CD18		4822 122 31765	CER. 100pF ±5% 50V	DD95101300
CH01		9965 000 04966	FILM 1200pF 122J 100V	OF15122540
CH02		9965 000 04966	FILM 1200pF 122J 100V	OF15122540
CH03		9965 000 01344	FILM 100pF J 100V	OF15101540
CH04		9965 000 01344	FILM 100pF J 100V	OF15101540
CH05		4822 126 11671	CER. 33pF ±5% 50V	DD95330300
CH06		4822 126 11671	CER. 33pF ±5% 50V	DD95330300
CP01	17 18A	4822 124 40785	ELECT 3300μF M 25V	OA338025S0
CP01	7010	4822 124 21511	ELECT 2200μF 25V	OA22802520
CP02	17 18A	4822 124 40785	ELECT 3300μF M 25V	OA338025S0
CP02	7010	4822 124 21511	ELECT 2200μF 25V	OA22802520
CP03		4822 124 40723	ELECT 2200μF M 16V	OA22801620
CP04		4822 124 90351	ELECT 0.1μF M 50V	OA10405020
CP05		4822 124 90352	ELECT 10μF M 16V	OA10601620
▲ CP06		9965 000 04979	FILM 0.1μF AC250V	DF17104630
▲ CP07		9965 000 04979	FILM 0.1μF AC250V	DF17104630
▲ CP08	18A /A,/C,/K,/S	9965 000 07801	CER. 220pF B 250V	DK17221520
▲ CP08	7010 /A,/C,/N,/S	9965 000 07801	CER. 220pF B 250V	DK17221520
▲ CP08	18A /L,/U		CER. 220pF B 250V	DK17471520
▲ CP09	7010 /F,/L,/U		CER. 220pF B 250V	DK17221520
▲ CP09	18A /A,/C,/K,/S	9965 000 07801	CER. 220pF B 250V	DK17221520
▲ CP09	7010 /A,/C,/N,/S	9965 000 07801	CER. 220pF B 250V	DK17221520

POS. NO	VERS. COLOR	PART NO. (PCS)	DESCRIPTION	PART NO. (MJI)	POS. NO	VERS. COLOR	PART NO. (PCS)	DESCRIPTION	PART NO. (MJI)
▲ DP01 }		9965 000 04986	CHIP DIODE U1BC44 1A/100V	HZ20032050	QC05	7010 /A,/C,/F /L,/S,/U	4822 130 60669	CHIP TRS. 2SC4081(Q R) 2SC4116(Y GR)	HX300012A0
▲ DP04 DP05 }		9965 000 04986	CHIP DIODE U1BC44 1A/100V	HZ20032050	QC06	17 /F,/S 18A	4822 130 60669	CHIP TRS. 2SC4081(Q R) 2SC4116(Y GR)	HX300012A0
DP08 DP09		4822 130 83715	CHIP DIODE 1SS301 DAN202U	HZ21005000	QC06	7010 /A,/C,/F /L,/S,/U	4822 130 60669	CHIP TRS. 2SC4081(Q R) 2SC4116(Y GR)	HX300012A0
DP10		4822 130 83715	CHIP DIODE 1SS301 DAN202U	HZ21005000	QC07	17 /F,/S 18A	4822 130 60669	CHIP TRS. 2SC4081(Q R) 2SC4116(Y GR)	HX300012A0
DP11		9965 000 07632	CHIP DIODE ZENER MA8056-L 5.6V	HZ30007020	QC07	7010 /A,/C,/F /L,/S,/U	4822 130 60669	CHIP TRS. 2SC4081(Q R) 2SC4116(Y GR)	HX300012A0
▲ DP12		4822 130 81248	DIODE S1WB(A)60 30A 600V	HD20031290	QC08	17 /F,/S 18A	4822 130 61903	SEMICON.COMP DTA114EUA	BA10026210
▲ DP13 DP14		4822 130 81244 4822 130 83715	DIODE ERA22-10 CHIP DIODE 1SS301 DAN202U	HD20008130 HZ21005000	QC08	7010 /A,/C,/F /L,/S,/U	4822 130 61903	SEMICON.COMP DTA114EUA	BA10026210
DP15	17 18A /L,/U	4822 130 83715	CHIP DIODE 1SS301 DAN202U	HZ21005000	QC09	17 /F,/S 18A	4822 130 61906	SEMICON.COMP DTC114EU	BA20035210
DP15	7010 /F,/L,/U	4822 130 83715	CHIP DIODE 1SS301 DAN202U	HZ21005000	QC09	7010 /A,/C,/F /L,/S,/U	4822 130 61906	SEMICON.COMP DTC114EU	BA20035210
DP16	17 18A /L,/U	4822 130 83715	CHIP DIODE 1SS301 DAN202U	HZ21005000	QC10	17 /F,/S 18A	4822 130 61906	SEMICON.COMP DTC114EU	BA20035210
DP16	7010 /F,/L,/U	4822 130 83715	CHIP DIODE 1SS301 DAN202U	HZ21005000	QC10	7010 /A,/C,/F /L,/S,/U	4822 130 61906	SEMICON.COMP DTC114EU	BA20035210
▲ DP19		4822 130 82019	CHIP DIODE SBD SFPL-52 200V 0.9A	HZ20002080	QC11	17 /F,/S 18A	4822 130 61906	SEMICON.COMP DTC114EU	BA20035210
▲ DP20		4822 130 82019	CHIP DIODE SBD SFPL-52 200V 0.9A	HZ20002080	QC11	7010 /A,/C,/F /L,/S,/U	4822 130 61906	SEMICON.COMP DTC114EU	BA20035210
▲ DP21 ▲ DP22		9965 000 07633 9965 000 07634	DIODE SBD RK33 30V 2.5A DIODE SBD EK19 90V 1.5A	HD20052080 HD20053080	QC12	17 /F,/S 18A	4822 130 60669	CHIP TRS. 2SC4081(Q R) 2SC4116(Y GR)	HX300012A0
▲ DP23 ▲ DP24		4822 130 11074 4822 130 82019	DIODE SBD RK46 60V 3.5A CHIP DIODE SBD SFPL-52 200V 0.9A	HD20050080 HZ20002080	QC12	7010 /A,/C,/F /L,/S,/U	4822 130 60669	CHIP TRS. 2SC4081(Q R) 2SC4116(Y GR)	HX300012A0
DP25		4822 130 83715	CHIP DIODE 1SS301 DAN202U	HZ21005000	QC13	17 /F,/S 18A	4822 130 61903	SEMICON.COMP DTA114EUA	BA10026210
DP26		9965 000 04986	CHIP DIODE U1BC44 1A/100V	HZ20032050	QC13	7010 /A,/C,/F /L,/S,/U	4822 130 61903	SEMICON.COMP DTA114EUA	BA10026210
DP27		9965 000 07632	CHIP DIODE ZENER MA8056-L 5.6V	HZ30007020	QD01		9965 000 04649	IC PCM1735	HC10014610
DP28		9965 000 03119	CHIP DIODE ZENER MA8033-H 3.3V	HZ30012020	QD02		9965 000 01338	IC TC7SET04F	HC007205K0
DP29		9965 000 04986	CHIP DIODE U1BC44 1A/100V	HZ20032050	QD03		4822 209 90685	IC TC7SH04FU	HC007705K0
DS01 DS02 DS03 DS04 }		9965 000 07629 9965 000 07640 9965 000 07640	CHIP DIODE MA8039-H CHIP DIODE UDZ TE-17 10B CHIP DIODE UDZ TE-17 10B	HZ30025020 HZ30009210 HZ30009210	QH01		4822 130 42839	FET 2SK369 BL VDGS-40V PDO.4W	HF203691B0
DS07		4822 130 83715	CHIP DIODE 1SS301 DAN202U	HZ21005000	QH02		4822 130 42839	FET 2SK369 BL VDGS-40V PDO.4W	HF203691B0
DV01	17 /N 7010 /N	4822 130 83715	CHIP DIODE 1SS301 DAN202U	HZ21005000	QH03		4822 130 61425	CHIP TRS. 2SC2873(Y)	HX328731B0
QC01	17 /F,/S 18A		IC 74HC4053	HC705300Z0	QH04		4822 130 61425	CHIP TRS. 2SC2873(Y)	HX328731B0
QC01	7010 /A,/C,/F /L,/S,/U		IC 74HC4053	HC705300Z0	QH05		4822 130 42839	FET 2SK369 BL VDGS-40V PDO.4W	HF203691B0
QC02	17 /F,/S 18A		IC LA7213	HC10270030	QH06		4822 130 42839	FET 2SK369 BL VDGS-40V PDO.4W	HF203691B0
QC02	7010 /A,/C,/F /L,/S,/U		IC LA7213	HC10270030	QH07 }		4822 130 63928	CHIP TRS. 2SA1312(B)	HX113121B0
QC03	17 /F,/S 18A	9965 000 07641	IC TK15420M	HC10035420	QH12				
QC03	7010 /A,/C,/F /L,/S,/U	9965 000 07641	IC TK15420M	HC10035420	QP01		4822 130 60669	CHIP TRS. 2SC4081(Q R) 2SC4116(Y GR)	HX300012A0
QC04	17 /F,/S 18A	4822 130 61903	SEMICON.COMP DTA114EUA	BA10026210	QP02		4822 130 60669	CHIP TRS. 2SC4081(Q R) 2SC4116(Y GR)	HX300012A0
QC04	7010 /A,/C,/F /L,/S,/U	4822 130 61903	SEMICON.COMP DTA114EUA	BA10026210	QP03		4822 130 60669	CHIP TRS. 2SC4081(Q R) 2SC4116(Y GR)	HX300012A0
QC05	17 /F,/S 18A	4822 130 60669	CHIP TRS. 2SC4081(Q R) 2SC4116(Y GR)	HX300012A0	QP04		4822 130 10698	CHIP TRS. 2SA1586(Y GR) 2SA1576(Q R)	HX100012A0
					QP05		4822 130 63496	SEMICON.COMP RN1311 DTC114TU	BA21311000
					▲ QP06	17 /F 18A /L,/U		IC STR-G6651 SW.REGULATOR	HC10007080
					▲ QP06	7010 /F,/L,/U		IC STR-G6651 SW.REGULATOR	HC10007080

POS. NO	VERS. COLOR	PART NO. (PCS)	DESCRIPTION	PART NO. (MJI)
▲ QP06	17 /S,/N	9965 000 07636	IC STR-G6551 SW.REGULATOR	HC10008080
▲ QP06	18A /A,/C,/K,/S	9965 000 07636	IC STR-G6551 SW.REGULATOR	HC10008080
QP06	7010 /A,/C,/N,/S	9965 000 07636	IC, STR-G6551 POWER IC	HC10008080
QP07	17 /F 18A /L,/U	4822 130 10431	PHOTO UNIT COUPLER PC-123F2	HW10032320
QP07	7010 /F,/L,/U	4822 130 10431	PHOTO UNIT COUPLER PC-123F2	HW10032320
▲ QP08		4822 130 10431	PHOTO UNIT COUPLER PC-123F2	HW10032320
QP09		9965 000 06384	IC TL431CZ	HC33036590
QP10	17 /F 18A /L,/U	4822 130 61906	SEMICON.COMP DTC114EU	BA20035210
QP10	7010 /F,/L,/U	4822 130 61906	SEMICON.COMP DTC114EU	BA20035210
▲ QP11		9965 000 00399	IC SI-3033C +3.3V 1.5A WITH SW	HC36903080
▲ QP12		9965 000 07637	IC PQ2TZ15 +2.5V 1A WITH SW	HC98903320
QP13		4822 130 62548	TRS. 2SB1185(E F)	HT211852B0
QP14		4822 130 61906	SEMICON.COMP DTC114EU	BA20035210
▲ QP15	17 /N 7010 /N	4822 209 80655	IC NJM78M08	HC38508090
▲ QP16		9965 000 04991	IC SI-3050C +5.0V 1.5A WITH SW	HC10006080
QP17		4822 130 62548	TRS. 2SB1185(E F)	HT211852B0
QP18		4822 130 10698	CHIP TRS. 2SA1586(Y GR) 2SA1576(Q R)	HX100012A0
QP22		4822 130 61903	SEMICON.COMP DTA114EUA	BA10026210
QP23		4822 130 62548	TRS. 2SB1185(E F)	HT211852B0
QP24		4822 130 61906	SEMICON.COMP DTC114EU	BA20035210
QS01		4822 130 61906	SEMICON.COMP DTC114EU	BA20035210
QS02		4822 130 61903	SEMICON.COMP DTA114EUA	BA10026210
QS03		4822 130 60669	CHIP TRS. 2SC4081(Q R) 2SC4116(Y GR)	HX300012A0
QS04	17 18A	4822 130 42836	FET 2SK246(GR)	HF202461C0
QS05	17 18A	4822 130 42836	FET 2SK246(GR)	HF202461C0
QS06		4822 130 11604	TRS. 2SB1020	HT21020100
QS07		4822 130 11605	TRS. 2SD1415	HT41415100
QS08		4822 130 61903	SEMICON.COMP DTA114EUA	BA10026210
QS09		4822 130 61903	SEMICON.COMP DTA114EUA	BA10026210
QS11		5322 130 41844	FET 2SK170 V	HF201701H0
QS12		5322 130 41844	FET 2SK170 V	HF201701H0
QS13		4822 130 62649	FET 2SJ74 V	HF100741H0
QS14		4822 130 62649	FET 2SJ74 V	HF100741H0
QS15				
QS18		4822 130 63601	CHIP TRS. 2SC4213	HX342132A0
QS19		4822 209 71373	IC NJM78L05A	HC38105090
QS20		4822 130 61903	SEMICON.COMP DTA114EUA	BA10026210
QS21		4822 130 61903	SEMICON.COMP DTA114EUA	BA10026210
QS52		4822 209 91012	IC 74HCT04AF	HC700405Q0
QV01		4822 130 60669	CHIP TRS. 2SC4081(Q R) 2SC4116(Y GR)	HX300012A0
QV02		4822 130 60669	CHIP TRS. 2SC4081(Q R) 2SC4116(Y GR)	HX300012A0
QV03		4822 130 60669	CHIP TRS. 2SC4081(Q R) 2SC4116(Y GR)	HX300012A0

POS. NO	VERS. COLOR	PART NO. (PCS)	DESCRIPTION	PART NO. (MJI)
QV04		9965 000 07641	IC TK15420M	HC10035420
QV05		9965 000 07641	IC TK15420M	HC10035420
QV06	17 /F,/S 18A	4822 130 61903	SEMICON.COMP DTA114EUA	BA10026210
QV06	7010 /A,/C,/F /L,/S,/U	4822 130 61903	SEMICON.COMP DTA114EUA	BA10026210
QV07		4822 130 60669	CHIP TRS. 2SC4081(Q R) 2SC4116(Y GR)	HX300012A0
QV08	17 /F,/S 18A	4822 130 61903	SEMICON.COMP DTA114EUA	BA10026210
QV08	7010 /A,/C,/F /L,/S,/U	4822 130 61903	SEMICON.COMP DTA114EUA	BA10026210
QV09		4822 130 60669	CHIP TRS. 2SC4081(Q R) 2SC4116(Y GR)	HX300012A0
QV10		4822 130 10698	CHIP TRS. 2SA1586(Y GR) 2SA1576(Q R)	HX100012A0
QV11		4822 130 10698	CHIP TRS. 2SA1586(Y GR) 2SA1576(Q R)	HX100012A0
QV12		4822 130 10698	CHIP TRS. 2SA1586(Y GR) 2SA1576(Q R)	HX100012A0
QV13		4822 130 61906	SEMICON.COMP DTC114EU	BA20035210
QV14		4822 130 61903	SEMICON.COMP DTA114EUA	BA10026210
QV15		4822 130 61906	SEMICON.COMP DTC114EU	BA20035210
QV16		4822 130 61903	SEMICON.COMP DTA114EUA	BA10026210
QV17		4822 130 60669	CHIP TRS. 2SC4081(Q R) 2SC4116(Y GR)	HX300012A0
QV18		4822 130 60669	CHIP TRS. 2SC4081(Q R) 2SC4116(Y GR)	HX300012A0
QV50		9965 000 07642	IC TC74VHCT125AF	HC712505Q0
QV51		9965 000 07643	IC TC74VHC125F	HC007605K0
PM01-MISCELLANEOUS				
FC01	17 /F,/S 18A	9965 000 04998	EMI FILTER NFM41R01C221	FM31221020
FC01	7010 /A,/C,/F /L,/S,/U	9965 000 04998	EMI FILTER NFM41R01C221	FM31221020
FC02	17 /F,/S 18A	9965 000 04998	EMI FILTER NFM41R01C221	FM31221020
FC02	7010 /A,/C,/F /L,/S,/U	9965 000 04998	EMI FILTER NFM41R01C221	FM31221020
FC03	17 /F,/S 18A	9965 000 04998	EMI FILTER NFM41R01C221	FM31221020
FC03	7010 /A,/C,/F /L,/S,/U	9965 000 04998	EMI FILTER NFM41R01C221	FM31221020
▲ FP02		4822 071 52501	FUSE T250MA/250V TR5 NO.19372	FS20025200
▲ FP03		4822 071 55001	FUSE T500MA/250V TR5 NO.19372	FS20050200
▲ FP04		4822 071 51602	FUSE T1.6A/250V TR5 NO.19372	FS20160200
▲ FP05		4822 071 52501	FUSE T250MA/250V TR5 NO.19372	FS20025200
▲ FP06		4822 071 52501	FUSE T250MA/250V TR5 NO.19372	FS20025200
▲ FP07		4822 071 51252	FUSE T1.25A/250V TR5 NO.19372	FS20125200
▲ FP08		4822 071 55001	FUSE T500MA/250V TR5 NO.19372	FS20050200
▲ FP09		4822 071 55001	FUSE T500MA/250V TR5 NO.19372	FS20050200
FS01				
FS06		4822 157 10416	BLM11B102S 1608 EMIFILTER	FN31010030

POS. NO	VERS. COLOR	PART NO. (PCS)	DESCRIPTION	PART NO. (MJI)	POS. NO	VERS. COLOR	PART NO. (PCS)	DESCRIPTION	PART NO. (MJI)
FV01 S FV04		9965 000 04998	EMI FILTER NFM41R01C221	FM31221020	▲ TP02	7010 /A,/C,/N,/S	9965 000 07639	POWER TRANSF., SW. AC230V	TS12918020
JC01	17 /F,/S 18A		TERMINAL RCA JACK 3P YKC21-4010	YT02030580	▲ TP02	18A,/L,/U		MAINS TRANSF. SW.	TS12918010
JC01	17 /F,/S 18A		TERMINAL RCA JACK 3P YKC21-4010	YT02030580				PS01-POWER SWITCH CIRCUIT BOARD	
JC01	7010 /A,/C,/F /L,/S,/U		TERMINAL RCA JACK 3P YKC21-4010	YT02030580	FE01	18A 7010		PS01-MISCELLANEOUS FERRITE CORE	FC50150010
▲ JP05	17 18A		PLUG CONNECTOR 2P B3P-VH	YP04000760	▲ FP01	17 /F 18A /L,/U		TFC-23-11-14 TFP2014-V FUSE 1.25A 125V	FS10125350
JP06	18A		JACK 1MM PITCH FFC 30 FMN-BTK(ST)	YJ07022240	▲ FP01	7010 /F,/L,/U		UL CSA MINI FBT FUSE 1.25A 125V	FS10125350
JP07	18A		JACK 1MM PITCH FFC 16 FMN-BTK(ST)	YJ07022220	▲ FP01	17 /S,/N	4822 070 31252	FUSE 1.25A 250V BS LISTED	FS10125850
JP08	7010		GND TERMINAL FOR PCB	YL01010240	▲ FP01	18A /A,/C,/K,/S	4822 070 31252	FUSE 1.25A 250V BS LISTED	FS10125850
JS01		4822 290 81723	TERMINAL RCA JACK 4P WHITE/RED	YT02041070	▲ FP01	7010 /A,/C,/N,/S	4822 070 31252	FUSE 1.25A 250V BS LISTED	FS10125850
JS02		4822 290 81638	TERMINAL RCA JACK 1P BLACK	YT02010790	▲ JP01	17 /N 7010 /S,/U		PLUG CONNECTOR 2P B3P-VH	YP04000760
JS03		4822 130 10845	OPT. CONNECTOR GP1F32T OUTPUT	YJ15000090	▲ JP02		9965 000 04864	JACK CLIP FOR 20MM FUSE ON PCB	YJ08000580
JS04		4822 267 41009	TERMINAL RCA JACK 2P BLACK	YT02020890	▲ JP03		9965 000 04865	JACK CLIP FOR 20MM FUSE ON PCB	YJ08000590
JS07	7010		M1698 PWB GND TERMINAL WITH M3	YL01010140	▲ JP04			PLUG CONNECTOR 2P B3P-VH	YP04000760
JV01	17 18A		JACK 1MM PITCH FFC 30 FMN-BTK(ST)	YJ07022240	▲ JP10	18A /S		TERMINAL FOR AC COAD ON PCB	YL01010250
JV03		9965 000 05008	TERMINAL RCA JACK 2P YELLOW	YT02021590	▲ SP01		4822 276 13364	PUSH SWITCH SDDL1 MAINS TV-3	SP01011990
JV04		4822 265 10678	TERMINAL S-VIDEO JACK 1P	YT02011010				PV01-SYSTEM SWITCH CIRCUIT BOARD	
JV06 JV08	18A 7010		JACK 07FMN-BTK M1698 PWB GND TERMINAL WITH M3	YJ07022210 YL01010140				PV01-CAPACITORS CER. 18pF ±5% 50V	DD95180300
▲ LP02		4822 157 70398	CHOKE COIL LF-4D-223 22μH 0.4A	LC22260130	CV21	7010 /A,/C,/F,/L,/S		CER. 47pF ±5% 50V	DD95470300
LP03	17 /N 7010 /N	4822 157 60445	CHOKE COIL 15μH J	LC11533900	CV22	7010 /A,/C,/F,/L,/S	4822 122 33777	CER. 5pF ±0.25pF 50V	DD90050300
LP04	17 /N 7010 /N	4822 157 60445	CHOKE COIL 15μH J	LC11533900	CV34	7010 /A,/C,/F,/L,/S	9965 000 04997	CER. 5pF ±0.25pF 50V	DD90050300
LP05		9965 000 07635	CHOKE COIL 22μH 1.29A	LC22230060	CV36	7010 /A,/C,/F,/L,/S	9965 000 04997	CER. 5pF ±0.25pF 50V	DD90050300
LS01		4822 142 60422	PULSE TRANSF.	TP41042030	CV47	7010 /A,/C,/F,/L,/S	9965 000 04997	CER. 5pF ±0.25pF 50V	DD90050300
LS02		9965 000 00458	CHOKE COIL 8.2μH EL0405	LC18223900				PV01-RESISTORS CHIP 4.7k Ω ±5% 1/16W	NN05472610
LS03		9965 000 00458	CHOKE COIL 8.2μH EL0405	LC18223900	RV84	17 /S,/N	4822 051 30472	4.7k Ω ±5% 1/16W	NN05472610
LV01		4822 157 60445	CHOKE COIL 15μH J	LC11533900	RV84	18A	4822 051 30472	4.7k Ω ±5% 1/16W	NN05472610
LV02		4822 157 60445	CHOKE COIL 15μH J	LC11533900	RV84	7010 /A,/C,/K,/S,/L	4822 051 30472	4.7k Ω ±5% 1/16W	NN05472610
LV03		4822 157 60445	CHOKE COIL 15μH J	LC11533900				PV01-MISCELLANEOUS JACK S5B-PH-K-S	YJ06006450
LV04		9965 000 00458	CHOKE COIL 8.2μH EL0405	LC18223900	SV01		4822 277 11818	SLIDE SWITCH SSSB02	SS02021440
LV05		4822 157 60445	CHOKE COIL 15μH J	LC11533900	SV02	17 /F,/S 18A	4822 277 11818	SLIDE SWITCH SSSB02	SS02021440
LV06		9965 000 00458	CHOKE COIL 8.2μH EL0405	LC18223900	SV02	7010 /A,/C,/F /L,/S,/U	4822 277 11818	SLIDE SWITCH SSSB02	SS02021440
LV07		4822 157 60445	CHOKE COIL 15μH J	LC11533900	SV03	17 /S,/N	9965 000 07644	SLIDE SWITCH SSSB023-P06S	SS02030790
LV08		9965 000 00458	CHOKE COIL 8.2μH EL0405	LC18223900	SV03	18A /A,/C,/K,/S,/L	9965 000 07644	SLIDE SWITCH SSSB023-P06S	SS02030790
LV09		4822 157 60445	CHOKE COIL 15μH J	LC11533900	SV03	7010 /A,/C,/F /L,/S,/U	9965 000 07644	SLIDE SWITCH SSSB023-P06	SS02030790
▲ TP01	17 /F 7010 /F		MAINS TRANSF. AC100V	TS14156020	JV09	18A			
▲ TP01	17 /S,/N	9965 000 07638	MAINS TRANSF. AC230V	TS14156030					
▲ TP01	18A	9965 000 07638	MAINS TRANSF. AC230V	TS14156030					
▲ TP01	/A,/C,/K,/S 7010	9965 000 07638	POWER TRANSF. AC230V	TS14156030					
▲ TP01	/A,/C,/N,/S 18A,/L,/U 7010 /L,/U		MAINS TRANSF. AC120V	TS14156010					
▲ TP02	17 /F 7010 /F,/L,/U		MAINS TRANSF. SW. AC100V	TS12918010					
▲ TP02	17 /S,/N	9965 000 07639	MAINS TRANSF. SW. AC230V	TS12918020					
▲ TP02	18A /A,/C,/K,/S	9965 000 07639	MAINS TRANSF. SW. AC230V	TS12918020					

Service Manual

DB-VLD210

DVD Loader for MARANTZ

DVD Player : DV7010

DV7100

DV-18mkII

DV-17

EC1000

ER3000



TABLE OF CONTENTS

SECTION	PAGE
2.DB-VLD 210 (DVD Loader for MARANTZ)	
2.1 EXTERIOR	2-1
2.2 LOADING MECHANISM ASSY	2-2
2.3 TRAVERSE MECHANISM ASSYS	2-3

Please use this service manual with referring to the user guide (D.F.U) without fail.
修理の際は、必ず取り扱い説明書を準備し操作方法を確認の上作業を行ってください。

marantz®

DB-VLD210

2.1 EXTERIOR

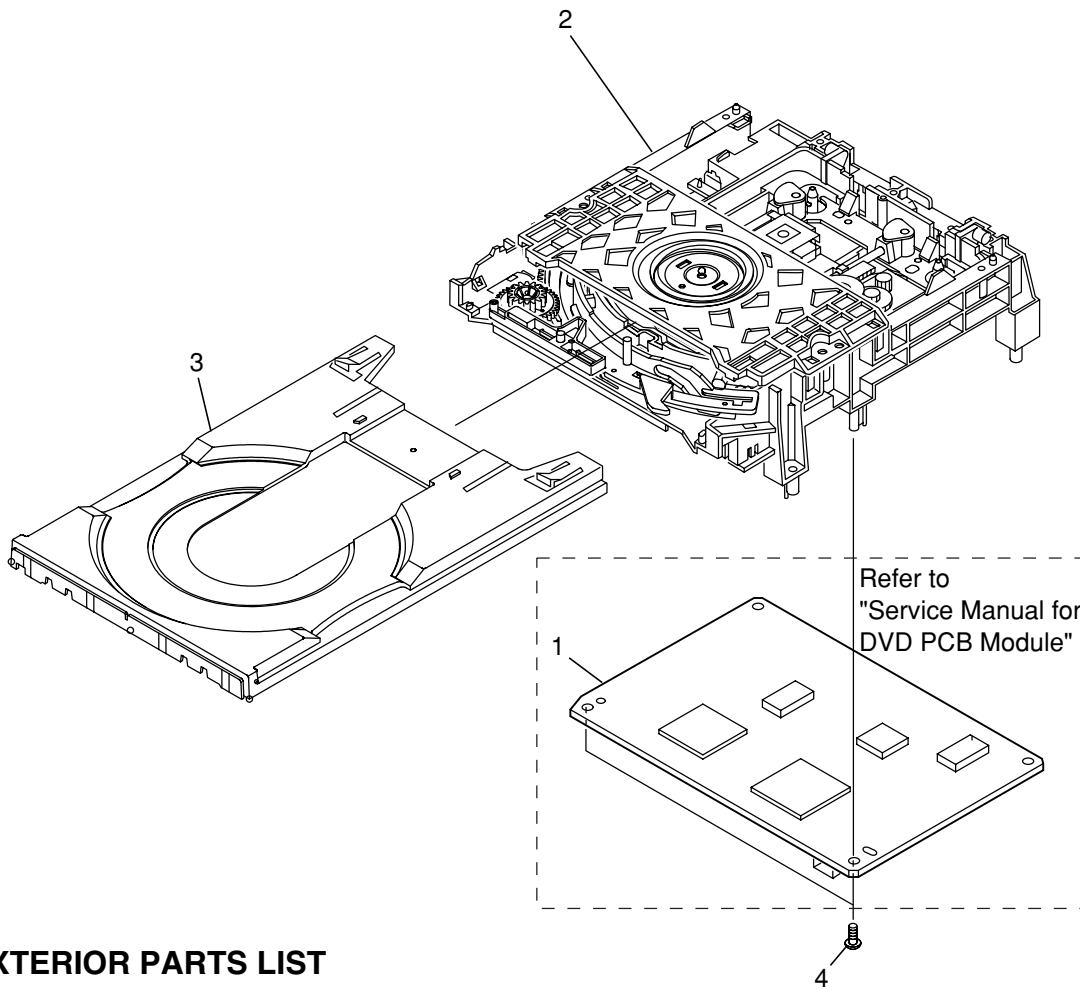

(1) EXTERIOR PARTS LIST

Mark	No.	Part No. (for PCS)	Description	Part No. (for MJ)
	1	—	VWS1446, DVDM Assy DB-VPB210	ZK402K0210
	1	—	VWS1449, DVDM Assy DB-VPB211	ZK324J0210
	1	9965 000 07628	VWS1447, DVDM Assy DB-VPB212	ZK402K0230
	1	—	VWS1448, DVDM Assy DB-VPB213	ZK402K0220
	1	—	VWS1450, DVDM Assy DB-VPB214	ZK324J0220
	1	—	VWS1451, DVDM Assy DB-VPB215	ZK408K0210
NSP	2	—	VWT1174, Loader Assy	—
	3	9965 000 07934	VNL1858, Tray	402K163210
NSP	4	—	PPZ30P080FMC, Screw	—

● DISASSEMBLY OF TRAVERSE MECHANISM ASSY

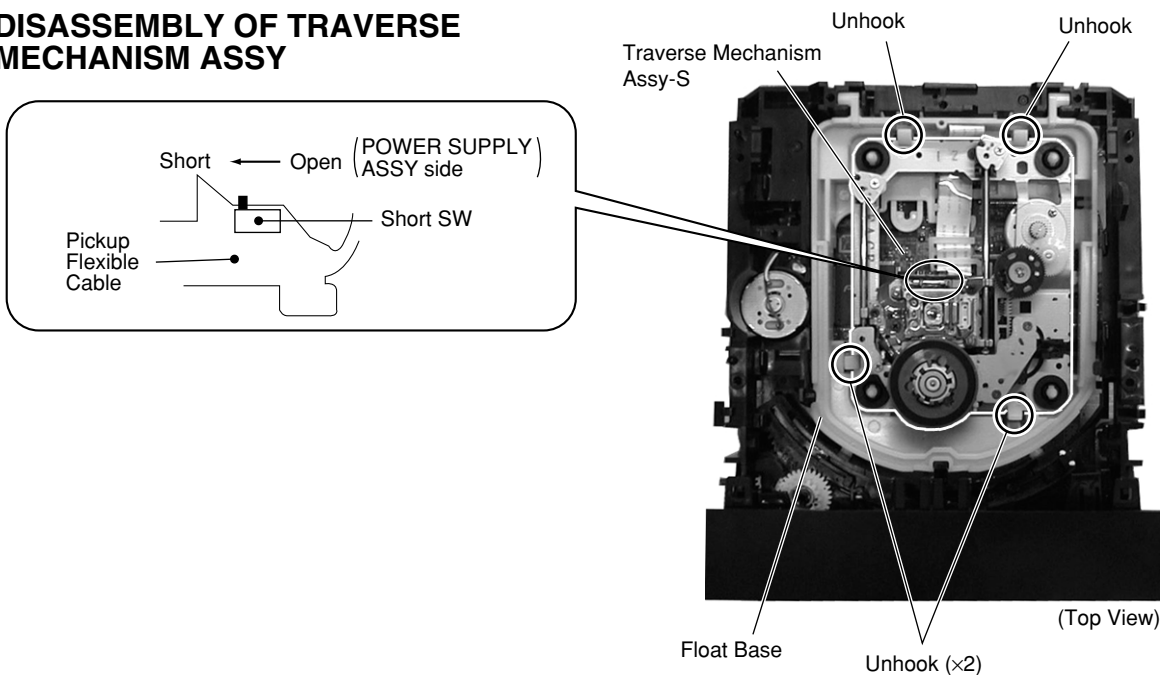

2.2 LOADING MECHANISM ASSY

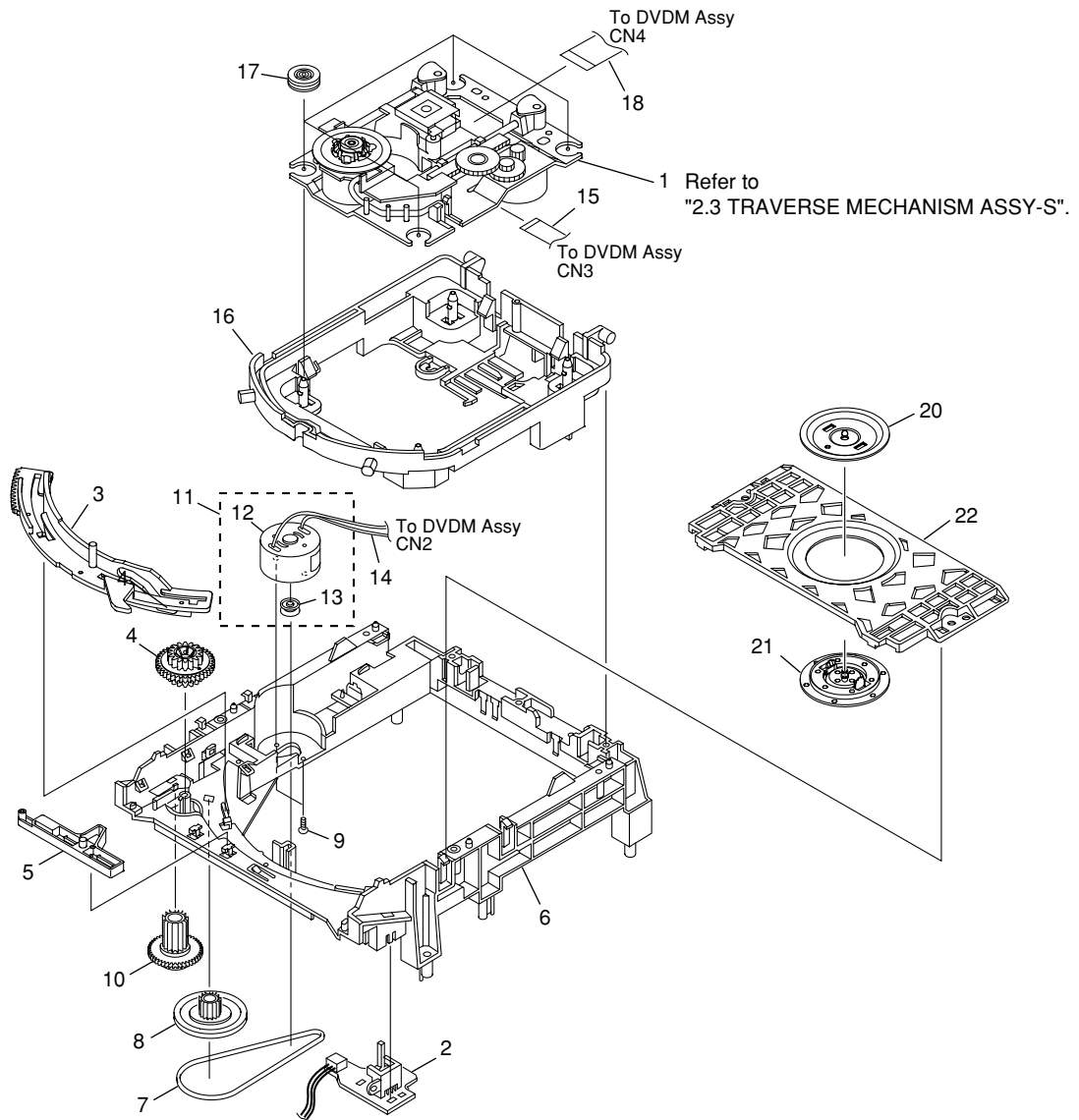

● LOADING MECHANISM ASSY PARTS LIST

Mark	No.	Part No. (for PCS)	Description	Part No. (for MJ)
NSP	1	9965 000 07935	VXX2653, Traverse Mechanism Assy-S	*ZK000310R
	2	—	VWG2171, LOAB Assy	—
	3	9965 000 07936	VNL1862, Drive Cam	402K054210
NSP	4	9965 000 07937	VNL1861, Drive Gear	402K058210
	5	9965 000 07938	VNL1820, Lock Plate	402K104210
	6	—	PNW2968, Loading Bases	—
NSP	7	9965 000 07939	VEB1315, Belt	402K264210
	8	9965 000 07940	VNL1866, Gear Pulley	402K262210
	9	—	JGZ17P028FMC, Screw	—
NSP	10	9965 000 07941	VNL1860, Loading Gear	402K058220
	11	9965 000 07942	VXX2505, Loading Motor Assy	*ZZ001600R

Mark	No.	Part No. (for PCS)	Description	Part No. (for MJ)
NSP	12	—	PXM1027, DC Motor / 0.3W (LOADING)	—
NSP	13	—	PNW1634, Motor Pulley	296W262010
	14	—	VKP2253, Connector Assy	—
NSP	15	9965 000 07943	VDA1842, Flexible Cable (08P)	*YU000790R
	16	9965 000 07944	VNL1865, Float Base	402K105210
	17	9965 000 07945	VEB1286, Floating Rubber	402K056210
	18	9965 000 07946	VDA1843, Flexible Cable (24P)	*YU000800R
	20	9965 000 07947	VNE2162, Clamper Plate	402K104220
	21	9965 000 07948	VNL1738, Clamper	402K005210
	22	9965 000 07949	VNL1859, Bridge	402K104230

2.3 TRAVERSE MECHANISM ASSY-S

• Top View

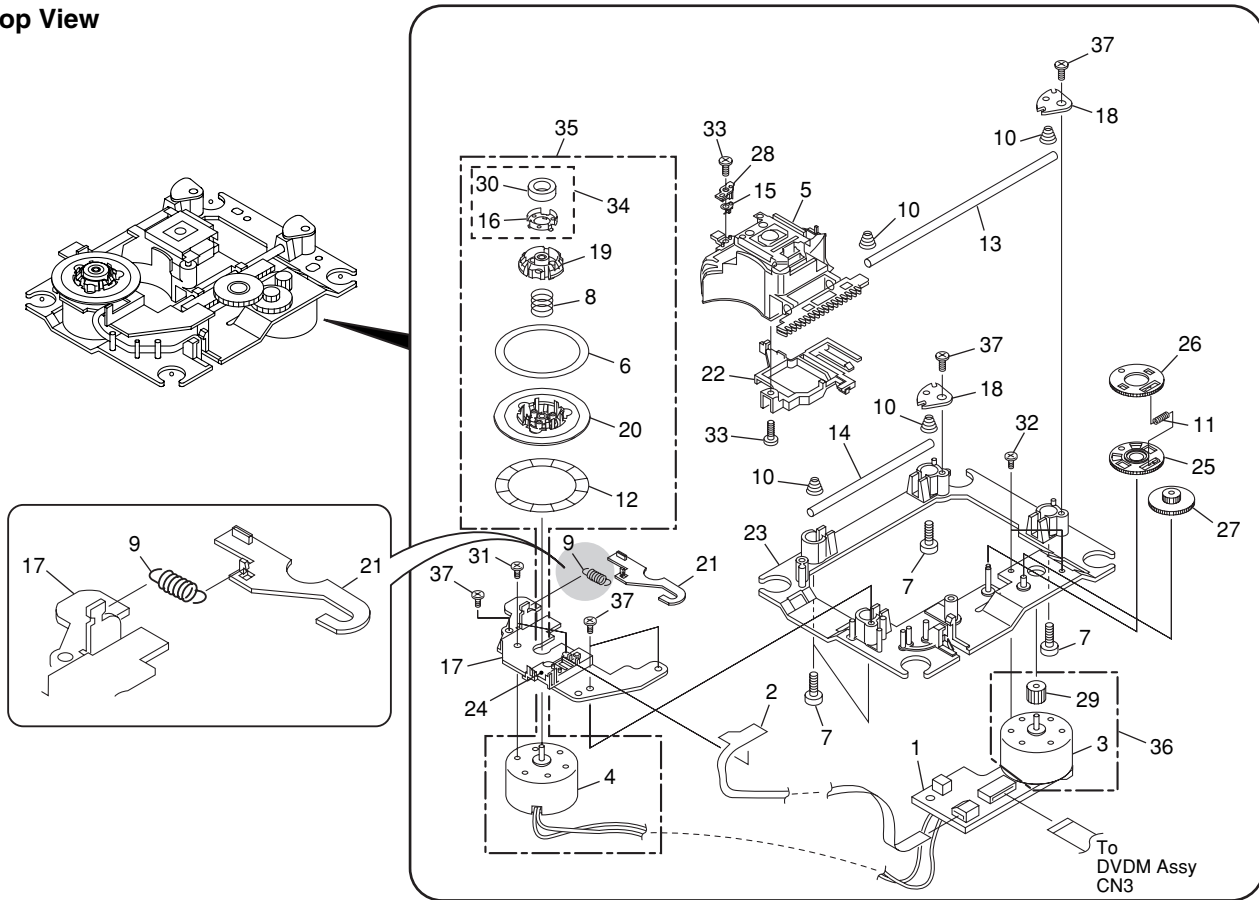

• TRAVERSE MECHANISM ASSY-S PARTS LIST

Mark	No.	Part No. (for PCS)	Description	Part No. (for MJ)
NSP	1	—	VWG2048, SMEB Assy	—
NSP	2	—	VWG2009, FGSB Assy	—
NSP	3	—	VXM1079, Motor	—
NSP	4	—	VXM1084, Motor	—
△NSP	5	—	VWY1055, Pickup Assy	—
NSP	6	—	DEC2040, Table Sheet	—
NSP	7	—	VBA1058, Screw	—
NSP	8	—	VBH1278, Centering Spring	—
	9	9965 000 07950	VBH1317, Hook Spring	296W115050
	10	9965 000 07951	VBH1303, Skew Spring	296W115060
	11	9965 000 07952	VBH1308, Gear Spring	296W115070
NSP	12	—	VEC1959, Reflected Sheet	—
NSP	13	—	VLL1504, Guide Bar	—
NSP	14	—	VLL1505, Sub-guide Bar	—
	15	9965 000 07953	VNC1017, Hold Spring	296W115080
NSP	16	—	VNE2070, Magnet Holder	—
NSP	17	—	VNE2154, Motor Base	—
NSP	18	—	VNE2155, Cover	—
NSP	19	—	VNL1746, Centering Ring	—

Mark	No.	Part No. (for PCS)	Description	Part No. (for MJ)
NSP	20	—	VNL1747, Disc Table	—
	21	9965 000 07954	VNL1770, Hook	296W258010
NSP	22	—	VNL1802, FFC Holder	—
NSP	23	—	VNL1806, Mechanism Base	—
NSP	24	—	VNL1807, FG Holder	—
	25	9965 000 07955	VNL1808, Gear A	296W058090
	26	9965 000 07956	VNL1809, Gear B	296W058100
	27	9965 000 07957	VNL1810, Gear C	296W058110
	28	9965 000 07958	VNL1811, Slider	296W125010
NSP	29	—	VNL1814, Gear D	—
NSP	30	—	VYM1024, Magnet	—
NSP	31	—	JFZ17P025FZK, Screw	—
NSP	32	—	JGZ17P028FMC, Screw	—
NSP	33	—	VBA1051, Screw	—
NSP	34	—	VXX2507, Magnet Holder Assy	—
	35	9965 000 07959	VXX2649, Spindle Motor Assy	*ZK000290R
	36	9965 000 07960	VXX2650, Carriage Motor Assy	*ZK000300R
NSP	37	—	PBA1069, Screw	—

Service Manual

DB-VPB210, DB-VPB211, DB-VPB212, DB-VPB213, DB-VPB214 DVD PCB Module for MARANTZ

DVD Player : DV7010
DV-18mkII
DV-17
EC1000
ER3000

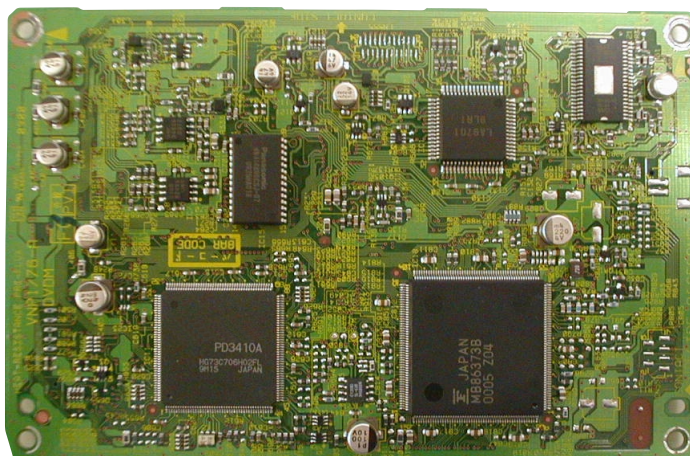

The DVD module is different with each product and version.
Refer to the following table.

Model	Vers.		
	/U, /F, /A	/K, /L, /S, /C	/N
DV7010	DB-VPB210	DB-VPB213	DB-VPB212
DV-18mkII	DB-VPB210	DB-VPB213	
DV-17	DB-VPB210	DB-VPB213	DB-VPB212

Model	Vers.		
	/F, /A, /S, /C	/K, /L	/N
EC1000	DB-VPB211	DB-VPB214	
ER3000	DB-VPB211	DB-VPB214	(DB-VPB217)

TABLE OF CONTENTS

SECTION	PAGE
3. DB-VPB210 / 211 / 212 / 213 / 214 (DVD PCB Module for MARANTZ)	
3.1 BLOCK DIAGRAM AND SCHEMATIC DIAGRAM	3-1
3.2 PCB CONNECTION DIAGRAM	3-10
3.3 PCB PARTS LIST	3-24

Please use this service manual with referring to the user guide (D.F.U) without fail.
修理の際は、必ず取り扱い説明書を準備し操作方法を確認の上作業を行ってください。

marantz®

DB-VPB210/211/212/213/214

3.1 BLOCK DIAGRAM AND SCHEMATIC DIAGRAM

3.1.1 BLOCK DIAGRAM

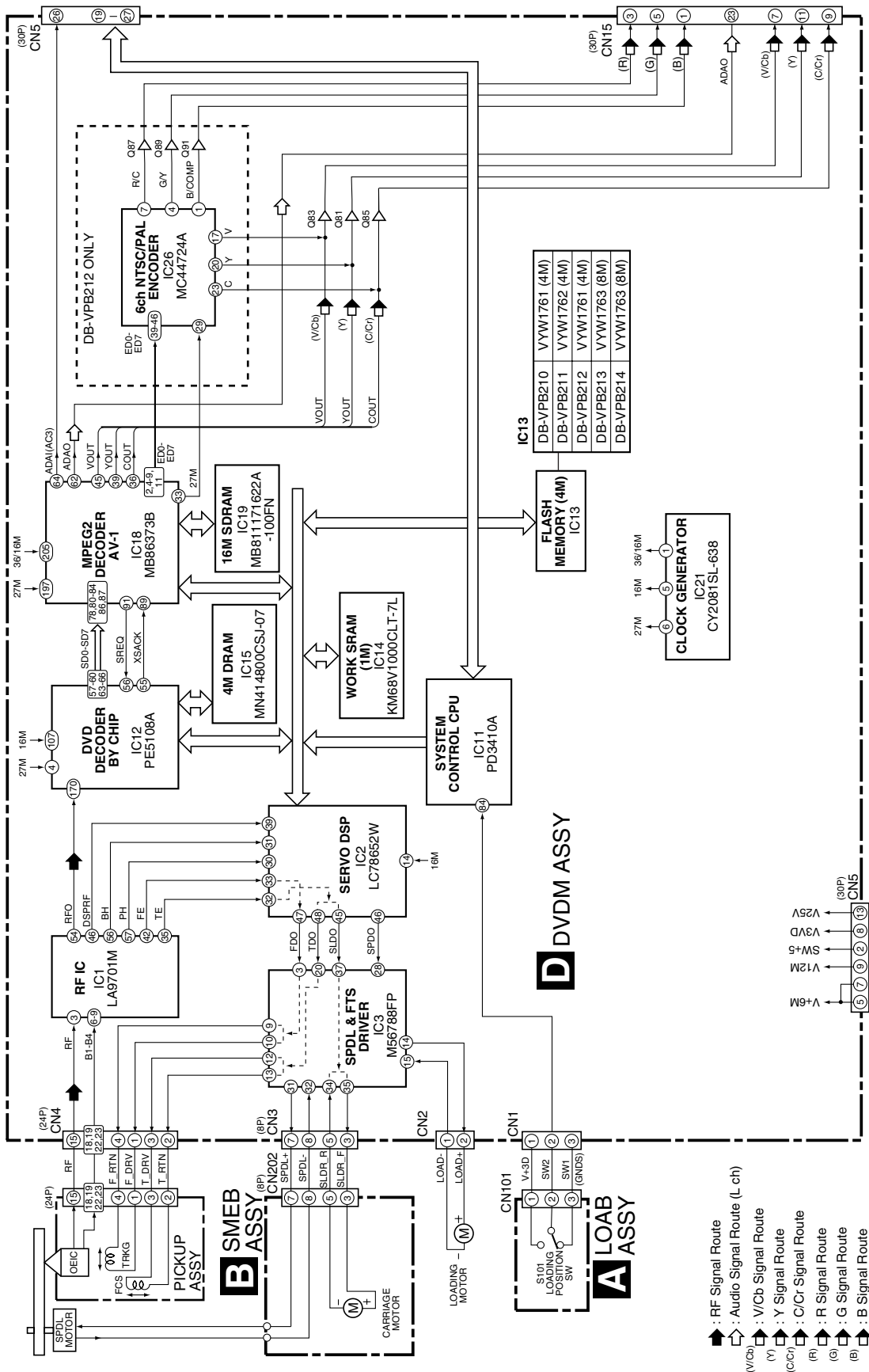

3.1.2 LOAB, SMEB, FGSB ASSYS and OVERALL WIRING DIAGRAM

- ➡ : RF SIGNAL ROUTE
- (F) : FOCUS SERVO LOOP LINE
- (T) : TRACKING SERVO LOOP LINE
- (S) : SLIDER SERVO LOOP LINE

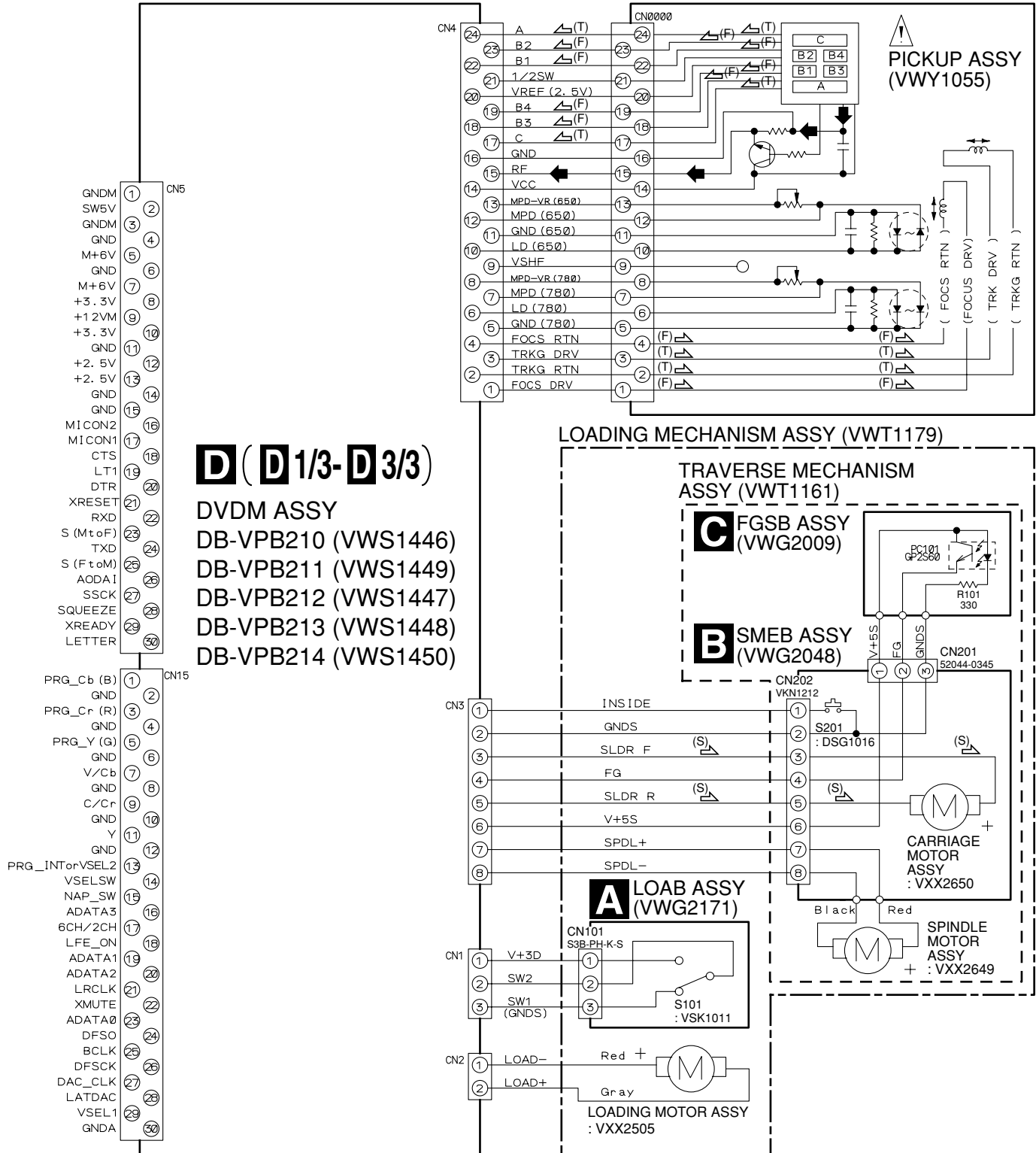

3.1.3 DVDM ASSY (1/3)

D 1/3 DVDM ASSY

(VWS1446, VWS1449, VWS1447, VWS1448 VWS1450)

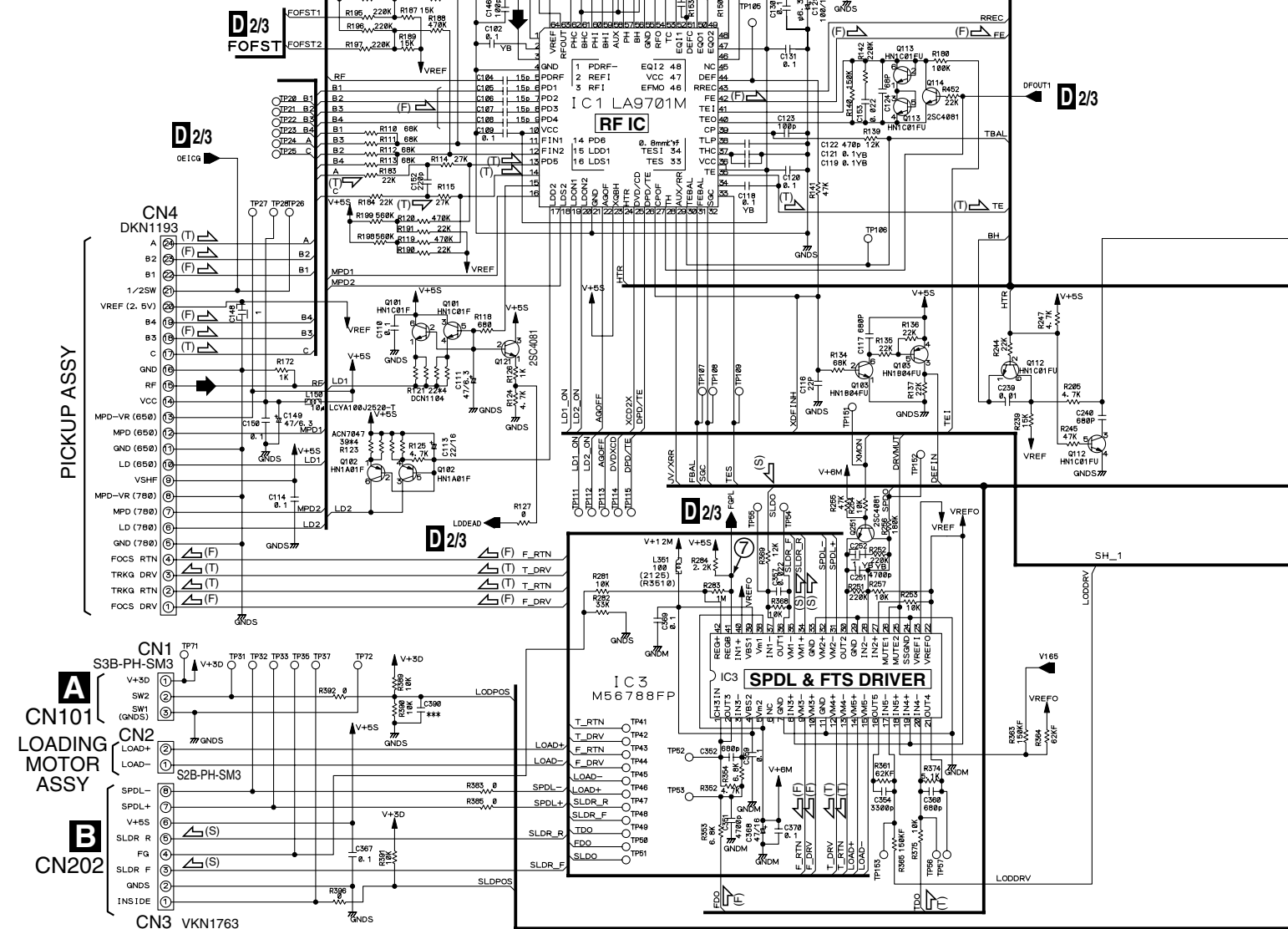
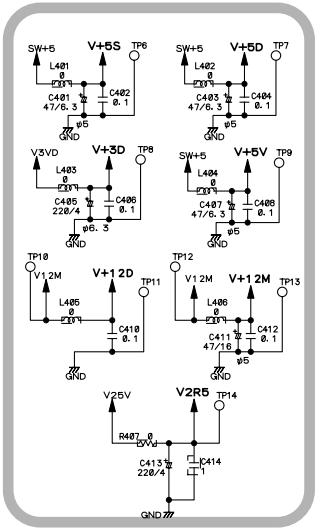

 : The power supply is shown with the marked box.

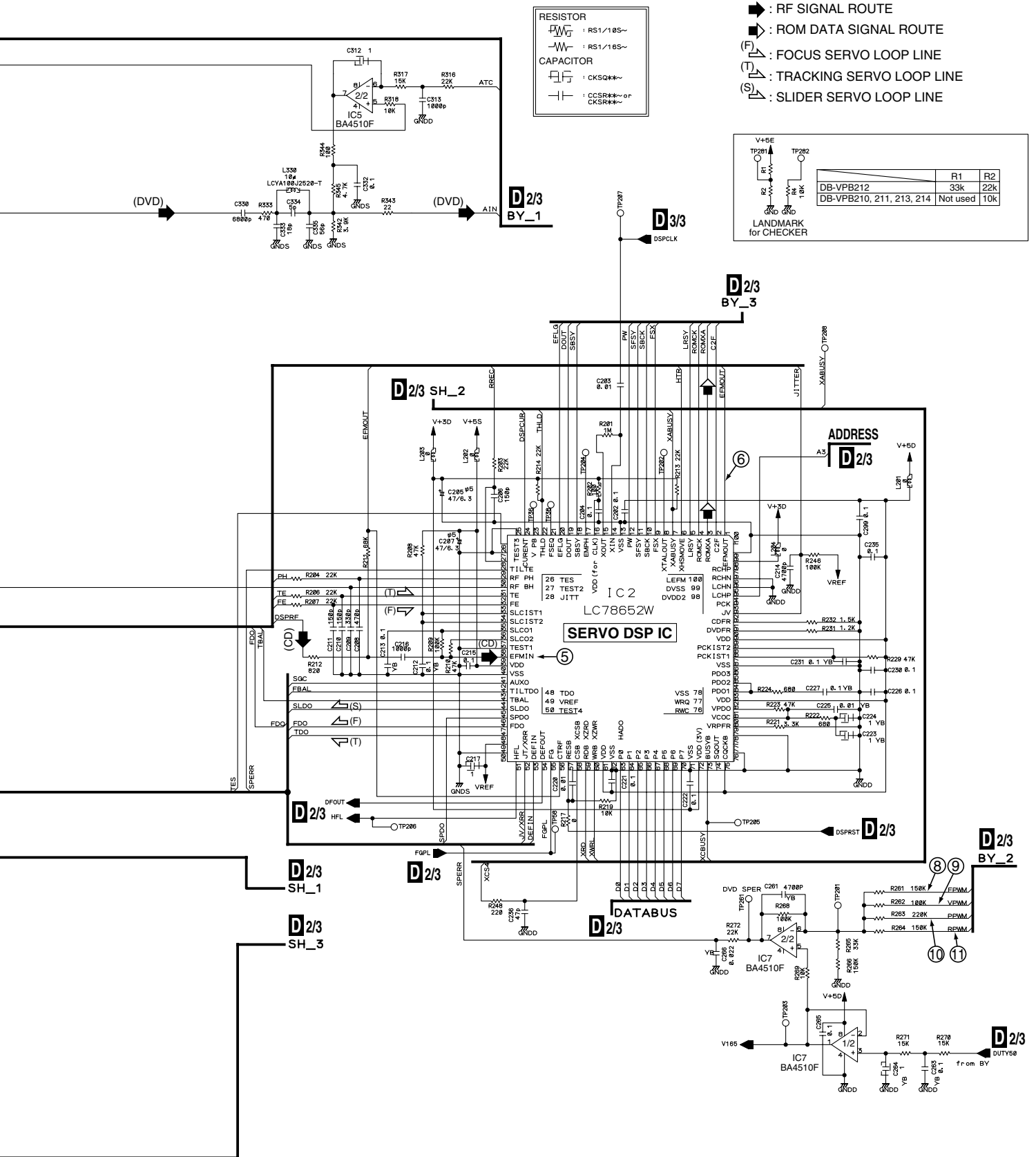

3.1.4 DVDM ASSY (2/3)

D 2/3 DVDM ASSY (VWS1446, VWS1449, VWS1447, VWS1448, VWS1450)

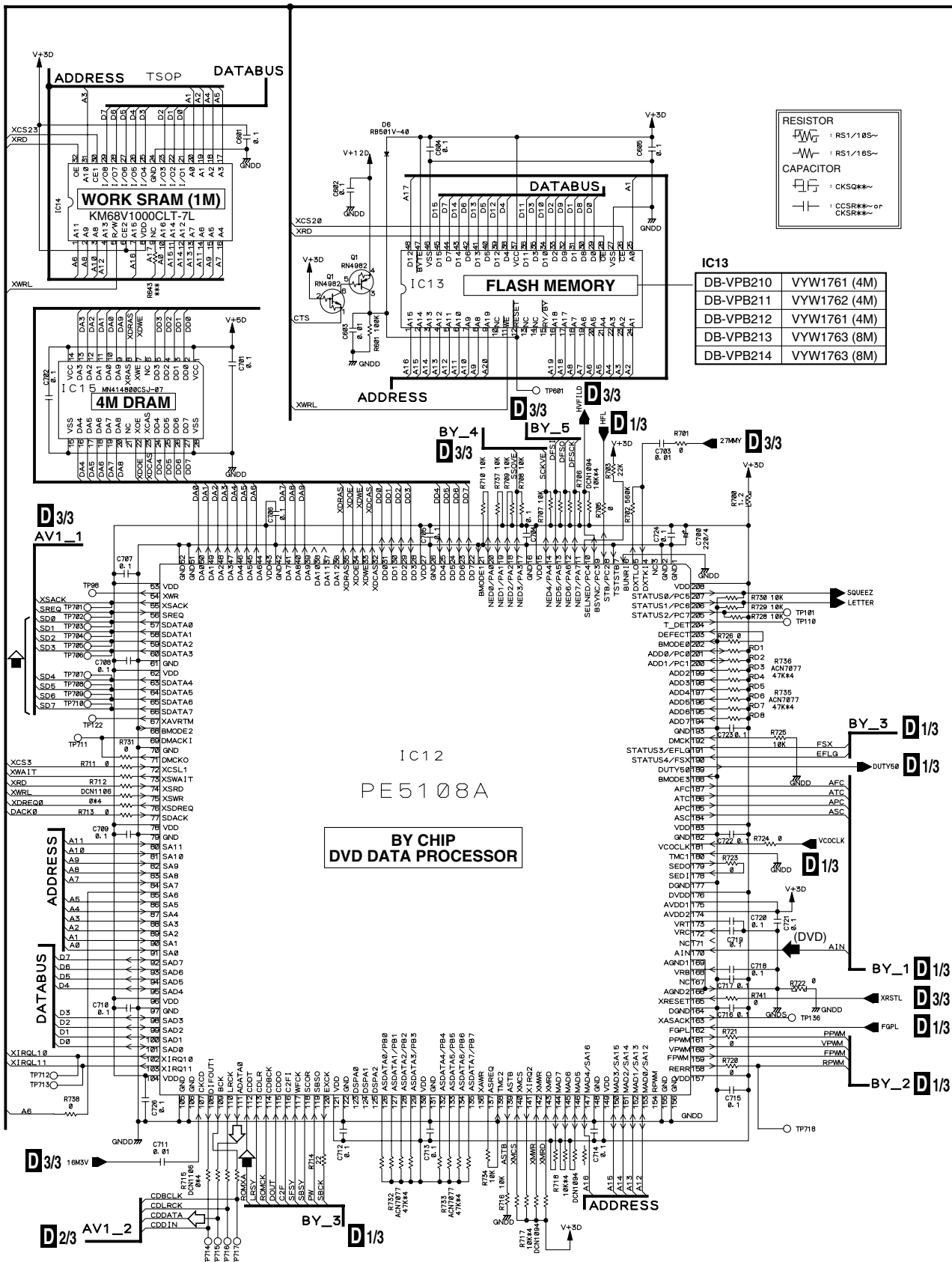

D 1/3, 3/3 : The power supply is shown with the marked box.

- : RF SIGNAL ROUTE
- : ROM DATA SIGNAL ROUTE
- ⬅ : AUDIO SIGNAL ROUTE

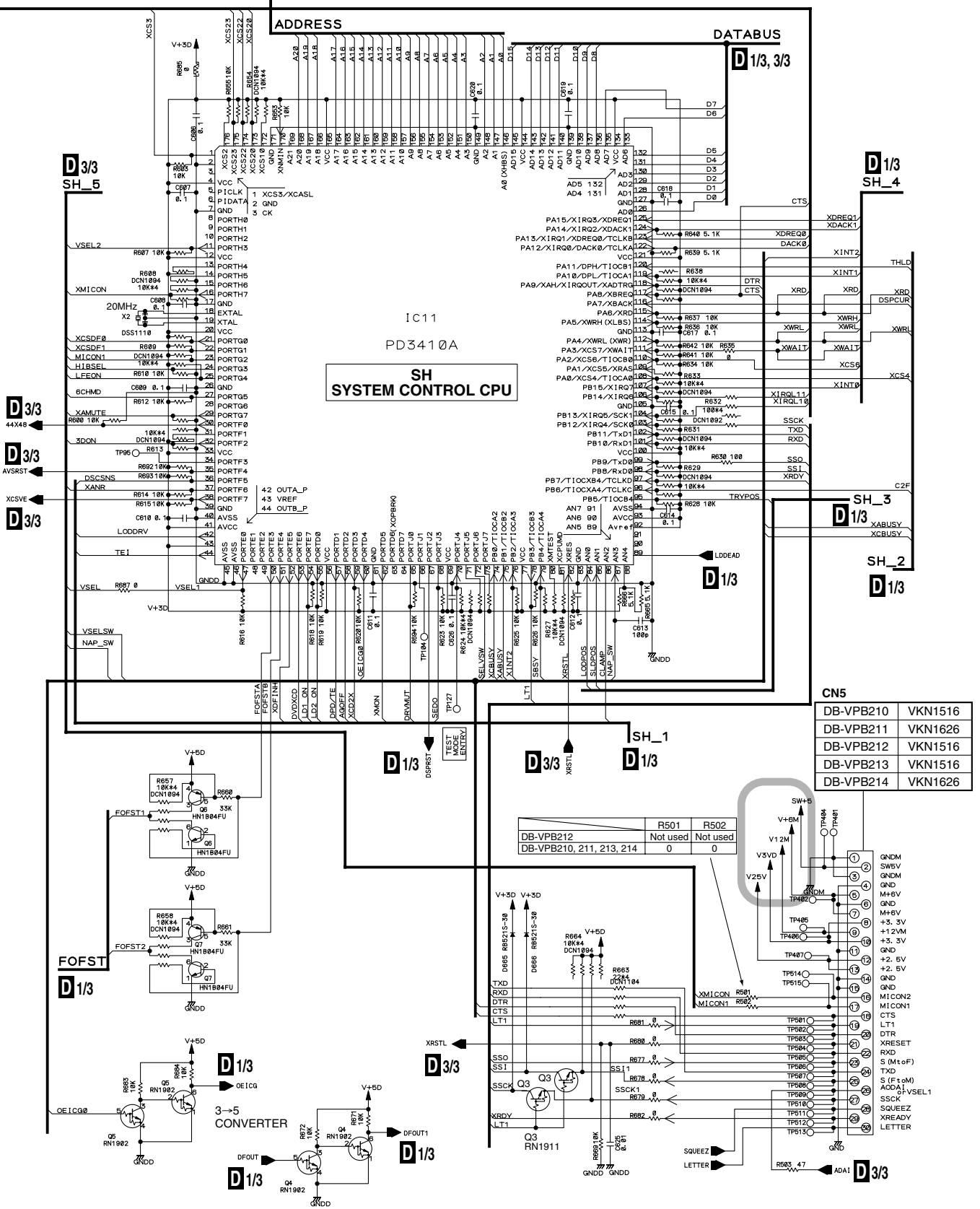

3.1.5 DVDM ASSY (3/3)

D 3/3 DVDM ASSY (VWS1446, VWS1449, VMS1447, VWS1448, VWS1450)

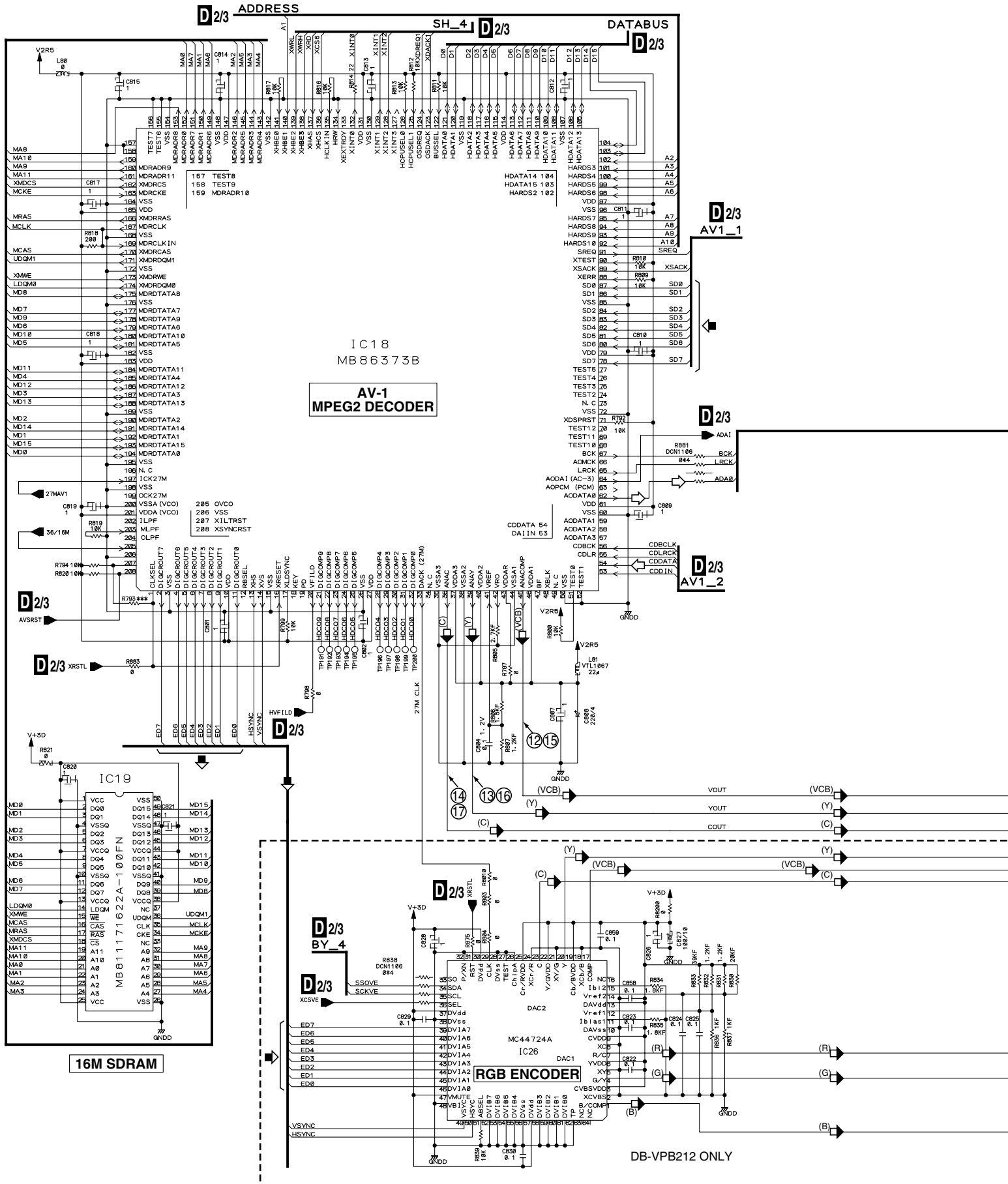

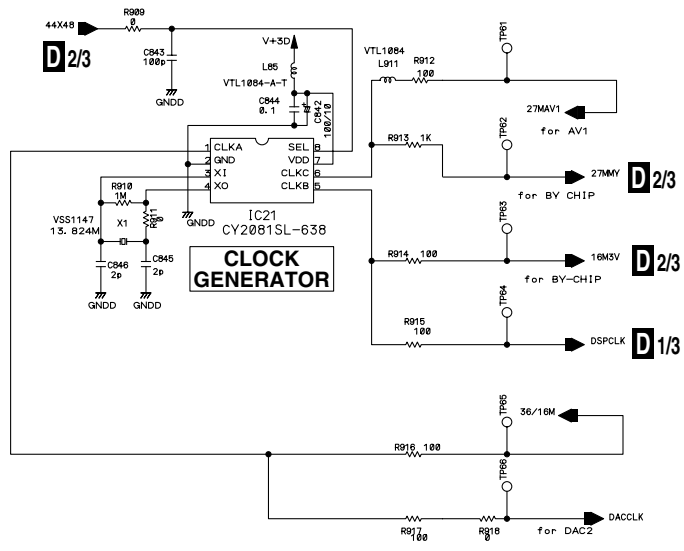

- ◁ : AUDIO SIGNAL ROUTE
- : ROM DATA SIGNAL ROUTE
- (VCB) : V/CB SIGNAL ROUTE
- (Y) : Y SIGNAL ROUTE
- (C) : C SIGNAL ROUTE
- (R) : R SIGNAL ROUTE
- (G) : G SIGNAL ROUTE
- (B) : B SIGNAL ROUTE

RESISTOR
 : RS1/18S~
 : RS1/18S~
CAPACITOR
 : CKSQ***~
 : CCSR***~ or CKSR***~

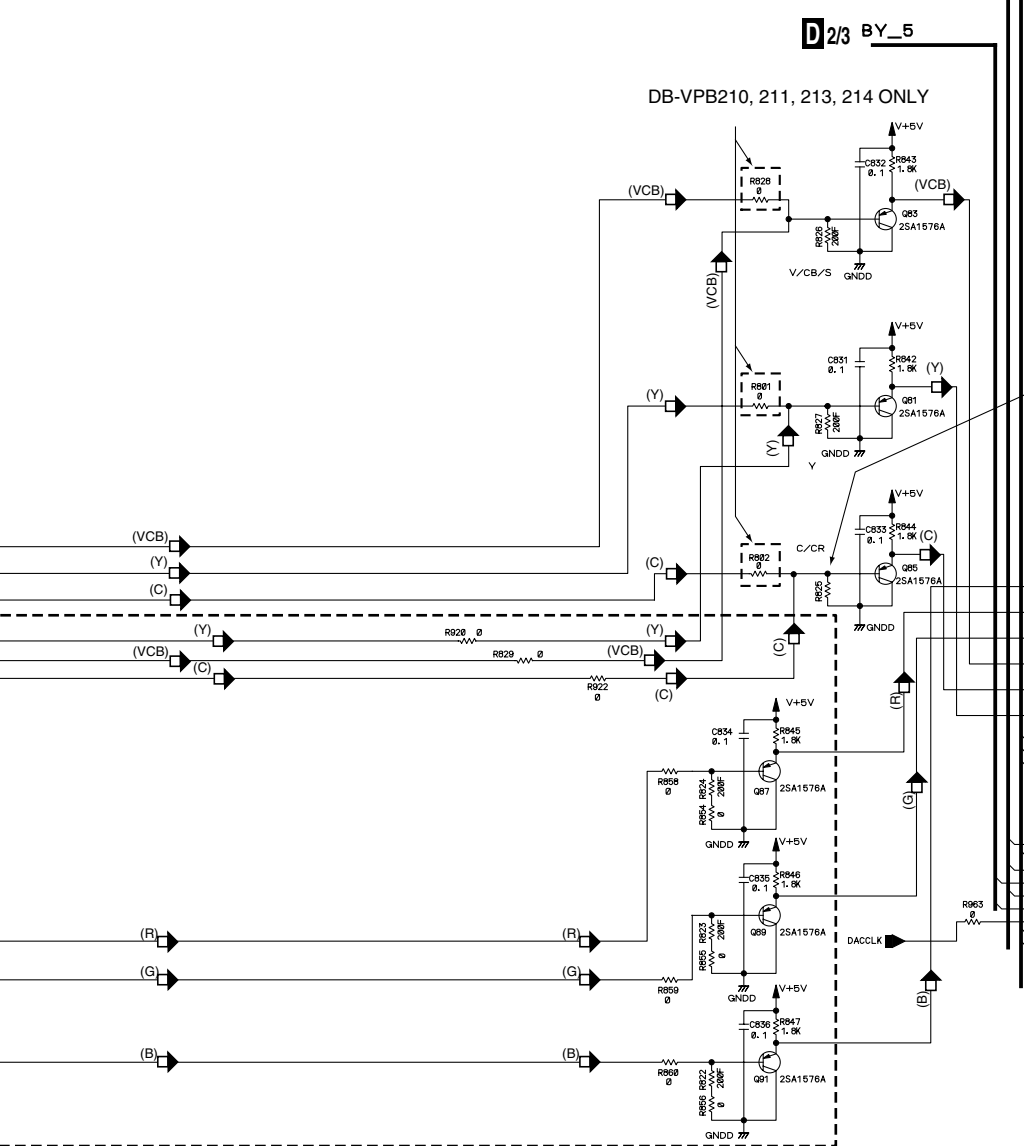

R825
 180F: DB-VPB212
 200F: DB-VPB210, 211, 213, 214

CN5

DB-VPB210	VKN1516
DB-VPB211	VKN1626
DB-VPB212	VKN1516
DB-VPB213	VKN1516
DB-VPB214	VKN1626

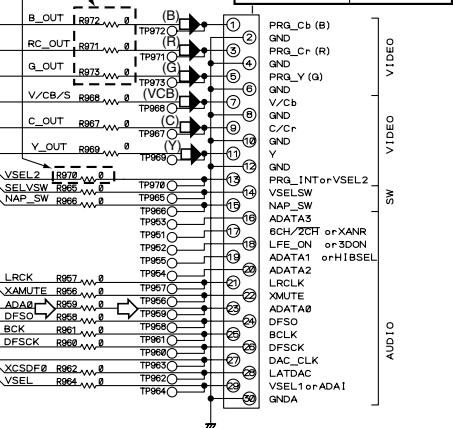

WAVEFORMS

Note : The encircled numbers denote measuring point in the schematic diagram.

Measurement condition : No. 1 to 4 and 6 to 11 : MJK1, Title 1-chp 1 or TDV-540, Title 2-chp1
 No. 5 : CD, ABEX-784 Track 1 or PHILIPS SBC 429 Track1
 No. 12 to 14 : MJK1, Title 1-chp 4 or TDV-540, Title 2-chp1
 No. 15 to 17 : MJK1, Title 1-chp 5 or TDV-540, Title 2-chp1

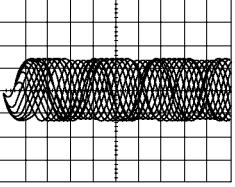
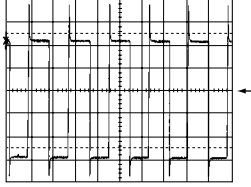
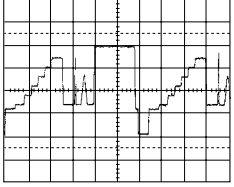
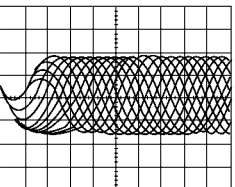
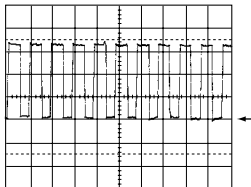
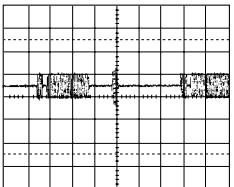
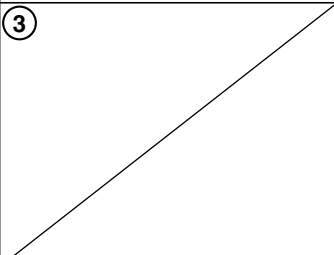
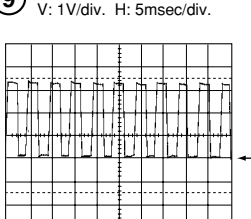
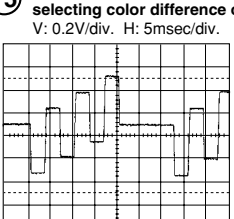
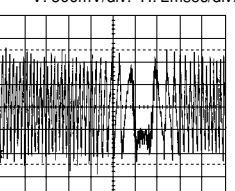
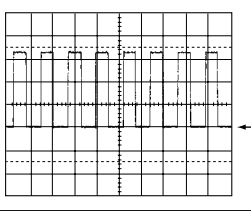
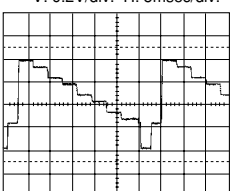
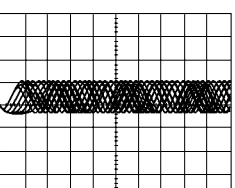
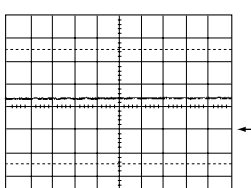
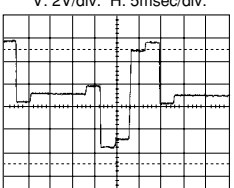
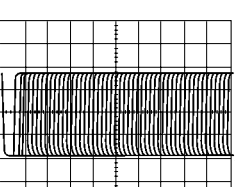
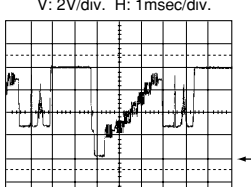
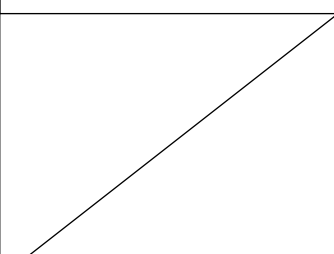
<p>1 Foot of R169 (RF) V: 100mV/div. H: 0.2μsec/div.</p> 	<p>7 IC3 - pin 41 (REGB) V: 1V/div. H: 5msec/div.</p> 	<p>13 IC18 - pin 39 (Y output) V: 0.2V/div. H: 5msec/div.</p> 
<p>2 TP2 (RFO) V: 500mV/div. H: 0.1μsec/div.</p> 	<p>8 Foot of R261 (FPWM) V: 1V/div. H: 5msec/div.</p> 	<p>14 IC18 - pin 36 (C output) V: 0.2V/div. H: 5msec/div.</p> 
<p>3</p> 	<p>9 Foot of R262 (VPWM) V: 1V/div. H: 5msec/div.</p> 	<p>15 IC18 - pin 45 (Cs output when selecting color difference output) V: 0.2V/div. H: 5msec/div.</p> 
<p>4 TP3 (Tracking Error) (AI-Inner Tracking Off) V: 500mV/div. H: 2msec/div.</p> 	<p>10 Foot of R263 (PPWM) V: 1V/div. H: 5msec/div.</p> 	<p>16 IC18 - pin 39 (Y output when selecting color difference output) V: 0.2V/div. H: 5msec/div.</p> 
<p>5 IC2 - pin 39 (EFM before slice) V: 1V/div. H: 1μsec/div.</p> 	<p>11 Foot of R264 (RPWM) V: 1V/div. H: 5msec/div.</p> 	<p>17 IC18 - pin 36 (Cr output when selecting color difference output) V: 2V/div. H: 5msec/div.</p> 
<p>6 IC2 - pin 1 (EFM) V: 1V/div. H: 0.2μsec/div.</p> 	<p>12 IC18 - pin 45 (Composite Video output) V: 2V/div. H: 1msec/div.</p> 	<p>12</p> 

3.2 PCB CONNECTION DIAGRAM

NOTE FOR PCB DIAGRAMS :

1. Part numbers in PCB diagrams match those in the schematic diagrams.
2. A comparison between the main parts of PCB and schematic diagrams is shown below.

Symbol In PCB Diagrams	Symbol In Schematic Diagrams	Part Name
		Transistor
		Transistor with resistor
		Field effect transistor
		Resistor array
		3-terminal regulator

3. The parts mounted on this PCB include all necessary parts for several destinations.
For further information for respective destinations, be sure to check with the schematic diagram.
4. View point of PCB diagrams.

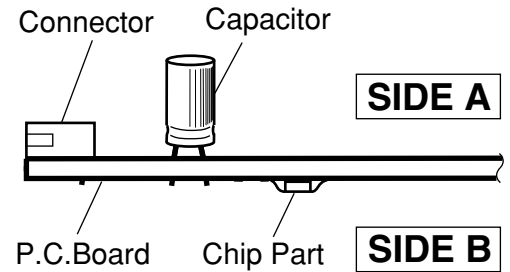

3.2.1 LOAB and SMEB ASSYS

A LOAB ASSY

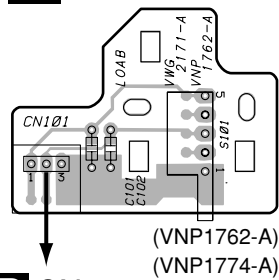

D CN1

A LOAB ASSY

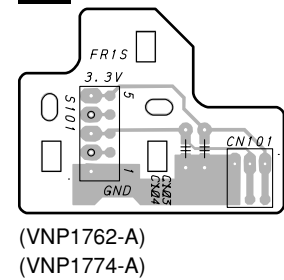

B SMEB ASSY

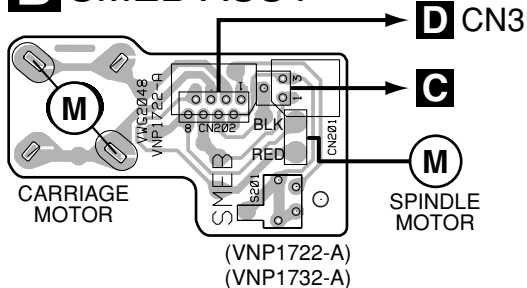

SIDE A

SIDE B

3.2.2 DVDM ASSY

D DVDM ASSY

• This PCB is a four-layered board.

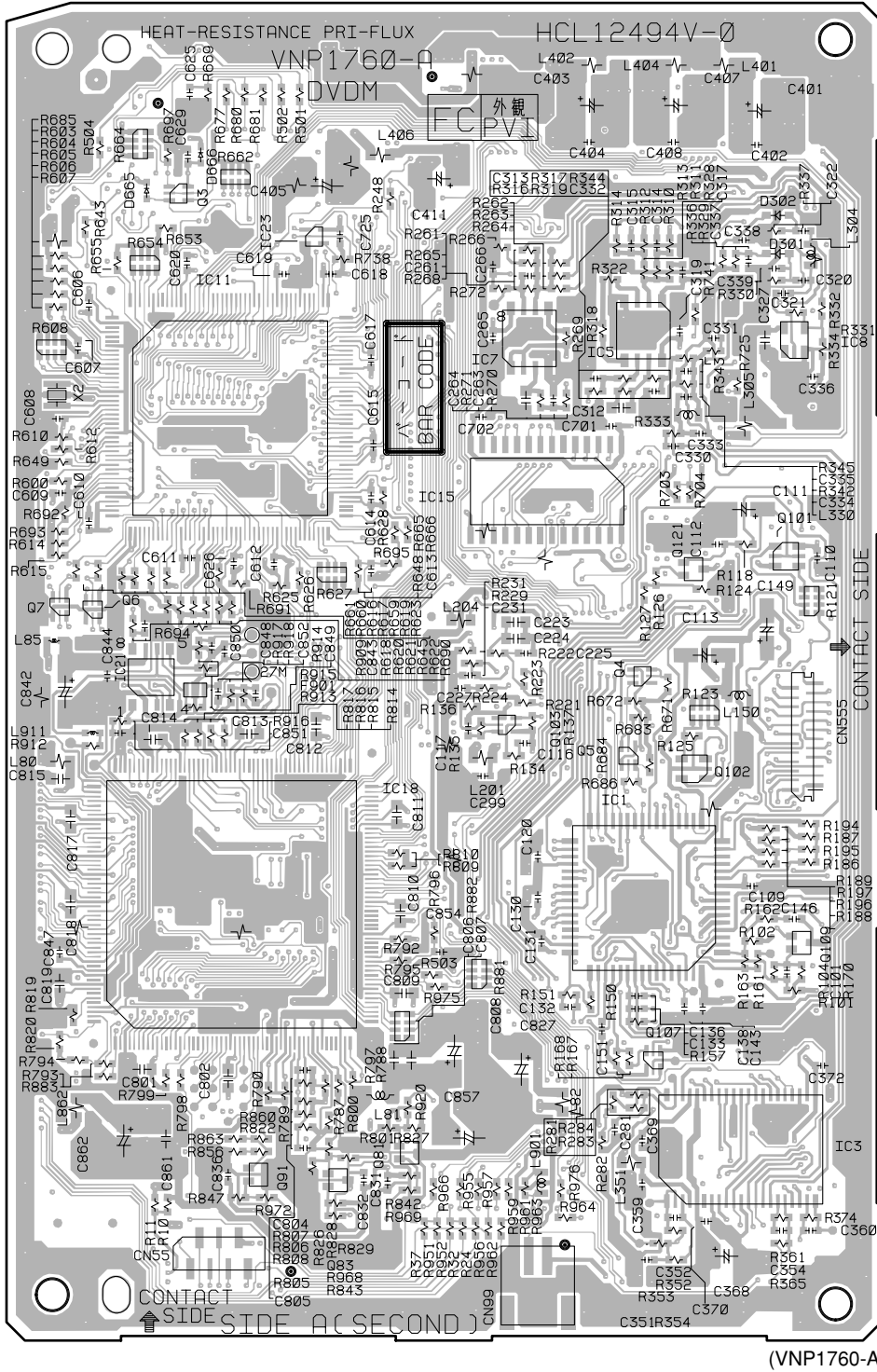

- Q3
- IC7 IC5 IC8
- IC11
- IC15
- Q121 Q101
- Q7 Q6
- IC21 Q4
- Q103
- Q5 Q102
- IC18 IC1
- Q109
- Q107
- Q81 IC3
- Q91 Q83

SIDE A

(VNP1760-A)

D DVDM ASSY

• This PCB is a four-layered board.

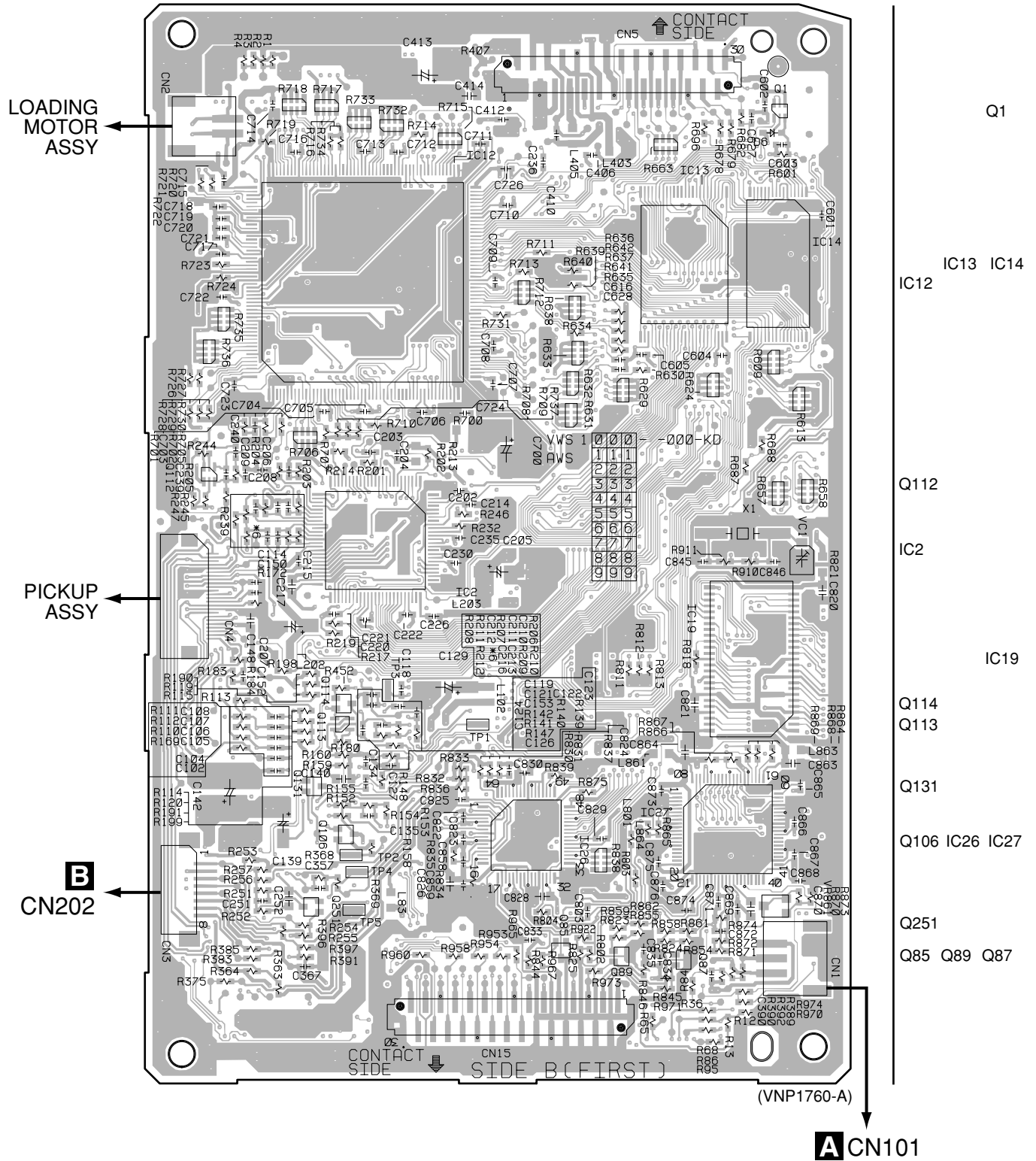

SIDE B

3.2.3 IC

• The information shown in the list is basic information and may not correspond exactly to that shown in the schematic diagrams.

• List of IC

LC78652W, PD3410A, MB86373B

■ LC78652W (DVD M ASSY : IC2)

• DSP IC

• Block Diagram

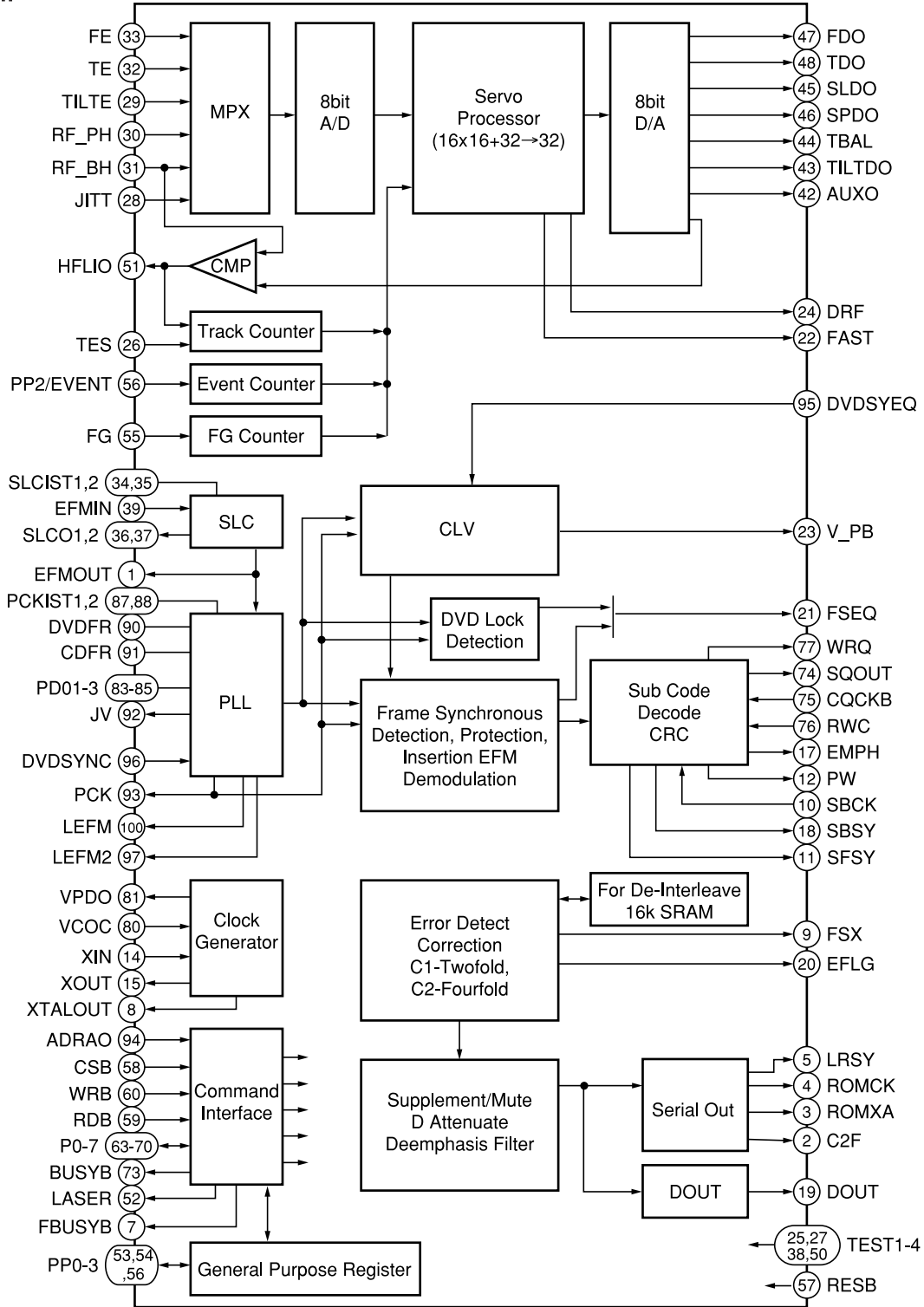

●Pin Function

No.	Pin Name	I/O	Function
1	EFMOUT	O	Output the state that was binary-stated value EFM
2	C2F	O	C2 flag output
3	ROMXA	O	CD-ROM data output
4	ROMCK	O	Shift clock output for CD-ROM data output
5	LRSY	O	L/R clock output for CD-ROM data output
6	PP3	I/O	General-purpose port input/output / DVD sync. signal input N ch-OD output
7	FBUSYB	O	Busy signal output of DSP process operation N ch-OD output
8	XTALOUT	O	External system clock output
9	FSX	O	CD 1 frame sync. signal output
10	SBCK	I	Subcode reading out clock input
11	SFSY	O	Frame sync. signal output of subcode
12	PW	O	Subcode P, Q, R, S, T, U, V and W output
13	VSS	–	GND pin
14	XIN	I	Connect a crystal resonator (16.9344MHz)
15	XOUT	O	Connect a crystal resonator
16	DVDD1	–	3.3V power supply of the oscillation circuit
17	EMPH	O	Monitor pin of the deemphasis
18	SBSY	O	Sync. signal output of the subcode block
19	DOUT	O	Audio EIAJ data output
20	EFLG	O	Error correction state monitor of the error correction C1 and C2
21	FSEQ	O	Detection monitor of the CD/DVD frame sync. signal
22	FAST	O	Playback speed monitor N ch-OD output
23	V_PB	O	Monitor output of the rough servo/CLV control
24	DRF	O	In focus monitor
25	TEST3	I	Test input 3
26	TES	I	Tracking error signal input
27	TEST2	I	Test input 2
28	JITT	I	Jitter quantity detecting signal input of EFM PLL
29	TILTE	I	Tilt error signal input
30	RF_PH	I	RF peak hold signal input
31	RF_BH	I	RF bottom hold signal input
32	TE	I	Tracking error signal input
33	FE	I	Focus error signal input
34	SLCIST1	–	Current setting pin 1 of the constant current charge pump for SLC
35	SLCIST2	–	Current setting pin 2 of the constant current charge pump for SLC
36	SLCO1	O	Control output 1 for SLC
37	SLCO2	O	Control output 2 for SLC
38	TEST1	I	Test input 1
39	EFMIN	I	EFM/EFM + input
40	AVDD	–	5V power supply of A/D and D/A for servo
41	AVSS	–	GND of A/D and D/A for servo
42	AUXO	O	DA auxiliary output
43	TILTDO	O	Tilt control signal output
44	TBAL	O	Tracking balance control signal output
45	SLDO	O	Sled control signal output
46	SPDO	O	Spindle control signal output
47	FDO	O	Focus control signal output
48	TDO	O	Tracking control signal output
49	VREF	–	Reference level of D/A for servo
50	TEST4	I	Test input 4

No.	Pin Name	I/O	Pin Function
51	HFLIO	I/O	Mirror detection signal input/output
52	LASER	O	Output pin for laser ON/OFF control
53	PP0/DVD_CDB	I/O	General-purpose port input/output / Disc discrimination signal output
54	PP1/CRCERRB	I/O	General-purpose port input/output / Subcode CRC result signal output
55	FG	I	FG counter input
56	PP2/EVENT	I/O	General-purpose port input/output / Event counter input
57	RESB	I	Reset input
58	CSB	I	Chip select input
59	RDB	I	Internal state reading signal input
60	WRB	I	Command / data writing signal input
61	DVDD2	-	5V power supply
62	VSS	-	GND
63	P0	I/O	Command / data input/output
64	P1		
65	P2		
66	P3		
67	P4		
68	P5		
69	P6		
70	P7		
71	VSS	-	GND
72	DVDD1	-	3.3V power supply for internal
73	BUSYB	O	Busy signal output of command process
74	SQOUT	O	Serial output of subcode Q
75	CQCKB	I	Shift clock input for subcode Q data output
76	RWC	I	Update permission input of subcode Q
77	WRQ	O	Read out ready monitor of subcode Q
78	AVSS	-	PLL GND for internal system clock
79	VRPFR	-	VCO oscillation range setting of PLL for system clock
80	VCOC	I	Connect a PLL filter for system clock
81	VPDO	O	
82	AVDD	-	PLL 5V power supply for system clock
83	PDO1	I/O	PLL filter connection pin 1 for EFM playback
84	PDO2	I/O	PLL filter connection pin 2 for EFM playback
85	PDO3	I/O	PLL filter connection pin 3 for EFM playback
86	AVSS	-	PLL GND for EFM playback
87	PCKIST1	-	Current setting 1 of PLL constant current charge pump for EFM playback
88	PCKIST2	-	Current setting 2 of PLL constant current charge pump for EFM playback
89	AVDD	-	PLL 5V power supply for EFM playback
90	DVDFR	-	VCO oscillation range setting of PLL for EFM playback 1
91	CDFR	-	VCO oscillation range setting of PLL for EFM playback 2
92	JV	O	Jitter output of PLL clock for EFM playback
93	PCK	O	Bit clock output for EFM playback
94	ADRAO	I	Address input
95	DVDSYEQ	I	DVD synchronize pulse input
96	DVDSYNC	I	DVD synchronous signal input
97	LEFM2	O	Output the state that cut and out a signal which was binary-stated value EFM with PCK 2
98	DVDD1	-	3.3V power supply for I/O
99	VSS	-	GND
100	LEFM	O	Output the state that cut and out a signal which was binary-stated value EFM with PCK 1

■ PD3410A (DVDM ASSY : IC11)

• System Control IC

● Pin Function

No.	Mark	Pin Name	I/O	Function
1	XCS3/XCASL	XCS3	O	PD4995A (MY CHIP) chip select signal output
2	GND	GND	–	GND
3	CK	HCPUCK	O	N.C.
4	VCC	V+3D	–	V+3D
5	PICLK	–	I/O	N.C.
6	PIDATA	–	I/O	N.C.
7	GND	GND	–	GND
8	PORTH0	–	O	N.C.
9	PORTH1	–	O	N.C.
10	PORTH2	36MVH	O	BU2158F (Clock generator)
11	PORTH3	V_SEL2	O	Composite/S switching signal output of the skirt terminal [WY model]
12	VCC	V+3D	–	V+3D
13	PORTH4	–	O	N.C.
14	PORTH5	–	O	N.C.
15	PORTH6	–	O	N.C.
16	PORTH7	–	O	N.C.
17	GND	GND	–	GND
18	EXTAL	EXTAL	I	Connect a ceramic resonator
19	XTAL	XTAL	O	
20	VCC	V+3D	–	V+3D
21	PORTG0	XCSDf0	O	DAC chip select signal output (←XLAT3)
22	PORTG1	–	O	N.C.
23	PORTG2	–	O	N.C.
24	PORTG3	–	O	N.C.
25	PORTG4	–	O	N.C.
26	GND	GND	–	GND
27	PORTG5	–	O	N.C.
28	PORTG6	–	O	N.C.
29	PORTG7	XAMUTE	O	Last stage mute signal output of the audio
30	PORTF0	44X48	O	DAC 44/48 FS switching signal output
31	PORTF1	–	I	N.C.
32	PORTF2	3DON	O	3D audio ON/bypass switching signal output
33	VCC	V+3D	–	V+3D
34	PORTF3	–	O	N.C.
35	PORTF4	XAVSRST	O	Sync. reset port
36	PORTF5	–	O	N.C.

No.	Mark	Pin Name	I/O	Function
37	PORTF6	–	O	N.C.
38	PORTF7	XCSVE	O	Serial communication enable signal output of the video encoder [WY model]
39	GND	GND	–	GND
40	AVSS	GND	–	GND
41	AVCC	V+3D	–	V+3D
42	OUTA_P	LODRV	O	Loading drive output
43	VREF	V+3D	–	V+3D
44	OUTB_P	TEI	O	Tracking offset signal output
45	AVSS	GND	–	GND
46	AVSS	GND	–	GND
47	PORTE0	V_SEL	O	Component/composite switching signal output
48	PORTE1	–	I	N.C.
49	PORTE2	–	I	N.C.
50	PORTE3	FOFST1	I/O	Focus offset adjustment output 1
51	PORTE4	FOFST2	I/O	Focus offset adjustment output 2
52	PORTE5	XDFINH	I/O	Defect shunt signal output
53	PORTE6	DVD/XC	O	DVD/CD switching signal output
54	PORTE7	LD1_ON	O	650 nm laser diode ON signal output
55	PORTD0	LD2_ON	O	780 nm laser diode ON signal output
56	VCC	V+3D	–	V+3D
57	PORTD1	DPD/TE	O	1 beam/3 beams switching signal output
58	PORTD2	AGOFF	O	AGC ON/OFF switching signal output of RF IC
59	PORTD3	XCD2X	O	Signal output for switching the double speed playback (VCD)
60	PORTD4	OEICG	O	OEIC gain switching signal output
61	GND	GND	–	GND
62	PORTD5	XMON	O	ON/OFF switching signal output of the spindle motor control output
63	PORTD6	–	O	N.C.
64	PORTD7	–	I	N.C.
65	PORTJ0	XDRVMUT	O	Driver mute output
66	PORTJ1	–	O	N.C.
67	PORTJ2	XDSPRST	O	Servo DSP reset
68	PORTJ3	–	I	N.C.
69	VCC	V+3D	–	V+3D
70	PORTJ4	TM_ENT	I	Test mode entry
71	PORTJ5	–	O	N.C.
72	PORTJ6	VSEL_SW	I	Component/composite SW input
73	PORTJ7	–	I	N.C.
74	PB0/TIOCA2	XCBUSY	I	Command busy input
75	PB1/TIOCB2	XABUSY	I	Auto-sequence busy input
76	PB2/TIOCA3	XINT2	I	Interrupt input 2 (AV-1)
77	VCC	V+3D	–	V+3D
78	PB3/TIOCB3	LT1	O	Communication response signal output to the FL controller
79	PB4/TIOCA4	SBSY	I	Subcode block sync. input
80	XMTEST	–	I	Test terminal (V+3D)
81	XCPUMD	–	I	Test terminal (V+3D)
82	XRES	XRESET	I	Reset input

No.	Mark	Pin Name	I/O	Function
83	GND	GND	–	GND
84	AN0	LODPOS	I	Loading position input
85	AN1	SLDPOS	I	Slider position input
86	AN2	–	I	N.C.
87	AN3	NAP_SW	I	NTSC/AUTO/PAL SW input
88	AN4	XOEM	I	Input terminal of OEM model protection
89	AN5	LDDEAD		Input for LD current value display
90	AN6	–	I	N.C.
91	AN7	–	I	N.C.
92	Avref	V+3D	–	V+3D
93	AVCC	V+3D	–	V+3D
94	AVSS	GND	–	GND
95	PB5/TIOCB4	–	I	N.C.
96	PB6/TIOXA4/TCLKC	C2F	I	C2 error input
97	PB7/TIOXB4/TCLKD	XRDF	I	Communication request input from the FL controller
98	PB8/RxD0	SSI	I	Serial data input (FL controller)
99	PB9/TxD0	SSO	O	Serial data output (FL controller)
100	VCC	V+3D	–	V+3D
101	PB10/RxD1	RXD	I	Data input of the RS-232C
102	PB11/TxD1	TXD	O	Data output of the RS-232C
103	PB12/XIRQ4/SCK0	SSCK	I/O	Serial clock output (FL controller)
104	PB13/XIRQ5/SCK1	XIRQL10	I	Interrupt input #0 (MY CHIP)
105	GND	GND	–	GND
106	PB14/XIRQ6	XIRQL11	I	Interrupt input #1 (MY CHIP)
107	PB15/XIRQ7	XINT0	I	Interrupt input #0 (AV-1)
108	PA0/XCS4/TIOCA0	XCS4	O	Servo DSP chip select signal output
109	PA1/XCS5/XRAS	–	O	N.C.
110	PA2/XCS6/TIOCB0	XCS6	O	AV-1 chip select signal output
111	XWAIT	XWAIT	I	Wait signal input
112	XWRL	XWRL	O	Write pulse output L
113	GND	GND	–	GND
114	XWRH	XWRH	O	Write pulse output H
115	XRD	XRD	O	Read pulse output
116	PA7/XBACK	XCURDET	I	Over-current detection signal input
117	PA8/XBREQ	CTS	I	RS-232C transfer permit input
118	PA9/XAH/XIRQOUT/ XADTRG	DTR	O	RS-232C transfer permit output
119	PA10/DPL/TIOCA1	XINT1	I	Interrupt input 1 (AV-1)
120	PA11/DPH/TIOCB1	THLD	I	Tracking hold signal input
121	VCC	V+3D	–	V+3D
122	PA12/XIRQ0/DACK0/ TCLKA	DACK0	O	DMA response output (MY CHIP)
123	PA13/XIRQ1/ XDREQ0/TCLKB	XDREQ0	I	DMA request input (MY CHIP)
124	PA14/XIRQ2/XDACK1	XDACK1	O	DMA response output (AV-1)
125	PA15/XIRQ3/XDREQ1	XDREQ1	I	DMA request input (AV-1)
126	AD0	D0	I/O	Data bus 0

No.	Mark	Pin Name	I/O	Function
127	GND	GND	–	GND
128	AD1	D1	I/O	Data bus 1
129	AD2	D2	I/O	Data bus 2
130	AD3	D3	I/O	Data bus 3
131	AD4	D4	I/O	Data bus 4
132	AD5	D5	I/O	Data bus 5
133	AD6	D6	I/O	Data bus 6
134	VCC	V+3D	–	V+3D
135	AD7	D7	I/O	Data bus 7
136	AD8	D8	I/O	Data bus 8
137	AD9	D9	I/O	Data bus 9
138	AD10	D10	I/O	Data bus 10
139	GND	GND	–	GND
140	AD11	D11	I/O	Data bus 11
141	AD12	D12	I/O	Data bus 12
142	AD13	D13	I/O	Data bus 13
143	AD1	D14	I/O	Data bus 14
144	VCC	V+3D	–	V+3D
145	AD15	D15	I/O	Data bus 15
146	A0 (XHBS)	A0	O	Address bus 0
147	A1	A1	O	Address bus 1
148	A2	A2	O	Address bus 2
149	GND	GND	–	GND
150	A3	A3	O	Address bus 3
151	A4	A4	O	Address bus 4
152	A5	A5	O	Address bus 5
153	A6	A6	O	Address bus 6
154	A7	A7	O	Address bus 7
155	A8	A8	O	Address bus 8
156	A9	A9	O	Address bus 9
157	A10	A10	O	Address bus 10
158	A11	A11	O	Address bus 11
159	A12	A12	O	Address bus 12
160	A13	A13	O	Address bus 13
161	A14	A14	O	Address bus 14
162	A15	A15	O	Address bus 15
163	A16	A16	O	Address bus 16
164	A17	A17	O	Address bus 17
165	VCC	V+3D	–	V+3D
166	A18	A18	O	Address bus 18
167	A19	A19	O	Address bus 19
168	A20	A20	O	Address bus 20 [RAM model]
169	A21	A21	O	N.C.
170	XNMI	XNMI	I	V+3D
171	GND	GND	–	GND
172	XCS10	–	O	N.C.
173	XCS20	XCS20	O	Chip select signal output of the flash ROM
174	XCS22	–	O	Chip select signal output of the GUI ROM [OEM model]
175	XCS23	XCS23	O	Chip select signal output of the SRAM
176	XCS2	–	O	N.C.

■ MB86373B (DVDM ASSY : IC18)

- MPEG2 Decoder IC

● Block Diagram

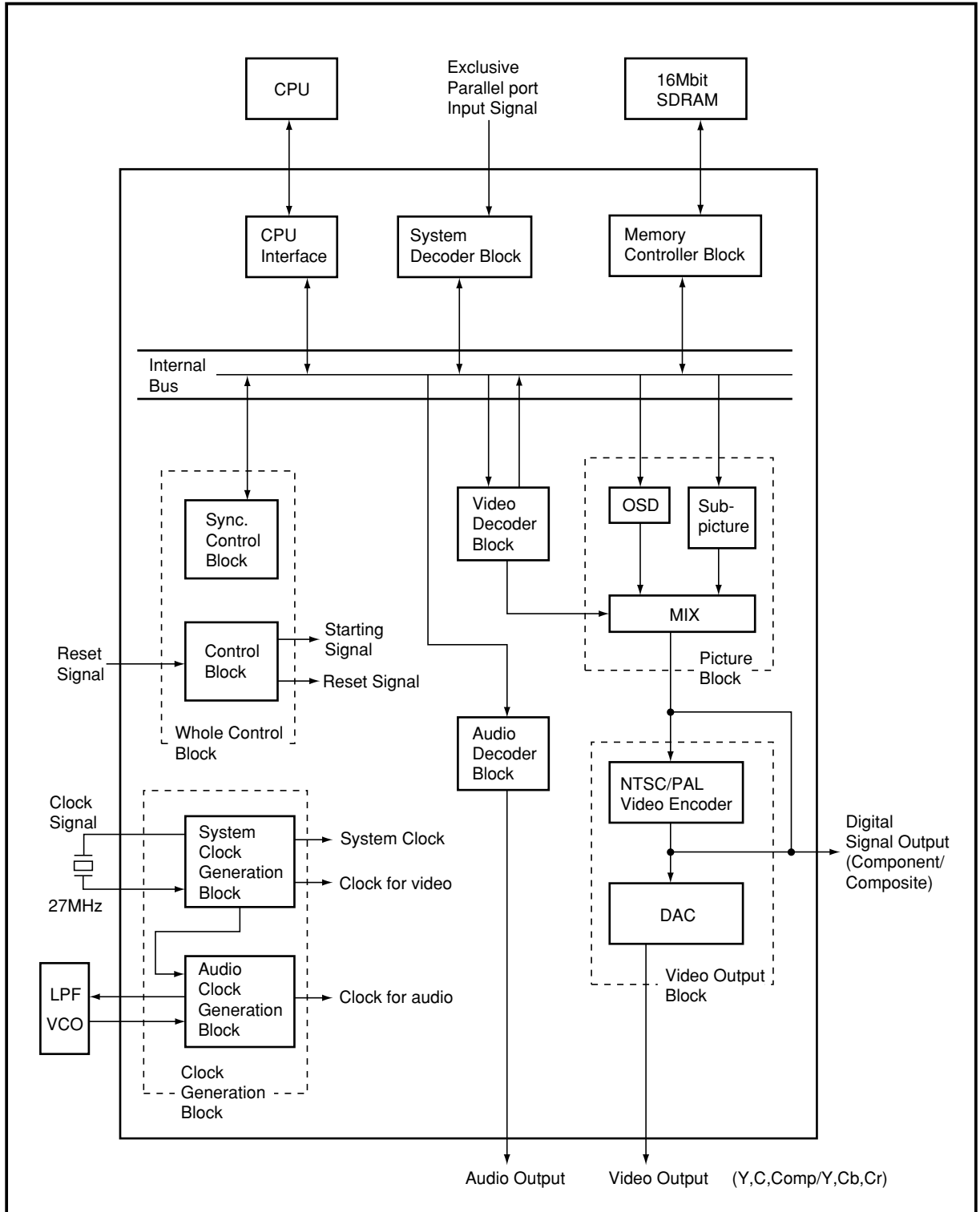

● Pin Function

No.	Pin Name	I/O	Function	No.	Pin Name	I/O	Function
1	CLKSEL	I	ON/OFF signal of PLL ("H" : ON, "L" : OFF)	27	VDD	-	2.5V power supply
2	DIGCPN7	O	Digital component signal output (MSB) Digital Y signal output (9-bit) (MSB)	28	DIGCOMP4	O	Digital composite signal output Digital C signal output
3	VSS	-	GND	29	DIGCOMP3		
4	DIGCPN6	O	Digital component signal output Digital Y signal output (9-bit)	30	DIGCOMP2		
5	DIGCPN5			31	DIGCOMP1		
6	DIGCPN4			32	DIGCOMP0		
7	DIGCPN3			33	DACK	O	27 MHz clock output
8	DIGCPN2			34	N.C.	-	Non connection
9	DIGCPN1			35	VSSA3	-	GND (D/A converter)
10	VDD	-	2.5V power supply	36	ANAC	O	Analog color (C) output signal
11	DIGCPN0	O	Digital component signal output (LSB) Digital Y signal output (9-bit) (LSB)	37	VDDA3	-	2.5V power supply (for built-in D/A converter only)
12	RBSEL	O	Cb and Cr discrimination signal at the digital component signal output. LSB at the digital Y signal output.	38	VSSA2	-	GND (D/A converter)
13	XHS	O	Horizontal sync. output signal	39	ANAY	O	Analog luminance (Y) output signal
14	XVS	O	Vertical sync. output signal	40	VDDA2	-	2.5V power supply (for built-in D/A converter only)
15	VSS	-	GND	41	VREF	I	Reference voltage for D/A converter
16	XRESET	I	LSI reset signal	42	VRO	O	Internal current setting pin of D/A converter
17	XLDCSYNC	I	External sync. signal input (LD mode)	43	VDDA4	-	2.5V power supply (for built-in D/A converter only)
18	KEY	O	KEY signal for LD and OSD overlay (LD mode)	44	VSSA1	-	GND (D/A converter)
19	PD	O	Phase comparison result output signal of horizontal sync. (LD mode)	45	ANACOMP	O	Analog composite output signal
20	VFLD	O	Field discrimination signal at the digital signal output H : even field L : odd field	46	VDDA1	-	2.5V power supply (for built-in D/A converter only)
21	DIGCOMP9	O	Digital composite signal output (MSB) Digital C signal output (MSB)	47	BF	O	Burst flag signal
22	DIGCOMP8			48	XBLK	O	H/V composite blanking signal
23	DIGCOMP7			49	TEST4	O	Normally, set to "open".
24	DIGCOMP6			50	VSS	-	GND
25	DIGCOMP5			51	TEST0	I	Normally, set to "open".
26	VSS			-	GND	52	TEST1

No.	Pin Name	I/O	Function	No.	Pin Name	I/O	Function		
53	DAIIN	I	Digital data input of external input (SPDIF)	92	HADRS10	I	CPU address bus signal (MSB)		
54	CDDATA	I	Audio data input of external input (correspond to CD)	93	HADRS9	I	CPU address bus signal		
55	CDLR	I	Data channel clock input of external input (correspond to CD)	94	HADRS8				
56	CDBCK	I	Data clock input of external input (correspond to CD)	95	HADRS7				
57	AODATA3	O	Audio decode data	96	VSS	-	GND		
58	AODATA2			97	VDD	-	2.5V power supply		
59	AODATA1			98	HADRS6	I	CPU address bus signal		
60	VSS	-	GND	99	HADRS5				
61	VDD	-	2.5V power supply	100	HADRS4				
62	AODATA0	O	Audio decode data	101	HADRS3				
63	AOPCM	O	Digital audio interface output (compression data)	102	HADRS2	I/O	CPU address bus signal (LSB)		
64	AODAI	O	Digital audio interface output (decode data)	103	HDATA15		CPU data bus signal (MSB)		
65	LRCK	O	Data channel clock for D/A and digital filter	104	HDATA14	I/O	CPU data bus signal		
66	AOMCK	O	Master clock for D/A and digital filter	105	HDATA13				
67	BCK	O	Bit clock for D/A and digital filter	106	HDATA12				
68	TEST2	I	Normally, set to "open"	107	VSS	-	GND		
69	TEST3			108	HDATA11	I/O	CPU data bus signal		
70	NC	-	Non connection	109	HDATA10				
71	XDSPRST	I	Normally, set to "open".	110	HDATA9				
72	VSS	-	GND	111	HDATA8				
73	TEST5	O	Normally, set to "open".	112	HDATA7				
74	NC	-	Normally, set to "open".	113	HDATA6	I/O	CPU data bus signal		
75	NC			114	VDD			-	2.5V power supply
76	NC			115	HDATA5			I/O	CPU data bus signal
77	NC			116	HDATA4				
78	SD7	I	Parallel data input	117	HDATA3	I/O	CPU data bus signal		
79	VDD	-	2.5V power supply	118	HDATA2				
80	SD6	I	Parallel data input	119	VSS	-	GND		
81	SD5			120	HDATA1	I/O	CPU data bus signal		
82	SD4			121	HDATA0		CPU data bus signal (LSB)		
83	SD3			122	BUSSEL	I	Bus width selection signal (0 : 8-bit bus, 1 : 16-bit bus)		
84	SD2			123	XOSDACK	I	OSD data acknowledge signal		
85	VSS	-	GND	124	XOSDREQ	O	OSD data request signal		
86	SD1	I	Parallel data input	125	HCPUSEL1	I	CPU selection signal (00 :SPARC, 01 :86 system, 10 :68 system, 11 :Reserve)		
87	SD0			126	HCPUSEL0				
88	XERR	I	Error input signal	127	XINT3	O	Interrupt request signal to the CPU		
89	XSACK	I	Acknowledge signal	128	XINT2				
90	XTEST	I	Set to "H" at normal use	129	XINT1				
91	SREQ	O	Data request signal	130	VSS	-	GND		

No.	Pin Name	I/O	Function	No.	Pin Name	I/O	Function
131	VDD	–	2.5V power supply	170	XMDRCAS	O	CAS signal for SDRAM
132	XINT0	O	Interrupt request signal to CPU	171	XMDRDQM1	O	Input mask / output enable signal for SDRAM
133	XEXTRDY	O	SPARC, 68 system : Ready signal to CPU 86 system : Acknowledge (ACK) signal to CPU	172	VSS	–	GND
134	HRW	I	CPU read / write signal	173	XMDRWE	O	Write enable signal for SDRAM
135	HCLKIN	I	Host clock input	174	XMDRDQM0	O	Input mask / output enable signal for SDRAM
136	XHCS	I	LSI chip select signal	175	MDRDAT8	I/O	Data bus signal for SDRAM
137	XHAS	I	SPARC, 68 system : CPU address strobe 86 system : CPU address status	176	VSS	–	GND
138	XHBE3	I	CPU byte enable signal	177	MDRDAT7	I/O	Data bus signal for SDRAM
139	XHBE2			178	MDRDAT9		
140	XHBE1			179	MDRDAT6		
141	XHBE0			180	MDRDAT10		
142	VSS	–	GND	181	MDRDAT5		
143	MDRADR4	O	Address signal for SDRAM	182	VSS	–	GND
144	MDRADR3			183	VDD	–	2.5V power supply
145	MDRADR5			184	MDRDAT11	I/O	Data bus signal for SDRAM
146	MDRADR2			185	MDRDAT14		
147	VDD	–	2.5V power supply	186	MDRDAT12		
148	VSS	–	GND	187	MDRDAT3		
149	MDRADR6	O	Address signal for SDRAM	188	MDRDAT13		
150	MDRADR1			189	VSS	–	GND
151	MDRADR7			190	MDRDAT2	I/O	Data bus signal for SDRAM
152	MDRADR0			191	MDRDAT14		
153	MDRADR8	192	MDRDAT1				
154	VSS	–	GND	193	MDRDAT15		Data bus signal for SDRAM (MSB)
155	TEST6	I	"L" status normally	194	MDRDAT0	I/O	Data bus signal for SDRAM (LSB)
156	TEST7			195	VSS	–	GND
157	TEST8			196	N.C.	–	Non connection
158	TEST9			197	ICK27M	I	System clock input
159	MDRADR10	O	Address signal for SDRAM	198	VSS	–	GND
160	MDRADR9			199	OCK27M	O	System clock output
161	MDRADR11			200	VSSA(VCO)	–	GND (for VCO only)
162	XMDRCS	O	Chip select signal for SDRAM	201	VDDA(VCO)	–	2.5V power supply (for VCO only)
163	MDRCKE	O	Clock enable signal for SDRAM	202	ILPF	O	PLL block inverter output for audio
164	VSS	–	GND	203	MLPF	I	PLL block inverter input for audio
165	VDD	–	2.5V power supply	204	OLPF	O	Phase detector output for audio
166	XMDRRAS	O	RAS signal for SDRAM	205	OVCO	I	VCO input for audio clock
167	MDRCLK	O	Clock output signal for SDRAM	206	VSS	–	GND
168	VSS	–	GND	207	XPLLST	I	PLL section reset signal
169	MDRCLKIN	I	Clock input signal for SDRAM	208	XSYNCRST	I	SYNC reset signal

3. PCB PARTS LIST

- NOTES: ● Parts marked by "NSP" are generally unavailable because they are not in our Master Spare Parts List.
 ● The Δ mark found on some component parts indicates the importance of the safety factor of the part. Therefore, when replacing, be sure to use parts of identical designation.
 ● When ordering resistors, first convert resistance values into code form as shown in the following examples.
 Ex.1 When there are 2 effective digits (any digit apart from 0), such as 560 ohm and 47k ohm (tolerance is shown by J=5%, and K=10%).
- | | | | | | | | | | |
|-------|---|----------------------|---|----------|---------|---|---|---|---|
| 560 Ω | → | 56 × 10 ¹ | → | 561..... | RD1/4PU | 5 | 6 | 1 | J |
| 47k Ω | → | 47 × 10 ³ | → | 473..... | RD1/4PU | 4 | 7 | 3 | J |
| 0.5 Ω | → | R50..... | | | RN2H | R | 5 | 0 | K |
| 1 Ω | → | 1R0..... | | | RS1P | 1 | R | 0 | K |
- Ex.2 When there are 3 effective digits (such as in high precision metal film resistors).
- | | | | | | | | | | | |
|---------|---|-----------------------|---|-----------|---------|---|---|---|---|---|
| 5.62k Ω | → | 562 × 10 ¹ | → | 5621..... | RN1/4PC | 5 | 6 | 2 | 1 | F |
|---------|---|-----------------------|---|-----------|---------|---|---|---|---|---|

A LOAB ASSY

Mark	Ver. (DB-VPBxxx)	No.	Part No. (for PCS)	Description	Part No. (for MJL)
NSP NSP		SWITCH S101	9965 000 07961	VSK1011	*SM000340R
		OTHERS CN101	—	S3B-PH-K-S, KR CONNECTOR	—
		—	—	VNP1762, PC BOARD LOAB	—

B SMEB ASSY

Mark	Ver. (DB-VPBxxx)	No.	Part No. (for PCS)	Description	Part No. (for MJL)
NSP NSP NSP NSP	210,211,213,214 212	SWITCH S201	9965 000 07962	DSG1016	*SP001020R
		OTHERS CN201	—	52044-0345, 3P FFC CONNECTOR	—
		CN202	—	VKN1212, 8P FFC CONNECTOR	—
		—	—	VNP1695, PC BOARD SMEB	—
		—	—	VNP1722, PC BOARD SMEB	—

C FGSB ASSY

Mark	Ver. (DB-VPBxxx)	No.	Part No. (for PCS)	Description	Part No. (for MJL)
NSP		SEMICONDUCTOR PC101	9965 000 07963	GP2S60	*HW100500R
		RESISTOR R101	—	RS1/10S331J	—

D DVDM ASSY

Mark	Ver. (DB-VPBxxx)	No.	Part No. (for PCS)	Description	Part No. (for MJL)
	212	SEMICONDUCTORS			
		IC21	9965 000 07964	CY2081SL-638	*HC106340R
		IC14	9965 000 07965	KM68V1000CLT-7L	*HC106350R
		IC1	9965 000 07966	LA9701M	*HC105850R
		IC2	9965 000 07967	LC78652W	*HC105860R
		IC3	9965 000 07968	M56788FP	*HC105870R
		IC19	9965 000 07969	MB811171622A-100FN	*HC106040R
		IC18	9965 000 07970	MB86373B	*HC106360R
		IC26	9965 000 07971	MC44724A	*HC106640R
		IC15	9965 000 07972	MN414800CSJ-07	*HC105900R
		IC5,IC7	4822 209 30455	NJM2100M (or BA4510F)	HC10085090
		IC11	9965 000 07973	PD3410A	*HU100400R

Mark	Ver. (DB-VPBxxx)	No.	Part No. (for PCS)	Description	Part No. (for MJJ)
		IC12	9965 000 07974	PE5108A	*HC106370R
		IC8	4822 209 17539	TC7SHU04F	*HC105940R
	210,212	IC13	9965 000 07975	VYW1761 (4M)	*HC106750R
	211	IC13	9965 000 07975	VYW1762 (4M)	*HC106760R
	213,214	IC13	9965 000 07975	VYW1763 (8M)	*HC106380R
		Q106,Q109,Q81,Q83,Q85	4822 130 10698	2SA1576A	HX100012A0
	212	Q87,Q89,Q91	4822 130 10698	2SA1576A	HX100012A0
		Q114,Q121,Q251	4822 130 60669	2SC4081	HX300012A0
		Q131	9965 000 07976	DTC114EUA	*BA000910R
		Q102	4822 130 63838	HN1A01F	BA10011050
		Q103,Q6,Q7	9965 000 07977	HN1B04FU	*BA000920R
		Q101	4822 130 63843	HN1C01F	*BA000930R
		Q112,Q113	9965 000 07978	HN1C01FU	*BA000940R
		Q107,Q4,Q5	9965 000 07979	RN1902	*BA001020R
		Q3	9965 000 07980	RN1911	*BA000960R
		Q1	9965 000 07981	RN4982	*BA001030R
		D301	9965 000 07982	KV1471E	*HZ400020R
		D6	9322 154 46685	RB501V-40	*HZ200100R
		D665,D666	9965 000 06882	RB521S-30	*HZ200110R
		COILS			
NSP		L150,L330	—	LCYA100J2520	—
NSP		L304	—	LCYA2R7J2520	—
NSP		L81	—	VTL1067, CHIP COIL	—
		L85,L911	9965 000 07983	VTL1084, CHIP BEADS	*FC900240R
		CAPACITORS			
NSP		C123,C146,C613,C843	—	CCSRCH101J50	—
NSP		C322	—	CCSRCH120J50	—
NSP		C135	—	CCSRCH121J50	—
NSP		C104-C108	—	CCSRCH150J50	—
NSP		C206,C210,C211	—	CCSRCH151J50	—
NSP		C333	—	CCSRCH180J50	—
NSP		C116,C151,C314	—	CCSRCH220J50	—
NSP		C152	—	CCSRCH221J50	—
NSP		C127,C209,C337	—	CCSRCH331J50	—
NSP		C134,C236	—	CCSRCH470J50	—
NSP		C122,C208	—	CCSRCH471J50	—
NSP		C126,C335	—	CCSRCH560J50	—
NSP		C334	—	CCSRCH5R0C50	—
NSP		C124,C132	—	CCSRCH680J50	—
NSP		C117,C240,C352,C360	—	CCSRCH681J25	—
NSP		C845,C846	—	CCSRCK2R0C50	—
NSP		C129,C142,C842	—	CEV101M10	—
NSP	212	C827	—	CEV101M10	—
NSP		C113,C139	—	CEV220M16	—
NSP		C405,C413,C700,C808	—	CEV221M4	—
NSP		C111,C149,C205,C207,C401	—	CEV470M6R3	—
NSP		C403,C407	—	CEV470M6R3	—
NSP		C140,C223,C224,C252,C264	—	CKSQYB105K10	—
NSP		C312	—	CKSQYB105K10	—
NSP		C148,C217,C327,C414	—	CKSQYF105Z16	—
NSP		C801,C802,C807,C809-C815	—	CKSQYF105Z16	—
NSP		C817-C821	—	CKSQYF105Z16	—
NSP	212	C826,C828	—	CKSQYF105Z16	—
NSP		C216,C313	—	CKSRYB102K50	—
NSP		C133,C136,C203,C220,C225	—	CKSRYB103K50	—
NSP		C239,C320,C321,C603,C625	—	CKSRYB103K50	—
NSP		C703,C711	—	CKSRYB103K50	—
NSP		C101,C102,C114,C118,C119	—	CKSRYB104K16	—
NSP		C121,C138,C204,C212,C213	—	CKSRYB104K16	—
NSP		C227,C231,C263,C315,C317	—	CKSRYB104K16	—
NSP		C332,C804	—	CKSRYB104K16	—
NSP		C153,C266	—	CKSRYB223K25	—
NSP		C357	—	CKSRYB223K50	—
NSP		C354	—	CKSRYB332K50	—
NSP		C214,C251,C261,C351	—	CKSRYB472K50	—
NSP		C330	—	CKSRYB682K50	—
NSP		C109,C110,C120,C130,C131	—	CKSRYF104Z16	—
NSP		C143,C150,C202,C215	—	CKSRYF104Z16	—
NSP		C221,C222,C226,C230,C235	—	CKSRYF104Z16	—

Mark	Ver. (DB-VPBxxx)	No.	Part No. (for PCS)	Description	Part No. (for MJL)
NSP		C265,C299,C319,C359,C367	—	CKSRYF104Z16	—
NSP		C369,C370,C402,C404,C406	—	CKSRYF104Z16	—
NSP		C408,C410,C412,C601,C602	—	CKSRYF104Z16	—
NSP		C604-C612,C614,C615	—	CKSRYF104Z16	—
NSP		C617-C620,C626,C701,C702	—	CKSRYF104Z16	—
NSP		C704-C710,C712-C724,C726	—	CKSRYF104Z16	—
NSP		C831-C833,C844	—	CKSRYF104Z16	—
NSP	212	C822-C825,C829,C830	—	CKSRYF104Z16	—
NSP	212	C834-C836,C858,C859	—	CKSRYF104Z16	—
NSP		C368,C411 (47mF/16V)	—	VCH1166	—
RESISTORS					
NSP		R123 (39 OHM)	—	ACN7047	—
NSP		R732,R733,R735,R736 (47k OHM)	—	ACN7077	—
NSP		R632 (100OHM)	—	DCN1092	—
NSP		R608,R609,R613,R624,R627 (10k OHM)	—	DCN1094	—
NSP		R629,R631,R633,R638,R654 (10k OHM)	—	DCN1094	—
NSP		R657,R658,R664,R706 (10kOHM)	—	DCN1094	—
NSP		R717,R718 (10k OHM)	—	DCN1094	—
NSP		R121,R663 (10k OHM)	—	DCN1104	—
NSP		R712,R715,R881 (0 OHM)	—	DCN1106	—
NSP	212	R838 (0 OHM)	—	DCN1106	—
NSP		R1020,R2010,R2020, R2030,R2040	—	RS1/10S0R0J	—
NSP		R3050,R4010,R4020, R4030,R4040	—	RS1/10S0R0J	—
NSP		R4050,R4060,R407,R685,R722	—	RS1/10S0R0J	—
NSP		R8000,R821	—	RS1/10S0R0J	—
NSP	210,211,213,214	R501,R502,R801,R802,R828	—	RS1/10S0R0J	—
NSP	212	R803,R304,R829,R854 -R856,R858-R860	—	RS1/10S0R0J	—
NSP	212	R875,R920,R922,R970 -R973,R8010	—	RS1/10S0R0J	—
NSP	212	R8200	—	RS1/10S0R0J	—
NSP		R202,R3510	—	RS1/10S101J	—
NSP	212	R839	—	RS1/16S103J	—
NSP	210,211,213,214	R2	—	RS1/16S103J	—
NSP	212	R2	—	RS1/16S223J	—
NSP	212	R1	—	RS1/16S333J	—
NSP		R700	—	RS1/10S1R2J	—
NSP	212	R836,R837	—	RS1/16S1001F	—
NSP		R807	—	RS1/16S1201F	—
NSP	212	R831,R832	—	RS1/16S1201F	—
NSP		R806	—	RS1/16S1501F	—
NSP		R363,R365	—	RS1/16S1503F	—
NSP	212	R825	—	RS1/16S1800F	—
NSP	212	R834,R385	—	RS1/16S1801F	—
NSP	210,211,213,214	R825	—	RS1/16S2000F	—
NSP	212	R822-R824	—	RS1/16S2000F	—
NSP		R826,R827	—	RS1/16S2000F	—
NSP	212	R830	—	RS1/16S2002F	—
NSP		R805	—	RS1/16S2701F	—
NSP	212	R833	—	RS1/16S3902F	—
NSP		R361,R364	—	RS1/16S6202F	—
NSP		Other Resistors	—	RS1/16SxxxJ	—
OTHERS					
		CN4	9965 000 07984	DKN1193, FLEXIBLE CONNECTOR	*YJ002230R
		X2	9965 000 07985	DSS1110, CHIP CERALOCK (20MHz)	*FQ000450R
NSP		CN2	—	S2B-PH-SM3, PH CONNECTOR	—
NSP		CN1	—	S3B-PH-SM3, PH CONNECTOR	—
NSP		—	—	VDA1681, FLEXIBLE CABLE (07P)	—
NSP	210,212,213	CN15,CN5	—	VKN1516, CONNECTOR 30P	—
NSP	211,214	CN15,CN5	—	VKN1626, B TO B CONNECTOR 30P	—
NSP		CN3	—	VKN1763, 8P FFC CONNECTOR	—
NSP		—	—	VRW1773, BAR-CODE LABEL	—
NSP		X1	9965 000 07986	VSS1147, CRYSTAL RESONATOR (13.824MHz)	*JX000700R