

CIRCUIT BLOCK DIAGRAM

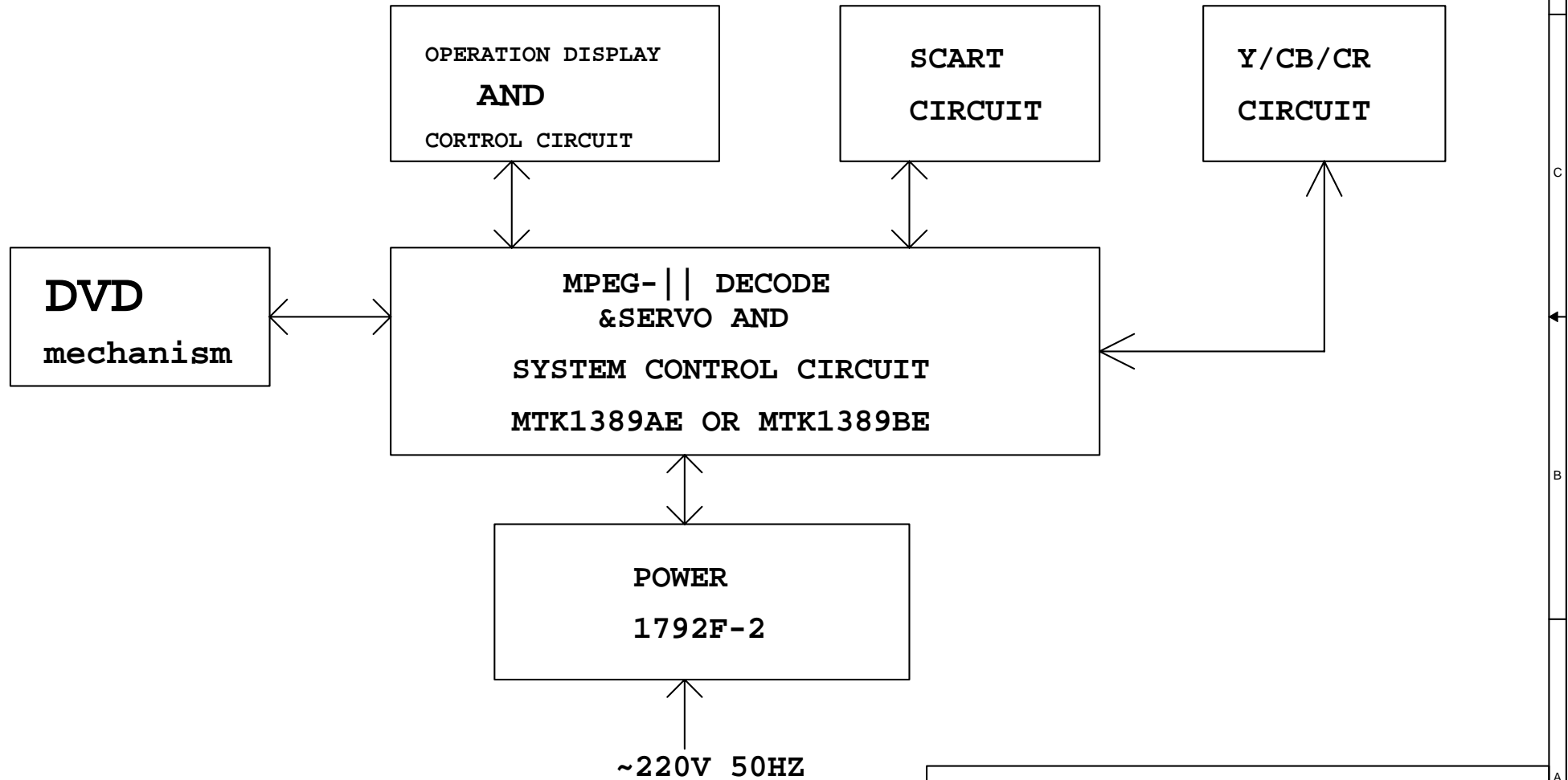

Title		
CIRCUIT BLOACK DIAGRAM		
Size	Document Number	Rev
A	<Doc>	1
Date:	Monday, March 22, 2004	Sheet 1 of 1

MT1389E (LQFP256) DVD Demo Board for Sanyo Slim HD60 PUH

- 1 INDEX & POWER, RESET
- 2 RF, SERVO & MPEG - MT1389E
- 3 MEMORY - SDRAM, FLASH/EEPROM
- 4 VIDEO OUT
- 5 AUDIO DAC WMA8746&WMA8720 AND AUDIO OUT

Rev	History	P#	Date
V1	The original released.		2003.6.15
V2	Change CE11 from 10uF to 100uF Change C3 from C to 220pF Change C1 from 0.1uF to C Change R10,R15 from 750k to 480k Change R17,R19 from 390k to 150k Add C74 2200pF Change R37 from 0 to R Change R38 from 0 to R Change C32 from 15nF to C Change PIN 47 from LIMIT to ADIN Add CE1 10uF Change R15 from 1.5k to 1.8k Remove 74H01 Change the LIMIT signal from PIN 46 to PIN136 Change R4,R5,R6,R9,R12 from 1k to R Change the TRINTERRUPT pullup power from 5V to 3V3 Add IC pinout Change R7 from 0 to 10K Add the low resistance output circuit Change spdif output port Add the Audio DAC power to reference filtering Change The Video output circuit		2003.7.17
			2003.9.16

NAME	TYPE	DEVICE
VCC	Digital 5V	SUPPLY
DV33	Digital 3.3V	MT1389E
RFV33	Servo 3.3V	MT1389E
LDO_AV33	Laser Diode 3.3V	
AVCC	RF 5V	PICKUP HEADER
V18	Digital 1.8V	MT1389E
SD33	Digital 3.3V	SDRAM
+12V	Audio +12V	OP AMP.
-12V	Audio -12V	OP AMP.
AVDD	Audio 5V	Audio DAC
DVDD	Audio 5V	Audio DAC

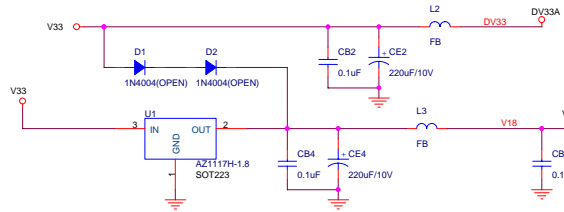
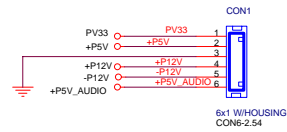

Power ON alive source

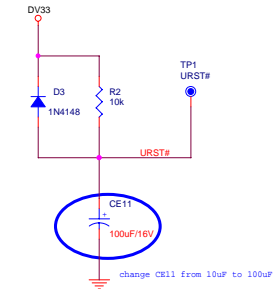
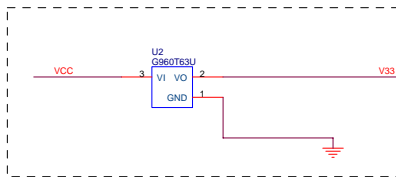
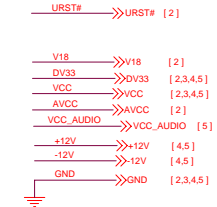
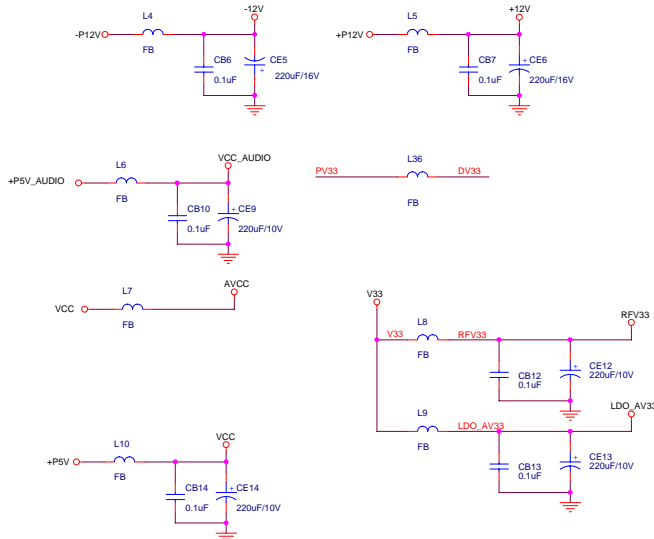

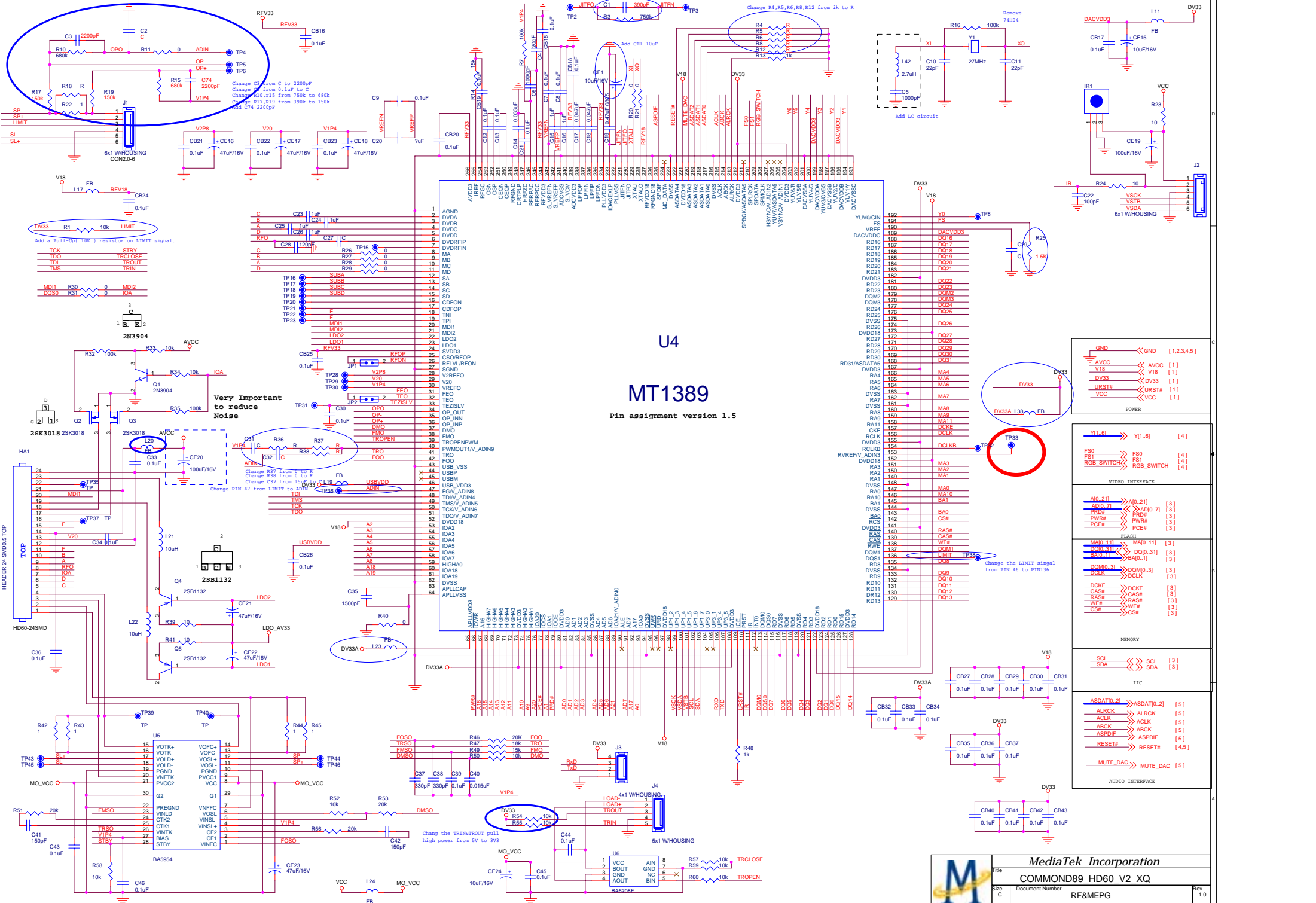

U4
MT1389
Pin assignment version 1.5

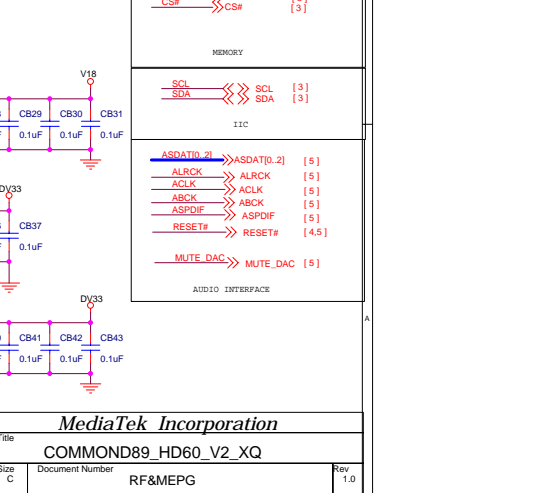
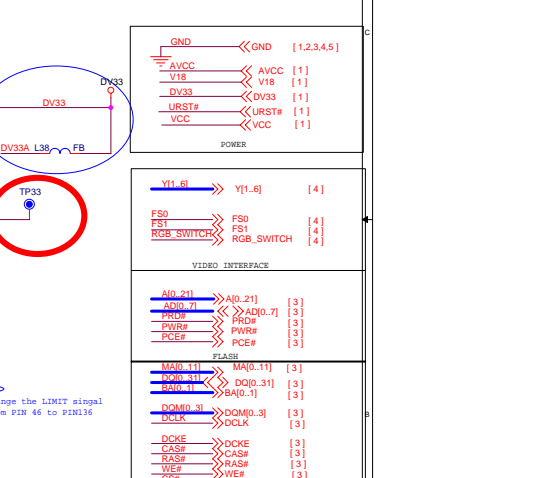
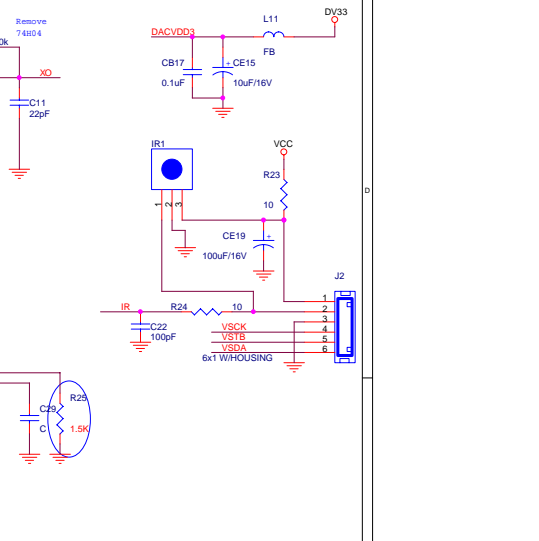
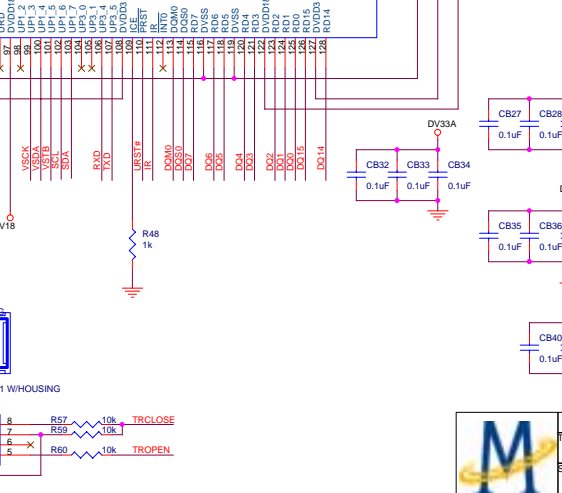
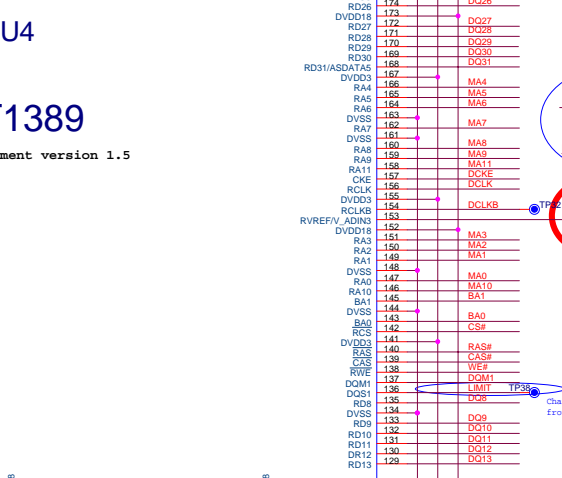
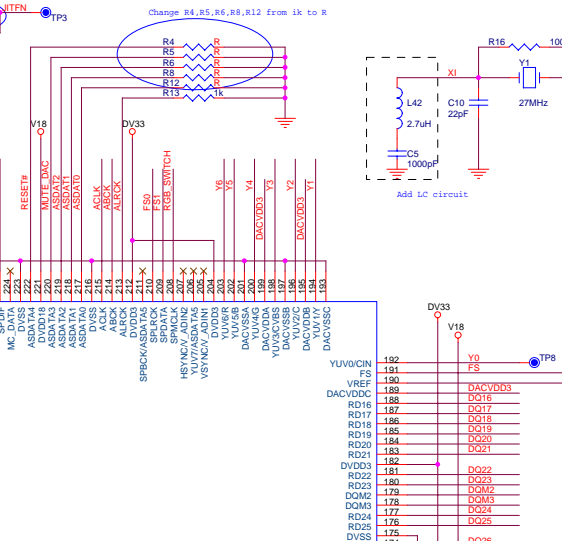
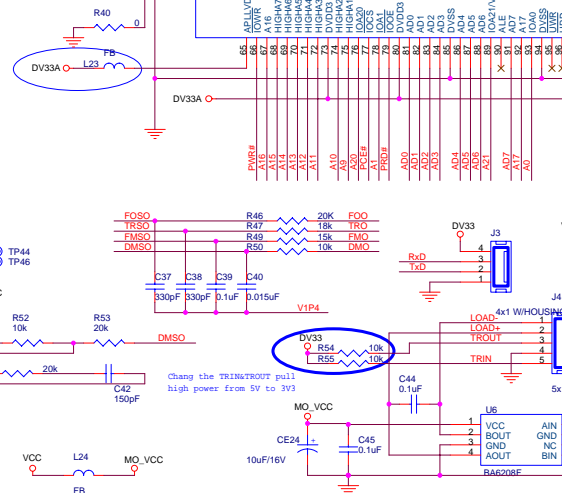
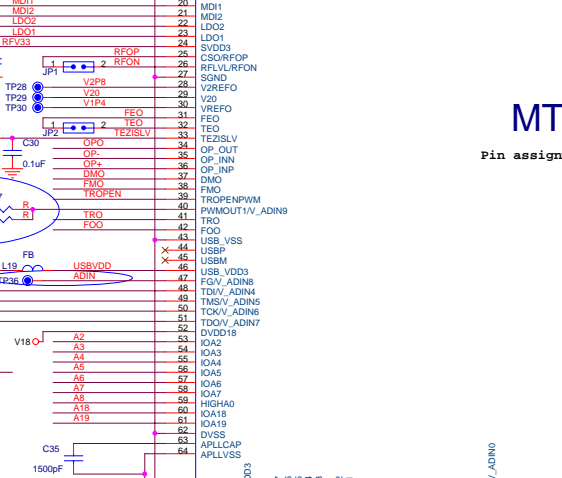
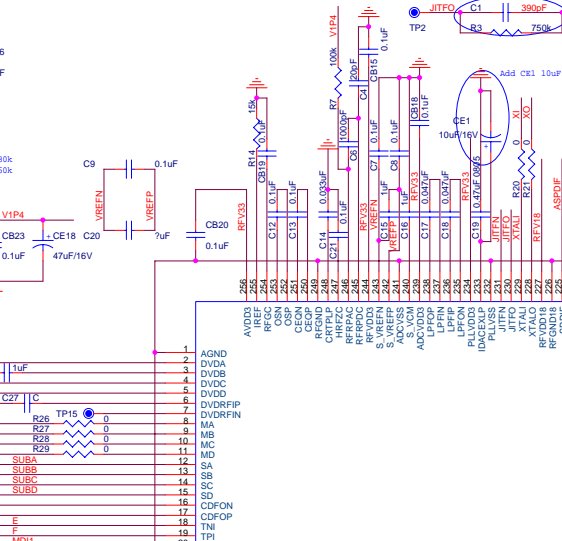
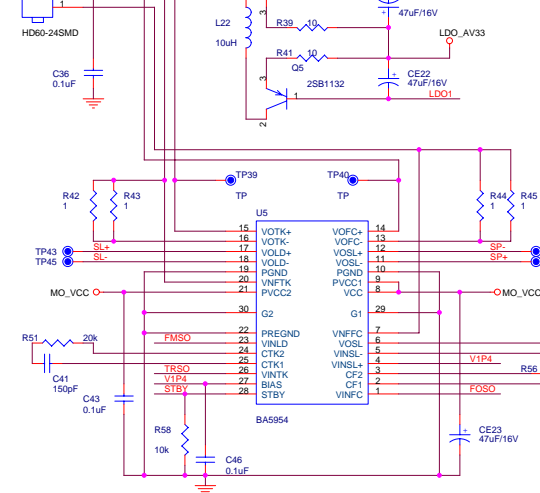
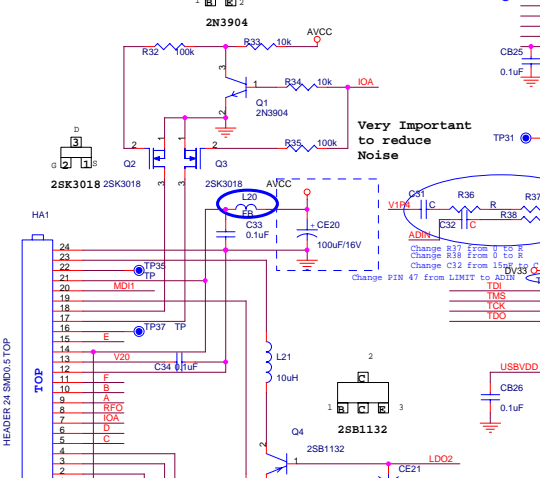
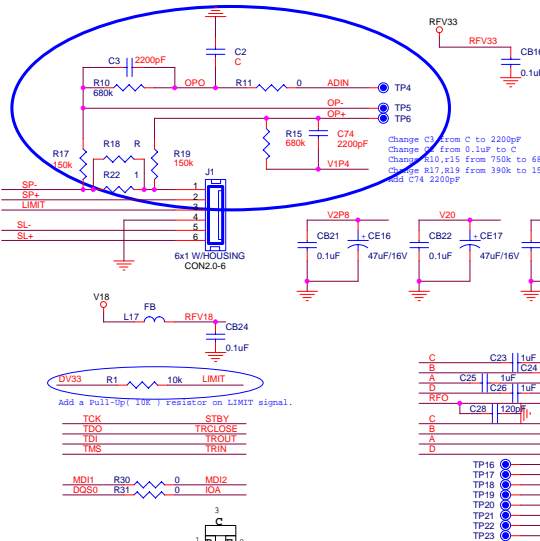

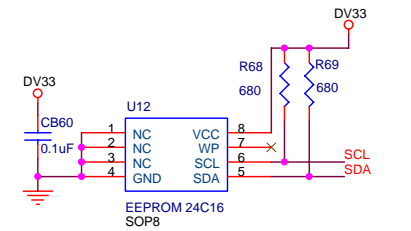
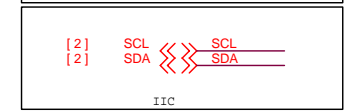
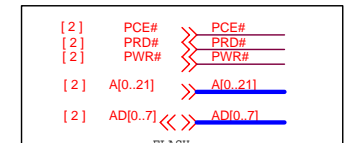
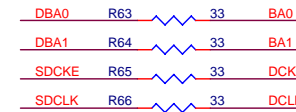
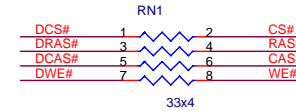
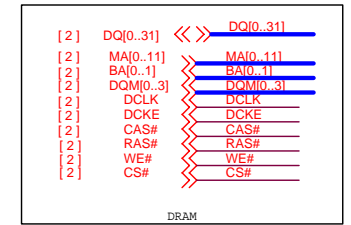
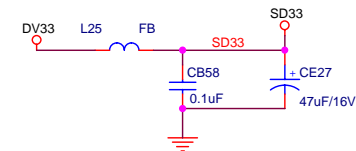
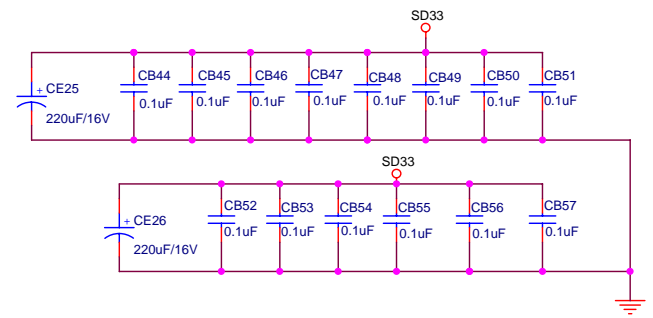
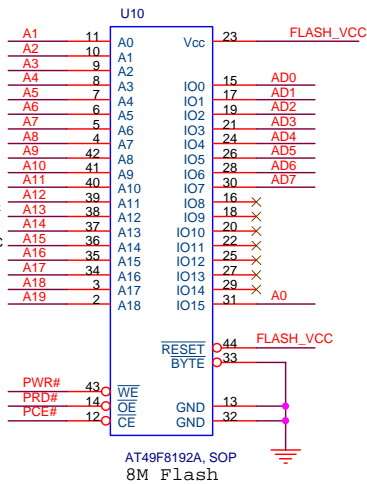
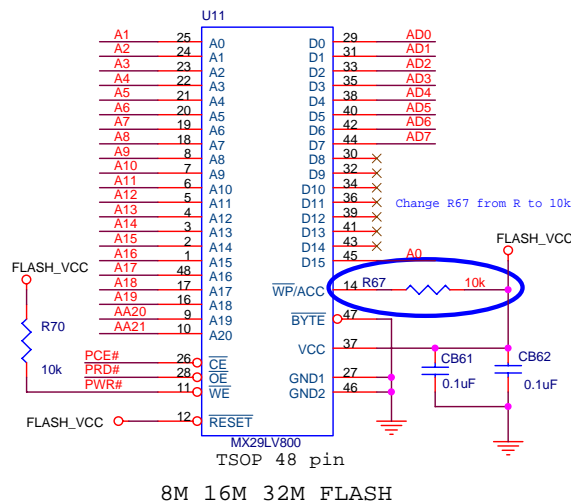
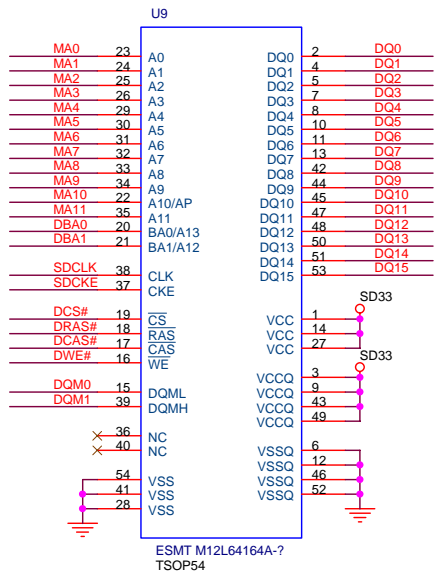
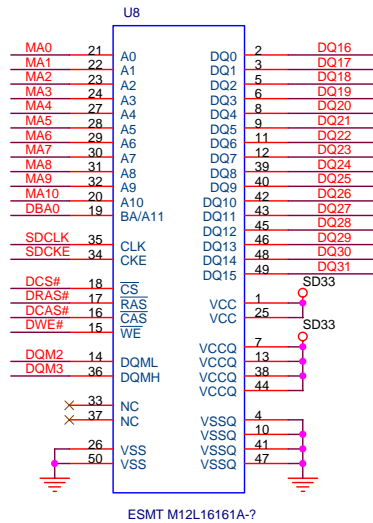
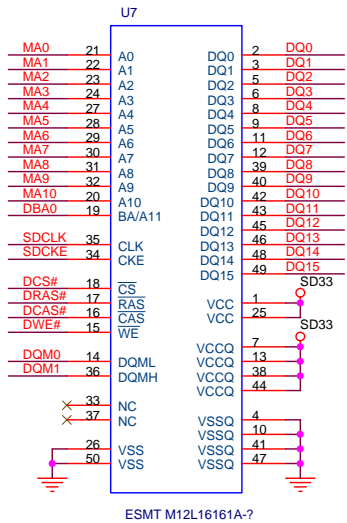

	MediaTek Incorporation	
	Title: COMMOND89_HD60_V2_XQ	
Size: B	Document Number: SDRAM&FLASH	Rev: 1.0
Date: Friday, September 19, 2003	Sheet: 3	of 5

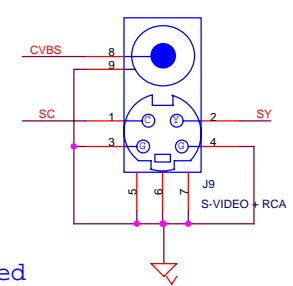
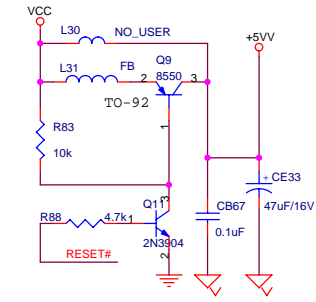
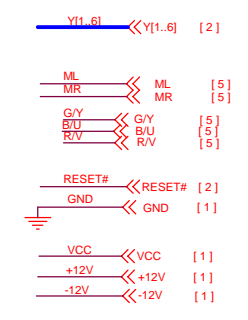
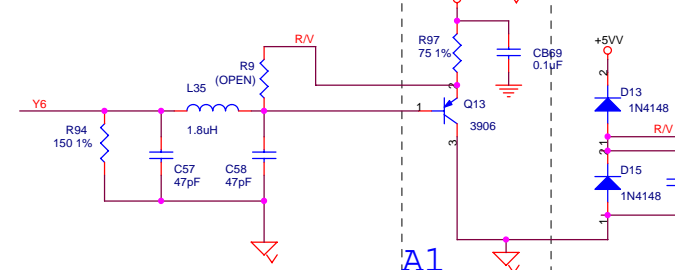
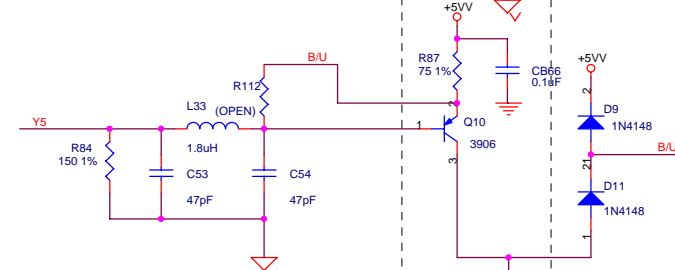
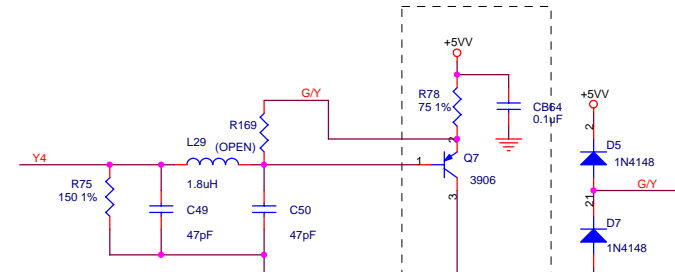
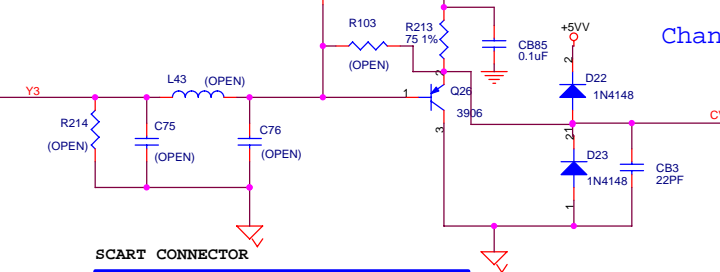
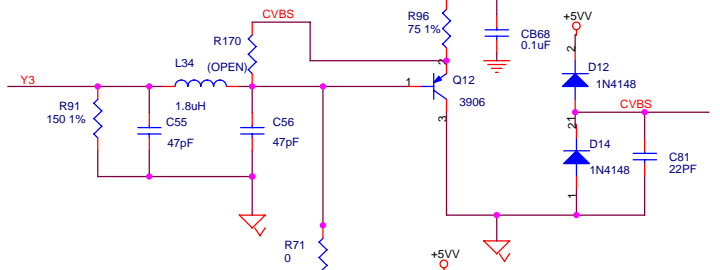
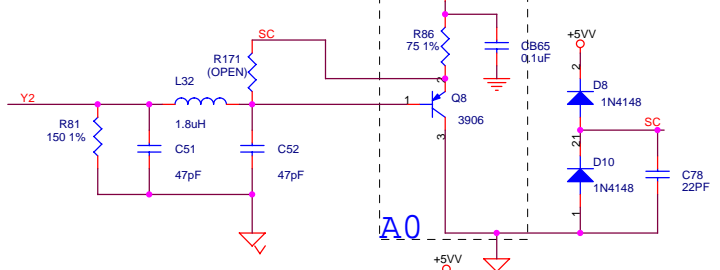
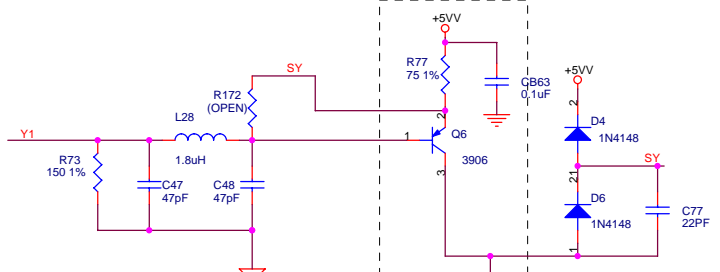

Change The Video Output Circuit. And The A0&A1 must be removed

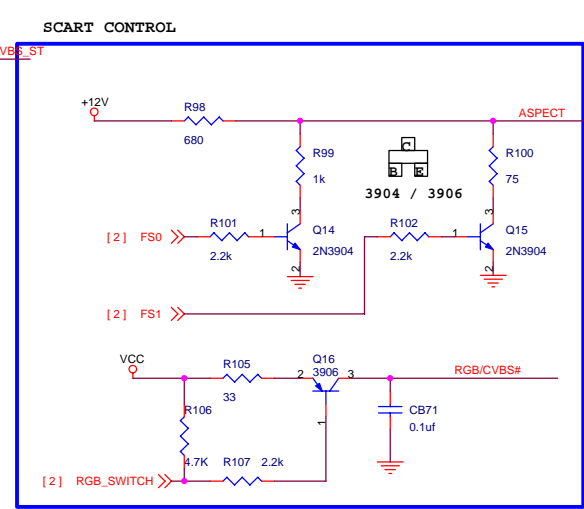
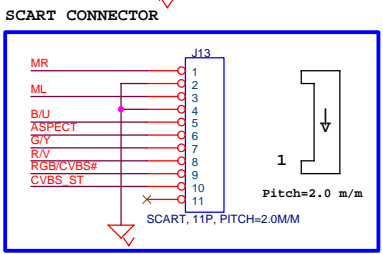

Y Cb Cr CONNECTOR

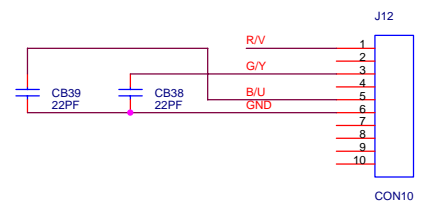

- [1] -12V
- [1] +12V
- [1] DV33
- [1] VCC
- [1] VCC_AUDIO
- [1,2,3,5] GND

- [2] ASPDIF
- [2] ASDAT[0..2]
- [2] ACLK
- [2] ABCK
- [2] ALRCK

- [2] MUTE_DAC
- [2] RESET#
- [4] ML
- [4] MR

- ACLK R138
- ALRCK R139
- ABCK R142
- ASDAT0 R143
- ASDAT1 R144
- ASDAT2 R145
- SACLK 33
- SLRCK 33
- SBRCK 33
- SDAT0 33
- SDAT1 33
- SDAT2 33

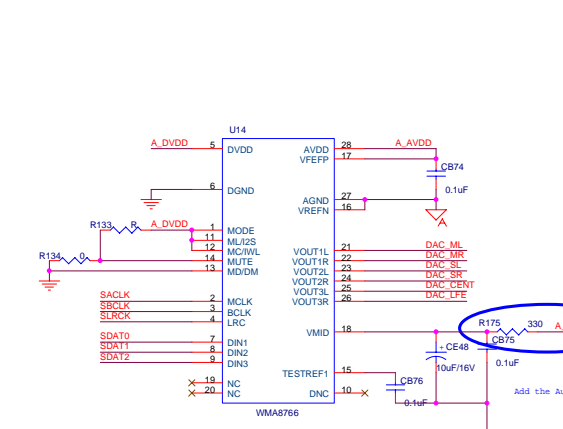
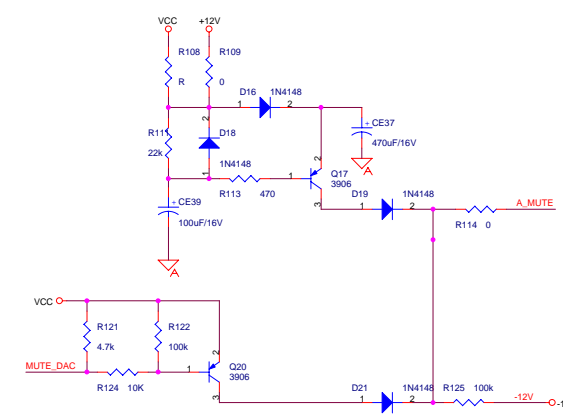

HARDWARE: IIS 24BIT

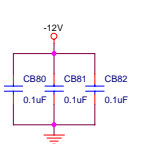
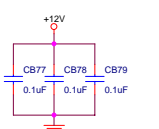
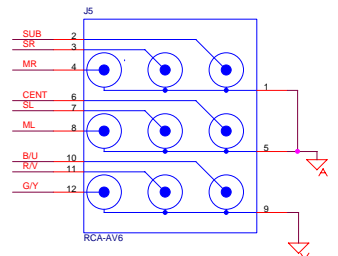
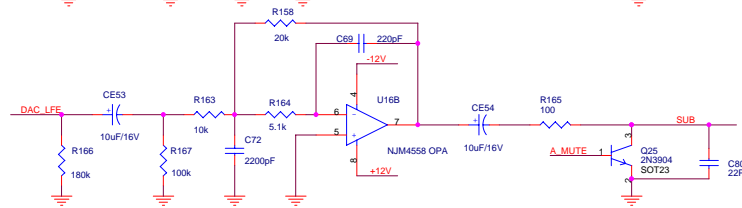
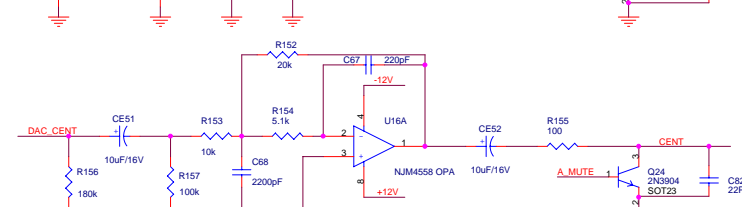
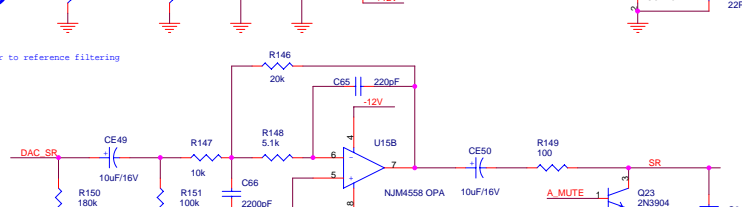
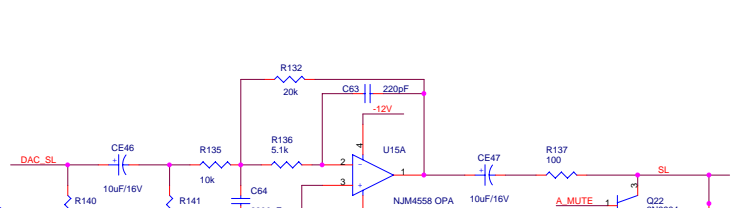
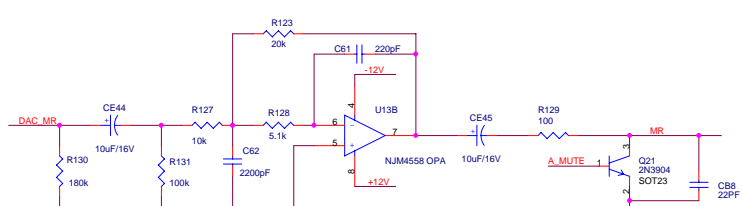
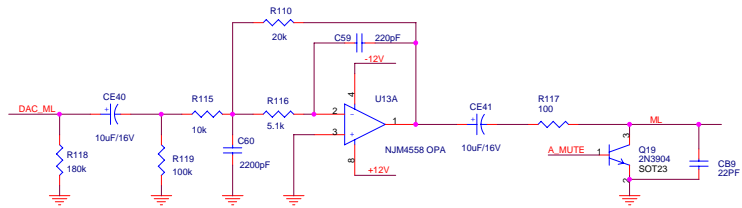
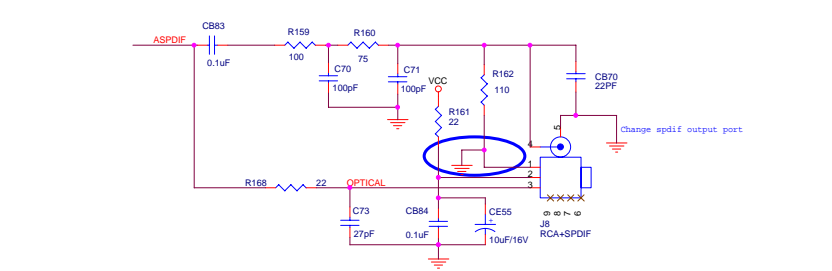
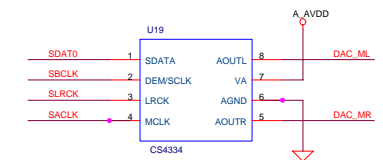

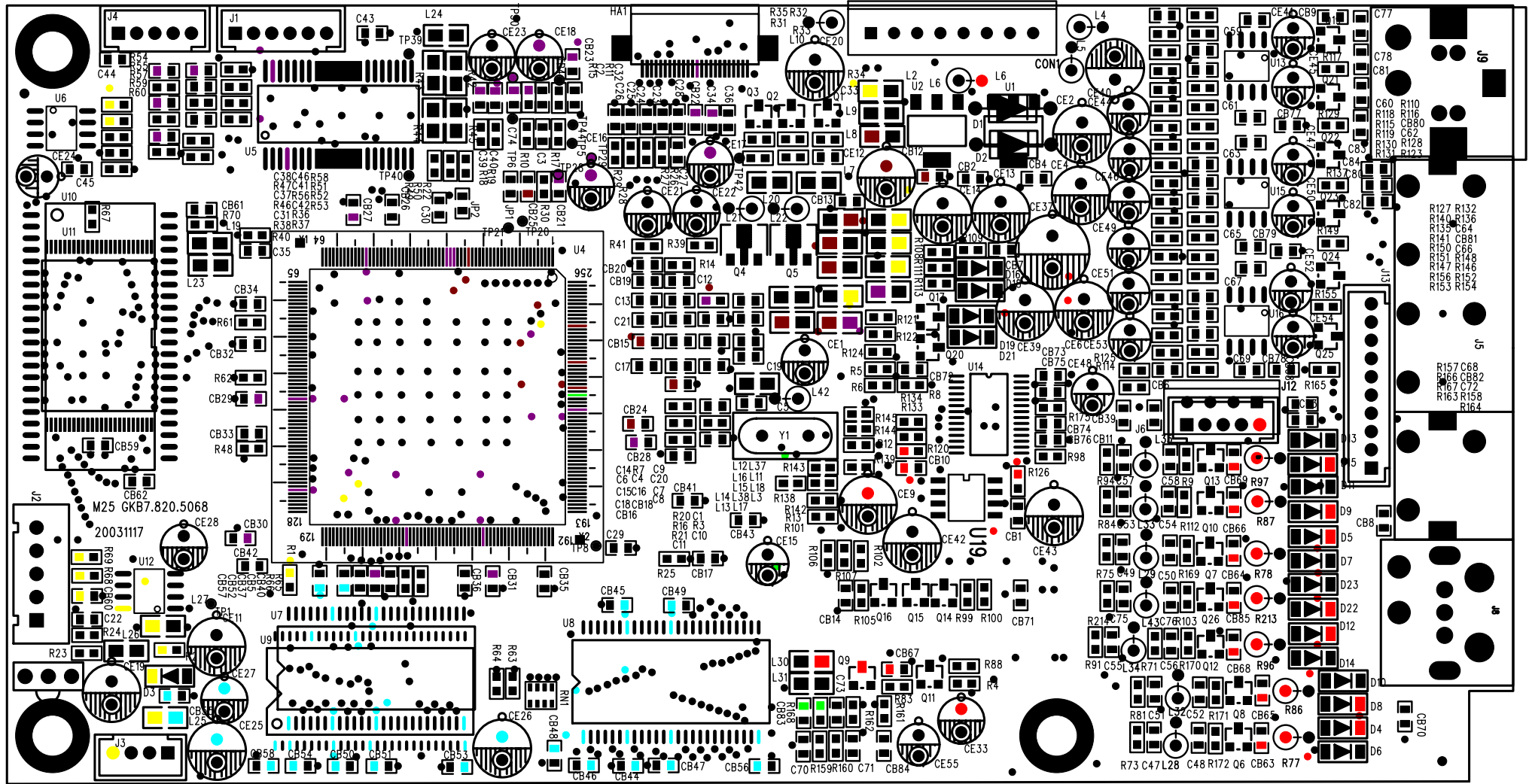

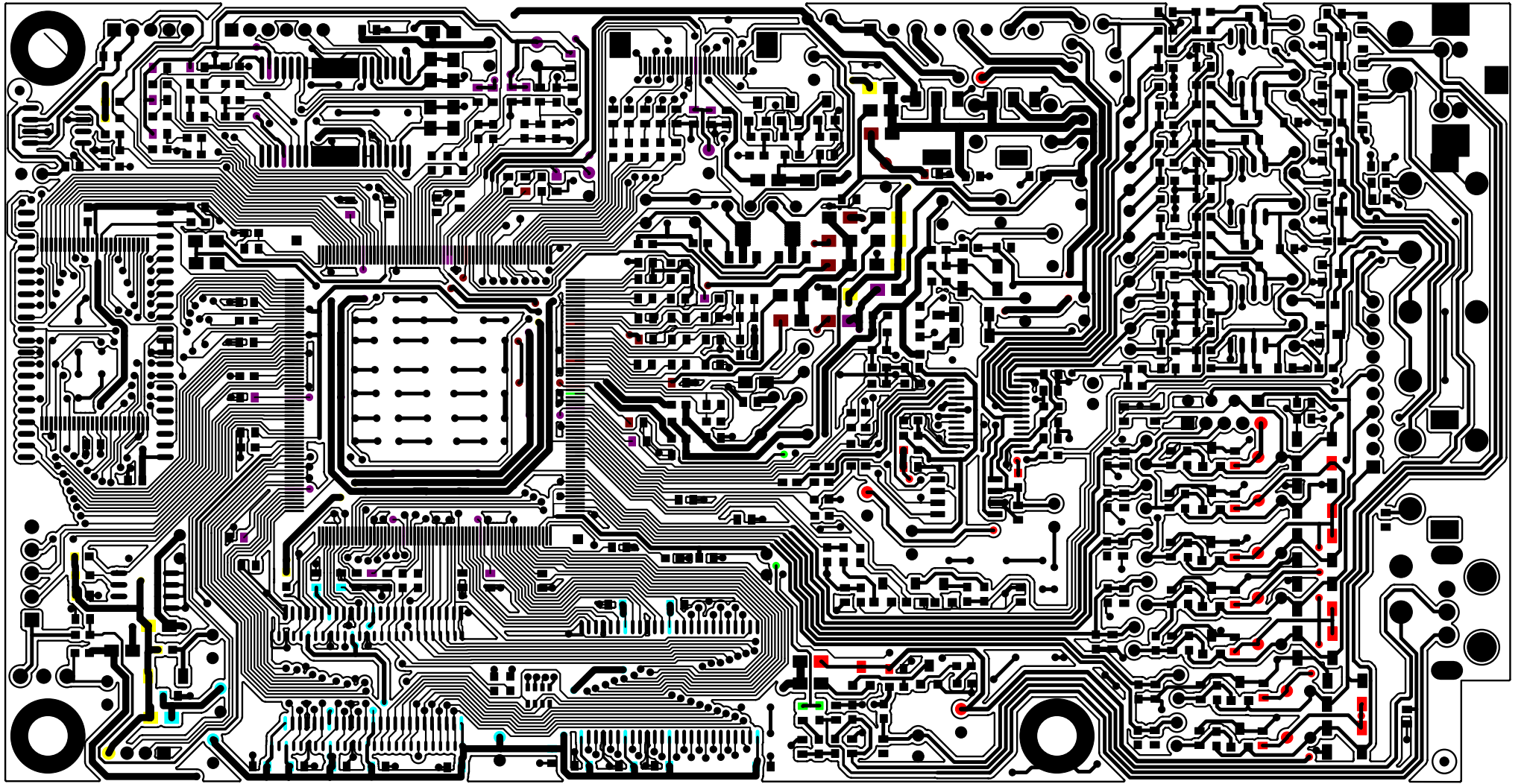

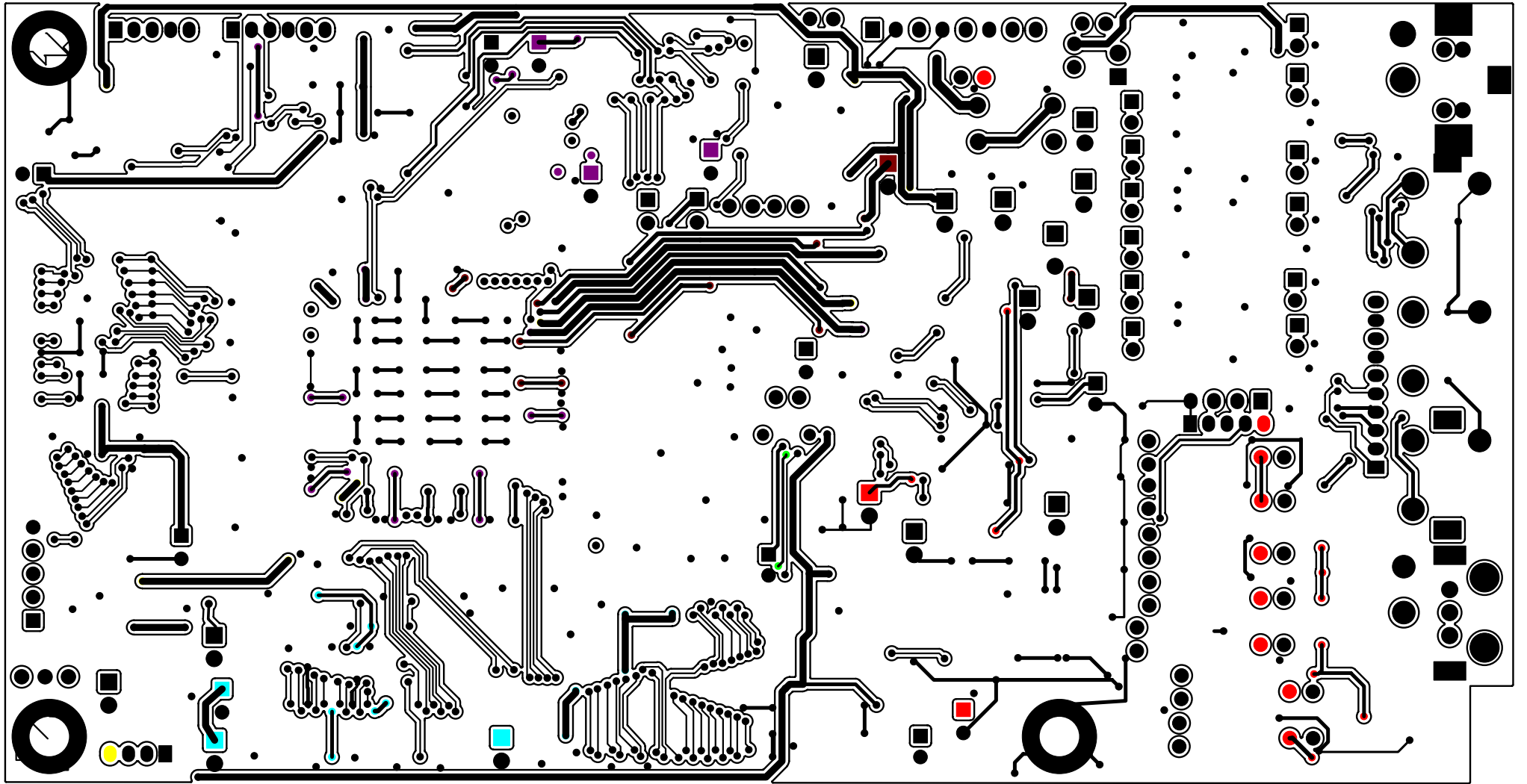

CAPACITOR			
C1	CC41-B-390P-50V ± 10%	C83	CC41-CG-22P-50V ± 10%
C3	CC41-B-2200P-50V ± 10%	C84	CC41-CG-22P-50V ± 10%
C4	CC41-CG-20P-50V ± 10%	CB2	CC41-Y5V-0.1u-50V ± 10%
C5	CC41-B-1000P-50V ± 10%	CB3	CC41-CG-22P-50V ± 10%
C6	CC41-B-1000P-50V ± 10%	CB4	CC41-Y5V-0.1u-50V ± 10%
C7	CC41-Y5V-0.1u-50V ± 10%	CB5	CC41-Y5V-0.1u-50V ± 10%
C8	CC41-Y5V-0.1u-50V ± 10%	CB6	CC41-Y5V-0.1u-50V ± 10%
C9	CC41-Y5V-0.1u-50V ± 10%	CB7	CC41-Y5V-0.1u-50V ± 10%
C10	CC41-CG-22P-50V ± 10%	CB8	CC41-CG-22P-50V ± 10%
C11	CC41-CG-22P-50V ± 10%	CB9	CC41-CG-22P-50V ± 10%
C12	CC41-Y5V-0.1u-50V ± 10%	CB10	CC41-Y5V-0.1u-50V ± 10%
C13	CC41-Y5V-0.1u-50V ± 10%	CB11	CC41-CG-22P-50V ± 10%
C14	CC41-Y5V-0.033u-50V ± 10%	CB12	CC41-Y5V-0.1u-50V ± 10%
C15	CC41-Y5V-1u-50V ± 10%	CB13	CC41-Y5V-0.1u-50V ± 10%
C16	CC41-Y5V-1u-50V ± 10%	CB14	CC41-Y5V-0.1u-50V ± 10%
C17	CC41-Y5V-0.047u-50V ± 10%	CB15	CC41-Y5V-0.1u-50V ± 10%
C18	CC41-Y5V-0.047u-50V ± 10%	CB16	CC41-Y5V-0.1u-50V ± 10%
C19	CC41-Y5V-0.47u-50V ± 10%	CB17	CC41-Y5V-0.1u-50V ± 10%
C21	CC41-Y5V-0.1u-50V ± 10%	CB18	CC41-Y5V-0.1u-50V ± 10%
C22	CC41-CG-100P-50V ± 10%	CB19	CC41-Y5V-0.1u-50V ± 10%
C23	CC41-Y5V-1u-50V ± 10%	CB20	CC41-Y5V-0.1u-50V ± 10%
C24	CC41-Y5V-1u-50V ± 10%	CB21	CC41-Y5V-0.1u-50V ± 10%
C25	CC41-Y5V-1u-50V ± 10%	CB22	CC41-Y5V-0.1u-50V ± 10%
C26	CC41-Y5V-1u-50V ± 10%	CB23	CC41-Y5V-0.1u-50V ± 10%
C28	CC41-CG-120P-50V ± 10%	CB24	CC41-Y5V-0.1u-50V ± 10%
C30	CC41-Y5V-0.1u-50V ± 10%	CB25	CC41-Y5V-0.1u-50V ± 10%
C33	CC41-Y5V-0.1u-50V ± 10%	CB26	CC41-Y5V-0.1u-50V ± 10%
C34	CC41-Y5V-0.1u-50V ± 10%	CB27	CC41-Y5V-0.1u-50V ± 10%
C35	CC41-B-1500P-50V ± 10%	CB28	CC41-Y5V-0.1u-50V ± 10%
C36	CC41-Y5V-0.1u-50V ± 10%	CB29	CC41-Y5V-0.1u-50V ± 10%
C37	CC41-B-330P-50V ± 10%	CB30	CC41-Y5V-0.1u-50V ± 10%
C38	CC41-B-330P-50V ± 10%	CB31	CC41-Y5V-0.1u-50V ± 10%
C39	CC41-Y5V-0.1u-50V ± 10%	CB32	CC41-Y5V-0.1u-50V ± 10%
C40	CC41-Y5V-0.015u-50V ± 10%	CB33	CC41-Y5V-0.1u-50V ± 10%
C41	CC41-CG-150P-50V ± 10%	CB34	CC41-Y5V-0.1u-50V ± 10%
C42	CC41-CG-150P-50V ± 10%	CB35	CC41-Y5V-0.1u-50V ± 10%
C43	CC41-Y5V-0.1u-50V ± 10%	CB36	CC41-Y5V-0.1u-50V ± 10%
C44	CC41-Y5V-0.1u-50V ± 10%	CB37	CC41-Y5V-0.1u-50V ± 10%
C45	CC41-Y5V-0.1u-50V ± 10%	CB38	CC41-CG-22P-50V ± 10%
C46	CC41-Y5V-0.1u-50V ± 10%	CB39	CC41-CG-22P-50V ± 10%
C47	CC41-CG-47P-50V ± 10%	CB40	CC41-Y5V-0.1u-50V ± 10%
C48	CC41-CG-47P-50V ± 10%	CB41	CC41-Y5V-0.1u-50V ± 10%
C49	CC41-CG-47P-50V ± 10%	CB42	CC41-Y5V-0.1u-50V ± 10%
C50	CC41-CG-47P-50V ± 10%	CB43	CC41-Y5V-0.1u-50V ± 10%
C51	CC41-CG-47P-50V ± 10%	CB44	CC41-Y5V-0.1u-50V ± 10%
C52	CC41-CG-47P-50V ± 10%	CB45	CC41-Y5V-0.1u-50V ± 10%
C53	CC41-CG-47P-50V ± 10%	CB46	CC41-Y5V-0.1u-50V ± 10%
C54	CC41-CG-47P-50V ± 10%	CB47	CC41-Y5V-0.1u-50V ± 10%
C55	CC41-CG-47P-50V ± 10%	CB48	CC41-Y5V-0.1u-50V ± 10%
C56	CC41-CG-47P-50V ± 10%	CB49	CC41-Y5V-0.1u-50V ± 10%
C57	CC41-CG-47P-50V ± 10%	CB50	CC41-Y5V-0.1u-50V ± 10%
C58	CC41-CG-47P-50V ± 10%	CB51	CC41-Y5V-0.1u-50V ± 10%
C59	CC41-B-220P-50V ± 10%	CB52	CC41-Y5V-0.1u-50V ± 10%
C60	CC41-B-220P-50V ± 10%	CB53	CC41-Y5V-0.1u-50V ± 10%
C61	CC41-B-220P-50V ± 10%	CB54	CC41-Y5V-0.1u-50V ± 10%
C62	CC41-B-220P-50V ± 10%	CB55	CC41-Y5V-0.1u-50V ± 10%
C63	CC41-B-220P-50V ± 10%	CB56	CC41-Y5V-0.1u-50V ± 10%
C64	CC41-B-220P-50V ± 10%	CB57	CC41-Y5V-0.1u-50V ± 10%
C65	CC41-B-220P-50V ± 10%	CB58	CC41-Y5V-0.1u-50V ± 10%
C66	CC41-B-220P-50V ± 10%	CB59	CC41-Y5V-0.1u-50V ± 10%
C67	CC41-B-220P-50V ± 10%	CB60	CC41-Y5V-0.1u-50V ± 10%
C68	CC41-B-220P-50V ± 10%	CB61	CC41-Y5V-0.1u-50V ± 10%
C69	CC41-B-220P-50V ± 10%	CB62	CC41-Y5V-0.1u-50V ± 10%
C70	CC41-CG-100P-50V ± 10%	CB63	CC41-Y5V-0.1u-50V ± 10%
C71	CC41-CG-100P-50V ± 10%	CB64	CC41-Y5V-0.1u-50V ± 10%
C72	CC41-B-2200P-50V ± 10%	CB65	CC41-Y5V-0.1u-50V ± 10%
C73	CC41-CG-27P-50V ± 10%	CB66	CC41-Y5V-0.1u-50V ± 10%
C74	CC41-B-2200P-50V ± 10%	CB67	CC41-Y5V-0.1u-50V ± 10%
C77	CC41-CG-22P-50V ± 10%	CB68	CC41-Y5V-0.1u-50V ± 10%
C78	CC41-CG-22P-50V ± 10%	CB69	CC41-Y5V-0.1u-50V ± 10%
C80	CC41-CG-22P-50V ± 10%	CB70	CC41-CG-22P-50V ± 10%
C81	CC41-CG-22P-50V ± 10%	CB71	CC41-Y5V-0.1u-50V ± 10%
C82	CC41-CG-22P-50V ± 10%	CB72	CC41-Y5V-0.1u-50V ± 10%
CB73	CC41-Y5V-0.1u-50V ± 10%	CB80	CC41-Y5V-0.1u-50V ± 10%
CB74	CC41-Y5V-0.1u-50V ± 10%	CB81	CC41-Y5V-0.1u-50V ± 10%
CB75	CC41-Y5V-0.1u-50V ± 10%	CB82	CC41-Y5V-0.1u-50V ± 10%
CB76	CC41-Y5V-0.1u-50V ± 10%	CB83	CC41-Y5V-0.1u-50V ± 10%
CB77	CC41-Y5V-0.1u-50V ± 10%	CB84	CC41-Y5V-0.1u-50V ± 10%

CB78	CC41-Y5V-0. 1u-50V ± 10%	CB85	CC41-Y5V-0. 1u-50V ± 10%
CB79	CC41-Y5V-0. 1u-50V ± 10%		
CE1	CD11X-16V-10 μ F ± 20%	CE27	CD11X-16V-47 μ F ± 20%
CE2	CD11X-10V-220 μ F ± 20%	CE28	CD11X-16V-47 μ F ± 20%
CE4	CD11X-10V-220 μ F ± 20%	CE33	CD11X-16V-47 μ F ± 20%
CE5	CD11X-16V-220 μ F ± 20%	CE37	CD11X-10V-470 μ F ± 20%
CE6	CD11X-16V-220 μ F ± 20%	CE39	CD11X-16V-100 μ F ± 20%
CE9	CD11X-10V-220 μ F ± 20%	CE40	CD11X-16V-10 μ F ± 20%
CE11	CD11X-16V-100 μ F ± 20%	CE41	CD11X-16V-10 μ F ± 20%
CE12	CD11X-10V-220 μ F ± 20%	CE42	CD11X-16V-100 μ F ± 20%
CE13	CD11X-10V-220 μ F ± 20%	CE43	CD11X-16V-100 μ F ± 20%
CE14	CD11X-10V-220 μ F ± 20%	CE44	CD11X-16V-10 μ F ± 20%
CE15	CD11X-16V-10 μ F ± 20%	CE45	CD11X-16V-10 μ F ± 20%
CE16	CD11X-16V-47 μ F ± 20%	CE46	CD11X-16V-10 μ F ± 20%
CE17	CD11X-16V-47 μ F ± 20%	CE47	CD11X-16V-10 μ F ± 20%
CE18	CD11X-16V-47 μ F ± 20%	CE48	CD11X-16V-10 μ F ± 20%
CE19	CD11X-16V-100 μ F ± 20%	CE49	CD11X-16V-10 μ F ± 20%
CE20	CD11X-16V-100 μ F ± 20%	CE50	CD11X-16V-10 μ F ± 20%
CE21	CD11X-16V-47 μ F ± 20%	CE51	CD11X-16V-10 μ F ± 20%
CE22	CD11X-16V-47 μ F ± 20%	CE52	CD11X-16V-10 μ F ± 20%
CE23	CD11X-16V-47 μ F ± 20%	CE53	CD11X-16V-10 μ F ± 20%
CE24	CD11X-16V-10 μ F ± 20%	CE54	CD11X-16V-10 μ F ± 20%
CE25	CD11X-16V-220 μ F ± 20%	CE55	CD11X-16V-10 μ F ± 20%
CE26	CD11X-16V-220 μ F ± 20%		
RESISTOR			
R1	RC-03-10k ± 5%	R53	RC-03-20k ± 5%
R2	RC-03-10k ± 5%	R54	RC-03-10k ± 5%
R3	RC-03-750k ± 5%	R55	RC-03-10k ± 5%
R7	RC-03-100k ± 5%	R56	RC-03-20k ± 5%
R10	RC-03-680k ± 5%	R57	RC-03-10k ± 5%
R11	RC-03-0 ± 5%	R58	RC-03-10k ± 5%
R13	RC-03-1k ± 5%	R59	RC-03-10k ± 5%
R14	RC-03-15k ± 5%	R60	RC-03-10k ± 5%
R15	RC-03-680k ± 5%	R63	RC-03-33 ± 5%
R16	RC-03-100k ± 5%	R64	RC-03-33 ± 5%
R17	RC-03-150k ± 5%	R65	RC-03-33 ± 5%
R19	RC-03-150k ± 5%	R66	RC-03-33 ± 5%
R20	RC-03-0 ± 5%	R67	RC-03-10k ± 5%
R21	RC-03-0 ± 5%	R68	RC-03-680 ± 5%
R22	RC-05-1 ± 5%	R69	RC-03-680 ± 5%
R23	RC-03-10 ± 5%	R70	RC-03-10k ± 5%
R24	RC-03-10 ± 5%	R71	RC-03-0 ± 5%
R25	RC-03-2k ± 5%	R73	RC-03-150 ± 5%
R26	RC-03-0 ± 5%	R75	RC-03-150 ± 5%
R27	RC-03-0 ± 5%	R77	RT14-1/4W-75 ± 1%
R28	RC-03-0 ± 5%	R78	RT14-1/4W-75 ± 1%
R29	RC-03-0 ± 5%	R81	RC-03-150 ± 5%
R30	RC-03-0 ± 5%	R83	RC-03-10k ± 5%
R31	RC-03-0 ± 5%	R84	RC-03-150 ± 5%
R32	RC-03-100k ± 5%	R86	RT14-1/4W-75 ± 1%
R33	RC-03-10k ± 5%	R87	RT14-1/4W-75 ± 1%
R34	RC-03-10k ± 5%	R88	RC-03-4. 7k ± 5%
R35	RC-03-100k ± 5%	R91	RC-03-150 ± 5%
R39	RC-03-10 ± 5%	R94	RC-03-150 ± 5%
R40	RC-03-0 ± 5%	R96	RT14-1/4W-75 ± 1%
R41	RC-03-10 ± 5%	R97	RT14-1/4W-75 ± 1%
R42	RC-05-1 ± 5%	R98	RC-03-680 ± 5%
R43	RC-05-1 ± 5%	R99	RC-03-1k ± 5%
R44	RC-05-1 ± 5%	R100	RC-03-75 ± 5%
R45	RC-05-1 ± 5%	R101	RC-03-2. 2k ± 5%
R46	RC-03-20k ± 5%	R102	RC-03-2. 2k ± 5%
R47	RC-03-18k ± 5%	R105	RC-03-33 ± 5%
R48	RC-03-1k ± 5%	R106	RC-03-4. 7k ± 5%
R49	RC-03-15k ± 5%	R107	RC-03-2. 2k ± 5%
R50	RC-03-10k ± 5%	R109	RC-03-0 ± 5%
R51	RC-03-20k ± 5%	R110	RC-03-20k ± 5%
R52	RC-03-10k ± 5%	R111	RC-03-22k ± 5%
R113	RC-03-470 ± 5%	R142	RC-03-33 ± 5%
R114	RC-03-0 ± 5%	R143	RC-03-33 ± 5%
R115	RC-03-10k ± 5%	R144	RC-03-33 ± 5%
R116	RC-03-5. 1k ± 5%	R145	RC-03-33 ± 5%
R117	RC-03-100 ± 5%	R146	RC-03-20k ± 5%
R118	RC-03-180k ± 5%	R147	RC-03-10k ± 5%
R119	RC-03-100k ± 5%	R148	RC-03-5. 1k ± 5%
R120	RC-05-100 ± 5%	R149	RC-03-100 ± 5%
R121	RC-03-4. 7k ± 5%	R150	RC-03-180k ± 5%
R122	RC-03-100k ± 5%	R151	RC-03-100k ± 5%

R123	RC-03-20k ± 5%	R152	RC-03-20k ± 5%
R124	RC-03-10k ± 5%	R153	RC-03-10k ± 5%
R125	RC-03-100k ± 5%	R154	RC-03-5. 1k ± 5%
R126	RC-05-0 ± 5%	R155	RC-03-100 ± 5%
R127	RC-03-10k ± 5%	R156	RC-03-180k ± 5%
R128	RC-03-5. 1k ± 5%	R157	RC-03-100k ± 5%
R129	RC-03-100 ± 5%	R158	RC-03-20k ± 5%
R130	RC-03-180k ± 5%	R159	RC-03-100 ± 5%
R131	RC-03-100k ± 5%	R160	RC-03-75 ± 5%
R132	RC-03-20k ± 5%	R161	RC-03-22 ± 5%
R134	RC-03-0 ± 5%	R162	RC-03-100 ± 5%
R135	RC-03-10k ± 5%	R163	RC-03-10k ± 5%
R136	RC-03-5. 1k ± 5%	R164	RC-03-5. 1k ± 5%
R137	RC-03-100 ± 5%	R165	RC-03-100 ± 5%
R138	RC-03-33 ± 5%	R166	RC-03-180k ± 5%
R139	RC-03-33 ± 5%	R167	RC-03-100k ± 5%
R140	RC-03-180k ± 5%	R168	RC-03-22 ± 5%
R141	RC-03-100k ± 5%	R213	RT14-1/4W-75 ± 1%
RESISTOR ARRAY			
RN1	33R OHM × 4		
DIODE			
D3	1N4148 (SMT)	D13	1N4148 (SMT)
D4	1N4148 (SMT)	D14	1N4148 (SMT)
D5	1N4148 (SMT)	D15	1N4148 (SMT)
D6	1N4148 (SMT)	D16	1N4148 (SMT)
D7	1N4148 (SMT)	D18	1N4148 (SMT)
D8	1N4148 (SMT)	D19	1N4148 (SMT)
D9	1N4148 (SMT)	D21	1N4148 (SMT)
D10	1N4148 (SMT)	D22	1N4148 (SMT)
D11	1N4148 (SMT)	D23	1N4148 (SMT)
D12	1N4148 (SMT)		
TRANSISTOR			
Q1	2N3904	Q14	2N3904
Q2	2SK3018	Q15	2N3904
Q3	2SK3018	Q16	2N3906
Q4	2SB1132	Q17	2N3906
Q5	2SB1132	Q19	2N3904
Q6	2N3906	Q20	2N3906
Q7	2N3906	Q21	2N3904
Q8	2N3906	Q22	2N3904
Q10	2N3906	Q23	2N3904
Q11	2N3904	Q24	2N3904
Q12	2N3906	Q25	2N3904
Q13	2N3906	Q26	2N3906
INDUCTOR			
L21	10uH	L33	1. 8uH
L22	10uH	L34	1. 8uH
L28	1. 8uH	L35	1. 8uH
L29	1. 8uH	L42	2. 7uH
L32	1. 8uH		
FERRITE BEAD			
L2	FERRITE BEAD	L6	FERB
L3	FERRITE BEAD	L7	FERRITE BEAD
L4	FERB	L8	FERRITE BEAD
L5	FERB	L9	FERRITE BEAD
L10	FERB	L19	FERRITE BEAD
L11	FERRITE BEAD	L20	FERRITE BEAD
L12	FERRITE BEAD	L23	FERRITE BEAD
L13	FERRITE BEAD	L24	FERRITE BEAD
L14	FERRITE BEAD	L25	FERRITE BEAD
L15	FERRITE BEAD	L26	FERRITE BEAD
L16	FERRITE BEAD	L30	FERRITE BEAD
L17	FERRITE BEAD	L37	FERRITE BEAD
L18	FERRITE BEAD	L38	FERRITE BEAD
SOCKET			
J8	AVG-2	J9	SAV-1
J5	AV6-8. 4-13P		

CONNECTOR			
J4	PH2-5	J3	PH2-4
J1	PH2-6	CON1	TJC3-8
J2	TJC3-5	J13	PH2-10
J11	AF324U (下接触)	J12	TJC3-4
CRYSTAL			
Y1	27.000MHz		
IC			
U1	AZ1117H-1.8 (1.8V)	U10	AT49F8192A
U2	G960T63U (3.3V)	U12	EEPROM 24C16
U4	MT1389BE	U14	WM8766
U5	BA5954	U13	4580
U6	BA6208F	U15	4580
U9	W986416BH-7	U16	4580
光纤	TOTX178A		

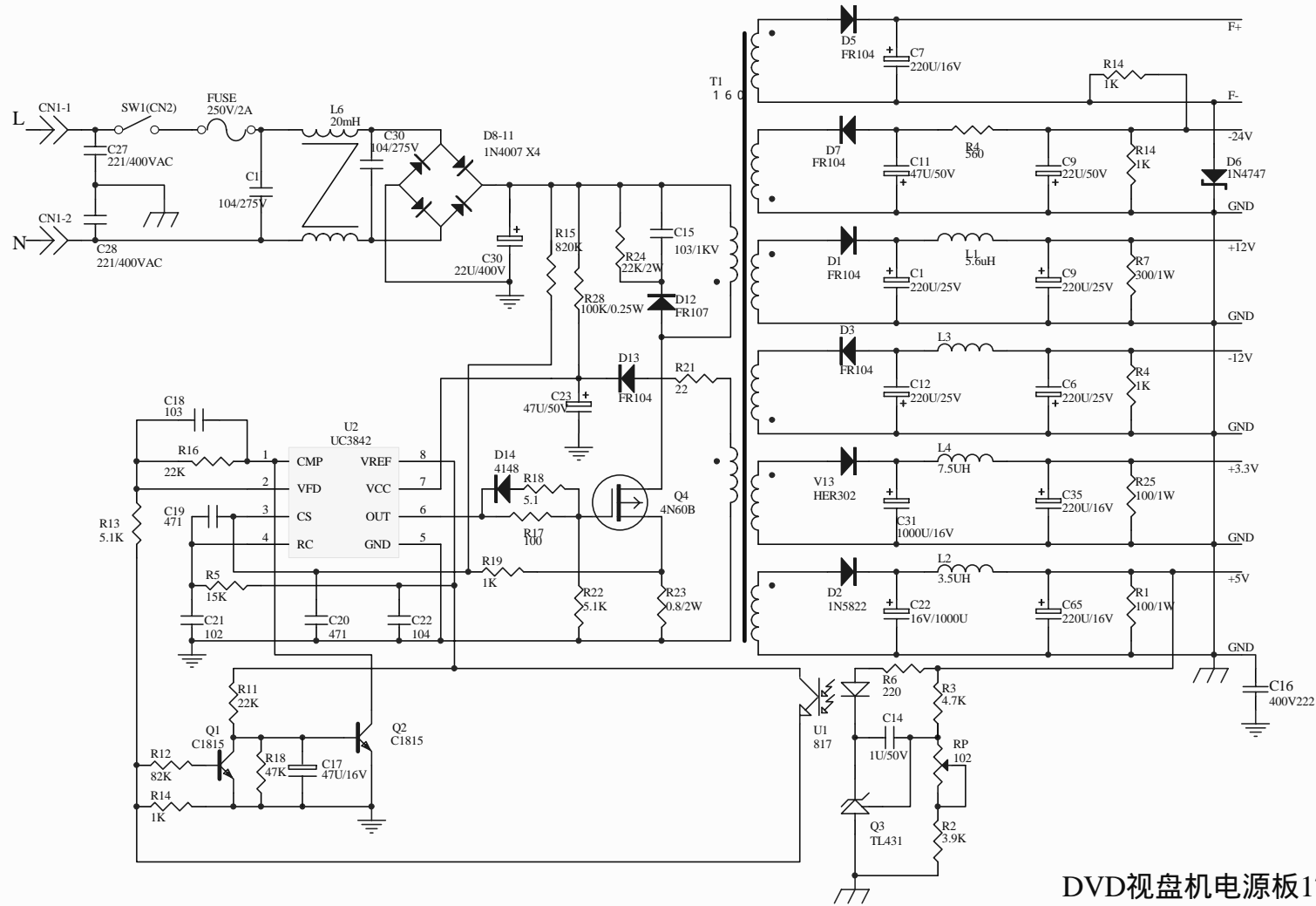

DVD视盘机电源板1792-F2

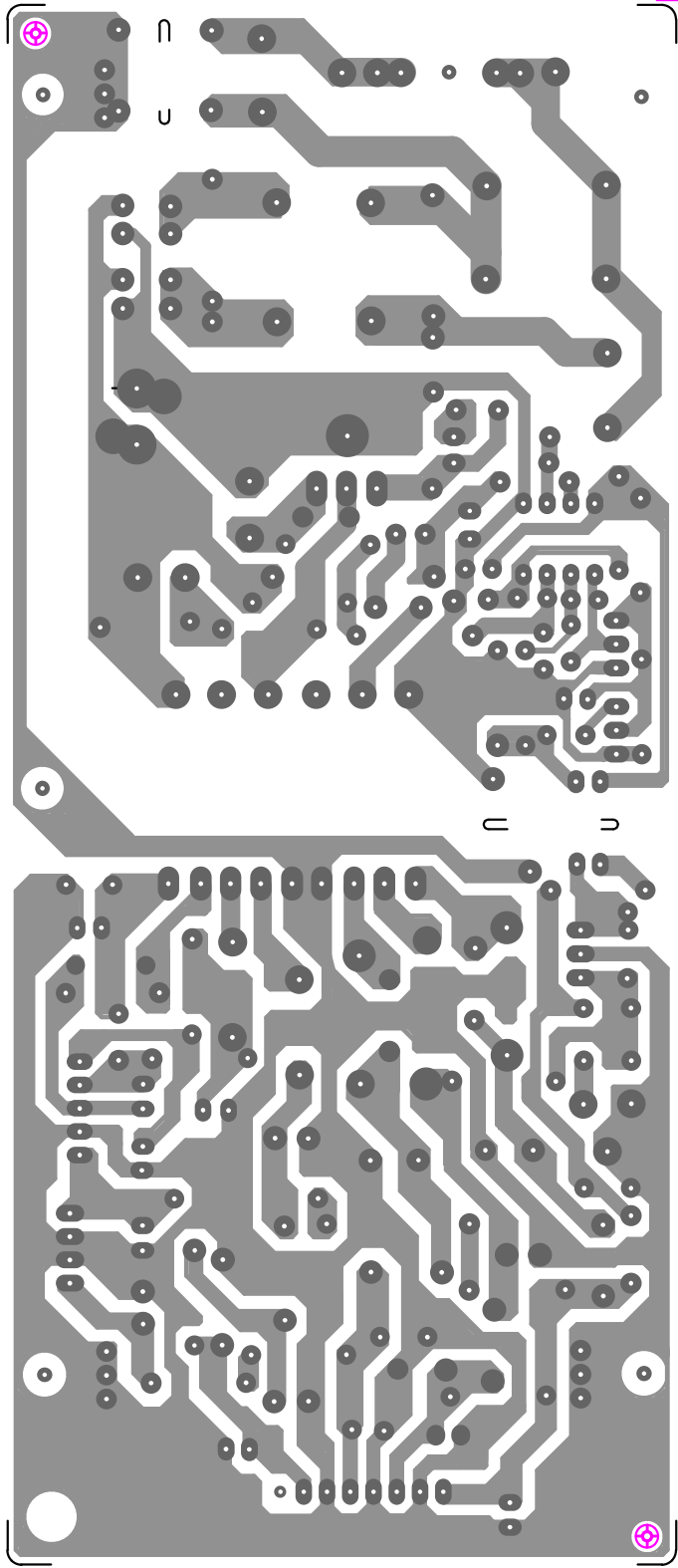

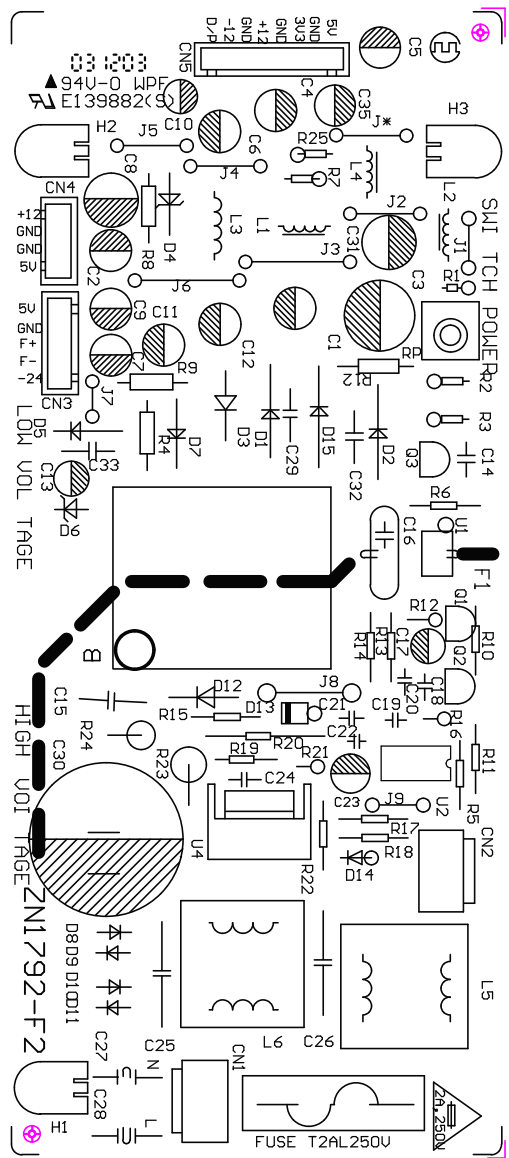

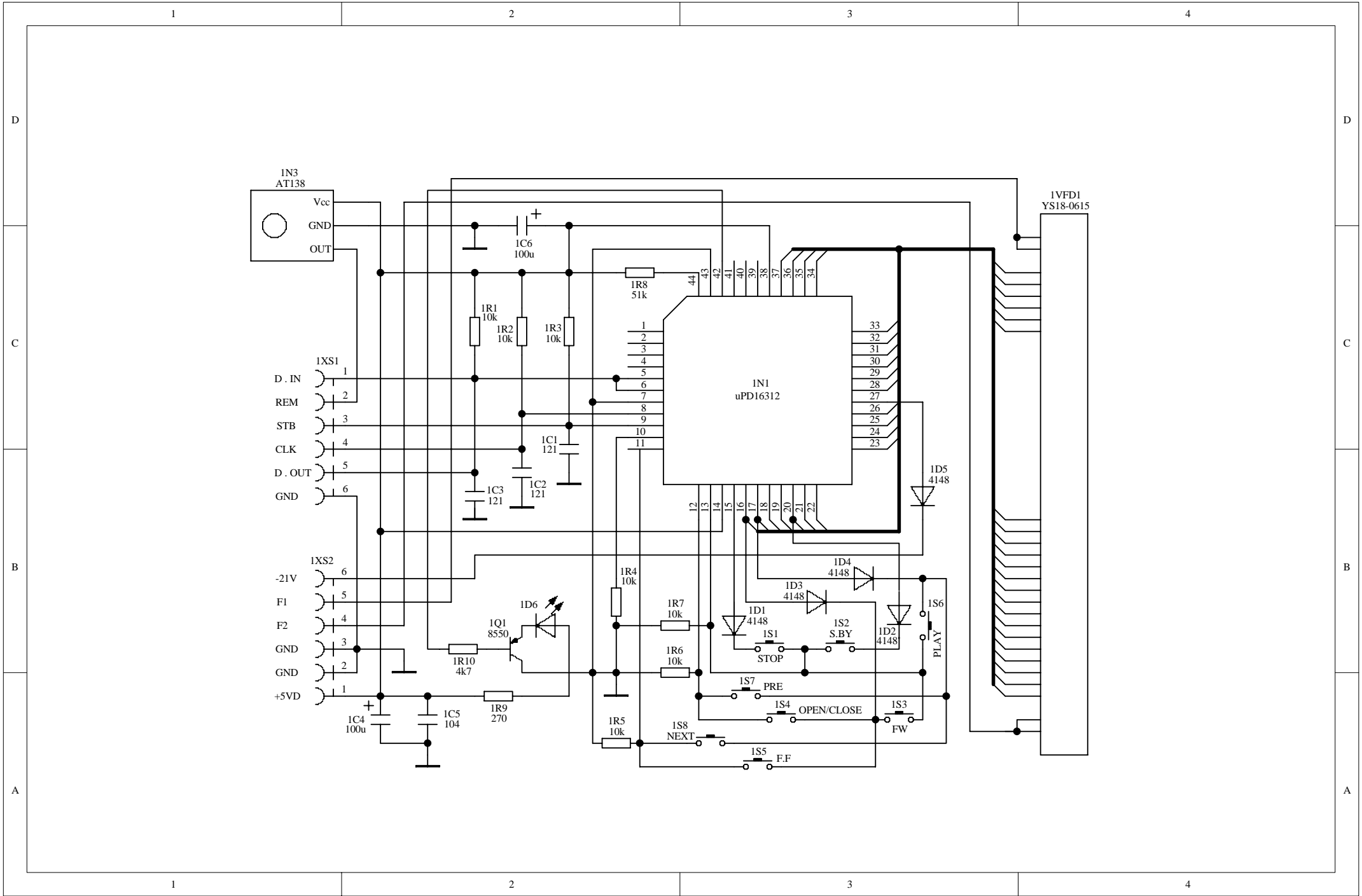

SIZE : 408 * 41

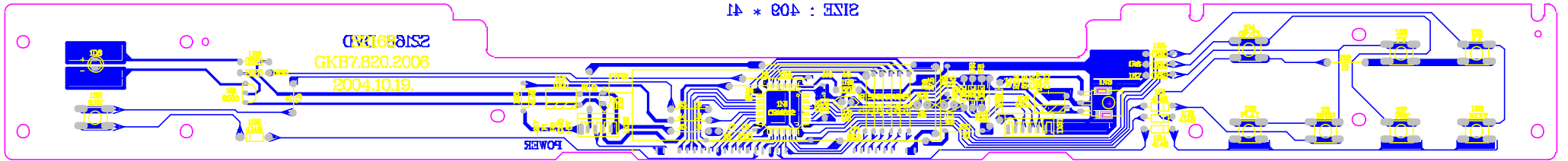

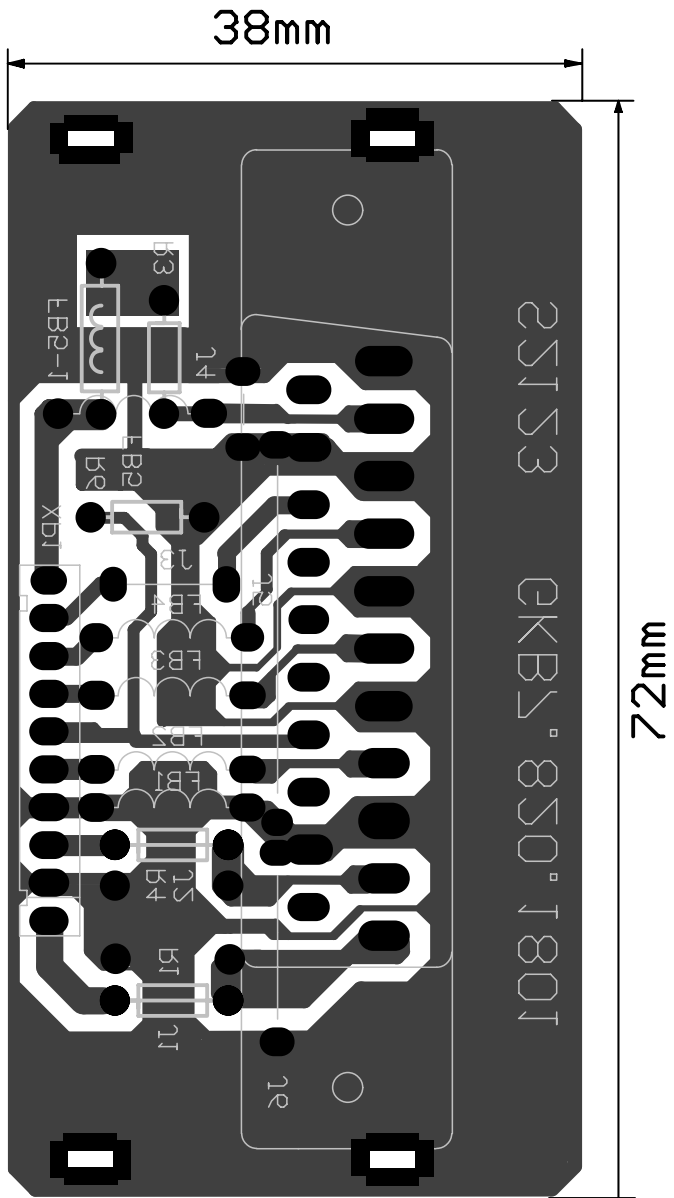

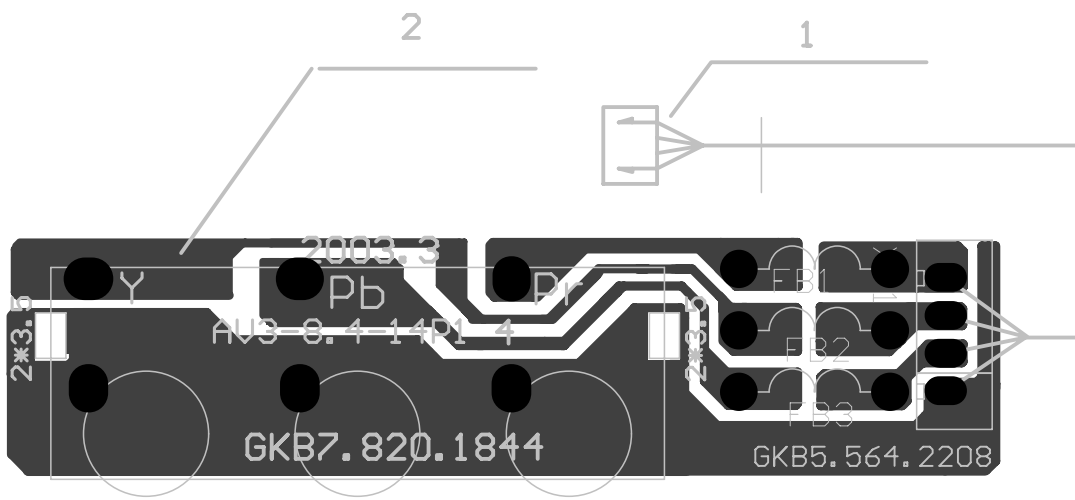

MTK-6CH-S2168

PARTS LIST OF OPERATION DISPLAY

REF NO	PART NO	DESCRIPTION
1R9	RT13-1/6W-	270±5%
1R10	RT13-1/6W-	4k7±5%
1R1	RT13-1/6W-	10k±5%
1R2	RT13-1/6W-	10k±5%
1R3	RT13-1/6W-	10k±5%
1R4	RT13-1/6W-	10k±5%
1R5	RT13-1/6W-	10k±5%
1R6	RT13-1/6W-	10k±5%
1R7	RT13-1/6W-	10k±5%
1R8	RT13-1/6W-	51k±10%
1D1	VHD1N4148	DIODE 1N4148
1D2	VHD1N4148	DIODE 1N4148
1D3	VHD1N4148	DIODE 1N4148
1D4	VHD1N4148	DIODE 1N4148
1D5	VHD1N4148	DIODE 1N4148
1Q1	2N8550	TRISISTER 2N8550
FD1	ASR-2040	3H-LED RED
1N1	1N1- μ PD16312	IC μ PD16312
1N2	REM	AT138-12
1C1	CS1-35V-121	120pF,±5%,35V,C
1C2	CS1-35V-121	120pF,±5%,35V,C
1C3	CS1-35V-121	120pF,±5%,35V,C
1C4	CD11-16V	100 μ F,±20%,16V E
1C5	CS1-35V-104	0.1 μ F,±5%,35V,C
1C6	CD11-16V	100 μ F,±20%,16V E
1FB1	FERB AXIAL	DIP FERB AXIAL
1S1~1S8	HCT-1101A-(6×6×5)	1S1~1S8
1VFD1	VFD	YS18-0615
J1	CONNECTOR WIRE	CCT-0.5-7.5mm
J2~J5	CONNECTOR WIRE	CCT-0.5-10mm
J6	CONNECTOR WIRE	CCT-0.5-27.5mm
J7	CONNECTOR WIRE	CCT-0.5-10mm
J8	CONNECTOR WIRE	CCT-0.5-25mm
J9	CONNECTOR WIRE	CCT-0.5-17.5mm
J10	CONNECTOR WIRE	CCT-0.5-40mm
J11~J16	CONNECTOR WIRE	CCT-0.5-15mm
J17	CONNECTOR WIRE	CCT-0.5-22.5mm
J18	CONNECTOR WIRE	CCT-0.5-17.5mm

J19	CONNECTOR WIRE	CCT-0.5-7.5mm
J20	CONNECTOR WIRE	CCT-0.5-10mm
J21	CONNECTOR WIRE	CCT-0.5-12.5mm
J22	CONNECTOR WIRE	CCT-0.5-10mm

PARTS LIST OF SCART

SCART		21pin SCART socket
R6	RT13-1/6W-	6k2±5%
FB1~FB4	FERB AXIAL	DIP FERB AXIAL
FB5	CONNECTOR WIRE	CCT-0.5-7.5mm
J1~J3	CONNECTOR WIRE	CCT-0.5-7.5mm
J4	CONNECTOR WIRE	CCT-0.5-5mm
J5	CONNECTOR WIRE	CCT-0.5-25mm
J6	CONNECTOR WIRE	CCT-0.5-12.5mm

PARTS LIST OF Y/Cb/Cr

JACK	AV3-8.4-14P1
FB1~FB3	FERB AXIAL

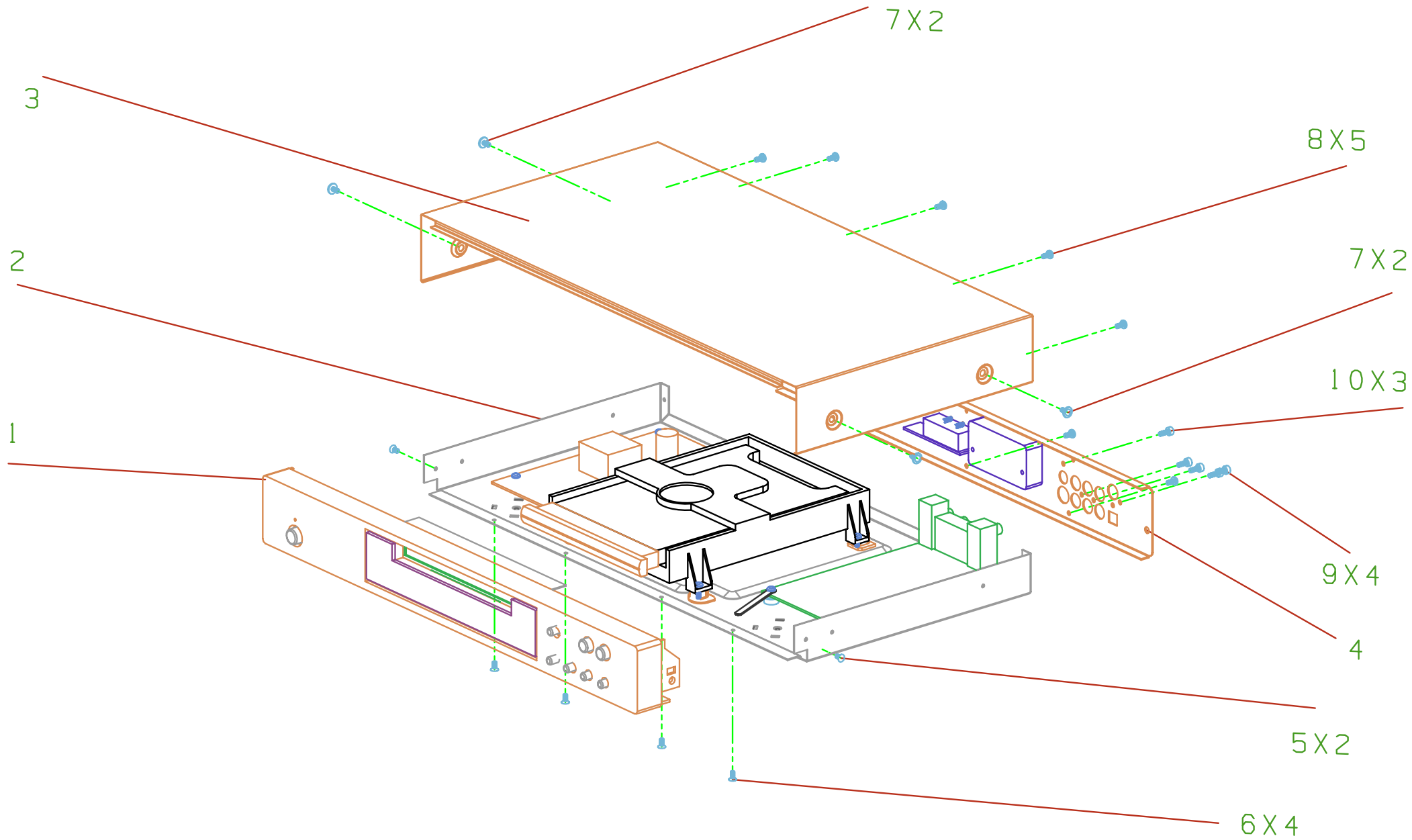

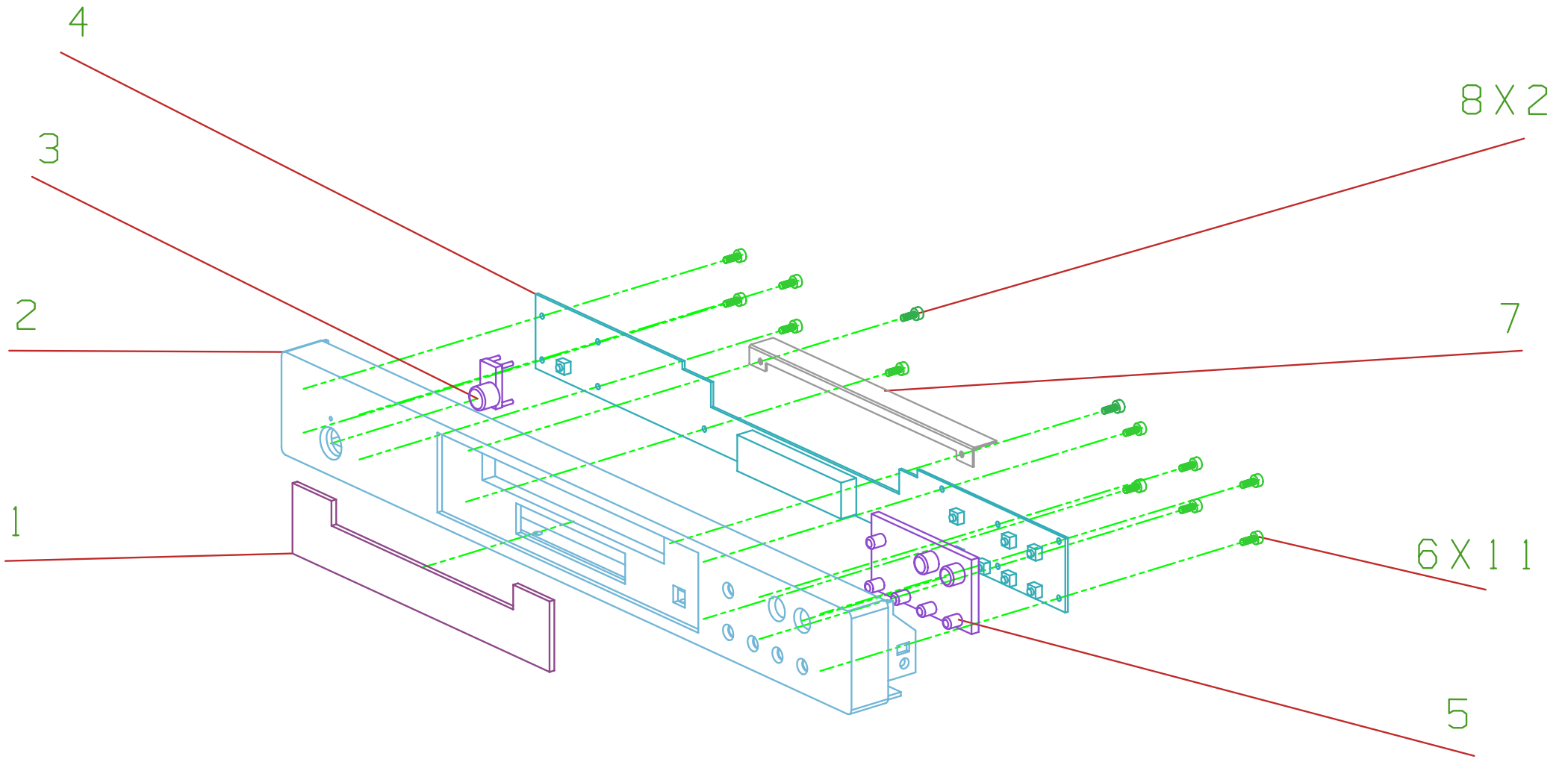

subassembly_1

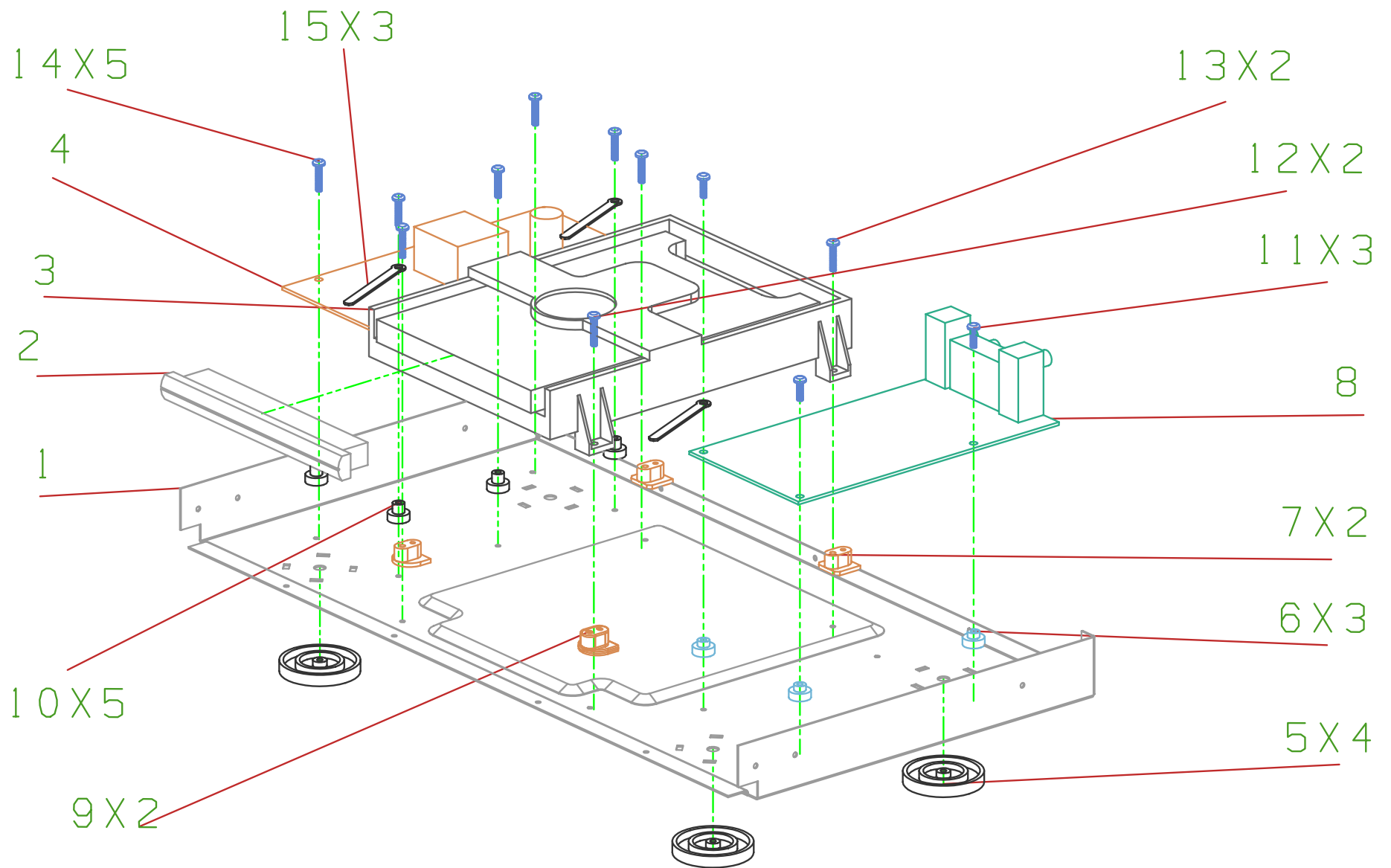

subassembly_2

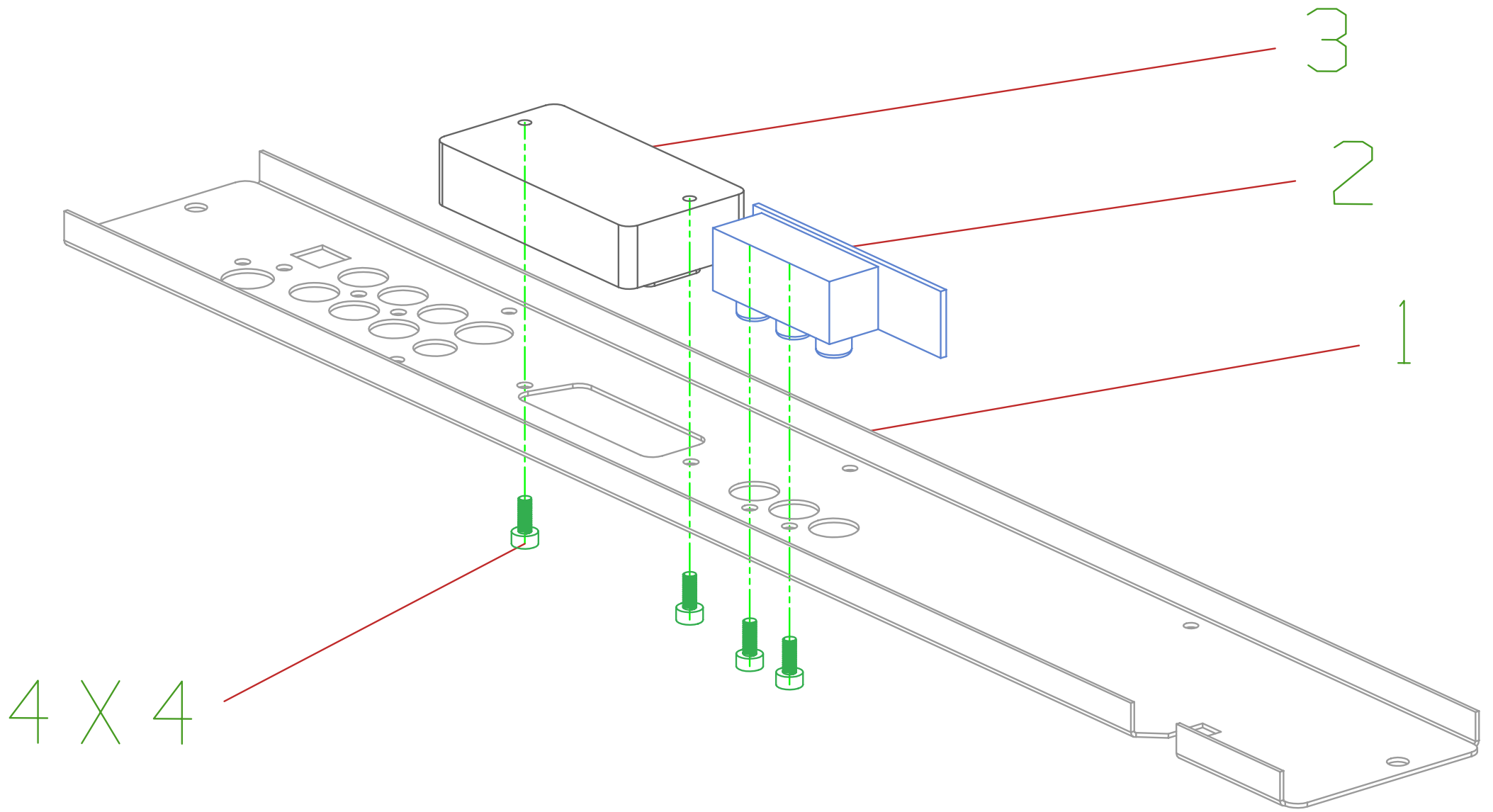

subassembly_3

S2168 Cabinet Exploded View Parts List

NO.	CODE NAME	NAME	Quantity
1		Subassembly_1	1
2		Subassembly_2	1
3	GKB8.040.339	Top cabinet	1
4		Subassembly_3	1
5	GB6561-86	M3X6	2
6	GB6561-86	M3X6	4
7		M3X6(with gasket)	4
8	GB6560-86	M3X6	5
9	SJ2821-87	ST3 × 8BT	5
10	GB6560-86	M3X6	3

Subassembly_1 Exploded View Parts List

NO.	CODE NAME	NAME	Quantity
1	GKB8.640.761	Clarity window	1
2	GKB8.081.565	Front cabinet	1
3	GKB8.335.744	Single key	1
4		Control board	1
5	GKB8.335.743	Unit key	1
6	SJ2821-87	ST3 × 8 BT	11
7	GKB8.038.388	Bracket	1
8	SJ2821-87	ST3 × 8 BT	2

Subassembly_2 Exploded View Parts List

NO.	CODE NAME	NAME	Quantity
1	GKB8.031.278	Bottom cabinet	1
2	GKB8.082.213	Door	1
3		Loader	1
4		Power board	1
5	GKB8.085.167	Feet	4
6	GKB8.078.457	Pad (9.5vmm)	3
7	GKB8.085.166	Loader pad(back)	2
8		Avboard	1
9	GKB8.085.165	Loader pad(front)	2
10	GKB8.078.418	Pad (11vmm)	5
11	GB6560-86	M3 × 14	3
12	GB6560-86	M3 × 17	2
13	GB6560-86	M3 × 14	2
14	GB6560-86	M3 × 17	5

15	GKB8.078.420	Fixture clip	3
----	--------------	--------------	---

Subassembly_3 Exploded View Parts List

NO.	CODE NAME	NAME	Quantity
1	GKB8.040.337	Back cabinet	1
2		Y-Cb-Cr	1
3		Scart	1
4	SJ2821-87	ST3 × 8BT	4