

Service Manual

DV4600 /N1B/N1S

DVD Player

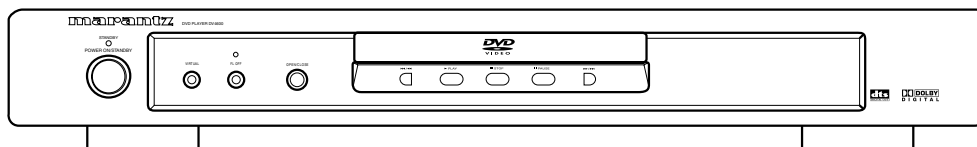

TABLE OF CONTENTS

SECTION	PAGE
TECHNICAL SPECIFICATIONS.....	1-1-1
SERVICE HINTS AND TOOLS.....	1-2-1
WARNING AND LASER SAFETY INSTRUCTIONS	1-2-2
LASER BEAM SAFETY PRECAUTIONS.....	1-2-3
IMPORTANT SAFETY PRECAUTIONS	1-3-1
STANDARD NOTES FOR SERVICING	1-4-1
CABINET DISASSEMBLY INSTRUCTIONS	1-5-1
HOW TO INITIALIZE THE DVD PLAYER	1-6-1
FIRMWARE RENEWAL MODE.....	1-7-1
TROUBLESHOOTING.....	1-8-1
BLOCK DIAGRAMS	1-9-1
SCHEMATIC DIAGRAMS / CBA'S AND TEST POINTS	1-10-1
WAVEFORMS	1-11-1
WIRING DIAGRAM	1-12-1
IC PIN FUNCTION DESCRIPTIONS	1-13-1
LEAD IDENTIFICATIONS.....	1-14-1
EXPLODED VIEWS	1-15-1
PARTS LIST	1-16-1

Please use this service manual with referring to the user guide (D.F.U.) without fail.
修理の際は、必ず取扱説明書を準備し操作方法を確認の上作業を行ってください。

marantz®

DV4600

Part no. 90M39BW855010
First Issue 2005.06
MZ

DV4600

MARANTZ DESIGN AND SERVICE

Using superior design and selected high grade components, **MARANTZ** company has created the ultimate in stereo sound. Only original **MARANTZ** parts can insure that your **MARANTZ** product will continue to perform to the specifications for which it is famous.

Parts for your **MARANTZ** equipment are generally available to our National Marantz Subsidiary or Agent.

ORDERING PARTS :

Parts can be ordered either by mail or by Fax.. In both cases, the correct part number has to be specified.

The following information must be supplied to eliminate delays in processing your order :

1. Complete address
2. Complete part numbers and quantities required
3. Description of parts
4. Model number for which part is required
5. Way of shipment
6. Signature : any order form or Fax. must be signed, otherwise such part order will be considered as null and void.

USA

MARANTZ AMERICA, INC
1100 MAPLEWOOD DRIVE
ITASCA, IL. 60143
USA
PHONE : 630 - 741 - 0300
FAX : 630 - 741 - 0301

EUROPE / TRADING

MARANTZ EUROPE B.V.
P. O. BOX 8744, BUILDING SILVERPOINT
BEEMDSTRAAT 11, 5653 MA EINDHOVEN
THE NETHERLANDS
PHONE : +31 - 40 - 2507844
FAX : +31 - 40 - 2507860

CANADA

MARANTZ CANADA INC.
5-505 APPLE CREEK BLVD.
MARKHAM, ONTARIO L3R 5B1
CANADA
PHONE : 905 - 415 - 9292
FAX : 905 - 475 - 4159

AUSTRALIA

QualiFi Pty Ltd,
24 LIONEL ROAD,
MT. WAVERLEY VIC 3149
AUSTRALIA
PHONE : +61 - (0)3 - 9543 - 1522
FAX : +61 - (0)3 - 9543 - 3677

THAILAND

MRZ STANDARD CO., LTD
746 - 754 MAHACHAI ROAD.,
WANGBURAPAPIROM, PHRANAKORN,
BANGKOK, 10200 THAILAND
PHONE : +66 - 2 - 222 9181
FAX : +66 - 2 - 224 6795

SINGAPORE

WO KEE HONG DISTRIBUTION PTE LTD
No.1 JALAN KILANG TIMOR
#08-03 PACIFIC TECH CENTRE
SINGAPORE 159303
PHONE : +65 6376 0338
FAX : +65 6376 0166

NEW ZEALAND

WILDASH AUDIO SYSTEMS NZ
14 MALVERN ROAD MT ALBERT
AUCKLAND NEW ZEALAND
PHONE : +64 - 9 - 8451958
FAX : +64 - 9 - 8463554

TAIWAN

PAI-YUING CO., LTD.
6 TH FL NO, 148 SUNG KIANG ROAD,
TAIPEI, 10429, TAIWAN R.O.C.
PHONE : +886 - 2 - 25221304
FAX : +886 - 2 - 25630415

MALAYSIA

WO KEE HONG ELECTRONICS SDN. BHD.
2ND FLOOR BANGUNAN INFINITE CENTRE
LOT 1, JALAN 13/6, 46200 PETALING JAYA
SELANGOR DARUL EHSAN, MALAYSIA
PHONE : +60 - 3 - 7954 8088
FAX : +60 - 3 - 7954 7088

JAPAN *Technical*

D&M Holdings Inc.
35- 1, 7- CHOME, SAGAMIONO
SAGAMIHARA - SHI, KANAGAWA
JAPAN 228-8505
PHONE : +81 42 748 1013
FAX : +81 42 741 9190

株式会社 ティーアンドエムホールディングス

本 社 〒228-8505
神奈川県相模原市相模大野7-35-1

KOREA

MARANTZ KOREA CO., LTD.
ROOM 604, ELECTRO OFFICE, 16-58,
HANGGANG-RO 3GA, YONGSAN-KU,
SEOUL, 140-013, KOREA
PHONE : +82 - 2 - 323 - 2155
FAX : +82 - 2 - 323 - 2154

SHOCK, FIRE HAZARD SERVICE TEST :

CAUTION : After servicing this appliance and prior to returning to customer, measure the resistance between either primary AC cord connector pins (with unit NOT connected to AC mains and its Power switch ON), and the face or Front Panel of product and controls and chassis bottom.

Any resistance measurement less than 1 Megohms should cause unit to be repaired or corrected before AC power is applied, and verified before it is return to the user/customer.

Ref. UL Standard No. 1492.

In case of difficulties, do not hesitate to contact the Technical Department at above mentioned address.

TECHNICAL SPECIFICATIONS

SPECIFICATIONS

SIGNAL SYSTEM

PAL colour

APPLICABLE DISCS

- (1) DVD-Video Discs
 - 1-layer 12cm single-sided discs, 2-layer 12cm single-sided discs, 2-layer 12cm double-sided discs (1 layer per side)
 - 1-layer 8cm single-sided discs, 2-layer 8cm single-sided discs, 2-layer 8cm double-sided discs (1 layer per side)
- (2) DVD-R/DVD-RW
- (3) Compact discs (CD-DA, Video CD)
 - 12cm discs, 8cm discs
- (4) CD-R/CD-RW

S-VIDEO OUTPUT

Y output level: 1Vp-p (75Ω/ohms)
C output level: 0.3Vp-p
Output connectors: S connectors, 1 set

VIDEO OUTPUT

Output level: 1Vp-p (75Ω/ohms)
Output connector: Pin jacks, 1 set

COMPONENT OUTPUT

Y output level: 1Vp-p (75Ω/ohms)
C_B/P_B output level: 0.7Vp-p (75Ω/ohms)
C_R/P_R output level: 0.7Vp-p (75Ω/ohms)
Output connector: Pin jacks, 1 set

AUDIO/VIDEO

21-pin scart jack

AUDIO OUTPUT

Output level: 2Vrms
2 channel (L, R) output connector: Pin jack, 1 set

AUDIO OUTPUT PROPERTIES

- (1) Frequency response
 - 1 DVDs (linear PCM) : 4Hz to 22kHz (48 kHz sampling)
 - : 4Hz to 44kHz (96 kHz sampling)
 - 2 CDs : 4Hz to 20kHz
- (2) S/N ratio : 115dB
- (3) Total harmonic distortion : 1kHz CD: 0.0045%
- (4) Dynamic range : DVD: 100dB
 CD: 98dB

DIGITAL AUDIO OUTPUT

Optical digital output: Optical connector, 1 set
Coaxial digital output: Pin jack, 1 set

POWER SUPPLY

AC 200-240V, 50Hz

POWER CONSUMPTION

12 W

MAXIMUM EXTERNAL DIMENSIONS

440 (width) x 65 (height) x 313 (depth) mm

MASS

2.4 Kg (5.3 lbs)

REMOTE CONTROL UNIT

RC6600DV
Infrared pulse type
Supply: DC 3V, 2 R6P/AA batteries

PIN CONNECTION (A/V EURO CONNECTOR)

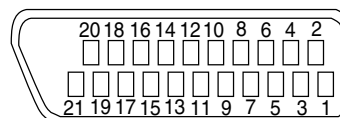

Contacts, signal levels and impedances

<i>Contact 1</i>	Audio Output (Right):	2.0Vrms/ 1kΩ
<i>Contact 3</i>	Audio Output (Left):	2.0Vrms/ 1kΩ
<i>Contact 4</i>	Audio, Ground	
<i>Contact 5</i>	RGB, Ground (Blue)	
<i>Contact 7</i>	RGB Output (Blue):	0.7Vp-p/75Ω
<i>Contact 8</i>	Function Select Switching Control	
	L:	0.0~2.0V DC Power Off
	M:	4.5~7.0V DC Wide-Screen Mode (16:9)
	H:	9.5~12.0V DC Normal Mode (4:3)
<i>Contact 9</i>	RGB, Ground (Green)	
<i>Contact 11</i>	RGB Output (Green):	0.7Vp-p/75Ω
<i>Contact 13</i>	RGB, Ground (Red)	
<i>Contact 14</i>	RGB Switching Control, Ground	
<i>Contact 15</i>	RGB Output (Red):	0.7Vp-p/75Ω
<i>Contact 16</i>	RGB Switching Control	
	H:	3.3V DC RGB Mode
<i>Contact 17</i>	Video Output Signal, Ground	
<i>Contact 18</i>	Video Input Signal, Ground	
<i>Contact 19</i>	Video Output (CVBS):	1.0Vp-p/75Ω
<i>Contact 21</i>	Common Ground (shielding)	

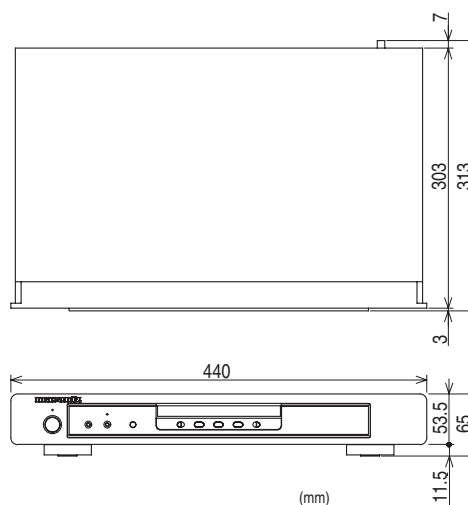

ABOUT THE DISCS

Playable Discs

Playable discs	Mark (logo)	Region code	Recorded signals	Disc size	Disc types
DVD-Video * 1, 2, 3, 5		or	Digital video (MPEG2)	12 cm or 8 cm	
DVD-RW DVD-R * 1, 3, 4, 5, 6, 7, 8	 	-			
Video CD * 1, 3, 5, 9		-	Sound and Picture	12 cm or 8 cm	
Audio CD * 4, 5		-	Digital audio		
CD-RW CD-R * 4, 5, 7	 	-	Digital audio MP3 WMA*10 Digital picture (JPEG)		
Picture CD		-	JPEG	12 cm	



is a trademark of DVD Format/Logo Licensing Corporation.



is trademark of Eastman Kodak Company.



This label indicates playback compatibility with DVD-RW discs recorded in VR mode (Video Recording format).



Windows Media and the Windows logo are trademarks or registered trademarks of Microsoft Corporation in the United States and/or other countries.

This unit is not compatible with Multiple Bit Rate (MBR: a file that contains the same content encoded at several different bit rates).

If you cannot play back a disc which bears one of the marks above, check the following notes.

- *1: This player conforms to the PAL colour system. Also you can play discs recorded with the NTSC system via a PAL system TV set.
- *2: Certain DVD-Video discs do not operate as described in this manual due to the intentions of the disc's producers.
- *3: Scratched or stained discs may not be played back.
- *4: Some discs cannot be played back because of incompatible recording conditions, characteristics of the recorder or special properties of discs.
- *5: You can play back discs which bear the marks above. If you use nonstandardized discs, this unit may not play them back. Even if they are played back, the sound or video quality will be compromised.
- *6: Only the discs recorded in the video format or Video Recording format, and finalized can be played back. Unfinalized discs cannot be played back. Depending on the recording status of a disc, the disc may not be played back at all or normally (the picture or sound may be distorted, etc.).
- *7: If there is too much recordable space left on a disc (the used portion is less than 55mm across), it may not play back properly.
- *8: Do not glue paper or put stickers on to the disc. These may damage the disc, and the unit may not read it correctly.
- *9: This unit conforms to ver.1.1 and ver.2.0 of Video CD standard with PBC function.
Ver.1.1 (without PBC function): You can enjoy playback picture as well as music CD.
Ver.2.0 (with PBC function): While using a Video CD with PBC function, "Pbc" appears on the screen and the display.
NOTE: When playing Video CDs with PBC function, some operations (e.g., track search and repeat tracks) cannot be performed. Cancel PBC function temporarily to perform those operations (refer to page 15).

What is PBC? "PBC" stands for Playback Control.

You can play interactive software using menu screens. Refer to instructions in the Video CD.

*10: This player cannot play the disc contents protected by Windows Media Digital Rights Management (DRM).

NOTE: This player cannot play the DVD-RW discs that supports CPRM (Content Protection for Recordable Media).

This player cannot play the DVD-R discs recorded in VR mode (Video Recording format).

- **NEVER play back the following discs. Otherwise, malfunction may result!**
 DVD-RAM / CD-I / Photo CD / DVD with region codes other than 2 or ALL / DVD-ROM for personal computers / CD-ROM for personal computers
- **On the following disc, the sound MAY NOT be heard.**
 Super Audio CD
NOTES:
 - Only the sound recorded on the normal CD layer can be delivered.
 - The sound recorded on the high density Super Audio CD layer cannot be delivered.
- Any other discs without compatibility indications

CAUTION:

- Use caution not to pinch your finger in the disc slot.
- Be sure to remove a disc and unplug the AC power cord from the outlet before carrying the DVD player.

SERVICE HINTS AND TOOLS

SERVICE HINTS

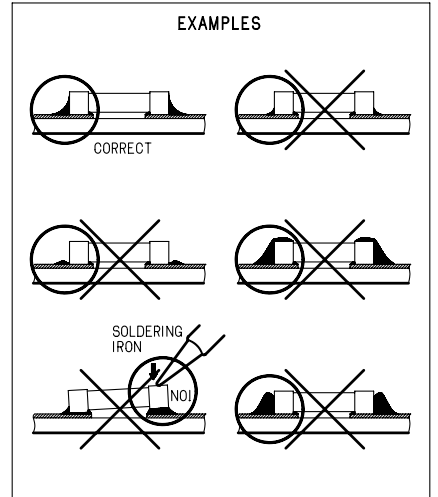
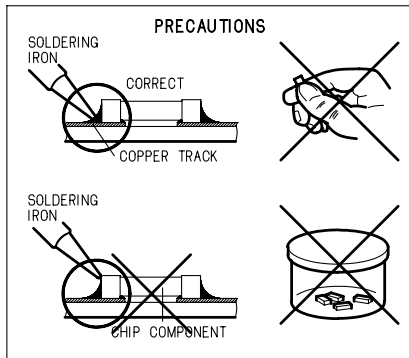
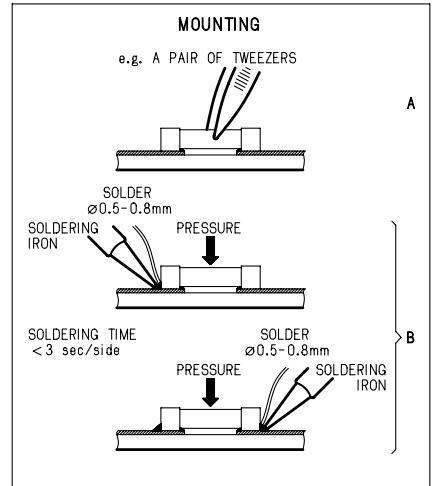
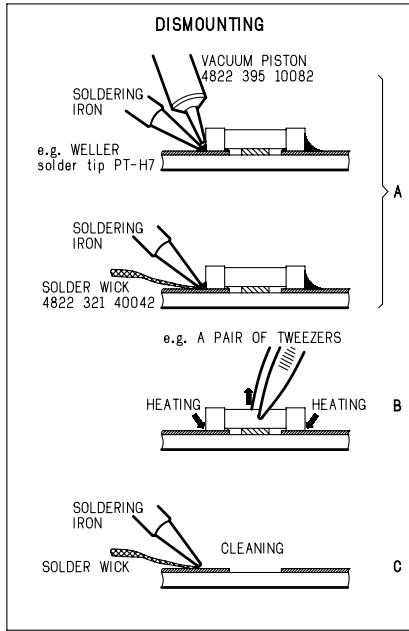
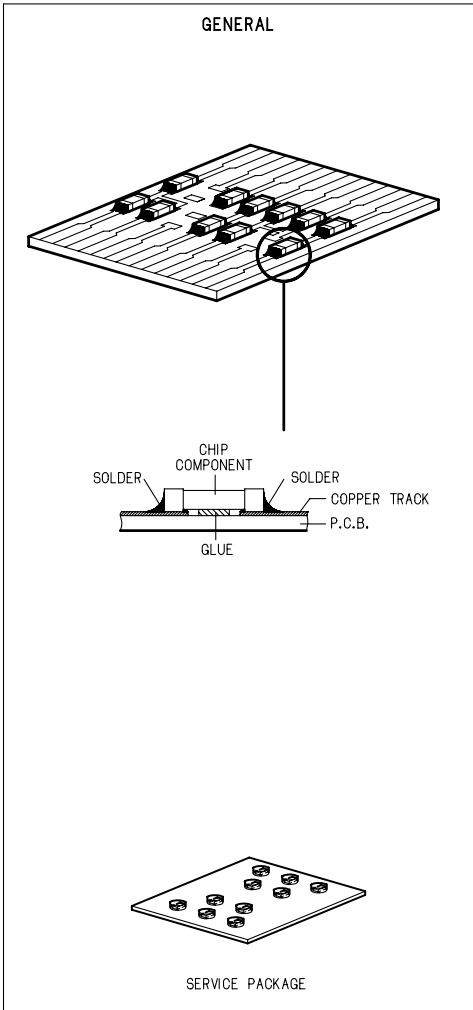

SERVICE TOOLS

Audio signals disc	4822 397 30184
Disc without errors (SBC444)+	
Disc with DO errors, black spots and fingerprints (SBC444A)	4822 397 30245
Disc (65 min 1kHz) without no pause	4822 397 30155
Max. diameter disc (58.0 mm)	4822 397 60141
Torx screwdrivers	
Set (straight)	4822 395 50145
Set (square)	4822 395 50132
13th order filter	4822 395 30204
DVD test disc (PAL)	4822 397 10131
DVD test disc (NTSC) ALMEDIO	TDV-540

WARNING AND LASER SAFETY INSTRUCTIONS

GB WARNING

All ICs and many other semi-conductors are susceptible to electrostatic discharges (ESD). Careless handling during repair can reduce life drastically.
When repairing, make sure that you are connected with the same potential as the mass of the set via a wrist wrap with resistance.
Keep components and tools also at this potential.



NL WAARSCHUWING

Alle IC's en vele andere halfgeleiders zijn gevoelig voor elektrostatische ontladingen (ESD).
Onzorgvuldig behandelen tijdens reparatie kan de levensduur drastisch doen verminderen.
Zorg ervoor dat u tijdens reparatie via een polsband met weerstand verbonden bent met hetzelfde potentiaal als de massa van het apparaat.
Houd componenten en hulpmiddelen ook op hetzelfde potentiaal.

F ATTENTION

Tous les IC et beaucoup d'autres semi-conducteurs sont sensibles aux décharges statiques (ESD).
Leur longévité pourrait être considérablement écourtée par le fait qu'aucune précaution n'est prise à leur manipulation.
Lors de réparations, s'assurer de bien être relié au même potentiel que la masse de l'appareil et enfiler le bracelet serti d'une résistance de sécurité.
Veiller à ce que les composants ainsi que les outils que l'on utilise soient également à ce potentiel.

D WARNUNG

Alle IC und viele andere Halbleiter sind empfindlich gegen elektrostatische Entladungen (ESD).
Unvorsichtige Behandlung bei der Reparatur kann die Lebensdauer drastisch vermindern.
Sorgen sie dafür, das Sie im Reparaturfall über ein Pulsarmband mit Widerstand mit dem Massepotential des Gerätes verbunden sind.
Halten Sie Bauteile und Hilfsmittel ebenfalls auf diesem Potential.

I AVVERTIMENTO

Tutti IC e parecchi semi-conduttori sono sensibili alle scariche statiche (ESD).
La loro longevita potrebbe essere fortemente ridatta in caso di non osservazione della piu grande cauzione alla loro manipolazione.
Durante le riparazioni occorre quindi essere collegato allo stesso potenziale che quello della massa dell'apparecchio tramite un braccialetto a resistenza.
Assicurarsi che i componenti e anche gli utensili con quali si lavora siano anche a questo potenziale.

GB

Safety regulations require that the set be restored to its original condition and that parts which are identical with those specified be used.

NL

Veiligheidsbepalingen vereisen, dat het apparaat in zijn oorspronkelijke toestand wordt terug gebracht en dat onderdelen, identiek aan de gespecificeerde worden toegepast.

D

Bei jeder Reparatur sind die geltenden Sicherheitsvorschriften zu beachten.
Der Originalzustand des Gerats darf nicht verändert werden.
Für Reparaturen sind Original-Ersatzteile zu verwenden.

I

Le norme di sicurezza esigono che l'apparecchio venga rimesso nelle condizioni originali e che siano utilizzati pezzi di ricambio identici a quelli specificati.

F

Les normes de sécurité exigent que l'appareil soit remis à l'état d'origine et que soient utilisées les pièces de rechange identiques à celles spécifiées.

"Pour votre sécurité, ces documents doivent être utilisés par des spécialistes agréés, seuls habilités à réparer votre appareil en panne."

LASER SAFETY

This unit employs a laser. Only a qualified service person should remove the cover or attempt to service this device, due to possible eye injury.



USE OF CONTROLS OR ADJUSTMENTS OR PERFORMANCE OF PROCEDURE OTHER THAN THOSE SPECIFIED HEREIN MAY RESULT IN HAZARDOUS RADIATION EXPOSURE.

AVOID DIRECT EXPOSURE TO BEAM

WARNING

**The use of optical instruments with this product will increase eye hazard.
Repair handling should take place as much as possible with a disc loaded inside the player**

WARNING LOCATION: INSIDE ON LASER COVERSIELD

CAUTION VISIBLE AND INVISIBLE LASER RADIATION WHEN OPEN AVOID EXPOSURE TO BEAM
ADVARSEL SYNLIG OG USYNLIG LASERSTRÅLING VED ÅBNING UNDGÅ UDSÆTTELSE FOR STRÅLING
ADVARSEL SYNLIG OG USYNLIG LASERSTRÅLING NÅR DEKSEL Å PNES UNNGÅ EKSPONERING FOR STRÅLEN
VARNING SYNLIG OCH OSYNLIG LASERSTRÅLNING NÅR DENNA DEL ÅR ÖPPNAD BETRAKTA EJ STRÅLEN
VARO! AVATT AESSA OLET ALTTIINA NÄKYVÄLLE JA NÄKYMÄTTÖMÄLLE LASER SÄTEILYLLE. ÄLÄ KATSO SÄTEESEEN
VORSICHT SICHTBARE UND UNSICHTBARE LASERSTRAHLUNG WENN ABDECKUNG GEÖFFNET NICHT DEM STRAHL AUSSETZEN
DANGER VISIBLE AND INVISIBLE LASER RADIATION WHEN OPEN AVOID DIRECT EXPOSURE TO BEAM
ATTENTION RAYONNEMENT LASER VISIBLE ET INVISIBLE EN CAS D'OUVERTURE EXPOSITION DANGEREUSE AU FAISCEAU

LASER BEAM SAFETY PRECAUTIONS

This DVD player uses a pickup that emits a laser beam.

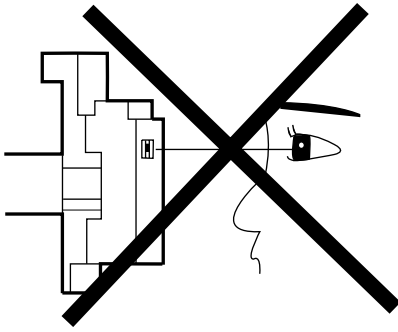

Do not look directly at the laser beam coming from the pickup or allow it to strike against your skin.

The laser beam is emitted from the location shown in the figure. When checking the laser diode, be sure to keep your eyes at least 30 cm away from the pickup lens when the diode is turned on. Do not look directly at the laser beam.

CAUTION: Use of controls and adjustments, or doing procedures other than those specified herein, may result in hazardous radiation exposure.

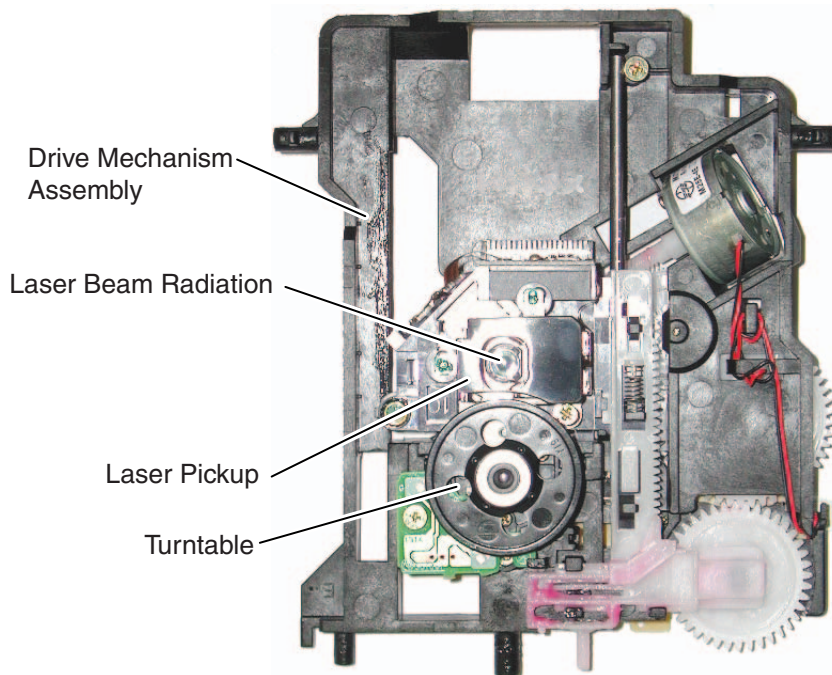

CAUTION - CLASS 1M LASER RADIATION WHEN OPEN. DO NOT VIEW DIRECTLY WITH OPTICAL INSTRUMENTS

Location: Top of DVD mechanism.

IMPORTANT SAFETY PRECAUTIONS

Product Safety Notice

Some electrical and mechanical parts have special safety-related characteristics which are often not evident from visual inspection, nor can the protection they give necessarily be obtained by replacing them with components rated for higher voltage, wattage, etc. Parts that have special safety characteristics are identified by a \triangle on schematics and in parts lists. Use of a substitute replacement that does not have the same safety characteristics as the recommended replacement part might create shock, fire, and/or other hazards. The Product's Safety is under review continuously and new instructions are issued whenever appropriate. Prior to shipment from the factory, our products are carefully inspected to confirm with the recognized product safety and electrical codes of the countries in which they are to be sold. However, in order to maintain such compliance, it is equally important to implement the following precautions when a set is being serviced.

Precautions during Servicing

- A.** Parts identified by the \triangle symbol are critical for safety. Replace only with part number specified.
- B.** In addition to safety, other parts and assemblies are specified for conformance with regulations applying to spurious radiation. These must also be replaced only with specified replacements.
Examples: RF converters, RF cables, noise blocking capacitors, and noise blocking filters, etc.
- C.** Use specified internal wiring. Note especially:
 - 1) Wires covered with PVC tubing
 - 2) Double insulated wires
 - 3) High voltage leads
- D.** Use specified insulating materials for hazardous live parts. Note especially:
 - 1) Insulation tape
 - 2) PVC tubing
 - 3) Spacers
 - 4) Insulators for transistors
- E.** When replacing AC primary side components (transformers, power cord, etc.), wrap ends of wires securely about the terminals before soldering.
- F.** Observe that the wires do not contact heat producing parts (heatsinks, oxide metal film resistors, fusible resistors, etc.).
- G.** Check that replaced wires do not contact sharp edges or pointed parts.
- H.** When a power cord has been replaced, check that 5 - 6 kg of force in any direction will not loosen it.
- I.** Also check areas surrounding repaired locations.
- J.** Use care that foreign objects (screws, solder droplets, etc.) do not remain inside the set.
- K.** Crimp type wire connector
The power transformer uses crimp type connectors which connect the power cord and the primary side of the transformer. When replacing the transformer, follow these steps carefully and precisely to prevent shock hazards.
Replacement procedure
 - 1) Remove the old connector by cutting the wires at a point close to the connector.
Important: Do not re-use a connector. (Discard it.)
 - 2) Strip about 15 mm of the insulation from the ends of the wires. If the wires are stranded, twist the strands to avoid frayed conductors.
 - 3) Align the lengths of the wires to be connected. Insert the wires fully into the connector.
 - 4) Use a crimping tool to crimp the metal sleeve at its center. Be sure to crimp fully to the complete closure of the tool.
- L.** When connecting or disconnecting the internal connectors, first, disconnect the AC plug from the AC outlet.

Safety Check after Servicing

Examine the area surrounding the repaired location for damage or deterioration. Observe that screws, parts, and wires have been returned to their original positions. Afterwards, do the following tests and confirm the specified values to verify compliance with safety standards.

1. Clearance Distance

When replacing primary circuit components, confirm specified clearance distance (d) and (d') between soldered terminals, and between terminals and surrounding metallic parts. (See Fig. 1)

Table 1 : Ratings for selected area

AC Line Voltage	Clearance Distance (d), (d')
200 to 240 V	$\geq 3 \text{ mm}(d)$ $\geq 6 \text{ mm}(d')$

Note: This table is unofficial and for reference only. Be sure to confirm the precise values.

2. Leakage Current Test

Confirm the specified (or lower) leakage current between B (earth ground, power cord plug prongs) and externally exposed accessible parts (RF terminals, antenna terminals, video and audio input and output terminals, microphone jacks, earphone jacks, etc.) is lower than or equal to the specified value in the table below.

Measuring Method (Power ON) :

Insert load Z between B (earth ground, power cord plug prongs) and exposed accessible parts. Use an AC voltmeter to measure across the terminals of load Z. See Fig. 2 and the following table.

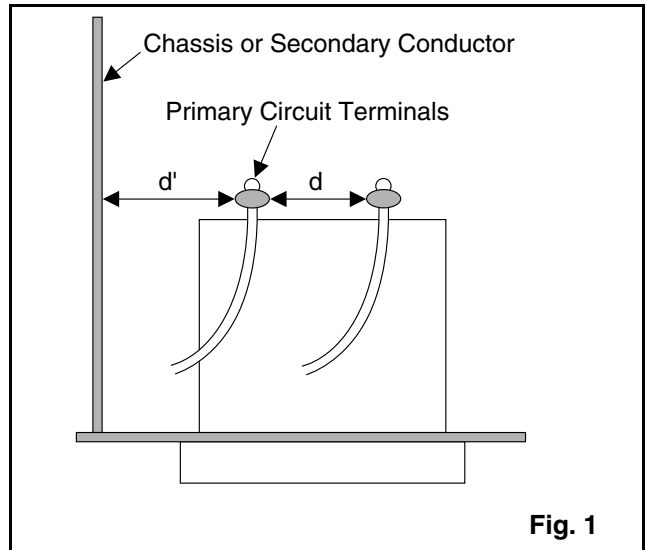

Fig. 1

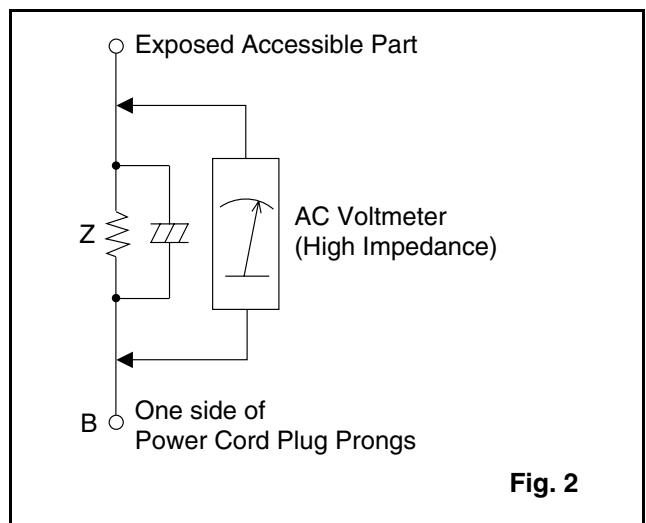

Fig. 2

Table 2: Leakage current ratings for selected areas

AC Line Voltage	Load Z	Leakage Current (i)	One side of power cord plug prongs (B) to:
200 to 240 V	2kΩ RES. Connected in parallel	$i \leq 0.7 \text{ mA AC Peak}$ $i \leq 2 \text{ mA DC}$	RF or Antenna terminals
	50kΩ RES. Connected in parallel	$i \leq 0.7 \text{ mA AC Peak}$ $i \leq 2 \text{ mA DC}$	A/V Input, Output

Note: This table is unofficial and for reference only. Be sure to confirm the precise values.

STANDARD NOTES FOR SERVICING

Circuit Board Indications

1. The output pin of the 3 pin Regulator ICs is indicated as shown.

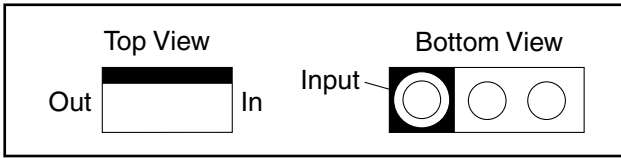

2. For other ICs, pin 1 and every fifth pin are indicated as shown.

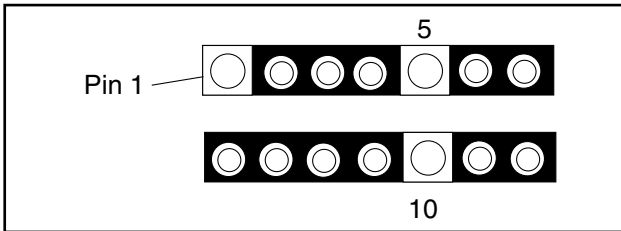

3. The 1st pin of every male connector is indicated as shown.

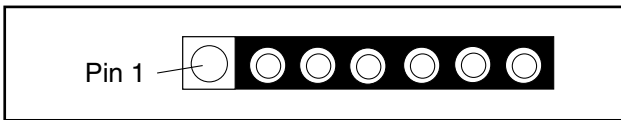

Instructions for Connectors

1. When you connect or disconnect the FFC (Flexible Foil Connector) cable, be sure to first disconnect the AC cord.
2. FFC (Flexible Foil Connector) cable should be inserted parallel into the connector, not at an angle.

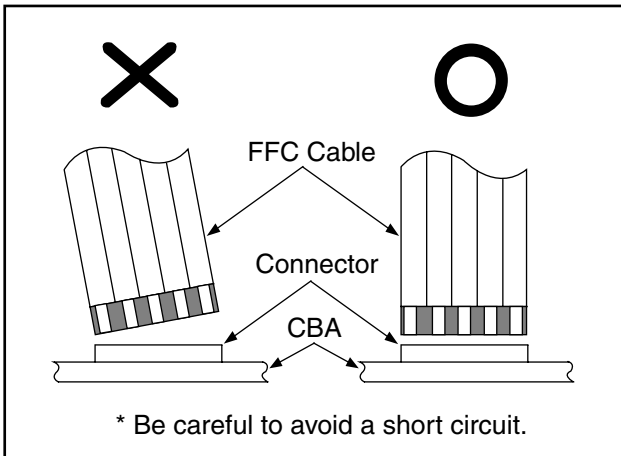

Pb (Lead) Free Solder

When soldering, be sure to use the Pb free solder.

How to Remove / Install Flat Pack-IC

1. Removal

With Hot-Air Flat Pack-IC Desoldering Machine:

1. Prepare the hot-air flat pack-IC desoldering machine, then apply hot air to the Flat Pack-IC (about 5 to 6 seconds). (Fig. S-1-1)

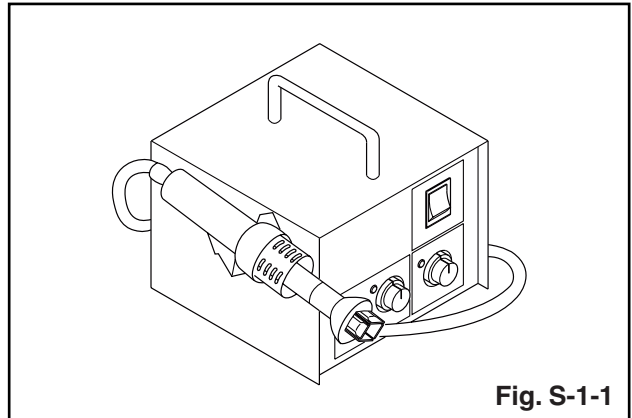

Fig. S-1-1

2. Remove the flat pack-IC with tweezers while applying the hot air.
3. Bottom of the flat pack-IC is fixed with glue to the CBA; when removing entire flat pack-IC, first apply soldering iron to center of the flat pack-IC and heat up. Then remove (glue will be melted). (Fig. S-1-6)
4. Release the flat pack-IC from the CBA using tweezers. (Fig. S-1-6)

CAUTION:

1. The Flat Pack-IC shape may differ by models. Use an appropriate hot-air flat pack-IC desoldering machine, whose shape matches that of the Flat Pack-IC.
2. Do not supply hot air to the chip parts around the flat pack-IC for over 6 seconds because damage to the chip parts may occur. Put masking tape around the flat pack-IC to protect other parts from damage. (Fig. S-1-2)

3. The flat pack-IC on the CBA is affixed with glue, so be careful not to break or damage the foil of each pin or the solder lands under the IC when removing it.

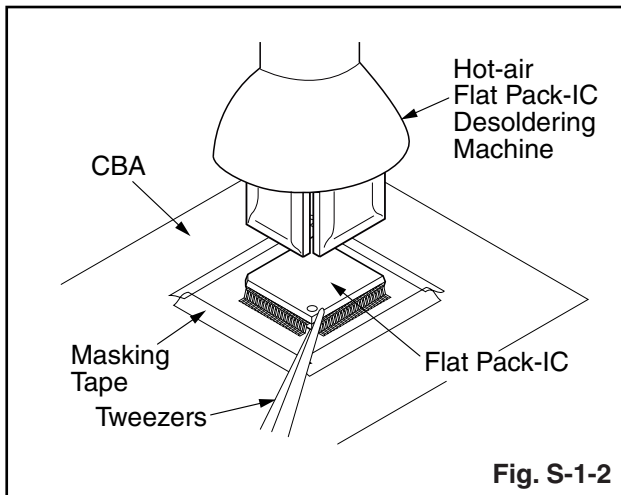

With Soldering Iron:

1. Using desoldering braid, remove the solder from all pins of the flat pack-IC. When you use solder flux which is applied to all pins of the flat pack-IC, you can remove it easily. (Fig. S-1-3)

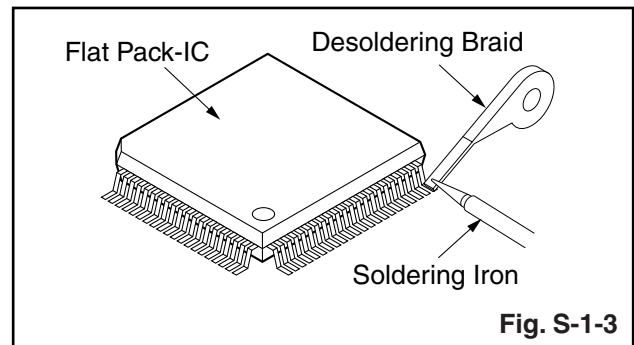

2. Lift each lead of the flat pack-IC upward one by one, using a sharp pin or wire to which solder will not adhere (iron wire). When heating the pins, use a fine tip soldering iron or a hot air desoldering machine. (Fig. S-1-4)

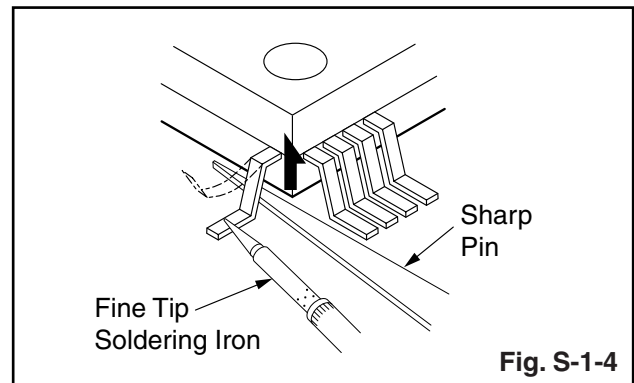

3. Bottom of the flat pack-IC is fixed with glue to the CBA; when removing entire flat pack-IC, first apply soldering iron to center of the flat pack-IC and heat up. Then remove (glue will be melted). (Fig. S-1-6)
4. Release the flat pack-IC from the CBA using tweezers. (Fig. S-1-6)

With Iron Wire:

1. Using desoldering braid, remove the solder from all pins of the flat pack-IC. When you use solder flux which is applied to all pins of the flat pack-IC, you can remove it easily. (Fig. S-1-3)
2. Affix the wire to a workbench or solid mounting point, as shown in Fig. S-1-5.
3. While heating the pins using a fine tip soldering iron or hot air blower, pull up the wire as the solder melts so as to lift the IC leads from the CBA contact pads as shown in Fig. S-1-5.
4. Bottom of the flat pack-IC is fixed with glue to the CBA; when removing entire flat pack-IC, first apply soldering iron to center of the flat pack-IC and heat up. Then remove (glue will be melted). (Fig. S-1-6)
5. Release the flat pack-IC from the CBA using tweezers. (Fig. S-1-6)

Note: When using a soldering iron, care must be taken to ensure that the flat pack-IC is not being held by glue. When the flat pack-IC is removed from the CBA, handle it gently because it may be damaged if force is applied.

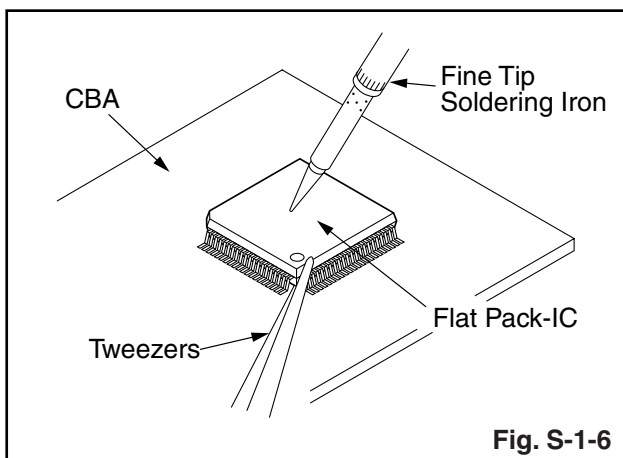
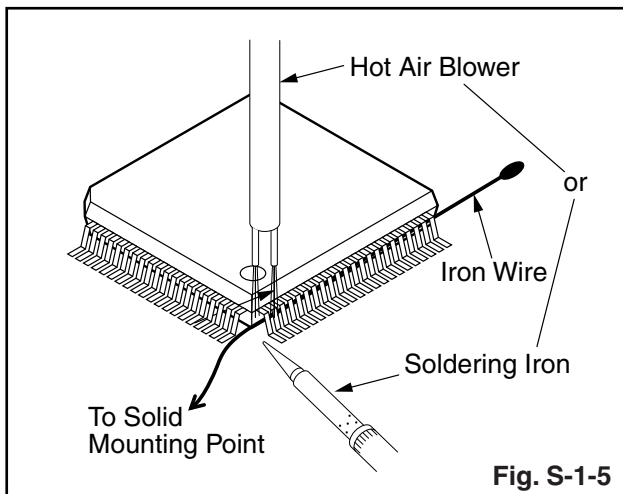

2. Installation

1. Using desoldering braid, remove the solder from the foil of each pin of the flat pack-IC on the CBA so you can install a replacement flat pack-IC more easily.
2. The "●" mark on the flat pack-IC indicates pin 1. (See Fig. S-1-7.) Be sure this mark matches the 1 on the PCB when positioning for installation. Then presolder the four corners of the flat pack-IC. (See Fig. S-1-8.)
3. Solder all pins of the flat pack-IC. Be sure that none of the pins have solder bridges.

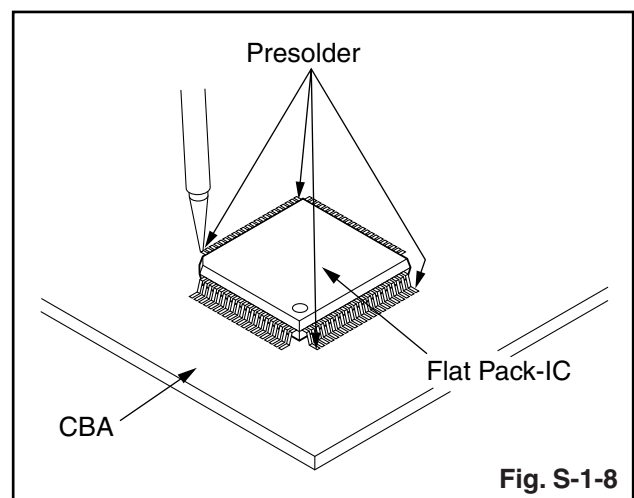
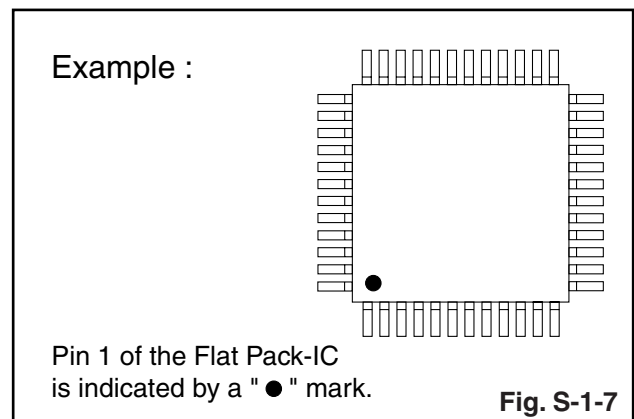

Instructions for Handling Semi-conductors

Electrostatic breakdown of the semi-conductors may occur due to a potential difference caused by electrostatic charge during unpacking or repair work.

1. Ground for Human Body

Be sure to wear a grounding band ($1\text{ M}\Omega$) that is properly grounded to remove any static electricity that may be charged on the body.

2. Ground for Workbench

Be sure to place a conductive sheet or copper plate with proper grounding ($1\text{ M}\Omega$) on the workbench or other surface, where the semi-conductors are to be placed. Because the static electricity charge on clothing will not escape through the body grounding band, be careful to avoid contacting semi-conductors with your clothing.

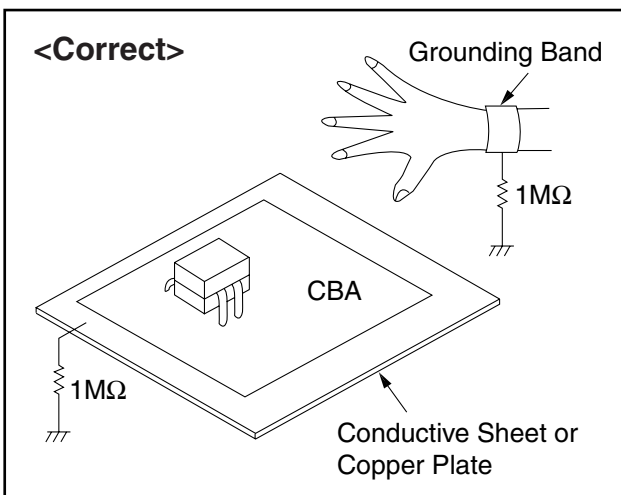
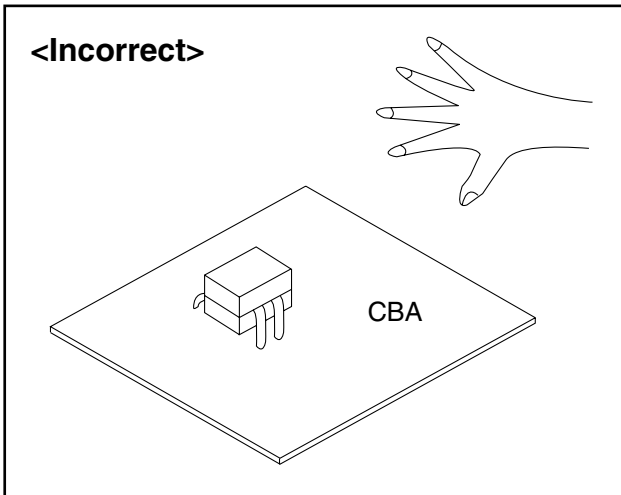

CABINET DISASSEMBLY INSTRUCTIONS

1. Disassembly Flowchart

This flowchart indicates the disassembly steps to gain access to item(s) to be serviced. When reassembling, follow the steps in reverse order. Bend, route, and dress the cables as they were originally.

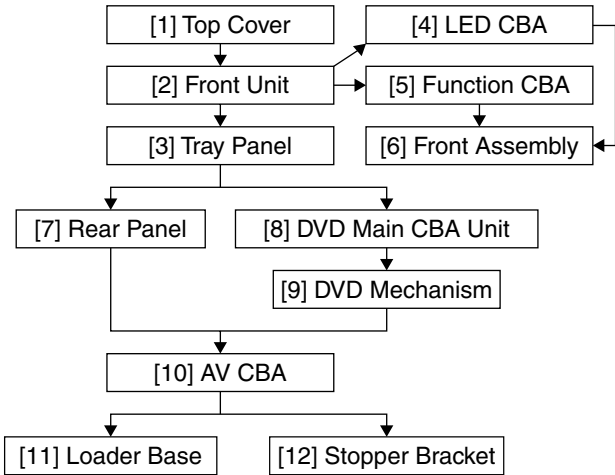

2. Disassembly Method

ID/ Loc. No.	Part	Removal		
		Fig. No.	Remove/*Unhook/ Unlock/Release/ Unplug/Desolder	Note
[1]	Top Cover	D1	5(S-1)	---
[2]	Front Unit	D2	*2(L-1), *2(L-2), *3(L-3), *CN2001, *CN2002	1
[3]	Tray Panel	D2	*2(L-4)	1
[4]	LED CBA	D3	2(S-2)	---
[5]	Function CBA	D3	3(S-3)	---
[6]	Front Assembly	D3	-----	---
[7]	Rear Panel	D4	8(S-4), (S-5)	---
[8]	DVD Main CBA Unit	D5	(S-6A), (S-6B), *CN201, *CN301, *CN401, *CN601	2
[9]	DVD Mechanism	D5 D6	4(S-7)	2 3
[10]	AV CBA	D7	4(S-8), (S-9)	---
[11]	Loader Base	D8	4(S-10)	---
[12]	Stopper Bracket	D8	(S-11)	---

↓ (1) ↓ (2) ↓ (3) ↓ (4) ↓ (5)

Note:

- (1) Identification (location) No. of parts in the figures
- (2) Name of the part
- (3) Figure Number for reference

- (4) Identification of parts to be removed, unhooked, unlocked, released, unplugged, unclamped, or desoldered.

P = Spring, L = Locking Tab, S = Screw,
CN = Connector

* = Unhook, Unlock, Release, Unplug, or Desolder
e.g. 2(S-2) = two Screws (S-2),
2(L-2) = two Locking Tabs (L-2)

- (5) Refer to "Reference Notes."

About tightening screws

When tightening screws, tighten them with the following torque.

Screws	Torque
(S-1), (S-2), (S-3), (S-4), (S-5), (S-6A), (S-7), (S-8), (S-9), (S-10), (S-11)	0.45 ± 0.05 N·m
(S-6B)	0.38 ± 0.04 N·m

Reference Notes

- CAUTION 1:** Locking Tabs (L-1), (L-2), (L-3) and (L-4) are fragile. Be careful not to break them.
 - 1) Release two Locking Tabs (L-1), then release two Locking Tabs (L-2).
 - 2) Release three Locking Tabs (L-3).
 - 3) Disconnect connectors CN2001 and CN2002, and remove the Front Unit.
- CAUTION 2:** Electrostatic breakdown of the laser diode in the optical system block may occur as a potential difference caused by electrostatic charge accumulated on cloth, human body etc, during unpacking or repair work.
To avoid damage of pickup follow next procedures.
 - 1) Short the three short lands of FPC cable with solder before removing the FFC cable (CN201) from it. If you disconnect the FFC cable (CN201), the laser diode of pickup will be destroyed. (Fig. D5)
 - 2) Disconnect Connectors (CN301), (CN401) and (CN601). Remove two Screws (S-6A) and (S-6B) and lift the DVD Main CBA Unit. (Fig. D5)
- CAUTION 3:** When reassembling, confirm the FFC cable (CN201) is connected completely. Then remove the solder from the three short lands of FPC cable. (Fig. D5)

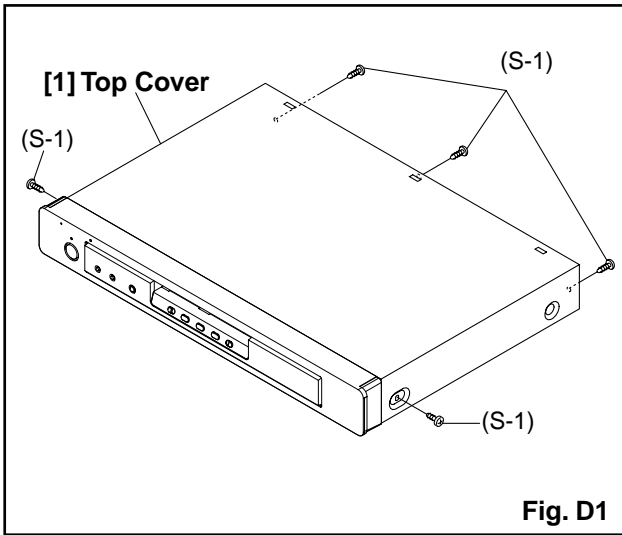

Fig. D1

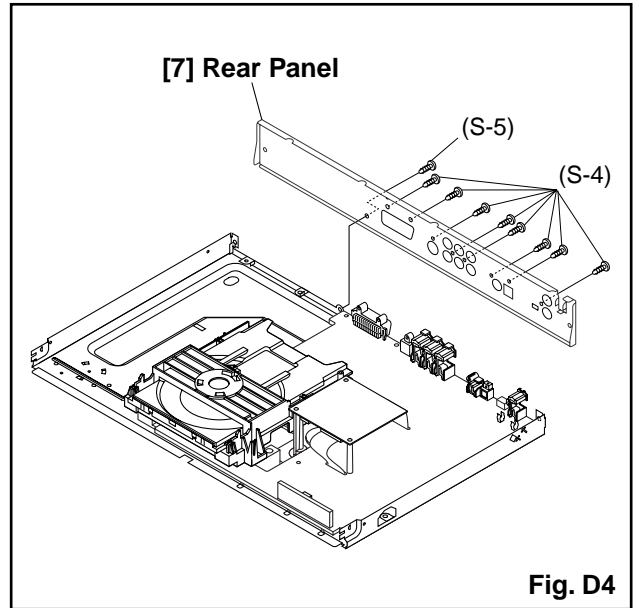

Fig. D4

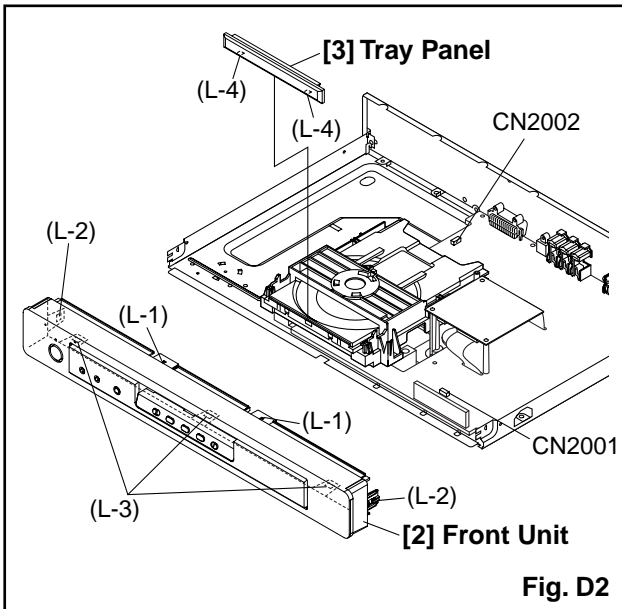

Fig. D2

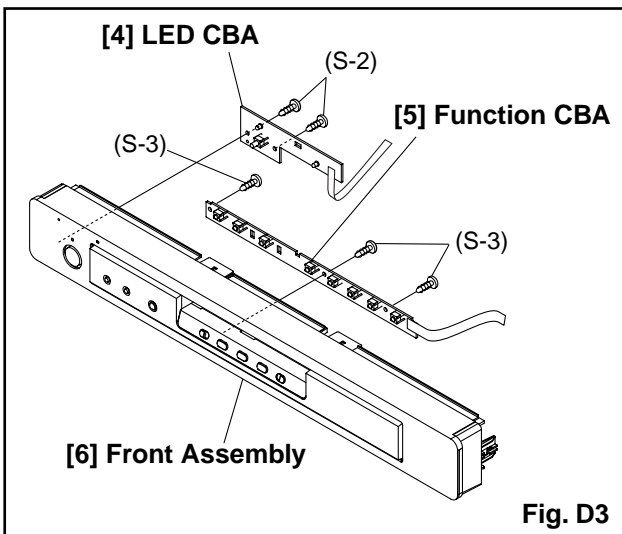
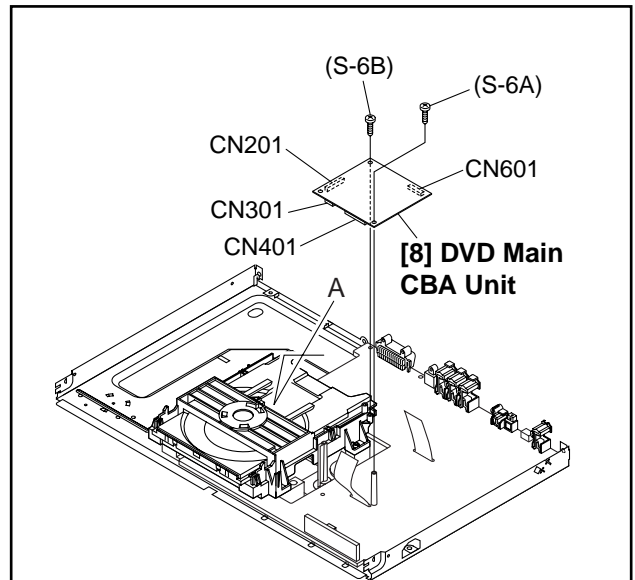
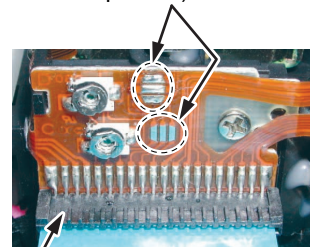

Fig. D3

Short the three short lands by soldering.
(Either of two places.)



Connector View for A

Fig. D5

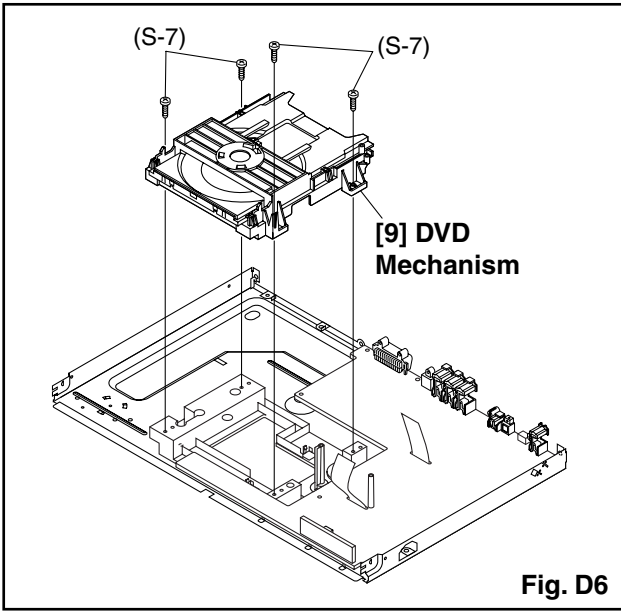

Fig. D6

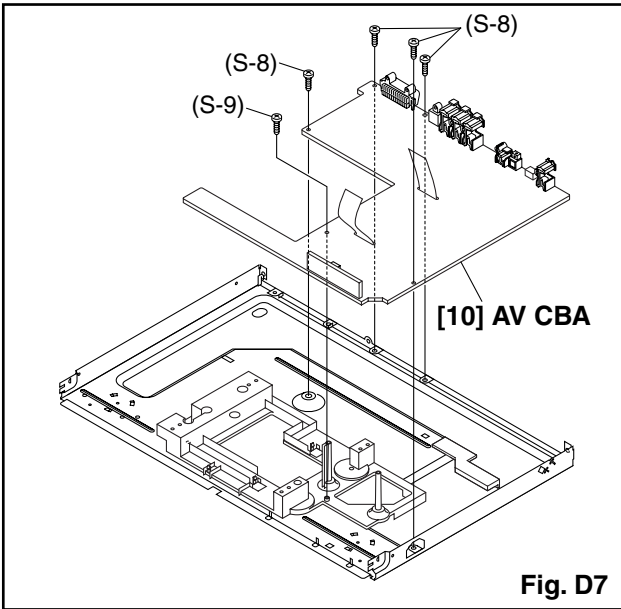

Fig. D7

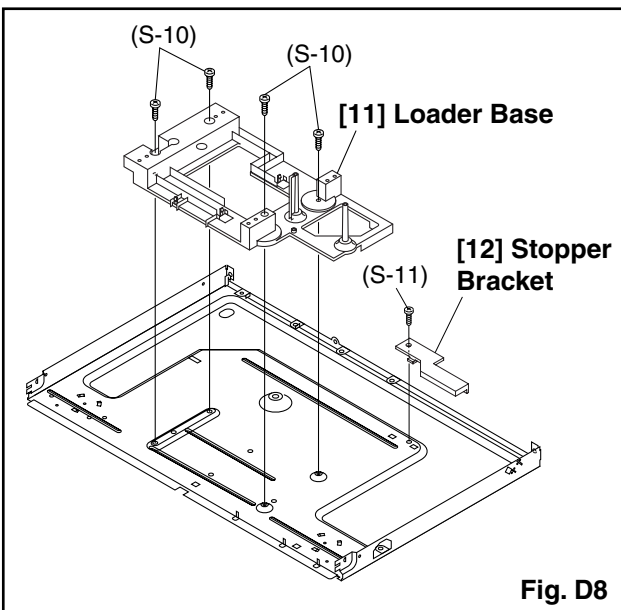
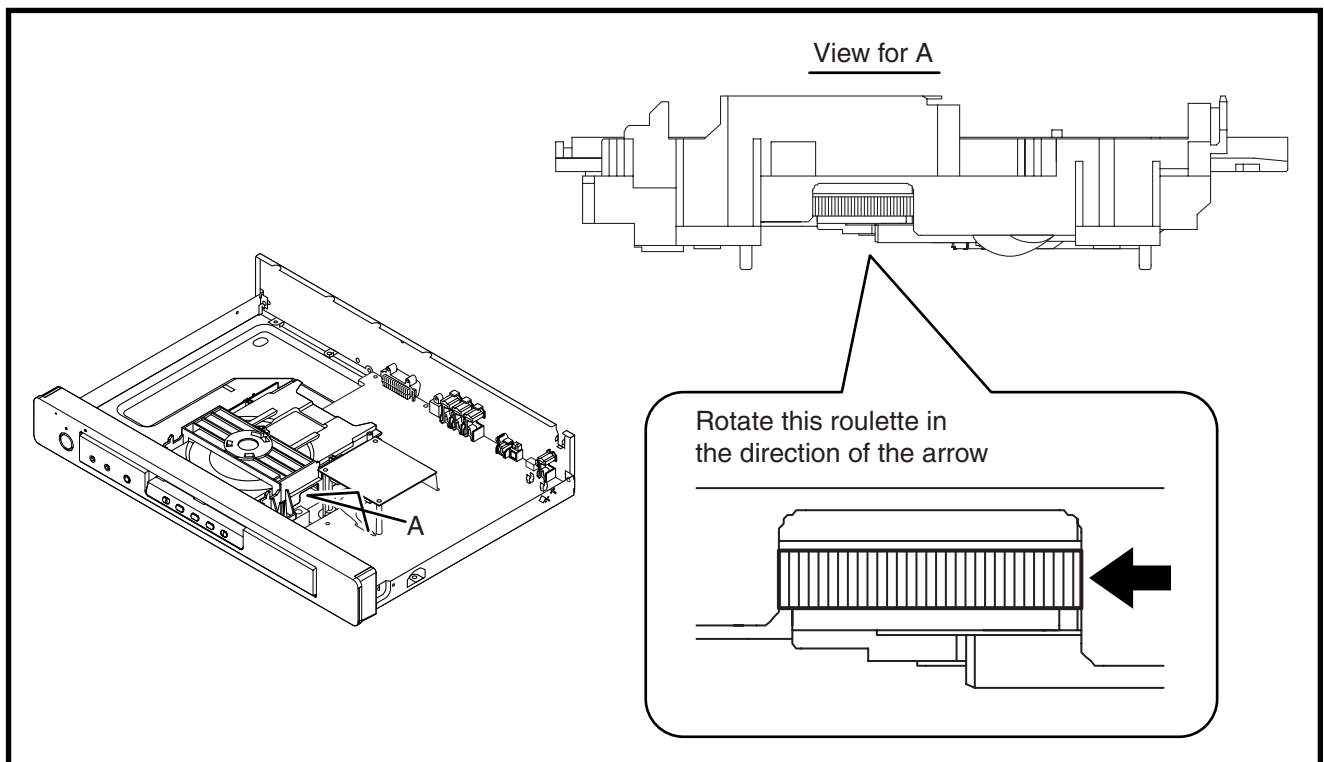

Fig. D8

3. How to Eject Manually

1. Remove the Top Cover.
2. Rotate the roulette in the direction of the arrow as shown below.



HOW TO INITIALIZE THE DVD PLAYER

To put the program back at the factory-default, initialize the DVD player as the following procedure.

1. Press [1], [2], [3], [4], and [DISPLAY] buttons on the remote control unit in that order.

Fig. a appears on the screen.

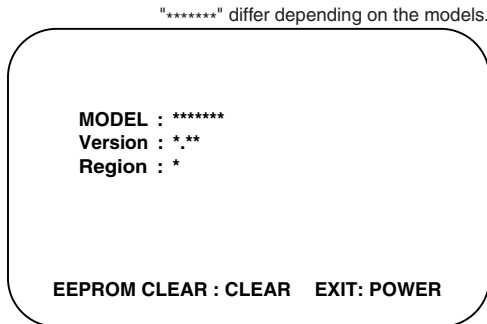

Fig. a

2. Press [CLEAR] button on the remote control unit.

Fig. b appears on the screen.

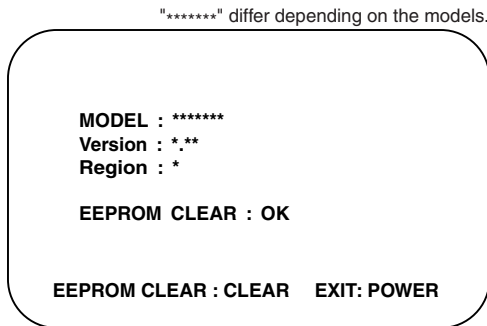

Fig. b

When "OK" appears on the screen, the factory default will be set. Then the firmware renewal mode is complete.

3. To exit this mode, press [POWER] button.

FIRMWARE RENEWAL MODE

1. Turn the power on and remove the disc on the tray.
2. To put the DVD player into version up mode, press [9], [8], [7], [6], and [SEARCH MODE] buttons on the remote control unit in that order. The tray will open automatically.

Fig. a appears on the screen and Fig. b appears on the VFD.

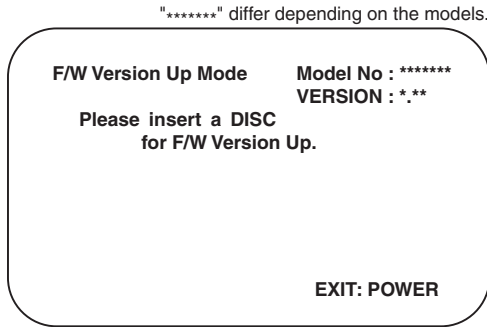

Fig. a Version Up Mode Screen

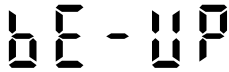

Fig. b VFD in Version Up Mode

The DVD player can also enter the version up mode with the tray open. In this case, Fig. a will be shown on the screen while the tray is open.

3. Load the disc for version up.
4. The DVD player enters the F/W version up mode automatically. Fig. c appears on the screen and Fig. d appears on the VFD. If you enter the F/W for different models, "Disc Error" will appear on the screen, then the tray will open automatically.

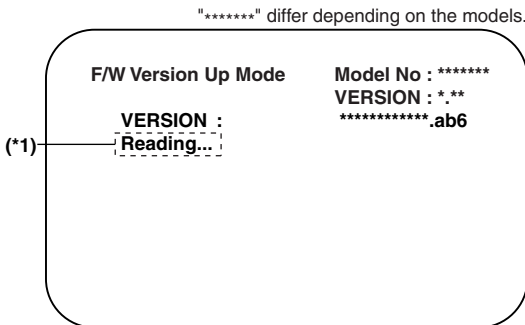

Fig. c Programming Mode Screen



Fig. d VFD in Programming Mode (Example)

The appearance shown in (*1) of Fig. c is described as follows:

No.	Appearance	State
1	Reading...	Sending files into the memory
2	Erasing...	Erasing previous version data
3	Programming...	Writing new version data

5. After programming is finished, the tray opens automatically. Fig. e appears on the screen and the checksum in (*2) of Fig. e appears on the VFD (Fig. f).

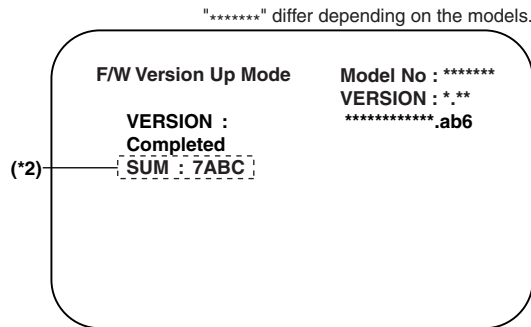

Fig. e Completed Program Mode Screen



Fig. f VFD upon Finishing the Programming Mode (Example)

At this time, no button is available.

6. Remove the disc on the tray.
7. Unplug the AC cord from the AC outlet. Then plug it again.
8. Turn the power on by pressing the [POWER] button and the tray will close.
9. Press [1], [2], [3], [4], and [DISPLAY] buttons on the remote control unit in that order. Fig. g appears on the screen.

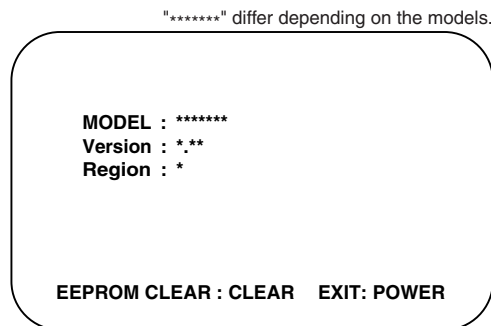

Fig. g

10. Press [CLEAR] button on the remote control unit. Fig. h appears on the screen.

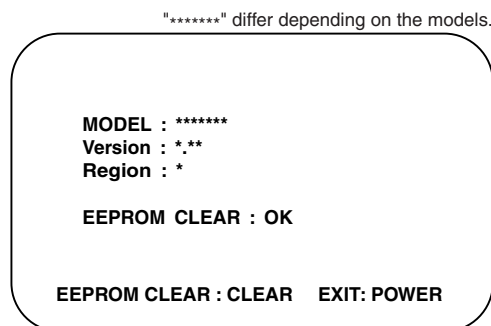

Fig. h

When "OK" appears on the screen, the factory default will be set. Then the firmware renewal mode is complete.

11. To exit this mode, press [POWER] button.

TROUBLESHOOTING

FLOW CHART NO.1

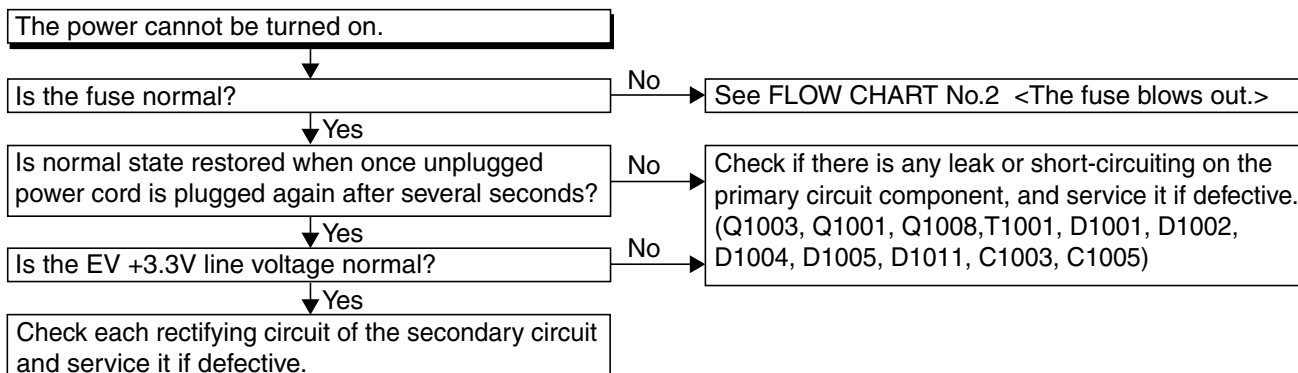

FLOW CHART NO.2

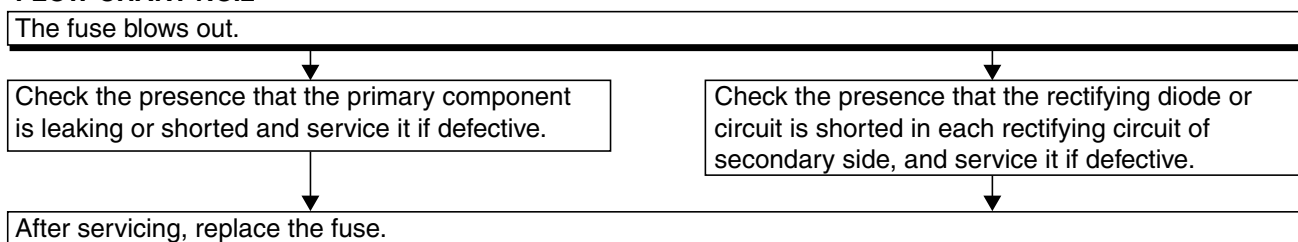

FLOW CHART NO.3

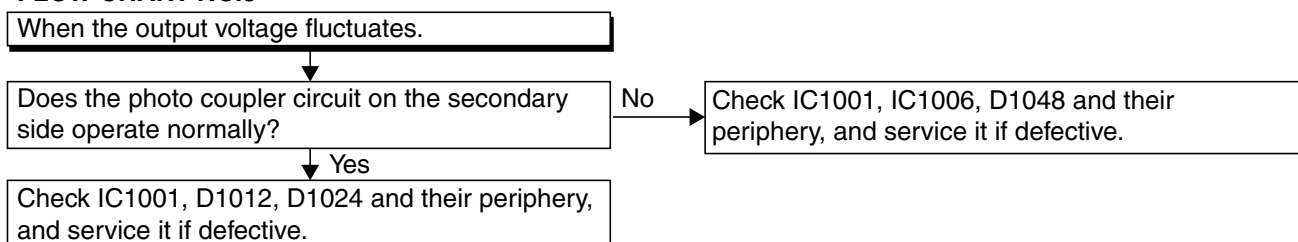

FLOW CHART NO.4

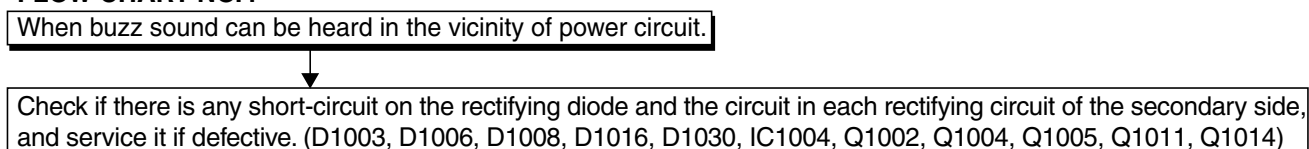

FLOW CHART NO.5

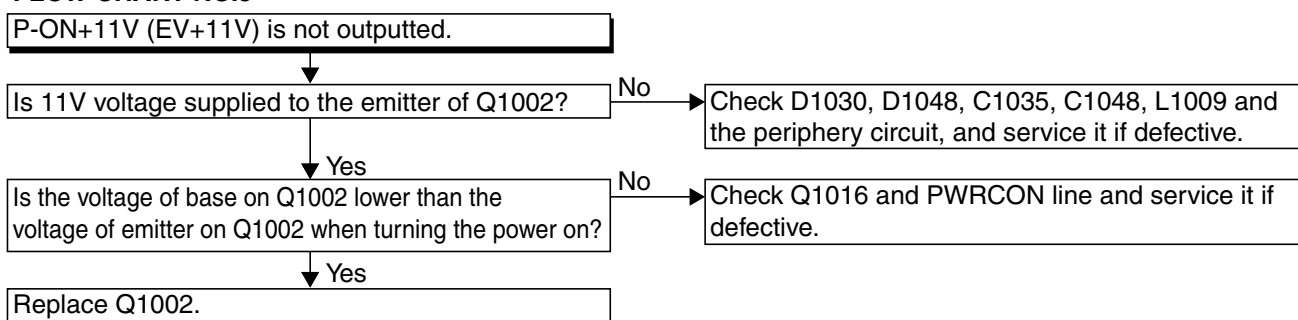

FLOW CHART NO.6

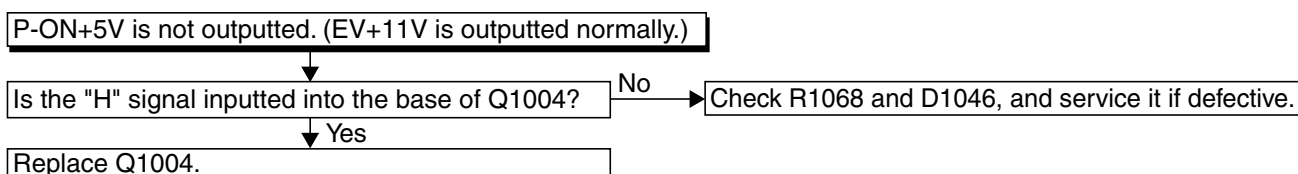

FLOW CHART NO.7

P-ON+3.3V is not outputted. (P-ON+11V is outputted normally.)

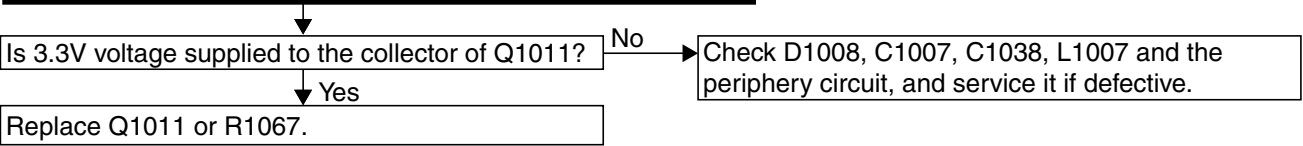

FLOW CHART NO.8

EV+5V is not outputted.

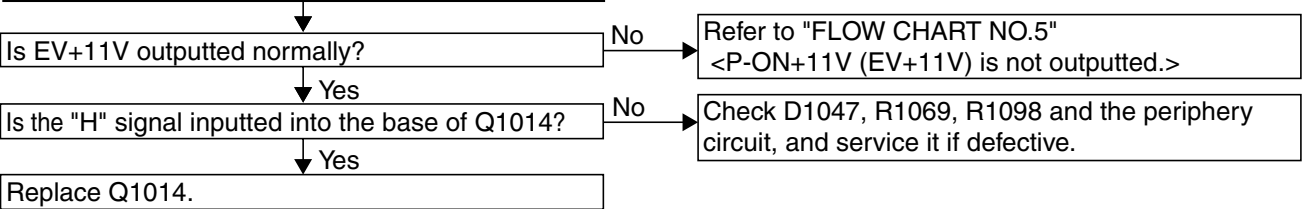

FLOW CHART NO.9

EV+1.2V is not outputted.

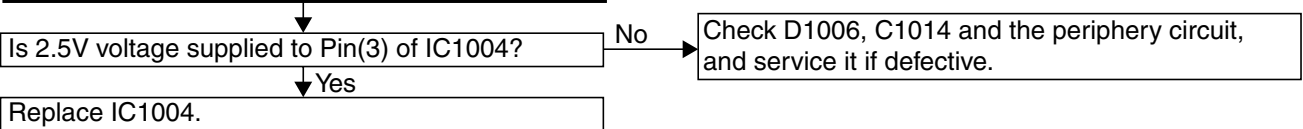

FLOW CHART NO.10

The fluorescent display tube does not light up.

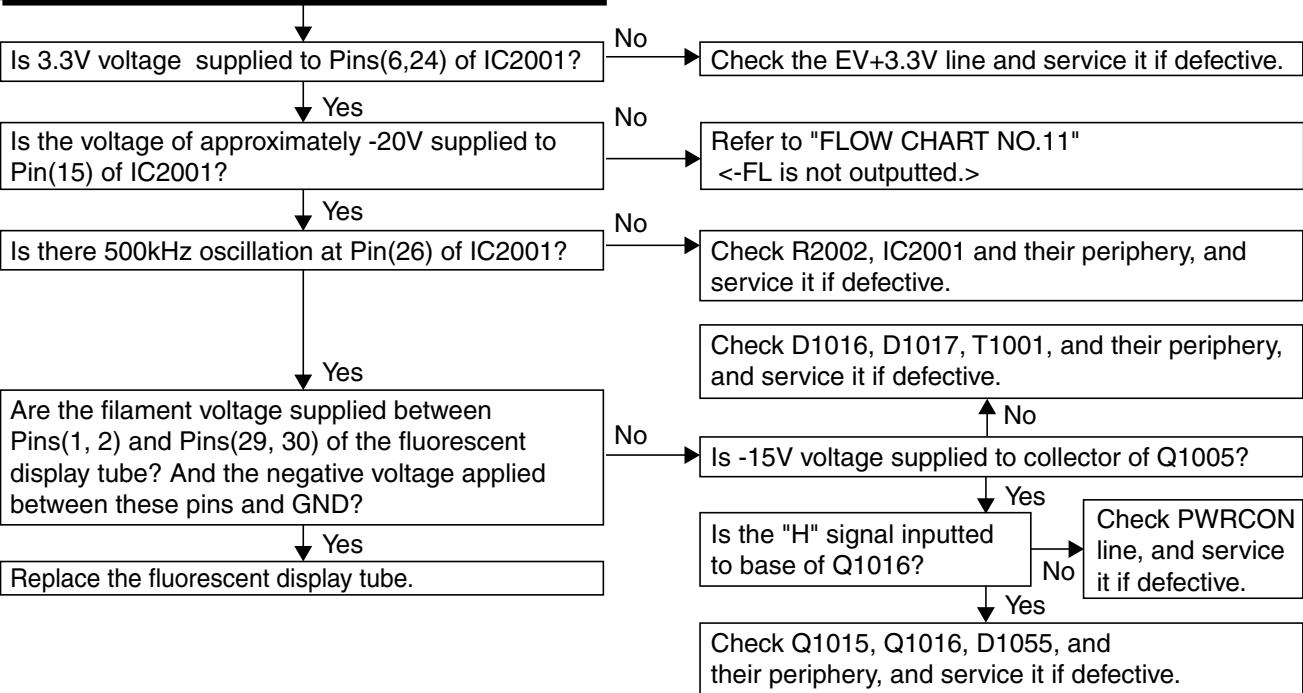

FLOW CHART NO.11

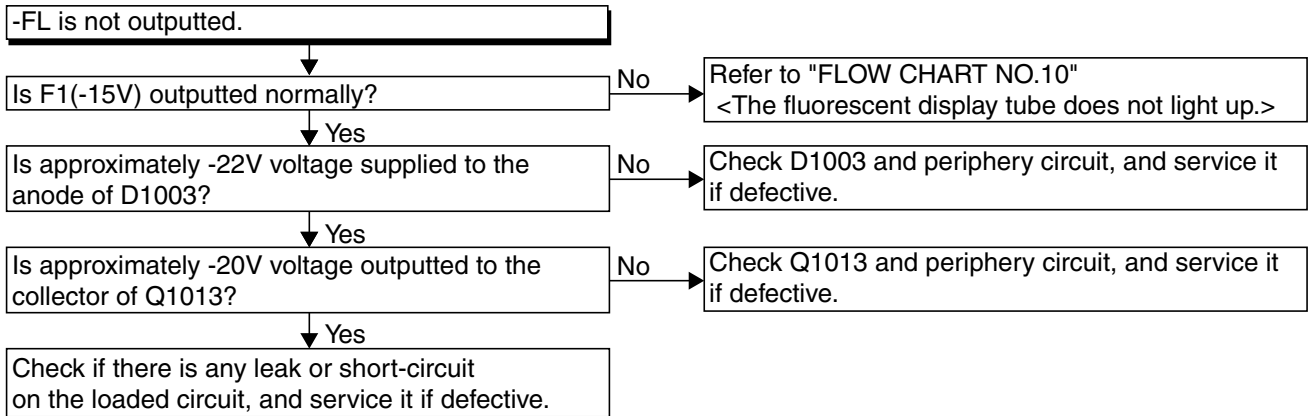

FLOW CHART NO.12

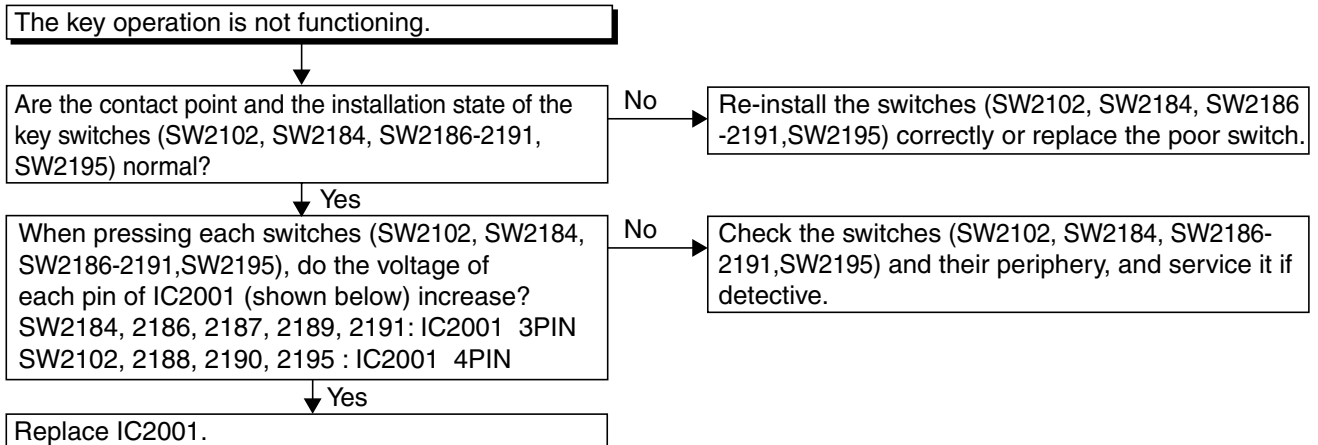

FLOW CHART NO.13

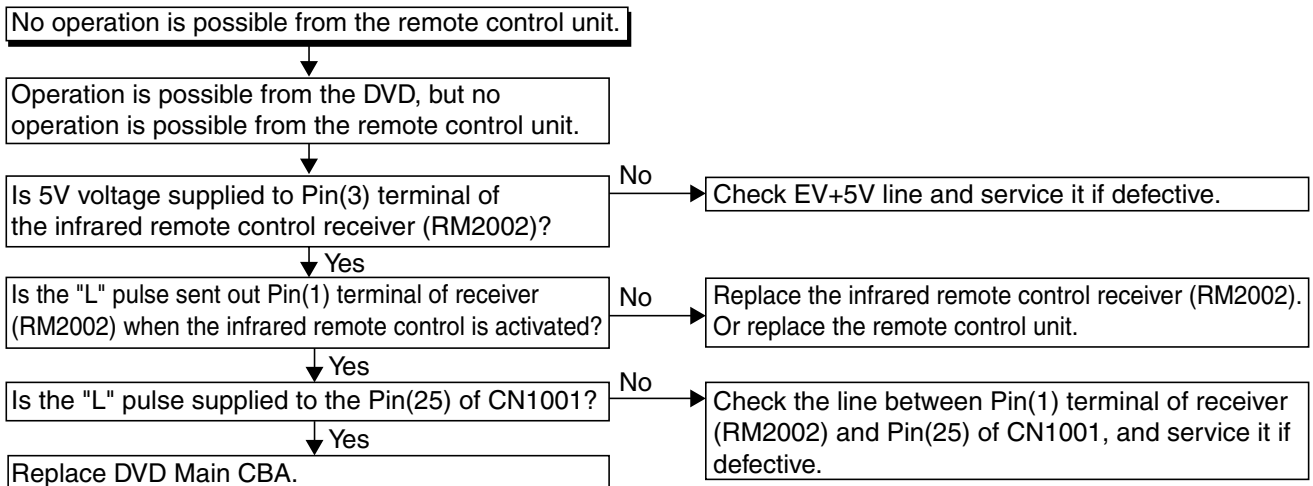

FLOW CHART NO.14

The disc tray cannot be opened and closed. (It can be done using the remote control unit.)

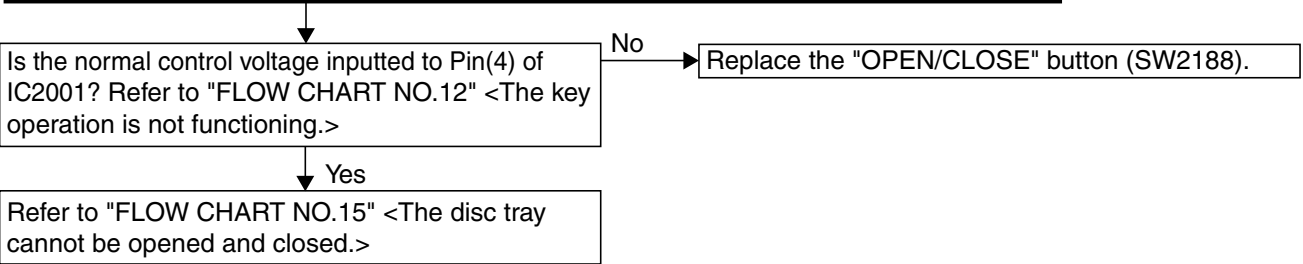

FLOW CHART NO.15

The disc tray cannot be opened and closed.

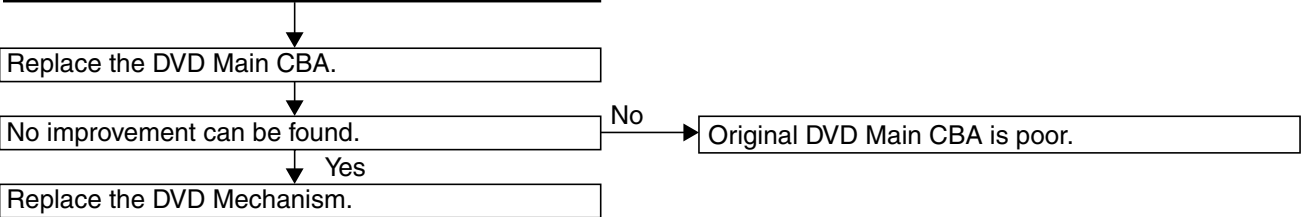

FLOW CHART NO.16

[No Disc] indicated. (When the focus error occurs.)

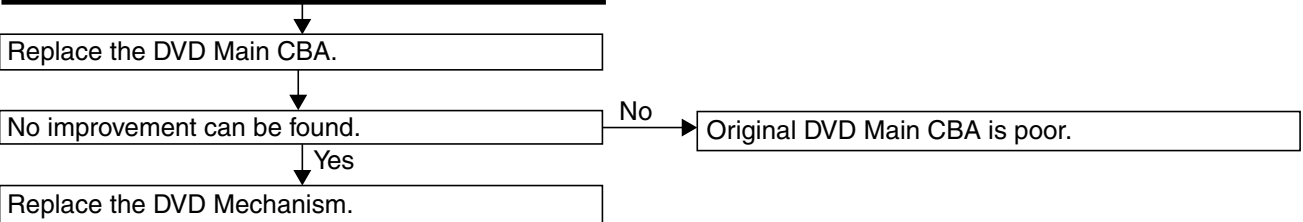

FLOW CHART NO.17

[No Disc] indicated. (When the focus servo is not functioning.)

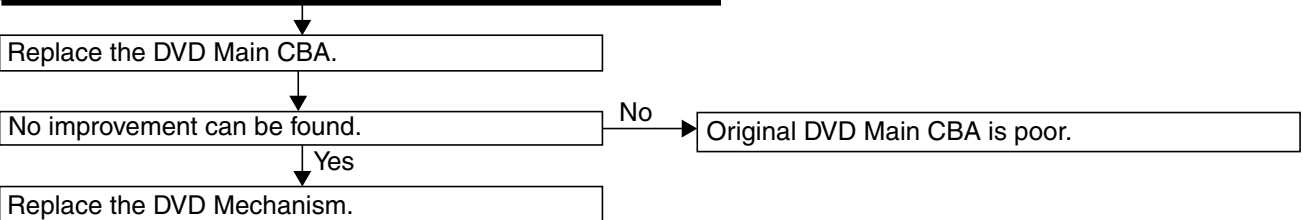

FLOW CHART NO.18

[No Disc] indicated. (When the laser beam does not light up.)

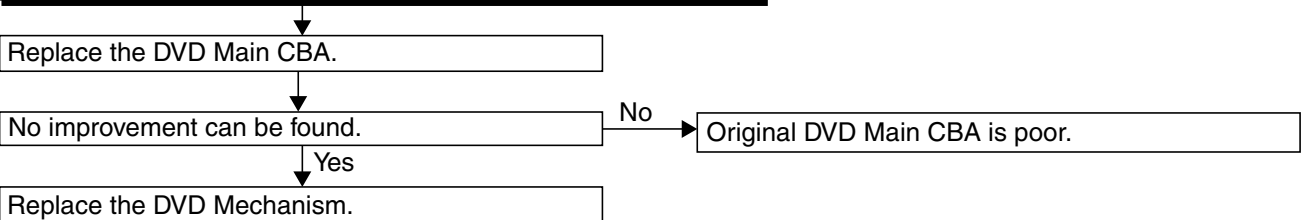

FLOW CHART NO.19

Both functions of picture and sound do not operate normally.

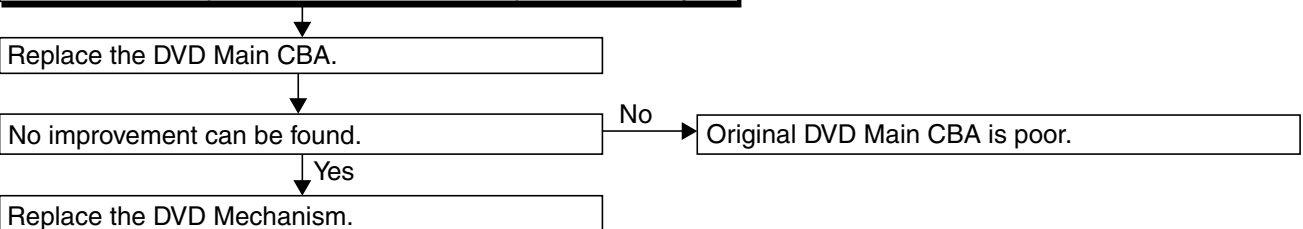

FLOW CHART NO.20

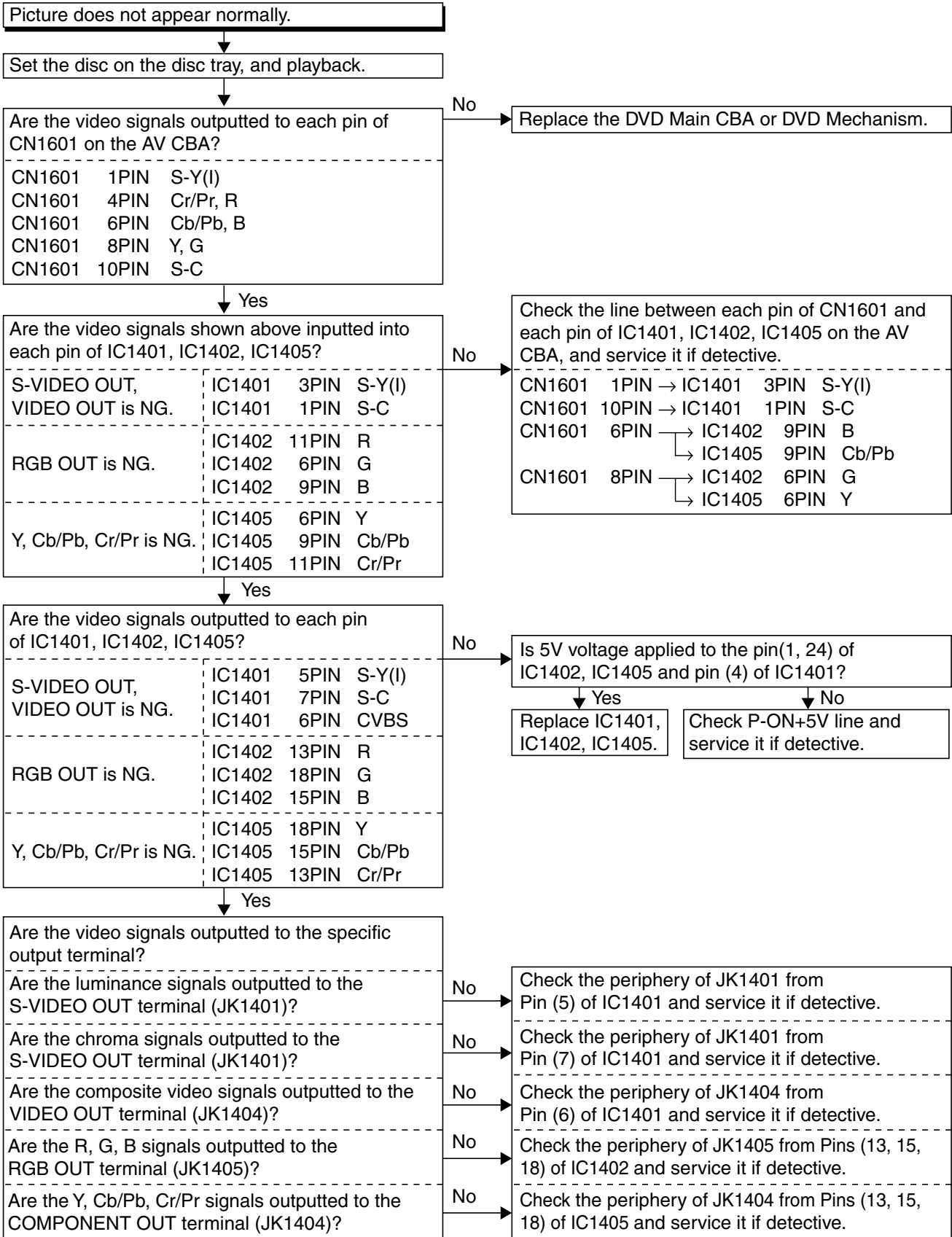

FLOW CHART NO.21

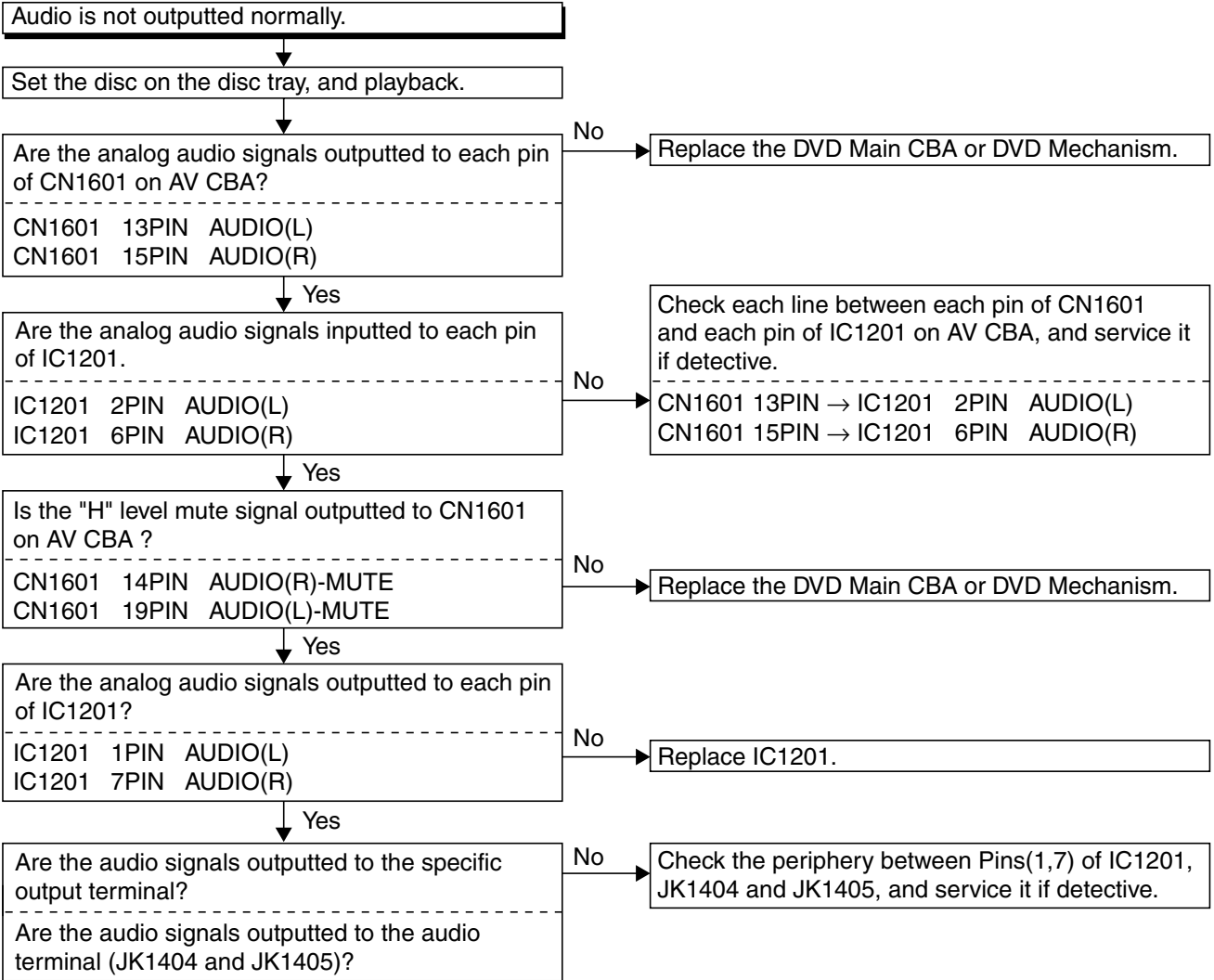

BLOCK DIAGRAMS

System Control / Servo Block Diagram

*1 NOTE:
Either IC461 or IC462 is used for DVD MAIN CBA UNIT.

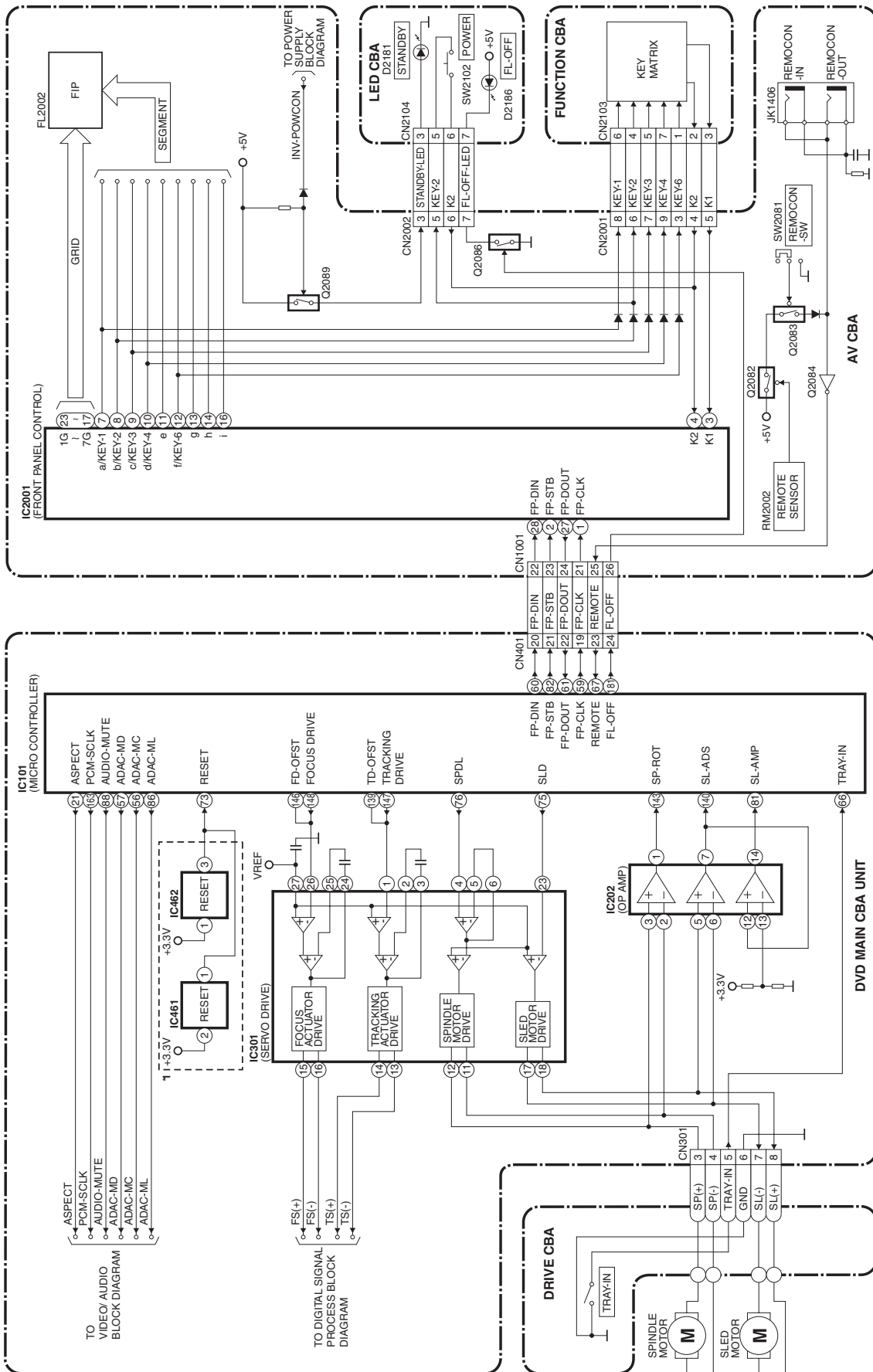

Digital Signal Process Block Diagram

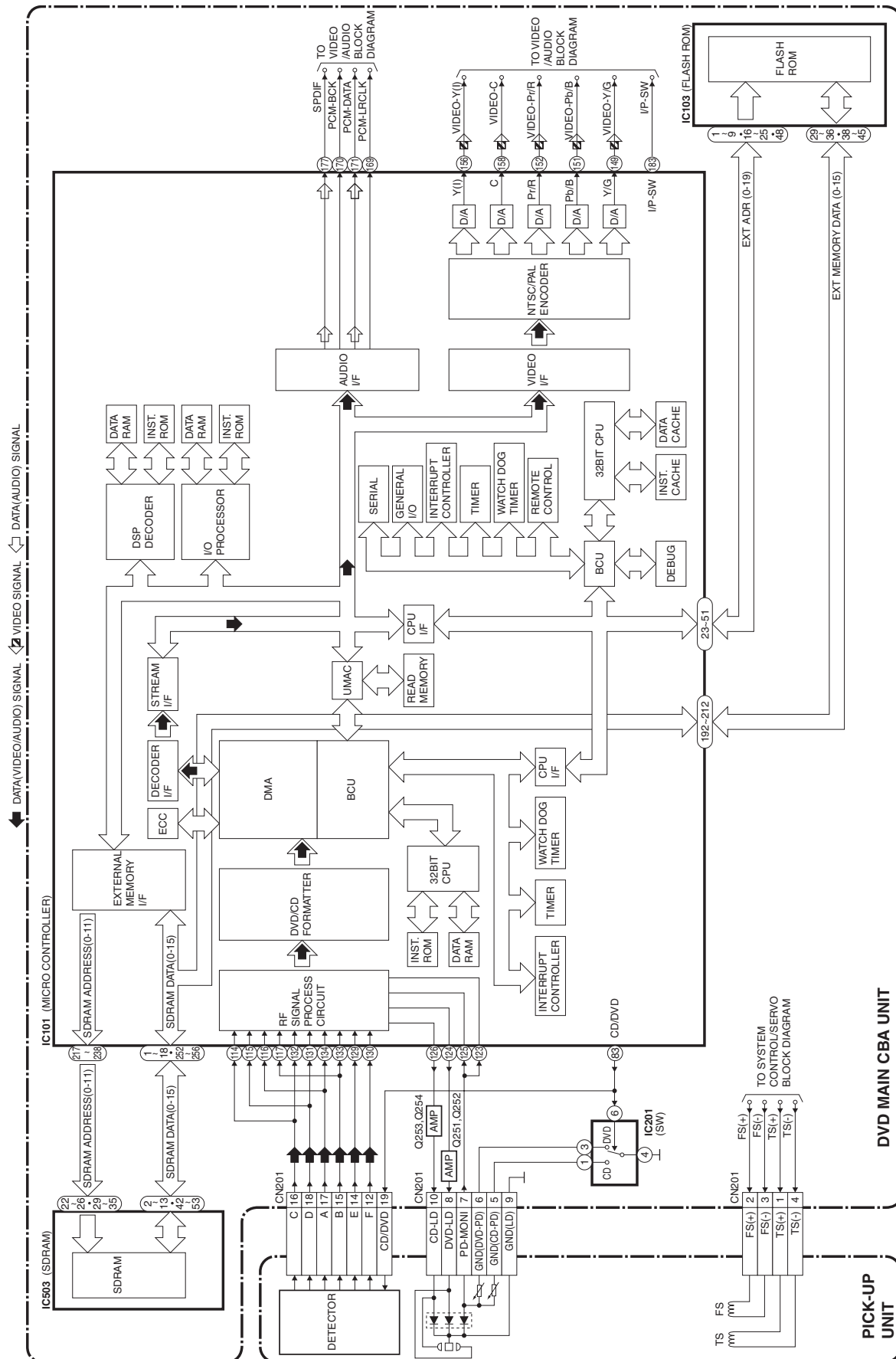

Video / Audio Block Diagram

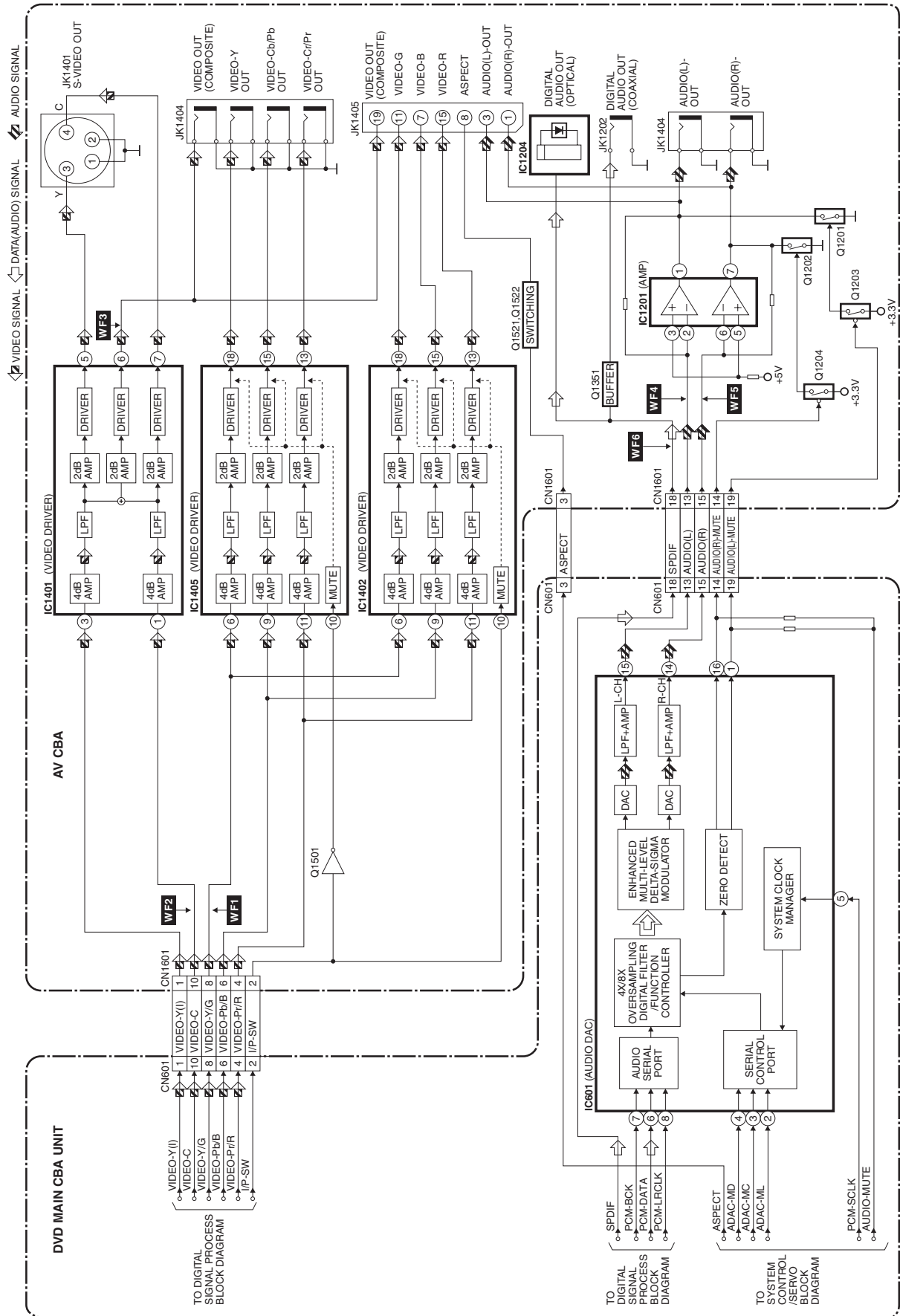

Power Supply Block Diagram

CAUTION !

Fixed voltage (or Auto voltage selectable) power supply circuit is used in this unit.
 If Main Fuse (F1001) is blown, check to see that all components in the power supply circuit are not defective before you connect the AC plug to the AC power supply.
 Otherwise it may cause some components in the power supply circuit to fail.

CAUTION !

For continued protection against fire hazard, replace only with the same type fuse.

NOTE:

The voltage for parts in hot circuit is measured using hot GND as a common terminal.

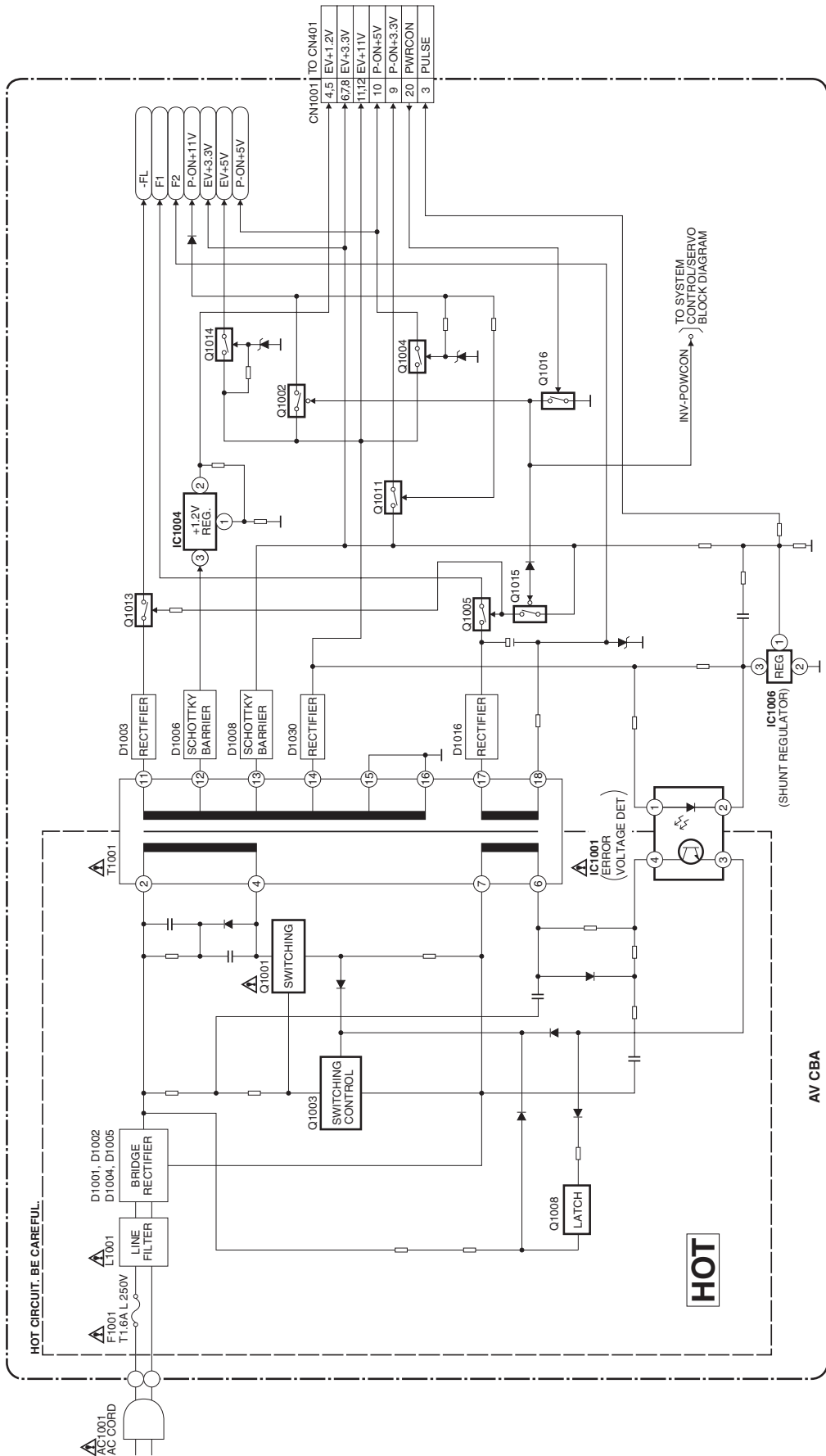

SCHEMATIC DIAGRAMS / CBA'S AND TEST POINTS

Standard Notes

WARNING

Many electrical and mechanical parts in this chassis have special characteristics. These characteristics often pass unnoticed and the protection afforded by them cannot necessarily be obtained by using replacement components rated for higher voltage, wattage, etc. Replacement parts that have these special safety characteristics are identified in this manual and its supplements; electrical components having such features are identified by the mark “ \triangle ” in the schematic diagram and the parts list. Before replacing any of these components, read the parts list in this manual carefully. The use of substitute replacement parts that do not have the same safety characteristics as specified in the parts list may create shock, fire, or other hazards.

Notes:

1. Do not use the part number shown on these drawings for ordering. The correct part number is shown in the parts list, and may be slightly different or amended since these drawings were prepared.
2. All resistance values are indicated in ohms ($K = 10^3$, $M = 10^6$).
3. Resistor wattages are 1/4W or 1/6W unless otherwise specified.
4. All capacitance values are indicated in μF ($P = 10^{-6} \mu F$).
5. All voltages are DC voltages unless otherwise specified.
6. Electrical parts such as capacitors, connectors, diodes, IC's, transistors, resistors, switches, and fuses are identified by four digits. The first two digits are not shown for each component. In each block of the diagram, there is a note such as shown below to indicate these abbreviated two digits.

LIST OF CAUTION, NOTES, AND SYMBOLS USED IN THE SCHEMATIC DIAGRAMS ON THE FOLLOWING PAGES:

1. CAUTION:

FOR CONTINUED PROTECTION AGAINST FIRE HAZARD, REPLACE ONLY WITH THE SAME TYPE FUSE.

2. CAUTION:

Fixed Voltage (or Auto voltage selectable) power supply circuit is used in this unit.

If Main Fuse (F1001) is blown, first check to see that all components in the power supply circuit are not defective before you connect the AC plug to the AC power supply. Otherwise it may cause some components in the power supply circuit to fail.

3. Note:

- Do not use the part number shown on the drawings for ordering. The correct part number is shown in the parts list, and may be slightly different or amended since the drawings were prepared.
- To maintain original function and reliability of repaired units, use only original replacement parts which are listed with their part numbers in the parts list section of the service manual.

4. Voltage indications for PLAY and STOP mode on the schematics are as shown below:

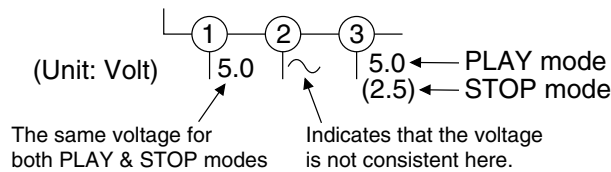

5. How to read converged lines

1-D3
 Distinction Area
 Line Number
 (1 to 3 digits)

Examples:

- "1-D3" means that line number "1" goes to the line number "1" of the area "D3".
- "1-B1" means that line number "1" goes to the line number "1" of the area "B1".

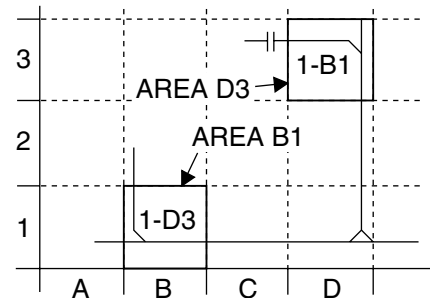

6. Test Point Information

: Indicates a test point with a jumper wire across a hole in the PCB.

: Used to indicate a test point with a component lead on foil side.

: Used to indicate a test point with no test pin.

: Used to indicate a test point with a test pin.

DVD Main 1/3 Schematic Diagram

***1 NOTE:**
Either IC461 or IC462 is used for DVD MAIN CBA UNIT.

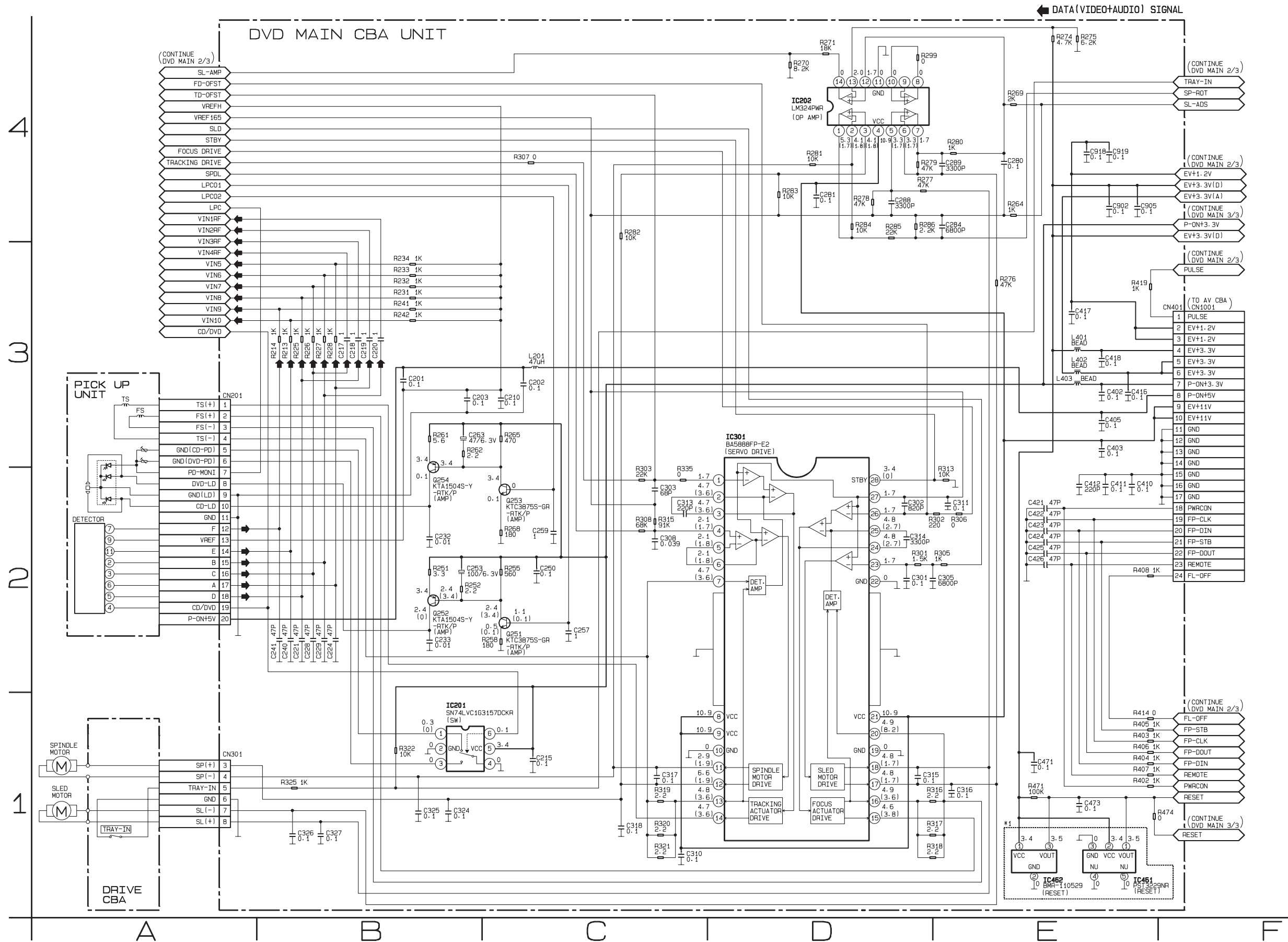

DVD Main 2/3 Schematic Diagram

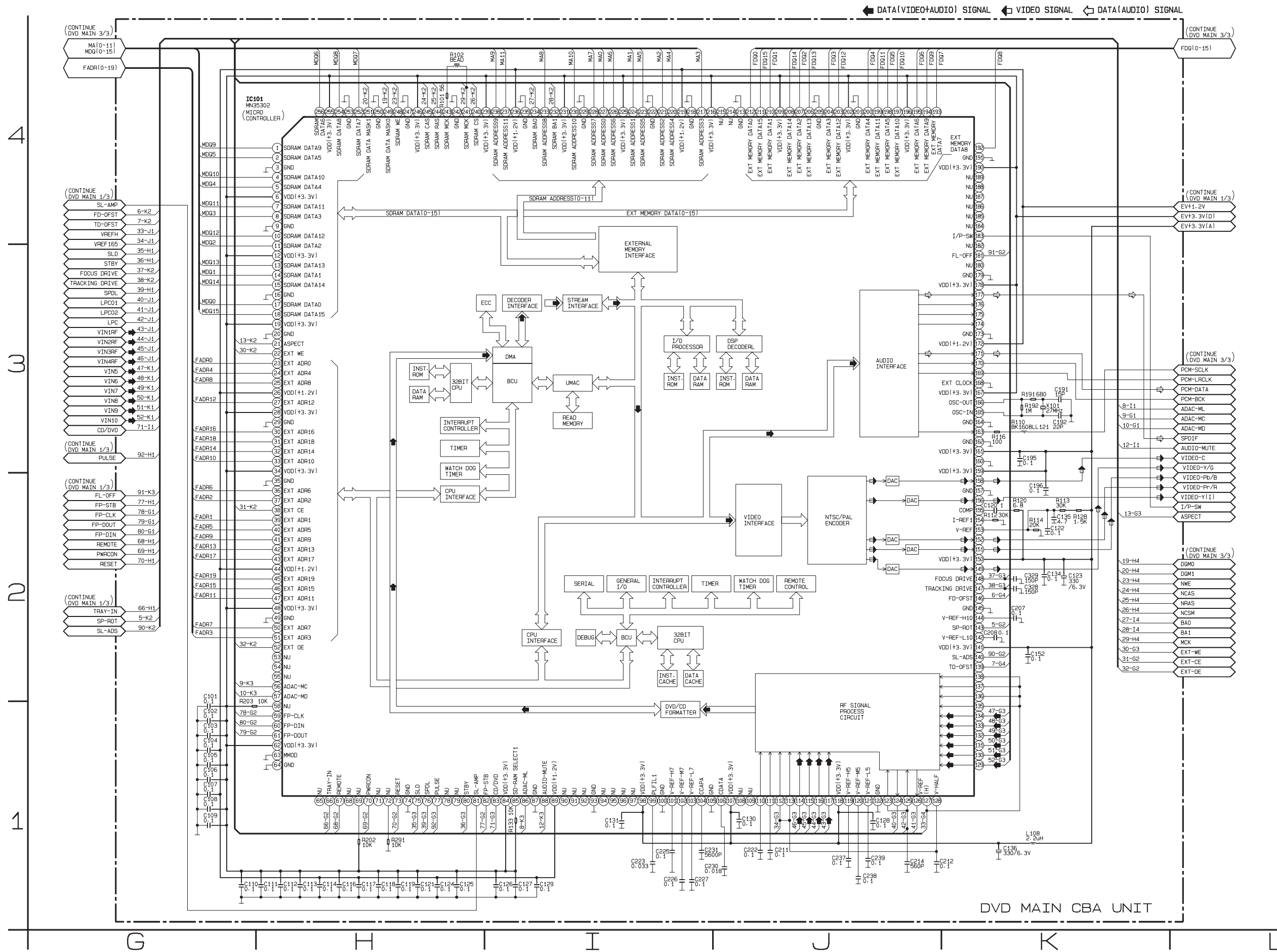

IC101 Voltage Chart

~ : Voltage is not consistent ---- : Not used Unit : Volts

PIN.NO	PLAY	STOP	PIN.NO	PLAY	STOP	PIN.NO	PLAY	STOP	PIN.NO	PLAY	STOP	PIN.NO	PLAY	STOP	PIN.NO	PLAY	STOP	PIN.NO	PLAY	STOP	PIN.NO	PLAY	STOP
1	~	~	33	~	~	65	----	----	97	----	----	129	2.3	2.3	161	3.4	3.4	193	~	~	225	3.4	3.4
2	~	~	34	3.4	3.4	66	3.4	3.5	98	3.4	3.4	130	2.3	2.3	162	0	0	194	~	~	226	~	~
3	0	0	35	0	0	67	3.2	3.2	99	0.9	0.8	131	2.3	2.3	163	1.8	1.8	195	~	~	227	~	~
4	~	~	36	~	~	68	----	----	100	0	0	132	2.4	2.3	164	0	0	196	3.4	3.4	228	~	~
5	~	~	37	~	~	69	3.4	3.4	101	2.4	2.4	133	2.4	2.4	165	1.7	1.8	197	~	~	229	0	0
6	3.4	3.4	38	0.4	0.3	70	3.4	3.4	102	2.2	2.2	134	2.4	2.4	166	1.7	1.7	198	~	~	230	~	~
7	~	~	39	~	~	71	----	----	103	1.9	1.9	135	2.3	2.3	167	3.4	3.4	199	~	~	231	3.4	3.4
8	~	~	40	~	~	72	1.4	2.7	104	0.4	0.3	136	2.3	2.3	168	0	0	200	~	~	232	1.3	1.6
9	0	0	41	~	~	73	3.5	3.5	105	0	0	137	2.3	2.3	169	1.8	1.8	201	0	0	233	~	~
10	~	~	42	~	~	74	0	0	106	1.7	1.7	138	2.3	2.3	170	1.7	1.7	202	3.4	3.4	234	1.9	2.3
11	~	~	43	~	~	75	1.7	1.8	107	3.4	3.4	139	1.7	1.7	171	1.3	0.1	203	~	~	235	0	0
12	3.4	3.4	44	1.3	1.3	76	2.3	1.8	108	----	----	140	1.7	1.7	172	1.3	1.3	204	~	~	236	1.3	1.3
13	~	~	45	~	~	77	2.2	2.2	109	----	----	141	3.4	3.4	173	0	0	205	0	0	237	~	~
14	~	~	46	~	~	78	----	----	110	1.9	1.9	142	1.3	1.3	174	----	----	206	~	~	238	~	~
15	~	~	47	~	~	79	----	----	111	1.9	1.9	143	2.1	1.7	175	----	----	207	~	~	239	3.4	3.4
16	0	0	48	3.4	3.4	80	3.4	0	112	1.7	1.7	144	2.2	2.2	176	----	----	208	~	~	240	3.4	3.3
17	~	~	49	0	0	81	0.1	0.1	113	1.7	1.7	145	0	0	177	1.8	1.7	209	3.4	3.4	241	1.9	1.9
18	~	~	50	~	~	82	2.8	2.8	114	1.7	1.7	146	1.7	1.7	178	3.4	3.5	210	~	~	242	0	0
19	3.4	3.4	51	~	~	83	0.1	0.1	115	1.7	1.7	147	1.8	1.7	179	0	0	211	~	~	243	1.9	1.9
20	0	0	52	0.8	0.8	84	3.4	3.4	116	1.7	1.7	148	1.7	1.7	180	----	----	212	~	~	244	3.4	3.3
21	1.6	1.6	53	----	----	85	0.1	0.1	117	1.7	1.7	149	0.6	0.5	181	0	0	213	0	0	245	3.4	3.4
22	3.4	3.4	54	----	----	86	3.6	3.4	118	3.4	3.4	150	3.4	3.4	182	----	----	214	----	----	246	3.4	3.4
23	~	~	55	----	----	87	0	0	119	2.0	2.0	151	0.5	0.5	183	3.4	3.4	215	----	----	247	0	0
24	~	~	56	3.4	3.4	88	3.5	0.1	120	1.7	1.7	152	0.5	0.5	184	----	----	216	3.4	3.4	248	3.3	3.4
25	~	~	57	3.5	3.5	89	1.3	1.3	121	1.5	1.5	153	1.4	1.3	185	----	----	217	~	~	249	3.2	3.0
26	1.3	1.3	58	3.4	3.4	90	----	----	122	0	0	154	1.4	1.3	186	----	----	218	0	0	250	0	0
27	~	~	59	3.4	3.4	91	----	----	123	0.3	0.1	155	2.4	2.4	187	----	----	219	1.3	1.3	251	3.2	3.0
28	3.4	3.4	60	3.4	3.4	92	----	----	124	1.1	0.1	156	0.6	0.6	188	----	----	220	~	~	252	~	~
29	0	0	61	3.5	3.5	93	0	0	125	0.3	0.1	157	0	0	189	----	----	221	~	~	253	0	0
30	~	~	62	3.4	3.4	94	----	----	126	0.1	0.1	158	0.9	0.9	190	3.4	3.5	222	0	0	254	~	~
31	~	~	63	0	0	95	----	----	127	2.3	2.3	159	3.4	3.4	191	0	0	223	~	~	255	3.4	3.4
32	~	~	64	0	0	96	----	----	128	1.7	1.7	160	0	0	192	~	~	224	~	~	256	~	~

DVD Main 3/3 Schematic Diagram

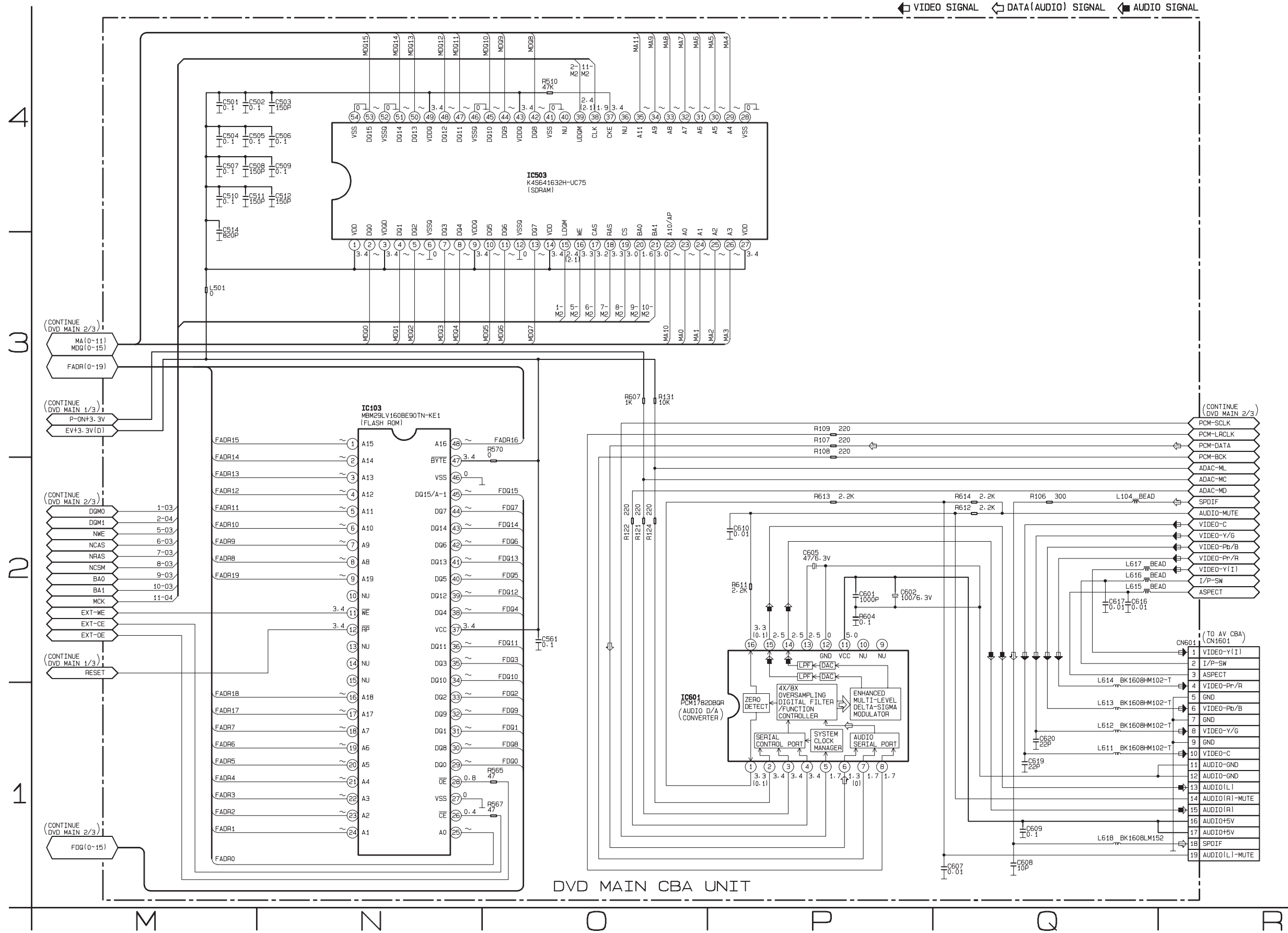

AV 1/3 Schematic Diagram

CAUTION !

Fixed voltage (or Auto voltage selectable) power supply circuit is used in this unit.
If Main Fuse (F1001) is blown, check to see that all components in the power supply circuit are not defective before you connect the AC plug to the AC power supply.
Otherwise it may cause some components in the power supply circuit to fail.

CAUTION !

For continued protection against fire hazard,
replace only with the same type fuse.

NOTE:

The voltage for parts in hot circuit is measured using hot GND as a common terminal.

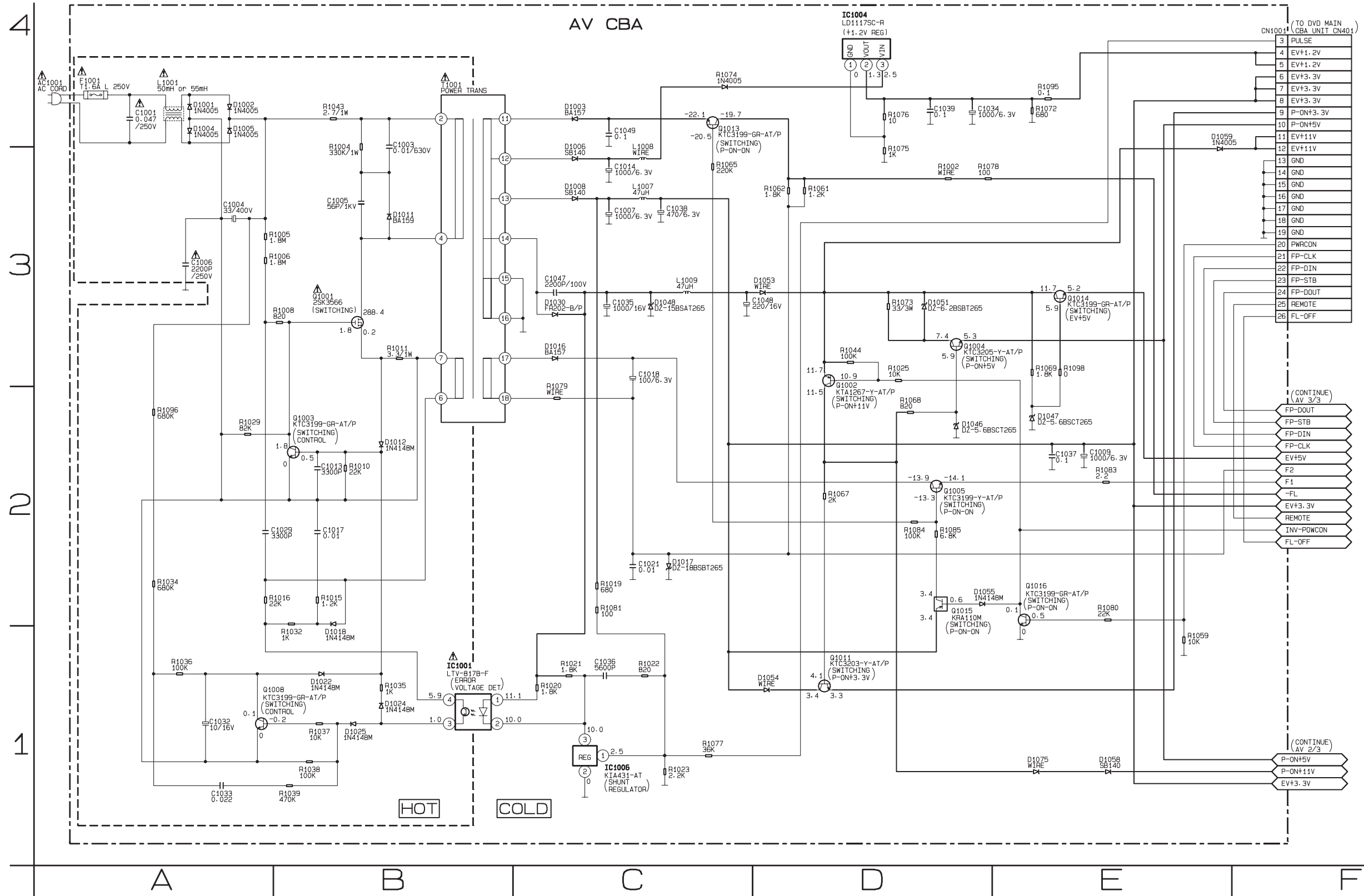

AV 2/3 Schematic Diagram

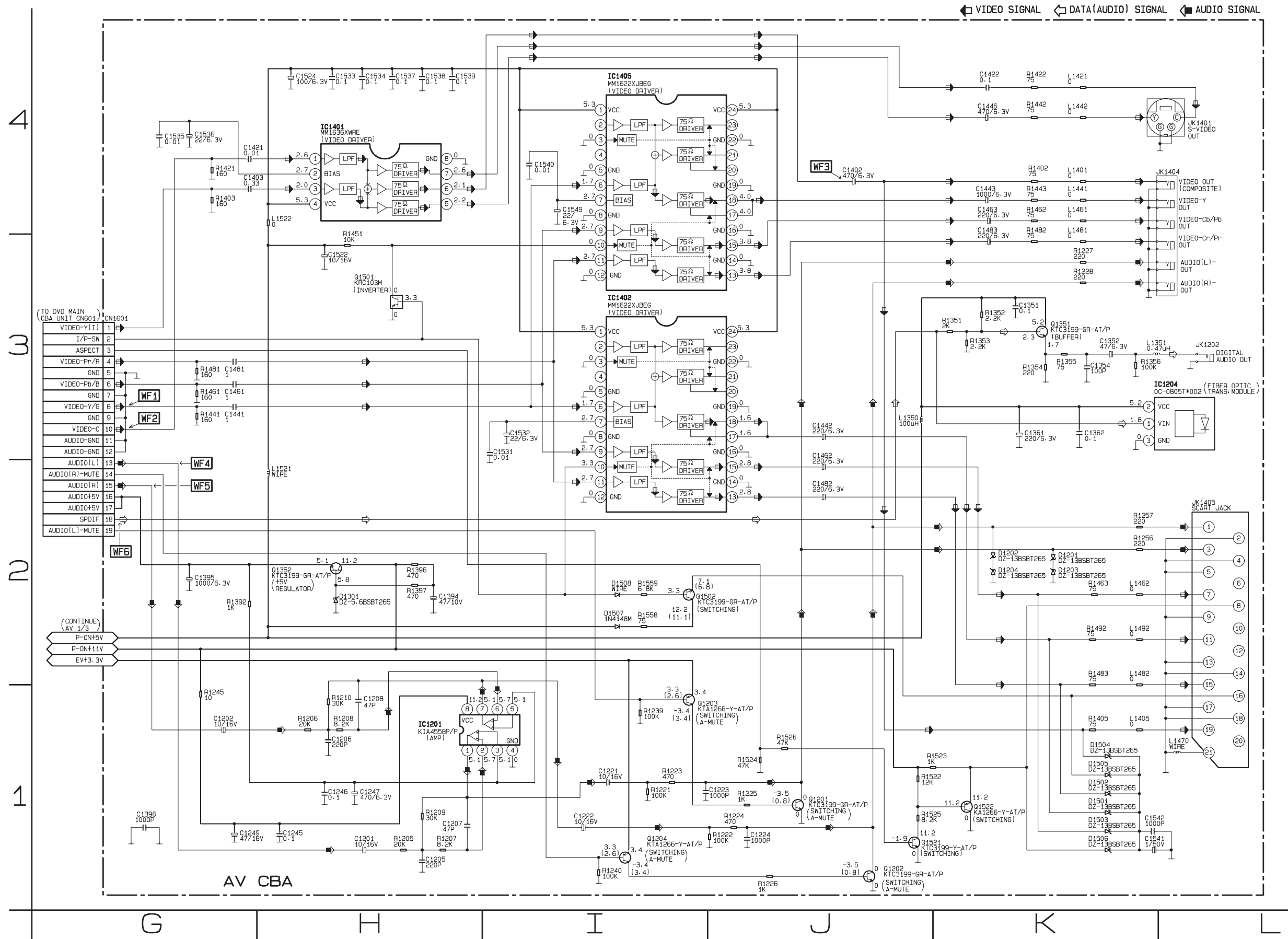

AV 3/3, Function & LED Schematic Diagram

FL2001 MATRIX CHART

	7G	6G	5G	4G	3G	2G	1G
a		a	a	a	a	a	SACD
b	REPEAT	b	b	b	b	b	PSCAN
c	A-	c	c	c	c	c	DVD
d	B	d	d	d	d	d	A
e	ALL	e	e	e	e	e	P
f		f	f	f	f	f	M
g		g	g	g	g	g	HD
h		: GROUP	: CHP.	TRK.	V		
i	i	TITLE VCR	.		REC	CD	

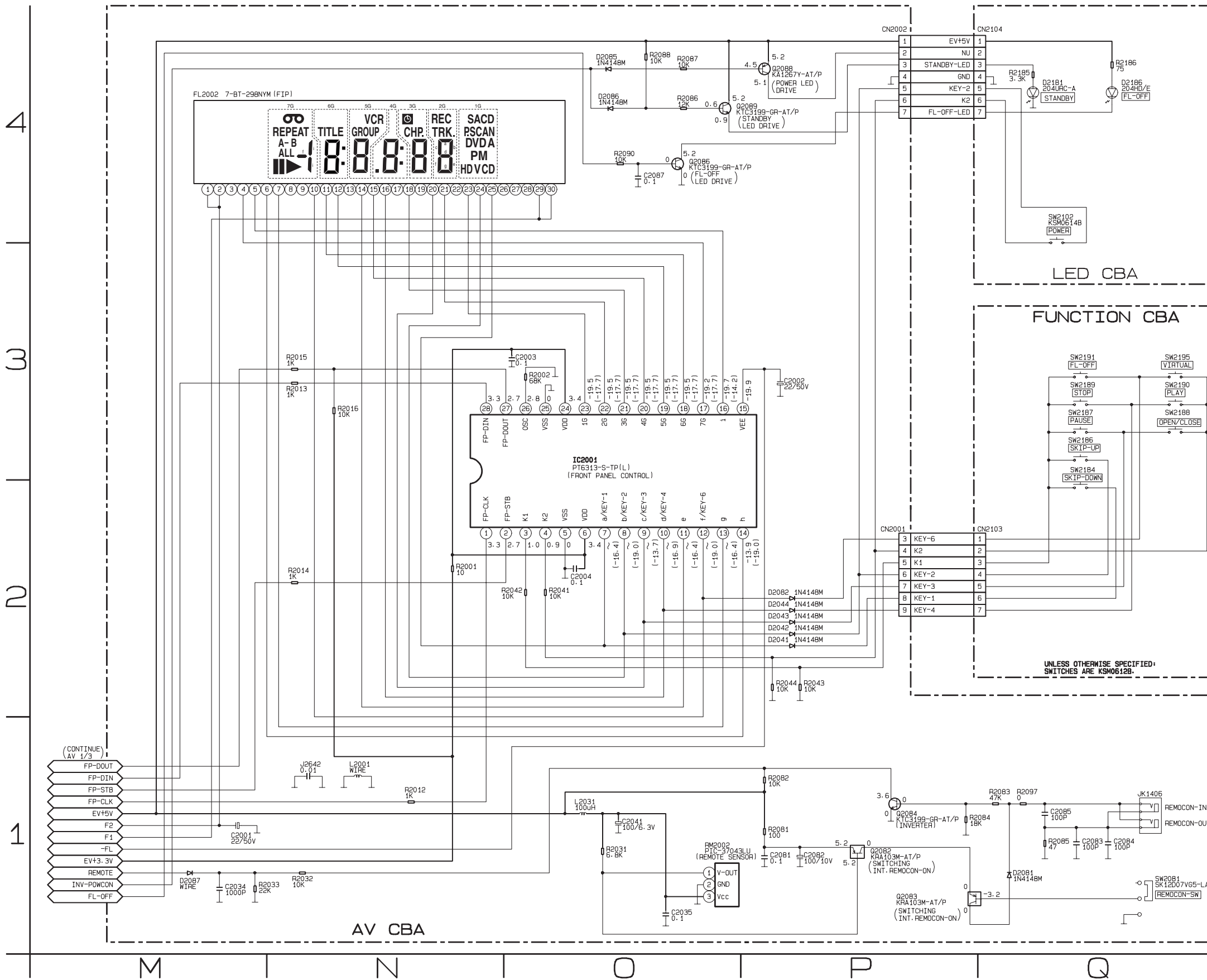

4
3
2
1

M N O P Q

AV CBA Top View

CAUTION !

Fixed voltage (or Auto voltage selectable) power supply circuit is used in this unit.
 If Main Fuse (F1001) is blown , check to see that all components in the power supply circuit are not defective before you connect the AC plug to the AC power supply.
 Otherwise it may cause some components in the power supply circuit to fail.

CAUTION !

For continued protection against fire hazard,
 replace only with the same type fuse.

NOTE:

The voltage for parts in hot circuit is measured using
 hot GND as a common terminal.

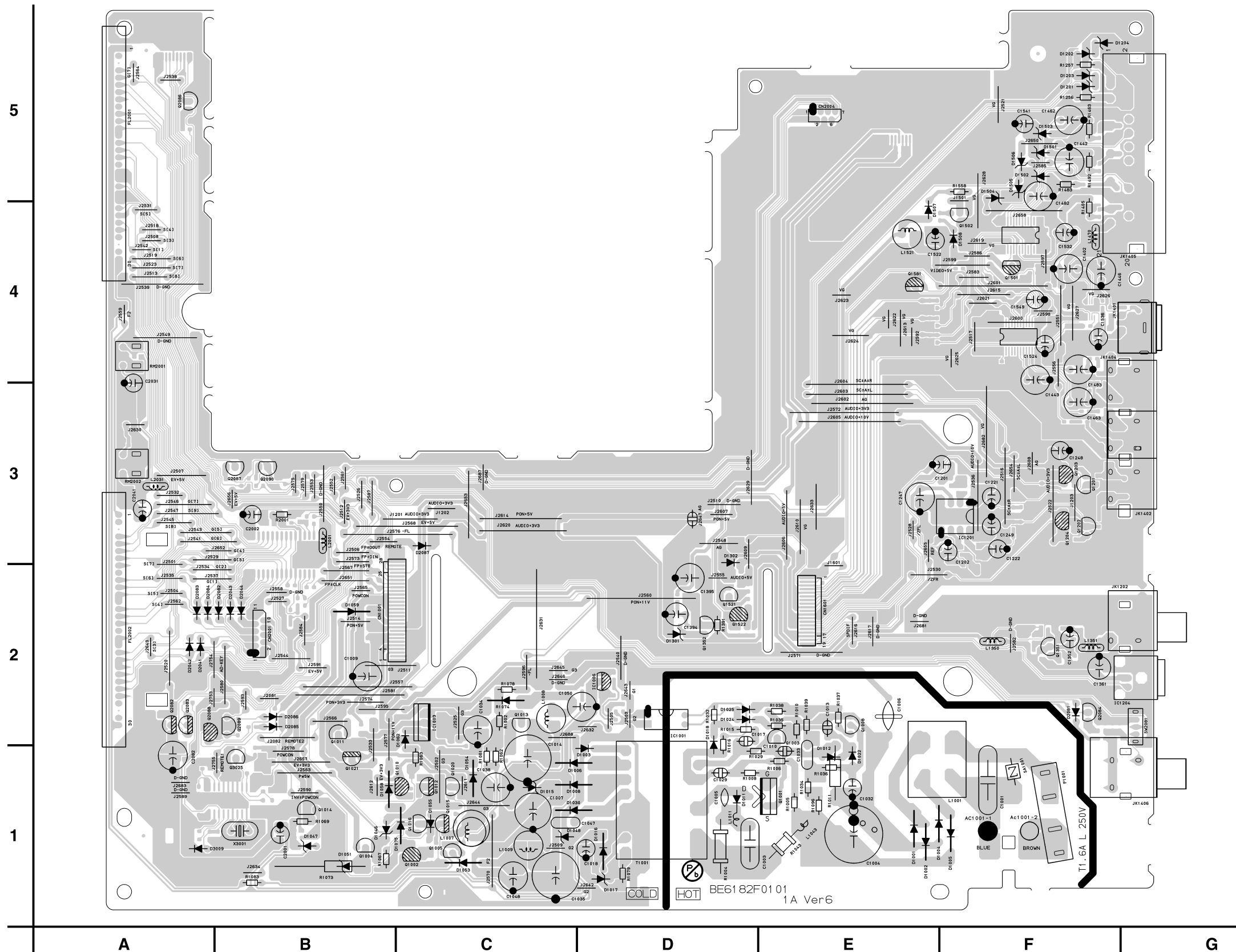

AV CBA Bottom View

CAUTION !

Fixed voltage (or Auto voltage selectable) power supply circuit is used in this unit.
If Main Fuse (F1001) is blown, check to see that all components in the power supply circuit are not defective before you connect the AC plug to the AC power supply.
Otherwise it may cause some components in the power supply circuit to fail.

CAUTION !

For continued protection against fire hazard,
replace only with the same type fuse.

NOTE:

The voltage for parts in hot circuit is measured using
hot GND as a common terminal.

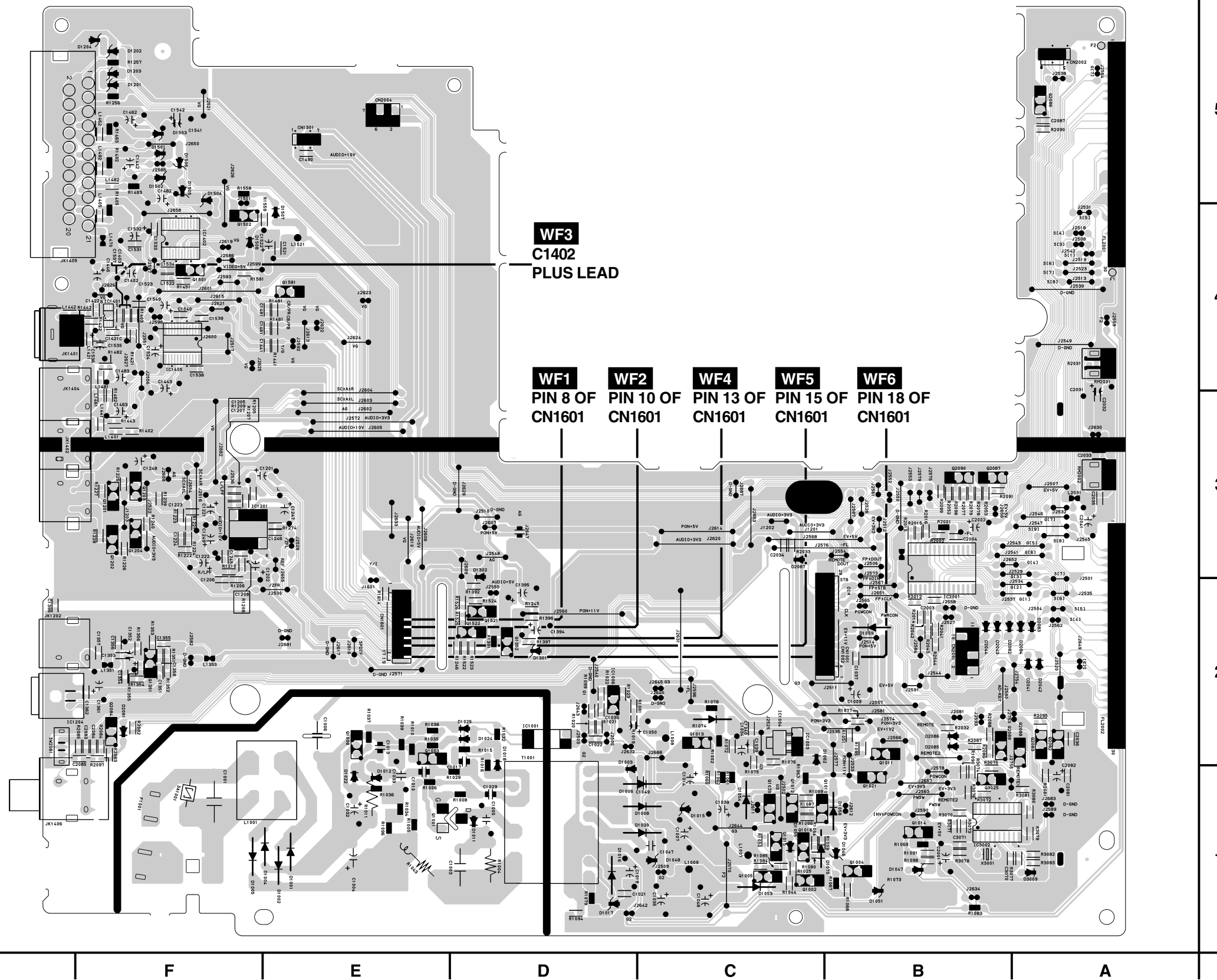

FUNCTION CBA Top View

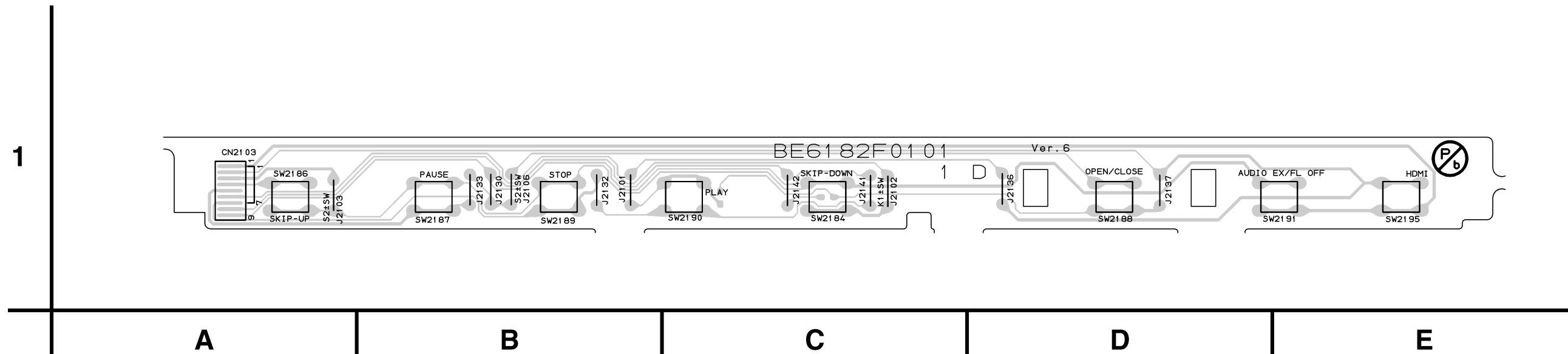

FUNCTION CBA Bottom View

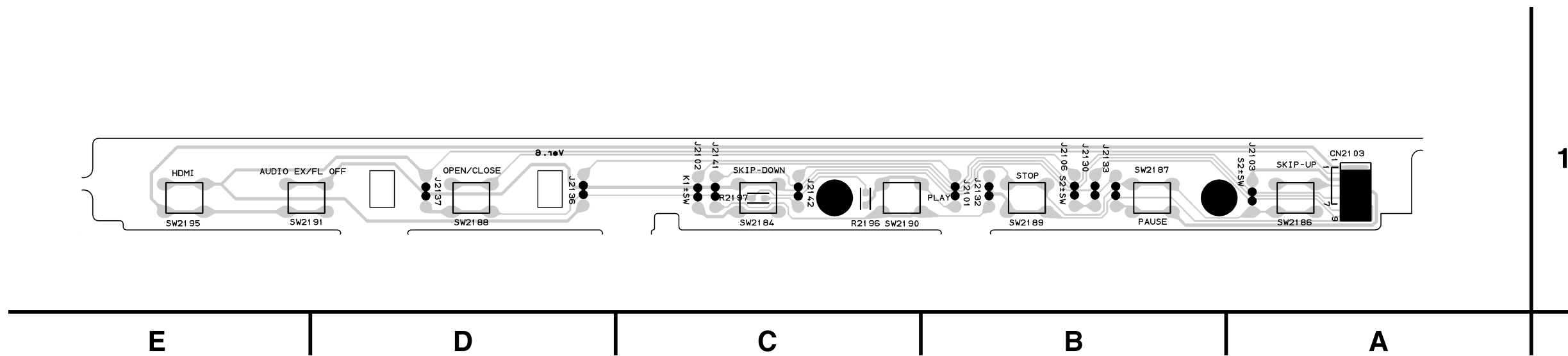

LED CBA Top View

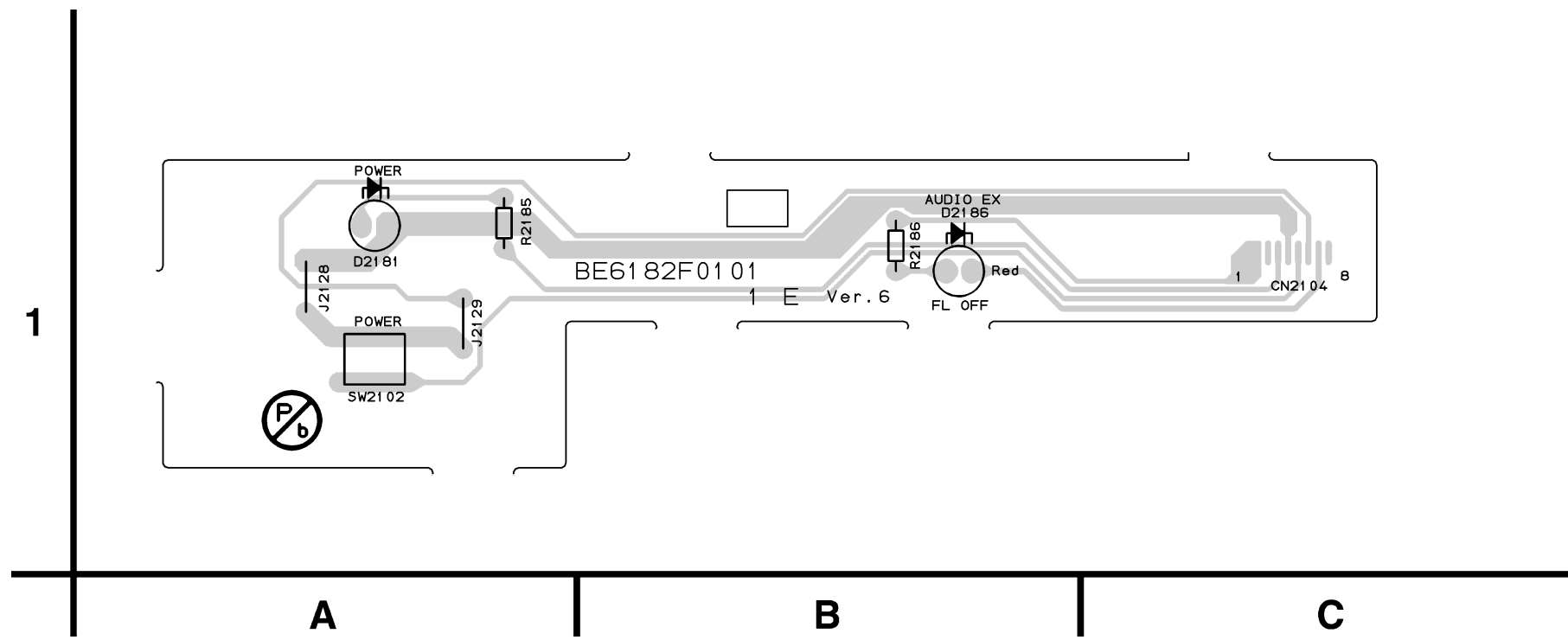

LED CBA Bottom View

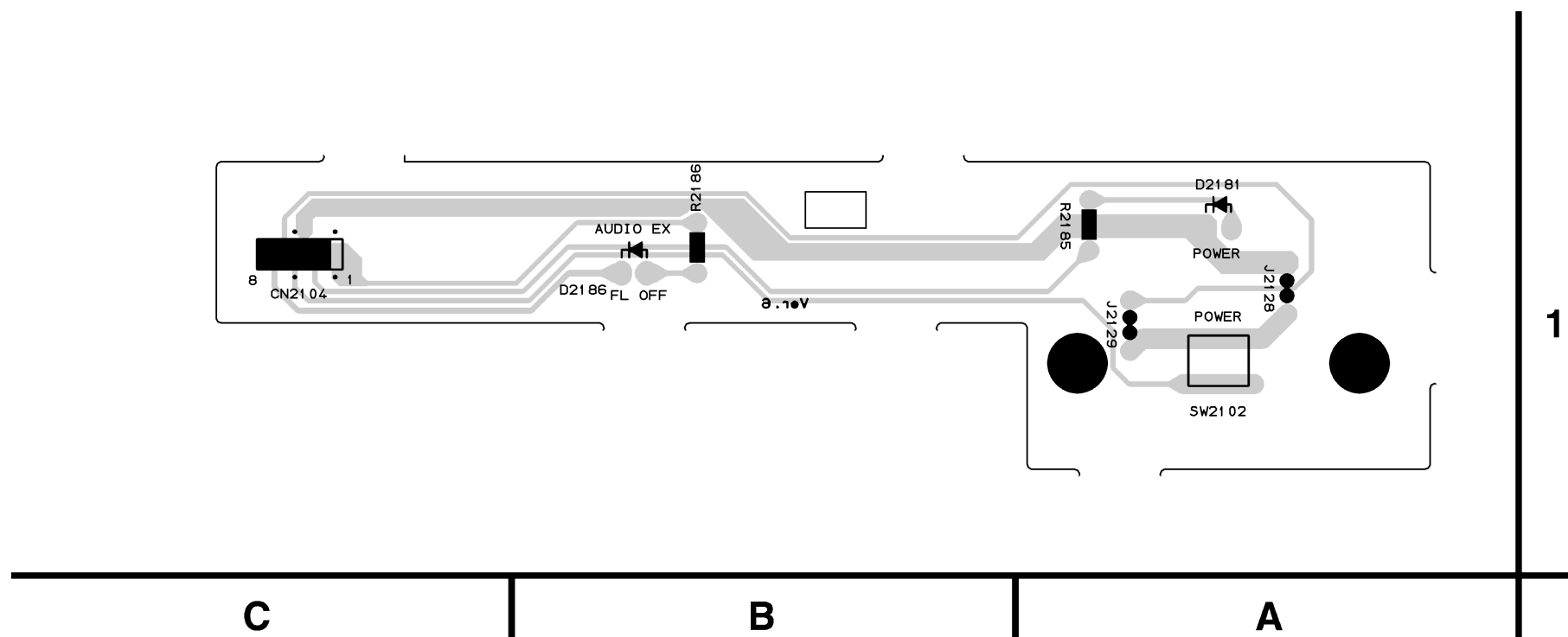

WAVEFORMS

WF1 Pin 8 of CN1601

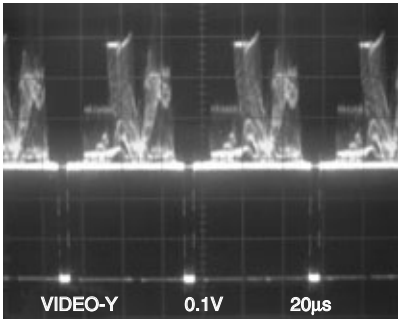

WF5 Pin 15 of CN1601

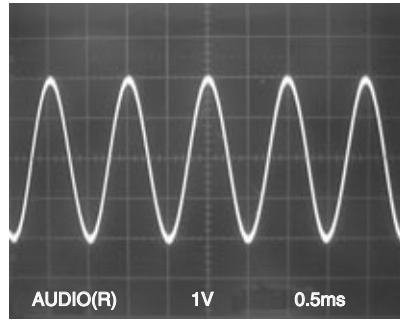

WF2 Pin 10 of CN1601

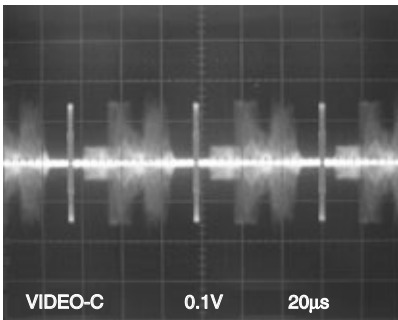

WF6 Pin 18 of CN1601

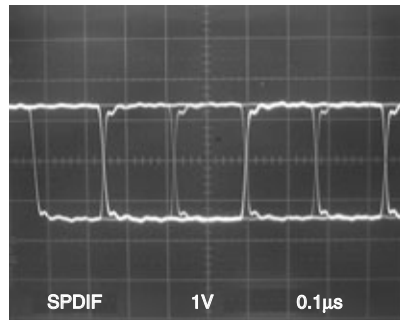

WF3 C1402 PLUS LEAD

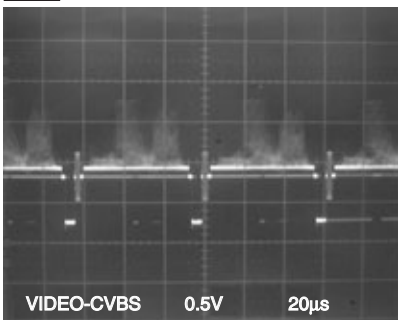

NOTE:

Input

CD: 1kHz PLAY
(WF4~WF6)

DVD: POWER ON (STOP) MODE
(WF1~WF3)

WF4 Pin 13 of CN1601

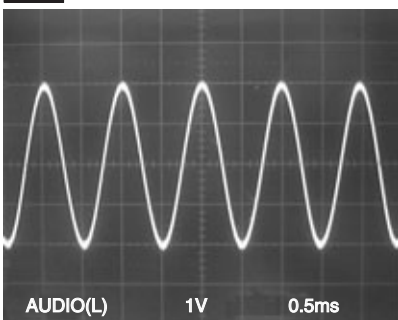

WIRING DIAGRAM

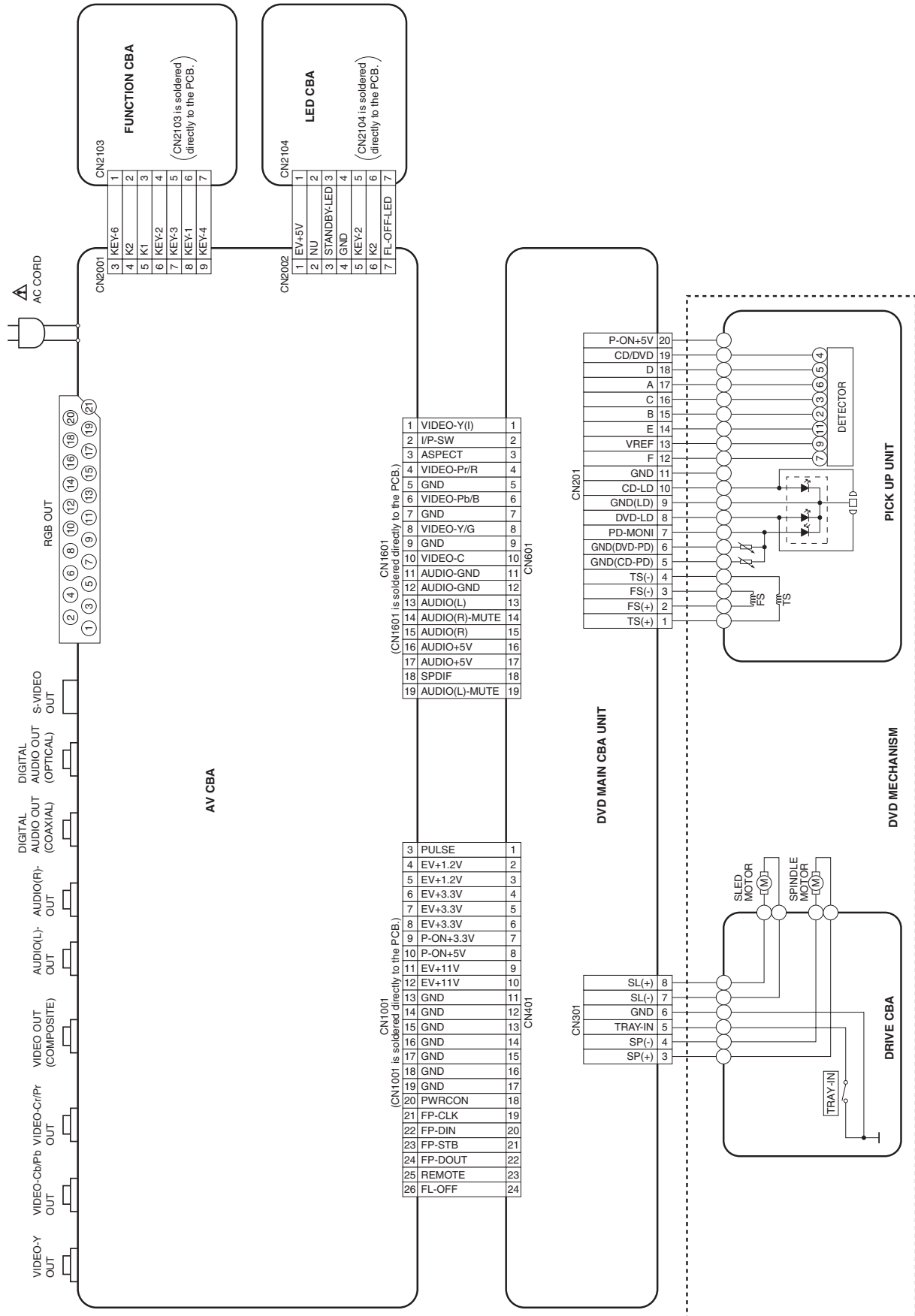

IC PIN FUNCTION DESCRIPTIONS

IC2001 [PT6313-S-TP(L)]

Pin No.	In/Out	Signal Name	Name Function
1	In	FP-CLK	Clock Input
2	In	FP-STB	Serial Interface Strobe
3	In	K1	Key Data 1 Input
4	In	K2	Key Data 2 Input
5	-	VSS	GND
6	-	VDD	Power Supply
7	Out	a / KEY-1	Segment Output / Key Source-1
8	Out	b / KEY-2	Segment Output / Key Source-2
9	Out	c / KEY-3	Segment Output / Key Source-3
10	Out	d / KEY-4	Segment Output/ Key Source-4
11	Out	e	Segment Output
12	In	f / KEY-6	Segment Output/ Key Source-6
13	In	g	Segment Output
14	Out	h	Segment Output
15	-	VEE	Pull Down Level
16	Out	i	Segment Output
17	Out	7G	Grid Output
18		6G	
19		5G	
20		4G	
21		3G	
22		2G	
23		1G	
24	-	VDD	Power Supply
25	-	VSS	GND
26	In	OSC	Oscillator Input
27	Out	FP-DOUT	Serial Data Output
28	IN	FP-DIN	Serial Data Input

LEAD IDENTIFICATIONS

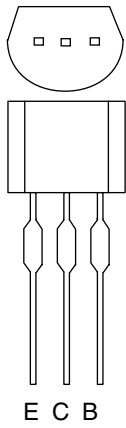

2SA1015-Y(T E2 F T)
 2SA1015-Y(TPE2)
 2SC2120-Y(T E2 F T)
 2SC2120-Y(TPE2)
 2SC2236-Y-TPE6 C
 BA1F4M-T
 KRC103M
 KTA1266(Y)
 KTA1266-Y-AT/P
 KTC3203(Y)
 KTC3203-Y-AT/P
 KTC3205(Y)
 KTC3205-Y-AT/P

E C B

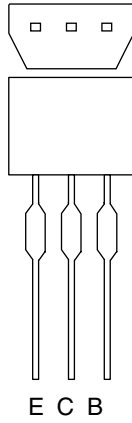

2SC1815-GR(T E2 F T)
 2SC1815-GR(TPE2)
 2SC1815-Y(T E2 F T)
 2SC1815-Y(TPE2)
 BN1L3Z(P)
 KRA110M
 KTA1267(Y)
 KTA1267Y-AT/P
 KTC3199(GR,Y)
 KTC3199-GR-AT/P
 KTC3199-Y-AT/P

E C B

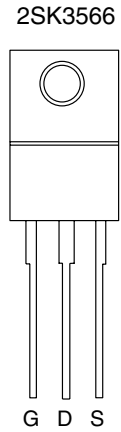

G D S

KIA4558P/P
 RC4580IP
 UTC4558
 MM1636XWRE

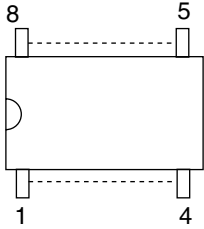

1 4 5 8

PT6313-S-TP(L)
 SC16313G

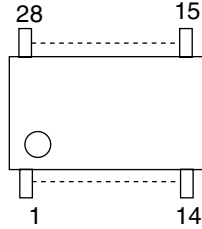

1 14 15 28

FAN431AZXA
 KIA431-AT

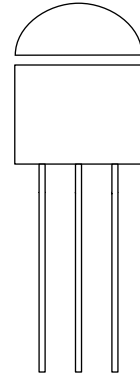

1: R
 2: A
 3: K

K A R

EL817B
 EL817C
 LTV-817B-F
 LTV-817C-F
 PS2561A-1(W)

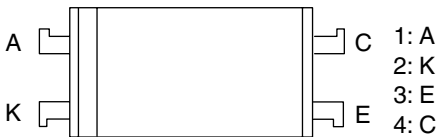

1: A
 2: K
 3: E
 4: C

MM1622XJBEG

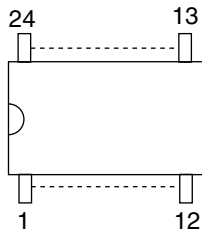

1 12 13 24

LD1117SC-R

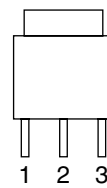

1 2 3

1: GND
 2: Vout
 3: Vin

0C-0805T*002

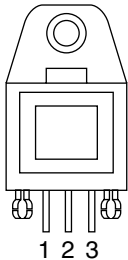

1 2 3

Note:

- A: Anode
- K: Cathode
- E: Emitter
- C: Collector
- B: Base
- R: Reference
- G: Gate
- D: Drain
- S: Source

EXPLODED VIEWS

Cabinet

See Electrical Parts List for parts with this mark.
Some Ref. Numbers are not in sequence.

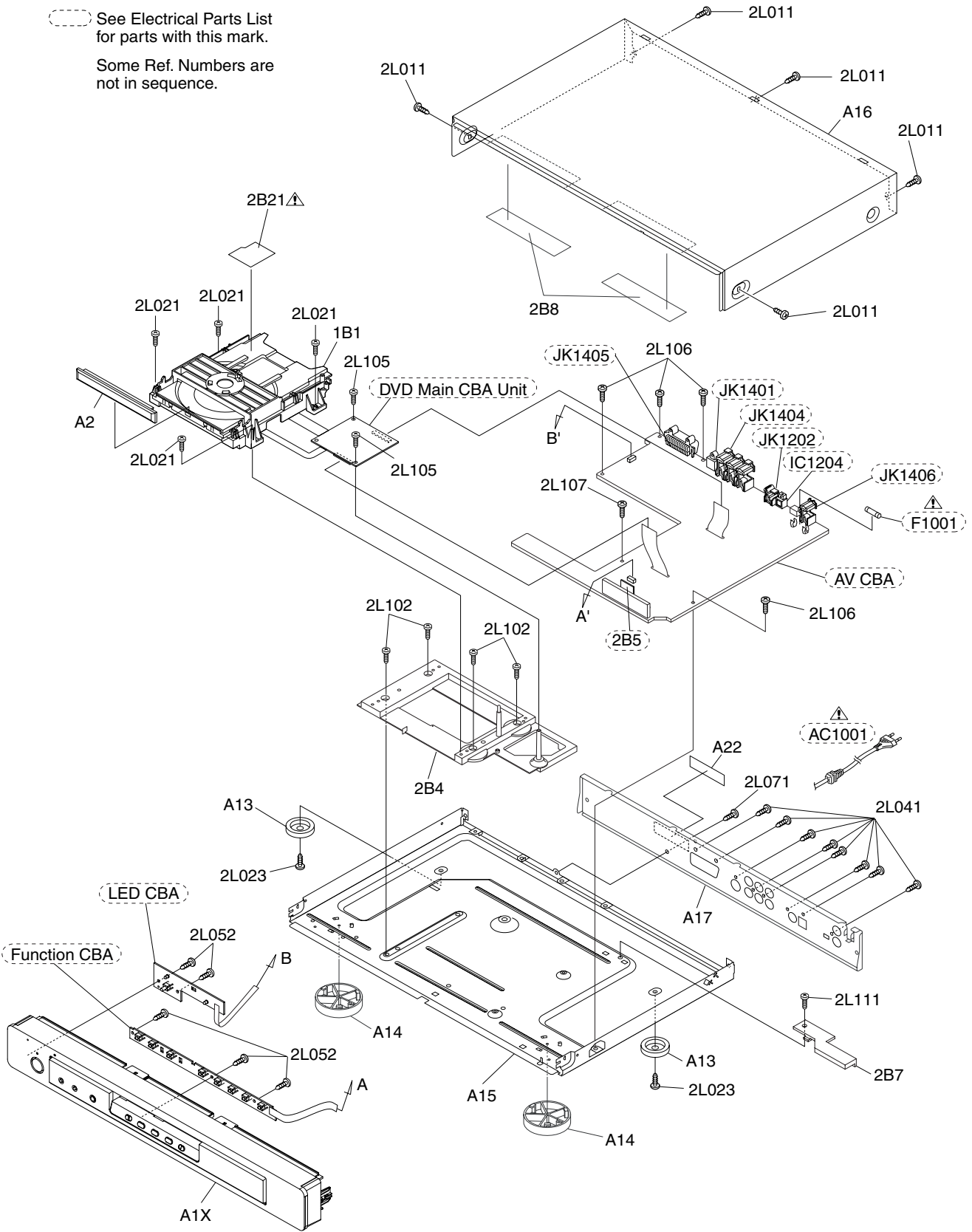

Packing

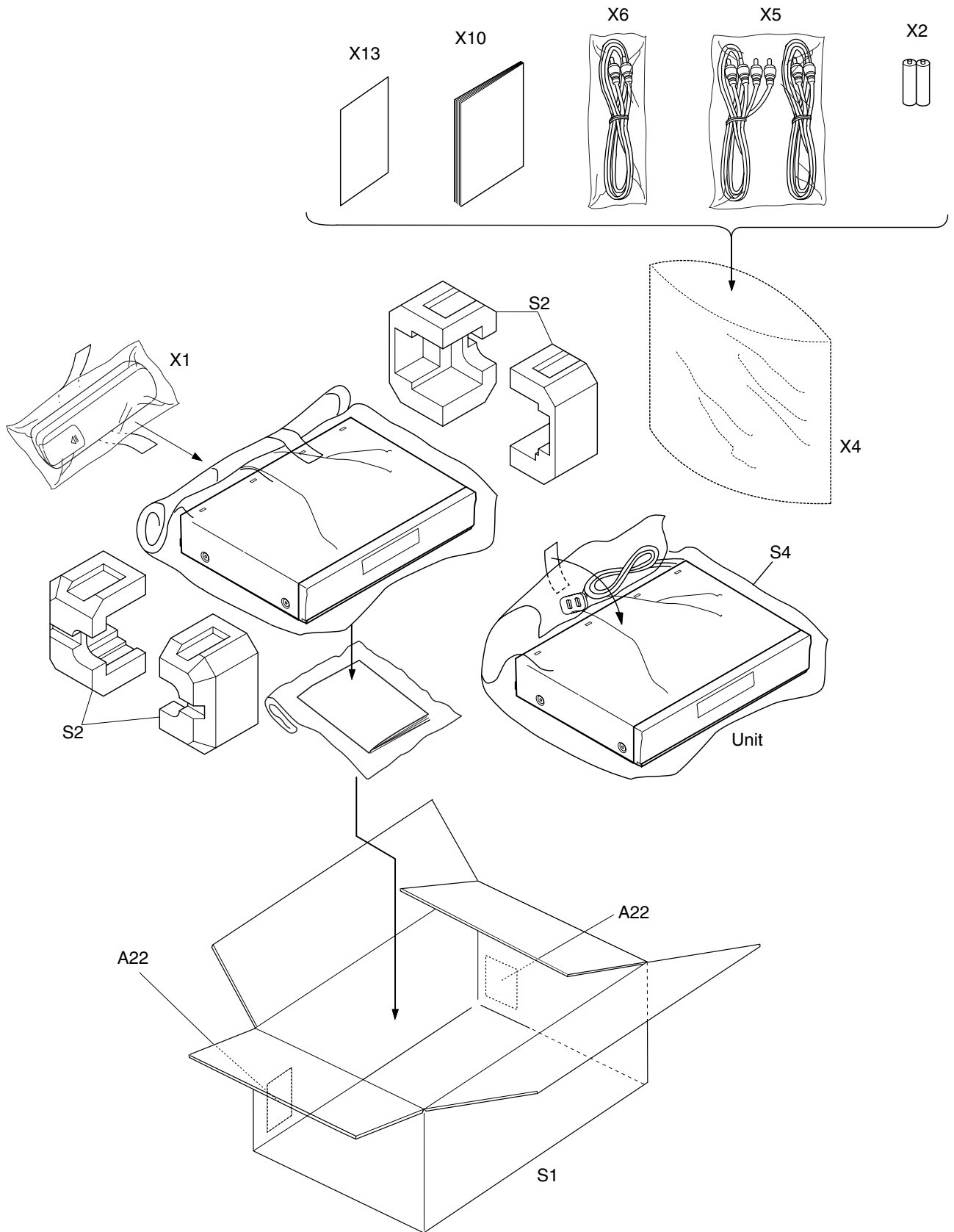

PARTS LIST

POS. NO.	VERS. COLOR	PART NO. (FOR EUR)	PART NO. (MZ)	PART NAME	DESCRIPTION
EXPLODED VIEW PARTS LIST					
A1X	/N1B	00M39BW248510	00M39BW248510	PANEL	FRONT PANEL ASSY DV4600 BLACK E61M0UD 1VM220738
A1X	/N1S	00M39BW248530	00M39BW248530	PANEL	FRONT PANEL ASSY DV4600 SILVER E61M1UD 1VM220739
A2	/N1B	00M39BW063010	00M39BW063010	ESCUTCHEON	TRAY PANEL BLACK E61M0UD 1VM220478
A2	/N1S	00M39BW063210	00M39BW063210	ESCUTCHEON	TRAY PANEL SILVER E61M4ED 1VM421988
A13	/N1B	00M38BW057020	00M38BW057020	LEG	LEG ASSY (REAR) BLACK GOLD E61M0UD 1VM421930
A13	/N1S	00M38BW057220	00M38BW057220	LEG	LEG ASSY (REAR) SILVER E61M4ED 1VM421931
A14	/N1B	00M38BW057010	00M38BW057010	LEG	LEG ASSY (FRONT) BLACK GOLD E61M0UD 1VM421932
A14	/N1S	00M38BW057210	00M38BW057210	LEG	LEG ASSY (FRONT) SILVER 1VM421933
A15		nsp	nsp	CHASSIS	MAIN CHASSIS DV4600 E6180UD 1VM120073
A17		nsp	nsp	PANEL	REAR PANEL DV4600 FOR N 1VM220496
1B1		00M39BW304010	00M39BW304010	MECHANISM	MECHA LOADER AND TRAVERSE DVD MECHA E6160(FG LESS) N79F0JVM
		90M-ZZ002910R	90M-ZZ002910R	PWB ASSY	DVD MAIN CBA UNIT N79B0JEP
		90M-ZZ002920R	90M-ZZ002920R	PWB ASSY	AV CBA ASSY / FUNCTION CBA ASSY / LED CBA ASSY 1VSA11910
PACKING					
▲ AC1001		90M-YC000820R	90M-YC000820R	MAINS CORD	! MAINS CORD PE8B2CG980A-057 WAE0172LW006
X1		00M39BW0010	00M39BW0010	UNIT KIT	REMOTE CONTROLLER RC6600DV NA836ED NA836ED
X10		00M39BW851310	00M39BW851310	USER GUIDE	USER GUIDE DV4600/N E61M4ED 1VMN20829
NOT STANDARD SPARE PART					
A16	/N1B	nsp	00M38BW257010	LID	TOP COVER BLACK E61M0UD 1VM320704
A16	/N1S	nsp	00M38BW257210	LID	TOP COVER SILVER E61M4ED 1VM320706
S1		nsp	00M39BW801010	PACKING CASE	PACKING CASE DV4600 E61M0UD 1VM321090
S2		nsp	00M38BW809010	CUSHION	CUSHION DV4600 E61M0UD 1VM120092
X5		nsp	90M-ZD000470R	CORD	AV CORD TSCKA-Y/RW100 WPZ0102TM015
X5		nsp	90M-ZD000480R	CORD	AV CORD RCA(M*2)TO RCA(M*2) WPZ0102LTE01
X5		nsp	90M-ZD000490R	CORD	AV CORD DC2FN020001 WPZ0102CAB01
X6		nsp	90M-ZD000500R	CORD	AV CORD WPZ0102TM017 WPZ0102TM017
ELECTRICAL PARTS LIST					
AV CBA					
▲ C1001		90M-DF100360R	90M-DF100360R	FILM CAP.	! METALLIZED FILM CAP. 0.047UF/250V K OR M CT2E473DC011 OR CT2E473MS037
▲ C1006		90M-DK100850R	90M-DK100850R	CER. CAP.	! SAFETY CAP. 2200PF/250V CA2E222MR049 OR CCN2EMP0E222
CN1001		nsp	90M-YU002010R	FPC	24P FFC AV PCB TO MAIN WX1E59E0-001
CN1601		nsp	90M-YU002020R	FPC	FFC CABLE 19P 19PIN/110MM WX1E6182-001
CN2104		nsp	90M-YU002030R	FPC	FFC CABLE 7P AV PCB TO IND PCB WX1E61M2-003
IC1204		90M-YJ002710R	90M-YJ002710R	OPT. CONN.	FIBER OPTIC TRANS. MODULE 0C-0805T*002 JWVHA00JD002
▲ L1001		90M-FN000190R	90M-FN000190R	FILTER	! LINE FILTER 56MH TLF14CB5630R2 LLBG00ZTU022 OR LLBG00ZKQ014
SW2081		90M-SS000760R	90M-SS000760R	SW	SLIDE SWITCH SK12D07VG5-L A SSS0102LY003
▲ F1001		90M-FS001120R	90M-FS001120R	FUSE	! FUSE T1.6AL/250V PAGC20BW3162
JK1202		90M-YT003370R	90M-YT003370R	TERMINAL	CINCH JACK(BLACK) MSP-251V-01 NI FE LF JXRL010LY125 OR JXRL010LY070
JK1401		90M-YT003380R	90M-YT003380R	TERMINAL	S TYPE JACK MDC-050V-2.4 JXEL040LY001
JK1404		90M-YT003850R	90M-YT003850R	TERMINAL	CINCH JACK MSD-246V-65 NI FE LF JXRL060LY131 OR MSD-246V-65NI/PBSN OR JXRL060LY069 OR MSP-246V/34-65NI-FELF OR JXRL060LY082
JK1405		90M-YT003390R	90M-YT003390R	TERMINAL	21P RGB JACK AJ-2050*040 JXGL210JD002
JK1406		90M-YT003860R	90M-YT003860R	TERMINAL	2PIN JACK(ORANGE) MSD-242V-24 JXRL020LY105
▲ T1001		90M-TS002500R	90M-TS002500R	TRANSF.	! SWITCHING TRANS 5702 LTT00EPTK167
FUNCTION CBA					
CN2103		nsp	90M-YU002040R	FPC	FFC CABLE 7P AV PCB TO FNT PCB WX1E61M2-001

NOTE : "nsp" PART IS LISTED FOR REFERENCE ONLY, MARANTZ WILL NOT SUPPLY THESE PARTS.

NOTE ON SAFETY :

Symbol ▲ Fire or electrical shock hazard. Only original parts should be used to replaced any part marked with symbol ▲. Any other component substitution (other than original type), may increase risk of fire or electrical shock hazard.