

Service Manual

DV6400 /N1B/N1S

Super Audio CD / DVD Player

DV4400 /N1B/N1S

DVD Player

DV6400



DV4400

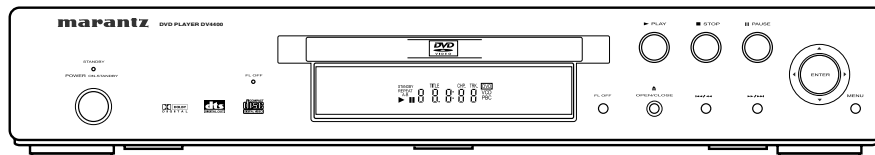

SUPER AUDIO CD



TABLE OF CONTENTS

SECTION	PAGE
TECHNICAL SPECIFICATIONS	1-1-1
SERVICE HINTS AND TOOLS	1-2-1
WARNING AND LASER SAFETY INSTRUCTIONS	1-2-2
LASER BEAM SAFETY PRECAUTIONS	1-2-3
IMPORTANT SAFETY PRECAUTIONS	1-3-1
STANDARD NOTES FOR SERVICING	1-4-1
CABINET DISASSEMBLY INSTRUCTIONS	1-5-1
TROUBLESHOOTING	1-6-1
BLOCK DIAGRAMS	1-7-1
SCHEMATIC DIAGRAMS / CBA'S AND TEST POINTS	1-8-1
WAVEFORMS	1-9-1
WIRING DIAGRAMS	1-10-1
FIRMWARE RENEWAL MODE	1-11-1
LEAD IDENTIFICATIONS	1-12-1
EXPLODED VIEWS	1-13-1
PARTS LIST [DV4400]	1-14-1
PARTS LIST [DV6400]	1-15-1

Please use this service manual with referring to the user guide (D.F.U.) without fail.
 修理の際は、必ず取扱説明書を準備し操作方法を確認の上作業を行ってください。

marantz®

DV4400 / DV6400

MARANTZ DESIGN AND SERVICE

Using superior design and selected high grade components, **MARANTZ** company has created the ultimate in stereo sound. Only original **MARANTZ** parts can insure that your **MARANTZ** product will continue to perform to the specifications for which it is famous.

Parts for your **MARANTZ** equipment are generally available to our National Marantz Subsidiary or Agent.

ORDERING PARTS :

Parts can be ordered either by mail or by Fax.. In both cases, the correct part number has to be specified.

The following information must be supplied to eliminate delays in processing your order :

1. Complete address
2. Complete part numbers and quantities required
3. Description of parts
4. Model number for which part is required
5. Way of shipment
6. Signature : any order form or Fax. must be signed, otherwise such part order will be considered as null and void.

USA

MARANTZ AMERICA, INC
1100 MAPLEWOOD DRIVE
ITASCA, IL. 60143
USA
PHONE : 630 - 741 - 0300
FAX : 630 - 741 - 0301

EUROPE / TRADING

MARANTZ EUROPE B.V.
P. O. BOX 8744, BUILDING SILVERPOINT
BEEMDSTRAAT 11, 5653 MA EINDHOVEN
THE NETHERLANDS
PHONE : +31 - 40 - 2507844
FAX : +31 - 40 - 2507860

CANADA

LENBROOK INDUSTRIES LIMITED
633 GRANITE COURT,
PICKERING, ONTARIO L1W 3K1
CANADA
PHONE : 905 - 831 - 6333
FAX : 905 - 831 - 6936

PROFESSIONAL AMERICAS

SUPERSCOPE TECHNOLOGIES, INC.
MARANTZ PROFESSIONAL PRODUCTS
2640 WHITE OAK CIRCLE, SUITE A
AURORA, ILLINOIS 60504 USA
PHONE : 630 - 820 - 4800
FAX : 630 - 820 - 8103

PROFESSIONAL AUSTRALIA

TECHNICAL AUDIO GROUP PTY, LTD
43-53 Bridge Rd.,
STANMORE NSW 2048
AUSTRALIA
PHONE : +61 - (0)2 - 9519 - 0900
FAX : +61 - (0)2 - 9519 - 0600

PROFESSIONAL HONG KONG

Jolly ProAudio Broadcast Engineering Ltd.
UNIT 2, 10F, WAH HUNG CENTRE,
41 HUNG TO ROAD, KWUN TONG, KLN.,
HONG KONG
PHONE : 852 - 21913660
FAX : 852 - 21913990

AUSTRALIA

QualiFi Pty Ltd,
24 LIONEL ROAD,
MT. WAVERLEY VIC 3149
AUSTRALIA
PHONE : +61 - (0)3 - 9543 - 1522
FAX : +61 - (0)3 - 9543 - 3677

THAILAND

MRZ STANDARD CO., LTD
746 - 754 MAHACHAI ROAD.,
WANGBURAPAPIROM, PHRANAKORN,
BANGKOK, 10200 THAILAND
PHONE : +66 - 2 - 222 9181
FAX : +66 - 2 - 224 6795

SINGAPORE

WO KEE HONG DISTRIBUTION PTE LTD
130 JOO SENG ROAD
#03-02 OLIVINE BUILDING
SINGAPORE 368357
PHONE : +65 6858 5535 / +65 6381 8621
FAX : +65 6858 6078

NEW ZEALAND

WILDASH AUDIO SYSTEMS NZ
14 MALVERN ROAD MT ALBERT
AUCKLAND NEW ZEALAND
PHONE : +64 - 9 - 8451958
FAX : +64 - 9 - 8463554

TAIWAN

PAI- YUING CO., LTD.
6 TH FL NO, 148 SUNG KIANG ROAD,
TAIPEI, 10429, TAIWAN R.O.C.
PHONE : +886 - 2 - 25221304
FAX : +886 - 2 - 25630415

MALAYSIA

WO KEE HONG ELECTRONICS SDN. BHD.
2ND FLOOR BANGUNAN INFINITE CENTRE
LOT 1, JALAN 13/6, 46200 PETALING JAYA
SELANGOR DARUL EHSAN, MALAYSIA
PHONE : +60 - 3 - 7954 8088
FAX : +60 - 3 - 7954 7088

JAPAN *Technical*

MARANTZ JAPAN, INC.
35- 1, 7- CHOME, SAGAMIONO
SAGAMIHARA - SHI, KANAGAWA
JAPAN 228-8505
PHONE : +81 42 748 1013
FAX : +81 42 741 9190

日本マランツ株式会社

本社 〒228-8505
神奈川県相模原市相模大野7-35-1

KOREA

MK ENTERPRISES LTD.
ROOM 604/605, ELECTRO-OFFICETEL, 16-58,
3GA, HANGANG-RO, YONGSAN-KU, SEOUL
KOREA
PHONE : +822 - 3232 - 155
FAX : +822 - 3232 - 154

SHOCK, FIRE HAZARD SERVICE TEST :

CAUTION : After servicing this appliance and prior to returning to customer, measure the resistance between either primary AC cord connector pins (with unit NOT connected to AC mains and its Power switch ON), and the face or Front Panel of product and controls and chassis bottom.

Any resistance measurement less than 1 Megohms should cause unit to be repaired or corrected before AC power is applied, and verified before it is return to the user/customer.

Ref. UL Standard No. 1492.

In case of difficulties, do not hesitate to contact the Technical Department at above mentioned address.

TECHNICAL SPECIFICATIONS

[DV4400]

SIGNAL SYSTEM

PAL color

APPLICABLE DISCS

- (1) DVD-Video Discs
 - 1-layer 12cm single-sided discs, 2-layer 12cm single-sided discs, 2-layer 12cm double-sided discs (1 layer per side)
 - 1-layer 8cm single-sided discs, 2-layer 8cm single-sided discs, 2-layer 8cm double-sided discs (1 layer per side)
- (2) DVD-R/DVD-RW
- (3) Compact discs (CD-DA)
 - 12cm discs, 8cm discs
- (4) CD-R/CD-RW

S-VIDEO OUTPUT

Y output level: 1Vp-p (75Ω/ohms)
 C output level: 0.30Vp-p
 Output connectors: S connectors, 1 set

VIDEO OUTPUT

Output level: 1Vp-p (75Ω/ohms)
 Output connector: Pin jacks, 1 set

COMPONENT OUTPUT

Y output level: 1Vp-p (75Ω/ohms)
 C_B output level: 0.7Vp-p (75Ω/ohms)
 C_R output level: 0.7Vp-p (75Ω/ohms)
 Output connector: Pin jacks, 1 set

AUDIO/VIDEO

21-pin scart jack

AUDIO OUTPUT

Output level: 2Vrms
 2 channel (L, R) output connector: Pin jack, 1 set

AUDIO OUTPUT PROPERTIES

- (1) Frequency response
 - 1 DVDs (linear PCM) : 4Hz to 22kHz (48 kHz sampling)
 - : 4Hz to 44kHz (96 kHz sampling)
 - 2 CDs : 4Hz to 20kHz
- (2) S/N ratio : 115dB
- (3) Total harmonic distortion : 1kHz CD: 0.003%
- (4) Dynamic range : DVD: 100dB
 CD: 98dB

DIGITAL AUDIO OUTPUT

Optical digital output: Optical connector, 1 set
 Coaxial digital output: Pin jack, 1 set

POWER SUPPLY

AC 230V, 50Hz

POWER CONSUMPTION

15W (Standby: 1.0W)

MAXIMUM EXTERNAL DIMENSIONS

440 (width) x 75 (height) x 211 (depth) mm

MASS

2.1Kg (4.6 lbs)

REMOTE CONTROL UNIT

RC6400DV
 Infrared pulse type
 Supply: DC 3V, 2 R6P/AA batteries

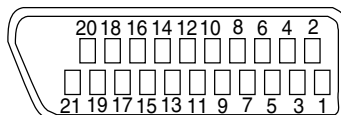

Contacts, signal levels and impedances

<i>Contact 1</i>	Audio Output (Right):	2.0Vrms/ 1kΩ
<i>Contact 3</i>	Audio Output (Left):	2.0Vrms/ 1kΩ
<i>Contact 4</i>	Audio, Ground	
<i>Contact 5</i>	RGB, Ground (Blue)	
<i>Contact 7</i>	RGB Output (Blue):	0.7Vp-p/75Ω
<i>Contact 8</i>	Function Select Switching Control	
	L :	0.0~2.0V DC Power Off
	M :	4.5~7.0V DC Wide-Screen Mode (16:9)
	H :	9.5~12.0V DC Normal Mode (4:3)
<i>Contact 9</i>	RGB, Ground (Green)	
<i>Contact 11</i>	RGB Output (Green):	0.7Vp-p/75Ω
<i>Contact 13</i>	RGB, Ground (Red)	
<i>Contact 14</i>	RGB Switching Control, Ground	
<i>Contact 15</i>	RGB Output (Red):	0.7Vp-p/75Ω
<i>Contact 16</i>	RGB Switching Control	
	H :	3.3V DC RGB Mode
<i>Contact 17</i>	Video Output Signal, Ground	
<i>Contact 18</i>	Video Input Signal, Ground	
<i>Contact 19</i>	Video Output (CVBS):	1.0Vp-p/75Ω
<i>Contact 21</i>	Common Ground (shielding)	

Playable Discs

The following discs can be played back on this DVD player.

Usable discs	Mark (logo)	Recorded signals	Disc Size
DVD-Video (NOTE 1)		Digital video (MPEG2)	12 cm
DVD-R DVD-RW (NOTE 2)			8 cm
CD CD-R CD-RW (NOTE 3)		Digital audio MP3 WMA (NOTE 4) Digital picture (JPEG)	12 cm 8 cm
Video CD		Sound and Pictures	12 cm 8 cm (Singles)
Picture CD			JPEG

- NOTE 1: Some DVD-Video discs do not operate as described in this manual due to the intentions of the discs' producers.
- NOTE 2: Playing DVD-R and DVD-RW discs on a DVD recorder can be played. Discs that have not been finalized cannot be played. Depending on the disc's recording status, the disc may not be accepted or may not be played normally (the picture or sound may not be smooth, etc.).
- NOTE 3: Some of CD-R/CD-RW discs may be incompatible because of "scratch and stain of disc", "Recording condition", and "Characteristic of Recorder".
- NOTE 4: Windows Media and the Windows logo are trademarks or registered trademarks of Microsoft Corporation in the United States and/or other countries.

This player conforms to the PAL colour system. Also you can play discs recorded with the NTSC system via a PAL system TV set.

- Some discs include region codes as shown below.



- The number inside the symbol refers to a region of the world, and a disc encoded in a specific region format can only be played back on DVD players with the same region code.

The following discs cannot be played back on this DVD player.

- DVD with region codes other than 2 or ALL.
- DVD-ROM
- DVD-RAM (Never play back, otherwise malfunction may result.)
- CD-ROM
- VSD
- CDV (Only plays back the audio part.)
- CD-G (Only plays back the sound.)
- CD-R/CD-RW (Only plays back the discs which audio CD/MP3/JPEG/WMA is recorded.)
- CD-I (Never play back, otherwise malfunction may result.)
- Photo CD (Never play back, otherwise malfunction may result.)
- SUPER AUDIO CD
- DVD-Audio

Any other discs without compatibility indications.

Disc Types

[DVD-Video]

Data on a DVD is divided into sections called "titles," and then into subsections called "chapters," each of which is given a title or chapter number. Playback conditions are preset on some DVD-Video discs, and these playback conditions take priority over user operations on this player. If a function you selected does not run as desired, refer to the manual accompanying the disc.

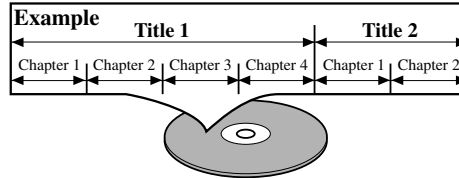

[AUDIO CD, Video CD]

Data on an AUDIO CD, or a Video CD is divided into sections called "tracks," each of which is given a track number.

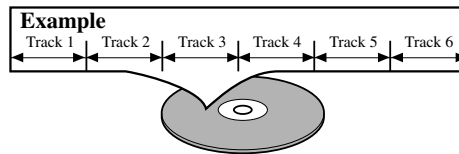

ABOUT THE PBC FUNCTION OF VIDEO CD

This unit conforms to ver.1.1 and ver.2.0 of Video CD standard, with PBC function.

Ver.1.1 (without PBC function): You can enjoy playback picture as well as music CD.

Ver.2.0 (with PBC function): While using a Video CD with PBC function, "PBC" appears on the screen and the display.

What is PBC? "PBC" stands for the Playback Control. You can play interactive software using menu screens. Refer to instructions in the Video CD.

NOTE:

When playing Video CDs with PBC function, some operations (e.g., select and repeat tracks) cannot be performed unless the function is cancelled temporarily (refer to page 15).

[MP3, JPEG, WMA]

Data on a MP3 is divided into sections called "groups," and then into subsections called "tracks," each of which is given an album or track number.

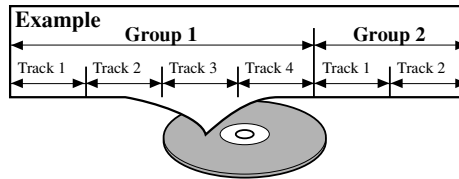

CAUTION:

- Use caution not to pinch your finger in the disc slot.
- Be sure to remove a disc and unplug the AC power cord from the outlet before carrying the DVD player.

TECHNICAL SPECIFICATIONS

[DV6400]

SIGNAL SYSTEM

PAL color

APPLICABLE DISCS

- (1) DVD-Audio/DVD-Video Discs
 - 1-layer 12cm single-sided discs, 2-layer 12cm single-sided discs, 2-layer 12cm double-sided discs (1 layer per side)
 - 1-layer 8cm single-sided discs, 2-layer 8cm single-sided discs, 2-layer 8cm double-sided discs (1 layer per side)
- (2) Super Audio CD
- (3) DVD-R/DVD-RW
- (4) Compact discs (CD-DA)
 - 12cm discs, 8cm discs
- (5) CD-R/CD-RW

S-VIDEO OUTPUT

Y output level: 1Vp-p (75Ω/ohms)
 C output level: 0.30Vp-p
 Output connectors: S connectors, 1 set

VIDEO OUTPUT

Output level: 1Vp-p (75Ω/ohms)
 Output connector: Pin jacks, 1 set

COMPONENT OUTPUT

Y output level: 1Vp-p (75Ω/ohms)
 C_B output level: 0.7Vp-p (75Ω/ohms)
 C_R output level: 0.7Vp-p (75Ω/ohms)
 Output connector: Pin jacks, 1 set

AUDIO/VIDEO

21-pin scart jack

AUDIO OUTPUT

Output level: 2Vrms
 2 channel (L, R) output connector: Pin jack, 1 set
 Multi channel (FL, FR, C, SW, SL, SR) output connector: Pinjack, 1 set

AUDIO OUTPUT PROPERTIES

- (1) Frequency response
 - 1 DVDs (linear PCM) : 4Hz to 22kHz (48 kHz sampling)
 - : 4Hz to 44kHz (96 kHz sampling)
 - : 4Hz to 88kHz (192 kHz sampling)
 - 2 CDs : 4Hz to 20kHz
 - 3 Super Audio CD : 4Hz to 100kHz
- (2) S/N ratio : 115dB
- (3) Total harmonic distortion : 1kHz CD: 0.003%
- (4) Dynamic range : DVD: 100dB
 CD: 98dB

DIGITAL AUDIO OUTPUT

Optical digital output: Optical connector, 1 set
 Coaxial digital output: Pin jack, 1 set

POWER SUPPLY

AC 230V, 50Hz

POWER CONSUMPTION

16W (Standby: 1.2W)

MAXIMUM EXTERNAL DIMENSIONS

440 (width) x 75 (height) x 211 (depth) mm

MASS

2.2Kg (4.9lbs)

REMOTE CONTROL UNIT

RC6400DV
 Infrared pulse type
 Supply: DC 3V, 2 R6P/AA batteries

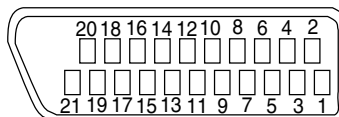

Contacts, signal levels and impedances

<i>Contact 1</i>	Audio Output (Right):	2.0Vrms/ 1kΩ
<i>Contact 3</i>	Audio Output (Left):	2.0Vrms/ 1kΩ
<i>Contact 4</i>	Audio, Ground	
<i>Contact 5</i>	RGB, Ground (Blue)	
<i>Contact 7</i>	RGB Output (Blue):	0.7Vp-p/75Ω
<i>Contact 8</i>	Function Select Switching Control	
		L : 0.0~2.0V DC Power Off
		M: 4.5~7.0V DC Wide-Screen Mode (16:9)
		H: 9.5~12.0V DC Normal Mode (4:3)
<i>Contact 9</i>	RGB, Ground (Green)	
<i>Contact 11</i>	RGB Output (Green):	0.7Vp-p/75Ω
<i>Contact 13</i>	RGB, Ground (Red)	
<i>Contact 14</i>	RGB Switching Control, Ground	
<i>Contact 15</i>	RGB Output (Red):	0.7Vp-p/75Ω
<i>Contact 16</i>	RGB Switching Control	
	H: 3.3V DC	RGB Mode
<i>Contact 17</i>	Video Output Signal, Ground	
<i>Contact 18</i>	Video Input Signal, Ground	
<i>Contact 19</i>	Video Output (CVBS):	1.0Vp-p/75Ω
<i>Contact 21</i>	Common Ground (shielding)	

Playable Discs

The following discs can be played back on this DVD player.

Usable discs	Mark (logo)	Recorded signals	Disc Size
DVD-Audio			12 cm
DVD-Video (NOTE 1)		Digital video (MPEG2)	8 cm
DVD-R DVD-RW (NOTE 2)			
CD CD-R CD-RW (NOTE 3)		Digital audio MP3 WMA (NOTE 4) Digital picture (JPEG)	12 cm 8 cm
Super Audio CD		Digital audio	12 cm
Video CD		Sound and Pictures	12 cm 8 cm (Singles)
Picture CD		JPEG	12 cm

- NOTE 1: Some DVD-Video discs do not operate as described in this manual due to the intentions of the discs' producers.
- NOTE 2: Playing DVD-R and DVD-RW discs on a DVD recorder can be played. DVD-R and DVD-RW discs on a DVD recorder can be played. Discs that have not been finalized cannot be played. Depending on the disc's recording status, the disc may not be accepted or may not be played normally (the picture or sound may be not be smooth, etc.).
- NOTE 3: Some of CD-R/CD-RW discs may be incompatible because of "scratch and stain of disc", "Recording condition", and "Characteristic of Recorder".
- NOTE 4: Windows Media and the Windows logo are trademarks or registered trademarks of Microsoft Corporation in the United States and/or other countries.

This player conforms to the PAL colour system. Also you can play discs recorded with the NTSC system via a PAL system TV set.

- Some discs include region codes as shown below.



- The number inside the symbol refers to a region of the world, and a disc encoded in a specific region format can only be played back on DVD players with the same region code.

The following discs cannot be played back on this DVD player.

- DVD with region codes other than 2 or ALL.
- DVD-ROM
- DVD-RAM (Never play back, otherwise malfunction may result.)
- CD-ROM
- VSD
- CDV (Only plays back the audio part.)
- CD-G (Only plays back the sound.)
- CD-R/CD-RW (Only plays back the discs which audio CD/MP3/JPEG/WMA is recorded.)
- CD-I (Never play back, otherwise malfunction may result.)
- Photo CD (Never play back, otherwise malfunction may result.)

Any other discs without compatibility indications.

Disc Types

[DVD-Audio]

DVD-Audios are divided into several large sections called "groups" and smaller sections called "tracks." Numbers are allotted to these sections. These numbers are called "group numbers" and "track numbers."

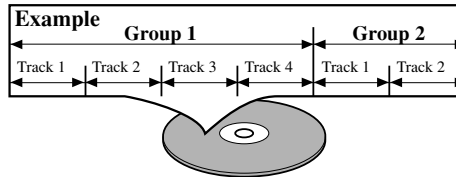

[DVD-Video]

Data on a DVD is divided into sections called "titles," and then into subsections called "chapters," each of which is given a title or chapter number. Playback conditions are preset on some DVD-Video discs, and these playback conditions take priority over user operations on this player. If a function you selected does not run as desired, refer to the manual accompanying the disc.

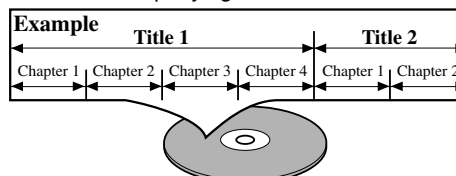

[AUDIO CD, Video CD, SUPER AUDIO CD]

Data on an AUDIO CD, a SUPER AUDIO CD, or a Video CD is divided into sections called "tracks," each of which is given a track number.

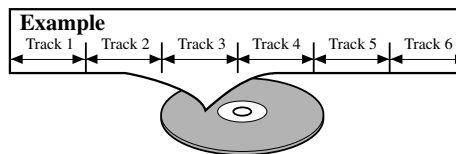

ABOUT THE PBC FUNCTION OF VIDEO CD

This unit conforms to ver.1.1 and ver.2.0 of Video CD standard, with PBC function.

Ver.1.1 (without PBC function): You can enjoy playback picture as well as music CD.

Ver.2.0 (with PBC function): While using a Video CD with PBC function, "PBC" appears on the screen and the display.

What is PBC? "PBC" stands for the Playback Control. You can play interactive software using menu screens. Refer to instructions in the Video CD.

NOTE:

When playing Video CDs with PBC function, some operations (e.g., select and repeat tracks) cannot be performed unless the function is cancelled temporarily (refer to page 16).

[MP3, JPEG, WMA]

Data on a MP3 is divided into sections called "groups," and then into subsections called "tracks," each of which is given an album or track number.

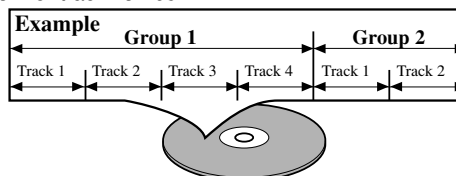

CAUTION:

- Use caution not to pinch your finger in the disc slot.
- Be sure to remove a disc and unplug the AC power cord from the outlet before carrying the DVD player.

SERVICE HINTS AND TOOLS

SERVICE HINTS

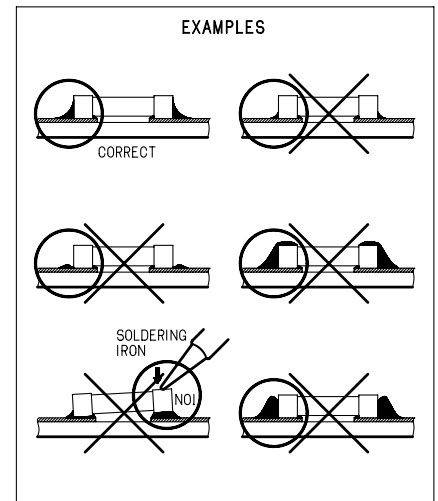
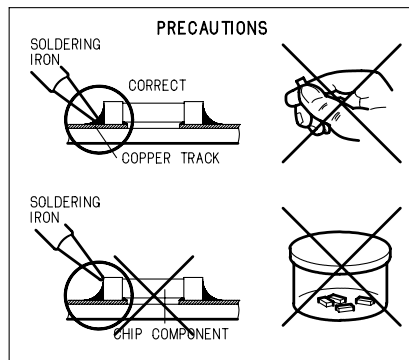
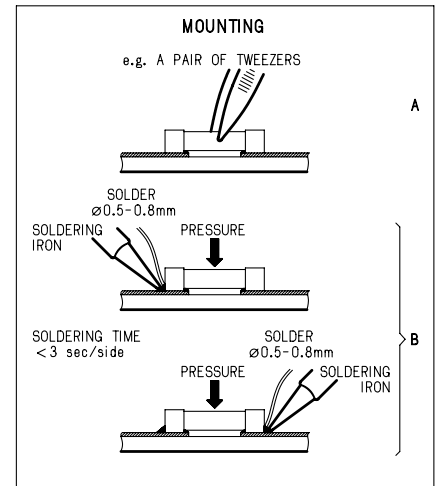
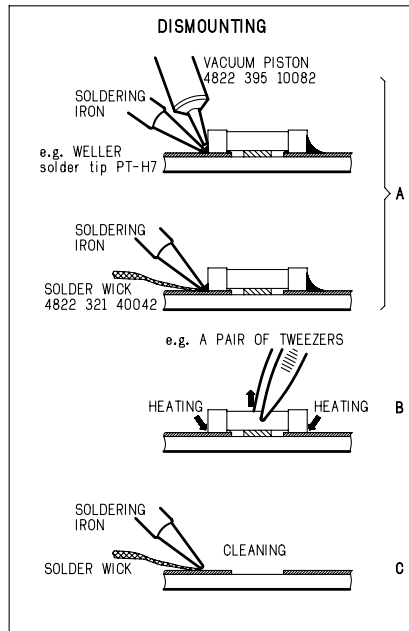
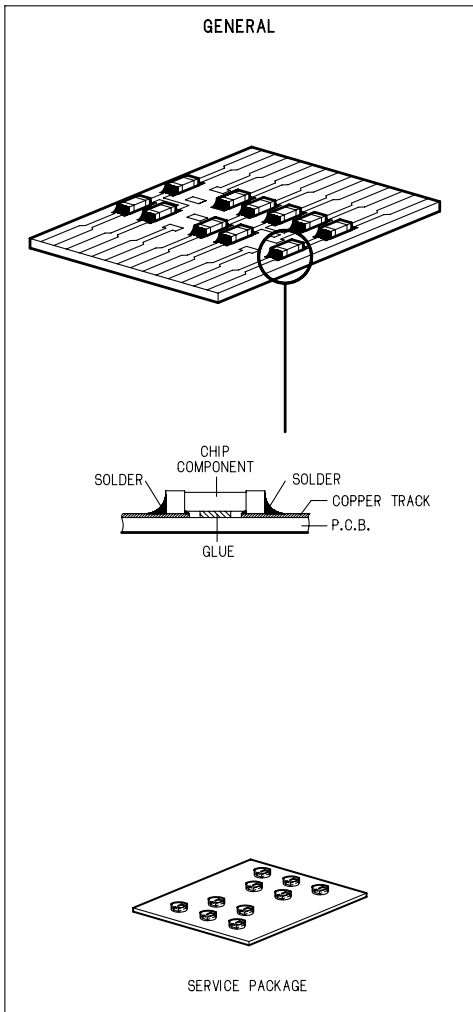

SERVICE TOOLS

Audio signals disc	4822 397 30184
Disc without errors (SBC444)+	
Disc with DO errors, black spots and fingerprints (SBC444A)	4822 397 30245
Disc (65 min 1kHz) without no pause	4822 397 30155
Max. diameter disc (58.0 mm)	4822 397 60141
Torx screwdrivers	
Set (straight)	4822 395 50145
Set (square)	4822 395 50132
13th order filter	4822 395 30204
DVD test disc (PAL)	4822 397 10131
DVD test disc (NTSC) ALMEDIO	TDV-540

WARNING AND LASER SAFETY INSTRUCTIONS

(GB)

WARNING

All ICs and many other semi-conductors are susceptible to electrostatic discharges (ESD). Careless handling during repair can reduce life drastically.

When repairing, make sure that you are connected with the same potential as the mass of the set via a wrist wrap with resistance.

Keep components and tools also at this potential.

ESD



(NL)

WAARSCHUWING

Alle IC's en vele andere halfgeleiders zijn gevoelig voor elektrostatische ontladingen (ESD).

Onzorgvuldig behandelen tijdens reparatie kan de levensduur drastisch doen verminderen.

Zorg ervoor dat u tijdens reparatie via een polsband met weerstand verbonden bent met hetzelfde potentiaal als de massa van het apparaat.

Houd componenten en hulpmiddelen ook op ditzelfde potentiaal.

(F)

ATTENTION

Tous les IC et beaucoup d'autres semi-conducteurs sont sensibles aux décharges statiques (ESD).

Leur longévité pourrait être considérablement écourtée par le fait qu'aucune précaution n'est prise à leur manipulation.

Lors de réparations, s'assurer de bien être relié au même potentiel que la masse de l'appareil et enfiler le bracelet serti d'une résistance de sécurité.

Veiller à ce que les composants ainsi que les outils que l'on utilise soient également à ce potentiel.

(D)

WARNUNG

Alle IC und viele andere Halbleiter sind empfindlich gegen elektrostatische Entladungen (ESD).

Unorgfältige Behandlung bei der Reparatur kann die Lebensdauer drastisch vermindern. Sorgen sie dafür, das Sie im Reparaturfall über ein Pulsarmband mit Widerstand mit dem Massepotential des Gerätes verbunden sind.

Halten Sie Bauteile und Hilfsmittel ebenfalls auf diesem Potential.

(I)

AVVERTIMENTO

Tutti IC e parecchi semi-conduttori sono sensibili alle scariche statiche (ESD).

La loro longevita potrebbe essere fortemente ridatta in caso di non osservazione della più grande cauzione alla loro manipolazione.

Durante le riparazioni occorre quindi essere collegato allo stesso potenziale che quello della massa dell'apparecchio tramite un braccialetto a resistenza.

Assicurarsi che i componenti e anche gli utensili con quali si lavora siano anche a questo potenziale.

(GB)

Safety regulations require that the set be restored to its original condition and that parts which are identical with those specified be used.

(NL)

Veiligheidsbepalingen vereisen, dat het apparaat in zijn oorspronkelijke toestand wordt terug gebracht en dat onderdelen, identiek aan de gespecificeerde worden toegepast.

(D)

Bei jeder Reparatur sind die geltenden Sicherheitsvorschriften zu beachten. Der Originalzustand des Gerats darf nicht verändert werden. Für Reparaturen sind Original-Ersatzteile zu verwenden.

(I)

Le norme di sicurezza esigono che l'apparecchio venga rimesso nelle condizioni originali e che siano utilizzati pezzi di ricambio identici a quelli specificati.

"Pour votre sécurité, ces documents doivent être utilisés par des spécialistes agréés, seuls habilités à réparer votre appareil en panne."

(F)

Les normes de sécurité exigent que l'appareil soit remis à l'état d'origine et que soient utilisées les pièces de rechange identiques à celles spécifiées.

LASER SAFETY

This unit employs a laser. Only a qualified service person should remove the cover or attempt to service this device, due to possible eye injury.



USE OF CONTROLS OR ADJUSTMENTS OR PERFORMANCE OF PROCEDURE OTHER THAN THOSE SPECIFIED HEREIN MAY RESULT IN HAZARDOUS RADIATION EXPOSURE.

AVOID DIRECT EXPOSURE TO BEAM

WARNING

The use of optical instruments with this product will increase eye hazard.

Repair handling should take place as much as possible with a disc loaded inside the player

WARNING LOCATION: INSIDE ON LASER COVERSIELD

CAUTION VISIBLE AND INVISIBLE LASER RADIATION WHEN OPEN AVOID EXPOSURE TO BEAM
ADVARSEL SYNLIG OG USYNLIG LASERSTRÅLING VED ÅBNING UNDGÅ UDSÆTTELSE FOR STRÅLING
ADVARSEL SYNLIG OG USYNLIG LASERSTRÅLING NÅR DEKSEL Å PNE UNNGÅ EKSPONERING FOR STRÅLEN
VARNING SYNLIG OCH OSYNLIG LASERSTRÅLNING NÅR DENNA DEL ÅR ÖPPNAD BETRAKTA EJ STRÅLEN
VARO! AVATT AESSA OLET ALTTIINA NÄKYVÄLLE JA NÄKYMÄTTÖMÄLLE LASER SÄTEILYLLE. ÄLÄ KATSO SÄTEESEEN
VORSICHT SICHTBARE UND UNSICHTBARE LASERSTRAHLUNG WENN ABDECKUNG GEÖFFNET NICHT DEM STRAHL AUSSETSEN
DANGER VISIBLE AND INVISIBLE LASER RADIATION WHEN OPEN AVOID DIRECT EXPOSURE TO BEAM
ATTENTION RAYONNEMENT LASER VISIBLE ET INVISIBLE EN CAS D'OUVERTURE EXPOSITION DANGEREUSE AU FAISCEAU

LASER BEAM SAFETY PRECAUTIONS

This DVD player uses a pickup that emits a laser beam.

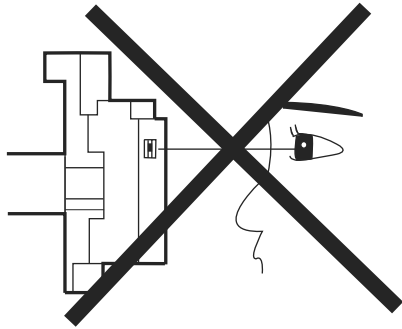

Do not look directly at the laser beam coming from the pickup or allow it to strike against your skin.

The laser beam is emitted from the location shown in the figure. When checking the laser diode, be sure to keep your eyes at least 30cm away from the pickup lens when the diode is turned on. Do not look directly at the laser beam.

Caution: Use of controls and adjustments, or doing procedures other than those specified herein, may result in hazardous radiation exposure.

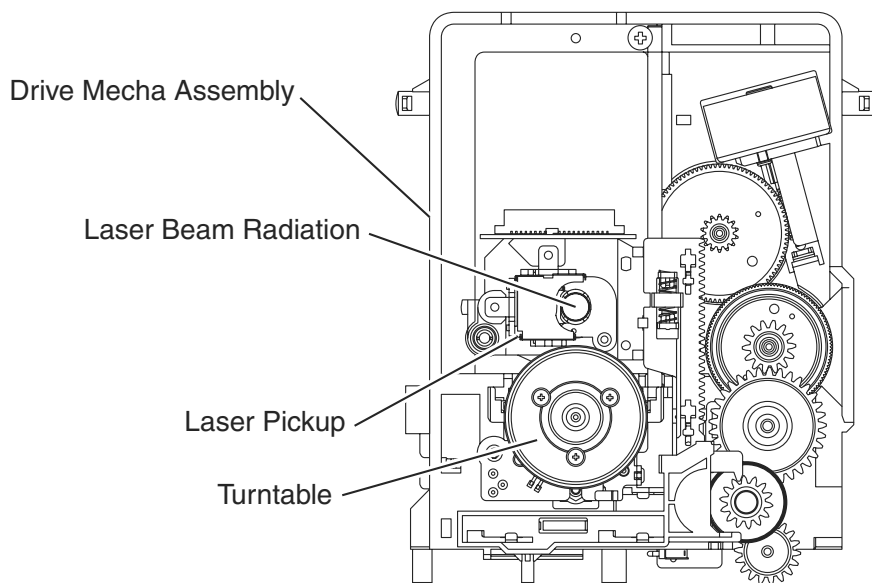

IMPORTANT SAFETY PRECAUTIONS

Product Safety Notice

Some electrical and mechanical parts have special safety-related characteristics which are often not evident from visual inspection, nor can the protection they give necessarily be obtained by replacing them with components rated for higher voltage, wattage, etc. Parts that have special safety characteristics are identified by a  on schematics and in parts lists. Use of a substitute replacement that does not have the same safety characteristics as the recommended replacement part might create shock, fire, and/or other hazards. The Product's Safety is under review continuously and new instructions are issued whenever appropriate. Prior to shipment from the factory, our products are carefully inspected to confirm with the recognized product safety and electrical codes of the countries in which they are to be sold. However, in order to maintain such compliance, it is equally important to implement the following precautions when a set is being serviced.

Precautions during Servicing

- A. Parts identified by the  symbol are critical for safety. Replace only with part number specified.
- B. In addition to safety, other parts and assemblies are specified for conformance with regulations applying to spurious radiation. These must also be replaced only with specified replacements.
Examples: RF converters, RF cables, noise blocking capacitors, and noise blocking filters, etc.
- C. Use specified internal wiring. Note especially:
 - 1) Wires covered with PVC tubing
 - 2) Double insulated wires
 - 3) High voltage leads
- D. Use specified insulating materials for hazardous live parts. Note especially:
 - 1) Insulation tape
 - 2) PVC tubing
 - 3) Spacers
 - 4) Insulators for transistors
- E. When replacing AC primary side components (transformers, power cord, etc.), wrap ends of wires securely about the terminals before soldering.
- F. Observe that the wires do not contact heat producing parts (heatsinks, oxide metal film resistors, fusible resistors, etc.).
- G. Check that replaced wires do not contact sharp edges or pointed parts.
- H. When a power cord has been replaced, check that 5 - 6 kg of force in any direction will not loosen it.

- I. Also check areas surrounding repaired locations.
- J. Be careful that foreign objects (screws, solder droplets, etc.) do not remain inside the set.
- K. Crimp type wire connector
The power transformer uses crimp type connectors which connect the power cord and the primary side of the transformer. When replacing the transformer, follow these steps carefully and precisely to prevent shock hazards.
Replacement procedure
 - 1) Remove the old connector by cutting the wires at a point close to the connector.
Important: Do not re-use a connector. (Discard it.)
 - 2) Strip about 15 mm of the insulation from the ends of the wires. If the wires are stranded, twist the strands to avoid frayed conductors.
 - 3) Align the lengths of the wires to be connected. Insert the wires fully into the connector.
 - 4) Use a crimping tool to crimp the metal sleeve at its center. Be sure to crimp fully to the complete closure of the tool.
- L. When connecting or disconnecting the internal connectors, first, disconnect the AC plug from the AC outlet.

Safety Check after Servicing

Examine the area surrounding the repaired location for damage or deterioration. Observe that screws, parts, and wires have been returned to their original positions. Afterwards, do the following tests and confirm the specified values to verify compliance with safety standards.

1. Clearance Distance

When replacing primary circuit components, confirm specified clearance distance (d) and (d') between soldered terminals, and between terminals and surrounding metallic parts. (See Fig. 1)

Table 1 : Ratings for selected area

AC Line Voltage	Clearance Distance (d) (d')
230 V	$\geq 3 \text{ mm}(d)$ $\geq 6 \text{ mm}(d')$

Note: This table is unofficial and for reference only. Be sure to confirm the precise values.

2. Leakage Current Test

Confirm the specified (or lower) leakage current between B (earth ground, power cord plug prongs) and externally exposed accessible parts (RF terminals, antenna terminals, video and audio input and output terminals, microphone jacks, earphone jacks, etc.) is lower than or equal to the specified value in the table below.

Measuring Method (Power ON) :

Insert load Z between B (earth ground, power cord plug prongs) and exposed accessible parts. Use an AC voltmeter to measure across the terminals of load Z. See Fig. 2 and the following table.

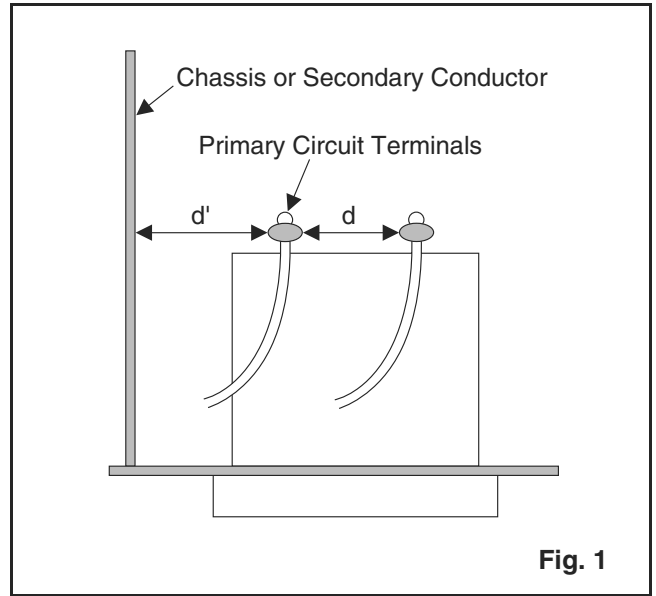

Fig. 1

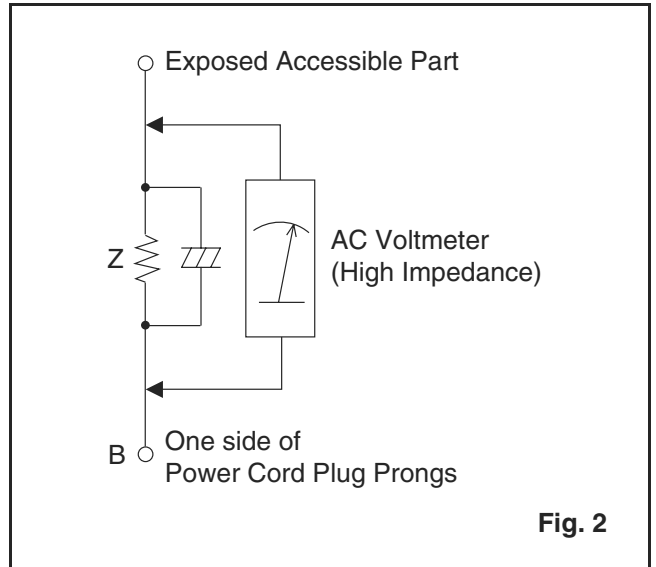

Fig. 2

Table 2: Leakage current ratings for selected areas

AC Line Voltage	Load Z	Leakage Current (i)	One side of power cord plug prongs (B) to:
230 V	2kΩ RES. Connected in parallel	$i \leq 0.7 \text{ mA AC Peak}$ $i \leq 2 \text{ mA DC}$	RF or Antenna terminals
	50kΩ RES. Connected in parallel	$i \leq 0.7 \text{ mA AC Peak}$ $i \leq 2 \text{ mA DC}$	A/V Input, Output

Note: This table is unofficial and for reference only. Be sure to confirm the precise values.

STANDARD NOTES FOR SERVICING

Circuit Board Indications

1. The output pin of the 3 pin Regulator ICs is indicated as shown.

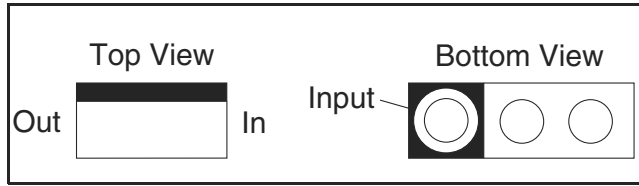

2. For other ICs, pin 1 and every fifth pin are indicated as shown.

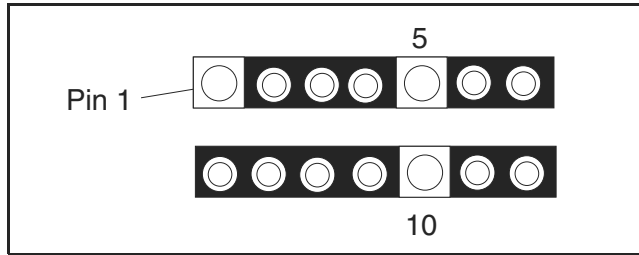

3. The 1st pin of every male connector is indicated as shown.

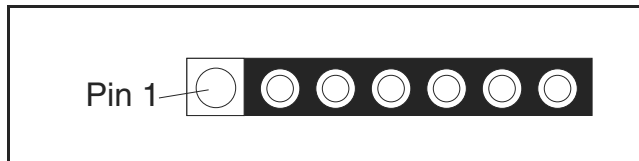

Instructions for Connectors

1. When you connect or disconnect the FFC (Flexible Foil Connector) cable, be sure to first disconnect the AC cord.
2. FFC (Flexible Foil Connector) cable should be inserted parallel into the connector, not at an angle.

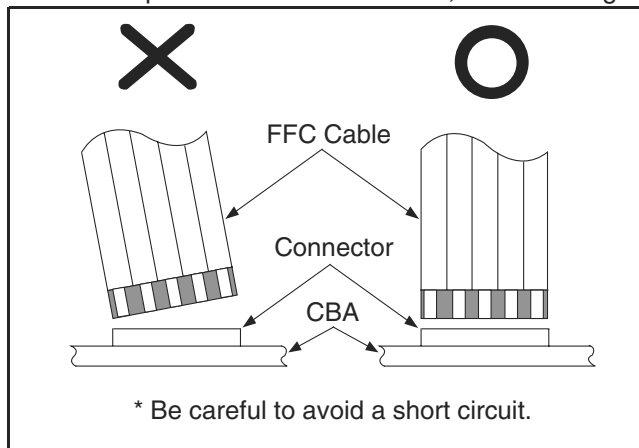

How to Remove / Install Flat Pack-IC

1. Removal

With Hot-Air Flat Pack-IC Desoldering Machine:

- (1) Prepare the hot-air flat pack-IC desoldering machine, then apply hot air to the Flat Pack-IC (about 5 to 6 seconds). (Fig. S-1-1)

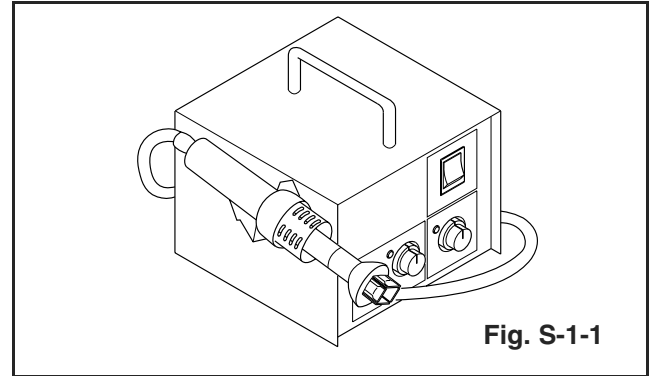

- (2) Remove the flat pack-IC with tweezers while applying the hot air.
- (3) Bottom of the flat pack-IC is fixed with glue to the CBA; when removing entire flat pack-IC, first apply soldering iron to center of the flat pack-IC and heat up. Then remove (glue will be melted). (Fig. S-1-6)
- (4) Release the flat pack-IC from the CBA using tweezers. (Fig. S-1-6)

Caution:

1. Do not supply hot air to the chip parts around the flat pack-IC for over 6 seconds because damage to the chip parts may occur. Put masking tape around the flat pack-IC to protect other parts from damage. (Fig. S-1-2)
2. The flat pack-IC on the CBA is affixed with glue, so be careful not to break or damage the foil of each pin or the solder lands under the IC when removing it.

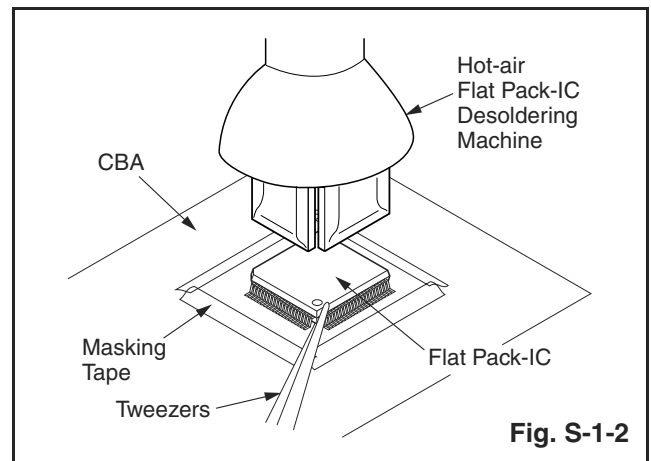

With Soldering Iron:

- (1) Using desoldering braid, remove the solder from all pins of the flat pack-IC. When you use solder flux which is applied to all pins of the flat pack-IC, you can remove it easily. (Fig. S-1-3)

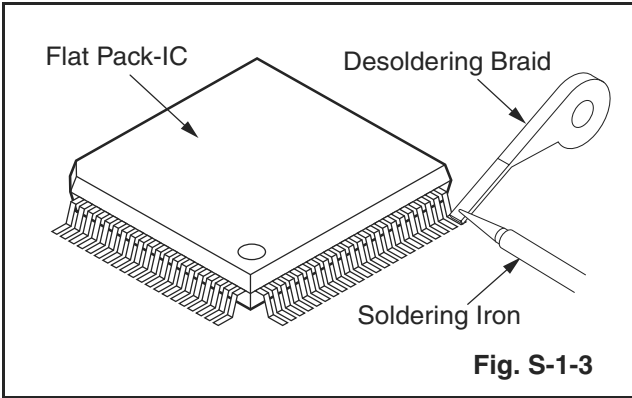

- (2) Lift each lead of the flat pack-IC upward one by one, using a sharp pin or wire to which solder will not adhere (iron wire). When heating the pins, use a fine tip soldering iron or a hot air desoldering machine. (Fig. S-1-4)

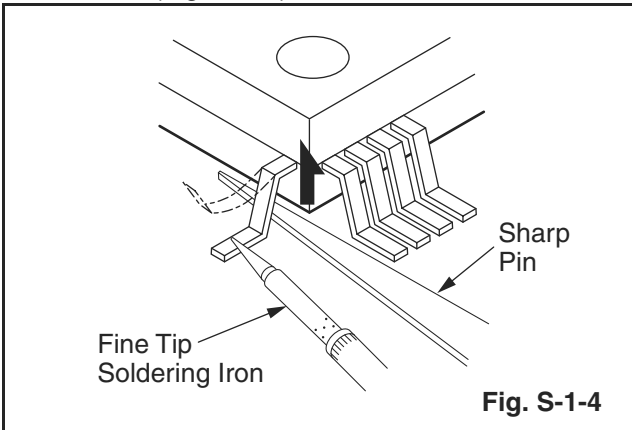

- (3) Bottom of the flat pack-IC is fixed with glue to the CBA; when removing entire flat pack-IC, first apply soldering iron to center of the flat pack-IC and heat up. Then remove (glue will be melted). (Fig. S-1-6)
- (4) Release the flat pack-IC from the CBA using tweezers. (Fig. S-1-6)

With Iron Wire:

- (1) Using desoldering braid, remove the solder from all pins of the flat pack-IC. When you use solder flux which is applied to all pins of the flat pack-IC, you can remove it easily. (Fig. S-1-3)
- (2) Affix the wire to a workbench or solid mounting point, as shown in Fig. S-1-5.
- (3) While heating the pins using a fine tip soldering iron or hot air blower, pull up the wire as the solder melts so as to lift the IC leads from the CBA contact pads as shown in Fig. S-1-5

- (4) Bottom of the flat pack-IC is fixed with glue to the CBA; when removing entire flat pack-IC, first apply soldering iron to center of the flat pack-IC and heat up. Then remove (glue will be melted). (Fig. S-1-6)
- (5) Release the flat pack-IC from the CBA using tweezers. (Fig. S-1-6)

Note:

When using a soldering iron, care must be taken to ensure that the flat pack-IC is not being held by glue. When the flat pack-IC is removed from the CBA, handle it gently because it may be damaged if force is applied.

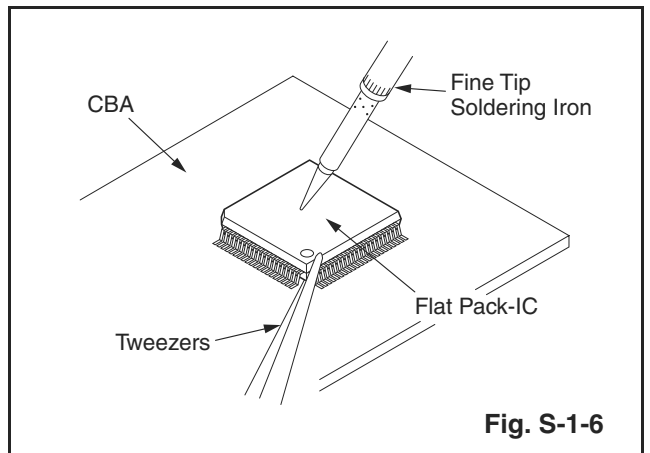
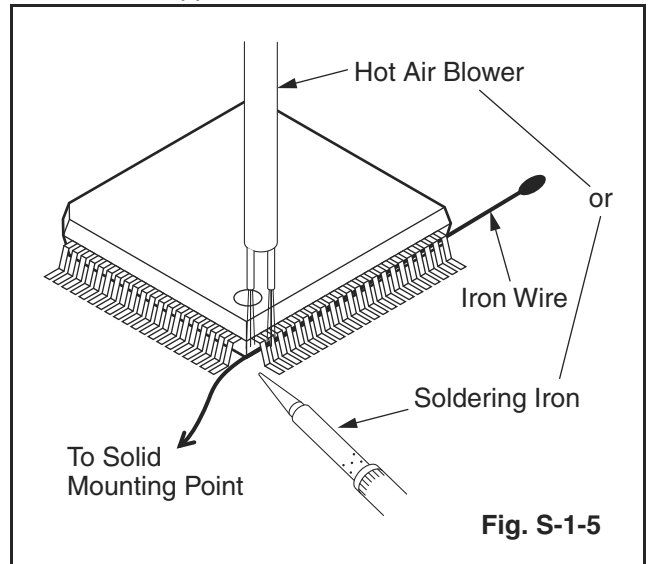

2. Installation

- (1) Using desoldering braid, remove the solder from the foil of each pin of the flat pack-IC on the CBA so you can install a replacement flat pack-IC more easily.
- (2) The "●" mark on the flat pack-IC indicates pin 1. (See Fig. S-1-7.) Be sure this mark matches the 1 on the PCB when positioning for installation. Then presolder the four corners of the flat pack-IC. (See Fig. S-1-8.)
- (3) Solder all pins of the flat pack-IC. Be sure that none of the pins have solder bridges.

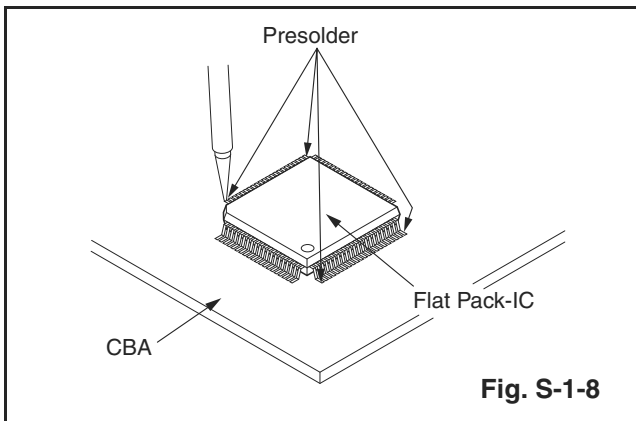
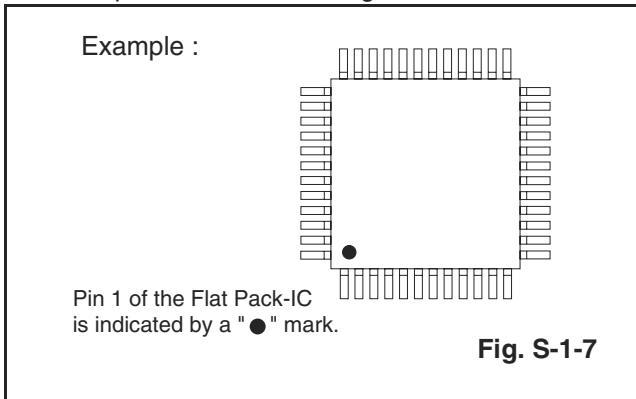

Instructions for Handling Semi-conductors

Electrostatic breakdown of the semi-conductors may occur due to a potential difference caused by electrostatic charge during unpacking or repair work.

1. Ground for Human Body

Be sure to wear a grounding band ($1M\Omega$) that is properly grounded to remove any static electricity that may be charged on the body.

2. Ground for Workbench

- (1) Be sure to place a conductive sheet or copper plate with proper grounding ($1M\Omega$) on the workbench or other surface, where the semi-conductors are to be placed. Because the static electricity charge on clothing will not escape through the body grounding band, be careful to avoid contacting semi-conductors with your clothing.

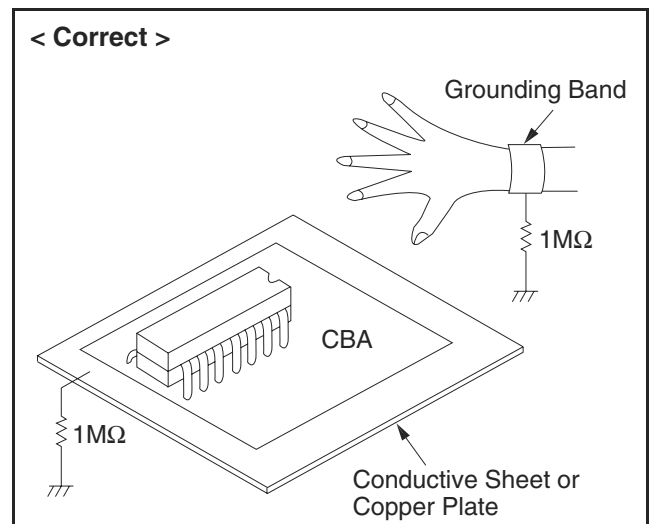
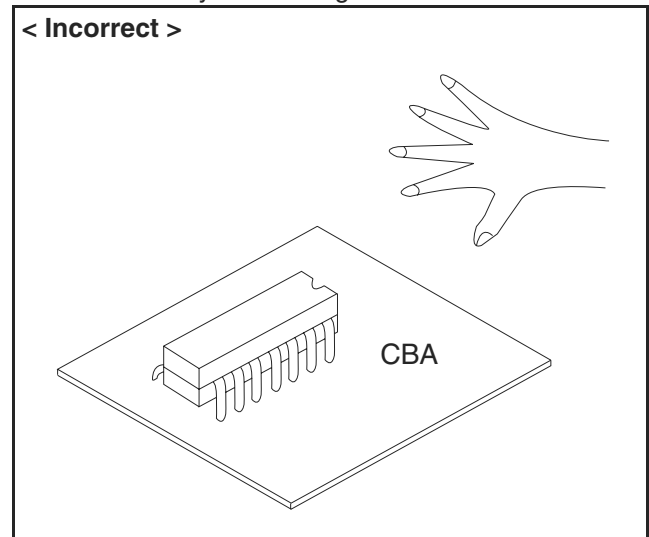

CABINET DISASSEMBLY INSTRUCTIONS

[DV4400/N1B, DV4400/N1S]

1. Disassembly Flowchart

This flowchart indicates the disassembly steps to gain access to item(s) to be serviced. When reassembling, follow the steps in reverse order. Bend, route, and dress the cables as they were originally.

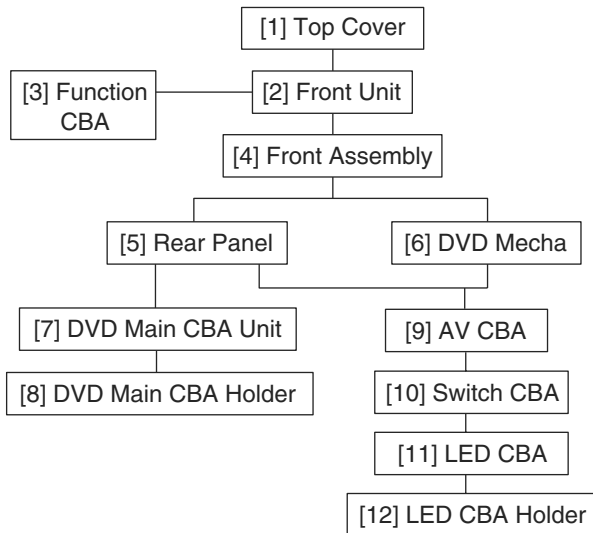

2. Disassembly Method

ID/ LOC. No.	PART	REMOVAL		
		Fig. No.	REMOVE/*UNHOOK/ UNLOCK/RELEASE/ UNPLUG/DESOLDER	Note
[1]	Top Cover	D1	5(S-1)	-
[2]	Front Unit	D2	*2(L-1), Tray Panel, *2(L-2), *5(L-3), *CN2002	1-1 1-2 1-3 1-4 1-5 1-6 1-7
[3]	Function CBA	D3	6(S-2), Insulation Sheet	-
[4]	Front Assembly	D3	-----	-
[5]	Rear Panel	D4	7(S-3), 3(S-4)	-
[6]	DVD Mecha	D5, D6	3(S-5), *CN201, *CN301	2 2-1 2-2 3
[7]	DVD Main CBA Unit	D5	2(S-6), *CN1001, *CN1601	-
[8]	DVD Main CBA Holder	D5	(S-7)	-
[9]	AV CBA	D7	4(S-8), *CN6001	-

ID/ LOC. No.	PART	REMOVAL		
		Fig. No.	REMOVE/*UNHOOK/ UNLOCK/RELEASE/ UNPLUG/DESOLDER	Note
[10]	Switch CBA	D7	(S-9), *2(L-4), Desolder	-
[11]	LED CBA	D7	(S-10), 3(L-5)	-
[12]	LED CBA Holder	D7	-----	-

↓ (1) ↓ (2) ↓ (3) ↓ (4) ↓ (5)

- (1): Identification (location) No. of parts in the figures
 (2): Name of the part
 (3): Figure Number for reference
 (4): Identification of parts to be removed, unhooked, unlocked, released, unplugged, unclamped, or desoldered.
 P=Spring, L=Locking Tab, S=Screw, CN=Connector
 *=Unhook, Unlock, Release, Unplug, or Desolder
 e.g. 2(S-2) = two Screws (S-2),
 2(L-2) = two Locking Tabs (L-2)
 (5): Refer to "Reference Notes."

Reference Notes

CAUTION 1: Locking Tabs (L-1), (L-2) and (L-3) are fragile. Be careful not to break them.

- 1-1. Connect the wall plug to an AC outlet and press the OPEN/CLOSE button to open the Tray.
- 1-2. Remove the Tray Panel by releasing two Locking Tabs (L-1).
- 1-3. Press the OPEN/CLOSE button again to close the Tray.
- 1-4. Press the POWER button to turn the power off.
- 1-5. Unplug an AC cord.
- 1-6. Disconnect connector CN2002.
- 1-7. Release two Locking Tabs (L-2). Then, release five Locking Tabs (L-3) (to do this, first release two Locking Tabs (A) at the side, and then three Locking Tabs (B) at the bottom.)

CAUTION 2: Electrostatic breakdown of the laser diode in the optical system block may occur as a potential difference caused by electrostatic charge accumulated on cloth, human body etc., during unpacking or repair work.

To avoid damage of pickup follow these procedures.

- 2-1. Disconnect connector (CN301). Remove three screws (S-5) and lift the DVD Mecha. (Fig. D5)

2-2. Short the three short lands of FPC cable with solder before removing the FFC cable (CN201) from it. If you disconnect the FFC cable (CN201), the laser diode of pickup will be destroyed. (Fig. D6)

CAUTION 3: When reassembling, confirm the FFC cable (CN201) is connected completely. Then remove the solder from the three short lands of FPC cable. (Fig. D6)

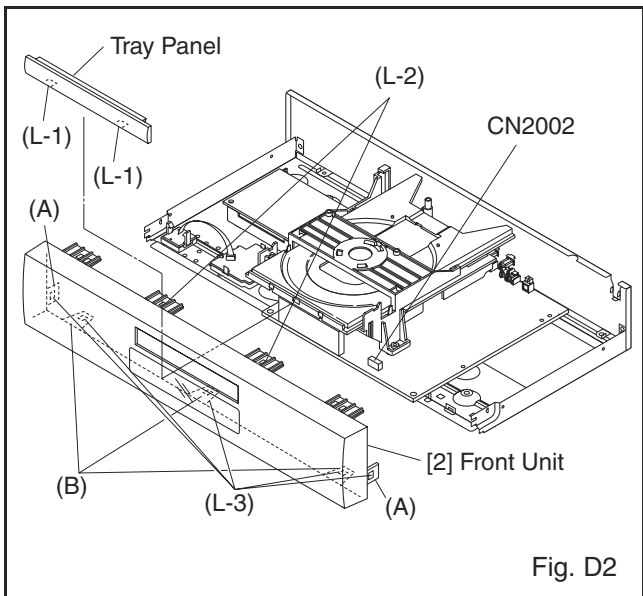
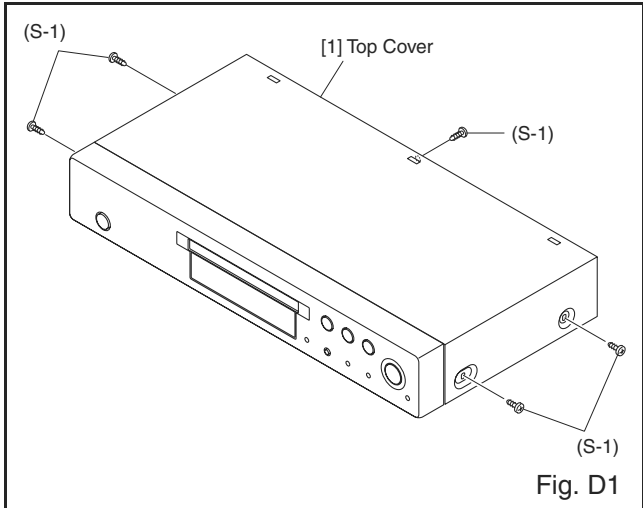
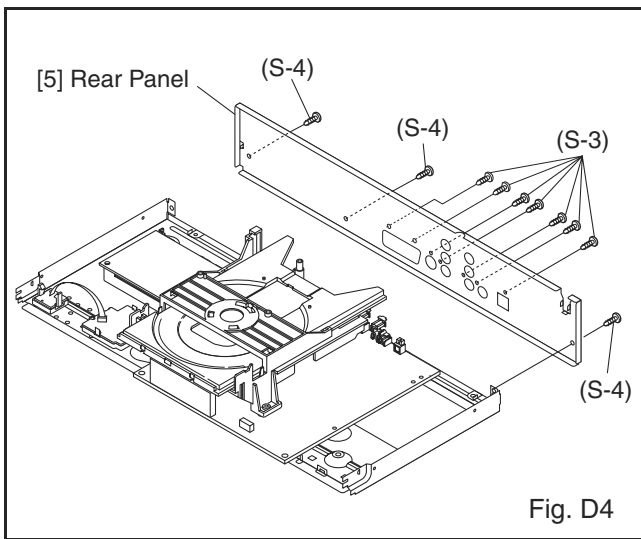
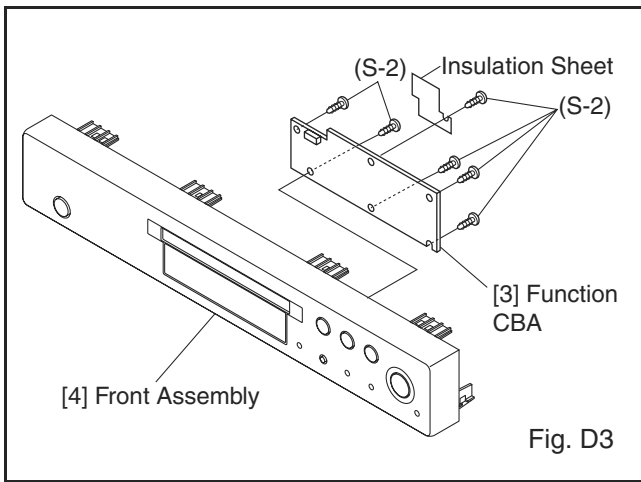

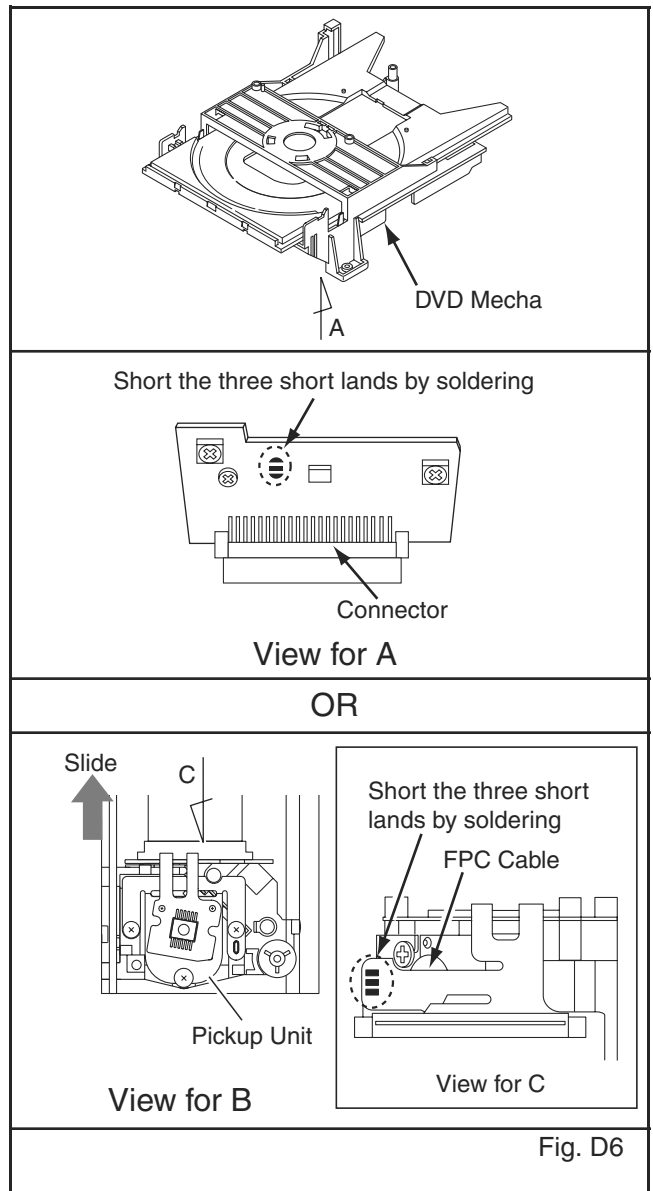
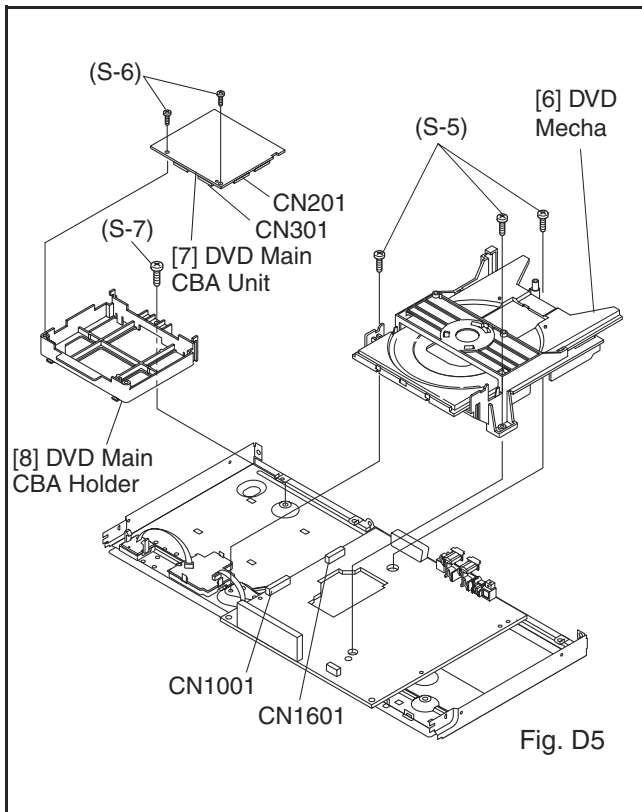

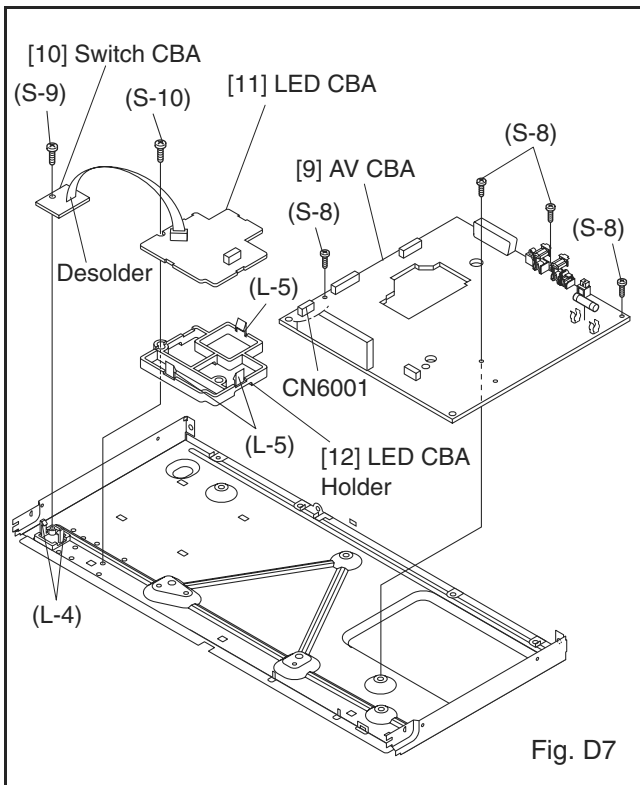

HOW TO MANUAL EJECT

1. Remove the Top Case.
2. Rotate the roulette in the direction of the arrow as shown below.

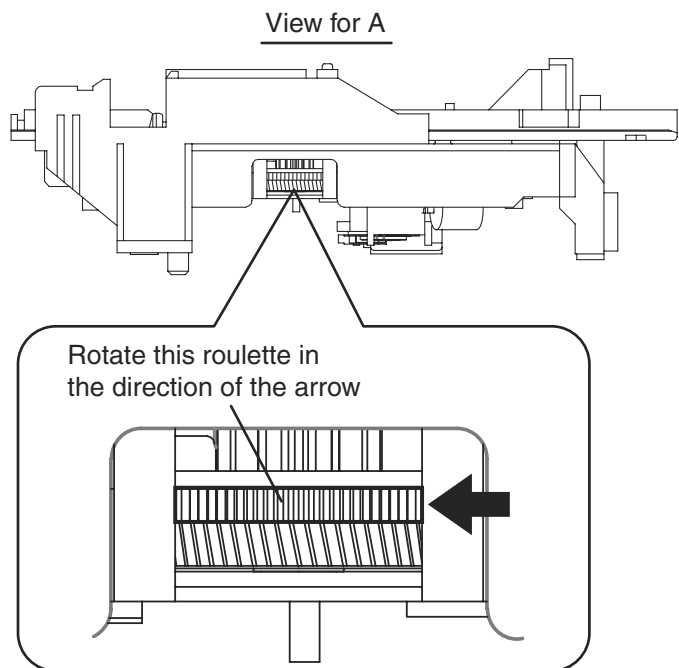
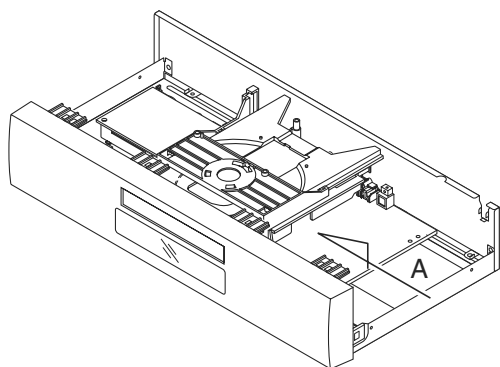

[DV6400/N1B, DV6400/N1S]

1. Disassembly Flowchart

This flowchart indicates the disassembly steps to gain access to item(s) to be serviced. When reassembling, follow the steps in reverse order. Bend, route, and dress the cables as they were originally.

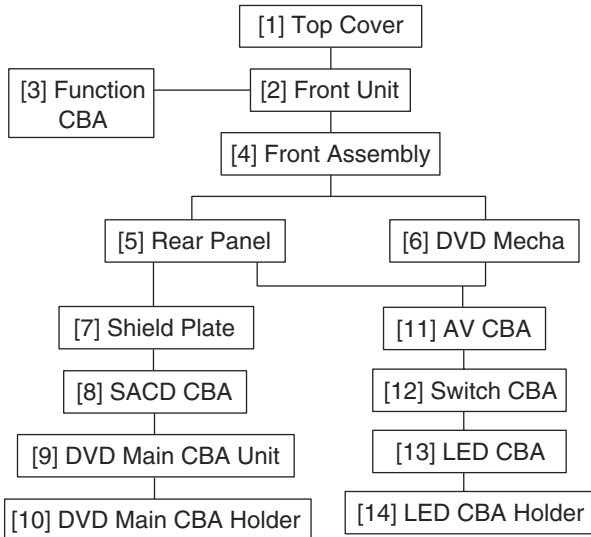

2. Disassembly Method

ID/ LOC. No.	PART	REMOVAL		
		Fig. No.	REMOVE/*UNHOOK/ UNLOCK/RELEASE/ UNPLUG/DESOLDER	Note
[1]	Top Cover	D8	5(S-11)	-
[2]	Front Unit	D9	*2(L-6), Tray Panel, *2(L-7), *5(L-8), *CN2002	1-1 1-2 1-3 1-4 1-5 1-6 1-7
[3]	Function CBA	D10	6(S-12), Insulation Sheet	-
[4]	Front Assembly	D10	-----	-
[5]	Rear Panel	D11	9(S-13), 3(S-14)	-
[6]	DVD Mecha	D12, D13	3(S-15), *CN201, *CN301	2 2-1 2-2 3
[7]	Shield Plate	D12	(S-16), 2(S-17)	-
[8]	SACD CBA	D12	*5(L-9), *CN7101, *CN7102, *CN7151	-
[9]	DVD Main CBA Unit	D12	2(S-18), *CN1001, *CN1601	-

ID/ LOC. No.	PART	REMOVAL		
		Fig. No.	REMOVE/*UNHOOK/ UNLOCK/RELEASE/ UNPLUG/DESOLDER	Note
[10]	DVD Main CBA Holder	D12	(S-19)	-
[11]	AV CBA	D14	4(S-20), *CN6001	-
[12]	Switch CBA	D14	(S-21), *2(L-10), Desolder	-
[13]	LED CBA	D14	(S-22), 3(L-11)	-
[14]	LED CBA Holder	D14	-----	-

(1) Identification (location) No. of parts in the figures
 (2) Name of the part
 (3) Figure Number for reference
 (4) Identification of parts to be removed, unhooked, unlocked, released, unplugged, unclamped, or desoldered.
 P=Spring, L=Locking Tab, S=Screw, CN=Connector
 *=Unhook, Unlock, Release, Unplug, or Desolder
 e.g. 2(S-2) = two Screws (S-2),
 2(L-2) = two Locking Tabs (L-2)
 (5) Refer to "Reference Notes."

- (1): Identification (location) No. of parts in the figures
 (2): Name of the part
 (3): Figure Number for reference
 (4): Identification of parts to be removed, unhooked, unlocked, released, unplugged, unclamped, or desoldered.
 P=Spring, L=Locking Tab, S=Screw, CN=Connector
 *=Unhook, Unlock, Release, Unplug, or Desolder
 e.g. 2(S-2) = two Screws (S-2),
 2(L-2) = two Locking Tabs (L-2)
 (5): Refer to "Reference Notes."

Reference Notes

CAUTION 1: Locking Tabs (L-6), (L-7) and (L-8) are fragile. Be careful not to break them.

- 1-1. Connect the wall plug to an AC outlet and press the OPEN/CLOSE button to open the Tray.
- 1-2. Remove the Tray Panel by releasing two Locking Tabs (L-6).
- 1-3. Press the OPEN/CLOSE button again to close the Tray.
- 1-4. Press the POWER button to turn the power off.
- 1-5. Unplug an AC cord.
- 1-6. Disconnect connector CN2002.
- 1-7. Release two Locking Tabs (L-7). Then, release five Locking Tabs (L-8) (to do this, first release two Locking Tabs (A) at the side, and then three Locking Tabs (B) at the bottom.)

CAUTION 2: Electrostatic breakdown of the laser diode in the optical system block may occur as a potential difference caused by electrostatic charge accumulated on cloth, human body etc., during unpacking or repair work.

To avoid damage of pickup follow these procedures.

2-1. Disconnect connector (CN301). Remove three screws (S-15) and lift the DVD Mecha. (Fig. D12)

2-2. Short the three short lands of FPC cable with solder before removing the FFC cable (CN201) from it. If you disconnect the FFC cable (CN201), the laser diode of pickup will be destroyed. (Fig. D13)

CAUTION 3: When reassembling, confirm the FFC cable (CN201) is connected completely. Then remove the solder from the three short lands of FPC cable. (Fig. D13)

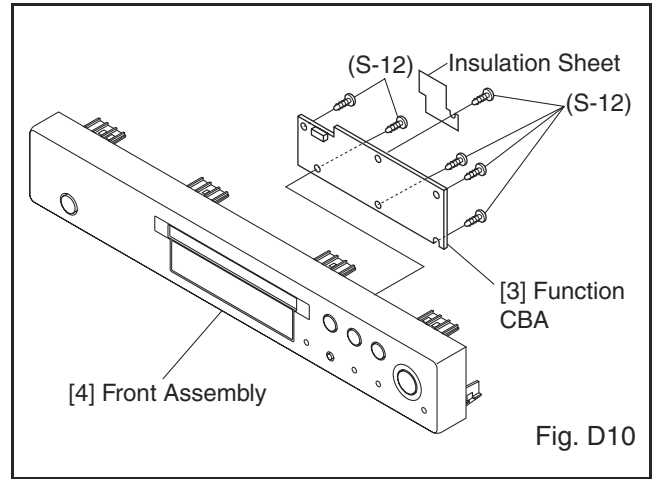

Fig. D10

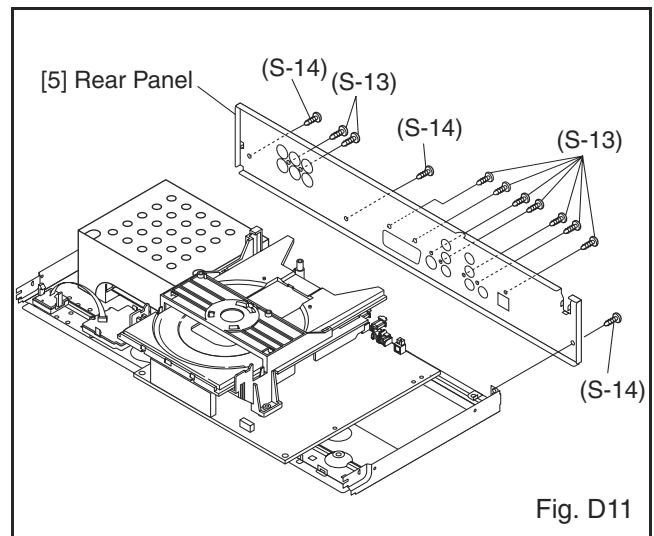

Fig. D11

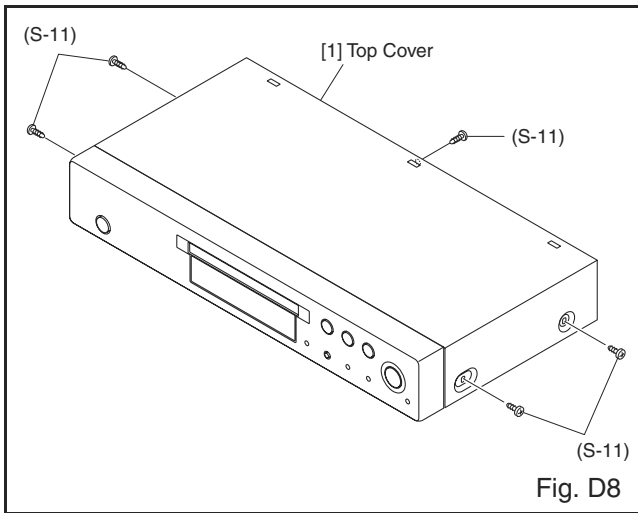

Fig. D8

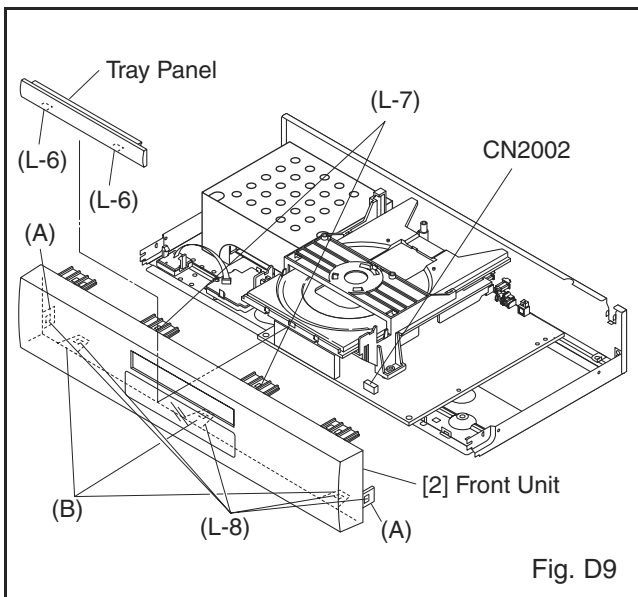
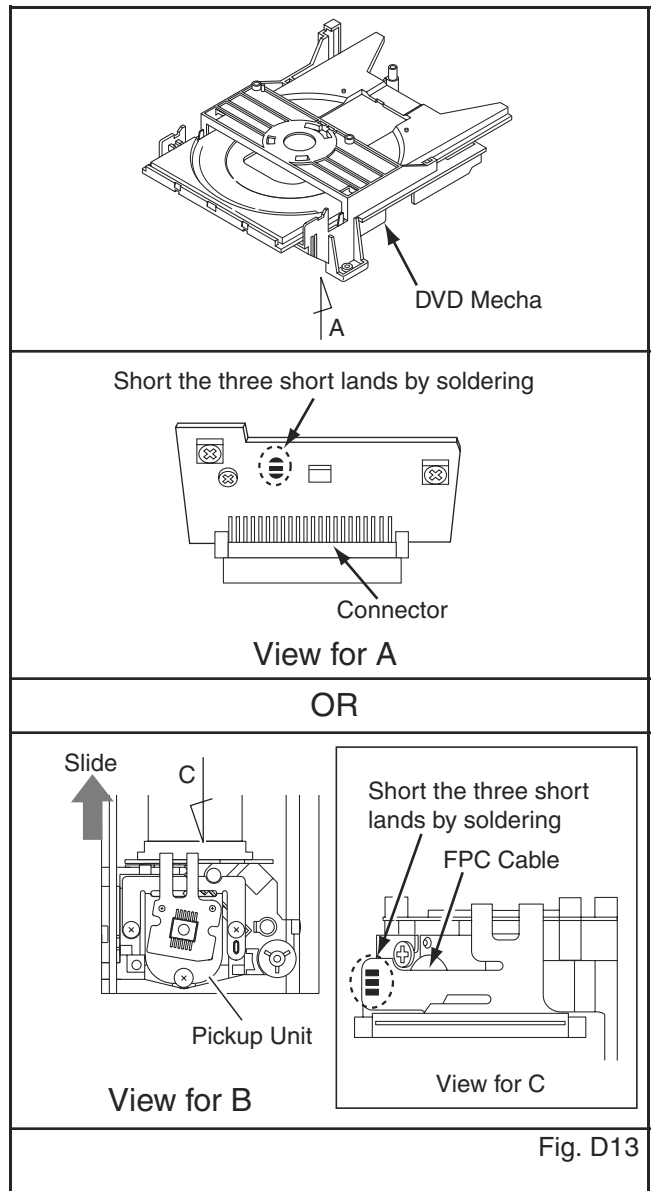
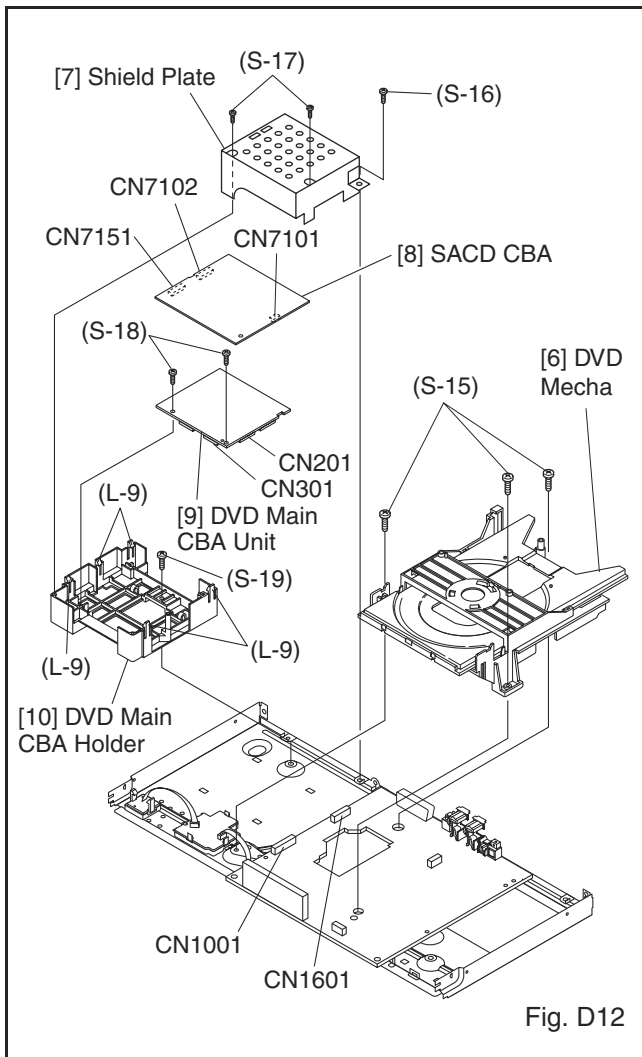

Fig. D9



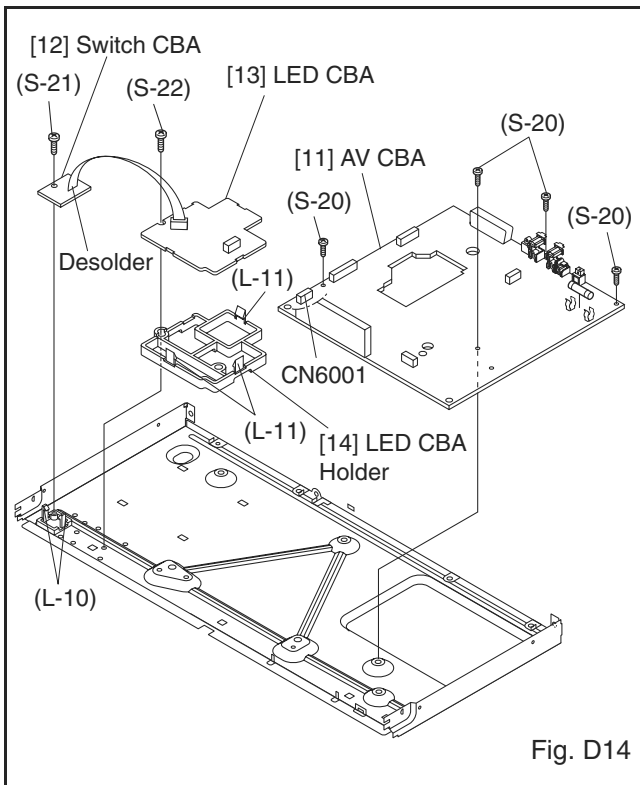
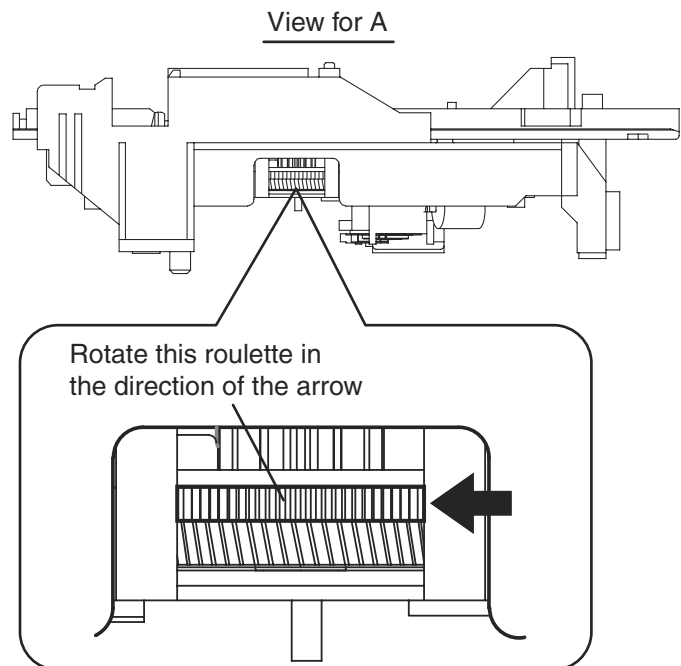
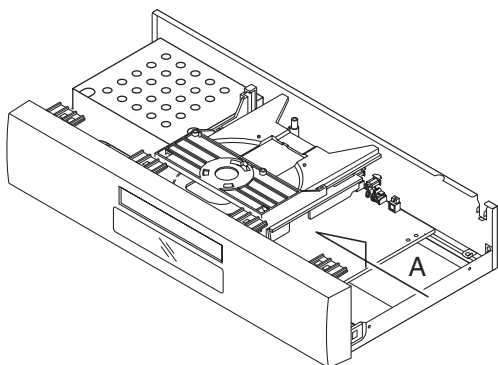

Fig. D14

HOW TO MANUAL EJECT

1. Remove the Top Case.
2. Rotate the roulette in the direction of the arrow as shown below.



TROUBLESHOOTING

FLOW CHART NO.1

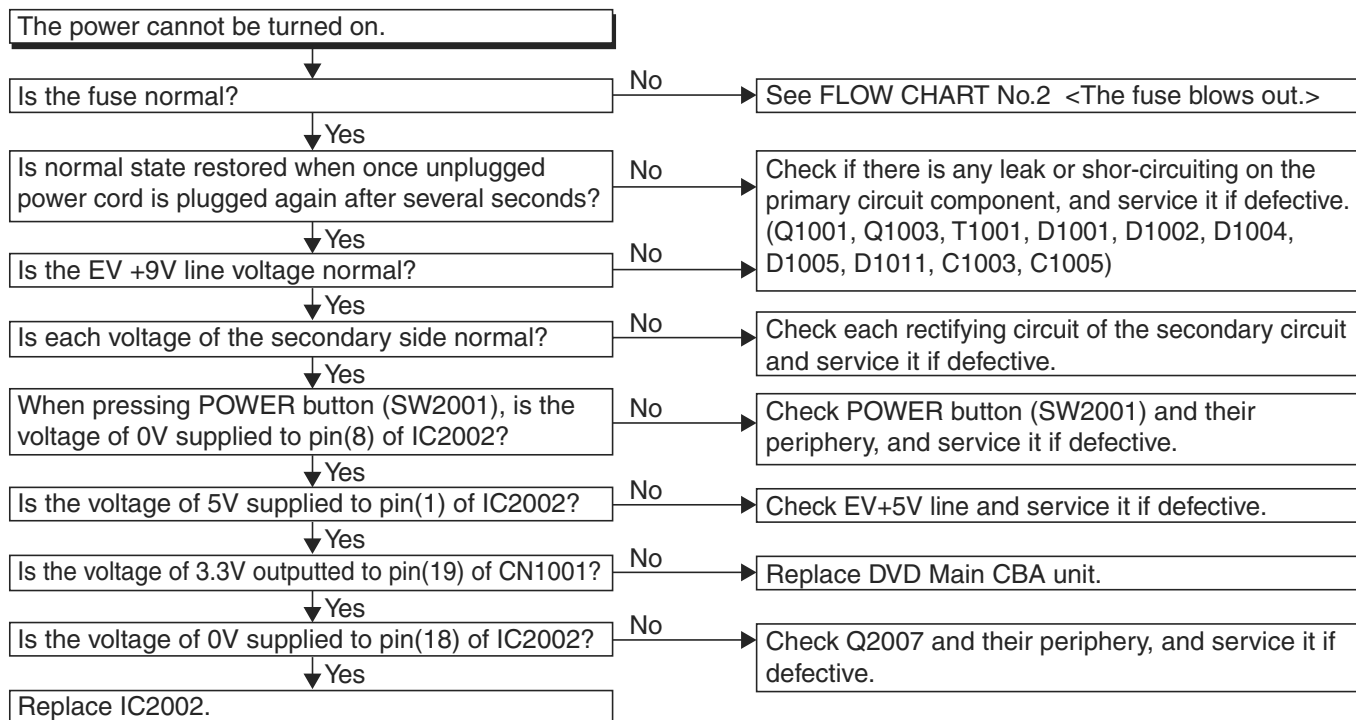

FLOW CHART NO.2

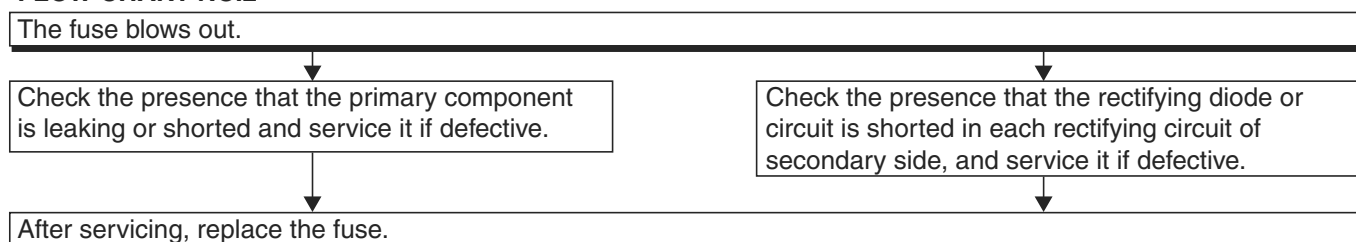

FLOW CHART NO.3

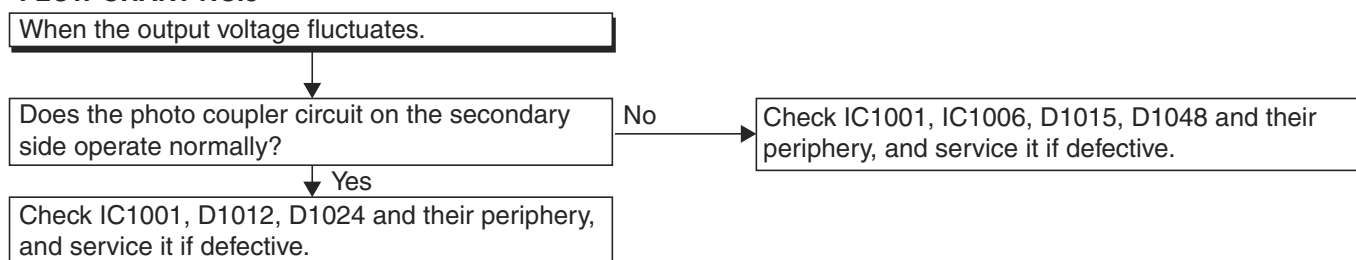

FLOW CHART NO.4

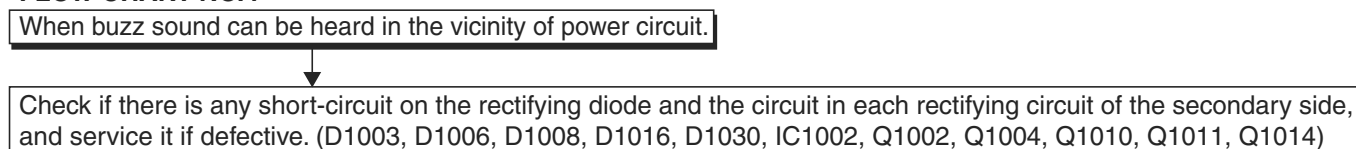

FLOW CHART NO.5

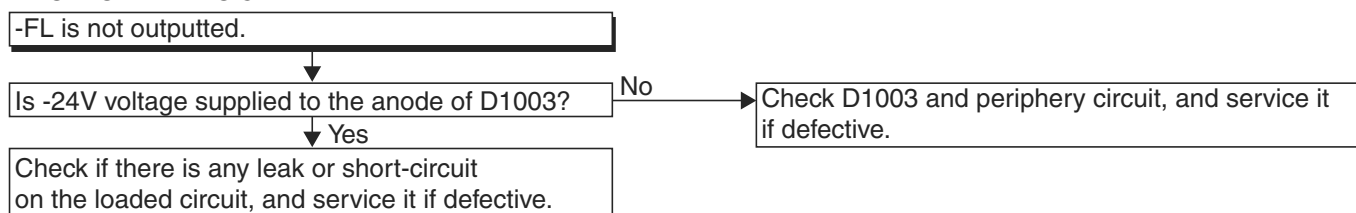

FLOW CHART NO.6

P-ON+12V is not outputted.

Is 14V voltage supplied to the emitter of Q1002?

No → Check D1030, D1048, D1053, C1035, C1048, L1009 and the periphery circuit, and service it if defective.

Yes

Is the voltage of base on Q1002 lower than the voltage of emitter on Q1002 when turning the power on?

No → Check Q1016 and PWRCON line and service it if defective.

Yes

Replace Q1002.

FLOW CHART NO.7

P-ON+5V is not outputted. (EV+9V is outputted normally.)

Is the "H" pulse inputted into the base of Q1004?

No → Check R1068 and D1046, and service it if defective.

Yes

Replace Q1004.

FLOW CHART NO.8

P-ON+3.3V is not outputted. (P-ON+12V is outputted normally.)

Is 3.3V voltage supplied to the collector of Q1011?

No → Check D1008, D1015, C1007, C1038, L1007 and the periphery circuit, and service it if defective.

Yes

Replace Q1011 and R1067.

FLOW CHART NO.9

EV+5V is not outputted. (EV+9V is outputted normally.)

Is the "H" pulse inputted into the base of Q1014?

No → Check Q1014, D1047 and the periphery circuit, and service it if defective.

Yes

Replace Q1014.

FLOW CHART NO.10

EV+1.5V is not outputted.

Is 2.5V voltage supplied to Pin(1) of IC1002?

No → Check D1006, C1014, C1050, L1008 and the periphery circuit, and service it if defective.

Yes

Is 1.25V voltage supplied to Pin(4) of IC1002?

No → Is the "L" pulse outputted into Pin(19) of IC2002?

Yes

Replace IC1002.

Yes → Check the circuit between Pin(19) of IC2002 and Pin(4) of IC1002, and service it if defective.

No → Replace IC2002.

FLOW CHART NO.11

EV+3.3V is not outputted.

Is 3.3V voltage supplied to emitter of Q1010?

No → Check D1008, D1015, C1007, C1038, L1007 and the periphery circuit, and service it if defective.

Yes

Is the "L" pulse inputted to base of Q1012?

No → Is the "L" pulse outputted into Pin(19) of IC2002?

Yes

Check Q1010, Q1012, R1087 and R1088, and service it if defective.

Yes → Check the circuit between Pin(19) of IC2002 and base of Q1012, and service it if defective.

No → Replace IC2002.

FLOW CHART NO.12

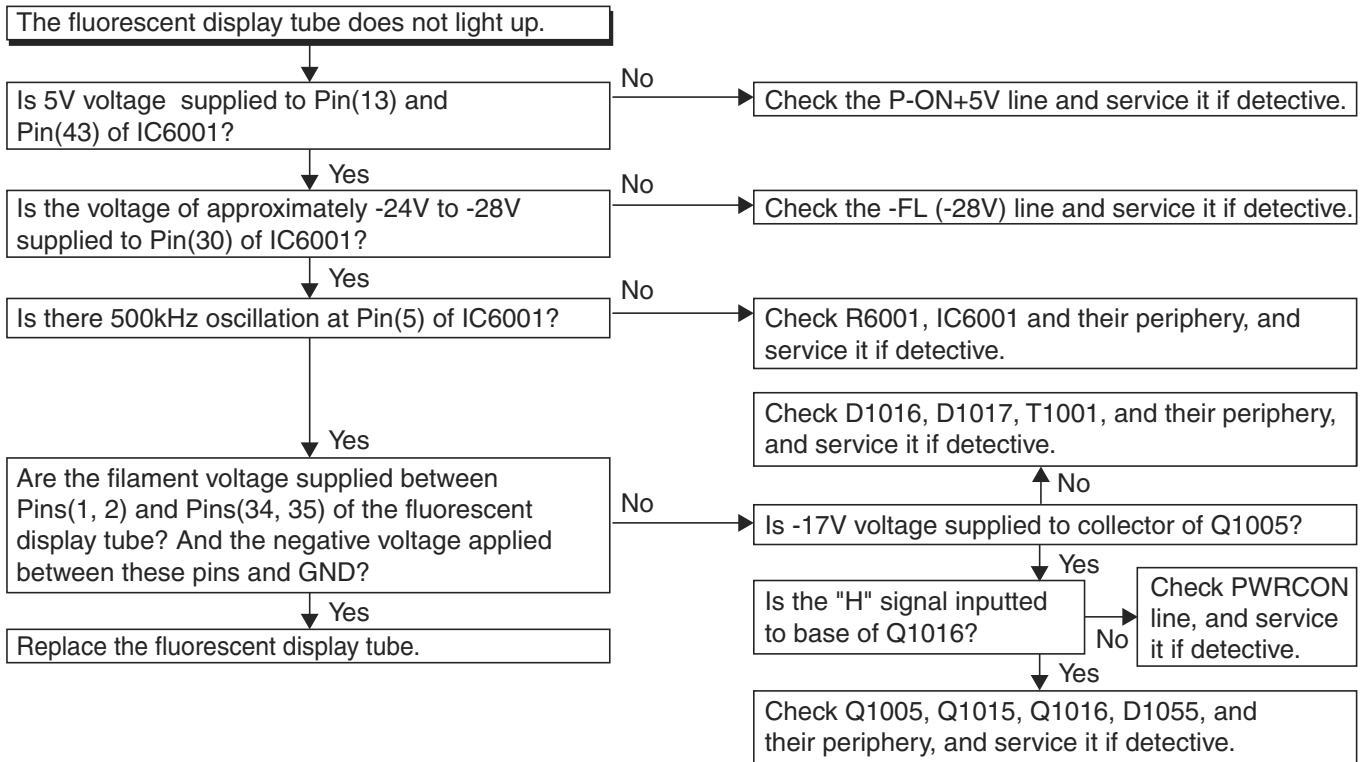

FLOW CHART NO.13

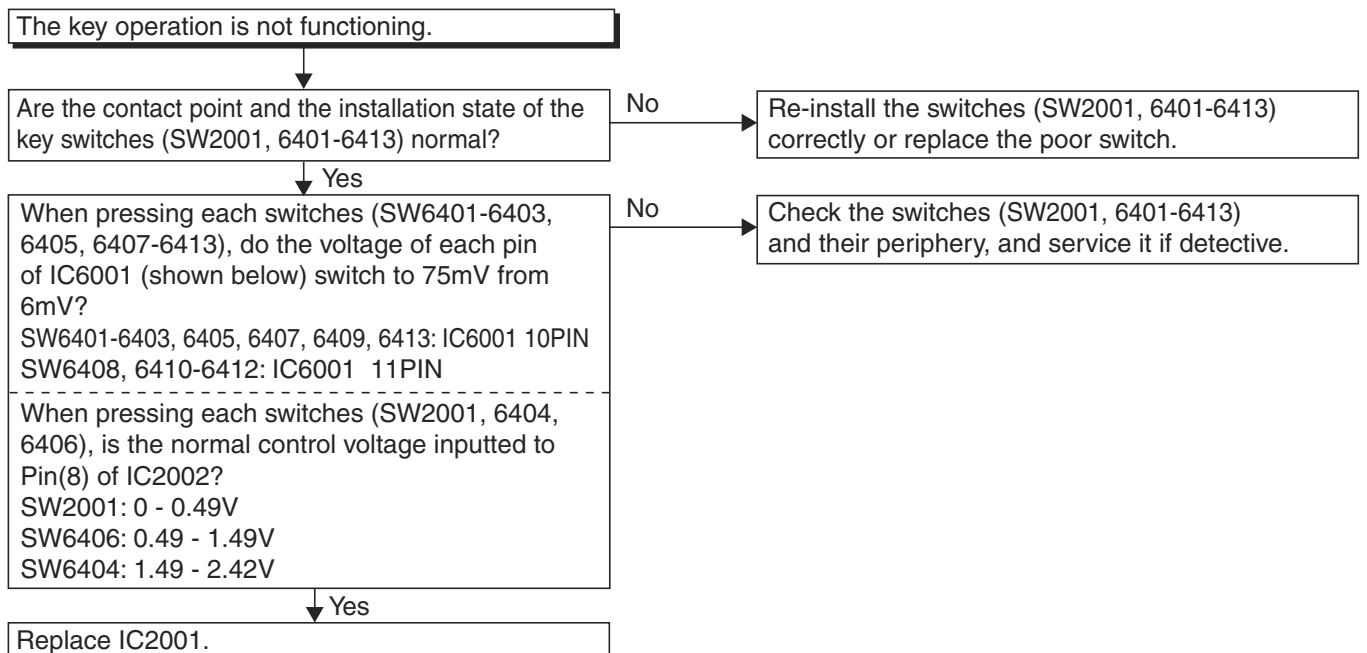

FLOW CHART NO.14

No operation is possible from the remote control unit.

Operation is possible from the DVD, but no operation is possible from the remote control unit.

Yes

Is 5V voltage supplied to the Pin(3) terminal of the infrared remote control receiver (RM2001)?

No

Check EV+5V line and service it if detective.

Yes

Is the "L" pulse sent out Pin(1) terminal of receiver (RM2001) when the infrared remote control is activated?

No

Replace the infrared remote control receiver (RM2001). Or replace the remote control unit.

Yes

Is the "L" pulse outputted to the Pin(20) of IC2002 when the infrared remote control is activated?

No

Replace IC2002.

Yes

Is the "L" pulse supplied to the Pin(22) of CN1001?

No

Check the line between Pin(20) of IC2002 and Pin(22) of CN1001, and service it if detective.

Yes

Replace DVD Main CBA.

FLOW CHART NO.15

The disc tray cannot be opened and closed. (It can be done using the remote control unit.)

Is the normal control voltage inputted to Pin(8) of IC2002?

No

Replace the "OPEN/CLOSE" button (SW6406).

Yes

Refer to "FLOW CHART NO.16" <The disc tray cannot be opened and closed.>

FLOW CHART NO.16

The disc tray cannot be opened and closed.

Replace the DVD Main CBA.

No improvement can be found.

No

Original DVD Main CBA is poor.

Yes

Replace the DVD Mecha.

FLOW CHART NO.17

[No Disc] indicated. (When the focus error occurs.)

Replace the DVD Main CBA.

No improvement can be found.

No

Original DVD Main CBA is poor.

Yes

Replace the DVD Mecha.

FLOW CHART NO.18

[No Disc] indicated. (When the focus servo is not functioning.)

Replace the DVD Main CBA.

No improvement can be found.

No

Original DVD Main CBA is poor.

Yes

Replace the DVD Mecha.

FLOW CHART NO.19

[No Disc] indicated. (When the laser beam does not light up.)

Replace the DVD Main CBA.

No improvement can be found.

No

Original DVD Main CBA is poor.

Yes

Replace the DVD Mecha.

FLOW CHART NO.20

Both functions of picture and sound do not operate normally.

Replace the DVD Main CBA.

No improvement can be found.

No

Original DVD Main CBA is poor.

Yes

Replace the DVD Mecha.

FLOW CHART NO.21

Picture does not appear normally.

Set the disc on the disc tray, and playback.

Are the video signals outputted to each pin of CN1601 on the AV CBA?

CN1601	1PIN	S-Y
CN1601	9PIN	S-C
CN1601	7PIN	G
CN1601	5PIN	B/Cb
CN1601	3PIN	R/Cr

No → Replace the DVD Main CBA or DVD Mecha.

Yes

Are the video signals shown above inputted into each pin of IC6101?

IC6101	6PIN	S-Y
IC6101	2PIN	S-C
IC6101	16PIN	G
IC6101	12PIN	B/Cb
IC6101	14PIN	R/Cr

No → Check the line between each pin of CN1601 and each pin of IC6101 on the AV CBA, and service it if defective.

CN1601	1PIN	→	IC6101	6PIN	S-Y
CN1601	9PIN	→	IC6101	2PIN	S-C
CN1601	7PIN	→	IC6101	16PIN	G
CN1601	5PIN	→	IC6101	12PIN	B/Cb
CN1601	3PIN	→	IC6101	14PIN	R/Cr

Yes

Are the video signals outputted to each pin of IC6101?

IC6101	31PIN	CVBS
IC6101	28PIN	S-Y
IC6101	33PIN	S-C
IC6101	19PIN	G
IC6101	25PIN	B/Cb
IC6101	22PIN	R/Cr

No → Is 5V voltage applied to the pin(1, 34) of IC6101?

Yes → Replace IC6101.

No → Check P-ON+5V line and service it if defective.

Yes

Are the video signals outputted to the specific output terminal?

Are the luminance signals outputted to the S-OUT terminal (JK1401)?

Are the chroma signals outputted to the S-OUT terminal (JK1401)?

Are the component video signals(RGB) outputted to the VIDEO OUT terminal (JK6101)?

Are the component video signals(Y/Cb/Cr) outputted to the VIDEO OUT terminal (JK6102)?

Are the composite video signals outputted to the VIDEO OUT terminal (JK6101, JK6103)?

No → Check the periphery of JK1401 from Pin (28) of IC6101 and service it if defective.

No → Check the periphery of JK1401 from Pin (33) of IC6101 and service it if defective.

No → Check the periphery of JK6101 from Pins (19, 22, 25) of IC6101 and service it if defective.

No → Check the periphery of JK6102 from Pin (22, 25, 28) of IC6101 and service it if defective.

No → Check the periphery of JK6101 and JK6103 from Pin(31) of IC6101 and service it if defective.

FLOW CHART NO.22

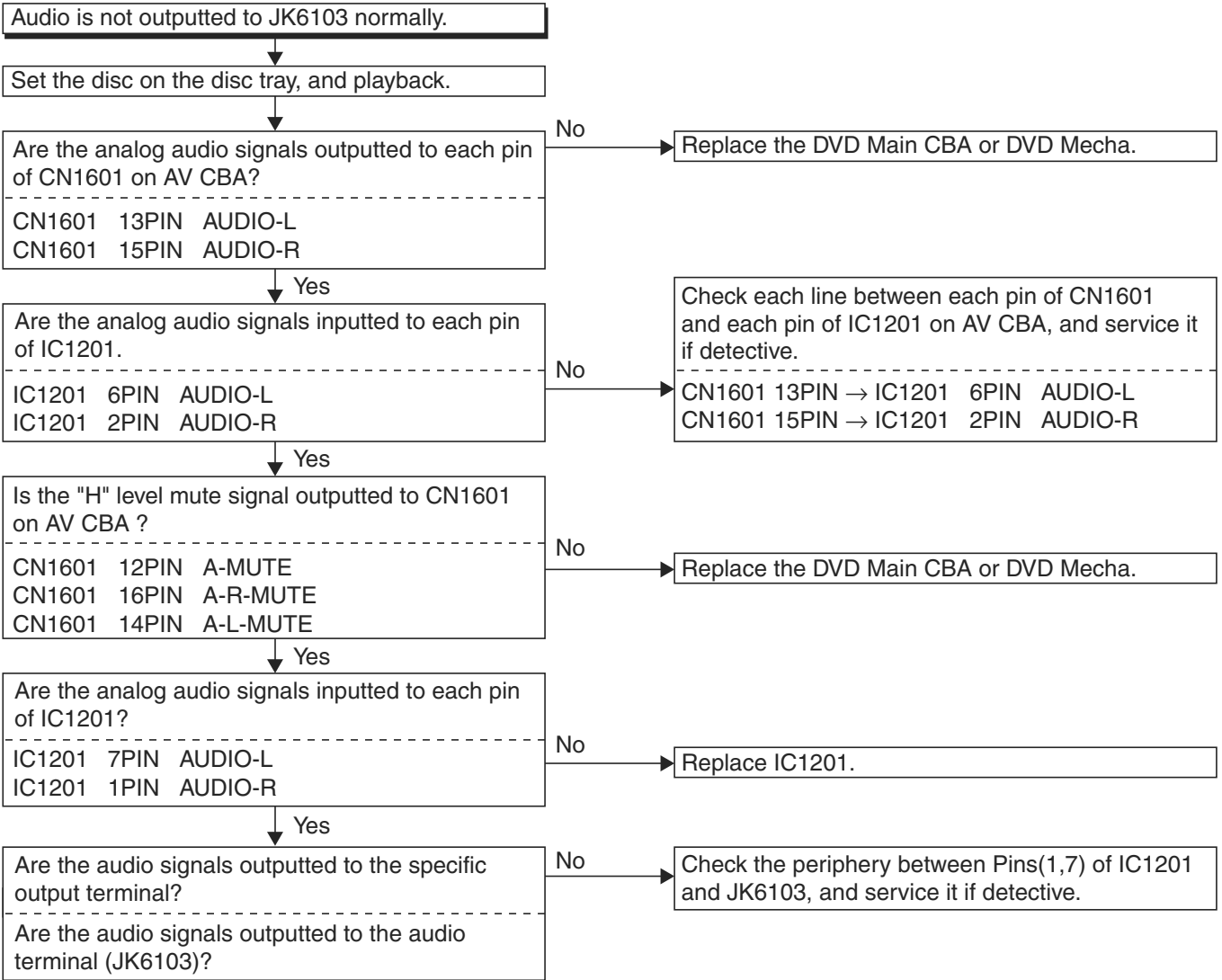

FLOW CHART NO.23 (FOR DV6400/N1B, DV6400/N1S)

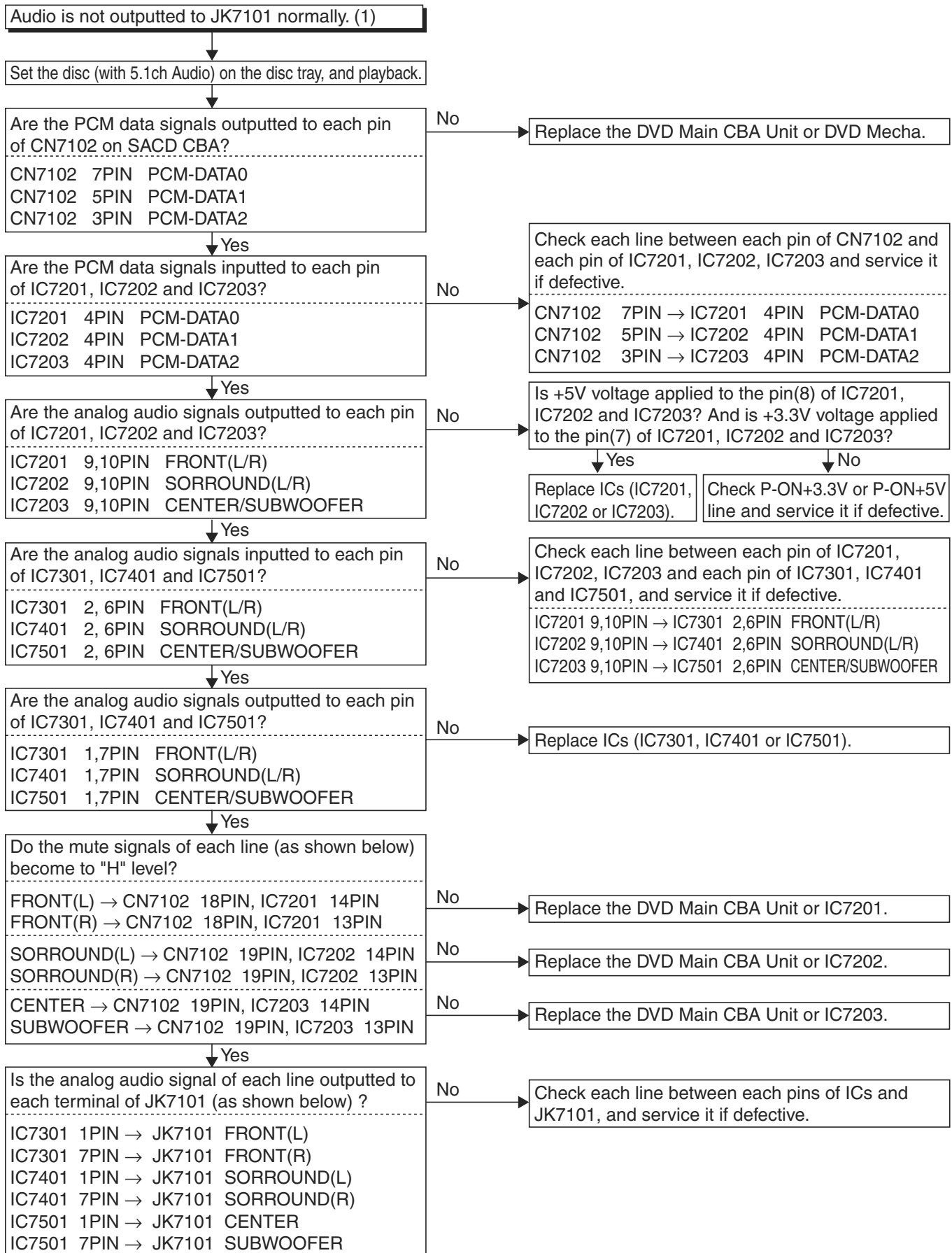

FLOW CHART NO.24 (FOR DV6400/N1B, DV6400/N1S)

Audio is not outputted to JK7101 normally. (2)

Set the disc (with Super Audio) on the disc tray, and playback.

Are the PCM data signals inputted to each pin of CN7102 on SACD CBA?

 CN7102 7PIN PCM-DATA0
 CN7102 5PIN PCM-DATA1
 CN7102 3PIN PCM-DATA2
 CN7102 1PIN PCM-DATA3

No → Replace the DVD Main CBA Unit or DVD Mecha.

Yes
 Are the PCM data signals inputted to each pin of IC7251?

 IC7251 170PIN PCM-DATA0
 IC7251 171PIN PCM-DATA1
 IC7251 172PIN PCM-DATA2
 IC7251 173PIN PCM-DATA3

No → Check each line between each pin of CN7102 on SACD CBA and each pin of IC7251, and service it if defective.

 CN7102 7PIN → IC7251 170PIN PCM-DATA0
 CN7102 5PIN → IC7251 171PIN PCM-DATA1
 CN7102 3PIN → IC7251 172PIN PCM-DATA2
 CN7102 1PIN → IC7251 173PIN PCM-DATA2

Yes
 Are the DSD data signals outputted to each pin of IC7251?

 IC7251 64PIN DSD-L
 IC7251 66PIN DSD-R
 IC7251 74PIN DSD-LS
 IC7251 76PIN DSD-RS
 IC7251 69PIN DSD-C
 IC7251 71PIN DSD-SW

No → Is the power supply voltage applied to each pin of IC7251?

 IC7251 5,35,54,83,99,121,124,125,153PIN: P-ON+2.5V
 IC7251 17,45,90,110,135,146,163PIN: P-ON+3.3V

Yes → Replace IC7251.
 No → Check P-ON+2.5V or P-ON+3.3V line, and service it if defective.

Yes
 Are the DSD data signals inputted to each pin of IC7201, IC7202 and IC7203?

 IC7201 1PIN DSD-L
 IC7201 2PIN DSD-R
 IC7202 1PIN DSD-LS
 IC7202 2PIN DSD-RS
 IC7203 1PIN DSD-C
 IC7203 2PIN DSD-SW

No → Check each line between each pin of IC7251 and each pin of IC7201, IC7202, IC7203, and service it if defective.

 IC7251 64PIN → IC7201 1PIN DSD-L
 IC7251 66PIN → IC7201 2PIN DSD-R
 IC7251 74PIN → IC7202 1PIN DSD-LS
 IC7251 76PIN → IC7202 2PIN DSD-RS
 IC7251 69PIN → IC7203 1PIN DSD-C
 IC7251 71PIN → IC7203 2PIN DSD-SW

Yes
 Are the analog audio signals outputted to each pin of IC7201, IC7202 and IC7203?

 IC7201 9,10PIN FRONT(L/R)
 IC7202 9,10PIN SORROUND(L/R)
 IC7203 9,10PIN CENTER/SUBWOOFER

No → Is +5V voltage applied to the pin(8) of IC7201, IC7202 and IC7203? And is +3.3V voltage applied to the pin(7) of IC7201, IC7202 and IC7203?

Yes → Replace ICs (IC7201, IC7202 or IC7203).
 No → Check P-ON+3.3V or P-ON+5V line and service it if defective.

Yes
 Are the analog audio signals inputted to each pin of IC7301, IC7401 and IC7501?

 IC7301 2, 6PIN FRONT(L/R)
 IC7401 2, 6PIN SORROUND(L/R)
 IC7501 2, 6PIN CENTER/SUBWOOFER

No → Check each line between each pin of IC7201, IC7202, IC7203 and each pin of IC7301, IC7401 and IC7501, and service it if defective.

 IC7201 9,10PIN → IC7301 2,6PIN FRONT(L/R)
 IC7202 9,10PIN → IC7401 2,6PIN SORROUND(L/R)
 IC7203 9,10PIN → IC7501 2,6PIN CENTER/SUBWOOFER

√ (continued to "A" on next page)

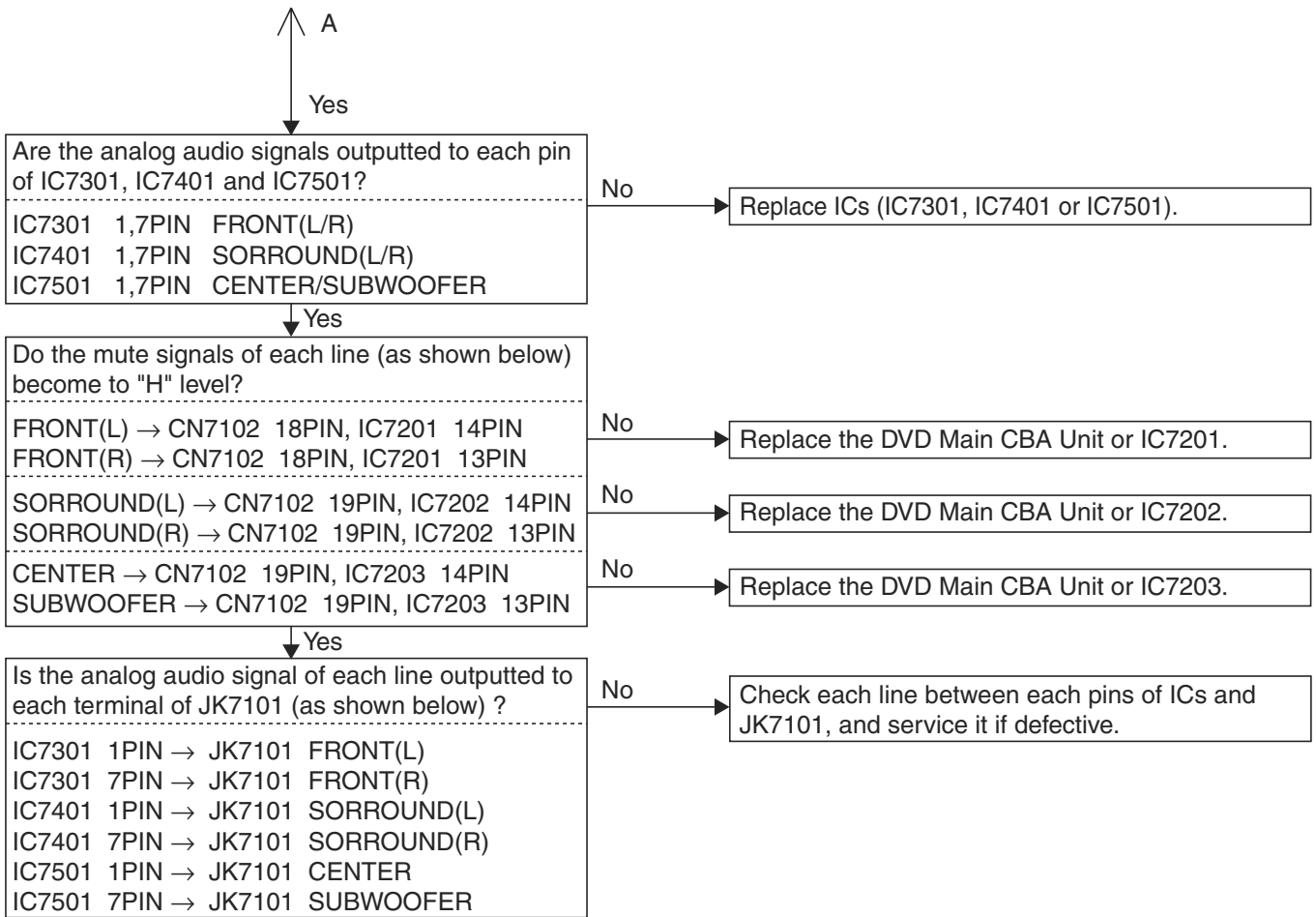

BLOCK DIAGRAMS

System Control/Servo Block Diagram (DV4400/N1B, DV4400/N1S)

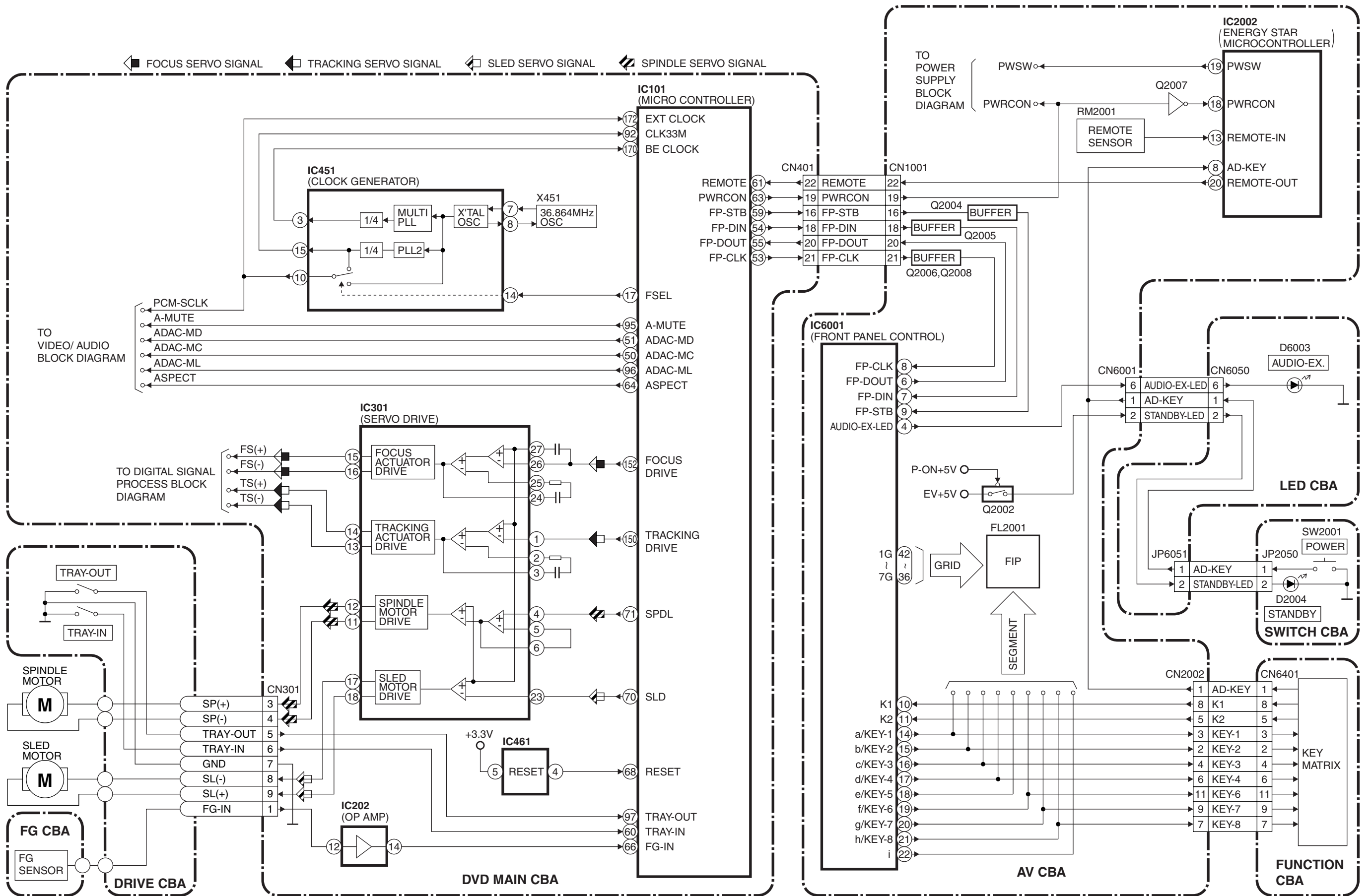

Digital Signal Process Block Diagram (DV4400/N1B, DV4400/N1S)

DATA(VIDEO/AUDIO) SIGNAL
 VIDEO SIGNAL
 DATA(AUDIO) SIGNAL
 FOCUS SERVO SIGNAL
 TRACKING SERVO SIGNAL

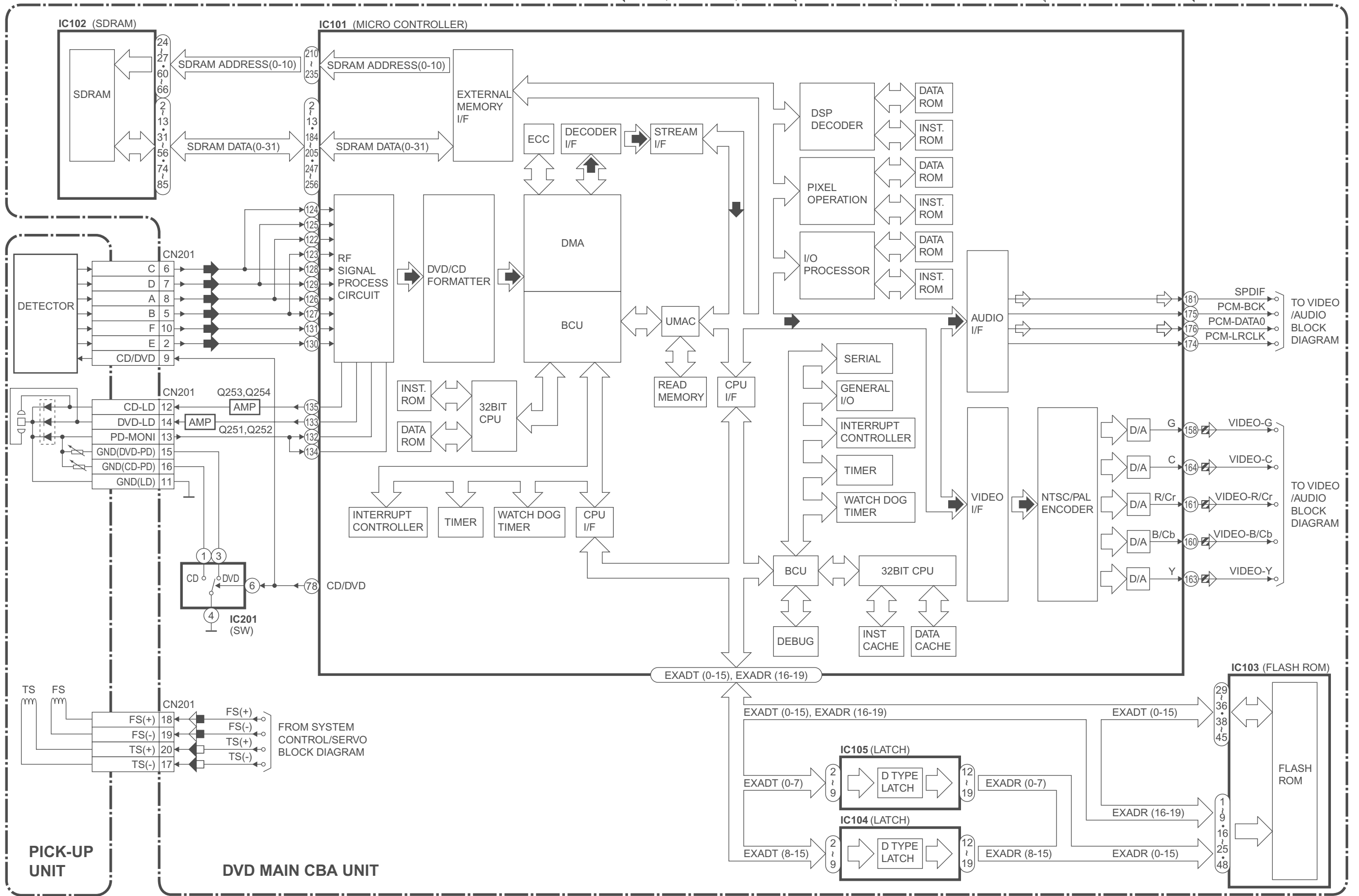

Video / Audio Block Diagram (DV4400/N1B, DV4400/N1S)

VIDEO SIGNAL
 DATA(AUDIO) SIGNAL
 AUDIO SIGNAL

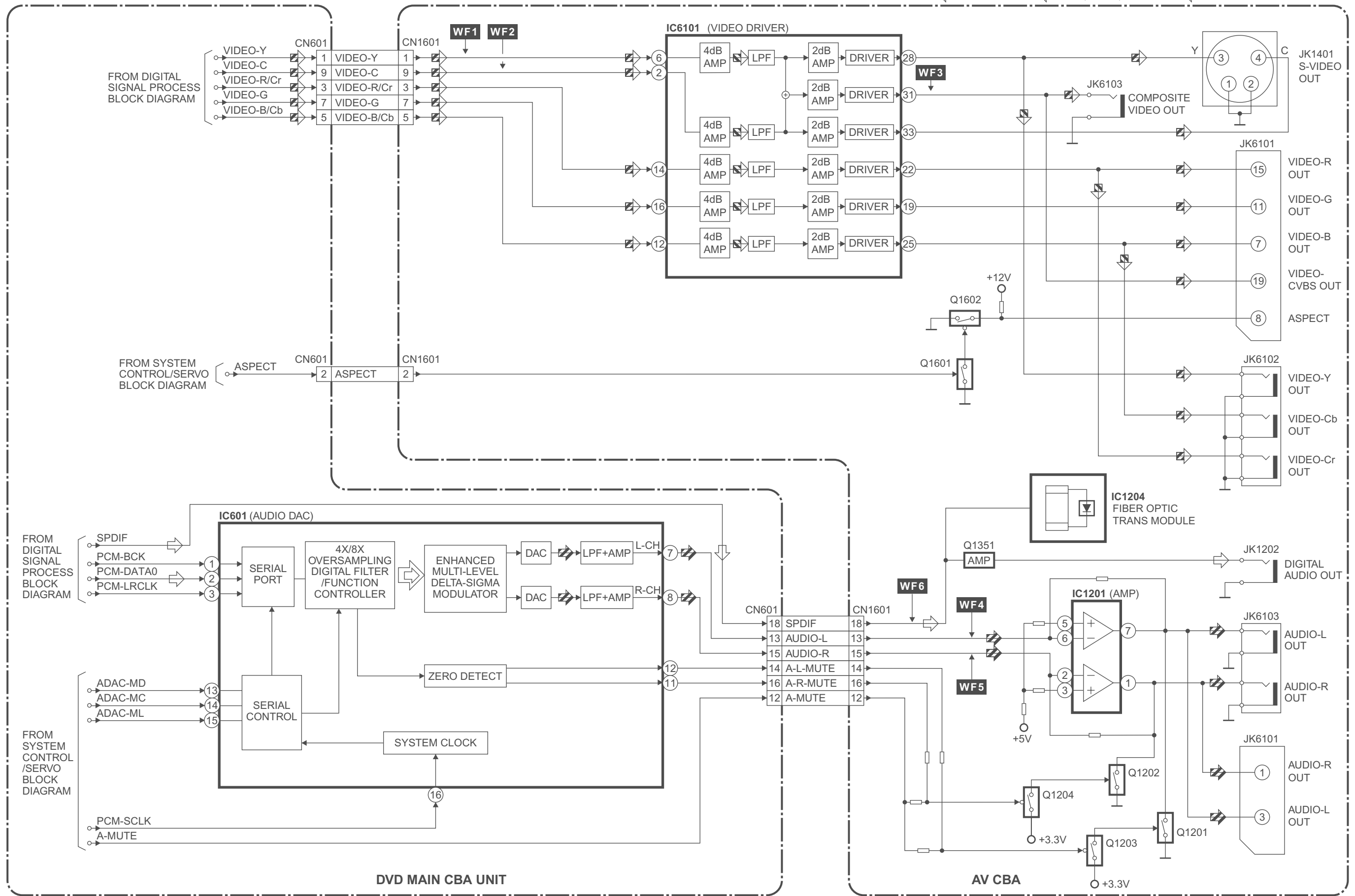

Power Supply Block Diagram (DV4400/N1B, DV4400/N1S)

CAUTION !

Fixed voltage (or Auto voltage selectable) power supply circuit is used in this unit.
If Main Fuse (F1001) is blown, check to see that all components in the power supply circuit are not defective before you connect the AC plug to the AC power supply.
Otherwise it may cause some components in the power supply circuit to fail.

CAUTION

FOR CONTINUED PROTECTION AGAINST FIRE HAZARD,
REPLACE ONLY WITH THE SAME TYPE FUSE.

NOTE :

The voltage for parts in hot circuit is measured using hot GND as a common terminal.

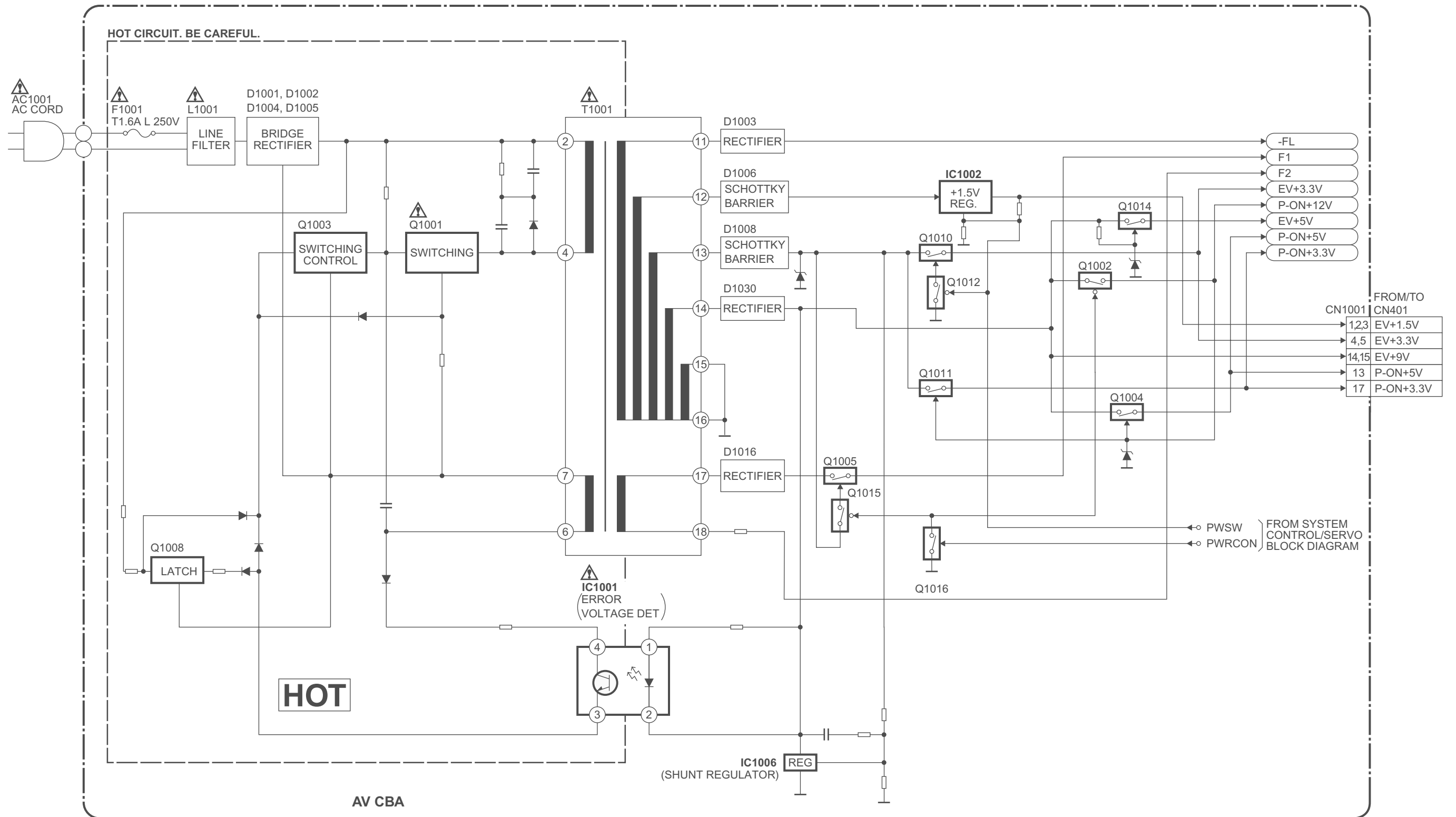

BLOCK DIAGRAMS

System Control/Servo Block Diagram (DV6400/N1B, DV6400/N1S)

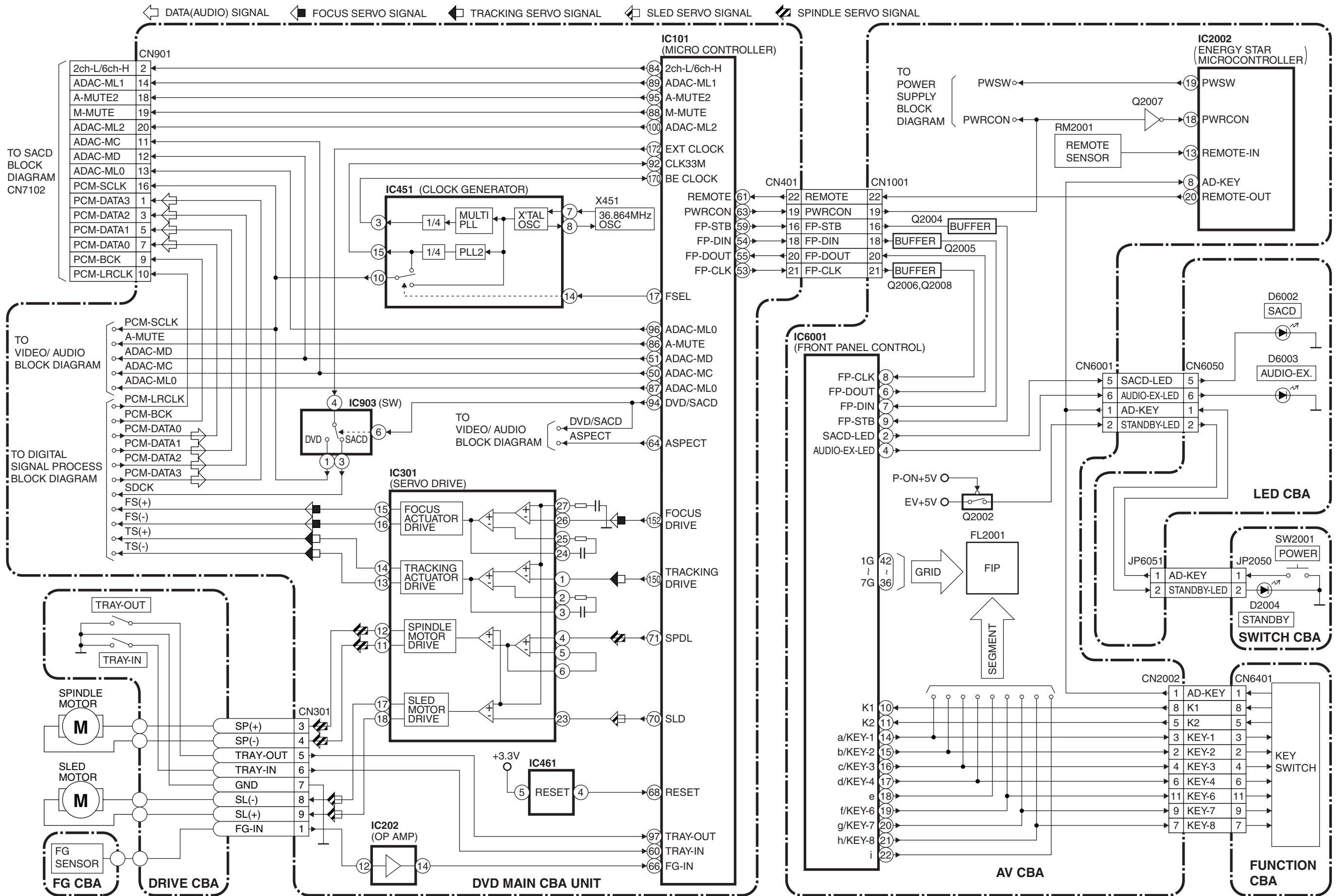

Digital Signal Process Block Diagram (DV6400/N1B, DV6400/N1S)

DATA(AUDIO) SIGNAL
 VIDEO SIGNAL
 DATA(VIDEO) SIGNAL
 DATA(AUDIO) SIGNAL
 FOCUS SERVO SIGNAL
 TRACKING SERVO SIGNAL

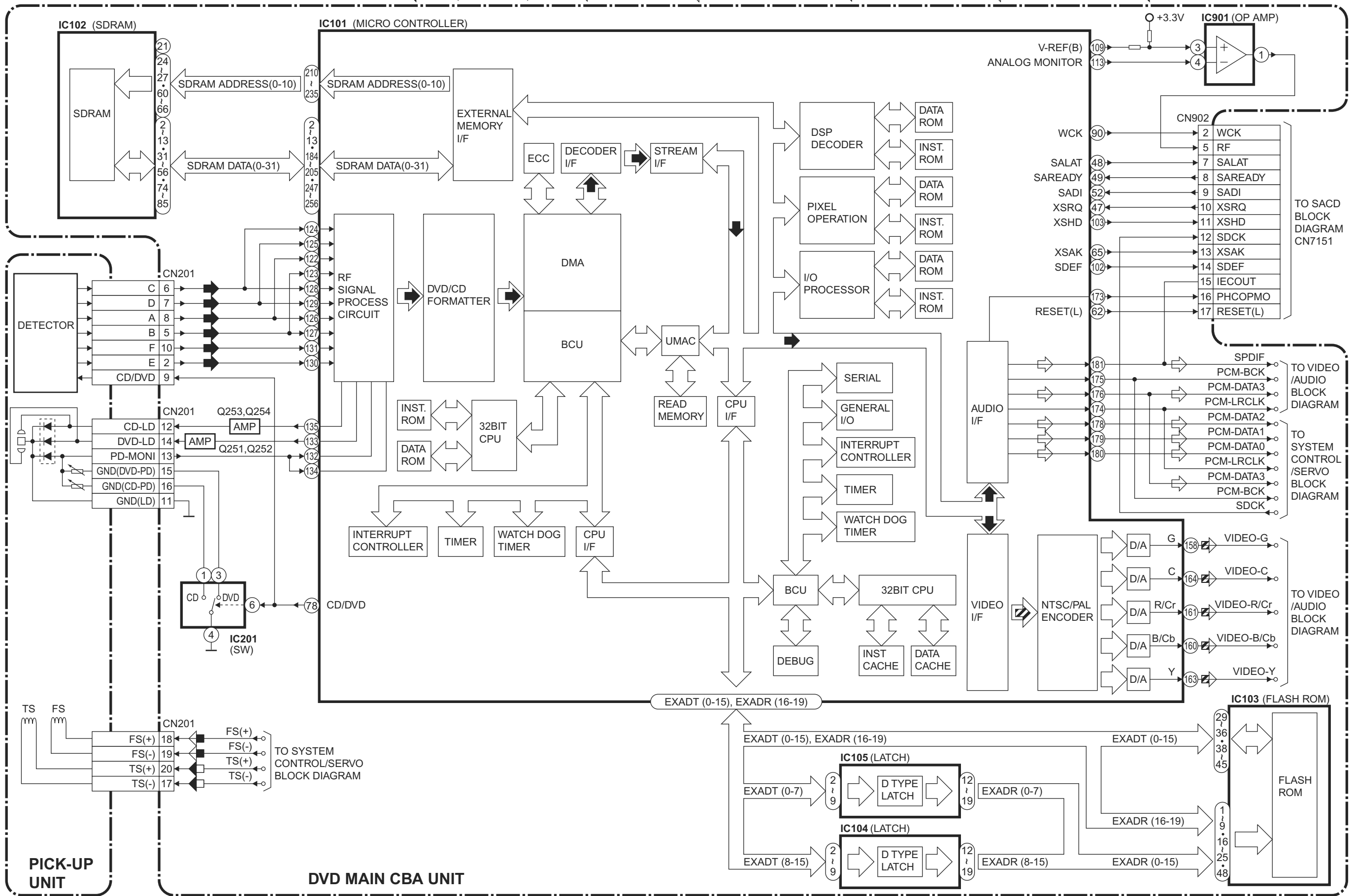

Video / Audio Block Diagram (DV6400/N1B, DV6400/N1S)

VIDEO SIGNAL DATA(AUDIO) SIGNAL AUDIO SIGNAL

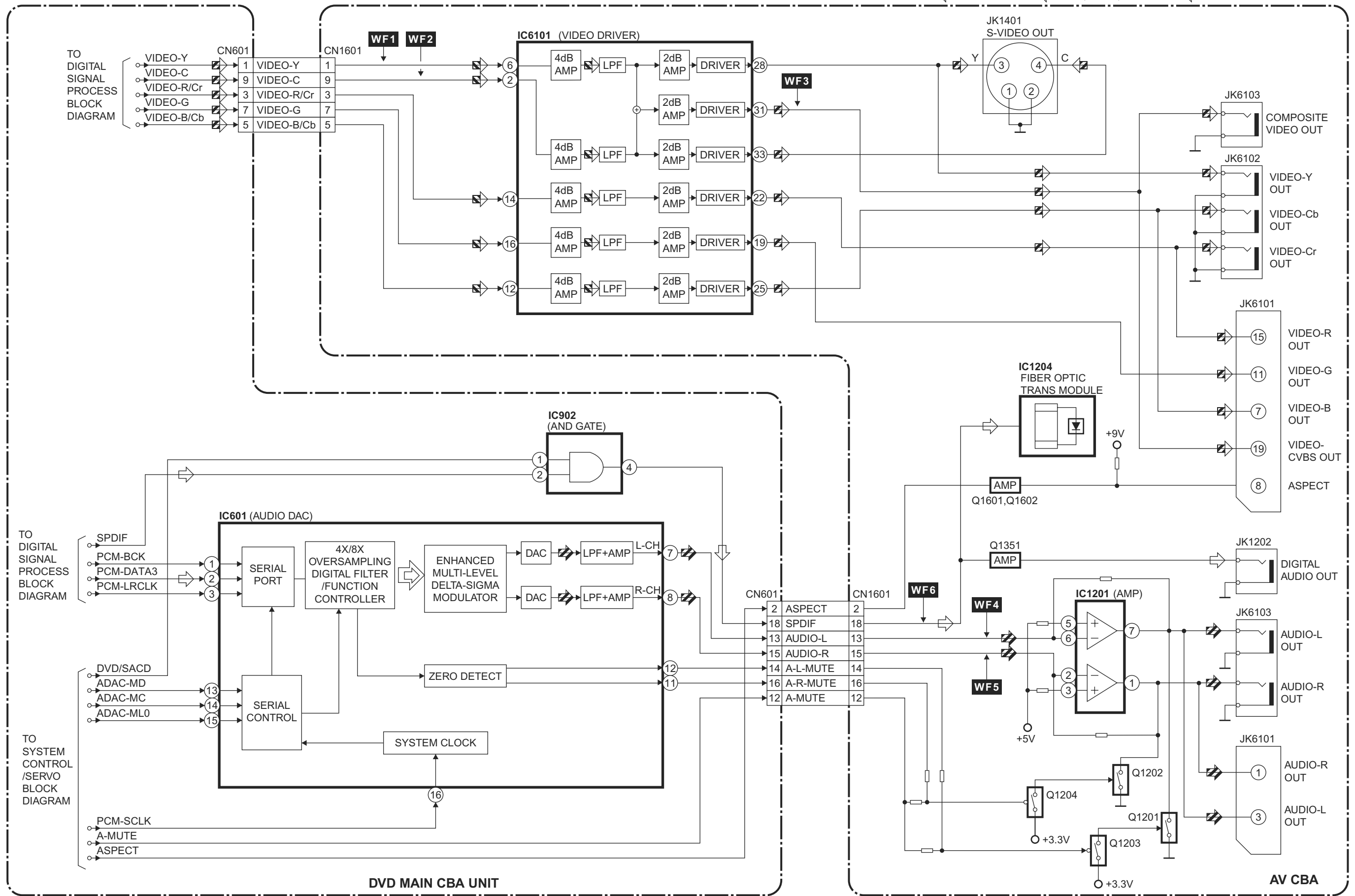

SACD Block Diagram (DV6400/N1B, DV6400/N1S)

DATA(AUDIO) SIGNAL AUDIO SIGNAL

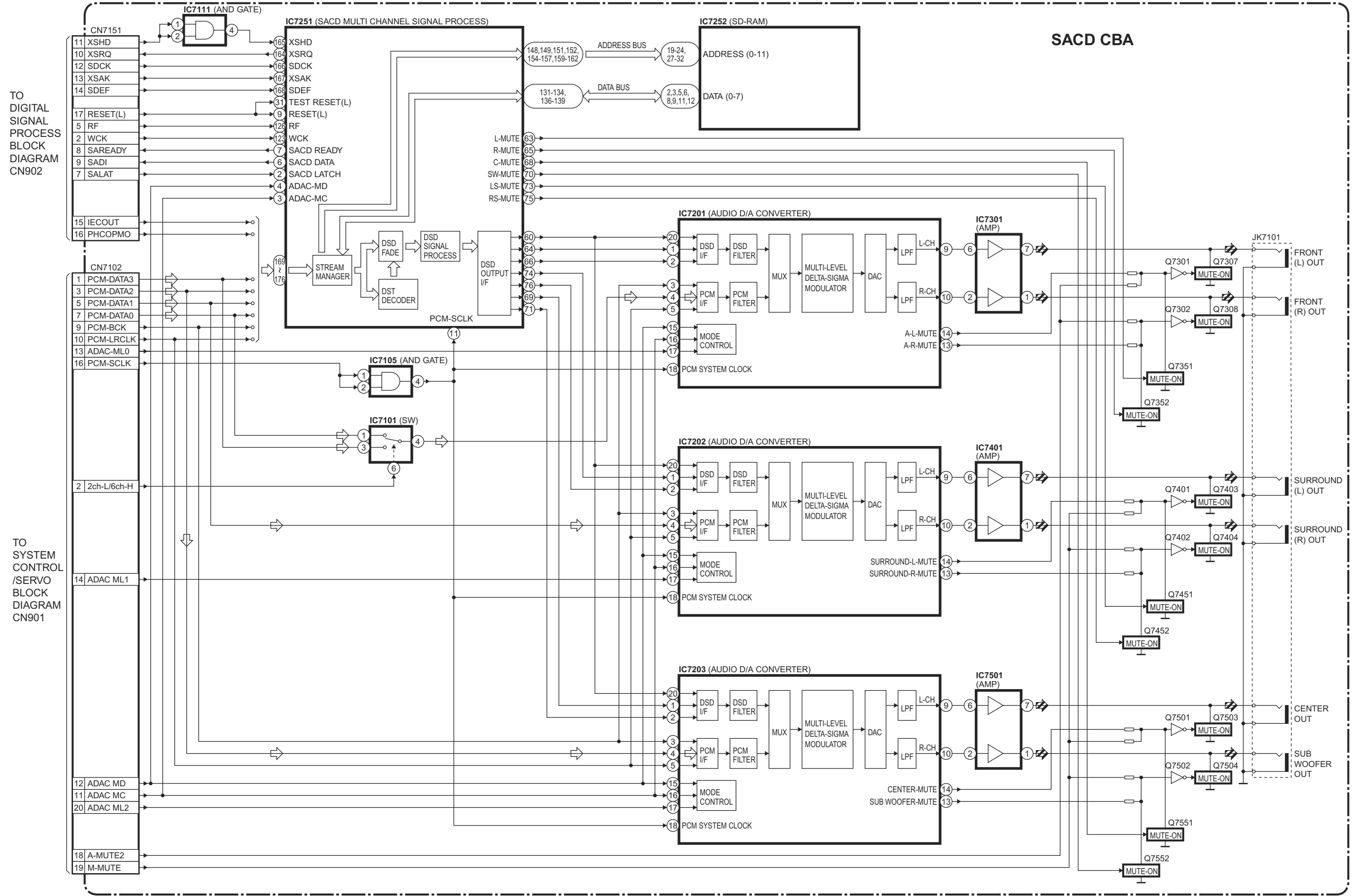

Power Supply Block Diagram (DV6400/N1B, DV6400/N1S)

CAUTION !

Fixed voltage (or Auto voltage selectable) power supply circuit is used in this unit.
If Main Fuse (F1001) is blown, check to see that all components in the power supply circuit are not defective before you connect the AC plug to the AC power supply.
Otherwise it may cause some components in the power supply circuit to fail.

CAUTION

FOR CONTINUED PROTECTION AGAINST FIRE HAZARD,
REPLACE ONLY WITH THE SAME TYPE FUSE.

NOTE :

The voltage for parts in hot circuit is measured using hot GND as a common terminal.

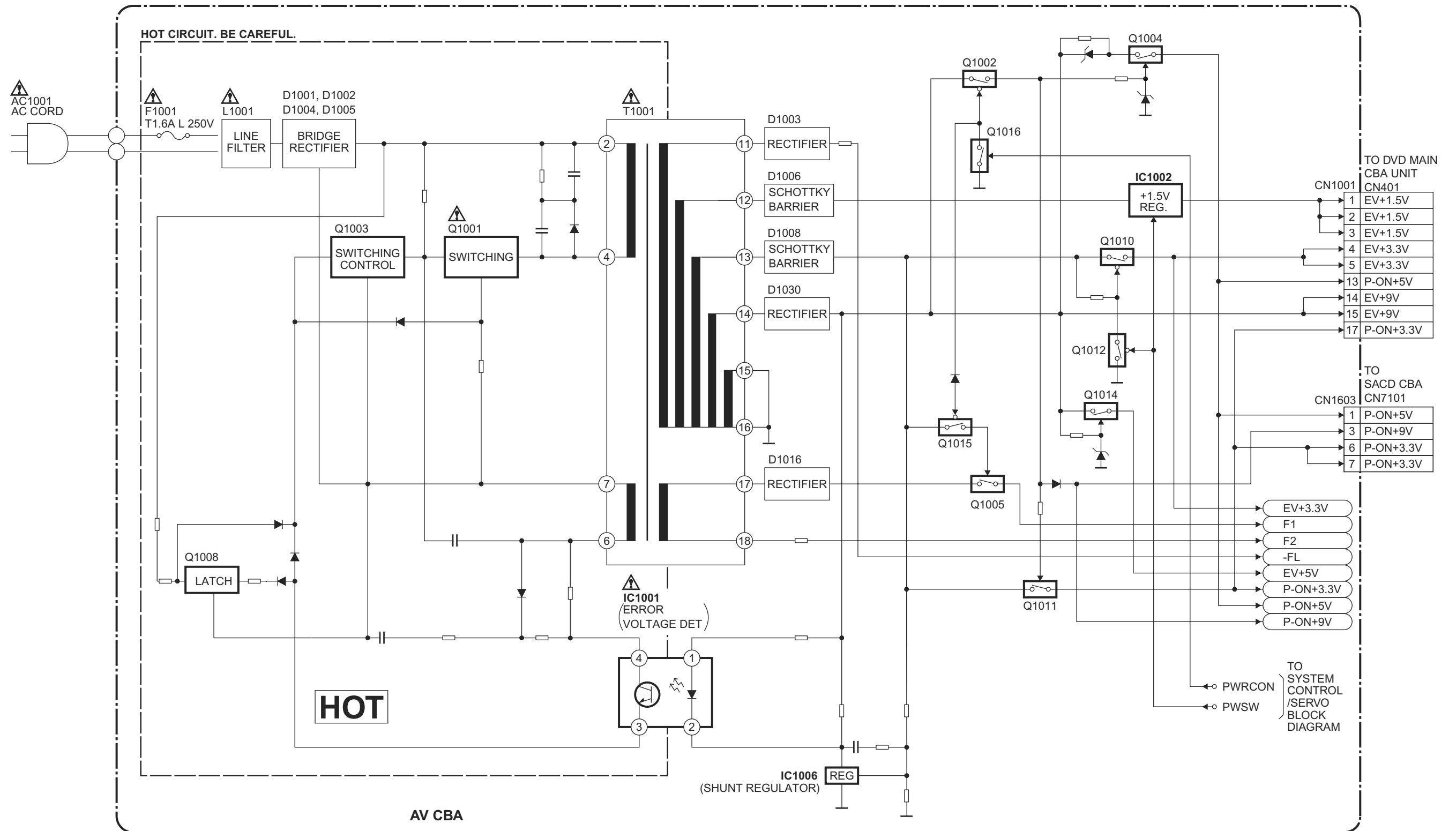

SCHEMATIC DIAGRAMS / CBA'S AND TEST POINTS

Standard Notes

WARNING

Many electrical and mechanical parts in this chassis have special characteristics. These characteristics often pass unnoticed and the protection afforded by them cannot necessarily be obtained by using replacement components rated for higher voltage, wattage, etc. Replacement parts that have these special safety characteristics are identified in this manual and its supplements; electrical components having such features are identified by the mark " ⚠ " in the schematic diagram and the parts list. Before replacing any of these components, read the parts list in this manual carefully. The use of substitute replacement parts that do not have the same safety characteristics as specified in the parts list may create shock, fire, or other hazards.

Notes:

1. Do not use the part number shown on these drawings for ordering. The correct part number is shown in the parts list, and may be slightly different or amended since these drawings were prepared.
2. All resistance values are indicated in ohms ($K=10^3$, $M=10^6$).
3. Resistor wattages are 1/4W or 1/6W unless otherwise specified.
4. All capacitance values are indicated in μF ($P=10^{-6} \mu F$).
5. All voltages are DC voltages unless otherwise specified.
6. Electrical parts such as capacitors, connectors, diodes, IC's, transistors, resistors, switches, and fuses are identified by four digits. The first two digits are not shown for each component. In each block of the diagram, there is a note such as shown below to indicate these abbreviated two digits.

LIST OF CAUTION, NOTES, AND SYMBOLS USED IN THE SCHEMATIC DIAGRAMS ON THE FOLLOWING PAGES:

1. CAUTION:

FOR CONTINUED PROTECTION AGAINST FIRE HAZARD, REPLACE ONLY WITH THE SAME TYPE FUSE.

2. CAUTION:

Fixed Voltage (or Auto voltage selectable) power supply circuit is used in this unit.
If Main Fuse (F1001) is blown, first check to see that all components in the power supply circuit are not defective before you connect the AC plug to the AC power supply. Otherwise it may cause some components in the power supply circuit to fail.

3. Note:

- (1) Do not use the part number shown on the drawings for ordering. The correct part number is shown in the parts list, and may be slightly different or amended since the drawings were prepared.
- (2) To maintain original function and reliability of repaired units, use only original replacement parts which are listed with their part numbers in the parts list section of the service manual.

4. Wire Connectors

- (1) Prefix symbol "CN" means "connector" (can disconnect and reconnect).
- (2) Prefix symbol "CL" means "wire-solder holes of the PCB" (wire is soldered directly).

5. Voltage indications for PLAY modes on the schematics are as shown below:

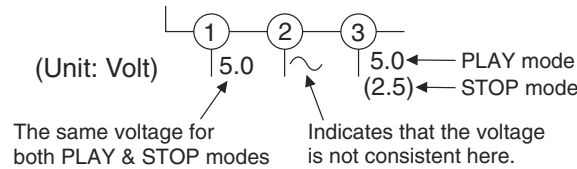

6. How to read converged lines

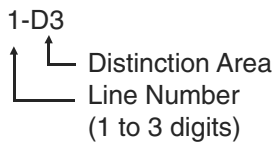

Examples:

- 1. "1-D3" means that line number "1" goes to area "D3".
- 2. "1-B1" means that line number "1" goes to area "B1".

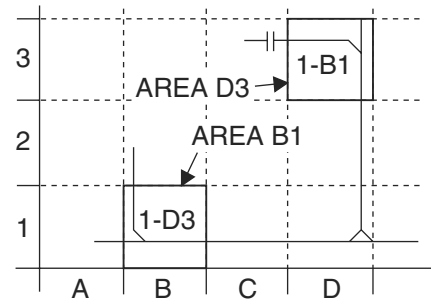

7. Test Point Information

- ⊙ : Indicates a test point with a jumper wire across a hole in the PCB.
- : Used to indicate a test point with a component lead on foil side.
- ⊘ : Used to indicate a test point with no test pin.
- : Used to indicate a test point with a test pin.

DVD Main 1/3 Schematic Diagram (DV4400/N1B, DV4400/N1S)

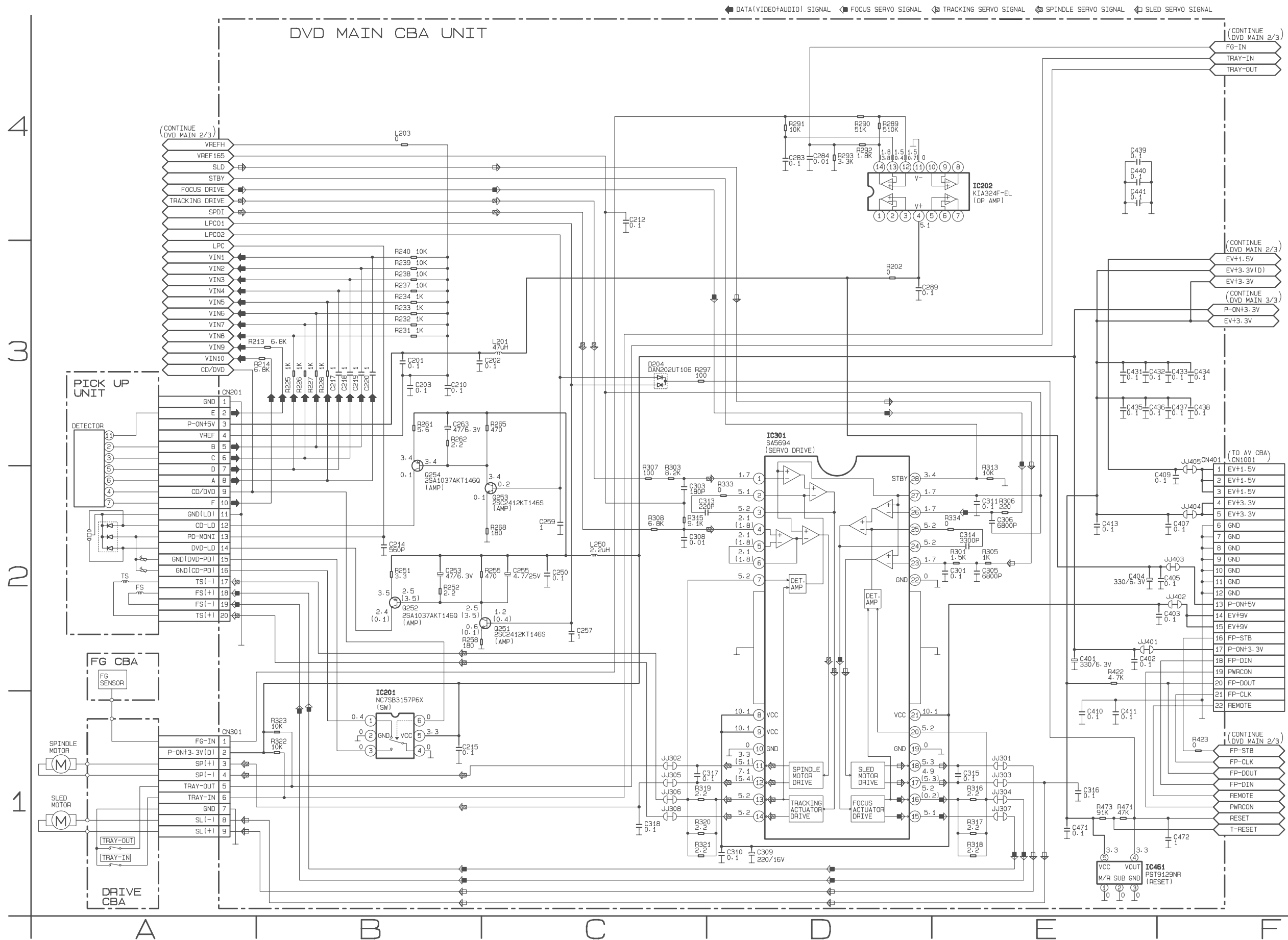

DVD Main 2/3 Schematic Diagram (DV4400/N1B, DV4400/N1S)

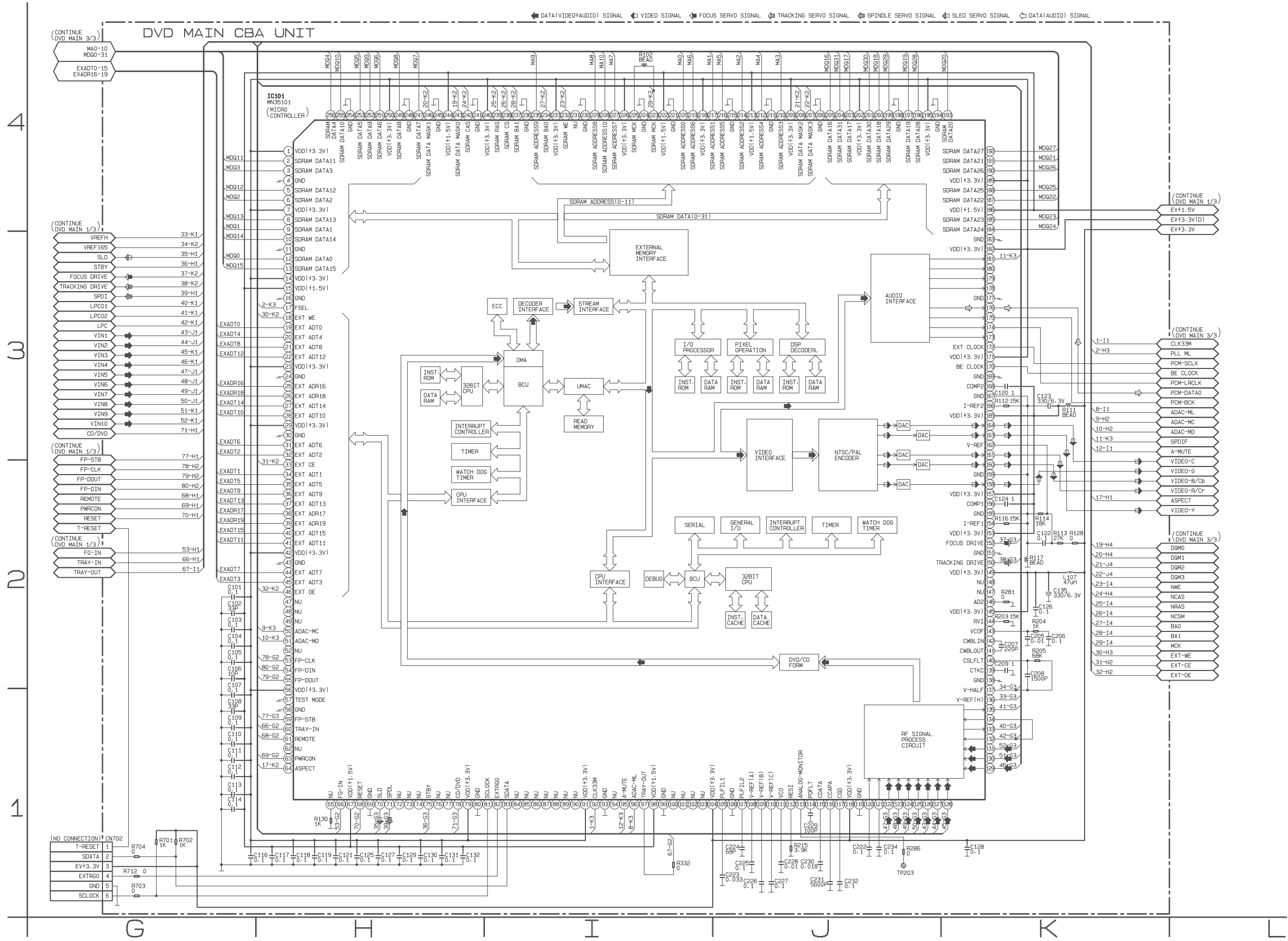

IC101 VOLTAGE CHART (DV4400/N1B, DV4400/N1S)

PIN.NO	PLAY	STOP	PIN.NO	PLAY	STOP	PIN.NO	PLAY	STOP	PIN.NO	PLAY	STOP	PIN.NO	PLAY	STOP	PIN.NO	PLAY	STOP	PIN.NO	PLAY	STOP	PIN.NO	PLAY	STOP
1	3.3	3.3	33	2.2	2.9	65	0.1	0.1	97	3.4	3.4	129	2.0	2.0	161	0.5	0.5	193	~	~	225	1.9	1.9
2	~	~	34	~	~	66	1.2	2.5	98	1.6	1.6	130	2.2	2.2	162	1.4	1.4	194	0	0	226	3.3	3.3
3	~	~	35	~	~	67	1.6	1.6	99	0	0	131	2.3	2.3	163	1.4	1.4	195	3.3	3.3	227	~	~
4	0	0	36	~	~	68	3.4	3.4	100	----	----	132	0.4	0.1	164	0.9	0.9	196	~	~	228	~	~
5	~	~	37	~	~	69	0	0	101	----	----	133	1.2	0.4	165	3.3	3.3	197	~	~	229	~	~
6	~	~	38	0.3	0.5	70	1.7	1.7	102	----	----	134	0.4	0.1	166	1.5	1.5	198	0	0	230	0	0
7	3.3	3.3	39	0.1	0.1	71	2.4	1.7	103	----	----	135	0.2	0.2	167	0	0	199	~	~	231	~	~
8	~	~	40	~	~	72	----	----	104	3.3	3.3	136	2.3	2.3	168	2.1	2.1	200	~	~	232	3.3	3.3
9	~	~	41	~	~	73	----	----	105	0.9	0.9	137	1.7	1.7	169	0	0	201	~	~	233	3.3	3.3
10	~	~	42	3.3	3.3	74	----	----	106	0	0	138	0	0	170	0.8	0.8	202	3.3	3.3	234	1.6	1.6
11	0	0	43	0	0	75	3.4	3.4	107	0.8	0.8	139	1.7	1.7	171	3.3	3.3	203	~	~	235	~	~
12	~	~	44	~	~	76	----	----	108	1.6	1.6	140	1.7	1.7	172	1.6	1.6	204	~	~	236	0	0
13	~	~	45	~	~	77	----	----	109	2.1	2.1	141	1.7	1.7	173	0.2	0.2	205	~	~	237	1.7	1.7
14	3.3	3.3	46	2.0	2.6	78	0.1	0.1	110	2.6	2.6	142	1.7	1.7	174	1.8	1.8	206	0	0	238	3.0	3.0
15	1.5	1.5	47	----	----	79	3.3	3.3	111	2.0	2.0	143	0.5	0.5	175	1.7	1.7	207	2.4	3.5	239	3.3	3.3
16	0	0	48	----	----	80	0	0	112	0.7	0.9	144	1.6	1.6	176	1.4	0.1	208	2.4	2.1	240	3.3	3.3
17	3.4	3.4	49	----	----	81	3.3	3.3	113	2.0	2.0	145	3.3	3.3	177	0	0	209	3.3	3.3	241	0	0
18	3.4	3.4	50	3.4	3.4	82	3.3	3.3	114	1.8	1.8	146	0	0	178	0.9	0.1	210	~	~	242	3.2	3.2
19	~	~	51	3.4	3.4	83	3.4	3.4	115	1.4	1.4	147	----	----	179	1.4	0.1	211	0	0	243	2.4	2.1
20	~	~	52	----	----	84	----	----	116	0.3	0.3	148	----	----	180	1.4	0.1	212	~	~	244	1.5	1.5
21	~	~	53	3.4	3.4	85	----	----	117	1.6	1.6	149	3.3	3.3	181	1.7	1.7	213	1.5	1.5	245	0	0
22	~	~	54	3.4	3.4	86	----	----	118	3.3	3.3	150	1.7	1.7	182	3.3	3.3	214	~	~	246	2.4	2.1
23	3.3	3.3	55	3.3	3.3	87	----	----	119	0	0	151	0	0	183	0	0	215	0	0	247	~	~
24	0	0	56	3.3	3.3	88	----	----	120	1.9	1.9	152	1.7	1.7	184	~	~	216	~	~	248	0	0
25	0.4	0.4	57	0	0	89	----	----	121	1.9	1.9	153	3.3	3.3	185	~	~	217	~	~	249	~	~
26	0.9	0.6	58	0	0	90	----	----	122	2.4	2.4	154	1.4	1.4	186	1.5	1.5	218	3.3	3.3	250	3.3	3.3
27	~	~	59	3.3	3.3	91	3.3	3.3	123	2.4	2.4	155	0	0	187	~	~	219	~	~	251	~	~
28	~	~	60	3.4	3.4	92	1.7	1.5	124	2.4	2.4	156	2.2	2.2	188	~	~	220	~	~	252	~	~
29	3.3	3.3	61	3.1	3.1	93	0	0	125	2.4	2.4	157	3.3	3.3	189	3.3	3.3	221	0	0	253	~	~
30	0	0	62	----	----	94	----	----	126	2.0	2.0	158	0.7	0.7	190	~	~	222	1.5	1.5	254	0	0
31	~	~	63	3.4	3.4	95	3.4	0.1	127	2.0	2.0	159	0	0	191	~	~	223	1.9	1.9	255	~	~
32	~	~	64	0.8	0.8	96	3.4	3.4	128	2.0	2.0	160	0.5	0.5	192	~	~	224	0	0	256	~	~

DVD Main 3/3 Schematic Diagram (DV4400/N1B, DV4400/N1S)

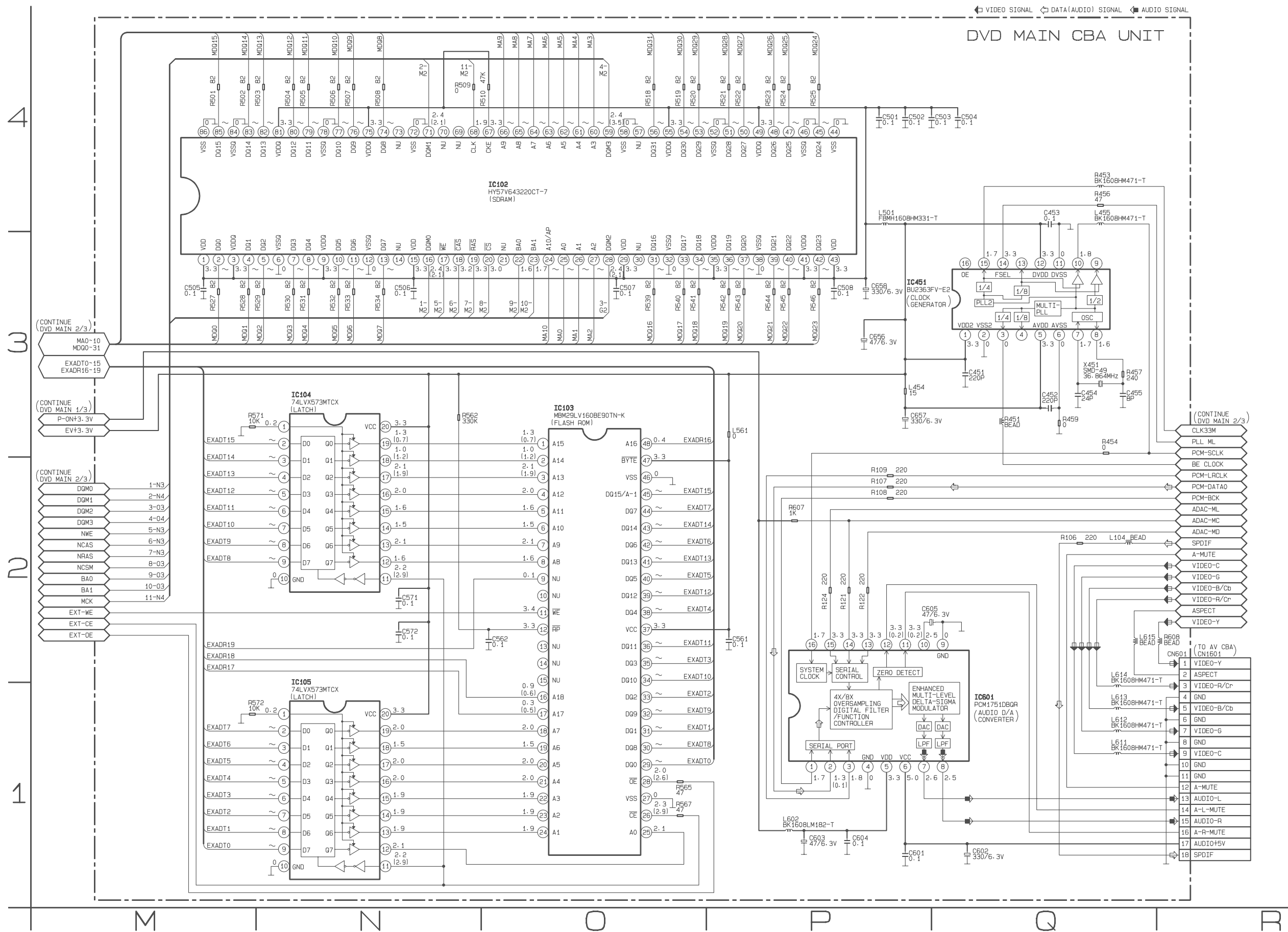

AV 1/3 Schematic Diagram (DV4400/N1B, DV4400/N1S)

CAUTION !

Fixed voltage (or Auto voltage selectable) power supply circuit is used in this unit.
If Main Fuse (F1001) is blown, check to see that all components in the power supply circuit are not defective before you connect the AC plug to the AC power supply.
Otherwise it may cause some components in the power supply circuit to fail.

CAUTION

FOR CONTINUED PROTECTION AGAINST FIRE HAZARD,
REPLACE ONLY WITH THE SAME TYPE FUSE.

NOTE :

THE VOLTAGE FOR PARTS IN HOT CIRCUIT IS MEASURED USING
HOT GND AS A COMMON TERMINAL.

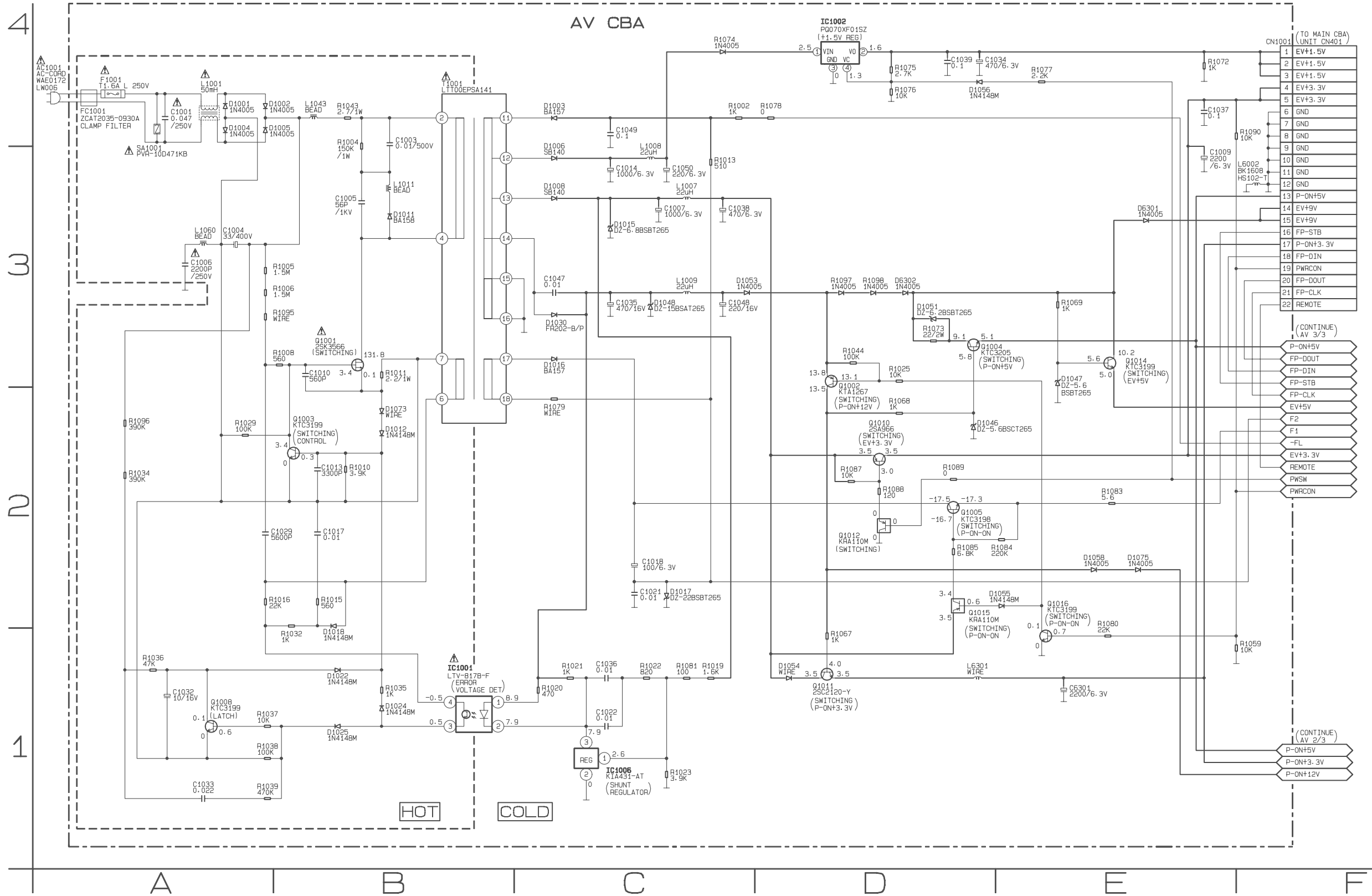

AV 2/3 Schematic Diagram (DV4400/N1B, DV4400/N1S)

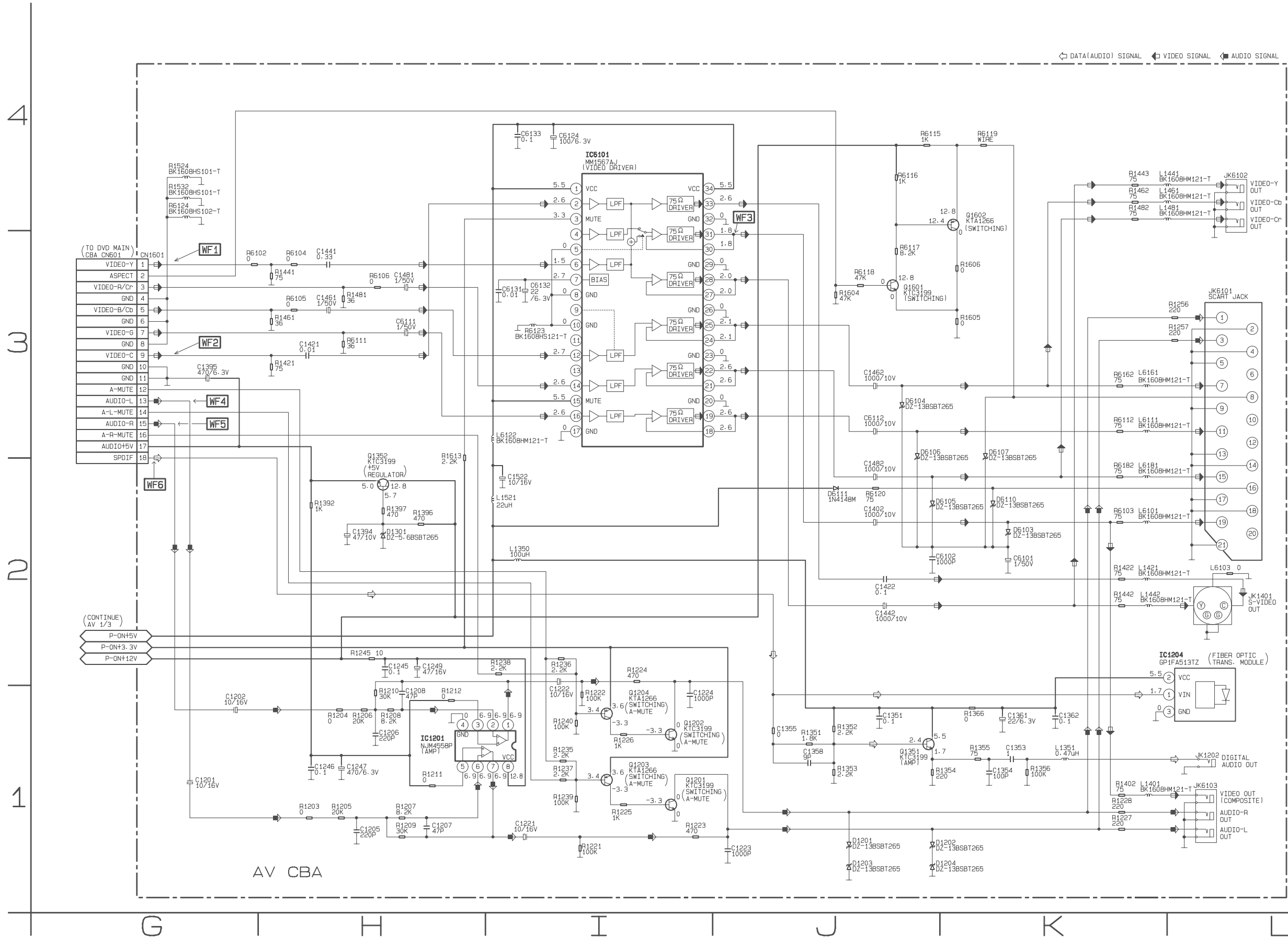

AV 3/3, Function, Switch & LED Schematic Diagram (DV4400/N1B, DV4400/N1S)

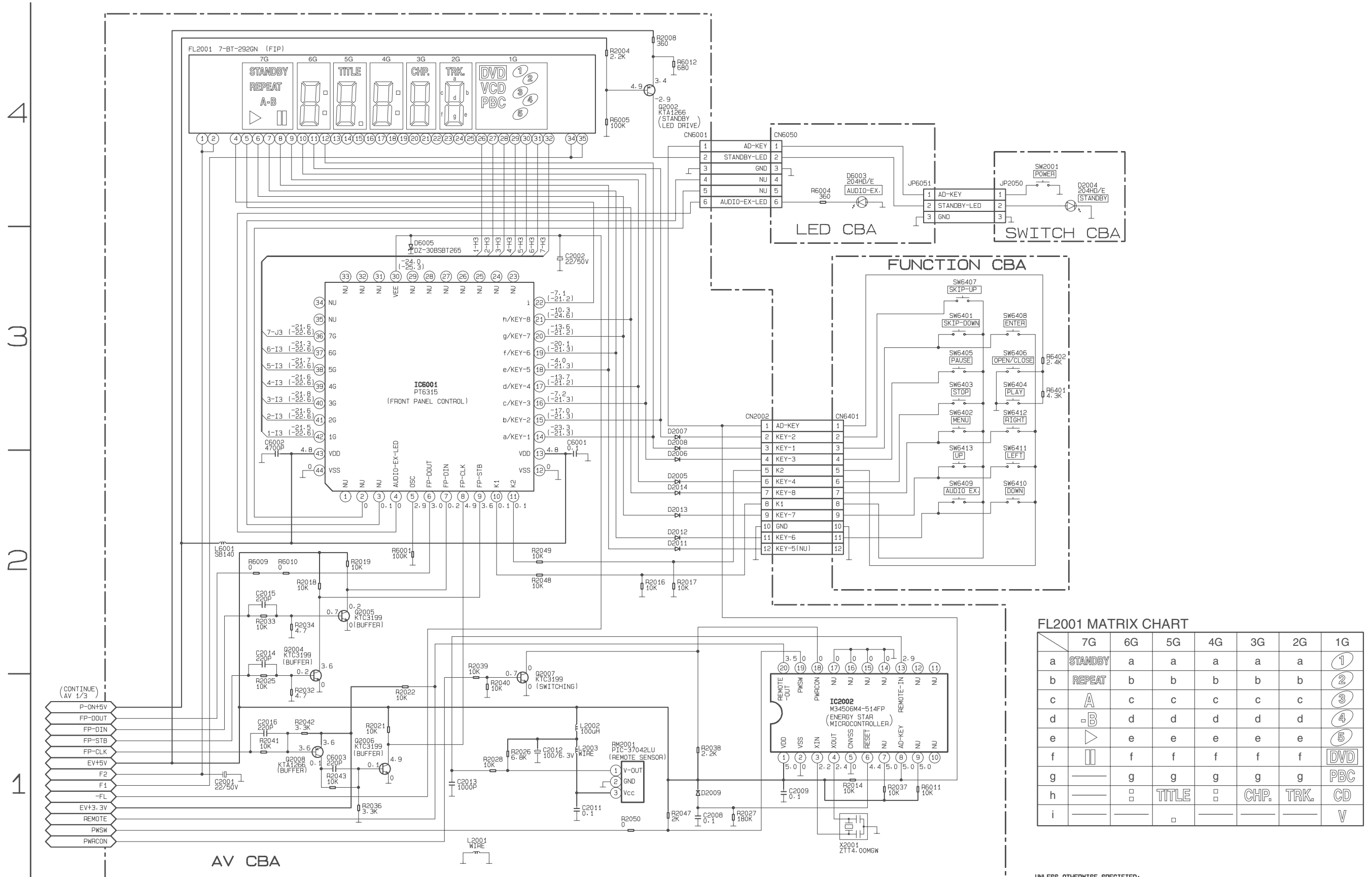

FL2001 MATRIX CHART

	7G	6G	5G	4G	3G	2G	1G
a	STANDBY	a	a	a	a	a	①
b	REPEAT	b	b	b	b	b	②
c	A	c	c	c	c	c	③
d	B	d	d	d	d	d	④
e	▶	e	e	e	e	e	⑤
f	⏸	f	f	f	f	f	DVD
g	—	g	g	g	g	g	PBC
h	□	□	TITLE	□	CHP.	TRK.	CD
i	—	□	—	—	—	—	V

UNLESS OTHERWISE SPECIFIED, SWITCHES ARE KSM0614B.

DVD Main 1/3 Schematic Diagram (DV6400/N1B, DV6400/N1S)

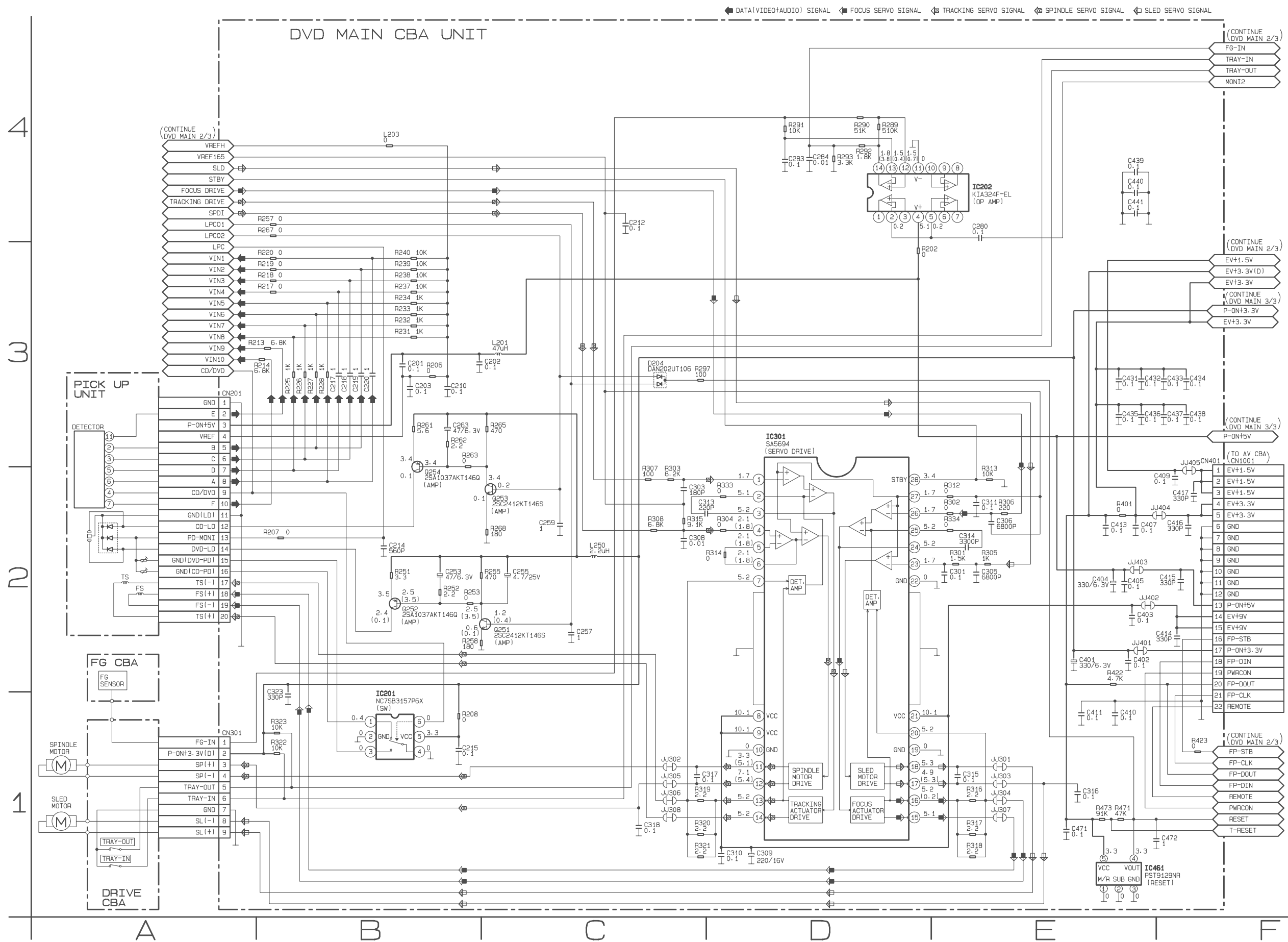

DVD Main 2/3 Schematic Diagram (DV6400/N1B, DV6400/N1S)

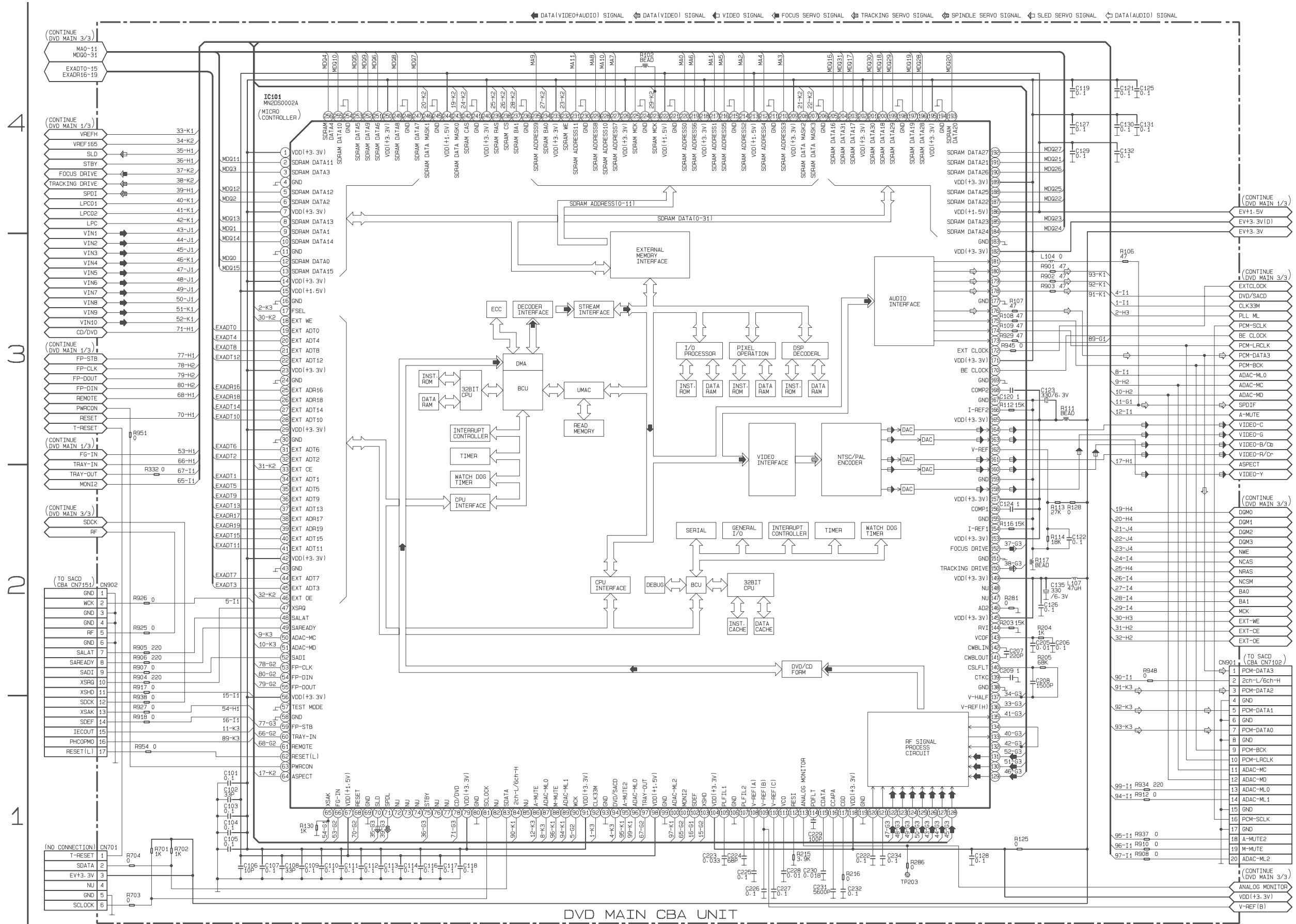

DVD MAIN CBA UNIT

IC101 VOLTAGE CHART (DV6400/N1B, DV6400/N1S)

PIN.NO	PLAY	STOP	PIN.NO	PLAY	STOP	PIN.NO	PLAY	STOP	PIN.NO	PLAY	STOP	PIN.NO	PLAY	STOP	PIN.NO	PLAY	STOP	PIN.NO	PLAY	STOP	PIN.NO	PLAY	STOP
1	3.3	3.3	33	2.2	2.9	65	0.1	0.1	97	3.4	3.4	129	2.0	2.0	161	0.5	0.5	193	~	~	225	1.9	1.9
2	~	~	34	~	~	66	1.2	2.5	98	1.6	1.6	130	2.2	2.2	162	1.4	1.4	194	0	0	226	3.3	3.3
3	~	~	35	~	~	67	1.6	1.6	99	0	0	131	2.3	2.3	163	1.4	1.4	195	3.3	3.3	227	~	~
4	0	0	36	~	~	68	3.4	3.4	100	3.4	3.4	132	0.4	0.1	164	0.9	0.9	196	~	~	228	~	~
5	~	~	37	~	~	69	0	0	101	0.2	0	133	1.2	0.4	165	3.3	3.3	197	~	~	229	~	~
6	~	~	38	0.3	0.5	70	1.7	1.7	102	0.2	0	134	0.4	0.1	166	1.5	1.5	198	0	0	230	0	0
7	3.3	3.3	39	0.1	0.1	71	2.4	1.7	103	0.2	0	135	0.2	0.2	167	0	0	199	~	~	231	~	~
8	~	~	40	~	~	72	----	----	104	3.3	3.3	136	2.3	2.3	168	2.1	2.1	200	~	~	232	3.3	3.3
9	~	~	41	~	~	73	----	----	105	0.9	0.9	137	1.7	1.7	169	0	0	201	~	~	233	3.3	3.3
10	~	~	42	3.3	3.3	74	----	----	106	0	0	138	0	0	170	0.8	0.8	202	3.3	3.3	234	1.6	1.6
11	0	0	43	0	0	75	3.4	3.4	107	0.8	0.8	139	1.7	1.7	171	3.3	3.3	203	~	~	235	~	~
12	~	~	44	~	~	76	----	----	108	1.6	1.6	140	1.7	1.7	172	1.6	1.6	204	~	~	236	0	0
13	~	~	45	~	~	77	----	----	109	2.1	2.1	141	1.7	1.7	173	0.2	0.2	205	~	~	237	1.7	1.7
14	3.3	3.3	46	2.0	2.6	78	0.1	0.1	110	2.6	2.6	142	1.7	1.7	174	1.8	1.8	206	0	0	238	3.0	3.0
15	1.5	1.5	47	3.0	3.0	79	3.3	3.3	111	2.0	2.0	143	0.5	0.5	175	1.7	1.7	207	2.4	3.5	239	3.3	3.3
16	0	0	48	3.6	3.6	80	0	0	112	0.7	0.9	144	1.6	1.6	176	1.4	0.1	208	2.4	2.1	240	3.3	3.3
17	3.4	3.4	49	3.4	3.4	81	3.3	3.3	113	2.0	2.0	145	3.3	3.3	177	0	0	209	3.3	3.3	241	0	0
18	3.4	3.4	50	3.4	3.4	82	----	----	114	1.8	1.8	146	0	0	178	0.9	0.1	210	~	~	242	3.2	3.2
19	~	~	51	3.4	3.4	83	3.4	3.4	115	1.4	1.4	147	----	----	179	1.4	0.1	211	0	0	243	2.4	2.1
20	~	~	52	3.4	3.4	84	2.4	2.4	116	0.3	0.3	148	----	----	180	1.4	0.1	212	~	~	244	1.5	1.5
21	~	~	53	3.4	3.4	85	----	----	117	1.6	1.6	149	3.3	3.3	181	1.7	1.7	213	1.5	1.5	245	0	0
22	~	~	54	3.4	3.4	86	3.4	0.1	118	3.3	3.3	150	1.7	1.7	182	3.3	3.3	214	~	~	246	2.4	2.1
23	3.3	3.3	55	3.3	3.3	87	3.4	3.4	119	0	0	151	0	0	183	0	0	215	0	0	247	~	~
24	0	0	56	3.3	3.3	88	0.1	0.1	120	1.9	1.9	152	1.7	1.7	184	~	~	216	~	~	248	0	0
25	0.4	0.4	57	0	0	89	3.4	3.4	121	1.9	1.9	153	3.3	3.3	185	~	~	217	~	~	249	~	~
26	0.9	0.6	58	0	0	90	3.6	3.6	122	2.4	2.4	154	1.4	1.4	186	1.5	1.5	218	3.3	3.3	250	3.3	3.3
27	~	~	59	3.3	3.3	91	3.3	3.3	123	2.4	2.4	155	0	0	187	~	~	219	~	~	251	~	~
28	~	~	60	3.4	3.4	92	1.7	1.5	124	2.4	2.4	156	2.2	2.2	188	~	~	220	~	~	252	~	~
29	3.3	3.3	61	3.1	3.1	93	0	0	125	2.4	2.4	157	3.3	3.3	189	3.3	3.3	221	0	0	253	~	~
30	0	0	62	3.3	3.3	94	3.6	3.6	126	2.0	2.0	158	0.7	0.7	190	~	~	222	1.5	1.5	254	0	0
31	~	~	63	3.4	3.4	95	3.4	0.1	127	2.0	2.0	159	0	0	191	~	~	223	1.9	1.9	255	~	~
32	~	~	64	0.8	0.8	96	3.4	3.4	128	2.0	2.0	160	0.5	0.5	192	~	~	224	0	0	256	~	~

DVD Main 3/3 Schematic Diagram (DV6400/N1B, DV6400/N1S)

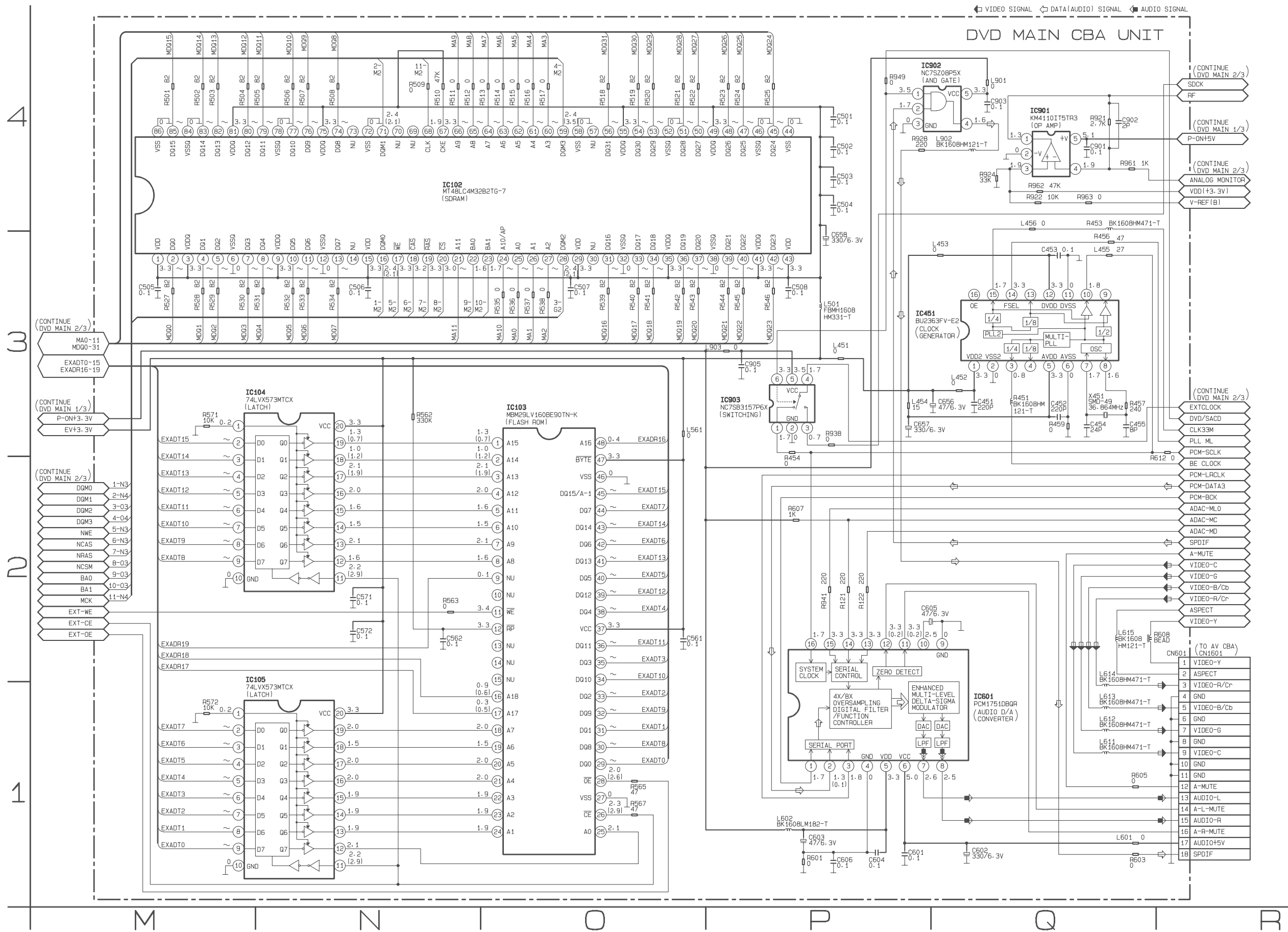

AV 1/3 Schematic Diagram (DV6400/N1B, DV6400/N1S)

CAUTION !

Fixed voltage (or Auto voltage selectable) power supply circuit is used in this unit.
If Main Fuse (F1001) is blown, check to see that all components in the power supply circuit are not defective before you connect the AC plug to the AC power supply.
Otherwise it may cause some components in the power supply circuit to fail.

CAUTION

FOR CONTINUED PROTECTION AGAINST FIRE HAZARD,
REPLACE ONLY WITH THE SAME TYPE FUSE.

NOTE :

THE VOLTAGE FOR PARTS IN HOT CIRCUIT IS MEASURED USING
HOT GND AS A COMMON TERMINAL.

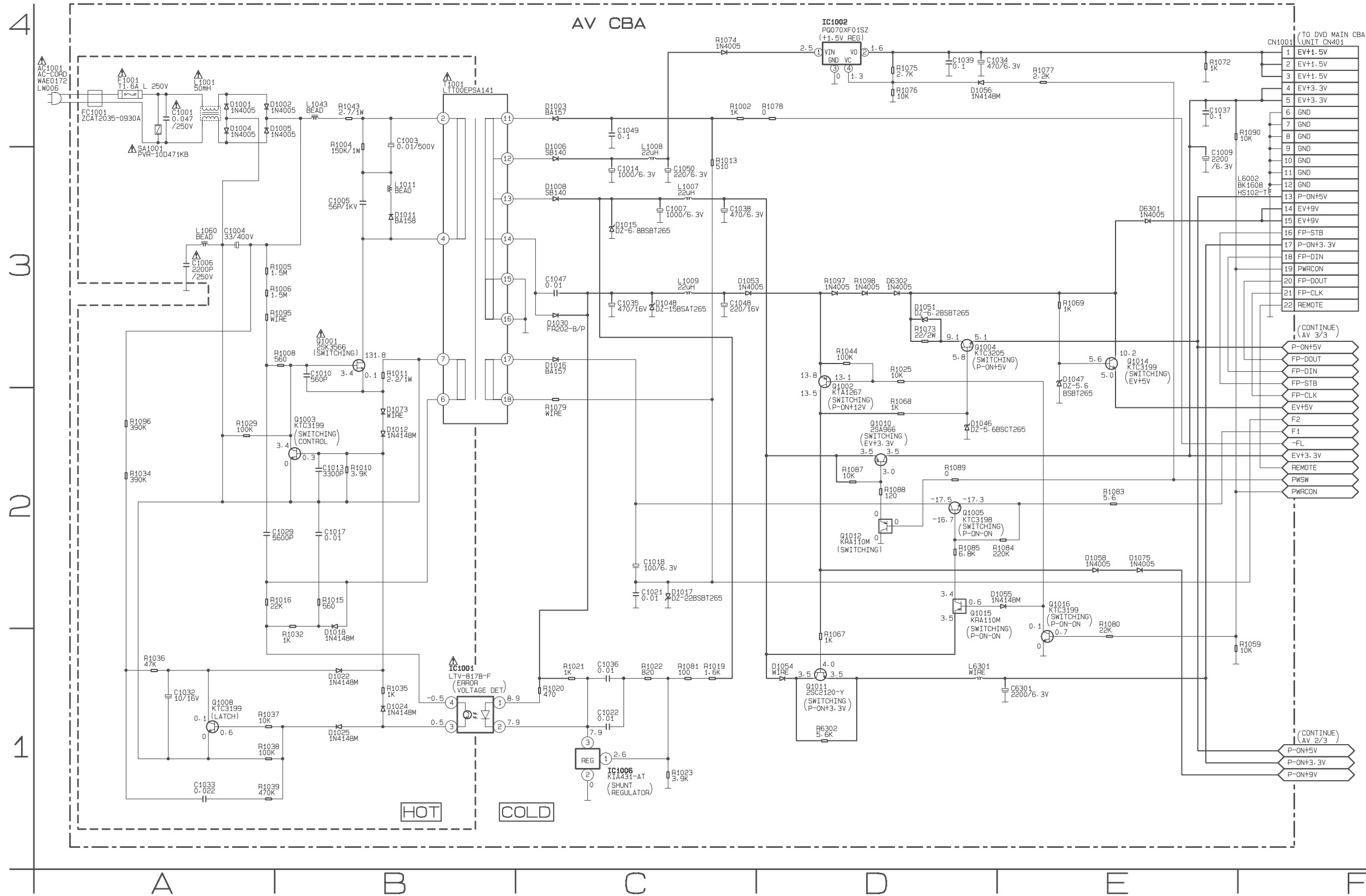

AV 2/3 Schematic Diagram (DV6400/N1B, DV6400/N1S)

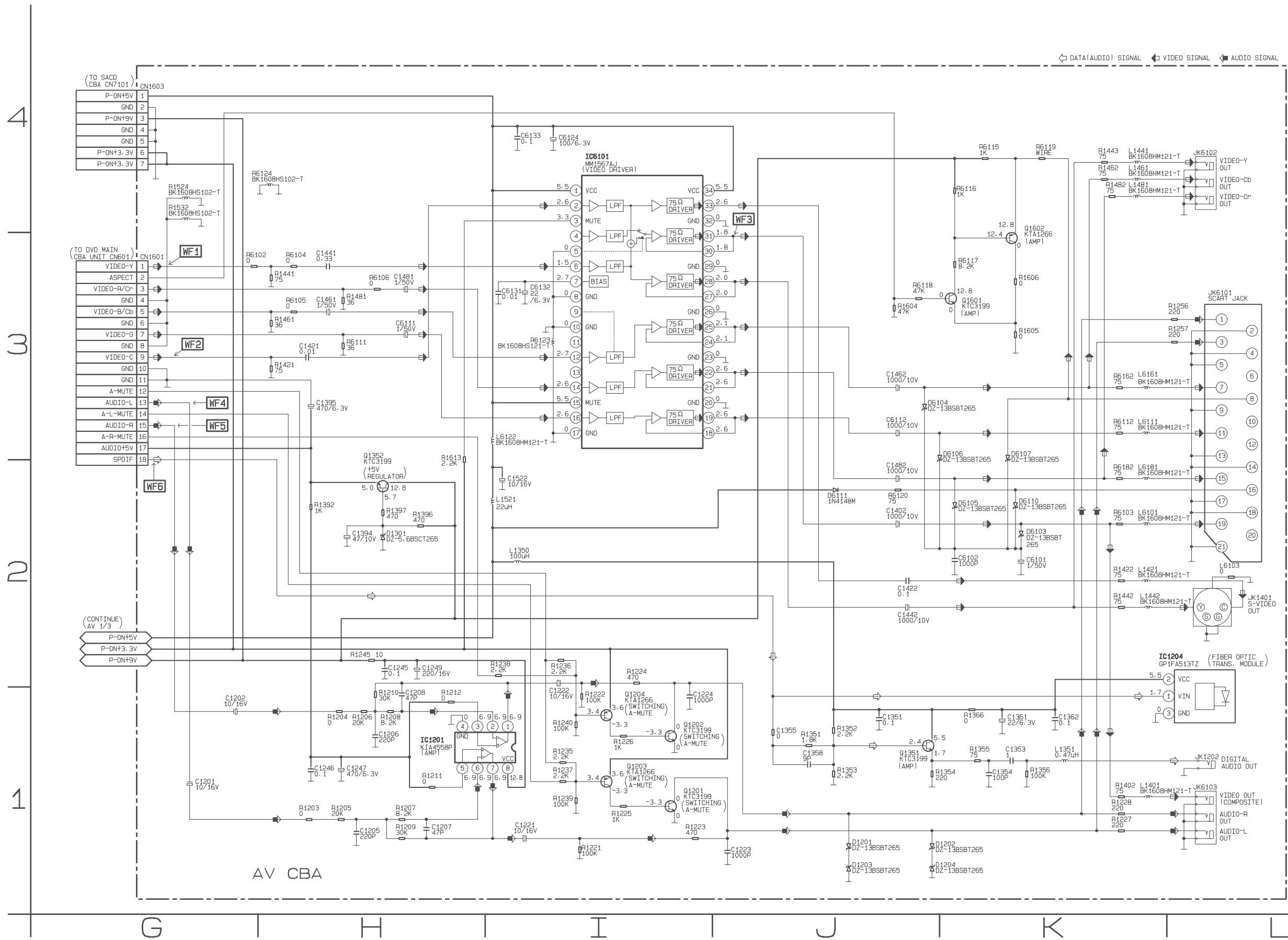

AV 3/3, Function, Switch & LED Schematic Diagram (DV6400/N1B, DV6400/N1S)

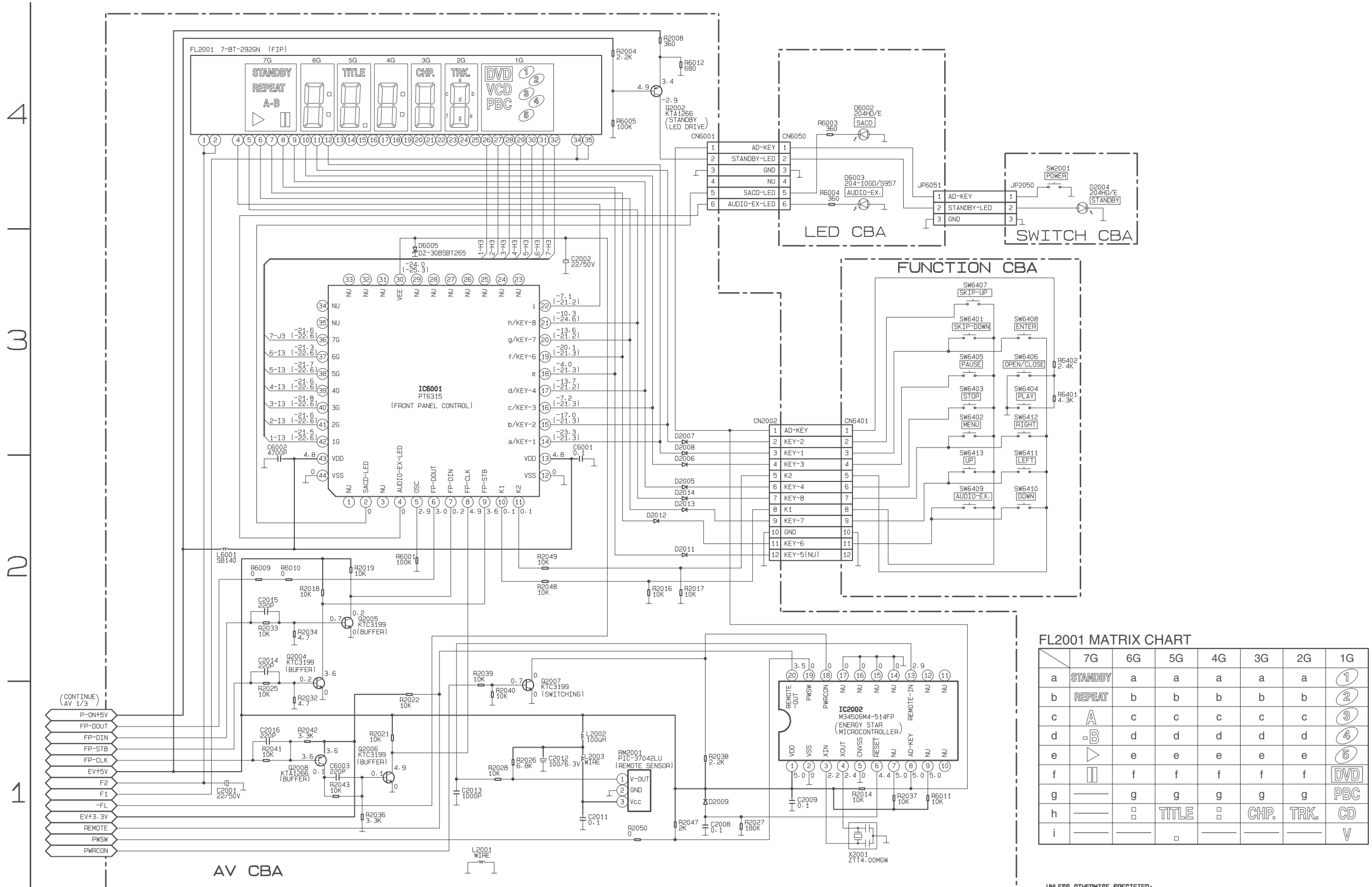

FL2001 MATRIX CHART

	7G	6G	5G	4G	3G	2G	1G
a	STANDBY	a	a	a	a	a	①
b	REPEAT	b	b	b	b	b	②
c	A	c	c	c	c	c	③
d	B	d	d	d	d	d	④
e	▶	e	e	e	e	e	⑤
f	⏸	f	f	f	f	f	DVD
g	—	g	g	g	g	g	PBC
h	□	TITLE	□	CHP.	TRK.	CD	
i	—	□	—	—	—	—	V

UNLESS OTHERWISE SPECIFIED, SWITCHES ARE K5M0614B.

AV CBA Top View (DV4400/N1B, DV4400/N1S, DV6400/N1B, DV6400/N1S)

CAUTION !

Fixed voltage (or Auto voltage selectable) power supply circuit is used in this unit.
If Main Fuse (F1001) is blown, check to see that all components in the power supply circuit are not defective before you connect the AC plug to the AC power supply.
Otherwise it may cause some components in the power supply circuit to fail.

CAUTION

FOR CONTINUED PROTECTION AGAINST FIRE HAZARD,
REPLACE ONLY WITH THE SAME TYPE FUSE.

NOTE :

The voltage for parts in hot circuit is measured using hot GND as a common terminal.

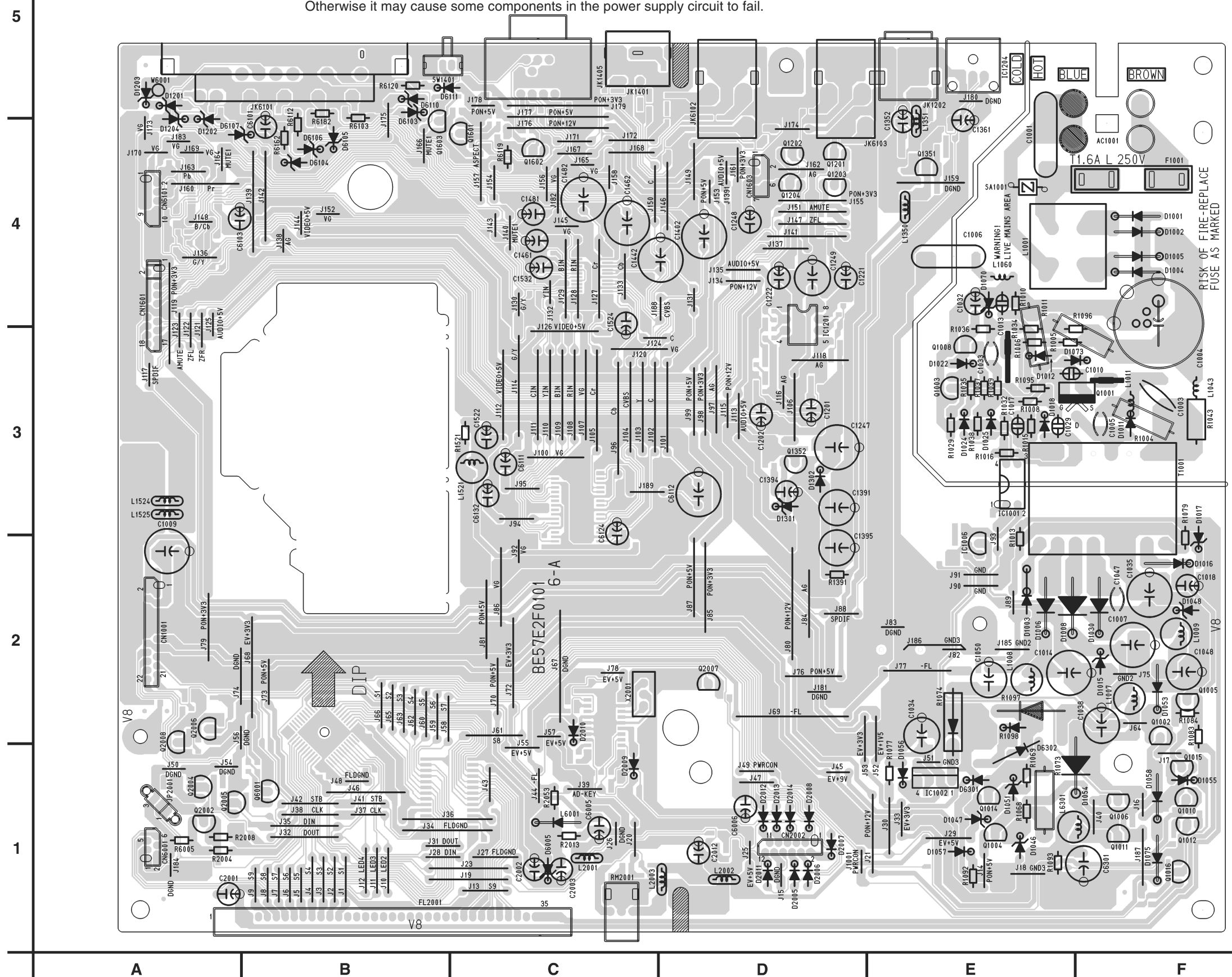

LED CBA Top View
 (DV4400/N1B, DV4400/N1S, DV6400/N1B, DV6400/N1S)

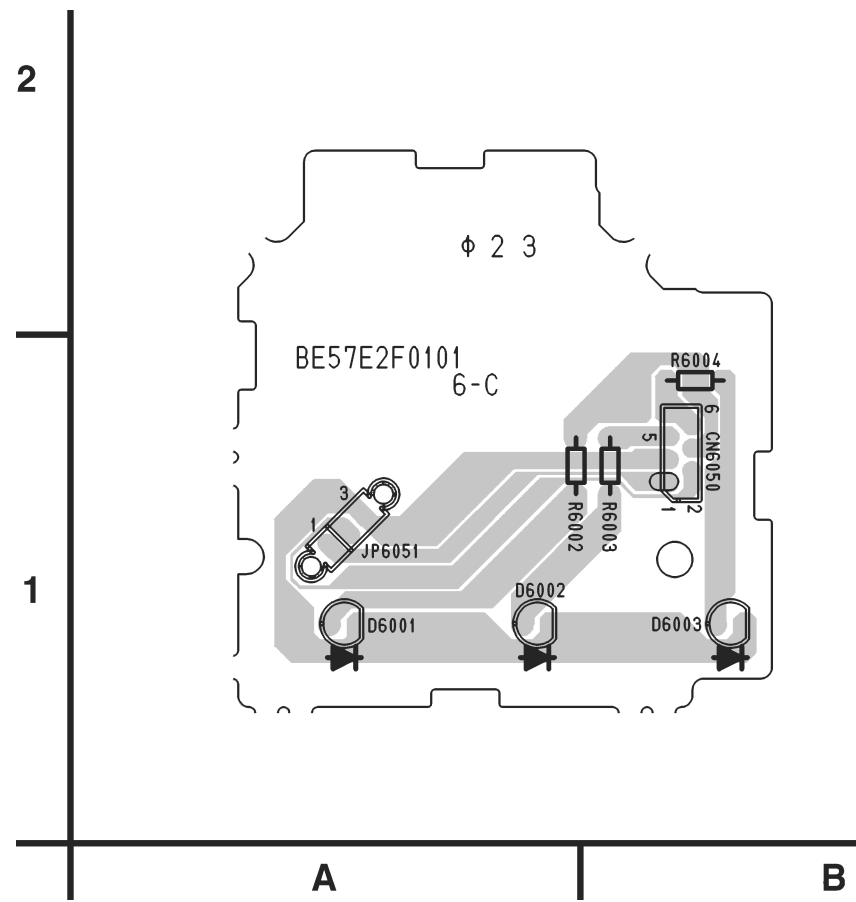

LED CBA Bottom View
 (DV4400/N1B, DV4400/N1S, DV6400/N1B, DV6400/N1S)

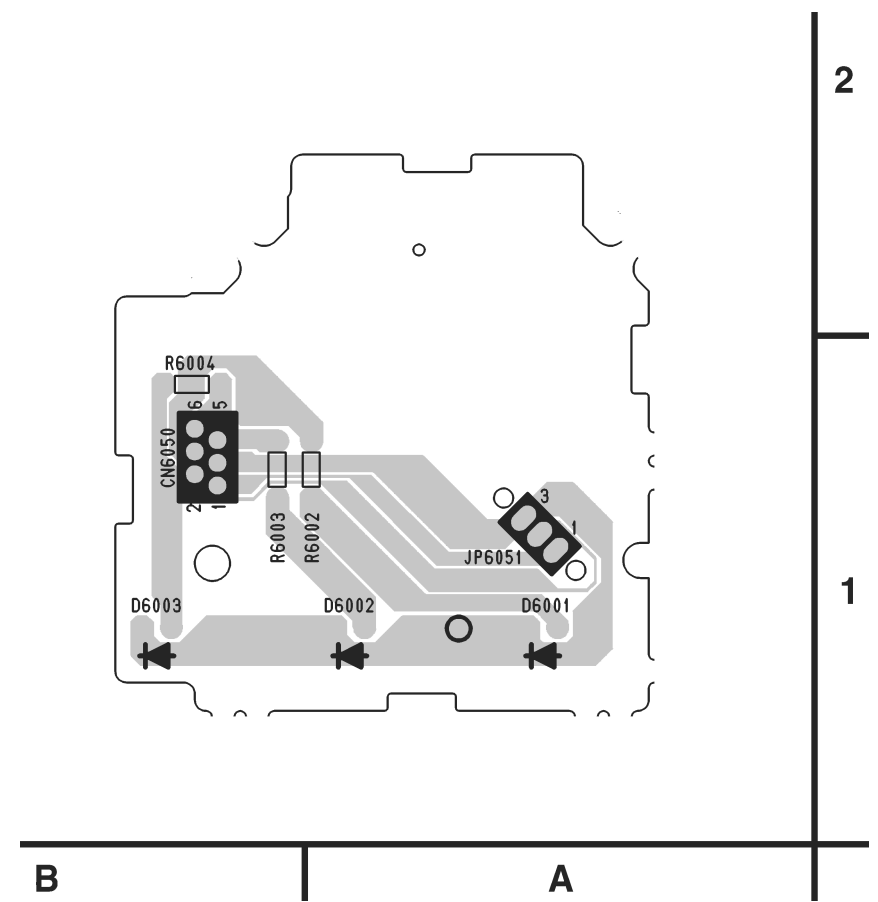

BE57E2F01016-C

Switch CBA Top/Bottom View (DV4400/N1B, DV4400/N1S, DV6400/N1B, DV6400/N1S)

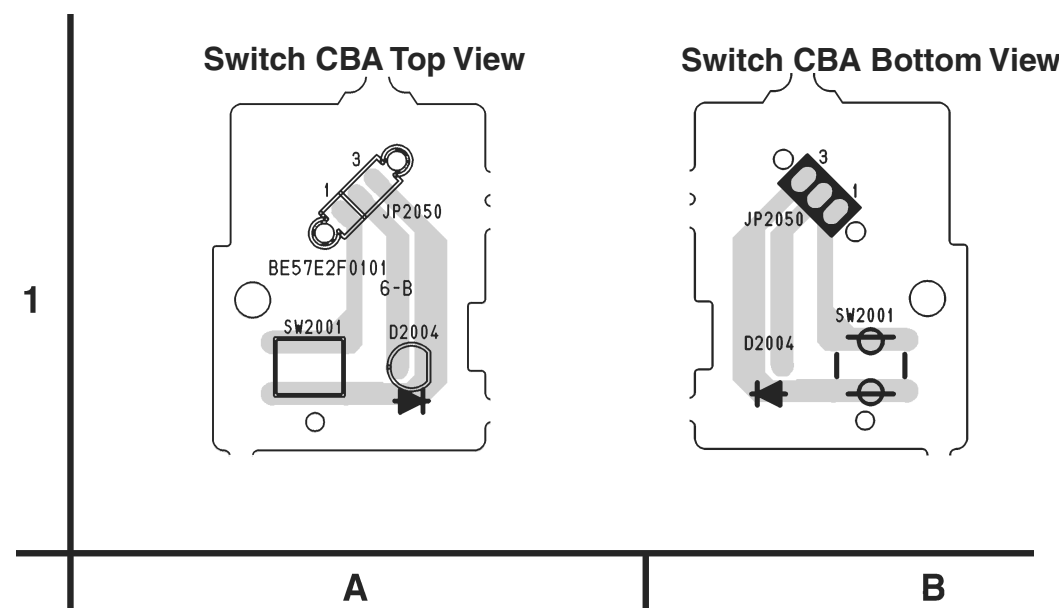

BE57E2F01016-B

Function CBA Top View
 (DV4400/N1B, DV4400/N1S, DV6400/N1B, DV6400/N1S)

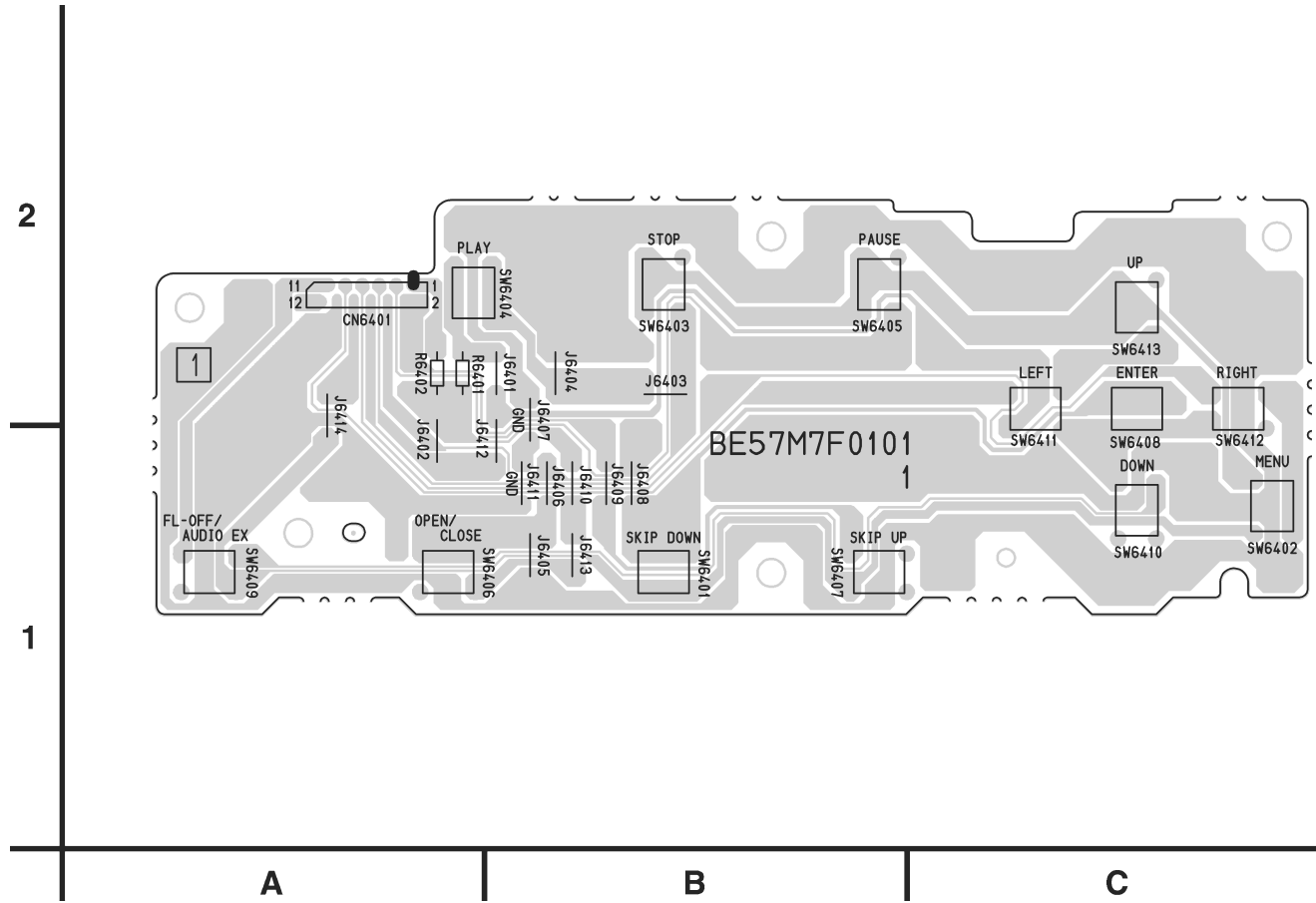

Function CBA Bottom View
 (DV4400/N1B, DV4400/N1S, DV6400/N1B, DV6400/N1S)

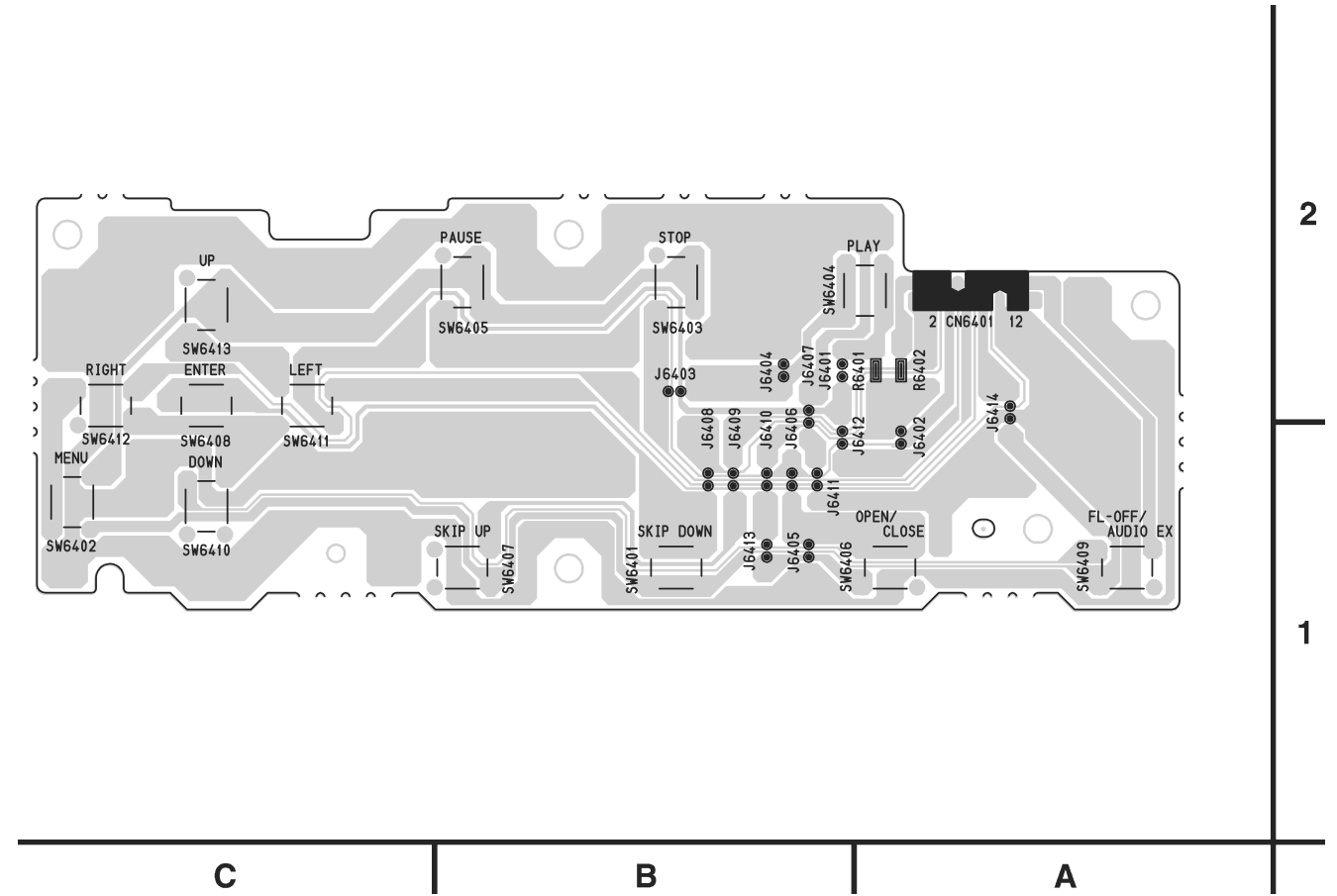

SACD CBA Top View (DV6400/N1B, DV6400/N1S)

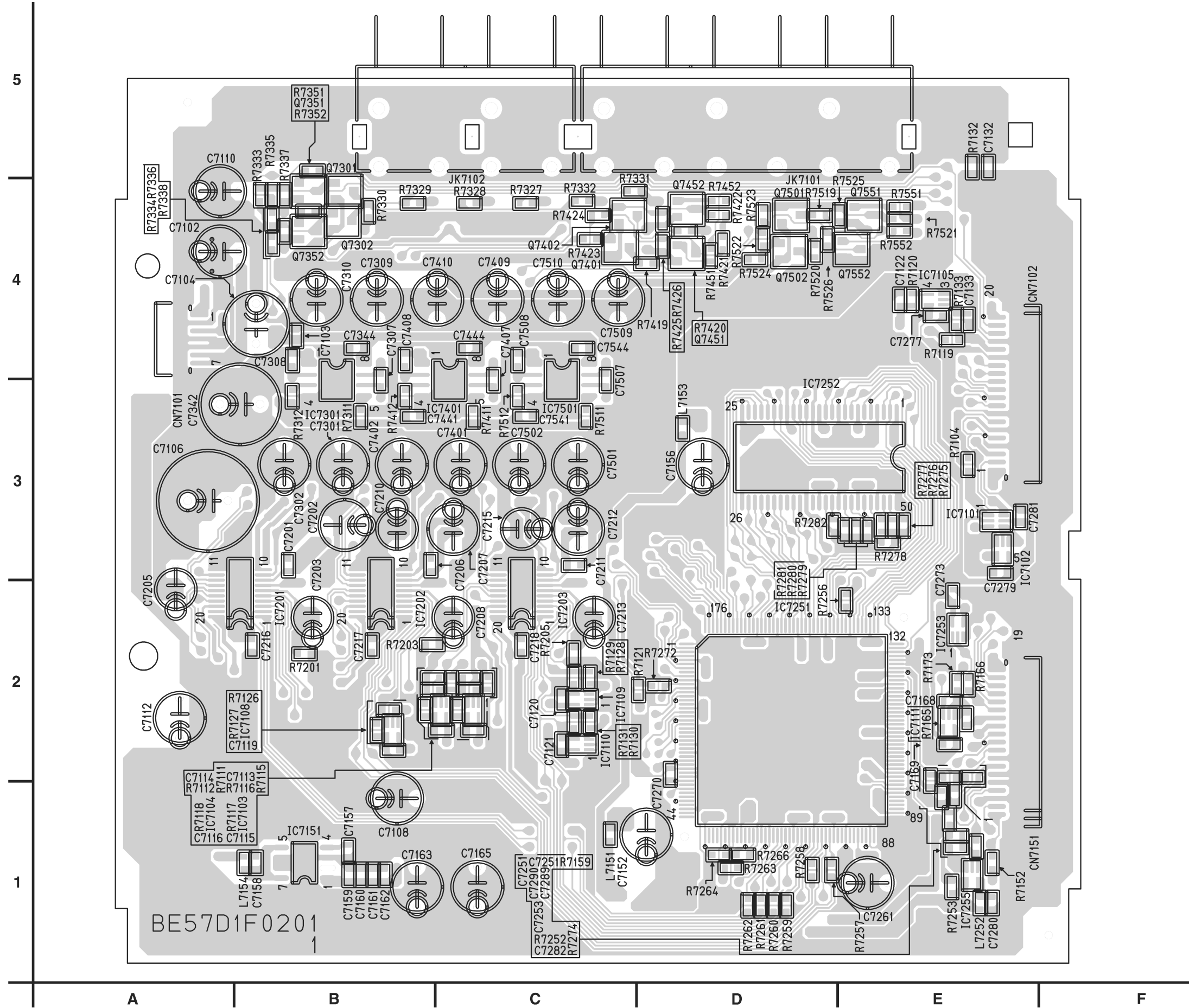

SACD CBA Bottom View (DV6400/N1B, DV6400/N1S)

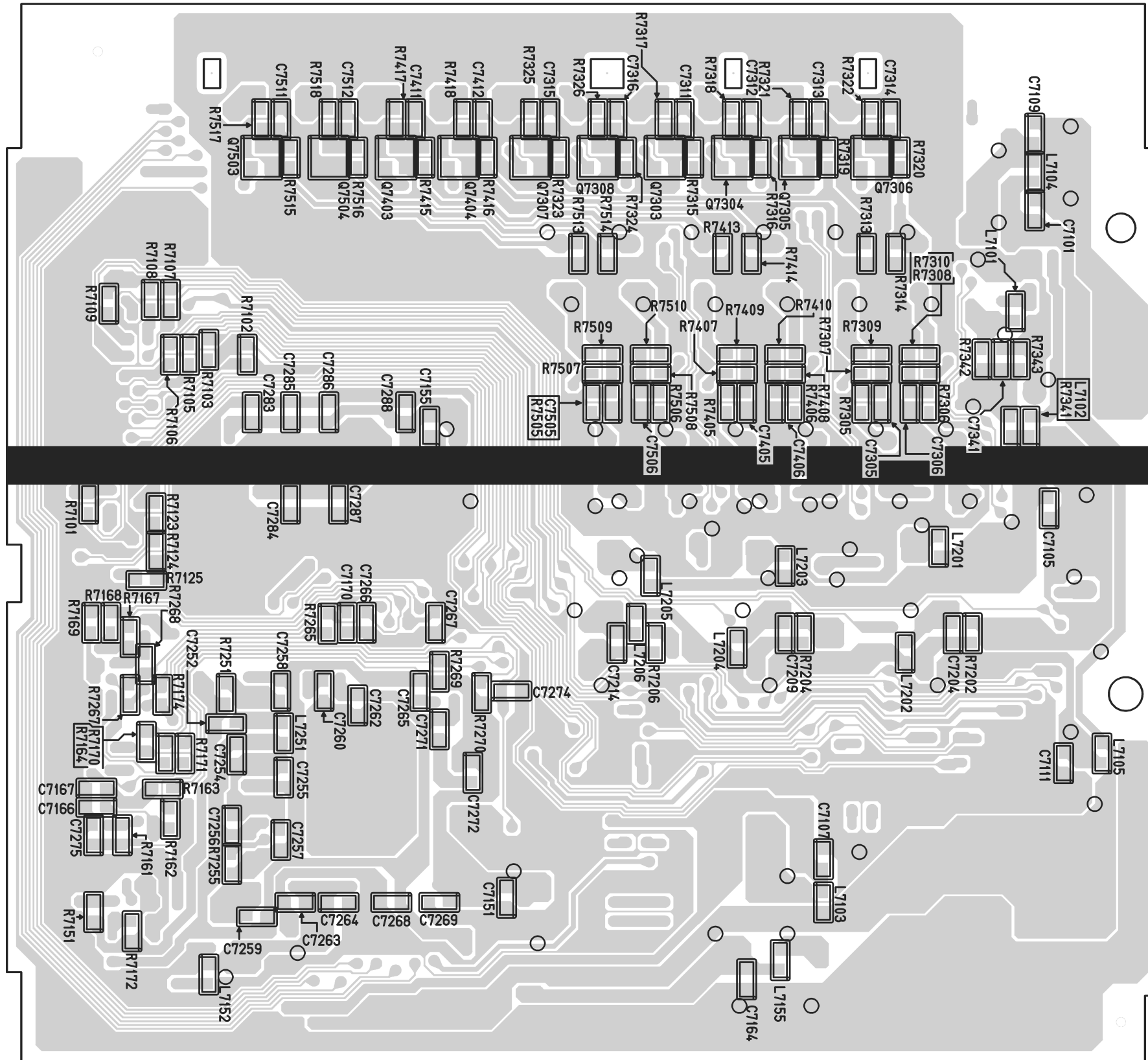

WAVEFORMS

WF1 Pin 1 of CN1601

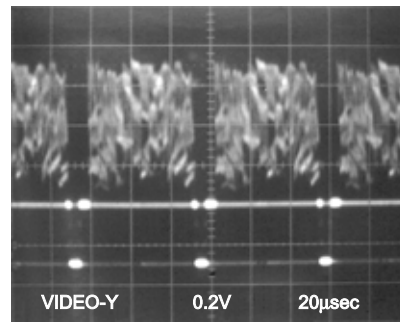

WF5 Pin 15 of CN1601

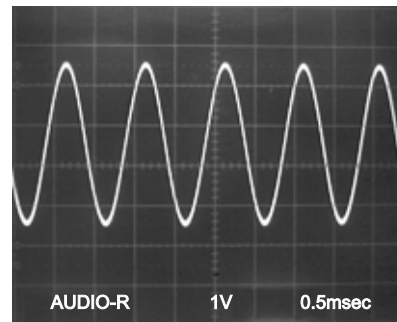

NOTE:

Input

CD: 1kHz PLAY
(WF4~WF6)

DVD: POWER ON (STOP) MODE
(WF1~WF3)

WF2 Pin 9 of CN1601

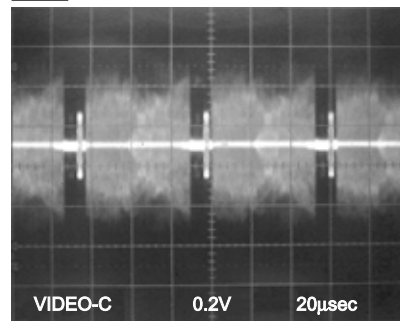

WF6 Pin 18 of CN1601

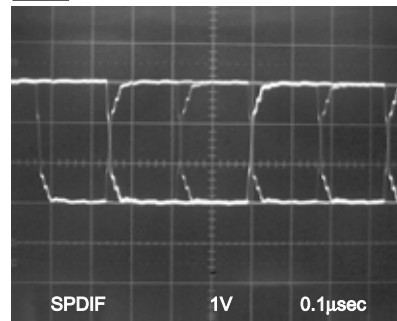

WF3 Pin 31 of IC6101

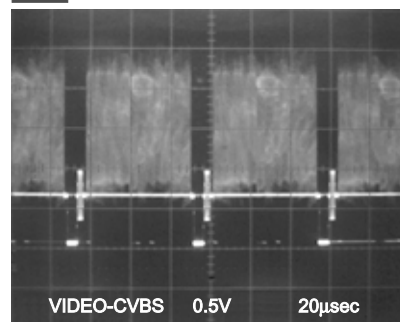

WF4 Pin 13 of CN1601

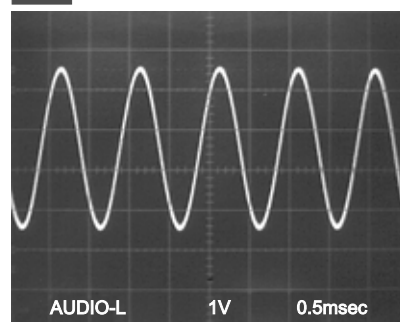

WIRING DIAGRAM (DV4400/N1B, DV4400/N1S)

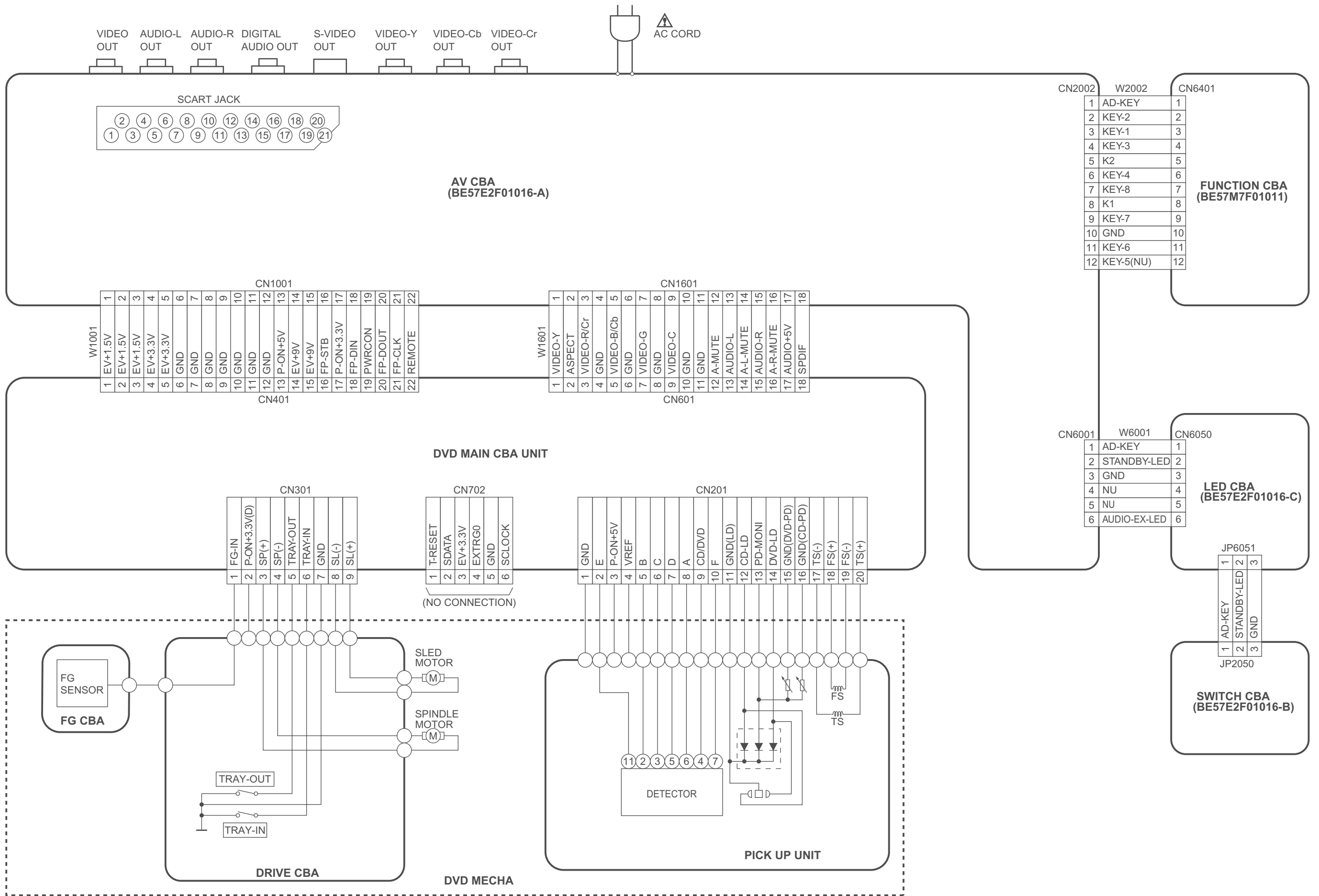

WIRING DIAGRAM (DV6400/N1B, DV6400/N1S)

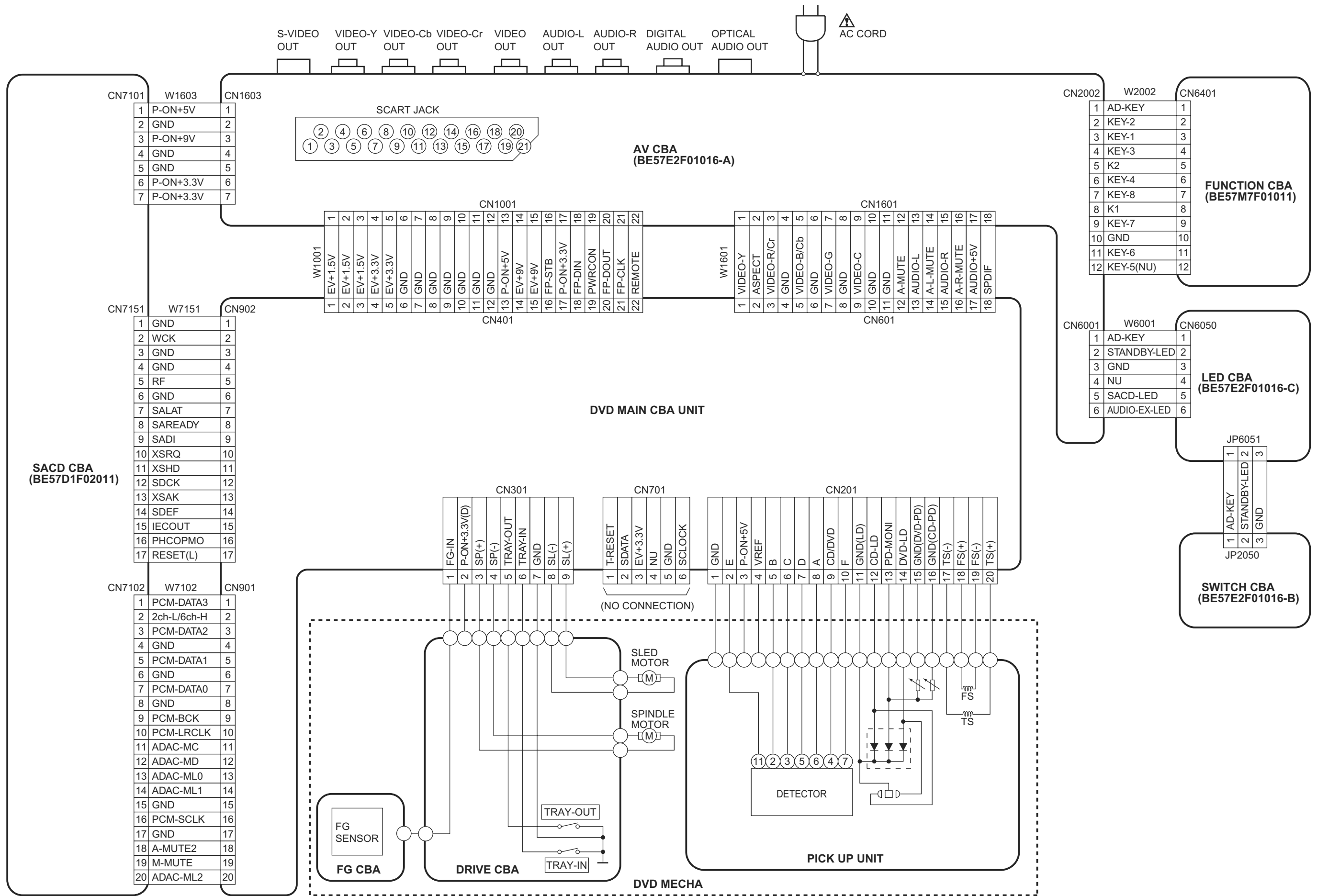

FIRMWARE RENEWAL MODE

1. Turn the power on and remove the disc on the tray.
2. To put the DVD player into version up mode, press [9], [8], [7], [6], and [SEARCH MODE] buttons on the remote control unit in that order. The tray will open automatically.

Fig. a appears on the screen and Fig. b appears on the VFD.

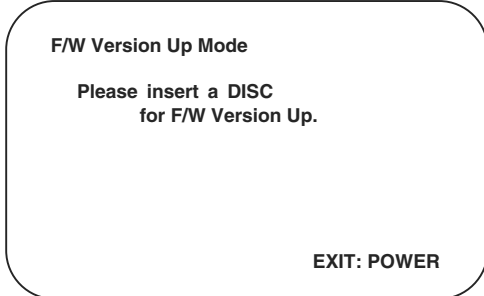

Fig. a Version Up Mode Screen



Fig. b VFD in Version Up Mode

The DVD player can also enter the version up mode with the tray open. In this case, Fig. a will be shown on the screen while the tray is open.

3. Load the disc for version up.
4. The DVD player enters the F/W version up mode automatically. Fig. c appears on the screen and Fig. d appears on the VFD.

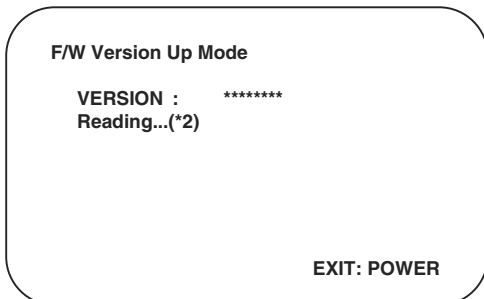

Fig. c Programming Mode Screen



Fig. d VFD in Programming Mode (Example)

The appearance shown in (*2) of Fig. c is described as follows:

No.	Appearance	State
1	Reading...	Sending files into the memory
2	Erasing...	Erasing previous version data
3	Programming...	Writing new version data

5. After programming is finished, the tray opens automatically. Fig. e appears on the screen and the checksum in (*3) of Fig. e appears on the VFD. (Fig. f)

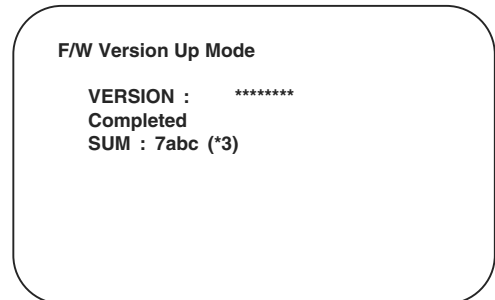

Fig. e Completed Program Mode Screen



Fig. f VFD upon Finishing the Programming Mode (Example)

At this time, no buttons are available.

6. Unplug the AC cord from the AC outlet. Then plug it again.
7. Turn the power on by pressing the power button and the tray will close.
8. Press [1], [2], [3], [4], and [DISPLAY] buttons on the remote control unit in that order. Fig. g appears on the screen.

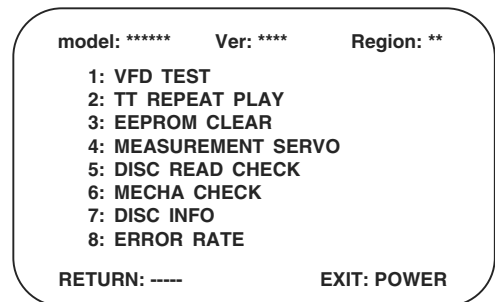

Fig. g

9. Press [3] button on the remote control unit. Fig. h appears on the screen.

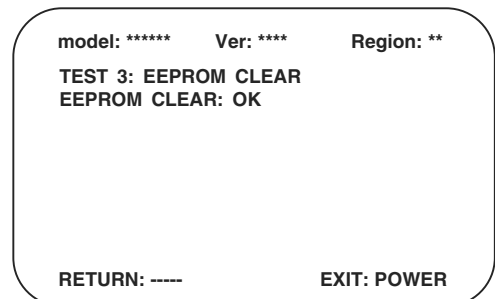
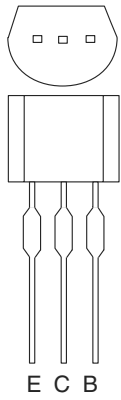

Fig. h

10. To exit this mode, press [POWER] button.

LEAD IDENTIFICATIONS



2SA1015-Y (TPE2)
KIA1266 (Y)
KTC3198 (Y)
2SC2120-Y(TPE2)
KTC3205 (Y)
2SC2236-Y-TPE6,C
2SA966(Y)

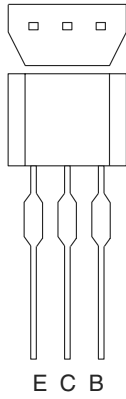

2SC2785 (H)
KTC3199 (GR)
KRA110M
KTA1267 (Y)
BN1L3Z (P)

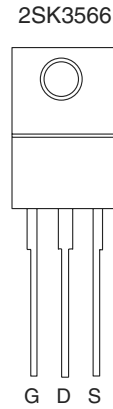

2SC2412K T146S
KRA105S-RTK
KTC3875GR-RTK

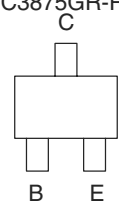

NJM4558D
KIA4558P
NJM4580MTE1

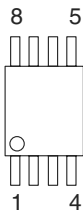

MM1567AJ

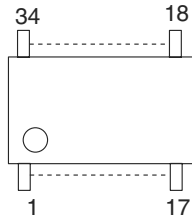

NC7SZ08P5X

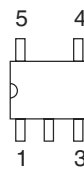

KIA431-AT

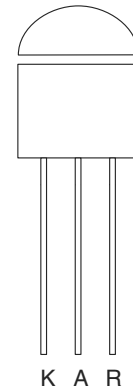

CXD2753R

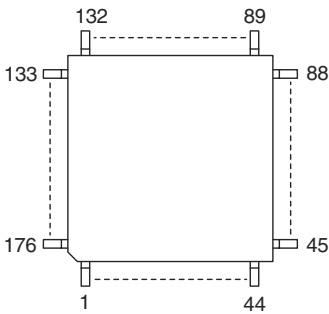

MIM1562FFBE

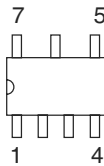

K4S161622D-TC80

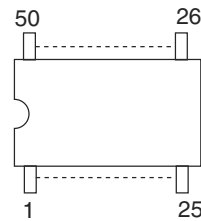

GP1FA513TZ

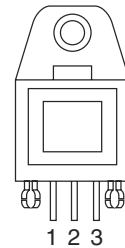

PT6315

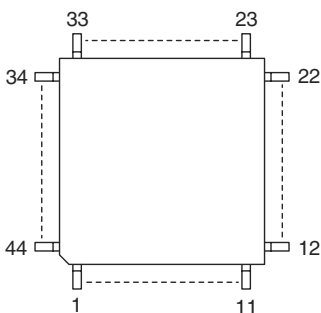

PQ070XF01SZ

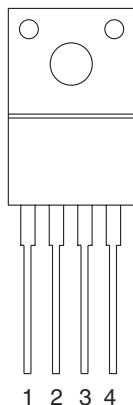

1: Vin
2: Vo
3: GND
4: Vc

LTV-817(B,C)-F

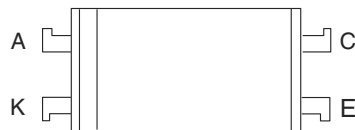

NC7SB3157P6X

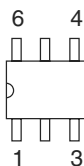

M34506M4-506FP
DSD1702E/2K

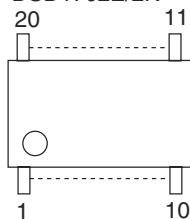

Note:

A: Anode
K: Cathode
E: Emitter
C: Collector
B: Base
R: Reference
G: Gate
D: Drain
S: Source

EXPLODED VIEWS

Cabinet

[DV4400/N1B, DV4400/N1S]

See Electrical Parts List for parts with this mark.

Some Ref. Numbers are not in sequence.

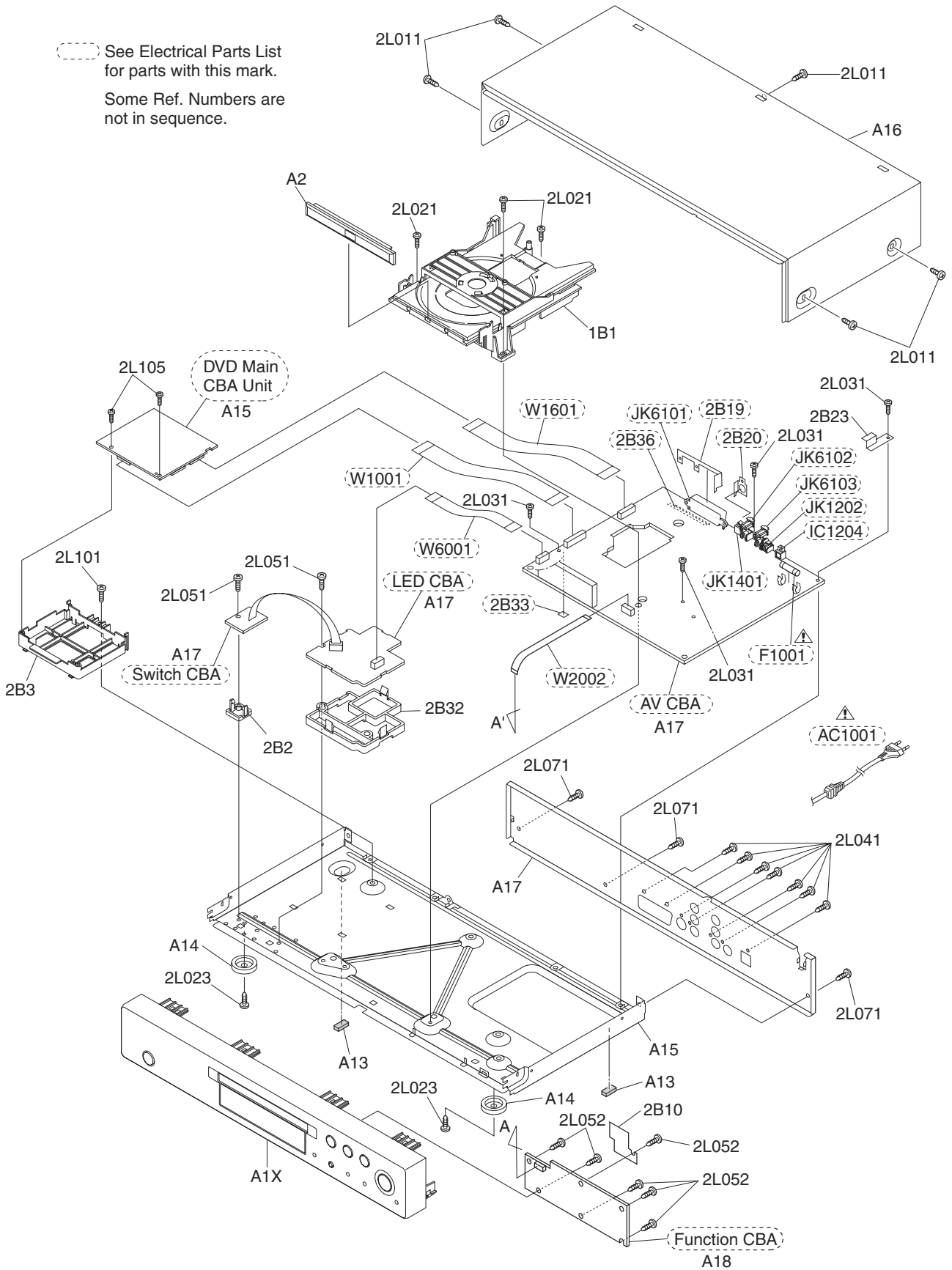

[DV6400/N1B, DV6400/N1S]

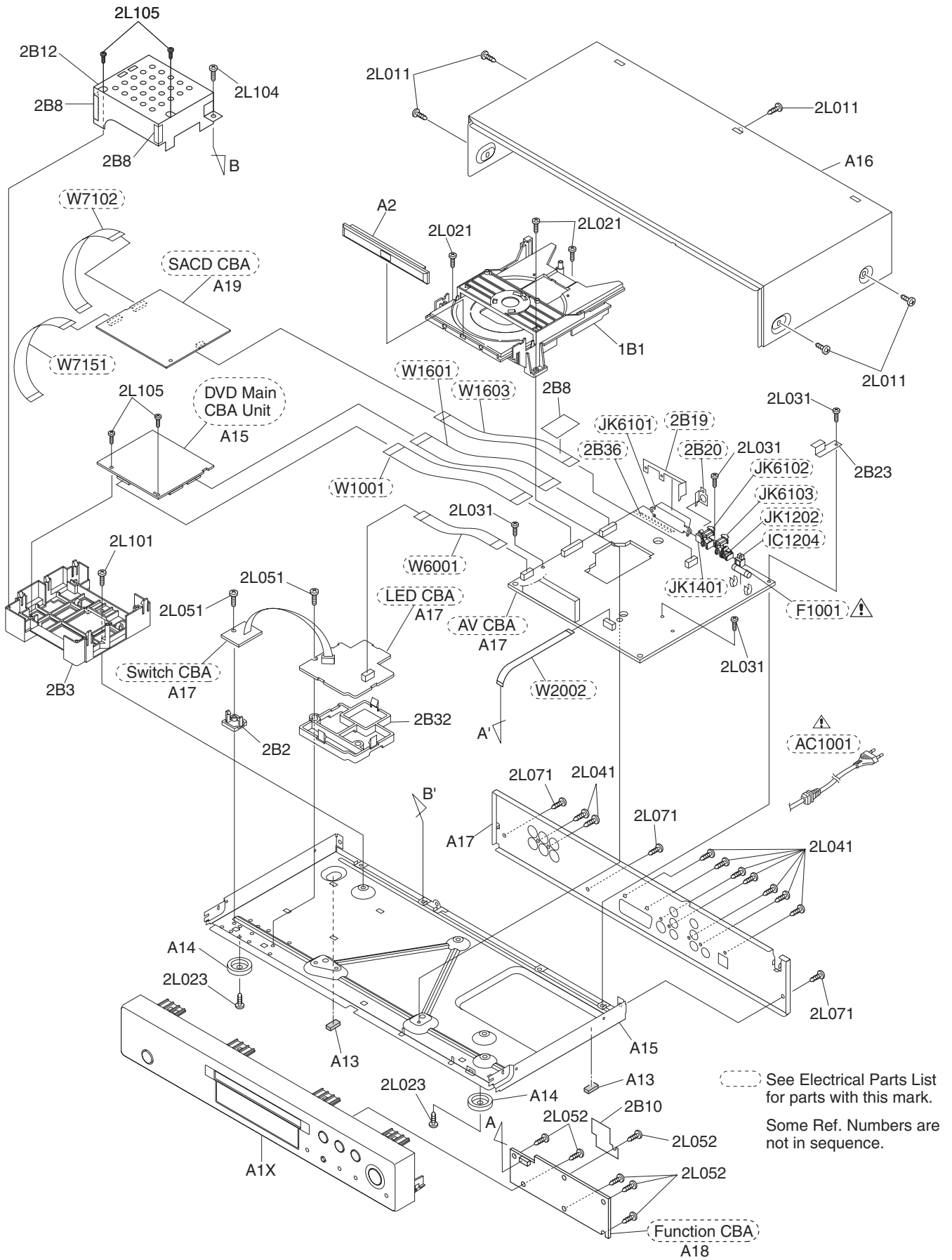

See Electrical Parts List for parts with this mark.
Some Ref. Numbers are not in sequence.

Packing

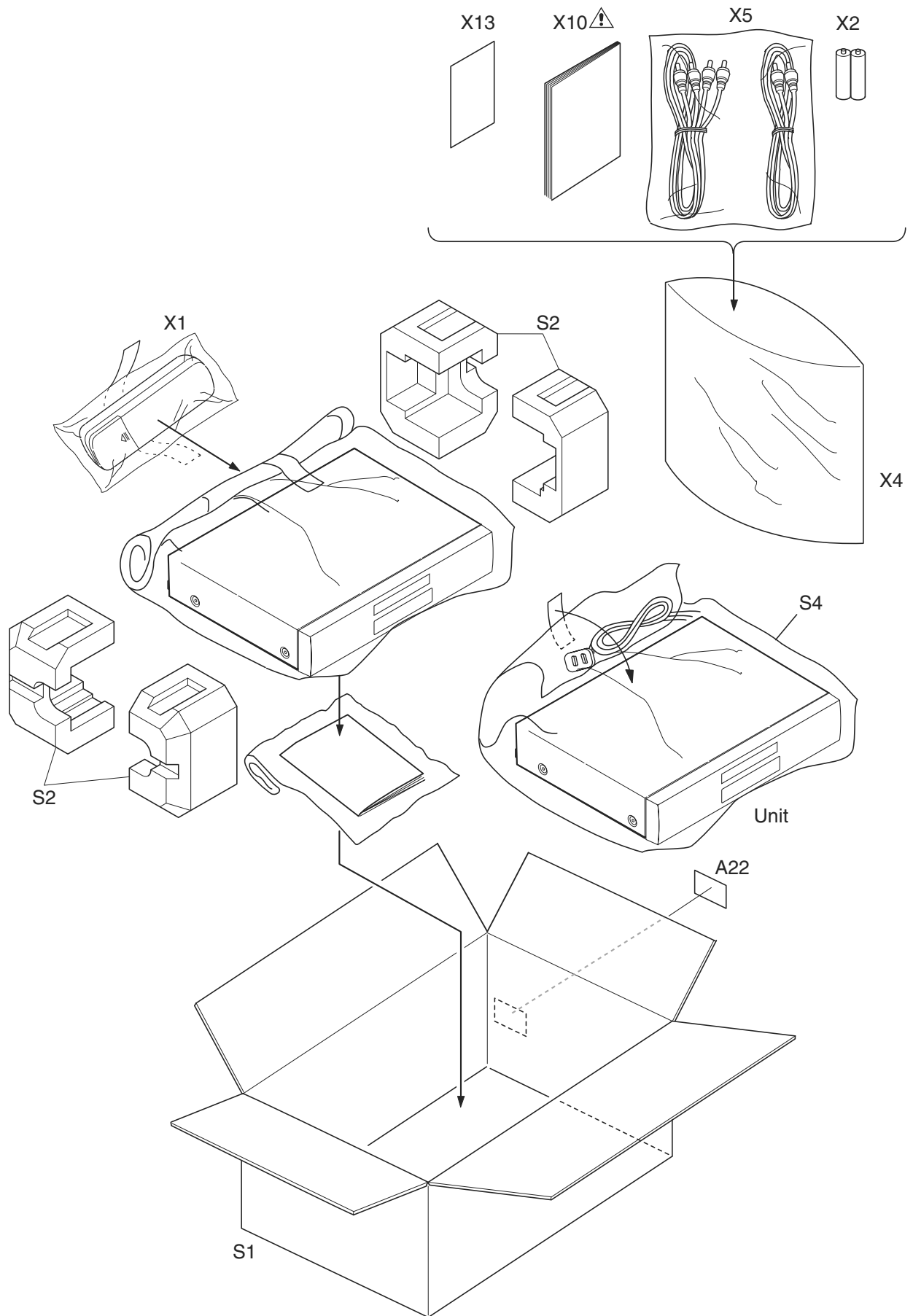

PARTS LIST [DV4400]

POS. NO	VERS. COLOR	PART NO. (FOR EUR)	PART NO. (MJJ)	DESCRIPTION			
EXPLODED VIEW PARTS							
A1X	/F1N/S1G	nsp	44AW248140	FRONT PANEL (GOLD)	FRONT ASSY E57M1JD	0VM204448	
A1X	/N1B	44AW248010	44AW248010	FRONT PANEL (BLACK)	FRONT ASSY E57M2ED	0VM204412	
A1X	/N1S	44AW248210	44AW248210	FRONT PANEL(SILVER)	FRONT ASSY E57M4ED	0VM204413	
A1X	/U1B	nsp	44AW248020	FRONT PANEL(BLACK)	FRONT ASSY E57M0UD	0VM204463	
A2	GOLD	nsp	44AW063140	ESCUTCHEON	TRAY PANEL E57M1JD	0VM416074	
A2	BLACK	44AW063010	44AW063010	ESCUTCHEON	TRAY PANEL E57M0UD	0VM204372	
A2	SILVER	44AW063210	44AW063210	ESCUTCHEON	TRAY PANEL E57M4ED	0VM416014	
A13		44AW057020	44AW057020	LEG	FOOT(REAR) E5710UD	0VM415007	
A14	BLACK, GOLD	44AW057010	44AW057010	LEG	LEG ASSY E57M0UD	0VM415913	
A14	SILVER	44AW057210	44AW057210	LEG	LEG ASSY E57M4ED	0VM416056	
1B1		44AW304010	44AW304010	MACHA LOADER / MECHA TRAVERSE	DVD MECHA 0838 VCDVM040	N79F0GVGM	
A15	/N	*ZZ002230R	*ZZ002230R	PCB ASSY	DVD MAIN CBA UNIT	N79B0GEP	
A15	/F	nsp	*ZZ002350R	PCB ASSY	DVD MAIN CBA UNIT	N79B6GJP	
A15	/S	nsp	*ZZ002420R	PCB ASSY	DVD MAIN CBA UNIT	N79B2GPP	
A15	/U	nsp	*ZZ002360R	PCB ASSY	DVD MAIN CBA UNIT	N79B4GUP	
A17	/N	*ZZ002240R	*ZZ002240R	PCB ASSY	AV CBA ASSY / LED CBS ASSY / Switch CBA ASSY	0VSA14603	
A17	/F	nsp	*ZZ002330R	PCB ASSY	AV CBA ASSY / LED CBS ASSY / Switch CBA ASSY	0VSA14685	
A17	/S	nsp	*ZZ002430R	PCB ASSY	AV CBA ASSY / LED CBS ASSY / Switch CBA ASSY	0VSA14776	
A17	/U	nsp	*ZZ002340R	PCB ASSY	AV CBA ASSY / LED CBS ASSY / Switch CBA ASSY	0VSA14682	
A18		*ZZ002250R	*ZZ002250R	PCB ASSY	FUNCTION CBA ASSY	0VSA14617	
▲	AC1001	/N/S	*YC000820R	*YC000820R	MAINS CORD	MAINS CORD PE8B2CG980A-057	WAE0172LW006
▲	AC1001	/F	nsp	*YC000830R	MAINS CORD	MAINS CORD PP8B5PB110AA057	WAJ0172LW009
▲	AC1001	/U	nsp	*YC000840R	MAINS CORD	MAINS CORD A0A0280-007 OR PB8K9F9110A-057	WAC0172LTE04 OR WAC0172LW008
W1001		*YU001380R	*YU001380R	FPC	22P FFC AV PCB TO MAIN	WX1E5700-003	
W1601	/F/N/U	*YU001390R	*YU001390R	FPC	18P FFC DVD-A PCB TO MAIN	WX1E5700-002	
W1601	/S	nsp	*YU001450R	FPC	16P FFC DVD-A PCB TO MAIN	WX1E5700-005	
W2002		*YU001400R	*YU001400R	FPC	12P FFC AV PCB TO FNT PCB	WX1E5610-001	
W6001		*YU001410R	*YU001410R	FPC	6P FFC OR AWG22#1007 AV PCB TO LED PCB	WX1E57D1-003 OR WX3001A24405	
PACKING							
X1		ZK44AW0010	ZK44AW0010	UNIT KIT	REMOTE CONTROLLER RC6400DV NA638UD		
X10	/F	nsp	44AW851110	USER GUIDE	USER GUIDE E57M1JD	0VMN03857	
X10	/N	44AW851310	44AW851310	USER GUIDE	USER GUIDE E57M2ED	0VMN03871	
X10	/S	nsp	44AW851350	USER GUIDE	USER GUIDE E57M3PD	0VMN03872	
X10	/U	nsp	44AW851250	USER GUIDE	USER GUIDE E57M0UD	0VMN03859	
NOT STANDARD SPARE PARTS							
A16	GOLD	nsp	44AW257110	LID	TOP COVER GOLD E57E2ED	0VM306454	
A16	BLACK	nsp	44AW257010	LID	TOP COVER BLACK E5600UD	0VM101038	
A16	SILVER	nsp	44AW257210	LID	TOP COVER SILVER E56A0UD	0VM305312C	
S1	/S	nsp	44AW801020	CARTON BOX	GIFT BOX CARTON E57M3PD	0VM306701	
S1	/F/N/U	nsp	44AW801010	CARTON BOX	GIFT BOX CARTON E57M2ED	0VM306634	
S2		nsp	44AW809010	CUSHION	CUSHION E57M0UD	0VM101316	
ELECTRICAL PARTS LIST							
AV CBA							
▲	C1001	/F/U	nsp	*DF100390R	FILM CAP.	0.01µF/250V K OR 0.01µF/275V K OR 0.01µF/250V M	CT2E103DC011 OR CT2E103HJE05 OR CT2E103MS037
▲	C1001	/N/S	*DF100360R	*DF100360R	FILM CAP.	0.047µF/250V K OR M	CT2E473DC011 OR CT2E473MS037

NOTE : "nsp" PART IS LISTED FOR REFERENCE ONLY, MARANTZ WILL NOT SUPPLY THESE PARTS.

PARTS LIST [DV4400]

POS. NO	VERS. COLOR	PART NO. (FOR EUR)	PART NO. (MJI)	DESCRIPTION		
▲ C1006	/F/U	nsp	*DK100860R	CERAMIC CAP.	2200pF/250V OR 2200pF/125V	CCD2EMA0E222 OR CCG2EMA0F222 OR CCG2BMA0E222
▲ C1006	/N	*DK100850R	*DK100850R	CERAMIC CAP.	SAFETY CAP. 2200pF/250V	CCN2EMA0E222 OR CA2E222MR049
▲ F1001	/F/U	nsp	*FS001140R	FUSE	FUSE 1A/250V	PAGA20CW3102 OR PAGG20CAG102
▲ F1001	/N/S	*FS001120R	*FS001120R	FUSE	FUSE T1.6AL/250V	PAGC20BW3162 OR 1790994
IC1204		*YJ002710R	*YJ002710R	OPT. CONNECTOR	OPTIC TRANS.MODULE GP1FA513TZ	JWHHA00SH005
JK1202		*YT003370R	*YT003370R	TERMINAL	CINCH JACK(BLACK) MSP-251V-01 NI	JXRL010LY070
JK1401		*YT003380R	*YT003380R	TERMINAL	S TYPE JACK MDC-050V-2.4	JXEL040LY001
JK1405	/F	nsp	*YT003560R	TERMINAL	D TERMINAL 14P DT-0102*001	JBTD14JD002
JK6101	/N	*YT003390R	*YT003390R	TERMINAL	SCART CONNECTOR 21P RGB AJ-2050*040	JXGL210JD002
JK6102	/N/S/U	*YT003400R	*YT003400R	TERMINAL	CINCH JACK 3PIN MSD-243V-18 NI	JXRL030LY073
JK6103		*YT003410R	*YT003410R	TERMINAL	CINCH JACK 3PIN MSD-243V-15 NI	JXRL030LY079
▲ L1001	/F/U	nsp	*FN000200R	FILTER	LINE FILTER 20MH SA-00911	LLBG00ZSA003
▲ L1001	/N/S	*FN000190R	*FN000190R	FILTER	50mH LF-4Z-E503/LF-4D-E503/TLF14CB5630R2	LLBG00ZKQ008 OR LLBG00ZKQ009 OR LLBG00ZTU022
▲ SA1001		*HV000050R	*HV000050R	VARISTOR	PVR-10D471KB/CNR-10D471K	NVQZ10D471KB OR NVQZR10D471K
▲ T1001	/F/U	nsp	*TP000070R	TRANSF.	PULSE TRANS CSA-SW0215B	LTT00CPSA132
▲ T1001	/N	*TS002050R	*TS002050R	TRANSF.	MAINS TRANSFORMER CSA-SW0215C	LTT00EPSA141
▲ T1001	/S	nsp	*TS002070R	TRANSF.	MAINS TRANSFORMER CSA-SW0308A	LTT00ZPSA144

NOTE : *nsp* PART IS LISTED FOR REFERENCE ONLY, MARANTZ WILL NOT SUPPLY THESE PARTS.

PARTS LIST [DV6400]

POS. NO	VERS. COLOR	PART NO. (FOR EUR)	PART NO. (MJI)	DESCRIPTION		
EXPLODED VIEW PARTS						
A1X	/F1N/S1G	nsp	45AW248140	FRONT PANEL (GOLD)	FRONT ASSY E57M6JD	0VM204450
A1X	/N1B	45AW248010	45AW248010	FRONT PANEL (BLACK)	FRONT ASSY E57M7ED	0VM204417
A1X	/N1S	45AW248210	45AW248210	FRONT PANEL(SILVER)	FRONT ASSY E57M9ED	0VM204418
A1X	/U1B	nsp	45AW248020	FRONT PANEL(BLACK)	FRONT ASSY E57M5UD	0VM204465
A2	GOLD	nsp	45AW063140	ESCUTCHEON	TRAY PANEL E57M6JD	0VM416078
A2	BLACK	45AW063010	45AW063010	ESCUTCHEON	TRAY PANEL E57M7ED	0VM416021
A2	SILVER	45AW063210	45AW063210	ESCUTCHEON	TRAY PANEL E57M9ED	0VM416025
A13		44AW057020	44AW057020	LEG	FOOT(REAR) E5710UD	0VM415007
A14	BLACK, GOLD	44AW057010	44AW057010	LEG	LEG ASSY E57M0UD	0VM415913
A14	SILVER	44AW057210	44AW057210	LEG	LEG ASSY E57M4ED	0VM416056
1B1		44AW304010	44AW304010	MACHA LOADER / MECHA TRAVERSE	DVD MECHA 0838 VCDVM040	N79F0GVM
A15	/F	nsp	*ZZ002390R	PCB ASSY	DVD MAIN CBA UNIT	N79B7GJP
A15	/N	*ZZ002260R	*ZZ002260R	PCB ASSY	DVD MAIN CBA UNIT	N79B1GEP
A15	/S	nsp	*ZZ002440R	PCB ASSY	DVD MAIN CBA UNIT	N79B3GPP
A15	/U	nsp	*ZZ002400R	PCB ASSY	DVD MAIN CBA UNIT	N79B5GUP
A17	/F	nsp	*ZZ002370R	PCB ASSY	AV CBA ASSY / LED CBS ASSY / Switch CBA ASSY	0VSA14688
A17	/N	*ZZ002270R	*ZZ002270R	PCB ASSY	AV CBA ASSY / LED CBS ASSY / Switch CBA ASSY	0VSA14676
A17	/S	nsp	*ZZ002450R	PCB ASSY	AV CBA ASSY / LED CBS ASSY / Switch CBA ASSY	0VSA14647
A17	/U	nsp	*ZZ002380R	PCB ASSY	AV CBA ASSY / LED CBS ASSY / Switch CBA ASSY	0VSA14619
A18		*ZZ002250R	*ZZ002250R	PCB ASSY	FUNCTION CBA ASSY	0VSA14617
A19	/N/S	*ZZ002280R	*ZZ002280R	PCB ASSY	SACD CBA ASSY	0VSA14446
A19	/F/U	nsp	*ZZ002410R	PCB ASSY	SACD CBA ASSY	0VSA14758
▲	AC1001	/N/S	*YC000820R	*YC000820R	MAINS CORD	MAINS CORD PE8B2CG980A-057 WAE0172LW006
▲	AC1001	/F	nsp	*YC000830R	MAINS CORD	MAINS CORD PP8B5PB110AA057 WAJ0172LW009
▲	AC1001	/U	nsp	*YC000840R	MAINS CORD	MAINS CORD A0A0280-007 OR PB8K9F9110A-057 WAC0172LW008
W7102		*YU001360R	*YU001360R	FPC	20P FFC DVD-A PCB TO MAIN	WX1E5732-004
W7151		*YU001370R	*YU001370R	FPC	17P FFC SACD PCB TO MAIN	WX1E57D1-001
W1001		*YU001380R	*YU001380R	FPC	22P FFC AV PCB TO MAIN	WX1E5700-003
W1601	/F/N/U	*YU001390R	*YU001390R	FPC	18P FFC DVD-A PCB TO MAIN	WX1E5700-002
W1601	/S	nsp	*YU001450R	FPC	16P FFC DVD-A PCB TO MAIN	WX1E5700-005
W2002		*YU001400R	*YU001400R	FPC	12P FFC AV PCB TO FNT PCB	WX1E5610-001
W6001		*YU001410R	*YU001410R	FPC	6P FFC OR AWG22#1007 AV PCB TO LED PCB	WX1E57D1-003 OR WX3001A24405
W1603		*YU001420R	*YU001420R	FPC	7P FFC AV PCB TO SACD PCB	WX1E57D1-002
PACKING						
X1		ZK44AW0010	ZK44AW0010	UNIT KIT	REMOTE CONTROLLER RC6400DV	NA638UD
X10	/F	nsp	45AW851110	USER GUIDE	USER GUIDE E57M6JD	0VMN03858
X10	/N	45AW851310	45AW851310	USER GUIDE	USER GUIDE E57M7ED	0VMN03869
X10	/S	nsp	45AW851350	USER GUIDE	USER GUIDE E57M8PD	0VMN03873
X10	/U	nsp	45AW851250	USER GUIDE	USER GUIDE E57M5UD	0VMN03870
NOT STANDARD SPARE PARTS						
A16	GOLD	nsp	44AW257110	LID	TOP COVER GOLD E57E2ED	0VM306454
A16	BLACK	nsp	44AW257010	LID	TOP COVER BLACK E5600UD	0VM101038
A16	SILVER	nsp	44AW257210	LID	TOP COVER SILVER E56A0UD	0VM305312C
S1	/F/N/U	nsp	45AW801010	CARTON BOX	GIFT BOX CARTON E57M7ED	0VM306632
S1	/S	nsp	45AW801020	CARTON BOX	GIFT BOX CARTON E57M8PD	0VM306702
S2		nsp	45AW809010	CUSHION	CUSHION (UK) E57M5UD	0VM101327

NOTE : "nsp" PART IS LISTED FOR REFERENCE ONLY, MARANTZ WILL NOT SUPPLY THESE PARTS.

PARTS LIST [DV6400]

POS. NO	VERS. COLOR	PART NO. (FOR EUR)	PART NO. (MJI)	DESCRIPTION		
ELECTRICAL PARTS LIST						
AV CBA						
▲	C1001	/F/U	nsp	*DF100390R	FILM CAP.	0.01µF/250V K OR 0.01µF/275V K OR 0.01µF/250V M CT2E103DC011 OR CT2E103HJE05 OR CT2E103MS037
▲	C1001	/N/S	*DF100360R	*DF100360R	FILM CAP.	0.047µF/250V K OR M CT2E473DC011 OR CT2E473MS037
▲	C1006	/F/U	nsp	*DK100860R	CERAMIC CAP.	2200pF/250V OR 2200pF/125V CCD2EMA0E222 OR CCG2EMA0F222 OR CCG2BMA0E222
▲	C1006	/N/S	*DK100860R	*DK100850R	CERAMIC CAP.	SAFETY CAP. 2200pF/250V CCN2EMA0E222 OR CA2E222MR049
▲	F1001	/F/U	nsp	*FS001140R	FUSE	FUSE 1A/250V PAGA20CW3102 OR PAGG20CAG102
▲	F1001	/N/S	*FS001120R	*FS001120R	FUSE	FUSE T1.6AL/250V PAGC20BW3162 OR 1790994
	IC1204		*YJ002710R	*YJ002710R	OPT. CONNECTOR	OPTIC TRANS.MODULE GP1FA513TZ JWHHA00SH005
	JK1202		*YT003420R	*YT003420R	TERMINAL	CINCH JACK(BLACK) MSP-251V-10 GILT JXRL010LY090
	JK1401		*YT003380R	*YT003380R	TERMINAL	S TYPE JACK MDC-050V-2.4 JXEL040LY001
	JK1405	/F	nsp	*YT003560R	TERMINAL	D TERMINAL 14P DT-0102*001 JBDTJ14JD002
	JK6101	/N	*YT003390R	*YT003390R	TERMINAL	CINCH JACK 21P RGB AJ-2050*040 JXGL210JD002
	JK6102	/N/S/U	*YT003430R	*YT003430R	TERMINAL	CINCH JACK 3PIN MSD-243V-19 GILT JXRL030LY092
	JK6103		*YT003440R	*YT003440R	TERMINAL	CINCH JACK 3PIN MSD-243V-31 GILT JXRL030LY089
▲	L1001	/F/U	nsp	*FN000200R	FILTER	LINE FILTER 20MH SA-00911 LLBG00ZSA003
▲	L1001	/N/S	*FN000190R	*FN000190R	FILTER	50MH LF-4Z-E503/LF-4D-E503/ TLF14CB5630R2 LLBG00ZKQ008 OR LLBG00ZKQ009 OR LLBG00ZTU022
▲	SA1001		*HV000050R	*HV000050R	VARISTOR	PVR-10D471KB/CNR-10D471K NVQZ10D471KB OR NVQZR10D471K
▲	T1001	/F/U	nsp	*TP000070R	TRANSF.	PULSE TRANS CSA-SW0215B LTT00CPSA132
▲	T1001	/N	*TS002050R	*TS002050R	TRANSF.	MAINS TRANSFORMER CSA-SW0215C LTT00EPSA141
▲	T1001	/S	nsp	*TS002070R	TRANSF.	MAINS TRANSFORMER CSA-SW0308A LTT00ZPSA144
SACD CBA						
	JK7101		*YT003450R	*YT003450R	TERMINAL	CINCH JACK 6PIN MSD-246V-38 GILT JXRL060LY091

NOTE : *nsp* PART IS LISTED FOR REFERENCE ONLY, MARANTZ WILL NOT SUPPLY THESE PARTS.