

# Service Manual

DV6600 /N1B/N1S

Super Audio CD / DVD Player

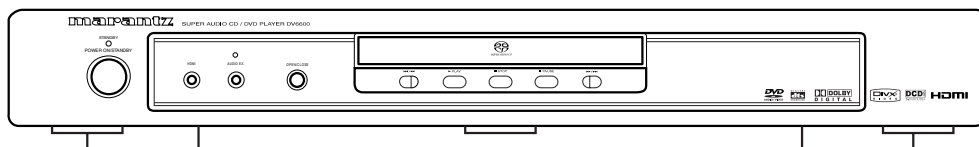

## TABLE OF CONTENTS

| SECTION  | PAGE   |
|--|--------|
| TECHNICAL SPECIFICATIONS.....                    | 1-1-1  |
| SERVICE HINTS AND TOOLS.....                     | 1-2-1  |
| WARNING AND LASER SAFETY INSTRUCTIONS .....      | 1-2-2  |
| LASER BEAM SAFETY PRECAUTIONS.....               | 1-2-3  |
| IMPORTANT SAFETY PRECAUTIONS .....               | 1-3-1  |
| STANDARD NOTES FOR SERVICING .....               | 1-4-1  |
| CABINET DISASSEMBLY INSTRUCTIONS .....           | 1-5-1  |
| HOW TO INITIALIZE THE DVD PLAYER .....           | 1-6-1  |
| FIRMWARE RENEWAL MODE.....                       | 1-7-1  |
| TROUBLESHOOTING.....                             | 1-8-1  |
| BLOCK DIAGRAMS .....                             | 1-9-1  |
| SCHEMATIC DIAGRAMS / CBA'S AND TEST POINTS ..... | 1-10-1 |
| WAVEFORMS .....                                  | 1-11-1 |
| WIRING DIAGRAM .....                             | 1-12-1 |
| IC PIN FUNCTION DESCRIPTIONS .....               | 1-13-1 |
| LEAD IDENTIFICATIONS.....                        | 1-14-1 |
| EXPLODED VIEWS .....                             | 1-15-1 |
| PARTS LIST .....                                 | 1-16-1 |

Please use this service manual with referring to the user guide ( D.F.U. ) without fail.  
修理の際は、必ず取扱説明書を準備し操作方法を確認の上作業を行ってください。

# marantz®

## DV6600

Part no. 90M38BW855010  
First Issue 2005.09  
MZ

DV6600

## MARANTZ DESIGN AND SERVICE

Using superior design and selected high grade components, **MARANTZ** company has created the ultimate in stereo sound. Only original **MARANTZ** parts can insure that your **MARANTZ** product will continue to perform to the specifications for which it is famous.

Parts for your **MARANTZ** equipment are generally available to our National Marantz Subsidiary or Agent.

### ORDERING PARTS :

Parts can be ordered either by mail or by Fax.. In both cases, the correct part number has to be specified.

The following information must be supplied to eliminate delays in processing your order :

1. Complete address
2. Complete part numbers and quantities required
3. Description of parts
4. Model number for which part is required
5. Way of shipment
6. Signature : any order form or Fax. must be signed, otherwise such part order will be considered as null and void.

#### USA

**MARANTZ AMERICA, INC**  
1100 MAPLEWOOD DRIVE  
ITASCA, IL. 60143  
USA  
PHONE : 630 - 741 - 0300  
FAX : 630 - 741 - 0301

#### EUROPE / TRADING

**MARANTZ EUROPE B.V.**  
P. O. BOX 8744, BUILDING SILVERPOINT  
BEEMDSTRAAT 11, 5653 MA EINDHOVEN  
THE NETHERLANDS  
PHONE : +31 - 40 - 2507844  
FAX : +31 - 40 - 2507860

#### CANADA

**MARANTZ CANADA INC.**  
5-505 APPLE CREEK BLVD.  
MARKHAM, ONTARIO L3R 5B1  
CANADA  
PHONE : 905 - 415 - 9292  
FAX : 905 - 475 - 4159

#### AUSTRALIA

**QualiFi Pty Ltd,**  
24 LIONEL ROAD,  
MT. WAVERLEY VIC 3149  
AUSTRALIA  
PHONE : +61 - (0)3 - 9543 - 1522  
FAX : +61 - (0)3 - 9543 - 3677

#### THAILAND

**MRZ STANDARD CO., LTD**  
746 - 754 MAHACHAI ROAD.,  
WANGBURAPAPIROM, PHRANAKORN,  
BANGKOK, 10200 THAILAND  
PHONE : +66 - 2 - 222 9181  
FAX : +66 - 2 - 224 6795

#### SINGAPORE

**WO KEE HONG DISTRIBUTION PTE LTD**  
No.1 JALAN KILANG TIMOR  
#08-03 PACIFIC TECH CENTRE  
SINGAPORE 159303  
PHONE : +65 6376 0338  
FAX : +65 6376 0166

#### NEW ZEALAND

**WILDASH AUDIO SYSTEMS NZ**  
14 MALVERN ROAD MT ALBERT  
AUCKLAND NEW ZEALAND  
PHONE : +64 - 9 - 8451958  
FAX : +64 - 9 - 8463554

#### TAIWAN

**PAI-YUING CO., LTD.**  
6 TH FL NO, 148 SUNG KIANG ROAD,  
TAIPEI, 10429, TAIWAN R.O.C.  
PHONE : +886 - 2 - 25221304  
FAX : +886 - 2 - 25630415

#### MALAYSIA

**WO KEE HONG ELECTRONICS SDN. BHD.**  
2ND FLOOR BANGUNAN INFINITE CENTRE  
LOT 1, JALAN 13/6, 46200 PETALING JAYA  
SELANGOR DARUL EHSAN, MALAYSIA  
PHONE : +60 - 3 - 7954 8088  
FAX : +60 - 3 - 7954 7088

#### JAPAN *Technical*

**D&M Holdings Inc.**  
35- 1, 7- CHOME, SAGAMIONO  
SAGAMIHARA - SHI, KANAGAWA  
JAPAN 228-8505  
PHONE : +81 42 748 1013  
FAX : +81 42 741 9190

株式会社 ティーアンドエムホールディングス

本 社 〒228-8505  
神奈川県相模原市相模大野7-35-1

#### KOREA

**MARANTZ KOREA CO., LTD.**  
ROOM 604, ELECTRO OFFICE, 16-58,  
HANGGANG-RO 3GA, YONGSAN-KU,  
SEOUL, 140-013, KOREA  
PHONE : +82 - 2 - 323 - 2155  
FAX : +82 - 2 - 323 - 2154

### SHOCK, FIRE HAZARD SERVICE TEST :

**CAUTION :** After servicing this appliance and prior to returning to customer, measure the resistance between either primary AC cord connector pins ( with unit NOT connected to AC mains and its Power switch ON ), and the face or Front Panel of product and controls and chassis bottom.

Any resistance measurement less than 1 Megohms should cause unit to be repaired or corrected before AC power is applied, and verified before it is return to the user/customer.

Ref. UL Standard No. 1492.

In case of difficulties, do not hesitate to contact the Technical Department at above mentioned address.

# TECHNICAL SPECIFICATIONS

## SPECIFICATIONS

### SIGNAL SYSTEM

PAL colour

### APPLICABLE DISCS

- (1) DVD-Video/DVD-Audio Discs  
1-layer 12cm single-sided discs, 2-layer 12cm single-sided discs, 2-layer 12cm double-sided discs (1 layer per side)  
1-layer 8cm single-sided discs, 2-layer 8cm single-sided discs, 2-layer 8cm double-sided discs (1 layer per side)
- (2) Super Audio CD
- (3) DVD-R/DVD-RW
- (4) Compact discs (Audio CD, Video CD)  
12cm discs, 8cm discs
- (5) CD-R/CD-RW

### S-VIDEO OUTPUT

Y output level: 1Vp-p (75Ω/ohms)  
C output level: 0.3Vp-p  
Output connectors: S connectors, 1 set

### VIDEO OUTPUT

Output level: 1Vp-p (75Ω/ohms)  
Output connector: Pin jacks, 1 set

### COMPONENT OUTPUT

Y output level: 1Vp-p (75Ω/ohms)  
C<sub>B</sub>/P<sub>B</sub> output level: 0.7Vp-p (75Ω/ohms)  
C<sub>R</sub>/P<sub>R</sub> output level: 0.7Vp-p (75Ω/ohms)  
Output connector: Pin jacks, 1 set

### HDMI OUTPUT

HDMI terminal, 1 set

### AUDIO/VIDEO

21-pin scart jack

### AUDIO OUTPUT

Output level: 2Vrms  
2 channel (L, R) output connector: Pin jack, 1 set  
Multi channel (FL, FR, C, SL, SR, SW) output connector :  
Pin jack, 1 set.

### AUDIO OUTPUT PROPERTIES

- (1) Frequency response
  - 1 DVDs (linear PCM) : 4Hz to 22kHz (48kHz sampling)
  - : 4Hz to 44kHz (96kHz sampling)
  - : 4Hz to 88kHz (192kHz sampling)
  - 2 CDs : 4Hz to 20kHz
  - 3 Super Audio CD : 4Hz to 100kHz
- (2) S/N ratio : 115dB
- (3) Total harmonic distortion : 1kHz CD: 0.0045%
- (4) Dynamic range : DVD: 100dB  
CD: 98dB

### DIGITAL AUDIO OUTPUT

Optical digital output: Optical jack, 1 set  
Coaxial digital output: Pin jack, 1 set

### POWER SUPPLY

AC 200-240V, 50Hz

### POWER CONSUMPTION

15 W

### MAXIMUM EXTERNAL DIMENSIONS

440 (width) x 65 (height) x 313 (depth) mm

### MASS

2.5 kg (5.5 lbs)

### REMOTE CONTROL UNIT

RC6600DV  
Infrared pulse type  
Supply: DC 3V, 2 R6P/AA batteries

## PIN CONNECTION (A/V EURO CONNECTOR)

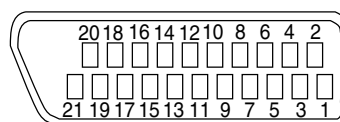

### Contacts, signal levels and impedances

|                   |                                   |  |
|-------------------|-----------------------------------|--|
| <i>Contact 1</i>  | Audio Output (Right):             | 2.0Vrms/ 1kΩ                                 |
| <i>Contact 3</i>  | Audio Output (Left):              | 2.0Vrms/ 1kΩ                                 |
| <i>Contact 4</i>  | Audio, Ground                     |  |
| <i>Contact 5</i>  | RGB, Ground (Blue)                |  |
| <i>Contact 7</i>  | RGB Output (Blue):                | 0.7Vp-p/75Ω                                  |
| <i>Contact 8</i>  | Function Select Switching Control |  |
|                   |                                   | L: 0.0~2.0V DC<br>Power Off                  |
|                   |                                   | M: 4.5~7.0V DC<br>Wide-Screen Mode<br>(16:9) |
|                   |                                   | H: 9.5~12.0V DC<br>Normal Mode (4:3)         |
| <i>Contact 9</i>  | RGB, Ground (Green)               |  |
| <i>Contact 11</i> | RGB Output (Green):               | 0.7Vp-p/75Ω                                  |
| <i>Contact 13</i> | RGB, Ground (Red)                 |  |
| <i>Contact 14</i> | RGB Switching Control, Ground     |  |
| <i>Contact 15</i> | RGB Output (Red):                 | 0.7Vp-p/75Ω                                  |
| <i>Contact 16</i> | RGB Switching Control             |  |
|                   | H: 3.3V DC                        | RGB Mode                                     |
| <i>Contact 17</i> | Video Output Signal, Ground       |  |
| <i>Contact 18</i> | Video Input Signal, Ground        |  |
| <i>Contact 19</i> | Video Output (CVBS):              | 1.0Vp-p/75Ω                                  |
| <i>Contact 21</i> | Common Ground (shielding)         |  |

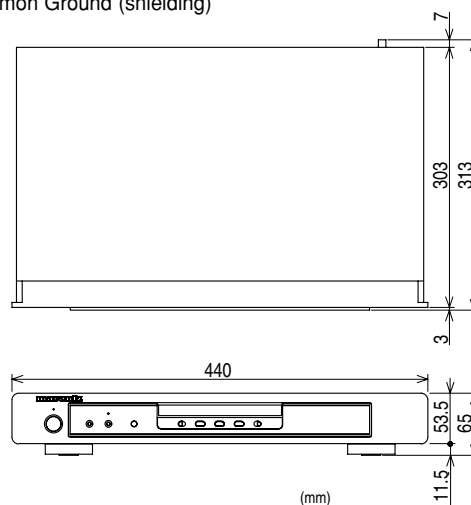

## ABOUT THE DISCS

### Playable Discs

| Playable discs                           | Mark (logo)         | Region code | Recorded signals   | Disc size     | Disc types |
|--|---------------------|-------------|--|---------------|------------|
| DVD-Audio<br>* 2, 3, 5                   |                     | —           | Digital audio + Digital video (MPEG2)                          | 12 cm or 8 cm |            |
| DVD-Video<br>* 1, 2, 3, 5                |                     |             |  |               |            |
| DVD-RW<br>DVD-R<br>* 1, 3, 4, 5, 6, 7, 8 | <br>                | or          | Digital video (MPEG2)<br>DivX®                                 | 12 cm or 8 cm |            |
| Video CD<br>* 1, 3, 5, 9                 | <br>                | —           | Sound and Pictures   |               |            |
| Super Audio CD                           | <br>STEREO Multi-ch | —           | Digital audio  |               |            |
| Audio CD<br>* 4, 5                       |                     | —           | Digital audio  | 12 cm or 8 cm |            |
| CD-RW<br>CD-R<br>* 4, 5, 7, 8, 9         | <br>                | —           | Digital audio MP3<br>WMA*10<br>Digital picture (JPEG)<br>DivX® |               |            |
| Picture CD                               |                     | —           | JPEG   | 12 cm         |            |

#### If you cannot play back a disc which bears one of the marks above, check the following notes.

- \*1: This player conforms to the PAL colour system. Also you can play discs recorded with the NTSC system via a PAL system TV set.
- \*2: Certain DVD-Video discs do not operate as described in this manual due to the intentions of the disc's producers.
- \*3: Scratched or stained discs may not be played back.
- \*4: Some discs cannot be played back because of incompatible recording conditions, characteristics of the recorder or special properties of discs.
- \*5: You can play back discs which bear the marks above. If you use nonstandardized discs, this unit may not play them back. Even if they are played back, the sound or video quality will be compromised.
- \*6: Only the discs recorded in the video format or Video Recording format, and finalized can be played back. Unfinalized discs cannot be played back. Depending on the recording status of a disc, the disc may not be played back at all or normally (the picture or sound may be distorted, etc.).
- \*7: If there is too much recordable space left on a disc (the used portion is less than 55mm across), it may not play back properly.
- \*8: Do not glue paper or put stickers on to the disc. These may damage the disc, and the unit may not read it correctly.
- \*9: This unit conforms to ver.1.1 and ver.2.0 of Video CD standard with PBC function.  
*Ver.1.1 (without PBC function):* You can enjoy playback picture as well as music CD.  
*Ver.2.0 (with PBC function):* While using a Video CD with PBC function, "Pbc" appears on the screen and the display.  
**NOTE:** When playing Video CDs with PBC function, some operations (e.g., track search and repeat tracks) cannot be performed. Cancel PBC function temporarily to perform those operations (refer to page 17).

**What is PBC?** "PBC" stands for Playback Control.  
You can play interactive software using menu screens. Refer to instructions in the Video CD.

- \*10: This player cannot play the disc contents protected by Windows Media Digital Rights Management (DRM).  
**NOTE:** This player cannot play the DVD-RW discs that supports CPRM (Content Protection for Recordable Media).  
 This player cannot play the DVD-R discs recorded in VR mode (Video Recording format).

- **NEVER play back the following discs. Otherwise, malfunction may result!**  
 DVD-RAM / CD-I / Photo CD / DVD with region codes other than 2 or ALL / DVD-ROM for personal computers / CD-ROM for personal computers
- Any other discs without compatibility indications

#### CAUTION:

- Use caution not to pinch your finger in the disc slot.
- Be sure to remove a disc and unplug the AC power cord from the outlet before carrying the DVD player.

# SERVICE HINTS AND TOOLS

## SERVICE HINTS

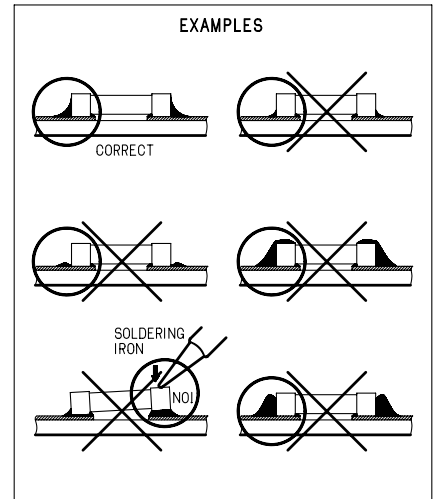
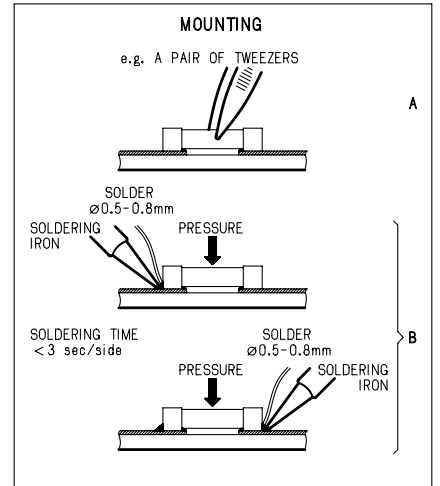
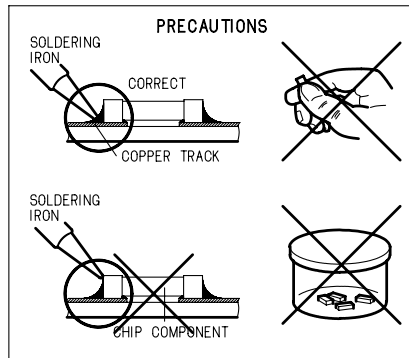
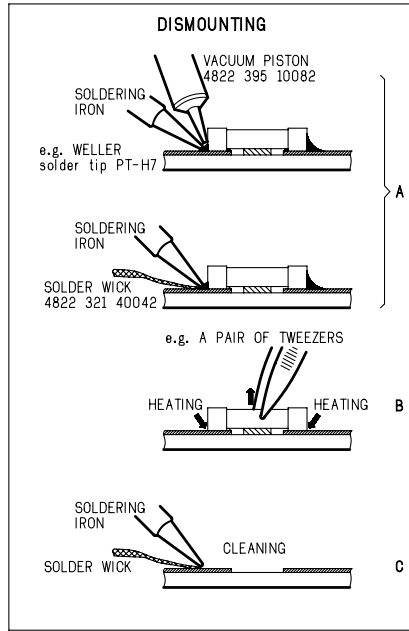
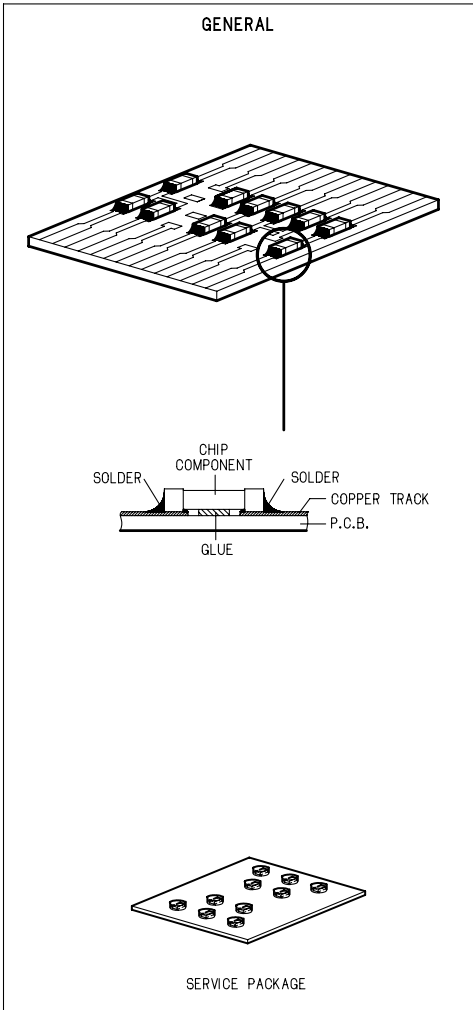

## SERVICE TOOLS

|   |                |
|---|----------------|
| Audio signals disc  | 4822 397 30184 |
| Disc without errors (SBC444)+                               |                |
| Disc with DO errors, black spots and fingerprints (SBC444A) | 4822 397 30245 |
| Disc (65 min 1kHz) without no pause                         | 4822 397 30155 |
| Max. diameter disc (58.0 mm)                                | 4822 397 60141 |
| Torx screwdrivers   |                |
| Set (straight)  | 4822 395 50145 |
| Set (square)  | 4822 395 50132 |
| 13th order filter   | 4822 395 30204 |
| DVD test disc (PAL)   | 4822 397 10131 |
| DVD test disc (NTSC) ALMEDIO                                | TDV-540        |

# WARNING AND LASER SAFETY INSTRUCTIONS

## **(GB)** WARNING

All ICs and many other semi-conductors are susceptible to electrostatic discharges (ESD). Careless handling during repair can reduce life drastically.  
When repairing, make sure that you are connected with the same potential as the mass of the set via a wrist wrap with resistance.  
Keep components and tools also at this potential.



## **(NL)** WAARSCHUWING

Alle IC's en vele andere halfgeleiders zijn gevoelig voor elektrostatische ontladingen (ESD).  
Onzorgvuldig behandelen tijdens reparatie kan de levensduur drastisch doen verminderen.  
Zorg ervoor dat u tijdens reparatie via een polsband met weerstand verbonden bent met hetzelfde potentiaal als de massa van het apparaat.  
Houd componenten en hulpmiddelen ook op hetzelfde potentiaal.

## **(F)** ATTENTION

Tous les IC et beaucoup d'autres semi-conducteurs sont sensibles aux décharges statiques (ESD).  
Leur longévité pourrait être considérablement écourtée par le fait qu'aucune précaution n'est prise à leur manipulation.  
Lors de réparations, s'assurer de bien être relié au même potentiel que la masse de l'appareil et enfiler le bracelet serti d'une résistance de sécurité.  
Veiller à ce que les composants ainsi que les outils que l'on utilise soient également à ce potentiel.

## **(D)** WARNUNG

Alle IC und viele andere Halbleiter sind empfindlich gegen elektrostatische Entladungen (ESD).  
Unvorsichtige Behandlung bei der Reparatur kann die Lebensdauer drastisch vermindern.  
Sorgen sie dafür, das Sie im Reparaturfall über ein Pulsarmband mit Widerstand mit dem Massepotential des Gerätes verbunden sind.  
Halten Sie Bauteile und Hilfsmittel ebenfalls auf diesem Potential.

## **(I)** AVVERTIMENTO

Tutti IC e parecchi semi-conduttori sono sensibili alle scariche statiche (ESD).  
La loro longevita potrebbe essere fortemente ridatta in caso di non osservazione della piu grande cauzione alla loro manipolazione.  
Durante le riparazioni occorre quindi essere collegato allo stesso potenziale che quello della massa dell'apparecchio tramite un braccialetto a resistenza.  
Assicurarsi che i componenti e anche gli utensili con quali si lavora siano anche a questo potenziale.

## **(GB)**

Safety regulations require that the set be restored to its original condition and that parts which are identical with those specified be used.

## **(NL)**

Veiligheidsbepalingen vereisen, dat het apparaat in zijn oorspronkelijke toestand wordt terug gebracht en dat onderdelen, identiek aan de gespecificeerde worden toegepast.

"Pour votre sécurité, ces documents doivent être utilisés par des spécialistes agréés, seuls habilités à réparer votre appareil en panne."

## **(F)**

Les normes de sécurité exigent que l'appareil soit remis à l'état d'origine et que soient utilisées les pièces de rechange identiques à celles spécifiées.

## **(D)**

Bei jeder Reparatur sind die geltenden Sicherheitsvorschriften zu beachten. Der Originalzustand des Gerats darf nicht verändert werden. Für Reparaturen sind Original-Ersatzteile zu verwenden.

## **(I)**

Le norme di sicurezza esigono che l'apparecchio venga rimesso nelle condizioni originali e che siano utilizzati pezzi di ricambio identici a quelli specificati.

## LASER SAFETY

This unit employs a laser. Only a qualified service person should remove the cover or attempt to service this device, due to possible eye injury.



**USE OF CONTROLS OR ADJUSTMENTS OR PERFORMANCE OF PROCEDURE OTHER THAN THOSE SPECIFIED HEREIN MAY RESULT IN HAZARDOUS RADIATION EXPOSURE.**

**AVOID DIRECT EXPOSURE TO BEAM**

## WARNING

**The use of optical instruments with this product will increase eye hazard.  
Repair handling should take place as much as possible with a disc loaded inside the player**

## WARNING LOCATION: INSIDE ON LASER COVERSIELD

**CAUTION** VISIBLE AND INVISIBLE LASER RADIATION WHEN OPEN AVOID EXPOSURE TO BEAM  
**ADVARSEL** SYNLIG OG USYNLIG LASERSTRÅLING VED ÅBNING UNDGÅ UDSÆTTELSE FOR STRÅLING  
**ADVARSEL** SYNLIG OG USYNLIG LASERSTRÅLING NÅR DEKSEL Å PNES UNNGÅ EKSPONERING FOR STRÅLEN  
**VARNING** SYNLIG OCH OSYNLIG LASERSTRÅLNING NÅR DENNA DEL ÅR ÖPPNAD BETRAKTA EJ STRÅLEN  
**VARO!** AVATT AESSA OLET ALTTIINA NÄKYVÄLLE JA NÄKYMÄTTÖMÄLLE LASER SÄTEILYLLE. ÄLÄ KATSO SÄTEESEEN  
**VORSICHT** SICHTBARE UND UNSICHTBARE LASERSTRAHLUNG WENN ABDECKUNG GEÖFFNET NICHT DEM STRAHL AUSSETZEN  
**DANGER** VISIBLE AND INVISIBLE LASER RADIATION WHEN OPEN AVOID DIRECT EXPOSURE TO BEAM  
**ATTENTION** RAYONNEMENT LASER VISIBLE ET INVISIBLE EN CAS D'OUVERTURE EXPOSITION DANGEREUSE AU FAISCEAU

# LASER BEAM SAFETY PRECAUTIONS

This DVD player uses a pickup that emits a laser beam.

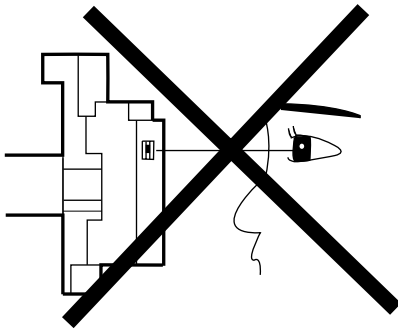

Do not look directly at the laser beam coming from the pickup or allow it to strike against your skin.

The laser beam is emitted from the location shown in the figure. When checking the laser diode, be sure to keep your eyes at least 30 cm away from the pickup lens when the diode is turned on. Do not look directly at the laser beam.

**CAUTION:** Use of controls and adjustments, or doing procedures other than those specified herein, may result in hazardous radiation exposure.

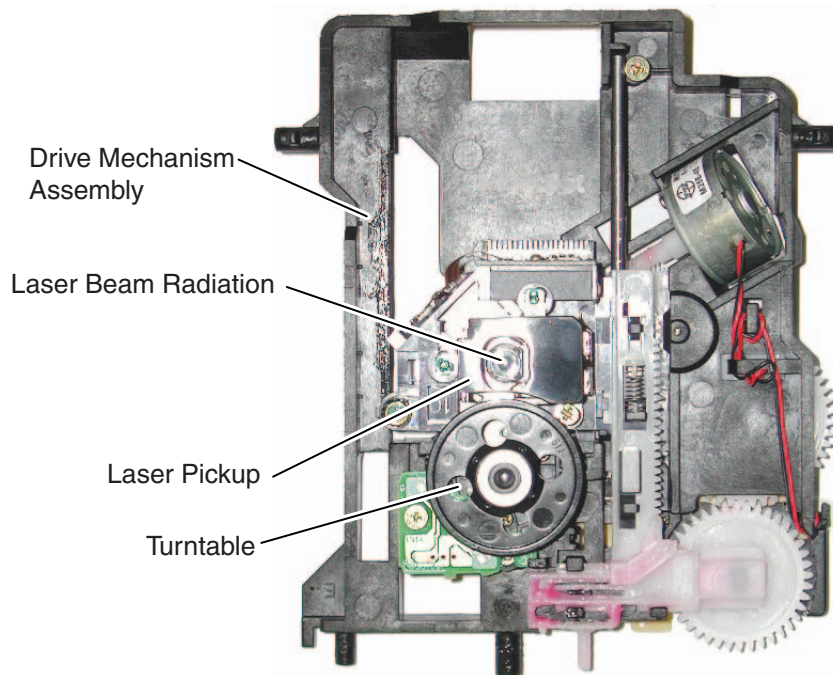

CAUTION - CLASS 1M LASER RADIATION WHEN OPEN. DO NOT VIEW DIRECTLY WITH OPTICAL INSTRUMENTS

**Location: Top of DVD mechanism.**

# IMPORTANT SAFETY PRECAUTIONS

## Product Safety Notice

Some electrical and mechanical parts have special safety-related characteristics which are often not evident from visual inspection, nor can the protection they give necessarily be obtained by replacing them with components rated for higher voltage, wattage, etc. Parts that have special safety characteristics are identified by a  $\triangle$  on schematics and in parts lists. Use of a substitute replacement that does not have the same safety characteristics as the recommended replacement part might create shock, fire, and/or other hazards. The Product's Safety is under review continuously and new instructions are issued whenever appropriate. Prior to shipment from the factory, our products are carefully inspected to confirm with the recognized product safety and electrical codes of the countries in which they are to be sold. However, in order to maintain such compliance, it is equally important to implement the following precautions when a set is being serviced.

## Precautions during Servicing

- A. Parts identified by the  $\triangle$  symbol are critical for safety. Replace only with part number specified.
- B. In addition to safety, other parts and assemblies are specified for conformance with regulations applying to spurious radiation. These must also be replaced only with specified replacements.  
Examples: RF converters, RF cables, noise blocking capacitors, and noise blocking filters, etc.
- C. Use specified internal wiring. Note especially:
  - 1) Wires covered with PVC tubing
  - 2) Double insulated wires
  - 3) High voltage leads
- D. Use specified insulating materials for hazardous live parts. Note especially:
  - 1) Insulation tape
  - 2) PVC tubing
  - 3) Spacers
  - 4) Insulators for transistors
- E. When replacing AC primary side components (transformers, power cord, etc.), wrap ends of wires securely about the terminals before soldering.
- F. Observe that the wires do not contact heat producing parts (heatsinks, oxide metal film resistors, fusible resistors, etc.).
- G. Check that replaced wires do not contact sharp edges or pointed parts.
- H. When a power cord has been replaced, check that 5 - 6 kg of force in any direction will not loosen it.
- I. Also check areas surrounding repaired locations.
- J. Use care that foreign objects (screws, solder droplets, etc.) do not remain inside the set.
- K. Crimp type wire connector  
The power transformer uses crimp type connectors which connect the power cord and the primary side of the transformer. When replacing the transformer, follow these steps carefully and precisely to prevent shock hazards.  
Replacement procedure
  - 1) Remove the old connector by cutting the wires at a point close to the connector.  
**Important:** Do not re-use a connector. (Discard it.)
  - 2) Strip about 15 mm of the insulation from the ends of the wires. If the wires are stranded, twist the strands to avoid frayed conductors.
  - 3) Align the lengths of the wires to be connected. Insert the wires fully into the connector.
  - 4) Use a crimping tool to crimp the metal sleeve at its center. Be sure to crimp fully to the complete closure of the tool.
- L. When connecting or disconnecting the internal connectors, first, disconnect the AC plug from the AC outlet.



# Safety Check after Servicing

Examine the area surrounding the repaired location for damage or deterioration. Observe that screws, parts, and wires have been returned to their original positions. Afterwards, do the following tests and confirm the specified values to verify compliance with safety standards.

## 1. Clearance Distance

When replacing primary circuit components, confirm specified clearance distance (d) and (d') between soldered terminals, and between terminals and surrounding metallic parts. (See Fig. 1)

**Table 1 : Ratings for selected area**

| AC Line Voltage | Clearance Distance (d), (d')                      |
|-----------------|---|
| 200 to 240 V    | $\geq 3 \text{ mm}(d)$<br>$\geq 6 \text{ mm}(d')$ |

**Note:** This table is unofficial and for reference only. Be sure to confirm the precise values.

## 2. Leakage Current Test

Confirm the specified (or lower) leakage current between B (earth ground, power cord plug prongs) and externally exposed accessible parts (RF terminals, antenna terminals, video and audio input and output terminals, microphone jacks, earphone jacks, etc.) is lower than or equal to the specified value in the table below.

### Measuring Method (Power ON) :

Insert load Z between B (earth ground, power cord plug prongs) and exposed accessible parts. Use an AC voltmeter to measure across the terminals of load Z. See Fig. 2 and the following table.

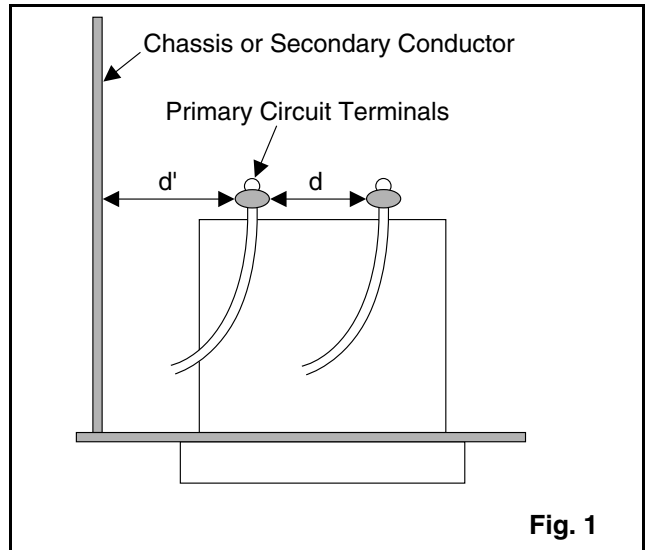

**Fig. 1**

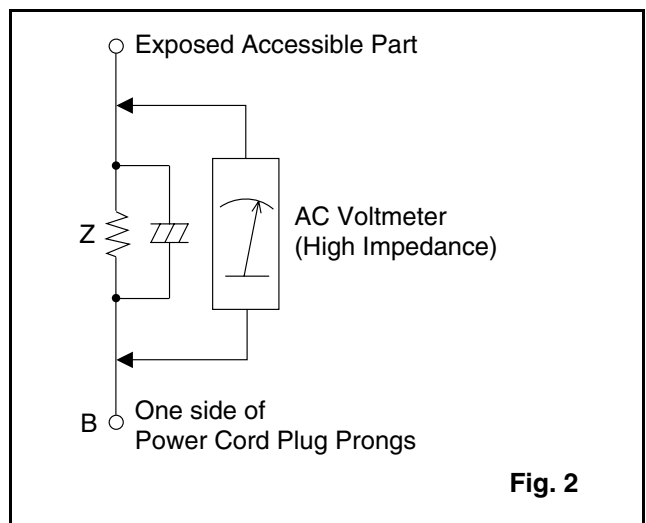

**Fig. 2**

**Table 2: Leakage current ratings for selected areas**

| AC Line Voltage | Load Z                             | Leakage Current (i)   | One side of power cord plug prongs (B) to: |
|-----------------|------------------------------------|---|--|
| 200 to 240 V    | 2kΩ RES.<br>Connected in parallel  | $i \leq 0.7 \text{ mA AC Peak}$<br>$i \leq 2 \text{ mA DC}$ | RF or<br>Antenna terminals                 |
|                 | 50kΩ RES.<br>Connected in parallel | $i \leq 0.7 \text{ mA AC Peak}$<br>$i \leq 2 \text{ mA DC}$ | A/V Input, Output                          |

**Note:** This table is unofficial and for reference only. Be sure to confirm the precise values.

# STANDARD NOTES FOR SERVICING

## Circuit Board Indications

1. The output pin of the 3 pin Regulator ICs is indicated as shown.

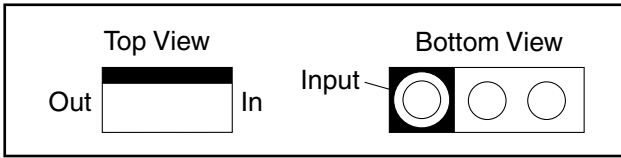

2. For other ICs, pin 1 and every fifth pin are indicated as shown.

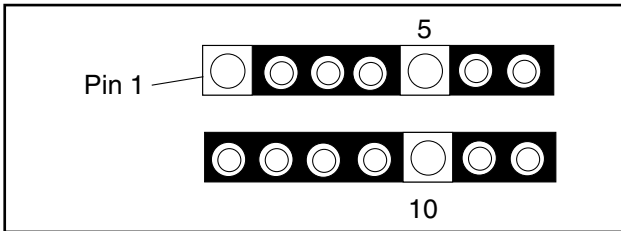

3. The 1st pin of every male connector is indicated as shown.

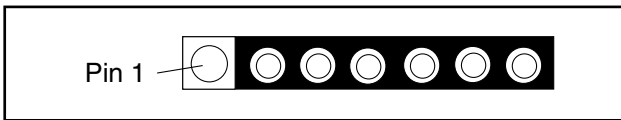

## Instructions for Connectors

1. When you connect or disconnect the FFC (Flexible Foil Connector) cable, be sure to first disconnect the AC cord.
2. FFC (Flexible Foil Connector) cable should be inserted parallel into the connector, not at an angle.

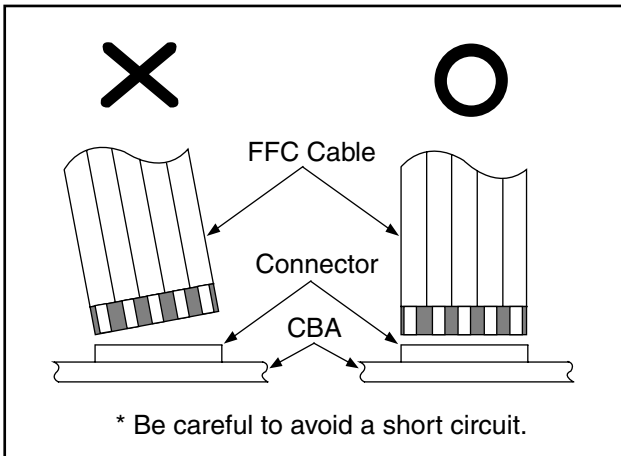

## Pb (Lead) Free Solder

When soldering, be sure to use the Pb free solder.

## How to Remove / Install Flat Pack-IC

### 1. Removal

With Hot-Air Flat Pack-IC Desoldering Machine:

1. Prepare the hot-air flat pack-IC desoldering machine, then apply hot air to the Flat Pack-IC (about 5 to 6 seconds). (Fig. S-1-1)

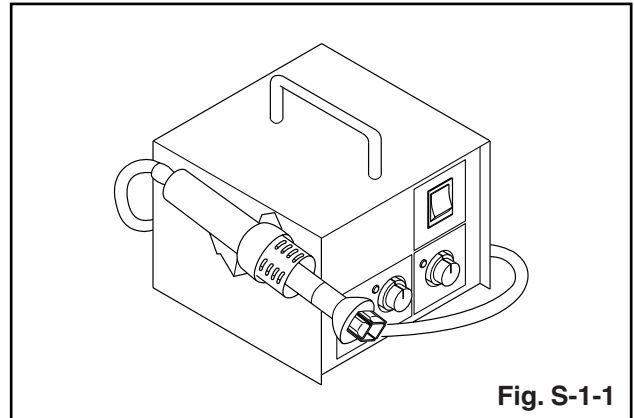

Fig. S-1-1

2. Remove the flat pack-IC with tweezers while applying the hot air.
3. Bottom of the flat pack-IC is fixed with glue to the CBA; when removing entire flat pack-IC, first apply soldering iron to center of the flat pack-IC and heat up. Then remove (glue will be melted). (Fig. S-1-6)
4. Release the flat pack-IC from the CBA using tweezers. (Fig. S-1-6)

### CAUTION:

1. The Flat Pack-IC shape may differ by models. Use an appropriate hot-air flat pack-IC desoldering machine, whose shape matches that of the Flat Pack-IC.
2. Do not supply hot air to the chip parts around the flat pack-IC for over 6 seconds because damage to the chip parts may occur. Put masking tape around the flat pack-IC to protect other parts from damage. (Fig. S-1-2)

3. The flat pack-IC on the CBA is affixed with glue, so be careful not to break or damage the foil of each pin or the solder lands under the IC when removing it.

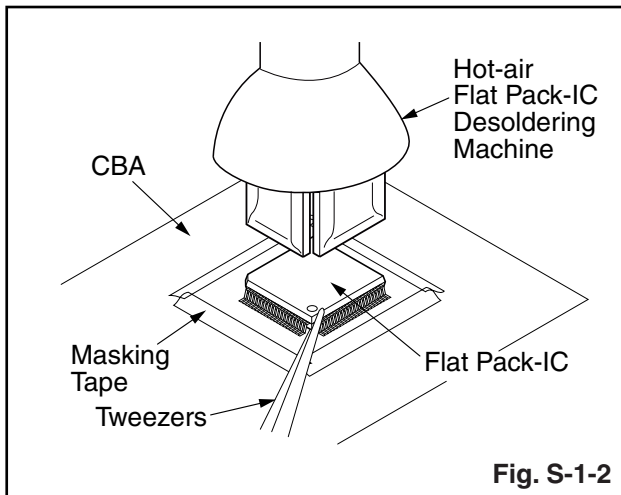

#### With Soldering Iron:

1. Using desoldering braid, remove the solder from all pins of the flat pack-IC. When you use solder flux which is applied to all pins of the flat pack-IC, you can remove it easily. (Fig. S-1-3)

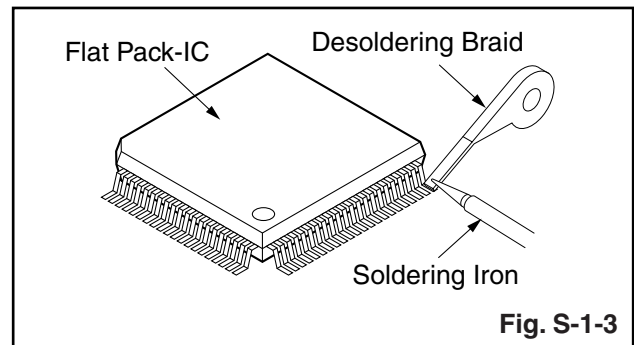

2. Lift each lead of the flat pack-IC upward one by one, using a sharp pin or wire to which solder will not adhere (iron wire). When heating the pins, use a fine tip soldering iron or a hot air desoldering machine. (Fig. S-1-4)

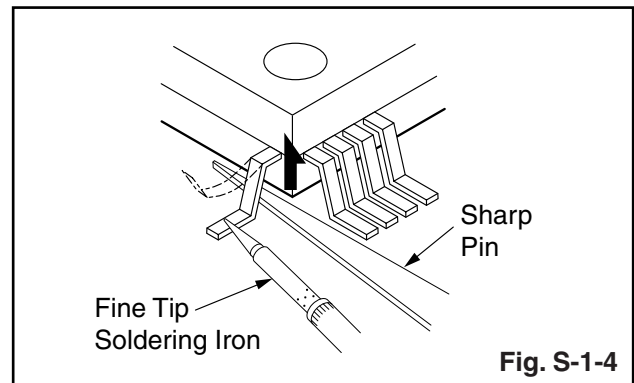

3. Bottom of the flat pack-IC is fixed with glue to the CBA; when removing entire flat pack-IC, first apply soldering iron to center of the flat pack-IC and heat up. Then remove (glue will be melted). (Fig. S-1-6)
4. Release the flat pack-IC from the CBA using tweezers. (Fig. S-1-6)

### With Iron Wire:

1. Using desoldering braid, remove the solder from all pins of the flat pack-IC. When you use solder flux which is applied to all pins of the flat pack-IC, you can remove it easily. (Fig. S-1-3)
2. Affix the wire to a workbench or solid mounting point, as shown in Fig. S-1-5.
3. While heating the pins using a fine tip soldering iron or hot air blower, pull up the wire as the solder melts so as to lift the IC leads from the CBA contact pads as shown in Fig. S-1-5.
4. Bottom of the flat pack-IC is fixed with glue to the CBA; when removing entire flat pack-IC, first apply soldering iron to center of the flat pack-IC and heat up. Then remove (glue will be melted). (Fig. S-1-6)
5. Release the flat pack-IC from the CBA using tweezers. (Fig. S-1-6)

**Note:** When using a soldering iron, care must be taken to ensure that the flat pack-IC is not being held by glue. When the flat pack-IC is removed from the CBA, handle it gently because it may be damaged if force is applied.

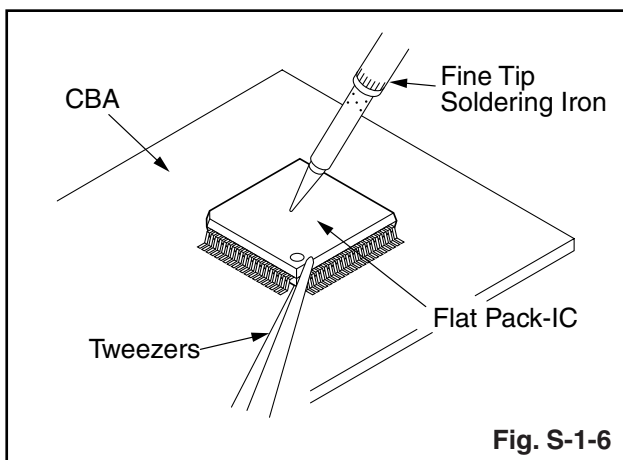
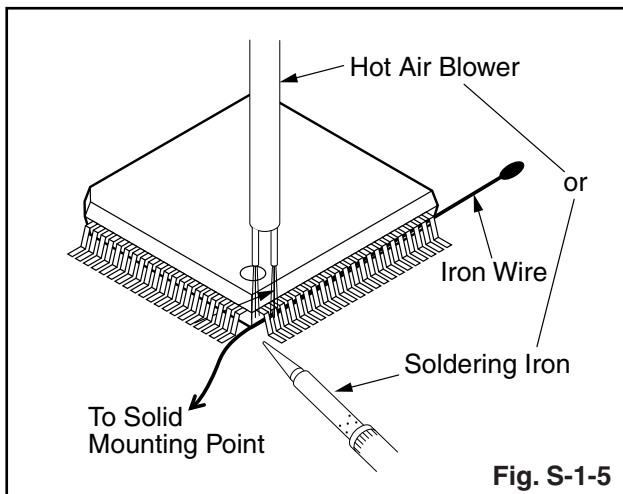

## 2. Installation

1. Using desoldering braid, remove the solder from the foil of each pin of the flat pack-IC on the CBA so you can install a replacement flat pack-IC more easily.
2. The "●" mark on the flat pack-IC indicates pin 1. (See Fig. S-1-7.) Be sure this mark matches the 1 on the PCB when positioning for installation. Then presolder the four corners of the flat pack-IC. (See Fig. S-1-8.)
3. Solder all pins of the flat pack-IC. Be sure that none of the pins have solder bridges.

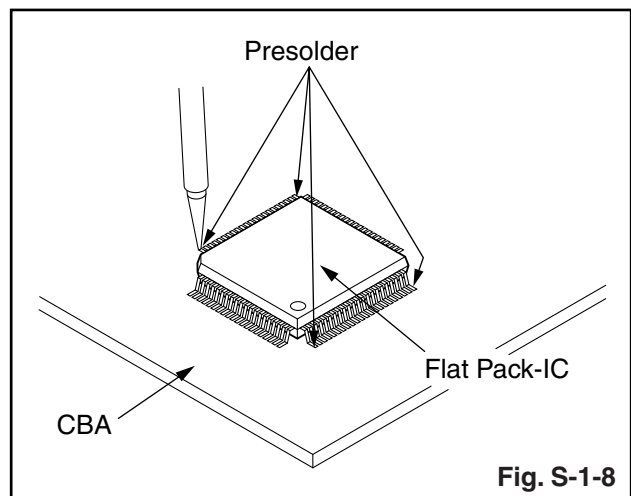
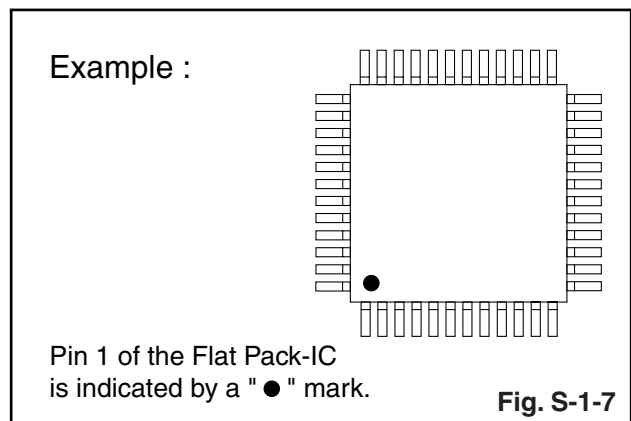

# Instructions for Handling Semi-conductors

Electrostatic breakdown of the semi-conductors may occur due to a potential difference caused by electrostatic charge during unpacking or repair work.

## 1. Ground for Human Body

Be sure to wear a grounding band (1 MΩ) that is properly grounded to remove any static electricity that may be charged on the body.

## 2. Ground for Workbench

Be sure to place a conductive sheet or copper plate with proper grounding (1 MΩ) on the workbench or other surface, where the semi-conductors are to be placed. Because the static electricity charge on clothing will not escape through the body grounding band, be careful to avoid contacting semi-conductors with your clothing.

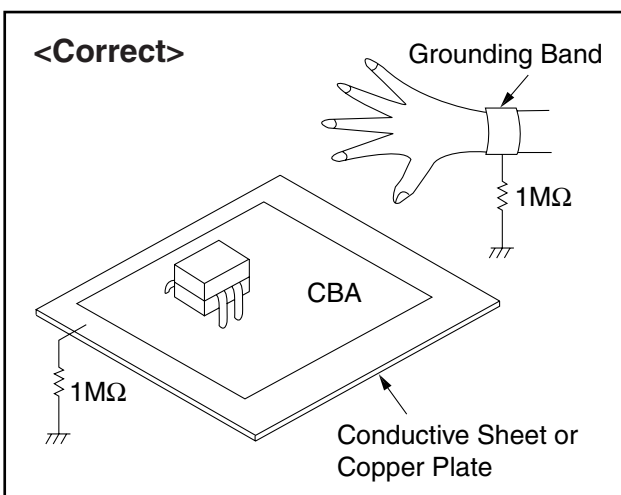
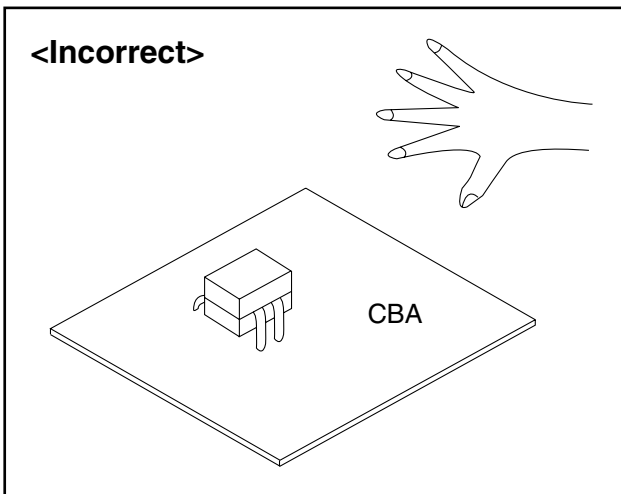

# CABINET DISASSEMBLY INSTRUCTIONS

## 1. Disassembly Flowchart

This flowchart indicates the disassembly steps to gain access to item(s) to be serviced. When reassembling, follow the steps in reverse order. Bend, route, and dress the cables as they were originally.

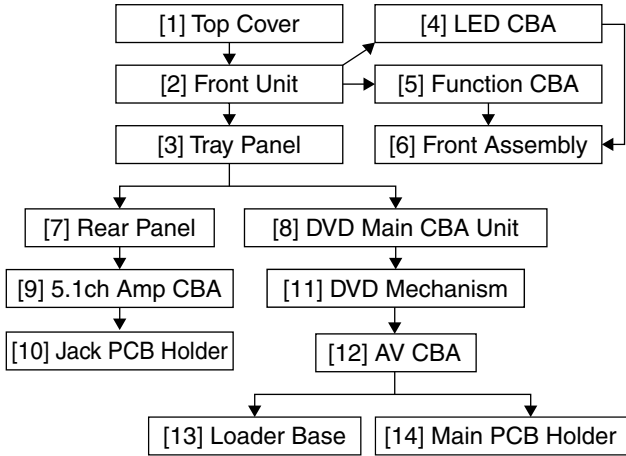

## 2. Disassembly Method

| ID/<br>Loc.<br>No. | Part                 | Removal     |  |        |
|--------------------|----------------------|-------------|--|--------|
|                    |                      | Fig.<br>No. | Remove/*Unhook/<br>Unlock/Release/<br>Unplug/Desolder            | Note   |
| [1]                | Top Cover            | D1          | 5(S-1)   | ---    |
| [2]                | Front Unit           | D2          | *2(L-1), *2(L-2),<br>*3(L-3), *CN2001,<br>*CN2002                | 1      |
| [3]                | Tray Panel           | D2          | *2(L-4)  | 1      |
| [4]                | LED CBA              | D3          | 2(S-2)   | ---    |
| [5]                | Function<br>CBA      | D3          | 3(S-3)   | ---    |
| [6]                | Front<br>Assembly    | D3          | -----  | ---    |
| [7]                | Rear Panel           | D4          | 10(S-4), (S-5), (S-6)  | ---    |
| [8]                | DVD Main<br>CBA Unit | D5          | 2(S-7A), (S-7B),<br>*CN201, *CN301,<br>*CN401, *CN601,<br>*CNS01 | 2      |
| [9]                | 5.1ch Amp<br>CBA     | D5          | (S-8), 2(L-5), *CN7101   | ---    |
| [10]               | Jack PCB<br>Holder   | D5          | 2(S-9)   | ---    |
| [11]               | DVD<br>Mechanism     | D5<br>D6    | 4(S-10)  | 2<br>3 |
| [12]               | AV CBA               | D7          | 4(S-11), (S-12)  | ---    |
| [13]               | Loader<br>Base       | D8          | 4(S-13)  | ---    |
| [14]               | Main PCB<br>Holder   | D8          | (S-14)   | ---    |

(1) (2) (3) (4) (5)

### Note:

- (1) Identification (location) No. of parts in the figures
- (2) Name of the part
- (3) Figure Number for reference

- (4) Identification of parts to be removed, unhooked, unlocked, released, unplugged, unclamped, or desoldered.

P = Spring, L = Locking Tab, S = Screw,  
CN = Connector

\* = Unhook, Unlock, Release, Unplug, or Desolder  
e.g. 2(S-2) = two Screws (S-2),  
2(L-2) = two Locking Tabs (L-2)

- (5) Refer to "Reference Notes."

### About tightening screws

When tightening screws, tighten them with the following torque.

| Screws   | Torque          |
|--|-----------------|
| (S-1), (S-2), (S-3), (S-4), (S-5),<br>(S-6), (S-7A), (S-8), (S-9), (S-10),<br>(S-11), (S-12), (S-13), (S-14) | 0.45 ± 0.05 N·m |
| (S-7B)   | 0.38 ± 0.04 N·m |

### Reference Notes

- CAUTION 1:** Locking Tabs (L-1), (L-2), (L-3) and (L-4) are fragile. Be careful not to break them.
  - 1) Release two Locking Tabs (L-1), then release two Locking Tabs (L-2).
  - 2) Release three Locking Tabs (L-3).
  - 3) Disconnect connectors CN2001 and CN2002, and remove the Front Unit.
- CAUTION 2:** Electrostatic breakdown of the laser diode in the optical system block may occur as a potential difference caused by electrostatic charge accumulated on cloth, human body etc., during unpacking or repair work.  
To avoid damage of pickup follow next procedures.
  - 1) Short the three short lands of FPC cable with solder before removing the FFC cable (CN201) from it. If you disconnect the FFC cable (CN201), the laser diode of pickup will be destroyed. (Fig. D5)
  - 2) Disconnect Connectors (CN301), (CN401), (CN601) and (CNS01). Remove two Screws (S-7A) and (S-7B) and lift the DVD Main CBA Unit. (Fig. D5)
- CAUTION 3:** When reassembling, confirm the FFC cable (CN201) is connected completely. Then remove the solder from the three short lands of FPC cable. (Fig. D5)

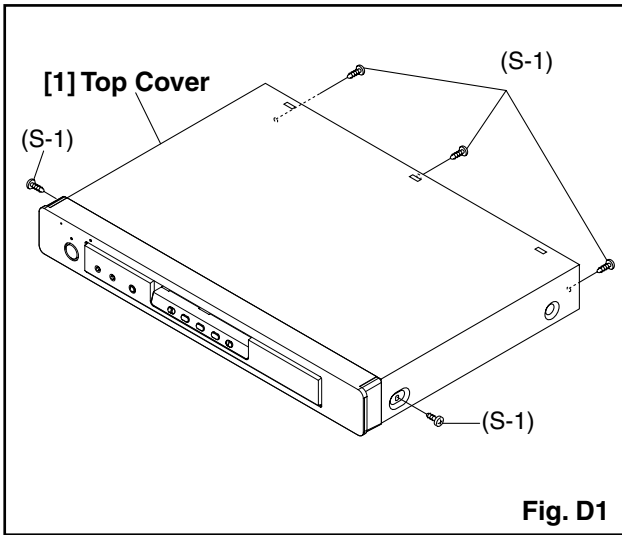

**Fig. D1**

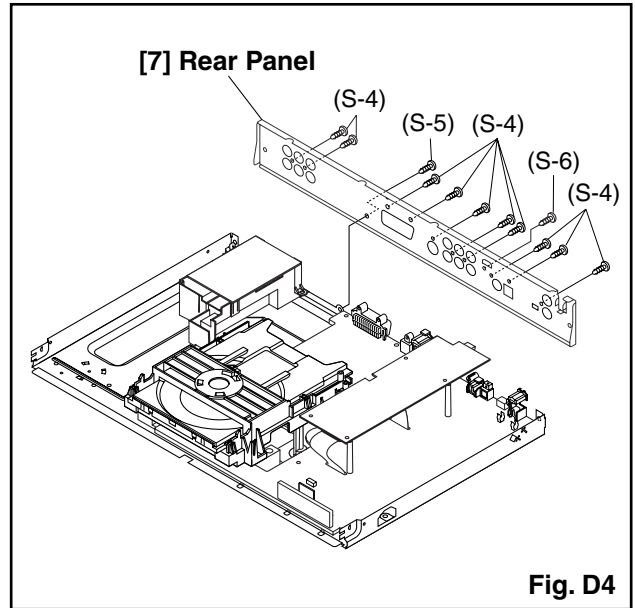

**Fig. D4**

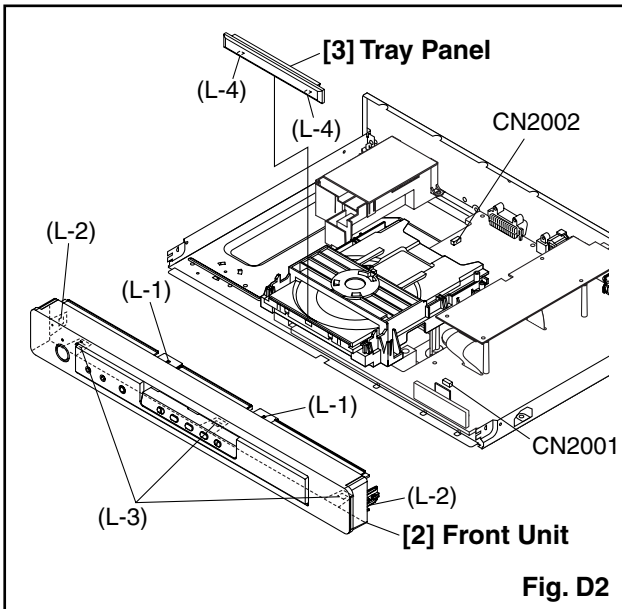

**Fig. D2**

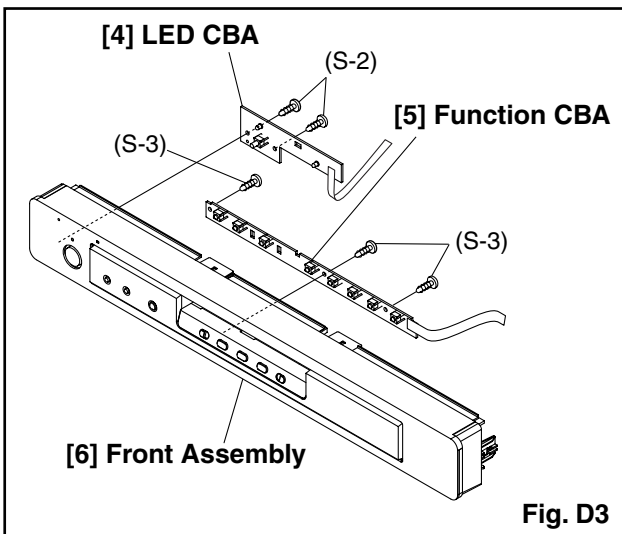
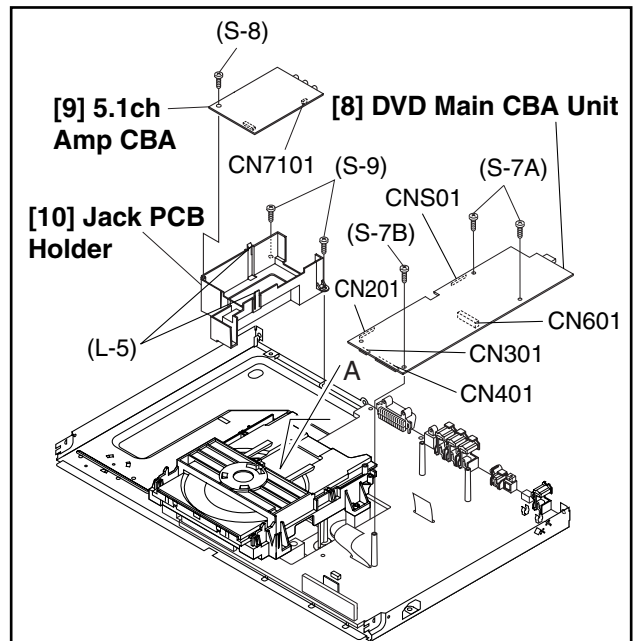

**Fig. D3**

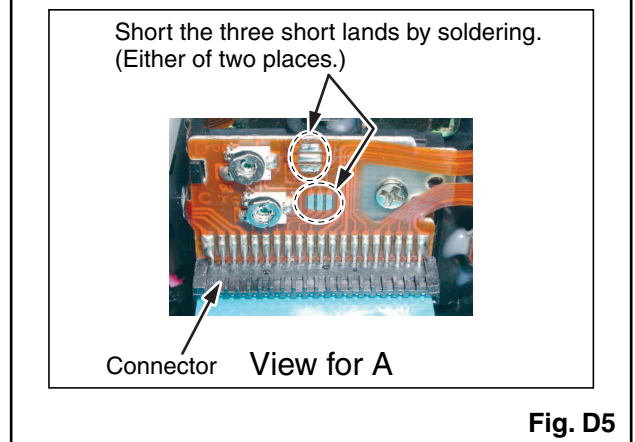

**Fig. D5**

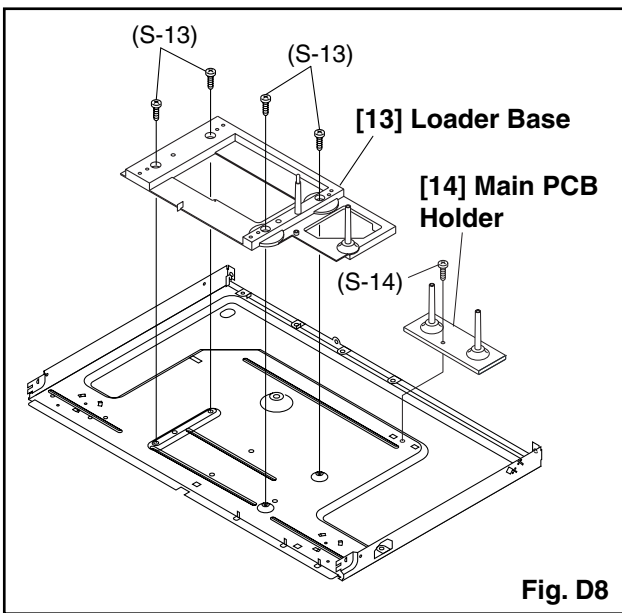
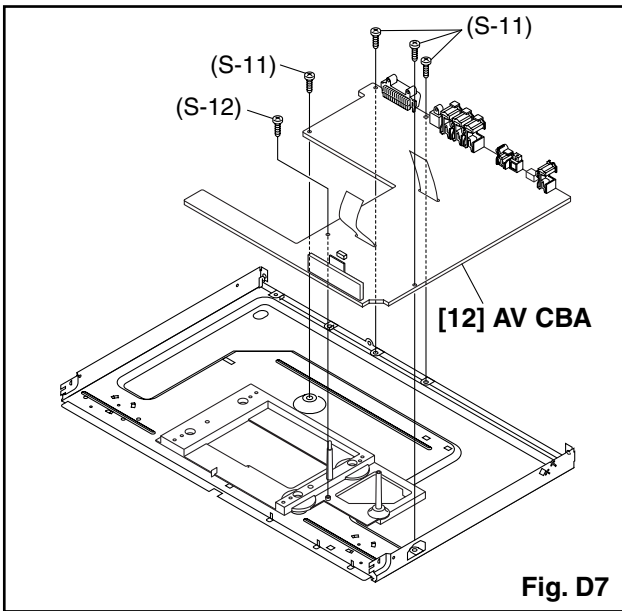
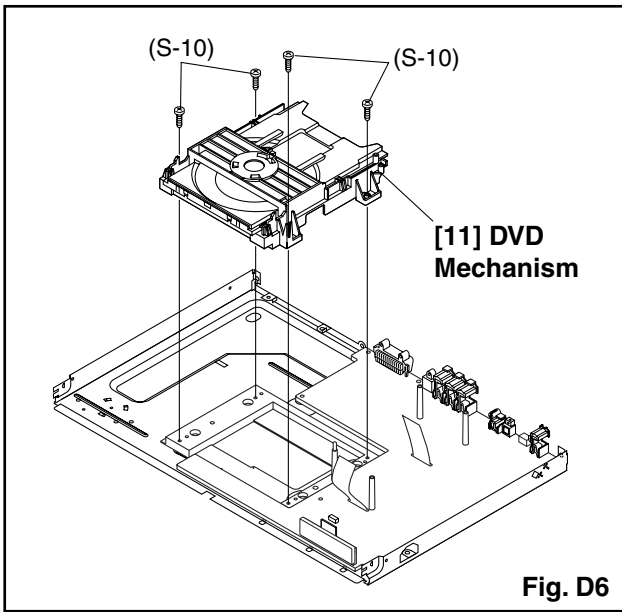



### 3. How to Eject Manually

1. Remove the Top Cover.
2. Rotate the roulette in the direction of the arrow as shown below.

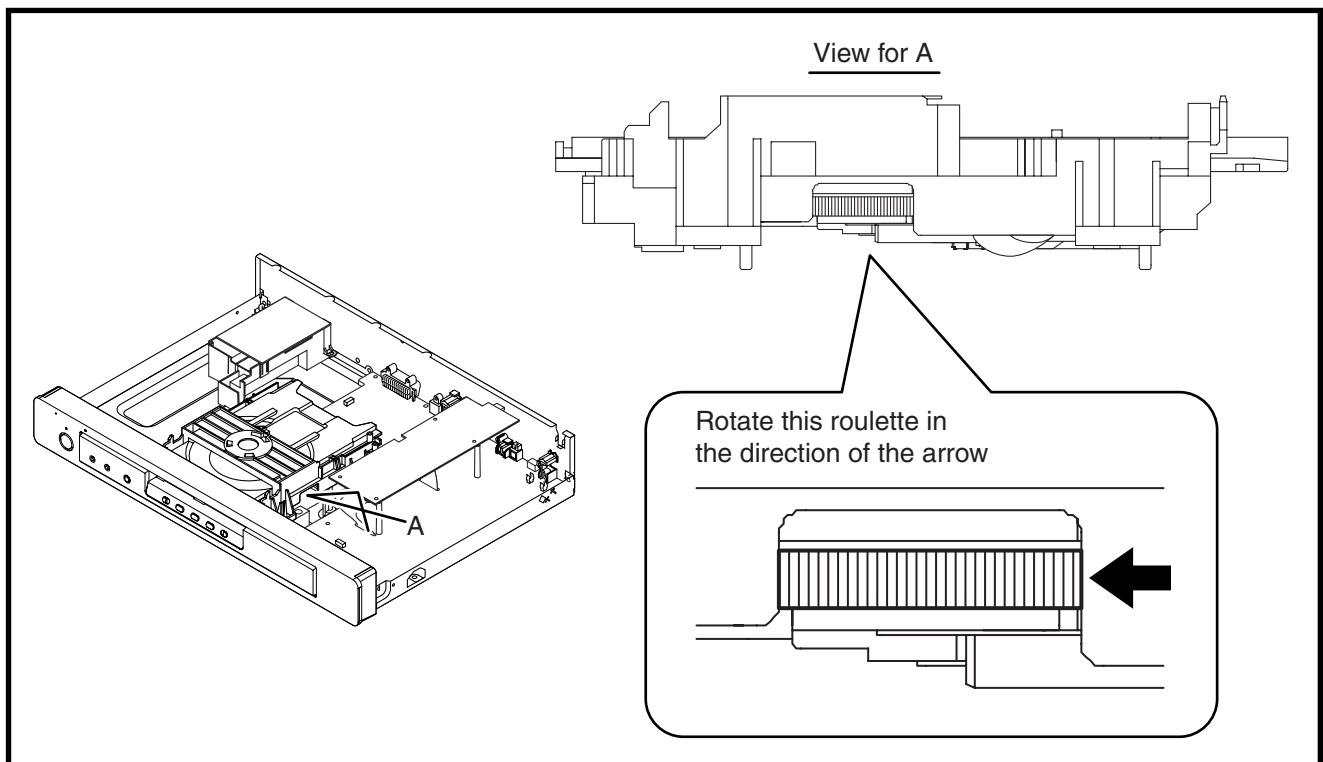

# HOW TO INITIALIZE THE DVD PLAYER

To put the program back at the factory-default, initialize the DVD player as the following procedure.

1. Press [1], [2], [3], [4], and [DISPLAY] buttons on the remote control unit in that order.

Fig. a appears on the screen.

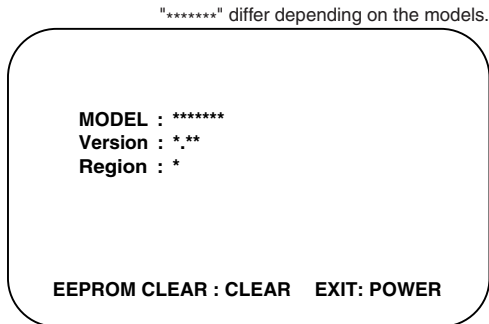

Fig. a

2. Press [CLEAR] button on the remote control unit.

Fig. b appears on the screen.

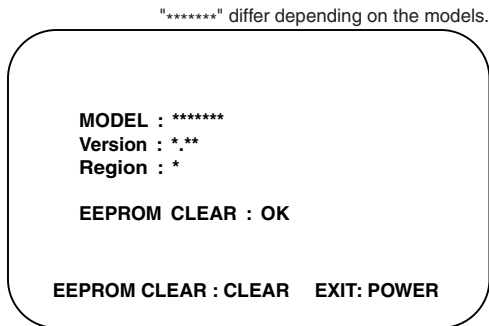

Fig. b

When "OK" appears on the screen, the factory default will be set.

3. To exit this mode, press [POWER] button.

# FIRMWARE RENEWAL MODE

1. Turn the power on and remove the disc on the tray.
2. To put the DVD player into version up mode, press [9], [8], [7], [6], and [SEARCH MODE] buttons on the remote control unit in that order. The tray will open automatically.

Fig. a appears on the screen and Fig. b appears on the VFD.

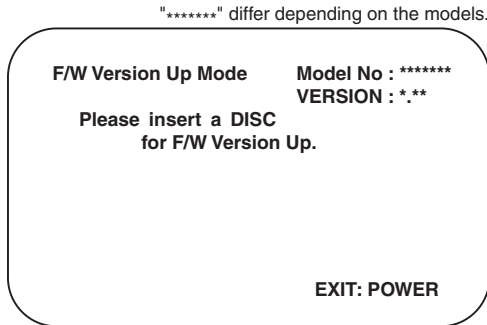

Fig. a Version Up Mode Screen

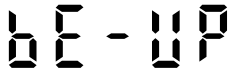

Fig. b VFD in Version Up Mode

The DVD player can also enter the version up mode with the tray open. In this case, Fig. a will be shown on the screen while the tray is open.

3. Load the disc for version up.
4. The DVD player enters the F/W version up mode automatically. Fig. c appears on the screen and Fig. d appears on the VFD. If you enter the F/W for different models, "Disc Error" will appear on the screen, then the tray will open automatically.

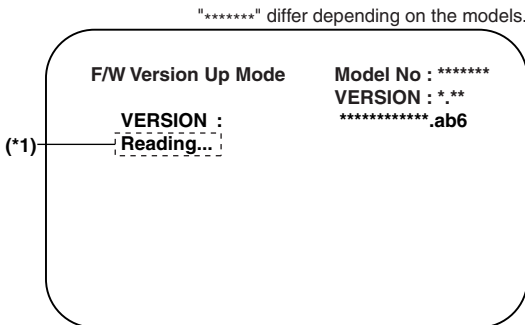

Fig. c Programming Mode Screen



Fig. d VFD in Programming Mode (Example)

The appearance shown in (\*1) of Fig. c is described as follows:

| No. | Appearance     | State                         |
|-----|----------------|-------------------------------|
| 1   | Reading...     | Sending files into the memory |
| 2   | Erasing...     | Erasing previous version data |
| 3   | Programming... | Writing new version data      |

5. After programming is finished, the tray opens automatically. Fig. e appears on the screen and the checksum in (\*2) of Fig. e appears on the VFD (Fig. f).

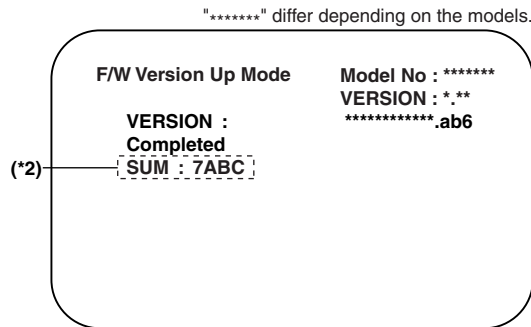

Fig. e Completed Program Mode Screen



Fig. f VFD upon Finishing the Programming Mode (Example)

At this time, no button is available.

6. Remove the disc on the tray.
7. Unplug the AC cord from the AC outlet. Then plug it again.
8. Turn the power on by pressing the [POWER] button and the tray will close.
9. Press [1], [2], [3], [4], and [DISPLAY] buttons on the remote control unit in that order. Fig. g appears on the screen.

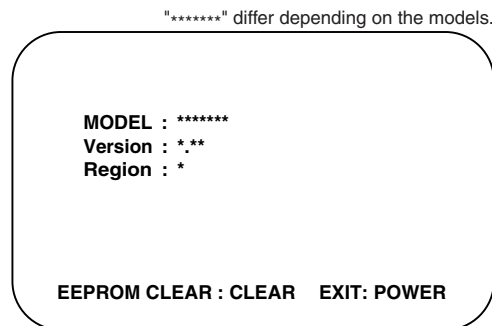

Fig. g

10. Press [CLEAR] button on the remote control unit. Fig. h appears on the screen.

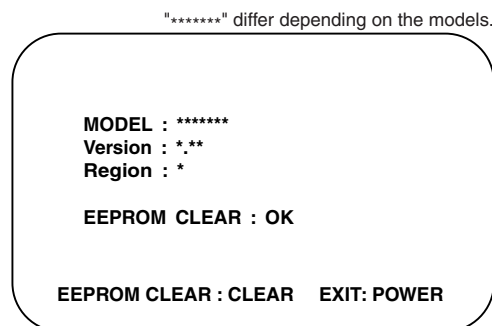

Fig. h

When "OK" appears on the screen, the factory default will be set. Then the firmware renewal mode is complete.

11. To exit this mode, press [POWER] button.

# TROUBLESHOOTING

## FLOW CHART NO.1

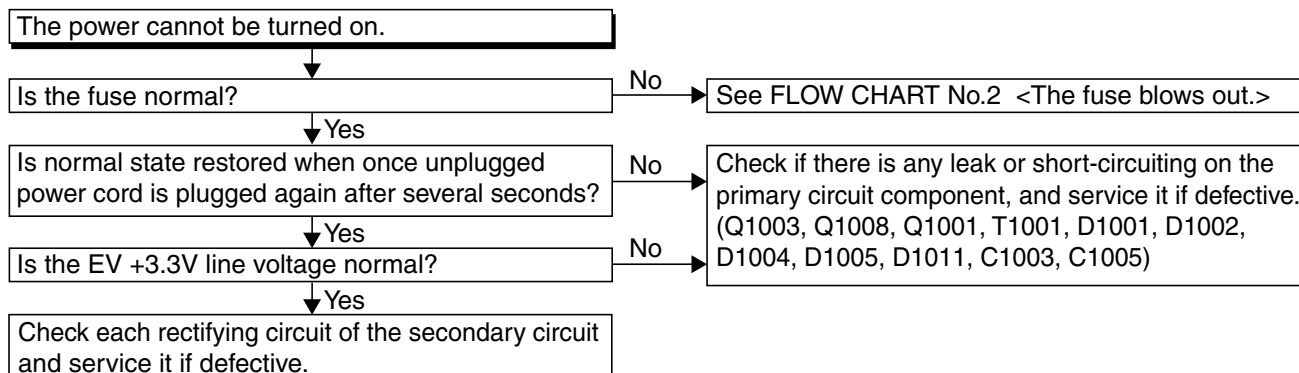

## FLOW CHART NO.2

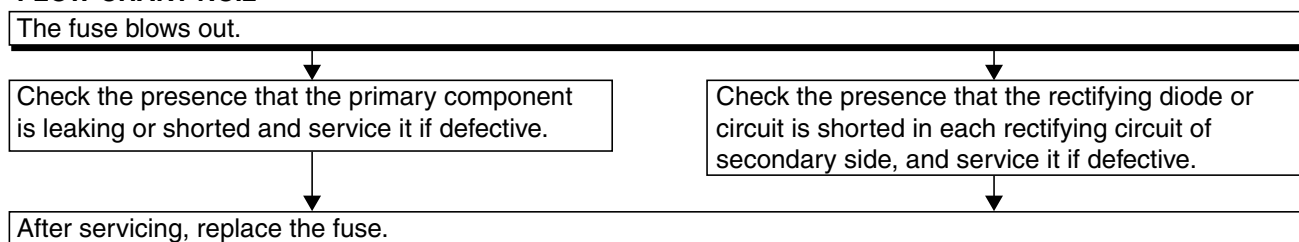

## FLOW CHART NO.3

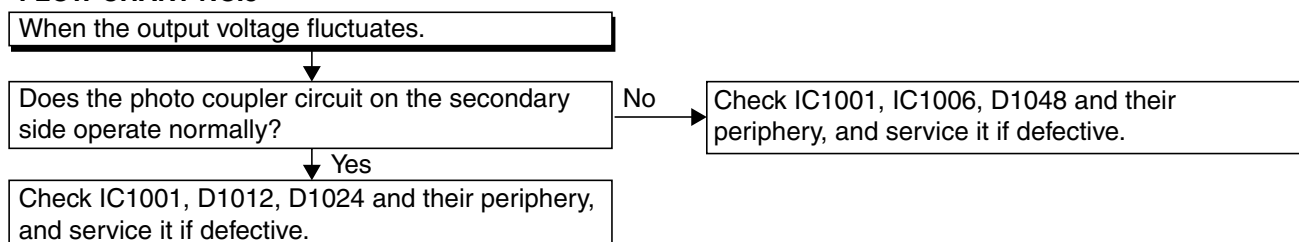

## FLOW CHART NO.4

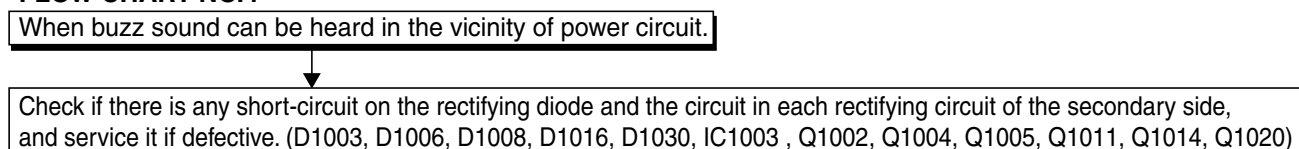

## FLOW CHART NO.5

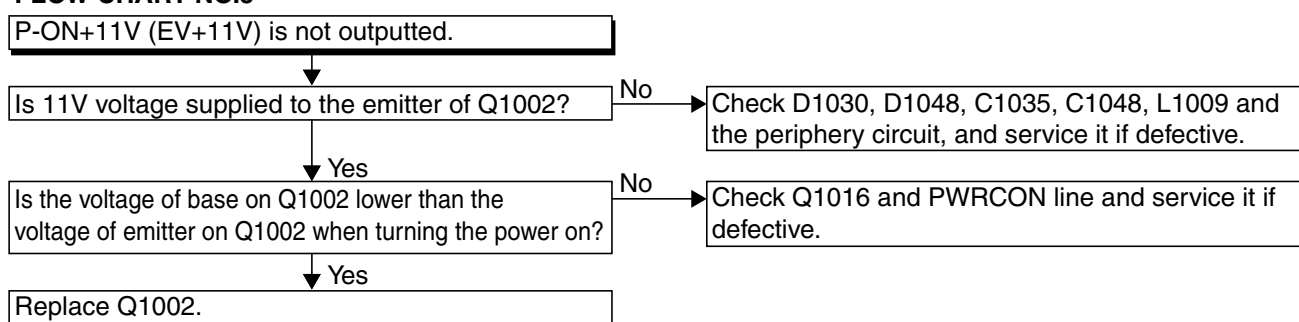

## FLOW CHART NO.6

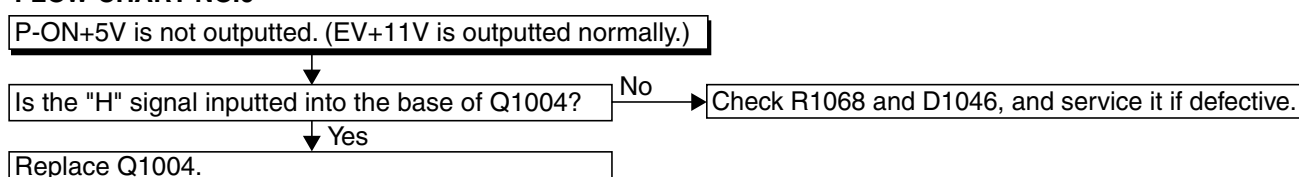

### FLOW CHART NO.7

P-ON+3.3V is not outputted. (P-ON+11V is outputted normally.)

Is 3.3V voltage supplied to the collector of Q1011?

No

Check D1008, C1007, C1038, L1007 and the periphery circuit, and service it if defective.

Yes

Replace Q1011 or R1067.

### FLOW CHART NO.8

EV+5V is not outputted.

Is EV+11V outputted normally?

No

Refer to "FLOW CHART NO.5"  
<P-ON+11V (EV+11V) is not outputted.>

Yes

Is the "H" signal inputted into the base of Q1014?

No

Check D1047, R1069, R1098 and the periphery circuit, and service it if defective.

Yes

Replace Q1014.

### FLOW CHART NO.9

EV+1.2V is not outputted.

Is 2.5V voltage supplied to Pin(3) of IC1003?

No

Check D1006, L1008, C1014 and the periphery circuit, and service it if defective.

Yes

Replace IC1003.

### FLOW CHART NO.10

EV+3.3V is not outputted.

Is 3.3V voltage supplied to the collector of Q1020?

No

Check D1008, C1007, C1038, L1007 and the periphery circuit, and service it if defective.

Yes

Is EV+11V outputted normally?

No

Refer to "FLOW CHART NO.5"  
<P-ON+11V (EV+11V) is not outputted.>

Yes

Is the "H" signal inputted into the base of Q1020?

No

Check R1050 and the periphery circuit, and service it if defective.

Yes

Replace Q1020.

### FLOW CHART NO.11

The fluorescent display tube does not light up.

Is 3.3V voltage supplied to Pins(6,24) of IC2001?

No

Check the EV+3.3V line and service it if defective.

Yes

Is the voltage of approximately -20V supplied to Pin(15) of IC2001?

No

Refer to "FLOW CHART NO.12"  
<-FL is not outputted.>

Yes

Is there 500kHz oscillation at Pin(26) of IC2001?

No

Check R2002, IC2001 and their periphery, and service it if defective.

Yes

Are the filament voltage supplied between Pins(1, 2) and Pins(29, 30) of the fluorescent display tube? And the negative voltage applied between these pins and GND?

No

Is -15V voltage supplied to collector of Q1005?

Yes

Replace the fluorescent display tube.

Is the "H" signal inputted to base of Q1016?

No

Check PWRCON line, and service it if defective.

Yes

Check Q1015, Q1016, D1055, and their periphery, and service it if defective.

### FLOW CHART NO.12

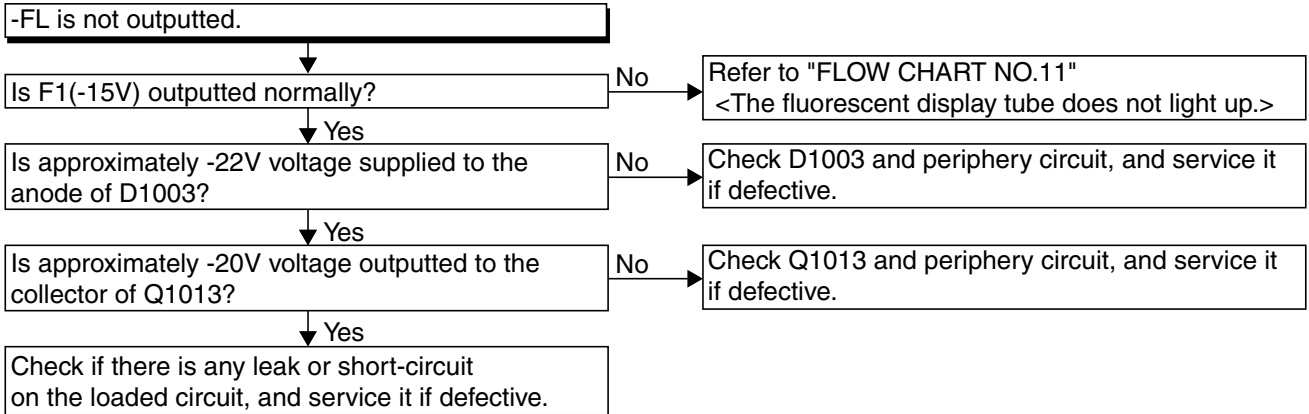

### FLOW CHART NO.13

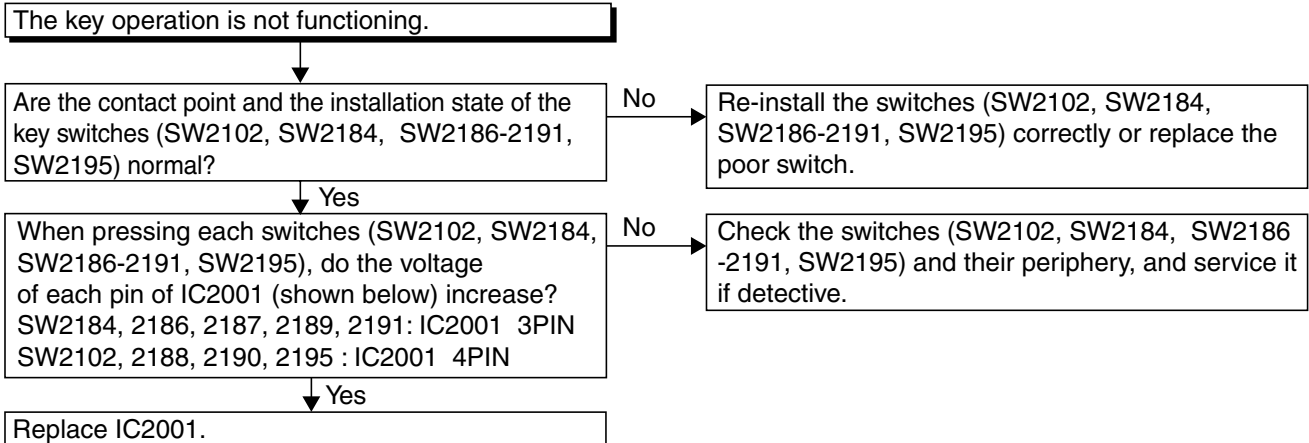

### FLOW CHART NO.14

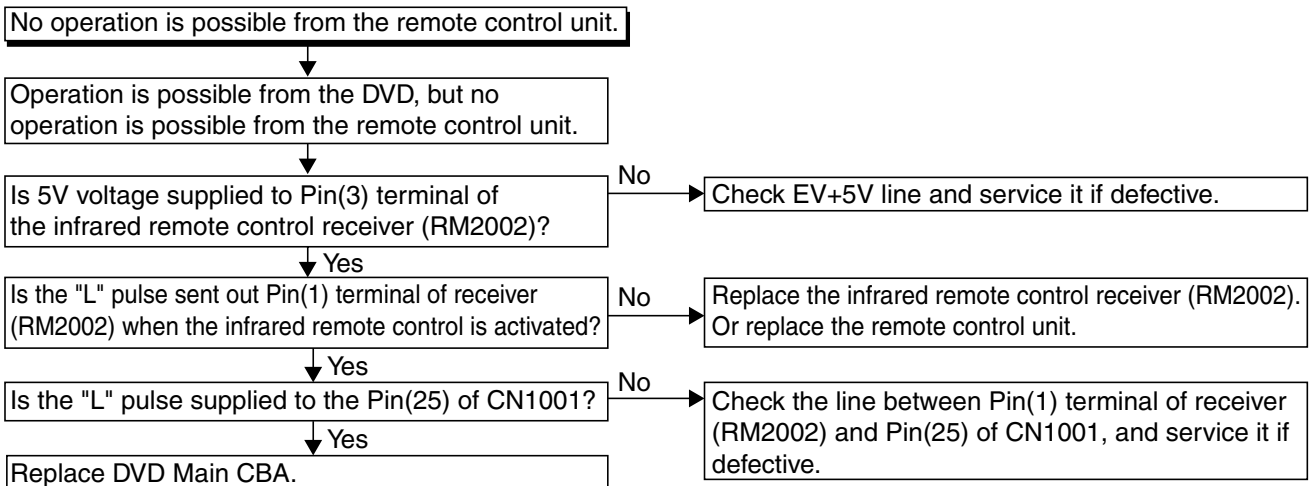

### FLOW CHART NO.15

The disc tray cannot be opened and closed. (It can be done using the remote control unit.)

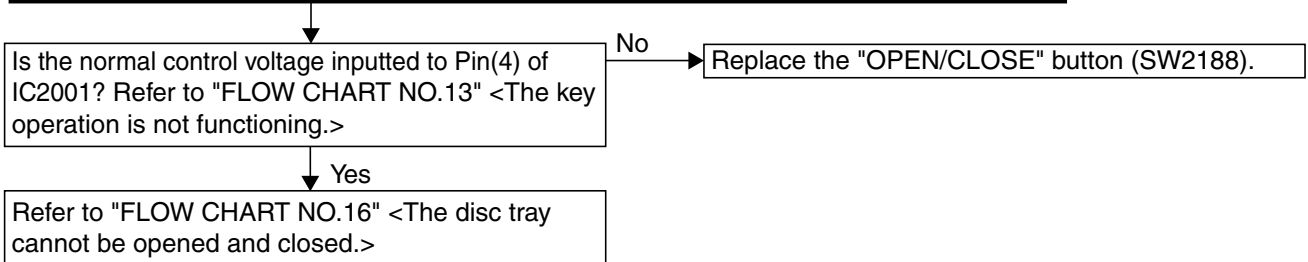

### FLOW CHART NO.16

The disc tray cannot be opened and closed.

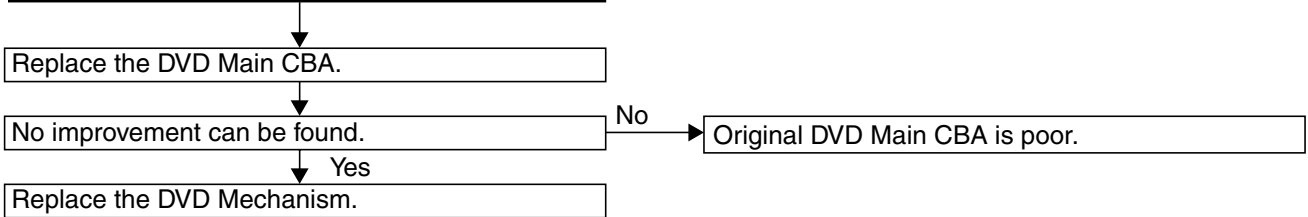

### FLOW CHART NO.17

[No Disc] indicated. (When the focus error occurs.)

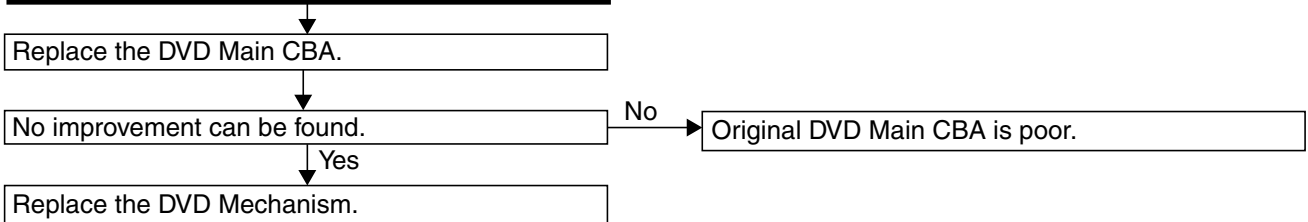

### FLOW CHART NO.18

[No Disc] indicated. (When the focus servo is not functioning.)

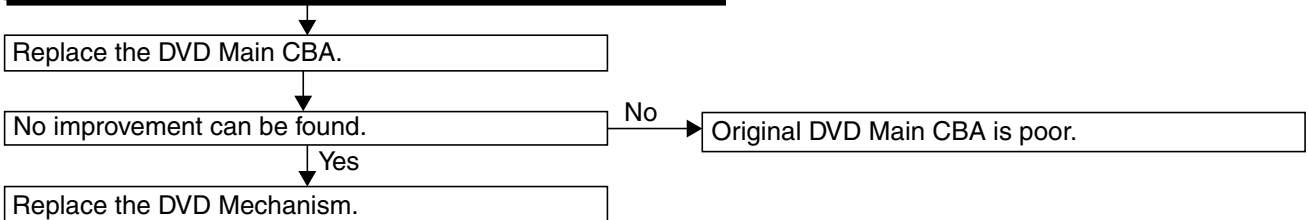

### FLOW CHART NO.19

[No Disc] indicated. (When the laser beam does not light up.)

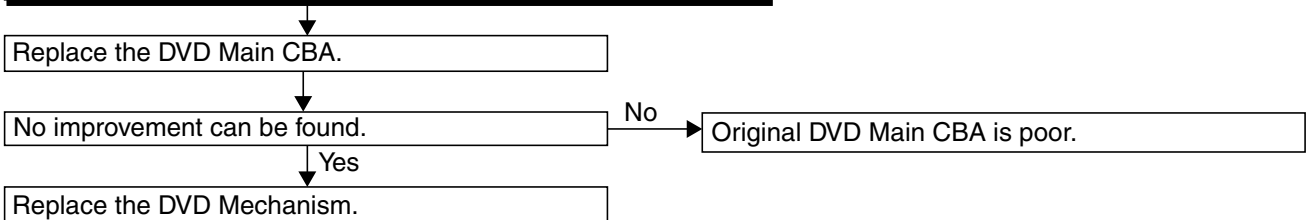

### FLOW CHART NO.20

Both functions of picture and sound do not operate normally.

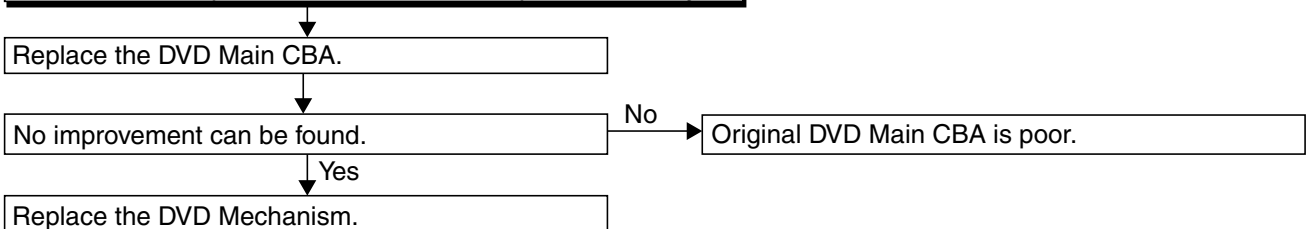

**FLOW CHART NO.21**

Picture does not appear normally.

Set the disc on the disc tray, and playback.

Are the video signals outputted to each pin of CN1601 on the AV CBA?

|        |       |          |
|--------|-------|----------|
| CN1601 | 1PIN  | S-Y(I)   |
| CN1601 | 4PIN  | Cr/Pr, R |
| CN1601 | 6PIN  | Cb/Pb, B |
| CN1601 | 8PIN  | Y, G     |
| CN1601 | 10PIN | S-C      |

No → Replace the DVD Main CBA or DVD Mechanism.

Yes

Are the video signals shown above inputted into each pin of IC1401, IC1402, IC1405?

|                               |        |       |        |
|-------------------------------|--------|-------|--------|
| S-VIDEO OUT, VIDEO OUT is NG. | IC1401 | 3PIN  | S-Y(I) |
|                               | IC1401 | 1PIN  | S-C    |
| RGB OUT is NG.                | IC1402 | 11PIN | R      |
|                               | IC1402 | 6PIN  | G      |
|                               | IC1402 | 9PIN  | B      |
| Y, Cb/Pb, Cr/Pr is NG.        | IC1405 | 6PIN  | Y      |
|                               | IC1405 | 9PIN  | Cb/Pb  |
|                               | IC1405 | 11PIN | Cr/Pr  |

No → Check the line between each pin of CN1601 and each pin of IC1401, IC1402, IC1405 on the AV CBA, and service it if defective.

|        |       |   |        |      |        |
|--------|-------|---|--------|------|--------|
| CN1601 | 1PIN  | → | IC1401 | 3PIN | S-Y(I) |
| CN1601 | 10PIN | → | IC1401 | 1PIN | S-C    |
| CN1601 | 6PIN  | → | IC1402 | 9PIN | B      |
|        |       | → | IC1405 | 9PIN | Cb/Pb  |
| CN1601 | 8PIN  | → | IC1402 | 6PIN | G      |
|        |       | → | IC1405 | 6PIN | Y      |

Yes

Are the video signals outputted to each pin of IC1401, IC1402, IC1405?

|                               |        |       |        |
|-------------------------------|--------|-------|--------|
| S-VIDEO OUT, VIDEO OUT is NG. | IC1401 | 5PIN  | S-Y(I) |
|                               | IC1401 | 7PIN  | S-C    |
|                               | IC1401 | 6PIN  | CVBS   |
| RGB OUT is NG.                | IC1402 | 13PIN | R      |
|                               | IC1402 | 18PIN | G      |
|                               | IC1402 | 15PIN | B      |
| Y, Cb/Pb, Cr/Pr is NG.        | IC1405 | 18PIN | Y      |
|                               | IC1405 | 15PIN | Cb/Pb  |
|                               | IC1405 | 13PIN | Cr/Pr  |

No → Is 5V voltage applied to the pin(1, 24) of IC1402, IC1405 and pin (4) of IC1401?

Yes → Replace IC1401, IC1402, IC1405.

No → Check P-ON+5V line and service it if defective.

Yes

Are the video signals outputted to the specific output terminal?

Are the luminance signals outputted to the S-VIDEO OUT terminal (JK1401)?

Are the chroma signals outputted to the S-VIDEO OUT terminal (JK1401)?

Are the composite video signals outputted to the VIDEO OUT terminal (JK1404)?

Are the R, G, B signals outputted to the RGB OUT terminal (JK1405)?

Are the Y, Cb/Pb, Cr/Pr signals outputted to the COMPONENT OUT terminal (JK1404)?

No → Check the periphery of JK1401 from Pin (5) of IC1401 and service it if defective.

No → Check the periphery of JK1401 from Pin (7) of IC1401 and service it if defective.

No → Check the periphery of JK1404 from Pin (6) of IC1401 and service it if defective.

No → Check the periphery of JK1405 from Pins (13, 15, 18) of IC1402 and service it if defective.

No → Check the periphery of JK1404 from Pins (13, 15, 18) of IC1405 and service it if defective.



**FLOW CHART NO.22**

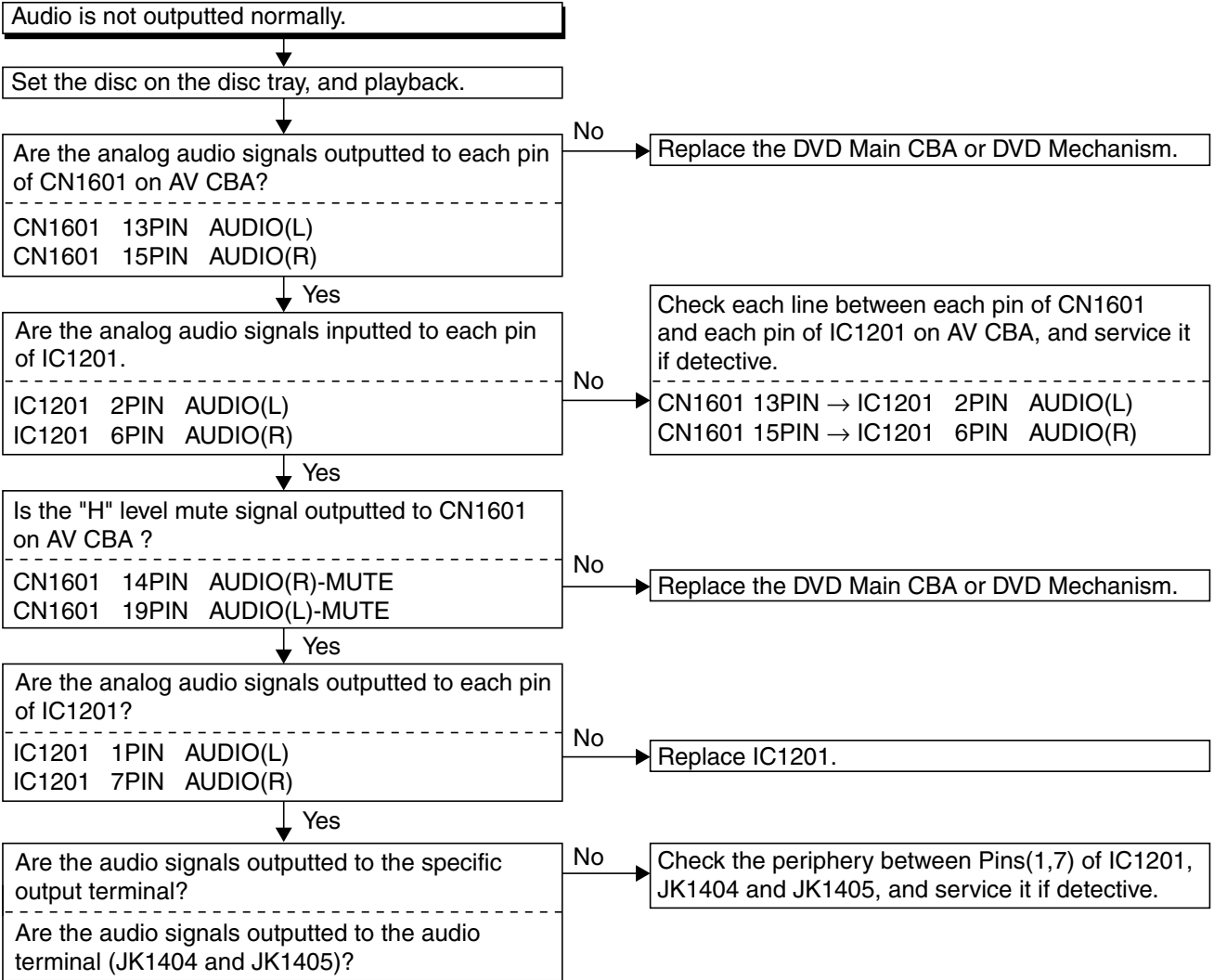

**FLOW CHART NO.23**

Audio is not outputted. (JK7101)

Set the disc (with 5.1ch Audio) on the disc tray, and playback.

Are the analog audio signals outputted to each pin of CN7102 on 5.1ch Amp CBA.

---

CN7102 15PIN FRONT(L)  
 CN7102 13PIN FRONT(R)  
 CN7102 11PIN SURROUND(L)  
 CN7102 9PIN SURROUND(R)  
 CN7102 7PIN CENTER  
 CN7102 5PIN SUBWOOFER

No → Replace the DVD Main CBA or DVD Mechanism.

Yes

Are the analog audio signals inputted to each pin of IC7301, IC7401 and IC7501.

---

IC7301 2, 6PIN FRONT(L/R)  
 IC7401 2, 6PIN SURROUND(L/R)  
 IC7501 2, 6PIN CENTER/SUBWOOFER

No → Check each line between each pin of CN7102 and each pin of IC7301, IC7401 and IC7501 and service it if defective.  
 CN7102 15,13PIN → IC7301 2,6PIN FRONT(L/R)  
 CN7102 11,9PIN → IC7401 2,6PIN SURROUND(L/R)  
 CN7102 7,5PIN → IC7501 2,6PIN CENTER/SUBWOOFER

Yes

Are the analog audio signals outputted to each pin of IC7301, IC7401 and IC7501.

---

IC7301 1,7PIN FRONT(L/R)  
 IC7401 1,7PIN SURROUND(L/R)  
 IC7501 1,7PIN CENTER/SUBWOOFER

No → Replace ICs (IC7301, IC7401 or IC7501).

Yes

Do the mute signals of CN7102 on 5.1ch Amp CBA become to "H" level?

---

FRONT(L) → CN7102 14PIN  
 FRONT(R) → CN7102 12PIN  
 SURROUND(L) → CN7102 10PIN  
 SURROUND(R) → CN7102 8PIN  
 CENTER → CN7102 6PIN  
 SUBWOOFER → CN7102 4PIN

No → Replace the DVD Main CBA Unit.

Yes

Is the analog audio signal of each line outputted to each terminal of JK7101 (as shown below) ?

---

IC7301 1PIN → JK7101 FRONT(L)  
 IC7301 7PIN → JK7101 FRONT(R)  
 IC7401 1PIN → JK7101 SURROUND(L)  
 IC7401 7PIN → JK7101 SURROUND(R)  
 IC7501 1PIN → JK7101 CENTER  
 IC7501 7PIN → JK7101 SUBWOOFER

No → Check each line and service it if defective.

# BLOCK DIAGRAMS

## System Control / Servo Block Diagram

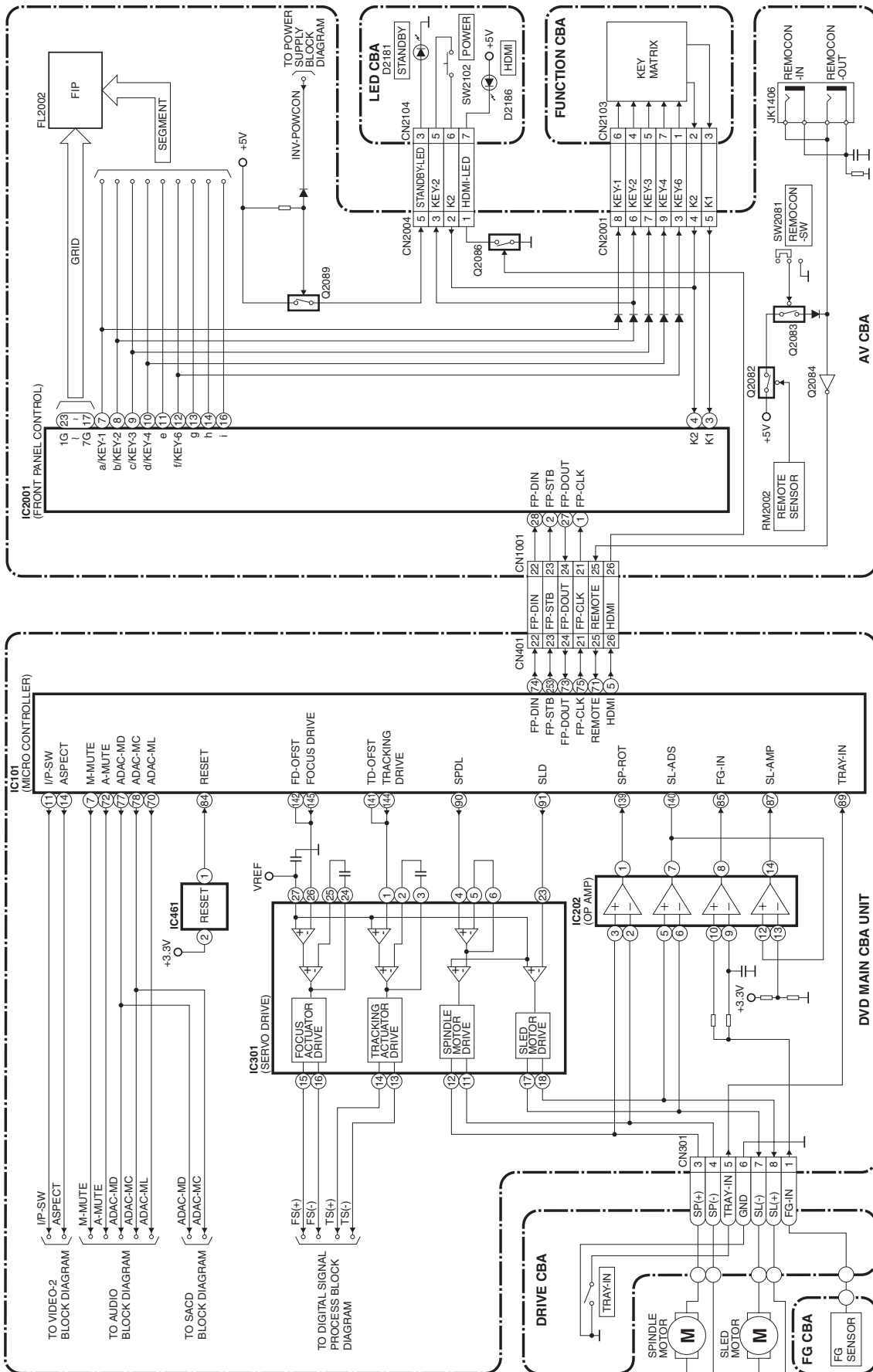

# Digital Signal Process Block Diagram

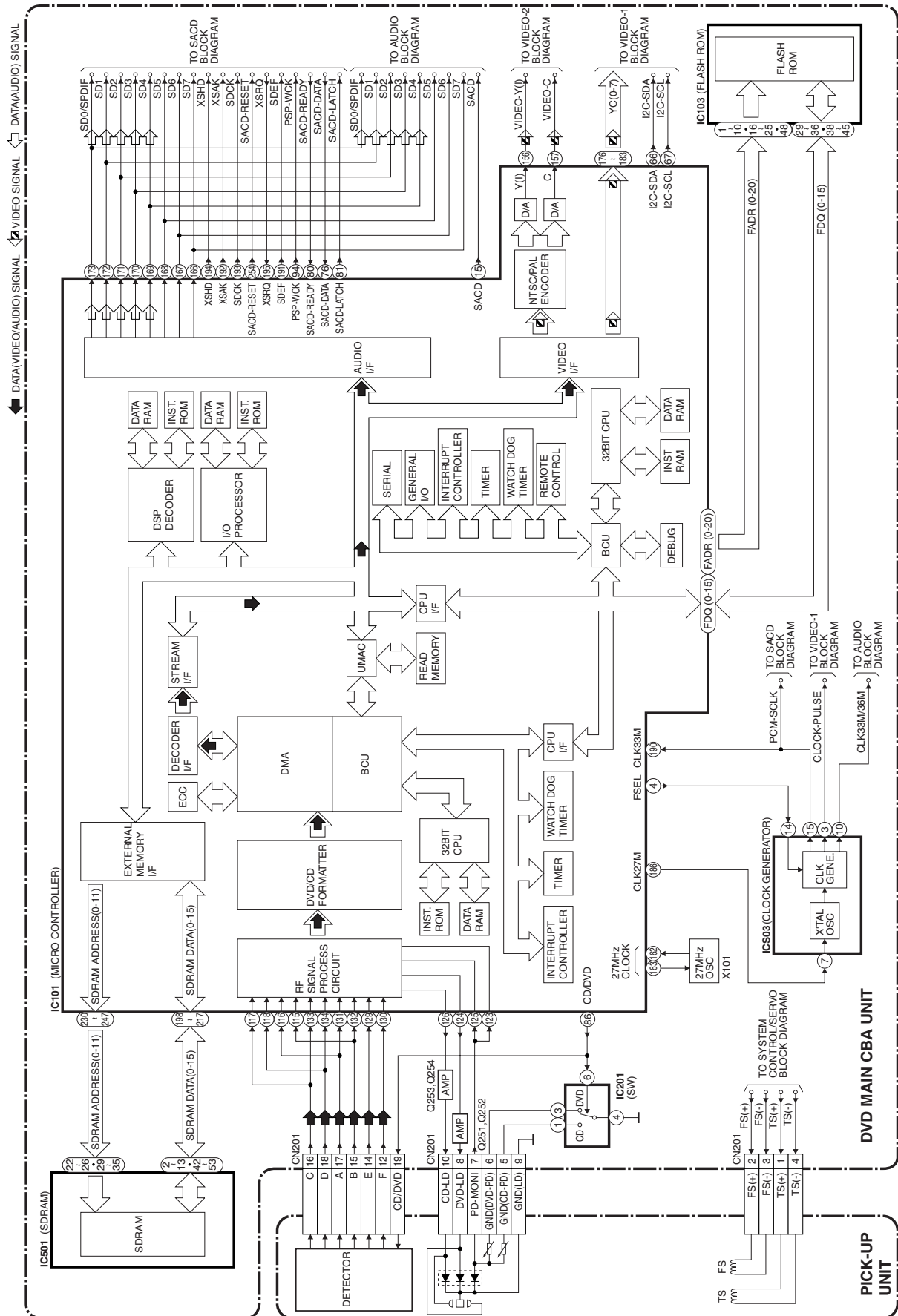

# Video-1 Block Diagram

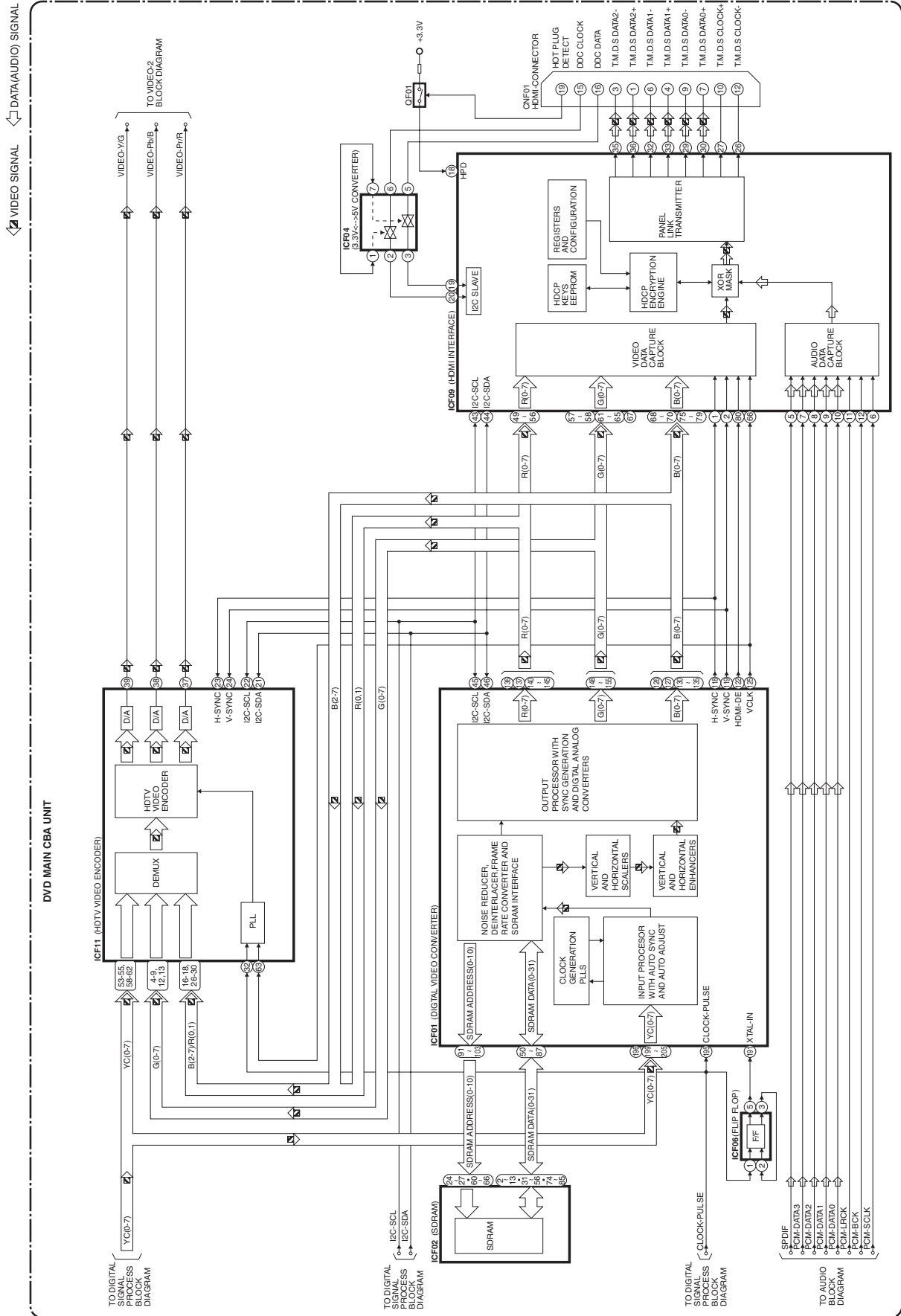

# Video-2 Block Diagram

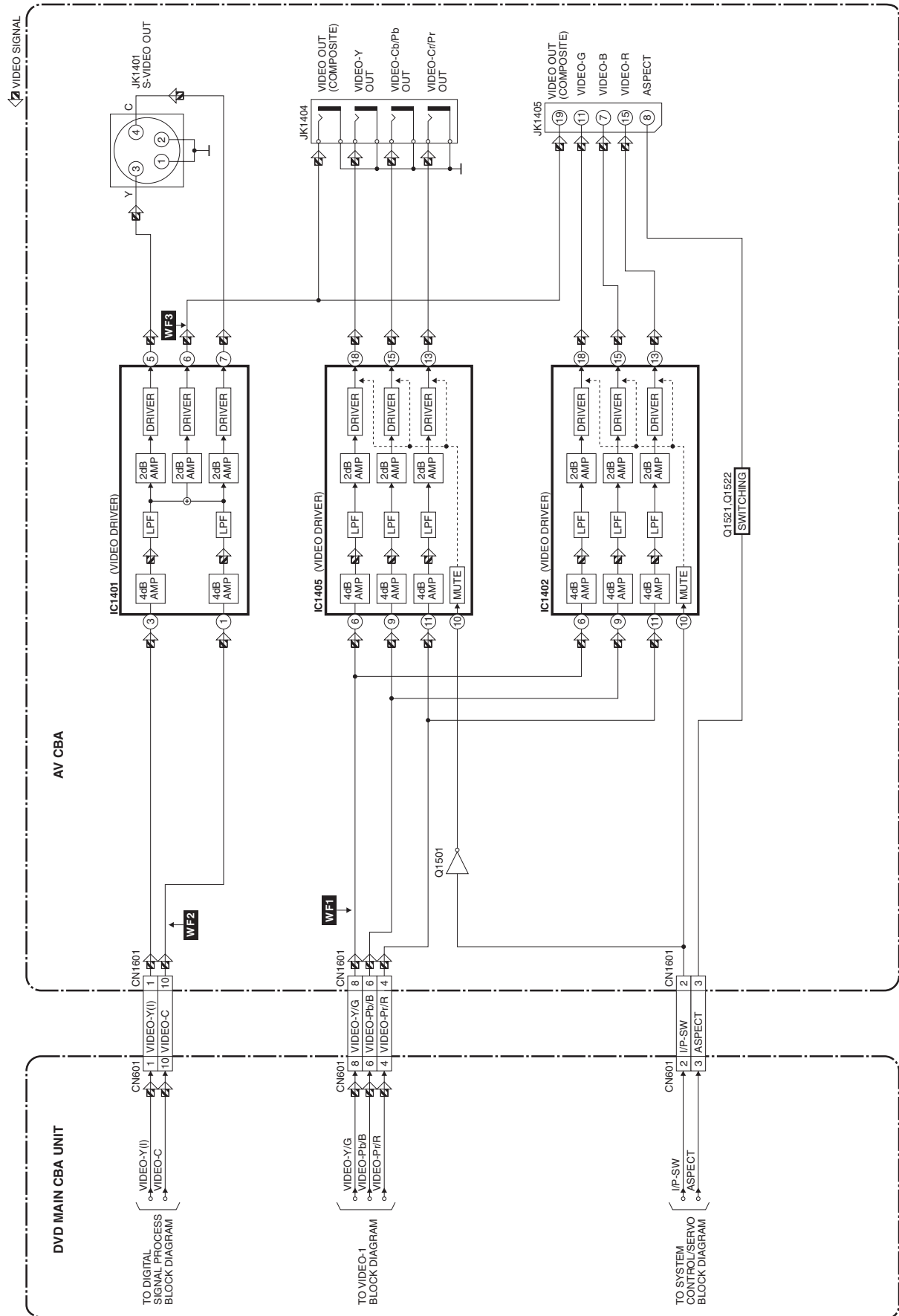

# Audio Block Diagram

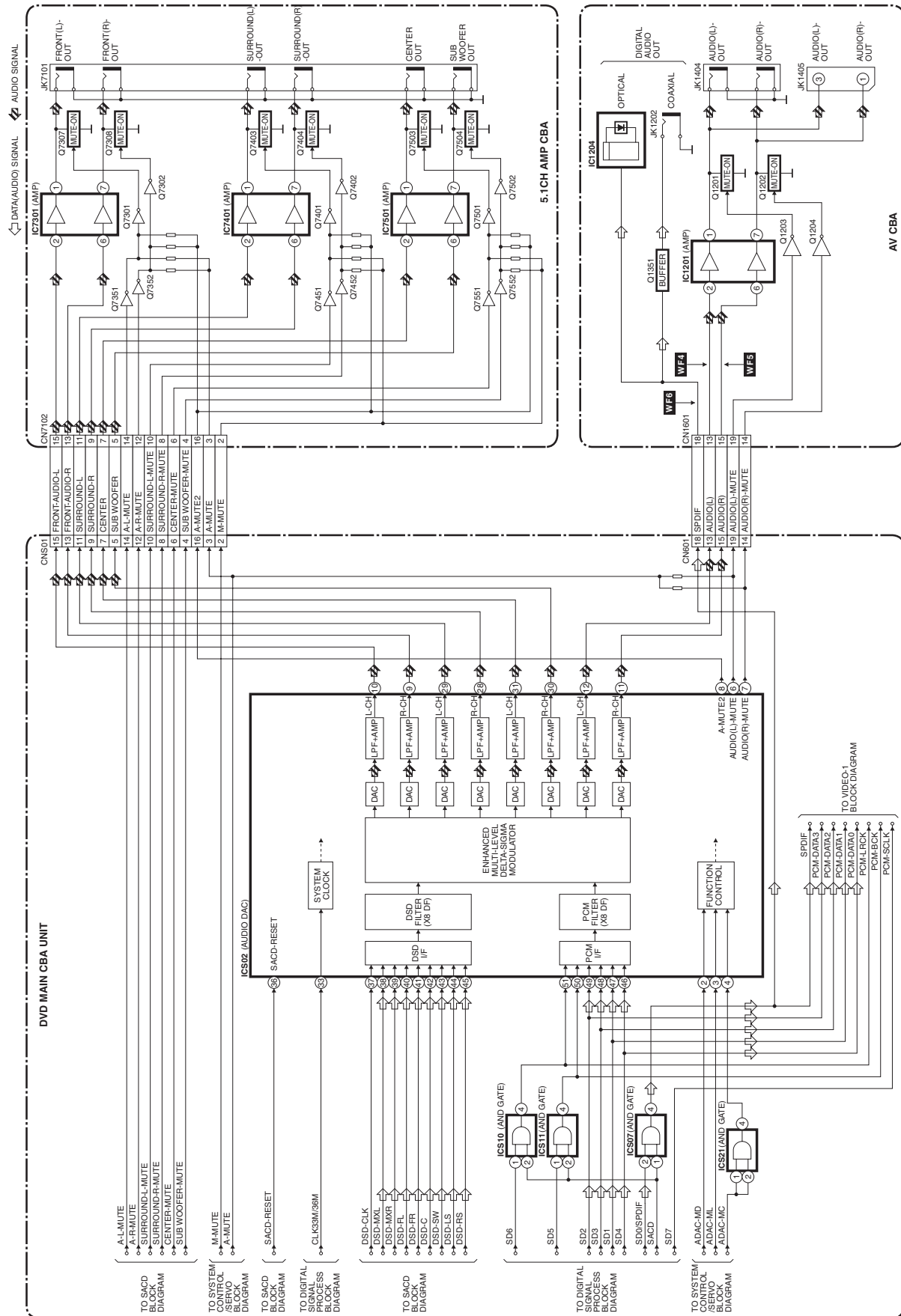

# SACD Block Diagram

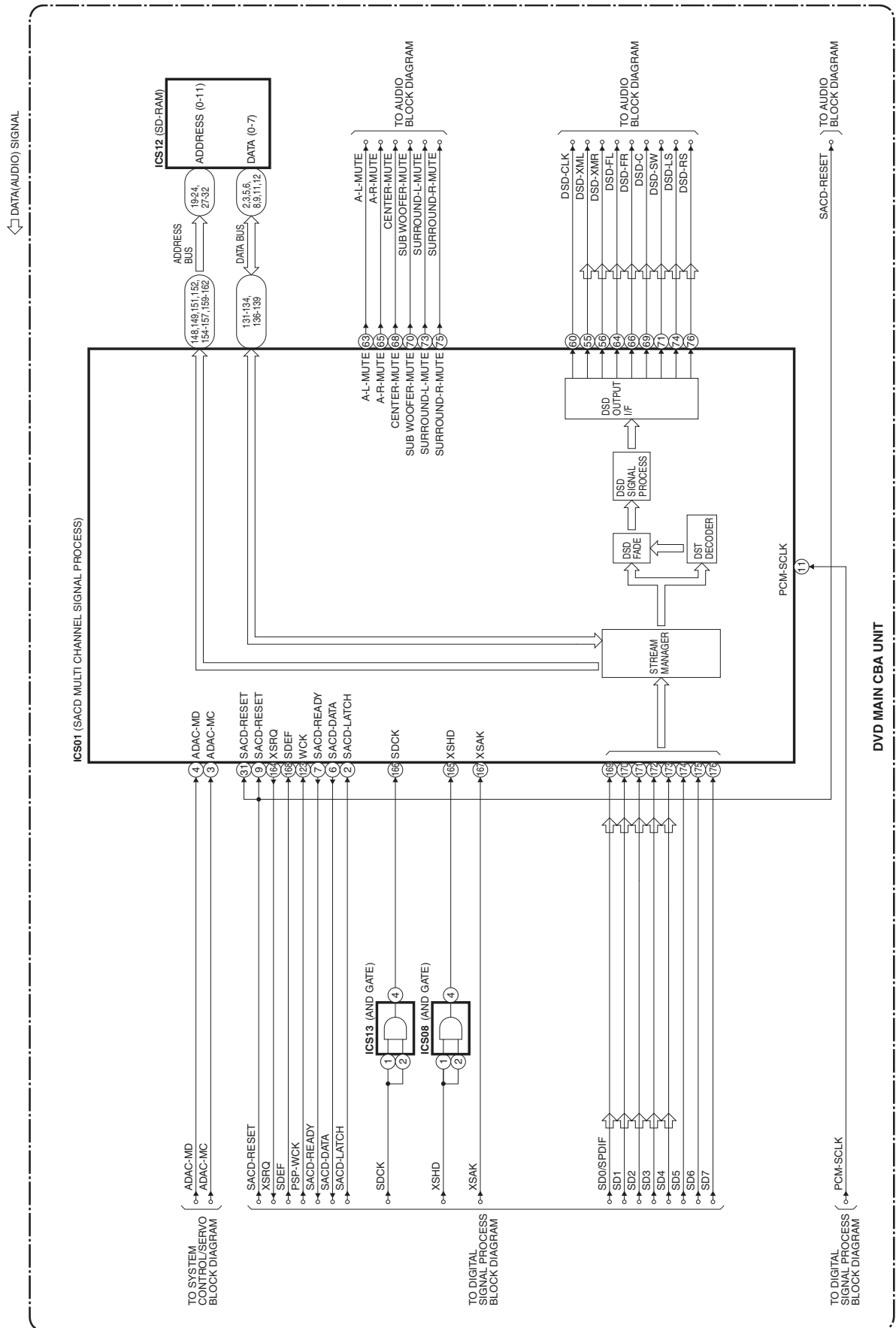



# Power Supply Block Diagram

**CAUTION !**

Fixed voltage (or Auto voltage selectable) power supply circuit is used in this unit.  
 If Main Fuse (F1001) is blown, check to see that all components in the power supply circuit are not defective before you connect the AC plug to the AC power supply.  
 Otherwise it may cause some components in the power supply circuit to fail.

**CAUTION !**

For continued protection against fire hazard, replace only with the same type fuse.

**NOTE:**

The voltage for parts in hot circuit is measured using hot GND as a common terminal.

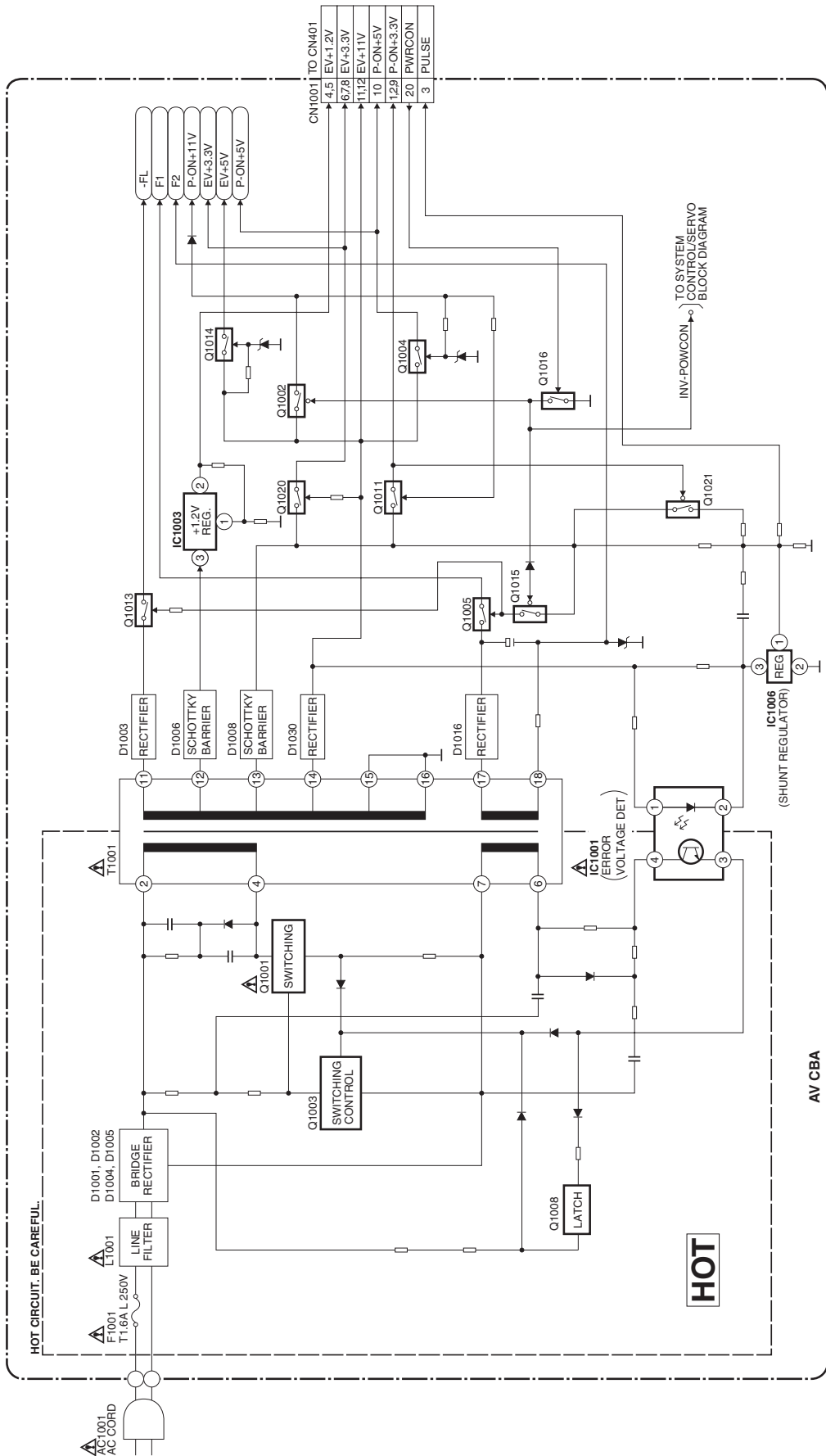

# SCHEMATIC DIAGRAMS / CBA'S AND TEST POINTS

## Standard Notes

### WARNING

Many electrical and mechanical parts in this chassis have special characteristics. These characteristics often pass unnoticed and the protection afforded by them cannot necessarily be obtained by using replacement components rated for higher voltage, wattage, etc. Replacement parts that have these special safety characteristics are identified in this manual and its supplements; electrical components having such features are identified by the mark “⚠” in the schematic diagram and the parts list. Before replacing any of these components, read the parts list in this manual carefully. The use of substitute replacement parts that do not have the same safety characteristics as specified in the parts list may create shock, fire, or other hazards.

### Notes:

1. Do not use the part number shown on these drawings for ordering. The correct part number is shown in the parts list, and may be slightly different or amended since these drawings were prepared.
2. All resistance values are indicated in ohms ( $K = 10^3$ ,  $M = 10^6$ ).
3. Resistor wattages are 1/4W or 1/6W unless otherwise specified.
4. All capacitance values are indicated in  $\mu F$  ( $P = 10^{-6} \mu F$ ).
5. All voltages are DC voltages unless otherwise specified.
6. Electrical parts such as capacitors, connectors, diodes, IC's, transistors, resistors, switches, and fuses are identified by four digits. The first two digits are not shown for each component. In each block of the diagram, there is a note such as shown below to indicate these abbreviated two digits.

## LIST OF CAUTION, NOTES, AND SYMBOLS USED IN THE SCHEMATIC DIAGRAMS ON THE FOLLOWING PAGES:

### 1. CAUTION:

FOR CONTINUED PROTECTION AGAINST FIRE HAZARD, REPLACE ONLY WITH THE SAME TYPE FUSE.

### 2. CAUTION:

Fixed Voltage (or Auto voltage selectable) power supply circuit is used in this unit.

If Main Fuse (F1001) is blown, first check to see that all components in the power supply circuit are not defective before you connect the AC plug to the AC power supply. Otherwise it may cause some components in the power supply circuit to fail.

### 3. Note:

- Do not use the part number shown on the drawings for ordering. The correct part number is shown in the parts list, and may be slightly different or amended since the drawings were prepared.
- To maintain original function and reliability of repaired units, use only original replacement parts which are listed with their part numbers in the parts list section of the service manual.

### 4. Voltage indications for PLAY and STOP mode on the schematics are as shown below:

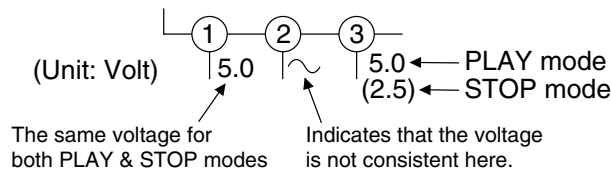

### 5. How to read converged lines

1-D3  
 Distinction Area  
 Line Number  
 (1 to 3 digits)

Examples:

- "1-D3" means that line number "1" goes to the line number "1" of the area "D3".
- "1-B1" means that line number "1" goes to the line number "1" of the area "B1".

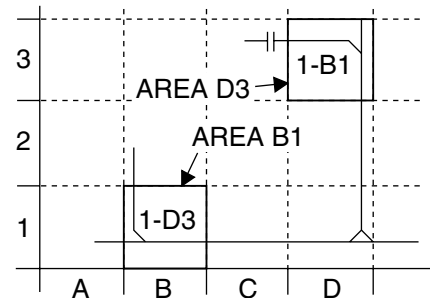

### 6. Test Point Information

: Indicates a test point with a jumper wire across a hole in the PCB.

: Used to indicate a test point with a component lead on foil side.

: Used to indicate a test point with no test pin.

: Used to indicate a test point with a test pin.

# DVD Main 1/7 Schematic Diagram

**\*1 NOTE:**  
Either IC461 or IC462 is used for DVD MAIN CBA UNIT.

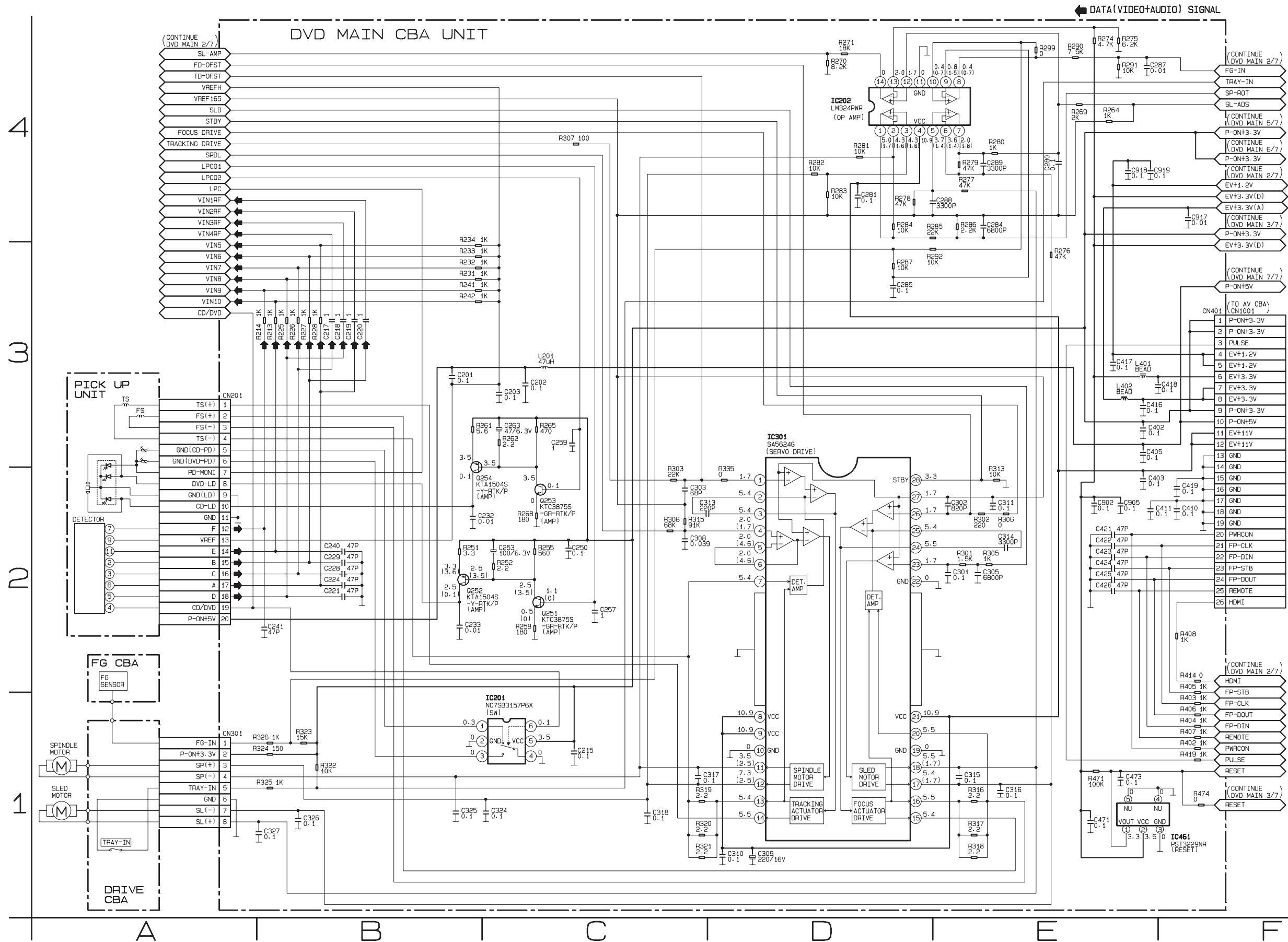



# IC101 Voltage Chart

~ : Voltage is not consistent    ---- : Not used    Unit : Volts

| PIN.NO | PLAY | STOP | PIN.NO | PLAY | STOP | PIN.NO | PLAY | STOP | PIN.NO | PLAY | STOP | PIN.NO | PLAY | STOP | PIN.NO | PLAY | STOP | PIN.NO | PLAY | STOP | PIN.NO | PLAY | STOP |
|--------|------|------|--------|------|------|--------|------|------|--------|------|------|--------|------|------|--------|------|------|--------|------|------|--------|------|------|
| 1      | 3.4  | 3.4  | 33     | ~    | ~    | 65     | ~    | ~    | 97     | 0    | 0    | 129    | 2.3  | 2.3  | 161    | 0    | 0    | 193    | 3.2  | 3.2  | 225    | 1.9  | 1.9  |
| 2      | 0    | 0    | 34     | 0    | 0    | 66     | 3.4  | 3.4  | 98     | 0    | 0    | 130    | 2.3  | 2.3  | 162    | 1.7  | 1.7  | 194    | 3.2  | 3.2  | 226    | 0    | 0    |
| 3      | 3.5  | 3.5  | 35     | 3.5  | 3.5  | 67     | 3.4  | 3.4  | 99     | 0    | 0    | 131    | 2.3  | 2.3  | 163    | 1.7  | 1.7  | 195    | 1.7  | 1.7  | 227    | 3.2  | 3.2  |
| 4      | 3.5  | 3.5  | 36     | ~    | ~    | 68     | 0    | 0    | 100    | 0    | 0    | 132    | 2.4  | 2.3  | 164    | 0    | 0    | 196    | 0    | 0    | 228    | 3.3  | 3.3  |
| 5      | 0    | 0    | 37     | ~    | ~    | 69     | 3.5  | 3.5  | 101    | 0    | 0    | 133    | 2.4  | 2.4  | 165    | 1.3  | 1.3  | 197    | 3.5  | 3.5  | 229    | 3.0  | 3.0  |
| 6      | ---- | ---- | 38     | ~    | ~    | 70     | 3.6  | 3.4  | 102    | 3.5  | 3.5  | 134    | 2.4  | 2.4  | 166    | 3.2  | 3.2  | 198    | ~    | ~    | 230    | ~    | ~    |
| 7      | 3.3  | 0.8  | 39     | ~    | ~    | 71     | 3.2  | 3.2  | 103    | 0.9  | 0.8  | 135    | 2.3  | 2.3  | 167    | 3.2  | 3.2  | 199    | ~    | ~    | 231    | 1.6  | 1.6  |
| 8      | 3.5  | 3.5  | 40     | ~    | ~    | 72     | 3.5  | 0.1  | 104    | 0    | 0    | 136    | 2.3  | 2.3  | 168    | 0    | 0    | 200    | ~    | ~    | 232    | ~    | ~    |
| 9      | 0    | 0    | 41     | ~    | ~    | 73     | 3.5  | 3.5  | 105    | 2.4  | 2.4  | 137    | 2.3  | 2.3  | 169    | 0    | 0    | 201    | ~    | ~    | 233    | 0    | 0    |
| 10     | ---- | ---- | 42     | ~    | ~    | 74     | 3.4  | 3.4  | 106    | 1.9  | 1.9  | 138    | 2.3  | 2.3  | 170    | 0    | 0    | 202    | ~    | ~    | 234    | 1.3  | 1.3  |
| 11     | 3.4  | 3.4  | 43     | ~    | ~    | 75     | 3.4  | 3.4  | 107    | 0.4  | 0.3  | 139    | 2.1  | 1.7  | 171    | 0    | 0    | 203    | ~    | ~    | 235    | 1.4  | 1.4  |
| 12     | ---- | ---- | 44     | 0    | 0    | 76     | 3.2  | 3.2  | 108    | 0    | 0    | 140    | 1.7  | 1.7  | 172    | 0    | 0    | 204    | 3.5  | 3.5  | 236    | ~    | ~    |
| 13     | 0.1  | 0.1  | 45     | 1.3  | 1.3  | 77     | 3.5  | 3.5  | 109    | 1.7  | 1.7  | 141    | 1.7  | 1.7  | 173    | 3.2  | 3.2  | 205    | 0    | 0    | 237    | ~    | ~    |
| 14     | 1.6  | 1.6  | 46     | ~    | ~    | 78     | 3.4  | 3.4  | 110    | 3.5  | 3.5  | 142    | 1.7  | 1.7  | 174    | 0    | 0    | 206    | ~    | ~    | 238    | 0    | 0    |
| 15     | 3.4  | 3.4  | 47     | ~    | ~    | 79     | 2.2  | 2.2  | 111    | ---- | ---- | 143    | 0    | 0    | 175    | 3.5  | 3.5  | 207    | ~    | ~    | 239    | 3.5  | 3.5  |
| 16     | 0    | 0    | 48     | ~    | ~    | 80     | 3.2  | 3.2  | 112    | ---- | ---- | 144    | 1.7  | 1.7  | 176    | 1.3  | 1.3  | 208    | ~    | ~    | 240    | ~    | ~    |
| 17     | 3.5  | 3.5  | 49     | ~    | ~    | 81     | 3.5  | 3.5  | 113    | 1.9  | 1.9  | 145    | 1.7  | 1.7  | 177    | 1.3  | 1.3  | 209    | ~    | ~    | 241    | ~    | ~    |
| 18     | ~    | ~    | 50     | ~    | ~    | 82     | 0    | 0    | 114    | 1.9  | 1.9  | 146    | 3.5  | 3.5  | 178    | 1.3  | 1.3  | 210    | ~    | ~    | 242    | ~    | ~    |
| 19     | 2.4  | 2.8  | 51     | ~    | ~    | 83     | 1.3  | 1.3  | 115    | 1.7  | 1.7  | 147    | ---- | ---- | 179    | 1.5  | 1.5  | 211    | ~    | ~    | 243    | ~    | ~    |
| 20     | 2.4  | 2.8  | 52     | 0    | 0    | 84     | 3.3  | 3.3  | 116    | 1.7  | 1.7  | 148    | ---- | ---- | 180    | 1.0  | 1.0  | 212    | ~    | ~    | 244    | ~    | ~    |
| 21     | 0    | 0    | 53     | 3.5  | 3.5  | 85     | 1.4  | 2.7  | 117    | 1.7  | 1.7  | 149    | ---- | ---- | 181    | 1.0  | 1.0  | 213    | ~    | ~    | 245    | ~    | ~    |
| 22     | 1.3  | 1.3  | 54     | ~    | ~    | 86     | 0.1  | 0.1  | 118    | 1.7  | 1.7  | 150    | 3.5  | 3.5  | 182    | 1.0  | 1.0  | 214    | 3.5  | 3.5  | 246    | ~    | ~    |
| 23     | ~    | ~    | 55     | 3.4  | 3.4  | 87     | 0    | 0    | 119    | 3.5  | 3.5  | 151    | 2.2  | 2.2  | 183    | 1.0  | 1.0  | 215    | 0    | 0    | 247    | ~    | ~    |
| 24     | ~    | ~    | 56     | ~    | ~    | 88     | 3.4  | 0    | 120    | 2.0  | 2.0  | 152    | 1.4  | 1.3  | 184    | 3.5  | 3.5  | 216    | ~    | ~    | 248    | 0    | 0    |
| 25     | ~    | ~    | 57     | ~    | ~    | 89     | 3.4  | 3.5  | 121    | 1.5  | 1.5  | 153    | 1.4  | 1.3  | 185    | 0    | 0    | 217    | ~    | ~    | 249    | 3.5  | 3.5  |
| 26     | ~    | ~    | 58     | ~    | ~    | 90     | 2.3  | 1.8  | 122    | 0    | 0    | 154    | 2.2  | 2.2  | 186    | 1.5  | 1.5  | 218    | 1.3  | 1.3  | 250    | ---- | ---- |
| 27     | ~    | ~    | 59     | ~    | ~    | 91     | 1.7  | 1.8  | 123    | 0.3  | 0.1  | 155    | 0    | 0    | 187    | 3.3  | 3.3  | 219    | 2.4  | 2.1  | 251    | ---- | ---- |
| 28     | ~    | ~    | 60     | ~    | ~    | 92     | 0    | 0    | 124    | 1.1  | 0    | 156    | 0.6  | 0.6  | 188    | 3.3  | 3.3  | 220    | 2.4  | 2.1  | 252    | 3.4  | 3.4  |
| 29     | ~    | ~    | 61     | ~    | ~    | 93     | 3.5  | 3.5  | 125    | 0.3  | 0.1  | 157    | 0.9  | 0.9  | 189    | 0    | 0    | 221    | 3.3  | 3.3  | 253    | 2.8  | 2.8  |
| 30     | ~    | ~    | 62     | ~    | ~    | 94     | 0    | 0    | 126    | 0.1  | 0.1  | 158    | 3.5  | 3.5  | 190    | 1.6  | 1.6  | 222    | 0    | 0    | 254    | 3.3  | 3.3  |
| 31     | ~    | ~    | 63     | ~    | ~    | 95     | 0    | 0    | 127    | 2.3  | 2.3  | 159    | 0    | 0    | 191    | 3.3  | 3.3  | 223    | 1.6  | 1.6  | 255    | 3.4  | 3.4  |
| 32     | ~    | ~    | 64     | ~    | ~    | 96     | 0    | 0    | 128    | 1.7  | 1.7  | 160    | 3.5  | 3.5  | 192    | 3.2  | 3.2  | 224    | 3.5  | 3.5  | 256    | 3.4  | 3.4  |

# DVD Main 3/7 Schematic Diagram

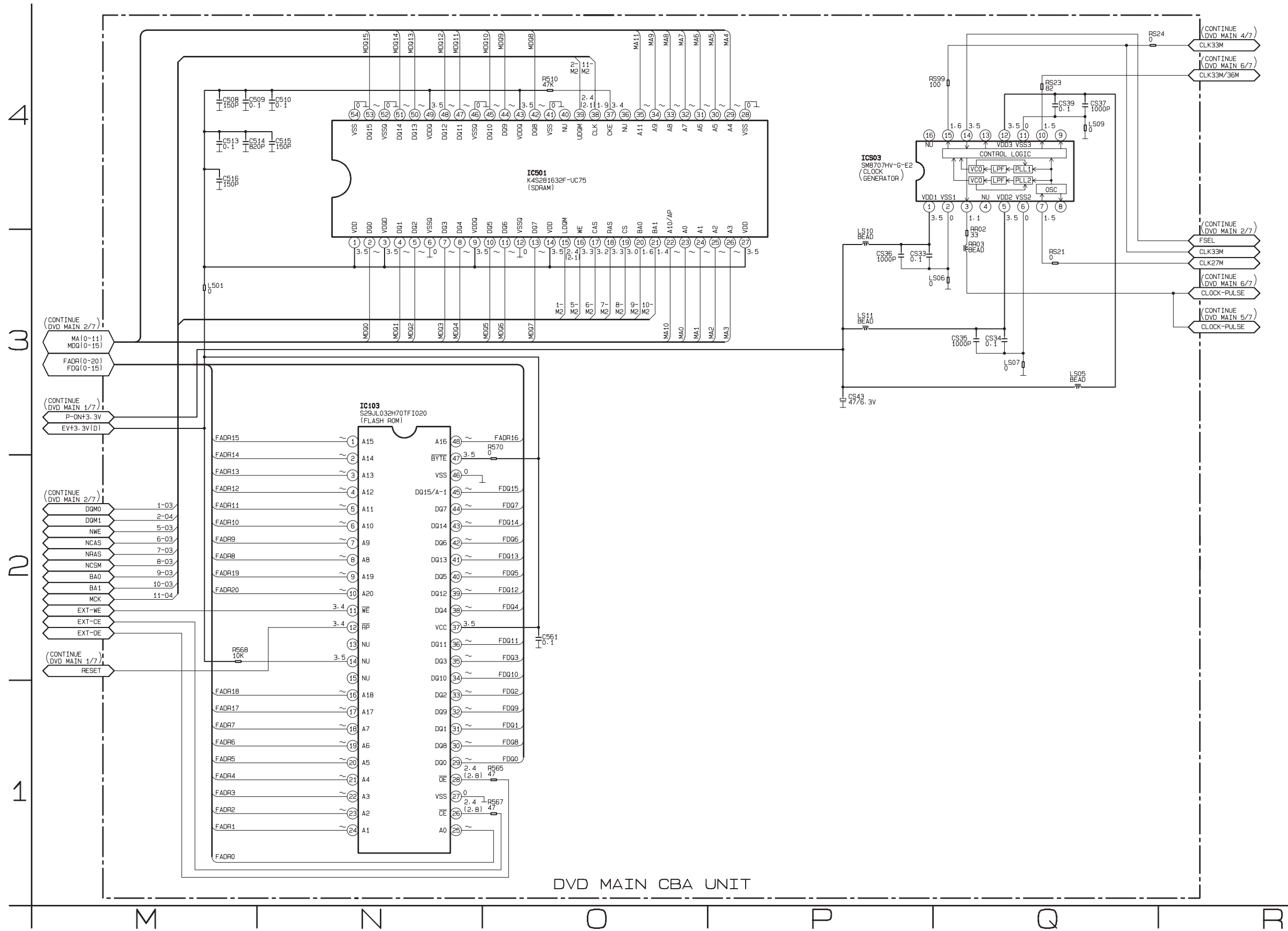

DVD MAIN CBA UNIT

# DVD Main 4/7 Schematic Diagram

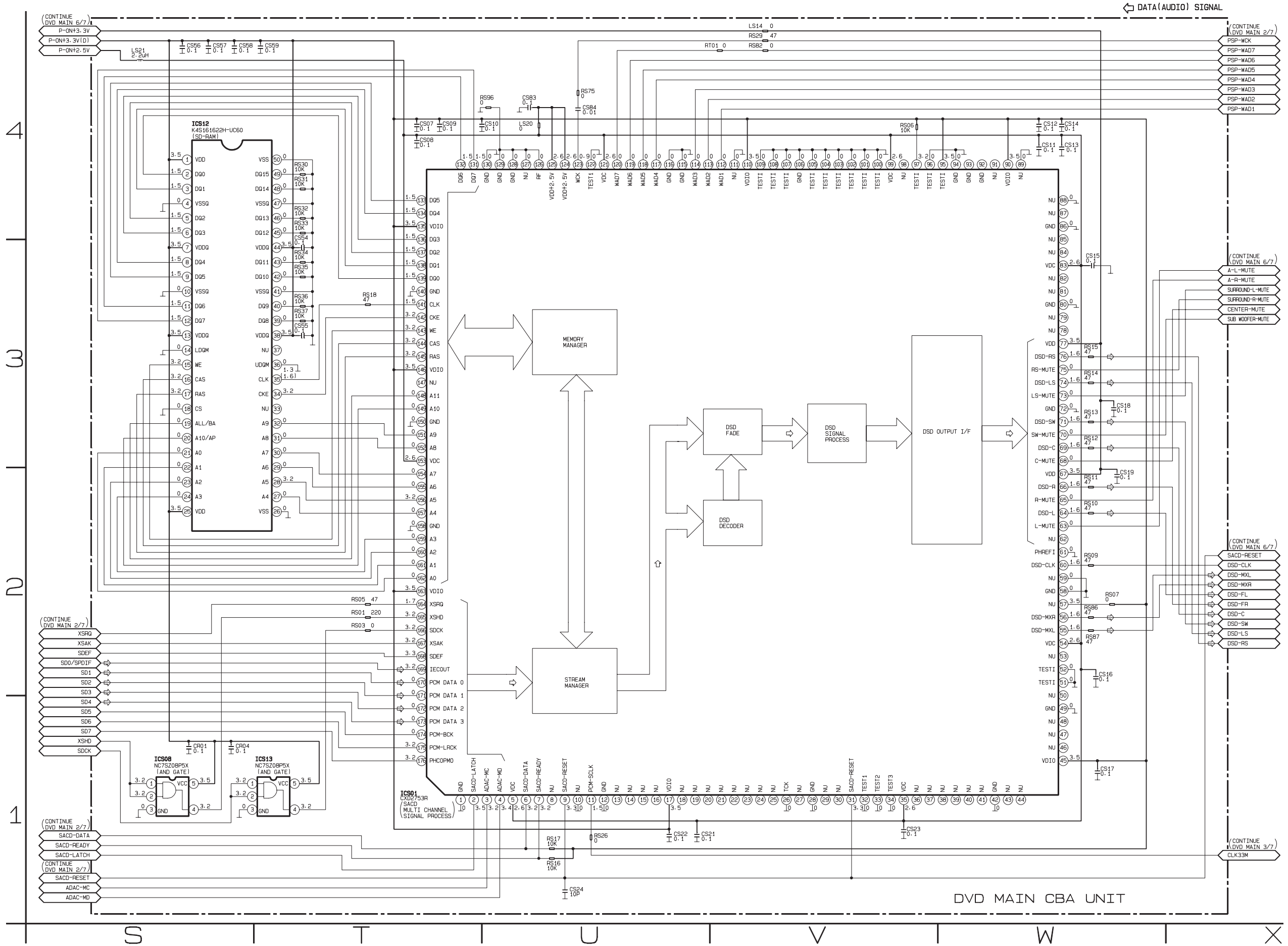



# DVD Main 5/7 Schematic Diagram

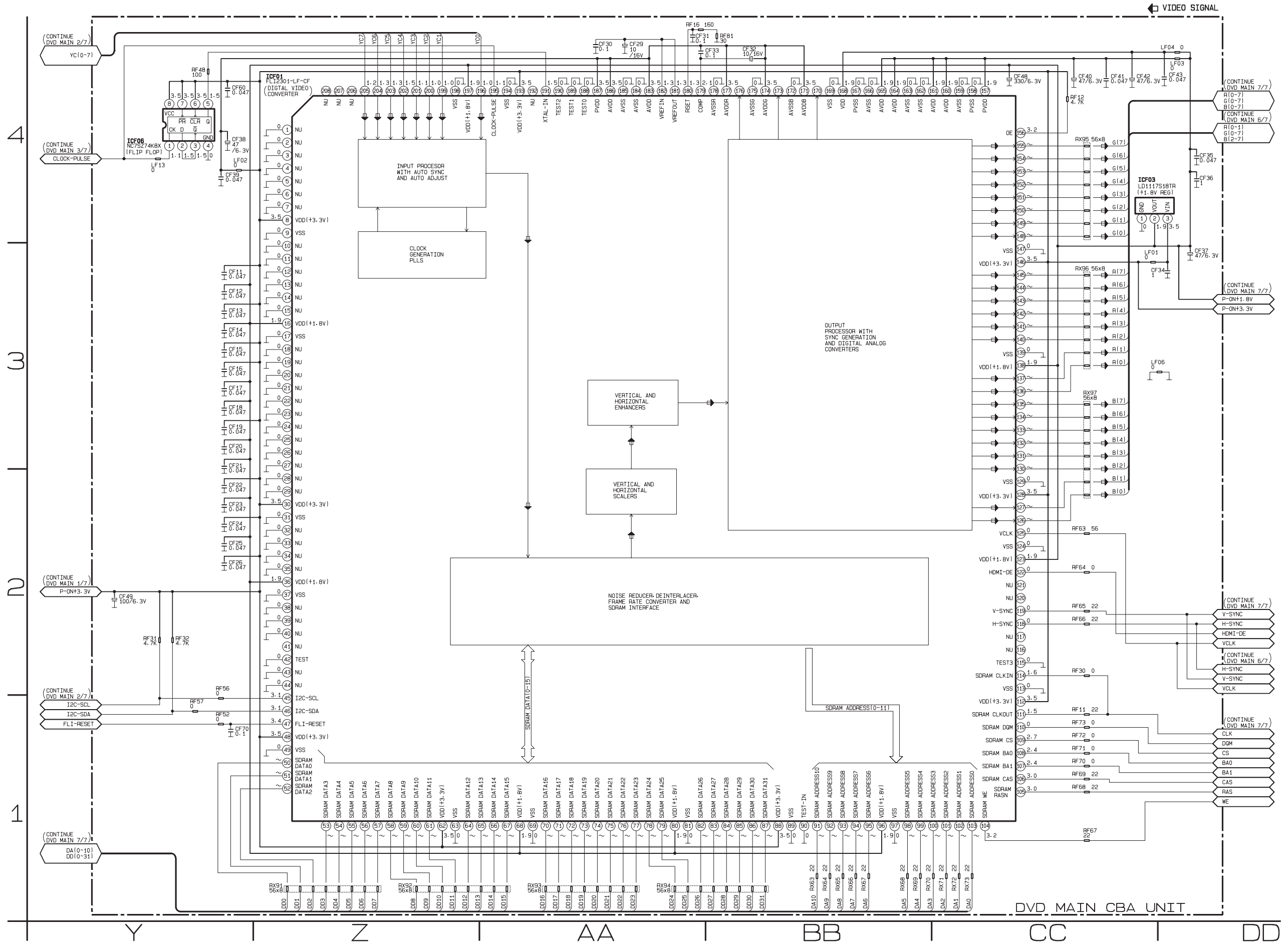

# DVD Main 6/7 Schematic Diagram

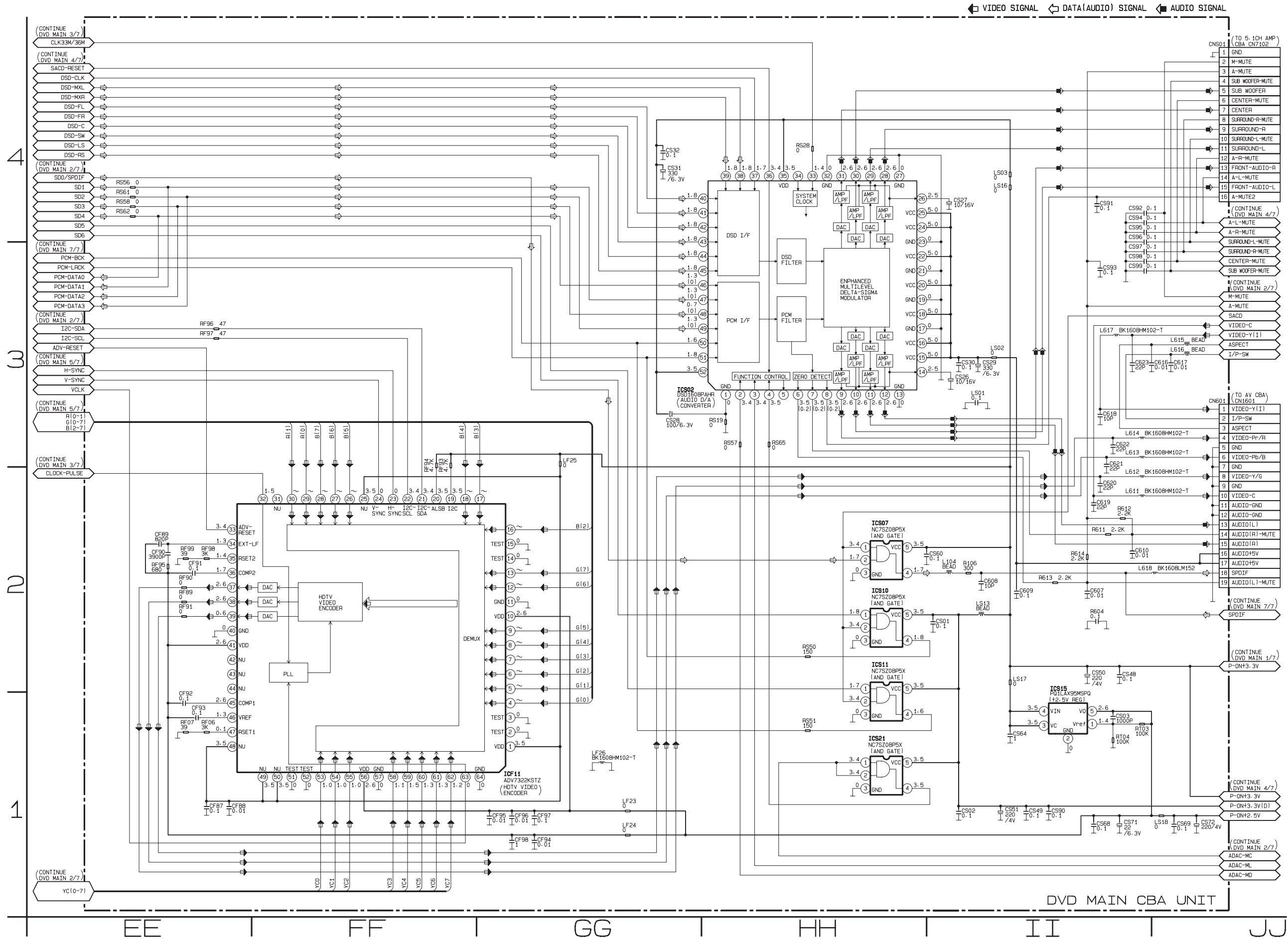

# DVD Main 7/7 Schematic Diagram

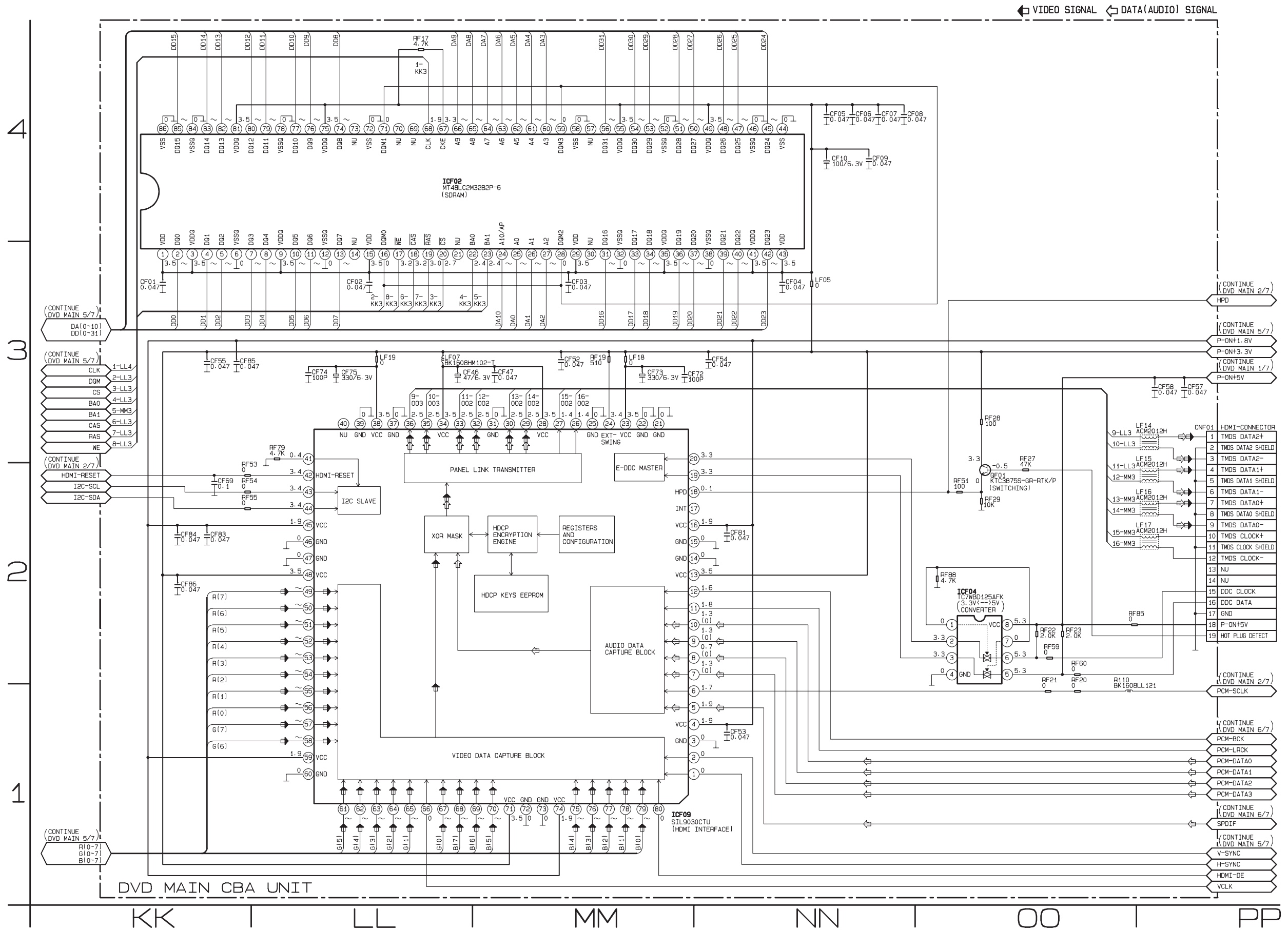

# AV 1/3 Schematic Diagram

## CAUTION !

Fixed voltage (or Auto voltage selectable) power supply circuit is used in this unit.  
 If Main Fuse (F1001) is blown , check to see that all components in the power supply circuit are not defective before you connect the AC plug to the AC power supply.  
 Otherwise it may cause some components in the power supply circuit to fail.

## NOTE:

The voltage for parts in hot circuit is measured using hot GND as a common terminal.

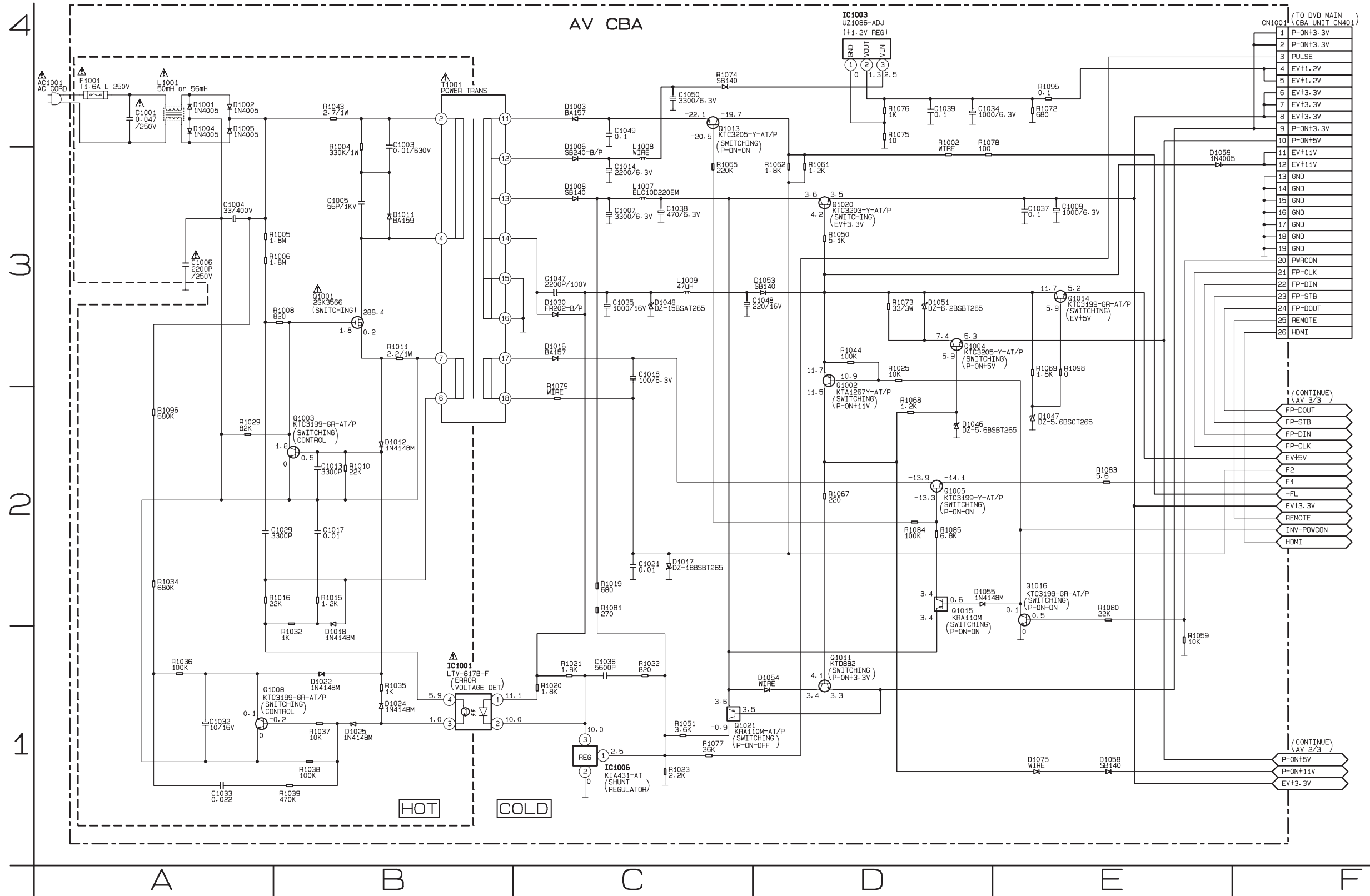

# AV 2/3 Schematic Diagram

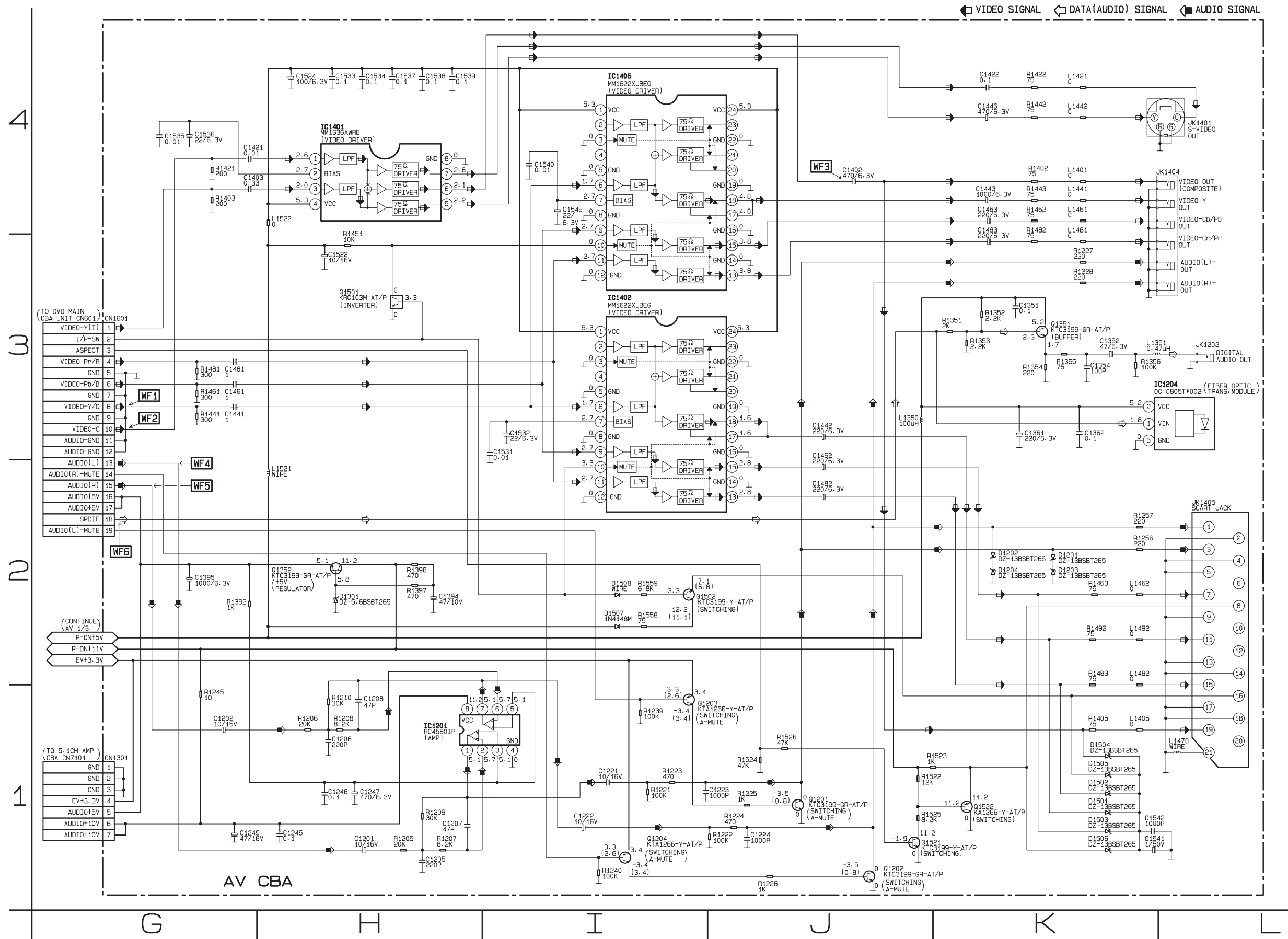

# AV 3/3, Function & LED Schematic Diagram

FL2001 MATRIX CHART

|   | 7G     | 6G    | 5G | 4G   | 3G   | 2G | 1G    |
|---|--------|-------|----|------|------|----|-------|
| a |        | a     | a  | a    | a    | a  | SACD  |
| b | REPEAT | b     | b  | b    | b    | b  | PSCAN |
| c | A-     | c     | c  | c    | c    | c  | DVD   |
| d | B      | d     | d  | d    | d    | d  | A     |
| e | ALL    | e     | e  | e    | e    | e  | P     |
| f |        | f     | f  | f    | f    | f  | M     |
| g |        | g     | g  | g    | g    | g  | HD    |
| h |        | GROUP |    | CHP. | TRK. | V  |       |
| i | TITLE  | VCR   | .  |      | REC  | CD |       |

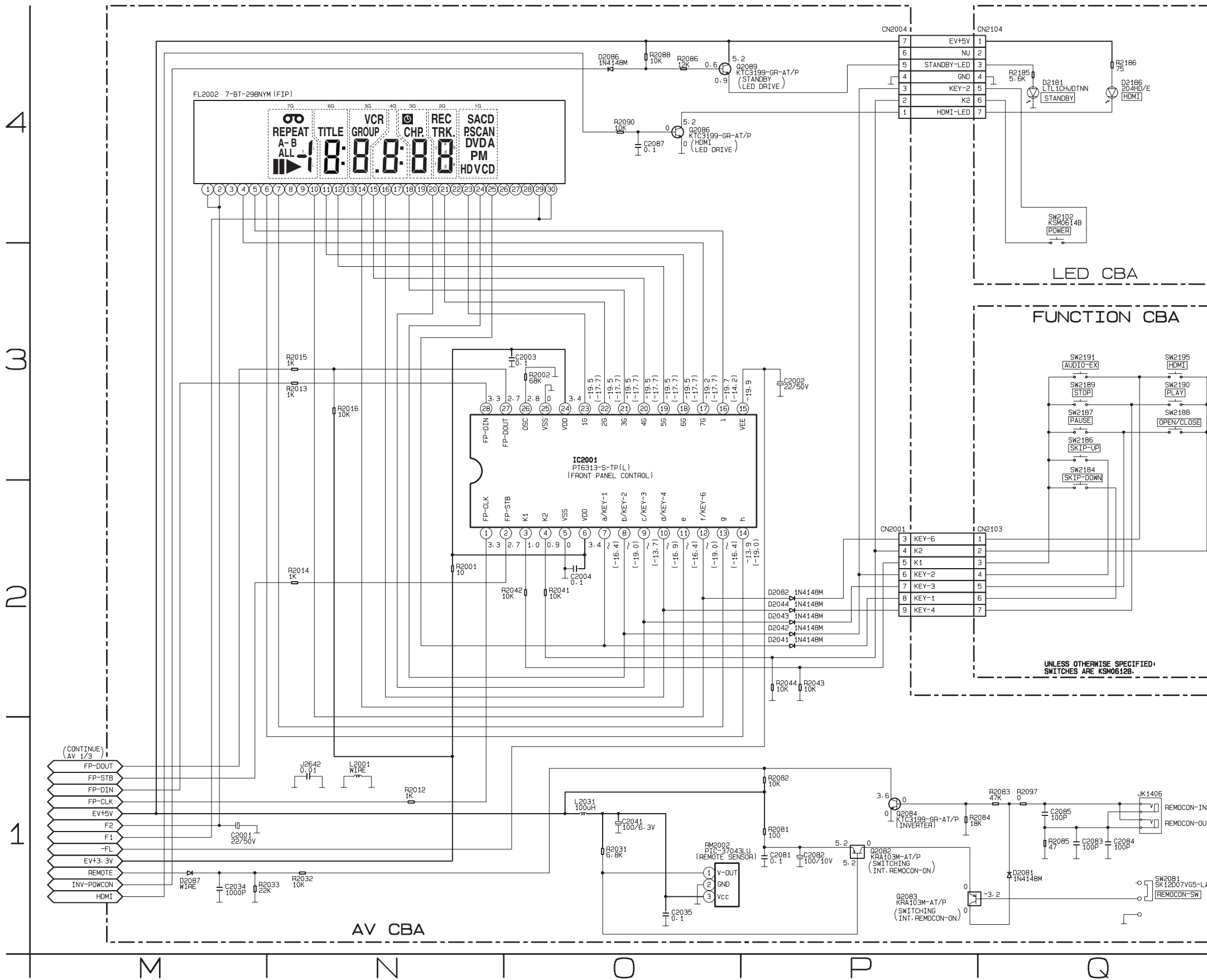

# 5.1CH AMP Schematic Diagram

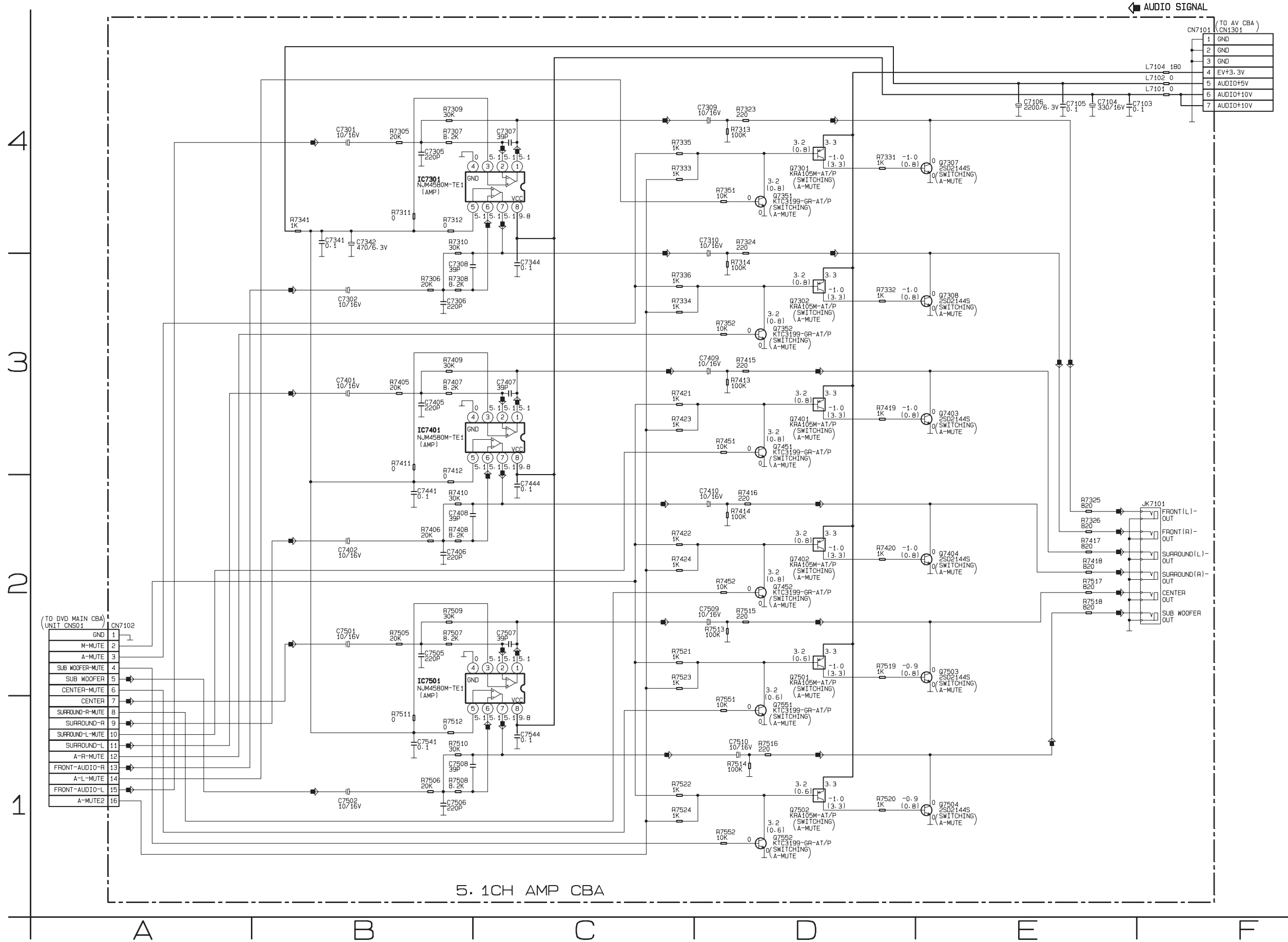

# AV CBA Top View

## CAUTION !

Fixed voltage (or Auto voltage selectable) power supply circuit is used in this unit.  
 If Main Fuse (F1001) is blown , check to see that all components in the power supply circuit are not defective before you connect the AC plug to the AC power supply.  
 Otherwise it may cause some components in the power supply circuit to fail.

## CAUTION !

For continued protection against fire hazard,  
 replace only with the same type fuse.

## NOTE:

The voltage for parts in hot circuit is measured using  
 hot GND as a common terminal.

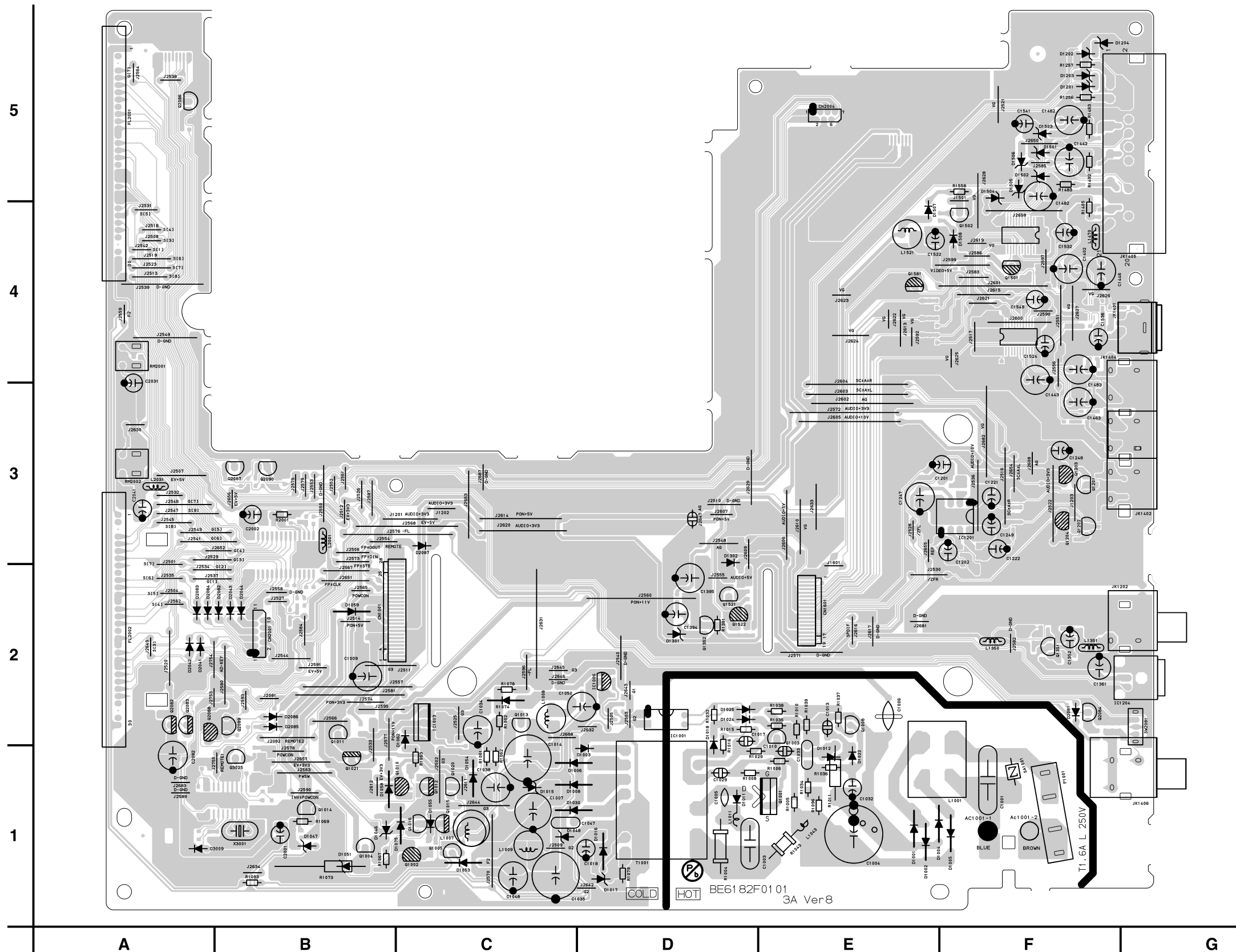



# AV CBA Bottom View

## CAUTION !

Fixed voltage (or Auto voltage selectable) power supply circuit is used in this unit.  
If Main Fuse (F1001) is blown, check to see that all components in the power supply circuit are not defective before you connect the AC plug to the AC power supply.  
Otherwise it may cause some components in the power supply circuit to fail.

## CAUTION !

For continued protection against fire hazard,  
replace only with the same type fuse.

## NOTE:

The voltage for parts in hot circuit is measured using  
hot GND as a common terminal.

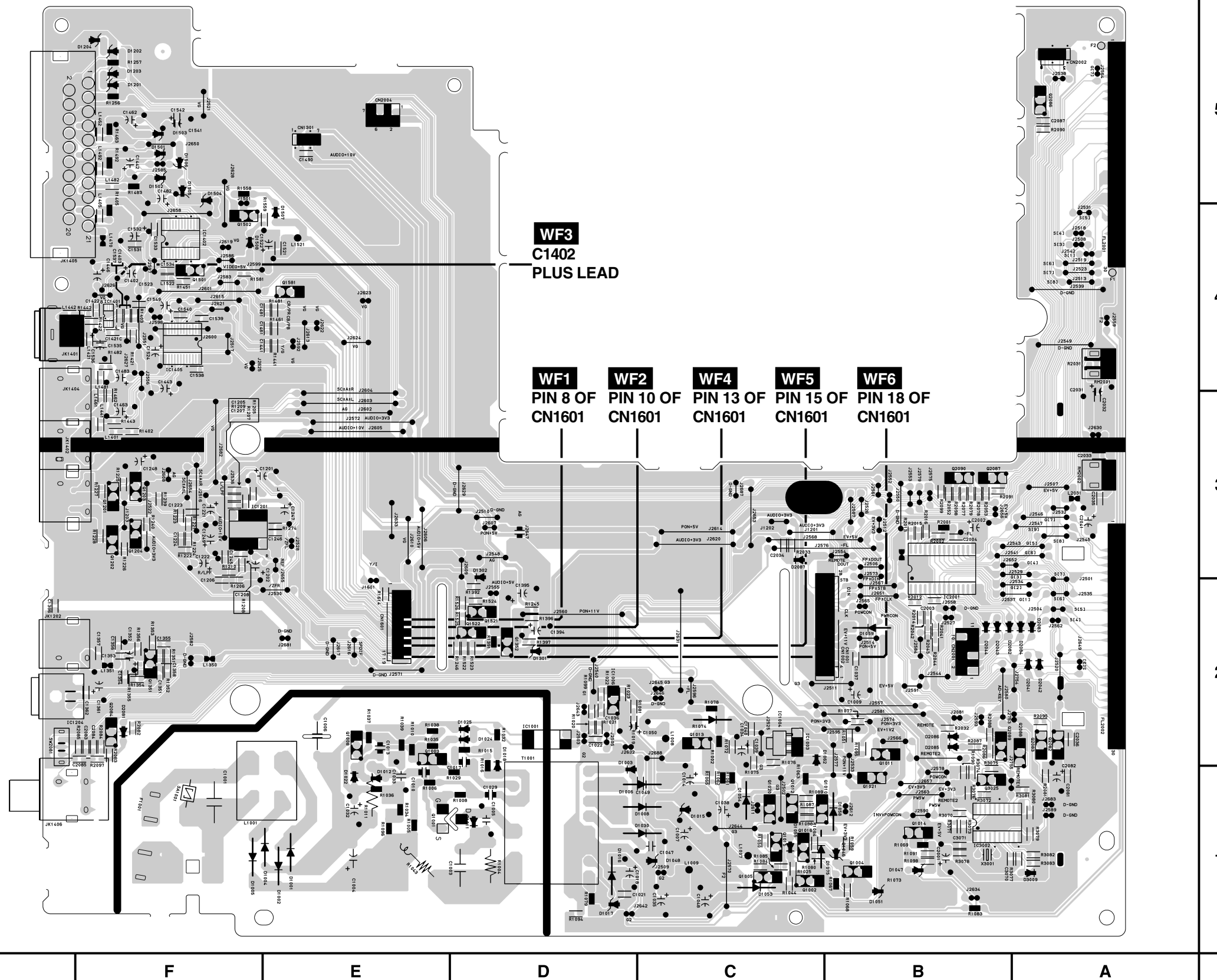

# FUNCTION CBA Top View

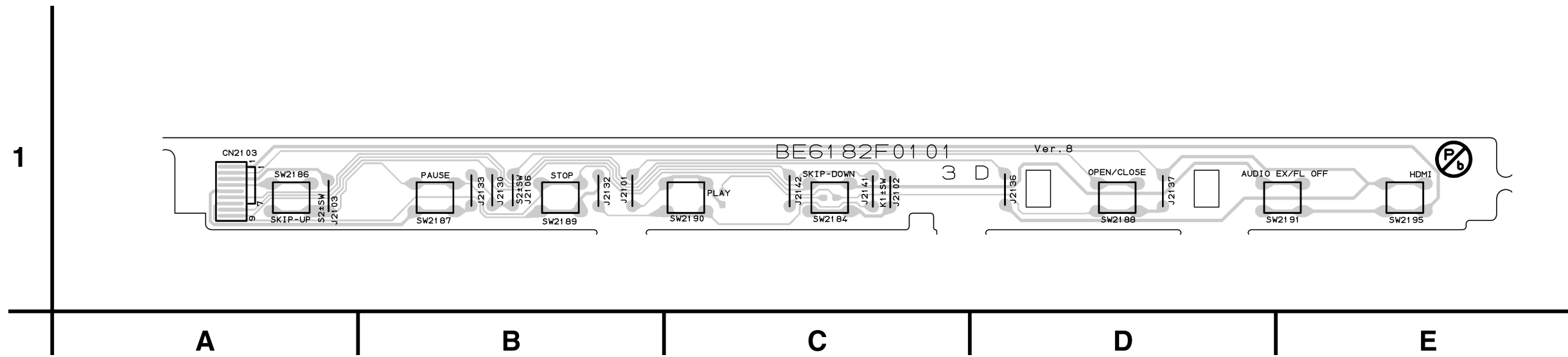

# FUNCTION CBA Bottom View

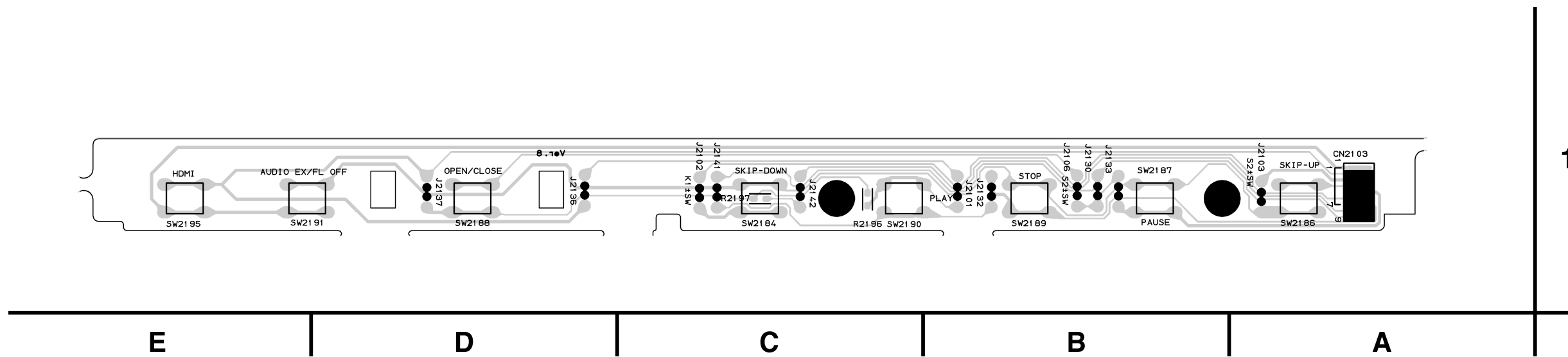

# LED CBA Top View

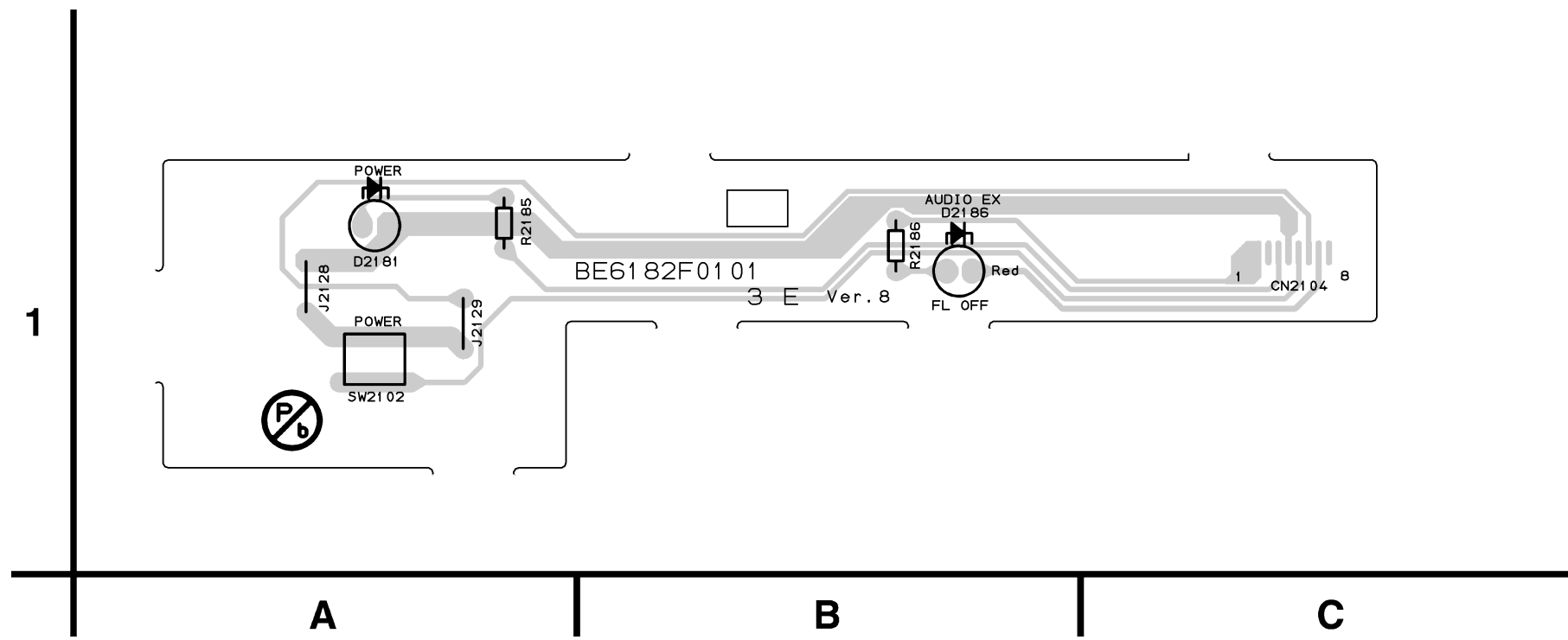

# LED CBA Bottom View

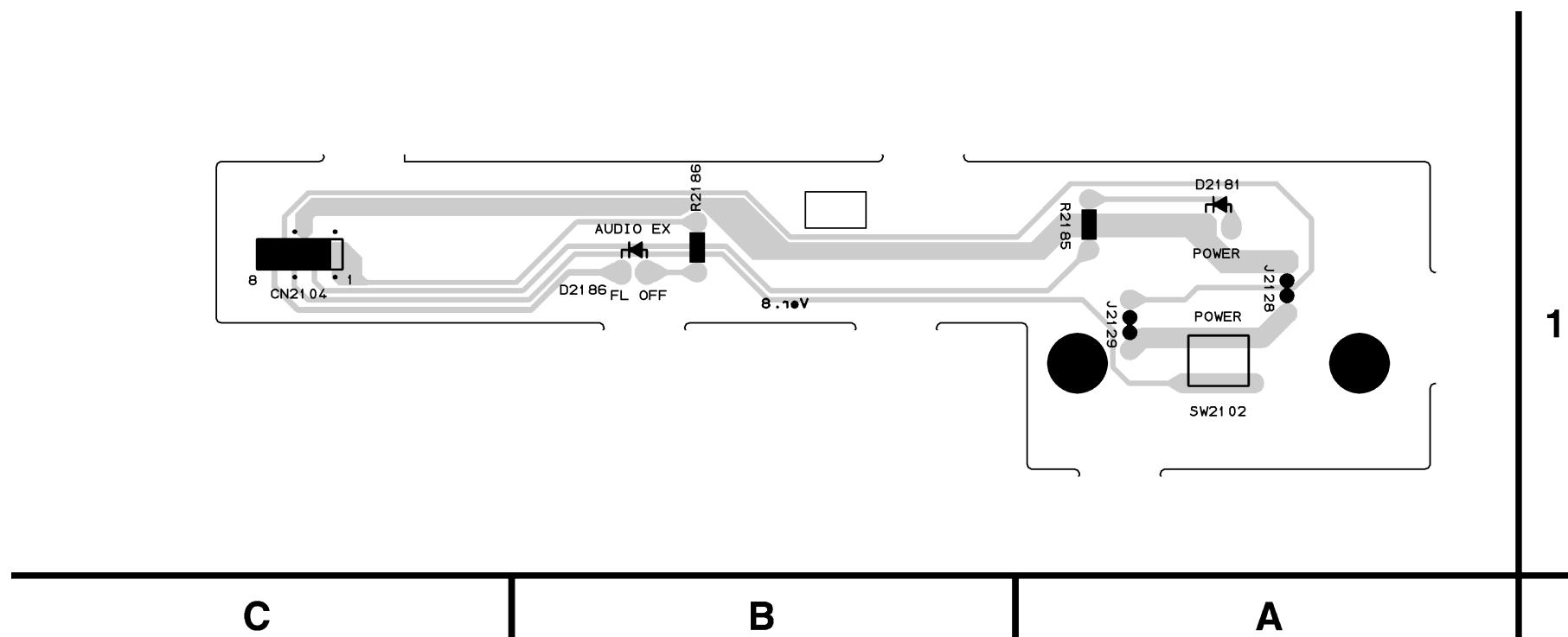

### 5.1CH AMP CBA Top View

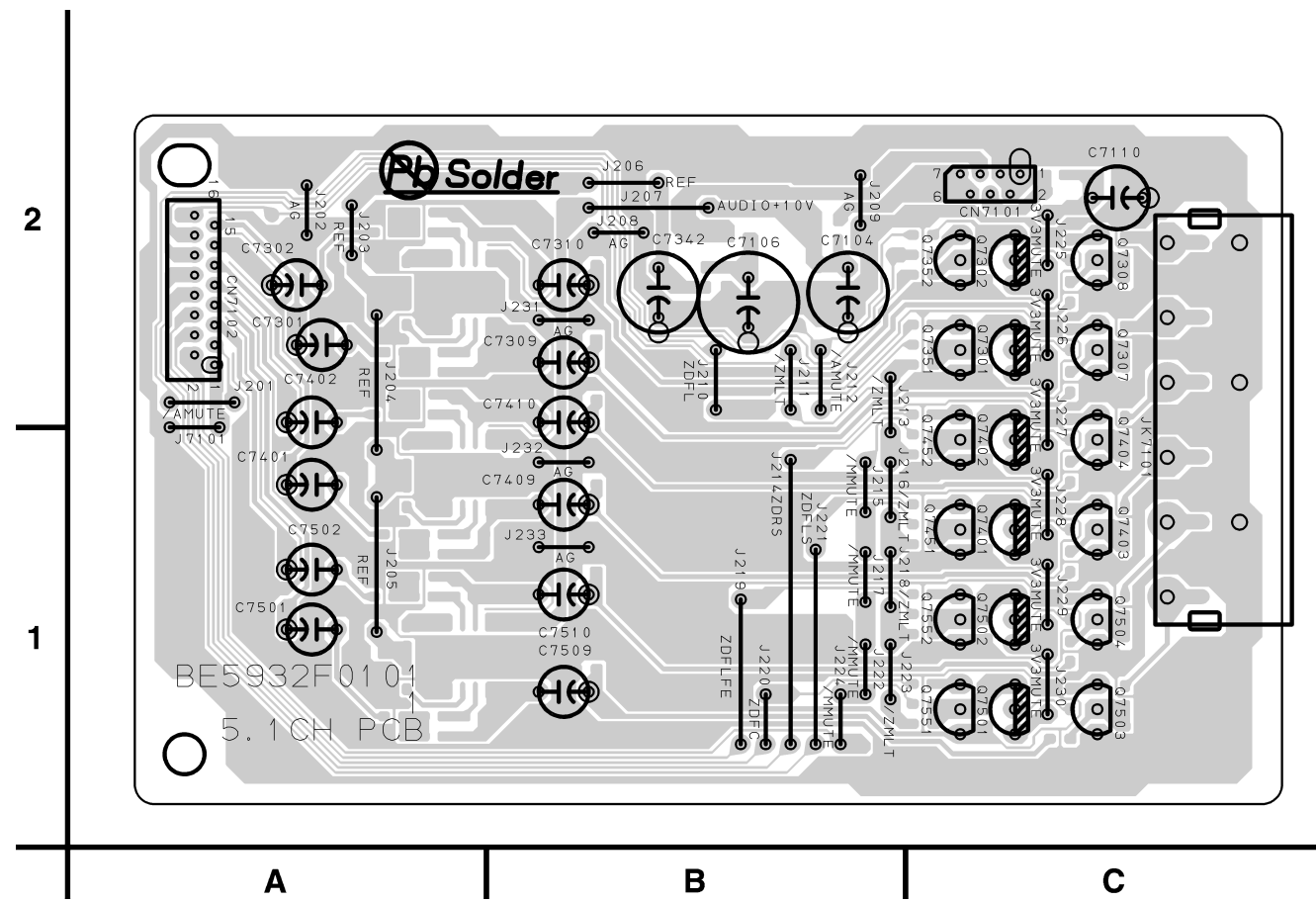

### 5.1CH AMP CBA Bottom View

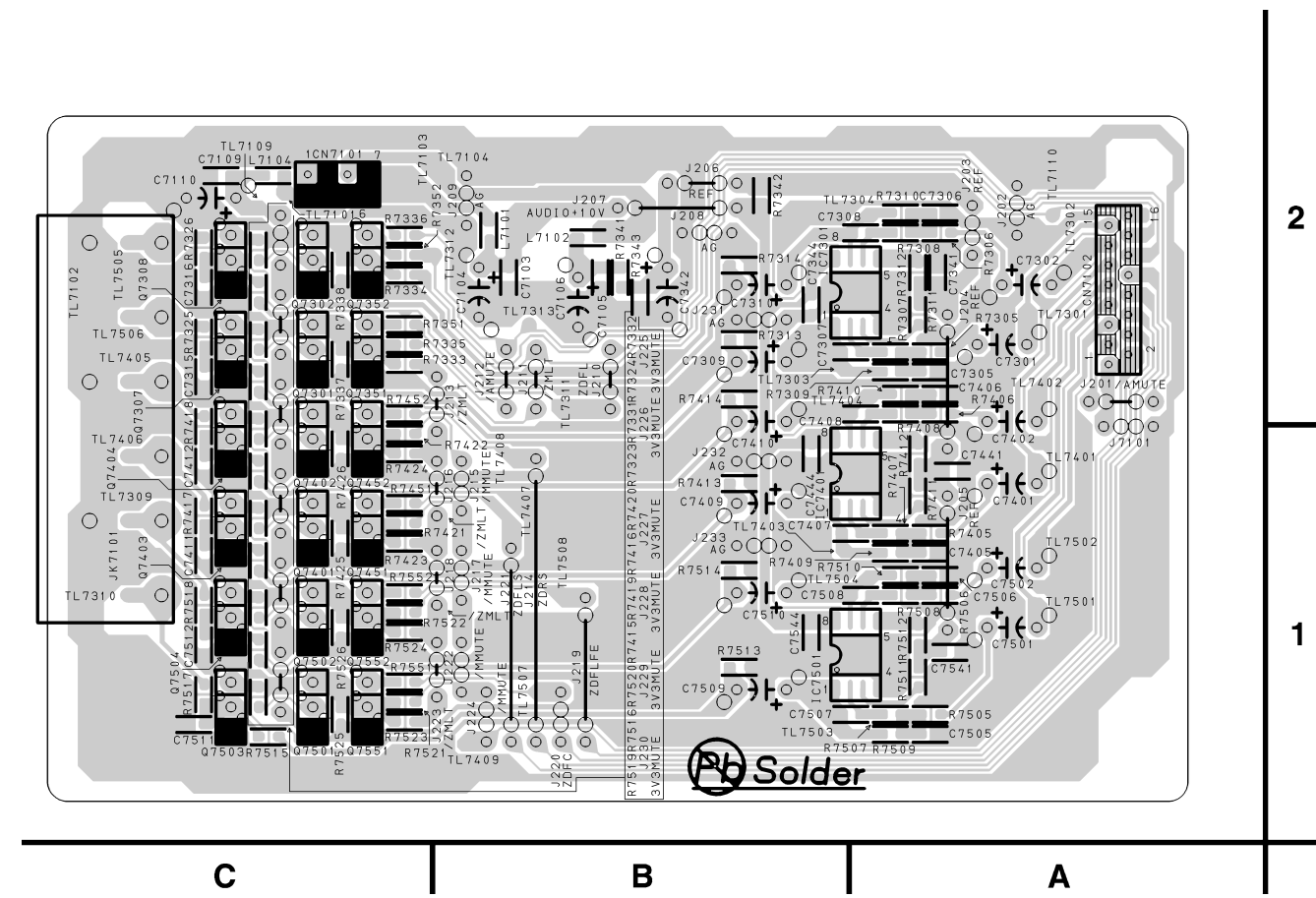

# WAVEFORMS

**WF1** Pin 8 of CN1601

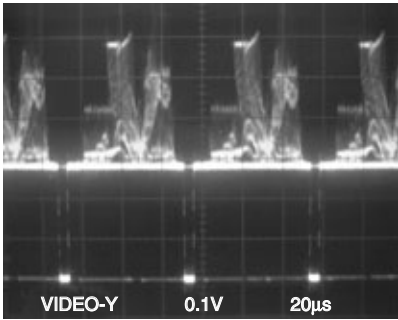

**WF5** Pin 15 of CN1601

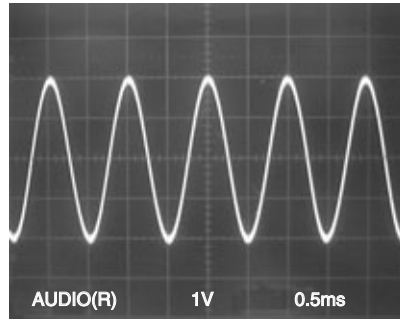

**WF2** Pin 10 of CN1601

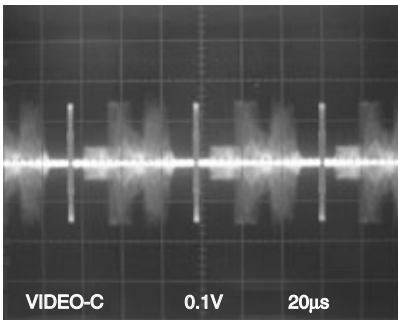

**WF6** Pin 18 of CN1601

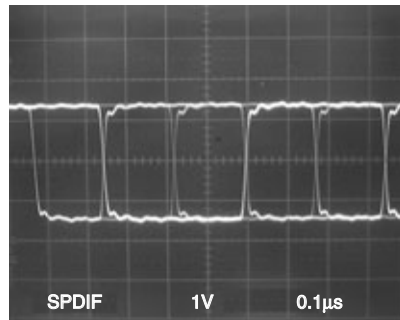

**WF3** C1402 PLUS LEAD

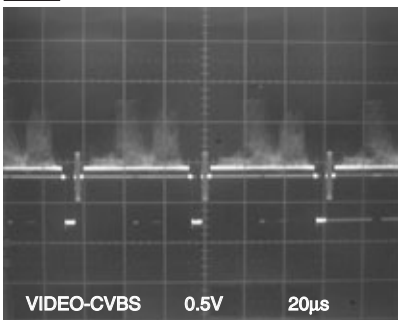

## NOTE:

Input

CD: 1kHz PLAY  
(WF4~WF6)

DVD: POWER ON (STOP) MODE  
(WF1~WF3)

**WF4** Pin 13 of CN1601

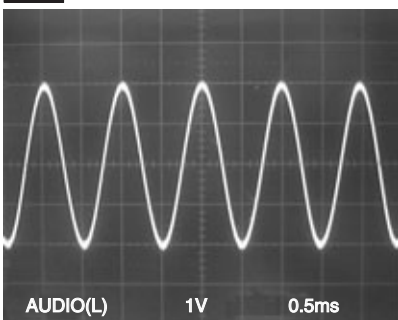

# WIRING DIAGRAM

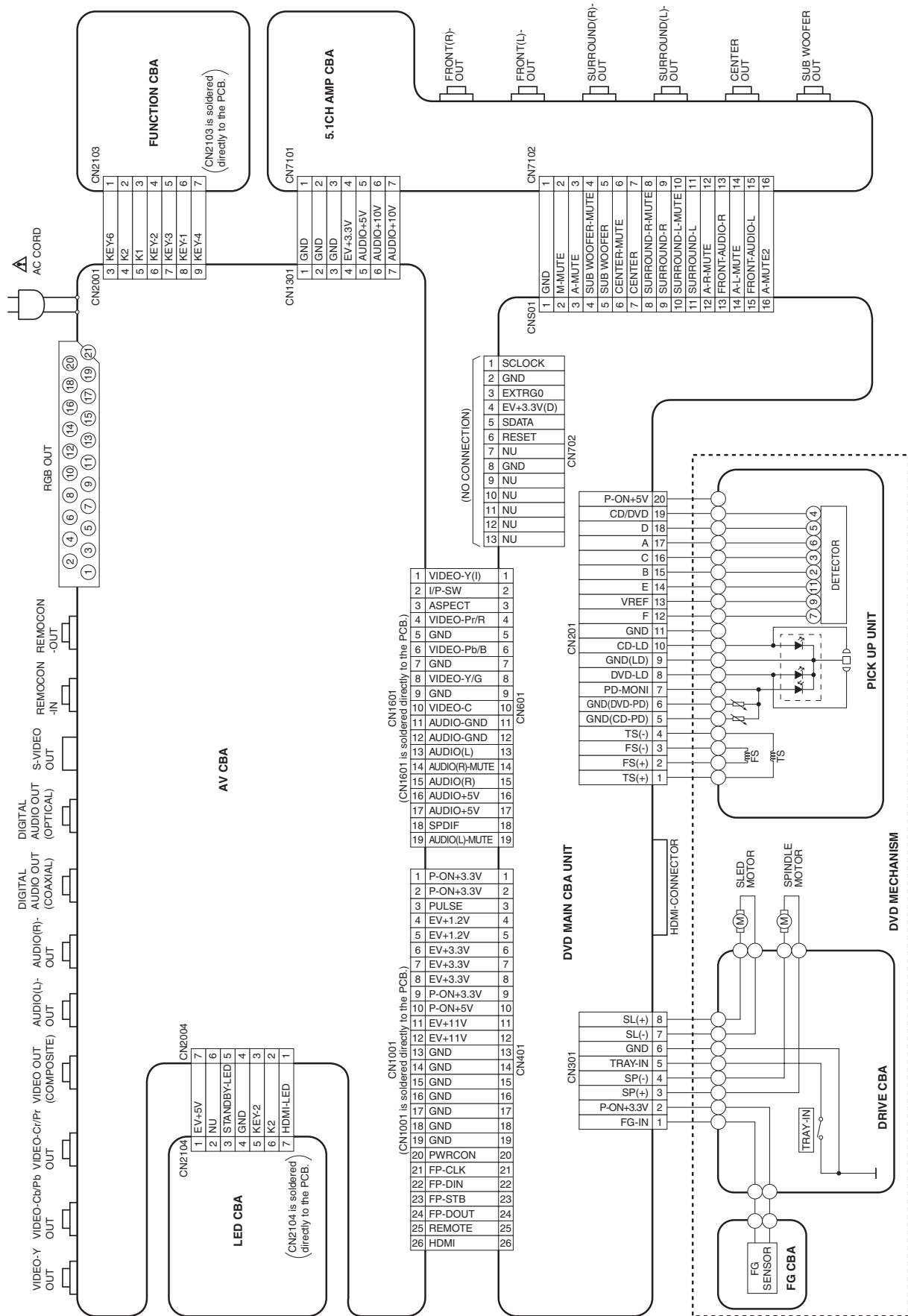

# IC PIN FUNCTION DESCRIPTIONS

## IC2001 [ PT6313-S-TP(L) ]

| Pin No. | In/Out | Signal Name | Name Function                 |
|---------|--------|-------------|-------------------------------|
| 1       | In     | FP-CLK      | Clock Input                   |
| 2       | In     | FP-STB      | Serial Interface Strobe       |
| 3       | In     | K1          | Key Data 1 Input              |
| 4       | In     | K2          | Key Data 2 Input              |
| 5       | -      | VSS         | GND                           |
| 6       | -      | VDD         | Power Supply                  |
| 7       | Out    | a / KEY-1   | Segment Output / Key Source-1 |
| 8       | Out    | b / KEY-2   | Segment Output / Key Source-2 |
| 9       | Out    | c / KEY-3   | Segment Output / Key Source-3 |
| 10      | Out    | d / KEY-4   | Segment Output/ Key Source-4  |
| 11      | Out    | e           | Segment Output                |
| 12      | In     | f / KEY-6   | Segment Output/ Key Source-6  |
| 13      | In     | g           | Segment Output                |
| 14      | Out    | h           | Segment Output                |
| 15      | -      | VEE         | Pull Down Level               |
| 16      | Out    | i           | Segment Output                |
| 17      | Out    | 7G          | Grid Output                   |
| 18      |        | 6G          |                               |
| 19      |        | 5G          |                               |
| 20      |        | 4G          |                               |
| 21      |        | 3G          |                               |
| 22      |        | 2G          |                               |
| 23      |        | 1G          |                               |
| 24      | -      | VDD         | Power Supply                  |
| 25      | -      | VSS         | GND                           |
| 26      | In     | OSC         | Oscillator Input              |
| 27      | Out    | FP-DOUT     | Serial Data Output            |
| 28      | IN     | FP-DIN      | Serial Data Input             |

# LEAD IDENTIFICATIONS

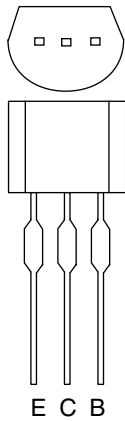

2SA1015-Y(T E2 F T)  
 2SA1015-Y(TPE2)  
 2SC2120-Y(T E2 F T)  
 2SC2120-Y(TPE2)  
 2SC2236-Y-TPE6 C  
 KTA1266(Y)  
 KTA1266-Y-AT/P  
 KTC3203(Y)  
 KTC3203-Y-AT/P  
 KTC3205(Y)  
 KTC3205-Y-AT/P  
 BA1F4M-T  
 KRC103M  
 KRC103M-AT/P  
 KRA103M-AT/P

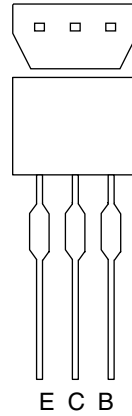

2SC1815-GR(T E2 F T)  
 2SC1815-GR(TPE2)  
 2SC1815-Y(T E2 F T)  
 2SC1815-Y(TPE2)  
 KTA1267(Y)  
 KTA1267Y-AT/P  
 KTC3199(GR, Y)  
 KTC3199-(GR, Y)-AT/P  
 BN1L3Z(P)  
 KRA105M-AT/P  
 KRA110M-AT/P  
 KRA110M

NJM4580M-TE1  
 RC4580IP  
 MM1636XWRE

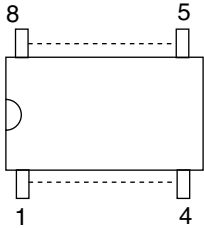

PT6313-S-TP(L)  
 SC16313G

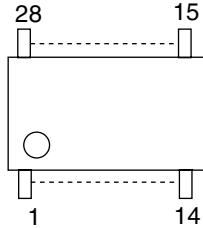

0C-0805T\*002

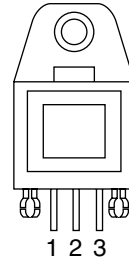

FAN431AZXA  
 KIA431-AT

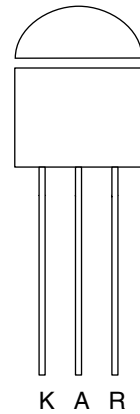

1: R  
 2: A  
 3: K

EL817B  
 EL817C  
 LTV-817B-F  
 LTV-817C-F  
 PS2561A-1(W)

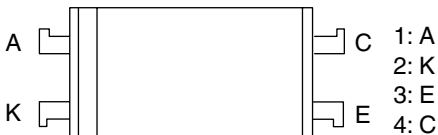

1: A  
 2: K  
 3: E  
 4: C

MM1622XJBEG

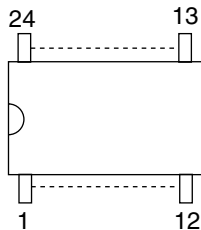

UZ1086-ADJ  
 LD1086V

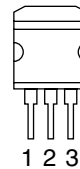

1: GND  
 2: Vout  
 3: Vin

2SD2144S

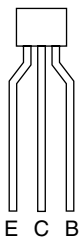

KTD882

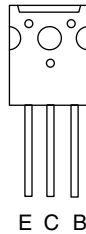

2SK3566

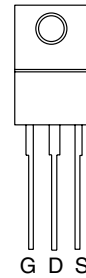

## Note:

A: Anode  
 K: Cathode  
 E: Emitter  
 C: Collector  
 B: Base  
 R: Reference  
 G: Gate  
 D: Drain  
 S: Source



# EXPLODED VIEWS

## Cabinet

See Electrical Parts List for parts with this mark.

Some Ref. Numbers are not in sequence.

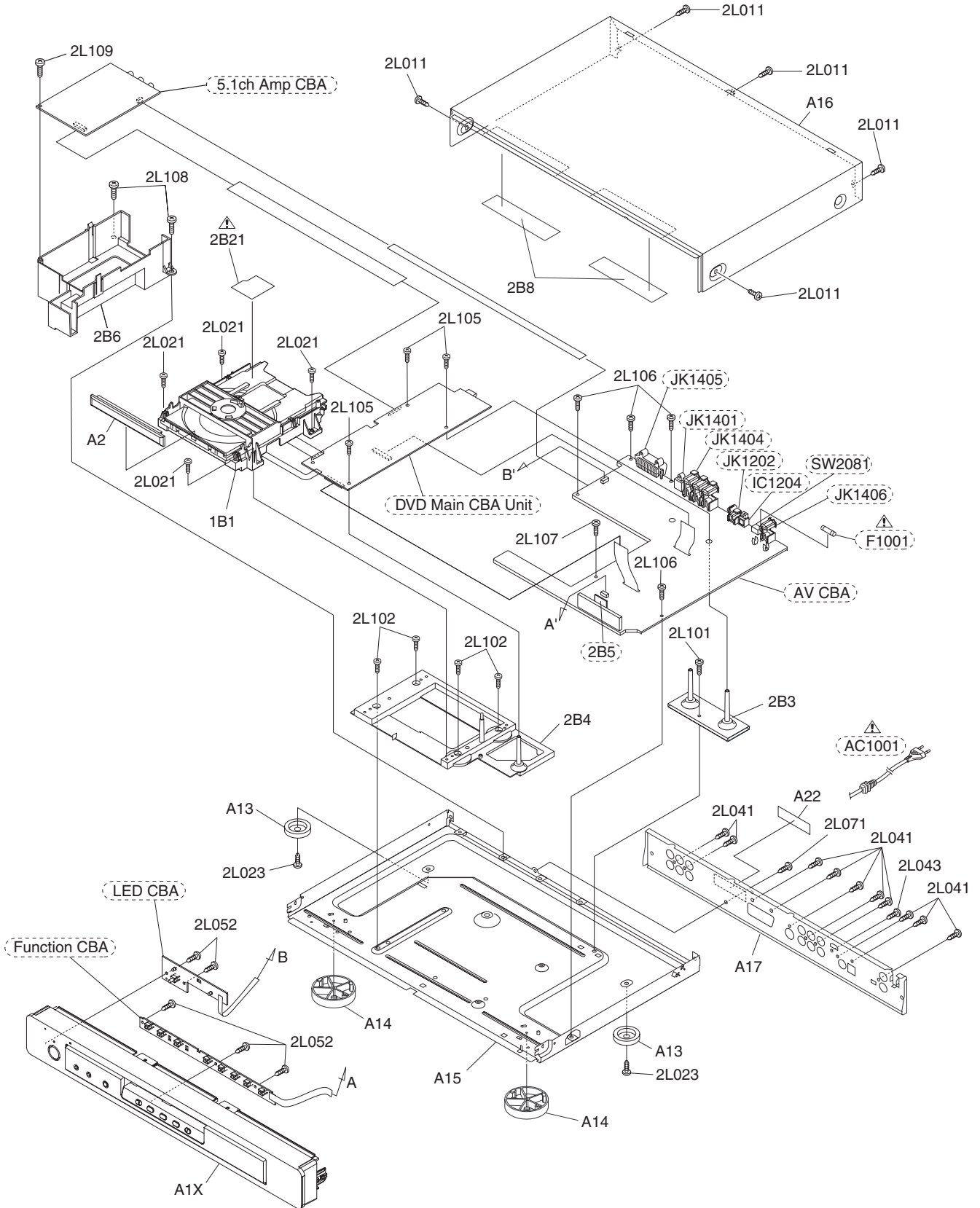

# Packing

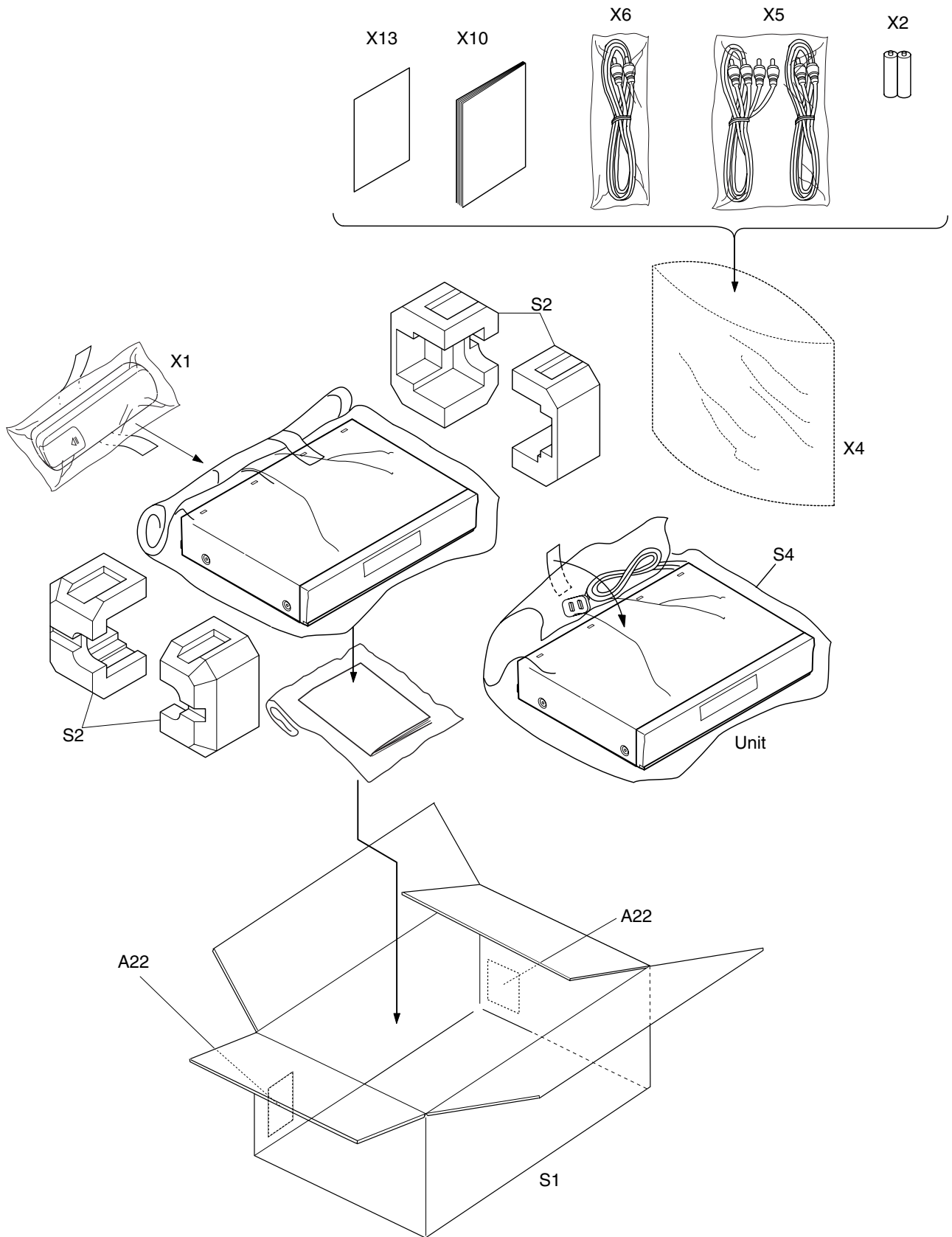



# PARTS LIST

| POS. NO.                        | VERS. COLOR | PART NO. (FOR EUR) | PART NO. (MZ) | PART NAME    | DESCRIPTION   |
|---------------------------------|-------------|--------------------|---------------|--------------|---|
| <b>EXPLODED VIEW PARTS LIST</b> |             |                    |               |              |   |
| A1X                             | /N1B        | 00M38BW248510      | 00M38BW248510 | PANEL        | FRONT PANEL ASSY DV6600 BLACK E61M5UD 1VM220896   |
| A1X                             | /N1S        | 00M38BW248530      | 00M38BW248530 | PANEL        | FRONT PANEL ASSY DV6600 SILVER E61M9ED 1VM220898  |
| A2                              | /N1B        | 00M38BW063010      | 00M38BW063010 | ESCUTCHEON   | TRAY PANEL E61M5UD 1VM422173  |
| A2                              | /N1S        | 00M38BW063210      | 00M38BW063210 | ESCUTCHEON   | TRAY PANEL E61M9ED 1VM422175  |
| A13                             | /N1B        | 00M38BW057020      | 00M38BW057020 | LEG          | LEG ASSY (REAR) BLACK GOLD E61M0UD 1VM421930  |
| A13                             | /N1S        | 00M38BW057220      | 00M38BW057220 | LEG          | LEG ASSY (REAR) SILVER E61M4ED 1VM421931  |
| A14                             | /N1B        | 00M38BW057010      | 00M38BW057010 | LEG          | LEG ASSY (FRONT) BLACK GOLD E61M0UD 1VM421932   |
| A14                             | /N1S        | 00M38BW057210      | 00M38BW057210 | LEG          | LEG ASSY (FRONT) SILVER E61M4ED 1VM421933   |
| A15                             |             | nsp                | nsp           | CHASSIS      | MAIN CHASSIS DV6600 E6180UD 1VM120073   |
| A17                             |             | nsp                | nsp           | PANEL        | REAR PANEL DV6600 FOR N E61M7ED 1VM220886   |
| 1B1                             |             | 00M38BW304010      | 00M38BW304010 | MECHANISM    | MECHA LOADER AND TRAVERSE DVD MECHA E6(FG) N79F1JVM N79F1JVM  |
|                                 |             | 90M-ZZ003000R      | 90M-ZZ003000R | PWB ASSY     | DVD MAIN CBA UNIT N79B3JEP  |
|                                 |             | 90M-ZZ003010R      | 90M-ZZ003010R | PWB ASSY     | AV CBA ASSY / FUNCTION CBA ASSY / LED CBA ASSY 1VSA12274  |
|                                 |             | 90M-ZZ003020R      | 90M-ZZ003020R | PWB ASSY     | 5.1CH AMP CBA 1VSA12393   |
| ▲ AC1001                        |             | 90M-YC000820R      | 90M-YC000820R | MAINS CORD   | ! MAINS CORD PE8B2CG980A-057 WAE0172LW006   |
| <b>PACKING</b>                  |             |                    |               |              |   |
| X1                              |             | 00M38BW0010        | 00M38BW0010   | UNIT KIT     | REMOTE CONTROLLER RC6600DV NA836ED NA836ED  |
| X10                             |             | 00M38BW851310      | 00M38BW851310 | USER GUIDE   | USER GUIDE DV6600/N E61M0UD 1VMN21028   |
| <b>NOT STANDARD SPARE PART</b>  |             |                    |               |              |   |
| S1                              |             | nsp                | 00M38BW801010 | PACKING CASE | PACKING CASE DV6600 E61M5UD 1VM321182   |
| S2                              |             | nsp                | 00M38BW809010 | CUSHION      | CUSHION DV6600 E61M0UD 1VM120092  |
| A16                             | /N1B        | nsp                | 00M38BW257010 | LID          | TOP COVER BLACK E61M0UD 1VM320704   |
| A16                             | /N1S        | nsp                | 00M38BW257210 | LID          | TOP COVER SILVER E61M4ED 1VM320706  |
| X5                              |             | nsp                | 90M-ZD000470R | CORD         | AV CORD TSCA-Y/RW100 WPZ0102TM015<br>OR AV CORD RCA(M*2)TO RCA(M*2) OR WPZ0102LTE01<br>OR AV CORD DC2FN020001 OR WPZ0102CAB01 |
| X6                              |             | nsp                | 90M-ZD000500R | CORD         | RC CORD WPZ0102TM017 (ORANGE) WPZ0102TM017  |
| <b>ELECTRICAL PARTS LIST</b>    |             |                    |               |              |   |
| <b>AV CBA</b>                   |             |                    |               |              |   |
| ▲ C1001                         |             | 90M-DF100360R      | 90M-DF100360R | FILM CAP.    | ! METALIZED FILM CAP. CT2E473DC011<br>0.047UF/250V K OR M OR CT2E473MS037   |
| ▲ C1006                         |             | 90M-DK100850R      | 90M-DK100850R | CER. CAP.    | ! SAFETY CAP. 2200PF/250V CA2E222MR049<br>OR CCN2EMP0E222   |
| CN1601                          |             | nsp                | 90M-YU002020R | FPC          | FFC CABLE 19P AV CBA TO MAIN WX1E6182-001   |
| IC1204                          |             | 90M-YJ002710R      | 90M-YJ002710R | OPT. CONN.   | FIBER OPTIC TRANS. JWHHA00JD002<br>MODULE 0C-0805T*002  |
| ▲ L1001                         |             | 90M-FN000190R      | 90M-FN000190R | FILTER       | ! LINE FILTER 56MH TLF14CB5630R2 LLBG00ZTU022<br>OR 50MH LF-4D-E503(PB FREE) OR LLBG00ZKQ014                                  |
| SW2081                          |             | 90M-SS000760R      | 90M-SS000760R | SW           | SLIDE SWITCH SK12D07VG5-L A SSS0102LY003  |
| ▲ F1001                         |             | 90M-FS001120R      | 90M-FS001120R | FUSE         | ! FUSE T1.6AL/250V PAGC20BW3162<br>OR 50T016H 1.6A/250V OR PAGH20BHV162   |
| JK1202                          |             | 90M-YT003420R      | 90M-YT003420R | TERMINAL     | CINCH JACK(BLACK) MSP-251V-10 JXRL010LY090  |
| JK1401                          |             | 90M-YT003380R      | 90M-YT003380R | TERMINAL     | S TYPE JACK MDC-050V-2.4 LF(B110) JXEL040LY003<br>OR MDC-050V-2.4 OR JXEL040LY001   |
| JK1404                          |             | 90M-YT004560R      | 90M-YT004560R | TERMINAL     | CINCH JACK MSD-246V-120 GILT FE JXRL060LY112  |
| JK1405                          |             | 90M-YT003390R      | 90M-YT003390R | TERMINAL     | 21P RGB JACK AJ-2050*040 JXGL210JD002   |
| JK1406                          |             | 90M-YT004570R      | 90M-YT004570R | TERMINAL     | 2PIN JACK(ORANGE) JXRL020LY109<br>MSD-242V-32 GILT FE   |
| ▲ T1001                         |             | 90M-TS002500R      | 90M-TS002500R | TRANSF.      | ! SWITCHING TRANS 5702 LTT00EPKT167<br>OR BCK-25-069D OR LTT00EPXB022   |

NOTE : \*nsp\* PART IS LISTED FOR REFERENCE ONLY, MARANTZ WILL NOT SUPPLY THESE PARTS.



## NOTE ON SAFETY :

Symbol  Fire or electrical shock hazard. Only original parts should be used to replaced any part marked with symbol . Any other component substitution (other than original type), may increase risk of fire or electrical shock hazard.

| POS. NO. | VERS. COLOR | PART NO. (FOR EUR) | PART NO. (MZ) | PART NAME            | DESCRIPTION                                 |
|----------|-------------|--------------------|---------------|----------------------|---|
|          |             |                    |               | <b>FUNCTION CBA</b>  |   |
| CN2103   |             | 90M-YU002040R      | 90M-YU002040R | FPC                  | FFC CABLE 7P AV CBA TO FNT CBA WX1E61M2-001 |
|          |             |                    |               | <b>LED CBA</b>       |   |
| CN2104   |             | nsp                | 90M-YU002030R | FPC                  | FFC CABLE 7P AV CBA TO IND CBA WX1E61M2-003 |
|          |             |                    |               | <b>5.1CH AMP CBA</b> |   |
| JK7101   |             | 90M-YT004210R      | 90M-YT004210R | TERMINAL             | 6PIN JACK MSD-246V-38 GILT FE JXRL060LY111  |
| W7102    |             | nsp                | 90M-YU002070R | FPC                  | 16P FFC 5.1CH CBA TO MAIN WX1E61E2-002      |

NOTE : "nsp" PART IS LISTED FOR REFERENCE ONLY, MARANTZ WILL NOT SUPPLY THESE PARTS.

**NOTE ON SAFETY :**

Symbol  Fire or electrical shock hazard. Only original parts should be used to replaced any part marked with symbol . Any other component substitution (other than original type), may increase risk of fire or electrical shock hazard.