

# Service Manual

DV8300 /C1G/F1N/L1G/N1G/S1G  
/A1B/N1B/U1B

SACD/DVD Player

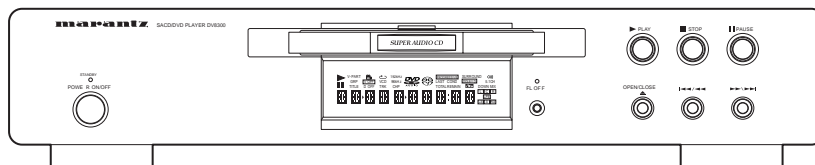

## TABLE OF CONTENTS

SECTION	PAGE
1. TECHNICAL SPECIFICATIONS .....	1
2. CONNECTION FACILITIES .....	2
3. INFORMATIONS .....	3
4. SERVICE HINTS AND TOOLS.....	4
5. WARNING AND LASER SAFETY INSTRUCTIONS .....	5
6. TAKING THE DISC OUT OF EMERGENCY .....	7
7. SERVICE MODE AND TROUBLE SHOOTING .....	8
8. WIRING DIAGRAMS .....	11
9. BLOCK DIAGRAMS .....	13
10. SCHEMATIC DIAGRAM.....	15
11. PARTS LOCATION.....	35
12. MICROPROCESSOR AND IC DATA.....	40
13. EXPLODED VIEW AND PARTS LIST .....	57
14. ELECTRICAL PARTS LIST .....	60
DB-VLD302 (DVD LOADER FOR MARANTZ)	
2.1 LOADING MECHANISM ASS'Y AND LOAB PCB ASS'Y .....	2-2
2.2 TRAVERSE MECHANISM ASS'Y.....	2-5
DB-VPB305 (DVD PCB MODULE FOR MARANTZ)	
3.1 DIAGRAMS (BLOCK, WIRING, SCHEMATIC, WAVEFORMS) .....	3-2
3.2 PCB CONNECTION DIAGRAM.....	3-15
3.3 GENERAL INFOMATION (ID NUMBER., DISASSEMBLY., IC DATA).....	3-18
3.4 PCB PARTS LIST.....	3-45

Please use this service manual with referring to the user guide ( D.F.U. ) without fail.  
修理の際は、必ず取扱説明書を準備し操作方法を確認の上作業を行ってください。

# marantz®

## DV8300

## MARANTZ DESIGN AND SERVICE

Using superior design and selected high grade components, **MARANTZ** company has created the ultimate in stereo sound. Only original **MARANTZ** parts can insure that your **MARANTZ** product will continue to perform to the specifications for which it is famous.

Parts for your **MARANTZ** equipment are generally available to our National Marantz Subsidiary or Agent.

### ORDERING PARTS :

Parts can be ordered either by mail or by Fax.. In both cases, the correct part number has to be specified.

The following information must be supplied to eliminate delays in processing your order :

1. Complete address
2. Complete part numbers and quantities required
3. Description of parts
4. Model number for which part is required
5. Way of shipment
6. Signature : any order form or Fax. must be signed, otherwise such part order will be considered as null and void.

#### USA

**MARANTZ AMERICA, INC**  
1100 MAPLEWOOD DRIVE  
ITASCA, IL. 60143  
USA  
PHONE : 630 - 741 - 0300  
FAX : 630 - 741 - 0301

#### EUROPE / TRADING

**MARANTZ EUROPE B.V.**  
P. O. BOX 8744, BUILDING SILVERPOINT  
BEEMDSTRAAT 11, 5653 MA EINDHOVEN  
THE NETHERLANDS  
PHONE : +31 - 40 - 2507844  
FAX : +31 - 40 - 2507860

#### CANADA

**LENBROOK INDUSTRIES LIMITED**  
633 GRANITE COURT,  
PICKERING, ONTARIO L1W 3K1  
CANADA  
PHONE : 905 - 831 - 6333  
FAX : 905 - 831 - 6936

#### PROFESSIONAL AMERICAS

**SUPERSCOPE TECHNOLOGIES, INC.**  
MARANTZ PROFESSIONAL PRODUCTS  
2640 WHITE OAK CIRCLE, SUITE A  
AURORA, ILLINOIS 60504 USA  
PHONE : 630 - 820 - 4800  
FAX : 630 - 820 - 8103

#### PROFESSIONAL AUSTRALIA

**TECHNICAL AUDIO GROUP PTY, LTD**  
558 DARLING STREET,  
BALMAIN, NSW 2041,  
AUSTRALIA  
PHONE : 61 - 2 - 9810 - 5300  
FAX : 61 - 2 - 9810 - 5355

#### PROFESSIONAL HONG KONG

**Jolly ProAudio Broadcast Engineering Ltd.**  
UNIT 2, 10F, WAH HUNG CENTRE,  
41 HUNG TO ROAD, KWUN TONG, KLN.,  
HONG KONG  
PHONE : 852 - 21913660  
FAX : 852 - 21913990

#### AUSTRALIA

**QualiFi Pty Ltd,**  
24 LIONEL ROAD,  
MT. WAVERLEY VIC 3149  
AUSTRALIA  
PHONE : +61 - (0)3 - 9543 - 1522  
FAX : +61 - (0)3 - 9543 - 3677

#### THAILAND

**MRZ STANDARD CO., LTD**  
746 - 754 MAHACHAI ROAD.,  
WANGBURAPAPIROM, PHRANAKORN,  
BANGKOK, 10200 THAILAND  
PHONE : +66 - 2 - 222 9181  
FAX : +66 - 2 - 224 6795

#### SINGAPORE

**WO KEE HONG DISTRIBUTION PTE LTD**  
130 JOO SENG ROAD  
#03-02 OLIVINE BUILDING  
SINGAPORE 368357  
PHONE : +65 6858 5535 / +65 6381 8621  
FAX : +65 6858 6078

#### NEW ZEALAND

**WILDASH AUDIO SYSTEMS NZ**  
14 MALVERN ROAD MT ALBERT  
AUCKLAND NEW ZEALAND  
PHONE : +64 - 9 - 8451958  
FAX : +64 - 9 - 8463554

#### TAIWAN

**PAI- YUING CO., LTD.**  
6 TH FL NO, 148 SUNG KIANG ROAD,  
TAIPEI, 10429, TAIWAN R.O.C.  
PHONE : +886 - 2 - 25221304  
FAX : +886 - 2 - 25630415

#### MALAYSIA

**WO KEE HONG ELECTRONICS SDN. BHD.**  
SUITE 8.1, LEVEL 8, MENARA GENESIS,  
NO. 33, JALAN SULTAN ISMAIL,  
50250 KUALA LUMPUR, MALAYSIA  
PHONE : +60 3 - 21457677  
FAX : +60 3 - 21458180

#### JAPAN Technical

**MARANTZ JAPAN, INC.**  
35- 1, 7- CHOME, SAGAMIONO  
SAGAMIHARA - SHI, KANAGAWA  
JAPAN 228-8505  
PHONE : +81 42 748 1013  
FAX : +81 42 741 9190

#### 日本マランツ株式会社

本社 〒228-8505  
神奈川県相模原市相模大野7-35-1  
営業本部 〒150-0022  
東京都渋谷区恵比寿南1-11-9

#### KOREA

**MK ENTERPRISES LTD.**  
ROOM 604/605, ELECTRO-OFFICETEL, 16-58,  
3GA, HANGANG-RO, YONGSAN-KU, SEOUL  
KOREA  
PHONE : +822 - 3232 - 155  
FAX : +822 - 3232 - 154

### SHOCK, FIRE HAZARD SERVICE TEST :

**CAUTION :** After servicing this appliance and prior to returning to customer, measure the resistance between either primary AC cord connector pins ( with unit NOT connected to AC mains and its Power switch ON ), and the face or Front Panel of product and controls and chassis bottom.

Any resistance measurement less than 1 Megohms should cause unit to be repaired or corrected before AC power is applied, and verified before it is return to the user/customer.

Ref. UL Standard No. 1492.

In case of difficulties, do not hesitate to contact the Technical Department at above mentioned address.

# 1. TECHNICAL SPECIFICATIONS

## General

System..... DVD-Video, DVD-Audio, DVD-R/RW,  
Video-CD, SACD, CD and MP3 files

### Power requirements

A Version ..... AC 240 V, 50 Hz  
C Version ..... AC 220 V, 60 Hz  
F Version..... AC 100 V, 50 / 60 Hz  
K Version ..... AC 220 V, 50 Hz  
L Version..... AC 110 V, 60 Hz  
N Version ..... AC 230 V, 50 Hz  
S Version ..... AC 230 V, 50 / 60 Hz  
U Version ..... AC 120 V, 60 Hz

### Power consumption

F Version..... 18 W  
L Version..... 19 W  
Other Version..... 20 W

### Weight

N Version ..... 6.2 kg (13 lb 44 oz)  
Other Version..... 6.1 kg (13 lb 44 oz)

Dimensions..... 440 (W) x 307 (D) x 89 (H) mm  
(17 8/25 (W) x 12 2/25 (D) x 3 1/2 (H) in.)  
(Not including protruding cables, etc.)

Operating temperature ..... +5 °C to +35 °C (+41 °F to +96 °F)

Operating humidity ..... 5% to 85% (no condensation)

## S-Video output

Y (luminance) - Output level ..... 1 Vp-p (75 Ω)

C (color) - Output level : NTSC ..... 286 mVp-p (75 Ω)  
: PAL ..... 300 mVp-p (75 Ω)

Jacks ..... S-VIDEO jack

## Video output (2 individual outputs)

Output level..... 1 Vp-p (75 Ω)

Jacks ..... RCA jack

## Component video output (Y, C<sub>B</sub>/P<sub>B</sub>, C<sub>R</sub>/P<sub>B</sub>)

Output level..... Y : 1.0 Vp-p (75 Ω)

C<sub>B</sub>/P<sub>B</sub>, C<sub>R</sub>/P<sub>B</sub>: 0.7 Vp-p (75 Ω)

Jacks ..... RCA jack

## R / G / B output

Output level..... R / G / B : 0.7 Vp-p (75 Ω)

Jacks (N Version)..... 21 pin SCART connector

## D1/D2 video output (except for N, U Version)

Output level..... Y : 1.0 Vp-p (75 Ω)

C<sub>B</sub>/P<sub>B</sub>, C<sub>R</sub>/P<sub>B</sub>: 0.7 Vp-p (75 Ω)

Jacks ..... D terminal

## Audio output (2 individual outputs)

Output level

During audio output ..... 200 mVrms (1 kHz, -20 dB)

Number of channels ..... 2

Jacks ..... RCA jack

## Audio output (multi-channel / L, R, C, SW, LS, RS)

Output level

During audio output ..... 200 mVrms (1 kHz, -20 dB)

Number of channels ..... 6

Jacks ..... RCA jack

## Digital audio characteristics

Frequency response ..... 4 Hz to 44 kHz (DVD fs: 96 kHz)

4 Hz to 88 kHz (DVD-Audio fs: 192 kHz)

S/N ratio..... more than 118 dB

Dynamic range ..... more than 108 dB

Total harmonic distortion ..... 0.001%

Wow and flutter..... Limit of measurement(-0.001% W. PEAK)  
or lower

## Digital output

Optical digital output ..... Optical digital jack

Coaxial digital output ..... RCA jack

## Accessories

Audio/Video cord ..... 1

System Control cord ..... 1

Power Cord ..... 1

Remote control unit ..... 1

AA (R6P) dry cell batteries ..... 2

Operating Instructions ..... 1

## Note

The specifications and design of this product are subject to change without notice, due to improvement.

## 2. CONNECTION FACILITIES

### 2.1 Video performance (/N only)

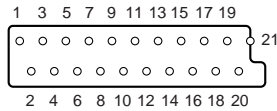

#### 2.1.1 SCART

##### Pin No. TV (OUT)

Pin 1	Audio R out : 2Vrms
Pin 2	Audio R in : 2Vrms
Pin 3	Audio L out : 2Vrms
Pin 4	GND
Pin 5	GND
Pin 6	Audio L in : 2Vrms
Pin 7	Blue out/C in Blue : 0.7Vpp ±0.1V into 75 Ohm *1 C : 300mVpp ±30 into 75 Ohm *2
Pin 8	function switching out <2V : TV >5/<8 : asp.ratio 16 : 9 DVD/AUX >9.5/<12 : asp.ratio 4 : 3 DVD/AUX
Pin 9	GND
Pin 10	not connected
Pin 11	Green out:0.7Vpp ±0.1V into 75 Ohm *1
Pin 12	not connected
Pin 13	GND
Pin 14	GND
Pin 15	Red/C out Red : 0.7Vpp ±0.1V into 75 Ohm *1 C : 300mVpp ±30 into 75 Ohm *2
Pin 16	fast switching out <0.4V into 75 Ohm=CVBS/S-Video 1</>3 into 75 Ohm=RGB
Pin 17	GND
Pin 18	GND
Pin 19	CVBS/Y out : 1Vpp ±0.1V *1
Pin 20	CVBS/Y in : 1Vpp ±0.1V *1
Pin 21	GND

##### Pin No. AUX (IN)

Pin 1	Audio R out : 2Vrms
Pin 2	Audio R in : 2Vrms
Pin 3	Audio L out : 2Vrms
Pin 4	GND
Pin 5	GND
Pin 6	Audio L in : 2Vrms
Pin 7	Blue in/C out Blue : 0.7Vpp ±0.1V into 75 Ohm *1 C : 300mVpp ±30 into 75 Ohm *2
Pin 8	function switching in<2V : DVD >5/<8 : asp.ratio 16 : 9 AUX >9.5/<12 : asp.ratio 4 : 3 AUX
Pin 9	GND
Pin 10	not connected
Pin 11	Green in:0.7Vpp ±0.1V into 75 Ohm
Pin 12	not connected
Pin 13	GND
Pin 14	GND
Pin 15	Red/C in Red : 0.7Vpp ±0.1V into 75 Ohm *1 C : 300mVpp ±30 into 75 Ohm *2
Pin 16	fast switching in <0.4V into 75 Ohm=CVBS/S-Video 1</>3 into 75 Ohm=RGB
Pin 17	GND
Pin 18	GND
Pin 19	CVBS/Y out : 1Vpp ±0.1V *1
Pin 20	CVBS/Y in : 1Vpp ±0.1V *1
Pin 21	GND

\*1 : 100% White    \*2 : Burst Level    \*3 : color bar(chroma level : 75%)

#### What are "regional codes"?

Motion picture studios want to control the home release of movies in different countries because theater releases aren't simultaneous (a movie may come out on DVD in the US when it's just hitting screens in Europe). Therefore they have required that the DVD standard include codes which can be used to lock out the playback of certain discs in certain geographical regions. Players sold in each region will have that region's code built into the player. The player will refuse to play these "region coded" discs which are not allowed in the region. However, regional codes are entirely optional. Discs without codes will play on any player in any country. Some studios have already announced that only their new releases will have regional codes. There are six regions:

- |                                    |                              |
|------------------------------------|------------------------------|
| 1. United States and Canada        | 2. Europe and Japan          |
| 3. Far East (except Japan & China) | 4. South America and Oceania |
| 5. Africa and the Middle East      | 6. China (except Hong Kong)  |

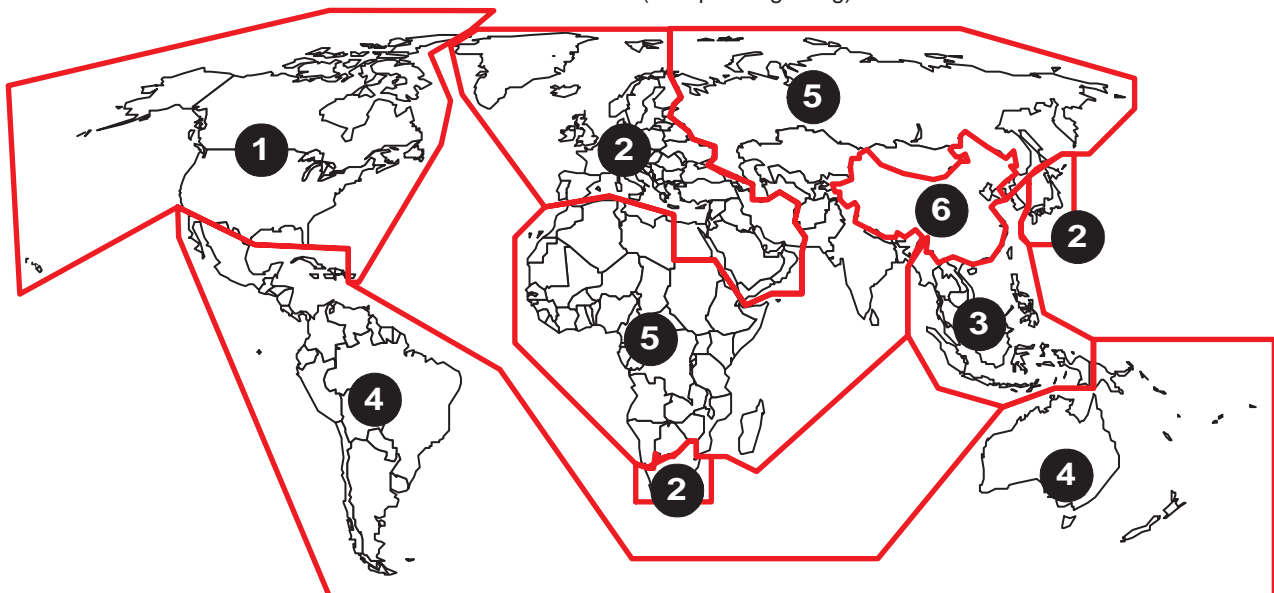

Map of DVD Regions

### 3. INFORMATIONS

#### REGION CODE

VERSION	REGION CODE	COUNTRY
/UXX	1	USA/CANADA
/FXX	2	JAPAN
/NXX	2	EUROPE
/CXX	3	KOREA
/LXX	3	TAIWAN
/SXX	3	SINGAPORE/HONGKONG
/AXX	4	AUSTRALIA
/KXX	6	CHINA

#### DVD INFORMATION

Below is a glossary of the new terms related to DVD.

##### Title:

A disc may have more than one story/movie on it, so each story/movie is called a "title".

For example, if there are 2 movies on the disc, they are separated into Title 1 and Title 2.

##### Chapter:

A title may also be separated into chapters.

For example, a movie (title) may be separated into 3 scenes (chapters).

Title 1			Title 2		
Chapter 1	Chapter 2	Chapter 3	Chapter 1	Chapter 2	Chapter 3

##### Subtitles:

DVDs are recorded with up to 32 different subtitle languages. If a disc has more than one subtitle language, you can select the subtitle language that you want to read.

##### Soundtrack language:

DVDs are recorded with up to 8 different soundtrack languages. If a disc has more than one language, you can select the soundtrack language that you want to listen to.

##### Multi-angles:

On some DVDs, scenes have been filmed from different angles (up to a maximum of 9). On these discs, you can select the angle that you want to watch. Please refer to the DVD's manual to see which scenes have multi-angles.











##### Resetting the Player to System Settings:

To reset the player, press and hold [STOP] button on the front panel when pressing Power switch to turn the power on.

All program memory, saved settings from functions such as Last Memory and Condition Memory are cleared, and all Setup screen menus are returned to factory settings.

### THE DISCS THAT THE DV8300 CAN HANDLE

The following discs can be played back with a DV-12S1

Types of playable discs and their marks	Diameter/ Playable sides	Playback time	
DVD-Audio <i>DVD-Video</i>    	DVD-Audio <i>DVD-Video</i>	Digital audio Digital video (MPEG 2)	
	12 cm (5in.)/ single-sided	1 layer 2 layer	133 min. 242 min.
	12 cm (5in.)/ double-sided	1 layer 2 layer	266 min. 484 min.
	DVD-Audio <i>DVD-Video</i>	8 cm (3 in.)/ single-sided  8 cm (3 in.)/ double-sided	Digital audio Digital video (MPEG 2)  41 min. 75 min.  82 min. 150 min.
DVD-RW (JAPAN & USA model only)  	DVD-RW  12 cm (5in.)/ single-sided  8 cm (3 in.)/ single-sided	Digital audio Digital video (MPEG 2)  Max. 360 min.  Max. 100 min.	
VIDEO CD  	VIDEO CD  12 cm (5 in.)/ single-sided	Digital audio Digital video (MPEG 1) Max. 74 minutes	
	VIDEO CD single  8 cm (3 in.)/ single-sided	Digital audio Digital video (MPEG 1) Max. 20 minutes	
CD     **   **	CD  12 cm (5 in.)/ single-sided  	Digital audio  Max. 74 minutes	
	CD single  8 cm (3 in.)/ single-sided  	Digital audio  Max. 20 minutes	
	F-Disc  	(F only) (株) フジカラーサービスの フジレシネサービスで作成された ディスクです。	

**Note:**The regional code of the discs must meet to the regional code of the DV8300

The disc format logos shown above are found on disc labels or on disc jackets.

- To prevent malfunction, do not use an 8 cm (3 in.) adaptor (for CDs).
- Discs other than the ones indicated above cannot be played on this unit.
- DVDs that have incompatible region numbers, DVDROM, DVD-RAM, and CD-ROM cannot be played on this unit. The region number of the player can be found on the rear panel.

##### \* Playing DVD-RW discs (JAPAN & USA model only)

- You may not be able to play non-finalized DVD-RW discs.
- Copyrighted content originally provided with the permission of one generation and recorded on DVD discs cannot be played on this player.
- When playing a DVD-RW disc that was edited on a DVD recorder, you may see scenes from just before the edited point. This is not a malfunction.
- Up to 20 characters of a title name can be displayed.

##### \*\* Playing recordable CDs

- Note that this unit cannot record onto recordable discs.
- This unit can play music-use CD-R and CD-RW discs.

However, depending on the condition of the CD-Recorder and the disc, you may find that not all discs will play successfully. (For example, if the disc is scratched or dirty, or if the player fs pickup lens is dirty.)

## 4. SERVICE HINTS AND TOOLS

### SERVICE HINTS

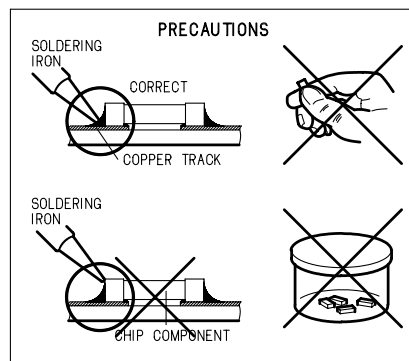
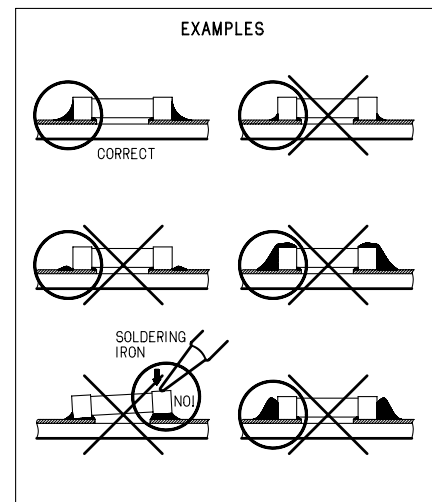
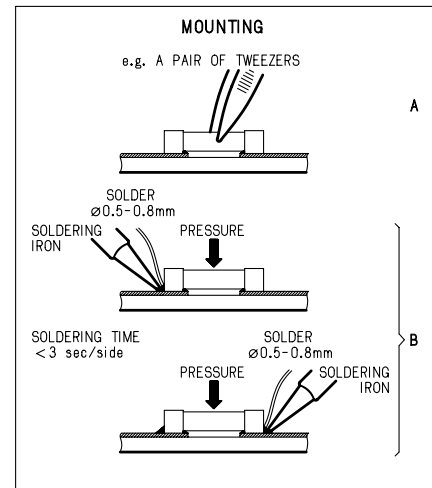
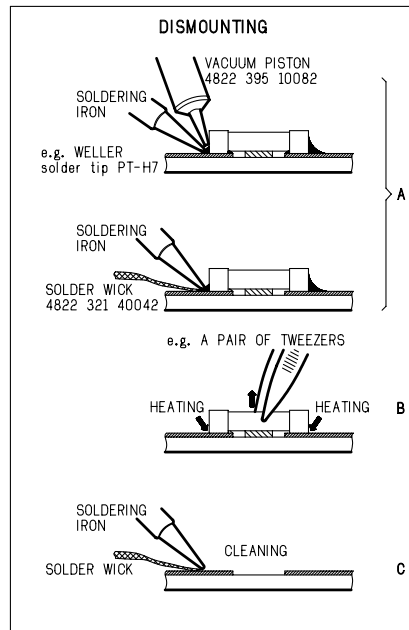
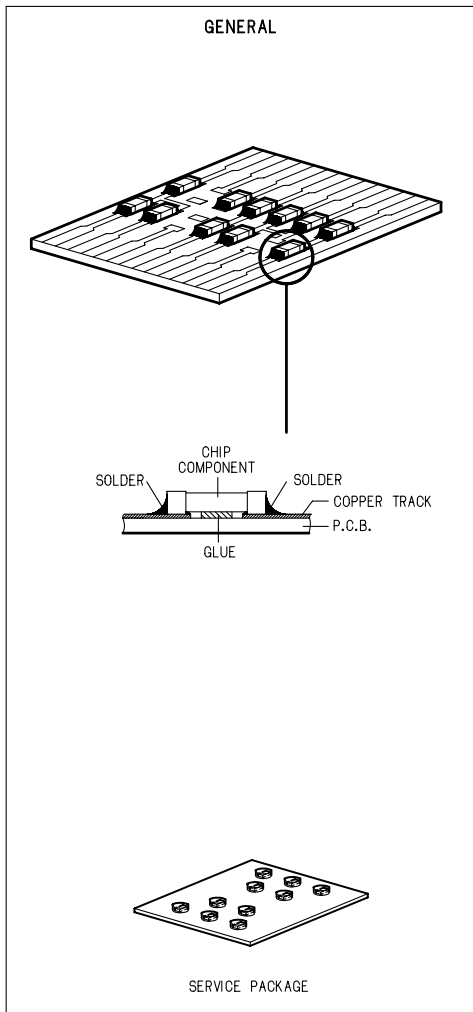

### SERVICE TOOLS

Audio signals disc	4822 397 30184
Disc without errors (SBC444)+	
Disc with DO errors, black spots and fingerprints (SBC444A)	4822 397 30245
Disc (65 min 1kHz) without no pause	4822 397 30155
Max. diameter disc (58.0 mm)	4822 397 60141
Torx screwdrivers	
Set (straight)	4822 395 50145
Set (square)	4822 395 50132
13th order filter	4822 395 30204
DVD test disc (PAL)	4822 397 10131
DVD test disc (NTSC) ALMEDIO	TDV-540

## 5. WARNING AND LASER SAFETY INSTRUCTIONS

### **GB** WARNING

All ICs and many other semi-conductors are susceptible to electrostatic discharges (ESD). Careless handling during repair can reduce life drastically.

When repairing, make sure that you are connected with the same potential as the mass of the set via a wrist wrap with resistance.

Keep components and tools also at this potential.

ESD



### **NL** WAARSCHUWING

Alle IC's en vele andere halfgeleiders zijn gevoelig voor elektrostatische ontladingen (ESD).

Onzorgvuldig behandelen tijdens reparatie kan de levensduur drastisch doen verminderen.

Zorg ervoor dat u tijdens reparatie via een polsband met weerstand verbonden bent met hetzelfde potentiaal als de massa van het apparaat.

Houd componenten en hulpmiddelen ook op hetzelfde potentiaal.

### **F** ATTENTION

Tous les IC et beaucoup d'autres semi-conducteurs sont sensibles aux décharges statiques (ESD).

Leur longévité pourrait être considérablement écourtée par le fait qu'aucune précaution n'est prise à leur manipulation.

Lors de réparations, s'assurer de bien être relié au même potentiel que la masse de l'appareil et enfiler le bracelet serti d'une résistance de sécurité.

Veiller à ce que les composants ainsi que les outils que l'on utilise soient également à ce potentiel.

### **D** WARNUNG

Alle IC und viele andere Halbleiter sind empfindlich gegen elektrostatische Entladungen (ESD).

Unvorsichtige Behandlung bei der Reparatur kann die Lebensdauer drastisch vermindern.

Sorgen sie dafür, das Sie im Reparaturfall über ein Pulsarmband mit Widerstand mit dem Massepotential des Gerätes verbunden sind.

Halten Sie Bauteile und Hilfsmittel ebenfalls auf diesem Potential.

### **I** AVVERTIMENTO

Tutti IC e parecchi semi-conduttori sono sensibili alle scariche statiche (ESD).

La loro longevità potrebbe essere fortemente ridatta in caso di non osservazione della più grande cauzione alla loro manipolazione.

Durante le riparazioni occorre quindi essere collegato allo stesso potenziale che quello della massa dell'apparecchio tramite un braccialetto a resistenza.

Assicurarsi che i componenti e anche gli utensili con quali si lavora siano anche a questo potenziale.

### **GB**

Safety regulations require that the set be restored to its original condition and that parts which are identical with those specified be used.

### **NL**

Veiligheidsbepalingen vereisen, dat het apparaat in zijn oorspronkelijke toestand wordt terug gebracht en dat onderdelen, identiek aan de gespecificeerde worden toegepast.

### **D**

Bei jeder Reparatur sind die geltenden Sicherheitsvorschriften zu beachten. Der Originalzustand des Gerats darf nicht verändert werden. Für Reparaturen sind Original-Ersatzteile zu verwenden.

### **I**

Le norme di sicurezza esigono che l'apparecchio venga rimesso nelle condizioni originali e che siano utilizzati pezzi di ricambio identici a quelli specificati.

### **F**

Les normes de sécurité exigent que l'appareil soit remis à l'état d'origine et que soient utilisées les pièces de rechange identiques à celles spécifiées.



## SHOCK, FIRE HAZARD SERVICE TEST:

**CAUTION:** After servicing this appliance and prior to returning to customer, measure the resistance between either primary AC cord connector pins (with unit NOT connected to AC mains and its Power switch ON), and the face or Front Panel of product and controls and chassis bottom,

Any resistance measurement less than 1 Megohms should cause unit to be repaired or corrected before AC power is applied, and verified before return to user/customer.

Ref.UL Standard NO.1492.

## NOTE ON SAFETY:

Symbol  : Fire or electrical shock hazard. Only original parts should be used to replace any part with symbol . Any other component substitution (other than original type), may increase risk of fire or electrical shock hazard.

"Pour votre sécurité, ces documents doivent être utilisés par des spécialistes agréés, seuls habilités à réparer votre appareil en panne."

## LASER SAFETY

This unit employs a laser. Only a qualified service person should remove the cover or attempt to service this device, due to possible eye injury.

### LASER DEVICE UNIT

Type: SemiconductorlaserGaAlAs  
Wave length: 650 nm (DVD)  
780 nm (VCD/CD)  
Output Power: 7 mW (DVD)  
10 mW (VCD/CD)  
Beam divergence: 60 degree



**USE OF CONTROLS OR ADJUSTMENTS OR PERFORMANCE OF PROCEDURE OTHER THAN THOSE SPECIFIED HEREIN MAY RESULT IN HAZARDOUS RADIATION EXPOSURE.**

**AVOID DIRECT EXPOSURE TO BEAM**

### WARNING

The use of optical instruments with this product will increase eye hazard.  
Repair handling should take place as much as possible with a disc loaded inside the player

### WARNING LOCATION: INSIDE ON LASER COVERSIELD

CAUTION VISIBLE AND INVISIBLE LASER RADIATION WHEN OPEN AVOID EXPOSURE TO BEAM  
ADVARSEL SYNLIG OG USYNLIG LASERSTRÅLING VED ÅBNING UNDGÅ UDSÆTTELSE FOR STRÅLING  
ADVARSEL SYNLIG OG USYNLIG LASERSTRÅLING NÅR DEKSEL ÅPNES UNNGÅ EKSPONERING FOR STRÅLEN  
WARNING SYNLIG OCH OSYNLIG LASERSTRÅLNING NÅR DENNA DEL ÅR ÖPPNAD BETRAKTA EJ STRÅLEN  
VARO! AVATT AESSA OLET ALTTIINA NÄKYVÄLLE JA NÄKYMÄTTÖMÄLLE LASER SÄTEILYLLE. ÄLÄ KATSO SÄTEESEEN  
VORSICHT SICHTBARE UND UNSICHTBARE LASERSTRAHLUNG WENN ABDECKUNG GEÖFFNET NICHT DEM STRAHL AUSSETZEN  
DANGER VISIBLE AND INVISIBLE LASER RADIATION WHEN OPEN AVOID DIRECT EXPOSURE TO BEAM  
ATTENTION RAYONNEMENT LASER VISIBLE ET INVISIBLE EN CAS D'OUVERTURE EXPOSITION DANGEREUSE AU FAISCEAU



### 6. TAKING THE DISC OUT OF EMERGENCY

- 1. Remove 6 screws on the top cover and remove the top cover.
- 2. Put a finger is under the mechanism and Turn the gear to the direction with your finger.
- 3. The disc tray will opened.

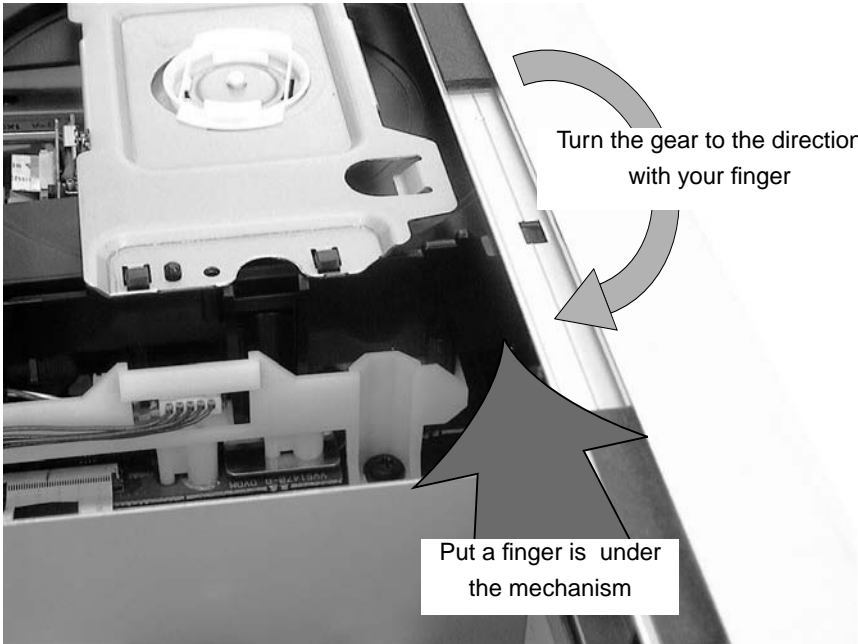
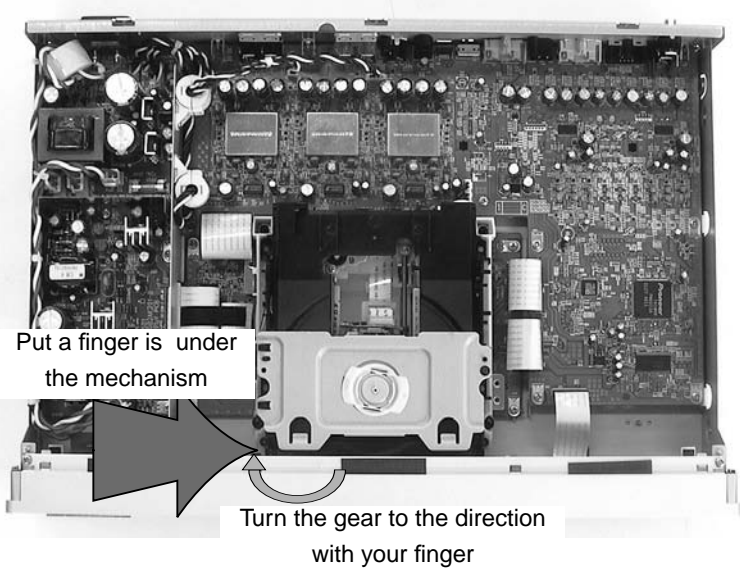
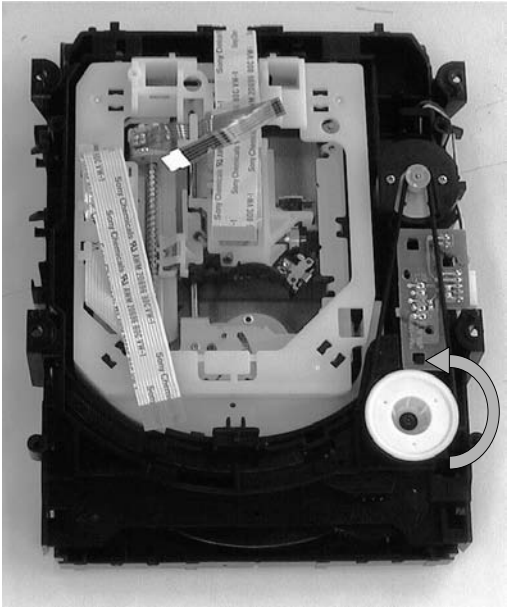

## 7. SERVICE MODE AND TROUBLE SHOOTING

### SERVICE MODE

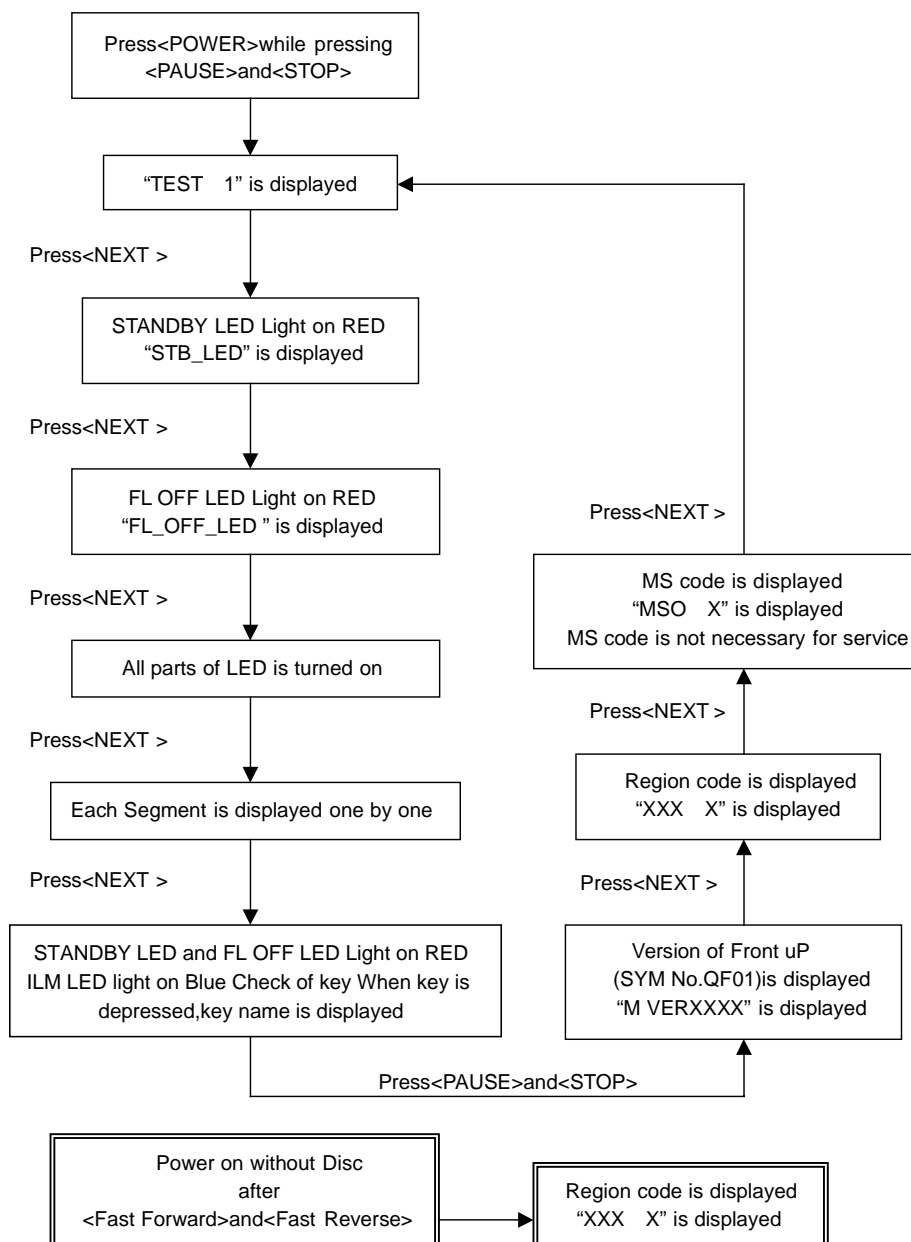

### ERROR CODE

Error codes are displayed on the FL display.

FL Display	Possible causes	Operation of the unit
AV1 VER	AV-1 chip is not a match with program of system controller.	The sound may not out with the specific audio.
CPU AERR	CPU address error. (Hardware is unusual.)	No operation.
DMA AERR	DMA address error. (Hardware is unusual.)	No operation.
FLASH ID	Difference in versions of the internal ROM of the system controller and of the flash ROM, or bus line failure or reverse installation.	No operation.
FLASH WRP	Write protect error of the flash ROM.	No operation.
FLASH SIG	Difference in part number of the flash ROM. (When the ROM which couldn't be used was used.)	No operation.
FLASH SUM	Check sum error of the flash ROM (It exceeds the regular size.) or reverse installation. (Hardware is unusual.)	No operation.
FLASH SIZE	Size error of the flash ROM. (Use 4 or 8 M-bit.)	No operation.
ILLGAL	The system controller fetched a code other than an operation code. (Hardware is unusual.)	No operation.
RESERVE	Undefined interrupt. (Hardware is unusual.)	No operation.
SLOT	Inappropriate slot command issued. (Hardware is unusual.)	No operation.

- To Confirm version of System uP. on DVDM.

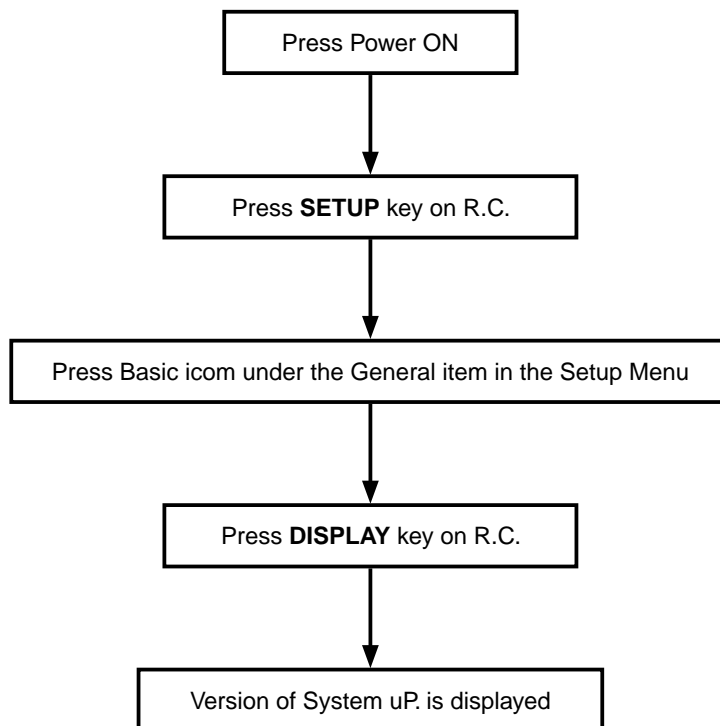

"**Region : X / Ver : XXXX(XX) / AV1 : x.x / x.x**" is displayed

The version displayed here is a version written in the system microprocessor of DVDM (002A).  
Change of this version by external operation cannot be performed.

## TROUBLE SHOOTING

- No Power ON
- FL is not turned ON
- FL indication is unusual

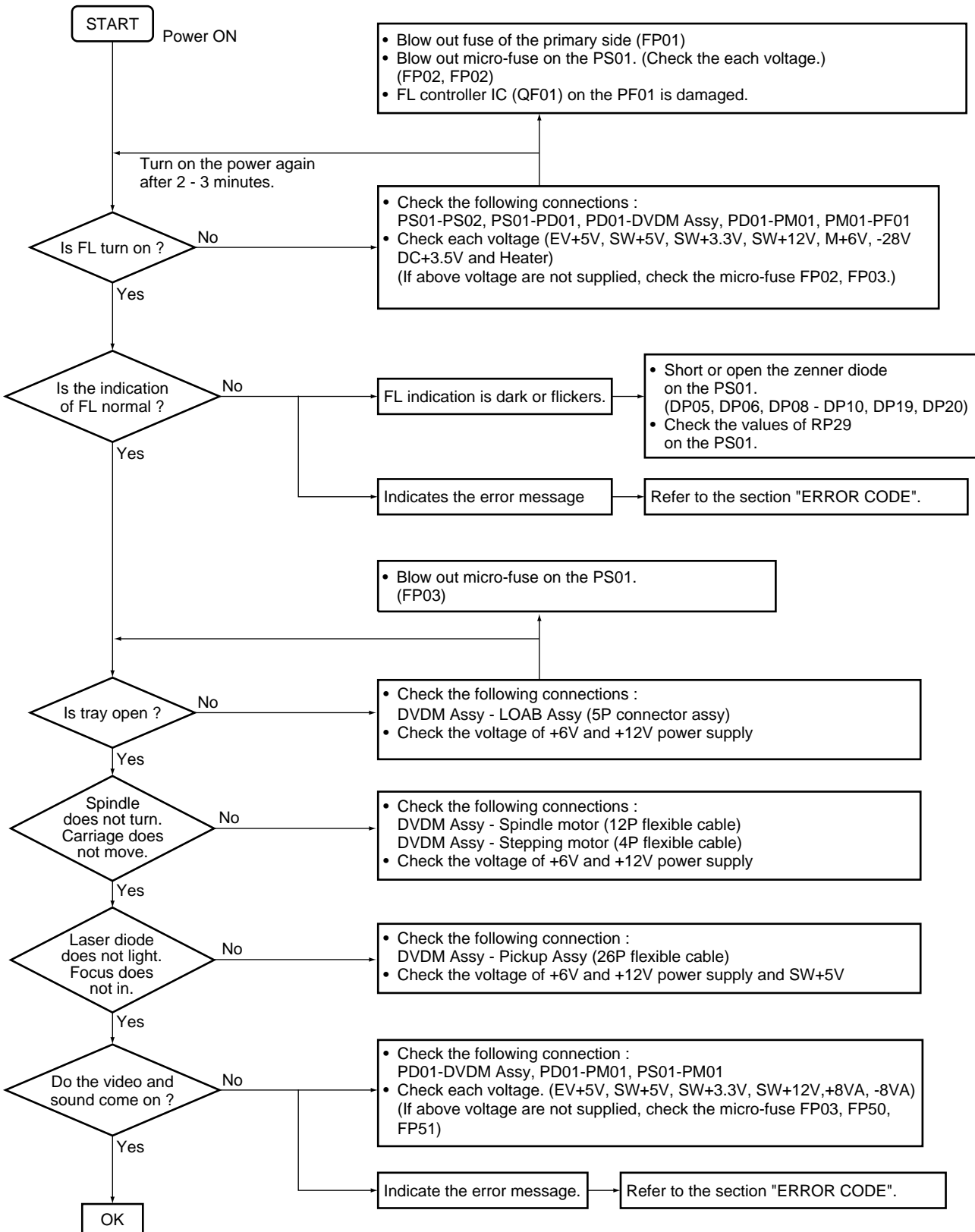

# 8. WIRING DIAGRAM

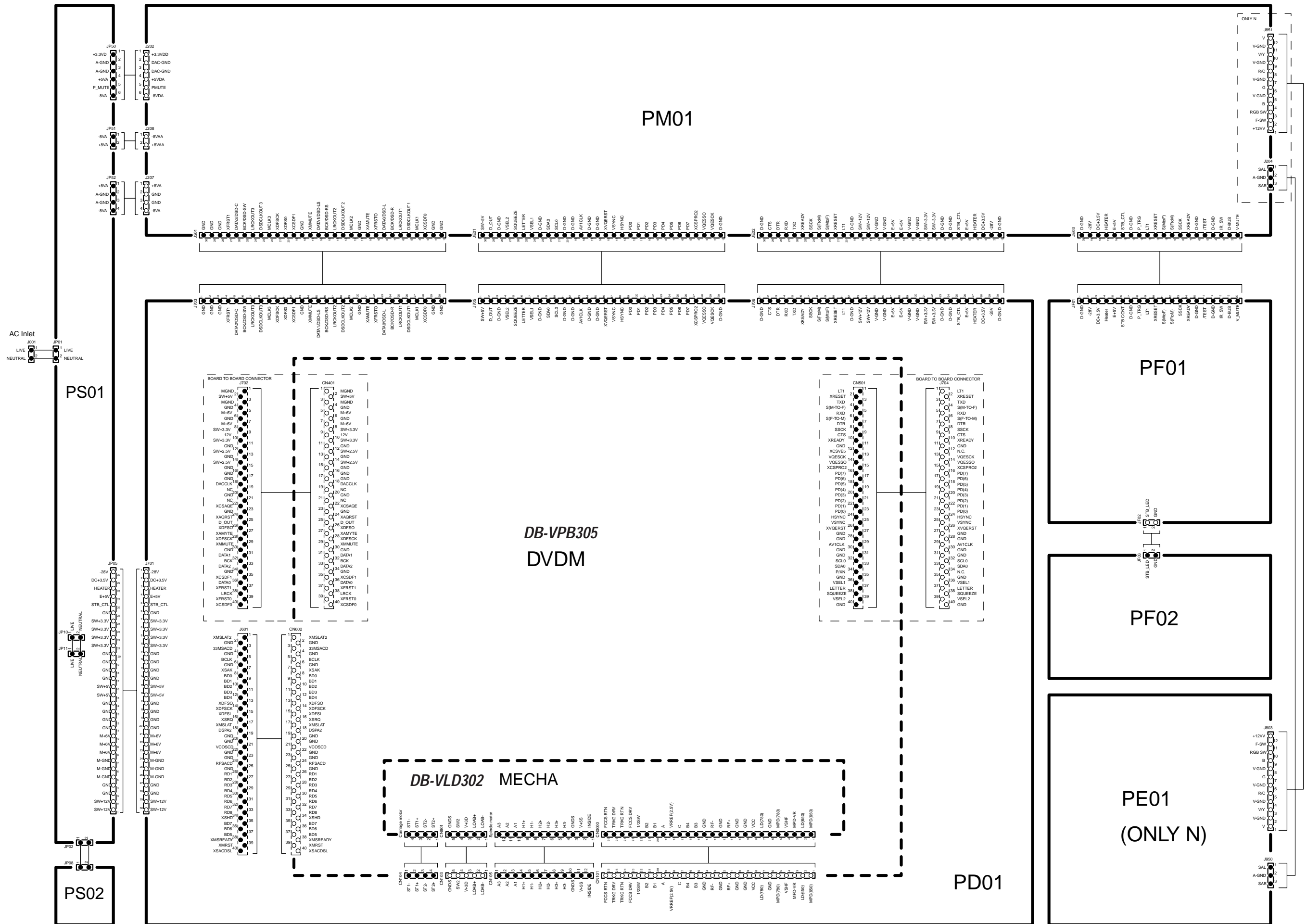

9. BLOCK DIAGRAM

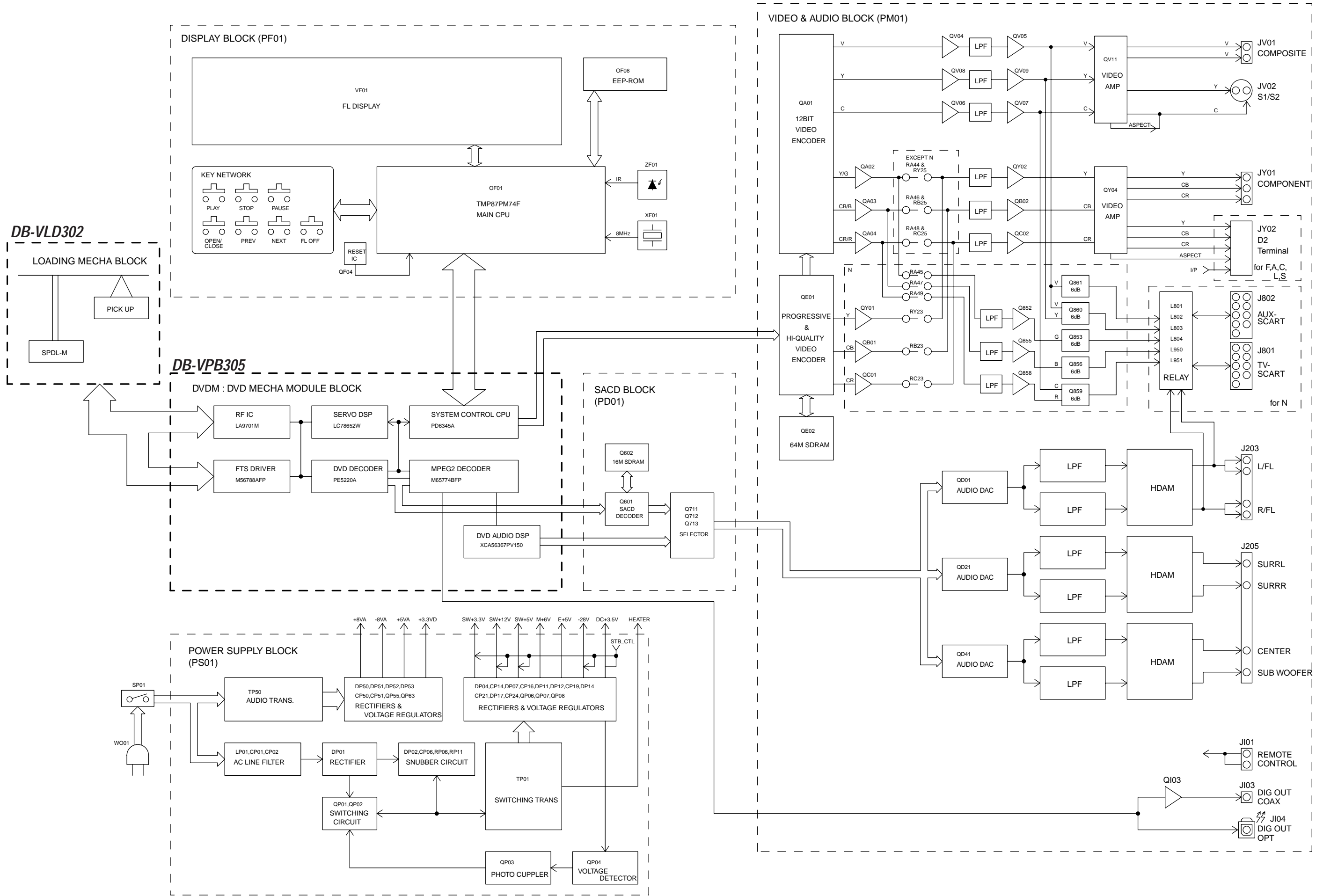

10. SCHEMATIC DIAGRAM

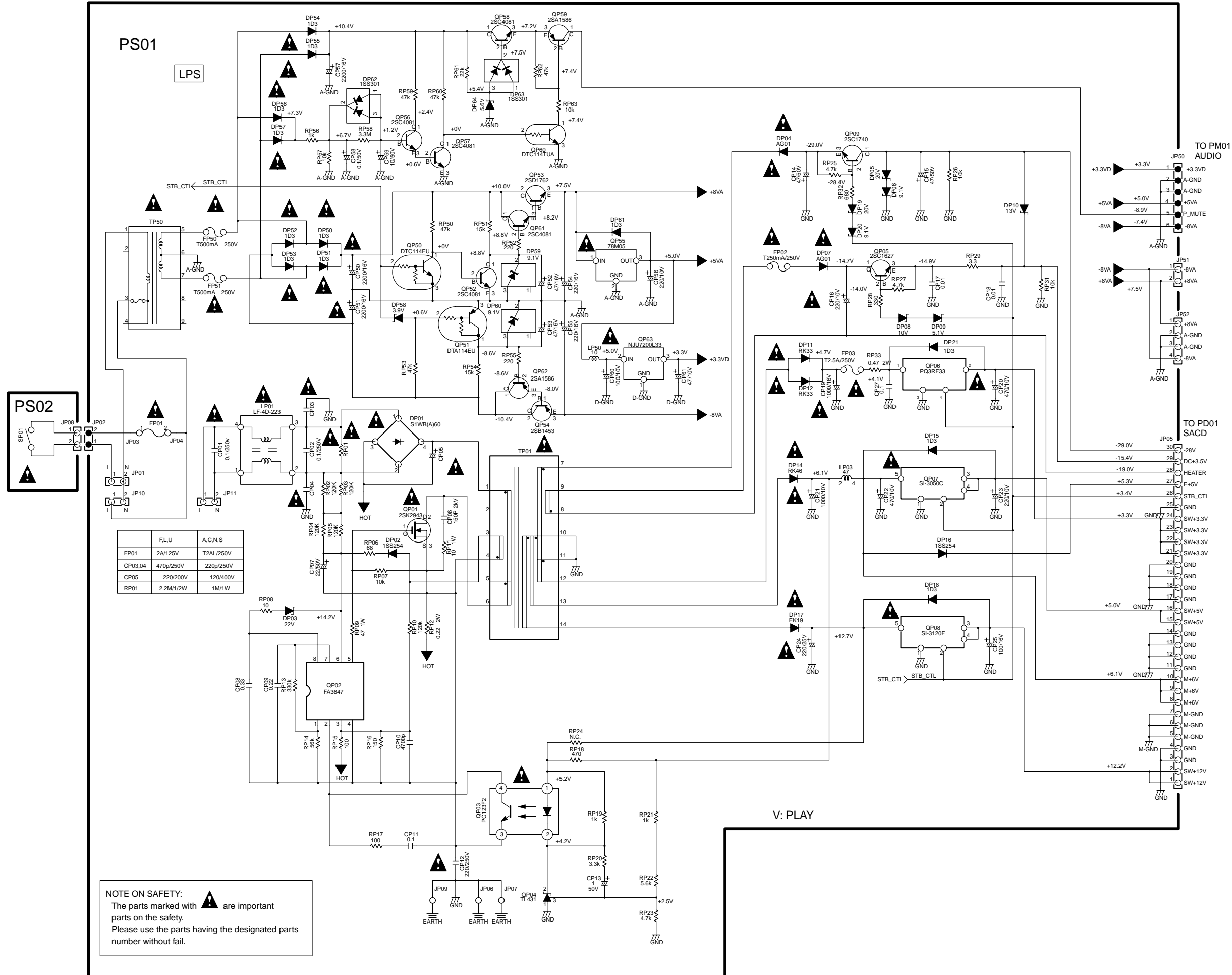

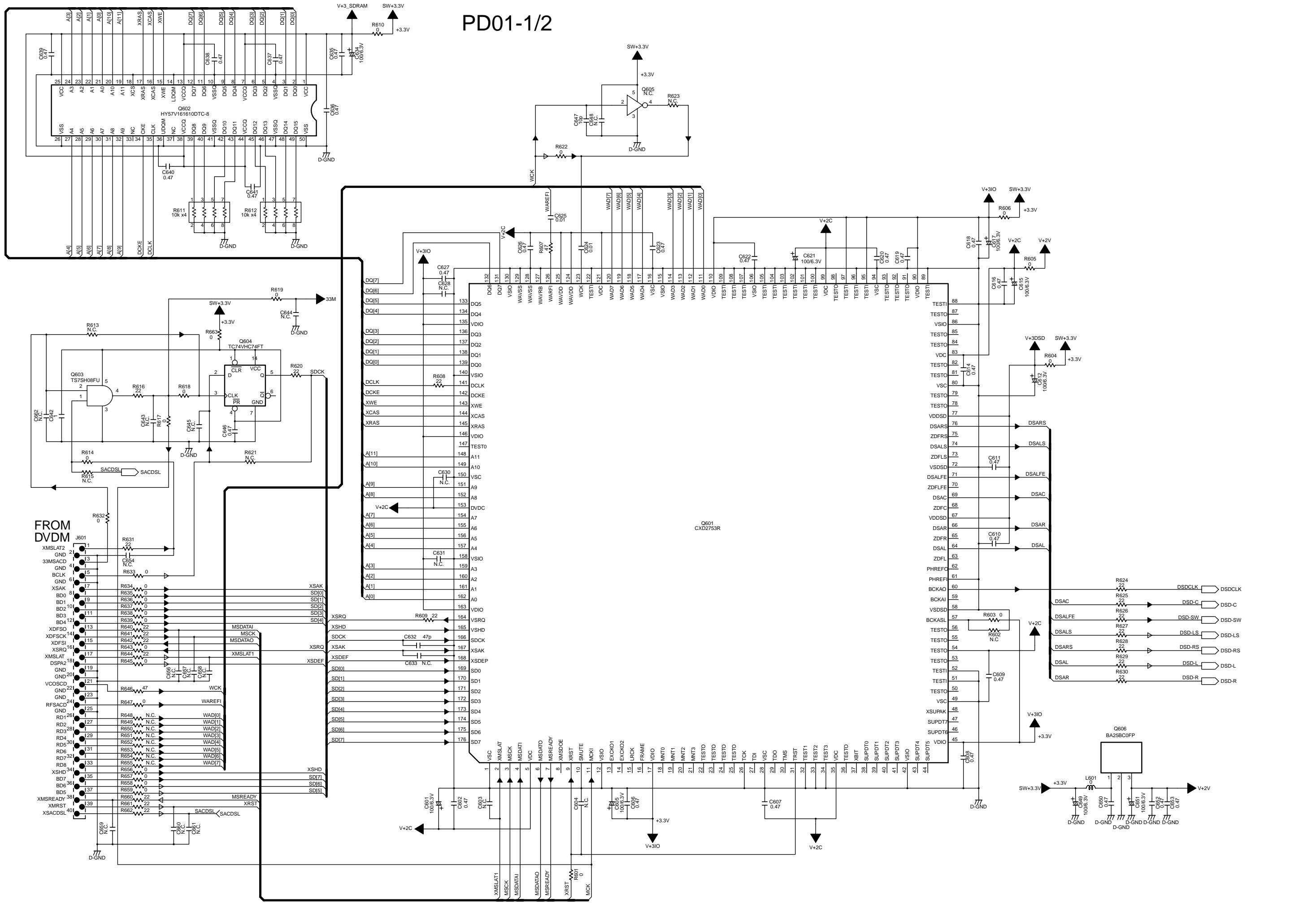

PD01-1/2



# PD01-2/2

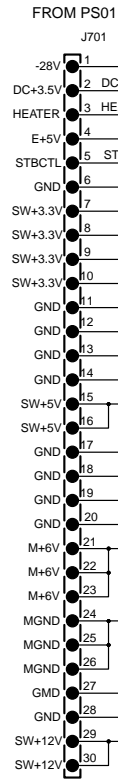

## FROM MECHA

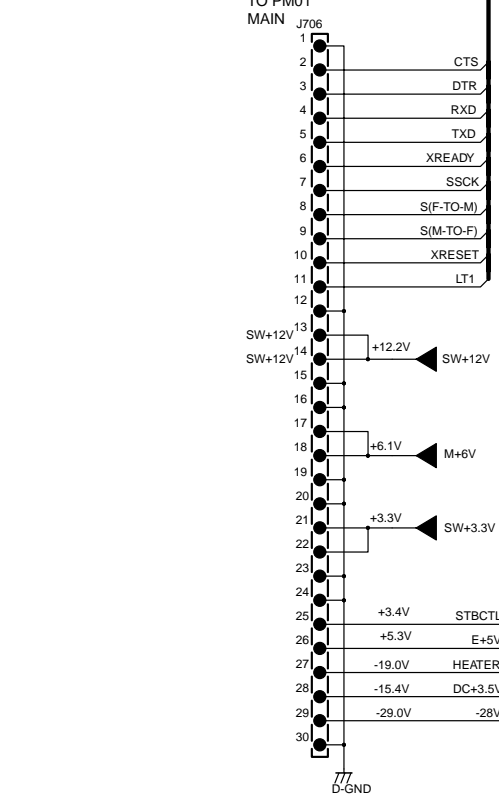
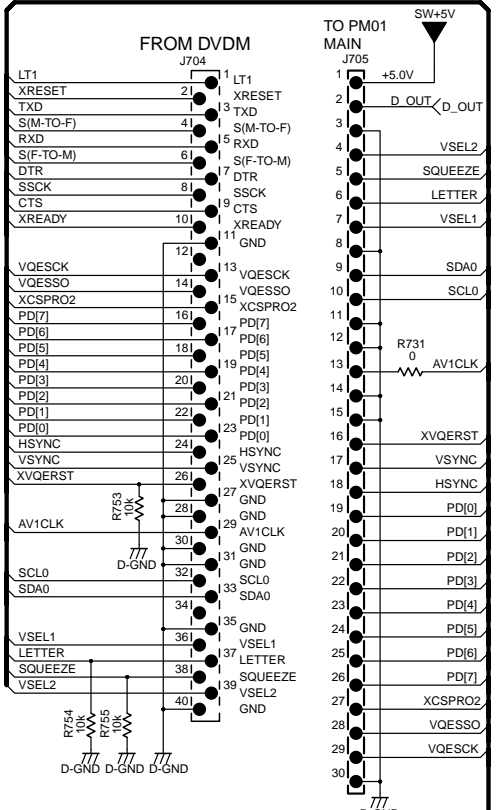
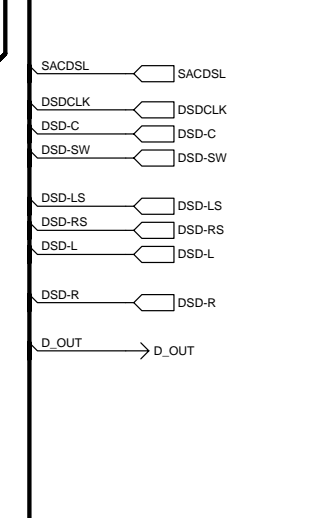
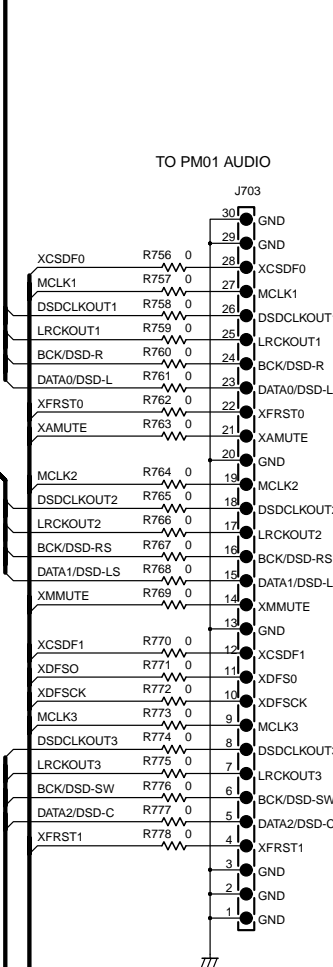
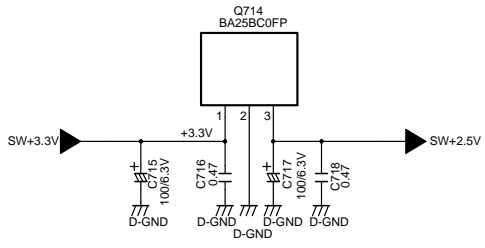
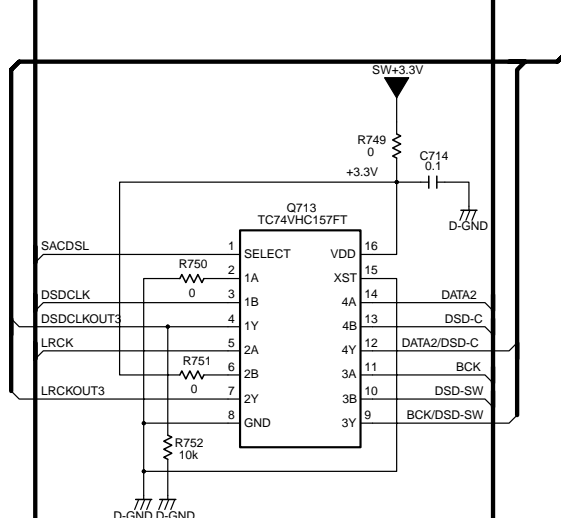
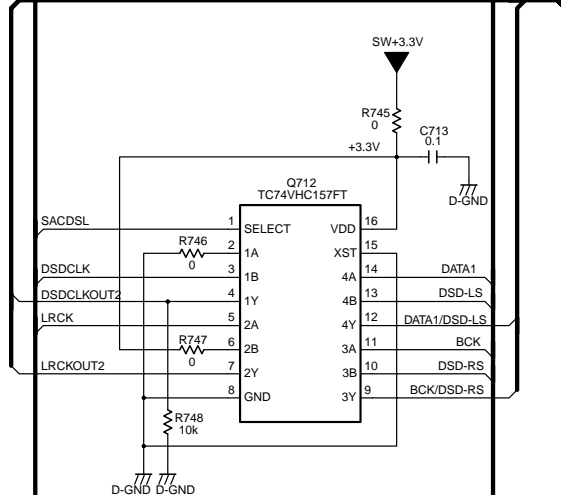
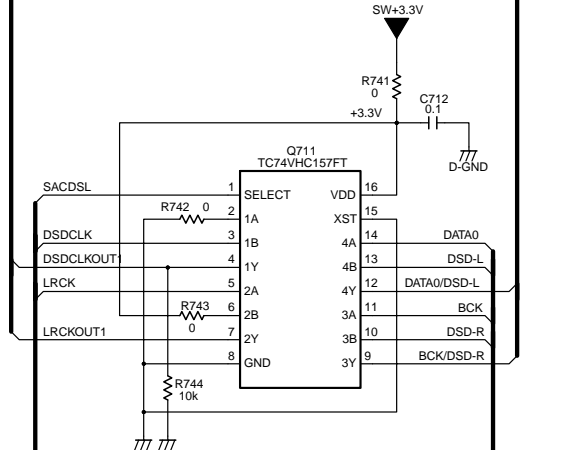
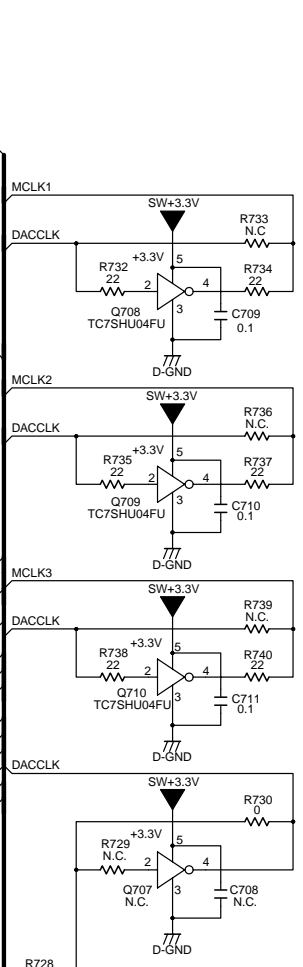
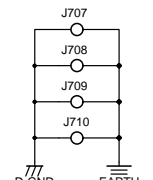
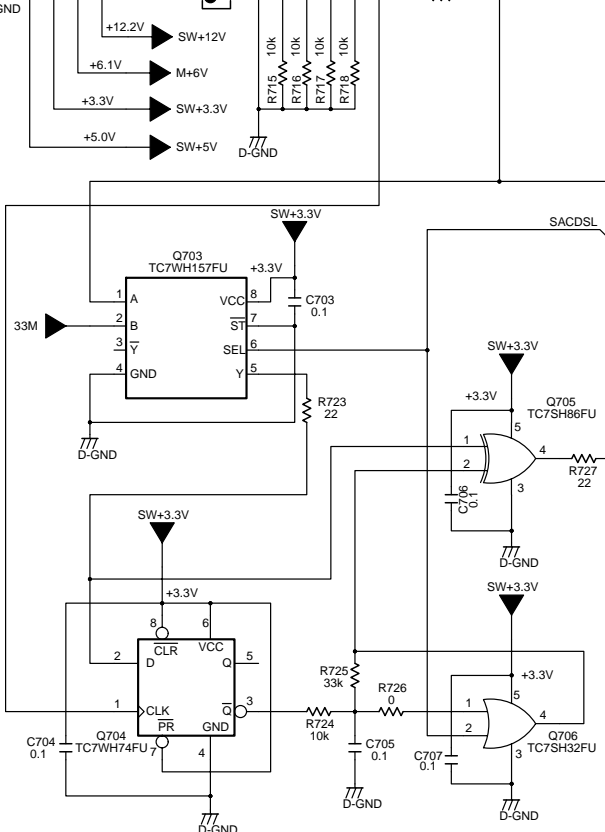
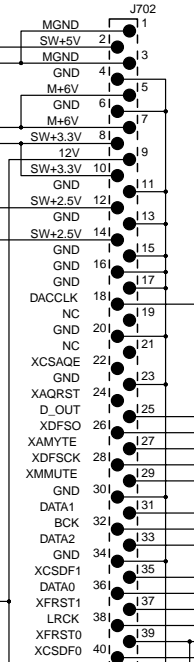

# PM01-1/5

FROM PD01

FROM PS01

-8VA

+8VA

+8VA

-8VA

+8VA

-8VA

+8VA

-8VA

+8VA

-8VA

+8VA

-8VA

+8VA

-8VA

+8VA

-8VA

+8VA

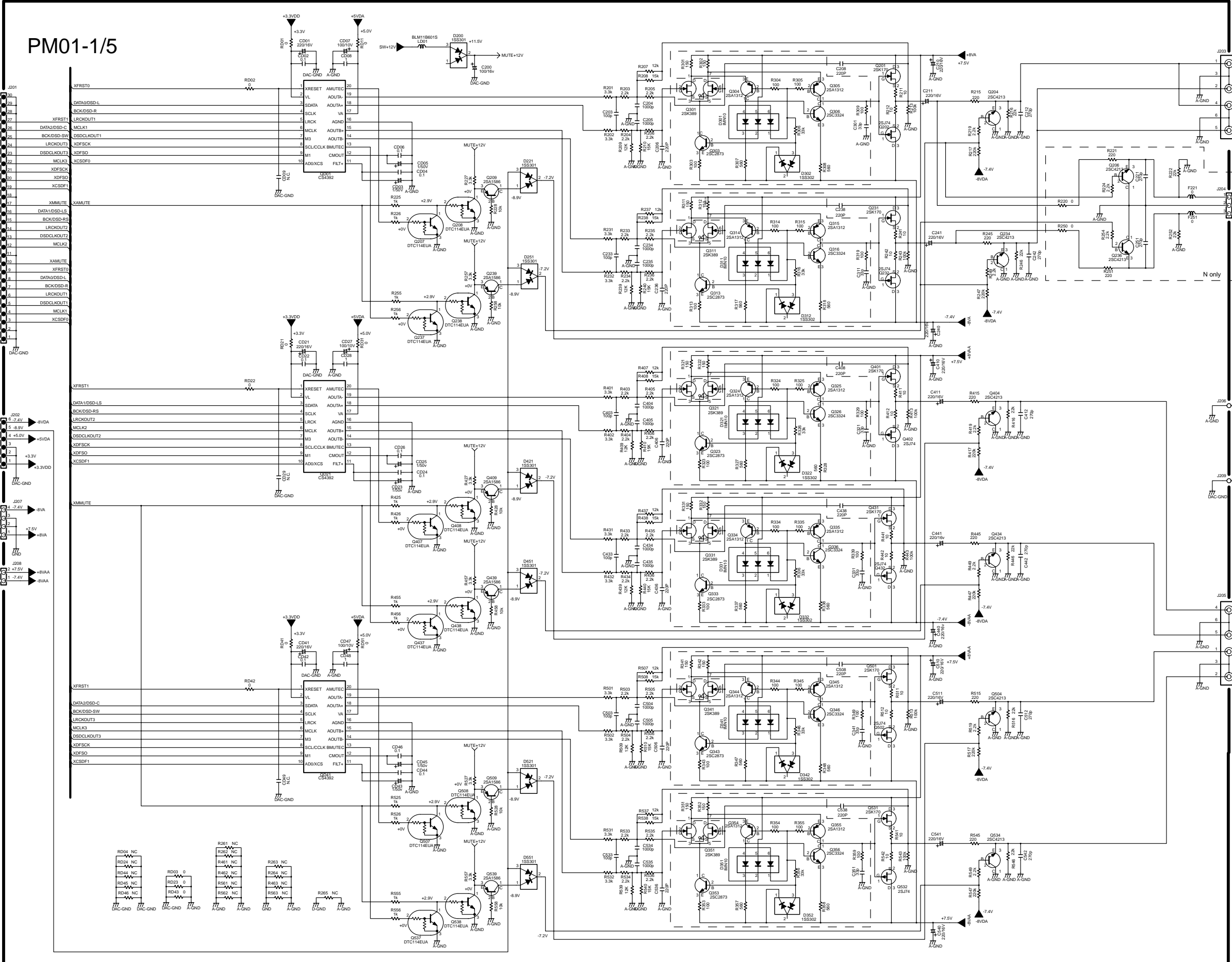

L  
R  
FL  
FR

N only

J206  
EARTH

J205  
SL  
SR  
C  
SW

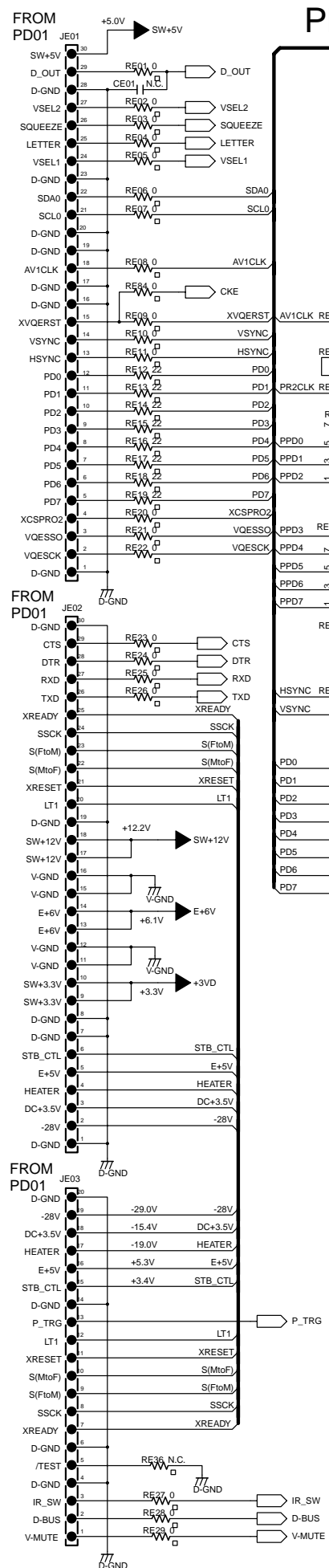

# PM01-2/5

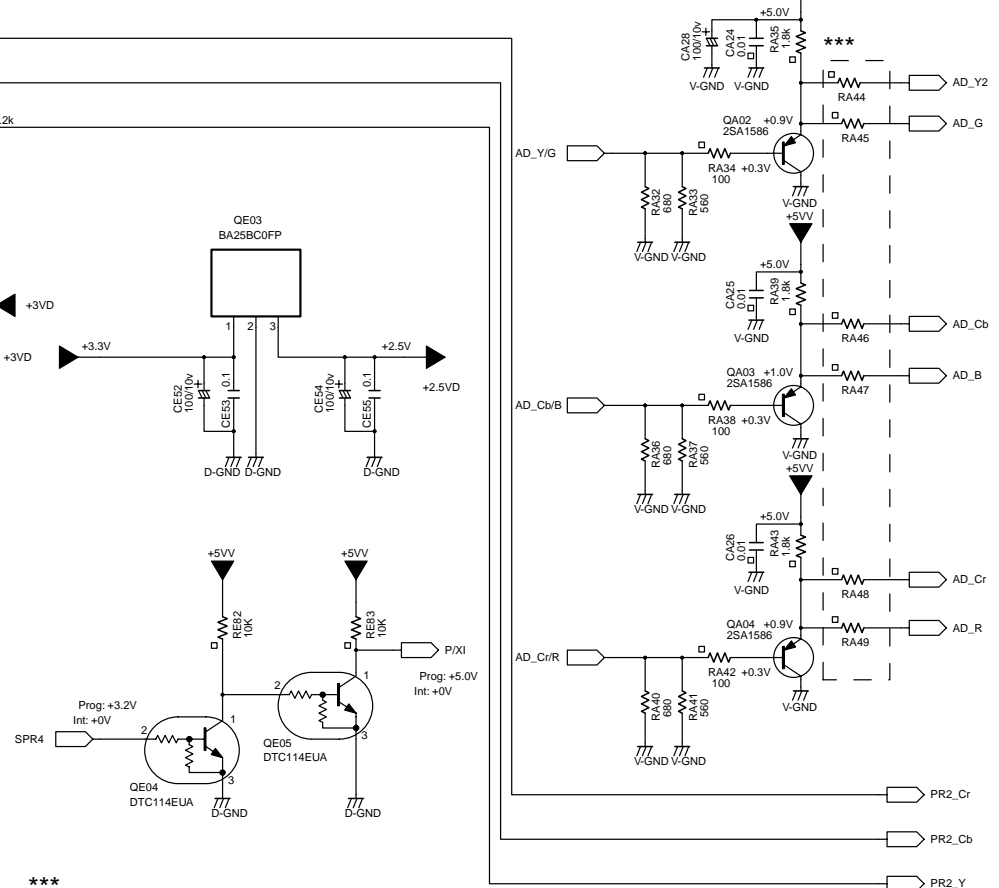
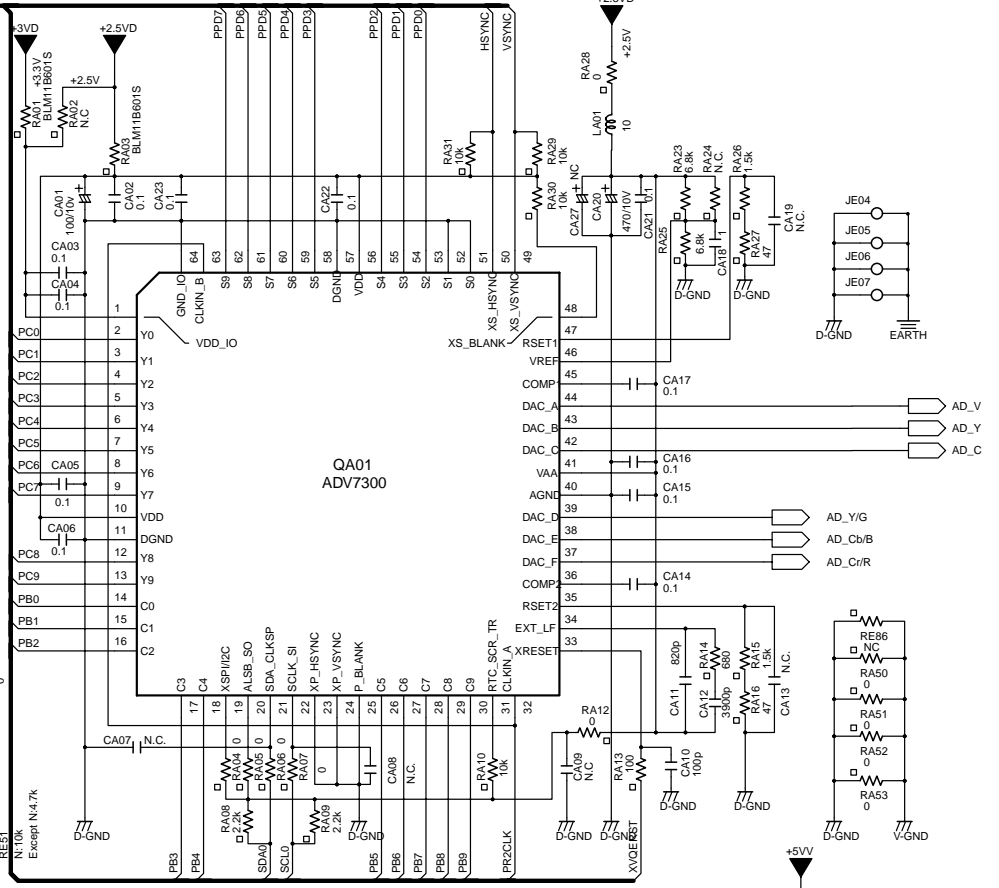
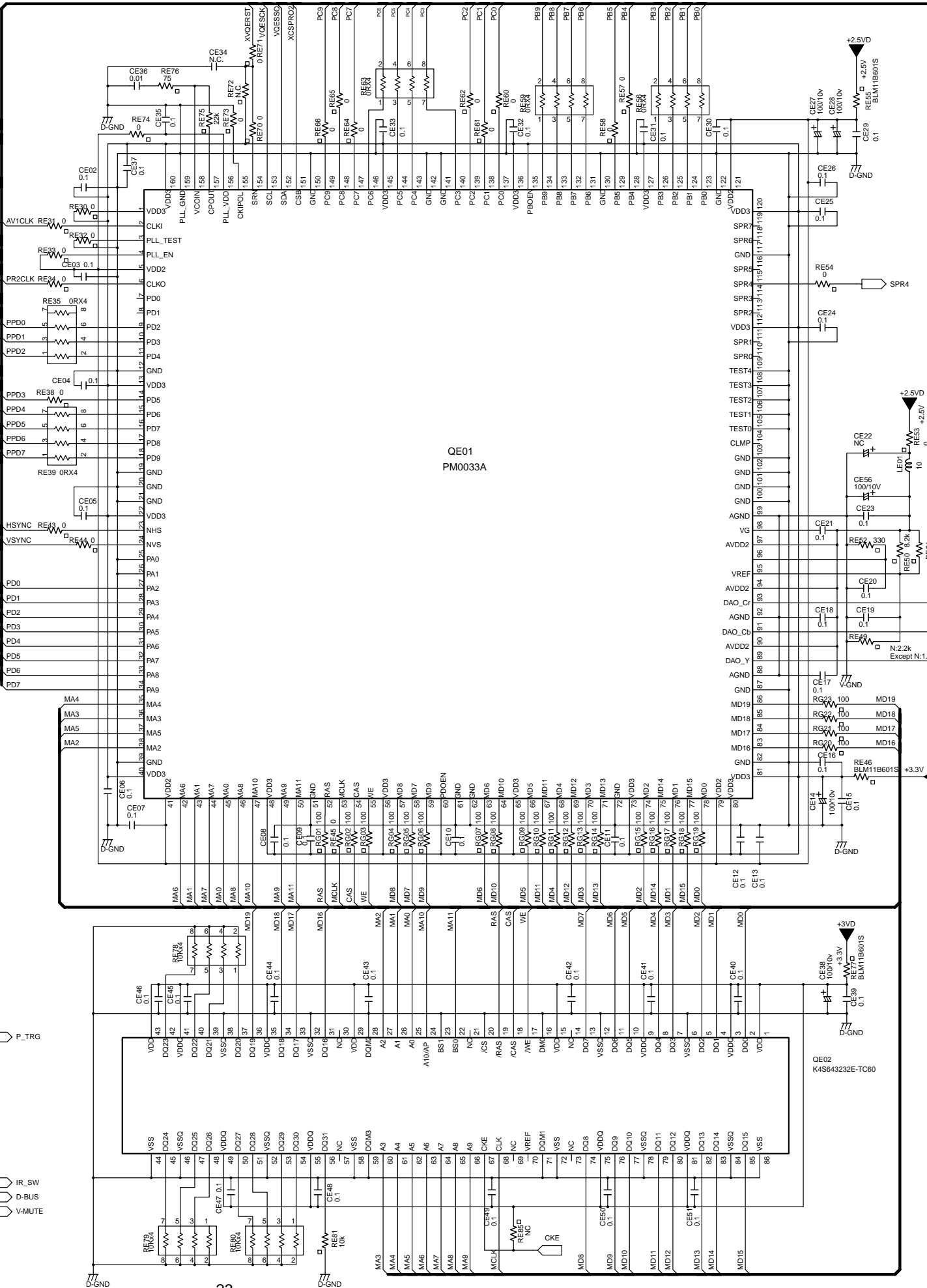

\*\*\*

	RA44	RA45	RA46	RA47	RA48	RA49
EXCEPT N	0	NC	0	NC	0	NC
N	NC	0	NC	0	NC	0

# PM01-3/5

\*\*\*

	RV05	RV06	RV12	RV13	RV19	RV20	RV28	RV29
N ONLY	680	560	680	560	680	560	NC	0
EXCEPT N	470	470	470	470	470	470	0	NC

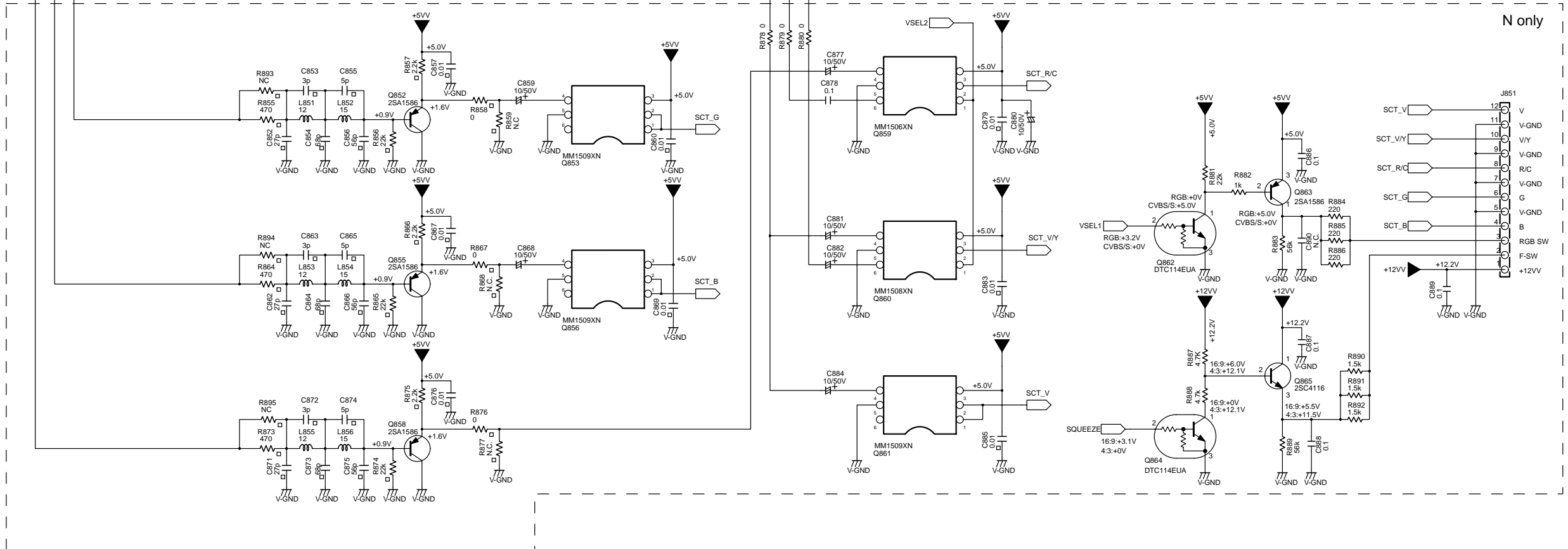
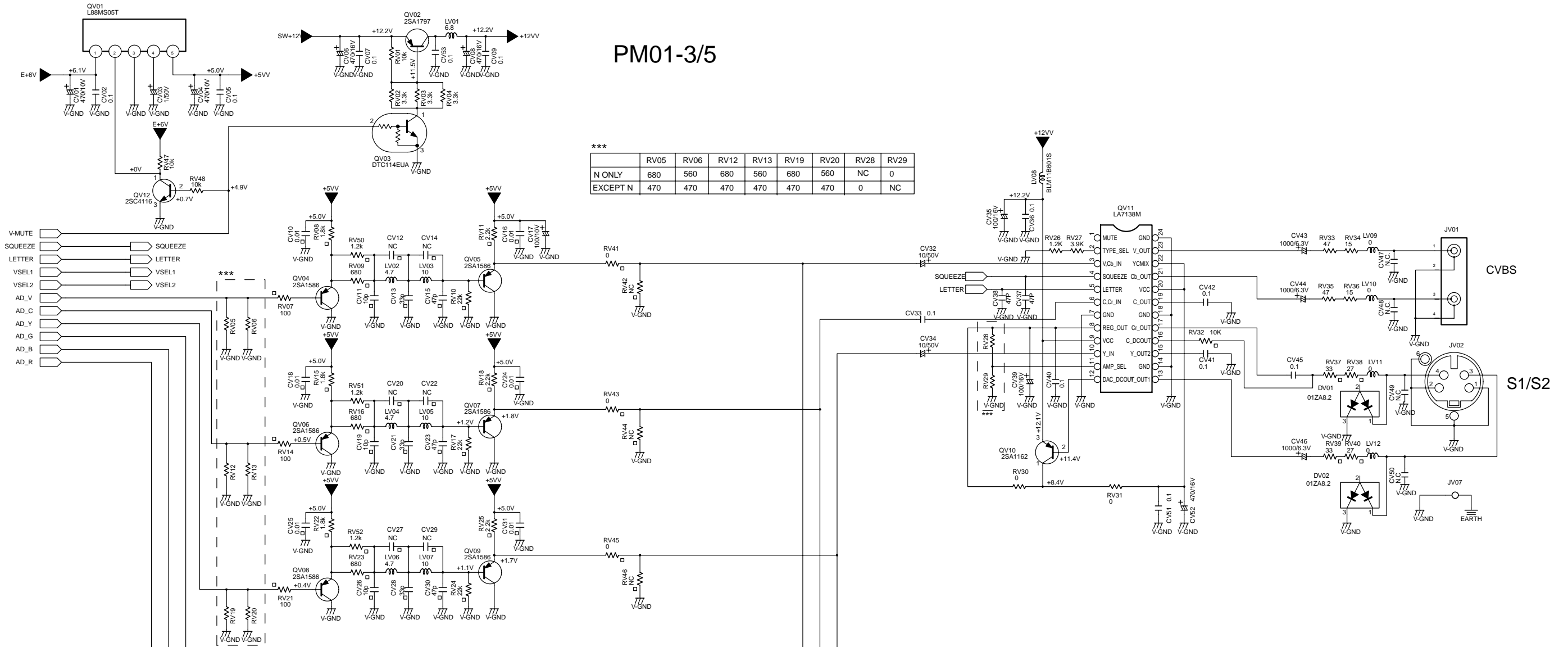

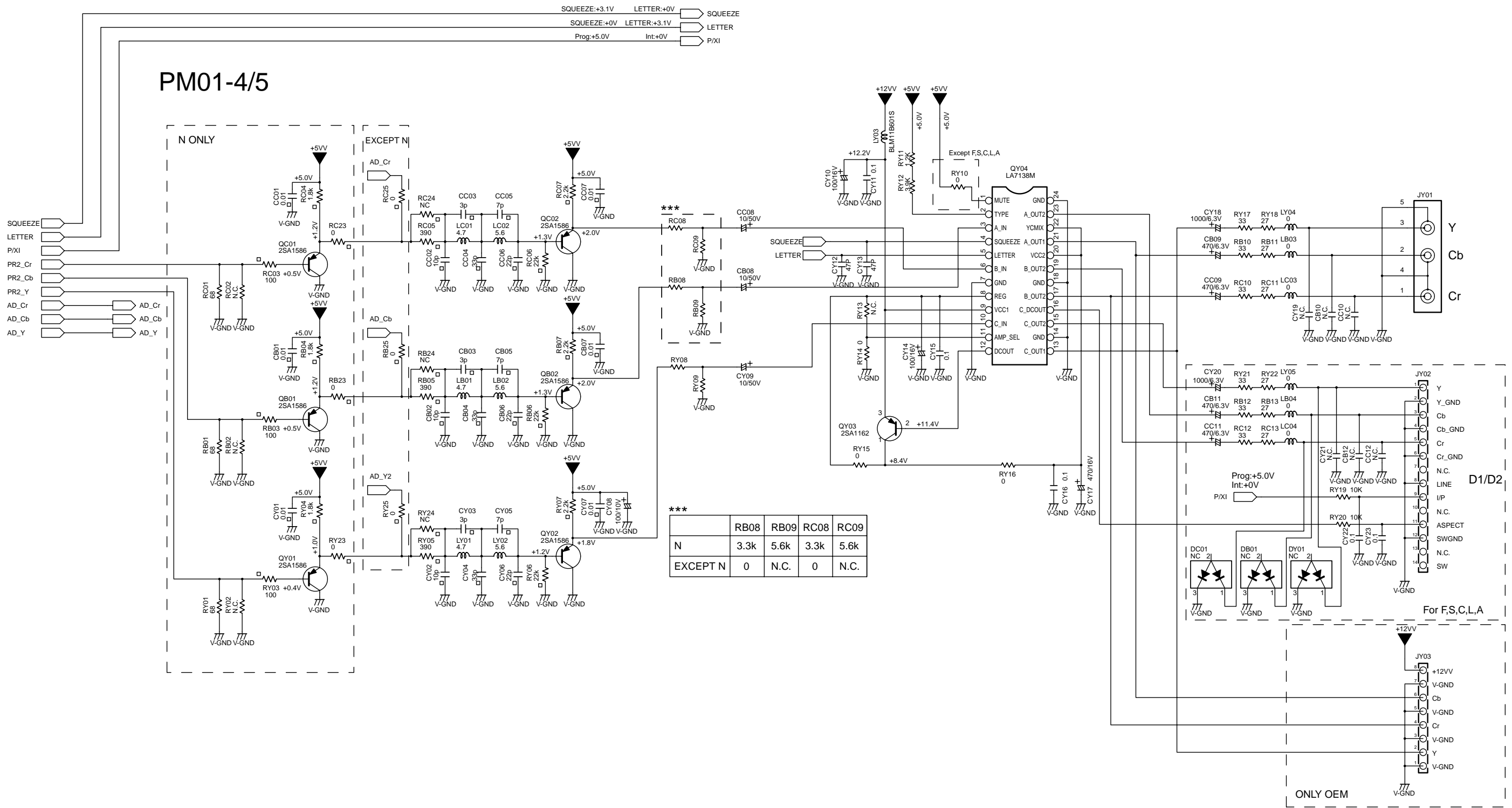

# PM01-5/5

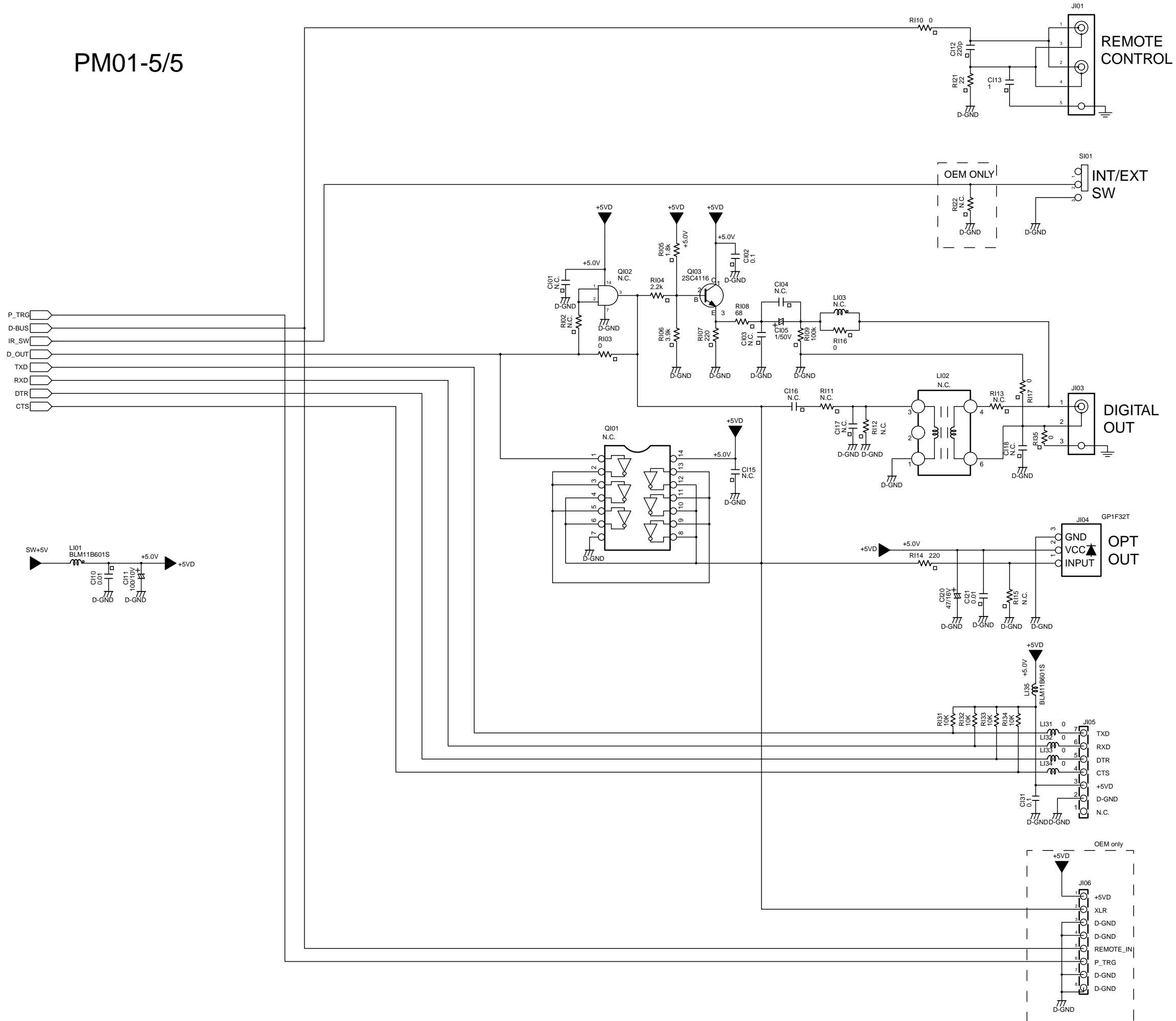

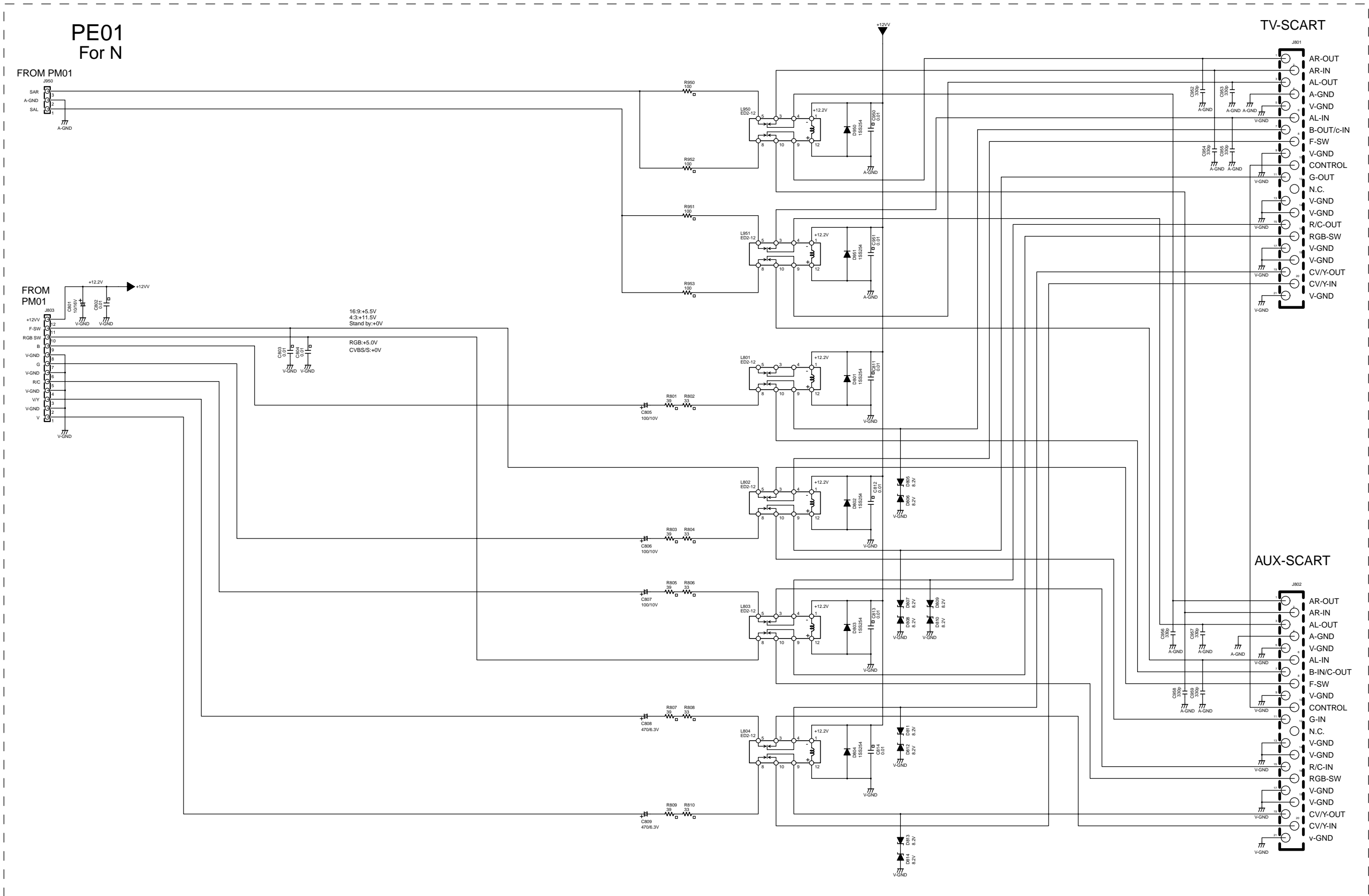

# PF01

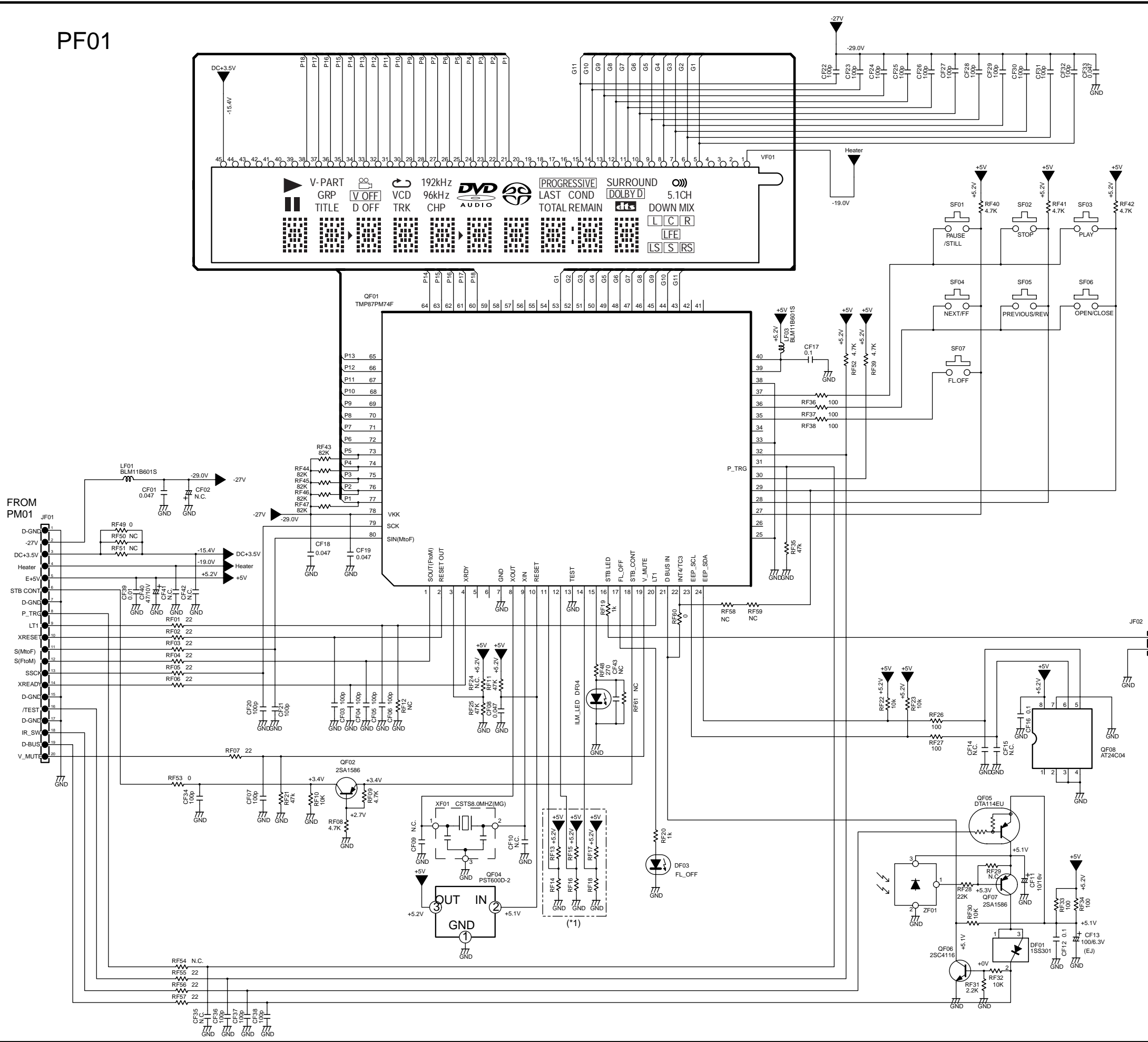

(\*1)  
QF01 Pin No.11,12,14 SETTING

Region	Distination	Pin No. MS1	11	12	14
2	JAPAN	0	L	L	L
1	USA	1	H	L	L
4	AUS	2	L	H	L
3	ASIA	2	H	H	L
2	EURO	4	L	L	H
5	--	4	H	L	H
6	CHINA	2	H	H	H

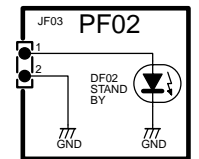



# 11. PARTS LOCATION

PM01

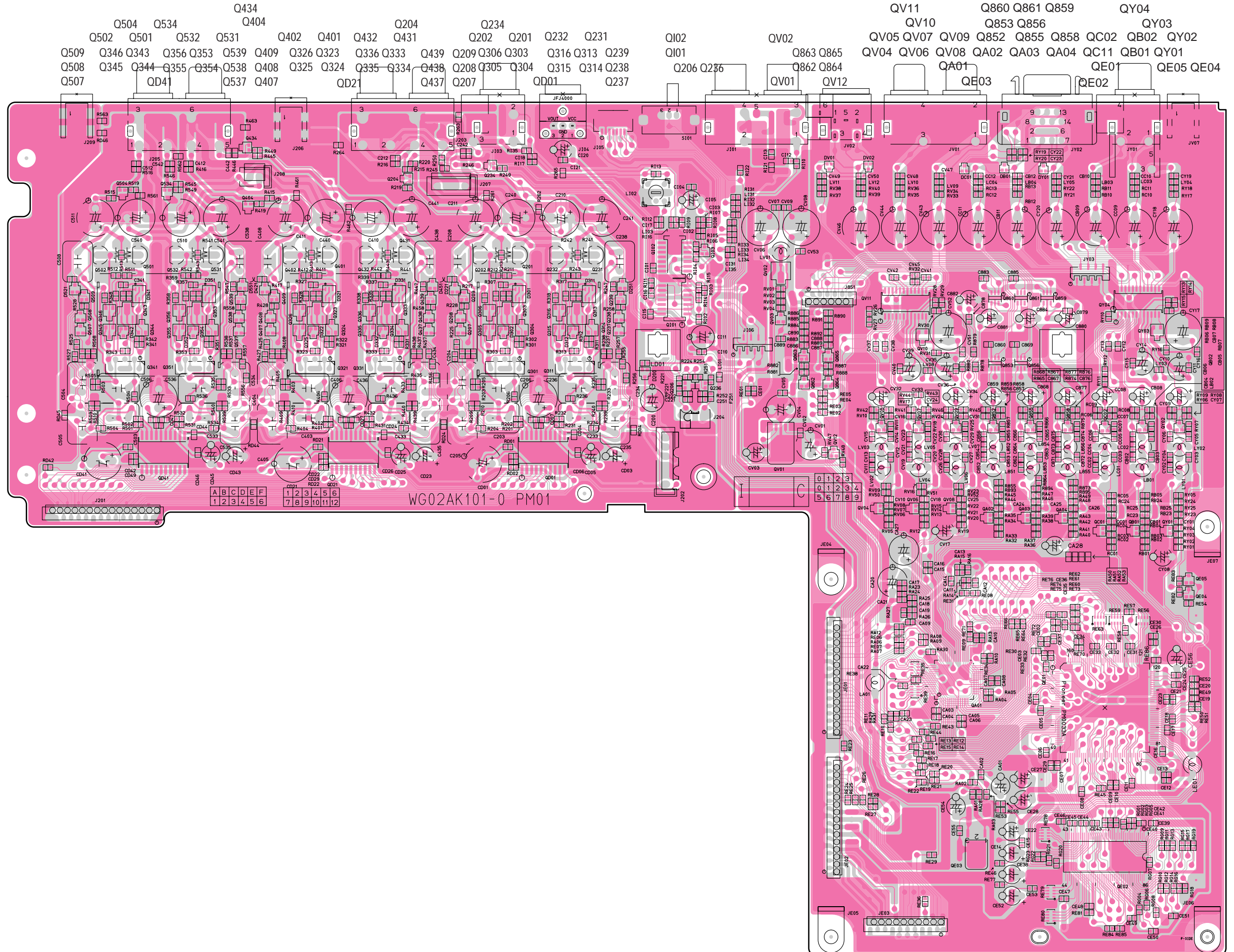

PD01

Q710 Q709 Q708 Q707  
Q702 Q701

Q703 - Q706  
Q603 Q604

Q713

Q712

Q711

Q602

Q601

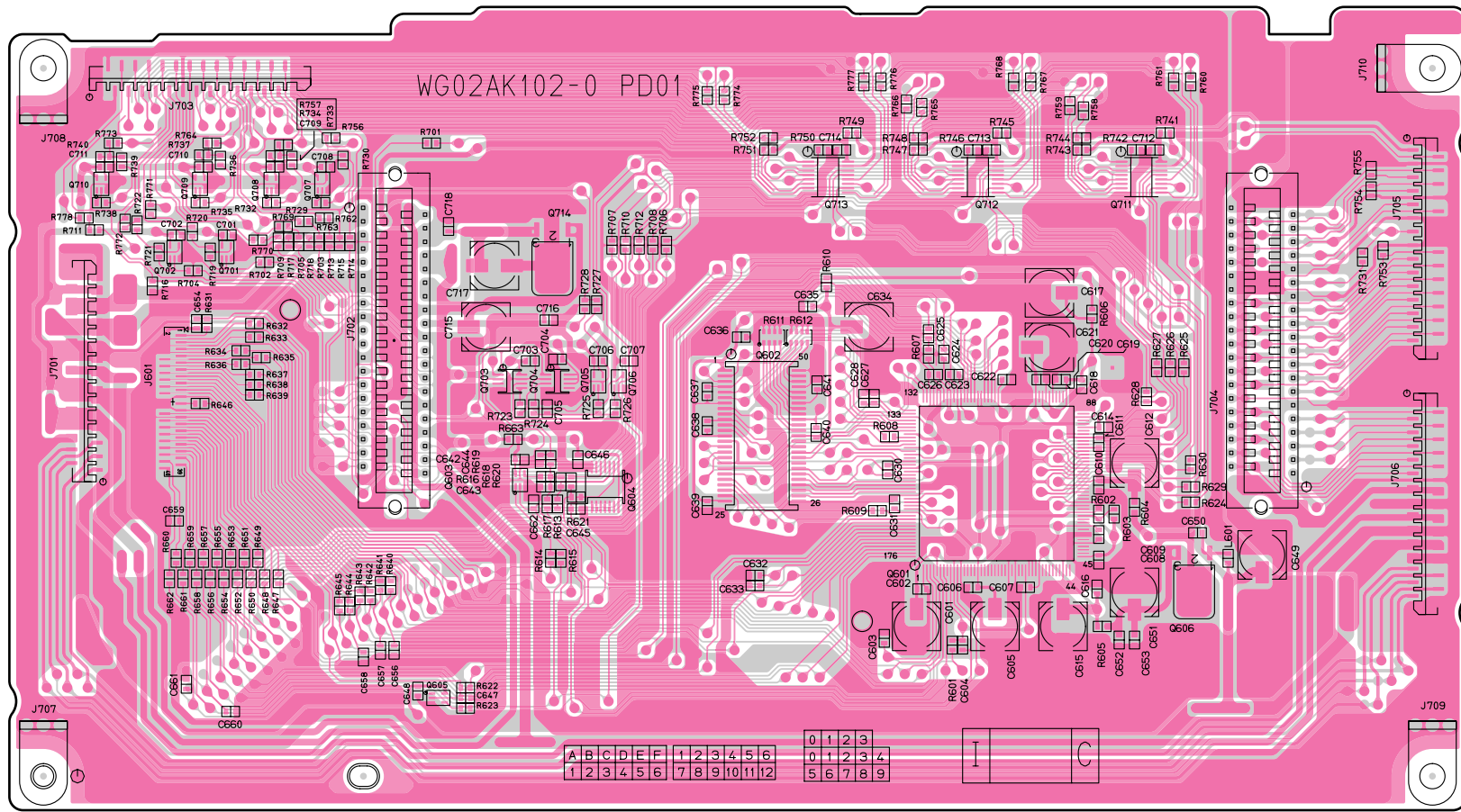

PF01

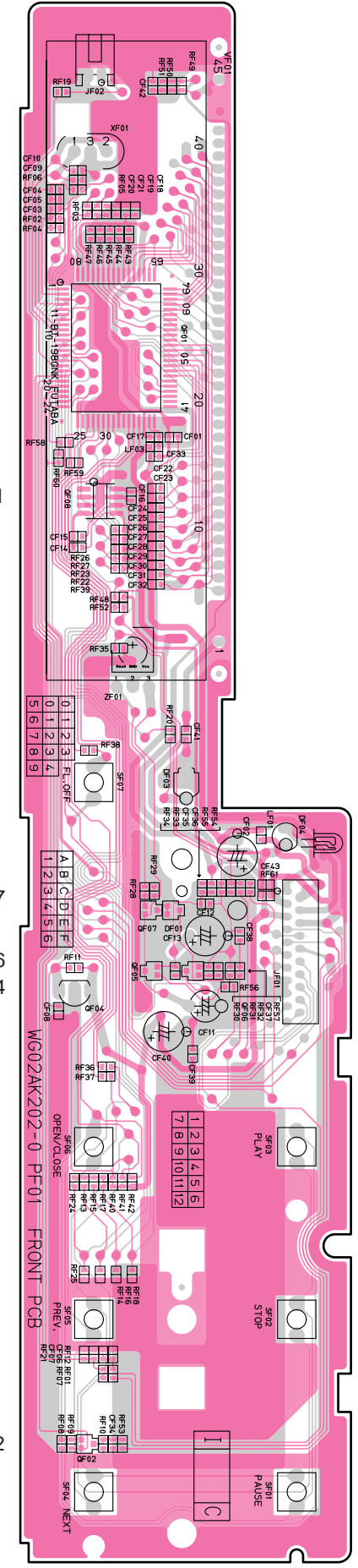

PS01

QP05 QP09

QP02

QP01

QP04

QP06 QP07

QP08

QP54

QP51 QP61 QP62

QP53

QP63

QP50 QP52 QP56 - QP60

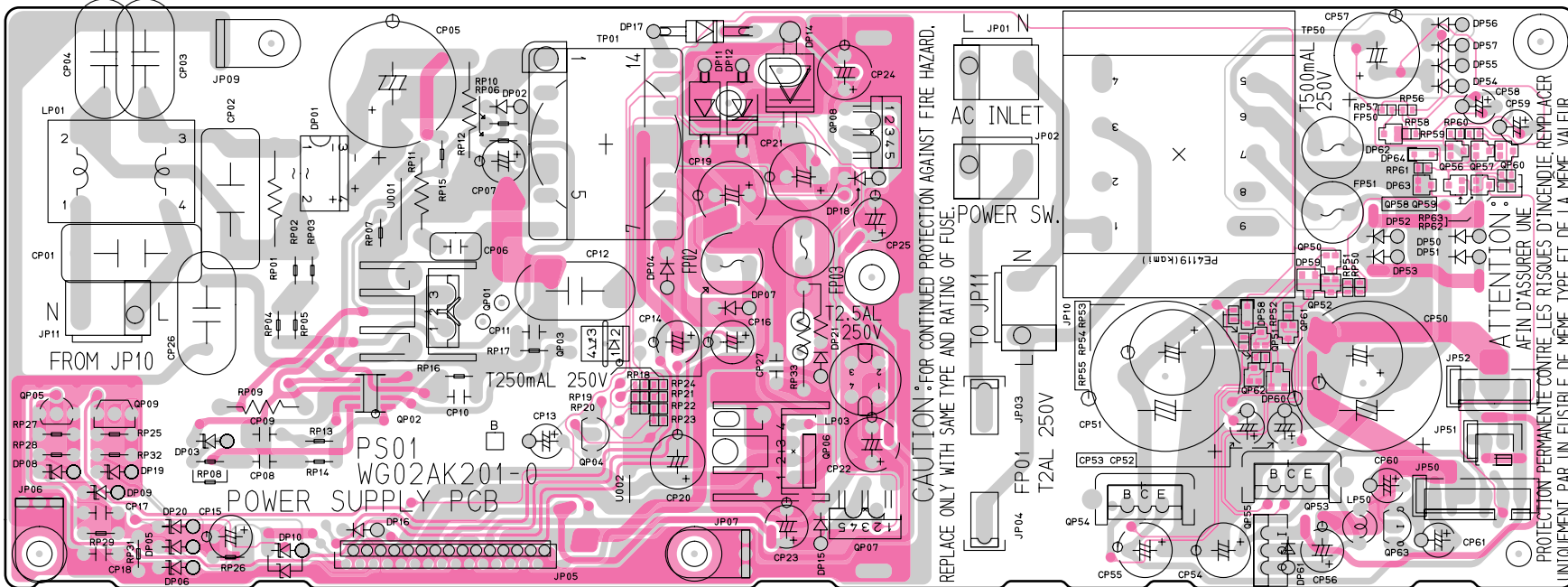

QF01

QF07

QF05 QF06

QF04

QF02

PE01 [N ONLY]

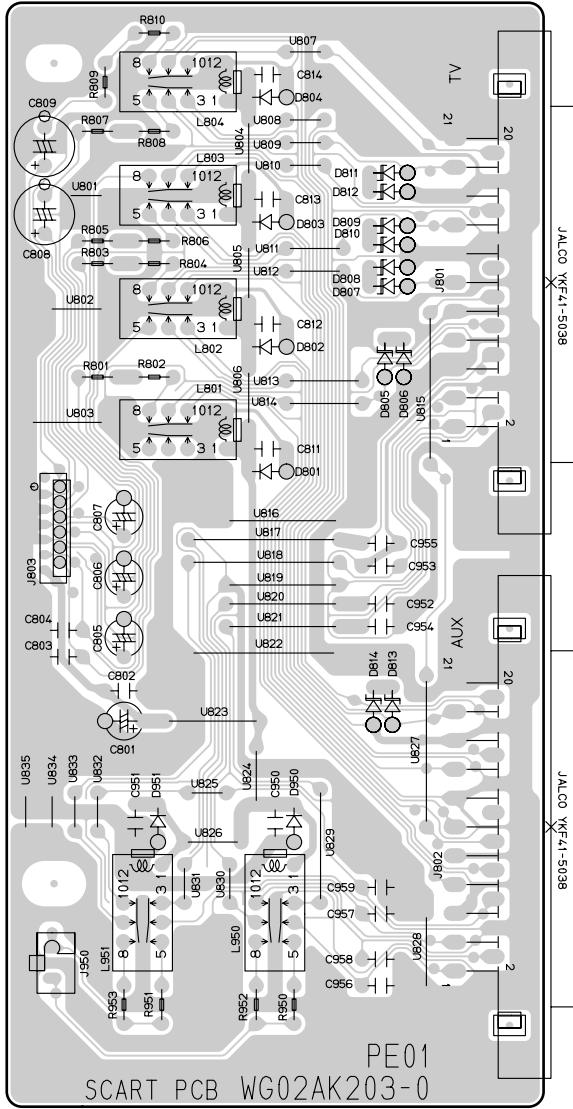

PS02

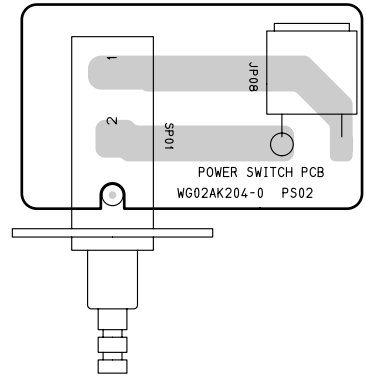

PF02

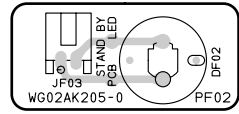

## 12 MICROPROCESSOR AND IC DATA

### QF01:TMP87CM71F

Pin	PORT	Signal name	I/O	Contents of control	
1	P02/SO1	SOUT (F to M)	O	Serial bus data output for DV747	
2	P03	RESET_OUT	O	For the DV747 RESET terminal control	RESET: L
3	P04	DV8300/DV8310	I	Setup of Model	Circuit diagram reference
4	P05	XRDY	O	Serial data communication request signal for DV747	High: request /Low: no
5	P06	N C			
6	P07	N C			
7	VSS			GND	
8	XOUT			8MHz X'TAL	
9	XIN			8MHz X'TAL	
10	RESET	RESET	I	Reset signal for the microcomputer	
11	P22	MODEL1	I	Set up of version	Circuit diagram reference
12	P21	MODEL2	I	Set up of version	Circuit diagram reference
13	TEST			GND	
14	P20	MODEL3	I	Set up of version	Circuit diagram reference
15	P10	ILM_LED	O	ILM LED for FL	Light burned: H
16	P11	STB_LED	O	It is light at the STANDBY	Light burned: H
17	P12	FL_OFF_LED	O	Lighting (FL Lights-out)	Light burned: H
18	P13	STB_CONT	O	Power supply control for DV747	Stand-by time: LOW
19	P14	V_MUTE	O	Mute control for Video	At the time of Mute: L
20	P15	LT1	I	Serial bus data Ready/Busy input for DVD747	High: Ready/Low: Busy
21	P16	D_BUS_IN	I	D-BUS input	
22	P17/TC3	IR	I	IR sensor input	
23	P30	SCL	O	I2C clock (EEPROM control)	AT24C04
24	P31	SDA	I/O	I2C data (EEPROM control)	AT24C04
25	P32			GND	
26	P40	N C			FL Lights-out
27	P41	KEY_IN_0	I	Key matrix input (Tactile switch)	
28	P42	KEY_IN_1	I	Key matrix input (Tactile switch)	
29	P43	KEY_IN_2	I	Key matrix input (Tactile switch)	
30	P44	KEY_IN_3	I	Key matrix input (Tactile switch) spare	
31	P45	PowerTrigger	I	By the AD change, Power decision	Setup of Model is Linkage with
32	P46	SreviceKey	I	Service function switching	
33	P47			GND	
34	P50	KEY_OUT_0	O	Tactile switch spare	
35	P51	KEY_OUT_1	O	Tactile switch	
36	P52	KEY_OUT_2	O	Tactile switch	
37	P53	KEY_OUT_3	O	Tactile switch	
38	VASS	GND		GND for A/D	
39	VAREF	5V	O	A reference voltage for A/D	
40	VDD	5V		Power supply	

Pin	PORT	Signal name	I/O	Contents of control	
41	P60	NC			
42	P61	NC			
43	P62	G11	O	FL indication	
44	P63	G10	O	FL indication	
45	P64	G9	O	FL indication	
46	P65	G8	O	FL indication	
47	P66	G7	O	FL indication	
48	P67	G6	O	FL indication	
49	P70	G5	O	FL indication	
50	P71	G4	O	FL indication	
51	P72	G3	O	FL indication	
52	P73	G2	O	FL indication	
53	P74	G1	O	FL indication	
54	P75	N C			
55	P76	N C			
56	P77	N C			
57	P80	N C			
58	P81	N C			
59	P82	N C			
60	P83	P18	O	FL indication	
61	P84	P17	O	FL indication	
62	P85	P16	O	FL indication	
63	P86	P15	O	FL indication	
64	P87	P14	O	FL indication	
65	P90	P13	O	FL indication	
66	P91	P12	O	FL indication	
67	P92	P11	O	FL indication	
68	P93	P10	O	FL indication	
69	P94	P9	O	FL indication	
70	P95	P8	O	FL indication	
71	P96	P7	O	FL indication	
72	P97	P6	O	FL indication	
73	PD00	P5	O	FL indication	
74	PD01	P4	O	FL indication	
75	PD02	P3	O	FL indication	
76	PD03	P2	O	FL indication	
77	PD04	P1	O	FL indication	
78	VKK	-27V		Power supply for the FL drive	
79	P00/SCK1	SCK	O	Serial bus clock output for DV747	
80	P01/SI1	SIN (M to F)	I	Serial bus data input for DV747	

## QA01 : ADV7300KST

- Video Encoder IC
- Pin Arrangement

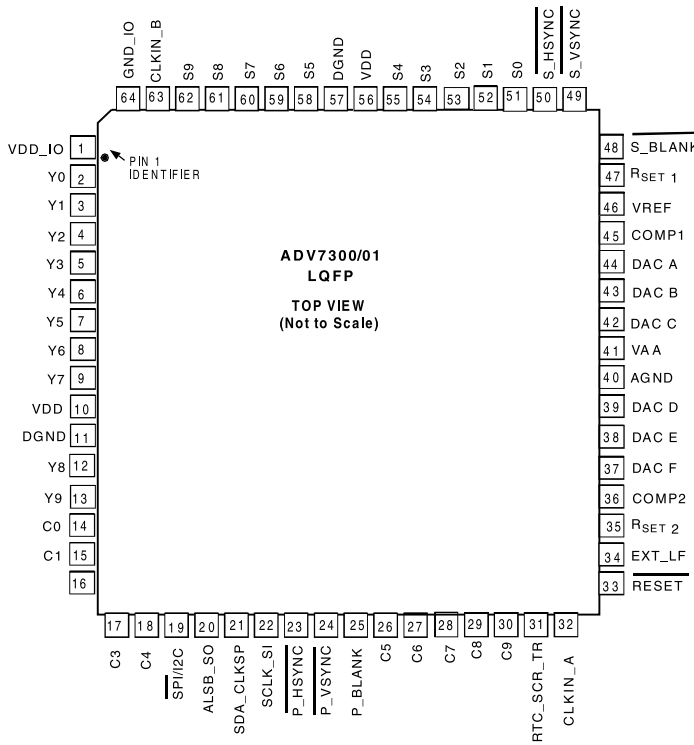

## • Pin Function

Pin Mnemonic	Input/Output	Function
DGND	G	Digital Ground
AGND	G	Analog Ground
GND_IO	G	Digital Ground
CLKIN_B	I	Pxel Clock Input. Requires a 27MHz reference clock for Progressive Scan Mode or a 74.25MHz (74.1758MHz) reference clock in HDTV mode. This clock input pin is only used in simultaneous SD and HD mode.
CLKIN_A	I	Pxel Clock Input for HD only or SD only modes.
COMP	O	Compensation Pin for DACs. Connect 0.1μF Capacitor from COMP pin to V <sub>AA</sub> .
DAC A	O	CVBS/ GREEN/ Y SD analog output.
DAC B	O	Luma/ BLUE/ U SD analog output.
DAC C	O	Chroma/ RED/ V SD analog output.
DAC D	O	in SD only mode: CVBS/GREEN/ Y analog output in HD only mode and simultaneous HD/SD : Y/ GREEN (HD) analog output.
DAC E	O	in SD only mode: Luma/BLUE/ U analog output in HD only mode and simultaneous HD/SD : Pr/ RED (HD) analog output.

Pin	Mnemonic	Input/Output	Function
DAC F		O	in SD only mode: Chroma/RED/ V analog output in HD only mode and simultaneous HD/SD : Pb/ BLUE (HD) analog output.
P_BLANK		I	Video Blanking Control Signal for HD sync in simultaneous SD/HD mode and HD HD only mode.
$\overline{P\_HSYNC}$		I	Video Horizontal Sync Control Signal for HD sync in simultaneous SD/HD mode and HD only mode.
$\overline{P\_VSYNC}$		I	Video Vertical Sync Control Signal for HD sync in simultaneous SD/HD mode and HD only mode.
$\overline{S\_BLANK}$		I/O	Video Blanking Control Signal for SD.
$\overline{S\_HSYNC}$		I/O	Video Horizontal Control Signal for SD. Option to o/p SD HSYNC or HD HSYNC in SD Slave Mode 0 and/or any HD mode.
$\overline{S\_VSYNC}$		I/O	Video Blanking Control Signal for SD. Option to o/p SD VSYNC or SD HSYNC in SD Slave Mode 0 and/or any HD mode.
C9-0		I	10-Bit Progressive scan/ HDTV input port for CrCb color data in 4:2:2 input mode. In 4:4:4 input mode this input port is used for the Cb [Blue/U] data. The LSBs are set up on pins C0, C1. In default mode the input on this port is output on DAC E.
Y9-0		I	10-Bit Progressive scan/ HDTV input port for Y data. The LSBs are set up on pins Y0, Y1. In default mode the input on this port is output on DAC D.
S9-S0		I	10-Bit Standard Definition input port. Or Progressive Scan/ HDTV input port for Cr [Red/V] color data in 4:4:4 input mode. The LSBs are set up on pins S0, S1. In default mode the input on this port is output on DAC F.
$\overline{RESET}$		I	This input resets the on-chip timing generator and sets the ADV7300/01 into Default Register setting. Reset is an active low signal.
R <sub>SET1,2</sub>		I	A 1520 Ohms resistor must be connected from this pin to AGND and is used to control the amplitudes of the DAC outputs.
SCL_SI		I	Multifunctional input: MPU Port Serial Interface Clock Input or SPI input.
SDA_CLKSP		I/O	Multifunctional pin: MPU Port Serial Data Input/Output or SPI clock input.
ALSB_SO		I/O	Multifunctional pin. TTL Address Input. This signal sets up the LSB of the MPU address. When this pin is tied low the I2C filter is activated which reduces noise on the I2C interface. When this pin is tied high, the input bandwidth on the I2C lines is increased. SPI output.
$\overline{SPI/I2C}$		I	When this nput pin is brought low, the ADV7300/01 interfaces over the SPI port and uses this input as part of the 4 wire SPI nterface. When this input pin is tied high [Vdd_IO], the ADV7300/01 interfaces over the I2C port.
V <sub>DD_IO</sub>		P	Digital power supply
V <sub>DD</sub>		P	Digital power supply
V <sub>AA</sub>		P	Analog power supply
V <sub>REF</sub>		I/O	Optional External Voltage Reference Input for DACs or Voltage Reference Output (1.235V).
EXT_LF		I	External Loop filter for the internal PLL.
RTC_SCR_TR		I	Multifunctional Input: Real Time Control (RTC) nput, Timing Reset nput, Subcarrier Reset nput.

QE01 : PM0033A

- Progressive Scan Converter (PRO2)
- Pin Arrangement

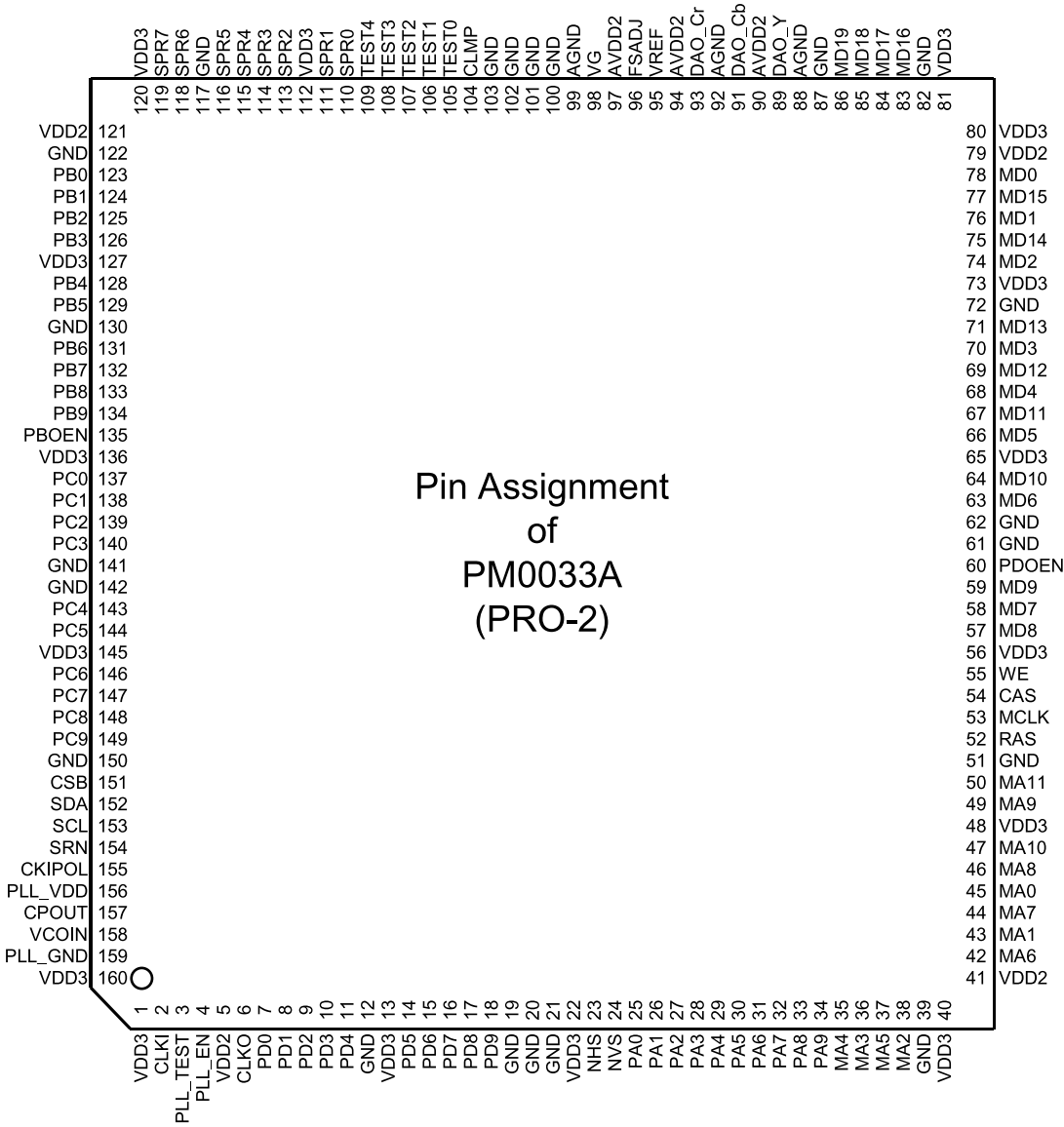



- Pin Function

Pin No.	Name	I/O/P	Attribute	Functional Description
1	VDD3	P	-	VDD for IO (3.3V)
2	CLKI	In	LVTTTL	27MHz System clock input terminal
3	PLL_TEST	In	LVTTTL	Test exclusive use input terminal
4	PLL_EN	In	LVTTTL	PLL enable input terminal
5	VDD2	P	-	VDD for Core (2.5V)
6	CLKO	Out	2mA	27MHz Clock output terminal
7	PD0	Inout	LVTTTL, leakage, 2mA	Image data I/O port D(LSB)
8	PD1	Inout	LVTTTL, leakage, 2mA	Image data I/O port D
9	PD2	Inout	LVTTTL, leakage, 2mA	Image data I/O port D
10	PD3	Inout	LVTTTL, leakage, 2mA	Image data I/O port D
11	PD4	Inout	LVTTTL, leakage, 2mA	Image data I/O port D
12	GND	P	-	Digital Ground
13	VDD3	P	-	VDD for IO (3.3V)
14	PD5	Inout	LVTTTL, leakage, 2mA	Image data I/O port D
15	PD6	Inout	LVTTTL, leakage, 2mA	Image data I/O port D
16	PD7	Inout	LVTTTL, leakage, 2mA	Image data I/O port D
17	PD8	Inout	LVTTTL, leakage, 2mA	Image data I/O port D
18	PD9	Inout	LVTTTL, leakage, 2mA	Image data I/O port D(MSB)
19	GND	P	-	Digital Ground
20	GND	P	-	Digital Ground
21	GND	P	-	Digital Ground
22	VDD3	P	-	VDD for IO (3.3V)
23	NHS	In	Schmitt	Horizontal synchronization input terminal
24	NVS	In	Schmitt	Vertical synchronization input terminal
25	PA0	In	LVTTTL	Image data I/O port A(LSB)
26	PA1	In	LVTTTL	Image data I/O port A
27	PA2	In	LVTTTL	Image data I/O port A
28	PA3	In	LVTTTL	Image data I/O port A
29	PA4	In	LVTTTL	Image data I/O port A
30	PA5	In	LVTTTL	Image data I/O port A
31	PA6	In	LVTTTL	Image data I/O port A
32	PA7	In	LVTTTL	Image data I/O port A
33	PA8	In	LVTTTL	Image data I/O port A
34	PA9	In	LVTTTL	Image data I/O port A(MSB)
35	MA4	Out	2mA	SDRAM address output terminal
36	MA3	Out	2mA	SDRAM address output terminal
37	MA5	Out	2mA	SDRAM address output terminal
38	MA2	Out	2mA	SDRAM address output terminal
39	GND	P	-	Digital Ground
40	VDD3	P	-	VDD for IO (3.3V)

Pin No.	Name	I/O/P	Attribute	Functional Description
41	VDD2	P	-	VDD for Core (2.5V)
42	MA6	Out	2mA	SDRAM address output terminal
43	MA1	Out	2mA	SDRAM address output terminal
44	MA7	Out	2mA	SDRAM address output terminal
45	MA0	Out	2mA	SDRAM address output terminal(LSB)
46	MA8	Out	2mA	SDRAM address output terminal
47	MA10	Out	2mA	SDRAM address output terminal
48	VDD3	P	-	VDD for IO (3.3V)
49	MA9	Out	2mA	SDRAM address output terminal
50	MA11	Out	2mA	SDRAM address output terminal(MSB)
51	GND	P	-	Digital Ground
52	RAS	Out	2mA	SDRAM Row Address Strobe Command output terminal
53	MCLK	Out	4mA	SDRAM Clock output terminal (54MHz)
54	CAS	Out	2mA	SDRAM Column Address Strobe Command output terminal
55	WE	Out	2mA	SDRAM Write Enable output terminal
56	VDD3	P	-	VDD for IO (3.3V)
57	MD8	Inout	LVTTL, 2mA, Pullup	SDRAM data input-output terminal
58	MD7	Inout	LVTTL, 2mA, Pullup	SDRAM data input-output terminal
59	MD9	Inout	LVTTL, 2mA, Pullup	SDRAM data input-output terminal
60	PDOEN	In	LVTTL	Image port D input and output setting input terminal (L: input, H: output )
61	GND	P	-	Digital Ground
62	GND	P	-	Digital Ground
63	MD6	Inout	LVTTL, 2mA, Pullup	SDRAM data input-output terminal
64	MD10	Inout	LVTTL, 2mA, Pullup	SDRAM data input-output terminal
65	VDD3	P	-	VDD for IO (3.3V)
66	MD5	Inout	LVTTL, 2mA, Pullup	SDRAM data input-output terminal
67	MD11	Inout	LVTTL, 2mA, Pullup	SDRAM data input-output terminal
68	MD4	Inout	LVTTL, 2mA, Pullup	SDRAM data input-output terminal
69	MD12	Inout	LVTTL, 2mA, Pullup	SDRAM data input-output terminal
70	MD3	Inout	LVTTL, 2mA, Pullup	SDRAM data input-output terminal
71	MD13	Inout	LVTTL, 2mA, Pullup	SDRAM data input-output terminal
72	GND	P	-	Digital Ground
73	VDD3	P	-	VDD for IO (3.3V)
74	MD2	Inout	LVTTL, 2mA, Pullup	SDRAM data input-output terminal
75	MD14	Inout	LVTTL, 2mA, Pullup	SDRAM data input-output terminal
76	MD1	Inout	LVTTL, 2mA, Pullup	SDRAM data input-output terminal
77	MD15	Inout	LVTTL, 2mA, Pullup	SDRAM data input-output terminal
78	MD0	Inout	LVTTL, 2mA, Pullup	SDRAM data input-output terminal(LSB)
79	VDD2	P	-	VDD for Core (2.5V)
80	VDD3	P	-	VDD for IO (3.3V)
81	VDD3	P	-	VDD for IO (3.3V)
82	GND	P	-	Digital Ground
83	MD16	Inout	LVTTL, 2mA, Pullup	SDRAM data input-output terminal

Pin No.	Name	I/O/P	Attribute	Functional Description
84	MD17	Inout	LVTTTL, 2mA, Pullup	SDRAM data input-output terminal
85	MD18	Inout	LVTTTL, 2mA, Pullup	SDRAM data input-output terminal
86	MD19	Inout	LVTTTL, 2mA, Pullup	SDRAM data input-output terminal(MSB)
87	GND	P	-	Digital Ground
88	AGND	P	-	Ground for DAC
89	DAO_Y	Out	-	Analog video-out (Y)
90	AVDD2	P	-	VDD for DAC (2.5V)
91	DAO_Cb	Out	-	Analog video-out (Cb)
92	AGND	P	-	Ground for DAC
93	DAO_Cr	Out	-	Analog video-out (Cr)
94	AVDD2	P	-	VDD for DAC (2.5V)
95	VREF	In	-	DAC reference voltage input terminal
96	FSADJ	Inout	-	An ohms connection terminal for DAC peak swing setting
97	AVDD2	P	-	VDD for DAC (2.5V)
98	VG	Out	-	A volume connection terminal for gate voltage compensation of a DAC electric current cell
99	AGND	P	-	Ground for DAC
100	GND	P	-	Digital Ground
101	GND	P	-	Digital Ground
102	GND	P	-	Digital Ground
103	GND	P	-	Digital Ground
104	CLMP	Out	2mA	Clamp pulse output terminal
105	TEST0	In	LVTTTL	Test exclusive use input terminal
106	TEST1	In	LVTTTL	Test exclusive use input terminal
107	TEST2	In	LVTTTL	Test exclusive use input terminal
108	TEST3	In	LVTTTL	Test exclusive use input terminal
109	TEST4	In	LVTTTL	Test exclusive use input terminal
110	SPR0	Out	2mA	Serial-to-parallel conversion output terminal(LSB)
111	SPR1	Out	2mA	Serial-to-parallel conversion output terminal
112	VDD3	P	-	VDD for IO (3.3V)
113	SPR2	Out	2mA	Serial-to-parallel conversion output terminal
114	SPR3	Out	2mA	Serial-to-parallel conversion output terminal
115	SPR4	Out	2mA	Serial-to-parallel conversion output terminal
116	SPR5	Out	2mA	Serial-to-parallel conversion output terminal
117	GND	P	-	Digital Ground
118	SPR6	Out	2mA	Serial-to-parallel conversion output terminal
119	SPR7	Out	2mA	Serial-to-parallel conversion output terminal(MSB)
120	VDD3	P	-	VDD for IO (3.3V)
121	VDD2	P	-	VDD for Core (2.5V)
122	GND	P	-	Digital Ground
123	PB0	Inout	LVTTTL, leakage, 2mA	Image data I/O port B(LSB)
124	PB1	Inout	LVTTTL, leakage, 2mA	Image data I/O port B
125	PB2	Inout	LVTTTL, leakage, 2mA	Image data I/O port B
126	PB3	Inout	LVTTTL, leakage, 2mA	Image data I/O port B
127	VDD3	P	-	VDD for IO (3.3V)
128	PB4	Inout	LVTTTL, leakage, 2mA	Image data I/O port B

Pin No.	Name	I/O/P	Attribute	Functional Description
129	PB5	Inout	LVTTL, leakage, 2mA	Image data I/O port B
130	GND	P	-	Digital Ground
131	PB6	Inout	LVTTL, leakage, 2mA	Image data I/O port B
132	PB7	Inout	LVTTL, leakage, 2mA	Image data I/O port B
133	PB8	Inout	LVTTL, leakage, 2mA	Image data I/O port B
134	PB9	Inout	LVTTL, leakage, 2mA	Image data I/O port B(MSB)
135	PBOEN	In	LVTTL	Image port B input and output setting input terminal (L: input, H: output )
136	VDD3	P	-	VDD for IO (3.3V)
137	PC0	Out	2mA	Image data I/O port C(LSB)
138	PC1	Out	2mA	Image data I/O port C
139	PC2	Out	2mA	Image data I/O port C
140	PC3	Out	2mA	Image data I/O port C
141	GND	P	-	Digital Ground
142	GND	P	-	Digital Ground
143	PC4	Out	2mA	Image data I/O port C
144	PC5	Out	2mA	Image data I/O port C
145	VDD3	P	-	VDD for IO (3.3V)
146	PC6	Out	2mA	Image data I/O port C
147	PC7	Out	2mA	Image data I/O port C
148	PC8	Out	2mA	Image data I/O port C
149	PC9	Out	2mA	Image data I/O port C(MSB)
150	GND	P	-	Digital Ground
151	CSB	In	Schmitt	MPU Interface chip select input terminal
152	SDA	In	Schmitt	MPU Interface data entry terminal
153	SCL	In	Schmitt	MPU Interface clock input terminal
154	SRN	In	Schmitt	System reset input terminal
155	CKIPOL	In	LVTTL	System clock polarity setting input terminal
156	PLL_VDD	P	-	VDD of PLL exclusive use (2.5V)
157	CPOUT	Out	Analog	Analog output terminal from PLL charge pump
158	VCOIN	In	Analog	Analog input terminal from PLL outside charge account loop filter
159	PLL_GND	P	-	Ground of PLL exclusive use
160	VDD3	P	-	VDD for IO (3.3V)

No.	Pin Name	I/O	Pin Function
1	VSC	-	Ground terminal for core
2	XMSLAT	I	Latched input terminal for microcomputer serial communication
3	MSCK		Shift clock input terminal for microcomputer serial communication
4	MSDAI		Data entry terminal for microcomputer serial communication
5	VDC	-	Power supply terminal for core
6	MSDATO	O	Data output terminal for microcomputer serial communication
7	MSREADY		Output preparation completion flag for microcomputer serial communication
8	XMSDOE		Output enable terminal for microcomputer serial communication
9	XRST	I	Reset terminal resets the whole IC with "L".
10	SMUTE	lpu	Software mute removes audio out with "L" with "H" a soft mute terminal.
11	MCKI	I	Master clock input terminal
12	VSIO	-	Ground terminal for I/O
13	EXCKO1	O	Outside output clock terminal 1
14	EXCKO2		Outside output clock terminal 2
15	LRCK		1Fs (44.1kHz) clock output terminal
16	FRAME		Frame signal output terminal
17	VDIO	-	Power supply terminal for I/O
18	MNT0	O	Monitor output terminal
19	MNT1		
20	MNT2		
21	MNT3		Output terminal for test
22	TESTO		
23			
24			
25			
26	TCK	I	It is fixation in "L" a clock input terminal for test.
27	TDI	lpu	Input terminal for test
28	VSC	-	Ground terminal for core
29	TDO	O	Output terminal for test
30	TMS	lpu	Input terminal for test
31	TRST		Reset terminal for test
32	TEST1	I	It is fixation in "L" a clock input terminal for test.
33	TEST2		
34	TEST3		
35	VDC	-	Power supply terminal for core
36	TESTO	O	Output terminal for test
37	XBIT		DST connection monitor terminal
38	SUPDT0		Supplementary data output terminal (LSB)
39	SUPDT1		Supplementary data output terminal
40	SUPDT2		
41	SUPDT3		
42	VSIO	-	Ground terminal for I/O
43	SUPDT4	O	Supplementary data output terminal
44	SUPDT5		
45	VDIO	-	Power supply terminal for I/O
46	SUPDT6	O	Supplementary data output terminal
47	SUPDT7		Supplementary data output terminal (MSB)
48	XSUPAK		Supplementary data output terminal
49	VSC	-	Ground terminal for core
50	TESTO	O	Output terminal for test

No.	Pin Name	I/O	Pin Function
51	TESTI	I	It is fixation in "L" a test input terminal.
52			
53	TESTO	O	Output terminal for test
54	VDC	-	Power supply terminal for core
55	DSADML	O	DSD data output terminal for Lch Down Mix
56	DSADMR		DSD data output terminal for Rch Down Mix
57	BCKASL	I	Input and output choice terminal of a 1 bit clock for DSD data output.L= input (slave), H = output (master).
58	VSDSD	-	Ground terminal for DSD data output
59	BCKAI	I	Bit clock input terminal for DSD data output
60	BCKAO	O	Bit clock output terminal for DSD data output
61	PHREFI	I	Phase reference signal input terminal for DSD output phase modulation
62	PHREFO	O	Phase reference signal output terminal for DSD output phase modulation
63	ZDFL		Zero Lch data search flag
64	DSAL		DSD data output terminal for Lch loud speaker
65	ZDFR		Zero Rch data search flag
66	DSAR	O	DSD data output terminal for Rch loud speaker
67	VDDSD		-
68	ZDFC	O	Zero Cch data search flag
69	DSAC		DSD data output terminal for Cch loud speaker
70	ZDFLFE		Zero LFEch data search flag
71	DSASW		DSD data output terminal for SWch loud speaker
72	VSDSD	-	Ground terminal for DSD data output
73	ZDFLS	O	Zero LSch data search flag
74	DSALS		DSD data output terminal child for LSch loud speaker
75	ZDFRS		Zero RSch data search flag
76	DSARS		DSD data output terminal for RSch loud speaker
77	VDDSD	-	Power supply Mizuko for DSD data output
78	IOU0	O	Data output terminal 0 for IEEE1394 link tip I/F
79	IOU1		Data output terminal 1 for IEEE1394 link tip I/F
80	VSC	-	Ground terminal for core
81	IOU2	O	Data output terminal 2 for IEEE1394 link tip I/F
82	IOU3		Data output terminal 3 for IEEE1394 link tip I/F
83	VDC	-	Power supply terminal for co
84	IOU4	O	Data output terminal 4 for IEEE1394 link tip I/F
85	IOU5		Data output terminal 5 for IEEE1394 link tip I/F
86	VSIO	-	Ground terminal for I/O
87	IANCO	O	Transmission information data output terminal for IEEE1394 link tip I/F
88	IFULL	I	Data transmission hold demand signal input terminal for IEEE1394 link tip I/F
89	IEMPTY		High speed transmission demand signal input terminal for IEEE1394 link tip I/F
90	VDIO	-	Power supply terminal for I/O
91	IFRM	O	Frame reference signal output Mizuko for IEEE1394 link tip I/F
92	IOUTE		Enable signal output terminal for IEEE1394 link tip I/F
93	IBCK		Data transmission clock output terminal for IEEE1394 link tip I/F
94	VSC	-	Ground terminal for core
95	TESTI	I	It is fixation in "H" a test input terminal.
96			It is fixation in "L" a test input terminal.
97		Ipu	It is fixation in "H" a test input terminal.
98	TESTO	O	Output terminal for test
99	VDC	-	Power supply terminal for co
100	TESTI	I	It is fixation in "L" a test input terminal.

No.	Pin Name	I/O	Pin Function
101	TESTI	I	It is fixation in "L" a test input terminal.
102			
103			
104			
105			
106	VSIO	-	Ground terminal for I/O
107	TESTI	I	It is fixation in "L" a test input terminal.
108			
109			
110	VDIO	-	Power supply terminal for I/O
111	WAD0	I	Outside A/D data entry terminal for PSP Physical Disc Mark search (LSB)
112	WAD1		Outside A/D data entry terminal for PSP Physical Disc Mark search
113	WAD2		
114	WAD3		
115	VSIO		
116	VSC	-	Ground terminal for core
117	WAD4	I	Outside A/D data entry terminal for PSP Physical Disc Mark search
118	WAD5		
119	WAD6		
120	WAD7		Outside A/D data entry terminal for PSP Physical Disc Mark search (MSB)
121	VDC	-	Power supply terminal for core
122	TESTI	I	It is fixation in "L" a test input terminal.
123	WCK		Movement clock for PSP Physical Disc Mark search
124	WAVDD	-	A/D power supply terminal for PSP Physical Disc Mark search
125			
126	WARFI	Ai	Analog RF signal input terminal for PSP Physical Disc Mark search
127	WAVRB		A/D bottom reference terminal for PSP Physical Disc Mark search
128	WAVSS	-	A/D ground terminal for PSP Physical Disc Mark search
129			
130	VSIO	-	Ground terminal for I/O
131	DQ7	I/O	SDRAM data input-output terminal (MSB)
132	DQ6		SDRAM data input-output terminal
133	DQ5		
134	DQ4		
135	VDIO	-	Power supply terminal for I/O
136	DQ3	I/O	SDRAM data input-output terminal
137	DQ2		
138	DQ1		
139	DQ0		SDRAM data input-output terminal (LSB)
140	VSIO	-	Ground terminal for I/O
141	DCLK	O	Clock output terminal for SDRAM
142	DCKE		Clock enable output terminal for SDRAM
143	XWE		Wright enable output terminal for SDRAM
144	XCAS		Column address strobe output terminal for SDRAM
145	XRAS		Row address strobe output terminal for SDRAM
146	VDIO		-
147	TESTO	O	Output terminal for test
148	A11		Address output terminal for SDRAM (MSB)
149	A10		Address output terminal for SDRAM
150	VSC	-	Ground terminal for core

No.	Pin Name	I/O	Pin Function
151	A9	O	Address output terminal for SDRAM
152	A8		
153	VDC	-	Power supply terminal for core
154	A7	O	Address output terminal for SDRAM
155	A6		
156	A5		
157	A4		
158	VSIO	-	Ground terminal for I/O
159	A3	O	Address output terminal for SDRAM
160	A2		
161	A1		
162	A0		Address output terminal for SDRAM (LSB)
163	VDIO	-	Power supply terminal for I/O
164	XSRQ	O	Data request output terminal to input into a front end processor
165	XSHD	I	Input terminal of a header flag output by a front end processor
166	SDCK		Input terminal of a data carrier clock output by a front end processor
167	XSAK		Input terminal of data partial response flag output by a front end processor
168	SDEF		Input terminal of error flag output by a front end processor
169	SD0		The stream data input terminal which is output by a front end processor (LSB)
170	SD1		The stream data input terminal which is output by a front end processor
171	SD2		
172	SD3		
173	SD4		
174	SD5	The stream data input terminal which is output by a front end processor (MSB)	
175	SD6		
176	SD7		

Ipu : Pull-up input, Ipd : Pull-down input, Ai : Analog input



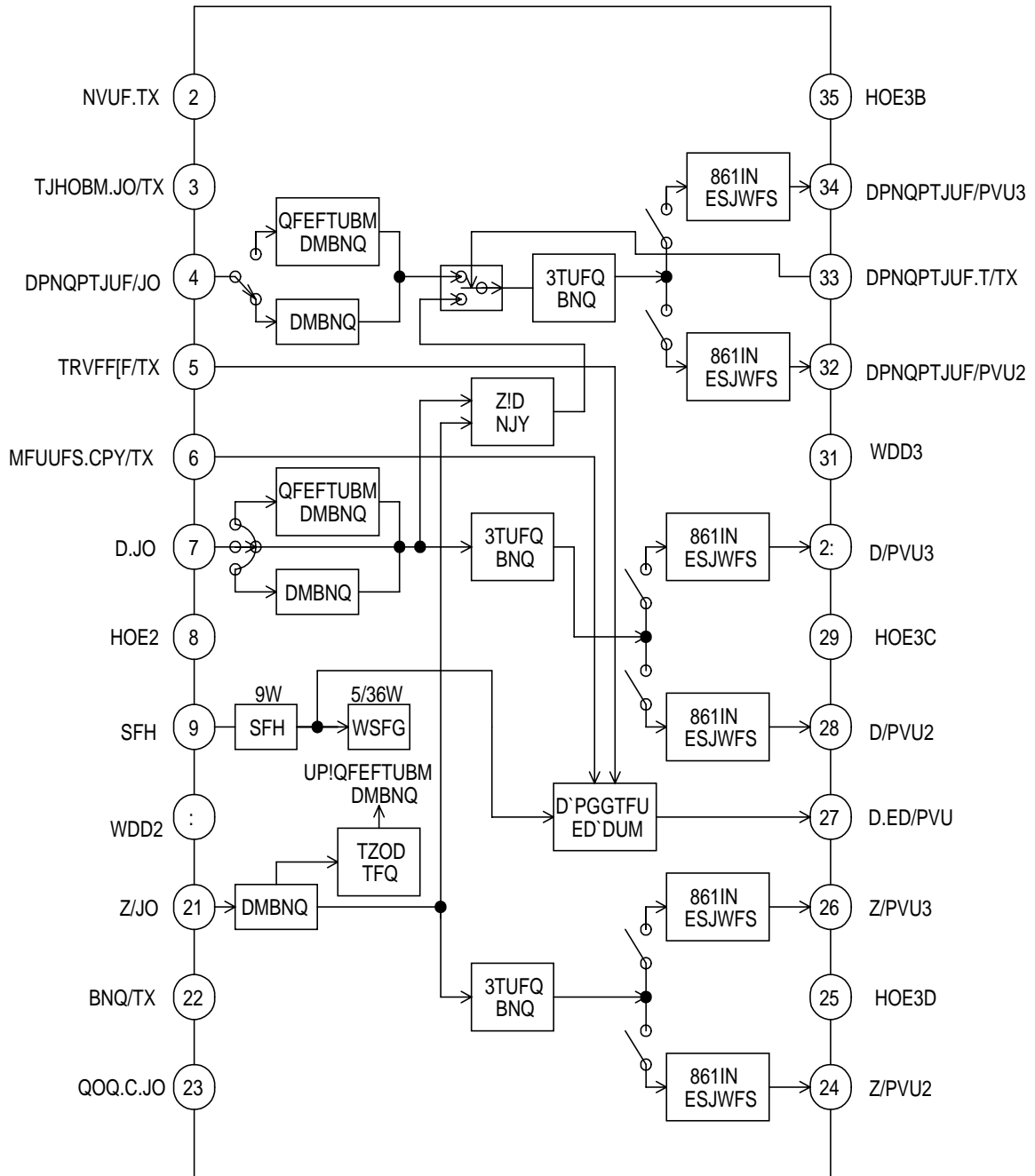

入出力形態図 / Input/output form diagram 記号の単位 抵抗/Resistance :  $\Omega$

Pin No.	名称 Pin Name	I/O	端子 電圧	入出力 インピーダンス	等価回路 Equivalent Circuit	端子説明 Terminal Explanation
1	MUTE-SW	I	1.7V	21k $\Omega$		映像信号出力 (13, 17, 21/15, 19, 23pin)のミュート 制御端子です。 3.3~5.0V電源のマイコンでコント ロールが可能です。 Mute control pin for video signal outputs (13, 17, 21/15, 19, 23pin). Control can be made with a microcomputer operating on 3.3~ 5.0 V power supply.
2	SIGNAL- IN-SW	I	1.7V	21k $\Omega$		入力信号の種類(コンポジット・S/ コンポーネント/ベースバンド)に合 せて、3ピン及び6ピンの入力形態 を切替える端子です。 3.3~5.0V電源のマイコンでコント ロールが可能です。 外付けに“5.1k $\Omega$ ”の抵抗をシリス ズに付加して下さい。 Pin to select the input form of pins 3 and 6 according to the type of input signal (composite/s /component/ base band). Control can be made with a microcomputer operating on 3.3~5.0 V power supply. Add a 5.1k $\Omega$ resistor in series externally.
3	COMPOSITE -IN	I	4.5V	Clamp form		映像信号入力端子です。 コンポジット/S信号入力時にはコン ポジット信号を、コンポーネント 信号入力時にはB-Y又はR-Y信号を入 力して下さい。 ベースバンド入力時には、同期信号 のあるRGB信号のどれかを入力し て下さい。(S信号入力時は、このピ ンはGNDに落ちます。) Video signal input pin. Enter the composite signal for input of the composite/S signal. Enter the B-Y or R-Y signal for input of the component signal. For input of the base band, enter any of RGB signals that have a sync signal. (This pin is connected to GND when the S signal is entered.)

記号の単位 抵抗/Resistance :  $\Omega$

Pin No.	名称 Pin Name	I/O	端子 電圧	入出力 インピーダンス	等価回路 Equivalent Circuit	端子説明 Terminal Explanation
4	SQUEEZE- SW	I	2.4V	9.0G $\Omega$		スクイーズ情報を入力する端子です。 3.3~5.0V電源のマイコンでコント ロールが可能です。 Pin to enter the squeeze information. Control can be made with a microcomputer that operates on 3.3~5.0 V power supply.
5	LETTER- BOX-SW	I	2.43V	8.1G $\Omega$		レターボックス情報を入力する端子 です。 3.3~5.0V電源のマイコンでコント ロールが可能です。 Pin to enter the letter box information. Control can be made with a microcomputer that operates on 3.3 ~5.0 V power supply.
6	C-IN	I	4.8V	10k $\Omega$		映像信号入力端子です。 コンポジット/S信号入力時にはクロ マ信号を入力して下さい。コンポ ネント信号入力時にはB-Y又はR-Y 信号を入力して下さい。 ベースバンド信号入力時には、同期 信号のあるRGB信号のどれかを入 力して下さい。 Video signal input pin. Enter the chroma signal for input of composite/S signal. Enter the B-Y or R-Y signal for input of the component signal input. For input of the base band signal, enter any of RGB signals that have a sync signal.
7	GND1	P	0V			信号処理回路用のGNDです。 GND for the signal processing circuit.

記号の単位 抵抗/Resistance :  $\Omega$

Pin No.	名称 Pin Name	I/O	端子 電圧	入出力 インピーダンス	等価回路 Equivalent Circuit	端子説明 Terminal Explanation
8	REG	0	8V			IC内の8V電源電圧を作るレギュレ ータ用の端子です。 電源電圧1.2Vで使用する際には、外 付けPNPトランジスタのコレクタを接 続して下さい(TEST CURCUIT A参照)。 「IC内のノイズはレギュレータの安定 度に左右されるので、Y/C-MIX以外でS/N を-80dB確保したい場合は、470 $\mu$ Fのコン デンサを付ける事を推奨します。 Y/C-MIX時にS/Nを-74dB確保したい場合 は、電源電圧を8V(VCCB)で使用し、当 ピンにも8Vを加えて下さい(TEST CURCUIT B参照)。 Pin for the regulator that generates an 8 V supply voltage in IC. To use the supply voltage of 1.2 V, connect a collector of the external PNP transistor (see the test circuit A). Since the noise in IC is dependent on the stability of regulator, it is recommended to connect a 470 $\mu$ F capacitor when the S/N ratio of -80 dB is to be secured for controls other than Y/C-MIX. To secure the S/N ratio of -74 dB for Y/C-MIX, set the supply voltage to 8 V (VCCB) and apply 8 V also to this pin. (See the test circuit B.)
9	VCC1	P	12V OR 8.0V			信号処理回路用のVCCです。 電源電圧を12Vで使用する際には、外 付けPNPトランジスタのエミッタ を接続して下さい(TEST CURCUIT A参 照)。7ピンとの間に47 $\mu$ F程度のコン デンサを入れて下さい。 VCC for a signal processing circuit. To use the supply voltage of 12 V, connect an emitter of external PNP transistor (see the test circuit A). Insert a capacitor of around 47 $\mu$ F between this VCC and pin 7.

記号の単位 抵抗/Resistance :  $\Omega$

Pin No.	名称 Pin Name	I/O	端子 電圧	入出力 インピーダンス	等価回路 Equivalent Circuit	端子説明 Terminal Explanation
10	Y-IN	I	4.2V	Clamp form		映像信号入力端子です。 コンポジット/S及びコンポーネ ント信号入力時にはY信号を、ベー スバンド信号入力時には同期信号の あるRGB信号のどれかを入力して下 さい。 Video signal input pin. Enter the Y signal for input of composite/S and component signal. For input of the base band signal, enter any of RGB signals that have a sync signal.
11	AMP-SW	I	2.4V	9.0G $\Omega$		入力信号の振幅に合わせてAMPゲ インを切替える制御端子です。 3.3~5.0V電源のマイコンでも、基板 上でのVCC/GND切替えてもコント ロールが可能です。 Control pin to select the AMP gain according to the input signal amplitude. Control is possible with a microcomputer that operates on 3.3 ~5.0 V power supply as well as through selection of VCC/GND on a substrate.
12	PNP-B-IN	0	3.4V	4.0G $\Omega$		8Vレギュレータ用外付けPNPトラン ジスタのベース入力端子です。 電源電圧12V時にはトランジスタに接 続して下さい(TEST CURCUIT A参照)。 電源電圧を8Vで使用する際にはオー ープンにして下さい(TEST CURCUIT B参 照)。ベース入力ピンは外部PNP トランジスタのベースに接続しな がら、電源電圧を8Vに保ち、この ピンをオープンにしてください(参 照)。 To use the supply voltage of 12 V, connect to the transistor in case of the supply voltage of 12 V (see the test circuit A). To use the supply voltage of 8 V, keep this pin open (see the test circuit B).
13	Y,OUT1	0	2.7V	11.6 $\Omega$		映像信号出力端子です。 10ピンに入力された映像信号を7 5 $\Omega$ でドライブします。ミュート機 能あり。 Video signal output pin. Drives the video signal entered in pin 10 by 75 $\Omega$ . Mute function available.

Pin No.	名称 Pin Name	I/O	端子 電圧	入出力 インピーダンス	等価回路 Equivalent Circuit	端子説明 Terminal Explanation
14	GND2	P	0V		7	5Ωドライブ回路(13ピン及び15ピン)のGNDです。出力信号の振幅が大きいため、レイアウトには十分注意して下さい。 GND of the 7.5Ω drive circuit (pins 13 and 15). Pay due attention on the layout because the output signal has a substantial amplitude.
15	Y.OUT2	O	2.7V	11.6Ω		映像信号出力端子です。 10ピンに入力された映像信号を7.5Ωでドライブします。ミュート機能あり。 Video signal output pin. Drives the video signal entered in pin 10 by 7.5Ω. The mute function available.
16	G-DC.OUT	O	4.7V	4.1Ω		S1/S2用DC電圧出力端子です。 4:3モード時には0Vを、レターボックス時には2.2Vを、スクイーズモード時には5Vを出力します。 クロマ信号出力を容量結合した後に10kΩの抵抗で接続して下さい。 S1/S2 DC voltage output pin. Outputs 0V for the 4:3 mode, 2.2V for the letter box mode, and 5V for the squeeze mode. Connect with a 10kΩ resistor after capacitive coupling of chroma signal output.
17	C.OUT1	O	3.9V	11.6Ω		映像信号出力端子です。 6ピンに入力された映像信号を7.5Ωでドライブします。1ピンによりミュート可能です。 Video signal output pin. Drives the video signal entered in pin 6 by 7.5Ω. Mute possible with pin 1.

Pin No.	名称 Pin Name	I/O	端子 電圧	入出力 インピーダンス	等価回路 Equivalent Circuit	端子説明 Terminal Explanation
18	GND2B	P	0V		7	5Ωドライブ回路(17ピン及び19ピン)のGNDです。出力信号の振幅が大きいため、レイアウトには十分注意して下さい。 GND of the 7.5Ω drive circuit (pins 17 and 19). Pay due attention on the layout because the output signal has a substantial amplitude.
19	C.OUT2	O	3.9V	11.6Ω		映像信号出力端子です。 6ピンに入力された映像信号を7.5Ωでドライブします。1ピンでミュート可能です。 Video signal output pin. Drives the video signal entered in Pin 6 by 7.5Ω. Mute possible with pin 1.
20	VCC2	P	8V			7.5Ωドライブ回路用のVCCです。 7.5Ωドライブ回路のGNDとの間に47μF程度のコンデンサを入れて下さい。 出力信号の振幅が大きいため、レイアウトには十分注意して下さい。 VCC for the 7.5Ω drive circuit. Insert a capacitor of around 47μF between this VCC and GND of the 7.5Ω drive circuit. Pay due attention to the layout because the output signal has a substantial amplitude.
21	COMPOSITE. OUT1	O	3.57V	11.6Ω		映像信号出力端子です。 3ピンに入力された映像信号を7.5Ωでドライブします。 1ピンでミュート可能です。 Video signal output pin. Video signal entered in pin 3 is driven by 7.5Ω. Mute possible with pin 1.

Pin No.	名称 Pin Name	I/O	端子 電圧	入出力 インピーダンス	等価回路 Equivalent Circuit	端子説明 Terminal Explanation
18	GND2B	P	0V		7	5Ωドライブ回路(17ピン及び19ピン)のGNDです。出力信号の振幅が大きいため、レイアウトには十分注意して下さい。 GND of the 7.5Ω drive circuit (pins 17 and 19). Pay due attention on the layout because the output signal has a substantial amplitude.
19	C.OUT2	O	3.9V	11.6Ω		映像信号出力端子です。 6ピンに入力された映像信号を7.5Ωでドライブします。1ピンでミュート可能です。 Video signal output pin. Drives the video signal entered in Pin 6 by 7.5Ω. Mute possible with pin 1.
20	VCC2	P	8V			7.5Ωドライブ回路用のVCCです。 7.5Ωドライブ回路のGNDとの間に47μF程度のコンデンサを入れて下さい。 出力信号の振幅が大きいため、レイアウトには十分注意して下さい。 VCC for the 7.5Ω drive circuit. Insert a capacitor of around 47μF between this VCC and GND of the 7.5Ω drive circuit. Pay due attention to the layout because the output signal has a substantial amplitude.
21	COMPOSITE. OUT1	O	3.57V	11.6Ω		映像信号出力端子です。 3ピンに入力された映像信号を7.5Ωでドライブします。 1ピンでミュート可能です。 Video signal output pin. Video signal entered in pin 3 is driven by 7.5Ω. Mute possible with pin 1.

Pin No.	名称 Pin Name	I/O	端子 電圧	入出力 インピーダンス	等価回路 Equivalent Circuit	端子説明 Terminal Explanation
22	COMPOSITE -S.SW	I	2.4V	9.06Ω		Y/C-MIX ON/OFFを制御する端子です。 2ピンの制御がコンポジット/S時以外の場合は、必ずこのピンはHighにしてください。 3.3~5.0V電源のマイコンでも、基板上でのVCC/GND切替でも制御可能です。 Y/C-MIX ON/OFF control pin. Be sure to set this pin HIGH in cases other than composite/S control of pin 2. Control is possible with a microcomputer operating on 3.3~5.0V power supply or through selection of VCC/GND on the substrate.
23	COMPOSITE. OUT2	O	3.57V	11.6Ω		映像信号出力端子です。 3ピンに入力された映像信号を7.5Ωでドライブします。 1ピンでミュート可能です。 Video signal output pin. Drives the video signal entered in pin 3 by 7.5Ω. Mute possible with pin 1.
24	GND2A	P	0V			7.5Ωドライブ回路(21ピン及び23ピン)のGNDです。 出力信号の振幅が大きいため、レイアウトには十分注意して下さい。 GND of the 7.5Ω drive circuit (pins 21 and 23). Pay due attention on the layout because the output signal has a substantial amplitude.

### Q859 : MM1506XNRE

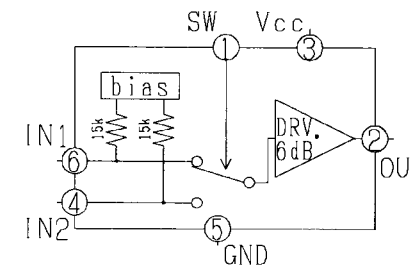

#### 制御入力真理値表

#### Truth table

SW	OUT
L	IN1
H	IN2

### Q860 : MM1508XNRE

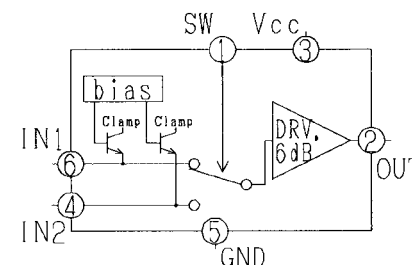

#### 制御入力真理値表

#### Truth table

SW	OUT
L	IN1
H	IN2

### Q853/Q856/Q861 : MM1509XNRE

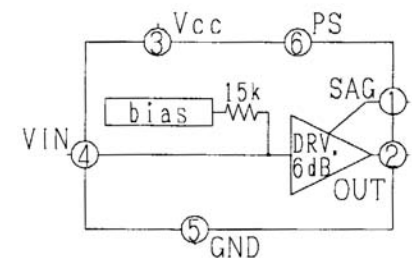

PS端子 PS-Pin	パワーセーブ Power-save
L	ON
H	OFF

### 13. EXPLODED VIEW AND PARTS LIST

SYMBOL	STYLE	PARTS NAME
5110		+B. H. M. SCREW
5125		+B. H. TAP TITE SCREW(P TYPE)
5126		+B. H. TAP TITE SCREW W/WASHER
5127		+P. H. TAP TITE SCREW(B TYPE)
5128		+B. H. TAP TITE SCREW(B TYPE)
5129		+B. H. TAP TITE SCREW(W/T. L. WASHER)
5192		+P. H. M. SCREW(MINUTE)

MARK	MATERIAL/FINISH
(M)	STEEL/ COPPER
(U)	STEEL/ BLACK

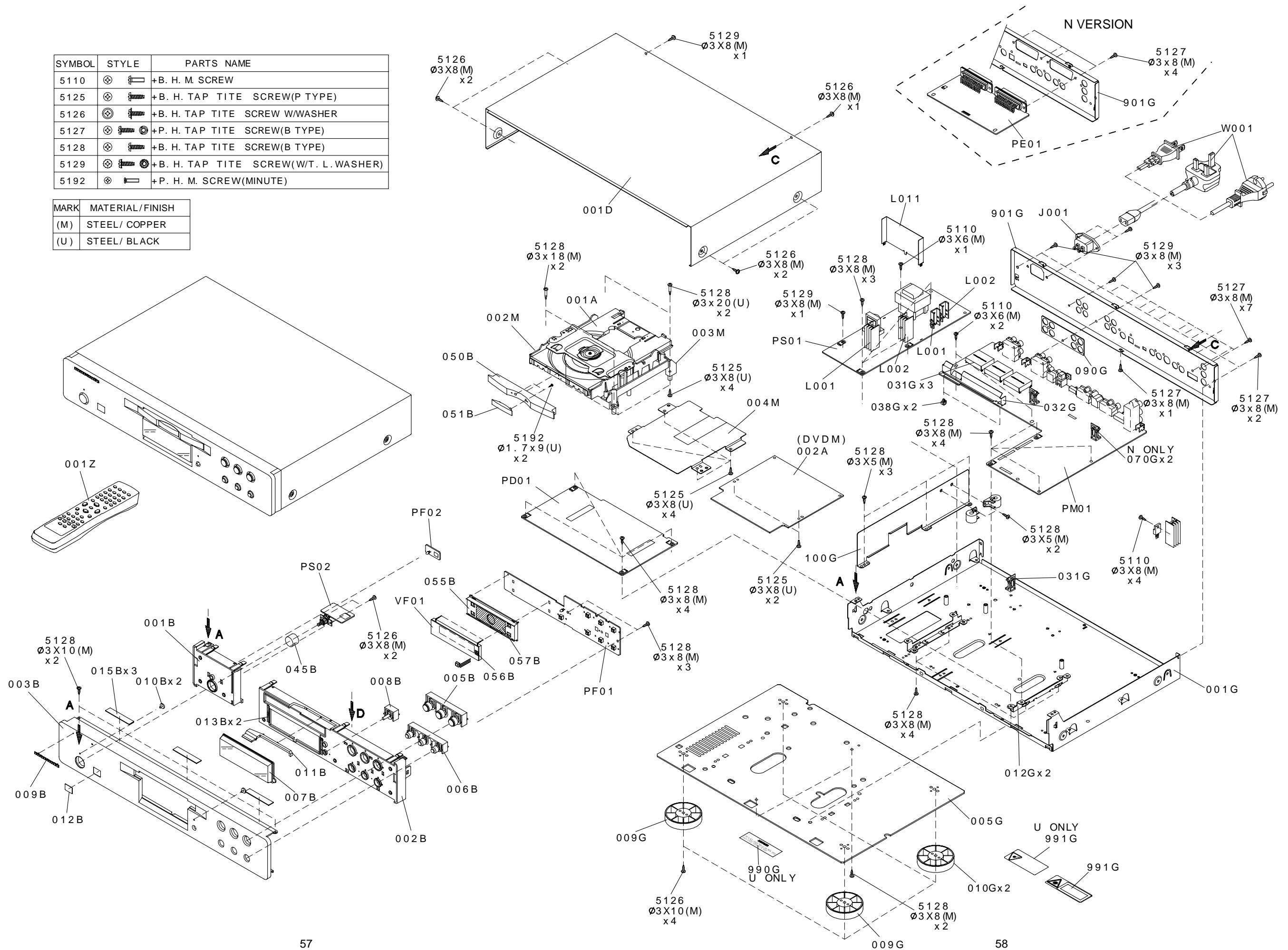

POS. NO	VERS. COLOR	PART NO. (FOR EUR)	DESCRIPTION	PART NO. (MJI)	POS. NO	VERS. COLOR	PART NO. (FOR EUR)	DESCRIPTION	PART NO. (MJI)
001A		02AK304500	MECHANISM DVD LOADER DB-VLD302	02AK304500				<b>PACKING</b>	
002A		ZK02AK0210	UNIT KIT DB-VPB305	ZK02AK0210	001T	/A/C/L		USER GUIDE	02AK851350
001B	GOLD	02AK105120	FRONT CHASSIS PL L	02AK105120	001T	/F		USER GUIDE	02AK851110
001B	BLACK	02AK105020	FRONT CHASSIS PL L	02AK105020	001T	/N	02AK851310	USER GUIDE	02AK851310
002B	GOLD	02AK105130	FRONT CHASSIS PL R	02AK105130	001T	/U		USER GUIDE	02AK851250
002B	BLACK	02AK105030	FRONT CHASSIS PL R	02AK105030	005T	/N	02AK851320	USER GUIDE	02AK851320
003B	GOLD	02AK248110	FRONT PANEL AL	02AK248110	001Z		ZK02AK0010	REMOTE CONTROLLER	ZK02AK0010
003B	BLACK	02AK248010	FRONT PANEL AL	02AK248010					
005B	GOLD	02AK270110	BUTTON FUNCTION	02AK270110	▲ W001	/C		MAINS CORD SET 7A 250V KOREAN	ZC02009010
005B	BLACK	02AK270010	BUTTON FUNCTION	02AK270010					
006B	GOLD	02AK270120	BUTTON SUB FUNC	02AK270120	▲ W001	/F		MAINS CORD MITY 125V 12A	ZC01802080
006B	BLACK	02AK270020	BUTTON SUB FUNC	02AK270020	▲ W001	/L		MAINS CORD UL/CSA 10A 125V	ZC01803100
007B		02AK158010	WINDOW	02AK158010					
008B		02AK270030	BUTTON FL OFF	02AK270030	▲ W001	/N	ZC01803080	MAINS CORD 2P 10A 250V CLASS2	ZC01803080
009B		nsp	BADGE MARANTZ BL	185J251010					
010B		230K355030	LENS STANDBY/FL OFF	230K355030	▲ W001	/S		MAINS CORD 250V 10A	ZC01804100
011B		02AK355010	LENS TRAY UPPER	02AK355010	▲ W001	/A		MAINS CORD 250V 10A TESCOM	ZC02006050
012B	/C/F/L	02AK251010	BADGE SACD GOLD	02AK251010					
	/N								
012B	/U		BADGE SACD	02AK251020					
045B	GOLD	02AK270140	BUTTON POWER GOLD	02AK270140					
045B	BLACK	02AK270040	BUTTON POWER BLACK	02AK270040					
050B	GOLD	02AK063110	ESCUTCHEON TRAY FRONT	02AK063110					
050B	BLACK	02AK063010	ESCUTCHEON TRAY FRONT	02AK063010					
051B		392K063160	ESCUTCHEON SACD	392K063160					
009G		383K057010	LEG PORON GOLD HOT STAMP F	383K057010					
010G		383K057110	LEG PORON GOLD HOT STAMP R	383K057110					
		02AK362010	ADAPTOR MECHA L	02AK362010					
002M		02AK362020	ADAPTOR MECHA R	02AK362020					
003M		02AK271110	HOLDER MECHA	02AK271110					
004M									
▲ J001		YJ04002550	JACK AC INLET TYPE HF-301	YJ04002550					
L007		FC50160030	FERRITE CORE TFCK-16-8-13	FC50160030					
L008		FC50230010	FERRITE CORE	FC50230010					
L009		FC90400010	FERRITE CORE SSC-40-12	FC90400010					
L010		FC50160030	FERRITE CORE TFCK-16-8-13	FC50160030					
WD01		nsp	JUMPER LEAD PD01-DIGITAL BOARD	YU40042510					
WD02		nsp	JUMPER LEAD PD01-PM01-A	YU30055520					
WD03		nsp	JUMPER LEAD PD01-PM01-B	YU30055520					
WD04		nsp	JUMPER LEAD PD01-PM01-C	YU30055520					
WE01	/N	nsp	JUMPER LEAD PM01-PE01	YU12080520					
WF01		nsp	JUMPER LEAD PM01-PF01	YU20155520					
WP03		nsp	JUMPER LEAD PS01-PD01	YU30055520					
								<b>NOT STANDARD SPARE PARTS</b>	
					001S			PACKING CASE	02AK801010
					002S			CUSHION	386K809010
					003Z			CONNECTIVE CORD 3PIN RCA VIDEO&L/R 1.5M	ZD01500410
					004Z			CONNECTIVE CORD RCA RC-5 CORD 0.9M	ZD00900100

NOTE : "nsp" PART IS LISTED FOR REFERENCE ONLY, MARANTZ WILL NOT SUPPLY THESE PARTS.

# 14. ELECTRICAL PARTS LIST

## ASSIGNMENT OF COMMON PARTS CODES.

### RESISTORS

R\*\*\*: 1) GD05xxx140, Carbon film fixed resistor, ±5% 1/4W  
 R\*\*\*: 2) GD05xxx160, Carbon film fixed resistor, ±5% 1/6W

① Resistance value

Examples ;

- ① Resistance value
- 0.1 Ω .... 001    10 Ω .... 100    1 kΩ .... 102    100 kΩ .... 104
- 0.5 Ω .... 005    18 Ω .... 180    2.7 kΩ .... 272    680 kΩ .... 684
- 1 Ω .... 010    100 Ω .... 101    10 kΩ .... 103    1 MΩ .... 105
- 6.8 Ω .... 068    390 Ω .... 391    22 kΩ .... 223    4.7 MΩ .... 475

**Note :** Please distinguish 1/4W from 1/6W by the shape of parts used actually.

### CAPACITORS

C\*\*\*: CERAMIC CAP.

3) DD1xxx370, Ceramic capacitor  
 Disc type  
 Temp.coeff.P350 ~ N1000, 50V

② Capacity value  
 Tolerance

Examples ;

- ② Tolerance (Capacity deviation)
- ±0.25 pF .... 0
- ±0.5 pF .... 1
- ±5% .... 5

\* Tolerance of COMMON PARTS handled here are as follows :

- 0.5 pF ~ 5 pF .... ±0.25 pF
- 6 pF ~ 10 pF .... ±0.5 pF
- 12 pF ~ 560 pF .... ±5%

③ Capacity value

- 0.5 pF .... 005    3 pF .... 030    100 pF .... 101
- 1 pF .... 010    10 pF .... 100    220 pF .... 221
- 1.5 pF .... 015    47 pF .... 470    560 pF .... 561

C\*\*\*: CERAMIC CAP.

4) DK16xxx300, High dielectric constant ceramic capacitor  
 Disc type  
 Temp.chara. 2B4, 50V

④ Capacity value

Examples ;

- ④ Capacity value
- 100 pF .... 101    1000 pF .... 102    10000 pF .... 103
- 470 pF .... 471    2200 pF .... 222

C\*\*\*: 5) ELECTROLY CAP. (  $\text{⏏}$  ), 6) FILM CAP. (  $\text{⏏}$  )

5) EAxxx10, Electrolytic capacitor  
 One-way lead type, Tolerance ±20%

⑤ Capacity value  
 Working voltage

Examples ;

- ⑤ Capacity value
- 0.1 μF .... 104    4.7 μF .... 475    100 μF .... 107
- 0.33 μF .... 334    10 μF .... 106    330 μF .... 337
- 1 μF .... 105    22 μF .... 226    1100 μF .... 118
- 2200 μF .... 228
- ⑥ Working voltage
- 6.3V .... 006    25V .... 025
- 10V .... 010    35V .... 035
- 16V .... 016    50V .... 050

6) DF15xxx350 → Plastic film capacitor  
 DF15xxx310 → One-way type, Mylar ±5% 50V  
 DF16xxx310 → Plastic film capacitor  
 DF16xxx310 → One-way type, Mylar ±10% 50V

⑦ Capacity value

Examples ;

- ⑦ Capacity value
- 0.001 μF (1000 pF) ..... 102    0.1 μF .... 104
- 0.0018 μF ..... 182    0.56 μF .... 564
- 0.01 μF ..... 103    1 μF .... 105
- 0.015 μF ..... 153

**NOTE :** 1) The above CODES ( R\*\*\* , R\*\*\* , C\*\*\* , C\*\*\* and C\*\*\* ) are omitted on the schematic diagram in some case.

- 2) On the occasion, be confirmed the common parts on the parts list.
- 3) Refer to "Common Parts List" for the other common parts (R105, DD4, DK4).

## NOTE ON SAFETY FOR FUSIBLE RESISTOR :

The suppliers and their type numbers of fusible resistors are as follows;

1. KOA Corporation

Part No. (MJI)	Type No. (KOA)	Description
NH05 xxx 140	RF25S xxx ΩJ	(±5% 1/4W)
NH05 xxx 120	RF50S xxx ΩJ	(±5% 1/2W)
NH85 xxx 110	RF73B2A xxx ΩJ	(±5% 1/10W)
NH95 xxx 140	RF73B2E xxx ΩJ	(±5% 1/4W)

\* Resistance value      Resistance value  
 (0.1 Ω – 10 kΩ)

2. Matsushita Electronic Components Co., Ltd

Part No. (MJI)	Type No. (MEC)	Description
NF05 xxx 140	ERD-2FCJ xxx	(±5% 1/4W)
RF05 xxx 140		
NF02 xxx 140	ERD-2FCG xxx	(±2% 1/4W)
RF02 xxx 140		

\* Resistance value      \* Resistance value

Examples ;

- \* Resistance value
- 0.1 Ω .... 001    10 Ω .... 100    1 kΩ .... 102    100 kΩ .... 104
- 0.5 Ω .... 005    18 Ω .... 180    2.7 kΩ .... 272    680 kΩ .... 684
- 1 Ω .... 010    100 Ω .... 101    10 kΩ .... 103    1 MΩ .... 105
- 6.8 Ω .... 068    390 Ω .... 391    22 kΩ .... 223    4.7 MΩ .... 475

## ABBREVIATION AND MARKS

ANT. : ANTENNA	BATT. : BATTERY
CAP. : CAPACITOR	CER. : CERAMIC
CONN. : CONNECTING	DIG. : DIGITAL
HP. : HEADPHONE	MIC. : MICROPHONE
μ-PRO : MICROPROCESSOR	REC. : RECORDING
RES. : RESISTOR	SPK : SPEAKER
SW. : SWITCH	TRANSF. : TRANSFORMER
TRIM. : TRIMMING	TRS. : TRANSISTOR
VAR. : VARIABLE	X'TAL : CRYSTAL

## NOTE ON FUSE :

Regarding to all parts of parts code **FS20xxx2xx**, replace only with Wickmann-Werke GmbH, Type 372 non glass type fuse.

## NOTE ON SAFETY :

Symbol  $\blacktriangle$  Fire or electrical shock hazard. Only original parts should be used to replaced any part marked with symbol  $\blacktriangle$ . Any other component substitution (other than original type), may increase risk of fire or electrical shock hazard.

## 安全上の注意 :

$\blacktriangle$  がついている部品は、安全上重要な部品です。必ず指定されている部品番号の部品を使用して下さい。

POS. NO	VERS. COLOR	PART NO. (FOR EUR)	DESCRIPTION	PART NO. (MJJ)	POS. NO	VERS. COLOR	PART NO. (FOR EUR)	DESCRIPTION	PART NO. (MJJ)
<b>PD01-SACD CIRCUIT BOARD PD01-CAPACITORS</b>					<b>PD01-RESISTORS</b>				
C601		nsp	TANTL. CHIP 100µF 6.3V	EY10700620	R632			CHIP 0Ω ±5% 1/16W	NN05000610
C602		nsp	CER. CHIP 0.47µF 16V	DK98474200	R639		nsp		
C605		nsp	TANTL. CHIP 100µF 6.3V	EY10700620	R640		nsp		
C606		nsp	CER. CHIP 0.47µF 16V	DK98474200	R641		nsp	CHIP 22Ω ±5% 1/16W	NN05220610
C611					nsp	TANTL. CHIP 100µF 6.3V	EY10700620	R642	
C612		nsp	CER. CHIP 0.47µF 16V	DK98474200	R643		nsp	CHIP 0Ω ±5% 1/16W	NN05000610
C614		nsp	TANTL. CHIP 100µF 6.3V	EY10700620	R644		nsp	CHIP 22Ω ±5% 1/16W	NN05220610
C615		nsp	CER. CHIP 0.47µF 16V	DK98474200	R645		nsp	CHIP 0Ω ±5% 1/16W	NN05000610
C616		nsp	TANTL. CHIP 100µF 6.3V	EY10700620	R646		nsp	CHIP 47Ω ±5% 1/16W	NN05470610
C617		nsp	CER. CHIP 0.47µF 16V	DK98474200	R647		nsp	CHIP 0Ω ±5% 1/16W	NN05000610
C618		nsp	TANTL. CHIP 100µF 6.3V	EY10700620	R656		nsp	CHIP 0Ω ±5% 1/16W	NN05000610
C619		nsp	CER. CHIP 0.47µF 16V	DK98474200	R659				
C620		nsp	CER. CHIP 0.47µF 16V	DK98474200	R660		nsp	CHIP 22Ω ±5% 1/16W	NN05220610
C621		nsp	TANTL. CHIP 100µF 6.3V	EY10700620	R661		nsp	CHIP 22Ω ±5% 1/16W	NN05220610
C622		nsp	CER. CHIP 0.47µF 16V	DK98474200	R662		nsp	CHIP 22Ω ±5% 1/16W	NN05220610
C623		nsp	CER. CHIP 0.47µF 16V	DK98474200	R663		nsp	CHIP 0Ω ±5% 1/16W	NN05000610
C624		nsp	CER. CHIP 0.01µF ±10% 50V	DK96103300	R701		nsp	CHIP 0Ω ±5% 1/16W	NN05000610
C625		nsp	CER. CHIP 0.01µF ±10% 50V	DK96103300					
C626		nsp	CER. CHIP 0.47µF 16V	DK98474200	R714		nsp	CHIP 10kΩ ±5% 1/16W	NN05103610
C627		nsp	CER. CHIP 0.47µF 16V	DK98474200	R715		nsp	CHIP 10kΩ ±5% 1/16W	NN05103610
C632		nsp	CER. CHIP 47pF ±5% CG 50V	DD95470300	R716		nsp	CHIP 10kΩ ±5% 1/16W	NN05103610
C634		nsp	TANTL. CHIP 100µF 6.3V	EY10700620	R717		nsp	CHIP 10kΩ ±5% 1/16W	NN05103610
C635		nsp	CER. CHIP 0.47µF 16V	DK98474200	R718		nsp	CHIP 22Ω ±5% 1/16W	NN05220610
C641					nsp	CER. CHIP 1µF 10V F	DK98105200	R720	
C642		nsp	CER. CHIP 0.47µF 16V	DK98474200	R722		nsp	CHIP 22Ω ±5% 1/16W	NN05220610
C646		nsp	CER. CHIP 10pF ±0.5pF 50V	DD91100300	R723		nsp	CHIP 22Ω ±5% 1/16W	NN05220610
C647		nsp	TANTL. CHIP 100µF 6.3V	EY10700620	R724		nsp	CHIP 10kΩ ±5% 1/16W	NN05103610
C649		nsp	CER. CHIP 0.47µF 16V	DK98474200	R725		nsp	CHIP 33kΩ ±5% 1/16W	NN05333610
C650		nsp	TANTL. CHIP 100µF 6.3V	EY10700620	R726		nsp	CHIP 0Ω ±5% 1/16W	NN05000610
C651		nsp	CER. CHIP 0.47µF 16V	DK98474200	R727		nsp	CHIP 22Ω ±5% 1/16W	NN05220610
C652		nsp	CER. CHIP 0.47µF 16V	DK98474200	R730		nsp	CHIP 0Ω ±5% 1/16W	NN05000610
C653		nsp	CER. CHIP 0.47µF 16V	DK98474200	R731		nsp	CHIP 0Ω ±5% 1/16W	NN05000610
C701		nsp	CER. CHIP 0.1µF	DK98104200	R732		nsp	CHIP 22Ω ±5% 1/16W	NN05220610
C714					nsp	TANTL. CHIP 100µF 6.3V	EY10700620	R733	
C715		nsp	CER. CHIP 0.47µF 16V	DK98474200	R737		nsp	CHIP 22Ω ±5% 1/16W	NN05220610
C716		nsp	TANTL. CHIP 100µF 6.3V	EY10700620	R738		nsp	CHIP 22Ω ±5% 1/16W	NN05220610
C717		nsp	CER. CHIP 0.47µF 16V	DK98474200	R740		nsp	CHIP 22Ω ±5% 1/16W	NN05220610
C718		nsp	CER. CHIP 0.47µF 16V	DK98474200	R741		nsp	CHIP 0Ω ±5% 1/16W	NN05000610
R601		nsp	CHIP 0Ω ±5% 1/16W	NN05000610	R742		nsp	CHIP 0Ω ±5% 1/16W	NN05000610
R603		nsp	CHIP 0Ω ±5% 1/16W	NN05000610	R743		nsp	CHIP 0Ω ±5% 1/16W	NN05000610
R606					nsp	CHIP 47Ω ±5% 1/16W	NN05470610	R744	
R607		nsp	CHIP 22Ω ±5% 1/16W	NN05220610	R745		nsp	CHIP 0Ω ±5% 1/16W	NN05000610
R608		nsp	CHIP 22Ω ±5% 1/16W	NN05220610	R746		nsp	CHIP 0Ω ±5% 1/16W	NN05000610
R609		nsp	CHIP 22Ω ±5% 1/16W	NN05220610	R747		nsp	CHIP 0Ω ±5% 1/16W	NN05000610
R610		nsp	CHIP 0Ω ±5% 1/16W	NN05000610	R748		nsp	CHIP 10kΩ ±5% 1/16W	NN05103610
R611		BW05103320	RES.COMPO. 10kΩ X 4 J CN1J KOA	BW05103320	R749		nsp	CHIP 0Ω ±5% 1/16W	NN05000610
R612		BW05103320	RES.COMPO. 10kΩ X 4 J CN1J KOA	BW05103320	R750		nsp	CHIP 0Ω ±5% 1/16W	NN05000610
R614		nsp	CHIP 0Ω ±5% 1/16W	NN05000610	R751		nsp	CHIP 0Ω ±5% 1/16W	NN05000610
R616		nsp	CHIP 22Ω ±5% 1/16W	NN05220610	R752		nsp	CHIP 10kΩ ±5% 1/16W	NN05103610
R617		nsp	CHIP 0Ω ±5% 1/16W	NN05000610	R755				
R618		nsp	CHIP 0Ω ±5% 1/16W	NN05000610	R756		nsp	CHIP 0Ω ±5% 1/16W	NN05000610
R619		nsp	CHIP 0Ω ±5% 1/16W	NN05000610	R778				
R620		nsp	CHIP 22Ω ±5% 1/16W	NN05220610	<b>PD01-SEMICONDUCTORS</b>				
R622		nsp	CHIP 0Ω ±5% 1/16W	NN05000610	Q601		HC10081250	IC CXD2753R	HC10081250
R624		nsp	CHIP 22Ω ±5% 1/16W	NN05220610	Q602		HC10214990	IC 2BANKS X 512K X 16BIT SDRAM	HC10214990
R631					nsp	Q603		HC10440050	IC TC7SH08FU
					Q604		HC005605K0	IC TC74VHC74FS	HC005605K0
					Q606		HC98J25210	IC BA25BC0FF +2.5V REG.	HC98J25210
					Q701		HC010205K0	IC TC7SH32FU	HC010205K0
					Q702		HC010205K0	IC TC7SH32FU	HC010205K0
					Q703		HC009105K0	IC TC7WH157FU	HC009105K0
					Q704		HC007905K0	IC TC7WH74FU D-TYPE F.F	HC007905K0

NOTE : "nsp" PART IS LISTED FOR REFERENCE ONLY, MARANTZ WILL NOT SUPPLY THESE PARTS.

POS. NO	VERS. COLOR	PART NO. (FOR EUR)	DESCRIPTION	PART NO. (MJ)	POS. NO	VERS. COLOR	PART NO. (FOR EUR)	DESCRIPTION	PART NO. (MJ)
Q705		HC10436050	IC TC7SH86FU	HC10436050				<b>PF01-FRONT</b>	
Q706		HC010205K0	IC TC7SH32FU	HC010205K0				<b>CIRCUIT BOARD</b>	
Q708		HC010305K0	IC TC7SHU04FU	HC010305K0				<b>PF01-CAPACITORS</b>	
Q709		HC010305K0	IC TC7SHU04FU	HC010305K0	CF01		nsp	CER. CHIP 0.047µF	DK98473300
Q710		HC010305K0	IC TC7SHU04FU	HC010305K0	CF03				
Q711		HC005805K0	IC TC74VHC157FS	HC005805K0	}		nsp	CER. CHIP 100pF ±5% 50V	DD95101300
Q712		HC005805K0	IC TC74VHC157FS	HC005805K0	CF07				
Q713		HC005805K0	IC TC74VHC157FS	HC005805K0	CF08		nsp	CER. CHIP 0.047µF	DK98473300
▲ Q714		HC98J25210	IC BA25BC0FP +2.5V REG.	HC98J25210	CF11		nsp	ELECT. 10µF 16V	EJ10601610
					CF12		nsp	CER. CHIP 0.1µF	DK98104200
J702		YP07005520	<b>PD01-MISCELLANEOUS</b> PLUG 9852B-40A-T	YP07005520	CF13		nsp	ELECT. 100µF 6.3V	EJ10700610
			BOARD TO BOARD		CF16		nsp	CER. CHIP 0.1µF	DK98104200
J704		YP07005520	PLUG 9852B-40A-T	YP07005520	CF17		nsp	CER. CHIP 0.1µF	DK98104200
			BOARD TO BOARD		CF18		nsp	CER. CHIP 0.047µF	DK98473300
L601		nsp	CHIP 0Ω ±5% 1/16W	NN05000610	CF19		nsp	CER. CHIP 0.047µF	DK98473300
					CF20		}		
			<b>PE01-SCART</b>		}		nsp	CER. CHIP 100pF ±5% 50V	DD95101300
			<b>CIRCUIT BOARD [N only]</b>		CF32				
			<b>PE01-CAPACITORS</b>		CF33		nsp	CER. CHIP 0.047µF	DK98473300
C801	/N	nsp	ELECT. 10µF M 16V RA-2	OA10601620	CF34		}		
C802	/N	nsp	CER. 10000pF	DA17103110	CF38		nsp	CER. CHIP 100pF ±5% 50V	DD95101300
C803	/N	nsp	CER. 10000pF	DA17103110	CF39		nsp	CER. CHIP 0.01µF ±10% 50V	DK96103300
C804	/N	nsp	CER. 10000pF	DA17103110	CF40		nsp	ELECT. 47µF 10V	EJ47601010
C805	/N	nsp	ELECT. 100µF M 10V RA-2	OA10701020					
C806	/N	nsp	ELECT. 100µF M 10V RA-2	OA10701020					
C807	/N	nsp	ELECT. 100µF M 10V RA-2	OA10701020	RF01				
C808	/N	nsp	ELECT. 470µF M 6.3V RA-2	OA47700620	RF06		nsp	CHIP 22Ω ±5% 1/16W	NN05220610
C809	/N	nsp	ELECT. 470µF M 6.3V RA-2	OA47700620	RF07				
C811					RF08		nsp	CHIP 4.7kΩ ±5% 1/16W	NN05472610
}	/N	nsp	CER. 10000pF	DA17103110	RF09		nsp	CHIP 4.7kΩ ±5% 1/16W	NN05472610
C814					RF10		nsp	CHIP 10kΩ ±5% 1/16W	NN05103610
C950	/N	nsp	CER. 10000pF	DA17103110	RF11		nsp	CHIP 47kΩ ±5% 1/16W	NN05473610
C951	/N	nsp	CER. 10000pF	DA17103110	RF13	/C/L/S		CHIP 10kΩ ±5% 1/16W	NN05103610
C952					/U				
}	/N	nsp	CER. 330pF	DA16331110	RF14	/A/F/N	nsp	CHIP 10kΩ ±5% 1/16W	NN05103610
C959					RF15	/A/C/L/S		CHIP 10kΩ ±5% 1/16W	NN05103610
					RF16	/F/N/U	nsp	CHIP 10kΩ ±5% 1/16W	NN05103610
					RF17	/N	nsp	CHIP 10kΩ ±5% 1/16W	NN05103610
					RF18	/A/C/F		CHIP 10kΩ ±5% 1/16W	NN05103610
					/L/S/U				
D801					RF19		nsp	CHIP 1kΩ ±5% 1/16W	NN05102610
}	/N	nsp	DIODE 1SS176 MA165	HD20002000	RF20		nsp	CHIP 1kΩ ±5% 1/16W	NN05102610
D804			1SS254 30V 0.1A		RF21		nsp	CHIP 47kΩ ±5% 1/16W	NN05473610
D805					RF22		nsp	CHIP 10kΩ ±5% 1/16W	NN05103610
}	/N	nsp	ZENER DIODE 8.2V	HD30821000	RF23		nsp	CHIP 10kΩ ±5% 1/16W	NN05103610
D814					RF25		nsp	CHIP 47kΩ ±5% 1/16W	NN05473610
D950	/N	nsp	DIODE 1SS176 MA165	HD20002000	RF26		nsp	CHIP 100Ω ±5% 1/16W	NN05101610
			1SS254 30V 0.1A		RF27		nsp	CHIP 100Ω ±5% 1/16W	NN05101610
D951	/N	nsp	DIODE 1SS176 MA165	HD20002000	RF28		nsp	CHIP 22kΩ ±5% 1/16W	NN05223610
			1SS254 30V 0.1A		RF30		nsp	CHIP 10kΩ ±5% 1/16W	NN05103610
					RF31		nsp	CHIP 2.2kΩ ±5% 1/16W	NN05222610
<b>R***</b>			<b>PE01-RESISTORS (COMMON)</b> CARBON FILM FIXED RES. ±5% 1/6W : ALL		RF32		nsp	CHIP 10kΩ ±5% 1/16W	NN05103610
					RF33		nsp	CHIP 100Ω ±5% 1/16W	NN05101610
					RF34		nsp	CHIP 100Ω ±5% 1/16W	NN05101610
J801	/N	YT02210080	TERMINAL YKF41-5038	YT02210080	RF35		nsp	CHIP 47kΩ ±5% 1/16W	NN05473610
			SCART CONNECTOR		RF36		nsp	CHIP 100Ω ±5% 1/16W	NN05101610
J802	/N	YT02210080	TERMINAL YKF41-5038	YT02210080	RF37		nsp	CHIP 100Ω ±5% 1/16W	NN05101610
			SCART CONNECTOR		RF38		nsp	CHIP 100Ω ±5% 1/16W	NN05101610
L801					RF39		}		
}	/N	LY20120620	RELAY ED2-12NU 12V	LY20120620	}		nsp	CHIP 4.7kΩ ±5% 1/16W	NN05472610
L804					RF42				
L950	/N	LY20120620	RELAY ED2-12NU 12V	LY20120620					
L951	/N	LY20120620	RELAY ED2-12NU 12V	LY20120620	RF43		}		
					}		nsp	CHIP 82kΩ ±5% 1/16W	NN05823610
					RF47				
					RF48		nsp	CHIP 270Ω ±5% 1/16W	NN05271610
					RF49		nsp	CHIP 0Ω ±5% 1/16W	NN05000610
					RF52		nsp	CHIP 4.7kΩ ±5% 1/16W	NN05472610

NOTE : "nsp" PART IS LISTED FOR REFERENCE ONLY, MARANTZ WILL NOT SUPPLY THESE PARTS.



POS. NO	VERS. COLOR	PART NO. (FOR EUR)	DESCRIPTION	PART NO. (MJJ)	POS. NO	VERS. COLOR	PART NO. (FOR EUR)	DESCRIPTION	PART NO. (MJJ)
RF53		nsp	CHIP 0Ω ±5% 1/16W	NN05000610	C234	/A/C/N	OF15102550	FILM 1000pF J 100V NH	OF15102550
RF55		nsp	CHIP 22Ω ±5% 1/16W	NN05220610	C234	/F/L/U		FILM 1000pF J 100V APSV	OF15102540
RF56		nsp	CHIP 22Ω ±5% 1/16W	NN05220610	C235	/A/C/N	OF15102550	FILM 1000pF J 100V NH	OF15102550
RF57		nsp	CHIP 22Ω ±5% 1/16W	NN05220610	C235	/F/L/U		FILM 1000pF J 100V APSV	OF15102540
RF60		nsp	CHIP 0Ω ±5% 1/16W	NN05000610	C236	/A/C/N	OF15221550	FILM 220pF J 100V NH	OF15221550
			<b>PF01-SEMICONDUCTORS</b>						
DF01		nsp	CHIP DIODE 1SS301 DAN202U	HZ21005000	C236	/F/L/U		FILM 220pF J 100V PP APSV	OF15221540
DF03		HI10005340	L.E.D. HLMF-K200 #2UL RED	HI10005340	C238	/A/C/N	OF15221550	FILM 220pF J 100V NH	OF15221550
DF04		HI10039080	L.E.D. SELU1E50CM-S BLUE	HI10039080	C238	/F/L/U		FILM 220pF J 100V PP APSV	OF15221540
QF01		*HS02AKT0R	IC TMP87PM74F ONE TIME PROM	*HS02AKT0R	C240	nsp		ELECT. 220μF 16V ARS	OA22701640
QF02		nsp	CHIP TRS. 2SA1586 Y GR 2SA1576A Q R	HX100012A0	C241	nsp		ELECT. 220μF 16V ARS	OA22701640
QF04		HC10098550	IC PST600D-2 RESET IC	HC10098550	C242	nsp		CER. CHIP 270pF ± 5%	DD95271300
QF05		BA10026210	DIG. TRS. DTA114EU	BA10026210	C251	/N		CER. CHIP 270pF ± 5%	DD95271300
QF06		HX300012A0	CHIP TRS. 2SC4081 Q R 2SC4116 Y GR	HX300012A0	C301	nsp		CER. CHIP 33pF ±5% CG 50V	DD95330300
QF07		nsp	CHIP TRS. 2SA1586 Y GR 2SA1576A Q R	HX100012A0	C311	nsp		CER. CHIP 33pF ±5% CG 50V	DD95330300
QF08		HC10033990	IC AT24C04N-10SI-2.5	HC10033990	C321	nsp		CER. CHIP 33pF ±5% CG 50V	DD95330300
			<b>PF01-MISCELLANEOUS</b>		C331	nsp		CER. CHIP 33pF ±5% CG 50V	DD95330300
LF01		nsp	FERRITE CORE CHIP BLM11B601S	FC90020110	C341	nsp		CER. CHIP 33pF ±5% CG 50V	DD95330300
LF03		nsp	FERRITE CORE CHIP BLM11B601S	FC90020110	C351	nsp		CER. CHIP 33pF ±5% CG 50V	DD95330300
SF01		nsp	PUSH SWITCH	SP01012030	C403	/A/C/N	OF15101550	FILM 00pF J 100V	OF15101550
SF07		nsp	SKHVBF 260GF RED		C403	/F/L/U		FILM 100pF J 100V APSV	OF15101540
VF01		HQ31113410	DISPLAY UNIT 11-BT-198GNK	HQ31113410	C404	/A/C/N	OF15102550	FILM 1000pF J 100V NH	OF15102550
XF01		FQ08004060	SERAMIC VIB. CSTS MG 8MHz 15pF	FQ08004060	C404	/F/L/U		FILM 1000pF J 100V APSV	OF15102540
ZF01		nsp	PHOTO UNIT IR SENSOR RPM6936-V4	HW10004210	C405	/A/C/N	OF15102550	FILM 1000pF J 100V NH	OF15102550
			<b>PF02-STAND BY LED CIRCUIT BOARD</b>		C405	/F/L/U		FILM 1000pF J 100V APSV	OF15102540
DF02		HI10005340	L.E.D. HLMF-K200 #2UL RED	HI10005340	C406	/A/C/N	OF15221550	FILM 220pF J 100V NH	OF15221550
			<b>PM01-AV CIRCUIT BOARD</b>		C406	/F/L/U		FILM 220pF J 100V PP APSV	OF15221540
			<b>PM01-CAPACITORS</b>		C408	/A/C/N	OF15221550	FILM 220pF J 100V NH	OF15221550
C200		nsp	ELECT. 100uF M 16V RA-2	OA10701620	C410	nsp		ELECT. 220μF 16V ARS	OA22701640
C203	/A/C/N	OF15101550	FILM 00pF J 100V	OF15101550	C411	nsp		ELECT. 220μF 16V ARS	OA22701640
C203	/F/L/U		FILM 100pF J 100V APSV	OF15101540	C412	nsp		CER. CHIP 270pF ± 5%	DD95271300
C204	/A/C/N	OF15102550	FILM 1000pF J 100V NH	OF15102550	C433	/A/C/N	OF15101550	FILM 00pF J 100V	OF15101550
C204	/F/L/U		FILM 1000pF J 100V APSV	OF15102540	C433	/F/L/U		FILM 100pF J 100V APSV	OF15101540
C205	/A/C/N	OF15102550	FILM 1000pF J 100V NH	OF15102550	C434	/A/C/N	OF15102550	FILM 1000pF J 100V NH	OF15102550
C205	/F/L/U		FILM 1000pF J 100V APSV	OF15102540	C434	/F/L/U		FILM 1000pF J 100V APSV	OF15102540
C206	/A/C/N	OF15221550	FILM 220pF J 100V NH	OF15221550	C435	/A/C/N	OF15102550	FILM 1000pF J 100V NH	OF15102550
C206	/F/L/U		FILM 220pF J 100V PP APSV	OF15221540	C435	/F/L/U		FILM 1000pF J 100V APSV	OF15102540
C208	/A/C/N	OF15221550	FILM 220pF J 100V NH	OF15221550	C436	/A/C/N	OF15221550	FILM 220pF J 100V NH	OF15221550
C208	/F/L/U		FILM 220pF J 100V PP APSV	OF15221540	C436	/F/L/U		FILM 220pF J 100V PP APSV	OF15221540
C210		nsp	ELECT. 220μF 16V ARS	OA22701640	C438	/A/C/N	OF15221550	FILM 220pF J 100V NH	OF15221550
C211		nsp	ELECT. 220μF 16V ARS	OA22701640	C440	nsp		ELECT. 220μF 16V ARS	OA22701640
C212		nsp	CER.CHIP 270pF ± 5%	DD95271300	C441	nsp		ELECT. 220μF 16V ARS	OA22701640
C221	/N	nsp	CER.CHIP 270pF ± 5%	DD95271300	C442	nsp		CER. CHIP 270pF ± 5%	DD95271300
C233	/A/C/N	OF15101550	FILM 00pF J 100V	OF15101550	C503	/A/C/N	OF15101550	FILM 00pF J 100V	OF15101550
C233	/F/L/U		FILM 100pF J 100V APSV	OF15101540	C503	/F/L/U		FILM 100pF J 100V APSV	OF15101540
C233	/L1G		FILM 100pF J 100V APSV	OF15101540	C504	/A/C/N	OF15102550	FILM 1000pF J 100V NH	OF15102550
					C504	/F/L/U		FILM 1000pF J 100V APSV	OF15102540
					C505	/A/C/N	OF15102550	FILM 1000pF J 100V NH	OF15102550
					C505	/F/L/U		FILM 1000pF J 100V APSV	OF15102540

NOTE : "nsp" PART IS LISTED FOR REFERENCE ONLY, MARANTZ WILL NOT SUPPLY THESE PARTS.

POS. NO	VERS. COLOR	PART NO. (FOR EUR)	DESCRIPTION	PART NO. (MJ)	POS. NO	VERS. COLOR	PART NO. (FOR EUR)	DESCRIPTION	PART NO. (MJ)
C506	/A/C/N /S	OF15221550	FILM 220pF J 100V NH	OF15221550	CA11		nsp	CER. CHIP 820pF ± 10%	DK96821300
C506	/F/L/U		FILM 220pF J 100V PP APSV	OF15221540	CA12		nsp	CER. CHIP 0.0039µF W5R	DK96392300
C508	/A/C/N /S	OF15221550	FILM 220pF J 100V NH	OF15221550	CA14				
C508	/F/L/U		FILM 220pF J 100V PP APSV	OF15221540	CA17		nsp	CER. CHIP 0.1µF	DK98104200
C510		nsp	ELECT. 220µF 16V ARS	OA22701640	CA18		nsp	CER. CHIP 1µF 10V F	DK98105200
C511		nsp	ELECT. 220µF 16V ARS	OA22701640	CA20		nsp	ELECT. 470µF M 10V RA-2	OA47701020
C512		nsp	CER. CHIP 270pF ± 5%	DD95271300	CA21		nsp	CER. CHIP 0.1µF	DK98104200
C533	/A/C/N /S	OF15101550	FILM 00pF J 100V	OF15101550	CA22		nsp	CER. CHIP 0.1µF	DK98104200
C533	/F/L/U		FILM 100pF J 100V APSV	OF15101540	CA23		nsp	CER. CHIP 0.1µF	DK98104200
C534	/A/C/N /S	OF15102550	FILM 1000pF J 100V NH	OF15102550	CA24		nsp	CER. CHIP 0.01µF ±10% 50V	DK96103300
C534	/F/L/U		FILM 1000pF J 100V APSV	OF15102540	CA25		nsp	CER. CHIP 0.01µF ±10% 50V	DK96103300
C535	/A/C/N /S	OF15102550	FILM 1000pF J 100V NH	OF15102550	CA26		nsp	CER. CHIP 0.01µF ±10% 50V	DK96103300
C535	/F/L/U		FILM 1000pF J 100V APSV	OF15102540	CA28		nsp	ELECT. 100µF M 10V RA-2	OA10701020
C536	/A/C/N /S	OF15221550	FILM 220pF J 100V NH	OF15221550	CB01	/N	nsp	CER. CHIP 0.01µF ±10% 50V	DK96103300
C536	/F/L/U		FILM 220pF J 100V PP APSV	OF15221540	CB02		nsp	CER. CHIP 10pF ±0.5pF 50V	DD91100300
C538	/A/C/N /S	OF15221550	FILM 220pF J 100V NH	OF15221550	CB03		nsp	CER. CHIP 3pF ±0.25pF 50V	DD90030300
C538	/F/L/U		FILM 220pF J 100V PP APSV	OF15221540	CB04		nsp	CER. CHIP 33pF ±5% CG 50V	DD95330300
C540		nsp	ELECT. 220µF 16V ARS	OA22701640	CB05		nsp	CER. CHIP 7pF ±0.5pF 50V	DD91070300
C541		nsp	ELECT. 220µF 16V ARS	OA22701640	CB06		nsp	CER. CHIP 22pF ±5% CG 50V	DD95220300
C542		nsp	CER. CHIP 270pF ± 5%	DD95271300	CB07		nsp	CER. CHIP 0.01µF ±10% 50V	DK96103300
C852	/N	nsp	CER. CHIP 27pF	DD95270300	CB08		nsp	ELECT. 10µF M 50V RA-2	OA10605020
C853	/N	nsp	CER. CHIP 3pF ±0.25pF 50V	DD90030300	CB09		nsp	ELECT. 470µF M 6.3V RA-2	OA47700620
C854	/N	nsp	CER. CHIP 68pF	DD95680300	CB11	/A/C/F /L/S	nsp	ELECT. 470µF M 6.3V RA-2	OA47700620
C855	/N	nsp	CER. CHIP 5pF ±0.25pF 50V	DD90050300	CC01	/N	nsp	CER. CHIP 0.01µF ±10% 50V	DK96103300
C856	/N	nsp	CER. CHIP 56pF	DD95560300	CC02		nsp	CER. CHIP 10pF ±0.5pF 50V	DD91100300
C857	/N	nsp	CER. CHIP 0.01µF ±10% 50V	DK96103300	CC03		nsp	CER. CHIP 3pF ±0.25pF 50V	DD90030300
C859	/N	nsp	ELECT. 10µF M 50V RA-2	OA10605020	CC04		nsp	CER. CHIP 33pF ±5% CG 50V	DD95330300
C860	/N	nsp	CER. CHIP 0.01µF ±10% 50V	DK96103300	CC05		nsp	CER. CHIP 7pF ±0.5pF 50V	DD91070300
C862	/N	nsp	CER. CHIP 27pF	DD95270300	CC06		nsp	CER. CHIP 22pF ±5% CG 50V	DD95220300
C863	/N	nsp	CER. CHIP 3pF ±0.25pF 50V	DD90030300	CC07		nsp	CER. CHIP 0.01µF ±10% 50V	DK96103300
C864	/N	nsp	CER. CHIP 68pF	DD95680300	CC08		nsp	ELECT. 10µF M 50V RA-2	OA10605020
C865	/N	nsp	CER. CHIP 5pF ±0.25pF 50V	DD90050300	CC09		nsp	ELECT. 470µF M 6.3V RA-2	OA47700620
C866	/N	nsp	CER. CHIP 56pF	DD95560300	CC11	/A/C/F /L/S	nsp	ELECT. 470µF M 6.3V RA-2	OA47700620
C867	/N	nsp	CER. CHIP 0.01µF ±10% 50V	DK96103300	CD01		nsp	ELECT. 220µF 16V ARA CERAFINE	OA22701650
C868	/N	nsp	ELECT. 10µF M 50V RA-2	OA10605020	CD02		nsp	CER. CHIP 0.1µF	DK98104200
C869	/N	nsp	CER. CHIP 0.01µF ±10% 50V	DK96103300	CD03		nsp	ELECT. 1µF M 50V RA-2	OA10505020
C871	/N	nsp	CER. CHIP 27pF	DD95270300	CD04		nsp	CER. CHIP 0.1µF	DK98104200
C872	/N	nsp	CER. CHIP 3pF ±0.25pF 50V	DD90030300	CD05		nsp	ELECT. 1µF M 50V RA-2	OA10505020
C873	/N	nsp	CER. CHIP 68pF	DD95680300	CD06		nsp	CER. CHIP 0.1µF	DK98104200
C874	/N	nsp	CER. CHIP 5pF ±0.25pF 50V	DD90050300	CD07		nsp	ELECT. 100µF 10V ARA	OA10701050
C875	/N	nsp	CER. CHIP 56pF	DD95560300	CD08		nsp	CER. CHIP 1µF 10V F	DK98105200
C876	/N	nsp	CER. CHIP 0.01µF ±10% 50V	DK96103300	CD21		nsp	ELECT. 220µF 16V ARA CERAFINE	OA22701650
C877	/N	nsp	ELECT. 10µF M 50V RA-2	OA10605020	CD22		nsp	CER. CHIP 0.1µF	DK98104200
C878	/N	nsp	CER. CHIP 0.1µF	DK98104200	CD23		nsp	ELECT. 1µF M 50V RA-2	OA10505020
C879	/N	nsp	CER. CHIP 0.01µF ±10% 50V	DK96103300	CD24		nsp	CER. CHIP 0.1µF	DK98104200
C880	/N	nsp	ELECT. 10µF M 50V RA-2	OA10605020	CD25		nsp	ELECT. 1µF M 50V RA-2	OA10505020
C881	/N	nsp	ELECT. 10µF M 50V RA-2	OA10605020	CD26		nsp	CER. CHIP 0.1µF	DK98104200
C882	/N	nsp	ELECT. 10µF M 50V RA-2	OA10605020	CD27		nsp	ELECT. 100µF 10V ARA	OA10701050
C883	/N	nsp	CER. CHIP 0.01µF ±10% 50V	DK96103300	CD28		nsp	CER. CHIP 1µF 10V F	DK98105200
C884	/N	nsp	ELECT. 10µF M 50V RA-2	OA10605020	CD41		nsp	ELECT. 220µF 16V ARA CERAFINE	OA22701650
C885	/N	nsp	CER. CHIP 0.01µF ±10% 50V	DK96103300	CD42		nsp	CER. CHIP 0.1µF	DK98104200
C886	/N	nsp	CER. CHIP 0.1µF	DK98104200	CD43		nsp	ELECT. 1µF M 50V RA-2	OA10505020
C887	/N	nsp	CER. CHIP 0.1µF	DK98104200	CD44		nsp	CER. CHIP 0.1µF	DK98104200
C888	/N	nsp	CER. CHIP 0.1µF	DK98104200	CD45		nsp	ELECT. 1µF M 50V RA-2	OA10505020
C889	/N	nsp	CER. CHIP 0.1µF	DK98104200	CD46		nsp	CER. CHIP 0.1µF	DK98104200
CA01		nsp	ELECT. 100µF M 10V RA-2	OA10701020	CD47		nsp	ELECT. 100µF 10V ARA	OA10701050
CA02					CD48		nsp	CER. CHIP 1µF 10V F	DK98105200
CA06		nsp	CER. CHIP 0.1µF	DK98104200	CE02		nsp	CER. CHIP 0.1µF	DK98104200
CA10		nsp	CER. CHIP 100pF ±5% 50V	DD95101300	CE13		nsp	ELECT. 100µF M 10V RA-2	OA10701020
					CE14		nsp	ELECT. 100µF M 10V RA-2	OA10701020

NOTE : "nsp" PART IS LISTED FOR REFERENCE ONLY, MARANTZ WILL NOT SUPPLY THESE PARTS.

POS. NO	VERS. COLOR	PART NO. (FOR EUR)	DESCRIPTION	PART NO. (MJJ)	POS. NO	VERS. COLOR	PART NO. (FOR EUR)	DESCRIPTION	PART NO. (MJJ)
CE15					CV42		nsp	CER. CHIP 0.1µF	DK98104200
CE21		nsp	CER. CHIP 0.1µF	DK98104200	CV43		nsp	ELECT. 1000µF 6.3V M RA-2	OA10800620
CE23					CV44		nsp	ELECT. 1000µF 6.3V M RA-2	OA10800620
CE26		nsp	CER. CHIP 0.1µF	DK98104200	CV45		nsp	CER. CHIP 0.1µF	DK98104200
CE27		nsp	ELECT. 100µF M 10V RA-2	OA10701020	CV46		nsp	ELECT. 1000µF 6.3V M RA-2	OA10800620
CE28		nsp	ELECT. 100µF M 10V RA-2	OA10701020	CV51		nsp	CER. CHIP 0.1µF	DK98104200
CE29					CV52		nsp	ELECT. 470µF 16V M RA-2	OA47701620
CE33		nsp	CER. CHIP 0.1µF	DK98104200	CV53		nsp	CER. CHIP 0.1µF	DK98104200
CE35		nsp	CER. CHIP 0.1µF	DK98104200	CY01	/N	nsp	CER. CHIP 0.01µF ±10% 50V	DK96103300
CE36		nsp	CER. CHIP 0.01µF ±10% 50V	DK96103300	CY02		nsp	CER. CHIP 10pF ±0.5pF 50V	DD91100300
CE37		nsp	CER. CHIP 0.1µF	DK98104200	CY03		nsp	CER. CHIP 3pF ±0.25pF 50V	DD90030300
CE38		nsp	ELECT. 100µF M 10V RA-2	OA10701020	CY04		nsp	CER. CHIP 33pF ±5% CG 50V	DD95330300
CE39					CY05		nsp	CER. CHIP 7pF ±0.5pF 50V	DD91070300
CE51		nsp	CER. CHIP 0.1µF	DK98104200	CY06		nsp	CER. CHIP 22pF ±5% CG 50V	DD95220300
CE52		nsp	ELECT. 100µF M 10V RA-2	OA10701020	CY07		nsp	CER. CHIP 0.01µF ±10% 50V	DK96103300
CE53		nsp	CER. CHIP 0.1µF	DK98104200	CY08		nsp	ELECT. 100µF M 10V RA-2	OA10701020
CE54		nsp	ELECT. 100µF M 10V RA-2	OA10701020	CY09		nsp	ELECT. 10µF M 50V RA-2	OA10605020
CE55		nsp	CER. CHIP 0.1µF	DK98104200	CY10		nsp	ELECT. 100µF M 16V RA-2	OA10701620
CE56		nsp	ELECT. 100µF M 10V RA-2	OA10701020	CY11		nsp	CER. CHIP 0.1µF	DK98104200
CI02		nsp	CER. CHIP 0.1µF	DK98104200	CY12		nsp	CER. CHIP 47pF ±5% CG 50V	DD95470300
CI05		nsp	ELECT. 1µF M 50V RA-2	OA10505020	CY13		nsp	CER. CHIP 47pF ±5% CG 50V	DD95470300
CI10		nsp	CER. CHIP 0.01µF ±10% 50V	DK96103300	CY14		nsp	ELECT. 100µF M 16V RA-2	OA10701620
CI11		nsp	ELECT. 100µF M 10V RA-2	OA10701020	CY15		nsp	CER. CHIP 0.1µF	DK98104200
CI12		nsp	CER. CHIP 220pF	DK96221300	CY16		nsp	CER. CHIP 0.1µF	DK98104200
CI13		nsp	CER. CHIP 1µF 10V F	DK98105200	CY17		nsp	ELECT. 470µF 16V M RA-2	OA47701620
CI20		nsp	ELECT. 47µF M 16VRA-2	OA47601620	CY18		nsp	ELECT. 1000µF 6.3V M RA-2	OA10800620
CI21		nsp	CER. CHIP 0.01µF ±10% 50V	DK96103300	CY19		nsp	ELECT. 1000µF 6.3V M RA-2	OA10800620
CI31		nsp	CER. CHIP 0.1µF	DK98104200	CY20	/A/C/F /L/S		ELECT. 1000µF 6.3V M RA-2	OA10800620
CV01		nsp	ELECT. 470µF M 10V RA-2	OA47701020	CY22	/A/C/F /L/S		CER. CHIP 0.1µF	DK98104200
CV02		nsp	CER. CHIP 0.1µF	DK98104200	CY23	/A/C/F /L/S		CER. CHIP 0.1µF	DK98104200
CV03		nsp	ELECT. 1µF M 50V RA-2	OA10505020					
CV04		nsp	ELECT. 470µF M 10V RA-2	OA47701020	R201		nsp	CHIP 2.2kΩ ±5% 1/16W	NN05222610
CV05		nsp	CER. CHIP 0.1µF	DK98104200	R206				
CV06		nsp	ELECT. 470µF 16V M RA-2	OA47701620	R207		nsp	CHIP 12kΩ ±5% 1/16W	NN05123610
CV07		nsp	CER. CHIP 0.1µF	DK98104200	R208		nsp	CHIP 15kΩ ±5% 1/16W	NN05153610
CV08		nsp	ELECT. 470µF 16V M RA-2	OA47701620	R209		nsp	CHIP 12kΩ ±5% 1/16W	NN05123610
CV09		nsp	CER. CHIP 0.1µF	DK98104200	R210		nsp	CHIP 15kΩ ±5% 1/16W	NN05153610
CV10		nsp	CER. CHIP 0.01µF ±10% 50V	DK96103300	R211		nsp	10Ω ±5% 1/6W	GG05100160
CV11		nsp	CER. CHIP 10pF ±0.5pF 50V	DD91100300	R212		nsp	10Ω ±5% 1/6W	GG05100160
CV13		nsp	CER. CHIP 33pF ±5% CG 50V	DD95330300	R213		nsp	CHIP 100kΩ ±5% 1/16W	NN05104610
CV15		nsp	CER. CHIP 47pF ±5% CG 50V	DD95470300	R215		nsp	CHIP 220Ω ±5% 1/16W	NN05221610
CV16		nsp	CER. CHIP 0.01µF ±10% 50V	DK96103300	R216		nsp	CHIP 22kΩ ±5% 1/16W	NN05223610
CV17		nsp	ELECT. 100µF M 10V RA-2	OA10701020	R217		nsp	CHIP 220kΩ ±5% 1/16W	NN05224610
CV18		nsp	CER. CHIP 0.01µF ±10% 50V	DK96103300	R219		nsp	CHIP 2.2kΩ ±5% 1/16W	NN05222610
CV19		nsp	CER. CHIP 10pF ±0.5pF 50V	DD91100300	R220	/N	nsp	CHIP 0Ω ±5% 1/16W	NN05000610
CV21		nsp	CER. CHIP 33pF ±5% CG 50V	DD95330300	R221	/N	nsp	CHIP 220Ω ±5% 1/16W	NN05221610
CV23		nsp	CER. CHIP 47pF ±5% CG 50V	DD95470300	R222	/N	nsp	CHIP 22kΩ ±5% 1/16W	NN05223610
CV24		nsp	CER. CHIP 0.01µF ±10% 50V	DK96103300	R224	/N	nsp	CHIP 2.2kΩ ±5% 1/16W	NN05222610
CV25		nsp	CER. CHIP 0.01µF ±10% 50V	DK96103300	R225		nsp	CHIP 1kΩ ±5% 1/16W	NN05102610
CV26		nsp	CER. CHIP 10pF ±0.5pF 50V	DD91100300	R226		nsp	CHIP 1kΩ ±5% 1/16W	NN05102610
CV28		nsp	CER. CHIP 33pF ±5% CG 50V	DD95330300	R227		nsp	CHIP 3.3kΩ ±5% 1/16W	NN05332610
CV30		nsp	CER. CHIP 47pF ±5% CG 50V	DD95470300	R228		nsp	CHIP 10kΩ ±5% 1/16W	NN05103610
CV31		nsp	CER. CHIP 0.01µF ±10% 50V	DK96103300	R231		nsp	CHIP 3.3kΩ ±5% 1/16W	NN05332610
CV32		nsp	ELECT. 10µF M 50V RA-2	OA10605020	R232		nsp	CHIP 3.3kΩ ±5% 1/16W	NN05332610
CV33		nsp	CER. CHIP 0.1µF	DK98104200	R233		nsp	CHIP 2.2kΩ ±5% 1/16W	NN05222610
CV34		nsp	ELECT. 10µF M 50V RA-2	OA10605020	R236				
CV35		nsp	ELECT. 100µF M 16V RA-2	OA10701620	R237		nsp	CHIP 12kΩ ±5% 1/16W	NN05123610
CV36		nsp	CER. CHIP 0.1µF	DK98104200	R238		nsp	CHIP 15kΩ ±5% 1/16W	NN05153610
CV37		nsp	CER. CHIP 47pF ±5% CG 50V	DD95470300	R239		nsp	CHIP 12kΩ ±5% 1/16W	NN05123610
CV38		nsp	CER. CHIP 47pF ±5% CG 50V	DD95470300	R240		nsp	CHIP 15kΩ ±5% 1/16W	NN05153610
CV39		nsp	ELECT. 100µF M 16V RA-2	OA10701620	R241		nsp	10Ω ±5% 1/6W	GG05100160
CV40		nsp	CER. CHIP 0.1µF	DK98104200	R242		nsp	10Ω ±5% 1/6W	GG05100160
CV41		nsp	CER. CHIP 0.1µF	DK98104200	R243		nsp	CHIP 100kΩ ±5% 1/16W	NN05104610
					R245		nsp	CHIP 220Ω ±5% 1/16W	NN05221610

NOTE : "nsp" PART IS LISTED FOR REFERENCE ONLY, MARANTZ WILL NOT SUPPLY THESE PARTS.

POS. NO	VERS. COLOR	PART NO. (FOR EUR)	DESCRIPTION	PART NO. (MJJ)	POS. NO	VERS. COLOR	PART NO. (FOR EUR)	DESCRIPTION	PART NO. (MJJ)
R246		nsp	CHIP 22kΩ ±5% 1/16W	NN05223610	R403				
R247		nsp	CHIP 220kΩ ±5% 1/16W	NN05224610	∫		nsp	CHIP 2.2kΩ ±5% 1/16W	NN05222610
R249		nsp	CHIP 2.2kΩ ±5% 1/16W	NN05222610	R406				
R250	/N	nsp	CHIP 0Ω ±5% 1/16W	NN05000610	R407		nsp	CHIP 12kΩ ±5% 1/16W	NN05123610
R251	/N	nsp	CHIP 220Ω ±5% 1/16W	NN05221610	R408		nsp	CHIP 15kΩ ±5% 1/16W	NN05153610
R252	/N	nsp	CHIP 22kΩ ±5% 1/16W	NN05223610	R409		nsp	CHIP 12kΩ ±5% 1/16W	NN05123610
R254	/N	nsp	CHIP 2.2kΩ ±5% 1/16W	NN05222610	R410		nsp	CHIP 15kΩ ±5% 1/16W	NN05153610
R255		nsp	CHIP 1kΩ ±5% 1/16W	NN05102610	R411		nsp	10Ω ±5% 1/6W	GG05100160
R256		nsp	CHIP 1kΩ ±5% 1/16W	NN05102610	R412		nsp	10Ω ±5% 1/6W	GG05100160
R257		nsp	CHIP 3.3kΩ ±5% 1/16W	NN05332610	R413		nsp	CHIP 100kΩ ±5% 1/16W	NN05104610
R258		nsp	CHIP 10kΩ ±5% 1/16W	NN05103610	R415		nsp	CHIP 220Ω ±5% 1/16W	NN05221610
					R416		nsp	CHIP 22kΩ ±5% 1/16W	NN05223610
R301		nsp	CHIP 150Ω ±5% 1/16W	NN05151610	R417		nsp	CHIP 220kΩ ±5% 1/16W	NN05224610
R302		nsp	CHIP 150Ω ±5% 1/16W	NN05151610	R419		nsp	CHIP 2.2kΩ ±5% 1/16W	NN05222610
R303		nsp	CHIP 100Ω ±5% 1/16W	NN05101610	R425		nsp	CHIP 1kΩ ±5% 1/16W	NN05102610
R304		nsp	CHIP 100Ω ±5% 1/16W	NN05101610	R426		nsp	CHIP 1kΩ ±5% 1/16W	NN05102610
R305		nsp	CHIP 100Ω ±5% 1/16W	NN05101610	R427		nsp	CHIP 3.3kΩ ±5% 1/16W	NN05332610
R306		nsp	CHIP 33kΩ ±5% 1/16W	NN05333610	R428		nsp	CHIP 10kΩ ±5% 1/16W	NN05103610
R307		nsp	CHIP 560Ω ±5% 1/16W	NN05561610					
R308		nsp	CHIP 560Ω ±5% 1/16W	NN05561610	R431		nsp	CHIP 3.3kΩ ±5% 1/16W	NN05332610
R309		nsp	CHIP 100Ω ±5% 1/16W	NN05101610	R432		nsp	CHIP 3.3kΩ ±5% 1/16W	NN05332610
R311		nsp	CHIP 150Ω ±5% 1/16W	NN05151610	R433				
R312		nsp	CHIP 150Ω ±5% 1/16W	NN05151610	∫		nsp	CHIP 2.2kΩ ±5% 1/16W	NN05222610
R313		nsp	CHIP 100Ω ±5% 1/16W	NN05101610	R436				
R314		nsp	CHIP 100Ω ±5% 1/16W	NN05101610	R437		nsp	CHIP 12kΩ ±5% 1/16W	NN05123610
R315		nsp	CHIP 100Ω ±5% 1/16W	NN05101610	R438		nsp	CHIP 15kΩ ±5% 1/16W	NN05153610
R316		nsp	CHIP 33kΩ ±5% 1/16W	NN05333610	R439		nsp	CHIP 12kΩ ±5% 1/16W	NN05123610
R317		nsp	CHIP 560Ω ±5% 1/16W	NN05561610	R440		nsp	CHIP 15kΩ ±5% 1/16W	NN05153610
R318		nsp	CHIP 560Ω ±5% 1/16W	NN05561610	R441		nsp	10Ω ±5% 1/6W	GG05100160
R319		nsp	CHIP 100Ω ±5% 1/16W	NN05101610	R442		nsp	10Ω ±5% 1/6W	GG05100160
R321		nsp	CHIP 150Ω ±5% 1/16W	NN05151610	R443		nsp	CHIP 100kΩ ±5% 1/16W	NN05104610
R322		nsp	CHIP 150Ω ±5% 1/16W	NN05151610	R445		nsp	CHIP 220Ω ±5% 1/16W	NN05221610
R323		nsp	CHIP 100Ω ±5% 1/16W	NN05101610	R446		nsp	CHIP 22kΩ ±5% 1/16W	NN05223610
R324		nsp	CHIP 100Ω ±5% 1/16W	NN05101610	R447		nsp	CHIP 220kΩ ±5% 1/16W	NN05224610
R325		nsp	CHIP 100Ω ±5% 1/16W	NN05101610	R449		nsp	CHIP 2.2kΩ ±5% 1/16W	NN05222610
R326		nsp	CHIP 33kΩ ±5% 1/16W	NN05333610	R455		nsp	CHIP 1kΩ ±5% 1/16W	NN05102610
R327		nsp	CHIP 560Ω ±5% 1/16W	NN05561610	R456		nsp	CHIP 1kΩ ±5% 1/16W	NN05102610
R328		nsp	CHIP 560Ω ±5% 1/16W	NN05561610	R457		nsp	CHIP 3.3kΩ ±5% 1/16W	NN05332610
R329		nsp	CHIP 100Ω ±5% 1/16W	NN05101610	R458		nsp	CHIP 10kΩ ±5% 1/16W	NN05103610
R331		nsp	CHIP 150Ω ±5% 1/16W	NN05151610	R501		nsp	CHIP 3.3kΩ ±5% 1/16W	NN05332610
R332		nsp	CHIP 150Ω ±5% 1/16W	NN05151610	R502		nsp	CHIP 3.3kΩ ±5% 1/16W	NN05332610
R333		nsp	CHIP 100Ω ±5% 1/16W	NN05101610	R503				
R334		nsp	CHIP 100Ω ±5% 1/16W	NN05101610	∫		nsp	CHIP 2.2kΩ ±5% 1/16W	NN05222610
R335		nsp	CHIP 100Ω ±5% 1/16W	NN05101610	R506				
R336		nsp	CHIP 33kΩ ±5% 1/16W	NN05333610	R507		nsp	CHIP 12kΩ ±5% 1/16W	NN05123610
R337		nsp	CHIP 560Ω ±5% 1/16W	NN05561610	R508		nsp	CHIP 15kΩ ±5% 1/16W	NN05153610
R338		nsp	CHIP 560Ω ±5% 1/16W	NN05561610	R509		nsp	CHIP 12kΩ ±5% 1/16W	NN05123610
R339		nsp	CHIP 100Ω ±5% 1/16W	NN05101610	R510		nsp	CHIP 15kΩ ±5% 1/16W	NN05153610
R341		nsp	CHIP 150Ω ±5% 1/16W	NN05151610	R511		nsp	10Ω ±5% 1/6W	GG05100160
R342		nsp	CHIP 150Ω ±5% 1/16W	NN05151610	R512		nsp	10Ω ±5% 1/6W	GG05100160
R343		nsp	CHIP 100Ω ±5% 1/16W	NN05101610	R513		nsp	CHIP 100kΩ ±5% 1/16W	NN05104610
R344		nsp	CHIP 100Ω ±5% 1/16W	NN05101610	R515		nsp	CHIP 220Ω ±5% 1/16W	NN05221610
R345		nsp	CHIP 100Ω ±5% 1/16W	NN05101610	R516		nsp	CHIP 22kΩ ±5% 1/16W	NN05223610
R346		nsp	CHIP 33kΩ ±5% 1/16W	NN05333610	R517		nsp	CHIP 220kΩ ±5% 1/16W	NN05224610
R347		nsp	CHIP 560Ω ±5% 1/16W	NN05561610	R519		nsp	CHIP 2.2kΩ ±5% 1/16W	NN05222610
R348		nsp	CHIP 560Ω ±5% 1/16W	NN05561610	R525		nsp	CHIP 1kΩ ±5% 1/16W	NN05102610
R349		nsp	CHIP 100Ω ±5% 1/16W	NN05101610	R526		nsp	CHIP 1kΩ ±5% 1/16W	NN05102610
R351		nsp	CHIP 150Ω ±5% 1/16W	NN05151610	R527		nsp	CHIP 3.3kΩ ±5% 1/16W	NN05332610
R352		nsp	CHIP 150Ω ±5% 1/16W	NN05151610	R528		nsp	CHIP 10kΩ ±5% 1/16W	NN05103610
R353		nsp	CHIP 100Ω ±5% 1/16W	NN05101610	R531		nsp	CHIP 3.3kΩ ±5% 1/16W	NN05332610
R354		nsp	CHIP 100Ω ±5% 1/16W	NN05101610	R532		nsp	CHIP 3.3kΩ ±5% 1/16W	NN05332610
R355		nsp	CHIP 100Ω ±5% 1/16W	NN05101610	R533				
R356		nsp	CHIP 33kΩ ±5% 1/16W	NN05333610	∫		nsp	CHIP 2.2kΩ ±5% 1/16W	NN05222610
R357		nsp	CHIP 560Ω ±5% 1/16W	NN05561610	R536				
R358		nsp	CHIP 560Ω ±5% 1/16W	NN05561610	R537		nsp	CHIP 12kΩ ±5% 1/16W	NN05123610
R359		nsp	CHIP 100Ω ±5% 1/16W	NN05101610	R538		nsp	CHIP 15kΩ ±5% 1/16W	NN05153610
					R539		nsp	CHIP 12kΩ ±5% 1/16W	NN05123610
R401		nsp	CHIP 3.3kΩ ±5% 1/16W	NN05332610	R540		nsp	CHIP 15kΩ ±5% 1/16W	NN05153610
R402		nsp	CHIP 3.3kΩ ±5% 1/16W	NN05332610	R541		nsp	10Ω ±5% 1/6W	GG05100160

NOTE : "nsp" PART IS LISTED FOR REFERENCE ONLY, MARANTZ WILL NOT SUPPLY THESE PARTS.

POS. NO	VERS. COLOR	PART NO. (FOR EUR)	DESCRIPTION	PART NO. (MJJ)	POS. NO	VERS. COLOR	PART NO. (FOR EUR)	DESCRIPTION	PART NO. (MJJ)
R542		nsp	10Ω ±5% 1/6W	GG05100160	RA33		nsp	CHIP 560Ω ±5% 1/16W	NN05561610
R543		nsp	CHIP 100kΩ ±5% 1/16W	NN05104610	RA34		nsp	CHIP 100Ω ±5% 1/16W	NN05101610
R545		nsp	CHIP 220Ω ±5% 1/16W	NN05221610	RA35		nsp	CHIP 1.8kΩ ±5% 1/16W	NN05182610
R546		nsp	CHIP 22kΩ ±5% 1/16W	NN05223610	RA36		nsp	CHIP 680Ω ±5% 1/16W	NN05681610
R547		nsp	CHIP 220kΩ ±5% 1/16W	NN05224610	RA37		nsp	CHIP 560Ω ±5% 1/16W	NN05561610
R549		nsp	CHIP 2.2kΩ ±5% 1/16W	NN05222610	RA38		nsp	CHIP 100Ω ±5% 1/16W	NN05101610
R555		nsp	CHIP 1kΩ ±5% 1/16W	NN05102610	RA39		nsp	CHIP 1.8kΩ ±5% 1/16W	NN05182610
R556		nsp	CHIP 1kΩ ±5% 1/16W	NN05102610					
R557		nsp	CHIP 3.3kΩ ±5% 1/16W	NN05332610	RA40		nsp	CHIP 680Ω ±5% 1/16W	NN05681610
R558		nsp	CHIP 10kΩ ±5% 1/16W	NN05103610	RA41		nsp	CHIP 560Ω ±5% 1/16W	NN05561610
					RA42		nsp	CHIP 100Ω ±5% 1/16W	NN05101610
R855	/N	nsp	CHIP 470Ω ±5% 1/16W	NN05471610	RA43		nsp	CHIP 1.8kΩ ±5% 1/16W	NN05182610
R856	/N	nsp	CHIP 22kΩ ±5% 1/16W	NN05223610	RA44	/A/C/F		CHIP 0Ω ±5% 1/16W	NN05000610
R857	/N	nsp	CHIP 2.2kΩ ±5% 1/16W	NN05222610		/L/S/U			
R858	/N	nsp	CHIP 0Ω ±5% 1/16W	NN05000610	RA45	/N	nsp	CHIP 0Ω ±5% 1/16W	NN05000610
R864	/N	nsp	CHIP 470Ω ±5% 1/16W	NN05471610	RA46	/A/C/F		CHIP 0Ω ±5% 1/16W	NN05000610
R865	/N	nsp	CHIP 22kΩ ±5% 1/16W	NN05223610		/L/S/U			
R866	/N	nsp	CHIP 2.2kΩ ±5% 1/16W	NN05222610	RA47	/N	nsp	CHIP 0Ω ±5% 1/16W	NN05000610
R867	/N	nsp	CHIP 0Ω ±5% 1/16W	NN05000610	RA48	/A/C/F		CHIP 0Ω ±5% 1/16W	NN05000610
R873	/N	nsp	CHIP 470Ω ±5% 1/16W	NN05471610		/L/S/U			
R874	/N	nsp	CHIP 22kΩ ±5% 1/16W	NN05223610	RA49	/N	nsp	CHIP 0Ω ±5% 1/16W	NN05000610
R875	/N	nsp	CHIP 2.2kΩ ±5% 1/16W	NN05222610	RA50		nsp	CHIP 0Ω ±5% 1/16W	NN05000610
R876	/N	nsp	CHIP 0Ω ±5% 1/16W	NN05000610	RA51		nsp	CHIP 0Ω ±5% 1/16W	NN05000610
R878	/N	nsp	CHIP 0Ω ±5% 1/16W	NN05000610	RA52		nsp	CHIP 0Ω ±5% 1/16W	NN05000610
R879	/N	nsp	CHIP 0Ω ±5% 1/16W	NN05000610	RA53		nsp	CHIP 0Ω ±5% 1/16W	NN05000610
R880	/N	nsp	CHIP 0Ω ±5% 1/16W	NN05000610					
R881	/N	nsp	CHIP 22kΩ ±5% 1/16W	NN05223610	RB01	/N	nsp	CHIP 68Ω ±5% 1/16W	NN05680610
R882	/N	nsp	CHIP 1kΩ ±5% 1/16W	NN05102610	RB03	/N	nsp	CHIP 100Ω ±5% 1/16W	NN05101610
R883	/N	nsp	CHIP 56kΩ ±5% 1/16W	NN05563610	RB04	/N	nsp	CHIP 1.8kΩ ±5% 1/16W	NN05182610
R884	/N	nsp	CHIP 220Ω ±5% 1/16W	NN05221610	RB05		nsp	CHIP 390Ω ±5% 1/16W	NN05391610
R885	/N	nsp	CHIP 220Ω ±5% 1/16W	NN05221610	RB06		nsp	CHIP 22kΩ ±5% 1/16W	NN05223610
R886	/N	nsp	CHIP 220Ω ±5% 1/16W	NN05221610	RB07		nsp	CHIP 2.2kΩ ±5% 1/16W	NN05222610
R887	/N	nsp	CHIP 4.7kΩ ±5% 1/16W	NN05472610	RB08	/A/C/F		CHIP 0Ω ±5% 1/16W	NN05000610
R888	/N	nsp	CHIP 4.7kΩ ±5% 1/16W	NN05472610		/L/S/U			
R889	/N	nsp	CHIP 56kΩ ±5% 1/16W	NN05563610	RB08	/N	nsp	CHIP 3.3kΩ ±5% 1/16W	NN05332610
R890	/N	nsp	CHIP 1.5kΩ ±5% 1/16W	NN05152610	RB09	/N	nsp	CHIP 5.6kΩ ±5% 1/16W	NN05562610
R891	/N	nsp	CHIP 1.5kΩ ±5% 1/16W	NN05152610	RB10		nsp	CHIP 33Ω ±5% 1/16W	NN05330610
R892	/N	nsp	CHIP 1.5kΩ ±5% 1/16W	NN05152610	RB11		nsp	CHIP 27Ω ±5% 1/16W	NN05270610
					RB12	/A/C/F		CHIP 33Ω ±5% 1/16W	NN05330610
						/L/S			
RA01		nsp	FERRITE CORE CHIP	FC90020110	RB13	/A/C/F		CHIP 27Ω ±5% 1/16W	NN05270610
			BLM11B601S			/L/S/U			
RA03		nsp	FERRITE CORE CHIP	FC90020110	RB23	/N	nsp	CHIP 0Ω ±5% 1/16W	NN05000610
			BLM11B601S		RB25	/A/C/F		CHIP 0Ω ±5% 1/16W	NN05000610
						/L/S/U			
RA04					RC01	/N	nsp	CHIP 68Ω ±5% 1/16W	NN05680610
RA05		nsp	CHIP 0Ω ±5% 1/16W	NN05000610	RC03	/N	nsp	CHIP 100Ω ±5% 1/16W	NN05101610
RA06		nsp	CHIP 0Ω ±5% 1/16W	NN05000610	RC04	/N	nsp	CHIP 1.8kΩ ±5% 1/16W	NN05182610
RA07					RC05		nsp	CHIP 390Ω ±5% 1/16W	NN05391610
RA08		nsp	CHIP 2.2kΩ ±5% 1/16W	NN05222610	RC06		nsp	CHIP 22kΩ ±5% 1/16W	NN05223610
RA09		nsp	CHIP 2.2kΩ ±5% 1/16W	NN05222610	RC07		nsp	CHIP 2.2kΩ ±5% 1/16W	NN05222610
RA10		nsp	CHIP 10kΩ ±5% 1/16W	NN05103610	RC08	/A/C/F		CHIP 0Ω ±5% 1/16W	NN05000610
RA12		nsp	CHIP 0Ω ±5% 1/16W	NN05000610		/L/S/U			
RA13		nsp	CHIP 100Ω ±5% 1/16W	NN05101610	RC08	/N	nsp	CHIP 3.3kΩ ±5% 1/16W	NN05332610
RA14		nsp	CHIP 680Ω ±5% 1/16W	NN05681610	RC09	/N	nsp	CHIP 5.6kΩ ±5% 1/16W	NN05562610
RA15		nsp	CHIP 1.5kΩ ±5% 1/16W	NN05152610	RC10		nsp	CHIP 33Ω ±5% 1/16W	NN05330610
RA16		nsp	CHIP 47Ω ±5% 1/16W	NN05470610	RC11		nsp	CHIP 27Ω ±5% 1/16W	NN05270610
			CHIP 6.8kΩ ±5% 1/16W	NN05682610	RC12	/A/C/F		CHIP 33Ω ±5% 1/16W	NN05330610
RA-23		nsp	CHIP 6.8kΩ ±5% 1/16W	NN05682610		/L/S			
RA-25		nsp	CHIP 1.5kΩ ±5% 1/16W	NN05152610	RC13	/A/C/F		CHIP 27Ω ±5% 1/16W	NN05270610
RA-26		nsp	CHIP 47Ω ±5% 1/16W	NN05470610		/L/S/U			
RA-27		nsp	CHIP 0Ω ±5% 1/16W	NN05000610	RC23	/N	nsp	CHIP 0Ω ±5% 1/16W	NN05000610
					RC25	/A/C/F		CHIP 0Ω ±5% 1/16W	NN05000610
RA-28		nsp	CHIP 10kΩ ±5% 1/16W	NN05103610		/L/S/U			
RA-29					RD01		nsp	CHIP 0Ω ±5% 1/16W	NN05000610
RA30		nsp	CHIP 10kΩ ±5% 1/16W	NN05103610	RD02		nsp	CHIP 0Ω ±5% 1/16W	NN05000610
RA31		nsp	CHIP 10kΩ ±5% 1/16W	NN05103610	RD03		nsp	CHIP 0Ω ±5% 1/16W	NN05000610
RA32		nsp	CHIP 680Ω ±5% 1/16W	NN05681610	RD11		nsp	CHIP 0Ω ±5% 1/16W	NN05000610

NOTE : "nsp" PART IS LISTED FOR REFERENCE ONLY, MARANTZ WILL NOT SUPPLY THESE PARTS.

POS. NO	VERS. COLOR	PART NO. (FOR EUR)	DESCRIPTION	PART NO. (MJ)	POS. NO	VERS. COLOR	PART NO. (FOR EUR)	DESCRIPTION	PART NO. (MJ)
RD21		nsp	CHIP 0Ω ±5% 1/16W	NN05000610	RE81		nsp	CHIP 10kΩ ±5% 1/16W	NN05103610
RD22		nsp	CHIP 0Ω ±5% 1/16W	NN05000610	RE82		nsp	CHIP 10kΩ ±5% 1/16W	NN05103610
RD23		nsp	CHIP 0Ω ±5% 1/16W	NN05000610	RE83		nsp	CHIP 10kΩ ±5% 1/16W	NN05103610
RD31		nsp	CHIP 0Ω ±5% 1/16W	NN05000610	RE84		nsp	CHIP 0Ω ±5% 1/16W	NN05000610
RD41		nsp	CHIP 0Ω ±5% 1/16W	NN05000610					
RD42		nsp	CHIP 0Ω ±5% 1/16W	NN05000610	RG01				
RD43		nsp	CHIP 0Ω ±5% 1/16W	NN05000610	}	nsp	CHIP 100Ω ±5% 1/16W	NN05101610	
RD51		nsp	CHIP 0Ω ±5% 1/16W	NN05000610	RG23				
					RI03		nsp	CHIP 0Ω ±5% 1/16W	NN05000610
RE01					RI04		nsp	CHIP 2.2kΩ ±5% 1/16W	NN05222610
}		nsp	CHIP 0Ω ±5% 1/16W	NN05000610	RI05		nsp	CHIP 1.8kΩ ±5% 1/16W	NN05182610
RE11					RI06		nsp	CHIP 3.9kΩ ±5% 1/16W	NN05392610
RE12					RI07		nsp	CHIP 220Ω ±5% 1/16W	NN05221610
}		nsp	CHIP 22Ω ±5% 1/16W	NN05220610	RI08		nsp	CHIP 68Ω ±5% 1/16W	NN05680610
RE18					RI09		nsp	CHIP 100kΩ ±5% 1/16W	NN05104610
RE19					RI10		nsp	CHIP 0Ω ±5% 1/16W	NN05000610
RE20					RI14		nsp	CHIP 220Ω ±5% 1/16W	NN05221610
}		nsp	CHIP 0Ω ±5% 1/16W	NN05000610	RI16		nsp	CHIP 0Ω ±5% 1/16W	NN05000610
RE33					RI17		nsp	CHIP 0Ω ±5% 1/16W	NN05000610
RE34					RI21		nsp	CHIP 22Ω ±5% 1/16W	NN05220610
RE35		BW05000320	RES.COMPO. 0Ω X 4 J CN1J KOA	BW05000320	RI31				
					}	nsp	CHIP 10kΩ ±5% 1/16W	NN05103610	
RE38		nsp	CHIP 0Ω ±5% 1/16W	NN05000610	RI34				
RE39		BW05000320	RES.COMPO. 0Ω X 4 J CN1J KOA	BW05000320	RI35		nsp	CHIP 0Ω ±5% 1/16W	NN05000610
RE43		nsp	CHIP 0Ω ±5% 1/16W	NN05000610	RV01		nsp	CHIP 10kΩ ±5% 1/16W	NN05103610
RE44		nsp	CHIP 0Ω ±5% 1/16W	NN05000610	RV02		nsp	CHIP 3.3kΩ ±5% 1/16W	NN05332610
RE45		nsp	CHIP 0Ω ±5% 1/16W	NN05000610	RV03		nsp	CHIP 3.3kΩ ±5% 1/16W	NN05332610
RE46		nsp	FERRITE CORE CHIP BLM11B601S	FC90020110	RV04		nsp	CHIP 3.3kΩ ±5% 1/16W	NN05332610
					RV05	/A/C/F /L/S/U		CHIP 470Ω ±5% 1/16W	NN05471610
RE49	/A/C/F /L/S/U		CHIP 1.2kΩ ±5% 1/16W	NN05122610					
					RV05	/N	nsp	CHIP 680Ω ±5% 1/16W	NN05681610
RE49	/N	nsp	CHIP 2.2kΩ ±5% 1/16W	NN05222610	RV06	/A/C/F /L/S/U		CHIP 470Ω ±5% 1/16W	NN05471610
RE50		nsp	CHIP 8.2kΩ ±5% 1/16W	NN05822610	RV06	/N	nsp	CHIP 560Ω ±5% 1/16W	NN05561610
RE51	/A/C/F /L/S/U		CHIP 4.7kΩ ±5% 1/16W	NN05472610	RV07		nsp	CHIP 100Ω ±5% 1/16W	NN05101610
					RV08		nsp	CHIP 1.8kΩ ±5% 1/16W	NN05182610
RE51	/N	nsp	CHIP 10kΩ ±5% 1/16W	NN05103610	RV09		nsp	CHIP 680Ω ±5% 1/16W	NN05681610
RE52		nsp	CHIP 330Ω ±5% 1/16W	NN05331610	RV10		nsp	CHIP 22kΩ ±5% 1/16W	NN05223610
RE53		nsp	CHIP 0Ω ±5% 1/16W	NN05000610	RV11		nsp	CHIP 2.2kΩ ±5% 1/16W	NN05222610
RE54		nsp	CHIP 0Ω ±5% 1/16W	NN05000610	RV12	/A/C/F /L/S/U		CHIP 470Ω ±5% 1/16W	NN05471610
RE55		nsp	FERRITE CORE CHIP BLM11B601S	FC90020110					
					RV12	/N	nsp	CHIP 680Ω ±5% 1/16W	NN05681610
RE56		BW05000320	RES.COMPO. 0Ω X 4 J CN1J KOA	BW05000320	RV13	/A/C/F /L/S/U		CHIP 470Ω ±5% 1/16W	NN05471610
RE57		nsp	CHIP 0Ω ±5% 1/16W	NN05000610	RV13	/N	nsp	CHIP 560Ω ±5% 1/16W	NN05561610
RE58		nsp	CHIP 0Ω ±5% 1/16W	NN05000610	RV14		nsp	CHIP 100Ω ±5% 1/16W	NN05101610
RE59		BW05000320	RES.COMPO. 0Ω X 4 J CN1J KOA	BW05000320	RV15		nsp	CHIP 1.8kΩ ±5% 1/16W	NN05182610
					RV16		nsp	CHIP 680Ω ±5% 1/16W	NN05681610
RE60		nsp	CHIP 0Ω ±5% 1/16W	NN05000610	RV17		nsp	CHIP 22kΩ ±5% 1/16W	NN05223610
RE61		nsp	CHIP 0Ω ±5% 1/16W	NN05000610	RV18		nsp	CHIP 2.2kΩ ±5% 1/16W	NN05122610
RE62		nsp	CHIP 0Ω ±5% 1/16W	NN05000610	RV19	/A/C/F /L/S/U		CHIP 470Ω ±5% 1/16W	NN05471610
RE63		BW05000320	RES.COMPO. 0Ω X 4 J CN1J KOA	BW05000320					
					RV19	/N	nsp	CHIP 680Ω ±5% 1/16W	NN05681610
RE64		nsp	CHIP 0Ω ±5% 1/16W	NN05000610	RV20	/A/C/F /L/S/U		CHIP 470Ω ±5% 1/16W	NN05471610
RE65		nsp	CHIP 0Ω ±5% 1/16W	NN05000610					
RE66		nsp	CHIP 0Ω ±5% 1/16W	NN05000610	RV20	/N	nsp	CHIP 560Ω ±5% 1/16W	NN05561610
RE70					RV21		nsp	CHIP 100Ω ±5% 1/16W	NN05101610
}		nsp	CHIP 0Ω ±5% 1/16W	NN05000610	RV22		nsp	CHIP 1.8kΩ ±5% 1/16W	NN05182610
RE74					RV23		nsp	CHIP 680Ω ±5% 1/16W	NN05681610
RE75		nsp	CHIP 22kΩ ±5% 1/16W	NN05223610	RV24		nsp	CHIP 22kΩ ±5% 1/16W	NN05223610
RE76		nsp	CHIP 75Ω ±5% 1/16W	NN05750610	RV25		nsp	CHIP 2.2kΩ ±5% 1/16W	NN05222610
RE77		nsp	FERRITE CORE CHIP BLM11B601S	FC90020110	RV26		nsp	CHIP 1.2kΩ ±5% 1/16W	NN05122610
					RV27		nsp	CHIP 3.9kΩ ±5% 1/16W	NN05392610
RE78		BW05103320	RES.COMPO. 10kΩ X 4 J CN1J KOA	BW05103320	RV28	/A/C/F /L/S/U		CHIP 0Ω ±5% 1/16W	NN05000610
RE79		BW05103320	RES.COMPO. 10kΩ X 4 J CN1J KOA	BW05103320	RV29	/N	nsp	CHIP 0Ω ±5% 1/16W	NN05000610
					RV30		nsp	CHIP 0Ω ±5% 1/16W	NN05000610
RE80		BW05103320	RES.COMPO. 10kΩ X 4 J CN1J KOA	BW05103320	RV31		nsp	CHIP 0Ω ±5% 1/16W	NN05000610
					RV32		nsp	CHIP 10kΩ ±5% 1/16W	NN05103610

NOTE : "nsp" PART IS LISTED FOR REFERENCE ONLY, MARANTZ WILL NOT SUPPLY THESE PARTS.

POS. NO	VERS. COLOR	PART NO. (FOR EUR)	DESCRIPTION	PART NO. (MJJ)	POS. NO	VERS. COLOR	PART NO. (FOR EUR)	DESCRIPTION	PART NO. (MJJ)
RV33		nsp	CHIP 47Ω ±5% 1/16W	NN05470610	Q206	/N	nsp	CHIP TRS. 2SC4213	HX342132A0
RV34		nsp	CHIP 15Ω ±5% 1/16W	NN05150610	Q207		BA20035210	DIG.TRS. DTC114EU	BA20035210
RV35		nsp	CHIP 47Ω ±5% 1/16W	NN05470610	Q208		BA20035210	DIG.TRS. DTC114EU	BA20035210
RV36		nsp	CHIP 15Ω ±5% 1/16W	NN05150610	Q209		nsp	CHIP TRS. 2SA1586 Y GR	HX100012A0
RV37		nsp	CHIP 33Ω ±5% 1/16W	NN05330610				2SA1576A Q R	
RV38		nsp	CHIP 27Ω ±5% 1/16W	NN05270610	Q231		HF201701H0	F.E.T. 2SK170 V LANK	HF201701H0
RV39		nsp	CHIP 33Ω ±5% 1/16W	NN05330610	Q232		nsp	F.E.T. 2SJ74 V LANK	HF100741H0
RV40		nsp	CHIP 27Ω ±5% 1/16W	NN05270610	Q234		nsp	CHIP TRS. 2SC4213	HX342132A0
RV41		nsp	CHIP 0Ω ±5% 1/16W	NN05000610	Q236	/N	nsp	CHIP TRS. 2SC4213	HX342132A0
RV43		nsp	CHIP 0Ω ±5% 1/16W	NN05000610	Q237		BA20035210	DIG.TRS. DTC114EU	BA20035210
RV45		nsp	CHIP 0Ω ±5% 1/16W	NN05000610	Q238		BA20035210	DIG.TRS. DTC114EU	BA20035210
RV47		nsp	CHIP 10kΩ ±5% 1/16W	NN05103610	Q239		nsp	CHIP TRS. 2SA1586 Y GR	HX100012A0
RV48		nsp	CHIP 10kΩ ±5% 1/16W	NN05103610				2SA1576A Q R	
RV50		nsp	CHIP 1.2kΩ ±5% 1/16W	NN05122610					
RV51		nsp	CHIP 1.2kΩ ±5% 1/16W	NN05122610	Q301		nsp	F.E.T. 2SK389 GR OR BL	HF203892A0
RV52		nsp	CHIP 1.2kΩ ±5% 1/16W	NN05122610	Q303		nsp	CHIP TRS. 2SC2873 Y	HX328731B0
					Q304		nsp	CHIP TRS. 2SA1312 B	HX113121B0
RY01	/N	nsp	CHIP 68Ω ±5% 1/16W	NN05680610	Q305		nsp	CHIP TRS. 2SA1312 B	HX113121B0
RY03	/N	nsp	CHIP 100Ω ±5% 1/16W	NN05101610	Q306		nsp	CHIP TRS. 2SC3324 B	HX333241B0
RY04	/N	nsp	CHIP 1.8kΩ ±5% 1/16W	NN05182610	Q311		nsp	F.E.T. 2SK389 GR OR BL	HF203892A0
RY05		nsp	CHIP 390Ω ±5% 1/16W	NN05391610	Q313		nsp	CHIP TRS. 2SC2873 Y	HX328731B0
RY06		nsp	CHIP 22kΩ ±5% 1/16W	NN05223610	Q314		nsp	CHIP TRS. 2SA1312 B	HX113121B0
RY07		nsp	CHIP 2.2kΩ ±5% 1/16W	NN05222610	Q315		nsp	CHIP TRS. 2SA1312 B	HX113121B0
RY08		nsp	CHIP 0Ω ±5% 1/16W	NN05000610	Q316		nsp	CHIP TRS. 2SC3324 B	HX333241B0
RY10	/N/U	nsp	CHIP 0Ω ±5% 1/16W	NN05000610	Q321		nsp	F.E.T. 2SK389 GR OR BL	HF203892A0
RY11		nsp	CHIP 1.2kΩ ±5% 1/16W	NN05122610	Q323		nsp	CHIP TRS. 2SC2873 Y	HX328731B0
RY12		nsp	CHIP 3.9kΩ ±5% 1/16W	NN05392610	Q324		nsp	CHIP TRS. 2SA1312 B	HX113121B0
RY14		nsp	CHIP 0Ω ±5% 1/16W	NN05000610	Q325		nsp	CHIP TRS. 2SA1312 B	HX113121B0
RY15		nsp	CHIP 0Ω ±5% 1/16W	NN05000610	Q326		nsp	CHIP TRS. 2SC3324 B	HX333241B0
RY16		nsp	CHIP 0Ω ±5% 1/16W	NN05000610	Q331		nsp	F.E.T. 2SK389 GR OR BL	HF203892A0
RY17		nsp	CHIP 33Ω ±5% 1/16W	NN05330610	Q333		nsp	CHIP TRS. 2SC2873 Y	HX328731B0
RY18		nsp	CHIP 27Ω ±5% 1/16W	NN05270610	Q334		nsp	CHIP TRS. 2SA1312 B	HX113121B0
RY19	/A/C/F /L/S		CHIP 10kΩ ±5% 1/16W	NN05103610	Q335		nsp	CHIP TRS. 2SA1312 B	HX113121B0
RY20	/A/C/F /L/S		CHIP 10kΩ ±5% 1/16W	NN05103610	Q336		nsp	CHIP TRS. 2SC3324 B	HX333241B0
RY21	/A/C/F /L/S		CHIP 33Ω ±5% 1/16W	NN05330610	Q341		nsp	F.E.T. 2SK389 GR OR BL	HF203892A0
RY22	/A/C/F /L/S		CHIP 27Ω ±5% 1/16W	NN05270610	Q343		nsp	CHIP TRS. 2SC2873 Y	HX328731B0
RY23	/N	nsp	CHIP 0Ω ±5% 1/16W	NN05000610	Q344		nsp	CHIP TRS. 2SA1312 B	HX113121B0
RY25	/A/C/F /L/S/U		CHIP 0Ω ±5% 1/16W	NN05000610	Q345		nsp	CHIP TRS. 2SA1312 B	HX113121B0
					Q346		nsp	CHIP TRS. 2SC3324 B	HX333241B0
					Q351		nsp	F.E.T. 2SK389 GR OR BL	HF203892A0
					Q353		nsp	CHIP TRS. 2SC2873 Y	HX328731B0
					Q354		nsp	CHIP TRS. 2SA1312 B	HX113121B0
					Q355		nsp	CHIP TRS. 2SA1312 B	HX113121B0
					Q356		nsp	CHIP TRS. 2SC3324 B	HX333241B0
			<b>PM01-SEMICONDUCTORS</b>						
D200		HZ21005000	CHIP DIODE 1SS301 DAN202U	HZ21005000	Q401		HF201701H0	F.E.T. 2SK170 V LANK	HF201701H0
D221		HZ21005000	CHIP DIODE 1SS301 DAN202U	HZ21005000	Q402		nsp	F.E.T. 2SJ74 V LANK	HF100741H0
D251		HZ21005000	CHIP DIODE 1SS301 DAN202U	HZ21005000	Q404		nsp	CHIP TRS. 2SC4213	HX342132A0
D301		HZ20007210	CHIP DIODE IMN10 ARRAY	HZ20007210	Q407		BA20035210	DIG.TRS. DTC114EU	BA20035210
D302		HZ20018050	CHIP DIODE 1SS302	HZ20018050	Q408		BA20035210	DIG.TRS. DTC114EU	BA20035210
D311		HZ20007210	CHIP DIODE IMN10 ARRAY	HZ20007210	Q409		nsp	CHIP TRS. 2SA1586 Y GR	HX100012A0
D312		HZ20018050	CHIP DIODE 1SS302	HZ20018050				2SA1576A Q R	
D321		HZ20007210	CHIP DIODE IMN10 ARRAY	HZ20007210	Q431		HF201701H0	F.E.T. 2SK170 V LANK	HF201701H0
D322		HZ20018050	CHIP DIODE 1SS302	HZ20018050	Q432		nsp	F.E.T. 2SJ74 V LANK	HF100741H0
D331		HZ20007210	CHIP DIODE IMN10 ARRAY	HZ20007210	Q434		nsp	CHIP TRS. 2SC4213	HX342132A0
D332		HZ20018050	CHIP DIODE 1SS302	HZ20018050	Q437		BA20035210	DIG.TRS. DTC114EU	BA20035210
D341		HZ20007210	CHIP DIODE IMN10 ARRAY	HZ20007210	Q438		BA20035210	DIG.TRS. DTC114EU	BA20035210
D342		HZ20018050	CHIP DIODE 1SS302	HZ20018050	Q439		nsp	CHIP TRS. 2SA1586 Y GR	HX100012A0
D351		HZ20007210	CHIP DIODE IMN10 ARRAY	HZ20007210				2SA1576A Q R	
D352		HZ20018050	CHIP DIODE 1SS302	HZ20018050	Q501		HF201701H0	F.E.T. 2SK170 V LANK	HF201701H0
D421		HZ21005000	CHIP DIODE1SS301 DAN202U	HZ21005000	Q502		nsp	F.E.T. 2SJ74 V LANK	HF100741H0
D451		HZ21005000	CHIP DIODE1SS301 DAN202U	HZ21005000	Q504		nsp	CHIP TRS. 2SC4213	HX342132A0
D521		HZ21005000	CHIP DIODE1SS301 DAN202U	HZ21005000	Q507		BA20035210	DIG.TRS. DTC114EU	BA20035210
D551		HZ21005000	CHIP DIODE1SS301 DAN202U	HZ21005000	Q508		BA20035210	DIG.TRS. DTC114EU	BA20035210
DV01		HZ30034050	CHIP DIODE 01ZA8.2	HZ30034050	Q509		nsp	CHIP TRS. 2SA1586 Y GR	HX100012A0
DV02		HZ30034050	CHIP DIODE 01ZA8.2	HZ30034050				2SA1576A Q R	
Q201		HF201701H0	F.E.T. 2SK170 V LANK	HF201701H0	Q531		HF201701H0	F.E.T. 2SK170 V LANK	HF201701H0
Q202		nsp	F.E.T. 2SJ74 V LANK	HF100741H0	Q532		nsp	F.E.T. 2SJ74 V LANK	HF100741H0
Q204		nsp	CHIP TRS. 2SC4213	HX342132A0	Q534		nsp	CHIP TRS. 2SC4213	HX342132A0
					Q537		BA20035210	DIG.TRS. DTC114EU	BA20035210

NOTE : \*nsp\* PART IS LISTED FOR REFERENCE ONLY, MARANTZ WILL NOT SUPPLY THESE PARTS.

POS. NO	VERS. COLOR	PART NO. (FOR EUR)	DESCRIPTION	PART NO. (MJI)	POS. NO	VERS. COLOR	PART NO. (FOR EUR)	DESCRIPTION	PART NO. (MJI)
Q538 Q539		BA20035210 nsp	DIG.TR.S. DTC114EU CHIP TRS. 2SA1586 Y GR 2SA1576A Q R	BA20035210 HX100012A0	QY04		HC10406030	IC LA7138M VIDEO AMP FOR DVD	HC10406030
Q852	/N	nsp	CHIP TRS. 2SA1586 Y GR 2SA1576A Q R	HX100012A0	F221 F251 J203	/N /N	nsp nsp YT02041050	<b>PM01-MISCELLANEOUS</b> CHIP 0Ω ±5% 1/16W CHIP 0Ω ±5% 1/16W TERMINAL 14X14 RA 2L4P W/R AU FRNT-GND	NN05000610 NN05000610 YT02041050
Q853	/N	HC10101550	IC MM1509XN VIDEO DRIVER CLAMP	HC10101550	J205 J206 J209 JI01		YT02041170 YL01010320 YL01010320 YT02021640	TERMINAL YKC21-3778 TERMINAL M1698-A NEJI TERMINAL M1698-A NEJI TERMINAL 14X14 RA 1L2P ORG NI F-GROUND	YT02041170 YL01010320 YL01010320 YT02021640
Q855	/N	nsp	CHIP TRS. 2SA1586 Y GR 2SA1576A Q R	HX100012A0	JI03 JI04		YT02011030 YJ15000210	TERMINAL YKC21-3707 OPT. CONNECTOR OUTPUT JFJ300	YT02011030 YJ15000210
Q856	/N	HC10101550	IC MM1509XN VIDEO DRIVER CLAMP	HC10101550	JV01		YT02021630	TERMINAL 14X14 RA 1L2P YEL AU F-SHIELD	YT02021630
Q858	/N	nsp	CHIP TRS. 2SA1586 Y GR 2SA1576A Q R	HX100012A0	JV02 JY01		YJ11000670 YT02030580	JACK YKC51-5527 TERMINAL 3P CINCH PIN JACK YKC21-4010	YJ11000670 YT02030580
Q859	/N	HC10099550	IC MM1506XN VIDEO SW 6DB AMP	HC10099550	JY02	/A/C/F /L/S	JACK YK45-3007 D CONNECTOR GOLD	YJ11000680	YJ11000680
Q860	/N	HC10100550	IC MM1508XN VIDEO SW CLAMP	HC10100550	L851 L852	/N /N	LC11233900 LC11533900	CHOKE COIL 12UH EL0405 CHOKE COIL SUBSTITUTE 15μH J%	LC11233900 LC11533900
Q861	/N	HC10101550	IC MM1509XN VIDEO DRIVER CLAMP	HC10101550	L852	/N	LC11533900	CHOKE COIL SUBSTITUTE 15μH J%	LC11533900
Q862	/N	BA20035210	DIG.TR.S. DTC114EU	BA20035210	L853 L854	/N /N	LC11233900 LC11533900	CHOKE COIL 12UH EL0405 CHOKE COIL SUBSTITUTE 15μH J%	LC11233900 LC11533900
Q863	/N	nsp	CHIP TRS. 2SA1586 Y GR 2SA1576A Q R	HX100012A0	L855 L856	/N /N	LC11233900 LC11533900	CHOKE COIL 12UH EL0405 CHOKE COIL SUBSTITUTE 15μH J%	LC11233900 LC11533900
Q864	/N	BA20035210	DIG.TR.S. DTC114EU	BA20035210	LA01		LC11033900	CHOKE COIL SUBSTITUTE 10μH J%	LC11033900
Q865	/N	HX300012A0	CHIP TRS. 2SC4081 Q R 2SC4116 Y GR	HX300012A0	LB01 LB02		LC14723900 LC15623900	CHOKE COIL 4.7UH EL0405 CHOKE COIL SUBSTITUTE 5.6μH J%	LC14723900 LC15623900
QA01 QA02		HC10085840 nsp	IC ADV7300 VIDEO ENCODER CHIP TRS. 2SA1586 Y GR 2SA1576A Q R	HC10085840 HX100012A0	LB03 LB04		nsp	CHIP 0Ω ±5% 1/16W CHIP 0Ω ±5% 1/16W	NN05000610 NN05000610
QA03		nsp	CHIP TRS. 2SA1586 Y GR 2SA1576A Q R	HX100012A0	LC01 LC02		nsp nsp	CHOKE COIL 4.7UH EL0405 CHOKE COIL SUBSTITUTE 5.6μH J%	LC14723900 LC15623900
QA04		nsp	CHIP TRS. 2SA1586 Y GR 2SA1576A Q R	HX100012A0	LC03 LC04		nsp	CHIP 0Ω ±5% 1/16W CHIP 0Ω ±5% 1/16W	NN05000610 NN05000610
QB01	/N	nsp	CHIP TRS. 2SA1586 Y GR 2SA1576A Q R	HX100012A0	LD01	/A/C/F /L/S/U	nsp	FERRITE CORE CHIP BLM11B601S	FC90020110
QB02		nsp	CHIP TRS. 2SA1586 Y GR 2SA1576A Q R	HX100012A0	LE01		LC11033900	CHOKE COIL SUBSTITUTE 10μH J%	LC11033900
QC01	/N	nsp	CHIP TRS. 2SA1586 Y GR 2SA1576A Q R	HX100012A0	LI01		nsp	FERRITE CORE CHIP BLM11B601S	FC90020110
QC02		nsp	CHIP TRS. 2SA1586 Y GR 2SA1576A Q R	HX100012A0	LI31 LI34 LI35		nsp nsp nsp	CHIP 0Ω ±5% 1/16W FERRITE CORE CHIP BLM11B601S	NN05000610 FC90020110 FC90020110
QD01 QD21		HC10013880 HC10013880	IC CS4392 24BIT 192KHZ DAC IC CS4392 24BIT 192KHZ DAC	HC10013880 HC10013880	LV01		nsp	CHOKE COIL SUBSTITUTE 6.8μH J%	LC14723900
QD41		HC10013880	IC CS4392 24BIT 192KHZ DAC	HC10013880	LV02		LC14723900	CHOKE COIL 4.7UH EL0405	LC14723900
QE01		HC10018660	IC PM0033A PROGRESSIVE	HC10018660	LV03		nsp	CHOKE COIL SUBSTITUTE 10μH J%	LC11033900
QE02		HC10001910	IC K4S643232E-TC60 64MBIT SDRAM	HC10001910	LV04 LV05		LC14723900 LC11033900	CHOKE COIL 4.7UH EL0405 CHOKE COIL SUBSTITUTE 10μH J%	LC14723900 LC11033900
▲ QE03		HC98J25210	IC BA25BC0FP +2.5V REG.	HC98J25210	LV06		LC14723900	CHOKE COIL 4.7UH EL0405	LC14723900
QE04		BA20035210	DIG.TR.S. DTC114EU	BA20035210					
QE05		BA20035210	DIG.TR.S. DTC114EU	BA20035210					
QI03		HX300012A0	CHIP TRS. 2SC4081 Q R 2SC4116 Y GR	HX300012A0					
QV01 QV02		HC98510030 HX117971A0	IC REG IC L88MS05T-FA CHIP TRS. 2SA1797	HC98510030 HX117971A0					
QV03		BA20035210	DIG.TR.S. DTC114EU	BA20035210					
QV04 }		nsp	CHIP TRS. 2SA1586 Y GR 2SA1576A Q R	HX100012A0					
QV09		nsp	CHIP TRS. 2SA1162 0 Y	HX111622A0					
QV10		HC10406030	IC LA7138M VIDEO AMP FOR DVD	HC10406030					
QV11		HC10406030	IC LA7138M VIDEO AMP FOR DVD	HC10406030					
QV12		HX300012A0	CHIP TRS. 2SC4081 Q R 2SC4116 Y GR	HX300012A0					
QY01	/N	nsp	CHIP TRS. 2SA1586 Y GR 2SA1576A Q R	HX100012A0					
QY02		nsp	CHIP TRS. 2SA1586 Y GR 2SA1576A Q R	HX100012A0					
QY03		nsp	CHIP TRS. 2SA1162 0 Y	HX111622A0					

NOTE : "nsp" PART IS LISTED FOR REFERENCE ONLY, MARANTZ WILL NOT SUPPLY THESE PARTS.





POS. NO	VERS. COLOR	PART NO. (FOR EUR)	DESCRIPTION	PART NO. (MJJ)	POS. NO	VERS. COLOR	PART NO. (FOR EUR)	DESCRIPTION	PART NO. (MJJ)
DP63		HZ21005000	CHIP DIODE 1SS301 DAN202U	HZ21005000				<b>PS02-POWER SWITCH CIRCUIT BOARD</b>	
DP64		HZ30007020	CHIP DIODE ZENER 5.6V MA8056L	HZ30007020	▲ SP01		SP01013800		SP01013800
▲ QP01		HF22943000	F.E.T. 2SK2943 900V 3A	HF22943000				<b>PS02-POWER SWITCH CIRCUIT BOARD</b> PUSH SWITCH MAINS POWER ESB92S17B	
QP02		HC10006130	IC FA3647 PWM CONTROL IC	HC10006130					
▲ QP03		nsp	PHOTO UNIT PC-123F2	HW10032320					
QP04		HC33036590	PHOTO COUPLER IC TL431CZ	HC33036590					
QP05		HT316272B0	PROG.VOLTAGE REFERENCE TRS. 2SC1627 O Y 80V 300MA 600MW TO	HT316272B0					
▲ QP06		HC36903320	IC PQ3RF33 +3.3V 3.5A	HC36903320					
▲ QP07		HC10006080	IC SI-3050C +5V 1.5A SW	HC10006080					
▲ QP08		HC36912080	IC SI-3120F +12V 1A WITH SW	HC36912080					
QP09		HT30001000	TRS. C2458 C1740S C3199 ETC.	HT30001000					
QP50		BA20035210	DIG.TRS. DTC114EU	BA20035210					
QP51		BA10026210	DIG.TRS. DTA114EU	BA10026210					
QP52		HX300012A0	CHIP TRS. 2SC4081 Q R	HX300012A0					
		nsp	2SC4116 Y GR						
QP53		nsp	TRS. 2SD1762 E F	HT417622B0					
QP54		HT214531A0	TRS. 2SB1453 NEC	HT214531A0					
▲ QP55		HC38505090	IC NJM78M05FA	HC38505090					
QP56		HX300012A0	CHIP TRS. 2SC4081 Q R	HX300012A0					
		nsp	2SC4116 Y GR						
QP57		HX300012A0	CHIP TRS. 2SC4081 Q R	HX300012A0					
		nsp	2SC4116 Y GR						
QP58		HX300012A0	CHIP TRS. 2SC4081 Q R	HX300012A0					
		nsp	2SC4116 Y GR						
QP59		nsp	CHIP TRS. 2SA1586 Y GR	HX100012A0					
		nsp	2SA1576A Q R						
QP60		BA21311000	DIG.TRS. RN1311 DTC114TU	BA21311000					
QP61		HX300012A0	CHIP TRS. 2SC4081 Q R	HX300012A0					
		nsp	2SC4116 Y GR						
QP62		nsp	CHIP TRS. 2SA1586 Y GR	HX100012A0					
		nsp	2SA1576A Q R						
▲ QP63		HC36103090	IC NJU7200L33 3.3V 0.1A	HC36103090					
			<b>PS01-MISCELLANEOUS</b>						
▲ FP01	/A/C/N	FS10200850	FUSE 2 A 250V BS LISTED	FS10200850					
	/S								
▲ FP01	/F/L/U		FUSE 2A 125V	FS10200350					
			UL CSA MITI TYPE FBT						
▲ FP02		FS20025200	FUSE T250MA 250V	FS20025200					
			TR5 NO.19372						
▲ FP03		FS20250200	FUSE T2.5A 250V	FS20250200					
			TR5 NO.19372						
▲ FP50		FS20050200	FUSE T500MA 250V	FS20050200					
			TR5 NO.19372						
▲ FP51		FS20050200	FUSE T500MA 250V	FS20050200					
			TR5 NO.19372						
LP01		nsp	CHOKE COIL 22mH x2	LC22260130					
			LINE FILTER						
LP03		LC14734500	CHOKE COIL RCH-110	LC14734500					
			47µH 2.5A						
LP50		nsp	CHOKE COIL SUBSTITUTE	LC11033900					
			10µH J%						
▲ TP01		TS12900080	MAINS TRANSF. SW ER28S	TS12900080					
▲ TP50	/A/C/N	TS14159030	MAINS TRANSF.	TS14159030					
	/S		PE4124 AUDIO N S C A						
▲ TP50	/F		MAINS TRANSF.	TS14159010					
			PE4124 AUDIO FOR F						
▲ TP50	/L/U		MAINS TRANSF.	TS14159020					
			PE4124 AUDIO FOR L U						

NOTE : "nsp" PART IS LISTED FOR REFERENCE ONLY, MARANTZ WILL NOT SUPPLY THESE PARTS.

# Service Manual

DB-VLD302

DVD Loader for MARANTZ

DVD Player : DV8300



## TABLE OF CONTENTS

SECTION	PAGE
2. DB-VLD302 (DVD Loader for MARANTZ)	
2.1 LOADING MECHANISM ASS'Y AND LOAB PCB ASS'Y .....	2-2
2.2 TRAVERSE MECHANISM ASS'Y.....	2-5

Please use this service manual with referring to the user guide ( D.F.U. ) without fail.  
修理の際は、必ず取扱説明書を準備し操作方法を確認の上作業を行ってください。

---

# marantz®

---

## DB-VLD302

## 2. 1 LOADING MECHANISM ASS'Y AND LOAB PCB ASS'Y

**Note :**



Refer to "Application of Lubricant".

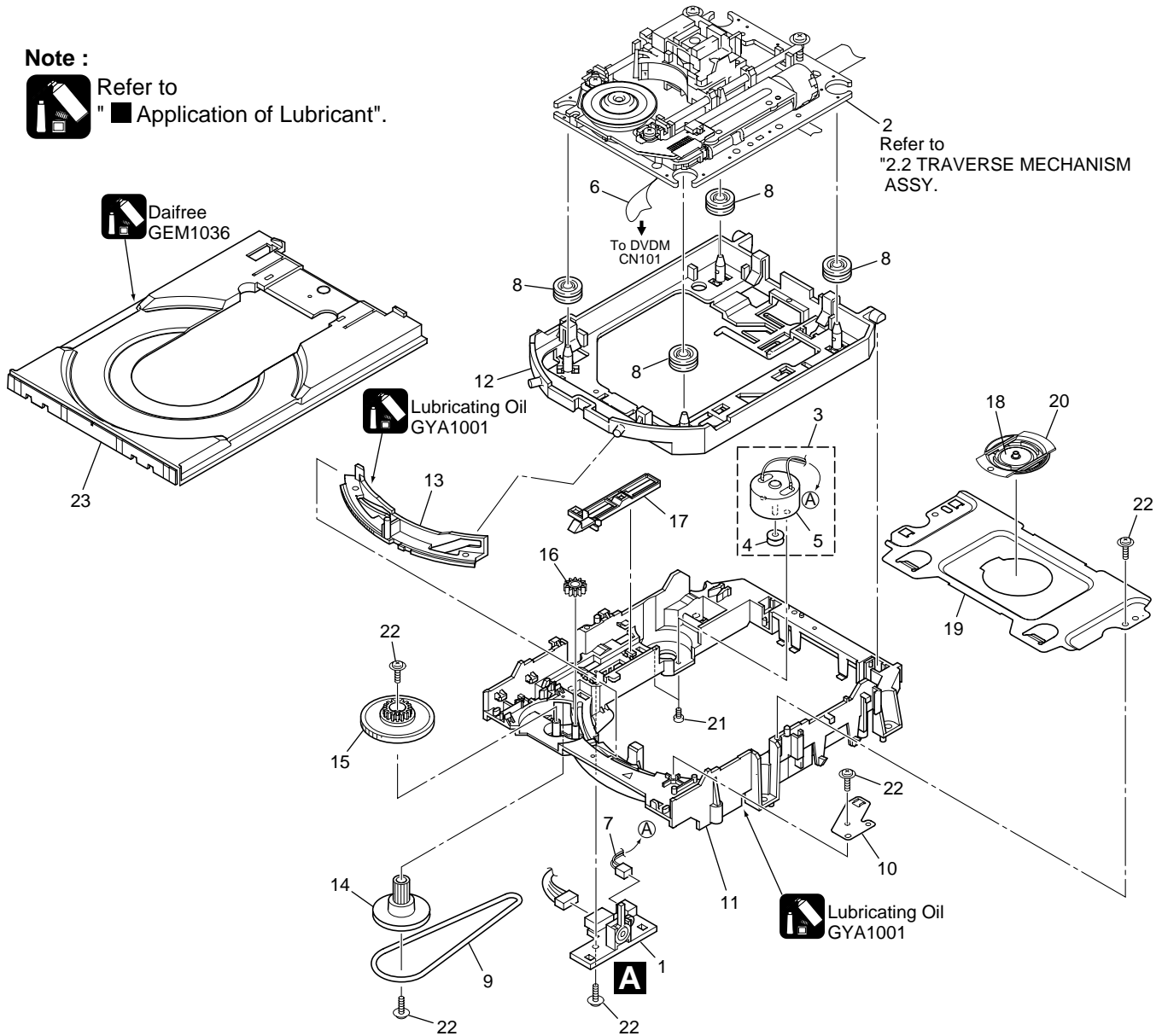

### A LOAB ASSY

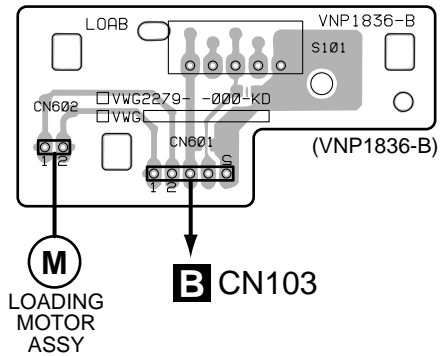

**SIDE A**

### A LOAB ASSY

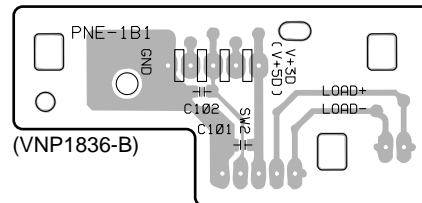

**SIDE B**

POS. NO	VERS. COLOR	PART NO. (FOR EUR)	PART NO. (MJ)	DESCRIPTION
				<b>LOADING MECHANISM ASSY</b>
1		nsp	nsp	LOAB Assy VVG2279
2		*ZK000340R	*ZK000340R	Traverse Mechanism Assy-S VXX2782
3		*ZZ001600R	*ZZ001600R	Loading Motor Assy VXX2505
4		02AK262010	02AK262010	Motor Pulley PNW1634
5		nsp	nsp	Carriage DC Motor / 0.3W PXM1027
6		*YU001000R	*YU001000R	Flexible Cable (26P) VDA1884
7		nsp	nsp	Connector Assy 2P VKP2253
8		02AK130010	02AK130010	Float Rubber VEB1327
9		02AK264010	02AK264010	Belt VEB1330
10		02AK002010	02AK002010	Stabilizer VNE2253
11		02AK105050	02AK105050	Loading Base VNL1917
12		02AK104010	02AK104010	Float Base DVD VNL1918
13		02AK054010	02AK054010	Drive Cam VNL1919
14		02AK262020	02AK262020	Gear Pulley VNL1921
15		02AK058010	02AK058010	Loading Gear VNL1922
16		02AK058020	02AK058020	Drive Gear VNL1923
17		02AK354010	02AK354010	SW Lever VNL1925
18		02AK104020	02AK104020	Clamper Plate VNE2251
19		02AK126010	02AK126010	Bridge VNE2252
20		02AK005010	02AK005010	Clamper VNL1924
21		nsp	nsp	Screw JGZ17P028FMC
22		nsp	nsp	Screw Z39-019
23		02AK163010	02AK163010	Tray VNL1920
				<b>LOAB ASSY</b>
S101		*SM000340R	*SM000340R	REAF SWITCH VSK1011
CN602		nsp	nsp	CONNECTOR S2B-PH-K
CN601		nsp	nsp	CONNECTOR S5B-PH-K
		nsp	nsp	PRINTED CIRCUIT BOARD VNP1836

NOTE : "nsp" PART IS LISTED FOR REFERENCE ONLY, MARANTZ WILL NOT SUPPLY THESE PARTS.

## Application of Lubricant

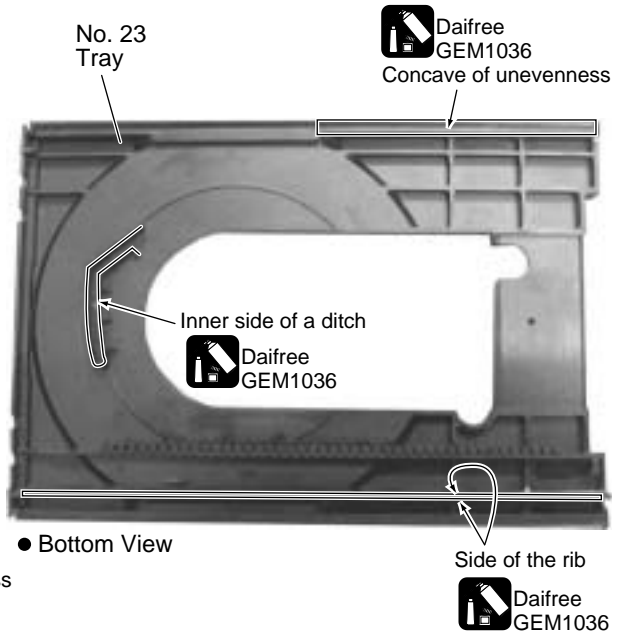
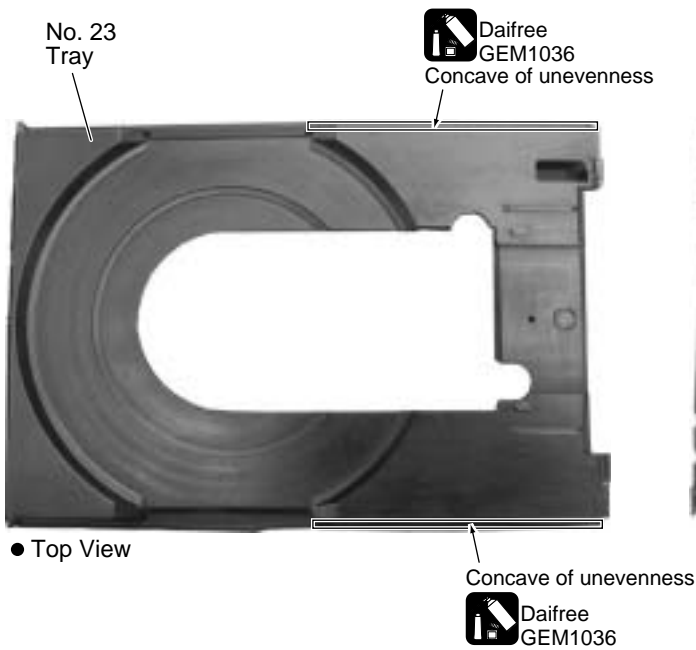
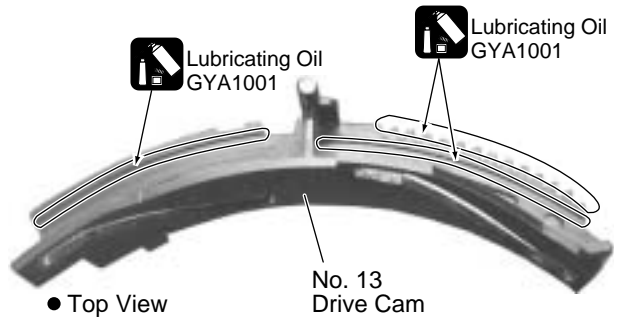
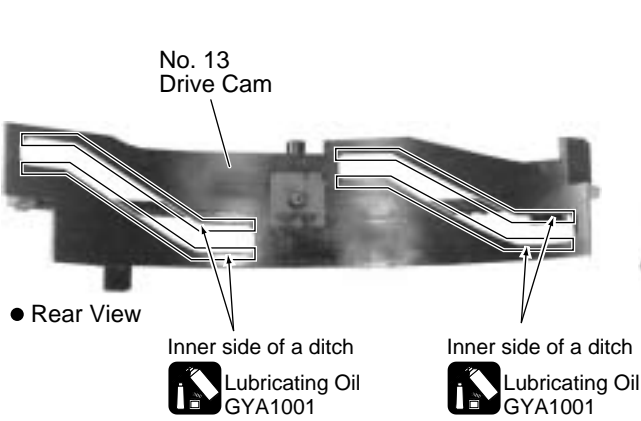
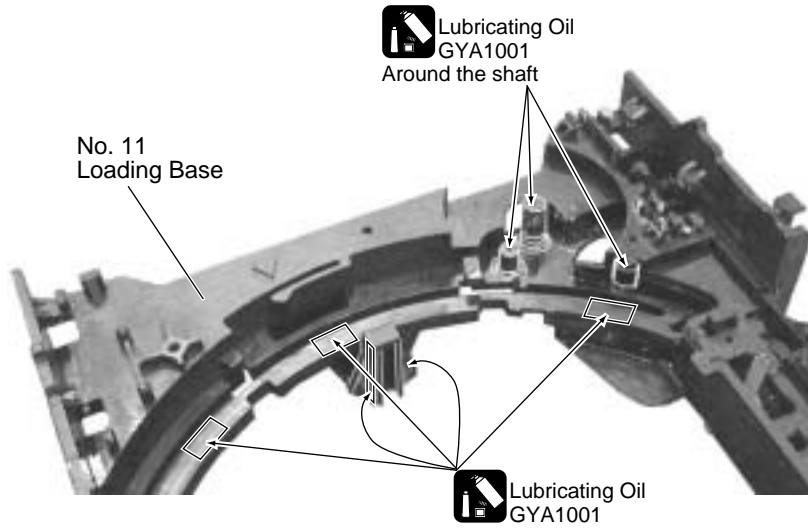

## 2. 2 TRAVERSE MECHANISM ASS'Y

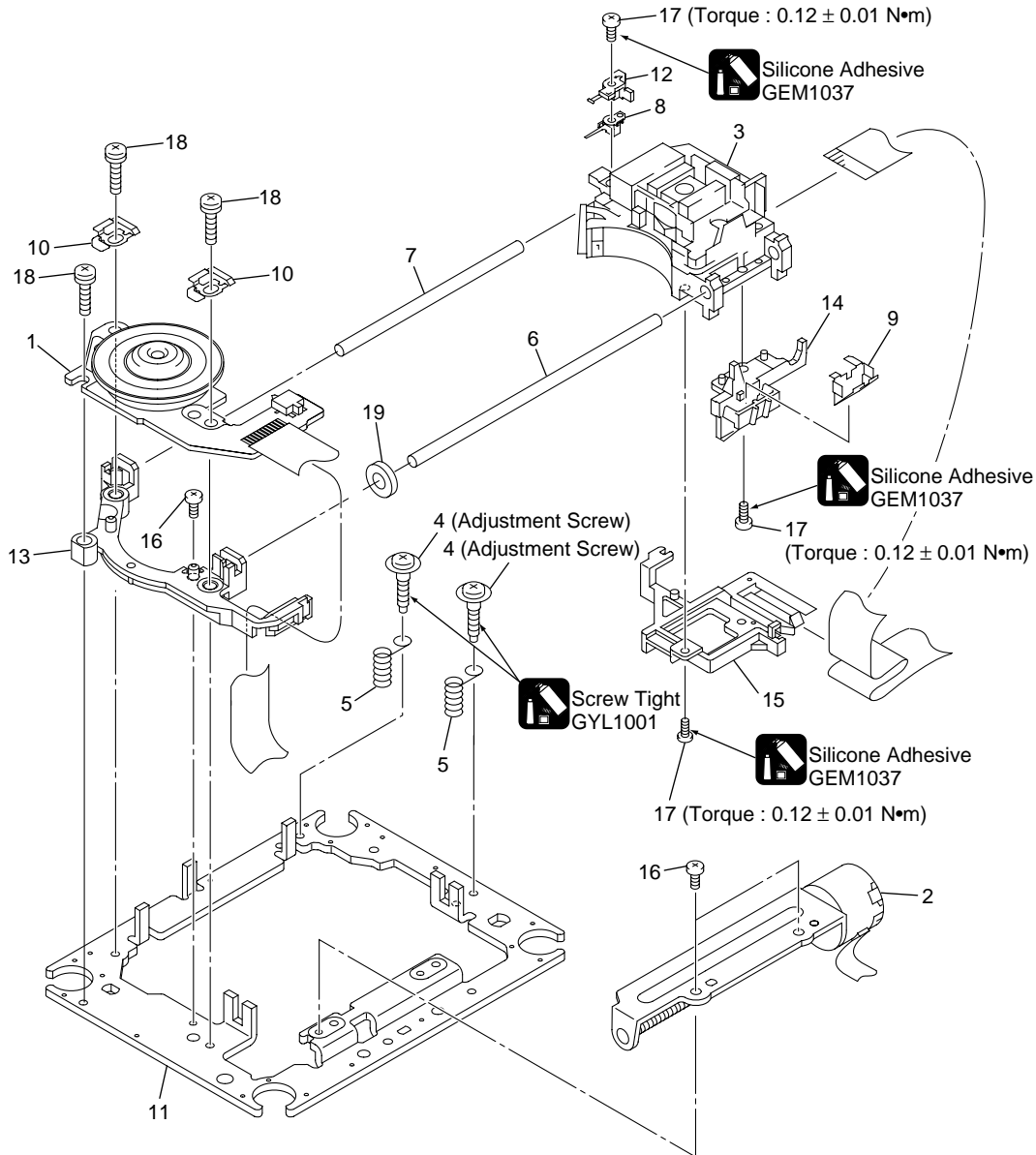

POS. NO	VERS. COLOR	PART NO. (FOR EUR)	PART NO. (MJI)	DESCRIPTION	
				<b>TRAVERSE MECHANISM ASSY (P/N : *ZK000340R )</b>	
1		nsp	nsp	Spindle Motor	VXM1089
2		nsp	nsp	Stepping Motor (CARRIAGE)	VXM1091
3		nsp	nsp	Pickup Assy-S	OXX8003
4		nsp	nsp	Skew Screw	VBA1080
5		nsp	nsp	Skew Spring	VBH1335
6		nsp	nsp	Guide Bar	VLL1514
7		nsp	nsp	Sub Guide Bar	VLL1515
8		nsp	nsp	Hold Spring	VNC1017
9		nsp	nsp	Joint Spring	VNC1019
10		nsp	nsp	Support Spring	VNC1020
11		nsp	nsp	Mechanism Chassis	VNE2248
12		nsp	nsp	Slider	VNL1811
13		nsp	nsp	Spacer	VNL1913
14		nsp	nsp	Joint	VNL1914
15		nsp	nsp	FFC Holder	VNL1915
16		nsp	nsp	Screw	BBZ20P050FZK
17		nsp	nsp	Screw	OBA8009
18		nsp	nsp	Screw	PMA26P100FMC
19		nsp	nsp	Damper Sheet	VEB1335

NOTE : \*nsp\* PART IS LISTED FOR REFERENCE ONLY, MARANTZ WILL NOT SUPPLY THESE PARTS.

# Service Manual

DB-VPB305

DVD PCB Module for MARANTZ

DVD Player : DV8300

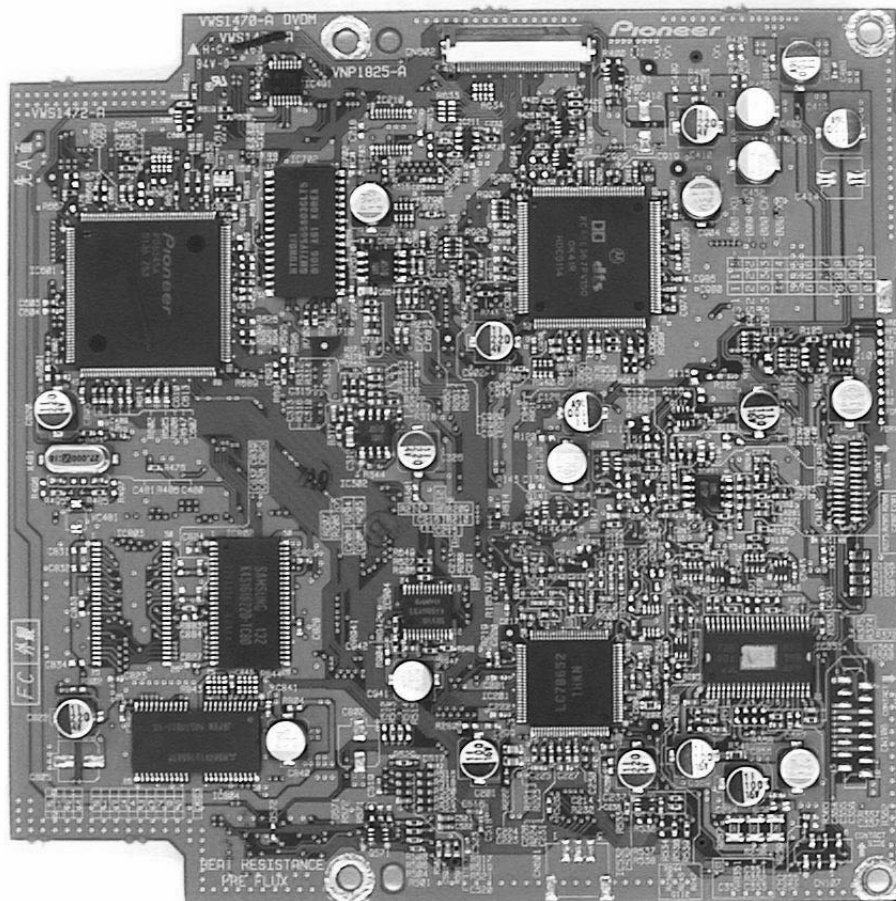

## TABLE OF CONTENTS

SECTION	PAGE
3. DB-VPB305 (DVD PCB Module for MARANTZ)	
3.1 DIAGRAMS (BLOCK, WIRING, SCHEMATIC, WAVEFORMS) .....	3-2
3.2 PCB CONNECTION DIAGRAM .....	3-15
3.3 GENERAL INFORMATION (ID NUMBER., DISASSEMBLY., IC DATA).....	3-18
3.4 PCB PARTS LIST.....	3-45

When you repair the DVDM PCB, please be sure to write down the ID number.

この基板（DVDM）を修理するときは必ずIDナンバーを書き留めておいて下さい。

Please use this service manual with referring to the user guide ( D.F.U. ) without fail.

修理の際は、必ず取扱説明書を準備し操作方法を確認の上作業を行ってください。

# marantz®

## DB-VPB305



### 3.1 BLOCK DIAGRAM AND SCHEMATIC DIAGRAM

#### BLOCK DIAGRAM

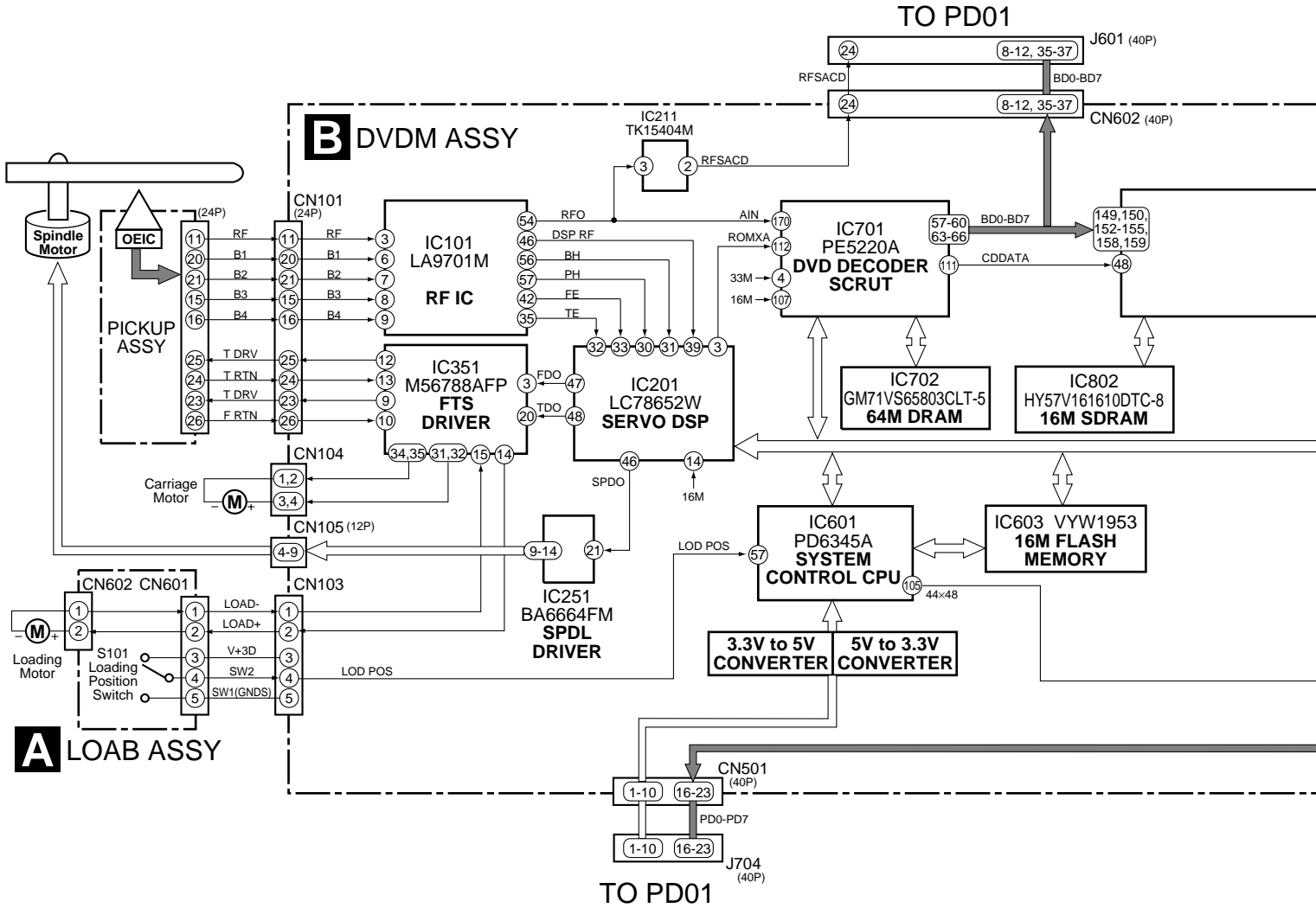

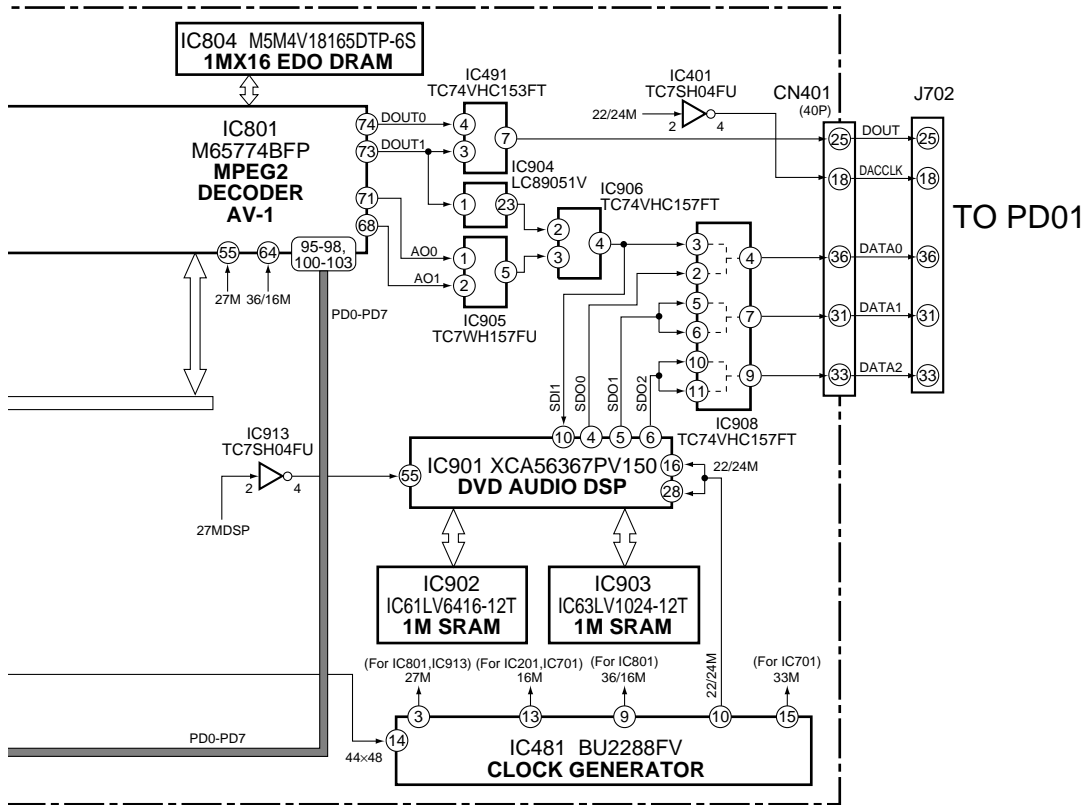

# AUDIO DATA STREAM (ANALOG OUTPUT)

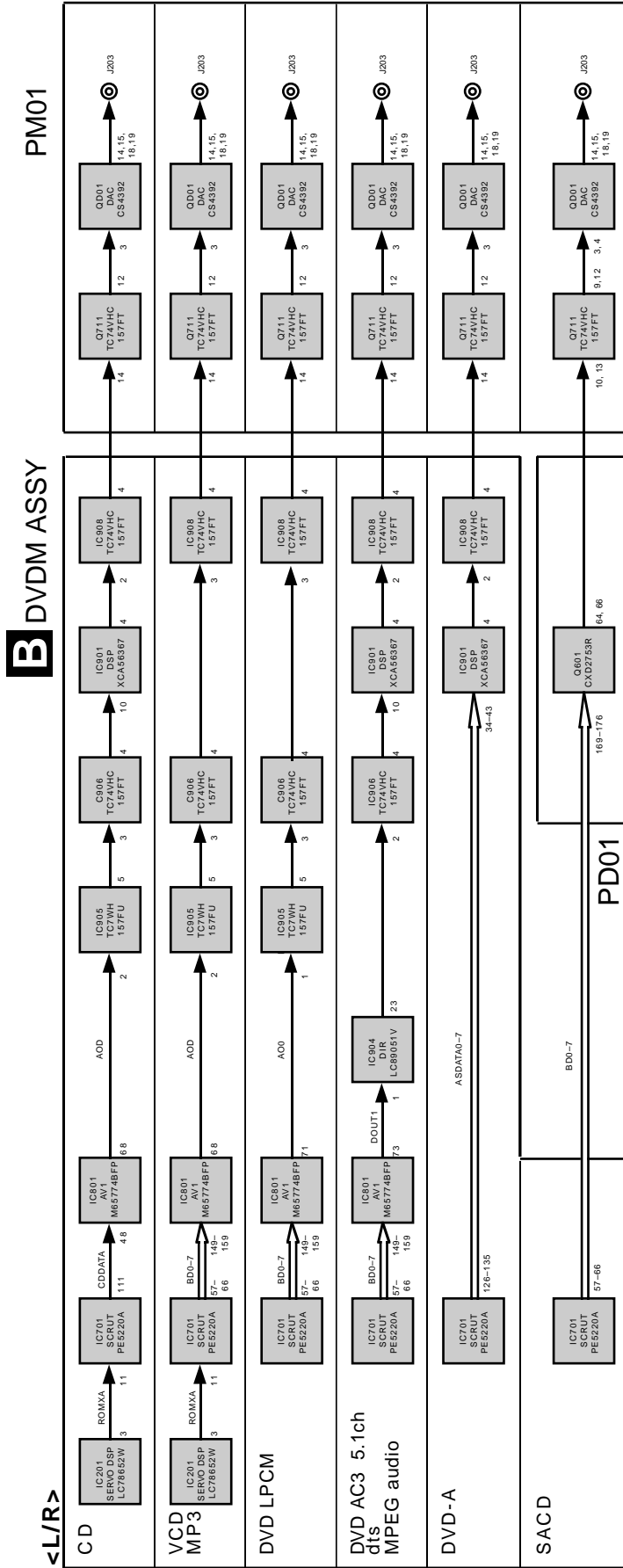

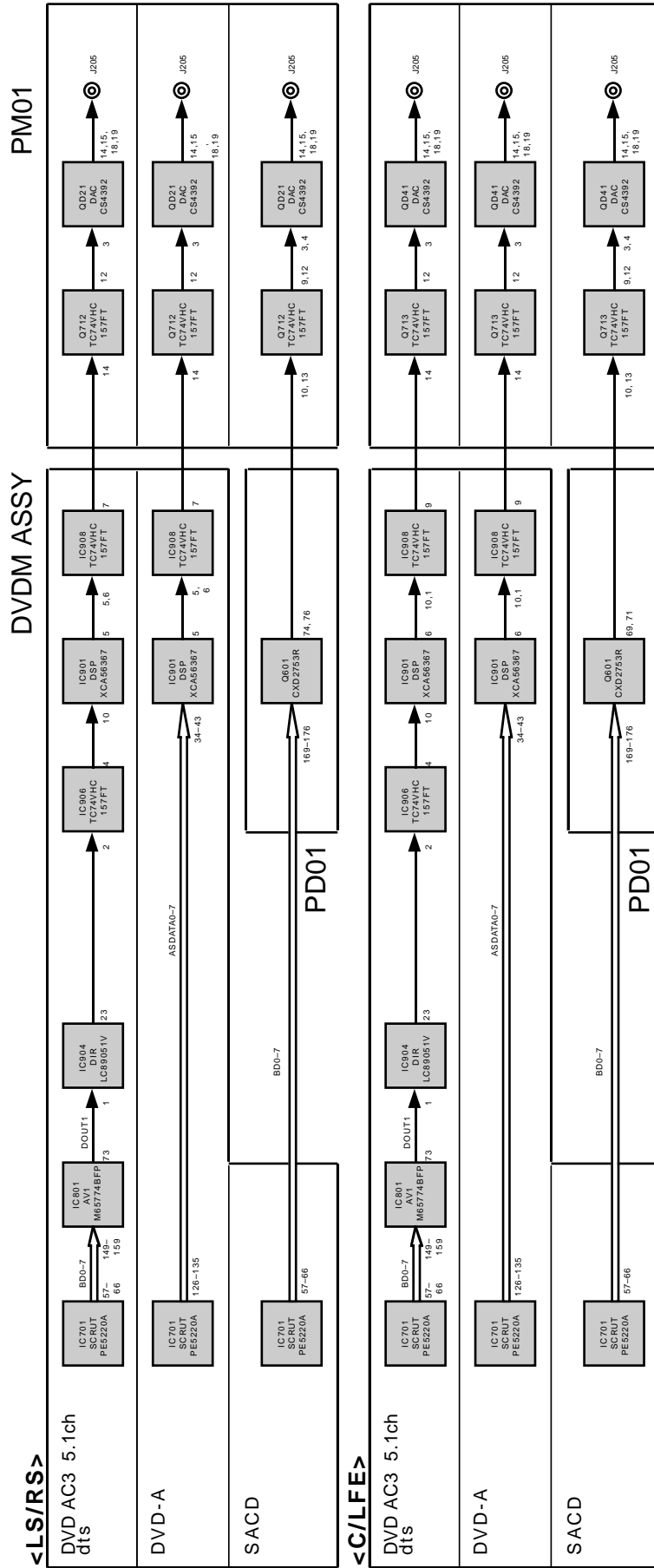

# AUDIO DATA STREAM (COAXIAL/OPTICAL OUTPUT)

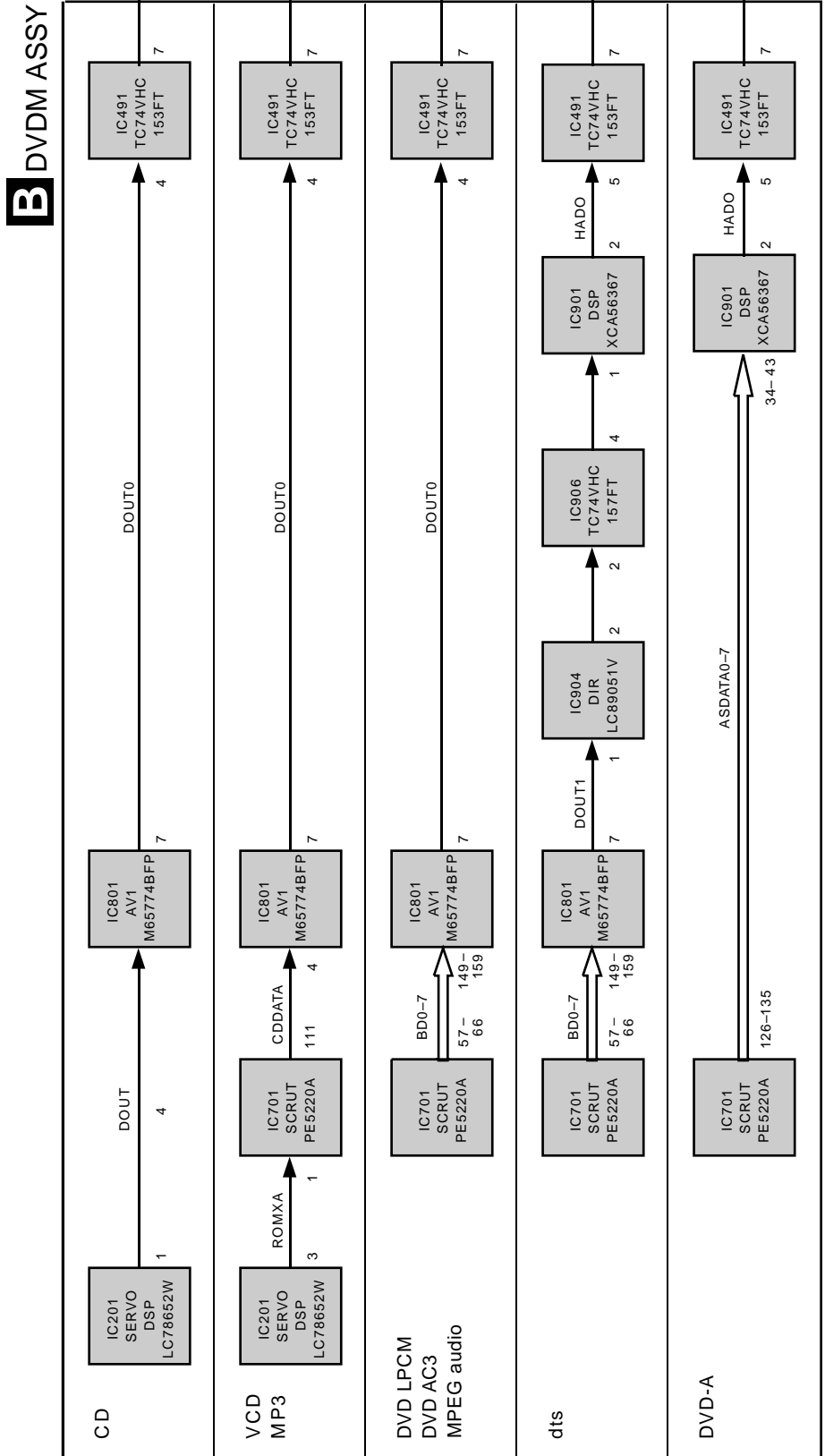

# SCHEMATIC DIAGRAM

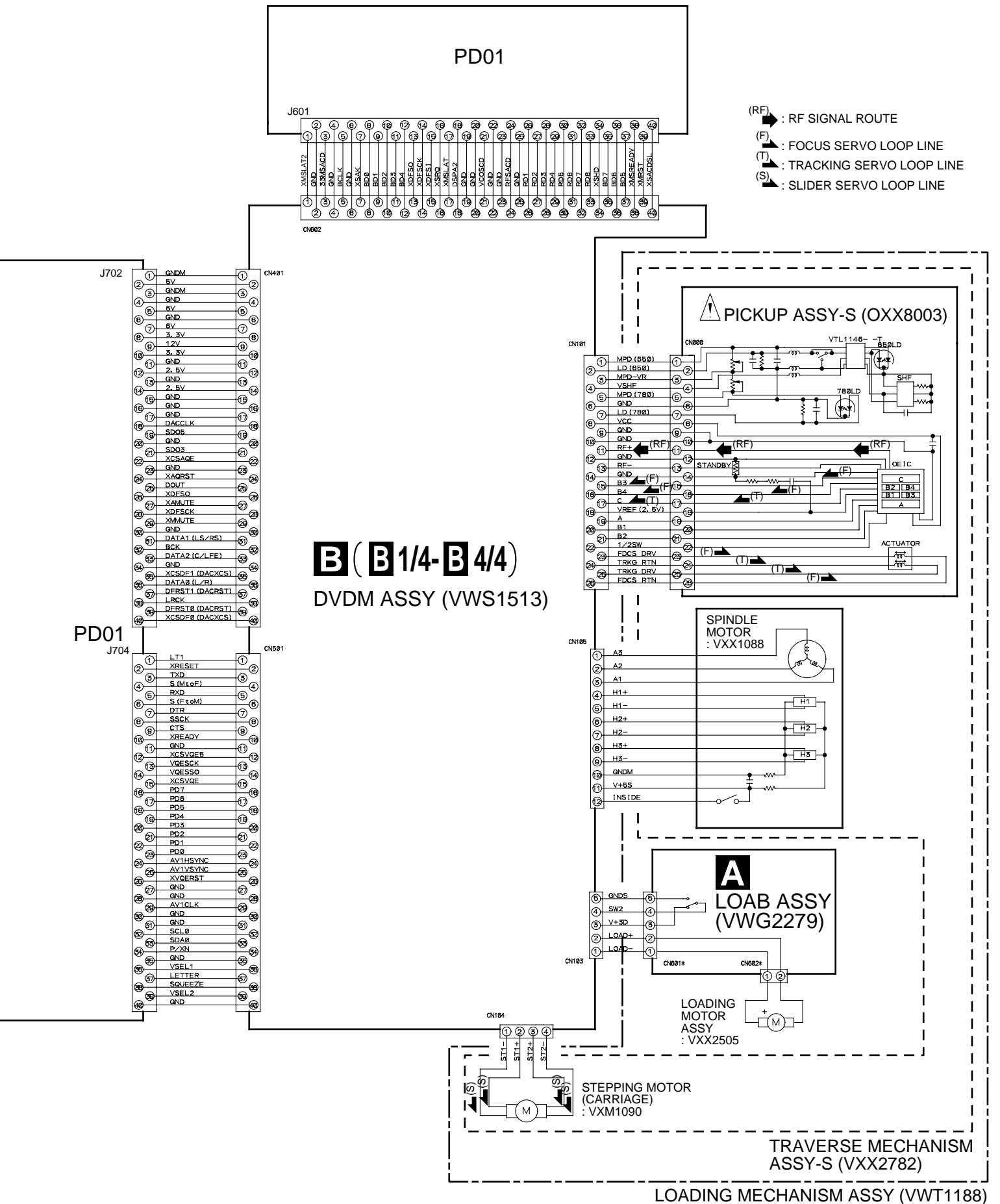

DVDM ASSY (1/4)

B 1/4 DVDM ASSY (VWS1513)

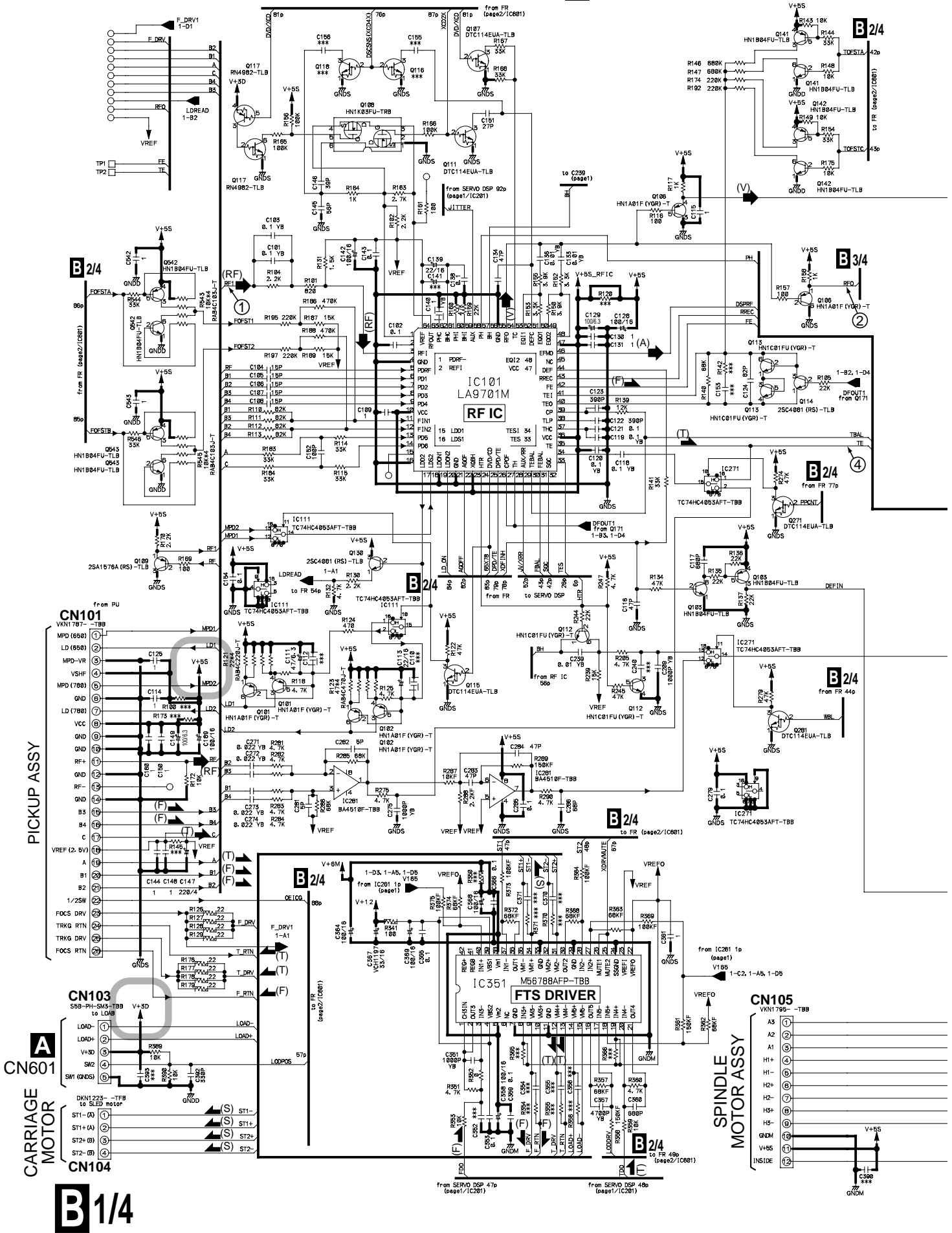

**O** : The power supply is shown with the marked box.

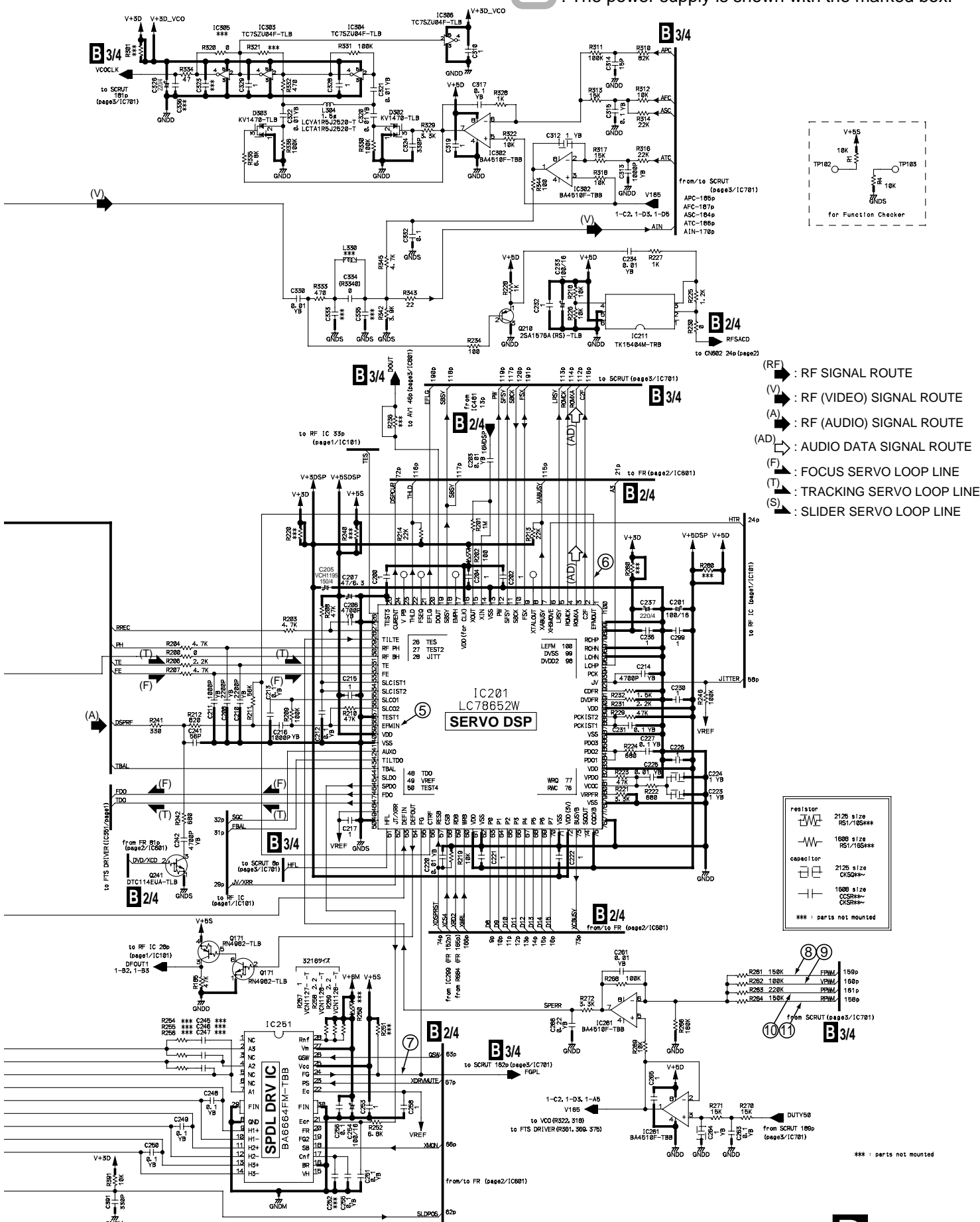

**B1/4**



DVDM ASSY (2/4)

**B** 2/4 DVDM ASSY (VWS1513)

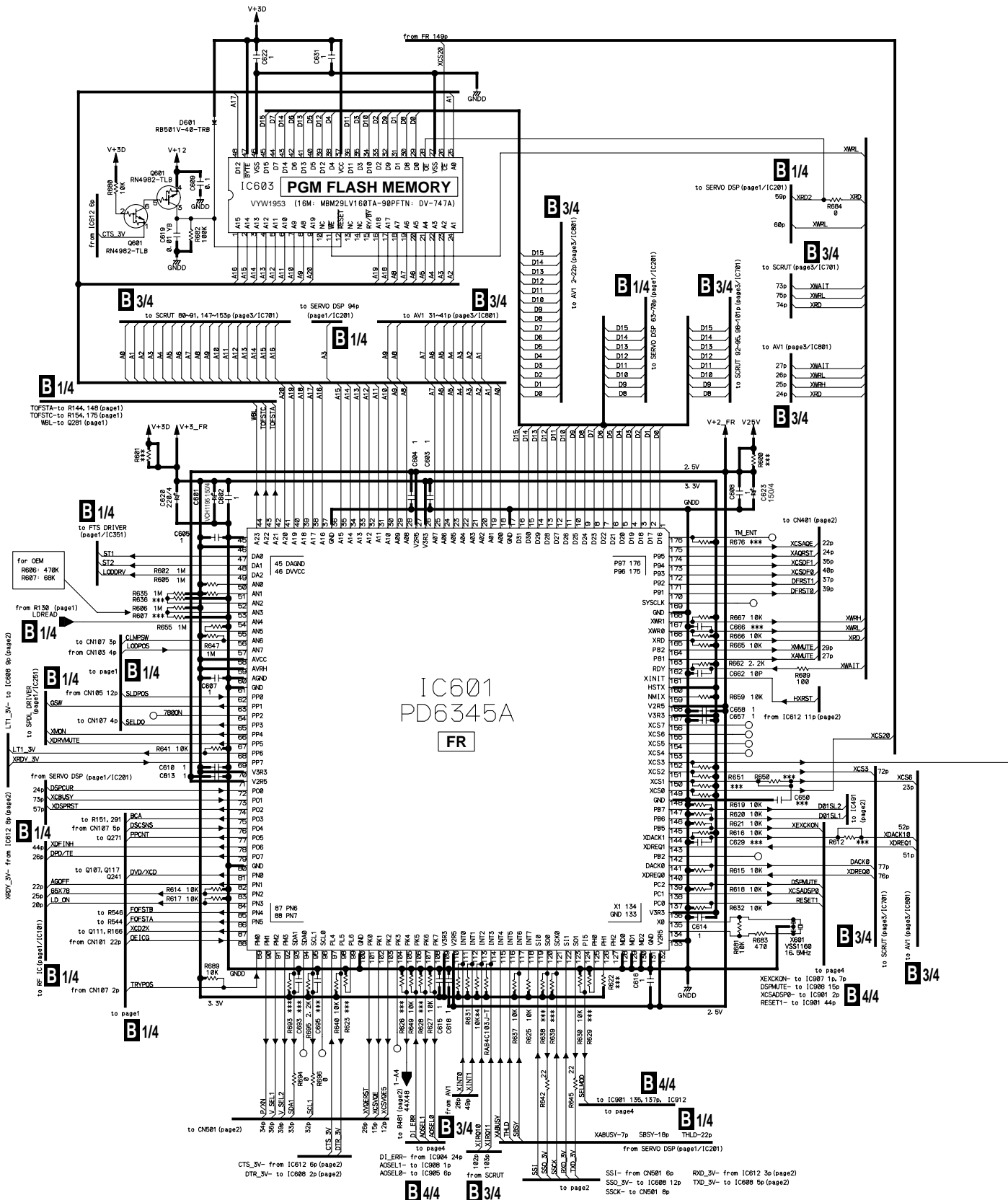

**B** 2/4

 : The power supply is shown with the marked box.

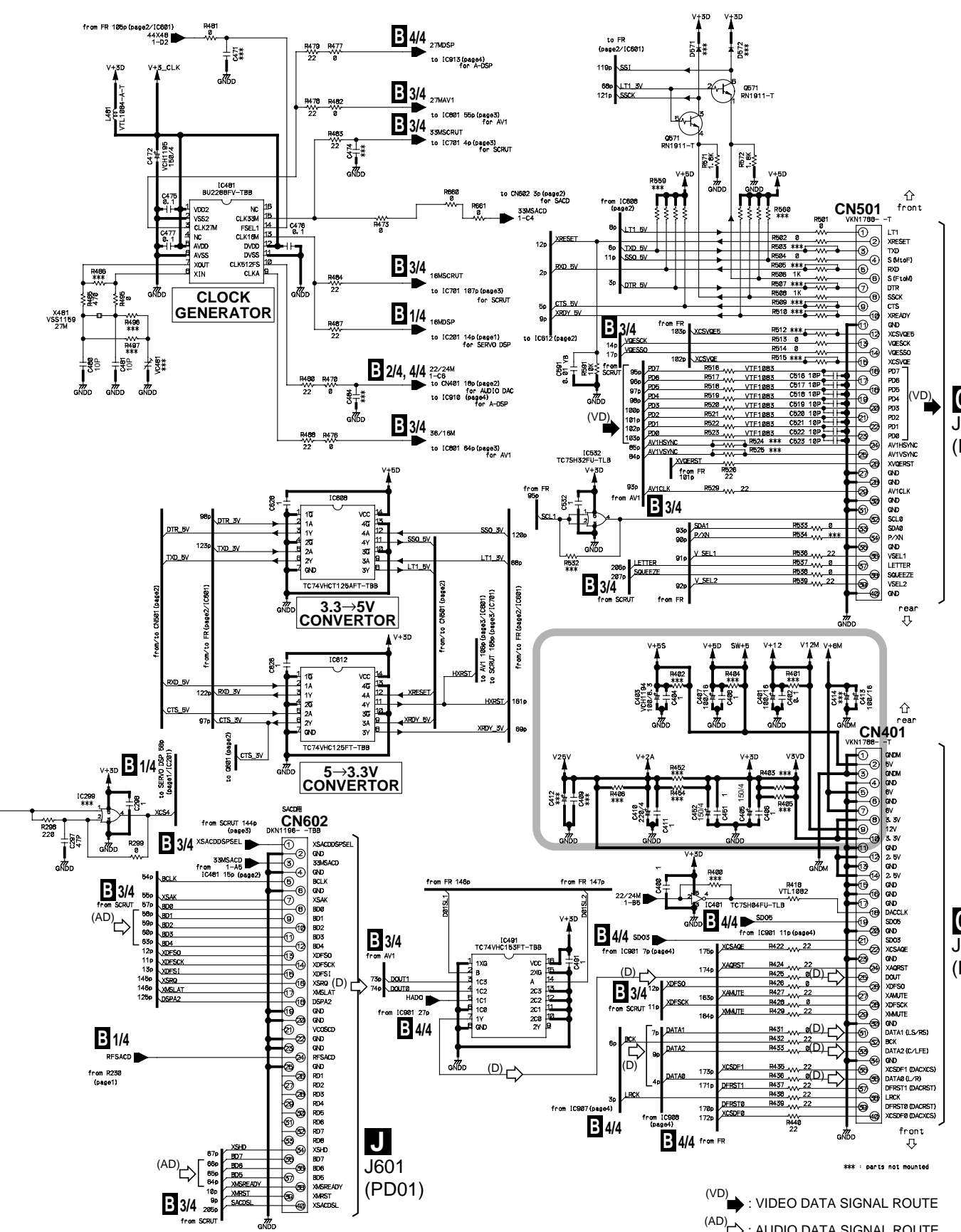

**G2/3**  
J704  
(PD01)

**C1/3**  
J702  
(PD01)

**J**  
J601  
(PD01)

- (VD) ➔ : VIDEO DATA SIGNAL ROUTE
- (AD) ➔ : AUDIO DATA SIGNAL ROUTE
- (D) ➔ : AUDIO (DIGITAL) SIGNAL ROUTE

# B2/4

# DVDM ASSY (3/4)

## B 3/4 DVDM ASSY (VWS1513)

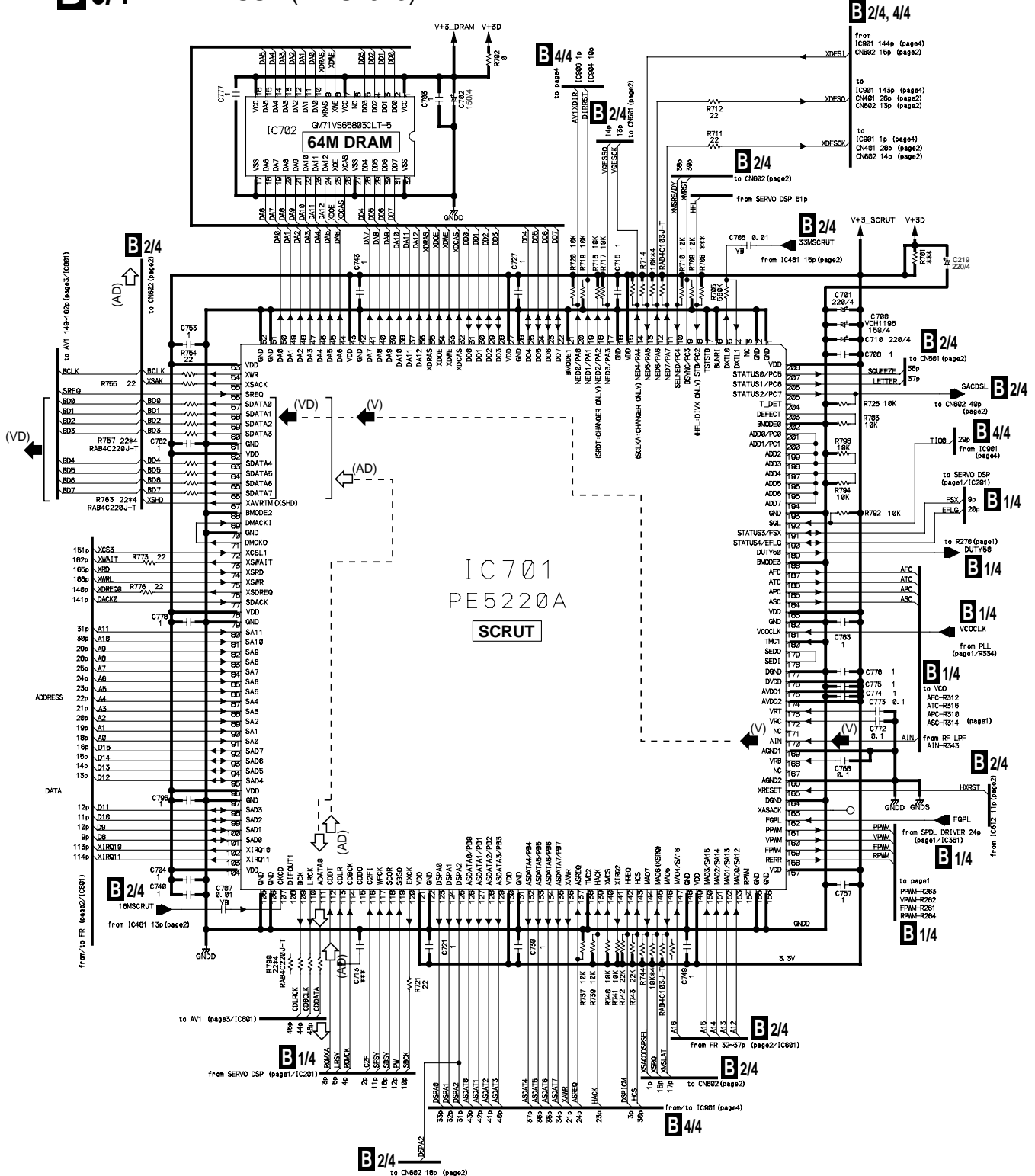

## B 3/4

- (V) : RF (VIDEO) SIGNAL ROUTE
- (VD) : VIDEO DATA SIGNAL ROUTE
- (AD) : AUDIO DATA SIGNAL ROUTE
- : AUDIO SIGNAL ROUTE
- (D) : AUDIO (DIGITAL) SIGNAL ROUTE

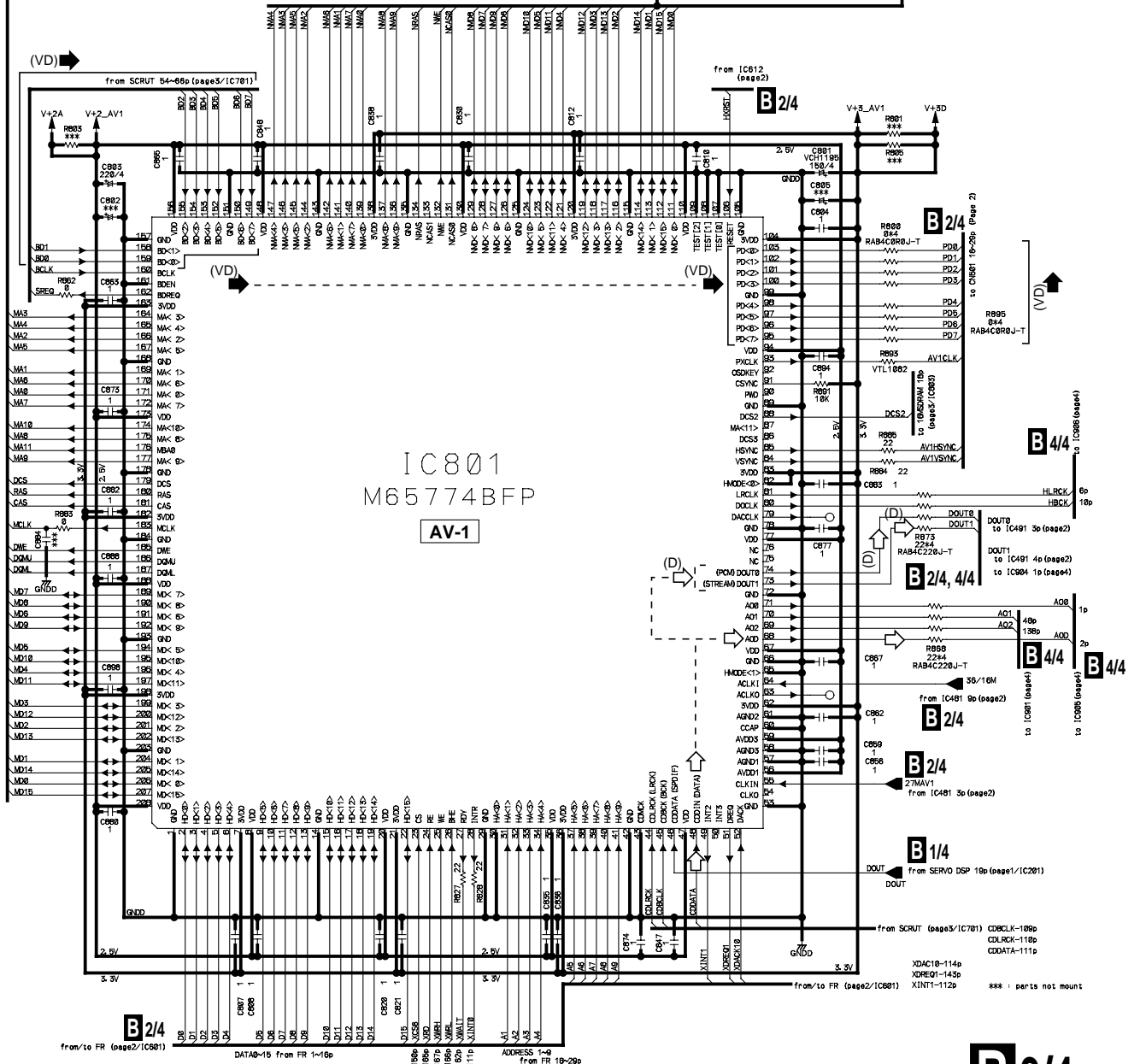
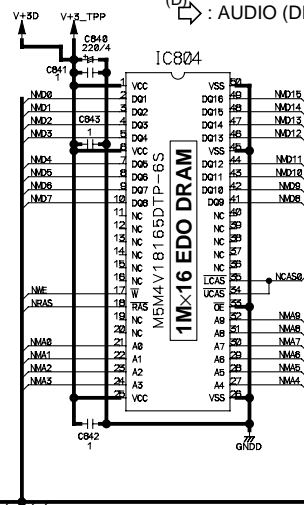
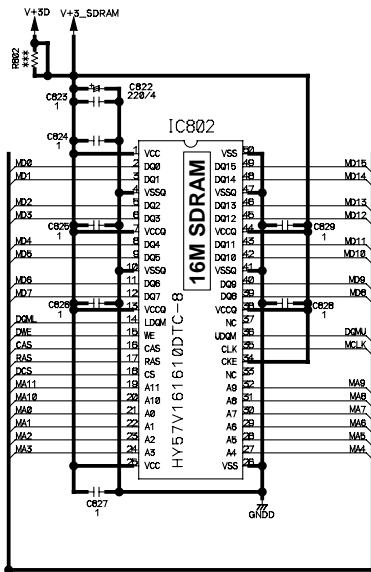

**B 3/4**

# WAVEFORMS

Note : The encircled numbers denote measuring point in the schematic diagram.

## B DVDM ASSY



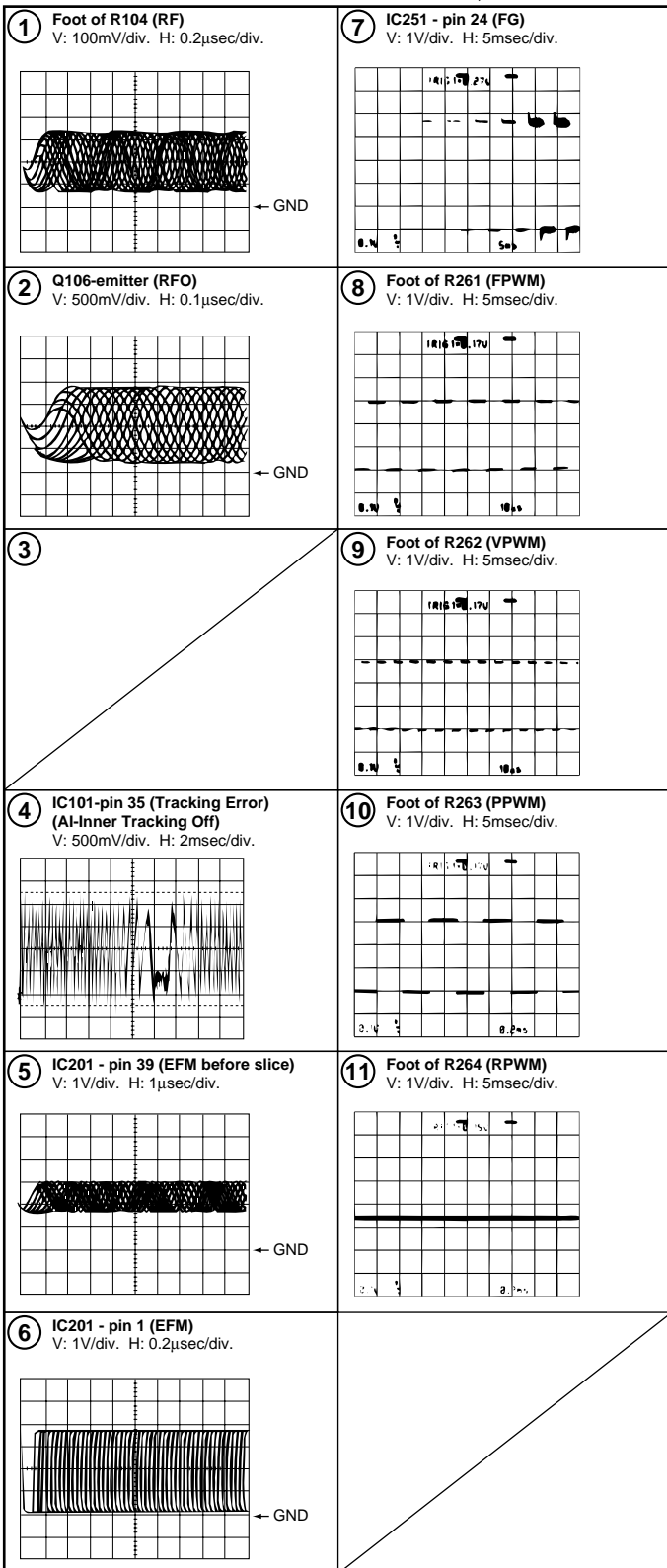





Measurement condition : No. 1 to 4 and 6 to 11 : MJK1, Title 1-chp 1  
 No. 5 : CD, ABEX-784 Track 1

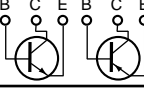

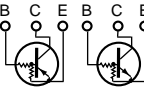
### 3.2 PCB CONNECTION DIAGRAM

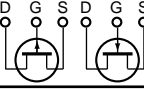
#### NOTE FOR PCB DIAGRAMS :

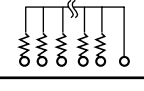
1. Part numbers in PCB diagrams match those in the schematic diagrams.
2. A comparison between the main parts of PCB and schematic diagrams is shown below.

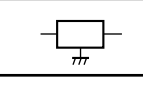
Symbol In PCB Diagrams	Symbol In Schematic Diagrams	Part Name
		Transistor
		Transistor with resistor
		Field effect transistor
		Resistor array
		3-terminal regulator

3. The parts mounted on this PCB include all necessary parts for several destinations.  
For further information for respective destinations, be sure to check with the schematic diagram.
4. View point of PCB diagrams.

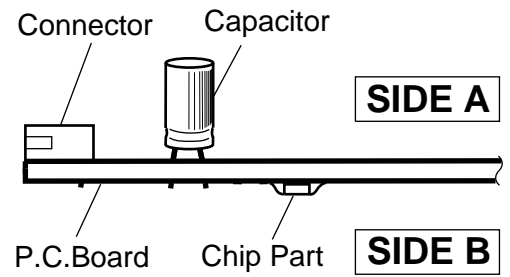

# DVDM ASSY

## B DVDM ASSY

## SIDE A

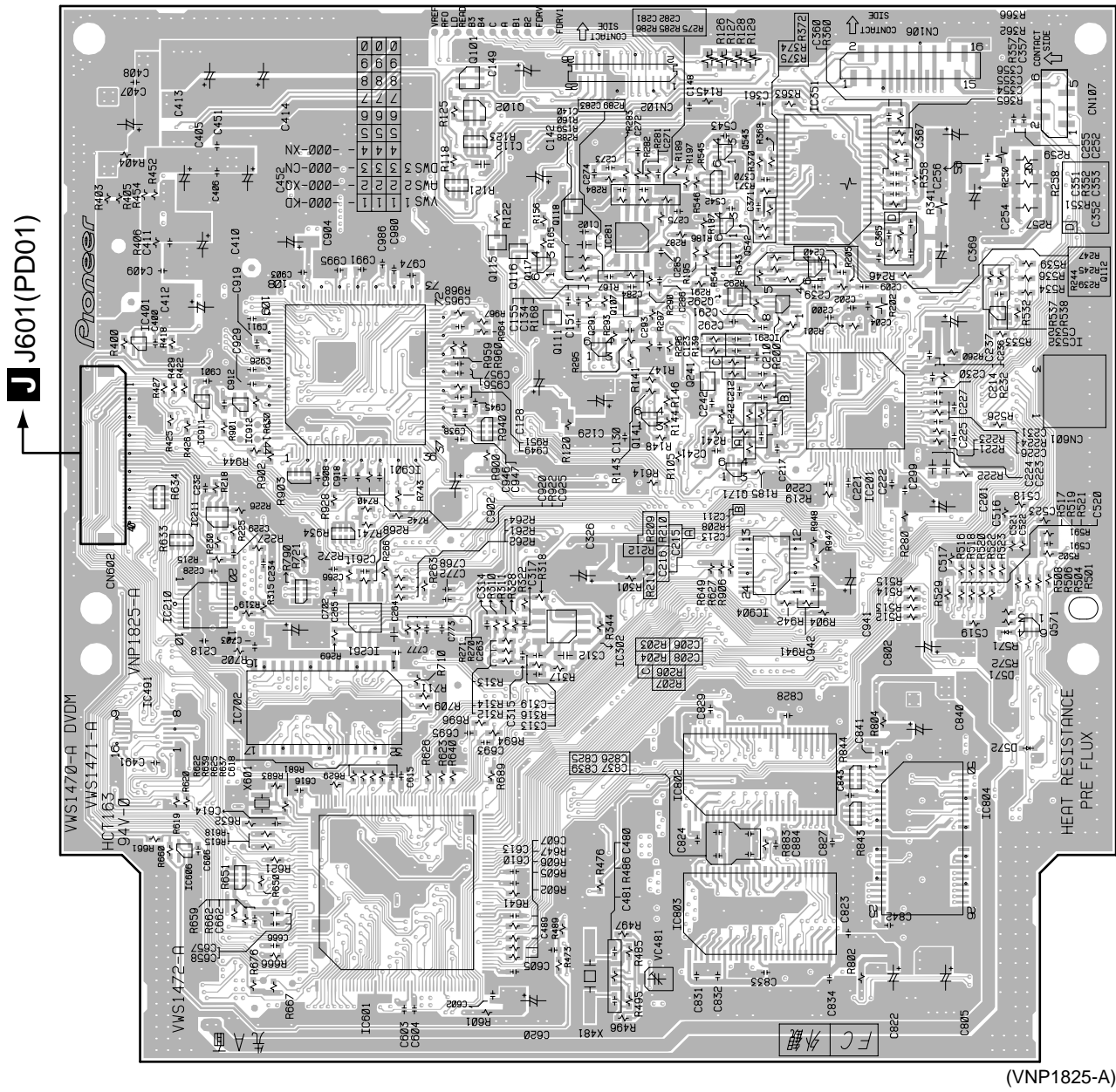

(VNP1825-A)

IC401	IC911	IC912	IC901	Q101	Q118	IC281	Q543	IC351	IC532
	IC211		IC261	Q102	Q116	Q107	Q542	Q112	Q571
IC491	IC210	IC702	IC601	Q115	Q117	Q291	Q292	IC291	IC201
IC606				IC302	Q141	Q241	IC802		IC804
							IC803		

## B

**SIDE B**

**B** DVDM ASSY

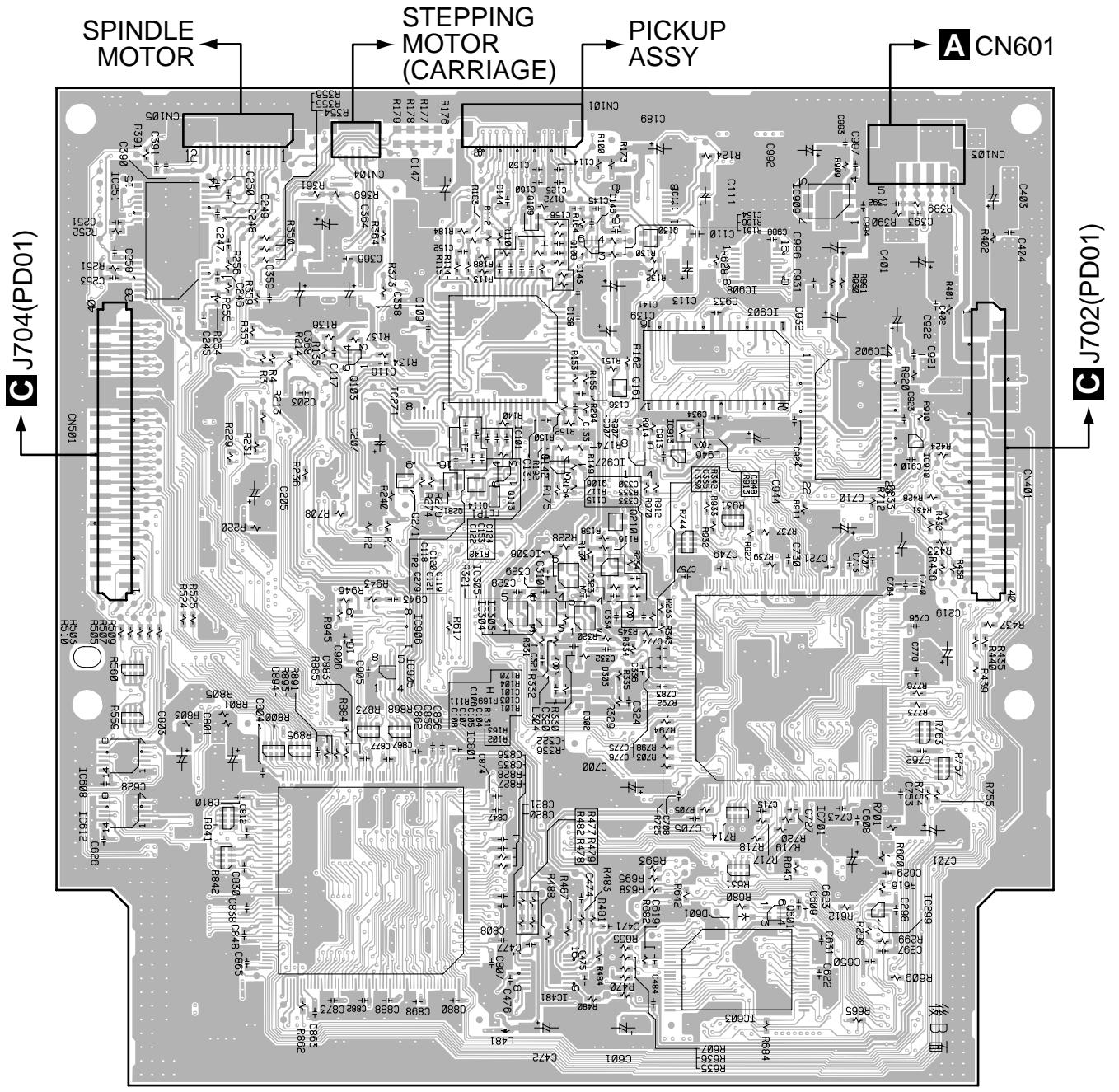

(VNP1825-A)

- |       |       |       |           |       |       |       |       |       |       |
|-------|-------|-------|-----------|-------|-------|-------|-------|-------|-------|
| IC608 | IC251 | Q103  | IC271     | Q109  | Q108  | Q130  | IC903 | IC909 | IC910 |
| IC612 |       | IC905 | Q271 Q281 | IC101 | Q142  | Q161  | IC913 | IC701 | IC902 |
|       |       | IC801 | Q113      | IC306 | Q210  |       | IC603 | Q601  | IC299 |
|       |       |       |           | IC304 | IC303 | IC305 |       |       |       |

**B**



### 3.3 GENERAL INFORMATION

When you repair the DVDM PCB, please be sure to write down the ID number.

You may need to input the ID number depending on how the PCB is repaired.

#### ID NUMBER AND ID DATA SETTING

##### ■ Entering the ID Number and ID Data for Players with DVD-Audio Compatibility

It is necessary with a player with DVD-audio compatibility to set an individual number (ID number) and ID data. If the number and data are not set correctly with the following procedure, operations in the future may not be guaranteed.

**Important:** Write down the specified ID number by checking it according to "How to confirm the ID number" shown below.

##### ■ The Input is Necessary When:

- Downloading FLASH-ROM is finished. (The latest version must be downloaded when a repair is made.)
- "No ID Number" is displayed on the screen (TV monitor) or FL display immediately after the power is turned on or in Stop mode.
- If "No ID DATA" is displayed, the ID data must be entered.

##### Note:

Be sure to enter the ID number in Stop mode.

Use the remote controller RC8300DV(DV8300) for operations. Only opening/closing of the tray are performed from the player.

##### ■ How to Input the ID Number and ID Data (FLASH-ROM)

To enter the input mode, do the following procedure when no ID number is set like just after downloading.

If an ID number has been written to the set, the ID number is memorized in the EEPROM on the front PCB board(PF01) and no number but the ID number can be input. To write another ID number to the set that an ID number is has already been written, delete the ID number in both EEPROM and Flash ROM, and input a new ID number.

- ① To enter the input mode, operate \*A1 in a status with no ID number set, such as after FLASH-ROM downloading.

Operate \*A1(ID number confirmation mode):

1. PAUSE and STOP are pushed simultaneously.
2. 1.2. and 1 are input
3. PLAY is pushed

- ② As number input is enabled when the unit enters the input mode, input the 9-digit ID number.  
(The entered number is also displayed on the FL display.)

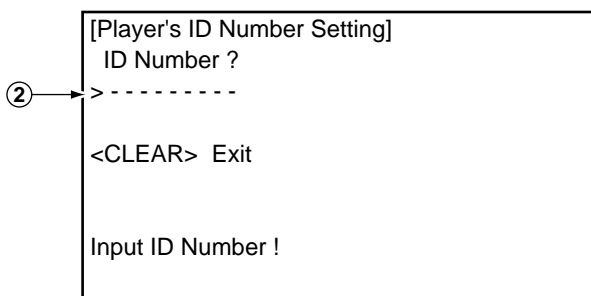

- ③ After inputting the number, press **SEARCH** to register the ID number.

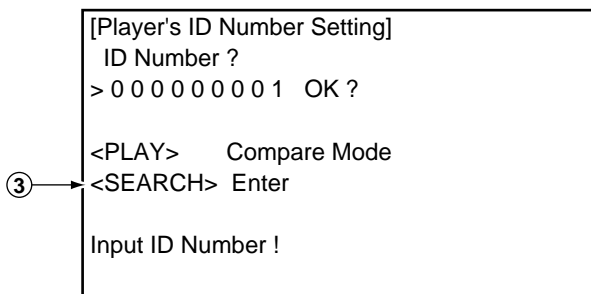

- ④ When the ID number has been registered, the unit enters the ID data input mode. (The FL display indicates "NO ID DATA.") In this condition, place the ID data disc on the tray and close the tray using the OPEN/CLOSE key on the player.

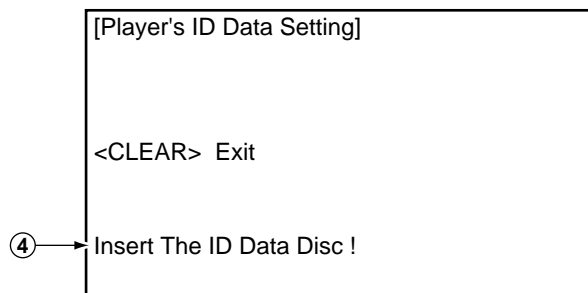

- ⑤ While the data are being read, the message shown in the figure at left is displayed on the screen. (The FL display indicates "RD ID DATA.")

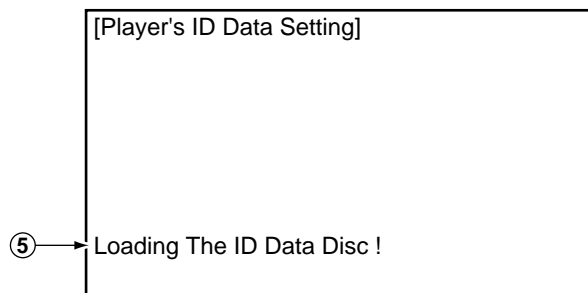

- ⑥ When the ID data have been read, the data are written to the FLASH-ROM.  
(The FL display indicates "WR ID DATA.")

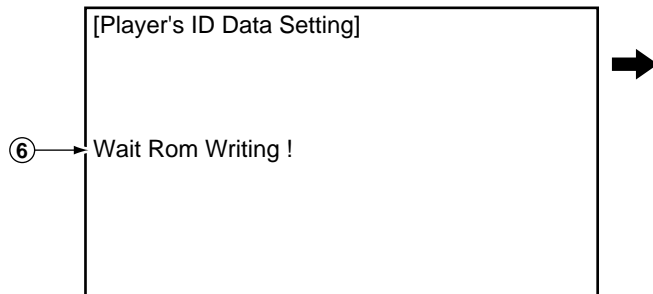

- ⑦ When the ID data have been written to the FLASH-ROM, the message "Rom Write OK" is displayed on the screen.  
(The FL display indicates "ID DATA OK.")

- ⑧ After confirming this message, press **CLEAR** to exit the input mode.

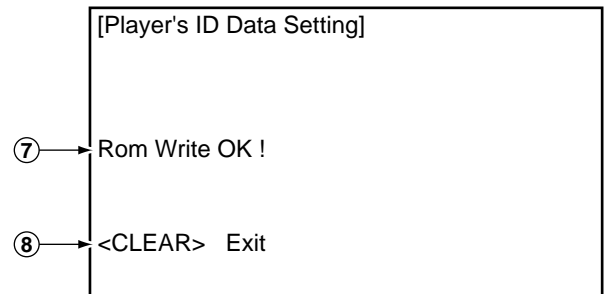

## How to Confirm the ID Number (FLASH-ROM)

- ① Operate \*A1 with an ID number set, and the unit enters the ID number confirmation mode.
- ② The set ID number is displayed on the screen (and on the FL display), permitting you to confirm it.
- ③ To exit this mode, press **CLEAR**.

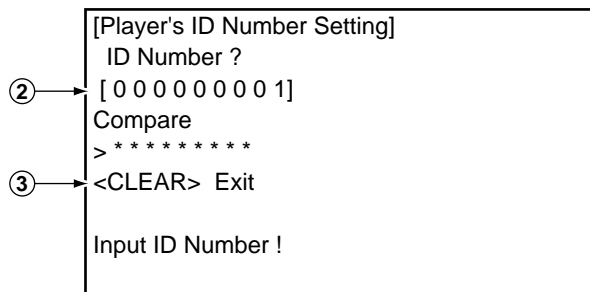

## How to Clear the ID Number (FLASH-ROM)

- ① Operate \*A1 with an ID number set, and the unit enters the ID number confirmation mode.
- ② Input the same number as the ID number you have set.

- ③ After inputting the number, press **STOP**.  
Only when the entered number matches the set ID number, the ID number is cleared and the unit exits this mode.  
If the numbers do not match, you must return to step 2.  
(**STOP** is not accepted until 9 digits are entered.)

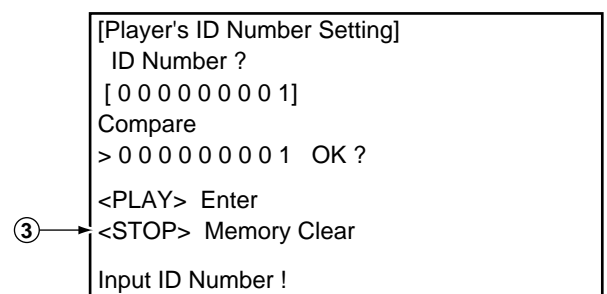
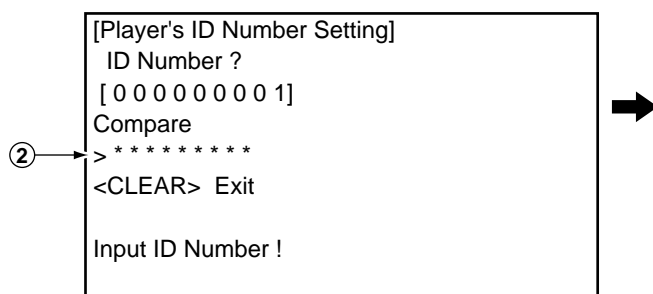

### How to confirm the ID Number. (EEP ROM)

1. Press **PLAY** + **PAUSE** of player, and the unit enter the ID number confirmation mode.
2. The set ID number is on the FL display. (9 digit numbers)
3. If the ID number of 9 digit is not inputted, it is displayed as "\_\_\_\_\_".

### How to clear the ID number. (EEP ROM)

1. Press **PLAY** + **PAUSE** of player, and the unit enter the ID number confirmation mode.
2. The set ID number is on the FL display. (9 digit numbers)
3. The following operation is carried out while the ID number is displayed.
  - a Press **PAUSE** + **STOP** of remote control.
  - b Input 1, 2 and 1 by remote control.
  - c Press **CLEAR** key of remote control.
4. Since it is displayed on FL display as "ERASE SURE", if **CLEAR** is pushed once again, ID number memorized by EEP ROM will be eliminated.

### EEP ROM の ID ナンバー確認方法

DVD プレーヤー本体の **PLAY**, **PAUSE** キーを同時に押す。

FL 管上に 9 桁の ID ナンバーが表示される。

EEP ROM に何も記憶されてない場合は、アンダーバー " \_\_\_\_\_ " が表示されます。

### EEP ROM の ID ナンバー消去方法

1. DVD プレーヤー本体の **PLAY**, **PAUSE** キーを同時に押す。FL 管上に 9 桁の ID ナンバーが表示される。
2. 9 桁の ID ナンバーが表示されている間にリモコンで "**PAUSE**, **STOP** 同時押し、**1, 2, 1** 入力、そして **CLEAR** を押す" と FL 管上に "**ERASE SURE**" と表示されるので、もう一度 **CLEAR** を押すと EEP ROM に記憶された ID ナンバーが消去されます。

注意：

この基板（DVDM）を修理するときは必ず ID ナンバーを書き留めておいて下さい。  
基板（DVDM）の修理方法によって ID ナンバーの入力が必要になります。

## IDナンバー及びIDデータ設定

### ■ DVDオーディオ対応プレーヤーのIDナンバー及びIDデータ入力について

DVDオーディオ対応プレーヤーではDVDオーディオディスク再生のために、各プレーヤー毎に個別の番号(IDナンバー)とIDデータを設定する必要があります。この番号とデータを、以下の手順で正しく設定しないと、将来にわたる動作保証ができなくなります。

重要: FLASH ROMのダウンロード前に、右頁の” IDナンバーの確認方法” に従い設定されているIDナンバーを書き留めておいてください。

### ■ 入力が必要な場合

- FLASH ROMのダウンロード後。
- 電源投入直後または停止中に、画面上またはFL管に” No ID Number” と表示される場合。
- ” No ID DATA” と表示される時は、IDデータの入力が必要です。

注)

IDナンバー入力は停止中に行ってください。

操作は全てリモコン（RC8300DV）で行います。但し、トレイの開閉は本体キーで行います。

### ■ IDナンバー及びIDデータの入力方法

- ① 入力モードに入るには、ダウンロード後などのIDナンバーが何も設定されていない状態で 手順\*A1を行う。  
手順\*A1（IDナンバー確認モードに入る）
  1. PAUSE and STOP 同時に押す
  2. 121と数字を入力
  3. PLAYを押す
- ② 入力モードに入ると数字が入力できる状態になるので、9桁のIDナンバーを入力します。（FL管に表示されます。）
- ④ IDナンバーが設定されると、IDデータ入力状態になります。（FL管には” IN ID DATA” と表示されます。）この状態でIDデータディスクをDISCトレイに載せ本体クローズキーでクローズするとデータを読み込みます。

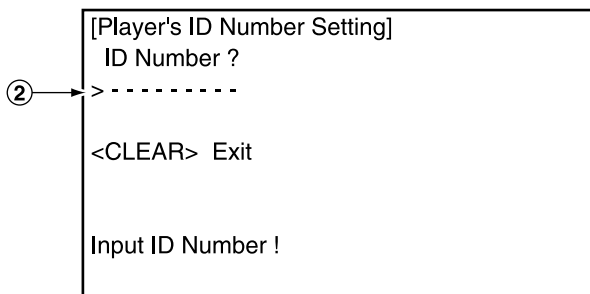

- ③ 数字入力後 [SEARCH]を入力すると、IDナンバーが設定できます。

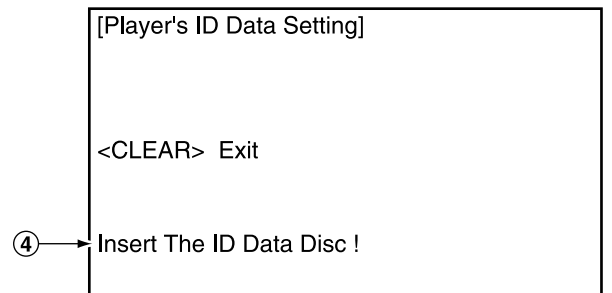
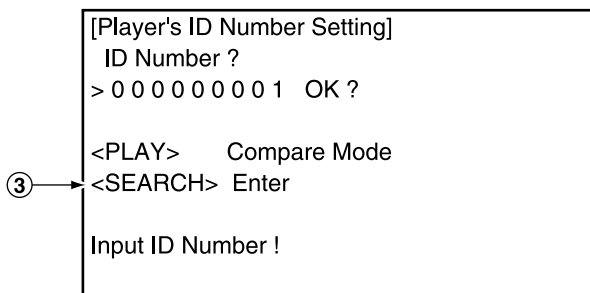

- ⑤ データ読み込み中は画面上に下記のような表示がされます。（FL管には” RD ID DATA” と表示されます。）

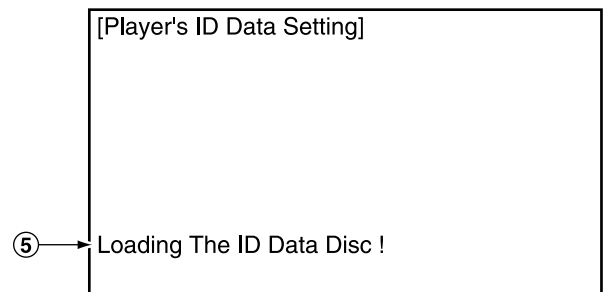

⑥ IDデータを読み込むとデータをFLASH ROMに書き込みます。  
(FL管には” WR ID DATA” と表示されます。)

⑦ FLASH ROMへの書き込みが終了すると画面上に  
” Rom Write OK!” と表示されます。  
(FL管には” ID DATA OK” と表示されます。)

⑧ この表示を確認したら[CLEAR]を入力し、設定モードを終了  
します。

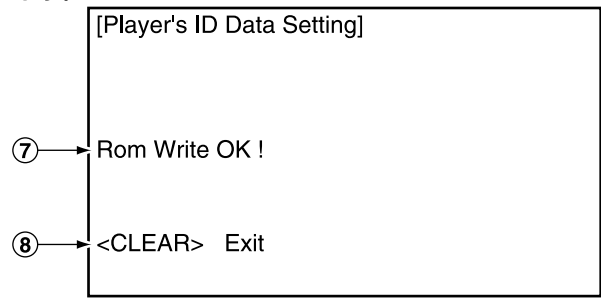
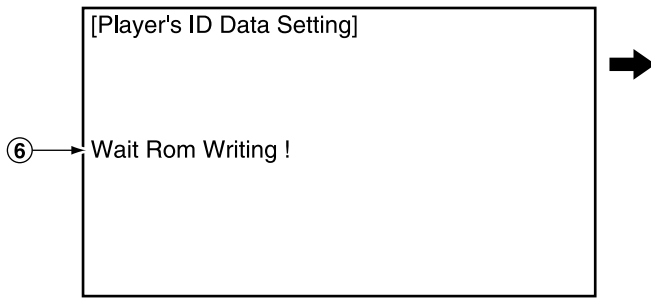

### ■ IDナンバーの確認方法

① IDナンバーが設定されている状態で 手順\*A1を行うと  
IDナンバー確認モードに入ります。

② 設定されているIDナンバーが表示されるので、ここで確認する  
ことができます。(FL管にも表示されます。)

③ [CLEAR]を入力するとこのモードから抜けることができます。

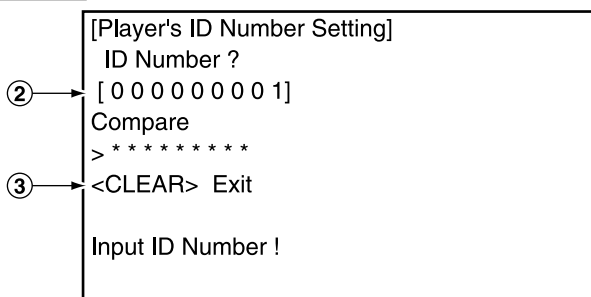

### ■ IDナンバー消去方法

① IDナンバーが設定されている状態で手順\*A1を行うと  
IDナンバー確認モードに入ります。

② 設定されているIDナンバーと同じ数字を入力します。

③ 数字入力後、[STOP]を入力してください。  
入力した数字と設定されているIDナンバーが一致した場合  
だけIDナンバーを消去し、このモードを抜けます。  
数字が一致しない場合は、②へ戻ります。  
(9桁入力するまでは[STOP]を受け付けません。)

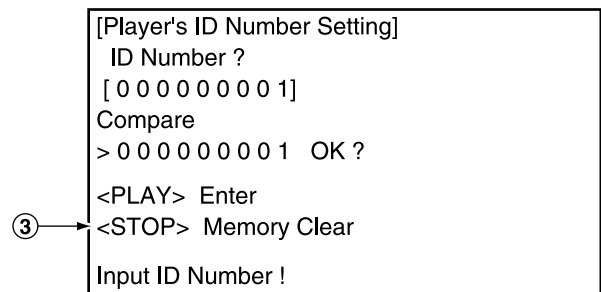
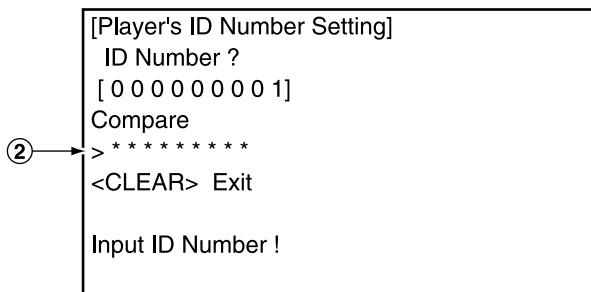

E2P ROM の ID ナンバー確認方法 および E2P ROM の ID ナンバーの消去方法は 3-20 ページ参照

## Disassembly of the Traverse Mechanism Assy and the Pickup Assy

- ① Remove the Bonnet and Tray Panel.
- ② Remove the Front Panel.
- ③ Remove the Loading Mechanism Assy (Screws ×4).
- ④ Remove the Bridge (Screw ×2).
- ⑤ Pull out the Tray and remove it while unhooking a Hook.
- ⑥ Turn the Short SW to Short side.

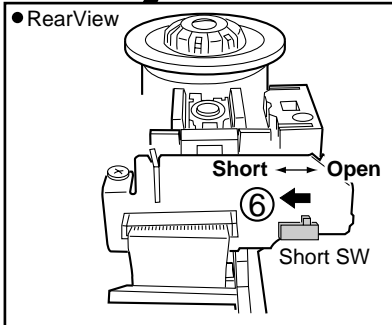
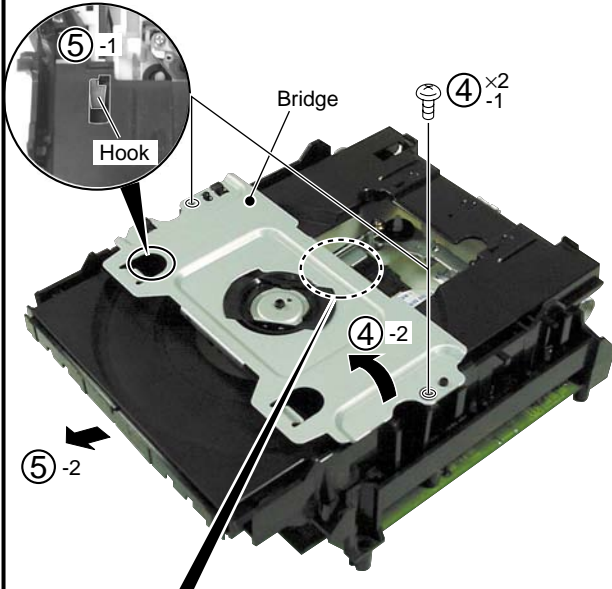

### Caution in the tray insertion

In the Tray insertion, insert it after matching a triangle mark of the Loading Base and a position of pin of the Drive Cam.

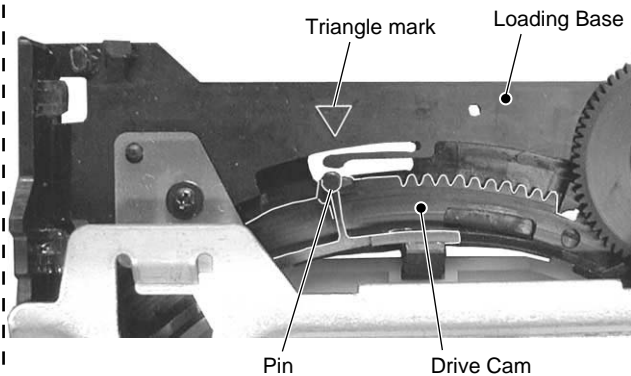

- ⑦ Remove the DVDM Assy (Screws ×2).
- ⑧ Remove four screws.
- ⑨ Remove the Mechanism Holder.

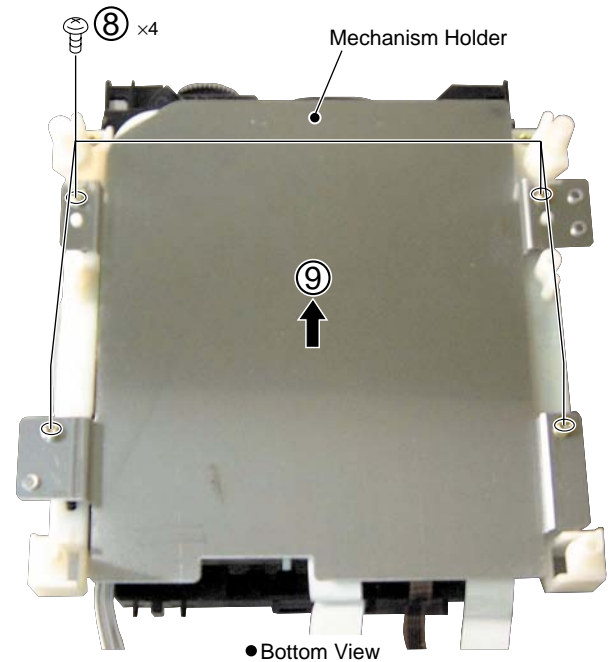

- ⑩ Remove a screw.

### Cautions:

Screw is locked with Silicone adhesive.  
Please lock it with Silicone adhesive when installs it.

- ⑪ Remove the FFC Holder with the state which Flexible Cable was attached.

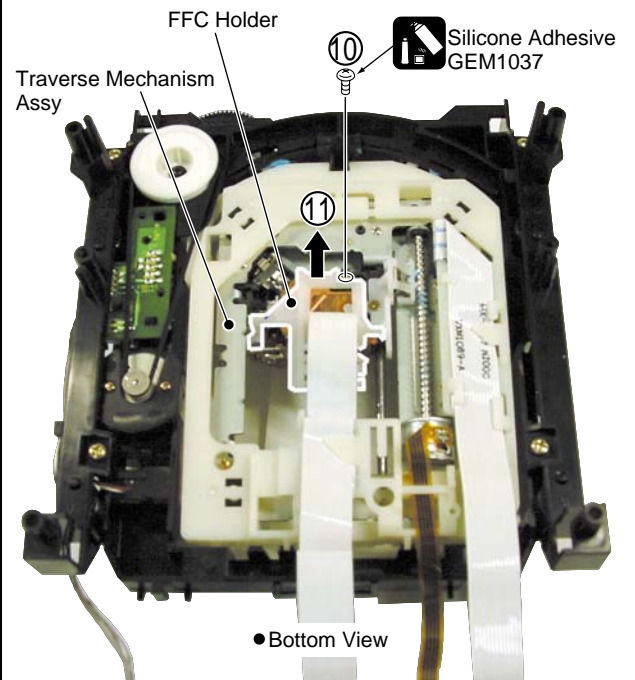



● When Removing The Traverse Mechanism Assy

- ⑫ Remove the Pickup Flexible Cable
- ⑬ Unhook ( ×4)
- ⑭ Remove the Traverse Mechanism Assy

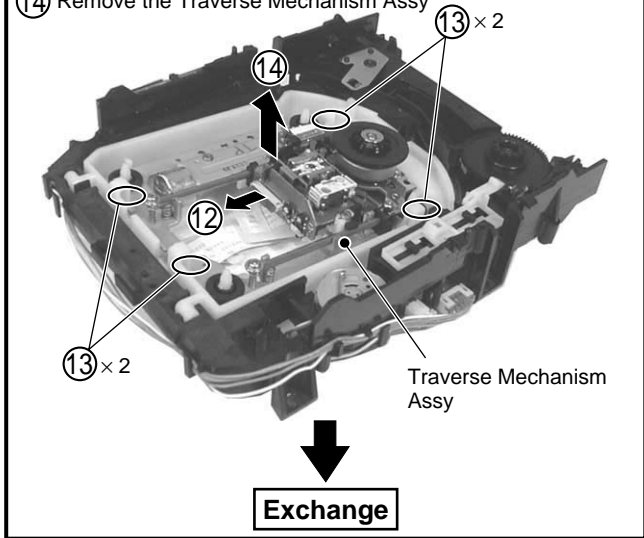

● When Removing The Pickup Assy

- ⑫ Remove the Pickup Flexible Cable.

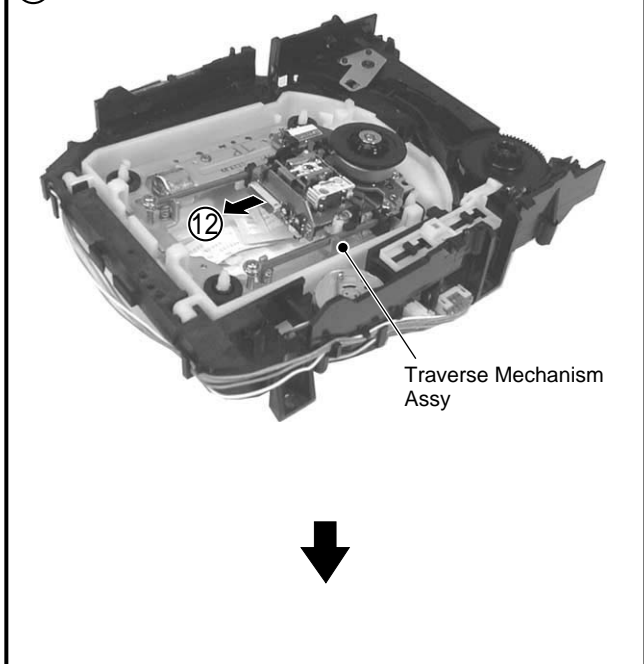

- ⑬ Remove two Skew Screws and two Skew Springs.
- ⑭ Remove the Pickup Assy.

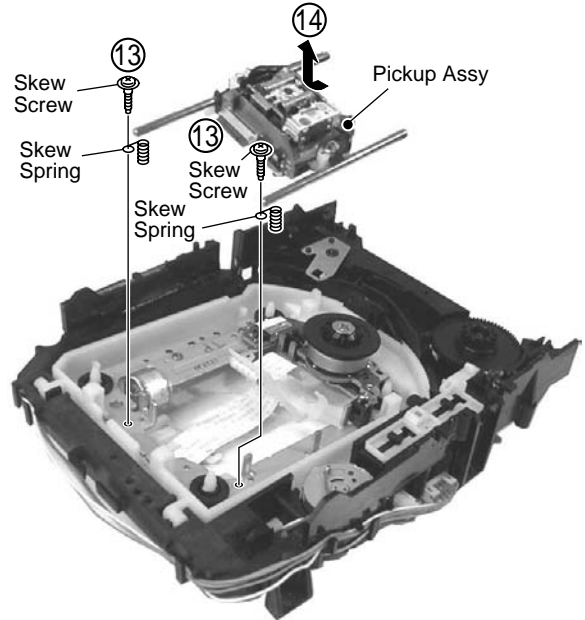

- ⑮ Remove two screws.

**Cautions:**  
Screw is locked with Silicone adhesive.  
Please lock it with Silicone adhesive when installs it.

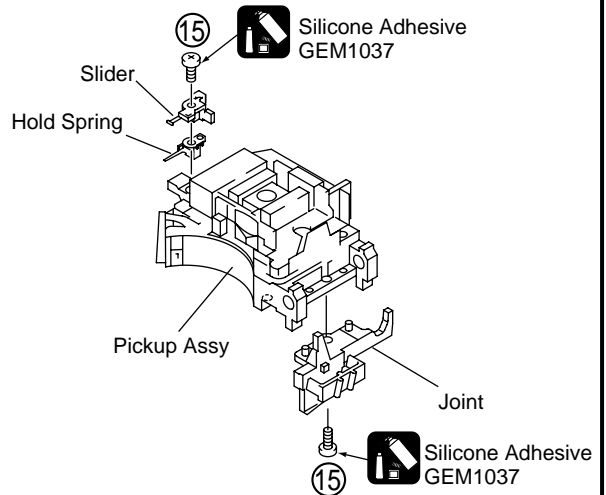

**Exchange**

**Styling the Pickup Flexible Cable**

- ① Fold a edge of lining part of the Pickup Flexible Cable.
- ② Insert the Pickup Flexible Cable in connector, and lock it surely.

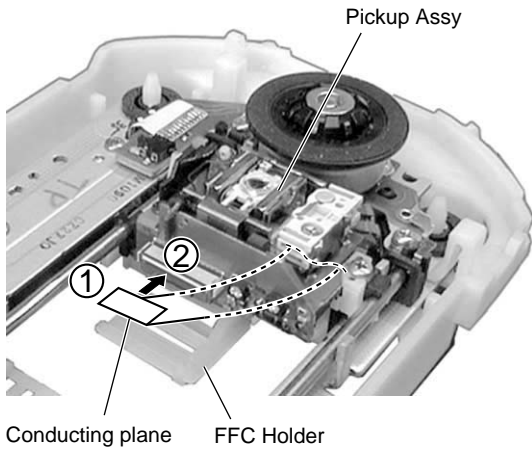

**Caution:**  
Move the Pickup to the innermost of the disc.

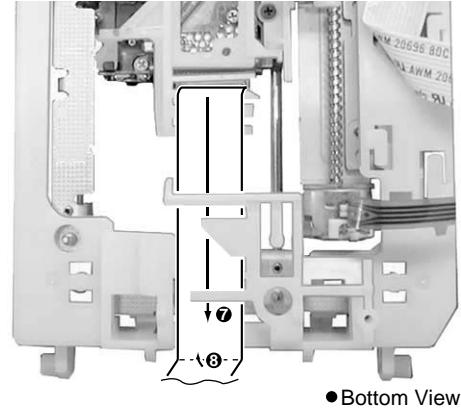

- ③ Perform the styling as shown in figure below.

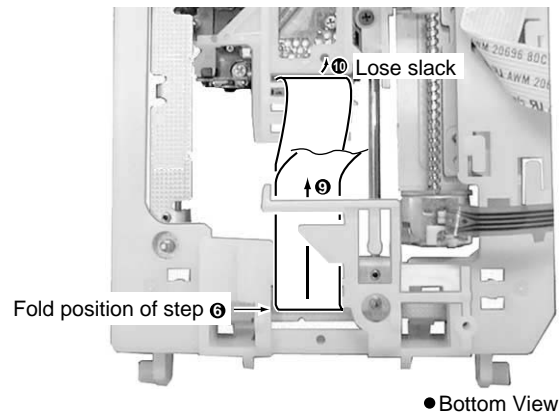
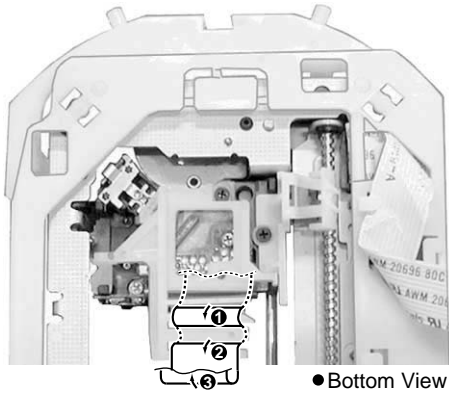

Fold it at the position of reference line.

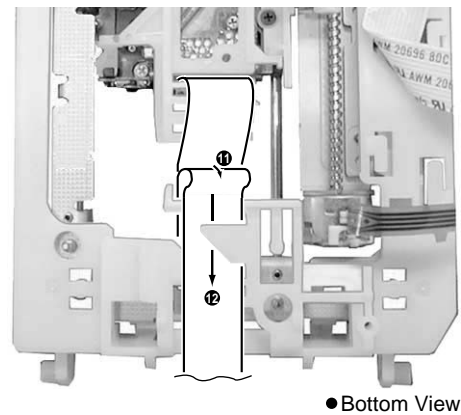
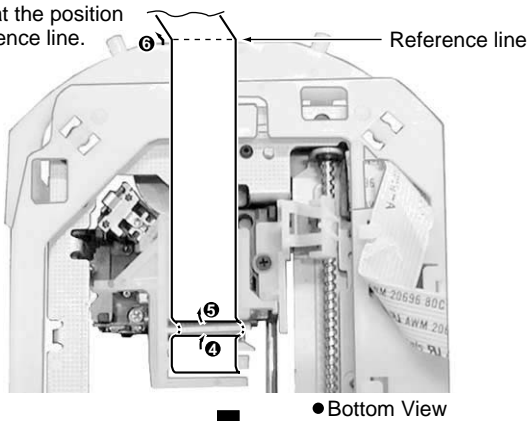



IC DATA

■ LA9701M (DVDM ASSY : IC101)

- RF IC
- Block Diagram

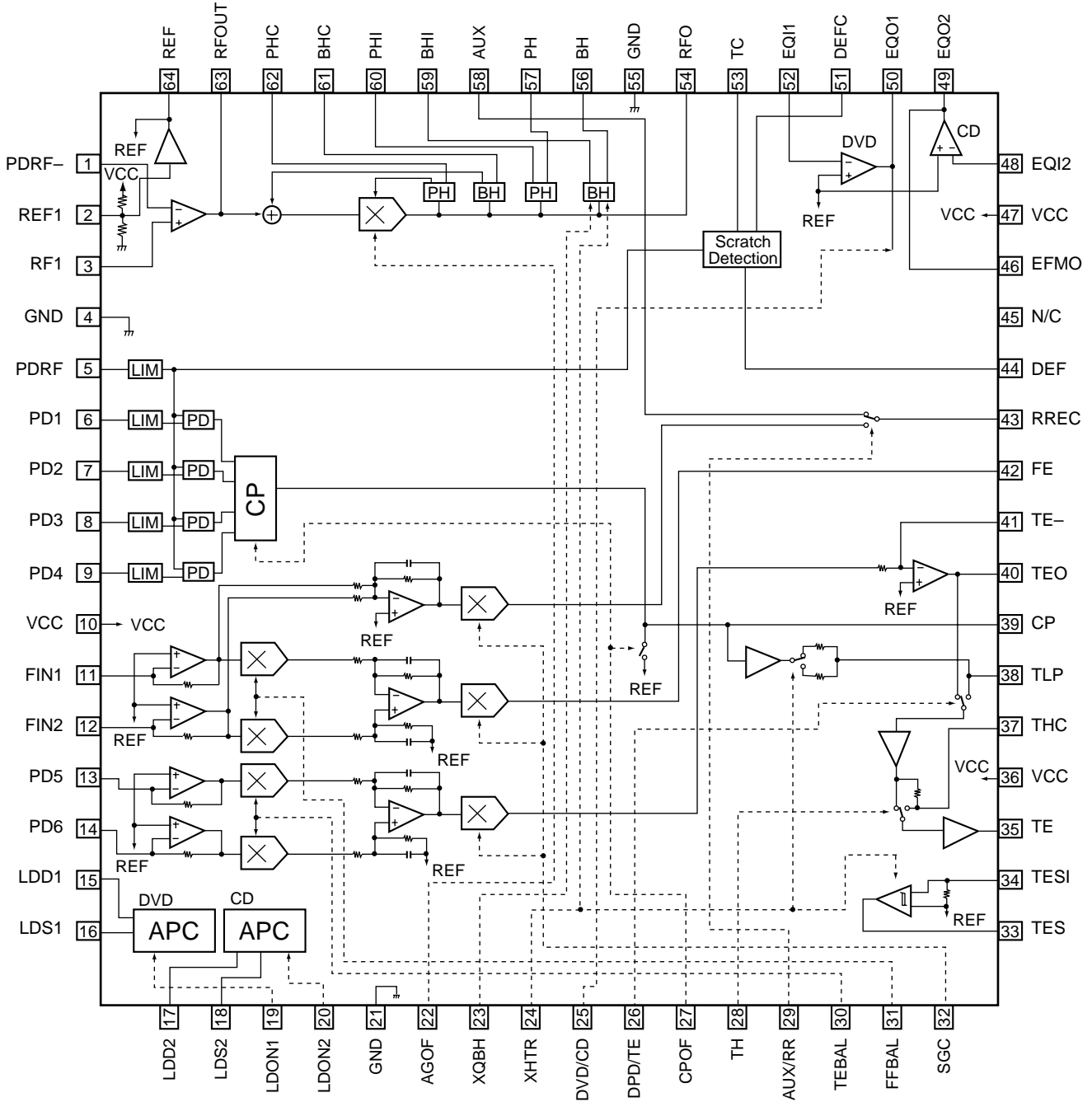

**LC78652W (DVDM ASSY : IC201)**

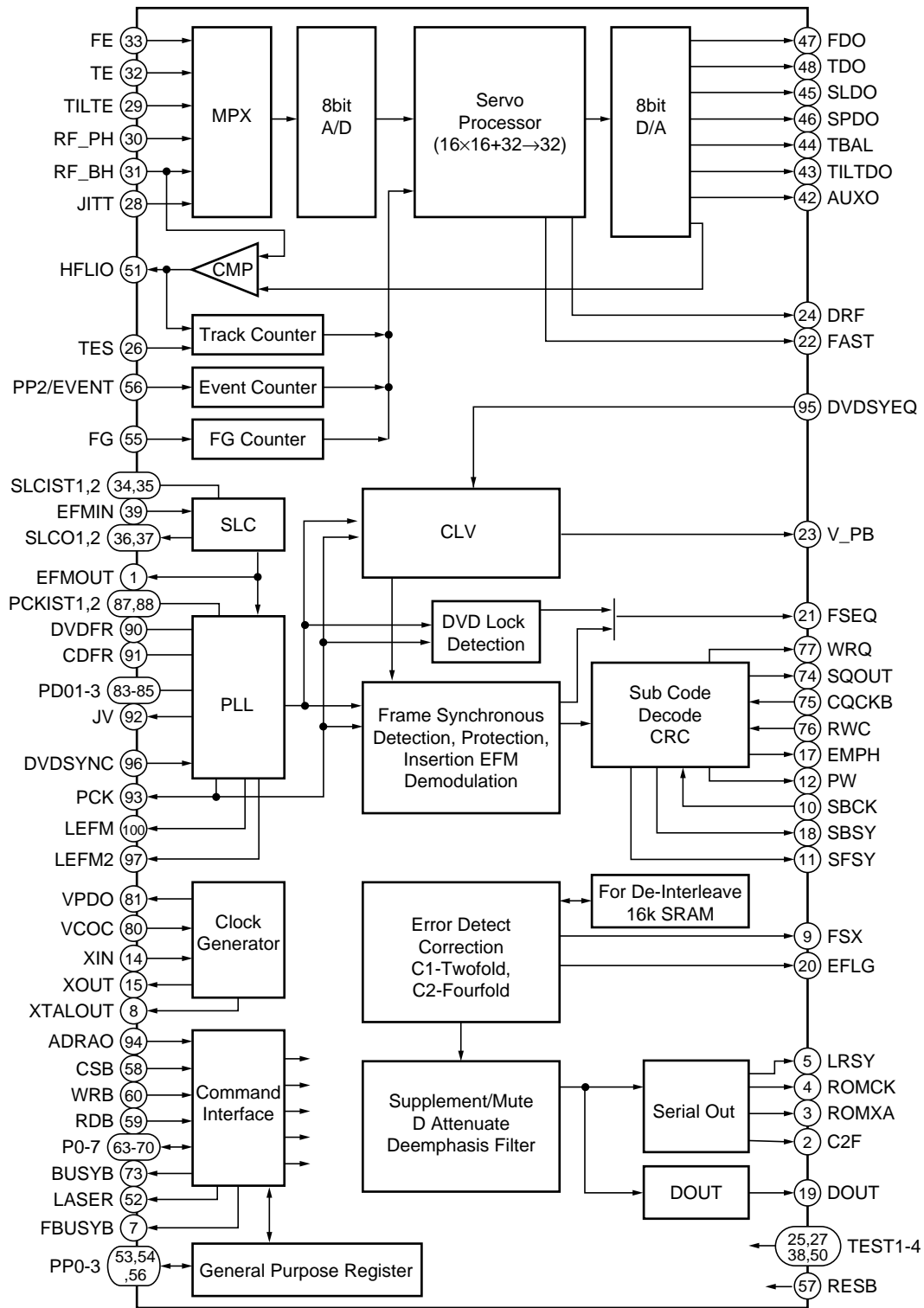

## LC78652W (DVDM ASSY : IC201)

No.	Pin Name	I/O	Function
1	EFMOUT	O	Output the state that was binary-stated value EFM
2	C2F	O	C2 flag output
3	ROMXA	O	CD-ROM data output
4	ROMCK	O	Shift clock output for CD-ROM data output
5	LRSY	O	L/R clock output for CD-ROM data output
6	PP3	I/O	General-purpose port input/output / DVD sync. signal input      N ch-OD output
7	FBUSYB	O	Busy signal output of DSP process operation      N ch-OD output
8	XTALOUT	O	External system clock output
9	FSX	O	CD 1 frame sync. signal output
10	SBCK	I	Subcode reading out clock input
11	SFSY	O	Frame sync. signal output of subcode
12	PW	O	Subcode P, Q, R, S, T, U, V and W output
13	VSS	-	GND pin
14	XIN	I	Connect a crystal resonator (16.9344MHz)
15	XOUT	O	Connect a crystal resonator
16	DVDD1	-	3.3V power supply of the oscillation circuit
17	EMPH	O	Monitor pin of the deemphasis
18	SBSY	O	Sync. signal output of the subcode block
19	DOUT	O	Audio EIAJ data output
20	EFLG	O	Error correction state monitor of the error correction C1 and C2
21	FSEQ	O	Detection monitor of the CD/DVD frame sync. signal
22	FAST	O	Playback speed monitor      N ch-OD output
23	V_PB	O	Monitor output of the rough servo/CLV control
24	DRF	O	In focus monitor
25	TEST3	I	Test input 3
26	TES	I	Tracking error signal input
27	TEST2	I	Test input 2
28	JITT	I	Jitter quantity detecting signal input of EFM PLL
29	TILTE	I	Tilt error signal input
30	RF_PH	I	RF peak hold signal input
31	RF_BH	I	RF bottom hold signal input
32	TE	I	Tracking error signal input
33	FE	I	Focus error signal input
34	SLCIST1	-	Current setting pin 1 of the constant current charge pump for SLC
35	SLCIST2	-	Current setting pin 2 of the constant current charge pump for SLC
36	SLCO1	O	Control output 1 for SLC
37	SLCO2	O	Control output 2 for SLC
38	TEST1	I	Test input 1
39	EFMIN	I	EFM/EFM + input
40	AVDD	-	5V power supply of A/D and D/A for servo
41	AVSS	-	GND of A/D and D/A for servo
42	AUXO	O	DA auxiliary output
43	TILTDO	O	Tilt control signal output
44	TBAL	O	Tracking balance control signal output
45	SLDO	O	Sled control signal output
46	SPDO	O	Spindle control signal output
47	FDO	O	Focus control signal output
48	TDO	O	Tracking control signal output
49	VREF	-	Reference level of D/A for servo
50	TEST4	I	Test input 4

## LC78652W (DVDM ASSY : IC201)

No.	Pin Name	I/O	Pin Function
51	HFLIO	I/O	Mirror detection signal input/output
52	LASER	O	Output pin for laser ON/OFF control
53	PP0/DVD_CDB	I/O	General-purpose port input/output / Disc discrimination signal output
54	PP1/CRCERRB	I/O	General-purpose port input/output / Subcode CRC result signal output
55	FG	I	FG counter input
56	PP2/EVENT	I/O	General-purpose port input/output / Event counter input
57	RESB	I	Reset input
58	CSB	I	Chip select input
59	RDB	I	Internal state reading signal input
60	WRB	I	Command / data writing signal input
61	DVDD2	-	5V power supply
62	VSS	-	GND
63	P0	I/O	Command / data input/output
64	P1		
65	P2		
66	P3		
67	P4		
68	P5		
69	P6		
70	P7		
71	VSS	-	GND
72	DVDD1	-	3.3V power supply for internal
73	BUSYB	O	Busy signal output of command process
74	SQOUT	O	Serial output of subcode Q
75	CQCKB	I	Shift clock input for subcode Q data output
76	RWC	I	Update permission input of subcode Q
77	WRQ	O	Read out ready monitor of subcode Q
78	AVSS	-	PLL GND for internal system clock
79	VRPFR	-	VCO oscillation range setting of PLL for system clock
80	VCOC	I	Connect a PLL filter for system clock
81	VPDO	O	
82	AVDD	-	PLL 5V power supply for system clock
83	PDO1	I/O	PLL filter connection pin 1 for EFM playback
84	PDO2	I/O	PLL filter connection pin 2 for EFM playback
85	PDO3	I/O	PLL filter connection pin 3 for EFM playback
86	AVSS	-	PLL GND for EFM playback
87	PCKIST1	-	Current setting 1 of PLL constant current charge pump for EFM playback
88	PCKIST2	-	Current setting 2 of PLL constant current charge pump for EFM playback
89	AVDD	-	PLL 5V power supply for EFM playback
90	DVDFR	-	VCO oscillation range setting of PLL for EFM playback 1
91	CDFR	-	VCO oscillation range setting of PLL for EFM playback 2
92	JV	O	Jitter output of PLL clock for EFM playback
93	PCK	O	Bit clock output for EFM playback
94	ADRAO	I	Address input
95	DVDSYEQ	I	DVD synchronize pulse input
96	DVDSYNC	I	DVD synchronous signal input
97	LEFM2	O	Output the state that cut and out a signal which was binary-stated value EFM with PCK 2
98	DVDD1	-	3.3V power supply for I/O
99	VSS	-	GND
100	LEFM	O	Output the state that cut and out a signal which was binary-stated value EFM with PCK 1

## ■ BA6664FM (DVDM ASSY : IC251)

• Three-phase Motor Driver

### ● Block Diagram

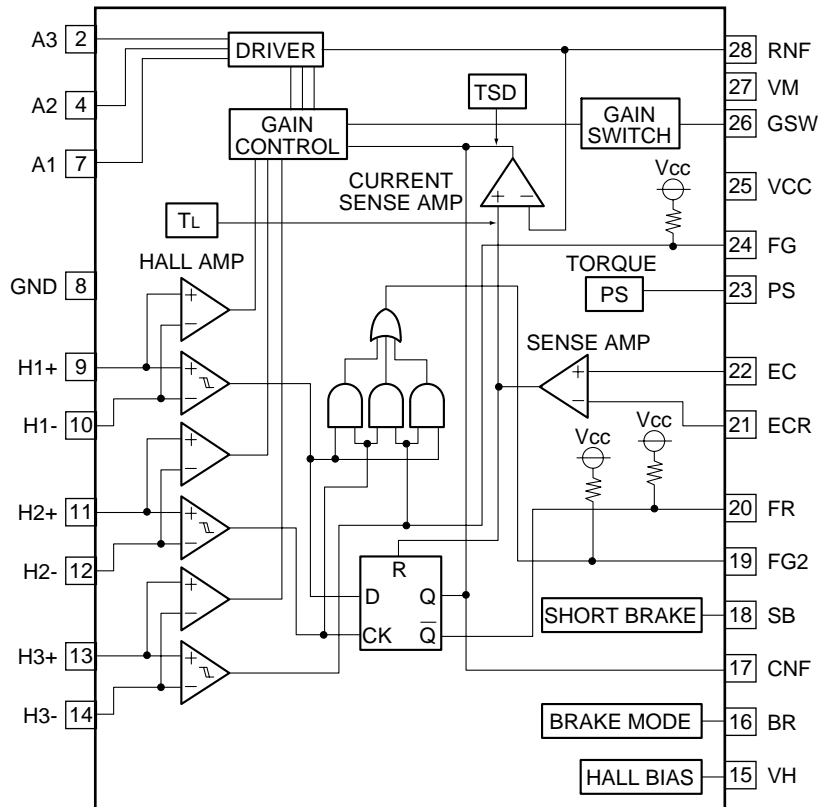

### ● Block Diagram

No.	Pin Name	Pin Function	No.	Pin Name	Pin Function
1	N.C.	N.C.	16	BR	Brake mode switching pin
2	A3	Output pin	17	CNF	Capacitor connection pin for phase compensation
3	N.C.	N.C.	18	SB	Short brake pin
4	A2	Output pin	19	FG2	FG 3-phase mix signal output pin
5	N.C.	N.C.	20	FR	Rotation detecting pin
6	N.C.	N.C.	21	ECR	Control reference pin of output voltage
7	A1	Output pin	22	EC	Output voltage control pin
8	GND	GND pin	23	PS	Power save pin
9	H1+	Hall signal input pins	24	FG	FG signal output pin
10	H1-		25	VCC	Power supply pin
11	H2+		26	GSW	Gain switching pin
12	H2-		27	VM	Motor power pin
13	H3+		28	RNF	Resistor connection pin for output current detection
14	H3-		FIN	FIN	GND
15	VH	Hall bias pin			

## ■ PD6345A (DVDM ASSY : IC601)

• FR CPU

### ● Pin Function

No.	Mark	Pin Name	I/O	Pin Function
1	P20/D16	D0	I/O	Data bus input/output
2	P21/D17	D1		
3	P22/D18	D2		
4	P23/D19	D3		
5	P24/D20	D4		
6	P25/D21	D5		
7	P26/D22	D6		
8	P27/D23	D7		
9	P30/D24	D8		
10	P31/D25	D9		
11	P32/D26	D10		
12	P33/D27	D11		
13	P34/D28	D12		
14	P35/D29	D13		
15	P36/D30	D14		
16	P37/D31	D15		
17	VSS	GND	-	Ground
18	P40/A00	A0	O	Address bus output
19	P41/A01	A1		
20	P42/A02	A2		
21	P43/A03	A3		
22	P44/A04	A4		
23	P45/A05	A5		
24	P46/A06	A6		
25	P47/A07	A7		
26	VCC3	V+3.3D	-	Power supply
27	VCC2	V+2.5D	-	Power supply
28	P50/A08	A8	O	Address bus output
29	P51/A09	A9		
30	P52/A10	A10		
31	P53/A11	A11		
32	P54/A12	A12		
33	P55/A13	A13		
34	P56/A14	A14		
35	P57/A15	A15		
36	VSS	GND	-	Ground
37	P60/A16	A16	O	Address bus output
38	P61/A17	A17		
39	P62/A18	A18		
40	P63/A19	A19		
41	P64/A20	A20		
42	P65/A21	TOFSTA	O	Tracking offset injection -A for servo
43	P66/A22	TOFSTC	O	Tracking offset injection -C for servo
44	P67/A23	WBL	O	For Wobble detection corresponding to DVD R/W (main)
45	DAVS	GND	-	Ground
46	DAVC	V+3.3D	-	Power supply
47	DA0	STEP1	I	For stepping motor control
48	DA1	STEP2	I	
49	DA2	LODRV	I	

No.	Mark	Pin Name	I/O	Pin Function
50	AN0	STEP2	I	For stepper control 2 For offset cancel of D/A output
51	AN1	STEP1	I	For stepper control 1 For offset cancel of D/A output
52	AN2	NAP SW	I	Rear panel H/M/L=M/A/P
53	AN3	XOEM	I	OEM model protection input
54	AN4	LD CUR	I	Input for LD current value indication
55	AN5	SELPOS	I	Tray selector input of microchanger
56	AN6	CLAMPSW	I	Clamp position SW input
57	AN7	LODPOS	I	Loading clamp position SW input
58	AVCC	V+3.3D	-	Power supply
59	AVRH	V+3.3D	-	Power supply
60	AVSS/AVRI	GND	-	Ground
61	VSS	GND	-	Ground
62	PP0/ATGX	SLDPOS	I	SW input of slider inside position
63	PP1/FRCK	GSW	O	Gain up at ACBR (at ACBR: H, others: L)
64	PP2/IN0	780ON	I	ON/OFF control signal of 780nm laser diode
65	PP3/IN1	SEDO	O	Tray rotation drive output
66	PP4/IN2	XMON	O	Mute of DRV (spindle motor ON: H)
67	PP5/IN3	XDRVMUT	O	FTS driver mute output
68	PP6	LT1	O	Communication response to the FL controller
69	PP7	XRDY	I	Communication request from the FL controller
70	VCC3	V+3.3D	-	Power supply
71	VCC2	V+2.5D	-	Power supply
72	PO0/OC0	XCURDET	I	Actuator current detection input Servo OFF for "L" 300ms
73	PO1/OC1	XCBUSY	I	Busy signal of command process Command acceptable : "L"
74	PO2/OC2	XDSPRST	O	Servo DSP reset
75	PO3/OC3	BCA	-	BCA read signal (at BCA read: H) (Not used)
76	PO4/OC4	DSCSNS/ XCD4X	I/O	Disc detection pulse "L": Disc exist Correspond to fourth speed CD playback ("L": Fourth speed)
77	PO5/OC5	PPCNT	O	Switch of TZC in WBL traversal (at PP: H)
78	PO6/OC6	XDFINH	O	Defect signal control (DEFECT ON: Hi-Z, OFF: "L")
79	PO7/OC7	DPD/TE	O	H=1 beam, L=3 beams
80	VSS	GND	-	Ground
81	PN0/AIN0	DVD/XCD	O	RF EQ switching signal at DVD/CD "H": DVD, "L": CD
82	PN1/BIN0	AGOFF	O	"H": Turn off AGC of RFIC
83	PN2/AIN1	650X780	O	780nm/650nm switching signal
84	PN3/BIN1	LD ON	O	ON/OFF control signal of laser diode
85	PN4/AIN2	FOFST2	O	Focus offset adjustment 1 (Tri-value control "H", "L", Hi-Z)
86	PN5/BIN2	FOFST1	O	Focus offset adjustment 2 (Tri-value control "H", "L", Hi-Z)
87	PN6/AIN3	XCD2X	O	For VCD double speed playback
88	PN7/BIN3	OEICG	O	"H": Gain of OEIC up to 6dB
89	PM0/ZIN0	TRYPOS	I	Count input of disc number
90	PM1/ZIN1	N/XP SW	O	Video encoder control port (NTSC/PAL)
91	PM2/ZIN2	V SEL	O	(Composite, S) / (YCbCr) or (RGB) switch
92	PM3/ZIN3	V SEL2	O	(Composite) of skirt terminal / (S) switch
93	PL0/SDA1	SDAI		12C control lines
94	PL1/SDA0	SDAO		
95	PL2/SCL1	SCLI		
96	PL3/SCL0	SCL0		
97	PL4	CTS	I	RS-232C clear to send input
98	PL5	DTR	O	RS-232C clear to send output
99	PL6/UC0	-	-	-
100	VSS	GND	-	Ground

No.	Mark	Pin Name	I/O	Pin Function
101	PK0/TIN0	XVQERST	O	VQE3 reset signal
102	PK1/TIN1	XCSPRO1	-	Serial communication enable of the progressive converter IC
103	PK2/TIN2	XCSVQE5	-	Serial communication enable of VQE5 IC
104	PK3/TIN3	N.C.	-	N.C.
105	PK4/TOT0	44X48	O	DAC and DASP supply clock fs 44/48 selection
106	PK5/TOT1	DI ERR	I	DIR reception error (unlock signal) input
107	PK6/TOT2	XMICON2 AOSEL1	O	Mic center MIX signal for multi CH AV-1/audio DSP switch (front L/R data)
108	PK7/TOT3	AOSEL0	-	AV1 output AOD and AO0 switch
109	VCC3	V+3.3D	-	Power supply
110	VCC2	V+2.5D	-	Power supply
111	PJ0/INT0	XINT0	I	
112	PJ1/INT1	XINT1	I	
113	PJ2/INT2	XIRQ10	I	MY chip interrupt #0
114	PJ3/INT3	XIRQ11	I	MY chip interrupt #1
115	PJ4/INT4	XABUSY	I	Busy signal of DSP process operation "L"
116	PJ5/INT5	THLD	I	Playback speed monitoring signal
117	PJ6/INT6	SBSY	I	Sync. signal of subcode block (period SO+SI "H")
118	PJ7/INT7	N.C.	I	N.C.
119	PI0/SI0	SSI	I	Serial bus data input
120	PI1/SO0	SSO	O	Serial bus data output
121	PI2/SCK0	SSCK	I	Serial bus clock input
122	PI3/SI1	RXD	I	RS-232C RXD
123	PI4/SO1	TXD	O	RS-232C TXD
124	PI5/SCK1	SELMOD	-	Audio DSP mode switch
125	PH0/SI2	RESET2	-	Reset for DSP 2
126	PH1/SO2	XCSADSP1	O	CS for DSP 2
127	PH2/SCK2	XCSSPD	-	Latch signal of serial/parallel IC for generating audio DSP control signal
128	MD0	GND	-	Ground
129	MD1	GND	-	
130	MD2	GND	-	
131	VSS	GND	-	Ground
132	VCC2	V+2.5D	-	Power supply
133	VSS	GND	-	Ground
134	X1	EXTAL	O	
135	X0	XTAL	I	
136	VCC3	V+3.3D	-	Power supply
137	PC0/DREQ2	LFEON RESET1	O	Select Mix to front L/R of LFE element DSP 1 reset
138	PC1/DACK2	XMICON1 AV1/XSDSP	O	Mic front L/R MIX signal for 2 ch AV-1/servo DSP switch
139	PC2/DEOP2	6CHMD	O	DAC output 2 ch/6 ch switch (←XDVRST2)
140	PB0/DREQ0	XDREQ0	I	DMA response output to BY Chip
141	PB1/DACK0	DACK0	O	DMA request input from BY Chip
142	PB2/DEOP0	N.C.	-	N.C.
143	PB3/DREQ1	XDREQ1	I	DMA response output to AV-1 Chip
144	PB4/DACK1	XDACK1	O	DMA request input from AV-1 Chip
145	PB5/DEOP1	XEXCKON	O	ON/OFF switch of DSP external clock
146	PB6/IOWRX	DOISEL1	O	Digital output switch 1 of audio DSP (AV-1. DSP and GND)
147	PB7/IORDX	DOISEL2	O	Digital output switch 2 of audio DSP (AV-1. DSP and GND)
148	VSS	GND	-	Ground
149	PA0/CSOX	XCS20	O	Chip select output to Flash ROM
150	PA1/CS1X	XCS6	O	AV-1 Chip select



No.	Mark	Pin Name	I/O	Pin Function
151	PA2/CS2X	XCS3	O	Chip select of PD4995A (MY Chip)
152	PA3/CS3X	XCS4	O	Chip select of servo DSP
153	PA4/CS4X	XCS23	O	Chip select output to SRAM (1M)
154	PA5/CS5X	N.C.	O	N.C.
155	PA6/CS6X	N.C.	O	N.C.
156	PA7/CS7X	N.C.	O	N.C.
157	VCC3	V+3.3D	-	Power supply
158	VCC2	V+2.5D	-	Power supply
159	NMIX	-	-	V+3.3D fixed
160	HSTX	-	-	V+2.5D fixed
161	INITX	XINIT	I	
162	P80/RDY	RDY	I	
163	P81/BGRNTX	XAMUTE	I	Final stage mute of 2 ch audio output
164	P82/BRQ	XMMUTE	O	Audio multi channel mute
165	P83/RDX	XRD	O	
166	P84/WR0X	XWR0	O	
167	P85/WR1X	XWR1	O	
168	VSS	GND	-	Ground
169	P90/SYSCLK	SYSCLK	O	
170	P91	DFRST	-	DAC reset (for front L/R)
171	P92/MCLK	DFRST1	-	DAC reset (for center, surround and LFE)
172	P93	XCSDf0	O	DAC chip select (← XLAT3)
173	P94/LBAX	XCSDf1	O	DAC chip select for center, surround and LFE
174	P95/BAAX	XAQRST	O	AQE reset
175	P96	XCSAQE	O	AQE chip select
176	P97/WEX	TM ENT	I	Test mode entry

## ■ M65774BFP (DVDM ASSY : IC801)

- MPEG2 Decoder IC
- Block Diagram

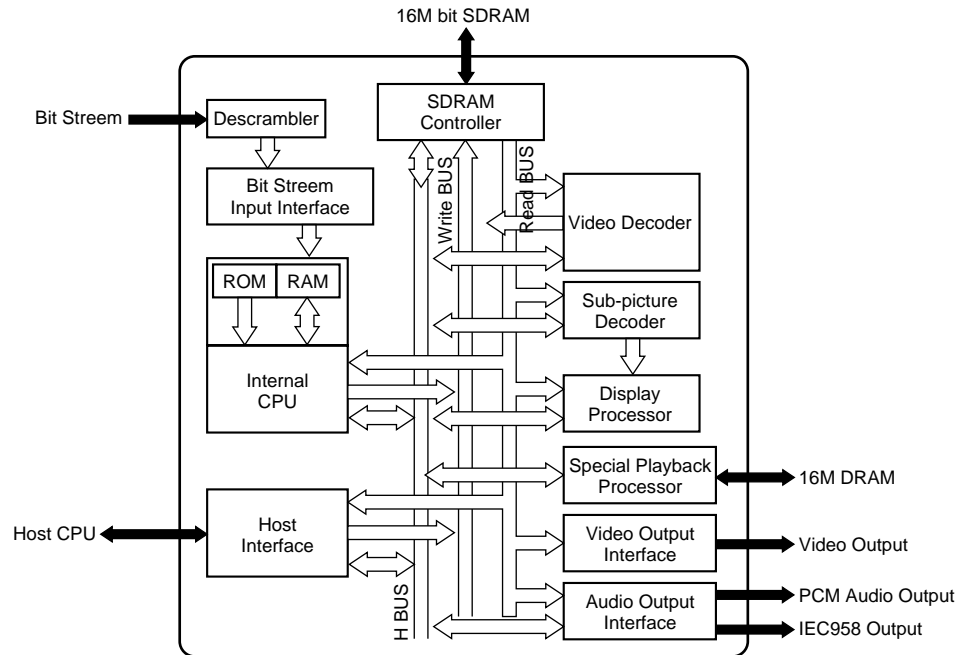

### ● Pin Function

No.	Pin Name	I/O	Pin Function	No.	Pin Name	I/O	Pin Function
1	GND	I	Ground	21	5VDD	I	5V power supply
2	HD0	I/O	Data input and output port	22	HD15	I/O	Data input and output port
3	HD1			23	CS	I	Chip select signal input
4	HD2			24	RE	I	Read Enable signal input
5	HD3			25	WE	I	Write Enable signal input
6	HD4			26	BHE	I	Byte High Enable signal input
7	5VDD	I	5V power supply	27	RDY	O	Acknowledge signal which is indicated the finish of data reading or writing via the host bus
8	VDD	I	Power supply	28	INTR	O	Interrupt request signal against to the external CPU from M65773FP
9	HD5	I/O	Data input and output port	29	GND	I	Ground
10	HD6			30	HA0	I	Address input port
11	HD7			31	HA1		
12	HD8			32	HA2		
13	HD9			33	HA3		
14	GND	I	Ground	34	HA4		
15	HD10	I/O	Data input and output port	35	VDD	I	Power supply
16	HD11			36	5VDD	I	5V power supply
17	HD12			37	HA5	I	Address input port
18	HD13			38	HA6		
19	HD14			39	HA7		
20	VDD	I	Power supply	40	HA8		

No.	Pin Name	I/O	Pin Function	No.	Pin Name	I/O	Pin Function
41	HA9	I	Address input port	83	VDD	I	Power supply
42	GND	I	Ground	84	VSYNC	O	Vertical sync. signal output
43	CDMCK	I	Connect to ground	85	HSYNC	O	Horizontal sync. signal output
44	CDLRCK	I	L/R clock input from CDDSP	86	PICSTRT		
45	CDBCK	I	PCM bit clock input from CDDSP	87	MBSTRT		
46	CDDATA	I	Digital audio interface input	88	MBDATA		
47	VDD	I	Power supply	89	GND	I	Ground
48	CDDIN	I	PCM audio data input from CDDSP	90	PWD	O	Phase comparator output for external sync. operation
49	INT2	O	Interrupt request signal against to the external CPU from M65773FP	91	CSYNC	I	Composite SYNC signal input
50	INT3			92	OSDKEY	O	OSD key flag output
51	DREQ	O	DMA request signal for OSD bitmap transfer	93	PXCLK	O	Pixel clock (27MHz free-running clock)
52	DACK	I	DMA acknowledge signal for OSD bitmap transfer	94	VDD	I	Power supply
53	GND	I	Ground	95	PD7	O	Digital pixel data
54	CLKO	O	27MHz clock output	96	PD6		
55	CLKIN	I	System clock input	97	PD5		
56	AVDD1	I	Analog power supply	98	PD4		
57	AGND1	I	Analog ground	99	GND	I	Ground
58	AGND3						
59	AVDD3	I	Analog power supply	100	PD3	O	Digital pixel data
60	CCAP	I	Connect to ground	101	PD2		
61	AGND2	I	Analog ground	102	PD1		
62	AVDD2	I	Analog power supply	103	PD0		
63	ACLKO	-	Open	104	VDD	I	Power supply
64	ACLKI	I	Audio clock input	105	GND	I	Ground
65	HMODE1	I	Setting pin of host interface operating mode	106	RESET	I	Hardware reset input
66	GND	I	Ground	107	TEST0	I	Connect to ground normally
67	VDD	I	Power supply	108	TEST1		
68	AOD	O	PCM output of audio data	109	TEST2		
69	AO2			110	VDD	I	Power supply
70	AO1			I/O	Data transfer line with DRAM	111	NMD0
71	AO0	112	NMD15				
72	GND	I	Ground	113	NMD1		
73	DOUT1	O	Digital audio interface output	114	NMD14		
74	DOUT0						
75	SDA	-	Open	115	GND	I	Ground
76	SCL	-	Open	116	NMD2	I/O	Data transfer line with DRAM
77	VDD	I	Power supply	117	NMD13		
78	GND	I	Ground	118	NMD3		
79	DACCLK	O	Over-sampling operating clock output	119	NMD12		
80	DOCLK	O	PCM bit clock output	120	VDD	I	Power supply
81	LRCLK	O	Clock output for discriminating the channel (L/R) of PCM audio data	121	NMD4	I/O	Data transfer line with DRAM
82	HMODE0	I	Setting pin of host interface operating mode	122	NMD11		
				123	NMD5		
				124	NMD10		

No.	Pin Name	I/O	Pin Function	No.	Pin Name	I/O	Pin Function		
125	GND	I	Ground	167	MA5	O	Address line with SDRAM		
126	NMD6	I/O	Data transfer line with DRAM	168	GND	I	Ground		
127	NMD9			O	Address line with SDRAM				
128	NMD7								
129	NMD8								
130	VDD					I	Power supply		
131	NCAS0	O	CAS (Column Address Strobe) control line of DRAM	172	MA7	O	Address line with SDRAM		
132	NWE	O	WE control line of DRAM	173	VDD			I	Power supply
133	NCAS1	O	CAS (Column Address Strobe) control line of DRAM	174	MA10				
134	NRAS	O	RAS (Row Address Strobe) control line of DRAM	175	MA8				
135	GND	I	Ground	176	MA11				
136	NMA9	O	Address line with DRAM	177	MA9	I	Ground		
137	NMA8			178	GND				
138	VDD	I	Power supply	179	DCS	O	Chip select of SDRAM		
139	NMA0	O	Address line with DRAM	180	RAS	O	RAS (Row Address Strobe) control line of SDRAM		
140	NMA7			181	CAS	O	CAS (Column Address Strobe) control line of SDRAM		
141	NMA1			182	VDD	I	Power supply		
142	NMA6			183	MCLK	O	Operation clock of SDRAM		
143	GND			I	Ground	184	GND	I	Ground
144	NMA2	O	Address line with DRAM	185	DWE	O	WE control line of SDRAM		
145	NMA5			186	DQMU	O	DQM control line of SDRAM Use for mask of upper byte output.		
146	NMA3			187	DQML	O	DQM control line of SDRAM Use for mask of lower byte output.		
147	NMA4			188	VDD	I	Power supply		
148	VDD			I	Power supply	189	MD7	I/O	Data transfer line with SDRAM
149	BD7	I	Bit stream input port	190	MD8				
150	BD6			191	MD6				
151	GND	I	Ground	192	MD9				
152	BD5	I	Bit stream input port	193	GND	I	Ground		
153	BD4			I/O	Data transfer line with SDRAM				
154	BD3								
155	BD2								
156	VDD			I	Power supply	194	MD5		
157	GND	I	Ground	195	MD10				
158	BD1	I	Bit stream input port	196	MD4				
159	BD0			197	MD11				
160	BCLK	I	Strobe signal (clock) of BD port	198	VDD	I	Power supply		
161	BDEN	I	Indicates the effective or invalid data which is sampled from BD port	199	MD3	I/O	Data transfer line with SDRAM		
162	BDREQ	O	Output permission signal against to the device (channel decoder) which connecting to BD port	200	MD12				
163	VDD	I	Power supply	201	MD2				
164	MA3	O	Address line with SDRAM	202	MD13	I/O	Data transfer line with SDRAM		
165	MA4								
166	MA2								
203	GND			I	Ground				
204	MD1	I/O	Data transfer line with SDRAM	205	MD14				
206	MD0								
207	MD15								
208	VDD			I	Power supply				

# ■ XCA56367PV150 (DVDM ASSY : IC901)

• DVD-Audio decoder

## • Pin Arrangement

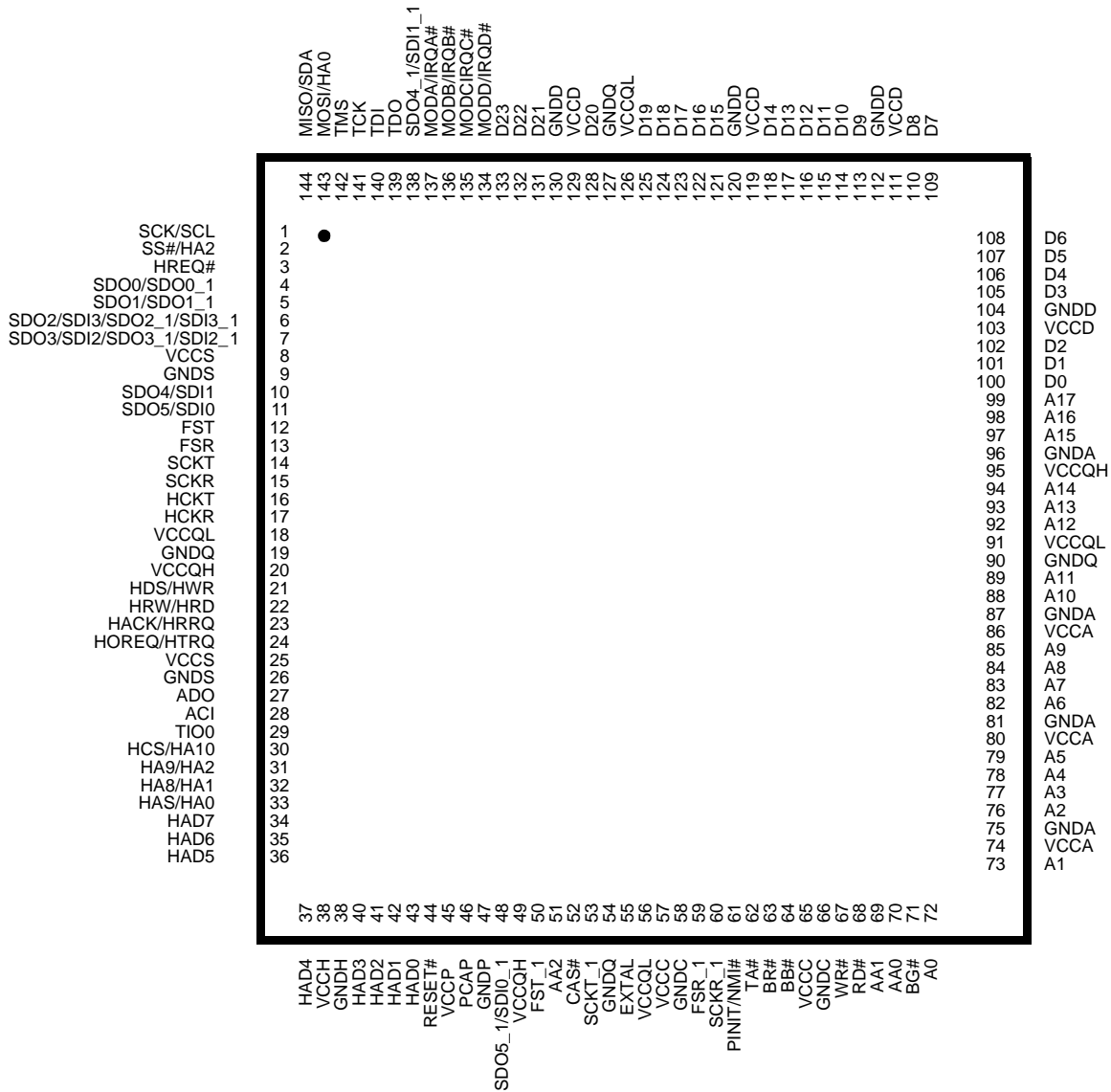

No.	Pin Name	I/O	Function
1	SCK	I	A clock for host serial communication
2	SS	I	for serial communication
3	HREQ#	O	SHI transfer permission information
4	SDO0	O	ESAI Lf/Rf, L/R 2ch data output
5	SDO1	O	ESAI Ls/Rs, (surround system data) output
6	SDO2	O	ESAI center /Lfe output
7	SDO3	O	N.C.
8	VCCS	-	ESSI, SCI, Timer Power
9	GNDS	-	ESSI, SCI, Timer GND
10	SDI1	I	N.C.
11	SDO5	O	down mixture output
12	FST	I/O	LRCK input/output
13	FSR	O	N.C.
14	SCKT	I/O	BCK input/output
15	SCKR	-	N.C.
16	HCKT	I	HCK input
17	HCKR	O	N.C.
18	VCCQL	-	Quiet Core Power 1.8V
19	GNDQ	-	Quiet GND
20	VCCQH	-	Quiet External Power
21	HDS	I	Data strike rope from MyChip
22	HRW	I	Port which selects a data transfer course between Digital Signal Processor as MyChip
23	HACK	O	GPIO output (for error notice to a microcomputer)
24	HOREQ	O	GPIO output (a request to SCRUT)
25	VCCS	-	ESSI, SCI, Timer Power
26	GNDS	-	ESSI, SCI, Timer GND
27	ADO	O	DAX data output
28	ACI	I	A clock for DAX
29	TIO0	O	SHI transfer permission information
30	HCS	O	GPIO output (decode buffer full information) GPIO output (Digital Signal Processor active state information)
31	HA2	I	Host Address Input 2
32	HA1	I	Host Address Input 1
33	HA0	I	Host Address Input 0
34	HAD7	I	Address/Data Bus
35	HAD6		
36	HAD5		

No.	Pin Name	I/O	Function
37	HAD4	I	Address/Data Bus
38	VCCH	-	Host Power
39	GNDH	-	Host GND
40	HAD3	I	Address/Data Bus
41	HAD2		
42	HAD1		
43	HAD0		
44	RESET	I	RESET
45	VCCP	-	PLL POWER
46	PCAP	I	Capacitor connection for PLL loop filter
47	GNDP	-	PLL GND
48	SDIO_1	I	Ls/Rs input
49	VCCQH	-	Quiet External Power
50	FST_1	I	LRCK
51	AA2	O	Chip select for memory
52	CAS	O	N.C.
53	SCKT_1	I	BCK
54	GNDQ	-	Quiet GND
55	EXTAL	I	27MHz clock
56	VCCQL	-	Quiet Core Power
57	VCCC	-	Bus Control Power
58	GNDC	-	Bus Control GND
59	FSR_1	-	N.C.
60	SCKR_1	-	N.C.
61	PINT	I	PLL Intial
62	TA	I	N.C.
63	BR	O	
64	BB	I	
65	VCCC	-	Bus Control Power
66	GNDC	-	Bus Control GND
67	WR	O	Wright signal for memory
68	RD	O	Read signal for memory
69	AA1	O	N.C.
70	AA0	O	
71	BG	I	
72	A0	O	Address Bus

No.	Pin Name	I/O	Function
73	A1	O	Address Bus
74	VCCA	-	Address Bus Power
75	GNDA	-	Address Bus GND
76	A2	O	Address Bus
77	A3		
78	A4		
79	A5		
80	VCCA	-	Address Bus Power
81	GNDA	-	Address Bus GND
82	A6	O	Address Bus
83	A7		
84	A8		
85	A9		
86	VCCA	-	Address Bus Power
87	GNDA	-	Address Bus GND
88	A10	O	Address Bus
89	A11		
90	GNDQ	-	Quiet GND
91	VCCQL	-	Quiet Core Power 1.8V
92	A12	O	Address Bus
93	A13		
94	A14		
95	VCCQH	-	Quiet External Power
96	GNDA	-	Address Bus GND
97	A15	O	Address Bus
98	A16		
99	A17		
100	D0	I/O	Data Bus
101	D1		
102	D2		
103	VCCD	-	Data Bus Power
104	GNDD	-	Data Bus GND
105	D3	I/O	Data Bus
106	D4		
107	D5		
108	D6		



No.	Pin Name	I/O	Function
109	D7	I/O	Data Bus
110	D8		
111	VCCD	-	Data Bus Power
112	GNDD	-	Data Bus GND
113	D9	I/O	Data Bus
114	D10		
115	D11		
116	D12		
117	D13		
118	D14		
119	VCCD	-	Data Bus Power
120	GNDD	-	Data Bus GND
121	D15	I/O	Data Bus
122	D16		
123	D17		
124	D18		
125	D19		
126	VCCQL	-	Quiet Core Power 1.8V
127	GNDQ	-	Quiet GND
128	D20	I/O	Data Bus
129	VCCD	-	Data Bus Power
130	GNDD	-	Data Bus GND
131	D21	I/O	Data Bus
132	D22		
133	D23		
134	MODD	I	Mode of operation choice
135	MODC		
136	MODB		
137	MODA		
138	SDI1_1	I	C/Lfe input
139	TDO	O	JTAG Test Data Output
140	TDI	I	JTAG Test Data Input
141	TCK	I	JTAG Test Clock
142	TMS	I	JTAG Test Mode Select
143	MOSI	I	SH serial data input
144	MOSO	O	SH serial data output

## QA01 : ADV7300KST

- Video Encoder IC

- Pin Arrangement

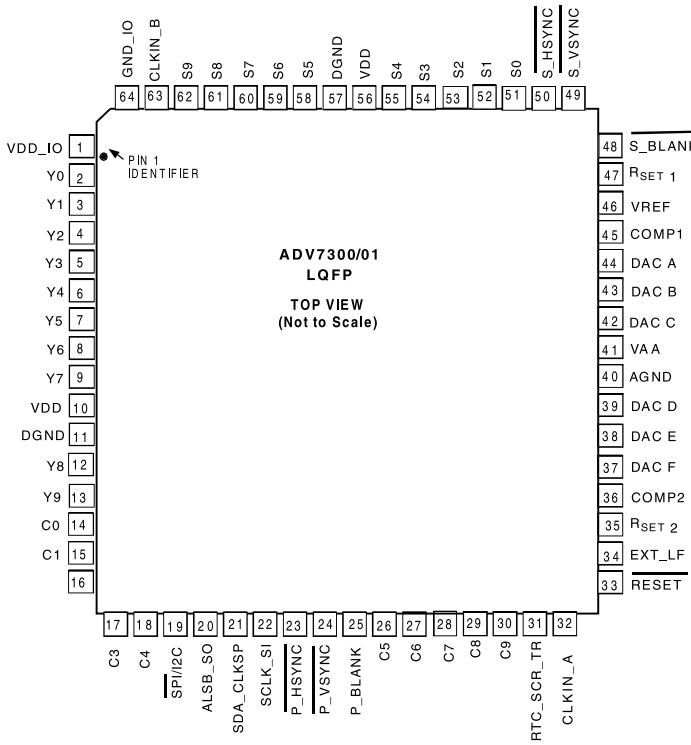

- Pin Function

Pin	Mnemonic	Input/Output	Function
DGND	G		Digital Ground
AGND	G		Analog Ground
GND_IO	G		Digital Ground
CLKIN_B	I		P xel Clock Input. Requires a 27MHz reference clock for Progressive Scan Mode or a 74.25MHz (74.1758MHz) reference clock in HDTV mode. This clock input pin is only used in simultaneous SD and HD mode.
CLKIN_A	I		P xel Clock Input for HD only or SD only modes.
COMP	O		Compensation Pin for DACs. Connect 0.1μF Capacitor from COMP pin to V <sub>AA</sub> .
DAC A	O		CVBS/ GREEN/ Y SD analog output.
DAC B	O		Luma/ BLUE/ U SD analog output.
DAC C	O		Chroma/ RED/ V SD analog output.
DAC D	O		in SD only mode: CVBS/GREEN/ Y analog output in HD only mode and simultaneous HD/SD : Y/ GREEN (HD) analog output.
DAC E	O		in SD only mode: Luma/BLUE/ U analog output in HD only mode and simultaneous HD/SD : Pr/ RED (HD) analog output.

Pin	Mnemonic	Input/Output	Function
DAC F		O	in SD only mode: Chroma/RED/ V analog output in HD only mode and simultaneous HD/SD : Pb/ BLUE (HD) analog output.
P_BLANK		I	Video Blanking Control Signal for HD sync in simultaneous SD/HD mode and HD only mode.
$\overline{P\_HSYNC}$		I	Video Horizontal Sync Control Signal for HD sync in simultaneous SD/HD mode and HD only mode.
$\overline{P\_VSYNC}$		I	Video Vertical Sync Control Signal for HD sync in simultaneous SD/HD mode and HD only mode.
$\overline{S\_BLANK}$		I/O	Video Blanking Control Signal for SD.
$\overline{S\_HSYNC}$		I/O	Video Horizontal Control Signal for SD. Option to o/p SD HSYNC or HD HSYNC in SD Slave Mode 0 and/or any HD mode.
$\overline{S\_VSYNC}$		I/O	Video Blanking Control Signal for SD. Option to o/p SD VSYNC or SD HSYNC in SD Slave Mode 0 and/or any HD mode.
C9-0		I	10-Bit Progressive scan/ HDTV input port for CrCb color data in 4:2:2 input mode. In 4:4:4 input mode this input port is used for the Cb [Blue/U] data. The LSBs are set up on pins C0, C1. In default mode the input on this port is output on DAC E.
Y9-0		I	10-Bit Progressive scan/ HDTV input port for Y data. The LSBs are set up on pins Y0, Y1. In default mode the input on this port is output on DAC D.
S9-S0		I	10-Bit Standard Definition input port. Or Progressive Scan/ HDTV input port for Cr [Red/V] color data in 4:4:4 input mode. The LSBs are set up on pins S0, S1. In default mode the input on this port is output on DAC F.
$\overline{RESET}$		I	This input resets the on-chip timing generator and sets the ADV7300/01 into Default Register setting. Reset is an active low signal.
R <sub>SET1,2</sub>		I	A 1520 Ohms resistor must be connected from this pin to AGND and is used to control the amplitudes of the DAC outputs.
SCL_SI		I	Multifunctional input: MPU Port Serial Interface Clock Input or SPI input.
SDA_CLKSP		I/O	Multifunctional pin: MPU Port Serial Data Input/Output or SPI clock input.
ALSB_SO		I/O	Multifunctional pin. TTL Address Input. This signal sets up the LSB of the MPU address. When this pin is tied low the I2C filter is activated which reduces noise on the I2C interface. When this pin is tied high, the input bandwidth on the I2C lines is increased.
$\overline{SPI/I2C}$		I	SPI output. When this nput pin is brought low, the ADV7300/01 interfaces over the SPI port and uses this input as part of the 4 wire SPI nterface. When this input pin is tied high [Vdd_IO], the ADV7300/01 interfaces over the I2C port.
V <sub>DD,IO</sub>		P	Digital power supply
V <sub>DD</sub>		P	Digital power supply
V <sub>AA</sub>		P	Analog power supply
V <sub>REF</sub>		I/O	Optional External Voltage Reference Input for DACs or Voltage Reference Output (1.235V).
EXT_LF		I	External Loop filter for the internal PLL.
RTC_SCR_TR		I	Multifunctional Input: Real Time Control (RTC) nput, Timing Reset nput, Subcarrier Reset nput.

### 3.4 PCB PARTS LIST

POS. NO	VERS. COLOR	PART NO. (FOR EUR)	PART NO. (MJI)	DESCRIPTION
				DVDM ASSY VWS1513
002A		ZK02AK0210	ZK02AK0210	PCB DVDM ASSY VWS1513
		nsp	nsp	<b>DVDM -SEMICONDUCTORS</b>
IC261		HC10159210	HC10159210	BA4510F
IC281		HC10159210	HC10159210	BA4510F
IC302		HC10159210	HC10159210	BA4510F
IC251		*HC107930R	*HC107930R	BA6664FM
IC481		*HC107940R	*HC107940R	BU2288FV
IC702		*HC107950R	*HC107950R	GM71VS65803CLT-5
IC802		HC10092000	HC10092000	HY57V161610DTC-8
IC902		*HC107960R	*HC107960R	IS61LV6416-12T
IC903		*HC107970R	*HC107970R	IS63LV1024-12T
IC101		*HC105850R	*HC105850R	LA9701M
IC201		*HC105860R	*HC105860R	LC78652W
IC904		HC10412030	HC10412030	LC89051V
IC351		*HC107980R	*HC107980R	M56788AFP
IC804		*HC106040R	*HC106040R	M5M4V18165DTP-6
IC801		*HC107990R	*HC107990R	M65774BFP
IC909		*HC108000R	*HC108000R	MM1561JF
IC601		*HC108010R	*HC108010R	PD6345A
IC701		*HC107650R	*HC107650R	PE5220A
IC111		*HC800020R	*HC800020R	TC74HC4053AFT
IC271		*HC800020R	*HC800020R	TC74HC4053AFT
IC612		HC009405K0	HC009405K0	TC74VHC125FT
IC491		*HC107700R	*HC107700R	TC74VHC153FT
IC906		nsp	nsp	TC74VHC157FT
IC908		nsp	nsp	TC74VHC157FT
IC608		HC007805K0	HC007805K0	TC74VHCT125AFT
IC401		HC007705K0	HC007705K0	TC7SH04FU
IC911		HC007705K0	HC007705K0	TC7SH04FU
IC912		HC007705K0	HC007705K0	TC7SH04FU
IC913		HC007705K0	HC007705K0	TC7SH04FU
IC532		*HC105930R	*HC105930R	TC7SH32FU
IC303		*HC107740R	*HC107740R	TC7SZU04F
IC304		*HC107740R	*HC107740R	TC7SZU04F
IC306		*HC107740R	*HC107740R	TC7SZU04F
IC907		HC009005K0	HC009005K0	TC7WH125FU
IC905		HC009105K0	HC009105K0	TC7WH157FU
IC211		*HC108020R	*HC108020R	TK15404M
IC603		*HS02AKFOR	*HS02AKFOR	VYW1953
IC901		*HC108030R	*HC108030R	XCA56367PV150
Q109		HX100012AY	HX100012AY	2SA1576A
Q210		HX100012AY	HX100012AY	2SA1576A
Q114		HX300012B0	HX300012B0	2SC4081
Q130		HX300012B0	HX300012B0	2SC4081
Q107		BA20035210	BA20035210	DTC114EUA
Q111		BA20035210	BA20035210	DTC114EUA
Q115		BA20035210	BA20035210	DTC114EUA
Q241		BA20035210	BA20035210	DTC114EUA
Q271		BA20035210	BA20035210	DTC114EUA
Q281		BA20035210	BA20035210	DTC114EUA
Q101		BA10011050	BA10011050	HN1A01F
Q102		BA10011050	BA10011050	HN1A01F
Q106		BA10011050	BA10011050	HN1A01F
Q103		nsp	nsp	HN1B04FU
Q141		nsp	nsp	HN1B04FU
Q142		nsp	nsp	HN1B04FU
Q542		nsp	nsp	HN1B04FU
Q543		nsp	nsp	HN1B04FU
Q112		*BA000940R	*BA000940R	HN1C01FU
Q113		*BA000940R	*BA000940R	HN1C01FU
Q108		*BA000950R	*BA000950R	HN1K03FU

NOTE : \*nsp\* PART IS LISTED FOR REFERENCE ONLY, MARANTZ WILL NOT SUPPLY THESE PARTS.

POS. NO	VERS. COLOR	PART NO. (FOR EUR)	PART NO. (MJI)	DESCRIPTION
Q571		*BA000960R	*BA000960R	RN1911
Q117		*BA001030R	*BA001030R	RN4982
Q171		*BA001030R	*BA001030R	RN4982
Q601		*BA001030R	*BA001030R	RN4982
D302		*HZ400010R	*HZ400010R	KV1470
D303		*HZ400010R	*HZ400010R	KV1470
D601		*HZ200100R	*HZ200100R	RB501V-40
				<b>DVDM -COILS AND FILTERS</b>
L946		nsp	nsp	LCYA1R0J2520
L304		nsp	nsp	LCYA1R5J2520
L315		*FC900270R	*FC900270R	CHIP BEADS VTL1082
L418		*FC900270R	*FC900270R	CHIP BEADS VTL1082
L489		*FC900270R	*FC900270R	CHIP BEADS VTL1082
L893		*FC900270R	*FC900270R	CHIP BEADS VTL1082
L516		*FC900270R	*FC900270R	CHIP BEADS VTL1083
L517		*FC900270R	*FC900270R	CHIP BEADS VTL1083
L518		*FC900270R	*FC900270R	CHIP BEADS VTL1083
L519		*FC900270R	*FC900270R	CHIP BEADS VTL1083
L520		*FC900270R	*FC900270R	CHIP BEADS VTL1083
L521		*FC900270R	*FC900270R	CHIP BEADS VTL1083
L522		*FC900270R	*FC900270R	CHIP BEADS VTL1083
L523		*FC900270R	*FC900270R	CHIP BEADS VTL1083
L481		*FC900240R	*FC900240R	CHIP BEADS VTL1084
				<b>DVDM -CAPACITORS</b>
C480		nsp	nsp	CCSRCH100D50
C481		nsp	nsp	CCSRCH100D50
C516		nsp	nsp	CCSRCH100D50
C517		nsp	nsp	CCSRCH100D50
C518		nsp	nsp	CCSRCH100D50
C519		nsp	nsp	CCSRCH100D50
C520		nsp	nsp	CCSRCH100D50
C521		nsp	nsp	CCSRCH100D50
C522		nsp	nsp	CCSRCH100D50
C523		nsp	nsp	CCSRCH100D50
C662		nsp	nsp	CCSRCH100D50
C152		nsp	nsp	CCSRCH101J50
C104		nsp	nsp	CCSRCH150J50
C105		nsp	nsp	CCSRCH150J50
C106		nsp	nsp	CCSRCH150J50
C107		nsp	nsp	CCSRCH150J50
C108		nsp	nsp	CCSRCH150J50
C314		nsp	nsp	CCSRCH150J50
C151		nsp	nsp	CCSRCH270J50
C324		nsp	nsp	CCSRCH331J50
C391		nsp	nsp	CCSRCH331J50
C392		nsp	nsp	CCSRCH331J50
C146		nsp	nsp	CCSRCH390J50
C122		nsp	nsp	CCSRCH391J50
C123		nsp	nsp	CCSRCH391J50
C116		nsp	nsp	CCSRCH470J50
C134		nsp	nsp	CCSRCH470J50
C283		nsp	nsp	CCSRCH470J50
C284		nsp	nsp	CCSRCH470J50
C297		nsp	nsp	CCSRCH470J50
C145		nsp	nsp	CCSRCH560J50
C241		nsp	nsp	CCSRCH560J50
C281		nsp	nsp	CCSRCH5ROC50
C282		nsp	nsp	CCSRCH5ROC50
C286		nsp	nsp	CCSRCH680J50
C117		nsp	nsp	CCSRCH681J50
C360		nsp	nsp	CCSRCH681J50
C124		nsp	nsp	CCSRCH820J50

NOTE : \*nsp\* PART IS LISTED FOR REFERENCE ONLY, MARANTZ WILL NOT SUPPLY THESE PARTS.

POS. NO	VERS. COLOR	PART NO. (FOR EUR)	PART NO. (MJI)	DESCRIPTION
C128		nsp	nsp	CEV101M16
C142		nsp	nsp	CEV101M16
C189		nsp	nsp	CEV101M16
C201		nsp	nsp	CEV101M16
C233		nsp	nsp	CEV101M16
C254		nsp	nsp	CEV101M16
C358		nsp	nsp	CEV101M16
C364		nsp	nsp	CEV101M16
C368		nsp	nsp	CEV101M16
C369		nsp	nsp	CEV101M16
C401		nsp	nsp	CEV101M16
C407		nsp	nsp	CEV101M16
C413		nsp	nsp	CEV101M16
C944		nsp	nsp	CEV101M16
C113		nsp	nsp	CEV220M16
C139		nsp	nsp	CEV220M16
C147		nsp	nsp	CEV221M4
C219		nsp	nsp	CEV221M4
C237		nsp	nsp	CEV221M4
C326		nsp	nsp	CEV221M4
C410		nsp	nsp	CEV221M4
C620		nsp	nsp	CEV221M4
C701		nsp	nsp	CEV221M4
C710		nsp	nsp	CEV221M4
C803		nsp	nsp	CEV221M4
C822		nsp	nsp	CEV221M4
C902		nsp	nsp	CEV221M4
C992		nsp	nsp	CEV221M4
C111		nsp	nsp	CEV470M6R3
C207		nsp	nsp	CEV470M6R3
C140		nsp	nsp	CKSQYB105K10
C223		nsp	nsp	CKSQYB105K10
C224		nsp	nsp	CKSQYB105K10
C264		nsp	nsp	CKSQYB105K10
C312		nsp	nsp	CKSQYB105K10
C209		nsp	nsp	CKSRYB102K50
C211		nsp	nsp	CKSRYB102K50
C216		nsp	nsp	CKSRYB102K50
C275		nsp	nsp	CKSRYB102K50
C313		nsp	nsp	CKSRYB102K50
C351		nsp	nsp	CKSRYB102K50
C133		nsp	nsp	CKSRYB103K50
C136		nsp	nsp	CKSRYB103K50
C203		nsp	nsp	CKSRYB103K50
C220		nsp	nsp	CKSRYB103K50
C225		nsp	nsp	CKSRYB103K50
C234		nsp	nsp	CKSRYB103K50
C239		nsp	nsp	CKSRYB103K50
C261		nsp	nsp	CKSRYB103K50
C320		nsp	nsp	CKSRYB103K50
C321		nsp	nsp	CKSRYB103K50
C322		nsp	nsp	CKSRYB103K50
C330		nsp	nsp	CKSRYB103K50
C591		nsp	nsp	CKSRYB103K50
C619		nsp	nsp	CKSRYB103K50
C705		nsp	nsp	CKSRYB103K50
C707		nsp	nsp	CKSRYB103K50
C943		nsp	nsp	CKSRYB103K50
C947		nsp	nsp	CKSRYB103K50
C101		nsp	nsp	CKSRYB104K16
C103		nsp	nsp	CKSRYB104K16
C118		nsp	nsp	CKSRYB104K16
C119		nsp	nsp	CKSRYB104K16
C120		nsp	nsp	CKSRYB104K16

NOTE : "nsp" PART IS LISTED FOR REFERENCE ONLY, MARANTZ WILL NOT SUPPLY THESE PARTS.

POS. NO	VERS. COLOR	PART NO. (FOR EUR)	PART NO. (MJI)	DESCRIPTION
C212		nsp	nsp	CKSRYB104K16
C213		nsp	nsp	CKSRYB104K16
C227		nsp	nsp	CKSRYB104K16
C231		nsp	nsp	CKSRYB104K16
C248		nsp	nsp	CKSRYB104K16
C249		nsp	nsp	CKSRYB104K16
C250		nsp	nsp	CKSRYB104K16
C251		nsp	nsp	CKSRYB104K16
C255		nsp	nsp	CKSRYB104K16
C263		nsp	nsp	CKSRYB104K16
C315		nsp	nsp	CKSRYB104K16
C317		nsp	nsp	CKSRYB104K16
C208		nsp	nsp	CKSRYB222K50
C210		nsp	nsp	CKSRYB222K50
C271		nsp	nsp	CKSRYB223K50
C272		nsp	nsp	CKSRYB223K50
C273		nsp	nsp	CKSRYB223K50
C274		nsp	nsp	CKSRYB223K50
C266		nsp	nsp	CKSRYB224K10
C206		nsp	nsp	CKSRYB472K50
C214		nsp	nsp	CKSRYB472K50
C242		nsp	nsp	CKSRYB472K50
C357		nsp	nsp	CKSRYB472K50
C946		nsp	nsp	CKSRYB473K50
C102		nsp	nsp	CKSRYF104Z25
C121		nsp	nsp	CKSRYF104Z25
C138		nsp	nsp	CKSRYF104Z25
C143		nsp	nsp	CKSRYF104Z25
C154		nsp	nsp	CKSRYF104Z25
C256		nsp	nsp	CKSRYF104Z25
C279		nsp	nsp	CKSRYF104Z25
C285		nsp	nsp	CKSRYF104Z25
C332		nsp	nsp	CKSRYF104Z25
C353		nsp	nsp	CKSRYF104Z25
C359		nsp	nsp	CKSRYF104Z25
C365		nsp	nsp	CKSRYF104Z25
C366		nsp	nsp	CKSRYF104Z25
C402		nsp	nsp	CKSRYF104Z25
C475		nsp	nsp	CKSRYF104Z25
C476		nsp	nsp	CKSRYF104Z25
C477		nsp	nsp	CKSRYF104Z25
C609		nsp	nsp	CKSRYF104Z25
C768		nsp	nsp	CKSRYF104Z25
C772		nsp	nsp	CKSRYF104Z25
C773		nsp	nsp	CKSRYF104Z25
C109		nsp	nsp	CKSRYF105Z10
C114		nsp	nsp	CKSRYF105Z10
C115		nsp	nsp	CKSRYF105Z10
C125		nsp	nsp	CKSRYF105Z10
C130		nsp	nsp	CKSRYF105Z10
C131		nsp	nsp	CKSRYF105Z10
C144		nsp	nsp	CKSRYF105Z10
C148		nsp	nsp	CKSRYF105Z10
C150		nsp	nsp	CKSRYF105Z10
C160		nsp	nsp	CKSRYF105Z10
C200		nsp	nsp	CKSRYF105Z10
C202		nsp	nsp	CKSRYF105Z10
C204		nsp	nsp	CKSRYF105Z10
C215		nsp	nsp	CKSRYF105Z10
C217		nsp	nsp	CKSRYF105Z10
C221		nsp	nsp	CKSRYF105Z10
C222		nsp	nsp	CKSRYF105Z10
C226		nsp	nsp	CKSRYF105Z10
C230		nsp	nsp	CKSRYF105Z10

NOTE : "nsp" PART IS LISTED FOR REFERENCE ONLY, MARANTZ WILL NOT SUPPLY THESE PARTS.

POS. NO	VERS. COLOR	PART NO. (FOR EUR)	PART NO. (MJI)	DESCRIPTION
C232		nsp	nsp	CKSRYP105Z10
C236		nsp	nsp	CKSRYP105Z10
C253		nsp	nsp	CKSRYP105Z10
C258		nsp	nsp	CKSRYP105Z10
C265		nsp	nsp	CKSRYP105Z10
C298		nsp	nsp	CKSRYP105Z10
C299		nsp	nsp	CKSRYP105Z10
C310		nsp	nsp	CKSRYP105Z10
C319		nsp	nsp	CKSRYP105Z10
C328		nsp	nsp	CKSRYP105Z10
C329		nsp	nsp	CKSRYP105Z10
C361		nsp	nsp	CKSRYP105Z10
C393		nsp	nsp	CKSRYP105Z10
C400		nsp	nsp	CKSRYP105Z10
C404		nsp	nsp	CKSRYP105Z10
C406		nsp	nsp	CKSRYP105Z10
C408		nsp	nsp	CKSRYP105Z10
C411		nsp	nsp	CKSRYP105Z10
C451		nsp	nsp	CKSRYP105Z10
C491		nsp	nsp	CKSRYP105Z10
C532		nsp	nsp	CKSRYP105Z10
C542		nsp	nsp	CKSRYP105Z10
C543		nsp	nsp	CKSRYP105Z10
C602		nsp	nsp	CKSRYP105Z10
C603		nsp	nsp	CKSRYP105Z10
C604		nsp	nsp	CKSRYP105Z10
C605		nsp	nsp	CKSRYP105Z10
C607		nsp	nsp	CKSRYP105Z10
C608		nsp	nsp	CKSRYP105Z10
C610		nsp	nsp	CKSRYP105Z10
C613		nsp	nsp	CKSRYP105Z10
C614		nsp	nsp	CKSRYP105Z10
C615		nsp	nsp	CKSRYP105Z10
C616		nsp	nsp	CKSRYP105Z10
C618		nsp	nsp	CKSRYP105Z10
C622		nsp	nsp	CKSRYP105Z10
C626		nsp	nsp	CKSRYP105Z10
C628		nsp	nsp	CKSRYP105Z10
C631		nsp	nsp	CKSRYP105Z10
C657		nsp	nsp	CKSRYP105Z10
C658		nsp	nsp	CKSRYP105Z10
C703		nsp	nsp	CKSRYP105Z10
C704		nsp	nsp	CKSRYP105Z10
C708		nsp	nsp	CKSRYP105Z10
C715		nsp	nsp	CKSRYP105Z10
C721		nsp	nsp	CKSRYP105Z10
C727		nsp	nsp	CKSRYP105Z10
C730		nsp	nsp	CKSRYP105Z10
C740		nsp	nsp	CKSRYP105Z10
C743		nsp	nsp	CKSRYP105Z10
C749		nsp	nsp	CKSRYP105Z10
C753		nsp	nsp	CKSRYP105Z10
C757		nsp	nsp	CKSRYP105Z10
C762		nsp	nsp	CKSRYP105Z10
C774		nsp	nsp	CKSRYP105Z10
C775		nsp	nsp	CKSRYP105Z10
C776		nsp	nsp	CKSRYP105Z10
C777		nsp	nsp	CKSRYP105Z10
C778		nsp	nsp	CKSRYP105Z10
C783		nsp	nsp	CKSRYP105Z10
C796		nsp	nsp	CKSRYP105Z10
C804		nsp	nsp	CKSRYP105Z10
C807		nsp	nsp	CKSRYP105Z10
C808		nsp	nsp	CKSRYP105Z10

NOTE : "nsp" PART IS LISTED FOR REFERENCE ONLY, MARANTZ WILL NOT SUPPLY THESE PARTS.



POS. NO	VERS. COLOR	PART NO. (FOR EUR)	PART NO. (MJI)	DESCRIPTION
C810		nsp	nsp	CKSRYP105Z10
C812		nsp	nsp	CKSRYP105Z10
C820		nsp	nsp	CKSRYP105Z10
C821		nsp	nsp	CKSRYP105Z10
C823		nsp	nsp	CKSRYP105Z10
C824		nsp	nsp	CKSRYP105Z10
C825		nsp	nsp	CKSRYP105Z10
C826		nsp	nsp	CKSRYP105Z10
C827		nsp	nsp	CKSRYP105Z10
C828		nsp	nsp	CKSRYP105Z10
C829		nsp	nsp	CKSRYP105Z10
C830		nsp	nsp	CKSRYP105Z10
C835		nsp	nsp	CKSRYP105Z10
C836		nsp	nsp	CKSRYP105Z10
C838		nsp	nsp	CKSRYP105Z10
C841		nsp	nsp	CKSRYP105Z10
C842		nsp	nsp	CKSRYP105Z10
C843		nsp	nsp	CKSRYP105Z10
C847		nsp	nsp	CKSRYP105Z10
C848		nsp	nsp	CKSRYP105Z10
C856		nsp	nsp	CKSRYP105Z10
C859		nsp	nsp	CKSRYP105Z10
C862		nsp	nsp	CKSRYP105Z10
C863		nsp	nsp	CKSRYP105Z10
C865		nsp	nsp	CKSRYP105Z10
C867		nsp	nsp	CKSRYP105Z10
C873		nsp	nsp	CKSRYP105Z10
C874		nsp	nsp	CKSRYP105Z10
C877		nsp	nsp	CKSRYP105Z10
C880		nsp	nsp	CKSRYP105Z10
C882		nsp	nsp	CKSRYP105Z10
C883		nsp	nsp	CKSRYP105Z10
C888		nsp	nsp	CKSRYP105Z10
C894		nsp	nsp	CKSRYP105Z10
C898		nsp	nsp	CKSRYP105Z10
C901		nsp	nsp	CKSRYP105Z10
C903		nsp	nsp	CKSRYP105Z10
C905		nsp	nsp	CKSRYP105Z10
C906		nsp	nsp	CKSRYP105Z10
C907		nsp	nsp	CKSRYP105Z10
C908		nsp	nsp	CKSRYP105Z10
C911		nsp	nsp	CKSRYP105Z10
C912		nsp	nsp	CKSRYP105Z10
C913		nsp	nsp	CKSRYP105Z10
C918		nsp	nsp	CKSRYP105Z10
C918		nsp	nsp	CKSRYP105Z10
C920		nsp	nsp	CKSRYP105Z10
C923		nsp	nsp	CKSRYP105Z10
C924		nsp	nsp	CKSRYP105Z10
C925		nsp	nsp	CKSRYP105Z10
C926		nsp	nsp	CKSRYP105Z10
C929		nsp	nsp	CKSRYP105Z10
C933		nsp	nsp	CKSRYP105Z10
C934		nsp	nsp	CKSRYP105Z10
C938		nsp	nsp	CKSRYP105Z10
C942		nsp	nsp	CKSRYP105Z10
C945		nsp	nsp	CKSRYP105Z10
C948		nsp	nsp	CKSRYP105Z10
C949		nsp	nsp	CKSRYP105Z10
C956		nsp	nsp	CKSRYP105Z10
C957		nsp	nsp	CKSRYP105Z10
C965		nsp	nsp	CKSRYP105Z10
C974		nsp	nsp	CKSRYP105Z10
C980		nsp	nsp	CKSRYP105Z10

NOTE : "nsp" PART IS LISTED FOR REFERENCE ONLY, MARANTZ WILL NOT SUPPLY THESE PARTS.

POS. NO	VERS. COLOR	PART NO. (FOR EUR)	PART NO. (MJI)	DESCRIPTION
C986		nsp	nsp	CKSRYF105Z10
C988		nsp	nsp	CKSRYF105Z10
C991		nsp	nsp	CKSRYF105Z10
C993		nsp	nsp	CKSRYF105Z10
C994		nsp	nsp	CKSRYF105Z10
C995		nsp	nsp	CKSRYF105Z10
C129		nsp	nsp	100µF/6.3V VCH1194
C149		nsp	nsp	100µF/6.3V VCH1194
C403		nsp	nsp	100µF/6.3V VCH1194
C205		nsp	nsp	150µF/4V VCH1195
C405		nsp	nsp	150µF/4V VCH1195
C452		nsp	nsp	150µF/4V VCH1195
C472		nsp	nsp	150µF/4V VCH1195
C601		nsp	nsp	150µF/4V VCH1195
C623		nsp	nsp	150µF/4V VCH1195
C700		nsp	nsp	150µF/4V VCH1195
C702		nsp	nsp	150µF/4V VCH1195
C801		nsp	nsp	150µF/4V VCH1195
C840		nsp	nsp	150µF/4V VCH1195
C904		nsp	nsp	150µF/4V VCH1195
C941		nsp	nsp	150µF/4V VCH1195
C996		nsp	nsp	150µF/4V VCH1195
C367		nsp	nsp	33µF/16V VCH1197
				<b>DVDM -RESISTORS</b>
R800		nsp	nsp	RAB4C0R0J
R895		nsp	nsp	RAB4C0R0J
R543		nsp	nsp	R744 RAB4C103J
R545		nsp	nsp	R744 RAB4C103J
R631		nsp	nsp	R744 RAB4C103J
R714		nsp	nsp	R744 RAB4C103J
R903		nsp	nsp	RAB4C103J
R931		nsp	nsp	RAB4C103J
R934		nsp	nsp	RAB4C103J
R940		nsp	nsp	RAB4C103J
R121		nsp	nsp	RAB4C220J
R757		nsp	nsp	RAB4C220J
R763		nsp	nsp	RAB4C220J
R790		nsp	nsp	RAB4C220J
R868		nsp	nsp	RAB4C220J
R873		nsp	nsp	RAB4C220J
R123		nsp	nsp	RAB4C470J
R202		nsp	nsp	RS1/10S101J
R341		nsp	nsp	RS1/10S101J
R126		nsp	nsp	RS1/10S220J
R127		nsp	nsp	RS1/10S220J
R128		nsp	nsp	RS1/10S220J
R129		nsp	nsp	RS1/10S220J
R176		nsp	nsp	RS1/10S220J
R177		nsp	nsp	RS1/10S220J
R178		nsp	nsp	RS1/10S220J
R179		nsp	nsp	RS1/10S220J
R287		nsp	nsp	RS1/16S1002F
R364		nsp	nsp	RS1/16S1003F
R369		nsp	nsp	RS1/16S1003F
R373		nsp	nsp	RS1/16S1003F
R375		nsp	nsp	RS1/16S1003F
R289		nsp	nsp	RS1/16S1503F
R358		nsp	nsp	RS1/16S1503F
R361		nsp	nsp	RS1/16S1503F
R288		nsp	nsp	RS1/16S2201F
R357		nsp	nsp	RS1/16S6802F
R362		nsp	nsp	RS1/16S6802F
R363		nsp	nsp	RS1/16S6802F

NOTE : "nsp" PART IS LISTED FOR REFERENCE ONLY, MARANTZ WILL NOT SUPPLY THESE PARTS.

POS. NO	VERS. COLOR	PART NO. (FOR EUR)	PART NO. (MJI)	DESCRIPTION
R368		nsp	nsp	RS1/16S6802F
R372		nsp	nsp	RS1/16S6802F
R374		nsp	nsp	RS1/16S6802F
R257		nsp	nsp	1.0Ω 1/4W VCN1127
R258		nsp	nsp	2.2Ω 1/4W VCN1128
R259		nsp	nsp	2.2Ω 1/4W VCN1128
Other Resistors		nsp	nsp	RS1/16S&&&J
<b>DVDM -OTHERS</b>				
CN602		*YJ002530R	*YJ002530R	FFC CONNECTOR DKN1196
CN104		*YJ002540R	*YJ002540R	4P CONNECTOR DKN1223
CN103		nsp	nsp	CONNECTOR S5B-PH-SM3
		nsp	nsp	FLEXIBLE CABLE VDA1681
CN101		*YJ002550R	*YJ002550R	FFC CONNECTOR VKN1787
CN401		*YJ002560R	*YJ002560R	B TO B CONNECTOR 40P VKN1788
CN501		*YJ002560R	*YJ002560R	B TO B CONNECTOR 40P VKN1788
CN105		*YJ002570R	*YJ002570R	12P CONNECTOR VKN1795
X481		*JX000940R	*JX000940R	27.000MHz VSS1159
X601		*JX000950R	*JX000950R	16.5MHz VSS1160

NOTE : "nsp" PART IS LISTED FOR REFERENCE ONLY, MARANTZ WILL NOT SUPPLY THESE PARTS.

NOTES: ● Parts marked by "NSP" are generally unavailable because they are not in our Master Spare Parts List.

● The  $\Delta$  mark found on some component parts indicates the importance of the safety factor of the part. Therefore, when replacing, be sure to use parts of identical designation.

● When ordering resistors, first convert resistance values into code form as shown in the following examples.

Ex.1 When there are 2 effective digits (any digit apart from 0), such as 560 ohm and 47k ohm (tolerance is shown by J=5%, and K=10%).

560 Ω → 56 × 10<sup>1</sup> → 561 ..... RD1/4PU  $\boxed{5} \boxed{6} \boxed{1} J$   
47k Ω → 47 × 10<sup>3</sup> → 473 ..... RD1/4PU  $\boxed{4} \boxed{7} \boxed{3} J$   
0.5 Ω → R50 ..... RN2H  $\boxed{R} \boxed{5} \boxed{0} K$   
1 Ω → 1R0 ..... RS1P  $\boxed{1} \boxed{R} \boxed{0} K$

Ex.2 When there are 3 effective digits (such as in high precision metal film resistors).

5.62k Ω → 562 × 10<sup>1</sup> → 5621 ..... RN1/4PC  $\boxed{5} \boxed{6} \boxed{2} \boxed{1} F$