

Service Manual

ER3000/F1S

DVD Receiver

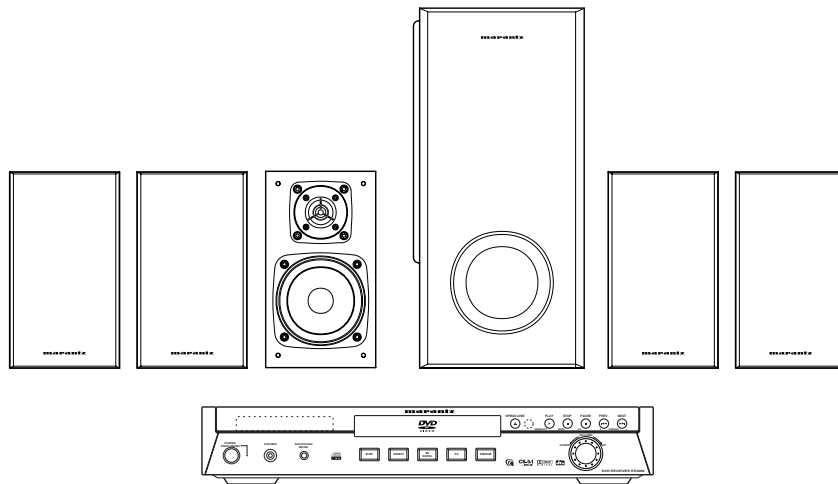

CS-5.1
by SRS (S)



TABLE OF CONTENTS

1. MAIN UNIT & SPEAKERS	
1.1 TECHNICAL SPECIFICATIONS	1
1.2 WIRING DIAGRAM	3
1.3 BLOCK DIAGRAM	5
1.4 SCHEMATIC DIAGRAM AND PARTS LOCATION	7
1.5 MICROPROCESSOR AND IC DATA	27
1.6 TECHNICAL DESCRIPTION	39
1.7 ADJUSTMENT PROCEDURE	40
1.8 EXPLODED VIEW AND PARTS LIST	47
1.9 TAKING OUT THE DISC FOR EMERGENCY	55
1.10 ELECTRICAL PARTS LIST	50
2. DB-VLD210 (DVD Loader for MARANTZ)	
3. DB-VPB210 / 211 / 212 / 213 / 214 / 215 (DVD PCB Module for MARANTZ)	

修理の際は、必ず取扱説明書を準備し操作方法を確認の上作業を行って下さい。

marantz®

ER3000

MARANTZ DESIGN AND SERVICE

Using superior design and selected high grade components, **MARANTZ** company has created the ultimate in stereo sound. Only original **MARANTZ** parts can insure that your **MARANTZ** product will continue to perform to the specifications for which it is famous.

Parts for your **MARANTZ** equipment are generally available to our National Marantz Subsidiary or Agent.

ORDERING PARTS :

Parts can be ordered either by mail or by Fax.. In both cases, the correct part number has to be specified.

The following information must be supplied to eliminate delays in processing your order :

1. Complete address
2. Complete part numbers and quantities required
3. Description of parts
4. Model number for which part is required
5. Way of shipment
6. Signature : any order form or Fax. must be signed, otherwise such part order will be considered as null and void.

USA

MARANTZ AMERICA, INC.
1100 MAPLEWOOD DRIVE
ITASCA, IL. 60143
USA
PHONE : 630 - 741 - 0300
FAX : 630 - 741 - 0301

EUROPE / TRADING

MARANTZ EUROPE B.V.
P.O.BOX 80002, BUILDING SFF2
5600 JB EINDHOVEN
THE NETHERLANDS
PHONE : +31 - 40 - 2732241
FAX : +31 - 40 - 2735578

BRAZIL

PHILIPS DA AMAZONIA IND. ELET. ITDA
CENTRO DE INFORMACOES AO
CEP 04698-970
SAO PAULO, SP, BRAZIL
PHONE : 0800 - 123123(Discagem Direta Gratuita)
FAX : +55 11 534. 8988

PROFESSIONAL AMERICAS

SUPERSCOPE TECHNOLOGIES, INC.
MARANTZ PROFESSIONAL PRODUCTS
2640 WHITE OAK CIRCLE, SUITE A
AURORA, ILLINOIS 60504 USA
PHONE : 630 - 820 - 4800
FAX : 630 - 820 - 8103

PROFESSIONAL AUSTRALIA

TECHNICAL AUDIO GROUP PTY, LTD
558 DARLING STREET,
BALMAIN, NSW 2041,
AUSTRALIA
PHONE : 61 - 2 - 9810 - 5300
FAX : 61 - 2 - 9810 - 5355

CANADA

LENBROOK INDUSTRIES LIMITED
633 GRANITE COURT,
PICKERING, ONTARIO L1W 3K1
CANADA
PHONE : 905 - 831 - 6333
FAX : 905 - 831 - 6936

AUSTRALIA

QualiFI Pty Ltd,
24 LIONEL ROAD,
MT. WAVERLEY VIC 3149
AUSTRALIA
PHONE : +61 - (0)3 - 9543 - 1522
FAX : +61 - (0)3 - 9543 - 3677

THAILAND

MRZ STANDARD CO.,LTD
746 - 754 MAHACHAI ROAD.,
WANGBURAPAPIROM, PHRANAKORN,
BANGKOK, 10200 THAILAND
PHONE : +66 - 2 - 222 9181
FAX : +66 - 2 - 224 6795

SINGAPORE

WO KEE HONG DISTRIBUTION PTE LTD
130 JOO SENG ROAD
#03-02 OLIVINE BUILDING
SINGAPORE 368357
PHONE : +65 858 5535 / +65 381 8621
FAX : +65 858 6078

NEW ZEALAND

WILDASH AUDIO SYSTEMS NZ
14 MALVERN ROAD MT ALBERT
AUCKLAND NEW ZEALAND
PHONE : +64 - 9 - 8451958
FAX : +64 - 9 - 8463554

TAIWAN

PAI- YUING CO., LTD.
6 TH FL NO, 148 SUNG KIANG ROAD,
TAIPEI, 10429, TAIWAN R.O.C.
PHONE : +886 - 2 - 25221304
FAX : +886 - 2 - 25630415

MALAYSIA

WO KEE HONG ELECTRONICS SDN. BHD.
SUITE 8.1, LEVEL 8, MENARA GENESIS,
NO. 33, JALAN SULTAN ISMAIL,
50250 KUALA LUMPUR, MALAYSIA
PHONE : +60 3 - 2457677
FAX : +60 3 - 2458180

JAPAN *Technical*

MARANTZ JAPAN, INC.
35- 1, 7- CHOME, SAGAMIONO
SAGAMIHARA - SHI, KANAGAWA
JAPAN 228-8505
PHONE : +81 42 748 1013
FAX : +81 42 741 9190

日本マランツ株式会社

本社 〒228-8505
神奈川県相模原市相模大野7-35-1
営業本部 〒150-0022
東京都渋谷区恵比寿南1-11-9

KOREA

MK ENTERPRISES LTD.
ROOM 604/605, ELECTRO-OFFICETEL, 16-58,
3GA, HANGANG-RO, YONGSAN-KU, SEOUL
KOREA
PHONE : +822 - 3232 - 155
FAX : +822 - 3232 - 154

SHOCK, FIRE HAZARD SERVICE TEST :

CAUTION : After servicing this appliance and prior to returning to customer, measure the resistance between either primary AC cord connector pins (with unit NOT connected to AC mains and its Power switch ON), and the face or Front Panel of product and controls and chassis bottom.

Any resistance measurement less than 1 Megohms should cause unit to be repaired or corrected before AC power is applied, and verified before it is return to the user/customer.

Ref. UL Standard No. 1492.

In case of difficulties, do not hesitate to contact the Technical Department at above mentioned address.

1.1 TECHNICAL SPECIFICATIONS

仕様

DSP部

DSPモードドルビーデジタル、ドルビープロロジック、DTS、サークルサラウンド(CS5.1)、MPEG2 AAC

オーディオ部

パワーアンプ部

実用最大出力(6Ω、EIAJ)

フロント 50W + 50W

センター 50W

サラウンド 50W + 50W

ウーファー 50W

定格出力

フロント 35W + 35W (20Hz ~ 20kHz、T.H.D 0.8%、負荷 6Ω)

センター 35W (20Hz ~ 20kHz、T.H.D 0.8%、負荷 6Ω)

サラウンド 35W + 35W (20Hz ~ 20kHz、T.H.D 0.8%、負荷 6Ω)

ウーファー 35W (63Hz、T.H.D 0.8%、負荷 6Ω)

アナログ部

入力感度/入力インピーダンス

ビデオ、BS DIGITAL、テレビ 420 mV / 22 kΩ

定格出力/インピーダンス

ビデオ 370 mV / 1 kΩ

サブウーファー出力 5.5 V / 1 kΩ

ビデオ部

入力感度/入力インピーダンス(コンポジット信号)

ビデオ、BS DIGITAL 1 V p-p、75Ω

入力感度/入力インピーダンス(Sビデオ信号)

ビデオ、BS DIGITAL 輝度(Y)信号 : 1 V p-p、75Ω、色(C)信号 : 0.286V p-p、75Ω

定格出力/インピーダンス(コンポジット信号)

ビデオ、モニター 1 V p-p、75Ω

定格出力/インピーダンス(Sビデオ信号)

ビデオ、モニター 輝度(Y)信号 : 1 V p-p、75Ω、色(C)信号 : 0.286V p-p、75Ω

定格出力/インピーダンス(コンポーネント信号)

DVD D1 輝度(Y)信号 : 1 V p-p、75Ω、色(CB/CR)信号 : 0.7V p-p、75Ω

FMチューナー部

回路方式 PLL デジタル周波数シンセサイザークォーツロック方式

受信周波数 76.0 MHz ~ 90.0 MHz (100 kHz ステップ)

実用感度(モノラル) 1.6 μV / 15.3dBf

高調波歪率 モノラル 0.3%

ステレオ 0.5%

S/N比 モノラル 70 dB

ステレオ 65 dB

AMチューナー部

回路方式 PLL デジタル周波数シンセサイザークォーツロック方式

受信周波数 531 kHz ~ 1602 kHz (9 kHzステップ)

実用感度(ループアンテナ) 60 dBμV/m

S/N比 50 dB

高調波歪率 0.7%

DVD部

再生可能メディア DVD、ビデオ CD(8/12cm)、CD-DA、CD-R、CD-RW(8/12cm)

音声特性(DVD リニア音声再生時、ビデオ音声出力端子)

S/N比 90 dB (EIAJ)

周波数特性 20 Hz ~ 20 kHz (+0 / -1 dB)

ダイナミックレンジ 90 dB (EIAJ)

全高調波歪率 0.01 % (EIAJ)

映像特性

信号方式 EIAJ標準 NTSCカラー方式

水平解像度 500 本以上(DVD再生時)

スピーカー部

フロント、センター、サラウンドスピーカー

2Way 密閉防磁型ツイーター	25mm ドーム型
ウーファー	90mm コーン型

インピーダンス 6 Ω

定格入力 40W

最大入力 100W

外形寸法 幅 107 x 高さ 191 x 奥行 137 mm

質量 各1.5 Kg

サブウーファー

バスレフ型 20cm コーン型(防磁)

インピーダンス 6 Ω

定格入力 40W

最大入力 80W

外形寸法 幅 160 x 高さ 350 x 奥行 320 mm

質量 5.9 Kg

一般事項

消費電力/待機時電力 120W/ 4 W以下(電気用品取締法)

外形寸法 幅 435 x 高さ 75.8 x 奥行 302.7 mm

質量 本体5.3 Kg

許容動作温度 5 ~ 35°C

付属品

・リモコン送信機 (RC3000ERF) 1 個

・単3形乾電池 2 個

・スピーカーケーブル 5 m x 4本、15 m x 2本

・ビデオケーブル 1本(ピンプラグ x 1 - ピンプラグ x 1)

・AMループアンテナ 1 個

・FMワイヤーアンテナ 1 個

・FMアンテナプラグ 1 個

・スピーカー 5 個

・サブウーファー 1 個

・取扱説明書 1 部

・保証書 1 部

※仕様および外観は、改良のため、予告なく変更することがあります。

1.2 WIRING DIAGRAM

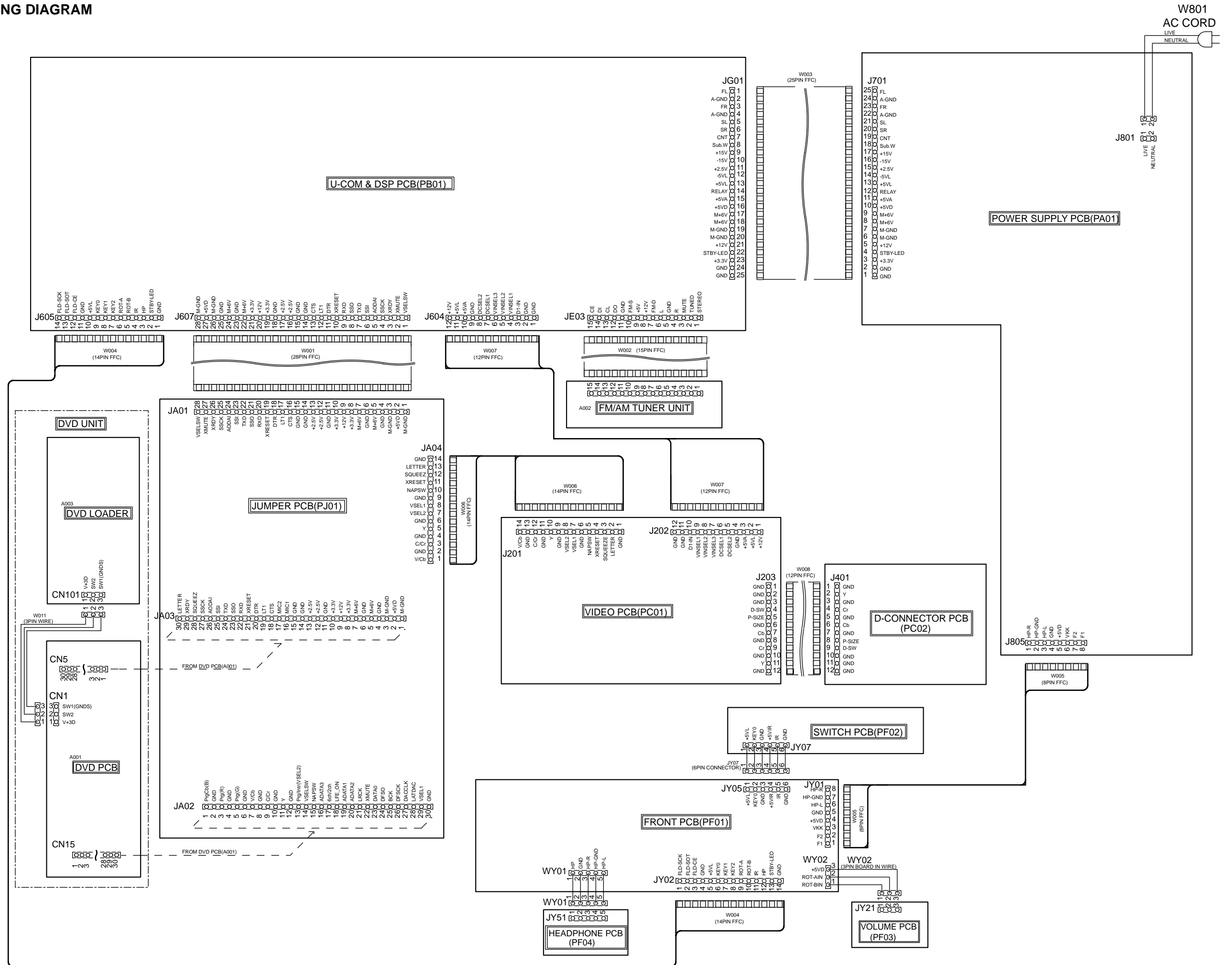

1.3 BLOCK DIAGRAM

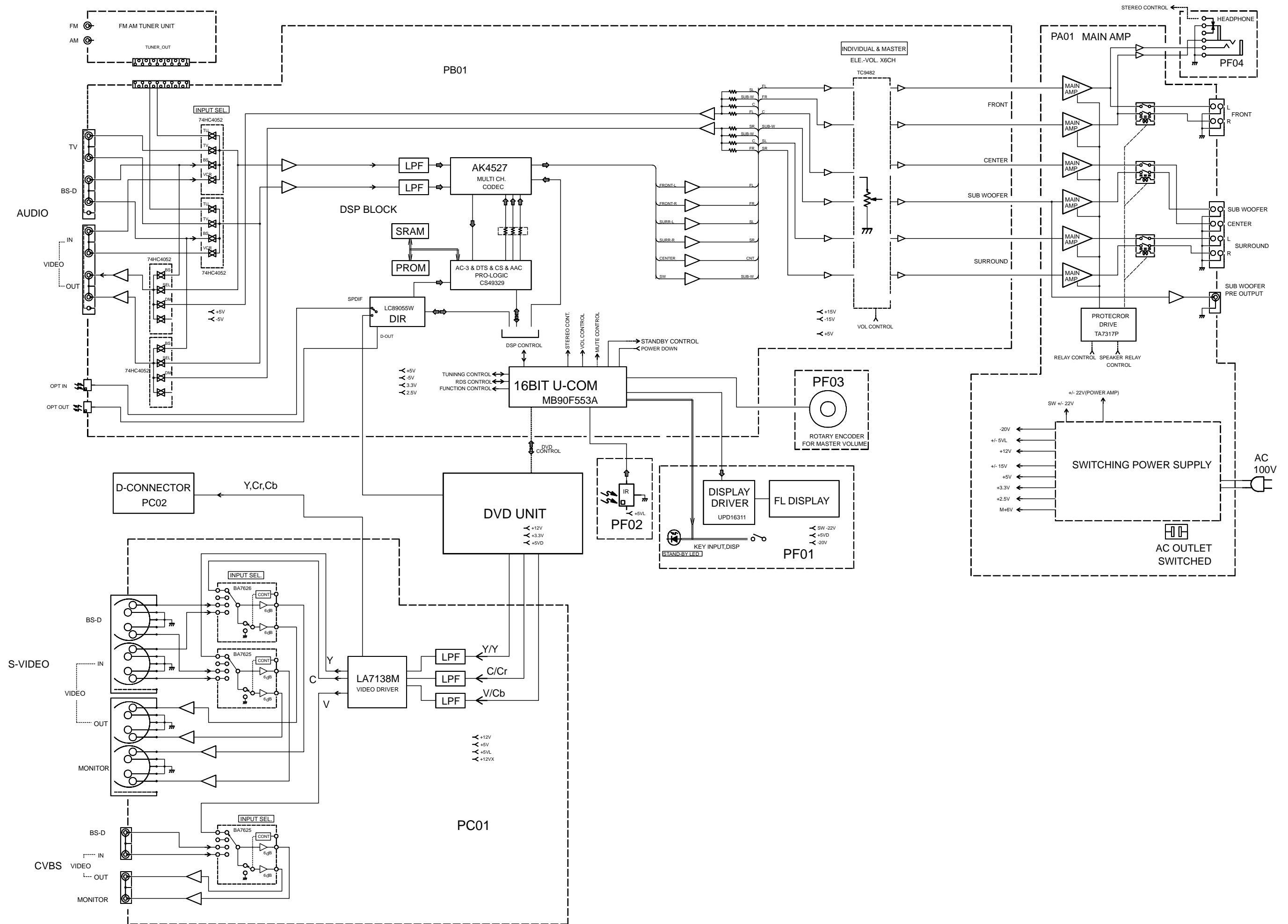

1.4 SCHEMATIC DIAGRAM AND PARTS LOCATION

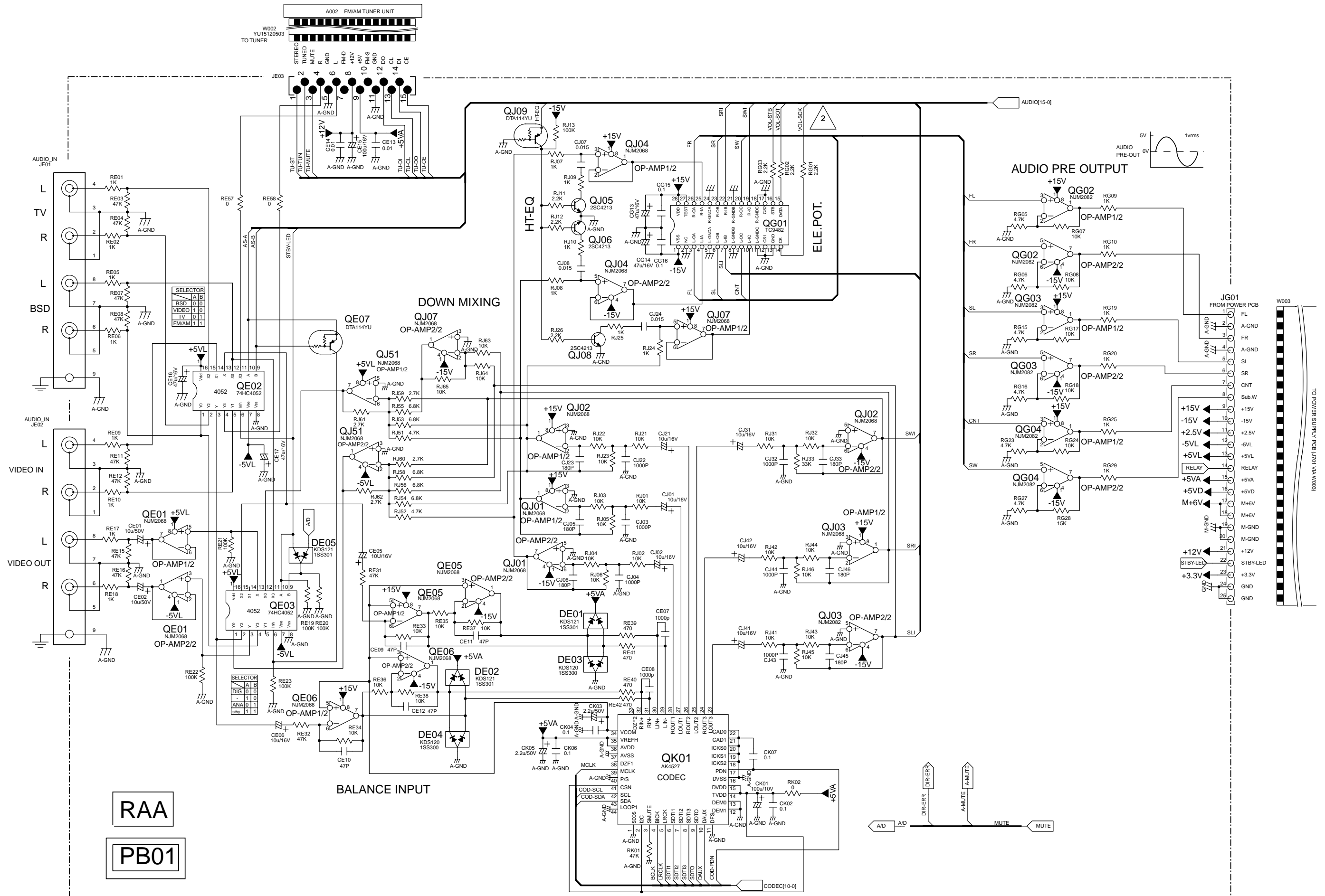

RAA
PB01

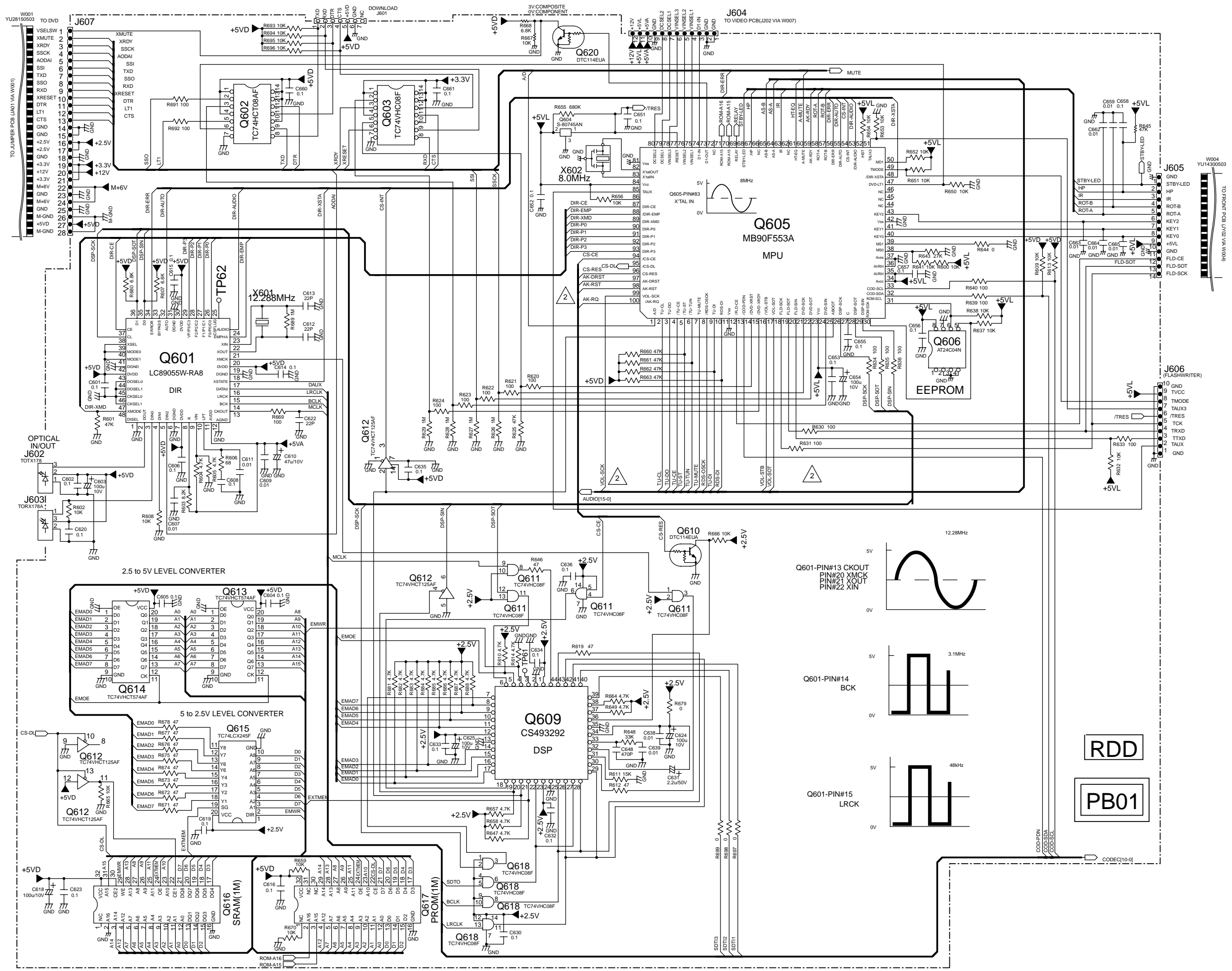

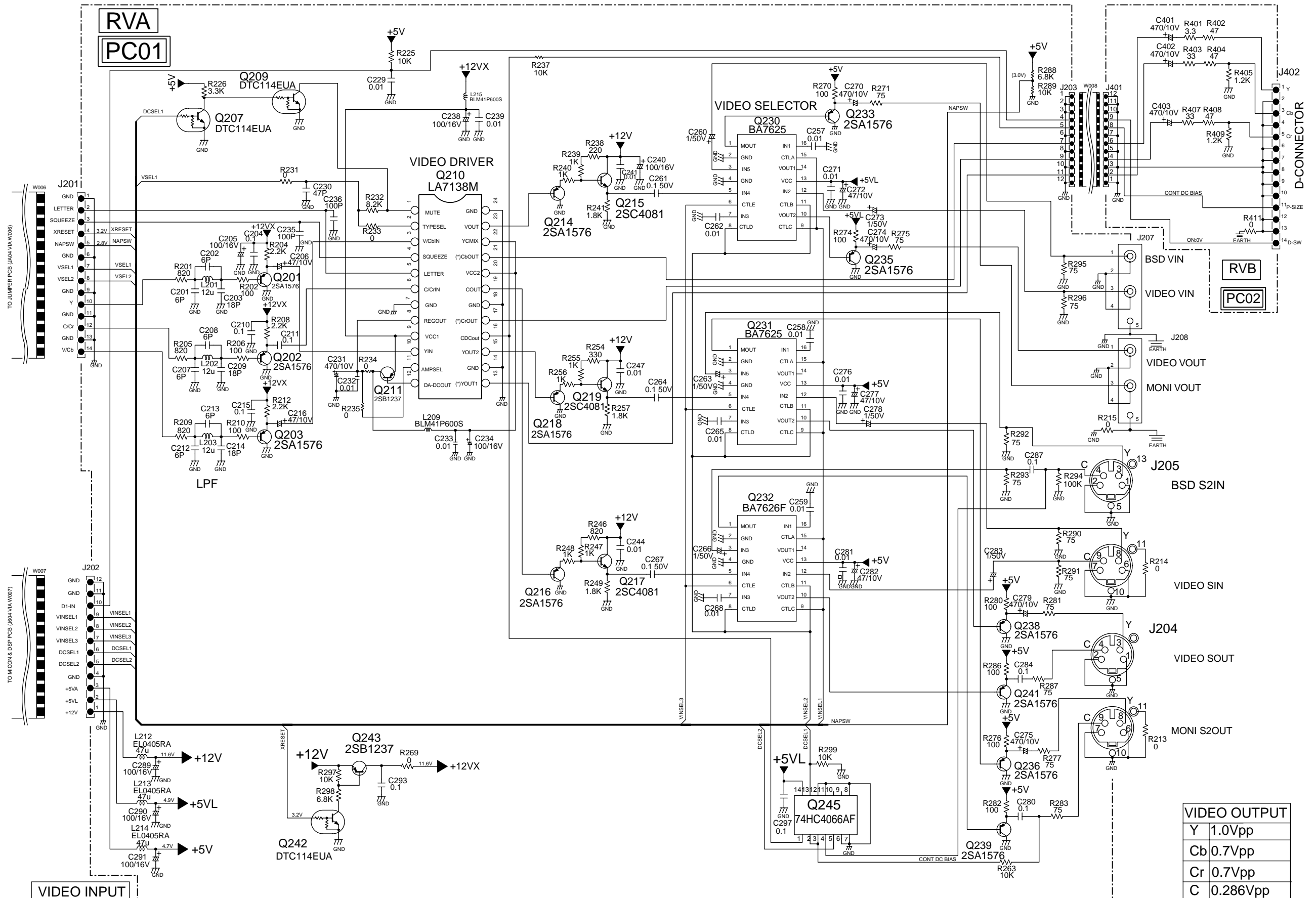

VIDEO INPUT	
Y	0.789Vpp
Cr	0.922Vpp
Cb	0.922Vpp
V	0.789Vpp
C	0.255Vpp

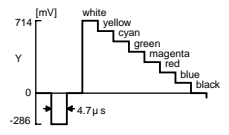

CONT DC BIAS	
4:3	0V
LETTER BOX	2.3V
16:9	5V

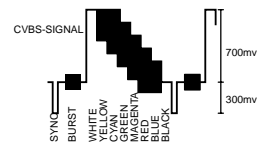

VIDEO OUTPUT	
Y	1.0Vpp
Cb	0.7Vpp
Cr	0.7Vpp
C	0.286Vpp

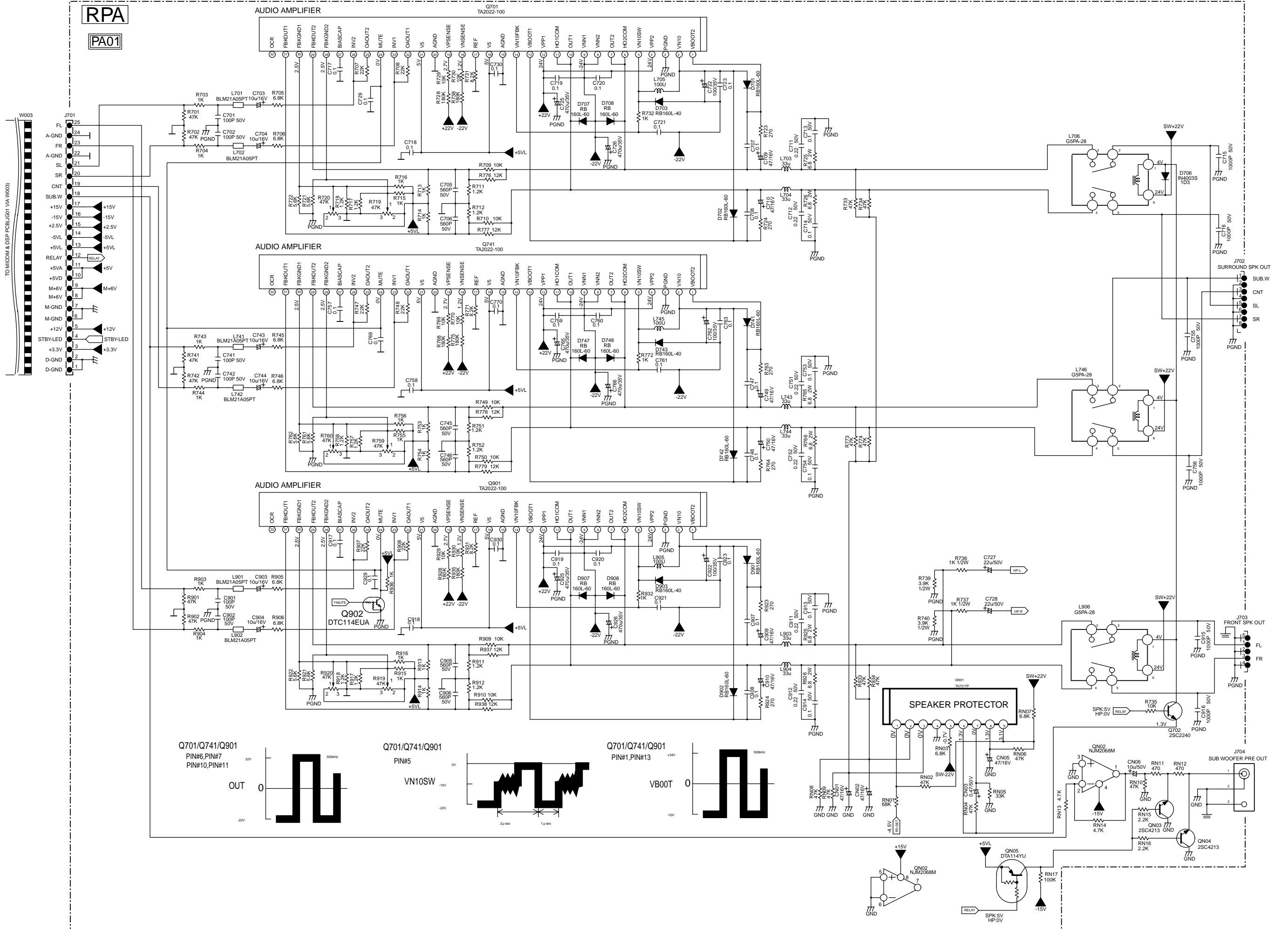

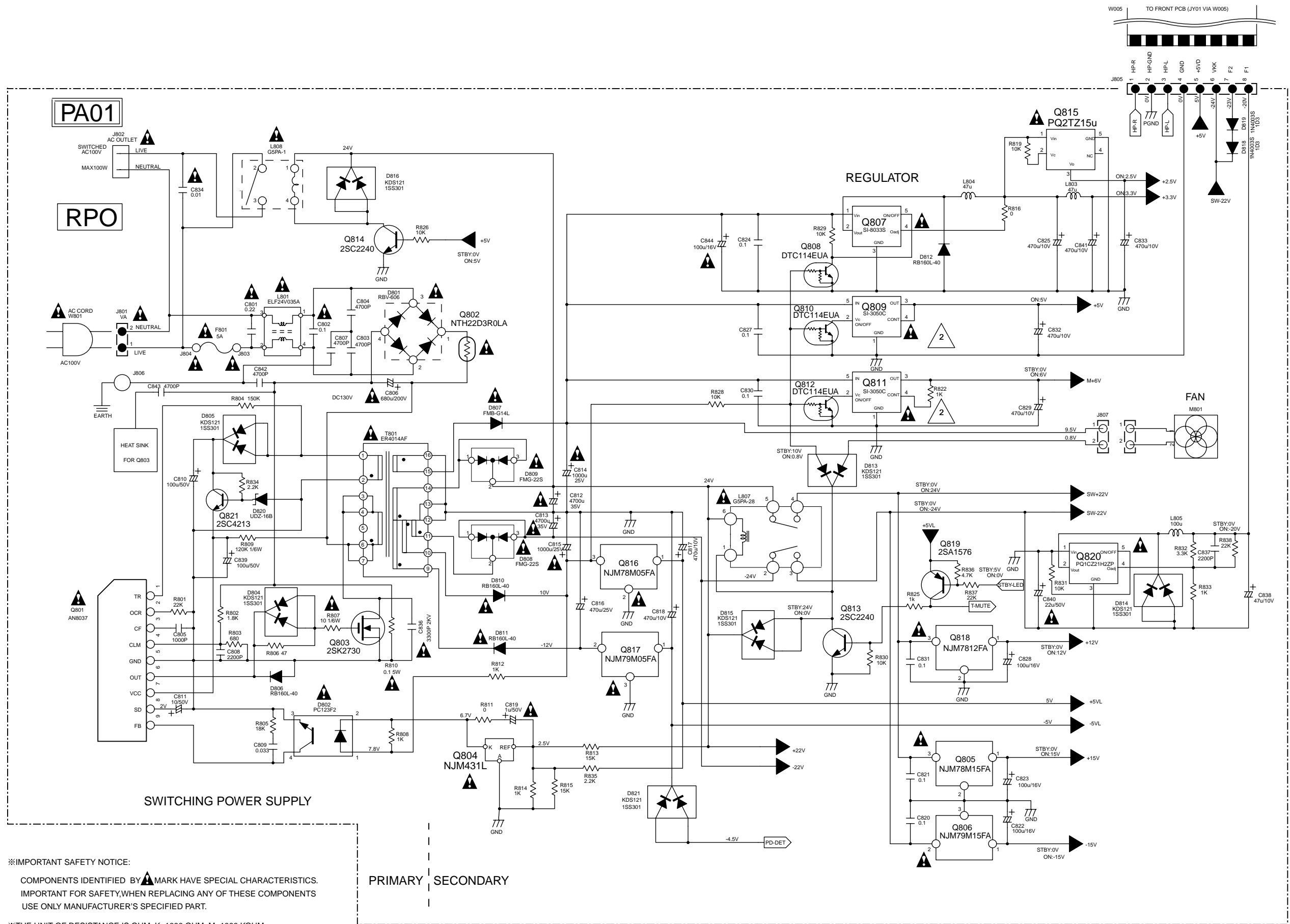

※IMPORTANT SAFETY NOTICE:
 COMPONENTS IDENTIFIED BY MARK HAVE SPECIAL CHARACTERISTICS.
 IMPORTANT FOR SAFETY,WHEN REPLACING ANY OF THESE COMPONENTS
 USE ONLY MANUFACTURER'S SPECIFIED PART.

※THE UNIT OF RESISTANCE IS OHM, K=1000 OHM, M=1000 KOHM.

※THE CAPACITANCE IS MICROFARAD P=PICO FARAD.

※THIS SCHEMATIC DIAGRAM MAY BE MODIFIED AT ANY TIME WITH THE
 IMPROVEMENT OF PERFORMANCE.

※ALL VOLTAGE ARE MEASURED WITH GROUND.

DC:VALUES WITH NO SIGNAL
 AC:RMS

PRIMARY SECONDARY

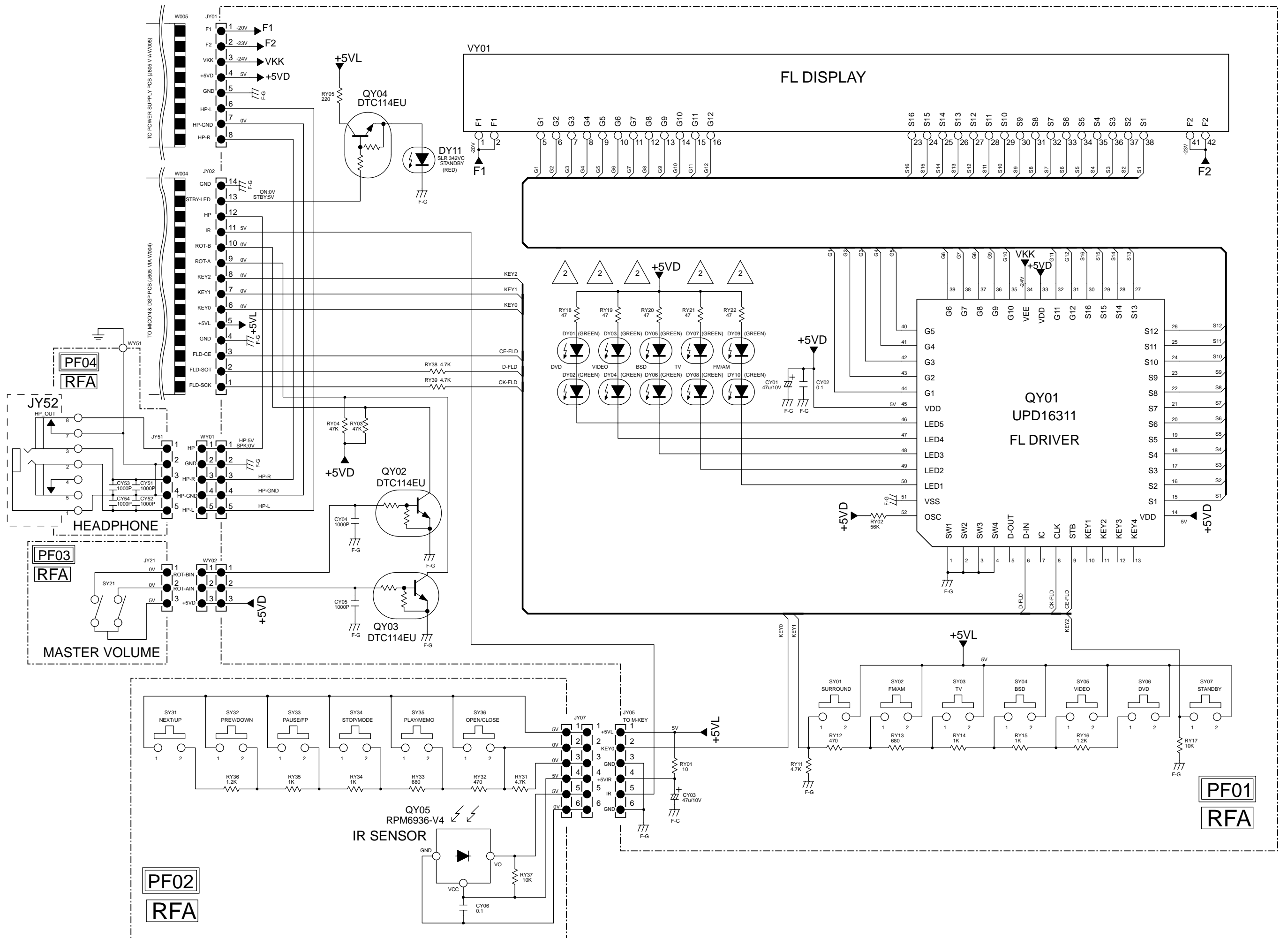

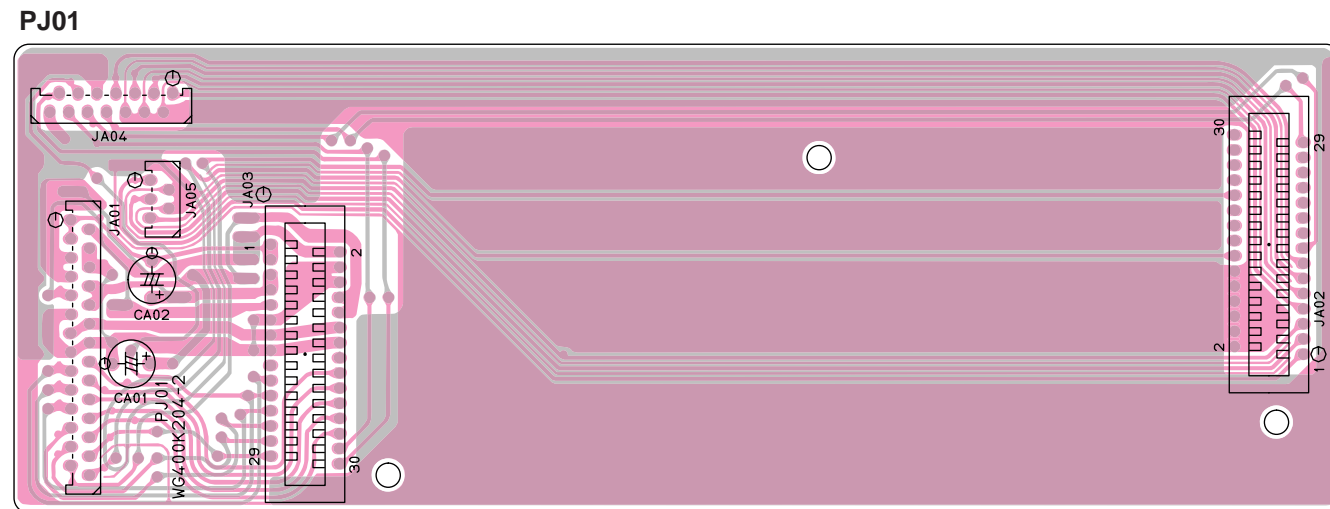
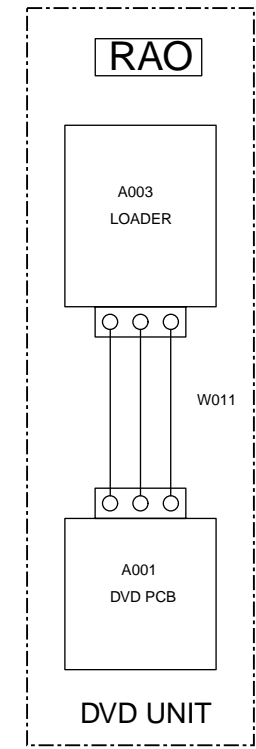
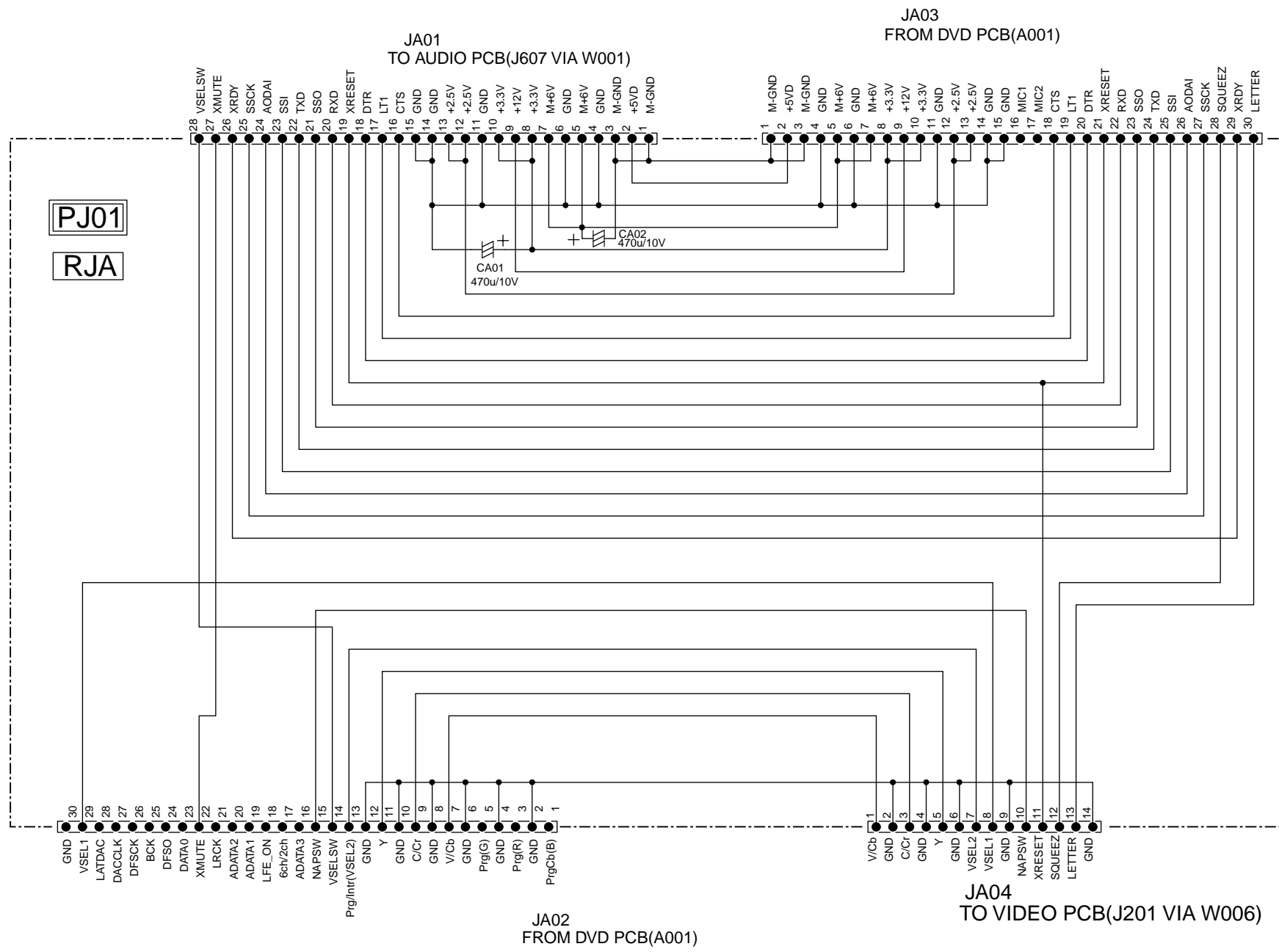

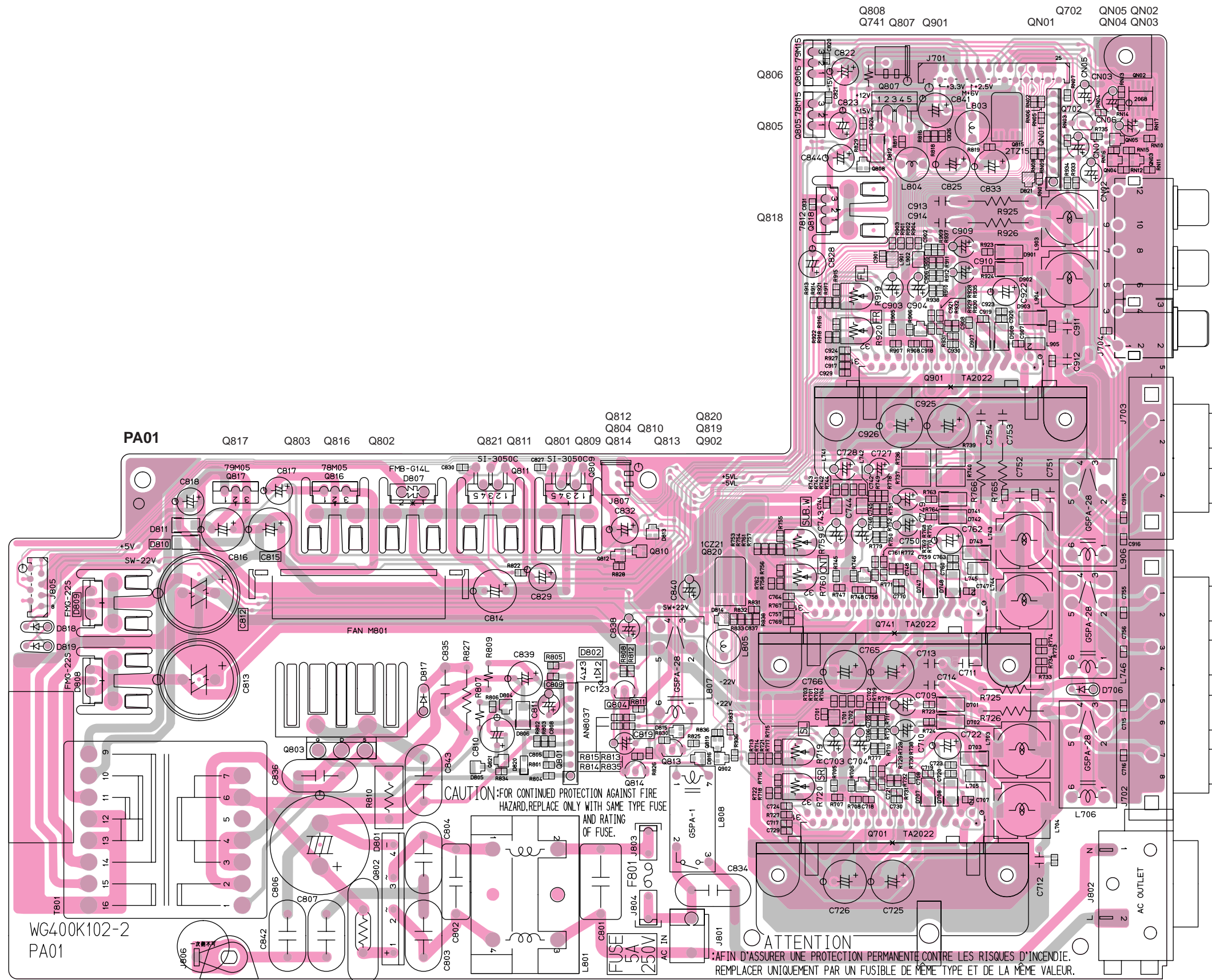

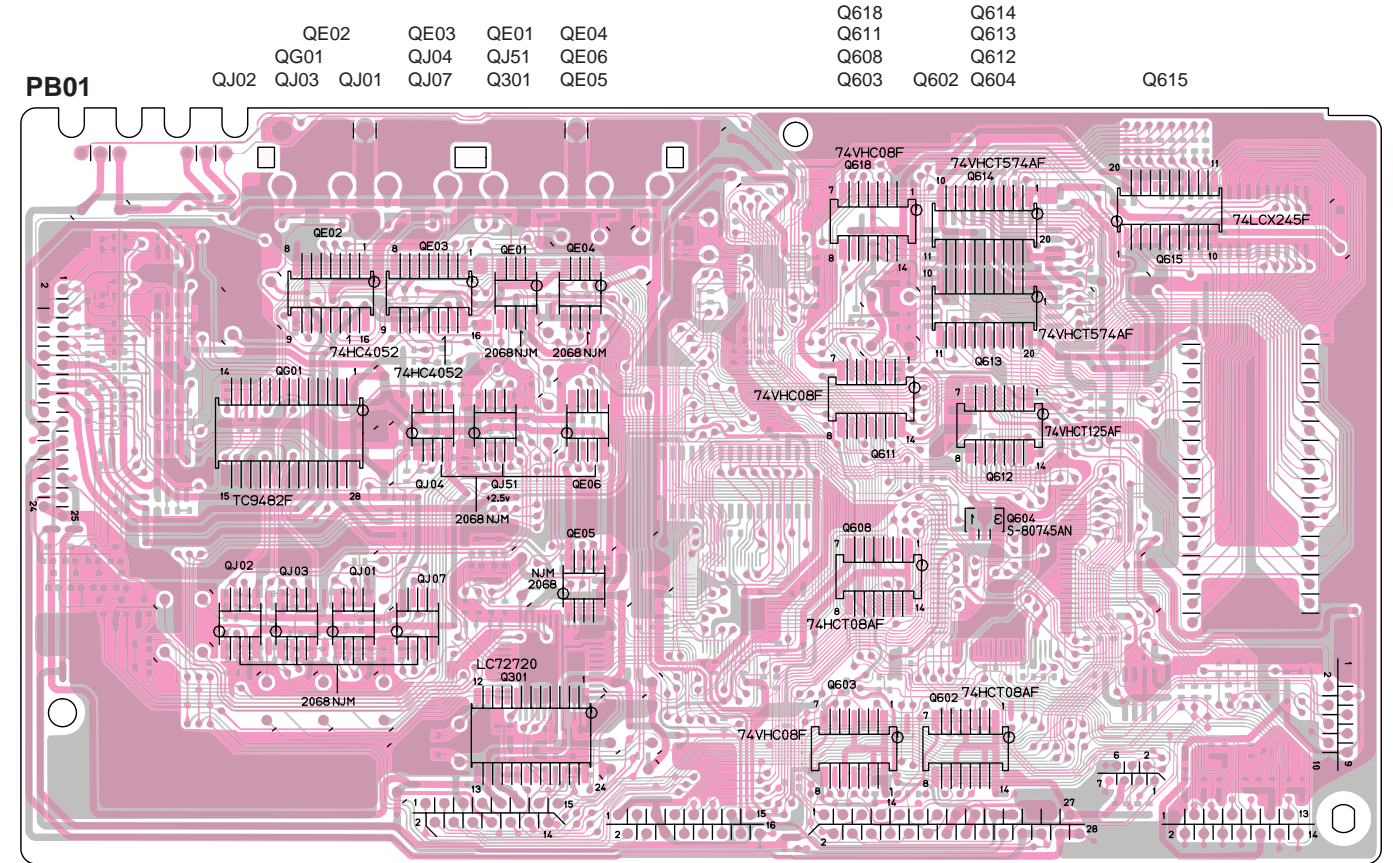
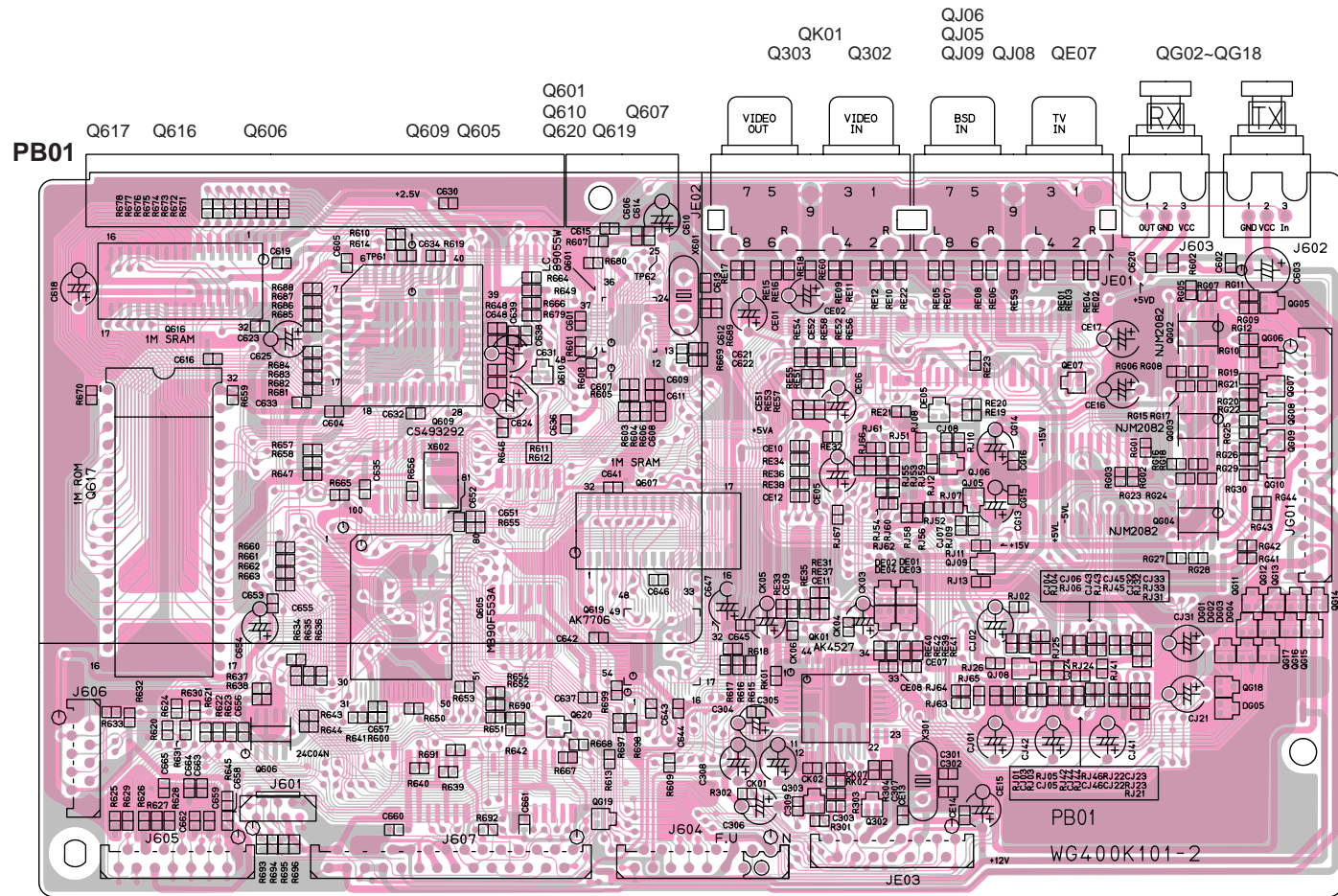

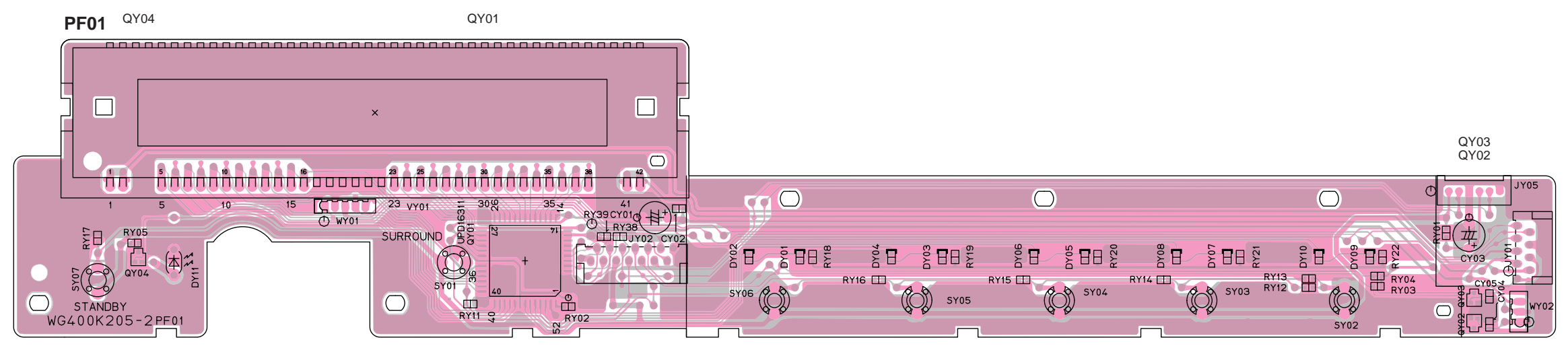
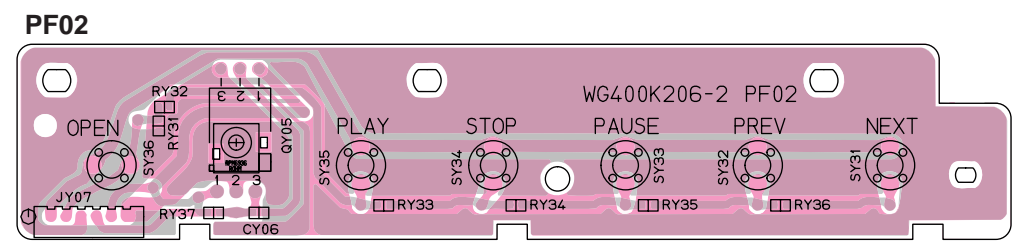
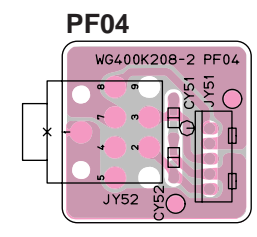
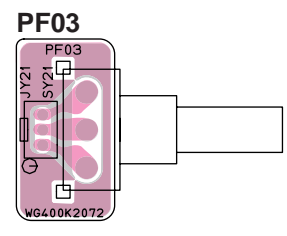
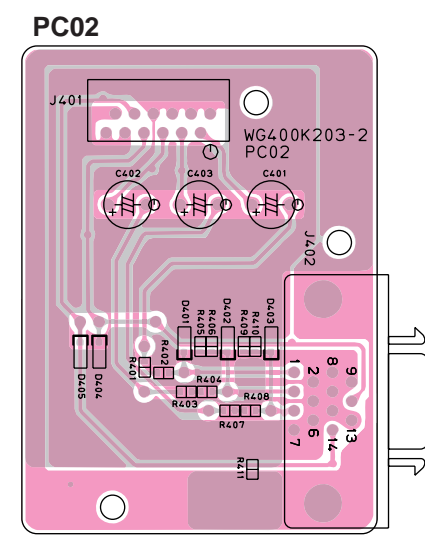
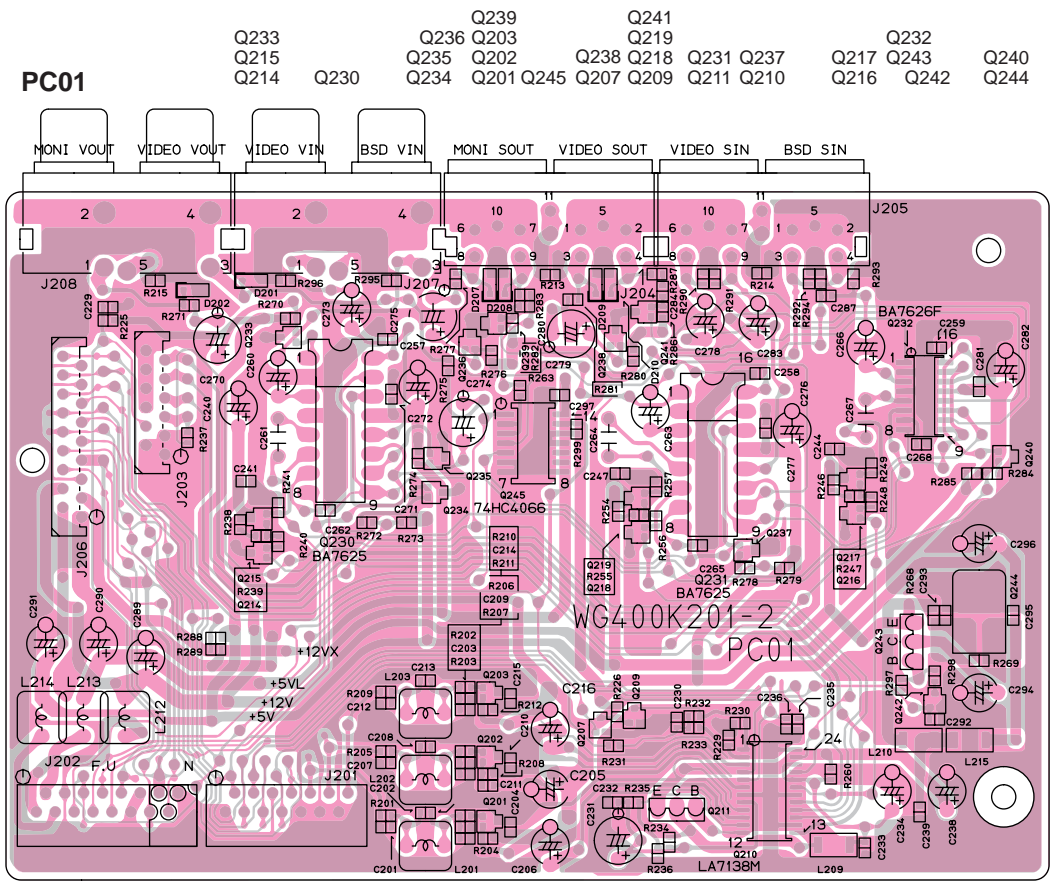

1.5 MICROPROCESSOR AND IC DATA

Q605 :MB90F553A

BLOCK DIAGRAM

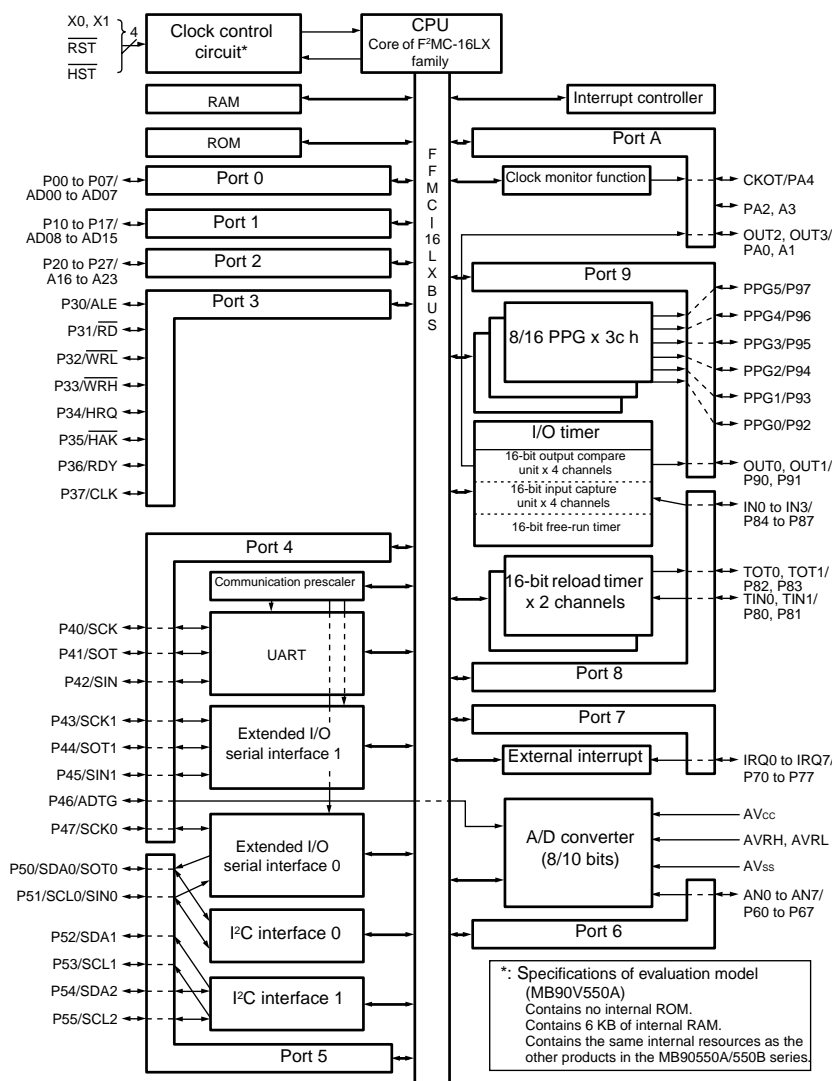

PIN CONFIGURATION

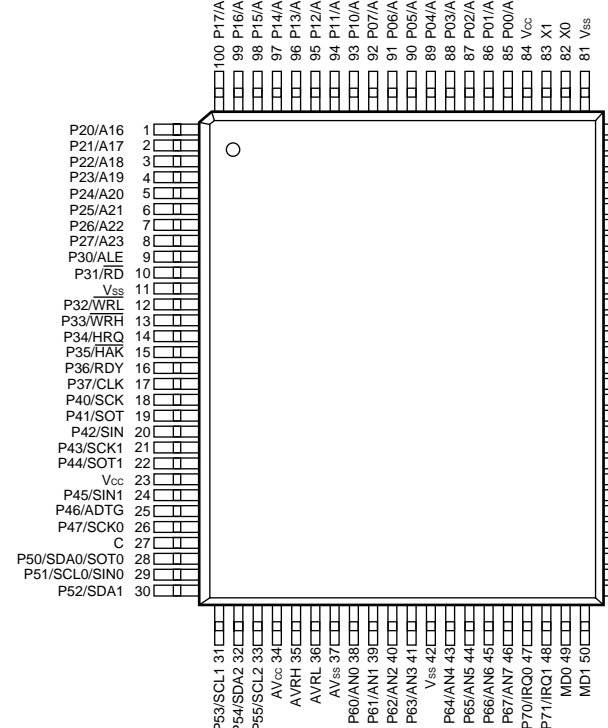

PIN FUNCTION

Pin No.	Port Name	I/O	Name	Active	機能	主な接続先のデバイス
1	P20/A16	O	A/D	H(Analog)	ADC入力時:H、DIR入力時:L	
2	P21/A17	O	TU-CL	-	CCB BUS CLK(PLL,RDS DECODER)	Tuner Pack (PLL:LC72131),RDS:LC72720
3	P22/A18	O	TU-DO	-	CCB BUS DO(PLL,RDS DECODER)	Tuner Pack (PLL:LC72131),RDS:LC72720
4	P23/A19	O	TU-CE	L	CCB BUS CE(PLL,RDS DECODER)	Tuner Pack (PLL:LC72131),RDS:LC72720
5	P24/A20	I	TU-ST	L	TUNER用STEREO信号入力	Tuner Pack (LC1837M)
6	P25/A21	I	TU-TUN	L	Station Detecte信号入力	Tuner Pack (LC1837M)
7	P26/A22	O	TU-MUTE	H	TUNER用IF MUTE出力	Tuner Pack (LC1837M)
8	P27/A23	O	RDS-OSCK	L	RDS用Xtal OSC KILL信号出力(LowでKill)	RDS:LC72720
9	P30/ALE	I	TU-DI	-	CCB BUS DI(PLL DECODER)	Tuner Pack (PLL:LC72131)
10	P31/RD	I	RDS-DI	-	RDS用DATA入力	RDS:LC72720
11	Vss	I	Vss	-	GND	
12	P32/WRL	O	FLD-CE	L	FL Driver用CE出力(立ち下がりで L a c h)	FL Driver:UPD16311
13	P33/WRH	O	COD-PDN	L	CODEC用RESET出力	CODEC:AK4527
14	P34/HRQ	O	DVD-XRST	L	DVD用RESET出力	DVD UNIT:DV535
15	P35/HAK	O	DVD-XRDY	L	DVD用XREADY出力	DVD UNIT:DV535
16	P36/RDY	O	VOL-STB	L	VOLUME用STORE出力(立ち下がりでLach)	System E_Volume:TC9482
17	P37/CLK	O	VOL-SOT	-	VOLUME用DATA出力	System E_Volume:TC9482
18	P40/SCK	O	FLD-SCK	-	FL Driver用CLK出力	FL Driver:UPD16311, Flash ROM Writer
19	P41/SOT	O	FLD-SOT	-	FL Driver用DATA出力	FL Driver:UPD16311, Flash ROM Writer
20	P42/SIN	I	FLD-SIN	-	Flash ROM Writer用DATA入力	Flash ROM Writer
21	P43/SCK1	O	DVD-SCK	-	DVD用CLK出力	DVD UNIT:DV535
22	P44/SOT1	O	DVD-SOT	-	DVD用DATA出力	DVD UNIT:DV535
23	Vcc	I	Vcc	-	+5V	
24	P45/SIN1	I	DVD-SIN	-	DVD用DATA入力	DVD UNIT:DV535
25	P46/ADTG	O	ABOOT	L(OD)	CS49329用AUTO BOOTトリガー信号	DSP:CS49329
26	P47/SCK0	O	DSP-SCK	-	DSP,DIR用CLK出力	DSP:CS49329,AK7706,DIR:LC89055
27	C	-	C	-		
28	P50/SDA0/SOT0	O	DSP-SOT	-	DSP,DIR用DATA出力	DSP:CS49329,AK7706,DIR:LC89055
29	P51/SCL0/SINO	I	DSP-SIN	-	DSP,DIR用DATA入力	DSP:CS49329,AK7706,DIR:LC89055
30	P52/SDA1	I/O	ROM-SDA	-	EE-PROM用DATA入出力	EEPROM:AT24C04N
31	P53/SCL1	I/O	ROM-SCL	-	EE-PROM用CLK出力	EEPROM:AT24C04N
32	P54/SDA2	I/O	COD-SDA	-	CODEC用DATA入出力	CODEC:AK4527
33	P55/SCL2	O	COD-SCL	-	CODEC用CLK出力	CODEC:AK4527
34	Avcc	I	Avcc	-	+5V	
35	AVRH	I	AVRH	-	+5V	
36	AVRL	I	AVRL	-	GND	
37	Avss	I	Avss	-	GND	
38	P60/AN0	I	MS0	-	機種設定用電圧入力	
39	P61/AN1	I	MS1	-	仕向け設定用電圧入力	
40	P62/AN2	I	KEY0	-	8分割 A/D KEY入力0	
41	P63/AN3	I	KEY1	-	8分割 A/D KEY入力1	
42	Vss	I	Vss	-	GND	
43	P64/AN4	I	KEY2	-	STANDBY KEY入力	通常 : プルダウンKEY押下時+5V
44	P65/AN5	NC	NC	-		
45	P66/AN6	NC	NC	-		
46	P67/AN7	NC	NC	-		
47	P70/IRQ0	I	DVD-LT1	H	DVD用LT1信号入力	DVD UNIT:DV535
48	P71/IRQ1	I	DIR-XSTA	L	DIR用XSTATE信号入力	DIR:LC89055
49	MD0	I	TMODE	-	動作モード設定	
50	MD1	I	MD1	-	動作モード設定	
51	MD2	I	TAUX3	-	動作モード設定	
52	HST	I	HST	L	HST	
53	P72/IRQ2	I	DIR-AUDIO	L(PCM)	DIR用AUDIO信号入力	DIR:LC89055
54	P73/IRQ3	I	CS-INT	L	CS49329用割り込み要求入力	DSP:CS49300
55	P74/IRQ4	I	DIR-AUTO	H	DIR用AUTO信号入力	DIR:LC89055
56	P75/IRQ5	I	DIR-ERR	H	DIR用ERROR信号入力	DIR:LC89055
57	P76/IRQ6	I	ROT-B	-	ROTALY ENCODER B 信号入力	Encoder:EC16B24304
58	P77/IRQ7	I	ROT-A	-	ROTALY ENCODER A 信号入力	Encoder:EC16B24304
59	P80/TIN0	I	AK-RDY	H	AK7706用RDY信号入力	DSP:AK7706
60	P81/TIN1	O	A-MUTE	H	ANALOG回路用MUTE信号出力	
61	P82/TOT0	O	HT-EQ	H	HT-EQがONの時にHigh	
62	P83/TOT1	NC	NC	-		
63	P84/INO	I	IR	-	IR Receiver 信号入力	
64	P85/IN1	O	AS-A	-	AUDIO SELECT A信号出力	Selector:74HC4052
65	P86/IN2	O	AS-B	-	AUDIO SELECT B信号出力	Selector:74HC4052
66	P87/IN3	NC	NC	-		
67	P90/OUT0	I	HP	L	ヘッドフォンSENS信号入力	
68	P91/OUT1	O	STBY-LED	H	STANBY-LED点灯信号	
69	P92/PPG0	O	RELAY	H	RELAY制御信号	
70	P93/PPG1	O	ROM-A15	-	DL用ROMアドレス制御信号	ROM
71	P94/PPG2	O	ROM-A16	-	DL用ROMアドレス制御信号	ROM
72	P95/PPG3	NC	NC	-		
73	P96/PPG4	O	D1-OUT	H	D1、Composit出力選択信号出力	DVD UNIT:DV535
74	P97/PPG5	I	D1-IN	L	D1 Connect 検出信号入力	D1 Connector
75	PA0/OUT2	O	VINSEL1	-	Video Selector制御信号出力 1	Video Selector:BA7625,BA7626
76	PA1/OUT3	O	VINSEL2	-	Video Selector制御信号出力 2	Video Selector:BA7625,BA7626
77	RST	I	RESET	L	RESET入力	
78	PA2	O	VINSEL3	-	Video Selector制御信号出力 3	Video Selector:BA7625,BA7626
79	PA3	O	DCSEL1	-	DC Selector制御信号出力 1	DC Selector:74HC4066
80	PA4/CKOT	O	DCSEL2	-	DC Selector制御信号出力 2	DC Selector:74HC4066
81	Vss	I	Vss	-	GND	
82	XO	O	Xtal OUT	-	Xtal発振器出力	
83	XI	I	Xtal IN	-	Xtal発振器入力	
84	Vcc	I	Vcc	-	+5V	
85	P00/AD00	I	TAUX	-		Rom Writer
86	P01/AD01	I	PU	-		
87	P02/AD02	O	DIR-CE	L	DIR用CE信号出力	DIR:LC89055
88	P03/AD03	I	DIR-EMP	H	DIR用EMPHASIS信号入力	DIR:LC89055
89	P04/AD04	O	DIR-XMD	L	DIR用XMODE信号出力	DIR:LC89055
90	P05/AD05	I	DIR-P0	H	DIR用P0信号入力	DIR:LC89055
91	P06/AD06	I	DIR-P1	H	DIR用P1信号入力	DIR:LC89055
92	P07/AD07	I	DIR-P2	H	DIR用P2信号入力	DIR:LC89055
93	P10/AD08	I	DIR-P3	H	DIR用P3信号入力	DIR:LC89055
94	P11/AD09	O	CS-CE	L	CS49329用 Chip Enable信号出力	DSP:CS49329
95	P12/AD10	O	CS-DL	L	CS49329用 DOWNLoad信号出力	DSP:CS49329
96	P13/AD11	O	CS-RES	H	CS49329用 RESET信号出力	DSP:CS49329
97	P14/AD12	O	AK-DRST	L	AK7706用DSP_RESET信号出力	DSP:AK7706
98	P15/AD13	O	AK-RST	L	AK7706用INIT_RESET信号出力	DSP:AK7706
99	P16/AD14	O	VOL-SCK	L	VOLUME用CLK出力	System E_Volume:TC9482
100	P17/AD15	O	AK-RQ	L	AK7706用RQ信号出力	DSP:AK7706

Q601 : LC89055W-RA8

BLOCK DIAGRAM

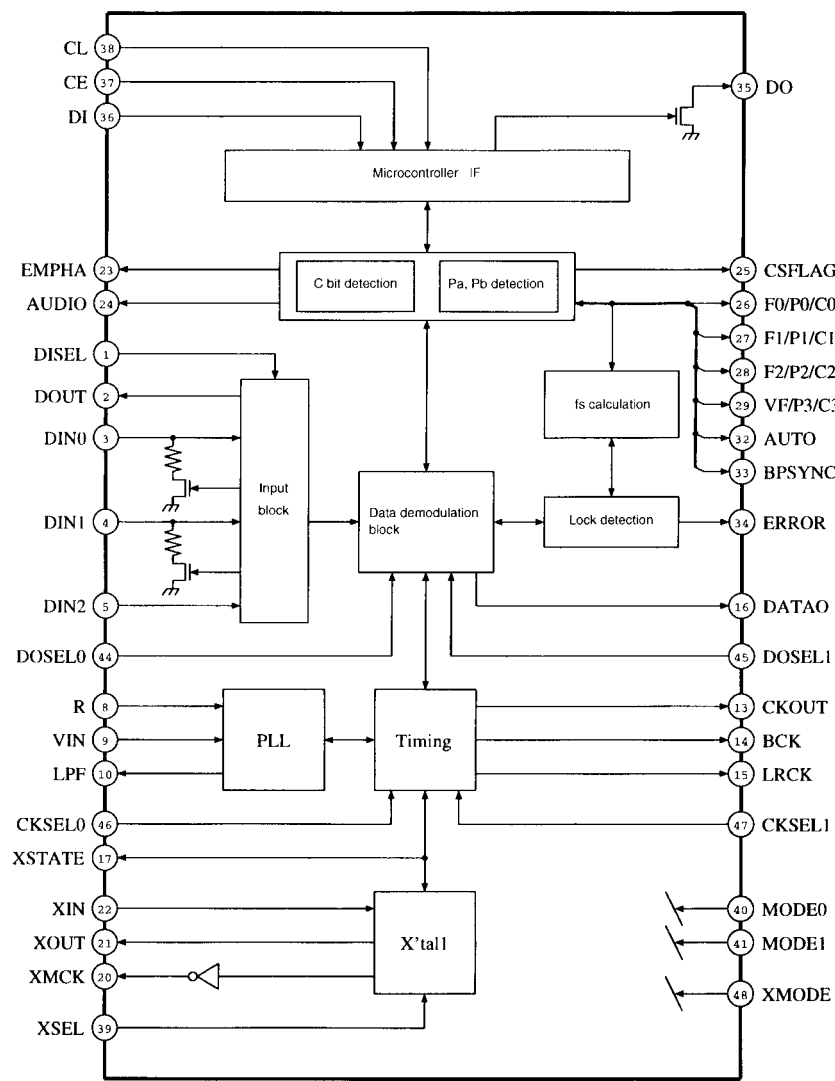

PIN CONFIGURATION

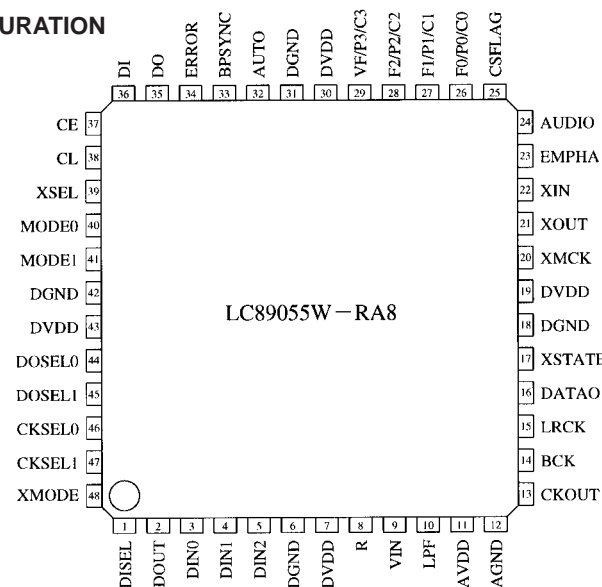

PIN FUNCTION

No.	Pin name	I/O	Function
1	DISEL	I	Data input pin (DIN0, DIN1) selection input pin
2	DOUT	O	Input bi-phase data through output pin
3	DIN0	I	Digital data input pin (CMOS level, with pull-down resistance when no selected)
4	DIN1	I	Digital data input pin (CMOS level, with pull-down resistance when no selected)
5	DIN2	I	Digital data input pin (TTL level)
6	DGND		Digital GND
7	DVDD		Digital power supply
8	R	I	VCO gain control input pin
9	VIN	I	VCO free-running frequency setting input pin
10	LPF	O	PLL loop filter setting pin
11	AVDD		Analog power supply
12	AGND		Analog GND
13	CKOUT	O	Clock output pin (256 fs, 384 fs, 512 fs, crystal oscillation, VCO free-running oscillation)
14	BCK	O	64 fs clock output pin
15	LRCK	O	fs clock output pin (L = R-ch, H = L-ch, I ² S = inverted)
16	DATAO	O	Data output pin
17	XSTATE	O	Source clock switch monitor output pin
18	DGND		Digital GND
19	DVDD		Digital power supply
20	XMCK	O	Crystal oscillation clock output pin (24.576 MHz or 12.288 MHz)
21	XOUT	O	Crystal oscillator connection output pin
22	XIN	I	Crystal oscillator connection input pin, external signal input supported (24.576 MHz or 12.288 MHz)
23	EMPHA	O	Channel status emphasis information output pin
24	AUDIO	O	Channel status bit 1 (non-PCM data detection bit) output pin
25	CSFLAG	O	First 40 channel status bits update flag output pin
26	F0/P0/C0	O	Input fs calculation signal output/Pc data type output/input word length information output pin
27	F1/P1/C1	O	Input fs calculation signal output/Pc data type output/input word length information output pin
28	F2/P2/C2	O	Input fs calculation signal output/Pc data type output/input word length information output pin
29	VF/P3/C3	O	Validity flag output/Pc data type output/input word length information output pin
30	DVDD		Digital GND
31	DGND		Digital power supply
32	AUTO	O	Non-PCM burst data transfer detection signal (Pa, Pb detection) output pin
33	BPSYNC	O	Non-PCM burst preamble Pa, Pb, Pc, Pd sync signal output pin
34	ERROR	O	PLL lock error or data error flag output pin
35	DO	O	Microcontroller IF/read data output pin
36	DI	I	Microcontroller IF/write data input pin
37	CE	I	Microcontroller IF/Chip enable input pin
38	CL	I	Microcontroller IF/clock input pin
39	XSEL	I	[XIN] crystal oscillation selection input pin (24.576 MHz or 12.288 MHz)
40	MODE0	I	Mode setting input pin
41	MODE1	I	Mode setting input pin
42	DGND		Digital GND
43	DVDD		Digital power supply
44	DOSEL0	I	Output data format selection input pin
45	DOSEL1	I	Output data format selection input pin
46	CKSEL0	I	Output clock selection input pin
47	CKSEL1	I	Output clock selection input pin
48	XMODE	I	System reset input pin

Note: * Perform digital power supply (DVDD) and analog power supply (AVDD) ON/OFF with the same potential and the same timing as a latb-up countermeasure.

QK01 : AK4527

BLOCK DIAGRAM

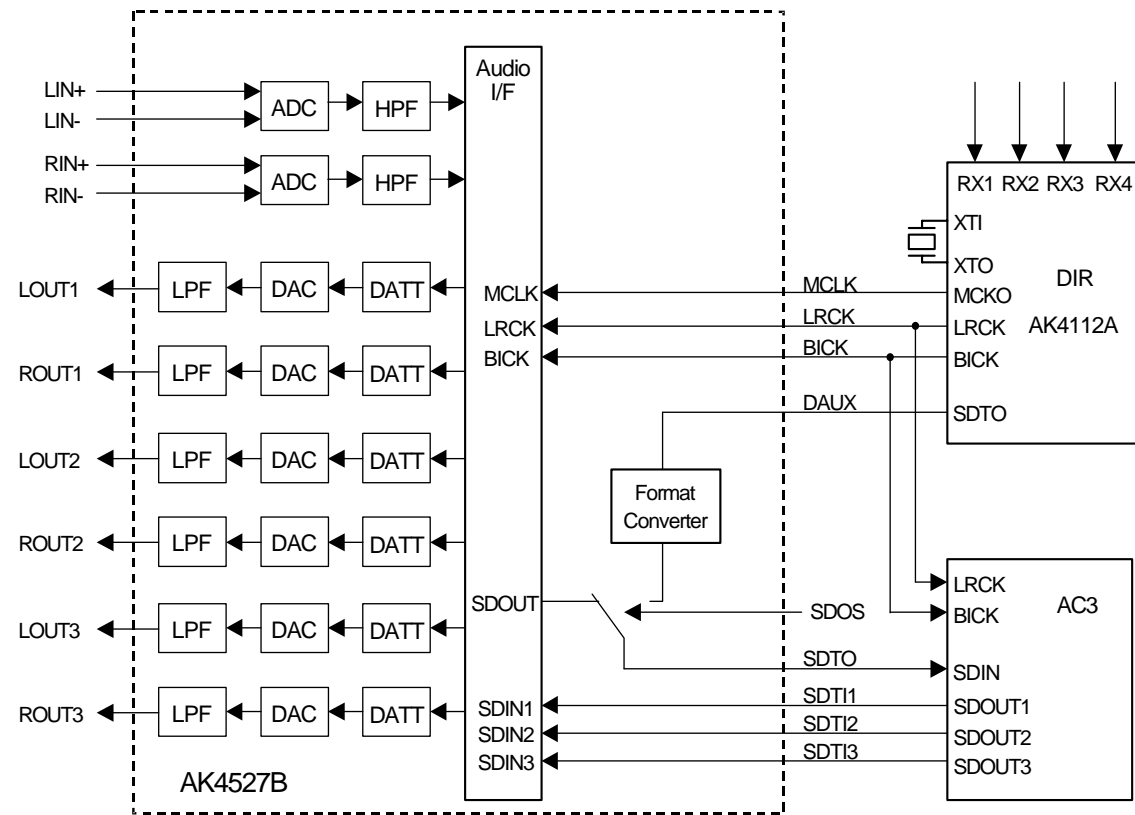

PIN CONFIGURATION

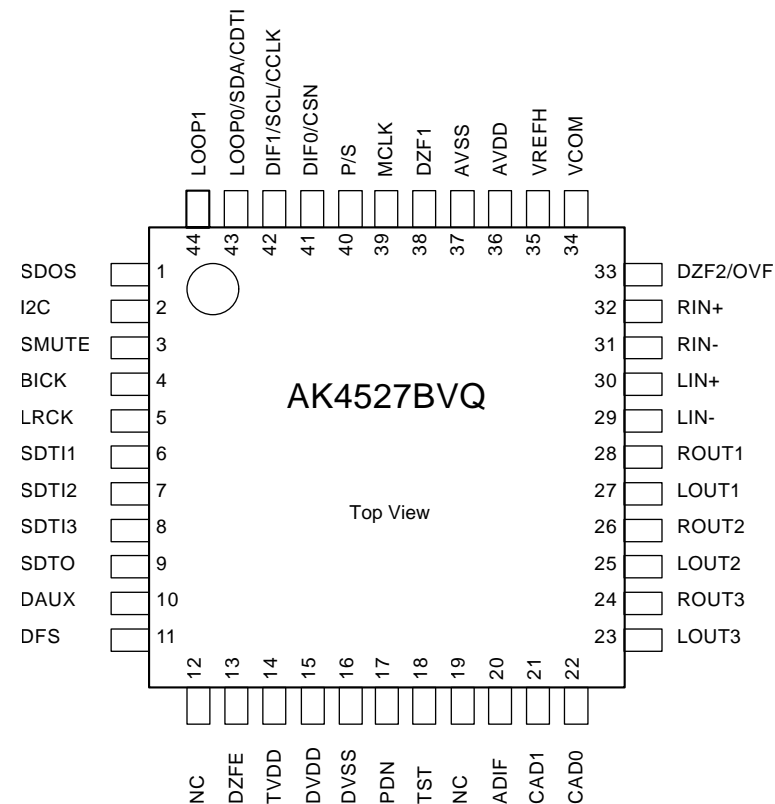

PIN FUNCTION

No.	Pin Name	I/O	Function
1	SDOS	I	SDTO Source Select Pin (Note 1) "L": Internal ADC output, "H": DAUX input
2	I2C	I	Control Mode Select Pin "L": 3-wire Serial, "H": I ² C Bus
3	SMUTE	I	Soft Mute Pin (Note 1) When this pin goes to "H", soft mute cycle is initialized. When returning to "L", the output mute releases.
4	BICK	I	Audio Serial Data Clock Pin
5	LRCK	I	Input Channel Clock Pin
6	SDTI1	I	DAC1 Audio Serial Data Input Pin
7	SDTI2	I	DAC2 Audio Serial Data Input Pin
8	SDTI3	I	DAC3 Audio Serial Data Input Pin
9	SDTO	O	Audio Serial Data Output Pin
10	DAUX	I	AUX Audio Serial Data Input Pin
11	DFS	I	Double Speed Sampling Mode Pin (Note 1) "L": Normal Speed, "H": Double Speed
12	NC	-	No Connect No internal bonding.
13	DZFE	I	Zero Input Detect Enable Pin "L": mode 7 (disable) at parallel mode, zero detect mode is selectable by DZFM2-0 bits at serial mode "H": mode 0 (DZF1 is AND of all six channels)
14	TVDD	-	Output Buffer Power Supply Pin, 2.7V~5.5V
15	DVDD	-	Digital Power Supply Pin, 4.5V~5.5V
16	DVSS	-	Digital Ground Pin, 0V
17	PDN	I	Power-Down & Reset Pin When "L", the AK4527B is powered-down and the control registers are reset to default state. If the state of P/S or CAD0-1 changes, then the AK4527B must be reset by PDN.
18	TST	I	Test Pin This pin should be connected to DVSS.
19	NC	-	No Connect No internal bonding.
20	ADIF	I	Analog Input Format Select Pin "H": Full-differential input, "L": Single-ended input
21	CAD1	I	Chip Address 1 Pin
22	CAD0	I	Chip Address 0 Pin

No.	Pin Name	I/O	Function
23	LOUT3	O	DAC3 Lch Analog Output Pin
24	ROUT3	O	DAC3 Rch Analog Output Pin
25	LOUT2	O	DAC2 Lch Analog Output Pin
26	ROUT2	O	DAC2 Rch Analog Output Pin
27	LOUT1	O	DAC1 Lch Analog Output Pin
28	ROUT1	O	DAC1 Rch Analog Output Pin
29	LIN-	I	Lch Analog Negative Input Pin
30	LIN+	I	Lch Analog Positive Input Pin
31	RIN-	I	Rch Analog Negative Input Pin
32	RIN+	I	Rch Analog Positive Input Pin
33	DZF2	O	Zero Input Detect 2 Pin (Note 2) When the input data of the group 1 follow total 8192 LRCK cycles with "0" input data, this pin goes to "H".
	OVF	O	Analog Input Overflow Detect Pin (Note 3) This pin goes to "H" if the analog input of Lch or Rch is overflows.
34	VCOM	O	Common Voltage Output Pin, AVDD/2 Large external capacitor around 2.2μF is used to reduce power-supply noise.
35	VREFH	I	Positive Voltage Reference Input Pin, AVDD
36	AVDD	-	Analog Power Supply Pin, 4.5V~5.5V
37	AVSS	-	Analog Ground Pin, 0V
38	DZF1	O	Zero Input Detect 1 Pin (Note 2) When the input data of the group 1 follow total 8192 LRCK cycles with "0" input data, this pin goes to "H".
39	MCLK	I	Master Clock Input Pin
40	P/S	I	Parallel/Serial Select Pin "L": Serial control mode, "H": Parallel control mode
41	DIF0	I	Audio Data Interface Format 0 Pin in parallel control mode
	CSN	I	Chip Select Pin in 3-wire serial control mode This pin should be connected to DVDD at I ² C bus control mode
42	DIF1	I	Audio Data Interface Format 1 Pin in parallel control mode
	SCL/CCLK	I	Control Data Clock Pin in serial control mode I2C = "L": CCLK (3-wire Serial), I2C = "H": SCL (I ² C Bus)
43	LOOP0	I	Loopback Mode 0 Pin in parallel control mode Enables digital loop-back from ADC to 3 DACs.
	SDA/CDTI	I/O	Control Data Input Pin in serial control mode I2C = "L": CDTI (3-wire Serial), I2C = "H": SDA (I ² C Bus)
44	LOOP1	I	Loopback Mode 1 Pin (Note 1) Enables all 3 DAC channels to be input from SDTI1.

Notes: 1. SDOS, SMUTE, DFS, and LOOP1 pins are ORed with register data if P/S = "L".
2. The group 1 and 2 can be selected by DZFM2-0 bits if P/S = "L" and DZFE = "L".
3. This pin becomes OVF pin if OVFE bit is set to "1" at serial control mode.
4. All input pins should not be left floating.

Q701 : TA2022-100

BLOCK DIAGRAM

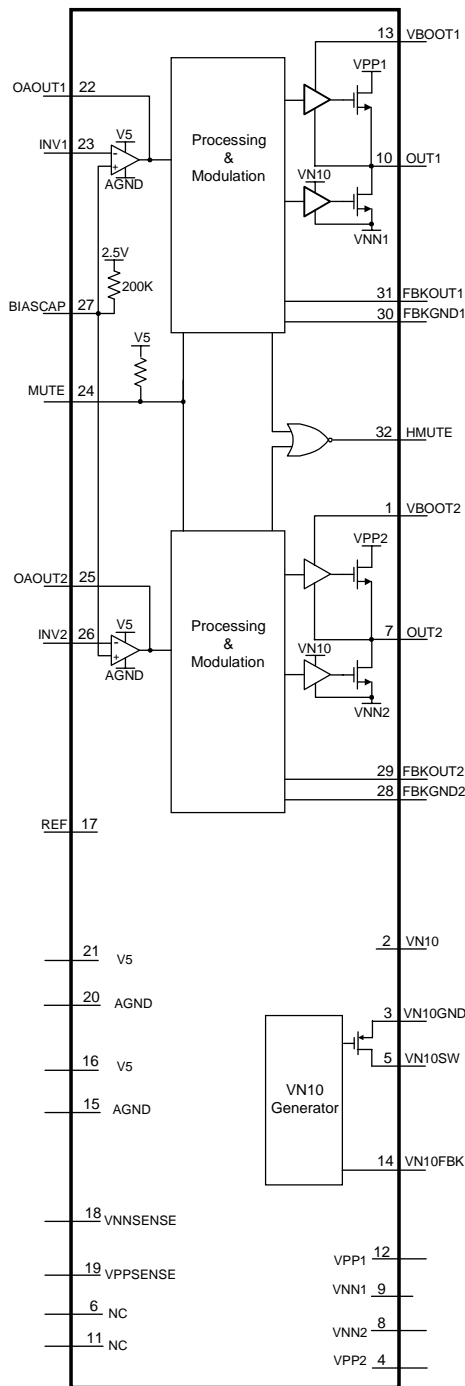

PIN CONFIGURATION

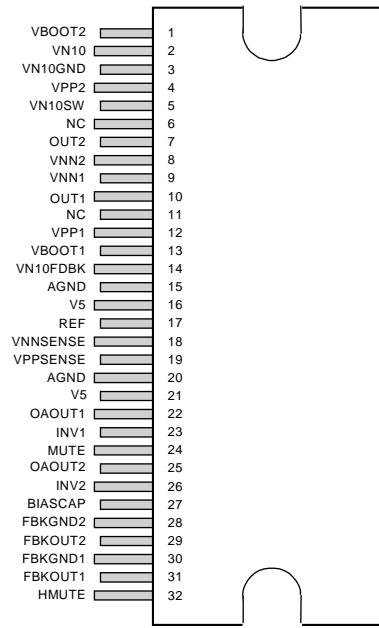

PIN FUNCTION

Pin	Function	Description
1, 13	VBOOT2, VBOOT1	Bootstrap voltages for gate drive of high side MOSFET s
2	VN10	Floating supply input. Normally connected to the output of onboard VN10 buck converter. This voltage must be stable and referenced to VNN.
3	VN10GND	Power ground for onboard VN10 generator. Electrically tied to the TA2022 case.
4, 12	VPP2, VPP1	Positive power supply input pins.
5	VN10SW	Switching output voltage for onboard VN10 generator (buck converter).
6	NC	Not connected internally. May be connected to pin 7 without any loss of functionality or performance.
7, 10	OUT2, OUT1	Power amplifier outputs.
8, 9	VNN2, VNN1	Negative power supply inputs.
11	NC	Not connected internally. May be connected to pin 10 without any loss of functionality or performance.
14	VN10FDBK	Feedback for onboard VN10 generator (nominally 11V above VNN)
15, 20	AGND	Analog Ground.
16, 21	V5	5V power supply input.
17	REF	Used to set internal bias currents. The pin voltage is typically 1.1V.
18	VNNSENSE	Negative supply voltage sense input. This pin is used for both over and under voltage sensing for the VNN supply.
19	VPPSENSE	Positive supply voltage sense input. This pin is used for both over and under voltage sensing for the VPP supply.
22, 25	OAOUT1, OAOUT2	Outputs of Input Stage op amps.
23, 26	INV1, INV2	Inverting inputs of Input Stage op amps.
24	MUTE	Logic input. A logic high puts the amplifier in mute mode. Ground pin if not used. Please refer to the section, Mute Control, in the Application Information.
27	BIASCAP	Bandgap reference times two (typically 2.5VDC). Used to set the common mode voltage for the input op amps. This pin is not capable of driving external circuitry.
28, 29	FBKGND2, FBKOUT2	Output voltage differential feedback for channel 2.
30, 31	FBKGND1, FBKOUT1	Output voltage differential feedback for channel 1.
32	HMUTE	Logic Output. A logic high indicates both amplifiers are muted, due to the mute pin state, or a fault such as an overcurrent, undervoltage, or overvoltage condition.

Q609 : CS493292

BLOCK DIAGRAM

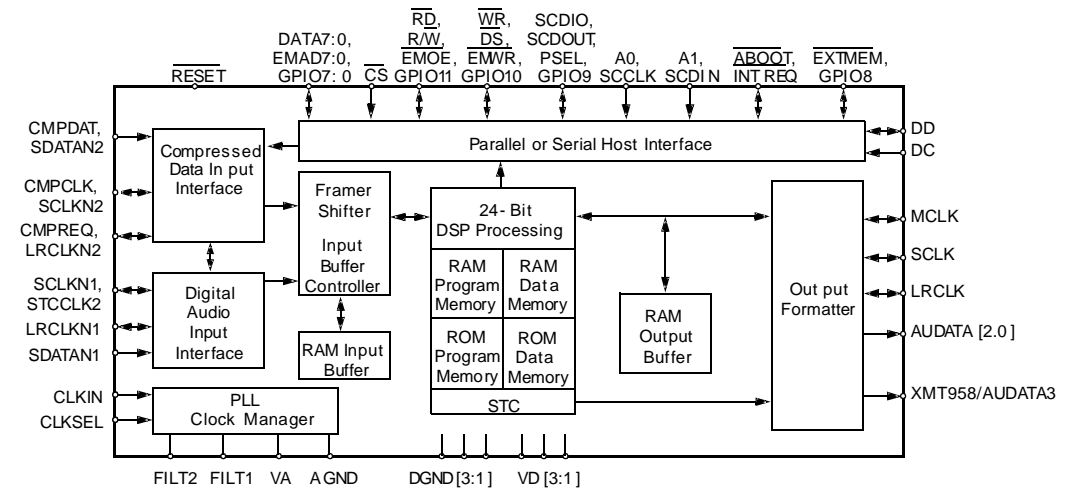

PIN CONFIGURATION

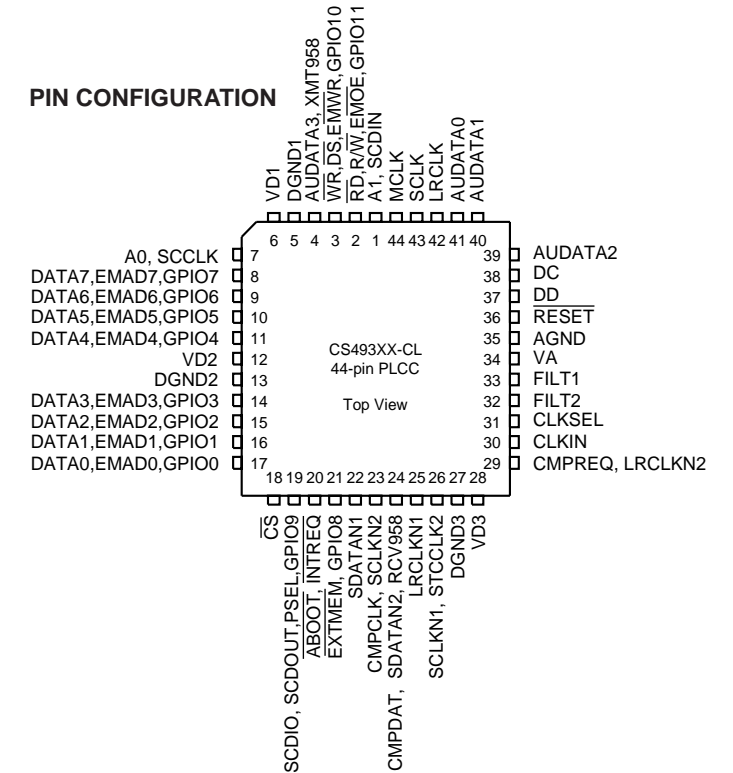

QN01 : TA7317P

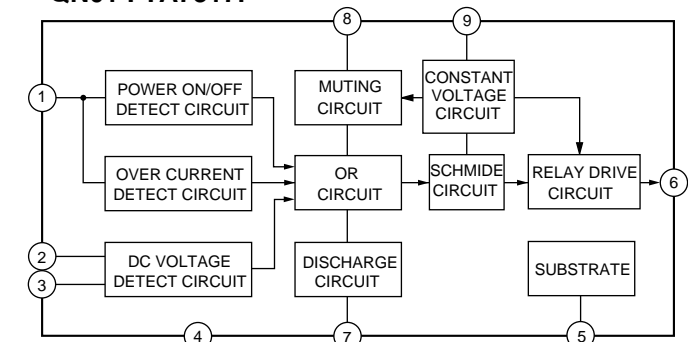

QG01 : TC9482F
BLOCK DIAGRAM

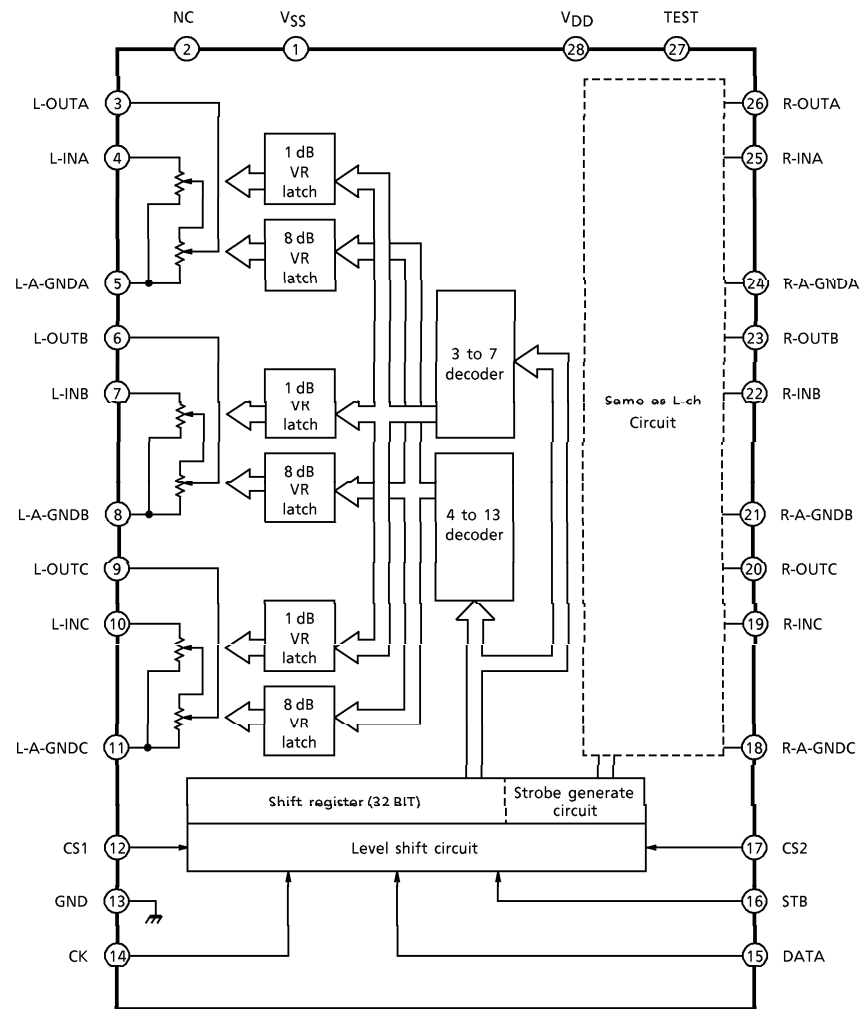

PIN CONFIGURATION

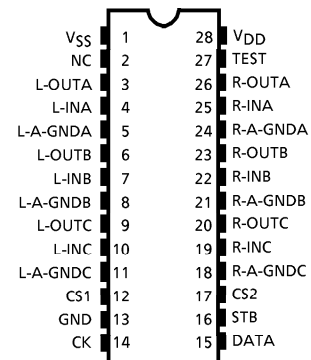

PIN FUNCTION

PIN No.	SYMBOL	PIN NAME	FUNCTION	REMARK
1	VSS	Negative power supply pin	● Power Supply Pins	—
28	VDD	Positive power supply pin		
3	L-OUTA	Volume output pin	● Volume circuit	—
26	R-OUTA			
6	L-OUTB			
22	R-OUTB			
9	L-OUTC			
19	R-OUTC			
4	L-INA	Volume input pin	—	
25	R-INA			
7	L-INB			
22	R-INB			
19	R-OUTC	Analog GND pin	—	
4	L-INA			
25	R-INA			
7	L-INB			
22	R-INB			
19	R-OUTC			
5	L-A-GNDA	Chip select input pin	Up to 4 chips on the same bus can be used by switching over chip select code.	—
24	R-A-GNDA			
8	L-A-GNDB			
21	R-A-GNDB			
11	L-A-GNDC	Low threshold value input pin	—	
18	R-A-GNDC			
12	CS1	Chip select input pin	Up to 4 chips on the same bus can be used by switching over chip select code.	—
17	CS2			
14	CK	Clock input pin	Inputs clock for serial data transfer.	Low threshold value input pin
15	DATA	Data input pin	Inputs control data for setting volume.	
16	STB	Strobe input pin	Inputs strobe for writing data.	—
13	GND	Digital GND pin	Digital ground pin	
27	TEST	Test Pin	Normally connect to VDD pin.	—
2	NC	No connection	—	—

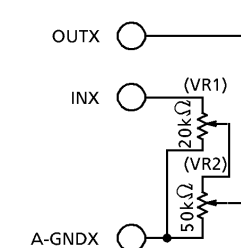

Q606 : AT24C04N
BLOCK DIAGRAM

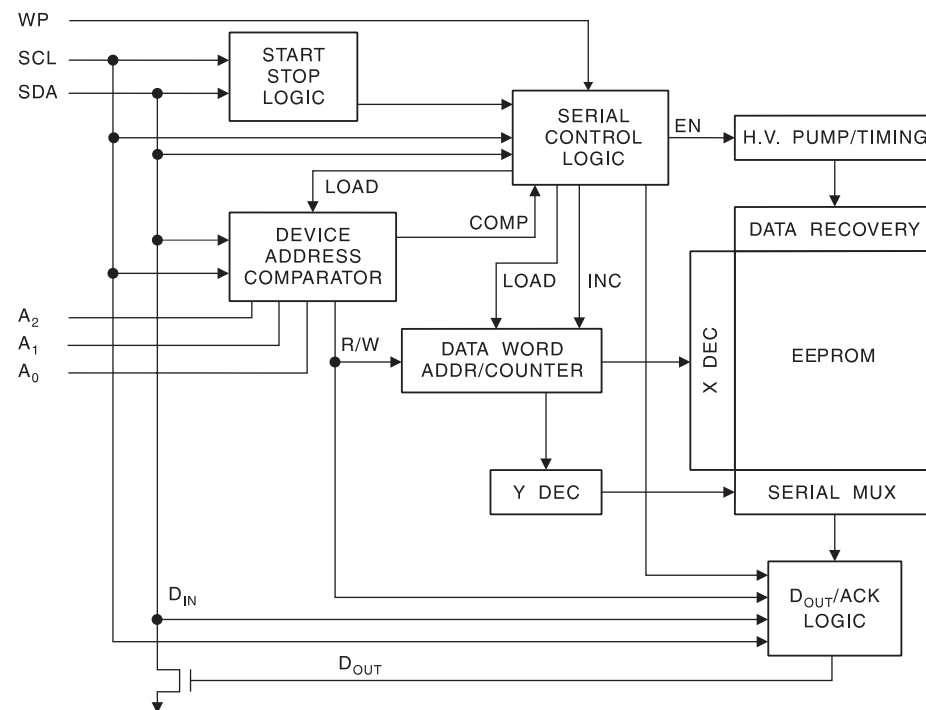

PIN CONFIGURATION

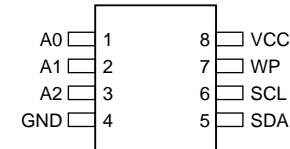

QY01 : μ PD16311GC-AB6

BLOCK DIAGRAM

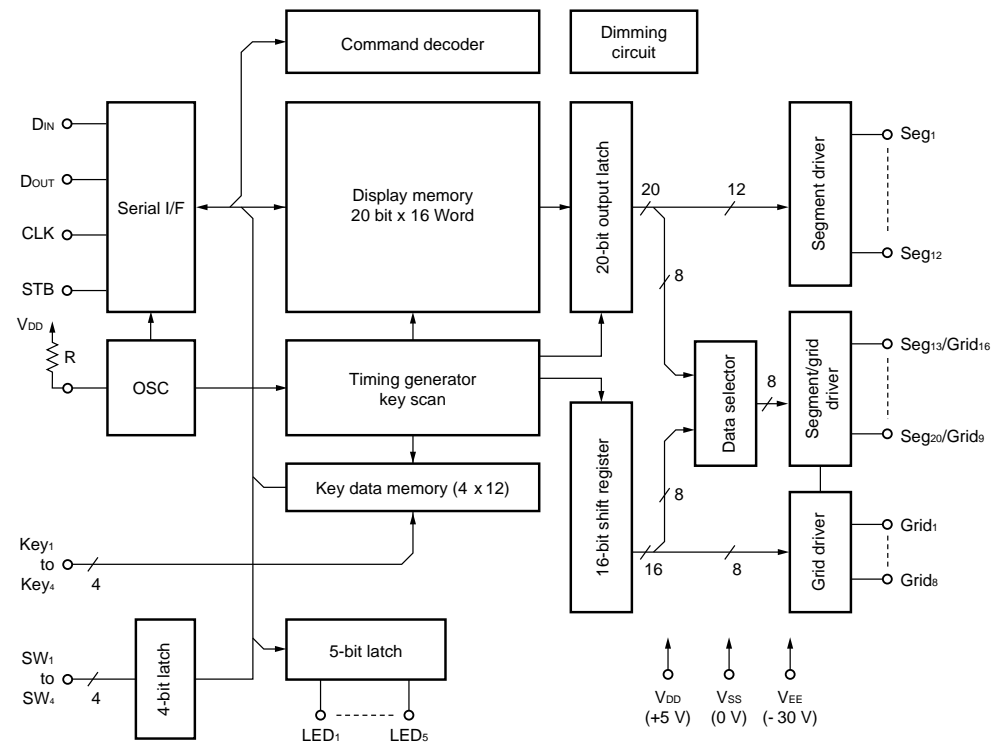

PIN CONFIGURATION

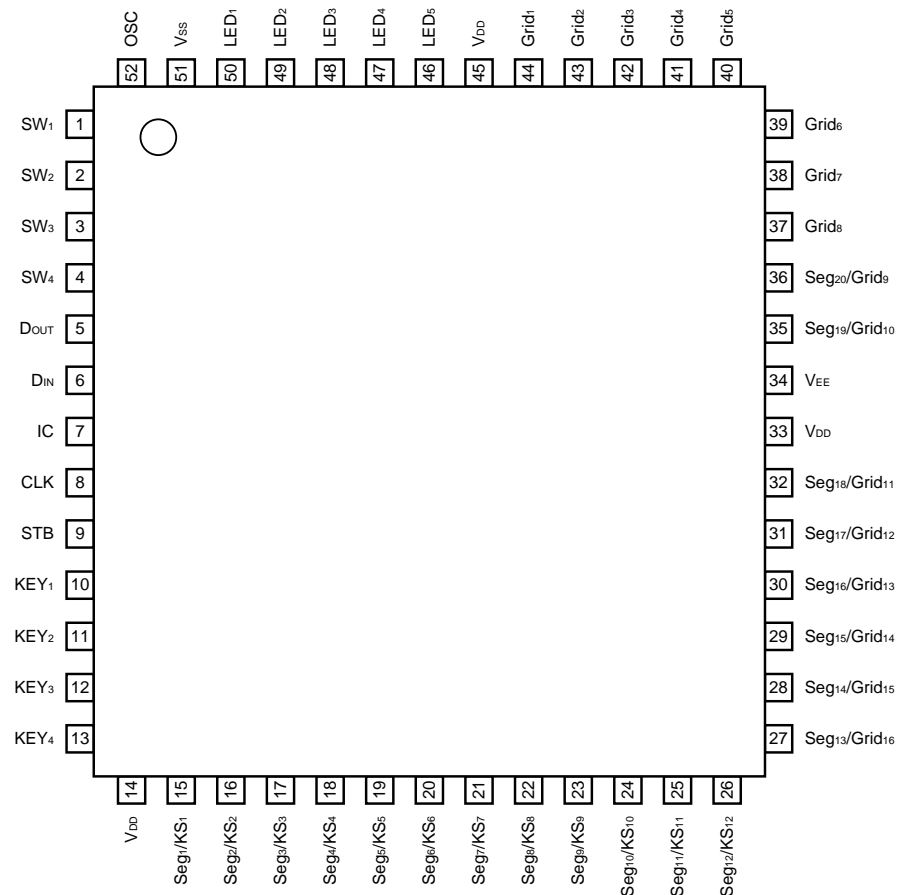

PIN FUNCTION

Pin No.	Symbol	Pin Name	Description
6	D _{IN}	Data input	Inputs serial data at rising edge of shift clock, starting from lower bit.
5	D _{OUT}	Data output	Outputs serial data at falling edge of shift clock, starting from lower bit. This is N-ch open-drain output pin.
9	STB	Strobe	Initializes serial interface at rising or falling edge to make PD16311 waiting for reception of command. Data input after STB has fallen is processed as command. While command data is processed, current processing is stopped, and serial interface is initialized. While STB is high, CLK is ignored.
8	CLK	Clock input	Reads serial data at rising edge, and outputs data at falling edge.
52	OSC	Oscillator pin	Connect resistor for determining oscillation frequency to this pin.
15 to 26	Seg ₁ /KS ₁ to Seg ₁₂ /KS ₁₂	High-voltage output (segment)	Segment output pins (Dual function as key source)
44 to 37	Grid ₁ to Grid ₆	High-voltage output (grid)	Grid output pins
27 to 32 35 to 36	Seg ₁₃ /Grid ₁₆ to Seg ₂₀ /Grid ₉	High-voltage output (segment/grid)	These pins are selectable for segment or grid output.
50 to 46	LED ₁ to LED ₅	LED output	CMOS output. +20 mA max.
10 to 13	Key ₁ to Key ₄	Key data input	Data input to these pins is latched at end of display cycle.
1 to 4	SW ₁ to SW ₄	Switch input	These pins constitute 4-bit general-purpose input port.
14, 33, 45	V _{DD}	Logic power	5 V 10 %
51	V _{SS}	Logic ground	Connect this pin to GND of system.
34	V _{EE}	Pull-down level	V _{DD} 35 V max.
7	IC	Internally connected	Be sure to leave this pin open (this pin is at V _{DD} level).

Q617 : AT27C010

BLOCK DIAGRAM

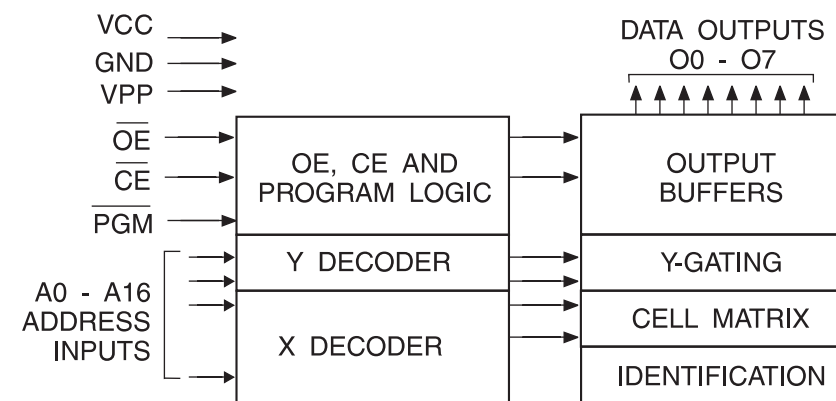

PIN CONFIGURATION

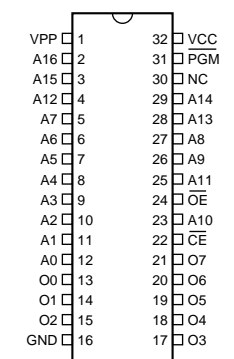

1.6 TECHNICAL DESCRIPTION

CLASS-T DIGITAL AUDIO AMPLIFIER TECHNOLOGY (TRIPATH)

A Watershed in Digital Amplification

Tripath amplifiers use a completely new proprietary method of Digital Power Processing[™] that provides superior performance to conventional methods of amplification. For the first time, both high signal fidelity AND high power efficiency can be achieved with the same technology. Tripath refers to this DPP[™] based amplifier as a Class-T design. The underlying technology of Class-T does not use PWM and is not a pure analog approach (Classes -A and -AB). It combines the benefits of both with a completely new approach.

Tripath's Class-T amplifiers are the first application of this breakthrough approach. Class-T amplifiers provide the signal fidelity of sophisticated discrete-component linear Class-A and -AB designs, while offering high power efficiencies and the potential to need less exotic engineering to achieve high-end audiophile performance. These amplifiers also reduce cost for amplifier overhead at high power levels (such as power supply, filtering, and heat venting). Class-T provides power conversion efficiencies of 80 percent to more than 90 percent, which is equal to or better than Class-D amplifiers.

AACとは

AACとは信号圧縮規格MPEG2のオーディオ部の仕様である「Advanced Audio Coding」の略称。CDの約10分の1の圧縮率を持った次世代オーディオの符号化規格である。128Kb/s程度でCD並の高品質マルチチャンネルステレオが可能である。MPEG1のオーディオとの互換性は無いが、MPEG4にも採用された。現在、BSデジタルテレビ放送に使用されており、5.1ch仕様が可能でマルチサラウンドが実現できるのが特徴です。

ER3000はBSデジタル放送で使用されるMPEG2-AACのオーディオデコード機能を実現しています。デジタル出力を持ったBSデジタル受信機とダイレクトに接続し5.1ch仕様のマルチサラウンドが実現できます。

1.7 ADJUSTMENT PROCEDURE

7. 調整手順書

1. FANの動作確認

POWER ON 状態の時に電源 PCB(PA01)のFAN(M801)が回っている事を確認する。(STANDBY 状態で停止する。)

2. DVDレーザー・ダイオード保護SWの解除

DVD LOADER(A003)の中央部にあるレーザー・ダイオード保護SWをOFFにする。
(ER3000を正面から見てスライドSWのレバー位置を左側にする。)

注意：レーザー光源を直視しない事。

3. スピーカー保護回路の確認とオフセット電圧調整

セットの状態 : POWER ON

測定器 : デジタル・テスター

測定箇所 : 各スピーカー・ターミナル6箇所
RS (Right Surround) , LS (Left Surround) , C (Center) , SW (Sub Woofer)
R (Front Right) , L (Front Left)

調整箇所 : 電源PCB(PA01)の半固定抵抗6箇所

測定箇所・スピーカー・ターミナル名	調整箇所・半固定抵抗シンボル名
RS	R720
LS	R719
C	R760
SW	R759
R	R920
L	R919

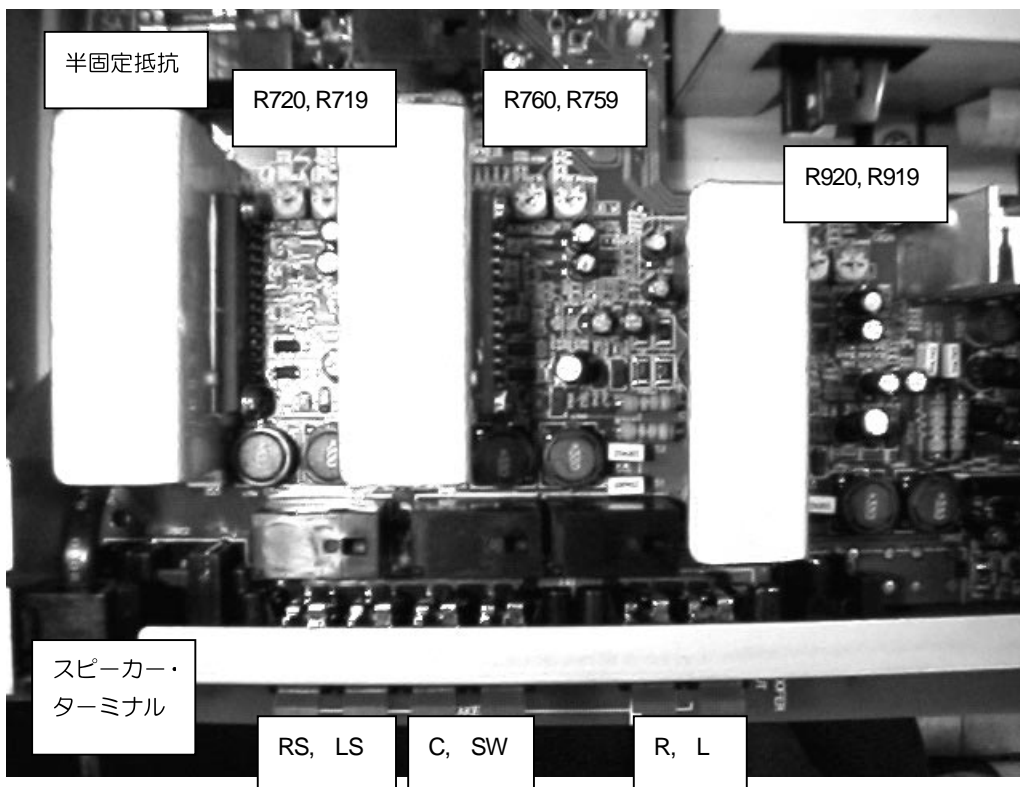

- 確認方法
- 1) 各スピーカー・ターミナルにテスター棒をさす。
 - 2) 各々の半固定抵抗をメカニカル・センターより時計方向または反時計方向に徐々に回していき、各々のスピーカー・ターミナルのDC電圧が約0Vより $\pm 2 \sim 3$ V以上になった時にスピーカー保護回路が動作してリレー(L706, L746, L906)がOFFする事を確認する。この時リレーが跳ねる音(カッチン)がしてスピーカー・ターミナルは開放状態となりテスターの指示電圧が0Vになる。
 - 3) 再度、半固定抵抗をメカニカル・センターに戻す。
 - 4) POWERボタンを2回押し電源を入れ直す。
 - 5) スピーカー保護回路が解除されリレー(L706, L746, L906)がONする事を確認する。この時リレーが跳ねる音(カッチン)がする。

- 調整方法
- 1) スピーカー保護回路のリレー動作が確認出来たらオフセット電圧の調整を行なう。
 - 2) 各々の半固定抵抗を回して各々のスピーカー・ターミナルのDC電圧を $0V \pm 50mV$ 以内に調整する。

4. 電源保護回路の確認

- 入力信号 : テスト・ディスク(JVC製VT-501)を再生
 セットの状態 : POWERON, DVDディスク再生

- 確認方法
- 1) すべてのスピーカー・ターミナルに 6Ω 負荷を接続する。
 - 2) マスター・ボリュームをMINにする。
 - 3) テスト・ディスクでタイトル#50・チャプター#61(L, C, R, LS, RS = 997Hz/0dBfs, LFE = $-\infty$)を再生する。
 - 4) マスター・ボリュームを上げていきMAXにする。
 - 5) 電源保護回路が動作し全てのリレー(L807, L808, L706, L746, L906)が跳ねる音(カッチン)して、電源がOFFする事を確認する。(STANDBY LEDも消灯する。)
 - 6) ACプラグを抜き5分以上放置し電源保護回路が解除されるのを待つ。(ケミコン(C811)の電荷が放電されると電源保護回路が解除される。ケミコン(C811)が完全に放電される前にACプラグを入れた場合は、充電されてしまうのでACプラグを抜き再度5分以上放置する。)
 - 7) 再度、ACプラグを入れるとSTANDBY LEDが点灯し、POWERボタンを押すと正常に電源が入る事を確認する。

5. STANDBY時のビデオ出力端子（映像、音声）確認

- 入力信号 : BSデジタル入力端子
(映像) : ビデオ信号
(音声) : アナログ・オーディオ信号 (L/R 両方)
- セットの状態 : STANDBY
- 測定器 : オシロ・スコープまたは VIDEO/AUDIO 入力付き TV
- 確認箇所 : ビデオ出力の映像と音声 / (L R 両方) 端子
- 確認方法 : BSデジタル入力と同じ映像音声 (L/R) が出力されている事を確認する。

6. 光デジタル入力の確認

- 入力信号 : 光デジタルの BSデジタル入力端子にデジタル音声信号を入力
- セットの状態 : POWER ON, BS DIGITAL モード
- 確認箇所 : BSデジタル入力端子
FLD の表示
- 確認方法 1) 光 BS デジタル入力端子にオプチカル・ケーブルで他の光デジタル出力を持った機器に接続する。
2) BS DIGITAL ボタンを押して BS デジタルを選択する。
3) デジタル入力と同じアナログ音声信号がスピーカーから出力される事を確認する。
4) FLD に「DIG - IN」が表示される事を確認する。

7. 光デジタル出力の確認

- 入力信号 : テスト・ディスク (日本オーディオ協会 AUDIO CHECK DVD-V1) を再生
- セットの状態 : POWERON, DVD ディスク再生
- 確認箇所 : 光デジタル出力端子
- 確認方法 1) 光デジタル出力端子をオプチカル・ケーブルで他の光デジタル入力を持った機器に接続する。
2) 接続先の音声出力から DVD 再生音出力される事を確認する。

8. dtsの確認

- 入力信号 : テスト・ディスク (AUDIOCHECK DVD-V1) を再生
- セットの状態 : POWERON, DVD ディスク再生
- 確認箇所 : スピーカー出力端子
FLD の表示
- 確認方法 1) テスト・ディスクで dts のタイトル #4 を選択し再生する。
スピーカーから DVD 再生音が出力される事を確認する。
3) FLD に「dts」が表示される事を確認する。

9. AACの確認

入力信号 : テスト・ディスク (MJI 製 AAC Test Disc for ER3000 [Part No. : *ER3000AAC]) を再生

セットの状態 : POWER ON CD再生

確認箇所 : スピーカー出力端子
FLDの表示

確認方法 1) テスト・ディスクで AACのトラック #1~6 を選択し再生する。
2) スピーカーから CD再生音が出力される事を確認する。
3) FLD に「AAC」が表示される事を確認する。

注意 : 再生中に音飛びやトラック・ジャンプした時にノイズ音が出るが、テスト・ディスクの問題でセットの不良ではない。

10. 電源コンセントの確認

セットの状態 : POWER ON または STANDBY

確認箇所 : 背面パネルの電源コンセント (ACアウトレット)

確認方法 1) 電源コンセントに外部負荷を接続する。
2) POWERボタンを押し STANDBY 状態にしたとき外部負荷の電源が OFFする事を確認する。
3) POWERボタンを押し POWER ON 状態にしたとき外部負荷の電源が ONする事を確認する。

注意 : 外部負荷は 100V/100W以下の電化製品

11. ヘッドフォンの確認

入力信号 : テスト・ディスク (AUDIO CHECK DVD - V1) を再生

セットの状態 : POWER ON, DVD ディスク再生

確認箇所 : スピーカー出力端子
ヘッドフォン・ジャック
FLDの表示

確認方法 1) DOLBY DIGITALまたは dts のトラック再生中にヘッドフォンのプラグをヘッドフォン・ジャックに差し込む。
この時リレー (L706, L746, L906) が OFFし跳ねる音 (カッチン) がする。
2) スピーカーより音声が出力されずにヘッドフォンよりステレオ音声が出力される事を確認する。
3) FLD の表示に「Dolby DIGITAL」または「dts」に加えて「STEREO」が点灯する事を確認する。

12. マスター・ボリュームの確認

入力信号 : テスト・ディスク (AUDIO CHECK DVD-V1) を再生

セットの状態 : POWER ON, DVD ディスク再生

確認箇所 : スピーカー出力端子またはヘッドフォン・ジャック
FLDの表示

確認方法 : マスター・ボリュームを回すと音量が変化し、FLDの表示が「VOLUME xx」になる事を確認する。(xxはボリュームのレベル : MIN, 01~ 60 MAX)

13. Factory Modeでの確認

ここではFactory Mode を使い TUNER, FLD 表示、REGION などの確認を行う。

- 手順
- 1) STANDBY 状態中に PAUSE ボタンと FM/AM ボタンを同時に押しながら POWER ボタンを押し電源を入れる。
 - 2) Factory Mode の No.0 のニュートラル状態に入る。
(リモコン・コード RC166363 でも同様に No.0 のニュートラル状態に入る)
 - 3) FLD にマイコン・ファームウェアのバージョン名「0_MA_Vxxxx」が表示される。
(xxxx はバージョン番号：0001～9999)
 - 4) 次に、FM/AM ボタンを押すと「TUNER テストモード」に移行する。
NEXT/PREV ボタンを押すと「No.1～6 テストモード」に移行する。
PAUSE ボタンと DVD ボタンを同時に押すと「REGION チェックモード」に移行する。
(Cf.: 15 章 F low Chart of Factory Mode)

13.1 TUNER テストモード

- 手順
- 1) ニュートラル状態のとき FM/AM ボタンを押す。
 - 2) TUNER の PRESET メモリーに自動的に FM または AM の周波数がストアされる。(下記の表通り。)
 - 3) F/P ボタン (PAUSE ボタン) を押して PRESET モードにする。
 - 4) NEXT/PREV ボタンを押して PRESET No.1～13 を選択し各々の周波数が受信出来る事を確認する。
 - 5) 確認が終了したら DVD ボタンを押しニュートラル状態にする。

PRESET No.	BAND	周波数	PRESET No.	BAND	周波数	PRESET No.	BAND	周波数
1	FM	78.0MHz	11	AM	1531kHz	21	--	--
2	FM	83.0MHz	12	AM	1531kHz	22	--	--
3	FM	88.0MHz	13	AM	1531kHz	23	--	--
4	FM	76.0MHz	14	--	--	24	--	--
5	AM	603kHz	15	--	--	25	--	--
6	AM	999kHz	16	--	--	26	--	--
7	AM	1080kHz	17	--	--	27	--	--
8	AM	1404kHz	18	--	--	28	--	--
9	AM	1531kHz	19	--	--	29	--	--
10	AM	1531kHz	20	--	--	30	--	--

13.2 FLD 表示とKEY 入力などの確認

- 手順
- 1) ニュートラル状態のとき NEXT/PREV ボタンを押してテスト No.1～6 を選択する。
 - 2) 各チェック項目を 13.2.1～13.2.6 章の手順に従い確認する。
 - 3) 各項目の確認が終了したら NEXT/PREV ボタンを押してテスト No.0 を選択しニュートラル状態にする。

注意 :ニュートラル状態以外では POWER ボタン押しでも機能しません。

操作	テスト No.	チェック内容
NEXT/PREV ボタン を押してテスト No. 0～6 を 選択します。	0	ニュートラル状態
	1	FLD, LED Check (Except STANDBY LED)
	2	FLD Bit Pattern Check
	3	Key Input Check
	4	Remote Command Receive Check
	5	OSD & Tag Check
	6	Audio Mute Check

13.2.1 FLD と LED 全点灯の確認 (1)

手順 : NEXT/PREV ボタンを押して No.1 を選択する。

確認 : FLDの表示が白色に、ボタンのLEDが緑色に全点灯する事を確認する。

13.2.2 FLD ピット・パターンの確認 (2)

手順 : NEXT/PREV ボタンを押して No.2 を選択する。

確認 : FLDピット・パターンのセグメントが左より右へ順番に表示する事を確認する。

13.2.3 各キー入力の確認 (3)

手順 1) NEXT/PREV ボタンを押して No.3 を選択する。
2) FLD に「3」が表示される。
3) 各々のボタンを押す。

確認 1) POWER ON/STADBY ボタンを押している間だけ FLD, に「3 POWER」が表示される。
2) SURROUND ボタンを押している間だけ、FLD に「3 SURROUND」が表示される。
3) DVD ボタンを押している間だけ、FLD に「3 DVD」が表示される。
4) VIDEO ボタンを押している間だけ、FLD に「3 VIDEO」が表示される。
5) BSDIGITAL ボタンを押している間だけ、FLD に「3 BS-D」が表示される。
6) TV ボタンを押している間だけ、FLD に「3 TV」が表示される。
7) FM/AM ボタンを押している間だけ、FLD に「3 FM/AM」が表示される。
8) OPEN/CLOSE ボタンを押している間だけ、FLD に「3 OPEN」が表示される。
9) PLAY ボタンを押している間だけ、FLD に「3 PLAY」が表示される。
10) STOP ボタンを押している間だけ、FLD に「3 STOP」が表示される。
11) PAUSE ボタンを押している間だけ、FLD に「3 PAUSE」が表示される。
12) NEXT/PREV ボタンは、テスト No.0～6 の選択が出来れば OK とする。

13.2.4 リモコン受信の確認 (4)

手順 1) NEXT/PREV ボタンを押して No.4 を選択する。
2) FLD に「4RC」が表示される。

確認 : リモコン(RC3000ERF)の電源ボタンを押している間だけ、FLD に「4RC 1612」が表示する事を確認する。

13.2.5 OSD 表示が日本語かつ ER3000 仕様である事の確認 (5)

手順 1) NEXT/PREV ボタンを押して No. 5 を選択する。
2) FLD に「5」が表示される。
3) モニター・ディスプレイに初期設定が OSD 表示される。

確認 : OSD 表示メニューのタグが「音声、映像、言語、一般」と日本語で書かれている事を確認する。(ER3000 仕様とは音声のタグが「音声」であり「音声 1、音声 2」で無い事。)

13.2.6 Audio Muteの確認 (6)

手順 1) NEXT/PREV ボタンを押して No. 6 を選択する。
2) DSP から各チャンネルに順番にテスト・トーン(ピンク・ノイズ)が出力される。
3) FLD に「6 MUTE_OFF」が表示される。

確認 : STOP ボタンを押している間だけ、FLD に「6 MUTE_ON」と表示され、テスト・トーンがミュートをされる事を確認する。
(リモコン(RC3000ERF)の停止ボタンまたは消音ボタンを押しても同様にミュートをされる。)

注意 : テスト・トーン出力中に PREV ボタンを押して Audio Mute 確認モードより抜けてもテスト・トーンは止まりません。Audio Mute 確認終了後は NEXT ボタンを押してニュートラル状態にして下さい。

13.3 Region 番号の確認

手順 1) ニュートラル状態のとき PAUSE ボタンと DVD ボタンを同時に押す。
2) FLD に「REGION」が表示される。
3) モニター・ディスプレイに DVD エンジン情報が OSD 表示(英語)される。

確認 : OSD 表示の画面中央右側の Region 番号が「REG: 02」である事を確認する。

13.4 EEPROM メモリーの初期化とSTANDBY LED の確認

手順 : Region Check 中に POWER ボタンを押す。この時 EEPROM メモリーも初期化される。

確認 : STANDBY 状態になり FLD 表示とボタン LED が消灯し、STANDBY LED が赤色に点灯する事を確認する。

14. すべてのメモリー初期化と工場出荷状態

最後にすべてのメモリー (EEPROM, DV ユニットの RAM) を初期化する。
これにより工場出荷状態になる。

手順 : STANDBY 状態中に STOP ボタンを押しながら POWER ボタンを押して電源を入れる。

15. Flow Chart of Factory Mode

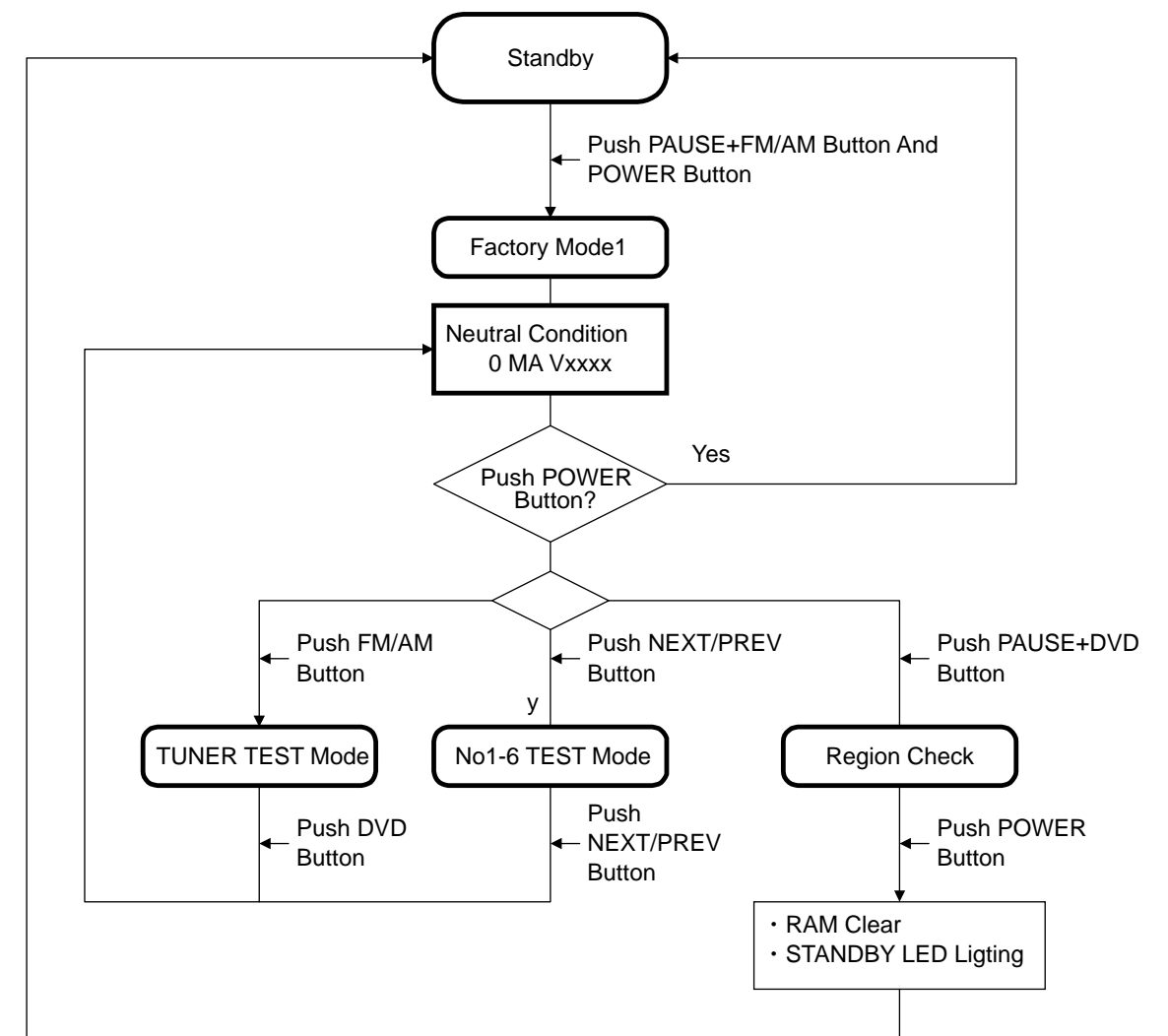

1.8 EXPLODED VIEW AND PARTS LIST

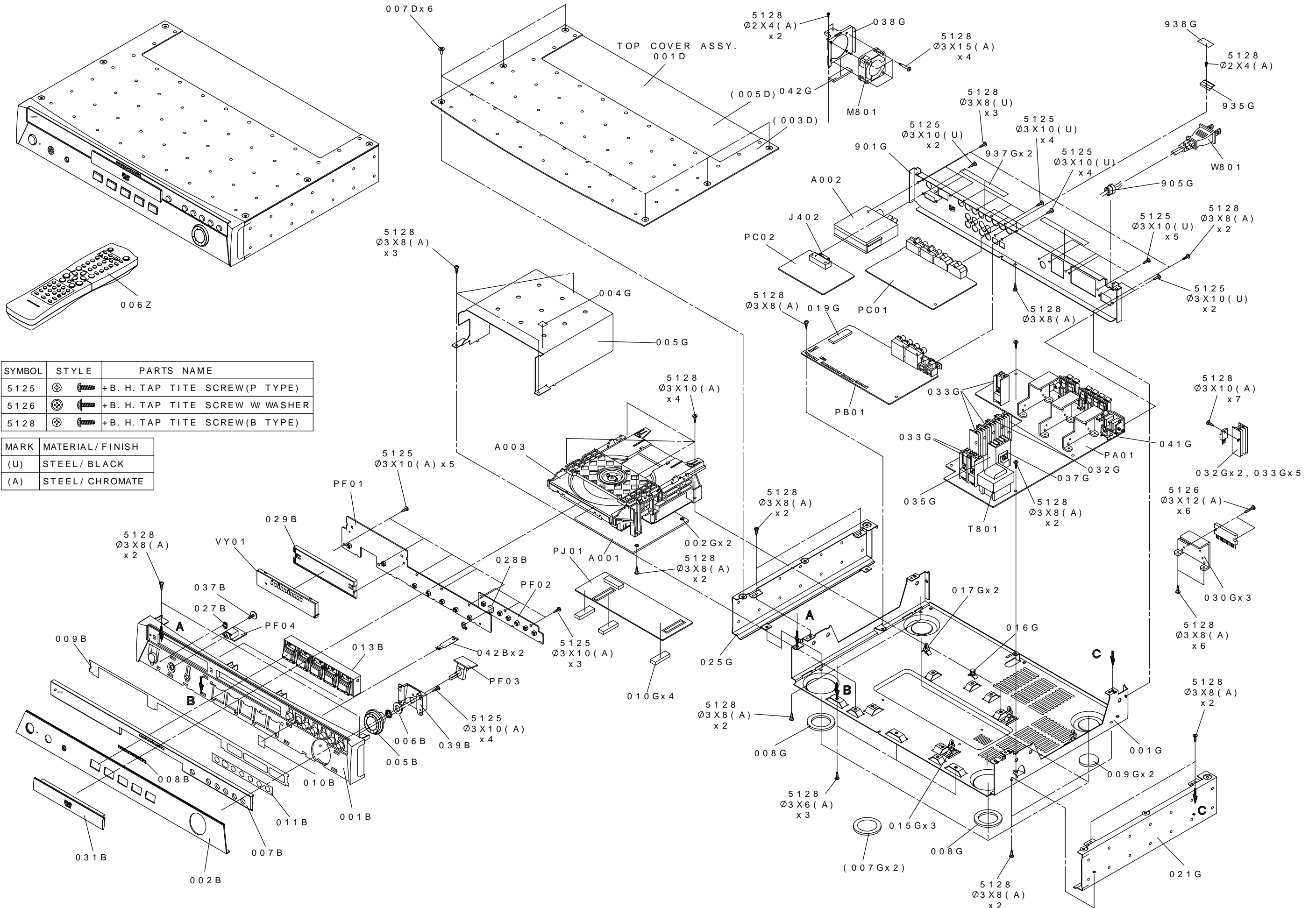

SYMBOL	STYLE	PARTS NAME
5125	⊕	+B. H. TAP TITE SCREW(P TYPE)
5126	⊕	+B. H. TAP TITE SCREW W/ WASHER
5128	⊕	+B. H. TAP TITE SCREW(B TYPE)

MARK	MATERIAL/ FINISH
(U)	STEEL/ BLACK
(A)	STEEL/ CHROMATE

POS. NO	VERS. COLOR	DESCRIPTION	PART NO. (MJ)
001B		KGW1A307M7ZK107 FRONT PANEL	400K248010
002B		KKM1A108ZC30 FRONT AL PANEL	400K063010
005B		BGX1A303ZA VOL KNOB ASSY	400K154500
007B		WINDOW	400K158020
008B	BGB1A097	MZ BADGE FOR WINDOW	313J251030
009B		ADHESIVE FOR WINDOW	400K122110
010B	KGX1A307	IR FILTER	400K107040
011B		BLIND SHEET	400K107120
013B	KBT1A759ZA	FUNCTION BUTTON ASSY	400K270500
027B	KGL1A191A18	LENS FOR STANDBY	400K355010
031B	KGR1A224M7H39	ESCUTCHEON FOR TRAY	400K063020
001D	KKC1A117ZA	TOP LID ASSY	400K257500
007D	BHD1A031	SCREW(TOP LID FIX)	318K010020
007G	KHG1A039Z	FOOT RUBBER ASSY (FRONT & REAR)	400K107500
021G	KUC1A031K111	SIDE PANEL(R)	400K249010
025G	KUC1A030K111	SIDE PANEL(L)	400K249020
905G	KHR1A028	AC CORD BUSH (SAM JIN SJCH-1)	400K259010
A001	BOP11432B	DB-VPB211 DVD PCB MODULE	ZK324J0210
A002	BNVTFCE1J101A	TFCE1J101A TUNER UNIT FOR JAPAN	AV01201140
▲ W801	BJA2J049Z	AC CORD F OR U	*YC000520R
A003		NOT STANDARD SPARE PARTS BJDDB-VLD210 DB-VLD210 DVD LOADER	402K304500

NOTE : "nsp" PART IS LISTED FOR REFERENCE ONLY, MARANTZ WILL NOT SUPPLY THESE PARTS.

SW10 (SUB WOOFER)

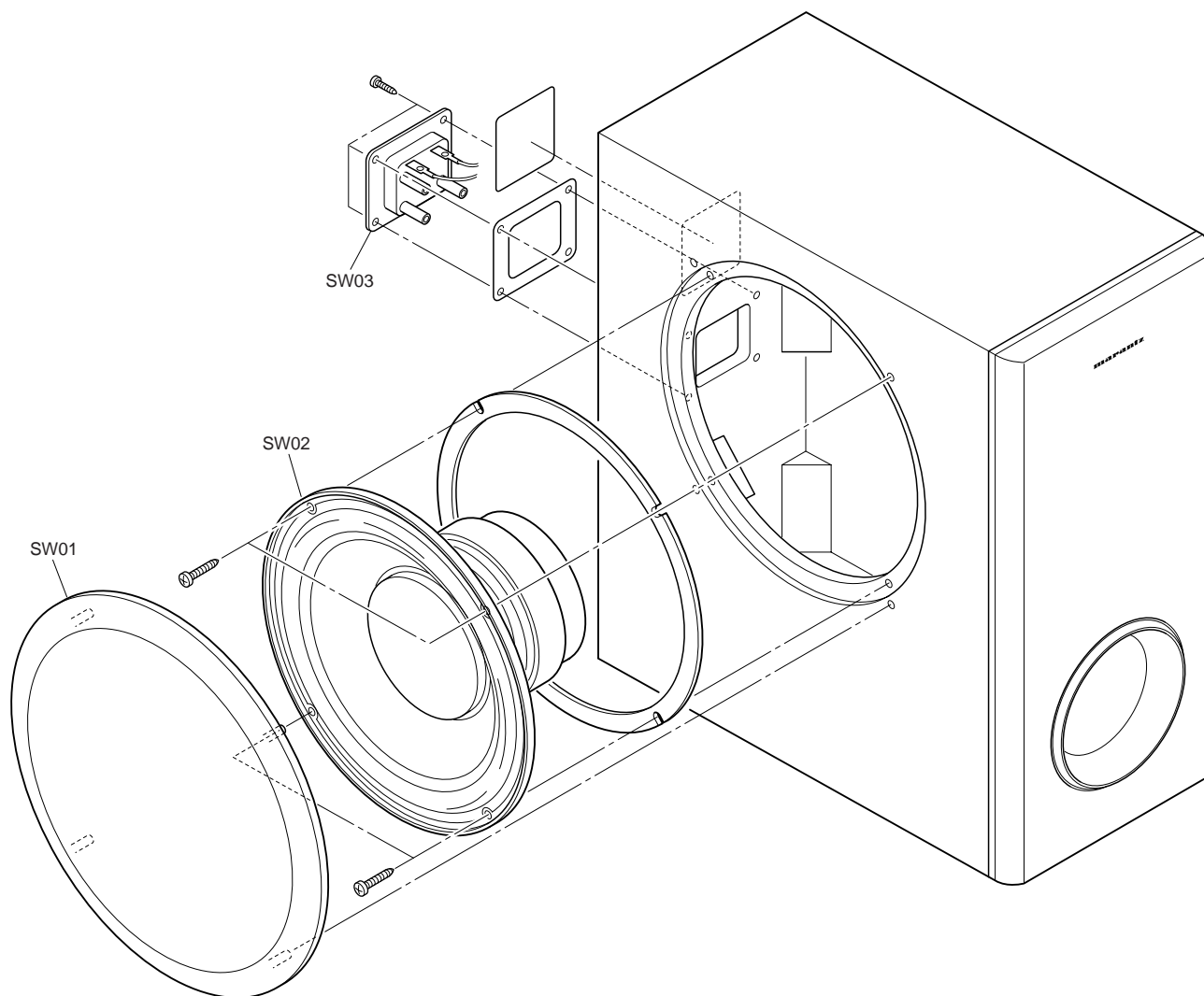

POS. NO	VERS. COLOR	DESCRIPTION	PART NO. (MJ)
SW01		SW10NET NET ASSY (SW10)	400K202510
SW02		KA320LP185SOZ WOOFER UNIT (SW10)	*QK000050R
SW03		KJJ3N012 SPEAKER TERMINAL	*YT002340R

NOTE : "nsp" PART IS LISTED FOR REFERENCE ONLY, MARANTZ WILL NOT SUPPLY THESE PARTS.

LS100/LS100C (SATELLITE)

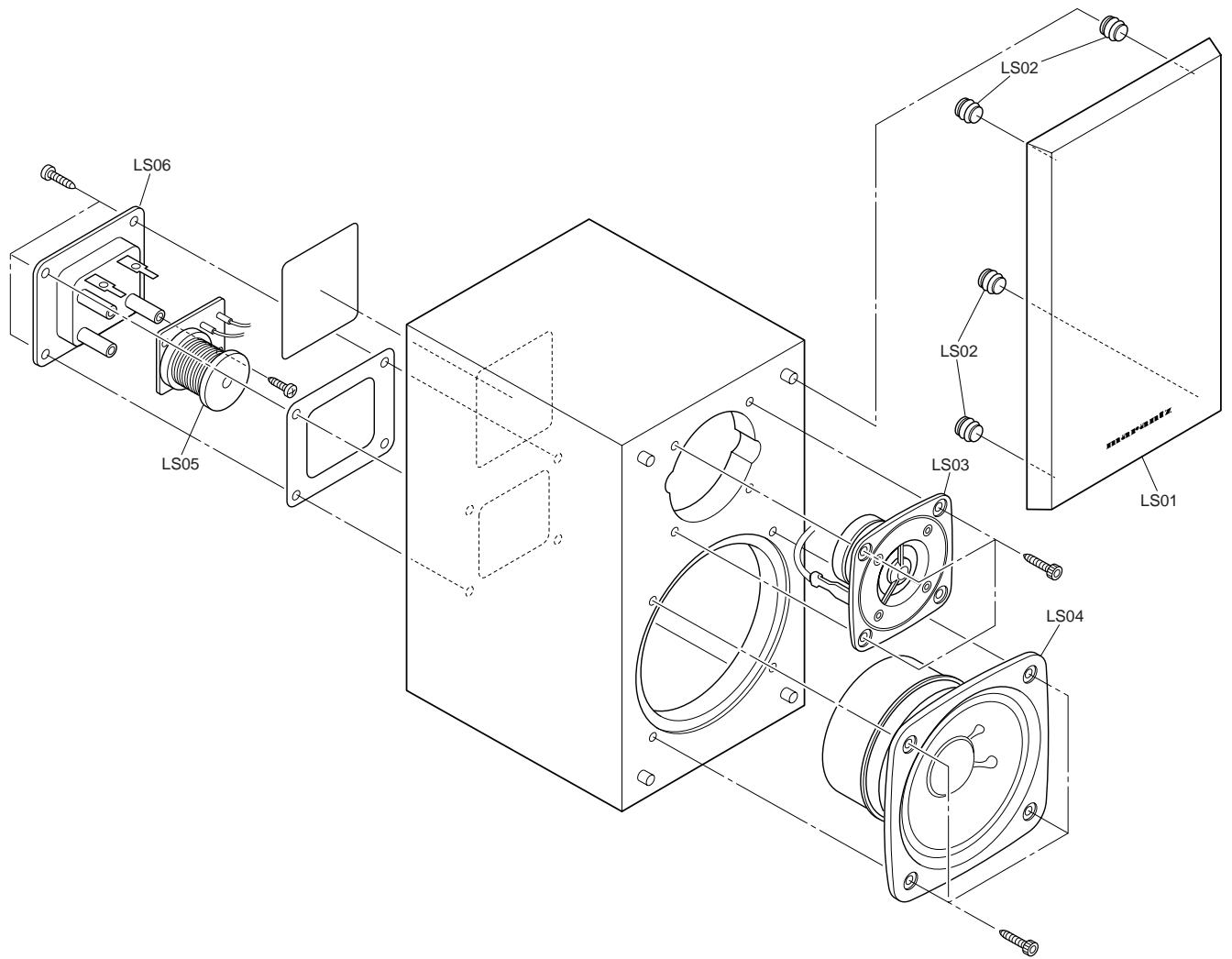

POS. NO	VERS. COLOR	DESCRIPTION	PART NO. (MJI)
LS01		LS100NET NET ASS'Y (LS100)	400K202520
LS01		LS100CNET NET ASS'Y (LS100C)	400K202530
LS02		KHG1A187 NET HOLDER (LS100/LS100C)	400K259010
LS03		KAS1HK183SYZA TWEETER ASS'Y (LS100/LS100C)	*QK000060R
LS04		KAS9LP184SOZA WOOFER ASS'Y (LS100/LS100C)	*QK000070R
LS05		KSN1ALS100 NETWORK ASS'Y (LS100/LS100C)	*ZZ001730R
LS06		KJJ3N012 SPEAKER TERMINAL	*YT002340R

NOTE : "nsp" PART IS LISTED FOR REFERENCE ONLY, MARANTZ WILL NOT SUPPLY THESE PARTS.

POS. NO	VERS. COLOR	DESCRIPTION	PART NO. (MJ)
001T		PACKING KQX1A673Z USER GUIDE	400K851110
006Z		BARTER3000F1S REMOTE CONTROLLER RC3000ERF	AZ400K02F0
		NOT STANDARD SPARE PARTS	
001S		KPG1A632Z PACKING CASE (UNIT)	400K801010
003S		KPS1A515 CUSHION(SPK,BOTTOM)	400K809010
005S		KPS1A516 CUSHION(SPK,CENTER)	400K809020
007S		KPS1A517 CUSHION(SPK, TOP)	400K809030
009S		CUSHION(UNIT,FRONT)	400K809040
011S		CUSHION(UNIT,REAR)	400K809050
013S		KQB1A323Z SHIPPING LABEL	nsp
015S		KPB1A013Y POLYETHYLENE BAG (ER3000)	nsp
017S		KPS1A634 PACKING CASE (SPEAKER)	400K801020
019S		KPG1A633Z MASTER CARTON	400K805010
020S		POLY BAG (SATELLITE SPEAKER)	nsp
021S		POLY BAG (SUB WOOFER)	nsp
002T		FLY SHEET(SPK)	400K851120
003T		BQE1A133Z WARRANTY(F)	nsp
004T		USERS CARD	nsp
005T		KPB1061Y POLY BAG FOR INST	nsp
020T		POLY BAG FOR INST (SPEAKER)	nsp
001Z		KSA267 FM ANTENNA	nsp
002Z		KLR1T201 ANTENNA ADAPTER	nsp
003Z		KSA3A013Z LOOP ANTENNA	nsp
004Z		KABAAM1.5V BATTERY R6P KR CP-2	nsp
005Z		KJS4M011Y VIDEO CABLE (YELLOW) 2.0M	nsp
007Z		KWX1A020 & SPEAKER CABLE KIT KWX1A021	nsp
011Z		ATTACHED LABEL	nsp

NOTE : "nsp" PART IS LISTED FOR REFERENCE ONLY, MARANTZ WILL NOT SUPPLY THESE PARTS.

PACKING

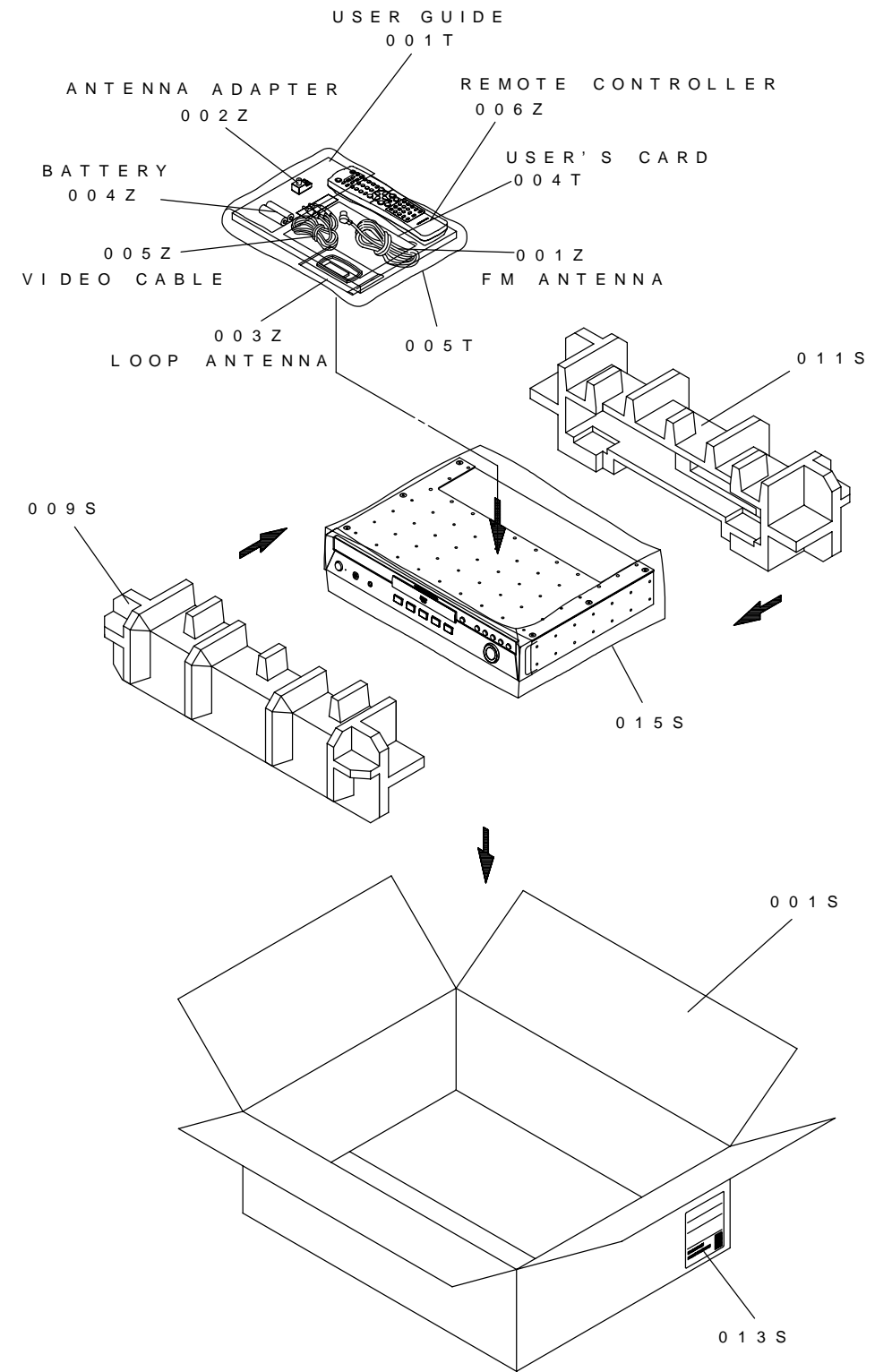
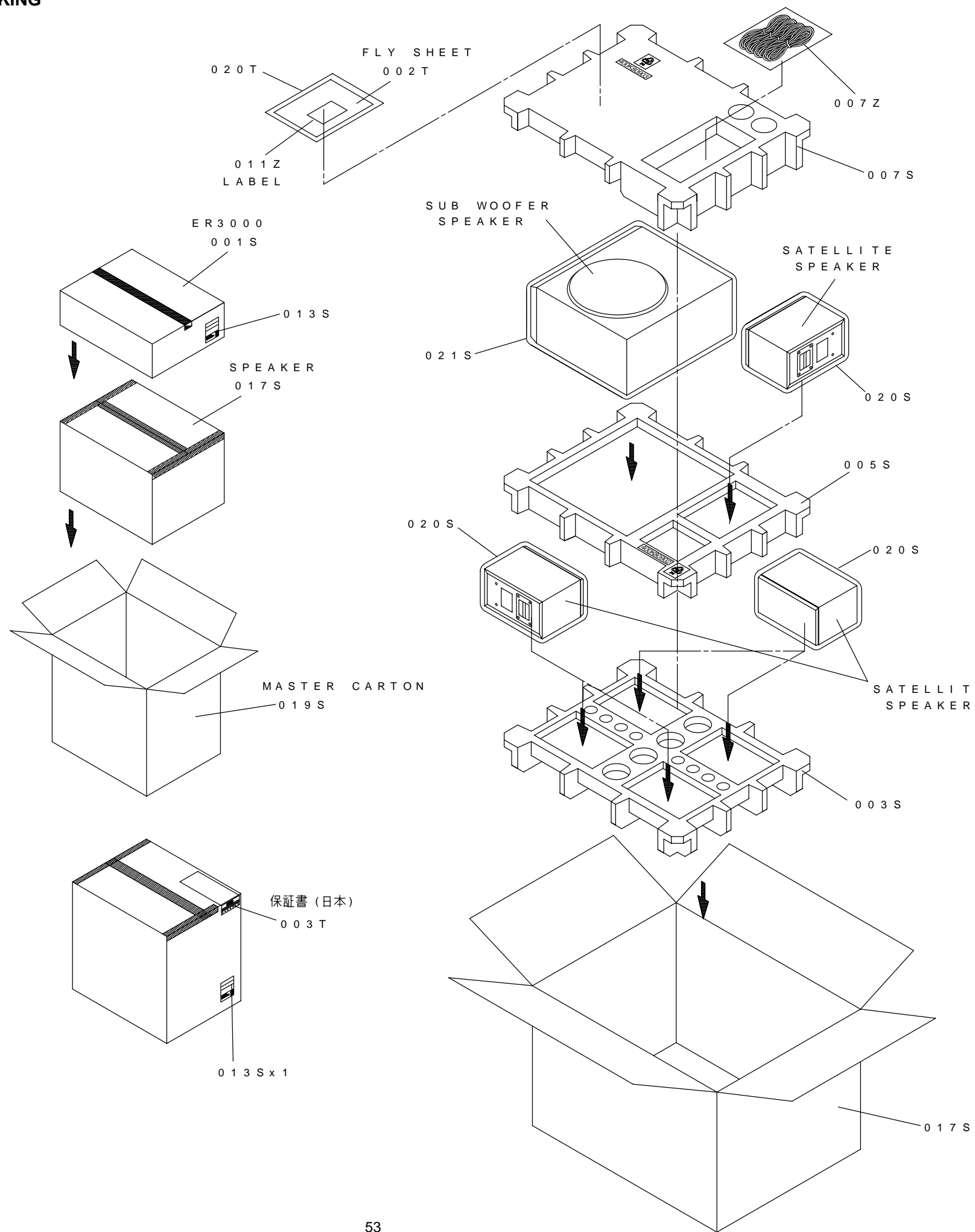

1.9 TAKING OUT THE DISC FOR EMERGENCY

緊急時の DISC の取り出し方法

(機器の電源が入らず、DISCが取り出せなくなった場合)

1. トップカバー(001D)を取り外します。(Fig.1 参照)
2. ギヤーを矢印方向へ手で回します。(Fig.2 参照)
3. DISCトレーが少し手前に出てきます。
4. DISCトレーを手で手前に引き出します。
5. DISCを取り出します。

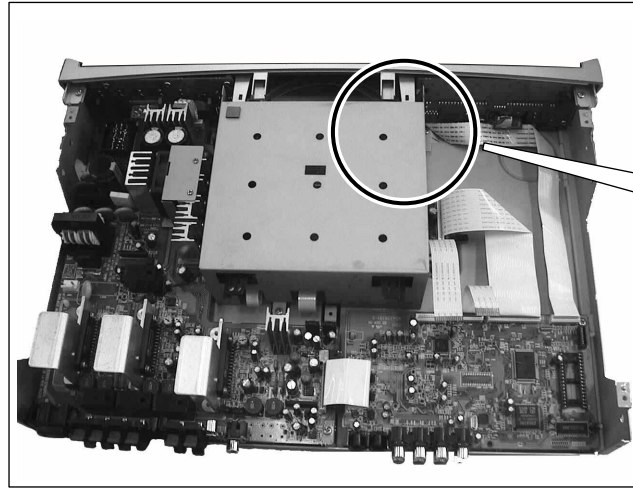

Fig.1

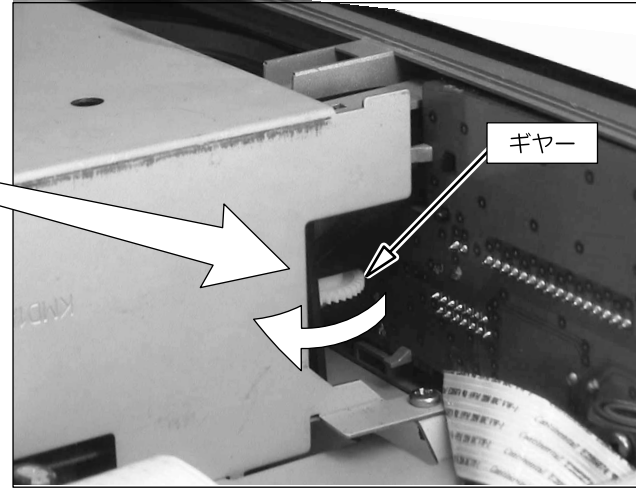

Fig.2

10. ELECTRICAL PARTS LIST

ASSIGNMENT OF COMMON PARTS CODES. RESISTORS

R*** : 1) GD05 x x x 140, Carbon film fixed resistor, ±5% 1/4W
 R*** : 2) GD05 x x x 160, Carbon film fixed resistor, ±5% 1/6W
 ↓ Resistance value

Examples

① Resistance value
 0.1Ω 001 10Ω 100 1kΩ 102 100kΩ 104
 0.5Ω 005 18Ω 180 2.7kΩ 272 680kΩ 684
 1Ω 010 100Ω 101 10kΩ 103 1MΩ 105
 6.8Ω 068 390Ω 391 22kΩ 223 4.7MΩ 475

Note : Please distinguish 1/4W from 1/6W by the shape of parts used actually.

CAPACITORS

C*** : CERAMIC CAP.

3) DD1 x x x x 370, Ceramic capacitor
 ↓ Disc type
 ↓ Temp.coef. P350~N1000, 50V
 ↓ Capacity value
 ↓ Tolerance

Examples

② Tolerance (Capacity deviation)
 ±0.25 pF 0
 ±0.5 pF 1
 ±5% 5
 Tolerance of COMMON PARTS handled here are as follows :
 0.5 pF - 5 pF ± 0.25 pF
 6 pF - 10 pF ± 0.5 pF
 12 pF - 560 pF ± 5%

③ Capacity value

0.5 pF 005 3 pF 030 100 pF 101
 1 pF 010 10 pF 100 220 pF 221
 1.5 pF 015 47 pF 470 560 pF 561

C*** : CERAMIC CAP.

4) DK16 x x x 300, High dielectric constant ceramic capacitor
 ↓ Disc type
 ↓ Temp.chara. 2B4, 50V
 ↓ Capacity value

Examples

④ Capacity value
 100 pF 101 1000 pF 102 10000 pF 103
 470 pF 471 2200 pF 222

C*** : 5) ELECTROLY CAP. (, 6) FILM CAP. ()

5) EA x x x x x 10, Electrolytic capacitor
 ↓ One-way lead type, Tolerance ±20%
 ↓ Capacity value
 ↓ Working voltage

Examples

⑤ Capacity value
 0.1 μF 104 4.7 μF 475 100 μF 107
 0.33 μF 334 10 μF 106 330 μF 337
 1 μF 105 22 μF 226 1100 μF 118
 2200 μF 228
 ⑥ Working voltage
 6.3 V 006 25 V 025
 10 V 010 35 V 035
 16 V 016 50 V 050

6) DF15 x x x 350 → Plastic film capacitor
 DF15 x x x 310 → One-way type, Mylar ±5% 50V
 DF16 x x x 310 → Plastic film capacitor
 ↓ One-way type, Mylar ±10% 50V
 ↓ Capacity value

Examples

⑦ Capacity value
 0.001 μF (1000 pF) 102 0.1 μF 104
 0.0018 μF 182 0.56 μF 564
 0.01 μF 103 1 μF 105
 0.015 μF 153

NOTE 1) The above CODES (R***, R***, C***, C*** and C***) are omitted on the schematic diagram in some case.
 2) On the occasion, be confirmed the common parts on the parts list.
 3) Refer to "Common Parts List" for the other common parts (RI05, DD4, DK4).

NOTE ON SAFETY FOR FUSIBLE RESISTOR :

The suppliers and their type numbers of fusible resistors are as follows ;

1. KOA Corporation
 Part No.(MJI) Type No.(KOA) Description
 NH05 x x x 140 RF25S x x x x Ω J ±5% (1/4W)
 NH05 x x x 120 RF50S x x x x Ω J ±5% (1/2W)
 NH85 x x x 110 RF73B2A x x x x Ω J ±5% (1/10W)
 NH95 x x x 140 RF73B2E x x x x Ω J ±5% (1/4W)
 ↓ Resistance value ↓ Resistance value(0.1Ω - 10kΩ)

2. Matsushita Electronic Components Co., Ltd
 Part No.(MJI) Type No.(MEC) Description
 NF05 x x x 140 ERD-2FCJ x x x (±5% 1/4W)
 RF05 x x x 140 ERD-2FCG x x x (±2% 1/4W)
 NF02 x x x 140 ERD-2FCG x x x (±2% 1/4W)
 RF02 x x x 140 ERD-2FCG x x x (±2% 1/4W)
 ↓ Resistance value



Examples

* Resistance value
 0.1Ω 001 10Ω 100 1kΩ 102 100kΩ 104
 0.5Ω 005 18Ω 180 2.7kΩ 272 680kΩ 684
 1Ω 010 100Ω 101 10kΩ 103 1MΩ 105
 6.8Ω 068 390Ω 391 22kΩ 223 4.7MΩ 475

ABBREVIATION AND MARKS

ANT. : ANTENNA	BATT. : BATTERY
CAP. : CAPACITOR	CER. : CERAMIC
CONN. : CONNECTING	DIG. : DIGITAL
HP : HEADPHONE	MIC. : MICROPHONE
μ-PRO : MICROPROCESSOR	REC. : RECORDING
RES. : RESISTOR	SPK : SPEAKER
SW : SWITCH	TRANSF. : TRANSFORMER
TRIM. : TRIMMING	TRS. : TRANSISTOR
VAR. : VARIABLE	X' TAL : CRYSTAL

NOTE ON SAFETY:

Symbol  Fire or electrical shock hazard. Only original parts should be used to replaced any part marked with symbol  Any other component substitution (other than original type), may increase risk of fire or electrical shock hazard.

安全上の注意 :

 がついている部品は、安全上重要な部品です。必ず指定されている部品番号の部品を使用して下さい。

POS. NO	VERS. COLOR	DESCRIPTION	PART NO. (MJI)	POS. NO	VERS. COLOR	DESCRIPTION	PART NO. (MJI)
		PA01-PWR AMP PWR SUPPLY CIRCUIT BOARD					
		PA01-CAPACITORS					
CN01		KCEA1EH470T ELECT 47μF M 16V	OA47601620	C821		KCUS1H104ZF CER. CHIP 0.1μF F 50V	DK98104300
CN02		KCEA1EH470T ELECT 47μF M 16V	OA47601620	C822		KCEA1CH101T ELECT 100μF M 16V	OA10701620
CN03		KCEA1HHR47T ELECT 0.47μF M 50V	OA47405020	C823		KCEA1CH101T ELECT 100μF M 16V	OA10701620
CN05		KCEA1EH470T ELECT 47μF M 16V	OA47601620	C824		KCUS1H104ZF CER. CHIP 0.1μF F 50V	DK98104300
CN06		KCEA1HH100T ELECT 10μF M 50V	OA10605020	C825		KCEA1AH471T ELECT 470μF M 10V	OA47701020
C701		KCUS1H101JC CER. CHIP 100pF ±5% 50V	DD95101300	C827		KCUS1H104ZF CER. CHIP 0.1μF F 50V	DK98104300
C702		KCUS1H101JC CER. CHIP 100pF ±5% 50V	DD95101300	C828		KCEA1CH101T ELECT 100μF M 16V	OA10701620
C703		KCEA1CAH100T ELECT 10μF M 16V	OA10601620	C829		KCEA1AH471T ELECT 470μF M 10V	OA47701020
C704		KCEA1CAH100T ELECT 10μF M 16V	OA10601620	C830		KCUS1H104ZF CER. CHIP 0.1μF F 50V	DK98104300
C705		KCUS1H561JC CER. CHIP 560pF ±10%	DK96561300	C831		KCUS1H104ZF CER. CHIP 0.1μF F 50V	DK98104300
C706		KCUS1H561JC CER. CHIP 560pF ±10%	DK96561300	C832		KCEA1AH471T ELECT 470μF M 10V	OA47701020
C707		KCUS1H104ZF CER. CHIP 0.1μF 50V F	DK98104300	C833		KCEA1AH471T ELECT 470μF M 10V	OA47701020
C708		KCUS1H104ZF CER. CHIP 0.1μF 50V F	DK98104300	C837		KCUS1H222KB CER. CHIP 2200pF±10%	DK96222300
C709		KCEA1EH470T ELECT 47μF M 16V	OA47601620	C838		KCEA1EH470T ELECT 47μF M 10V	OA47601020
C710		KCEA1EH470T ELECT 47μF M 16V	OA47601620	C839		KCEA1HH101T ELECT 100μF M 50V	OA10705020
C715		KCUS1H102KB CER. CHIP 1000pF ±10% 50V	DK96102300	C840		KCEA1HH220T ELECT 22μF M 50V	OA22605020
C716		KCUS1H102KB CER. CHIP 1000pF ±10% 50V	DK96102300	C841		KCEA1AH471T ELECT 470μF M 10V	OA47701020
C717				C844		KCEA1CH101T ELECT 100μF M 16V	OA10701620
∫		KCUS1H104ZF CER. CHIP 0.1μF F 50V	DK98104300	C901		KCUS1H101JC CER. CHIP 100pF ±5% 50V	DD95101300
C721				C902		KCUS1H101JC CER. CHIP 100pF ±5% 50V	DD95101300
C722		KCEA1VH101T ELECT 100μF M 35V	OA10703520	C903		KCEA1CAH100T ELECT 10μF M 16V	OA10601620
C723		KCUS1H104ZF CER. CHIP 0.1μF F 50V	DK98104300	C904		KCEA1CAH100T ELECT 10μF M 16V	OA10601620
C725		KCEA1VH471E ELECT 470μF M 35V	OA47703520	C905		KCUS1H561JC CER. CHIP 560pF ±10%	DK96561300
C726		KCEA1VH471E ELECT 470μF M 35V	OA47703520	C906		KCUS1H561JC CER. CHIP 560pF ±10%	DK96561300
C727		KCEA1HH220T ELECT 22μF M 50V	OA22605020	C907		KCUS1H104ZF CER. CHIP 0.1μF F 50V	DK98104300
C728		KCEA1HH220T ELECT 22μF M 50V	OA22605020	C908		KCUS1H104ZF CER. CHIP 0.1μF F 50V	DK98104300
C729		KCUS1H104ZF CER. CHIP 0.1μF F 50V	DK98104300	C909		KCEA1EH470T ELECT 47μF M 16V	OA47601620
C730		KCUS1H104ZF CER. CHIP 0.1μF F 50V	DK98104300	C910		KCEA1EH470T ELECT 47μF M 16V	OA47601620
C741		KCUS1H101JC CER. CHIP 100pF ±5% 50V	DD95101300	C915		KCUS1H102KB CER. CHIP 1000pF ±10% 50V	DK96102300
C742		KCUS1H101JC CER. CHIP 100pF ±5% 50V	DD95101300	C916		KCUS1H102KB CER. CHIP 1000pF ±10% 50V	DK96102300
C743		KCEA1CAH100T ELECT 10μF M 16V	OA10601620	C917			
C744		KCEA1CAH100T ELECT 10μF M 16V	OA10601620	∫		KCUS1H104ZF CER. CHIP 0.1μF F 50V	DK98104300
C745		KCUS1H561JC CER. CHIP 560pF ±10%	DK96561300	C921			
C746		KCUS1H561JC CER. CHIP 560pF ±10%	DK96561300	C922		KCEA1VH101T ELECT 100μF M 35V	OA10703520
C747		KCUS1H104ZF CER. CHIP 0.1μF F 50V	DK98104300	C923		KCUS1H104ZF CER. CHIP 0.1μF F 50V	DK98104300
C748		KCUS1H104ZF CER. CHIP 0.1μF F 50V	DK98104300	C925		KCEA1VH471E ELECT 470μF M 35V	OA47703520
C749		KCEA1EH470T ELECT 47μF M 16V	OA47601620	C926		KCEA1VH471E ELECT 470μF M 35V	OA47703520
C750		KCEA1EH470T ELECT 47μF M 16V	OA47601620	C929		KCUS1H104ZF CER. CHIP 0.1μF F 50V	DK98104300
C755		KCUS1H102KB CER. CHIP 1000pF ±10% 50V	DK96102300	C930		KCUS1H104ZF CER. CHIP 0.1μF F 50V	DK98104300
C756		KCUS1H102KB CER. CHIP 1000pF ±10% 50V	DK96102300				
C757						PA01-CAPACITORS(COMMON)	
∫		KCUS1H104ZF CER. CHIP 0.1μF F 50V	DK98104300			PLASTIC FILM CAPACITOR	
C761						±5% 50V : C711-C714	
C762		KCEA1VH101T ELECT 100μF M 35V	OA10703520			C751-C754 C911-C914	
C763		KCUS1H104ZF CER. CHIP 0.1μF F 50V	DK98104300			PA01-RESISTORS	
C765		KCEA1VH471E ELECT 470μF M 35V	OA47703520	RN01		KRJ10DJ683T CHIP 68k Ω ±5% 1/16W	NN05683610
C766		KCEA1VH471E ELECT 470μF M 35V	OA47703520	RN02		KRJ10DJ473T CHIP 47k Ω ±5% 1/16W	NN05473610
C769		KCUS1H104ZF CER. CHIP 0.1μF F 50V	DK98104300	RN03		KRJ10DJ682T CHIP 6.8k Ω ±5% 1/16W	NN05682610
C770		KCUS1H104ZF CER. CHIP 0.1μF F 50V	DK98104300	RN04		KRJ10DJ473T CHIP 47k Ω ±5% 1/16W	NN05473610
				RN05		KRJ10DJ333T CHIP 33k Ω ±5% 1/16W	NN05333610
				RN06		KRJ10DJ473T CHIP 47k Ω ±5% 1/16W	NN05473610
				RN07		KRJ10DJ682T CHIP 6.8k Ω ±5% 1/16W	NN05682610
C805		KCUS1H102KB CHIP 1000pF ±10% B 50V	DK96102300	RN08		KRJ10DJ473T CHIP 47k Ω ±5% 1/16W	NN05473610
▲ C806		KCET2DFHX681ND ELECT 680μF 200V	*EA001040R	RN09		KRJ10DJ473T CHIP 47k Ω ±5% 1/16W	NN05473610
C808		KCUS1H222KB CER. CHIP 2200pF±10%	DK96222300	RN10		KRJ10DJ473T CHIP 47k Ω ±5% 1/16W	NN05473610
C809		KCUS1H333KB CER. CHIP 0.033μF ±10%	DK96333200	RN11		KRJ10DJ471T CHIP 470 Ω ±5% 1/16W	NN05471610
C810		KCEA1HH101T ELECT 100μF M 50V	OA10705020	RN12		KRJ10DJ471T CHIP 470 Ω ±5% 1/16W	NN05471610
C811		KCEA1HH100T ELECT 10μF M 50V	OA10605020	RN13		KRJ10DJ472T CHIP 4.7k Ω ±5% 1/16W	NN05472610
▲ C812		KCEA1VH472E ELECT 4700μF 35V	EA47803510	RN14		KRJ10DJ472T CHIP 4.7k Ω ±5% 1/16W	NN05472610
▲ C813		KCEA1VH472E ELECT 4700μF 35V	EA47803510	RN15		KRJ10DJ222T CHIP 2.2k Ω ±5% 1/16W	NN05222610
▲ C814		KCEA1EH102E ELECT 1000μF 25V	OA10802520	RN16		KRJ10DJ222T CHIP 2.2k Ω ±5% 1/16W	NN05222610
▲ C815		KCEA1EH102E ELECT 1000μF 25V	OA10802520	RN17		KRJ10DJ104T CHIP 100k Ω ±5% 1/16W	NN05104610
C816		KCEA1EH471E ELECT 470μF 25V M	OA47702520	R701		KRJ10DJ473T CHIP 47k Ω ±5% 1/16W	NN05473610
C817		KCEA1AH471T ELECT 470μF M 10V	OA47701020				
C818		KCEA1AH471T ELECT 470μF M 10V	OA47701020	R702		KRJ10DJ473T CHIP 47k Ω ±5% 1/16W	NN05473610
C819		KCEA1HH1R0T ELECT 1μF M 50V	OA10505020	R703		KRJ10DJ102T CHIP 1k Ω ±5% 1/16W	NN05102610
C820		KCUS1H104ZF CER. CHIP 0.1μF F 50V	DK98104300	R704		KRJ10DJ102T CHIP 1k Ω ±5% 1/16W	NN05102610

NOTE : *nsp* PART IS LISTED FOR REFERENCE ONLY, MARANTZ WILL NOT SUPPLY THESE PARTS.

POS. NO	VERS. COLOR	DESCRIPTION	PART NO. (MJI)
R705		KRJ10DJ682T CHIP 6.8k Ω ±5% 1/16W	NN05682610
R706		KRJ10DJ682T CHIP 6.8k Ω ±5% 1/16W	NN05682610
R707		KRJ10DJ223T CHIP 22k Ω ±5% 1/16W	NN05223610
R708		KRJ10DJ223T CHIP 22k Ω ±5% 1/16W	NN05223610
R709		KRJ10DJ103T CHIP 10k Ω ±5% 1/16W	NN05103610
R710		KRJ10DJ103T CHIP 10k Ω ±5% 1/16W	NN05103610
R711		KRJ10DJ122T CHIP 1.2k Ω ±5% 1/16W	NN05122610
R712		KRJ10DJ122T CHIP 1.2k Ω ±5% 1/16W	NN05122610
R713			
∫		KRJ10DJ102T CHIP 1k Ω ±5% 1/16W	NN05102610
R716			
R717		KRJ10DJ122T CHIP 1.2k Ω ±5% 1/16W	NN05122610
R718		KRJ10DJ122T CHIP 1.2k Ω ±5% 1/16W	NN05122610
R719		KVN1RA473B01T SEMI FIXED 47k Ω	RA04730780
R720		KVN1RA473B01T SEMI FIXED 47k Ω	RA04730780
R721		KRJ10DJ562T CHIP 5.6k Ω ±5% 1/16W	NN05562610
R722		KRJ10DJ562T CHIP 5.6k Ω ±5% 1/16W	NN05562610
R723		KRJ10DJ271T CHIP 270 Ω ±5% 1/16W	NN05271610
R724		KRJ10DJ271T CHIP 270 Ω ±5% 1/16W	NN05271610
R725		KRG2SANJ6R8H METAL OXIDE FILM 6.8 Ω ±5% 2W	NK05068020
R726		KRG2SANJ6R8H METAL OXIDE FILM 6.8 Ω ±5% 2W	NK05068020
R728		KRJ10DJ184T CHIP 180k Ω ±5% 1/16W	NN05184610
R729		KRJ10DJ103T CHIP 10k Ω ±5% 1/16W	NN05103610
R730		KRJ10DJ103T CHIP 10k Ω ±5% 1/16W	NN05103610
R731		KRJ10DJ822T CHIP 8.2k Ω ±5% 1/16W	NN05822610
R732		KRJ10DJ102T CHIP 1k Ω ±5% 1/16W	NN05102610
R733		KRJ10DJ473T CHIP 47k Ω ±5% 1/16W	NN05473610
R734		KRJ10DJ473T CHIP 47k Ω ±5% 1/16W	NN05473610
R735		KRJ10DJ103T CHIP 10k Ω ±5% 1/16W	NN05103610
R736		KRJ12EJ102T CHIP 1k Ω ±5% 1/2W	*RI000200R
R737		KRJ12EJ102T CHIP 1k Ω ±5% 1/2W	*RI000200R
R738		KRJ10DJ184T CHIP 180k Ω ±5% 1/16W	NN05184610
R739		KRJ12EJ392T CHIP 3.9k Ω ±5% 1/2W	RI05392120
R740		KRJ12EJ392T CHIP 3.9k Ω ±5% 1/2W	RI05392120
R741		KRJ10DJ473T CHIP 47k Ω ±5% 1/16W	NN05473610
R742		KRJ10DJ473T CHIP 47k Ω ±5% 1/16W	NN05473610
R743		KRJ10DJ102T CHIP 1k Ω ±5% 1/16W	NN05102610
R744		KRJ10DJ102T CHIP 1k Ω ±5% 1/16W	NN05102610
R745		KRJ10DJ682T CHIP 6.8k Ω ±5% 1/16W	NN05682610
R746		KRJ10DJ682T CHIP 6.8k Ω ±5% 1/16W	NN05682610
R747		KRJ10DJ223T CHIP 22k Ω ±5% 1/16W	NN05223610
R748		KRJ10DJ223T CHIP 22k Ω ±5% 1/16W	NN05223610
R749		KRJ10DJ103T CHIP 10k Ω ±5% 1/16W	NN05103610
R750		KRJ10DJ103T CHIP 10k Ω ±5% 1/16W	NN05103610
R751		KRJ10DJ122T CHIP 1.2k Ω ±5% 1/16W	NN05122610
R752		KRJ10DJ122T CHIP 1.2k Ω ±5% 1/16W	NN05122610
R753			
∫		KRJ10DJ102T CHIP 1k Ω ±5% 1/16W	NN05102610
R756			
R757		KRJ10DJ122T CHIP 1.2k Ω ±5% 1/16W	NN05122610
R758		KRJ10DJ122T CHIP 1.2k Ω ±5% 1/16W	NN05122610
R759		KVN1RA473B01T SEMI FIXED 47k Ω	RA04730780
R760		KVN1RA473B01T SEMI FIXED 47k Ω	RA04730780
R761		KRJ10DJ562T CHIP 5.6k Ω ±5% 1/16W	NN05562610
R762		KRJ10DJ562T CHIP 5.6k Ω ±5% 1/16W	NN05562610
R763		KRJ10DJ271T CHIP 270 Ω ±5% 1/16W	NN05271610
R764		KRJ10DJ271T CHIP 270 Ω ±5% 1/16W	NN05271610
R765		KRG2SANJ6R8H METAL OXIDE FILM 6.8 Ω ±5% 2W	NK05068020
R766		KRG2SANJ6R8H METAL OXIDE FILM 6.8 Ω ±5% 2W	NK05068020
R768		KRJ10DJ184T CHIP 180k Ω ±5% 1/16W	NN05184610
R769		KRJ10DJ103T CHIP 10k Ω ±5% 1/16W	NN05103610
R770		KRJ10DJ103T CHIP 10k Ω ±5% 1/16W	NN05103610
R771		KRJ10DJ822T CHIP 8.2k Ω ±5% 1/16W	NN05822610
R772		KRJ10DJ102T CHIP 1k Ω ±5% 1/16W	NN05102610

POS. NO	VERS. COLOR	DESCRIPTION	PART NO. (MJI)
R773		KRJ10DJ473T CHIP 47k Ω ±5% 1/16W	NN05473610
R774		KRJ10DJ473T CHIP 47k Ω ±5% 1/16W	NN05473610
R775		KRJ10DJ184T CHIP 180k Ω ±5% 1/16W	NN05184610
R776			
∫		KRJ10DJ123T CHIP 12k Ω ±5% 1/16W	NN05123610
R779			
R801		KRJ10DJ223T CHIP 22k Ω ±5% 1/16W	NN05223610
R802		KRJ10DJ182T CHIP 1.8k Ω ±5% 1/16W	NN05182610
R803		KRJ10DJ681T CHIP 680 Ω ±5% 1/16W	NN05681610
R804		KRJ10DJ154T CHIP 150k Ω ±5% 1/16W	NN05154610
R805		KRJ10DJ183T CHIP 18k Ω ±5% 1/16W	NN05183610
R806		KRJ10DJ470T CHIP 47 Ω ±5% 1/16W	NN05470610
R808		KRJ10DJ102T CHIP 1k Ω ±5% 1/16W	NN05102610
R811		KRJ10DJ0R0T CHIP 0 Ω ±5% 1/16W	NN05000610
R812		KRJ10DJ102T CHIP 1k Ω ±5% 1/16W	NN05102610
R813		KRJ10DJ153T CHIP 15k Ω ±5% 1/16W	NN05153610
R814		KRJ10DJ102T CHIP 1k Ω ±5% 1/16W	NN05102610
R815		KRJ10DJ153T CHIP 15k Ω ±5% 1/16W	NN05153610
R816		KRJ10DJ0R0T CHIP 0 Ω ±5% 1/16W	NN05000610
R819		KRJ10DJ103T CHIP 10k Ω ±5% 1/16W	NN05103610
R822		KRJ10DJ102T CHIP 1k Ω ±5% 1/16W	NN05102610
R825		KRJ10DJ102T CHIP 1k Ω ±5% 1/16W	NN05102610
R826		KRJ10DJ103T CHIP 10k Ω ±5% 1/16W	NN05103610
R828			
∫		KRJ10DJ103T CHIP 10k Ω ±5% 1/16W	NN05103610
R831			
R832		KRJ10DJ332T CHIP 3.3k Ω ±5% 1/16W	NN05332610
R833		KRJ10DJ102T CHIP 1k Ω ±5% 1/16W	NN05102610
R834		KRJ10DJ222T CHIP 2.2k Ω ±5% 1/16W	NN05222610
R835		KRJ10DJ682T CHIP 2.2k Ω ±5% 1/16W	NN05682610
R836		KRJ10DJ472T CHIP 4.7k Ω ±5% 1/16W	NN05472610
R837		KRJ10DJ223T CHIP 22k Ω ±5% 1/16W	NN05223610
R838		KRJ10DJ223T CHIP 22k Ω ±5% 1/16W	NN05223610
R901		KRJ10DJ473T CHIP 47k Ω ±5% 1/16W	NN05473610
R902		KRJ10DJ473T CHIP 47k Ω ±5% 1/16W	NN05473610
R903		KRJ10DJ102T CHIP 1k Ω ±5% 1/16W	NN05102610
R904		KRJ10DJ102T CHIP 1k Ω ±5% 1/16W	NN05102610
R905		KRJ10DJ682T CHIP 6.8k Ω ±5% 1/16W	NN05682610
R906		KRJ10DJ682T CHIP 6.8k Ω ±5% 1/16W	NN05682610
R907		KRJ10DJ223T CHIP 22k Ω ±5% 1/16W	NN05223610
R908		KRJ10DJ223T CHIP 22k Ω ±5% 1/16W	NN05223610
R909		KRJ10DJ103T CHIP 10k Ω ±5% 1/16W	NN05103610
R910		KRJ10DJ103T CHIP 10k Ω ±5% 1/16W	NN05103610
R911		KRJ10DJ122T CHIP 1.2k Ω ±5% 1/16W	NN05122610
R912		KRJ10DJ122T CHIP 1.2k Ω ±5% 1/16W	NN05122610
R913			
∫		KRJ10DJ102T CHIP 1k Ω ±5% 1/16W	NN05102610
R916			
R917		KRJ10DJ122T CHIP 1.2k Ω ±5% 1/16W	NN05122610
R918		KRJ10DJ122T CHIP 1.2k Ω ±5% 1/16W	NN05122610
R919		KVN1RA473B01T SEMI FIXED 47k Ω	RA04730780
R920		KVN1RA473B01T SEMI FIXED 47k Ω	RA04730780
R921		KRJ10DJ562T CHIP 5.6k Ω ±5% 1/16W	NN05562610
R922		KRJ10DJ562T CHIP 5.6k Ω ±5% 1/16W	NN05562610
R923		KRJ10DJ271T CHIP 270 Ω ±5% 1/16W	NN05271610
R924		KRJ10DJ271T CHIP 270 Ω ±5% 1/16W	NN05271610
R925		KRG2SANJ6R8H METAL OXIDE FILM 6.8 Ω ±5% 2W	NK05068020
R926		KRG2SANJ6R8H METAL OXIDE FILM 6.8 Ω ±5% 2W	NK05068020
R928		KRJ10DJ184T CHIP 180k Ω ±5% 1/16W	NN05184610
R929		KRJ10DJ103T CHIP 10k Ω ±5% 1/16W	NN05103610
R930		KRJ10DJ103T CHIP 10k Ω ±5% 1/16W	NN05103610
R931		KRJ10DJ822T CHIP 8.2k Ω ±5% 1/16W	NN05822610
R932		KRJ10DJ102T CHIP 1k Ω ±5% 1/16W	NN05102610
R933		KRJ10DJ473T CHIP 47k Ω ±5% 1/16W	NN05473610
R934		KRJ10DJ473T CHIP 47k Ω ±5% 1/16W	NN05473610
R935		KRJ10DJ184T CHIP 180k Ω ±5% 1/16W	NN05184610

NOTE : "hsp" PART IS LISTED FOR REFERENCE ONLY, MARANTZ WILL NOT SUPPLY THESE PARTS.

POS. NO	VERS. COLOR	DESCRIPTION	PART NO. (MJI)	POS. NO	VERS. COLOR	DESCRIPTION	PART NO. (MJI)
R936		KRJ10DJ102T CHIP 1k Ω ±5% 1/16W	NN05102610	D908		BVDRB160L60TE25 DIODE RB160L-60 TE25 SBD 60V 1A	*HZ200160R
R937		KRJ10DJ123T CHIP 12k Ω ±5% 1/16W	NN05123610				
R938		KRJ10DJ123T CHIP 12k Ω ±5% 1/16W	NN05123610				
R***		PA01-RESISTORS(COMMON) CARBON FILM FIXED RES. ±5% 1/6W : R807 R809		Q701		KMYBVITA2022ZA IC TA2022-100	HC10140990
		PA01-SEMICONDUCTORS		Q702		BVT2SC2240GRT TRS. 2SC2240 (GR)	HT322401A0
D701		BVDRB160L60TE25 DIODE RB160L-60 TE25 SBD 60V 1A	*HZ200160R	Q741		KMYBVITA2022ZA IC TA2022-100	HC10140990
D702		BVDRB160L60TE25 DIODE RB160L-60 TE25 SBD 60V 1A	*HZ200160R	▲ Q801		BVIAN8037 IC SW REGULATOR AN8037	HC10174020
D703		BVDRB160L40TE25 DIODE RB160L-40 TE25 SBD 40V 1A	HZ20061210	▲ Q802		BRTNTH22D3R0LA THERMISTOR POWER NTH22D3R0LA	HH00006230
D706		KVD1N4003SRT DIODE TW 1N4003S or 1D3	HD200010AR	Q803		KMYBVT2SK270ZA FET 2SK2730	HF22730000
D707		BVDRB160L60TE25 DIODE RB160L-60 TE25 SBD 60V 1A	*HZ200160R	▲ Q804		BVINJM431L IC SHUNT REGULATOR NJM431	HC33136090
D708		BVDRB160L60TE25 DIODE RB160L-60 TE25 SBD 60V 1A	*HZ200160R	▲ Q805		BVINJM78M15FA IC REGULATOR NJM78M15FA(0.5A 15V)	HC3851509F
D741		BVDRB160L60TE25 DIODE RB160L-60 TE25 SBD 60V 1A	*HZ200160R	▲ Q806		BVINJM79M15FA IC REGULATOR NJM79M15FA(0.5A -15V)	HC3951509F
D742		BVDRB160L60TE25 DIODE RB160L-60 TE25 SBD 60V 1A	*HZ200160R	▲ Q807		BVISI8033S IC REGULATOR(SW) SI-8033S	HC91903080
D743		BVDRB160L40TE25 DIODE RB160L-40 TE25 SBD 40V 1A	HZ20061210	Q808		BVTDTC114EUA TRS. CHIP DTC114EU	BA20035210
D747		BVDRB160L60TE25 DIODE RB160L-60 TE25 SBD 60V 1A	*HZ200160R	▲ Q809		KMYBVISI3050CZA IC SI-3050C	HC10006080
D748		BVDRB160L60TE25 DIODE RB160L-60 TE25 SBD 60V 1A	*HZ200160R	Q810		BVTDTC114EUA TRS. CHIP DTC114EU	BA20035210
▲ D801		BVDGBJ604 DIODE BRIDGE RBV-606 400V 6A	HE20004080	▲ Q811		KMYBVISI3050CZA IC SI-3050C	HC10006080
▲ D802		BVIPC123FY IC PHOTO COUPLER PC-123F2	HW10032320	Q812		BVTDTC114EUA TRS. CHIP DTC114EU	BA20035210
D804		BVD1SS301 DIODE CHIP KDS121 or 1SS301	HZ21005000	Q813		BVT2SC2240GRT TRS. 2SC2240 (GR)	HT322401A0
D805		BVD1SS301 DIODE CHIP KDS121 or 1SS301	HZ21005000	Q814		BVT2SC2240GRT TRS. 2SC2240 (GR)	HT322401A0
D806		BVDRB160L40TE25 DIODE RB160L-40 TE25 SBD 40V 1A	HZ20061210	▲ Q815		BVIPQ2TZ15U IC CHIP REGULATOR(2.5V) PQ2TZ15U	HC98903320
D807		KMYBVDFMBG14LZA DIODE FMB-G14L & HEAT SINK ASSY	*HC200120R	▲ Q816		KMYNJM78M05FAZA IC NJM78M05FA	HC3850509F
▲ D808		KMYBVDFMG2SZA DIODE FMG-22S &HEAT SINK ASSY	*HC200130R	▲ Q817		BVINJM79M05FA IC REGULATOR NJM79M05FA -5V 0.5A	HC3950509F
▲ D809		KMYBVDFMG22SZA DIODE FMG-22S &HEAT SINK ASSY	*HC200130R	▲ Q818		KMYNJM7812FAYA IC NJM7812FA +12V	HC3891209F
D810		BVDRB160L40TE25 DIODE RB160L-40 TE25 SBD 40V 1A	HZ20061210	Q819		BVT2SA1576AQ TRS. CHIP 2SA1576(FQ)	HX115761A0
D811		BVDRB160L40TE25 DIODE RB160L-40 TE25 SBD 40V 1A	HZ20061210	▲ Q820		BVIPQ1CZ21H2ZP IC CHIP REGULATOR(SW) PQ1CZ21H2ZP	HC91915320
D812		BVDRB160L40TE25 DIODE RB160L-40 TE25 SBD 40V 1A	HZ20061210	Q821		BVT2SC4213B TRS. CHIP(MUTING/SW) 2SC4213	HX342132A0
D813		BVD1SS301 DIODE CHIP KDS121 or 1SS301	HZ21005000	Q901		KMYBVITA2022ZA IC TA2022-100	HC10140990
D816		BVD1SS301 DIODE CHIP KDS121 or 1SS301	HZ21005000	Q902		BVTDTC114EUA TRS. CHIP DTC114EU	BA20035210
D818		KVD1N4003SRT DIODE TW 1N4003S or 1D3	HD200010AR	QN01		BVITA7317P IC PROTECTOR TA7317P	HC10042050
D819		KVD1N4003SRT DIODE TW 1N4003S or 1D3	HD200010AR	QN02		BVINJM2068M IC OP AMP NJM2068M	HC10102090
D820		BVDUDZ-16B DIODE ZENER UDZ-16B	HZ31601000	QN03		BVT2SC4213B TRS. CHIP(MUTING/SW) 2SC4213	HX342132A0
D821		BVD1SS301 DIODE CHIP KDS121 or 1SS301	HZ21005000	QN04		BVT2SC4213B TRS. CHIP(MUTING/SW) 2SC4213	HX342132A0
D901		BVDRB160L60TE25 DIODE RB160L-60 TE25 SBD 60V 1A	*HZ200160R	QN05		BVTDTA114YUA TRS. CHIP DTA114YU	BA12307000
D902		BVDRB160L60TE25 DIODE RB160L-60 TE25 SBD 60V 1A	*HZ200160R	▲ F801		KBA2C5000NRJ FUSE 5A	FS10500360
D903		BVDRB160L40TE25 DIODE RB160L-40 TE25 SBD 40V 1A	HZ20061210	J702		KJJ5Q009Z TERMINAL SPEAKER (8P RED/BLK)	*YT002290R
D907		BVDRB160L60TE25 DIODE RB160L-60 TE25 SBD 60V 1A	*HZ200160R	J703		KJJ5P014Z TERMINAL SPEAKER CN	*YT002300R
				J704		KJJ4M036Z BOARD JACK (1P BLK) JE010003CN	*YT002310R
				▲ J802		KJJ7A012Z OUTLET AC A2-02-D003-OP	*YJ002350R
				L701		BLZ9J003Z BEAD FERRITE(CHIP) BLM21A05PT	FC90020050
				L702		BLZ9J003Z BEAD FERRITE(CHIP) BLM21A05PT	FC90020050
				L703		KLZ9L001Z COIL CHIP SLF12575-330M3R2	LU80333060
				L704		KLZ9L001Z COIL CHIP SLF12575-330M3R2	LU80333060
				L705		BLZ9M001Z COIL CHIP(100μH K) NLC322522	LU17104010
				L706		BSL3B013ZE RELAY (DC24V) G5PA-28 5A/250VAC	LY20240490
				L741		BLZ9J003Z BEAD FERRITE(CHIP) BLM21A05PT	FC90020050
				L742		BLZ9J003Z BEAD FERRITE(CHIP) BLM21A05PT	FC90020050
						PA01-MISCELLANEOUS	

NOTE : "nsp" PART IS LISTED FOR REFERENCE ONLY, MARANTZ WILL NOT SUPPLY THESE PARTS.

POS. NO	VERS. COLOR	DESCRIPTION	PART NO. (MJI)	POS. NO	VERS. COLOR	DESCRIPTION	PART NO. (MJI)
L743		KLZ9L001Z COIL CHIP SLF12575-330M3R2	LU80333060	CJ41		KCEA1CAH100T ELECT 10μF M 16V	OA10601620
L744		KLZ9L001Z COIL CHIP SLF12575-330M3R2	LU80333060	CJ42		KCEA1CAH100T ELECT 10μF M 16V	OA10601620
L745		BLZ9M001Z COIL CHIP(100μH K) NLC322522	LU17104010	CJ43		KCUS1H102KB CER. CHIP 1000pF ±10% 50V	DK96102300
L746		BSL3B013ZE RELAY (DC24V) G5PA-28 5A/250VAC	LY20240490	CJ44		KCUS1H102KB CER. CHIP 1000pF ±10% 50V	DK96102300
▲ L801		KLFKE0901 FILTER LINE	*FN000120R	CJ45		KCUS1H181JC CER. CHIP 180pF ±5% 50V	DD95181300
L803		KLT470K705CT COIL CHOKE TSL0709-470KR94	*LC107280R	CJ46		KCUS1H181JC CER. CHIP 180pF ±5% 50V	DD95181300
L804		KLT470K705CT COIL CHOKE TSL0709-470KR94	*LC107280R	CK01		KCEA1CH101T ELECT 100μF M 10V	OA10701020
L805		KLT101K705CT COIL CHOKE TSL0709-101KR94	LC11044600	CK02		KCUS1H104ZF CER. CHIP 0.1μF F 50V	DK98104300
▲ L807		BSL3B013ZE RELAY (DC24V) G5PA-28 5A/250VAC	LY20240490	CK03		KCEA1HH2R2T ELECT 2.2μF M 50V	OA22505020
▲ L808		BSL1B012ZE RELAY (DC24V) POWER G5PA-1 5A	LY10240280	CK04		KCUS1H104ZF CER. CHIP 0.1μF F 50V	DK98104300
L901		BLZ9J003Z BEAD FERRITE(CHIP) BLM21A05PT	FC90020050	CK05		KCEA1HH2R2T ELECT 2.2μF M 50V	OA22505020
L902		BLZ9J003Z BEAD FERRITE(CHIP) BLM21A05PT	FC90020050	CK06		KCUS1H104ZF CER. CHIP 0.1μF F 50V	DK98104300
L903		KLZ9L001Z COIL CHIP SLF12575-330M3R2	LU80333060	CK07		KCUS1H104ZF CER. CHIP 0.1μF F 50V	DK98104300
L904		KLZ9L001Z COIL CHIP SLF12575-330M3R2	LU80333060	C601		KCUS1H104ZF CER. CHIP 0.1μF F 50V	DK98104300
L905		BLZ9M001Z COIL CHIP(100μH K) NLC322522	LU17104010	C602		KCUS1H104ZF CER. CHIP 0.1μF F 50V	DK98104300
L906		BSL3B013ZE RELAY (DC24V) G5PA-28 5A/250VAC	LY20240490	C603		KCEA1CH101T ELECT 100μF M 10V	OA10701020
M801		KMD1A441ZA FAN BRACKET ASS'Y	MM01200290	C604		KCUS1H104ZF CER. CHIP 0.1μF F 50V	DK98104300
▲ T801		KLT5K004Z TRANS POWER(40X45)	TS14157010	C605		KCUS1H104ZF CER. CHIP 0.1μF F 50V	DK98104300
		PB01-U-COM DSP CIRCUIT BOARD PB01-CAPACITORS		C606		KCUS1H104ZF CER. CHIP 0.1μF F 50V	DK98104300
CE01		KCEA1HH100T ELECT 10μF M 50V	OA10605020	C607		KCUS1H103KB CER. CHIP 0.01μF ±10% 50V	DK96103300
CE02		KCEA1HH100T ELECT 10μF M 50V	OA10605020	C608		KCUS1H104ZF CER. CHIP 0.1μF F 50V	DK98104300
CE05		KCEA1CAH100T ELECT 10μF M 16V	OA10601620	C609		KCUS1H103KB CER. CHIP 0.01μF ±10% 50V	DK96103300
CE06		KCEA1CAH100T ELECT 10μF M 16V	OA10601620	C610		KCEA1EH470T ELECT 47μF M 10V	OA47601020
CE07		KCUS1H102KB CER. CHIP 1000pF ±10% 50V	DK96102300	C611		KCUS1H103KB CER. CHIP 0.01μF ±10% 50V	DK96103300
CE08		KCUS1H102KB CER. CHIP 1000pF ±10% 50V	DK96102300	C612		KCUS1H220JC CER. CHIP 22pF ±5% 50V	DD95220300
CE09		KCUS1H470JC CER. CHIP 47pF ±5% 50V	DD95470300	C613		KCUS1H220JC CER. CHIP 22pF ±5% 50V	DD95220300
CE12		KCUS1H103KB CER. CHIP 0.01μF ±10% 25V	DK96103200	C614		KCUS1H104ZF CER. CHIP 0.1μF F 50V	DK98104300
CE13		KCUS1H103KB CER. CHIP 0.01μF ±10% 25V	DK96103200	C615		KCUS1H104ZF CER. CHIP 0.1μF F 50V	DK98104300
CE14		KCEA1CH101T ELECT 100μF M 16V	OA10701620	C616		KCUS1H104ZF CER. CHIP 0.1μF F 50V	DK98104300
CE15		KCEA1EH470T ELECT 47μF M 16V	OA47601620	C618		KCEA1CH101T ELECT 100μF M 10V	OA10701020
CE16		KCEA1EH470T ELECT 47μF M 16V	OA47601620	C619		KCUS1H104ZF CER. CHIP 0.1μF F 50V	DK98104300
CE17		KCEA1EH470T ELECT 47μF M 16V	OA47601620	C620		KCUS1H104ZF CER. CHIP 0.1μF F 50V	DK98104300
CG13		KCEA1EH470T ELECT 47μF M 16V	OA47601620	C622		KCUS1H220JC CER. CHIP 22pF ±5% 50V	DD95220300
CG14		KCEA1EH470T ELECT 47μF M 16V	OA47601620	C623		KCUS1H104ZF CER. CHIP 0.1μF F 50V	DK98104300
CG15		KCUS1H104ZF CER. CHIP 0.1μF F 50V	DK98104300	C624		KCEA1CH101T ELECT 100μF M 10V	OA10701020
CG16		KCUS1H104ZF CER. CHIP 0.1μF F 50V	DK98104300	C625		KCEA1CH101T ELECT 100μF M 10V	OA10701020
CJ01		KCEA1CAH100T ELECT 10μF M 16V	OA10601620	C630		KCUS1H104ZF CER. CHIP 0.1μF F 50V	DK98104300
CJ02		KCEA1CAH100T ELECT 10μF M 16V	OA10601620	C631		KCEA1HH2R2T ELECT 2.2μF M 50V	OA22505020
CJ03		KCUS1H102KB CER. CHIP 1000pF ±10% 50V	DK96102300	C632		KCUS1H104ZF CER. CHIP 0.1μF F 50V	DK98104300
CJ04		KCUS1H102KB CER. CHIP 1000pF ±10% 50V	DK96102300	C636		KCUS1H104ZF CER. CHIP 0.1μF F 50V	DK98104300
CJ05		KCUS1H181JC CER. CHIP 180pF ±5% 50V	DD95181300	C638		KCUS1H103KB CER. CHIP 0.01μF ±10% 50V	DK96103300
CJ06		KCUS1H181JC CER. CHIP 180pF ±5% 50V	DD95181300	C639		KCUS1H103KB CER. CHIP 0.01μF ±10% 50V	DK96103300
CJ07		KCUS1H153KB CER. CHIP 0.015μF ±10% 16V	DK96153200	C648		KCUS1H471KB CER. CHIP 470pF ±10%	DK96471300
CJ08		KCUS1H153KB CER. CHIP 0.015μF ±10% 16V	DK96153200	C651		KCUS1H104ZF CER. CHIP 0.1μF F 50V	DK98104300
CJ21		KCEA1CAH100T ELECT 10μF M 16V	OA10601620	C652		KCUS1H104ZF CER. CHIP 0.1μF F 50V	DK98104300
CJ22		KCUS1H102KB CER. CHIP 1000pF ±10% 50V	DK96102300	C653		KCUS1H104ZF CER. CHIP 0.1μF F 50V	DK98104300
CJ23		KCUS1H181JC CER. CHIP 180pF ±5% 50V	DD95181300	C654		KCEA1CH101T ELECT 100μF M 10V	OA10701020
CJ24		KCUS1H153KB CER. CHIP 0.015μF ±10% 16V	DK96153200	C655		KCUS1H104ZF CER. CHIP 0.1μF F 50V	DK98104300
CJ31		KCEA1CAH100T ELECT 10μF M 16V	OA10601620	C658		KCUS1H104ZF CER. CHIP 0.1μF F 50V	DK98104300
CJ32		KCUS1H102KB CER. CHIP 1000pF ±10% 50V	DK96102300	C659		KCUS1H103KB CER. CHIP 0.01μF ±10% 50V	DK96103300
CJ33		KCUS1H181JC CHIP 180pF ±5% 50V	DD95181300	C660		KCUS1H104ZF CER. CHIP 0.1μF F 50V	DK98104300
				C661		KCUS1H104ZF CER. CHIP 0.1μF F 50V	DK98104300
				C662		KCUS1H103KB CER. CHIP 0.01μF ±10% 50V	DK96103300
				C665			
				RE01		PB01-RESISTORS KRJ10DJ102T CHIP 1k Ω ±5% 1/16W	NN05102610
				RE02		KRJ10DJ102T CHIP 1k Ω ±5% 1/16W	NN05102610
				RE03		KRJ10DJ473T CHIP 47k Ω ±5% 1/16W	NN05473610
				RE04		KRJ10DJ473T CHIP 47k Ω ±5% 1/16W	NN05473610
				RE05		KRJ10DJ102T CHIP 1k Ω ±5% 1/16W	NN05102610
				RE06		KRJ10DJ102T CHIP 1k Ω ±5% 1/16W	NN05102610
				RE07		KRJ10DJ473T CHIP 47k Ω ±5% 1/16W	NN05473610
				RE08		KRJ10DJ473T CHIP 47k Ω ±5% 1/16W	NN05473610

NOTE : "nsp" PART IS LISTED FOR REFERENCE ONLY, MARANTZ WILL NOT SUPPLY THESE PARTS.

POS. NO	VERS. COLOR	DESCRIPTION	PART NO. (MJI)	POS. NO	VERS. COLOR	DESCRIPTION	PART NO. (MJI)
RE09		KRJ10DJ102T CHIP 1k Ω ±5% 1/16W	NN05102610	RJ53			
RE10		KRJ10DJ102T CHIP 1k Ω ±5% 1/16W	NN05102610	∫		KRJ10DJ682T CHIP 6.8k Ω ±5% 1/16W	NN05682610
RE11		KRJ10DJ473T CHIP 47k Ω ±5% 1/16W	NN05473610	RJ56			
RE12		KRJ10DJ473T CHIP 47k Ω ±5% 1/16W	NN05473610	RJ58		KRJ10DJ682T CHIP 6.8k Ω ±5% 1/16W	NN05682610
RE15		KRJ10DJ473T CHIP 47k Ω ±5% 1/16W	NN05473610	RJ59			
RE16		KRJ10DJ473T CHIP 47k Ω ±5% 1/16W	NN05473610	∫		KRJ10DJ272T CHIP 2.7k Ω ±5% 1/16W	NN05272610
RE17		KRJ10DJ102T CHIP 1k Ω ±5% 1/16W	NN05102610	RJ62			
RE18		KRJ10DJ102T CHIP 1k Ω ±5% 1/16W	NN05102610	RJ63		KRJ10DJ103T CHIP 10k Ω ±5% 1/16W	NN05103610
RE19				RJ64		KRJ10DJ103T CHIP 10k Ω ±5% 1/16W	NN05103610
∫		KRJ10DJ104T CHIP 100k Ω ±5% 1/16W	NN05104610	RJ65		KRJ10DJ103T CHIP 10k Ω ±5% 1/16W	NN05103610
RE23							
RE31		KRJ10DJ473T CHIP 47k Ω ±5% 1/16W	NN05473610	RK01		KRJ10DJ473T CHIP 47k Ω ±5% 1/16W	NN05473610
RE32		KRJ10DJ473T CHIP 47k Ω ±5% 1/16W	NN05473610	RK02		KRJ10DJ0R0T CHIP 0 Ω ±5% 1/16W	NN05000610
RE33							
∫		KRJ10DJ103T CHIP 10k Ω ±5% 1/16W	NN05103610	R600		KRJ10DJ103T CHIP 10k Ω ±5% 1/16W	NN05103610
RE38				R601		KRJ10DJ473T CHIP 47k Ω ±5% 1/16W	NN05473610
RE39				R602		KRJ10DJ103T CHIP 10k Ω ±5% 1/16W	NN05103610
∫		KRJ10DJ471T CHIP 470 Ω ±5% 1/16W	NN05471610	R603		KRJ10DJ822T CHIP 8.2k Ω ±5% 1/16W	NN05822610
RE42				R604		KRJ10DJ472T CHIP 4.7k Ω ±5% 1/16W	NN05472610
RE57		KRJ10DJ0R0T CHIP 0 Ω ±5% 1/16W	NN05000610	R605		KRJ10DJ472T CHIP 4.7k Ω ±5% 1/16W	NN05472610
RE58		KRJ10DJ0R0T CHIP 0 Ω ±5% 1/16W	NN05000610	R606		KRJ10DJ680T CHIP 68 Ω ±5% 1/16W	NN05680610
				R607		KRJ10DJ682T CHIP 6.8k Ω ±5% 1/16W	NN05682610
RG01		KRJ10DJ222T CHIP 2.2k Ω ±5% 1/16W	NN05222610	R608		KRJ10DJ103T CHIP 10k Ω ±5% 1/16W	NN05103610
RG02		KRJ10DJ222T CHIP 2.2k Ω ±5% 1/16W	NN05222610	R609		KRJ10DJ103T CHIP 10k Ω ±5% 1/16W	NN05103610
RG03		KRJ10DJ222T CHIP 2.2k Ω ±5% 1/16W	NN05222610	R610		KRJ10DJ472T CHIP 4.7k Ω ±5% 1/16W	NN05472610
RG05		KRJ10DJ472T CHIP 4.7k Ω ±5% 1/16W	NN05472610	R611		KRJ10DJ153T CHIP 15k Ω ±5% 1/16W	NN05153610
RG06		KRJ10DJ472T CHIP 4.7k Ω ±5% 1/16W	NN05472610	R612		KRJ10DJ470T CHIP 47 Ω ±5% 1/16W	NN05470610
RG07		KRJ10DJ103T CHIP 10k Ω ±5% 1/16W	NN05103610	R613		KRJ10DJ103T CHIP 10k Ω ±5% 1/16W	NN05103610
RG08		KRJ10DJ103T CHIP 10k Ω ±5% 1/16W	NN05103610	R614		KRJ10DJ472T CHIP 4.7k Ω ±5% 1/16W	NN05472610
RG09		KRJ10DJ102T CHIP 1k Ω ±5% 1/16W	NN05102610	R619		KRJ10DJ470T CHIP 47 Ω ±5% 1/16W	NN05470610
RG10		KRJ10DJ102T CHIP 1k Ω ±5% 1/16W	NN05102610	R620			
RG15		KRJ10DJ472T CHIP 4.7k Ω ±5% 1/16W	NN05472610	∫		KRJ10DJ101T CHIP 100 Ω ±5% 1/16W	NN05101610
RG16		KRJ10DJ472T CHIP 4.7k Ω ±5% 1/16W	NN05472610	R624			
RG17		KRJ10DJ103T CHIP 10k Ω ±5% 1/16W	NN05103610	R625		KRJ10DJ473T CHIP 47k Ω ±5% 1/16W	NN05473610
RG18		KRJ10DJ103T CHIP 10k Ω ±5% 1/16W	NN05103610	R626			
RG19		KRJ10DJ102T CHIP 1k Ω ±5% 1/16W	NN05102610	∫		KRJ10DJ105T CHIP 1M Ω ±5% 1/16W	NN05105610
RG20		KRJ10DJ102T CHIP 1k Ω ±5% 1/16W	NN05102610	R629			
RG23		KRJ10DJ472T CHIP 4.7k Ω ±5% 1/16W	NN05472610	R630		KRJ10DJ101T CHIP 100 Ω ±5% 1/16W	NN05101610
RG24		KRJ10DJ103T CHIP 10k Ω ±5% 1/16W	NN05103610	R631		KRJ10DJ101T CHIP 100 Ω ±5% 1/16W	NN05101610
RG25		KRJ10DJ102T CHIP 1k Ω ±5% 1/16W	NN05102610	R632		KRJ10DJ103T CHIP 10k Ω ±5% 1/16W	NN05103610
RG27		KRJ10DJ472T CHIP 4.7k Ω ±5% 1/16W	NN05472610	R633			
RG28		KRJ10DJ153T CHIP 15k Ω ±5% 1/16W	NN05153610	∫		KRJ10DJ101T CHIP 100 Ω ±5% 1/16W	NN05101610
RG29		KRJ10DJ102T CHIP 1k Ω ±5% 1/16W	NN05102610	R636			
				R637		KRJ10DJ103T CHIP 10k Ω ±5% 1/16W	NN05103610
RJ01				R638		KRJ10DJ103T CHIP 10k Ω ±5% 1/16W	NN05103610
∫		KRJ10DJ103T CHIP 10k Ω ±5% 1/16W	NN05103610	R639		KRJ10DJ101T CHIP 100 Ω ±5% 1/16W	NN05101610
RJ06				R640		KRJ10DJ101T CHIP 100 Ω ±5% 1/16W	NN05101610
RJ07				R641		KRJ10DJ103T CHIP 10k Ω ±5% 1/16W	NN05103610
∫		KRJ10DJ102T CHIP 1k Ω ±5% 1/16W	NN05102610	R643		KRJ10DJ273T CHIP 27k Ω ±5% 1/16W	NN05273610
RJ10				R644		KRJ10DJ0R0T CHIP 0 Ω ±5% 1/16W	NN05000610
RJ11		KRJ10DJ222T CHIP 2.2k Ω ±5% 1/16W	NN05222610	R645		KRJ10DJ473T CHIP 47k Ω ±5% 1/16W	NN05473610
RJ12		KRJ10DJ222T CHIP 2.2k Ω ±5% 1/16W	NN05222610	R646		KRJ10DJ470T CHIP 47 Ω ±5% 1/16W	NN05470610
RJ13		KRJ10DJ104T CHIP 100k Ω ±5% 1/16W	NN05104610	R647		KRJ10DJ472T CHIP 4.7k Ω ±5% 1/16W	NN05472610
RJ21		KRJ10DJ103T CHIP 10k Ω ±5% 1/16W	NN05103610	R648		KRJ10DJ333T CHIP 33k Ω ±5% 1/16W	NN05333610
RJ22		KRJ10DJ103T CHIP 10k Ω ±5% 1/16W	NN05103610	R649		KRJ10DJ472T CHIP 4.7k Ω ±5% 1/16W	NN05472610
RJ23		KRJ10DJ103T CHIP 10k Ω ±5% 1/16W	NN05103610	R650			
RJ24		KRJ10DJ102T CHIP 1k Ω ±5% 1/16W	NN05102610	∫		KRJ10DJ103T CHIP 10k Ω ±5% 1/16W	NN05103610
RJ25		KRJ10DJ102T CHIP 1k Ω ±5% 1/16W	NN05102610	R654			
RJ26		KRJ10DJ222T CHIP 2.2k Ω ±5% 1/16W	NN05222610	R655		KRJ10DJ684T CHIP 680k Ω ±5% 1/16W	NN05684610
RJ31		KRJ10DJ103T CHIP 10k Ω ±5% 1/16W	NN05103610	R656		KRJ10DJ103T CHIP 10k Ω ±5% 1/16W	NN05103610
RJ32		KRJ10DJ103T CHIP 10k Ω ±5% 1/16W	NN05103610	R657		KRJ10DJ472T CHIP 4.7k Ω ±5% 1/16W	NN05472610
RJ33		KRJ10DJ333T CHIP 33k Ω ±5% 1/16W	NN05333610	R658		KRJ10DJ472T CHIP 4.7k Ω ±5% 1/16W	NN05472610
RJ41				R659		KRJ10DJ103T CHIP 10k Ω ±5% 1/16W	NN05103610
∫		KRJ10DJ103T CHIP 10k Ω ±5% 1/16W	NN05103610	R660			
RJ46				∫		KRJ10DJ473T CHIP 47k Ω ±5% 1/16W	NN05473610
RJ51		KRJ10DJ472T CHIP 4.7k Ω ±5% 1/16W	NN05472610	R663			
RJ52		KRJ10DJ472T CHIP 4.7k Ω ±5% 1/16W	NN05472610	R664		KRJ10DJ472T CHIP 4.7k Ω ±5% 1/16W	NN05472610
				R665		KRJ10DJ103T CHIP 10k Ω ±5% 1/16W	NN05103610
				R666		KRJ10DJ103T CHIP 10k Ω ±5% 1/16W	NN05103610

NOTE : "nsp" PART IS LISTED FOR REFERENCE ONLY, MARANTZ WILL NOT SUPPLY THESE PARTS.

POS. NO	VERS. COLOR	DESCRIPTION	PART NO. (MJ)	POS. NO	VERS. COLOR	DESCRIPTION	PART NO. (MJ)
R667		KRJ10DJ103T CHIP 10k Ω ±5% 1/16W	NN05103610	Q610		BVTDTC114EUA TRS. CHIP DTC114EU	BA20035210
R668		KRJ10DJ682T CHIP 6.8k Ω ±5% 1/16W	NN05682610	Q611		BVITC74VHC08F IC QUAD AND GATE(2 IN) TC74VHC08F	HC10452050
R669		KRJ10DJ101T CHIP 100 Ω ±5% 1/16W	NN05101610	Q612		BVITC74VHCT125A IC QUAD BUS BUFFER TC74VHCT125AF	HC712505Q0
R670		KRJ10DJ103T CHIP 10k Ω ±5% 1/16W	NN05103610	Q613		BVITC74VHCT574A IC OCTAL D FLIP-FLO TC74VHCT574AF	HC008505K0
R671				Q614		BVITC74VHCT574A IC OCTAL D FLIP-FLO TC74VHCT574AF	HC008505K0
R678		KRJ10DJ470T CHIP 47 Ω ±5% 1/16W	NN05470610	Q615		BVITC74LCX245F IC OCTAL BUS TRANSCEIVER TC74LCX245F	HC008605K0
R679		KRJ10DJ0R0T CHIP 0 Ω ±5% 1/16W	NN05000610	Q616		BVVIS61C1024J IC SRAM (1M) 8X128K 15OR20 NS SOJ	HC10088000
R680		KRJ10DJ682T CHIP 6.8k Ω ±5% 1/16W	NN05682610	Q617		IC O.T.P EPROM AT27C010-90PC	*HS332WATR
R681				Q618		BVITC74VHC08F IC QUAD AND GATE(2 IN) TC74VHC08F	HC10452050
R688		KRJ10DJ472T CHIP 4.7k Ω ±5% 1/16W	NN05472610	Q620		BVTDTC114EUA TRS. CHIP DTC114EU	BA20035210
R689		KRJ10DJ105T CHIP 1M Ω ±5% 1/16W	NN05105610			PB01-MISCELLANEOUS	
R691		KRJ10DJ101T CHIP 100 Ω ±5% 1/16W	NN05101610	JE01		KJJ4P028Z JACK BOARD JE040060	*YT002280R
R692		KRJ10DJ101T CHIP 100 Ω ±5% 1/16W	NN05101610	JE02		KJJ4P028Z JACK BOARD JE040060	*YT002280R
R693				J602		BJS9L001Z MODULE TOS LINK OPTICAL OUTPUT	YJ15000110
R696		KRJ10DJ103T CHIP 10k Ω ±5% 1/16W	NN05103610	J603		BJSTORX178B MODULE OPTICAL RECEIVER	YJ15000160
R697		KRJ10DJ0R0T CHIP 0 Ω ±5% 1/16W	NN05000610				
R698		KRJ10DJ0R0T CHIP 0 Ω ±5% 1/16W	NN05000610	X601		KOX12288E220TF CRYSTAL 12.288MHz (AT-49)	JX12013260
R699		KRJ10DJ0R0T CHIP 0 Ω ±5% 1/16W	NN05000610	X602		BOXCSTCC8000MG CERAMLOCK CSTCC8.00MG-TC 8.000MHz	FQ08004070
		PB01-SEMICONDUCTORS				PC01-VIDEO CIRCUIT BOARD	
DE01		BVD1SS301 DIODE CHIP KDS121 or 1SS301	HZ21005000			PC01-CAPACITORS	
DE02		BVD1SS301 DIODE CHIP KDS121 or 1SS301	HZ21005000	C201		KCUS1H060DC CER. CHIP 6pF ±0.5pF 50V	DD91060300
DE03		BVD1SS300 DIODE CHIP KDS120 or 1SS300	HZ21006000	C202		KCUS1H060DC CER. CHIP 6pF ±0.5pF 50V	DD91060300
DE04		BVD1SS300 DIODE CHIP KDS120 or 1SS300	HZ21006000	C203		KCUS1H180JC CER. CHIP 18pF ±5% 50V	DD95180300
DE05		BVD1SS301 DIODE CHIP KDS121 or 1SS301	HZ21005000	C204		KCUS1H104ZF CER. CHIP 0.1μF F 50V	DK98104300
QE01		BVINJM2068M IC OP AMP NJM2068M	HC10102090	C205		KCEA1CH101T ELECT 100μF M 16V	OA10701620
QE02		BV174HC4052D IC 74HC4052	HC70520020	C206		KCEA1EH470T ELECT 47μF M 10V	OA47601020
QE03		BV174HC4052D IC 74HC4052	HC70520020	C207		KCUS1H060DC CER. CHIP 6pF ±0.5pF 50V	DD91060300
QE05		BVINJM2068M IC OP AMP NJM2068M	HC10102090	C208		KCUS1H060DC CER. CHIP 6pF ±0.5pF 50V	DD91060300
QE06		BVINJM2068M IC OP AMP NJM2068M	HC10102090	C209		KCUS1H180JC CER. CHIP 18pF ±5% 50V	DD95180300
QE07		BVTDTA114YUA TRS. CHIP DTA114YU	BA12307000	C210		KCUS1H104ZF CER. CHIP 0.1μF F 50V	DK98104300
QG01		BVITC9482F IC ELECT VOL TC9482F	*HC106890R	C211		KCUS1H104ZF CER. CHIP 0.1μF F 50V	DK98104300
QG02		BVINJM2082M IC OP AMP NJM2082M	HC10103090	C212		KCUS1H060DC CER. CHIP 6pF ±0.5pF 50V	DD91060300
QG03		BVINJM2082M IC OP AMP NJM2082M	HC10103090	C213		KCUS1H060DC CER. CHIP 6pF ±0.5pF 50V	DD91060300
QG04		BVINJM2082M IC OP AMP NJM2082M	HC10103090	C214		KCUS1H180JC CER. CHIP 18pF ±5% 50V	DD95180300
QJ01		BVINJM2068M IC OP AMP NJM2068M	HC10102090	C215		KCUS1H104ZF CER. CHIP 0.1μF F 50V	DK98104300
QJ02		BVINJM2068M IC OP AMP NJM2068M	HC10102090	C216		KCEA1EH470T ELECT 47μF M 10V	OA47601020
QJ03		BVINJM2068M IC OP AMP NJM2068M	HC10102090	C229		KCUS1H103KB CER. CHIP 0.01μF ±10% 50V	DK96103300
QJ04		BVINJM2068M IC OP AMP NJM2068M	HC10102090	C230		KCUS1H470JC CER. CHIP 47pF ±5% 50V	DD95470300
QJ05		BVT2SC4213B TRS. CHIP 2SC4213	HX342132A0				
QJ06		BVT2SC4213B TRS. CHIP 2SC4213	HX342132A0	C231		KCEA1AH471T ELECT 470μF M 10V	OA47701020
QJ07		BVINJM2068M IC OP AMP NJM2068M	HC10102090	C232		KCUS1H103KB CER. CHIP 0.01μF ±10% 50V	DK96103300
QJ08		BVT2SC4213B TRS. CHIP 2SC4213	HX342132A0	C233		KCUS1H103KB CER. CHIP 0.01μF ±10% 50V	DK96103300
QJ09		BVTDTA114YUA TRS. CHIP DTA114YU	BA12307000	C234		KCEA1CH101T ELECT 100μF M 16V	OA10701620
QJ51		BVINJM2068M IC OP AMP NJM2068M	HC10102090	C235		KCUS1H101JC CER. CHIP 100pF ±5% 50V	DD95101300
QK01		BVIAK4527VQ IC CODEC AK4527	*HC106900R	C236		KCUS1H101JC CER. CHIP 100pF ±5% 50V	DD95101300
Q601		BVILC89055WRA8 IC DIR LC89055W-RA8	HC10405030	C238		KCEA1CH101T ELECT 100μF M 16V	OA10701620
Q602		BVITC74HCT08AF IC QUAD AND GATE(2 IN) TC74HCT08AF	HC700805Q0	C239		KCUS1H103KB CER. CHIP 0.01μF ±10% 50V	DK96103300
Q603		BVITC74VHC08F IC QUAD AND GATE(2 IN) TC74VHC08F	HC10452050	C240		KCEA1CH101T ELECT 100μF M 16V	OA10701620
Q604		BVIS80745AND9 DETECTOR CHIP VOLTAGE S-80745AN-D9	HC10048530	C241		KCUS1H103KB CER. CHIP 0.01μF ±10% 50V	DK96103300
Q605		IC FLASH MB90F553APF	*HS332WF0R	C244		KCUS1H103KB CER. CHIP 0.01μF ±10% 50V	DK96103300
Q606		BVICSI24W04J IC EEPROM AT24C04N-10SI-2.5	HC10033990	C247		KCUS1H103KB CER. CHIP 0.01μF ±10% 50V	DK96103300
Q609		BVICS493292 IC DSP CS493292	HC10009880	C257		KCUS1H103KB CER. CHIP 0.01μF ±10% 50V	DK96103300
				C258		KCUS1H103KB CER. CHIP 0.01μF ±10% 50V	DK96103300
				C259		KCUS1H103KB CER. CHIP 0.01μF ±10% 50V	DK96103300
				C260		KCEA1HH1R0T ELECT 1μF 50V	OA10505020
				C262		KCUS1H103KB CER. CHIP 0.01μF ±10% 50V	DK96103300

NOTE : *nsp* PART IS LISTED FOR REFERENCE ONLY, MARANTZ WILL NOT SUPPLY THESE PARTS.

POS. NO	VERS. COLOR	DESCRIPTION	PART NO. (MJI)	POS. NO	VERS. COLOR	DESCRIPTION	PART NO. (MJI)
C263		KCEA1HH1R0T ELECT 1μF 50V	OA10505020	R275		KRJ10DJ750T CHIP 75 Ω ±5% 1/16W	NN05750610
C265		KCUS1H103KB CER. CHIP 0.01μF ±10% 50V	DK96103300	R276		KRJ10DJ101T CHIP 100 Ω ±5% 1/16W	NN05101610
C266		KCEA1HH1R0T ELECT 1μF 50V	OA10505020	R277		KRJ10DJ750T CHIP 75 Ω ±5% 1/16W	NN05750610
C268		KCUS1H103KB CER. CHIP 0.01μF ±10% 50V	DK96103300	R280		KRJ10DJ101T CHIP 100 Ω ±5% 1/16W	NN05101610
C270		KCEA1AH471T ELECT 470μF M 10V	OA47701020	R281		KRJ10DJ750T CHIP 75 Ω ±5% 1/16W	NN05750610
C271		KCUS1H103KB CER. CHIP 0.01μF ±10% 50V	DK96103300	R282		KRJ10DJ101T CHIP 100 Ω ±5% 1/16W	NN05101610
C272		KCEA1EH470T ELECT 47μF M 10V	OA47601020	R283		KRJ10DJ750T CHIP 75 Ω ±5% 1/16W	NN05750610
C273		KCEA1HH1R0T ELECT 1μF 50V	OA10505020	R286		KRJ10DJ101T CHIP 100 Ω ±5% 1/16W	NN05101610
C274		KCEA1AH471T ELECT 470μF M 10V	OA47701020	R287		KRJ10DJ750T CHIP 75 Ω ±5% 1/16W	NN05750610
C275		KCEA1AH471T ELECT 470μF M 10V	OA47701020	R288		KRJ10DJ682T CHIP 6.8k Ω ±5% 1/16W	NN05682610
C276		KCUS1H103KB CER. CHIP 0.01μF ±10% 50V	DK96103300	R289		KRJ10DJ103T CHIP 10k Ω ±5% 1/16W	NN05103610
C277		KCEA1EH470T ELECT 47μF M 10V	OA47601020	R290			
C278		KCEA1HH1R0T ELECT 1μF 50V	OA10505020			KRJ10DJ750T CHIP 75 Ω ±5% 1/16W	NN05750610
C279		KCEA1AH471T ELECT 470μF M 10V	OA47701020	R293			
C280		KCUS1H104ZF CER. CHIP 0.1μF F 50V	DK98104300	R294		KRJ10DJ104T CHIP 100k Ω ±5% 1/16W	NN05104610
C281		KCUS1H103KB CER. CHIP 0.01μF ±10% 50V	DK96103300	R295		KRJ10DJ750T CHIP 75 Ω ±5% 1/16W	NN05750610
C282		KCEA1EH470T ELECT 47μF M 10V	OA47601020	R296		KRJ10DJ750T CHIP 75 Ω ±5% 1/16W	NN05750610
C283		KCEA1HH1R0T ELECT 1μF 50V	OA10505020	R297		KRJ10DJ103T CHIP 10k Ω ±5% 1/16W	NN05103610
C284		KCUS1H104ZF CER. CHIP 0.1μF F 50V	DK98104300	R298		KRJ10DJ682T CHIP 6.8k Ω ±5% 1/16W	NN05682610
C287		KCUS1H104ZF CER. CHIP 0.1μF F 50V	DK98104300	R299		KRJ10DJ103T CHIP 10k Ω ±5% 1/16W	NN05103610
C289		KCEA1CH101T ELECT 100μF M 16V	OA10701620				
C290		KCEA1CH101T ELECT 100μF M 16V	OA10701620				
C291		KCEA1CH101T ELECT 100μF M 16V	OA10701620	Q201		BVT2SA1576AQ TRS. CHIP 2SA1576(FQ)	HX115761A0
C293		KCUS1H104ZF CER. CHIP 0.1μF F 50V	DK98104300	Q202		BVT2SA1576AQ TRS. CHIP 2SA1576(FQ)	HX115761A0
C297		KCUS1H104ZF CER. CHIP 0.1μF F 50V	DK98104300	Q203		BVT2SA1576AQ TRS. CHIP 2SA1576(FQ)	HX115761A0
		PC01-CAPACITORS(COMMON)		Q207		BVTDTC114EUA TRS. CHIP DTC114EU	BA20035210
		PLASTIC FILM CAPACITOR		Q209		BVTDTC114EUA TRS. CHIP DTC114EU	BA20035210
		±5% 50V : C261 C264 C267		Q210		BVILA7138M IC VIDEO AMP LA7138M	HC10406030
				Q211		BVT2SB1237R TRS. 2SB1237 (R)	HT212371C0
		PC01-RESISTORS		Q214		BVT2SA1576AQ TRS. CHIP 2SA1576(FQ)	HX115761A0
R201		KRJ10DJ821T CHIP 820 Ω ±5% 1/16W	NN05821610	Q215		BVT2SC4081R TRS. CHIP 2SC4081 (BR)	HX340811B0
R202		KRJ10DJ101T CHIP 100 Ω ±5% 1/16W	NN05101610	Q216		BVT2SA1576AQ TRS. CHIP 2SA1576(FQ)	HX115761A0
R204		KRJ10DJ222T CHIP 2.2k Ω ±5% 1/16W	NN05222610	Q217		BVT2SC4081R TRS. CHIP 2SC4081 (BR)	HX340811B0
R205		KRJ10DJ821T CHIP 820 Ω ±5% 1/16W	NN05821610	Q218		BVT2SA1576AQ TRS. CHIP 2SA1576(FQ)	HX115761A0
R206		KRJ10DJ101T CHIP 100 Ω ±5% 1/16W	NN05101610	Q219		BVT2SC4081R TRS. CHIP 2SC4081 (BR)	HX340811B0
R208		KRJ10DJ222T CHIP 2.2k Ω ±5% 1/16W	NN05222610	Q230		BVIBA7625 IC VIDEO SW BA7625	HC10189210
R209		KRJ10DJ821T CHIP 820 Ω ±5% 1/16W	NN05821610	Q231		BVIBA7625 IC VIDEO SW BA7625	HC10189210
R210		KRJ10DJ101T CHIP 100 Ω ±5% 1/16W	NN05101610	Q232		BVIBA7626F IC VIDEO SW BA7626F	*HC106910R
R212		KRJ10DJ222T CHIP 2.2k Ω ±5% 1/16W	NN05222610	Q233		BVT2SA1576AQ TRS. CHIP 2SA1576(FQ)	HX115761A0
R213		KRJ10DJ821T CHIP 820 Ω ±5% 1/16W	NN05821610	Q235		BVT2SA1576AQ TRS. CHIP 2SA1576(FQ)	HX115761A0
R214		KRJ10DJ0R0T CHIP 0 Ω ±5% 1/16W	NN05000610	Q236		BVT2SA1576AQ TRS. CHIP 2SA1576(FQ)	HX115761A0
R215		KRJ10DJ0R0T CHIP 0 Ω ±5% 1/16W	NN05000610	Q238		BVT2SA1576AQ TRS. CHIP 2SA1576(FQ)	HX115761A0
R225		KRJ10DJ103T CHIP 10k Ω ±5% 1/16W	NN05103610	Q239		BVT2SA1576AQ TRS. CHIP 2SA1576(FQ)	HX115761A0
R226		KRJ10DJ332T CHIP 3.3k Ω ±5% 1/16W	NN05332610	Q241		BVT2SA1576AQ TRS. CHIP 2SA1576(FQ)	HX115761A0
R231		KRJ10DJ0R0T CHIP 0 Ω ±5% 1/16W	NN05000610	Q242		BVTDTC114EUA TRS. CHIP DTC114EU	BA20035210
R232		KRJ10DJ822T CHIP 8.2k Ω ±5% 1/16W	NN05822610	Q243		BVT2SB1237R TRS. 2SB1237 (R)	HT212371C0
R233		KRJ10DJ0R0T CHIP 0 Ω ±5% 1/16W	NN05000610	Q245		BVI74HC4066D IC SWITCHING 74HC4066 AF	HC706600Z0
R234		KRJ10DJ0R0T CHIP 0 Ω ±5% 1/16W	NN05000610	J204		KJJ9N001Z JACK S-VIDEO (2P/H) 2P S TERMINAL	*YT002320R
R235		KRJ10DJ0R0T CHIP 0 Ω ±5% 1/16W	NN05000610	J205		KJJ9N001Z JACK S-VIDEO (2P/H) 2P S TERMINAL	*YT002320R
R237		KRJ10DJ103T CHIP 10k Ω ±5% 1/16W	NN05103610	J207		KJJ4N051Z JACK IN/OUT(2P YEL) JE0201635N	*YT002330R
R238		KRJ10DJ221T CHIP 220 Ω ±5% 1/16W	NN05221610	J208		KJJ4N051Z JACK IN/OUT(2P YEL) JE0201635N	*YT002330R
R239		KRJ10DJ102T CHIP 1k Ω ±5% 1/16W	NN05102610	L201		KLQ120J405T COIL PEAKING(RADIAL) EL0405RA-120	LC11233900
R240		KRJ10DJ102T CHIP 1k Ω ±5% 1/16W	NN05102610	L202		KLQ120J405T COIL PEAKING(RADIAL) EL0405RA-120	LC11233900
R241		KRJ10DJ182T CHIP 1.8k Ω ±5% 1/16W	NN05182610	L203		KLQ120J405T COIL PEAKING(RADIAL) EL0405RA-120	LC11233900
R246		KRJ10DJ821T CHIP 820 Ω ±5% 1/16W	NN05821610	L209		BLZ9O001Z BEAD FERRITE(CHIP) BLM41P600S PT	FN31060010
R247		KRJ10DJ102T CHIP 1k Ω ±5% 1/16W	NN05102610	L212		KLQ470J405T COIL PEAKING(RADIAL) EL0405RA-470	LC14733900
R248		KRJ10DJ102T CHIP 1k Ω ±5% 1/16W	NN05102610	L213		KLQ470J405T COIL PEAKING(RADIAL) EL0405RA-470	LC14733900
R249		KRJ10DJ182T CHIP 1.8k Ω ±5% 1/16W	NN05182610				
R254		KRJ10DJ331T CHIP 330 Ω ±5% 1/16W	NN05331610				
R255		KRJ10DJ102T CHIP 1k Ω ±5% 1/16W	NN05102610				
R256		KRJ10DJ102T CHIP 1k Ω ±5% 1/16W	NN05102610				
R257		KRJ10DJ182T CHIP 1.8k Ω ±5% 1/16W	NN05182610				
R263		KRJ10DJ103T CHIP 10k Ω ±5% 1/16W	NN05103610				
R269		KRJ10DJ0R0T CHIP 0 Ω ±5% 1/16W	NN05000610				
R270		KRJ10DJ101T CHIP 100 Ω ±5% 1/16W	NN05101610				
R271		KRJ10DJ750T CHIP 75 Ω ±5% 1/16W	NN05750610				
R274		KRJ10DJ101T CHIP 100 Ω ±5% 1/16W	NN05101610				

NOTE : *nsp* PART IS LISTED FOR REFERENCE ONLY, MARANTZ WILL NOT SUPPLY THESE PARTS.

POS. NO	VERS. COLOR	DESCRIPTION	PART NO. (MJI)	POS. NO	VERS. COLOR	DESCRIPTION	PART NO. (MJI)
L214		KLQ470J405T COIL PEAKING(RADIAL) EL0405RA-470	LC14733900			PF01-MISCELLANEOUS	
L215		BLZ90001Z BEAD FERRITE(CHIP) BLM41P600S PT	FN31060010	SY01 }		BST1A016ZT SW TACT	SP01013310
		PC02-D CONNECTOR CIRCUIT BOARD PC02-CAPACITORS		SY07			
C401		KCEA1AH471T ELECT 470µF M 10V	OA47701020	VY01		KFL12BT123GNK F.I.P FL DISPLAY 12-BT-123GNK	HQ31005410
C402		KCEA1AH471T ELECT 470µF M 10V	OA47701020			PF02-FRONT SWITCH CIRCUIT BOARD PF02-CAPACITOR	
C403		KCEA1AH471T ELECT 470µF M 10V	OA47701020	CY06		KCUS1H104ZF CER. CHIP 0.1µF F 50V	DK98104300
		PC02-RESISTORS				PF02-RESISTORS	
R401		KRJ10DJ3R3T CHIP 3.3 Ω ±5% 1/16W	NN05033610	RY31		KRJ10DJ472T CHIP 4.7k Ω ±5% 1/16W	NN05472610
R402		KRJ10DJ470T CHIP 47 Ω ±5% 1/16W	NN05470610	RY32		KRJ10DJ471T CHIP 470 Ω ±5% 1/16W	NN05471610
R403		KRJ10DJ330T CHIP 33 Ω ±5% 1/16W	NN05330610	RY33		KRJ10DJ681T CHIP 680 Ω ±5% 1/16W	NN05681610
R404		KRJ10DJ470T CHIP 47 Ω ±5% 1/16W	NN05470610	RY34		KRJ10DJ102T CHIP 1k Ω ±5% 1/16W	NN05102610
R405		KRJ10DJ122T CHIP 1.2k Ω ±5% 1/16W	NN05122610	RY35		KRJ10DJ102T CHIP 1k Ω ±5% 1/16W	NN05102610
R407		KRJ10DJ330T CHIP 33 Ω ±5% 1/16W	NN05330610	RY36		KRJ10DJ122T CHIP 1.2k Ω ±5% 1/16W	NN05122610
R408		KRJ10DJ470T CHIP 47 Ω ±5% 1/16W	NN05470610	RY37		KRJ10DJ103T CHIP 10k Ω ±5% 1/16W	NN05103610
R409		KRJ10DJ122T CHIP 1.2k Ω ±5% 1/16W	NN05122610			PF02-SEMICONDUCTOR	
R411		KRJ10DJ0R0T CHIP 0 Ω ±5% 1/16W	NN05000610	QY05		BRVRPM6936V4 SENSOR REMOCON RPM6936-V4 (IR)	HW10004210
		PC02-MISCELLANEOUS				PF02-MISCELLANEOUS	
J402		BJJYKF45-3001 CONNECTOR D TERMINAL YKF45-3001	YJ11000660	SY31 }		BST1A016ZT SW TACT	SP01013310
		PF01-FRONT DISPLAY CIRCUIT BOARD PF01-CAPACITORS		SY36			
CY02		KCUS1H104ZF CER. CHIP 0.1µF F 50V	DK98104300			PF03-VOLUME (ROTARY SW) CIRCUIT BOARD	
CY04		KCUS1H102KB CER. CHIP 1000pF ±10% 50V	DK96102300	SY21		BSR2A017Z VR ENCODER EC16B2410207	SR01240020
CY05		KCUS1H102KB CER. CHIP 1000pF ±10% 50V	DK96102300			PF04-HEADPHONE JACK CIRCUIT BOARD PF04-CAPACITORS	
		PF01-RESISTORS		CY51		KCUS1H102KB CER. CHIP 1000pF ±10% 50V	DK96102300
RY01		KRJ10DJ100T CHIP 10 Ω ±5% 1/16W	NN05100610	CY52		KCUS1H102KB CER. CHIP 1000pF ±10% 50V	DK96102300
RY02		KRJ10DJ563T CHIP 56k Ω ±5% 1/16W	NN05563610			PF04-CAPACITORS(COMMON)	
RY03		KRJ10DJ473T CHIP 47k Ω ±5% 1/16W	NN05473610			HIGH DIELECTRIC CONSTANT CERAMIC CAPACITORS ±10% 50V : CY53 CY54	
RY04		KRJ10DJ473T CHIP 47k Ω ±5% 1/16W	NN05473610	C***			
RY05		KRJ10DJ221T CHIP 220 Ω ±5% 1/16W	NN05221610			PF04-MISCELLANEOUS	
RY11		KRJ10DJ472T CHIP 4.7k Ω ±5% 1/16W	NN05472610	JY52		BJJ2D005Z JACK MINI PHONE TC3B-160-02C	*YJ002340R
RY12		KRJ10DJ471T CHIP 470 Ω ±5% 1/16W	NN05471610			PJ01-JUMPER CIRCUIT BOARD PJ01-CAPACITORS	
RY13		KRJ10DJ681T CHIP 680 Ω ±5% 1/16W	NN05681610	CA01		KCEA1AH471T ELECT 470µF M 10V	OA47701020
RY14		KRJ10DJ102T CHIP 1k Ω ±5% 1/16W	NN05102610	CA02		KCEA1AH471T ELECT 470µF M 10V	OA47701020
RY15		KRJ10DJ102T CHIP 1k Ω ±5% 1/16W	NN05102610			NOT STANDARD SPARE PARTS	
RY16		KRJ10DJ122T CHIP 1.2k Ω ±5% 1/16W	NN05122610	W001		KWC1C4A28B150A FFC (JA01-J607) 28P X 150mm	YU28150500
RY17		KRJ10DJ103T CHIP 10k Ω ±5% 1/16W	NN05103610	W002		KWC1C4A15B150A FFC (JE03-TUNER) 15P X 150mm	YU15150500
RY18 }		KRJ10DJ470T CHIP 47 Ω ±5% 1/16W	NN05470610	W003		KWC1C4A25B060A FFC (J601-J701) 25P X 60mm	YU25060500
RY22				W004		KWC1C4A14B300A FFC (J605-JY02) 14P X 300mm	YU14300500
RY38		KRJ10DJ472T CHIP 4.7k Ω ±5% 1/16W	NN05472610	W005		KWC1C4A08B080A FFC (JY01-J805) 8P X 80mm	YU08080500
RY39		KRJ10DJ472T CHIP 4.7k Ω ±5% 1/16W	NN05472610	W006		KWC1C4A14B100A FFC (JA04-J201) 14P X 100mm	YU14100500
		PF01-SEMICONDUCTORS		W007		KWC1C4A12B060A FFC (J202-J604) 12P X 60mm	YU12060500
DY01 }		BVDTLGE1008A L.E.D CHIP TLGE1008A(T04)	*HI100940R	W008		KWC1C4A12B060A FFC (J203-J401) 12P X 60mm	YU12060500
DY10							
DY11		KVD342VCTB7T089 L.E.D RED SLR-342VC	HI10071210				
QY01		BVIUPD16311GC IC FIP DRIVE µPD16311GC-AB6 FTD	HC10283060				
QY02		BVTDTC114EUA TRS. CHIP DTC114EU	BA20035210				
QY03		BVTDTC114EUA TRS. CHIP DTC114EU	BA20035210				
QY04		BVTDTC114EUA TRS. CHIP DTC114EU	BA20035210				

NOTE : "nsp" PART IS LISTED FOR REFERENCE ONLY, MARANTZ WILL NOT SUPPLY THESE PARTS.

Service Manual

DB-VLD210

DVD Loader for MARANTZ

DVD Player : DV7010

DV7100

DV-18mkll

DV-17

EC1000

ER3000



TABLE OF CONTENTS

SECTION	PAGE
2.DB-VLD 210 (DVD Loader for MARANTZ)	
2.1 EXTERIOR	2-1
2.2 LOADING MECHANISM ASSY	2-2
2.3 TRAVERSE MECHANISM ASSYS	2-3

Please use this service manual with referring to the user guide (D.F.U) without fail.
修理の際は、必ず取り扱い説明書を準備し操作方法を確認の上作業を行ってください。

marantz®

DB-VLD210

2.1 EXTERIOR

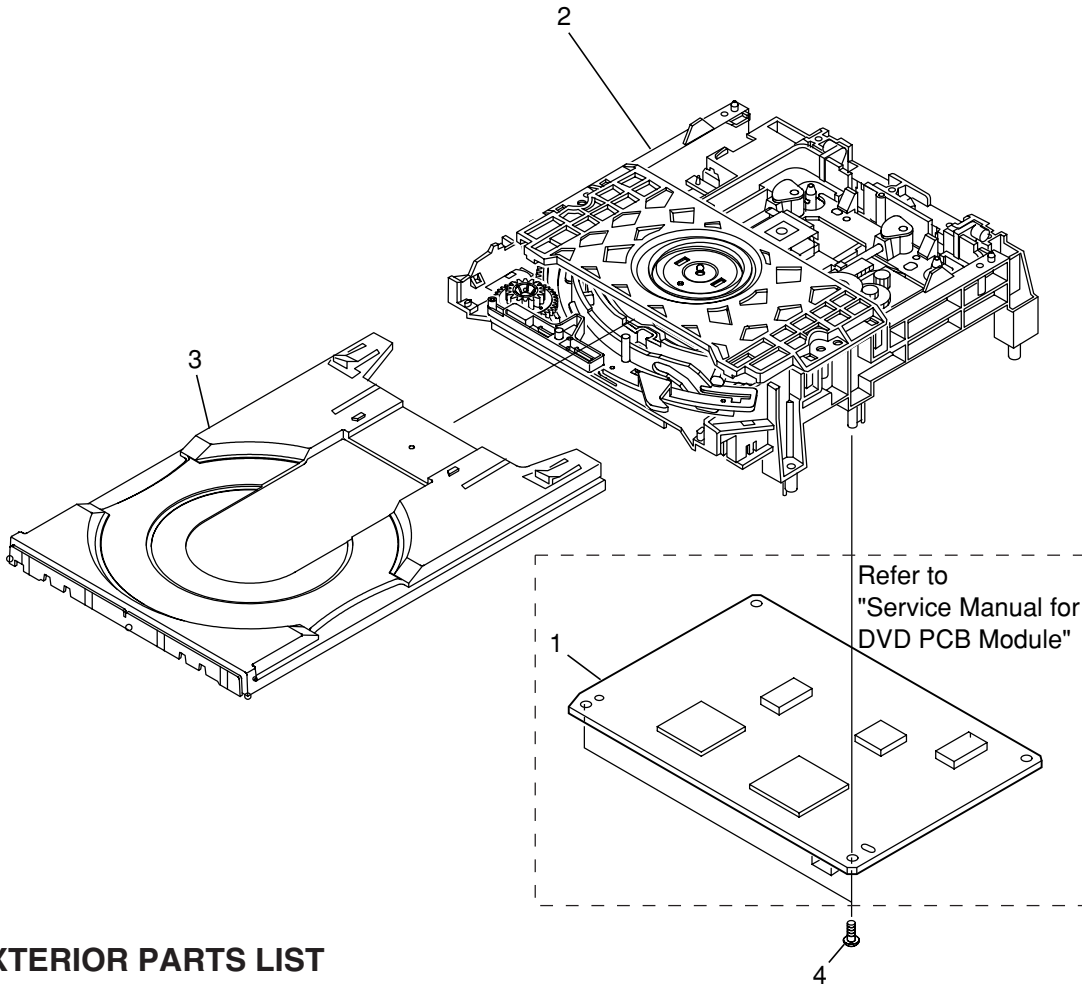

(1) EXTERIOR PARTS LIST

Mark	No.	Part No. (for PCS)	Description	Part No. (for MJ)
	1	—	VWS1446, DVDM Assy DB-VPB210	ZK402K0210
	1	—	VWS1449, DVDM Assy DB-VPB211	ZK324J0210
	1	9965 000 07628	VWS1447, DVDM Assy DB-VPB212	ZK402K0230
	1	—	VWS1448, DVDM Assy DB-VPB213	ZK402K0220
	1	—	VWS1450, DVDM Assy DB-VPB214	ZK324J0220
	1	—	VWS1451, DVDM Assy DB-VPB215	ZK408K0210
NSP	2	—	VWT1174, Loader Assy	—
	3	9965 000 07934	VNL1858, Tray	402K163210
NSP	4	—	PPZ30P080FMC, Screw	—

● DISASSEMBLY OF TRAVERSE MECHANISM ASSY

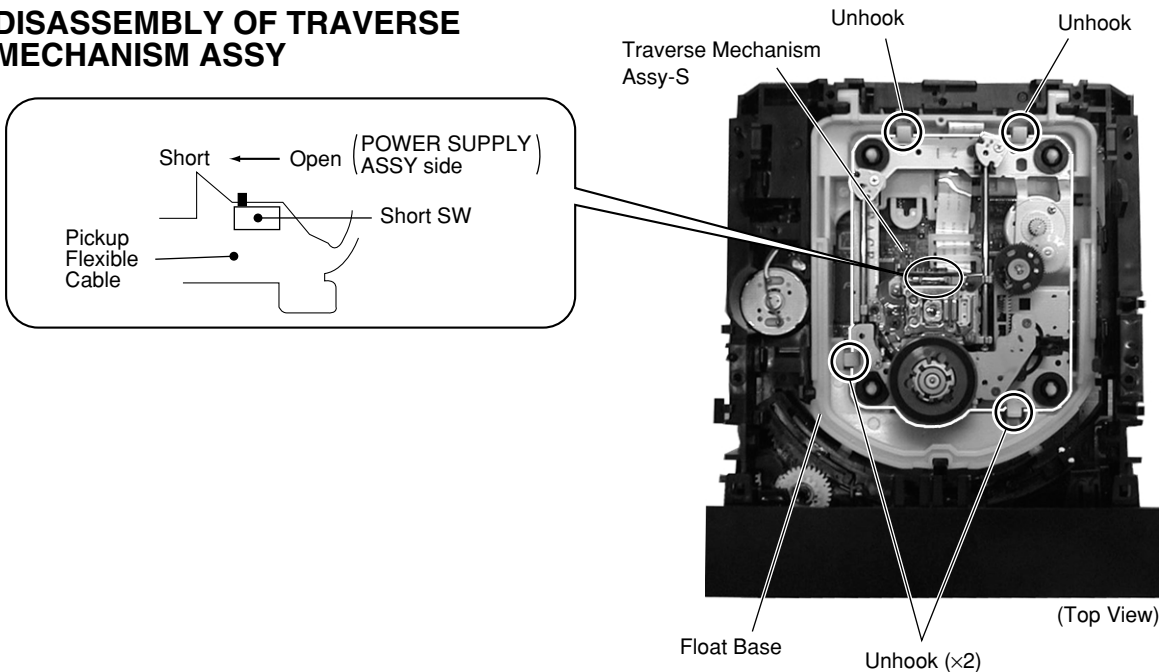

2.2 LOADING MECHANISM ASSY

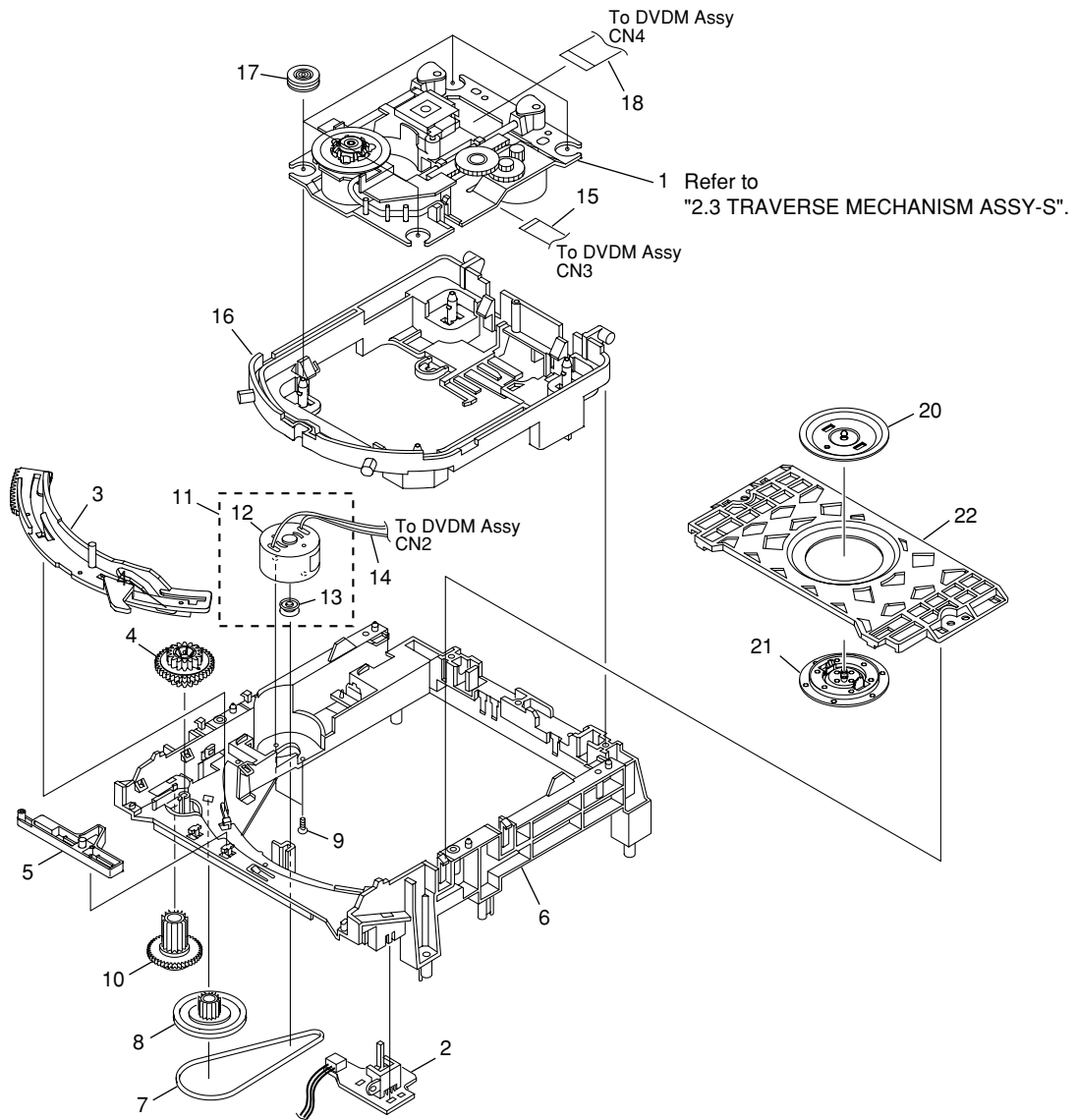

● LOADING MECHANISM ASSY PARTS LIST

Mark	No.	Part No. (for PCS)	Description	Part No. (for MJ)
NSP	1	9965 000 07935	VXX2653, Traverse Mechanism Assy-S	*ZK000310R
	2	—	VWG2171, LOAB Assy	—
	3	9965 000 07936	VNL1862, Drive Cam	402K054210
NSP	4	9965 000 07937	VNL1861, Drive Gear	402K058210
	5	9965 000 07938	VNL1820, Lock Plate	402K104210
	6	—	PNW2968, Loading Bases	—
NSP	7	9965 000 07939	VEB1315, Belt	402K264210
	8	9965 000 07940	VNL1866, Gear Pulley	402K262210
	9	—	JGZ17P028FMC, Screw	—
NSP	10	9965 000 07941	VNL1860, Loading Gear	402K058220
	11	9965 000 07942	VXX2505, Loading Motor Assy	*ZZ001600R

Mark	No.	Part No. (for PCS)	Description	Part No. (for MJ)
NSP	12	—	PXM1027, DC Motor / 0.3W (LOADING)	—
NSP	13	—	PNW1634, Motor Pulley	296W262010
	14	—	VKP2253, Connector Assy	—
NSP	15	9965 000 07943	VDA1842, Flexible Cable (08P)	*YU000790R
	16	9965 000 07944	VNL1865, Float Base	402K105210
	17	9965 000 07945	VEB1286, Floating Rubber	402K056210
	18	9965 000 07946	VDA1843, Flexible Cable (24P)	*YU000800R
	20	9965 000 07947	VNE2162, Clamper Plate	402K104220
	21	9965 000 07948	VNL1738, Clamper	402K005210
	22	9965 000 07949	VNL1859, Bridge	402K104230

2.3 TRAVERSE MECHANISM ASSY-S

• Top View

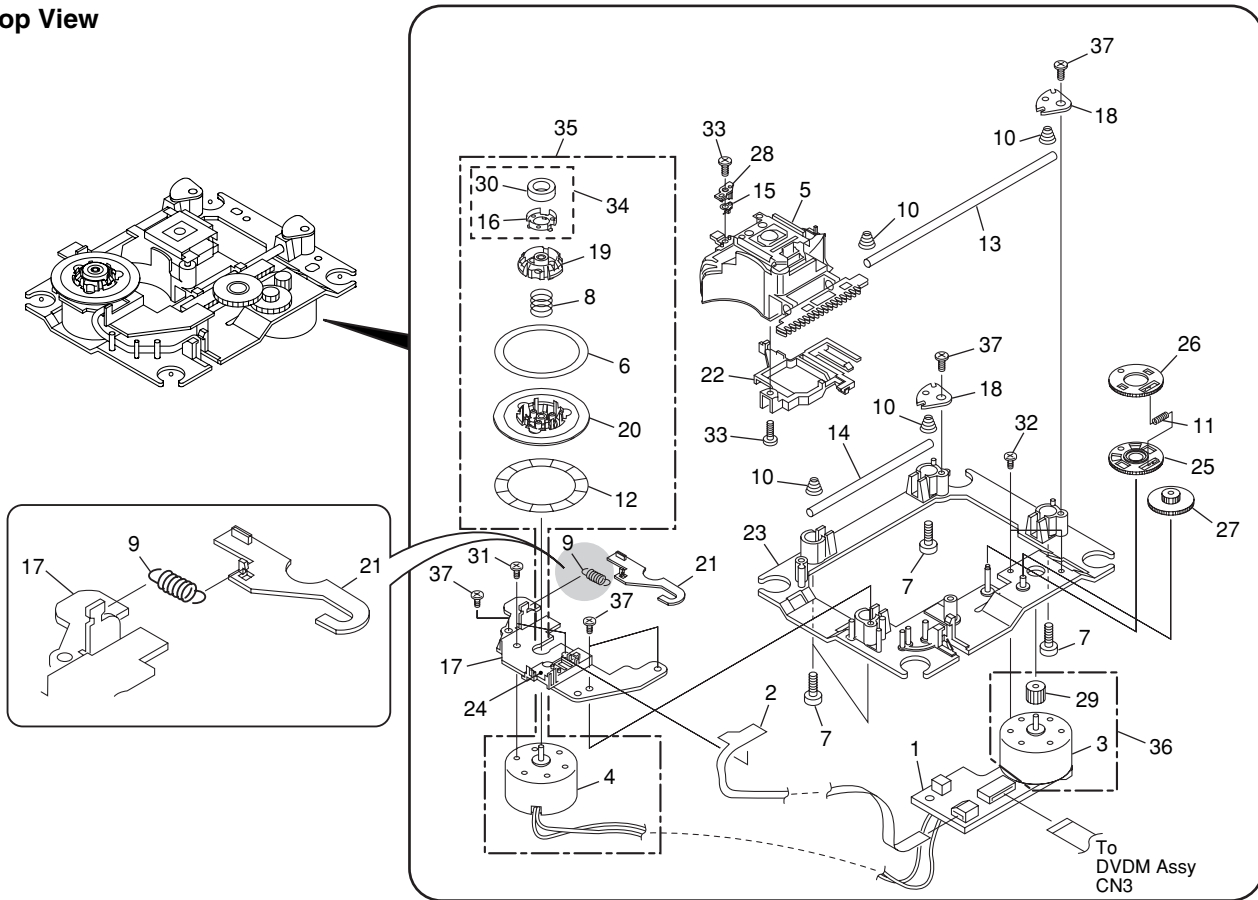

• TRAVERSE MECHANISM ASSY-S PARTS LIST

Mark	No.	Part No. (for PCS)	Description	Part No. (for MJ)
NSP	1	—	VWG2048, SMEB Assy	—
NSP	2	—	VWG2009, FGSB Assy	—
NSP	3	—	VXM1079, Motor	—
NSP	4	—	VXM1084, Motor	—
△NSP	5	—	VWY1055, Pickup Assy	—
NSP	6	—	DEC2040, Table Sheet	—
NSP	7	—	VBA1058, Screw	—
NSP	8	—	VBH1278, Centering Spring	—
	9	9965 000 07950	VBH1317, Hook Spring	296W115050
	10	9965 000 07951	VBH1303, Skew Spring	296W115060
	11	9965 000 07952	VBH1308, Gear Spring	296W115070
NSP	12	—	VEC1959, Reflected Sheet	—
NSP	13	—	VLL1504, Guide Bar	—
NSP	14	—	VLL1505, Sub-guide Bar	—
	15	9965 000 07953	VNC1017, Hold Spring	296W115080
NSP	16	—	VNE2070, Magnet Holder	—
NSP	17	—	VNE2154, Motor Base	—
NSP	18	—	VNE2155, Cover	—
NSP	19	—	VNL1746, Centering Ring	—

Mark	No.	Part No. (for PCS)	Description	Part No. (for MJ)
NSP	20	—	VNL1747, Disc Table	—
	21	9965 000 07954	VNL1770, Hook	296W258010
NSP	22	—	VNL1802, FFC Holder	—
NSP	23	—	VNL1806, Mechanism Base	—
NSP	24	—	VNL1807, FG Holder	—
	25	9965 000 07955	VNL1808, Gear A	296W058090
	26	9965 000 07956	VNL1809, Gear B	296W058100
	27	9965 000 07957	VNL1810, Gear C	296W058110
	28	9965 000 07958	VNL1811, Slider	296W125010
NSP	29	—	VNL1814, Gear D	—
NSP	30	—	VYM1024, Magnet	—
NSP	31	—	JFZ17P025FZK, Screw	—
NSP	32	—	JGZ17P028FMC, Screw	—
NSP	33	—	VBA1051, Screw	—
NSP	34	—	VXX2507, Magnet Holder Assy	—
	35	9965 000 07959	VXX2649, Spindle Motor Assy	*ZK000290R
	36	9965 000 07960	VXX2650, Carriage Motor Assy	*ZK000300R
NSP	37	—	PBA1069, Screw	—

Service Manual

DB-VPB210, DB-VPB211, DB-VPB212, DB-VPB213, DB-VPB214, DB-VPB215 DVD PCB Module for MARANTZ

DVD Player : DV7010
DV7100
DV-18mkII
DV-17
EC1000
ER3000

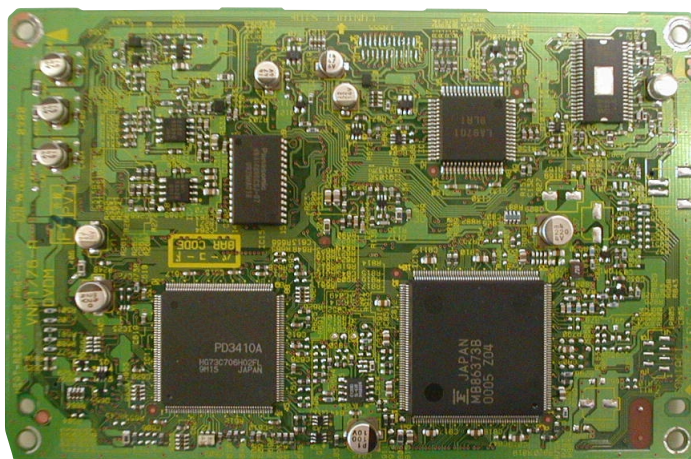

The DVD module is different with each product and version.
Refer to the following table.

Model	Vers.		
	/U, /F, /A	/K, /L, /S, /C	/N
DV7010	DB-VPB210	DB-VPB213	DB-VPB212
DV-18mkII	DB-VPB210	DB-VPB213	
DV-17	DB-VPB210	DB-VPB213	DB-VPB212
DV7100	DB-VPB215		

Model	Vers.		
	/F, /A, /S, /C	/K, /L	/N
EC1000	DB-VPB211	DB-VPB214	
ER3000	DB-VPB211	DB-VPB214	(DB-VPB217)

TABLE OF CONTENTS

SECTION	PAGE
3. DB-VPB210 / 211 / 212 / 213 / 214 / 215 (DVD PCB Module for MARANTZ)	
3.1 BLOCK DIAGRAM AND SCHEMATIC DIAGRAM	3-1
3.2 PCB CONNECTION DIAGRAM	3-10
3.3 PCB PARTS LIST	3-24

Please use this service manual with referring to the user guide (D.F.U) without fail.
修理の際は、必ず取り扱い説明書を準備し操作方法を確認の上作業を行ってください。

marantz®

DB-VPB210/211/212/213/214/215

3.1 BLOCK DIAGRAM AND SCHEMATIC DIAGRAM

3.1.1 BLOCK DIAGRAM

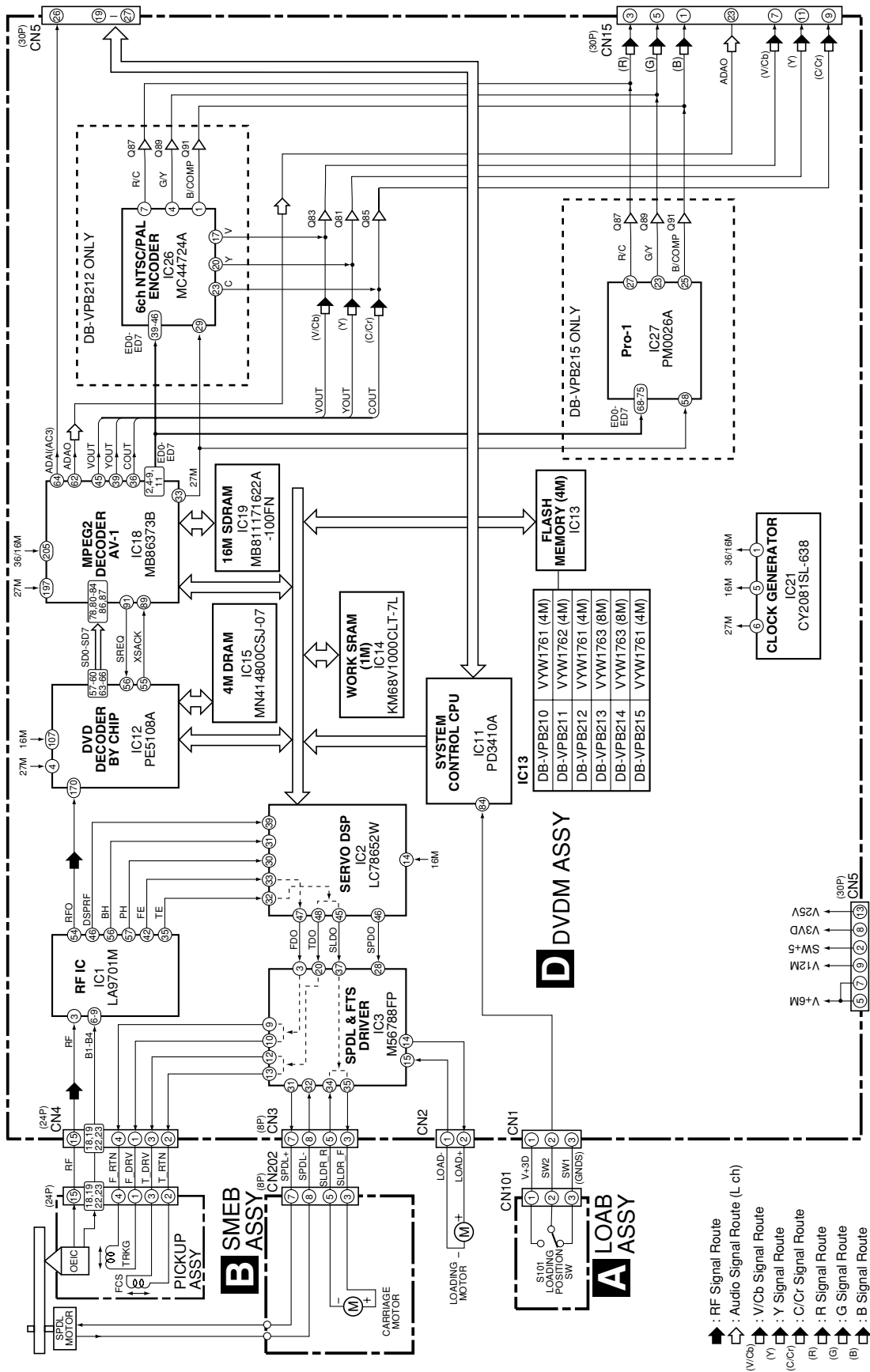

3.1.2 LOAB, SMEB, FGSB ASSYS and OVERALL WIRING DIAGRAM

- ➡ : RF SIGNAL ROUTE
- (F) : FOCUS SERVO LOOP LINE
- (T) : TRACKING SERVO LOOP LINE
- (S) : SLIDER SERVO LOOP LINE

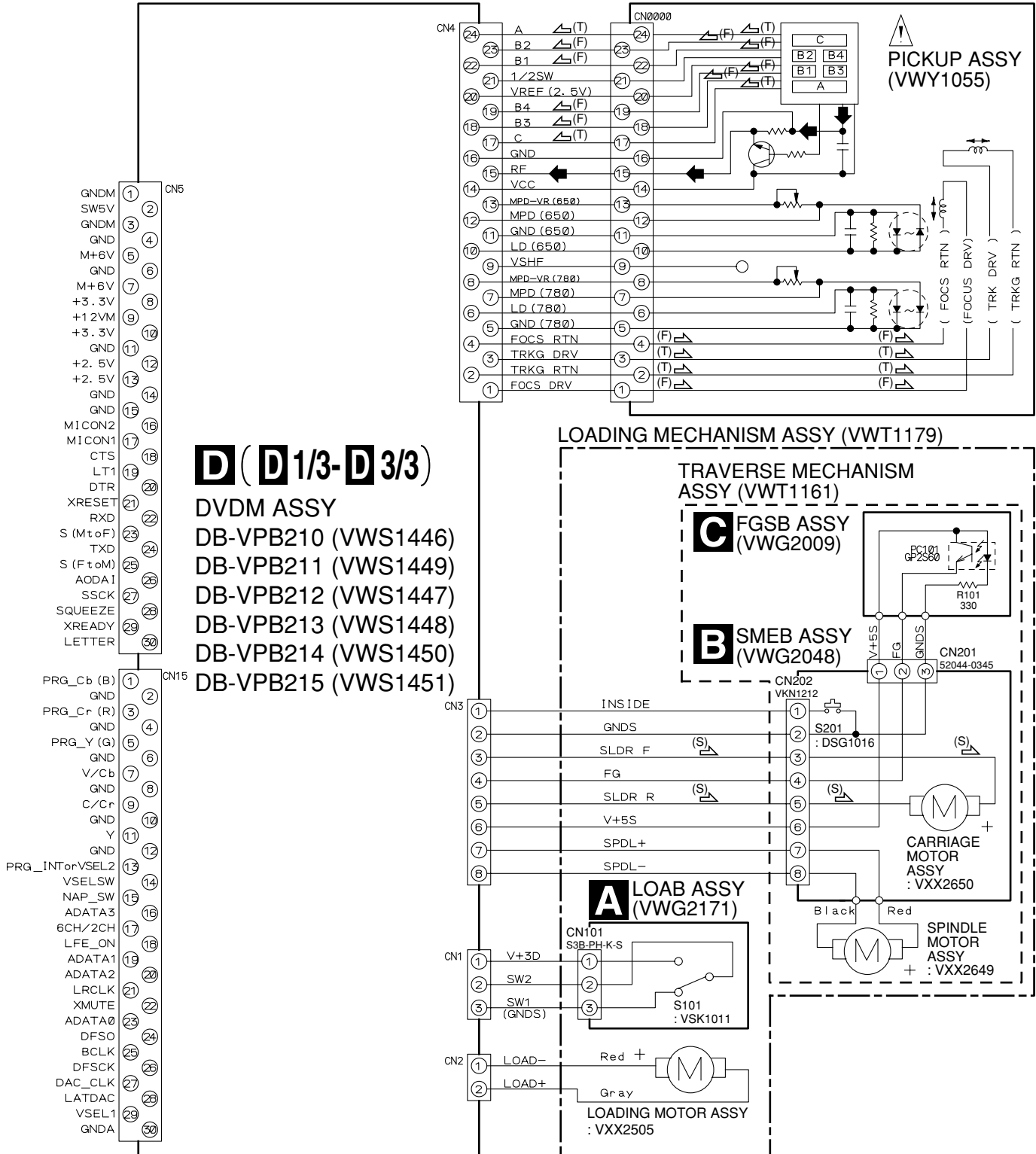

3.1.3 DVDM ASSY (1/3)

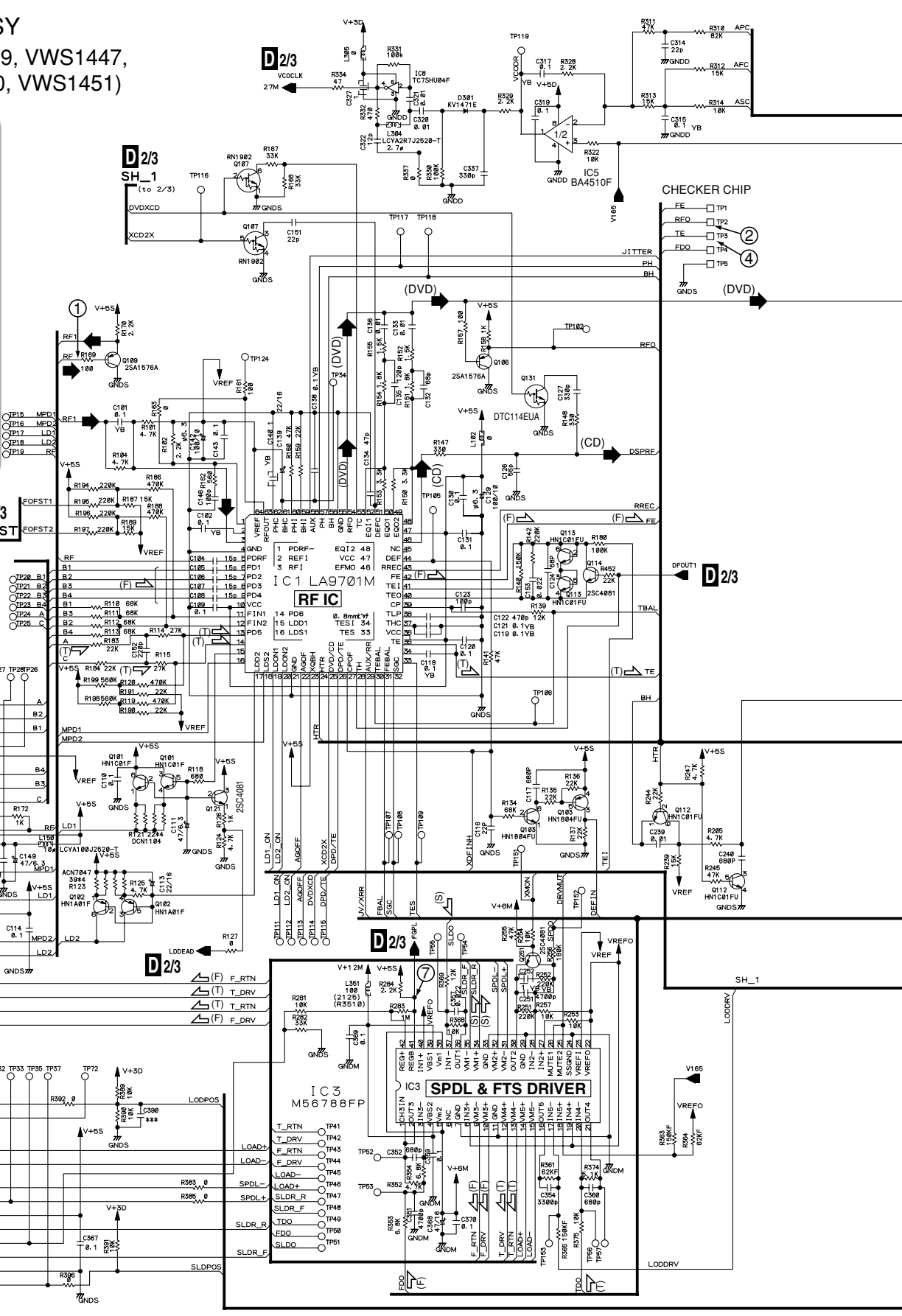
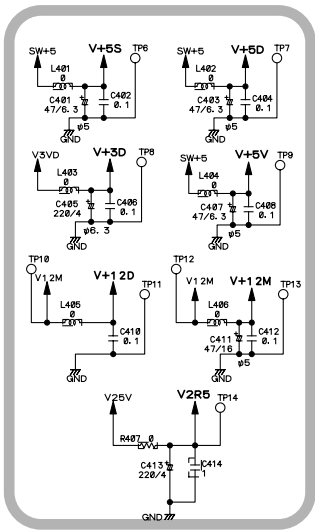

D1/3 DVDM ASSY

(VWS1446, VWS1449, VWS1447, VWS1448, VWS1450, VWS1451)

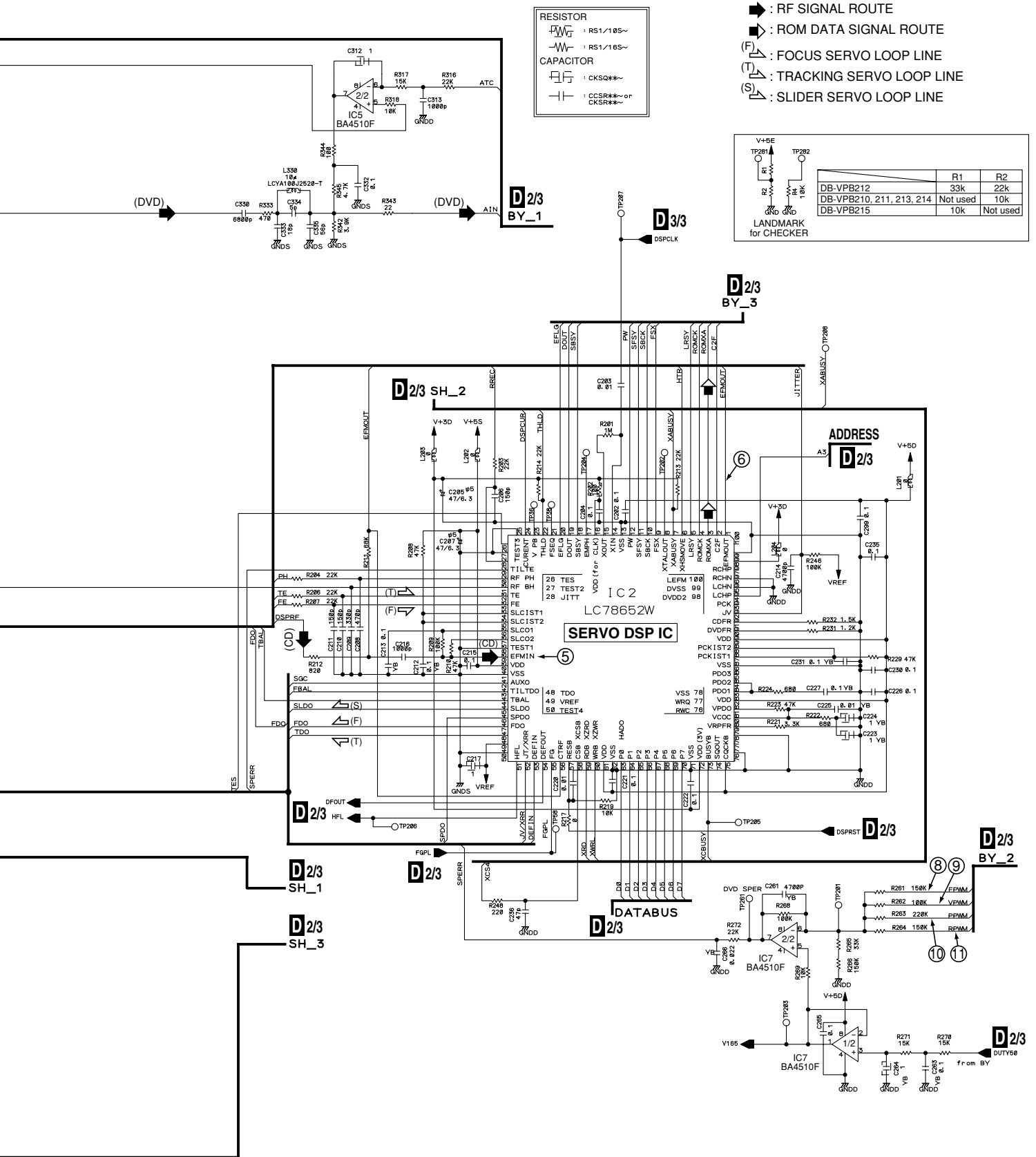

 : The power supply is shown with the marked box.



RESISTOR
 : RS1/10S~
 : RS1/10S~
CAPACITOR
 : CCSR*** or CCSR***

- ▶ : RF SIGNAL ROUTE
- ▶ : ROM DATA SIGNAL ROUTE
- (F) : FOCUS SERVO LOOP LINE
- (T) : TRACKING SERVO LOOP LINE
- (S) : SLIDER SERVO LOOP LINE

LANDMARK for CHECKER



	R1	R2
DB-VPB212	33k	22k
DB-VPB210, 211, 213, 214	Not used	10k
DB-VPB215	10k	Not used

3.1.4 DVDM ASSY (2/3)

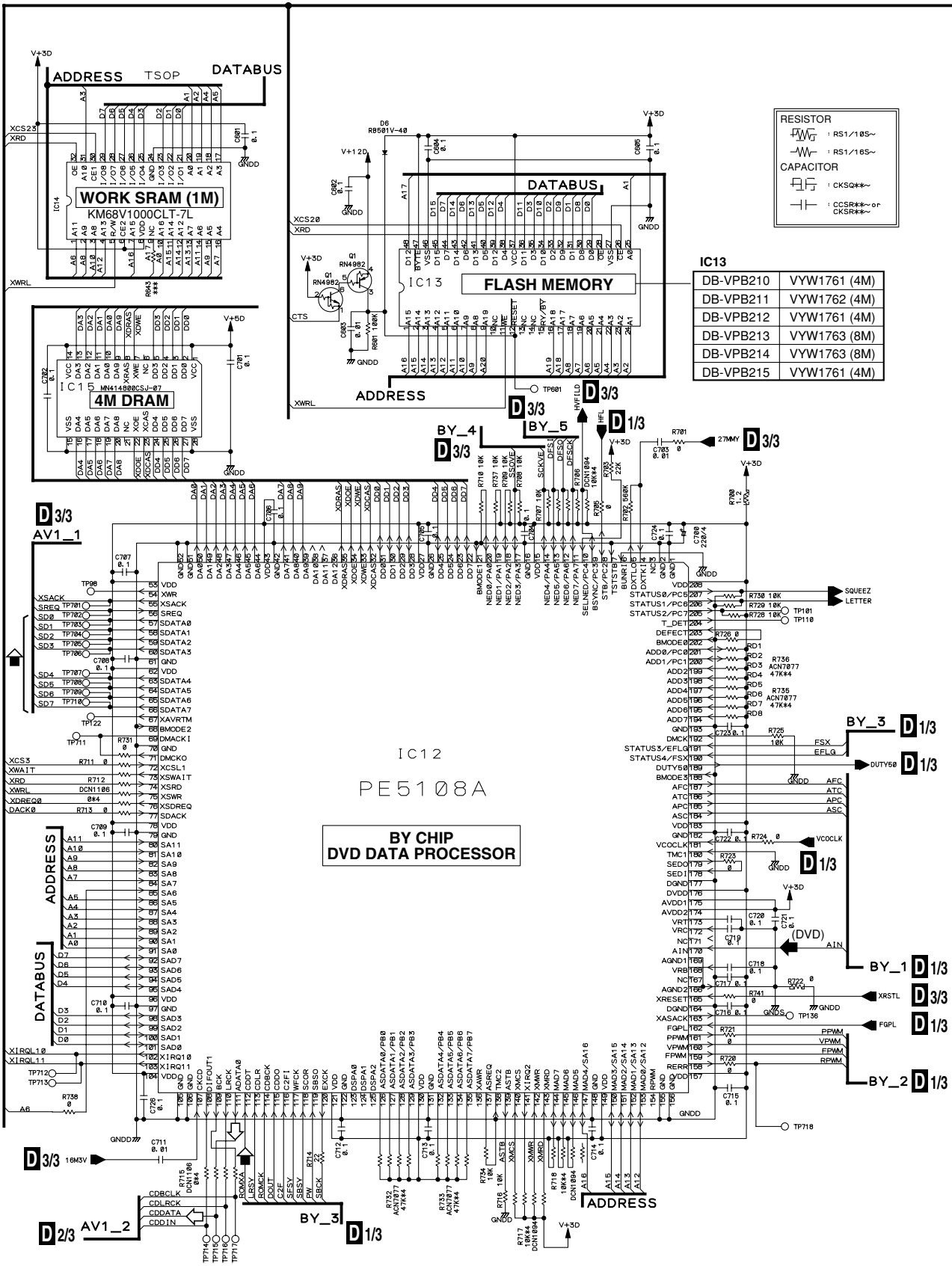
D/2/3 DVDM ASSY (VWS1446, VWS1449, VWS1447, VWS1448, VWS1450, VWS1451)



 : The power supply is shown with the marked box.

-  : RF SIGNAL ROUTE
-  : ROM DATA SIGNAL ROUTE
-  : AUDIO SIGNAL ROUTE

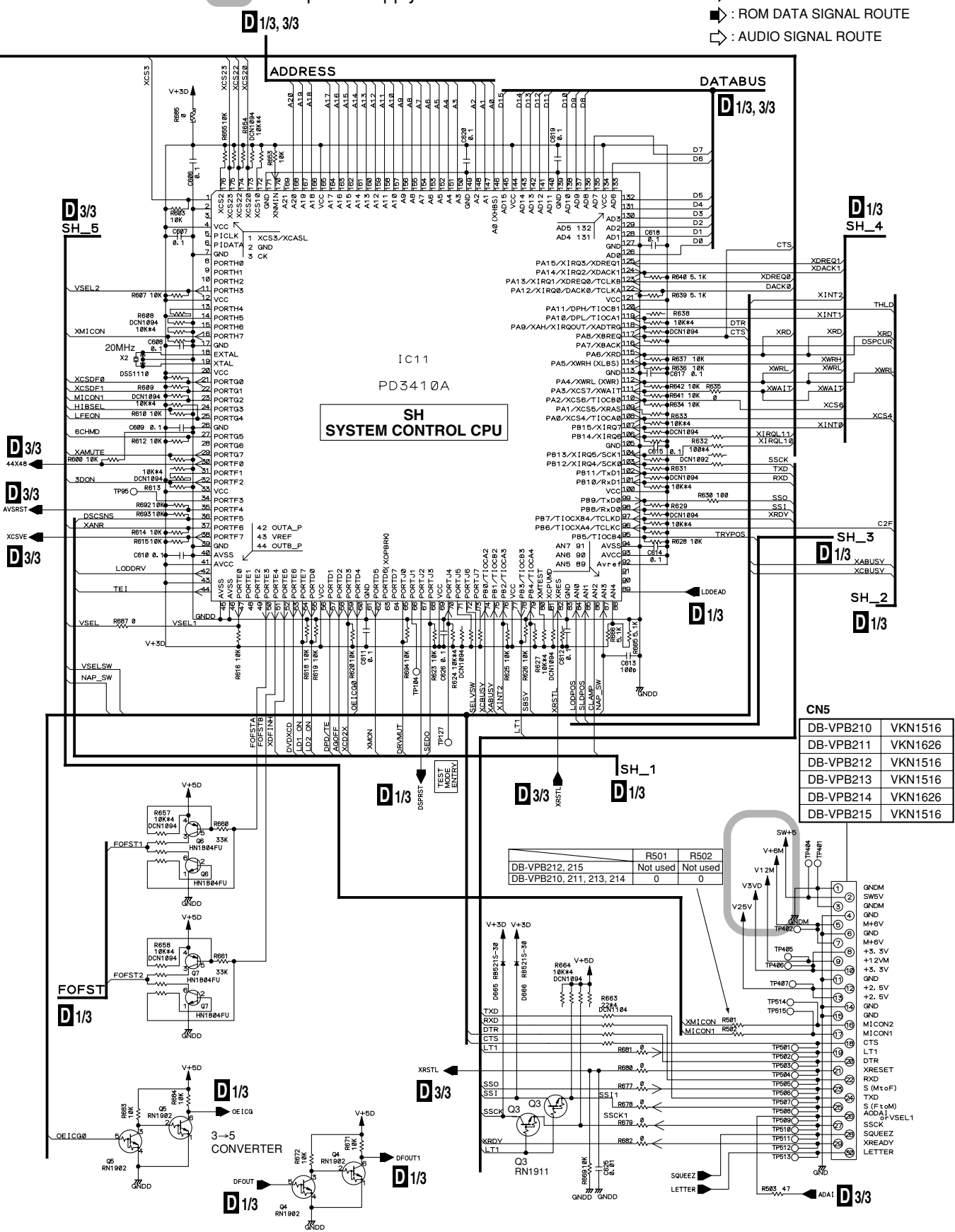

3.1.5 DVDM ASSY (3/3)

D 3/3 DVDM ASSY (VWS1446, VWS1449, VMS1447, VWS1448, VWS1450) DB-VPB210 / 211 / 212 / 213 / 214 ONLY

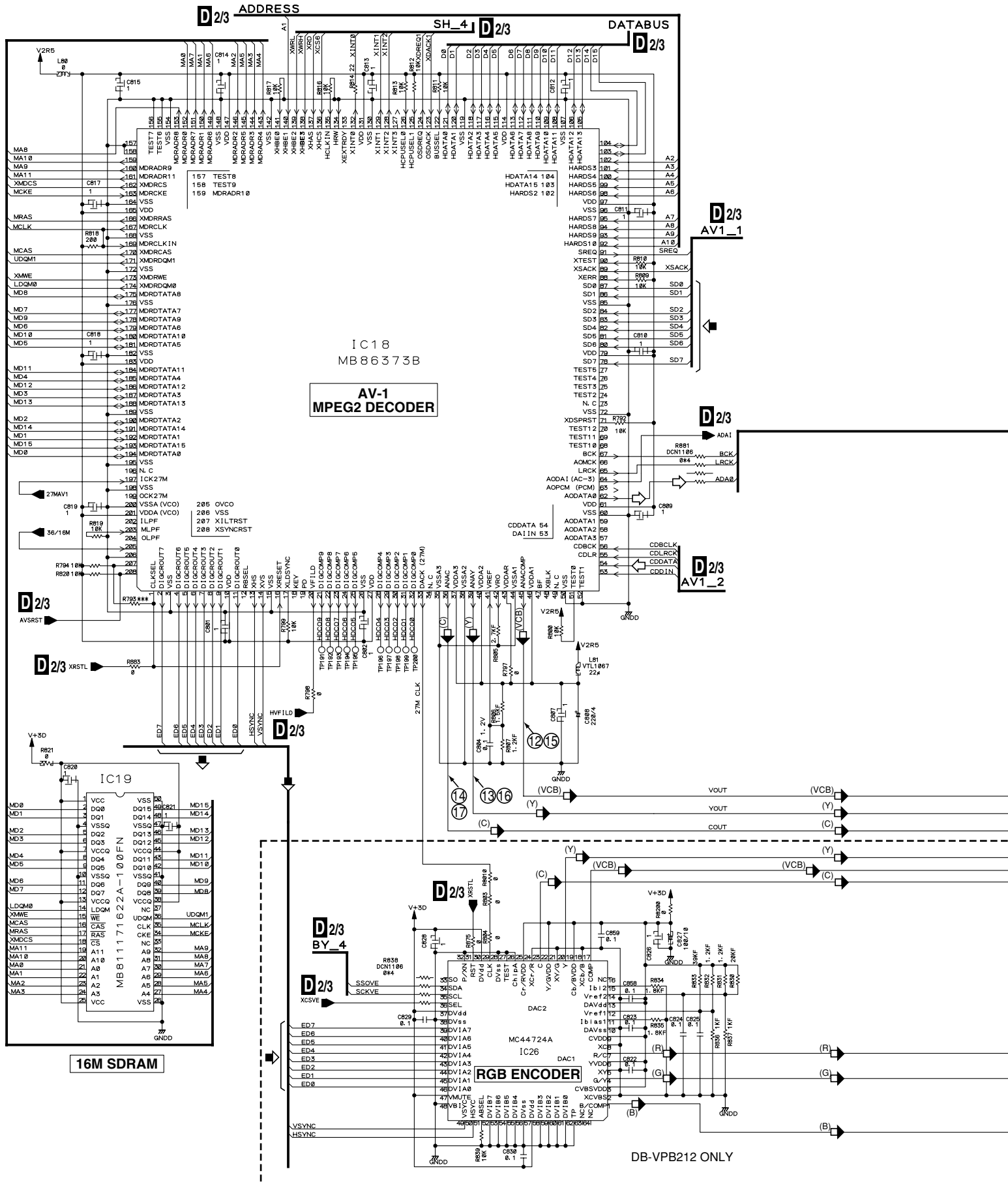

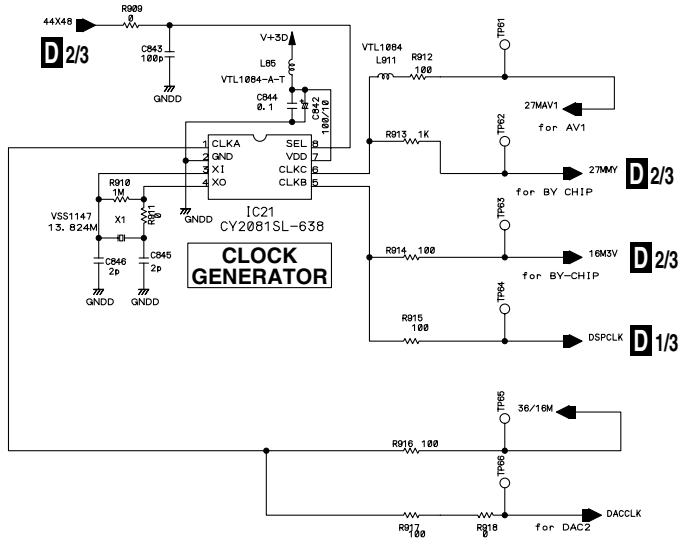

- ◁ : AUDIO SIGNAL ROUTE
- : ROM DATA SIGNAL ROUTE
- (VCB) : V/CB SIGNAL ROUTE
- (Y) : Y SIGNAL ROUTE
- (C) : C SIGNAL ROUTE
- (R) : R SIGNAL ROUTE
- (G) : G SIGNAL ROUTE
- (B) : B SIGNAL ROUTE

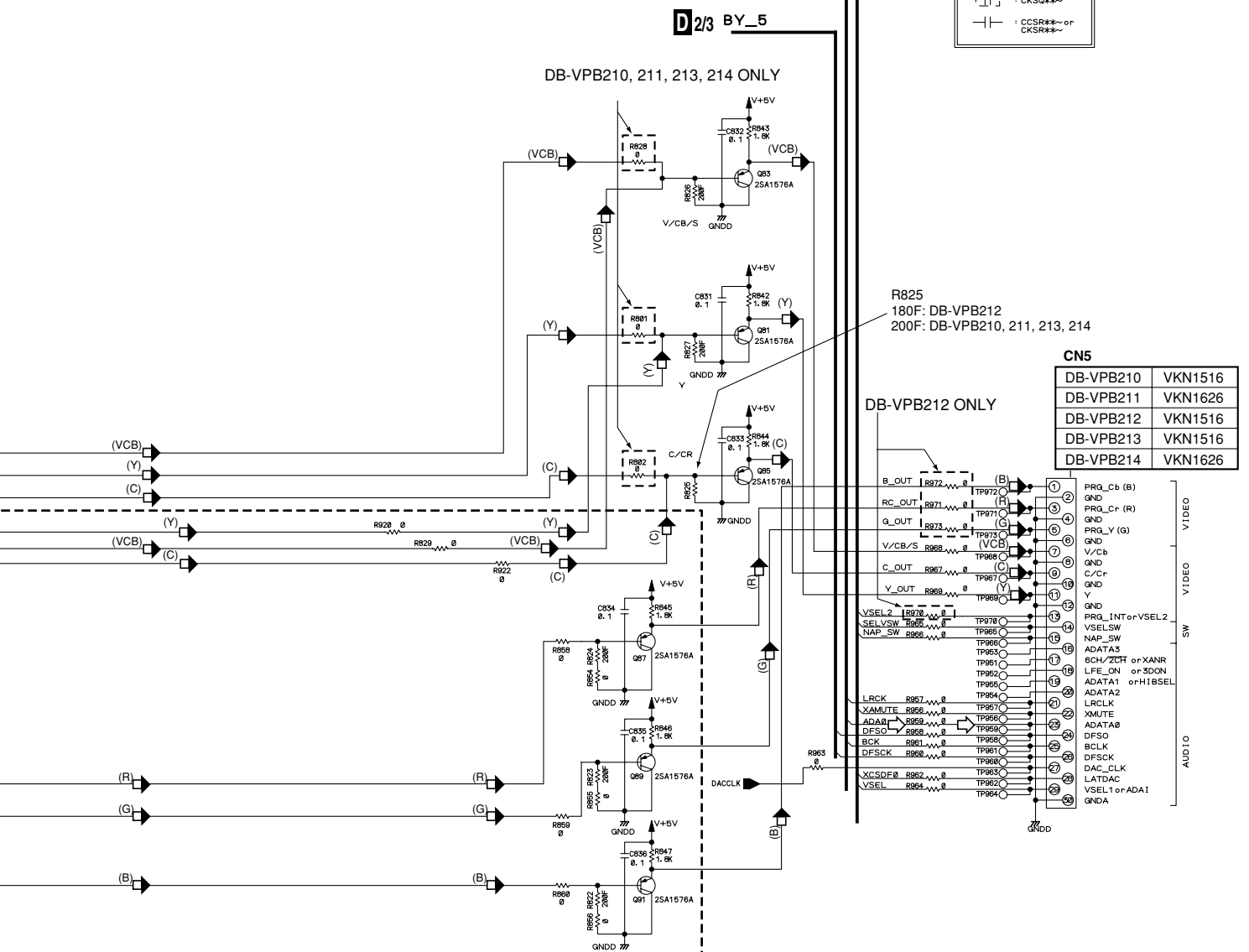
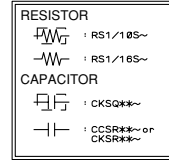

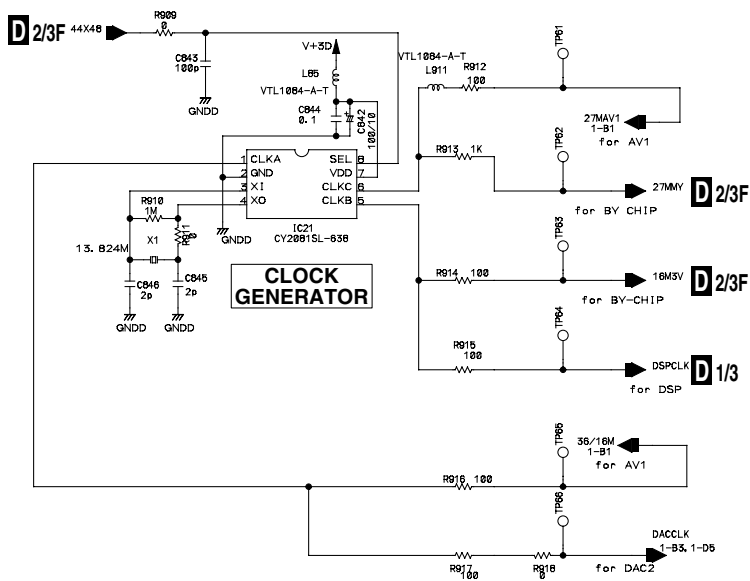

- : AUDIO SIGNAL ROUTE
- : ROM DATA SIGNAL ROUTE
- : V/CB SIGNAL ROUTE
- : Y SIGNAL ROUTE
- : C SIGNAL ROUTE

D 2/3F SH_5
(to 2/3)

D 2/3F BY_5
(to 2/3)

E 3/3F CN106

CN15
VKN1516

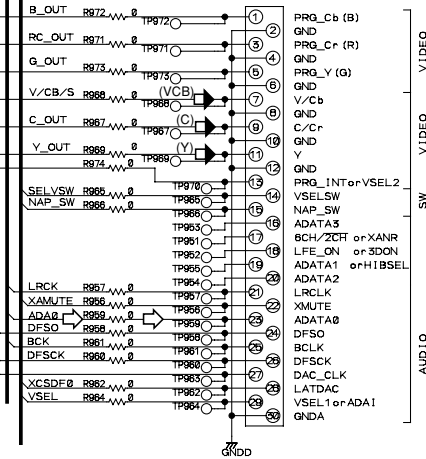

WAVEFORMS

Note : The encircled numbers denote measuring point in the schematic diagram.

Measurement condition : No. 1 to 4 and 6 to 11 : MJK1, Title 1-chp 1 or TDV-540, Title 2-chp1
 No. 5 : CD, ABEX-784 Track 1 or PHILIPS SBC 429 Track1
 No. 12 to 14 : MJK1, Title 1-chp 4 or TDV-540, Title 2-chp1
 No. 15 to 17 : MJK1, Title 1-chp 5 or TDV-540, Title 2-chp1

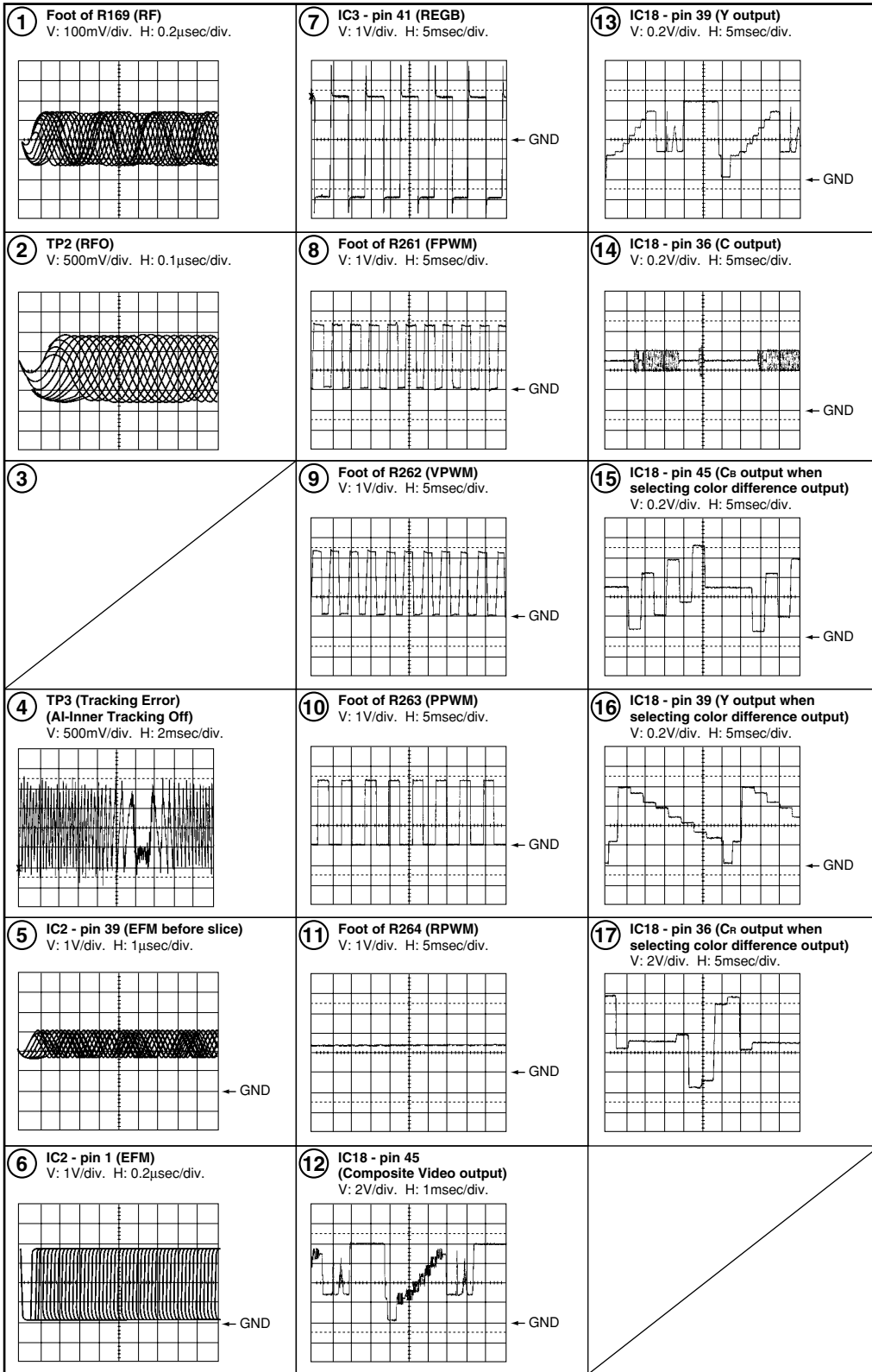

3.2 PCB CONNECTION DIAGRAM

NOTE FOR PCB DIAGRAMS :

1. Part numbers in PCB diagrams match those in the schematic diagrams.
2. A comparison between the main parts of PCB and schematic diagrams is shown below.

Symbol In PCB Diagrams	Symbol In Schematic Diagrams	Part Name
		Transistor
		Transistor with resistor
		Field effect transistor
		Resistor array
		3-terminal regulator

3. The parts mounted on this PCB include all necessary parts for several destinations.
For further information for respective destinations, be sure to check with the schematic diagram.
4. View point of PCB diagrams.

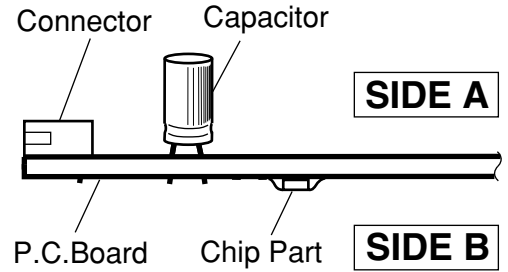

3.2.1 LOAB and SMEB ASSYS

A LOAB ASSY

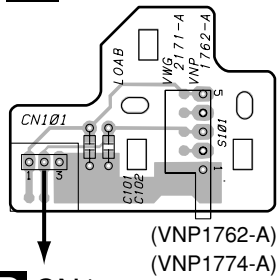

D CN1

A LOAB ASSY

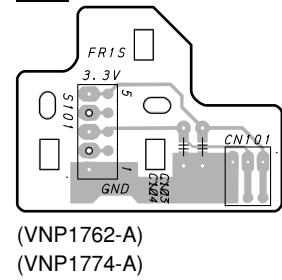

B SMEB ASSY

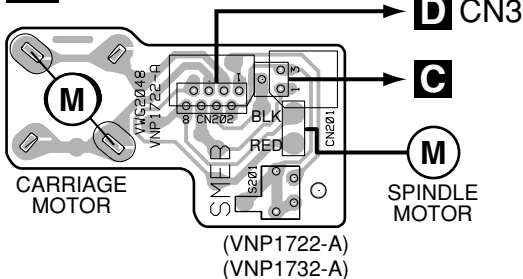

SIDE A

SIDE B

3.2.2 DVDM ASSY

D DVDM ASSY

• This PCB is a four-layered board.

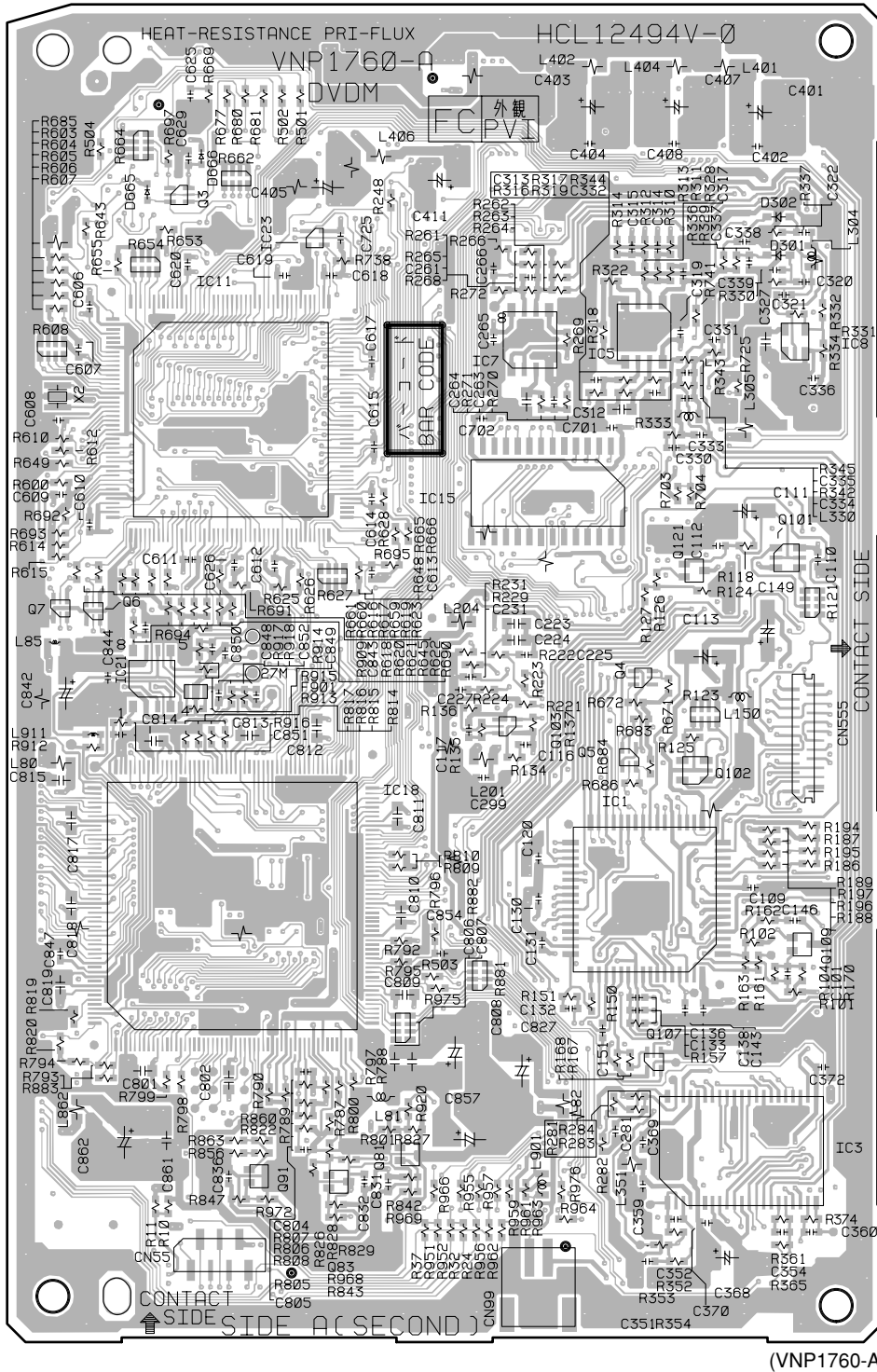

- Q3
- IC7 IC5 IC8
- IC11
- IC15
- Q121 Q101
- Q7 Q6
- IC21 Q4
- Q103
- Q5 Q102
- IC18 IC1
- Q109
- Q107
- Q81 IC3
- Q91 Q83

SIDE A

D DVDM ASSY

• This PCB is a four-layered board.

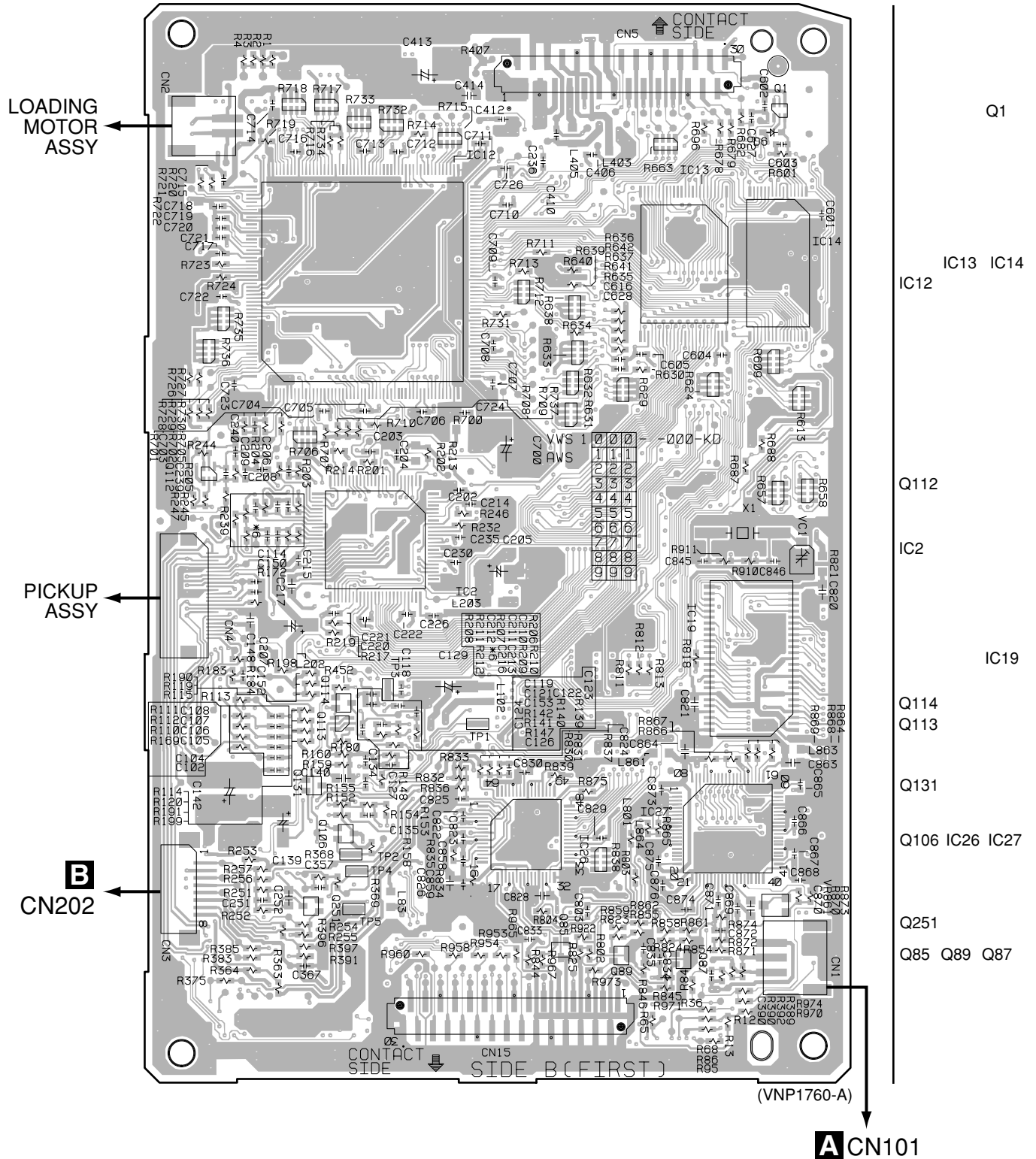

3.2.3 IC

• The information shown in the list is basic information and may not correspond exactly to that shown in the schematic diagrams.

• List of IC

LC78652W, PD3410A, MB86373B

■ LC78652W (DVDM ASSY : IC2)

• DSP IC

Block Diagram

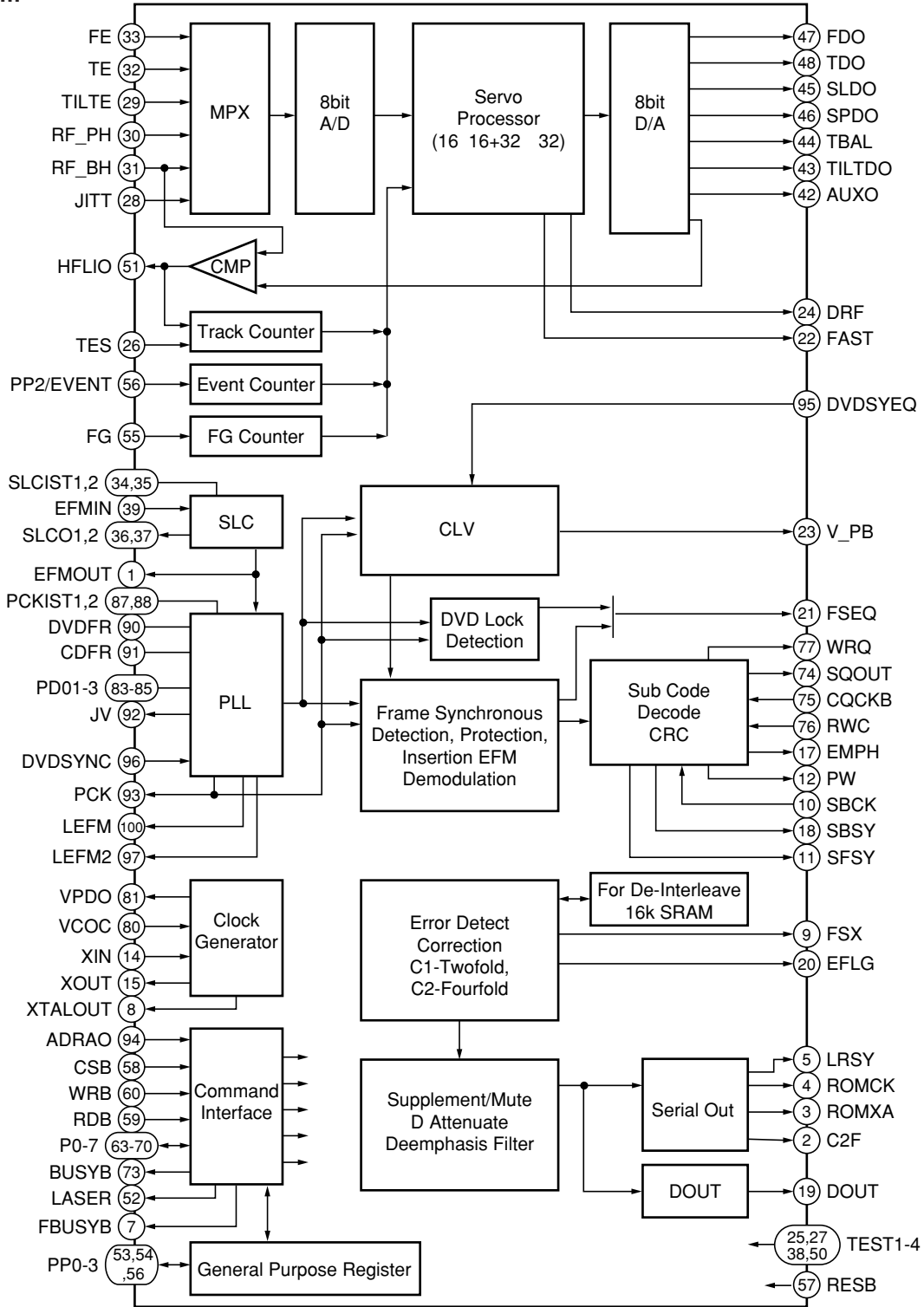

●Pin Function

No.	Pin Name	I/O	Function
1	EFMOUT	O	Output the state that was binary-stated value EFM
2	C2F	O	C2 flag output
3	ROMXA	O	CD-ROM data output
4	ROMCK	O	Shift clock output for CD-ROM data output
5	LRSY	O	L/R clock output for CD-ROM data output
6	PP3	I/O	General-purpose port input/output / DVD sync. signal input N ch-OD output
7	FBUSYB	O	Busy signal output of DSP process operation N ch-OD output
8	XTALOUT	O	External system clock output
9	FSX	O	CD 1 frame sync. signal output
10	SBCK	I	Subcode reading out clock input
11	SFSY	O	Frame sync. signal output of subcode
12	PW	O	Subcode P, Q, R, S, T, U, V and W output
13	VSS	–	GND pin
14	XIN	I	Connect a crystal resonator (16.9344MHz)
15	XOUT	O	Connect a crystal resonator
16	DVDD1	–	3.3V power supply of the oscillation circuit
17	EMPH	O	Monitor pin of the deemphasis
18	SBSY	O	Sync. signal output of the subcode block
19	DOUT	O	Audio EIAJ data output
20	EFLG	O	Error correction state monitor of the error correction C1 and C2
21	FSEQ	O	Detection monitor of the CD/DVD frame sync. signal
22	FAST	O	Playback speed monitor N ch-OD output
23	V_PB	O	Monitor output of the rough servo/CLV control
24	DRF	O	In focus monitor
25	TEST3	I	Test input 3
26	TES	I	Tracking error signal input
27	TEST2	I	Test input 2
28	JITT	I	Jitter quantity detecting signal input of EFM PLL
29	TILTE	I	Tilt error signal input
30	RF_PH	I	RF peak hold signal input
31	RF_BH	I	RF bottom hold signal input
32	TE	I	Tracking error signal input
33	FE	I	Focus error signal input
34	SLCIST1	–	Current setting pin 1 of the constant current charge pump for SLC
35	SLCIST2	–	Current setting pin 2 of the constant current charge pump for SLC
36	SLCO1	O	Control output 1 for SLC
37	SLCO2	O	Control output 2 for SLC
38	TEST1	I	Test input 1
39	EFMIN	I	EFM/EFM + input
40	AVDD	–	5V power supply of A/D and D/A for servo
41	AVSS	–	GND of A/D and D/A for servo
42	AUXO	O	DA auxiliary output
43	TILTDO	O	Tilt control signal output
44	TBAL	O	Tracking balance control signal output
45	SLDO	O	Sled control signal output
46	SPDO	O	Spindle control signal output
47	FDO	O	Focus control signal output
48	TDO	O	Tracking control signal output
49	VREF	–	Reference level of D/A for servo
50	TEST4	I	Test input 4

No.	Pin Name	I/O	Pin Function
51	HFLIO	I/O	Mirror detection signal input/output
52	LASER	O	Output pin for laser ON/OFF control
53	PP0/DVD_CDB	I/O	General-purpose port input/output / Disc discrimination signal output
54	PP1/CRCERRB	I/O	General-purpose port input/output / Subcode CRC result signal output
55	FG	I	FG counter input
56	PP2/EVENT	I/O	General-purpose port input/output / Event counter input
57	RESB	I	Reset input
58	CSB	I	Chip select input
59	RDB	I	Internal state reading signal input
60	WRB	I	Command / data writing signal input
61	DVDD2	-	5V power supply
62	VSS	-	GND
63	P0	I/O	Command / data input/output
64	P1		
65	P2		
66	P3		
67	P4		
68	P5		
69	P6		
70	P7		
71	VSS	-	GND
72	DVDD1	-	3.3V power supply for internal
73	BUSYB	O	Busy signal output of command process
74	SQOUT	O	Serial output of subcode Q
75	CQCKB	I	Shift clock input for subcode Q data output
76	RWC	I	Update permission input of subcode Q
77	WRQ	O	Read out ready monitor of subcode Q
78	AVSS	-	PLL GND for internal system clock
79	VRPFR	-	VCO oscillation range setting of PLL for system clock
80	VCOC	I	Connect a PLL filter for system clock
81	VPDO	O	
82	AVDD	-	PLL 5V power supply for system clock
83	PDO1	I/O	PLL filter connection pin 1 for EFM playback
84	PDO2	I/O	PLL filter connection pin 2 for EFM playback
85	PDO3	I/O	PLL filter connection pin 3 for EFM playback
86	AVSS	-	PLL GND for EFM playback
87	PCKIST1	-	Current setting 1 of PLL constant current charge pump for EFM playback
88	PCKIST2	-	Current setting 2 of PLL constant current charge pump for EFM playback
89	AVDD	-	PLL 5V power supply for EFM playback
90	DVDFR	-	VCO oscillation range setting of PLL for EFM playback 1
91	CDFR	-	VCO oscillation range setting of PLL for EFM playback 2
92	JV	O	Jitter output of PLL clock for EFM playback
93	PCK	O	Bit clock output for EFM playback
94	ADRAO	I	Address input
95	DVDSYEQ	I	DVD synchronize pulse input
96	DVDSYNC	I	DVD synchronous signal input
97	LEFM2	O	Output the state that cut and out a signal which was binary-stated value EFM with PCK 2
98	DVDD1	-	3.3V power supply for I/O
99	VSS	-	GND
100	LEFM	O	Output the state that cut and out a signal which was binary-stated value EFM with PCK 1

■ PD3410A (DVDM ASSY : IC11)

• System Control IC

● Pin Function

No.	Mark	Pin Name	I/O	Function
1	XCS3/XCASL	XCS3	O	PD4995A (MY CHIP) chip select signal output
2	GND	GND	–	GND
3	CK	HCPUCK	O	N.C.
4	VCC	V+3D	–	V+3D
5	PICLK	–	I/O	N.C.
6	PIDATA	–	I/O	N.C.
7	GND	GND	–	GND
8	PORTH0	–	O	N.C.
9	PORTH1	–	O	N.C.
10	PORTH2	36MVH	O	BU2158F (Clock generator)
11	PORTH3	V_SEI2	O	Composite/S switching signal output of the skirt terminal [WY model]
12	VCC	V+3D	–	V+3D
13	PORTH4	–	O	N.C.
14	PORTH5	–	O	N.C.
15	PORTH6	–	O	N.C.
16	PORTH7	–	O	N.C.
17	GND	GND	–	GND
18	EXTAL	EXTAL	I	Connect a ceramic resonator
19	XTAL	XTAL	O	
20	VCC	V+3D	–	V+3D
21	PORTG0	XCSDFO	O	DAC chip select signal output (←XLAT3)
22	PORTG1	–	O	N.C.
23	PORTG2	–	O	N.C.
24	PORTG3	–	O	N.C.
25	PORTG4	–	O	N.C.
26	GND	GND	–	GND
27	PORTG5	–	O	N.C.
28	PORTG6	–	O	N.C.
29	PORTG7	XAMUTE	O	Last stage mute signal output of the audio
30	PORTF0	44X48	O	DAC 44/48 FS switching signal output
31	PORTF1	–	I	N.C.
32	PORTF2	3DON	O	3D audio ON/bypass switching signal output
33	VCC	V+3D	–	V+3D
34	PORTF3	–	O	N.C.
35	PORTF4	XAVSRST	O	Sync. reset port
36	PORTF5	–	O	N.C.

No.	Mark	Pin Name	I/O	Function
37	PORTF6	–	O	N.C.
38	PORTF7	XCSVE	O	Serial communication enable signal output of the video encoder [WY model]
39	GND	GND	–	GND
40	AVSS	GND	–	GND
41	AVCC	V+3D	–	V+3D
42	OUTA_P	LODRV	O	Loading drive output
43	VREF	V+3D	–	V+3D
44	OUTB_P	TEI	O	Tracking offset signal output
45	AVSS	GND	–	GND
46	AVSS	GND	–	GND
47	PORTE0	V_SEL	O	Component/composite switching signal output
48	PORTE1	–	I	N.C.
49	PORTE2	–	I	N.C.
50	PORTE3	FOFST1	I/O	Focus offset adjustment output 1
51	PORTE4	FOFST2	I/O	Focus offset adjustment output 2
52	PORTE5	XDFINH	I/O	Defect shunt signal output
53	PORTE6	DVD/XC	O	DVD/CD switching signal output
54	PORTE7	LD1_ON	O	650 nm laser diode ON signal output
55	PORTD0	LD2_ON	O	780 nm laser diode ON signal output
56	VCC	V+3D	–	V+3D
57	PORTD1	DPD/TE	O	1 beam/3 beams switching signal output
58	PORTD2	AGOFF	O	AGC ON/OFF switching signal output of RF IC
59	PORTD3	XCD2X	O	Signal output for switching the double speed playback (VCD)
60	PORTD4	OEICG	O	OEIC gain switching signal output
61	GND	GND	–	GND
62	PORTD5	XMON	O	ON/OFF switching signal output of the spindle motor control output
63	PORTD6	–	O	N.C.
64	PORTD7	–	I	N.C.
65	PORTJ0	XDRVMUT	O	Driver mute output
66	PORTJ1	–	O	N.C.
67	PORTJ2	XDSPRST	O	Servo DSP reset
68	PORTJ3	–	I	N.C.
69	VCC	V+3D	–	V+3D
70	PORTJ4	TM_ENT	I	Test mode entry
71	PORTJ5	–	O	N.C.
72	PORTJ6	VSEL_SW	I	Component/composite SW input
73	PORTJ7	–	I	N.C.
74	PB0/TIOCA2	XCBUSY	I	Command busy input
75	PB1/TIOCB2	XABUSY	I	Auto-sequence busy input
76	PB2/TIOCA3	XINT2	I	Interrupt input 2 (AV-1)
77	VCC	V+3D	–	V+3D
78	PB3/TIOCB3	LT1	O	Communication response signal output to the FL controller
79	PB4/TIOCA4	SBSY	I	Subcode block sync. input
80	XMTEST	–	I	Test terminal (V+3D)
81	XCPUMD	–	I	Test terminal (V+3D)
82	XRES	XRESET	I	Reset input

No.	Mark	Pin Name	I/O	Function
83	GND	GND	–	GND
84	AN0	LODPOS	I	Loading position input
85	AN1	SLDPOS	I	Slider position input
86	AN2	–	I	N.C.
87	AN3	NAP_SW	I	NTSC/AUTO/PAL SW input
88	AN4	XOEM	I	Input terminal of OEM model protection
89	AN5	LDDEAD		Input for LD current value display
90	AN6	–	I	N.C.
91	AN7	–	I	N.C.
92	Avref	V+3D	–	V+3D
93	AVCC	V+3D	–	V+3D
94	AVSS	GND	–	GND
95	PB5/TIOCB4	–	I	N.C.
96	PB6/TIOXA4/TCLKC	C2F	I	C2 error input
97	PB7/TIOXB4/TCLKD	XRDF	I	Communication request input from the FL controller
98	PB8/RxD0	SSI	I	Serial data input (FL controller)
99	PB9/TxD0	SSO	O	Serial data output (FL controller)
100	VCC	V+3D	–	V+3D
101	PB10/RxD1	RXD	I	Data input of the RS-232C
102	PB11/TxD1	TXD	O	Data output of the RS-232C
103	PB12/XIRQ4/SCK0	SSCK	I/O	Serial clock output (FL controller)
104	PB13/XIRQ5/SCK1	XIRQL10	I	Interrupt input #0 (MY CHIP)
105	GND	GND	–	GND
106	PB14/XIRQ6	XIRQL11	I	Interrupt input #1 (MY CHIP)
107	PB15/XIRQ7	XINT0	I	Interrupt input #0 (AV-1)
108	PA0/XCS4/TIOCA0	XCS4	O	Servo DSP chip select signal output
109	PA1/XCS5/XRAS	–	O	N.C.
110	PA2/XCS6/TIOCB0	XCS6	O	AV-1 chip select signal output
111	XWAIT	XWAIT	I	Wait signal input
112	XWRL	XWRL	O	Write pulse output L
113	GND	GND	–	GND
114	XWRH	XWRH	O	Write pulse output H
115	XRD	XRD	O	Read pulse output
116	PA7/XBACK	XCURDET	I	Over-current detection signal input
117	PA8/XBREQ	CTS	I	RS-232C transfer permit input
118	PA9/XAH/XIRQOUT/ XADTRG	DTR	O	RS-232C transfer permit output
119	PA10/DPL/TIOCA1	XINT1	I	Interrupt input 1 (AV-1)
120	PA11/DPH/TIOCB1	THLD	I	Tracking hold signal input
121	VCC	V+3D	–	V+3D
122	PA12/XIRQ0/DACK0/ TCLKA	DACK0	O	DMA response output (MY CHIP)
123	PA13/XIRQ1/ XDREQ0/TCLKB	XDREQ0	I	DMA request input (MY CHIP)
124	PA14/XIRQ2/XDACK1	XDACK1	O	DMA response output (AV-1)
125	PA15/XIRQ3/XDREQ1	XDREQ1	I	DMA request input (AV-1)
126	AD0	D0	I/O	Data bus 0

No.	Mark	Pin Name	I/O	Function
127	GND	GND	–	GND
128	AD1	D1	I/O	Data bus 1
129	AD2	D2	I/O	Data bus 2
130	AD3	D3	I/O	Data bus 3
131	AD4	D4	I/O	Data bus 4
132	AD5	D5	I/O	Data bus 5
133	AD6	D6	I/O	Data bus 6
134	VCC	V+3D	–	V+3D
135	AD7	D7	I/O	Data bus 7
136	AD8	D8	I/O	Data bus 8
137	AD9	D9	I/O	Data bus 9
138	AD10	D10	I/O	Data bus 10
139	GND	GND	–	GND
140	AD11	D11	I/O	Data bus 11
141	AD12	D12	I/O	Data bus 12
142	AD13	D13	I/O	Data bus 13
143	AD14	D14	I/O	Data bus 14
144	VCC	V+3D	–	V+3D
145	AD15	D15	I/O	Data bus 15
146	A0 (XHBS)	A0	O	Address bus 0
147	A1	A1	O	Address bus 1
148	A2	A2	O	Address bus 2
149	GND	GND	–	GND
150	A3	A3	O	Address bus 3
151	A4	A4	O	Address bus 4
152	A5	A5	O	Address bus 5
153	A6	A6	O	Address bus 6
154	A7	A7	O	Address bus 7
155	A8	A8	O	Address bus 8
156	A9	A9	O	Address bus 9
157	A10	A10	O	Address bus 10
158	A11	A11	O	Address bus 11
159	A12	A12	O	Address bus 12
160	A13	A13	O	Address bus 13
161	A14	A14	O	Address bus 14
162	A15	A15	O	Address bus 15
163	A16	A16	O	Address bus 16
164	A17	A17	O	Address bus 17
165	VCC	V+3D	–	V+3D
166	A18	A18	O	Address bus 18
167	A19	A19	O	Address bus 19
168	A20	A20	O	Address bus 20 [RAM model]
169	A21	A21	O	N.C.
170	XNMI	XNMI	I	V+3D
171	GND	GND	–	GND
172	XCS10	–	O	N.C.
173	XCS20	XCS20	O	Chip select signal output of the flash ROM
174	XCS22	–	O	Chip select signal output of the GUI ROM [OEM model]
175	XCS23	XCS23	O	Chip select signal output of the SRAM
176	XCS2	–	O	N.C.

■ MB86373B (DVDM ASSY : IC18)

- MPEG2 Decoder IC

● Block Diagram

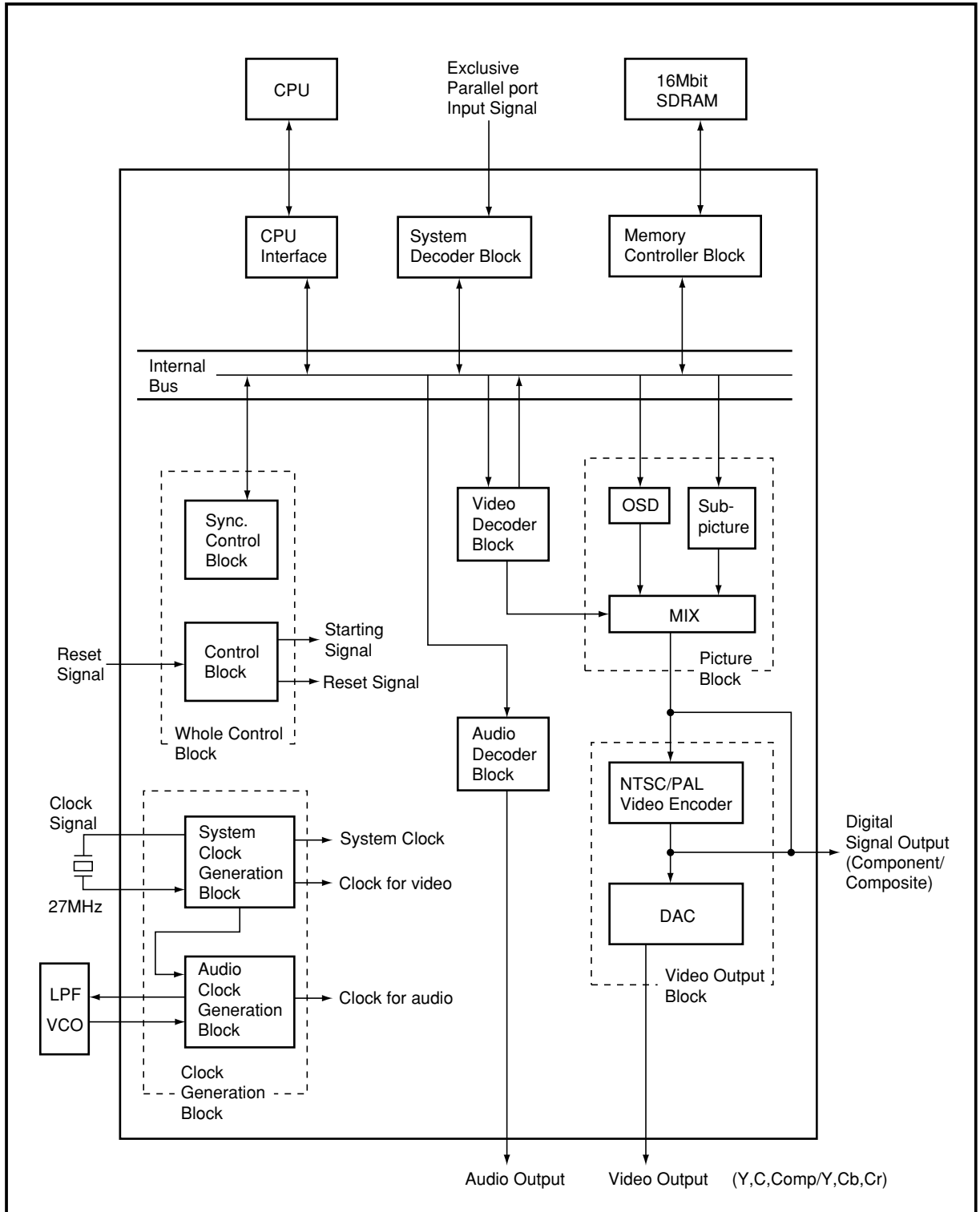

● Pin Function

No.	Pin Name	I/O	Function	No.	Pin Name	I/O	Function
1	CLKSEL	I	ON/OFF signal of PLL ("H" : ON, "L" : OFF)	27	VDD	–	2.5V power supply
2	DIGCPN7	O	Digital component signal output (MSB) Digital Y signal output (9-bit) (MSB)	28	DIGCOMP4	O	Digital composite signal output Digital C signal output
3	VSS	–	GND	29	DIGCOMP3		
4	DIGCPN6	O	Digital component signal output Digital Y signal output (9-bit)	30	DIGCOMP2		
5	DIGCPN5			31	DIGCOMP1		
6	DIGCPN4			32	DIGCOMP0		
7	DIGCPN3			33	DACK	O	27 MHz clock output
8	DIGCPN2			34	N.C.	–	Non connection
9	DIGCPN1			35	VSSA3	–	GND (D/A converter)
10	VDD	–	2.5V power supply	36	ANAC	O	Analog color (C) output signal
11	DIGCPN0	O	Digital component signal output (LSB) Digital Y signal output (9-bit) (LSB)	37	VDDA3	–	2.5V power supply (for built-in D/A converter only)
12	RBSEL	O	Cb and Cr discrimination signal at the digital component signal output. LSB at the digital Y signal output.	38	VSSA2	–	GND (D/A converter)
13	XHS	O	Horizontal sync. output signal	39	ANAY	O	Analog luminance (Y) output signal
14	XVS	O	Vertical sync. output signal	40	VDDA2	–	2.5V power supply (for built-in D/A converter only)
15	VSS	–	GND	41	VREF	I	Reference voltage for D/A converter
16	XRESET	I	LSI reset signal	42	VRO	O	Internal current setting pin of D/A converter
17	XLDCSYNC	I	External sync. signal input (LD mode)	43	VDDA4	–	2.5V power supply (for built-in D/A converter only)
18	KEY	O	KEY signal for LD and OSD overlay (LD mode)	44	VSSA1	–	GND (D/A converter)
19	PD	O	Phase comparison result output signal of horizontal sync. (LD mode)	45	ANACOMP	O	Analog composite output signal
20	VFLD	O	Field discrimination signal at the digital signal output H : even field L : odd field	46	VDDA1	–	2.5V power supply (for built-in D/A converter only)
21	DIGCOMP9	O	Digital composite signal output (MSB) Digital C signal output (MSB)	47	BF	O	Burst flag signal
22	DIGCOMP8			48	XBLK	O	H/V composite blanking signal
23	DIGCOMP7			49	TEST4	O	Normally, set to "open".
24	DIGCOMP6			50	VSS	–	GND
25	DIGCOMP5			51	TEST0	I	Normally, set to "open".
26	VSS	–	GND	52	TEST1	I	"L" status normally

No.	Pin Name	I/O	Function	No.	Pin Name	I/O	Function
53	DAIIN	I	Digital data input of external input (SPDIF)	92	HADRS10	I	CPU address bus signal (MSB)
54	CDDATA	I	Audio data input of external input (correspond to CD)	93	HADRS9	I	CPU address bus signal
55	CDLR	I	Data channel clock input of external input (correspond to CD)	94	HADRS8		
56	CDBCK	I	Data clock input of external input (correspond to CD)	95	HADRS7		
57	AODATA3	O	Audio decode data	96	VSS	-	GND
58	AODATA2			97	VDD	-	2.5V power supply
59	AODATA1			98	HADRS6	I	CPU address bus signal
60	VSS	-	GND	99	HADRS5		
61	VDD	-	2.5V power supply	100	HADRS4		
62	AODATA0	O	Audio decode data	101	HADRS3		
63	AOPCM	O	Digital audio interface output (compression data)	102	HADRS2	I/O	CPU address bus signal (LSB)
64	AODAI	O	Digital audio interface output (decode data)	103	HDATA15		CPU data bus signal (MSB)
65	LRCK	O	Data channel clock for D/A and digital filter	104	HDATA14	I/O	CPU data bus signal
66	AOMCK	O	Master clock for D/A and digital filter	105	HDATA13		
67	BCK	O	Bit clock for D/A and digital filter	106	HDATA12		
68	TEST2	I	Normally, set to "open"	107	VSS	-	GND
69	TEST3			108	HDATA11	I/O	CPU data bus signal
70	NC	-	Non connection	109	HDATA10		
71	XDSPRST	I	Normally, set to "open".	110	HDATA9		
72	VSS	-	GND	111	HDATA8		
73	TEST5	O	Normally, set to "open".	112	HDATA7	I/O	CPU data bus signal
74	NC	-	Normally, set to "open".	113	HDATA6		
75	NC			114	VDD		
76	NC			115	HDATA5	I/O	CPU data bus signal
77	NC			116	HDATA4		
78	SD7	I	Parallel data input	117	HDATA3	I/O	CPU data bus signal
79	VDD	-	2.5V power supply	118	HDATA2		
80	SD6	I	Parallel data input	119	VSS	-	GND
81	SD5			120	HDATA1	I/O	CPU data bus signal
82	SD4			121	HDATA0		CPU data bus signal (LSB)
83	SD3			122	BUSSEL	I	Bus width selection signal (0 : 8-bit bus, 1 : 16-bit bus)
84	SD2			123	XOSDACK	I	OSD data acknowledge signal
85	VSS	-	GND	124	XOSDREQ	O	OSD data request signal
86	SD1	I	Parallel data input	125	HCPUSEL1	I	CPU selection signal (00 :SPARC, 01 :86 system, 10 :68 system, 11 :Reserve)
87	SD0			126	HCPUSEL0		
88	XERR	I	Error input signal	127	XINT3	O	Interrupt request signal to the CPU
89	XSACK	I	Acknowledge signal	128	XINT2		
90	XTEST	I	Set to "H" at normal use	129	XINT1		
91	SREQ	O	Data request signal	130	VSS	-	GND

No.	Pin Name	I/O	Function	No.	Pin Name	I/O	Function
131	VDD	–	2.5V power supply	170	XMDRCAS	O	CAS signal for SDRAM
132	XINT0	O	Interrupt request signal to CPU	171	XMDRDQM1	O	Input mask / output enable signal for SDRAM
133	XEXTRDY	O	SPARC, 68 system : Ready signal to CPU 86 system : Acknowledge (ACK) signal to CPU	172	VSS	–	GND
134	HRW	I	CPU read / write signal	173	XMDRWE	O	Write enable signal for SDRAM
135	HCLKIN	I	Host clock input	174	XMDRDQM0	O	Input mask / output enable signal for SDRAM
136	XHCS	I	LSI chip select signal	175	MDRDAT8	I/O	Data bus signal for SDRAM
137	XHAS	I	SPARC, 68 system : CPU address strobe 86 system : CPU address status	176	VSS	–	GND
138	XHBE3	I	CPU byte enable signal	177	MDRDAT7	I/O	Data bus signal for SDRAM
139	XHBE2			178	MDRDAT9		
140	XHBE1			179	MDRDAT6		
141	XHBE0			180	MDRDAT10		
142	VSS	–	GND	181	MDRDAT5		
143	MDRADR4	O	Address signal for SDRAM	182	VSS	–	GND
144	MDRADR3			183	VDD	–	2.5V power supply
145	MDRADR5			184	MDRDAT11	I/O	Data bus signal for SDRAM
146	MDRADR2			185	MDRDAT14		
147	VDD	–	2.5V power supply	186	MDRDAT12		
148	VSS	–	GND	187	MDRDAT3		
149	MDRADR6	O	Address signal for SDRAM	188	MDRDAT13		
150	MDRADR1			189	VSS	–	GND
151	MDRADR7			190	MDRDAT2	I/O	Data bus signal for SDRAM
152	MDRADR0			191	MDRDAT14		
153	MDRADR8	192	MDRDAT1				
154	VSS	–	GND	193	MDRDAT15		
155	TEST6	I	"L" status normally	194	MDRDAT0	I/O	Data bus signal for SDRAM (LSB)
156	TEST7			195	VSS	–	GND
157	TEST8			196	N.C.	–	Non connection
158	TEST9			197	ICK27M	I	System clock input
159	MDRADR10	O	Address signal for SDRAM	198	VSS	–	GND
160	MDRADR9			199	OCK27M	O	System clock output
161	MDRADR11			200	VSSA(VCO)	–	GND (for VCO only)
162	XMDRCS	O	Chip select signal for SDRAM	201	VDDA(VCO)	–	2.5V power supply (for VCO only)
163	MDRCKE	O	Clock enable signal for SDRAM	202	ILPF	O	PLL block inverter output for audio
164	VSS	–	GND	203	MLPF	I	PLL block inverter input for audio
165	VDD	–	2.5V power supply	204	OLPF	O	Phase detector output for audio
166	XMDRRAS	O	RAS signal for SDRAM	205	OVCO	I	VCO input for audio clock
167	MDRCLK	O	Clock output signal for SDRAM	206	VSS	–	GND
168	VSS	–	GND	207	XPLLST	I	PLL section reset signal
169	MDRCLKIN	I	Clock input signal for SDRAM	208	XSYNCRST	I	SYNC reset signal

3.3 PCB PARTS LIST

- NOTES: ● Parts marked by "NSP" are generally unavailable because they are not in our Master Spare Parts List.
 ● The Δ mark found on some component parts indicates the importance of the safety factor of the part. Therefore, when replacing, be sure to use parts of identical designation.
 ● When ordering resistors, first convert resistance values into code form as shown in the following examples.
 Ex.1 When there are 2 effective digits (any digit apart from 0), such as 560 ohm and 47k ohm (tolerance is shown by J=5%, and K=10%).
- | | | | | | | | | | |
|--------------|---------------|------------------|---------------|----------|---------|---|---|---|---|
| 560 Ω | \rightarrow | 56×10^1 | \rightarrow | 561..... | RD1/4PU | 5 | 6 | 1 | J |
| 47k Ω | \rightarrow | 47×10^3 | \rightarrow | 473..... | RD1/4PU | 4 | 7 | 3 | J |
| 0.5 Ω | \rightarrow | R50..... | | | RN2H | R | 5 | 0 | K |
| 1 Ω | \rightarrow | 1R0..... | | | RS1P | 1 | R | 0 | K |
- Ex.2 When there are 3 effective digits (such as in high precision metal film resistors).
- | | | | | | | | | | | |
|----------------|---------------|-------------------|---------------|-----------|---------|---|---|---|---|---|
| 5.62k Ω | \rightarrow | 562×10^1 | \rightarrow | 5621..... | RN1/4PC | 5 | 6 | 2 | 1 | F |
|----------------|---------------|-------------------|---------------|-----------|---------|---|---|---|---|---|

A LOAB ASSY

Mark	Ver. (DB-VPBxxx)	No.	Part No. (for PCS)	Description	Part No. (for MJL)
NSP NSP		SWITCH S101	9965 000 07961	VSK1011	*SM000340R
		OTHERS CN101	—	S3B-PH-K-S, KR CONNECTOR	—
		—	—	VNP1762, PC BOARD LOAB	—

B SMEB ASSY

Mark	Ver. (DB-VPBxxx)	No.	Part No. (for PCS)	Description	Part No. (for MJL)
NSP NSP NSP NSP	210,211,213,214,215 212	SWITCH S201	9965 000 07962	DSG1016	*SP001020R
		OTHERS CN201	—	52044-0345, 3P FFC CONNECTOR	—
		CN202	—	VKN1212, 8P FFC CONNECTOR	—
		—	—	VNP1695, PC BOARD SMEB	—
		—	—	VNP1722, PC BOARD SMEB	—

C FGSB ASSY

Mark	Ver. (DB-VPBxxx)	No.	Part No. (for PCS)	Description	Part No. (for MJL)
NSP		SEMICONDUCTOR PC101	9965 000 07963	GP2S60	*HW100500R
		RESISTOR R101	—	RS1/10S331J	—

D DVDM ASSY

Mark	Ver. (DB-VPBxxx)	No.	Part No. (for PCS)	Description	Part No. (for MJL)		
		SEMICONDUCTORS					
		IC21	9965 000 07964	CY2081SL-638	*HC106340R		
		IC14	9965 000 07965	KM68V1000CLT-7L	*HC106350R		
		IC1	9965 000 07966	LA9701M	*HC105850R		
		IC2	9965 000 07967	LC78652W	*HC105860R		
		IC3	9965 000 07968	M56788FP	*HC105870R		
		IC19	9965 000 07969	MB811171622A-100FN	*HC106040R		
		IC18	9965 000 07970	MB86373B	*HC106360R		
		IC26	9965 000 07971	MC44724A	*HC106640R		
		IC15	9965 000 07972	MN414800CSJ-07	*HC105900R		
		IC5,IC7	4822 209 30455	NJM2100M (or BA4510F)	HC10085090		
		IC11	9965 000 07973	PD3410A	*HU100400R		
		215		IC27	—	PM0026A	*HC106770R

Mark	Ver. (DB-VPBxxx)	No.	Part No. (for PCS)	Description	Part No. (for MJI)
		IC12	9965 000 07974	PE5108A	*HC106370R
		IC8	4822 209 17539	TC7SHU04F	*HC105940R
	210,212,215	IC13	9965 000 07975	VYW1761 (4M)	*HC106750R
	211	IC13	—	VYW1762 (4M)	*HC106760R
	213,214	IC13	—	VYW1763 (8M)	*HC106380R
		Q106,Q109,Q81,Q83,Q85	4822 130 10698	2SA1576A	HX100012A0
	212,215	Q87,Q89,Q91	4822 130 10698	2SA1576A	HX100012A0
		Q114,Q121,Q251	4822 130 60669	2SC4081	HX300012A0
		Q131	9965 000 07976	DTC114EUA	*BA000910R
		Q102	4822 130 63838	HN1A01F	BA10011050
		Q103,Q6,Q7	9965 000 07977	HN1B04FU	*BA000920R
		Q101	4822 130 63843	HN1C01F	*BA000930R
		Q112,Q113	9965 000 07978	HN1C01FU	*BA000940R
		Q107,Q4,Q5	9965 000 07979	RN1902	*BA001020R
		Q3	9965 000 07980	RN1911	*BA000960R
		Q1	9965 000 07981	RN4982	*BA001030R
		D301	9965 000 07982	KV1471E	*HZ400020R
		D6	9322 154 46685	RB501V-40	*HZ200100R
		D665,D666	9965 000 06882	RB521S-30	*HZ200110R
		COILS			
NSP		L150,L330	—	LCYA100J2520	—
NSP		L304	—	LCYA2R7J2520	—
NSP		L81	—	VTL1067, CHIP COIL	—
		L85,L911	9965 000 07983	VTL1084, CHIP BEADS	*FC900240R
		CAPACITORS			
NSP		C123,C146,C613,C843	—	CCSRCH101J50	—
NSP		C322	—	CCSRCH120J50	—
NSP		C135	—	CCSRCH121J50	—
NSP		C104-C108	—	CCSRCH150J50	—
NSP		C206,C210,C211	—	CCSRCH151J50	—
NSP		C333	—	CCSRCH180J50	—
NSP		C116,C151,C314	—	CCSRCH220J50	—
NSP		C152	—	CCSRCH221J50	—
NSP		C127,C209,C337	—	CCSRCH331J50	—
NSP		C134,C236	—	CCSRCH470J50	—
NSP		C122,C208	—	CCSRCH471J50	—
NSP		C126,C335	—	CCSRCH560J50	—
NSP		C334	—	CCSRCH5R0C50	—
NSP		C124,C132	—	CCSRCH680J50	—
NSP		C117,C240,C352,C360	—	CCSRCH681J25	—
NSP		C845,C846	—	CCSRCK2R0C50	—
NSP		C129,C142,C842	—	CEV101M10	—
NSP	212	C827	—	CEV101M10	—
NSP		C113,C139	—	CEV220M16	—
NSP		C405,C413,C700,C808	—	CEV221M4	—
NSP		C111,C149,C205,C207,C401	—	CEV470M6R3	—
NSP		C403,C407	—	CEV470M6R3	—
NSP		C140,C223,C224,C252,C264	—	CKSQYB105K10	—
NSP		C312	—	CKSQYB105K10	—
NSP		C148,C217,C327,C414	—	CKSQYF105Z16	—
NSP		C801,C802,C807,C809-C815	—	CKSQYF105Z16	—
NSP		C817-C821	—	CKSQYF105Z16	—
NSP	212	C826,C828	—	CKSQYF105Z16	—
NSP		C216,C313	—	CKSRYB102K50	—
NSP		C133,C136,C203,C220,C225	—	CKSRYB103K50	—
NSP		C239,C320,C321,C603,C625	—	CKSRYB103K50	—
NSP		C703,C711	—	CKSRYB103K50	—
NSP		C101,C102,C114,C118,C119	—	CKSRYB104K16	—
NSP		C121,C138,C204,C212,C213	—	CKSRYB104K16	—
NSP		C227,C231,C263,C315,C317	—	CKSRYB104K16	—
NSP		C332,C804	—	CKSRYB104K16	—
NSP		C153,C266	—	CKSRYB223K25	—
NSP		C357	—	CKSRYB223K50	—
NSP		C354	—	CKSRYB332K50	—
NSP		C214,C251,C261,C351	—	CKSRYB472K50	—
NSP		C330	—	CKSRYB682K50	—
NSP		C109,C110,C120,C130,C131	—	CKSRYF104Z16	—
NSP		C143,C150,C202,C215	—	CKSRYF104Z16	—
NSP		C221,C222,C226,C230,C235	—	CKSRYF104Z16	—

Mark	Ver. (DB-VPBxxx)	No.	Part No. (for PCS)	Description	Part No. (for MJI)
NSP		C265,C299,C319,C359,C367	—	CKSRYF104Z16	—
NSP		C369,C370,C402,C404,C406	—	CKSRYF104Z16	—
NSP		C408,C410,C412,C601,C602	—	CKSRYF104Z16	—
NSP		C604-C612,C614,C615	—	CKSRYF104Z16	—
NSP		C617-C620,C626,C701,C702	—	CKSRYF104Z16	—
NSP		C704-C710,C712-C724,C726	—	CKSRYF104Z16	—
NSP		C831-C833,C844	—	CKSRYF104Z16	—
NSP	212	C822-C825,C829,C830	—	CKSRYF104Z16	—
NSP	212	C834-C836,C858,C859	—	CKSRYF104Z16	—
NSP	215	C834-C836,C865-C869,C871-C876	—	CKSRYF104Z16	—
NSP	215	C861-C864	—	CKSRYF105Z16	—
NSP	215	C870	—	CKSQYB104Z25	—
NSP		C368,C411 (47mF/16V)	—	VCH1166	—
RESISTORS					
NSP		R123 (39 OHM)	—	ACN7047	—
NSP		R732,R733,R735,R736 (47k OHM)	—	ACN7077	—
NSP		R632 (100OHM)	—	DCN1092	—
NSP		R608,R609,R613,R624,R627 (10k OHM)	—	DCN1094	—
NSP		R629,R631,R633,R638,R654 (10k OHM)	—	DCN1094	—
NSP		R657,R658,R664,R706 (10kOHM)	—	DCN1094	—
NSP		R717,R718 (10k OHM)	—	DCN1094	—
NSP		R121,R663 (10k OHM)	—	DCN1104	—
NSP		R712,R715,R881 (0 OHM)	—	DCN1106	—
NSP	212	R838 (0 OHM)	—	DCN1106	—
NSP		R1020,R2010,R2020,R2030,R2040	—	RS1/10S0R0J	—
NSP		R3050,R4010,R4020,R4030,R4040	—	RS1/10S0R0J	—
NSP		R4050,R4060,R407,R685,R722	—	RS1/10S0R0J	—
NSP		R8000,R821	—	RS1/10S0R0J	—
NSP	210,211,213,214	R501,R502,R801,R802,R828	—	RS1/10S0R0J	—
NSP	212	R803,R304,R829,R854 -R856,R858-R860	—	RS1/10S0R0J	—
NSP	212	R875,R920,R922,R970 -R973,R8010	—	RS1/10S0R0J	—
NSP	212	R8200	—	RS1/10S0R0J	—
NSP		R202,R3510	—	RS1/10S101J	—
NSP	212	R839	—	RS1/16S103J	—
NSP	210,211,213,214	R2	—	RS1/16S103J	—
NSP	212	R2	—	RS1/16S223J	—
NSP	212	R1	—	RS1/16S333J	—
NSP	215	R1	—	RS1/16S103J	—
NSP		R700	—	RS1/10S1R2J	—
NSP	212	R836,R837	—	RS1/16S1001F	—
NSP		R807	—	RS1/16S1201F	—
NSP	212	R831,R832	—	RS1/16S1201F	—
NSP		R806	—	RS1/16S1501F	—
NSP		R363,R365	—	RS1/16S1503F	—
NSP	212	R825	—	RS1/16S1800F	—
NSP	212	R834,R385	—	RS1/16S1801F	—
NSP	210,211,213,214,215	R825	—	RS1/16S2000F	—
NSP	212	R822-R824	—	RS1/16S2000F	—
NSP		R826,R827	—	RS1/16S2000F	—
NSP	212	R830	—	RS1/16S2002F	—
NSP		R805	—	RS1/16S2701F	—
NSP	212	R833	—	RS1/16S3902F	—
NSP		R361,R364	—	RS1/16S6202F	—
NSP	215	R866	—	RS1/16S103J	—
NSP	215	R808	—	RS1/16S8202F	—
NSP	215	R822-R824	—	RS1/16S1200F	—
NSP	215	R845-R847	—	RS1/16S182J	—
NSP	215	R854,R856	—	RS1/16S4R7J	—
NSP	215	R855,R861-R865,R868-R871	—	RS1/16S0R0J	—
NSP	215	R971-R974,R8640	—	RS1/16S0R0J	—
NSP	215	R872	—	RS1/16S3001F	—
NSP	215	R873	—	RS1/16S6800F	—
NSP	215	R874	—	RS1/16S1201F	—
NSP	215	R8610,R8620,R8630	—	RS1/10S0R0J	—
NSP		Other Resistors	—	RS1/16SxxxJ	—

Mark	Ver. (DB-VPBxxx)	No.	Part No. (for PCS)	Description	Part No. (for MJI)
		OTHERS			
		CN4	9965 000 07984	DKN1193, FLEXIBLE CONNECTOR	*YJ002230R
		X2	9965 000 07985	DSS1110, CHIP CERAMIC LOCK (20MHz)	*FQ000450R
NSP		CN2	—	S2B-PH-SM3, PH CONNECTOR	—
NSP		CN1	—	S3B-PH-SM3, PH CONNECTOR	—
NSP		—	—	VDA1681, FLEXIBLE CABLE (07P)	—
NSP	210,212,213,215	CN15,CN5	—	VKN1516, CONNECTOR 30P	—
NSP	211,214	CN15,CN5	—	VKN1626, B TO B CONNECTOR 30P	—
NSP		CN3	—	VKN1763, 8P FFC CONNECTOR	—
NSP		—	—	VRW1773, BAR-CODE LABEL	—
		X1	9965 000 07986	VSS1147, CRYSTAL RESONATOR (13.824MHz)	*JX000700R
	210	—	—	VWS1446, DVDM Assy DB-VPB210	ZK402K0210
	211	—	—	VWS1449, DVDM Assy DB-VPB211	ZK324J0210
	212	—	9965 000 07628	VWS1447, DVDM Assy DB-VPB212	ZK402K0230
	213	—	—	VWS1448, DVDM Assy DB-VPB213	ZK402K0220
	214	—	—	VWS1450, DVDM Assy DB-VPB214	ZK324J0220
	215	—	—	VWS1451, DVDM Assy DB-VPB215	ZK408K0210