

# Service Manual

IR3000 /F1S

Wireless System

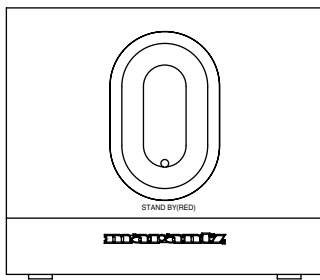

IR3000RX(L ch)

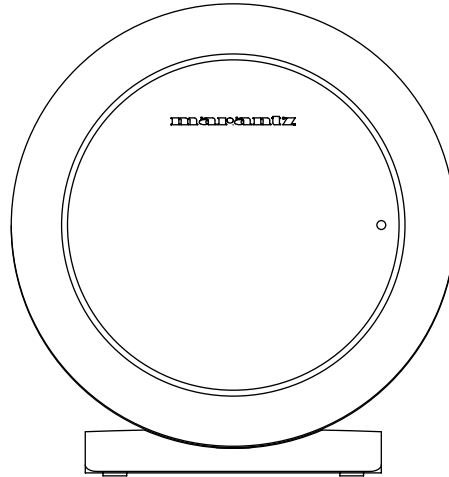

IR3000TX

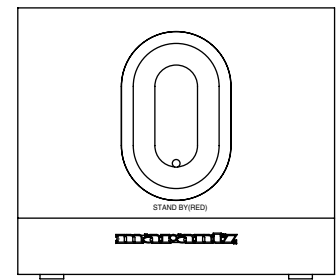

IR3000RX(R ch)

## TABLE OF CONTENTS

SECTION	PAGE
1. TECHNICAL SPECIFICATIONS .....	1
2. IC DATA .....	1
3. WIRING DIAGRAM .....	3
4. BLOCK DIAGRAM .....	5
5. SCHEMATIC DIAGRAM .....	9
6. PARTS LOCATION .....	15
7. EXPLODED VIEW AND PARTS LIST .....	20
8. ADJUSTMENT .....	22
9. ELECTRICAL PARTS LIST .....	24

Please use this service manual with referring to the user guide ( D.F.U. ) without fail.  
修理の際は、必ず取扱説明書を準備し操作方法を確認の上作業を行ってください。

# marantz®

## IR3000

## MARANTZ DESIGN AND SERVICE

Using superior design and selected high grade components, **MARANTZ** company has created the ultimate in stereo sound. Only original **MARANTZ** parts can insure that your **MARANTZ** product will continue to perform to the specifications for which it is famous.

Parts for your **MARANTZ** equipment are generally available to our National Marantz Subsidiary or Agent.

### ORDERING PARTS :

Parts can be ordered either by mail or by Fax.. In both cases, the correct part number has to be specified.

The following information must be supplied to eliminate delays in processing your order :

1. Complete address
2. Complete part numbers and quantities required
3. Description of parts
4. Model number for which part is required
5. Way of shipment
6. Signature : any order form or Fax. must be signed, otherwise such part order will be considered as null and void.

#### USA

**MARANTZ AMERICA, INC.**  
1100 MAPLEWOOD DRIVE  
ITASCA, IL. 60143  
USA  
PHONE : 630 - 741 - 0300  
FAX : 630 - 741 - 0301

#### EUROPE / TRADING

**MARANTZ EUROPE B.V.**  
P.O.BOX 80002, BUILDING SFF2  
5600 JB EINDHOVEN  
THE NETHERLANDS  
PHONE : +31 - 40 - 2732241  
FAX : +31 - 40 - 2735578

#### BRAZIL

**PHILIPS DA AMAZONIA IND. ELET. ITDA**  
CENTRO DE INFORMACOES AO  
CEP 04698-970  
SAO PAULO, SP, BRAZIL  
PHONE : 0800 - 123123(Discagem Direta Gratuita)  
FAX : +55 11 534. 8988

#### PROFESSIONAL AMERICAS

**SUPERSCOPE TECHNOLOGIES, INC.**  
MARANTZ PROFESSIONAL PRODUCTS  
2640 WHITE OAK CIRCLE, SUITE A  
AURORA, ILLINOIS 60504 USA  
PHONE : 630 - 820 - 4800  
FAX : 630 - 820 - 8103

#### PROFESSIONAL AUSTRALIA

**TECHNICAL AUDIO GROUP PTY, LTD**  
558 DARLING STREET,  
BALMAIN, NSW 2041,  
AUSTRALIA  
PHONE : 61 - 2 - 9810 - 5300  
FAX : 61 - 2 - 9810 - 5355

#### CANADA

**LENBROOK INDUSTRIES LIMITED**  
633 GRANITE COURT,  
PICKERING, ONTARIO L1W 3K1  
CANADA  
PHONE : 905 - 831 - 6333  
FAX : 905 - 831 - 6936

#### AUSTRALIA

**QualiFi Pty Ltd,**  
24 LIONEL ROAD,  
MT. WAVERLEY VIC 3149  
AUSTRALIA  
PHONE : +61 - (0)3 - 9543 - 1522  
FAX : +61 - (0)3 - 9543 - 3677

#### THAILAND

**MRZ STANDARD CO.,LTD**  
746 - 754 MAHACHAI ROAD.,  
WANGBURAPAPIROM, PHRANAKORN,  
BANGKOK, 10200 THAILAND  
PHONE : +66 - 2 - 222 9181  
FAX : +66 - 2 - 224 6795

#### SINGAPORE

**WO KEE HONG DISTRIBUTION PTE LTD**  
130 JOO SENG ROAD  
#03-02 OLIVINE BUILDING  
SINGAPORE 368357  
PHONE : +65 858 5535 / +65 381 8621  
FAX : +65 858 6078

#### NEW ZEALAND

**WILDASH AUDIO SYSTEMS NZ**  
14 MALVERN ROAD MT ALBERT  
AUCKLAND NEW ZEALAND  
PHONE : +64 - 9 - 8451958  
FAX : +64 - 9 - 8463554

#### TAIWAN

**PAI- YUING CO., LTD.**  
6 TH FL NO, 148 SUNG KIANG ROAD,  
TAIPEI, 10429, TAIWAN R.O.C.  
PHONE : +886 - 2 - 25221304  
FAX : +886 - 2 - 25630415

#### MALAYSIA

**WO KEE HONG ELECTRONICS SDN. BHD.**  
SUITE 8.1, LEVEL 8, MENARA GENESIS,  
NO. 33, JALAN SULTAN ISMAIL,  
50250 KUALA LUMPUR, MALAYSIA  
PHONE : +60 3 - 2457677  
FAX : +60 3 - 2458180

#### JAPAN *Technical*

**MARANTZ JAPAN, INC.**  
35- 1, 7- CHOME, SAGAMIONO  
SAGAMIHARA - SHI, KANAGAWA  
JAPAN 228-8505  
PHONE : +81 42 748 1013  
FAX : +81 42 741 9190

#### 日本マランツ株式会社

本社 〒228-8505  
神奈川県相模原市相模大野7-35-1  
営業本部 〒150-0022  
東京都渋谷区恵比寿南1-11-9

#### KOREA

**MK ENTERPRISES LTD.**  
ROOM 604/605, ELECTRO-OFFICETEL, 16-58,  
3GA, HANGANG-RO, YONGSAN-KU, SEOUL  
KOREA  
PHONE : +822 - 3232 - 155  
FAX : +822 - 3232 - 154

### SHOCK, FIRE HAZARD SERVICE TEST :

**CAUTION :** After servicing this appliance and prior to returning to customer, measure the resistance between either primary AC cord connector pins ( with unit NOT connected to AC mains and its Power switch ON ), and the face or Front Panel of product and controls and chassis bottom.

Any resistance measurement less than 1 Megohms should cause unit to be repaired or corrected before AC power is applied, and verified before it is return to the user/customer.

Ref. UL Standard No. 1492.

In case of difficulties, do not hesitate to contact the Technical Department at above mentioned address.

# 1. TECHNICAL SPECIFICATIONS

- 定格出力 25W ..... (100 Hz ~ 15 kHz , T.H.D 0.1 % , 負荷 6 Ω)
  - 実用最大出力..... 30 W (EIAJ)
  - 赤外線波長.....850 nm
  - 変調方式.....周波数変調
  - 搬送波周波数 (A/B)
  - 右チャンネル.....4.8 MHz
  - 左チャンネル.....3.8 MHz
  - 電源電圧.....AC100 V 50/60 Hz
  - 消費電力 (アンプ内蔵レシーバー : IR3000RX).....22 W
  - 最大外形寸法
  - トランスミッター (IR3000TX).....直径 150 mm × 奥行き 54 mm  
(トランスミッタースタンドを使用した場合 : 幅 150 mm × 高さ 159 mm × 奥行き 110 mm)
  - アンプ内蔵レシーバー (IR3000RX).....幅 107 mm × 高さ 91.5 mm × 奥行き 158 mm
  - 質量
  - トランスミッター (IR3000TX).....200 g
  - アンプ内蔵レシーバー (IR3000RX).....1.7 kg
- 仕様および外観は、改良のため、予告なく変更することがあります。

# 2. IC DATA

SA571 (COMPANDOR)  
BLOCK DIAGRAM

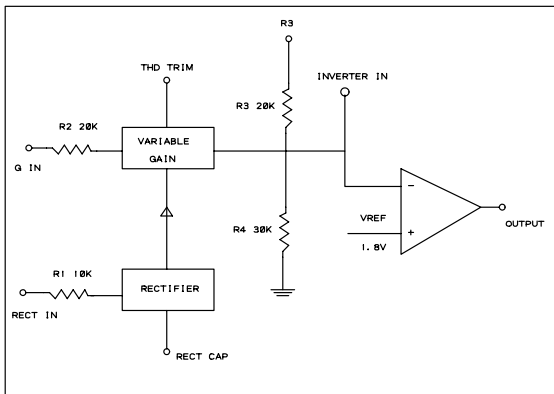

PIN COFIGURATION

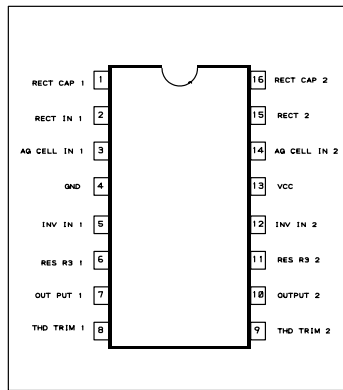

uPC1237 (PROTECTOR IC IC35 IC45)

BLOCK DIAGRAM

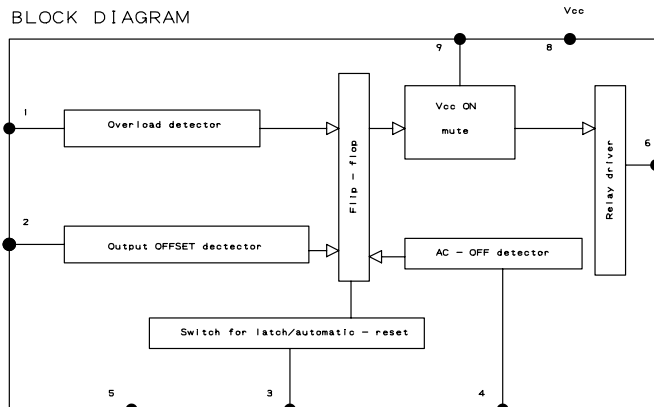

LA1235 (FM IF IC31 IC41)

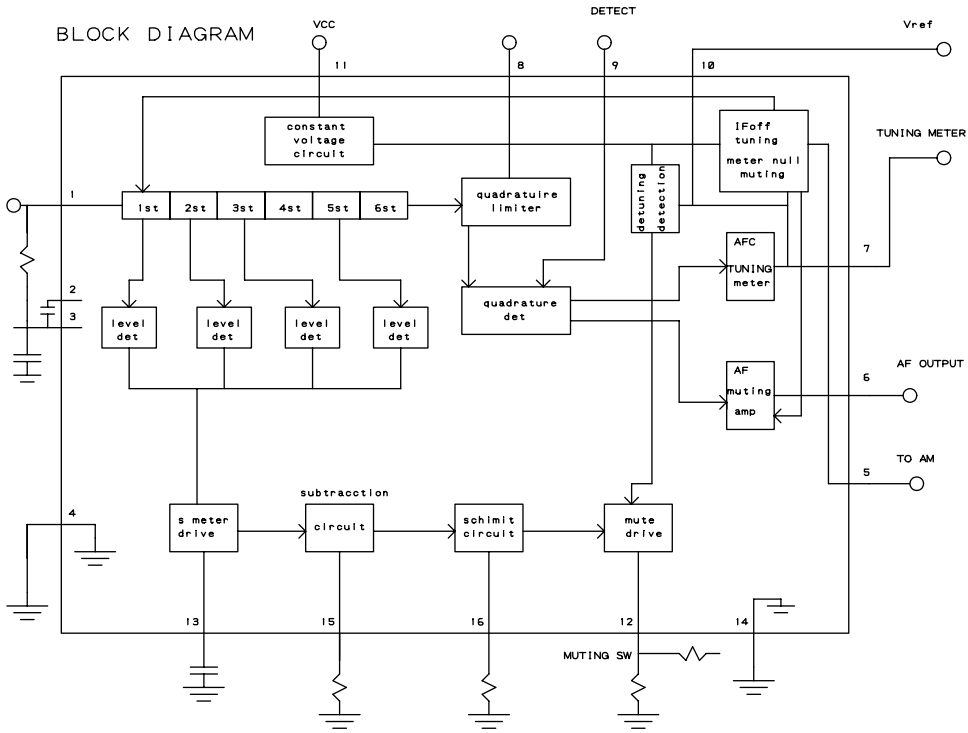

TDA2052 (POWER AMP IC36 IC46)

BLOCK DIAGRAM

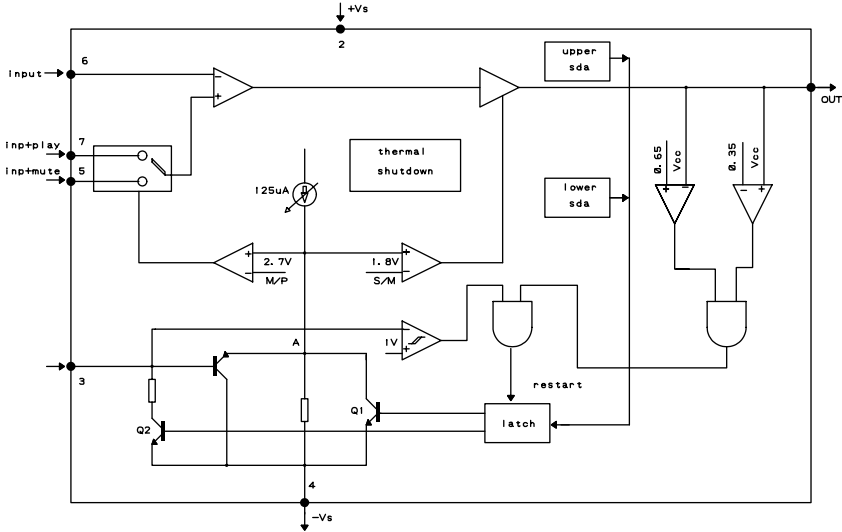

PIN CONNECTION

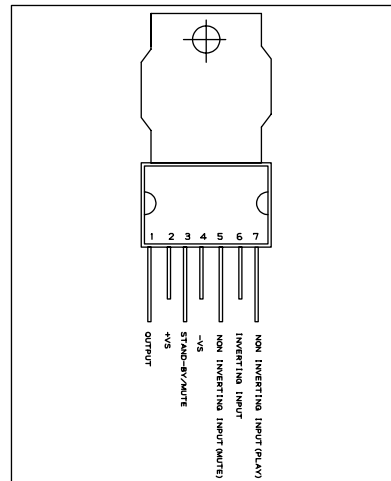

### 3. BLOCK DIAGRAM

TX UNIT

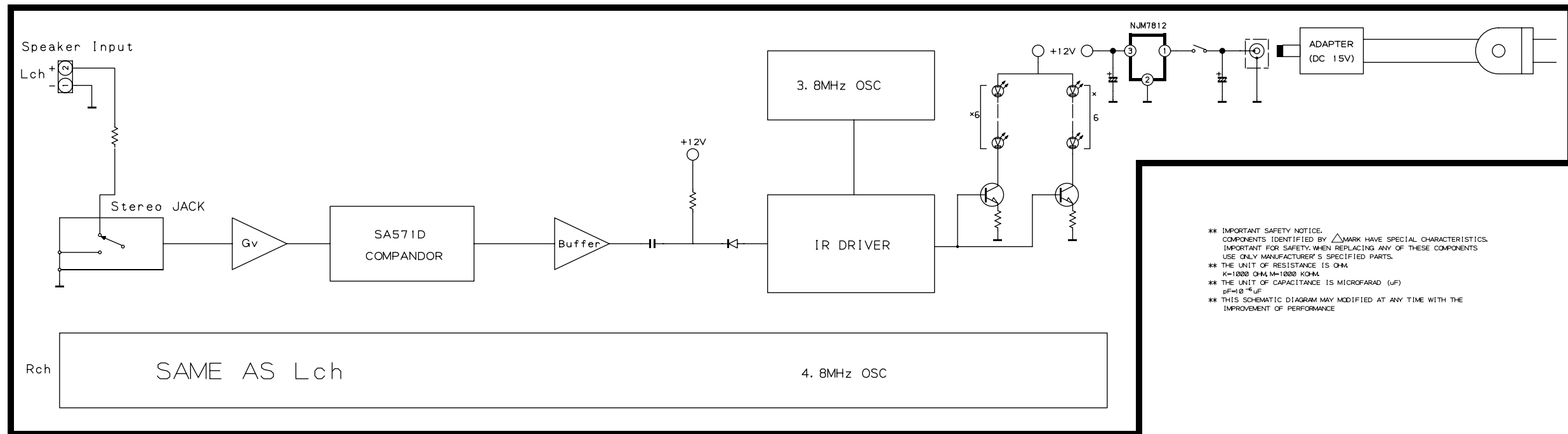

RX UNIT

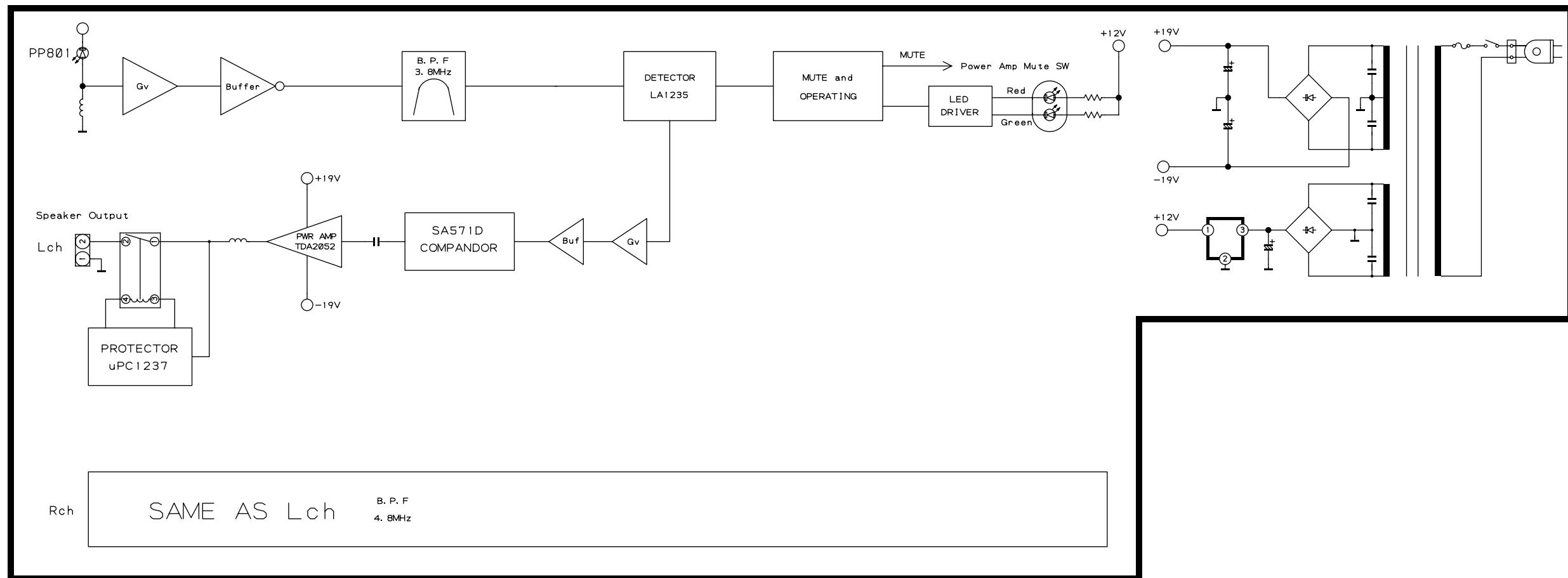

4. WIRING DIAGRAM

WIRING DIAGRAM (LCH)

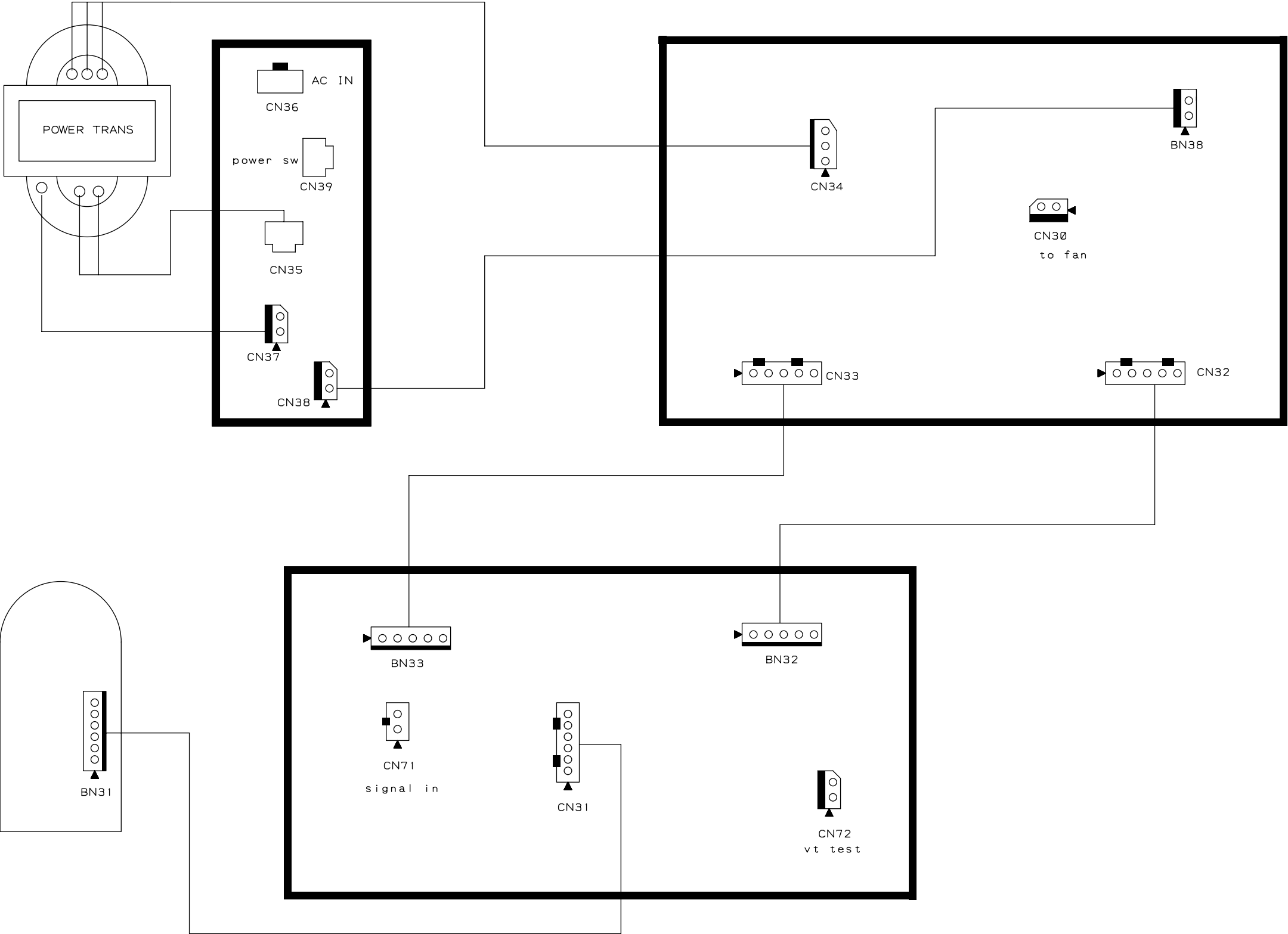

WIRING DIAGRAM (RCH)

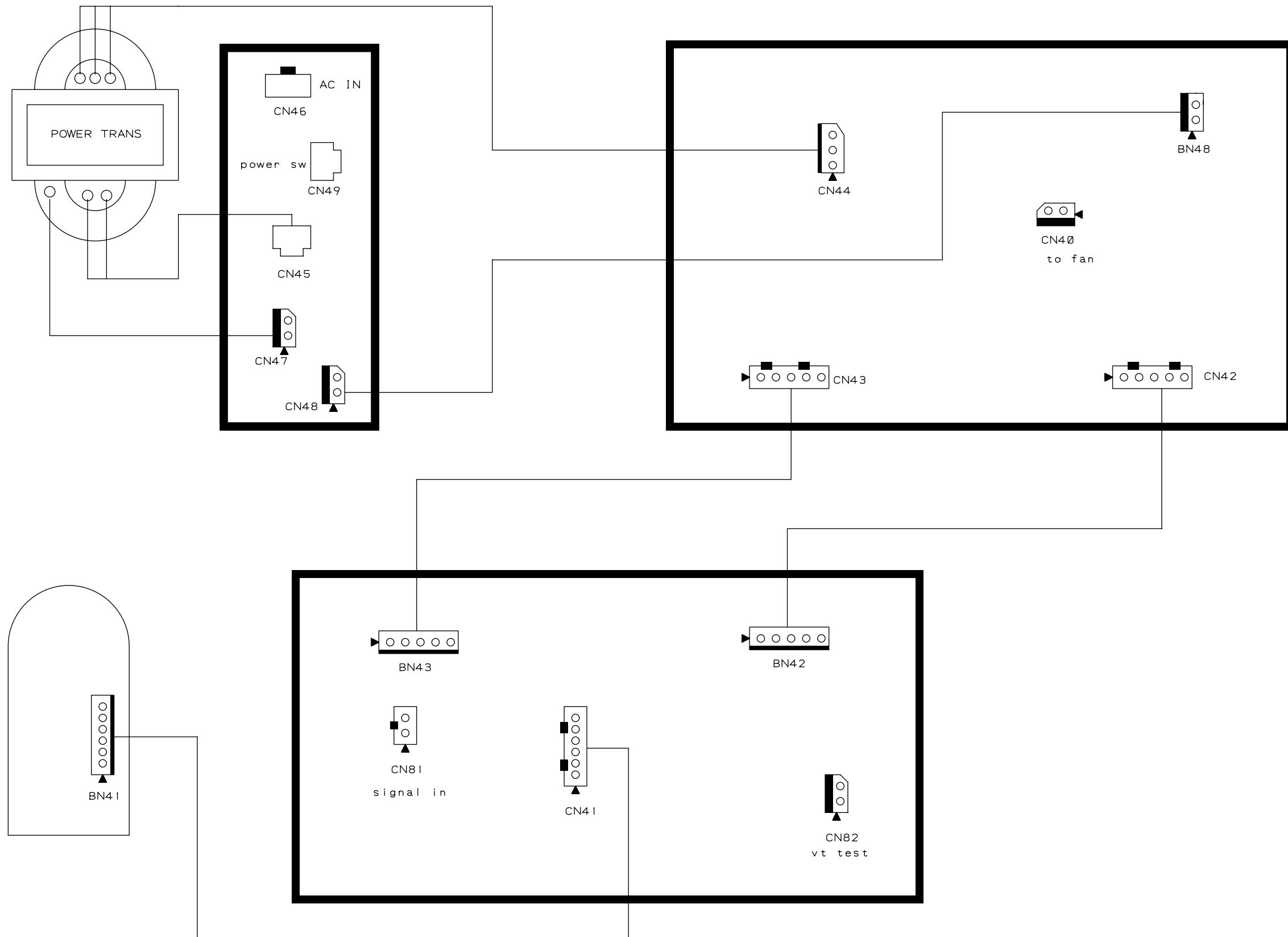

# 5. SCHEMATIC DIAGRAM

## IR3000RX (L CH)

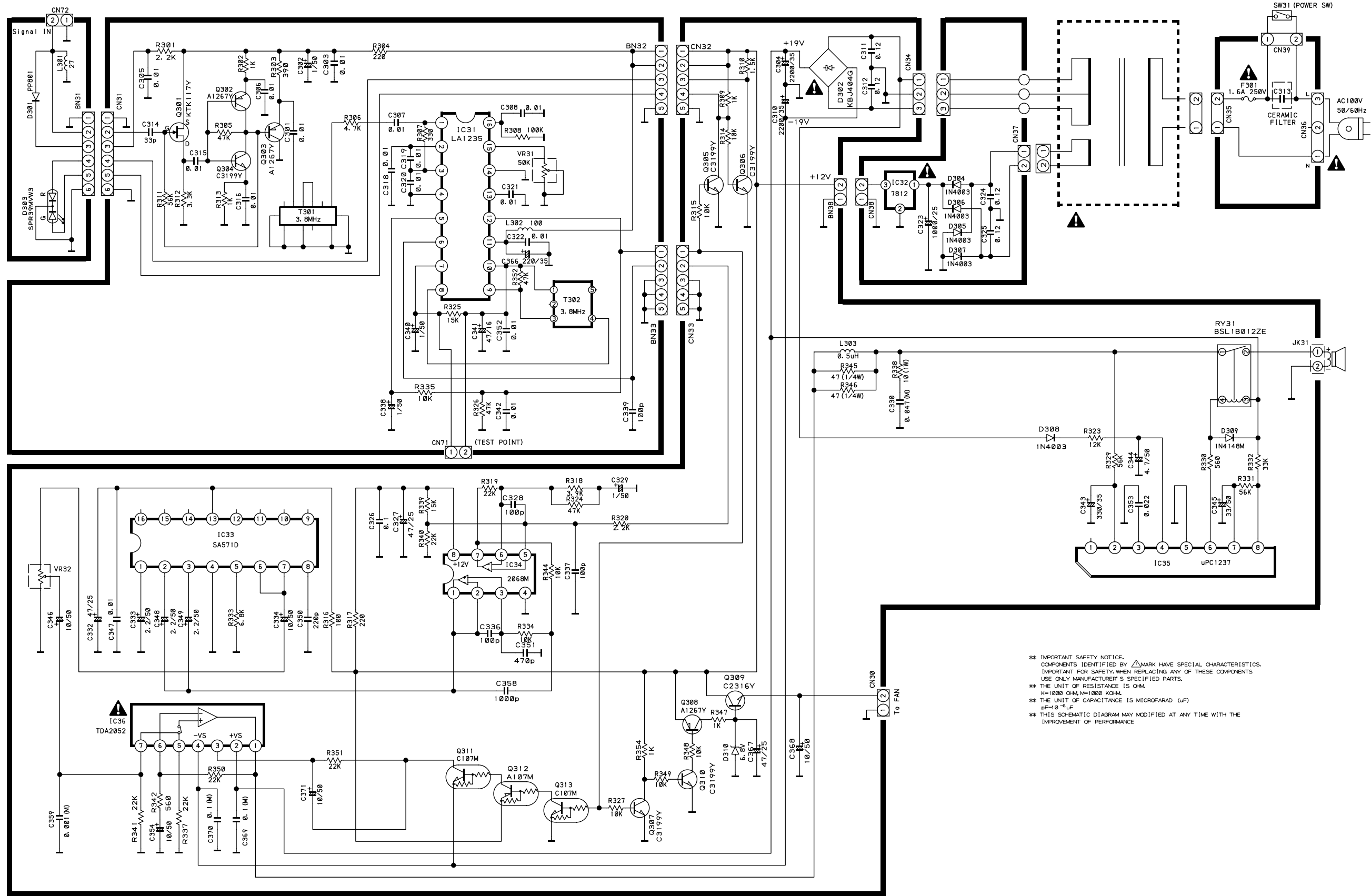



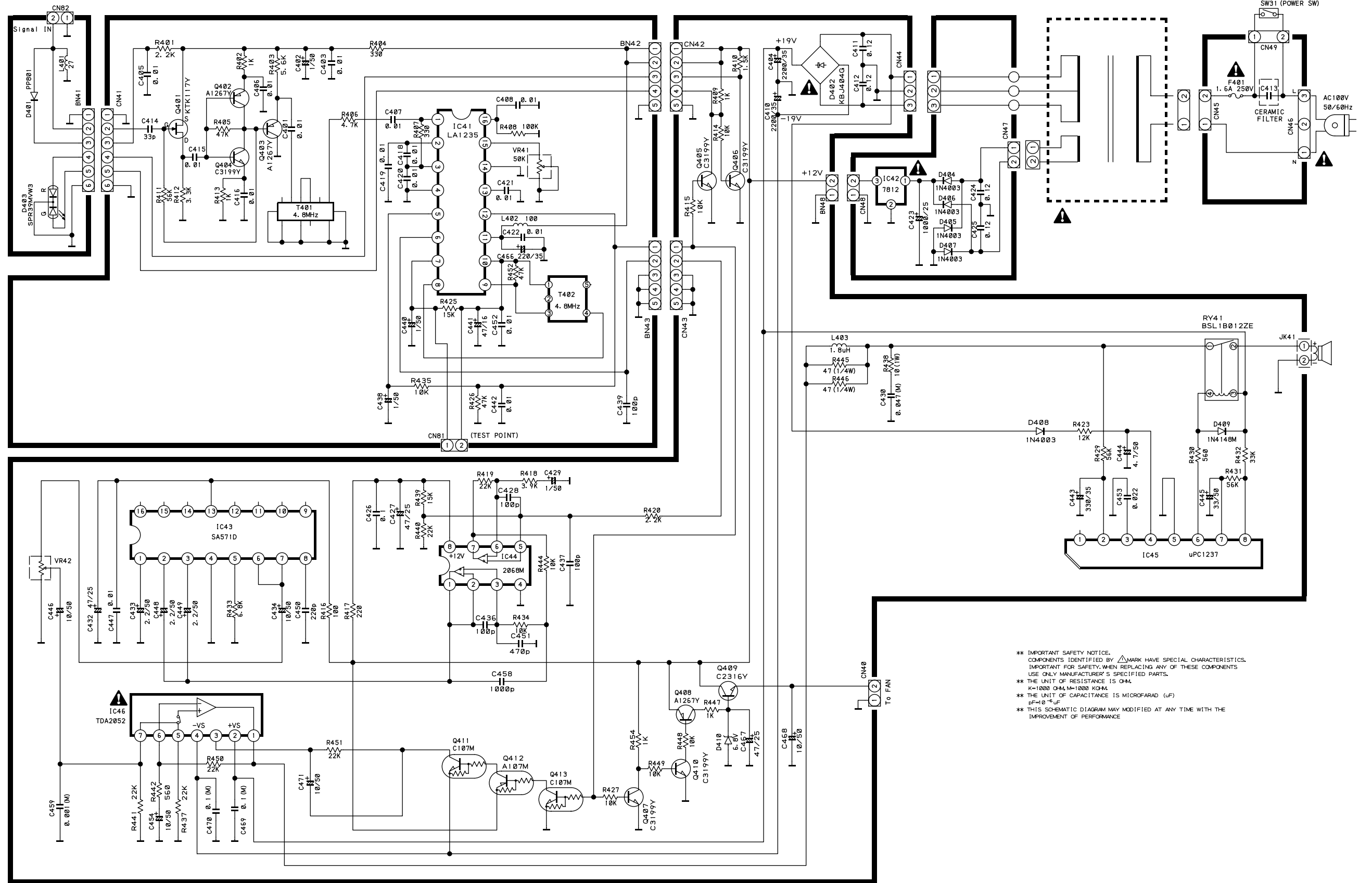

IR3000RX (R CH)

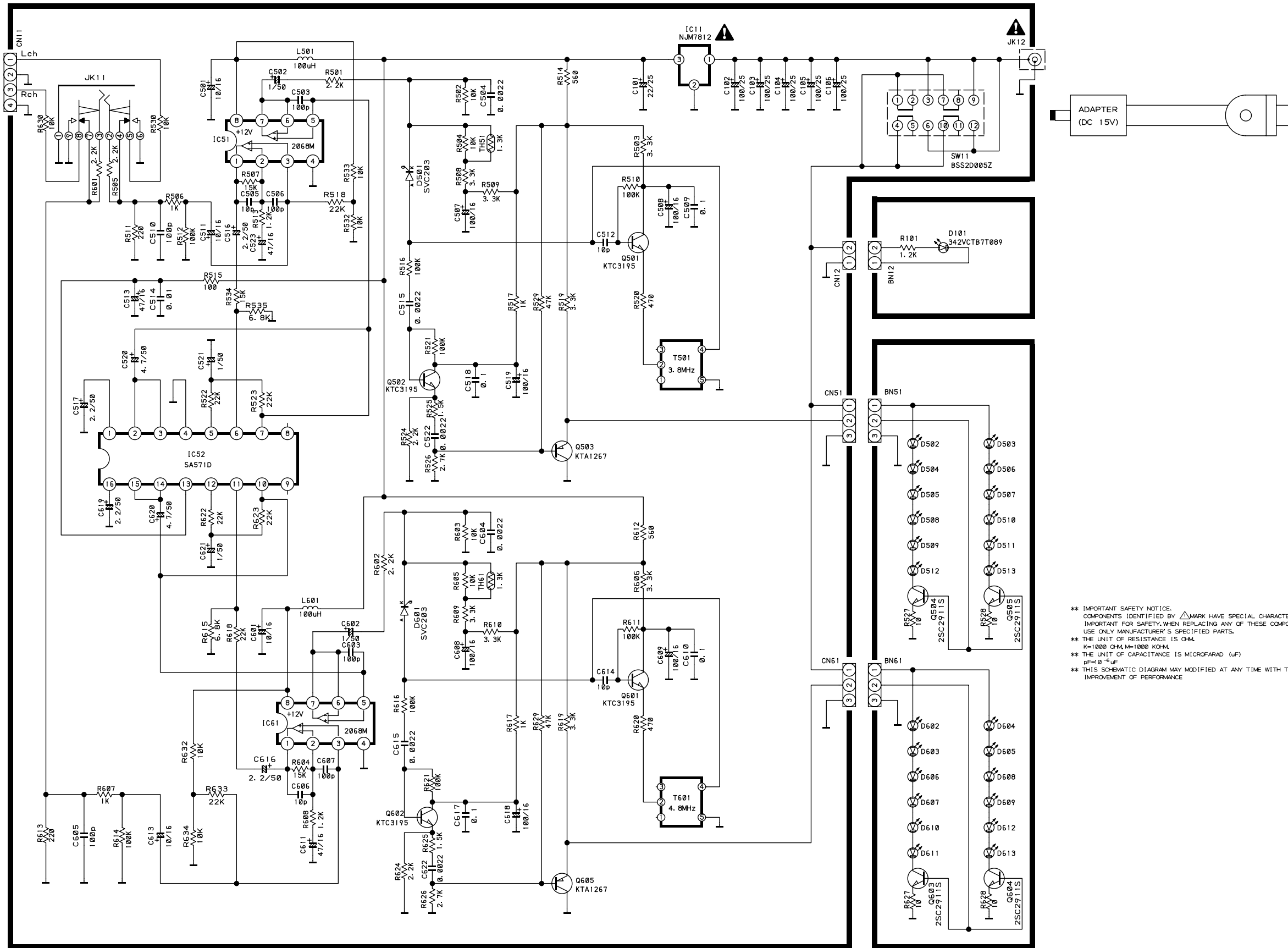

\*\* IMPORTANT SAFETY NOTICE.  
 COMPONENTS IDENTIFIED BY MARK HAVE SPECIAL CHARACTERISTICS.  
 IMPORTANT FOR SAFETY, WHEN REPLACING ANY OF THESE COMPONENTS  
 USE ONLY MANUFACTURER'S SPECIFIED PARTS.  
 \*\* THE UNIT OF RESISTANCE IS OHM.  
 K=1000 OHM, M=1000 KOHM.  
 \*\* THE UNIT OF CAPACITANCE IS MICROFARAD (uF)  
 pF=10<sup>-12</sup> uF  
 \*\* THIS SCHEMATIC DIAGRAM MAY MODIFIED AT ANY TIME WITH THE  
 IMPROVEMENT OF PERFORMANCE

IR3000TX



\*\* IMPORTANT SAFETY NOTICE.  
COMPONENTS IDENTIFIED BY  MARK HAVE SPECIAL CHARACTERISTICS.  
IMPORTANT FOR SAFETY, WHEN REPLACING ANY OF THESE COMPONENTS  
USE ONLY MANUFACTURER'S SPECIFIED PARTS.  
\*\* THE UNIT OF RESISTANCE IS OHM.  
K=1000 OHM=1000 KOHM  
\*\* THE UNIT OF CAPACITANCE IS MICROFARAD (uF)  
pF=10<sup>-12</sup>UF  
\*\* THIS SCHEMATIC DIAGRAM MAY MODIFIED AT ANY TIME WITH THE  
IMPROVEMENT OF PERFORMANCE

# 6. PARTS LOCATION

## TX PCB

Q502 Q503  
 Q601 Q510 IC52 IC61 Q602 IC11  
 Q605

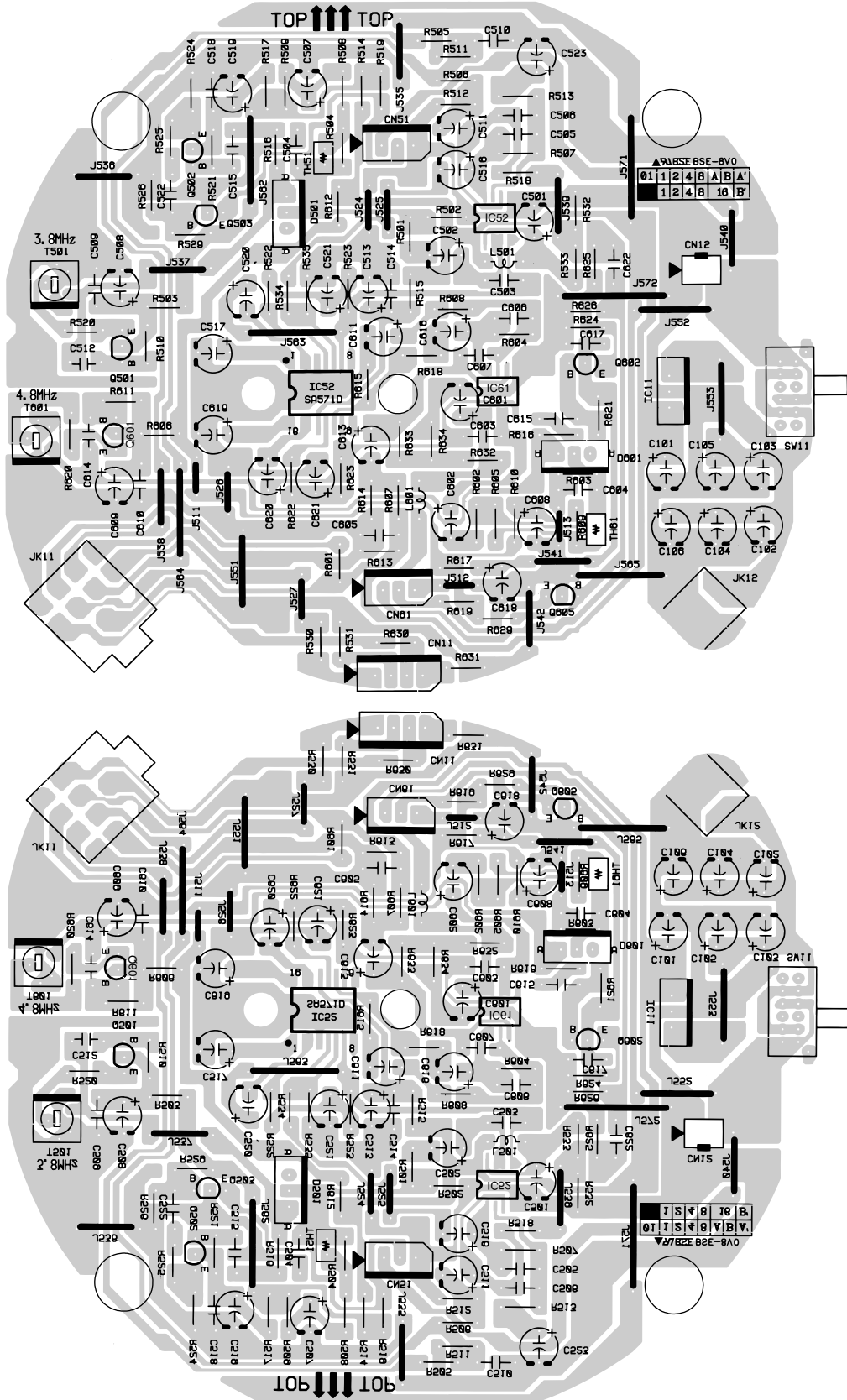



IC36 IC35 IC34  
 Q311 Q309 IC34  
 Q313 Q312 Q310 Q308 Q307 Q305 Q306

**RX LCH PCB**

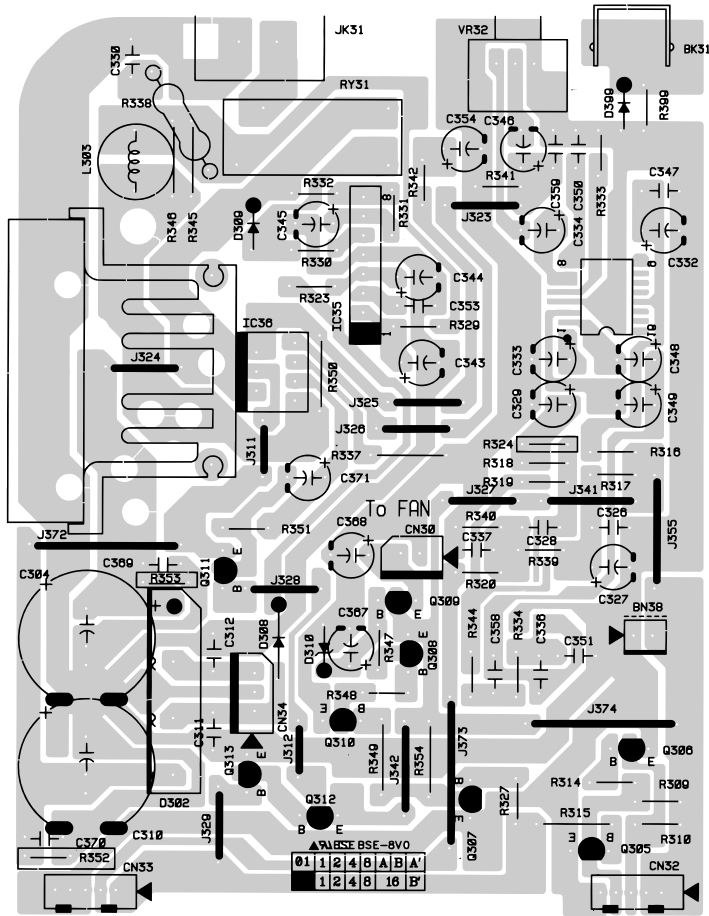

IC31  
 Q301 - Q304

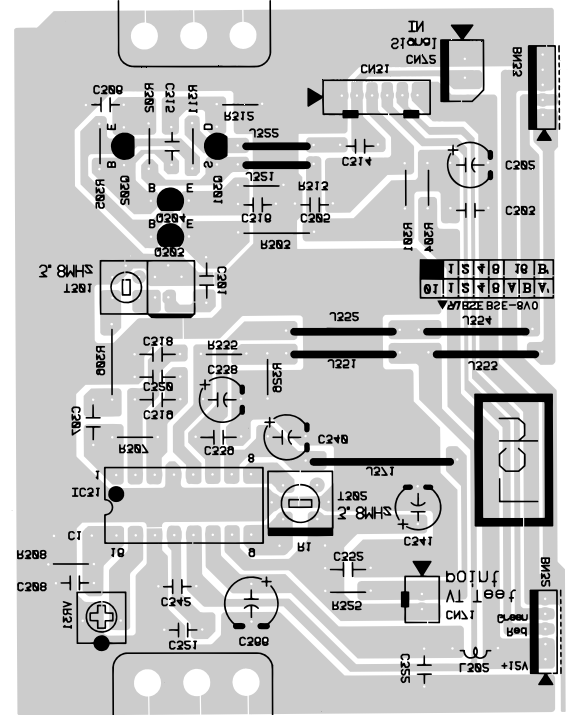
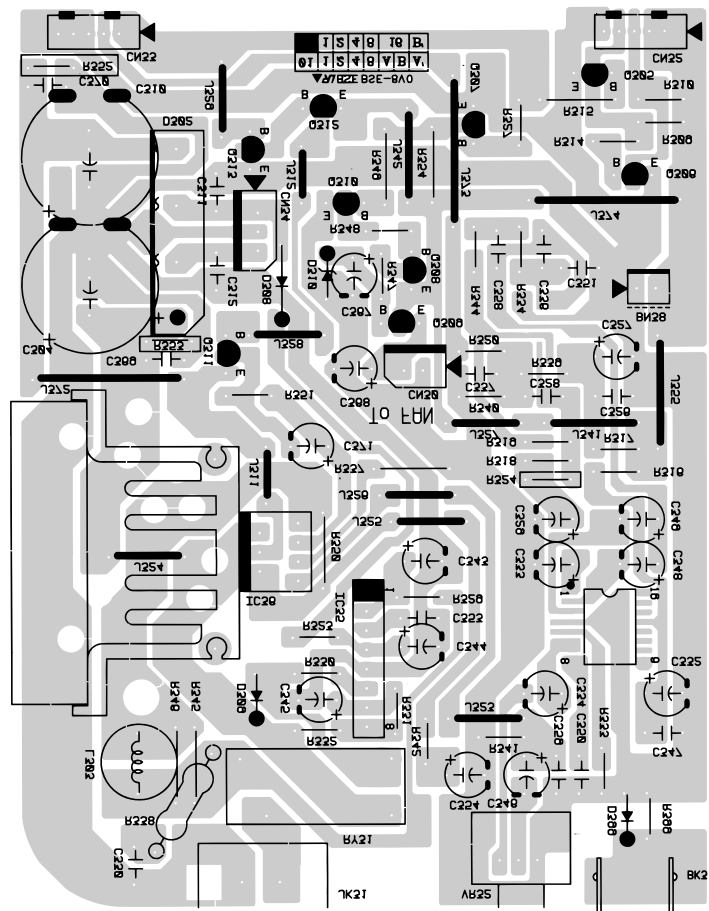
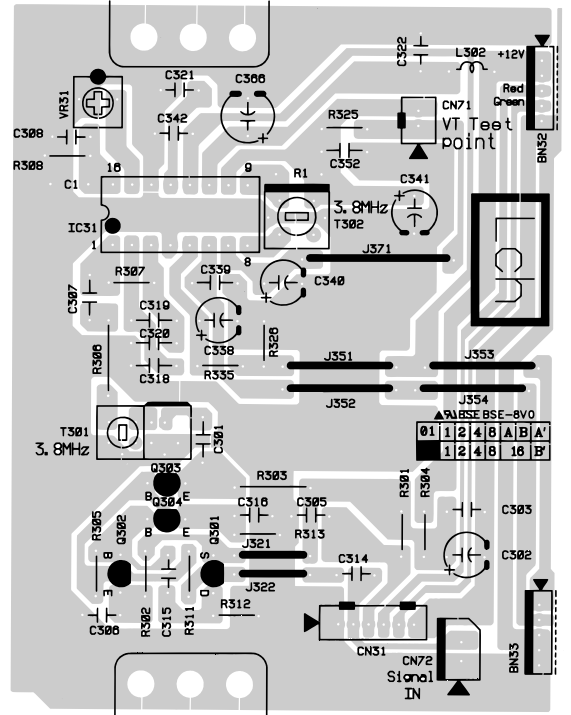

**RX LCH PCB**

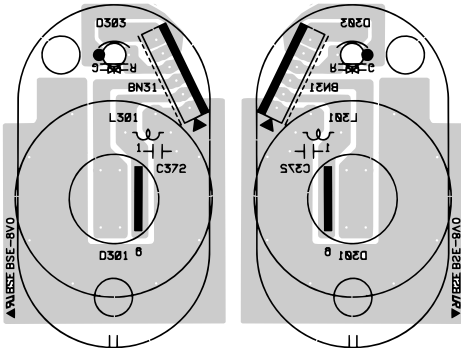

**RX RCH PCB**

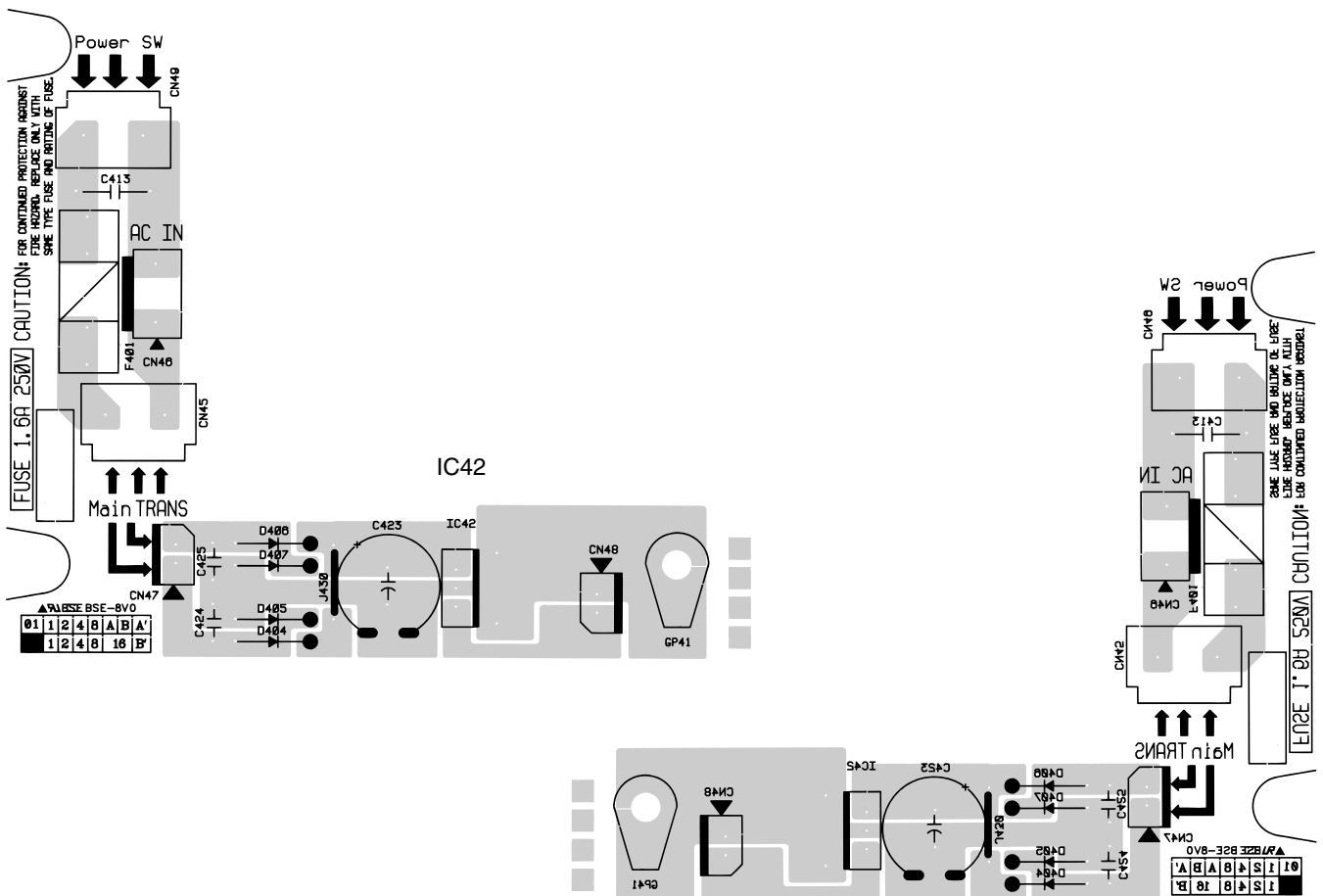
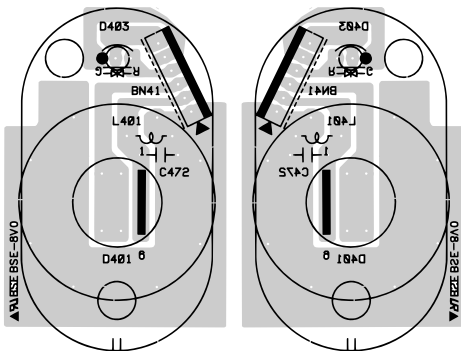

IC46 IC45 IC44  
 Q411 Q409 IC44  
 Q413 Q412 Q410 Q408 Q407 Q405 Q406

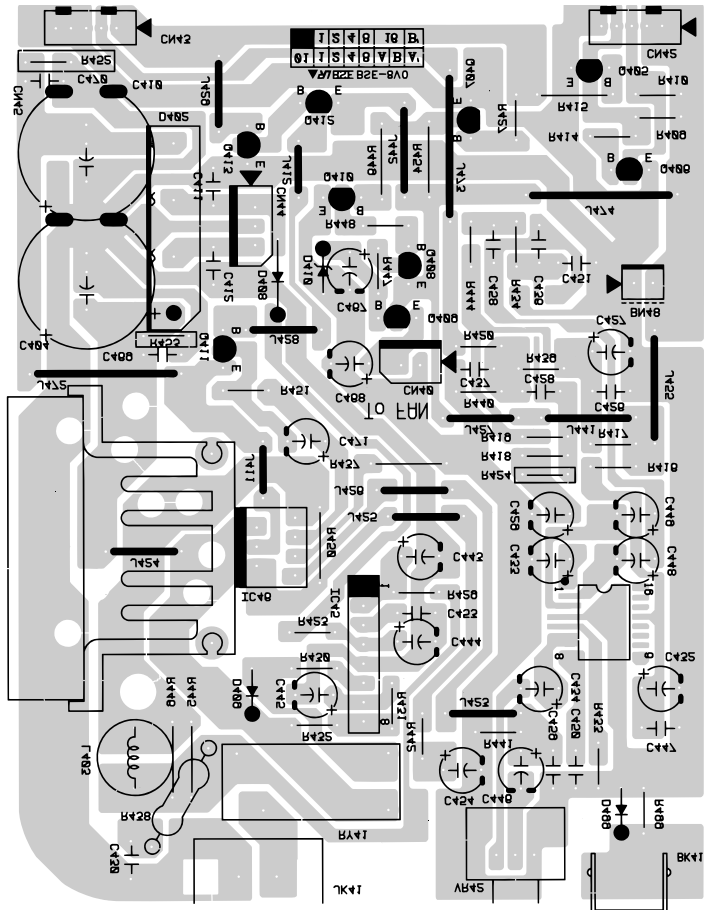
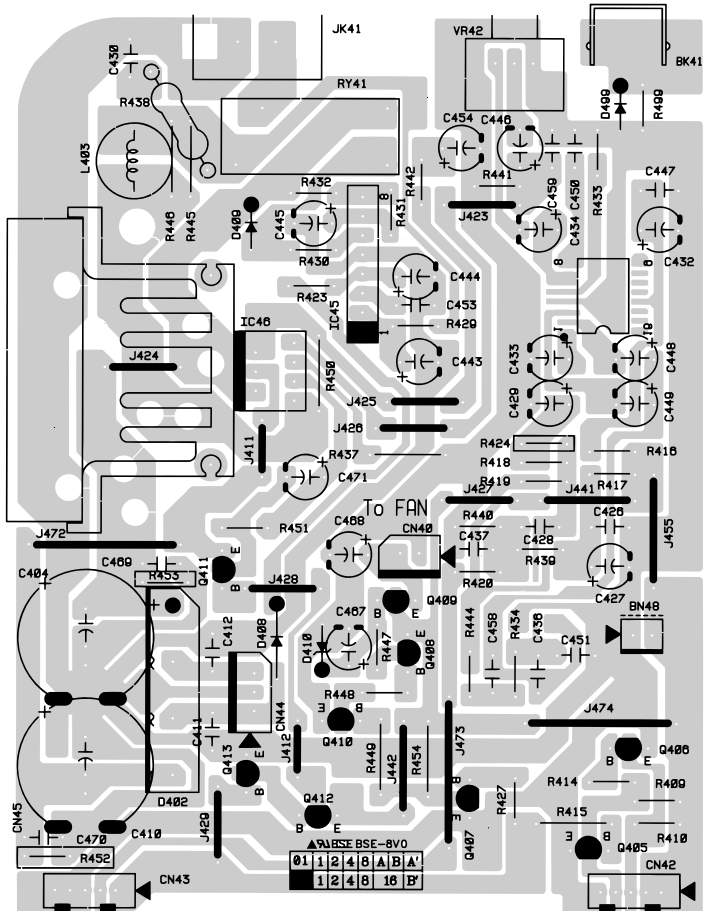

RX RCH PCB

IC41  
 Q401 - Q404

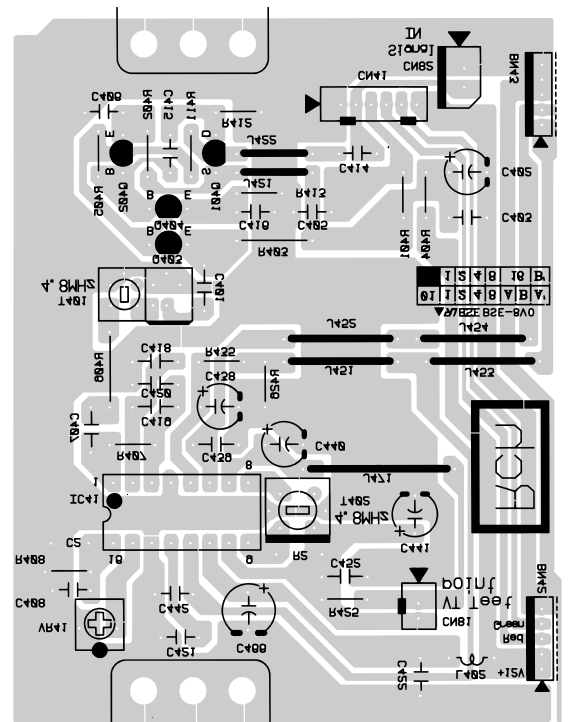
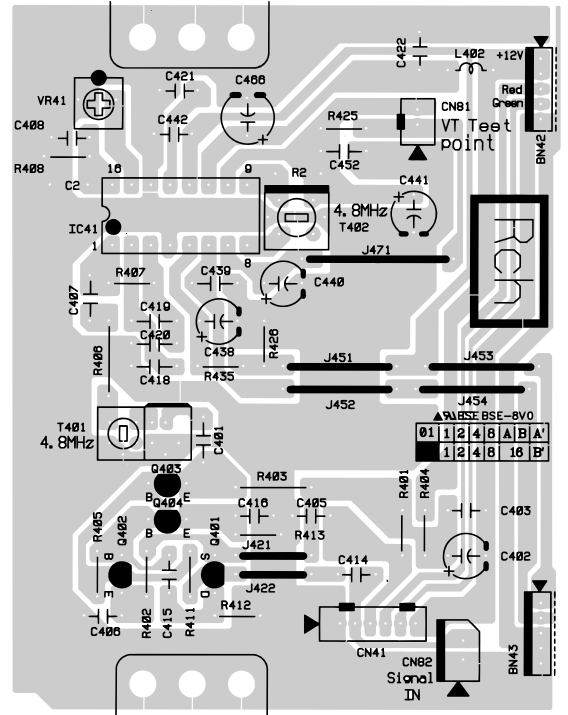

## 7. EXPLODED VIEW AND PARTS LIST

IR3000TX

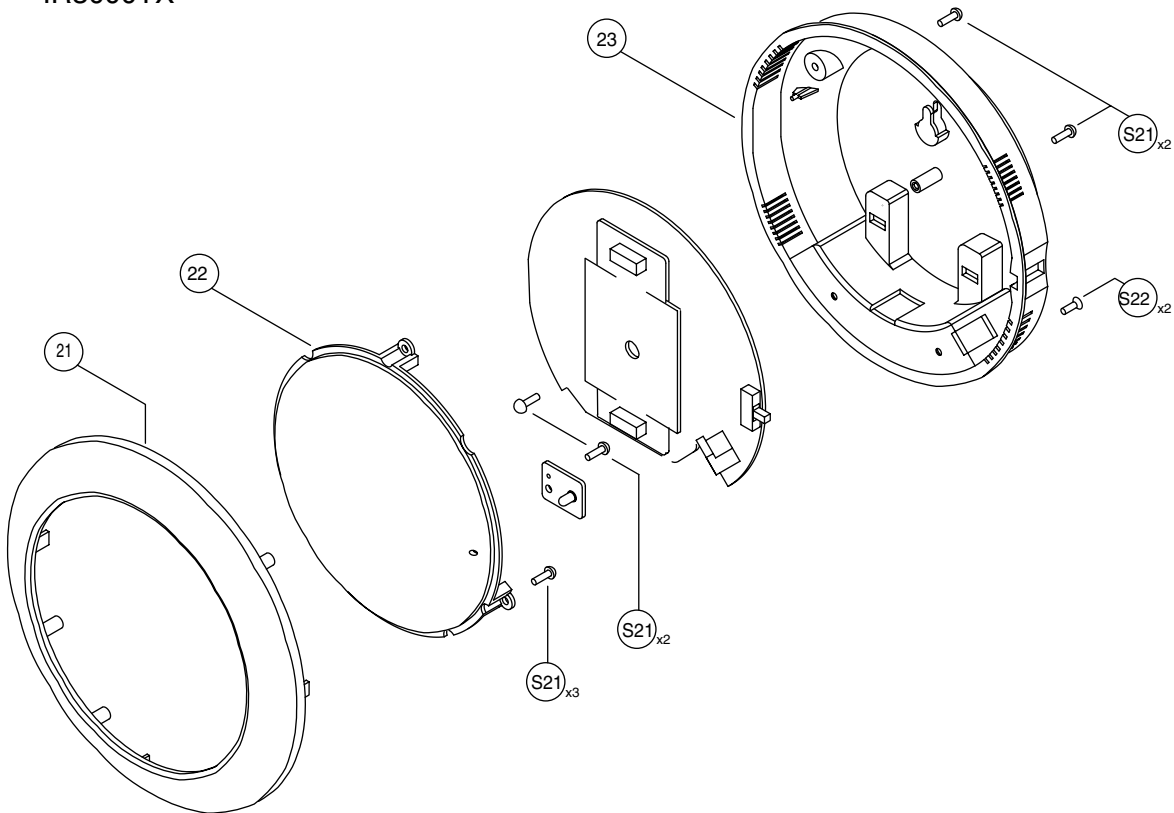

POS. NO	VERS. COLOR	DESCRIPTION	PART NO. (MJI)
		<b>MECHANICAL/ ELECTRICAL PART for IR3000TX (Transmitter)</b>	
21		KGR1A232M7K107 FRONT ORNAMENT	333W064010
22		KGU1A258A19Z DOME FILTER	333W053010
23		KGP1A019M7K107 BACK COVER	333W064020
S21		KTB26+8GFN SCREW	nsp
S22		KTS26+8JFN SCREW	nsp

NOTE : "nsp" PART IS LISTED FOR REFERENCE ONLY, MARANTZ WILL NOT SUPPLY THESE PARTS.



# IR3000RX

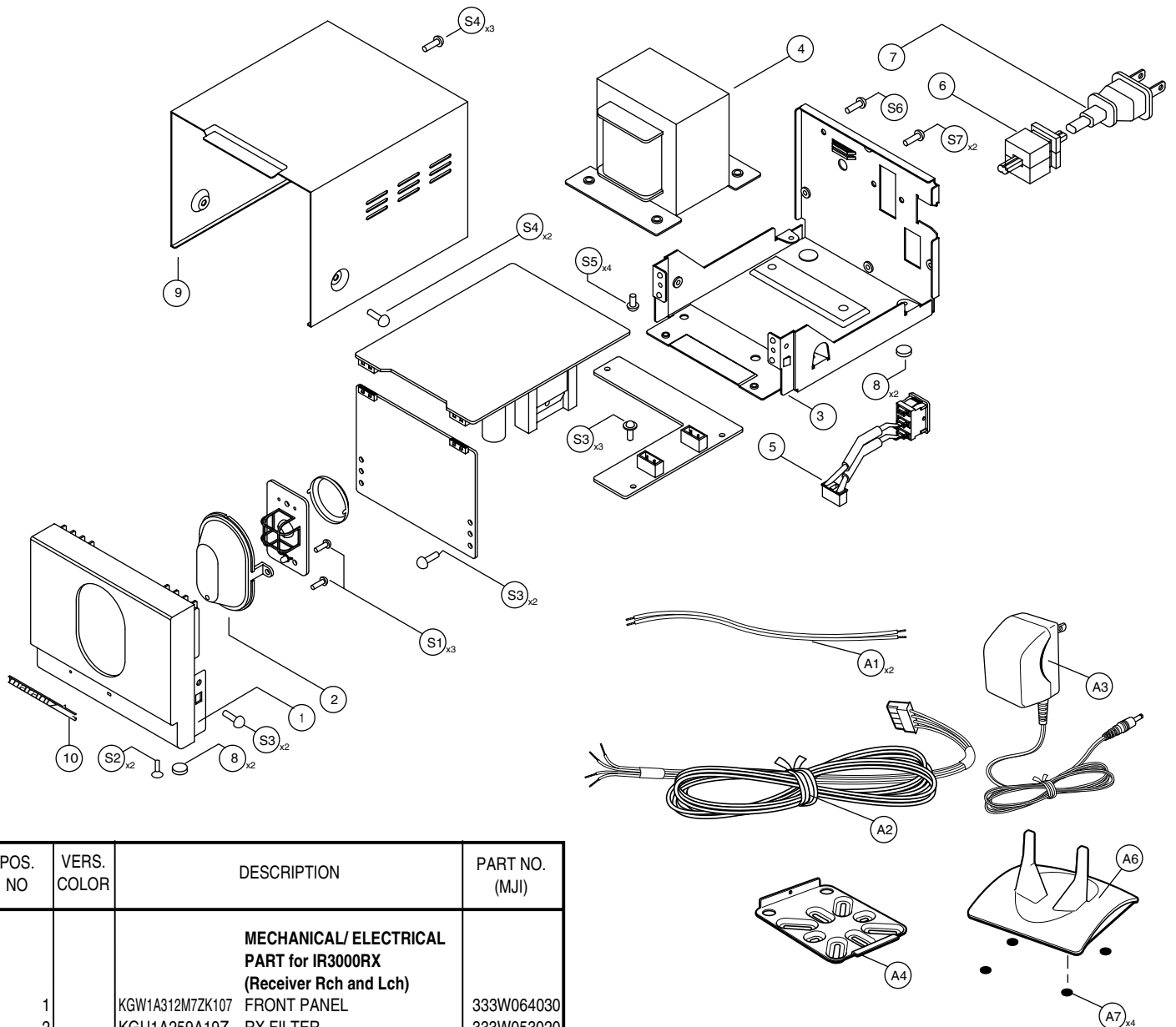

POS. NO	VERS. COLOR	DESCRIPTION	PART NO. (MJI)
<b>MECHANICAL/ ELECTRICAL PART for IR3000RX (Receiver Rch and Lch)</b>			
1		KGW1A312M7ZK107 FRONT PANEL	333W064030
2		KGU1A259A19Z RX FILTER	333W053020
3		KUA1A197Z MAIN CHASSIS	nsp
4		KLT5N024ZT TRANS POWER	*TS001470R
5		KWZIR3000SW31 POWER SWITCH ASS'Y	*ZZ001740R
6		KHR1A028 BUSHING AC CORD	400K259010
7		BJA2J049Z CORD POWER JAPAN (100V 7A)	*YC000520R
8		KHG1A188 FOOT	333W057010
9		KKC1A119K111 TOP COVER	333W257010
10		KGB1A085G MARANTZ BADGE	333W251010
S1		KTB26+8GFN SCREW	nsp
S2		KTS3+8JFN SCREW	nsp
S3		KTW3+8J SCREW	nsp
S4		KTBD3+8JFN SCREW	nsp
S5		KTB4+6F SCREW	nsp
S6		KTB3+8JFZ SCREW	nsp
S7		KTB3+10GFZ SCREW	nsp

POS. NO	VERS. COLOR	DESCRIPTION	PART NO. (MJI)
<b>PARKING Accessories for IR3000</b>			
A1		KWX1A031 CORD SPEAKER	nsp
A2		KWZIR3000BN11 WIRE ASS'Y for IR3000TX	*ZD000390R
A3		KJS3F001Z AC ADAPTOR AD90143A	*AA000020R
A4		KMD1A439K111 RX BRACKET( FOR IR3000RX)	333W160010
A5		KSB5+10N SCREW FOR RX BRACKET M5mm x 10mm	51100510E9
A6		KMH1A129M7K107 TX BASE(STAND FOR IR3000TX TRANSMITTER)	333W128010
A7		KHG1A188 FOOT( FOR TX BASE)	333W057010
A8		KQX1A687Z USER GUIDE	333W851110

NOTE : \*nsp\* PART IS LISTED FOR REFERENCE ONLY, MARANTZ WILL NOT SUPPLY THESE PARTS.

## 8. ADJUSTMENT

### RX LCH ADJUST METHODS

#### 1. Setting

Millivolt ammeter

S.S.G

3.8000 MHz

75 kHz (mod)

60 dB (EMF)

Connection

CN71, CN72

Adjust

T302, VR31

PCB

RX LCH BOARD PCB

#### 2. Adjust

1) AC 100V connection (power on)

2) S.S.G and CN72 connection

▷ Condition: mod 75 kHz (100 %)

EMF 60 dB

Freq' 3.8 MHz

3) Millivolt ammeter and CN71 connection

▷ Condition: range 50 mV

4) T302 3.8MHz Coil Adjust

▶ Millivolt ammeter ----> 0 mV ± 10 mV

5) S.S.G and CN72 connection

▷ Condition: mod 75 kHz (100 %)

EMF 24 dB

Freq' 3.8 MHz

6) VR31 Semi volume Adjust

▶ SPK OUT ----> MUTE ON Point

### RX RCH ADJUST METHODS

#### 1. Setting

Millivolt ammeter

S.S.G

4.8000 MHz

75 kHz (mod)

60 dB (EMF)

Connection

CN81, CN82

Adjust

T402, VR41

PCB

RX RCH BOARD PCB

#### 2. Adjust

1) AC 100V connection (power on)

2) S.S.G and CN82 connection

▷ Condition: mod 75 kHz (100 %)

EMF 60 dB

Freq' 3.8 MHz

3) Millivolt ammeter and CN81 connection

▷ Condition: range 50 mV

4) T402 4.8 MHz Coil Adjust

▶ Millivolt ammeter ----> 0 mV ± 10 mV

5) S.S.G and CN82 connection

▷ Condition: mod 75 kHz (100%)

EMF 24 dB

Freq' 4.8 MHz

6) VR41 Semi volume Adjust

▶ SPK OUT ----> MUTE ON Point

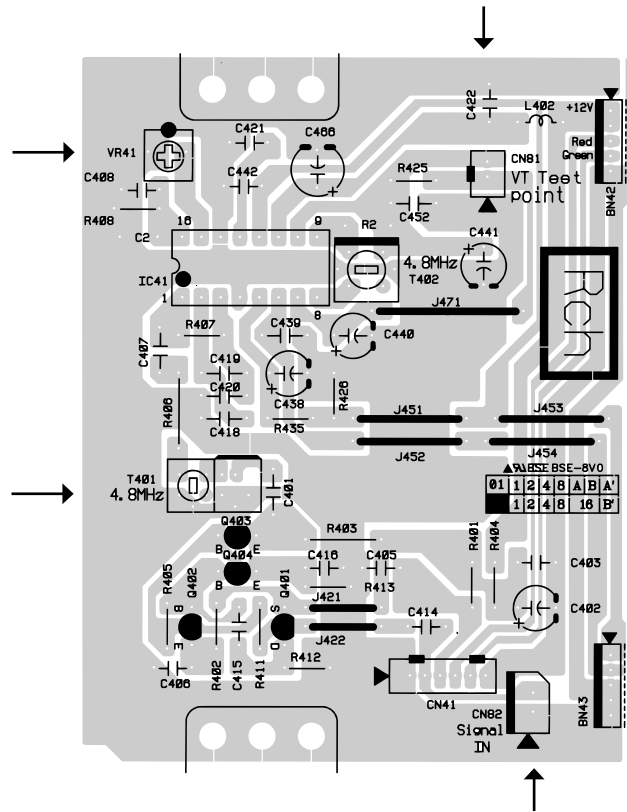
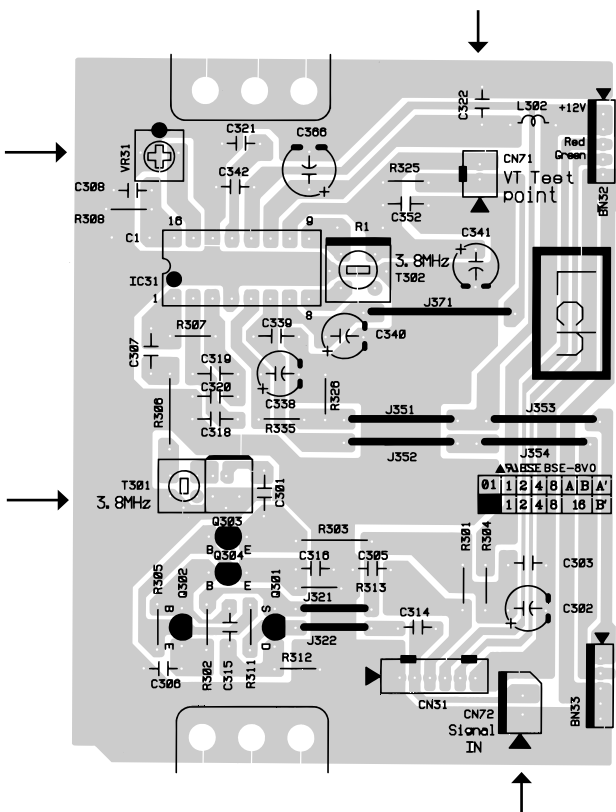

## TX PCB ADJUST METHODS

### 1. Setting

Frequency counter

OOOOOOOOMHz

Connection

Lch : J521, J510

Rch : J522, J523

Adjust

Lch : T501, Lch : T601

PCB

TX BOARD PCB

### 2. Adjust

1) AC adaptor connection (DC 12V)

2) Freq' counter connection (L ch)

J521 ----> +

J522 ----> -

3) T501 3.8MHz Coil Adjust

▶ Freq' counter ----> 3.8 MHz  $\pm$  10 kHz

4) Freq' counter connection (R ch)

J510 ----> +

J523 ----> -

5) T601 4.8 MHz Coil Adjust

▶ Freq' counter ----> 4.8 MHz  $\pm$  10 kHz

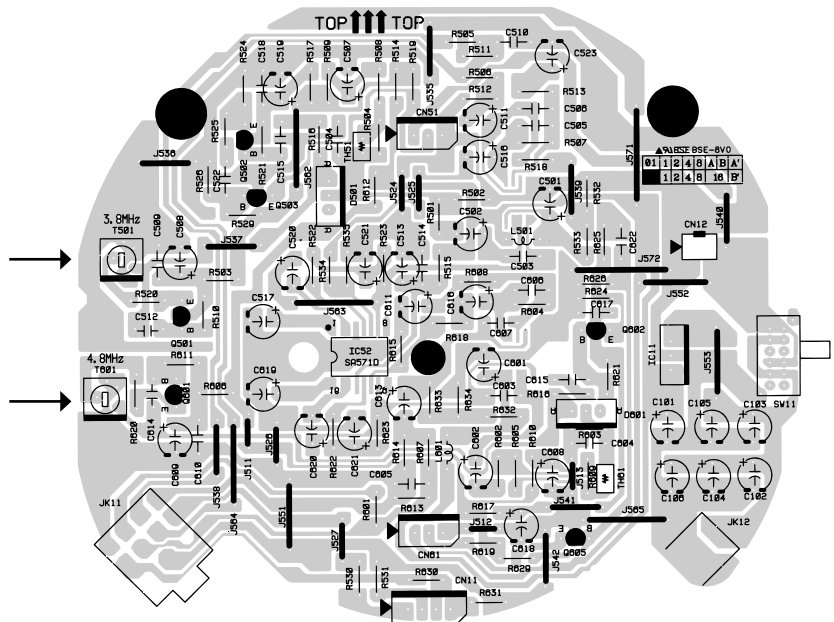
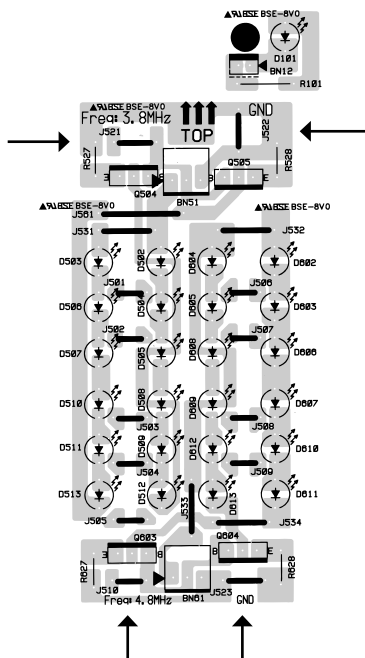

## 9. ELECTRICAL PARTS LIST

### ASSIGNMENT OF COMMON PARTS CODES.

#### RESISTORS

R\*\*\*: 1) GD05 × × × 140, Carbon film fixed resistor, ±5% 1/4W

R\*\*\*: 2) GD05 × × × 160, Carbon film fixed resistor, ±5% 1/6W

① — Resistance value

Examples ;

① Resistance value

0.1 Ω ... 001    10 Ω ... 100    1 kΩ ... 102    100 kΩ ... 104  
 0.5 Ω ... 005    18 Ω ... 180    2.7 kΩ ... 272    680 kΩ ... 684  
 1 Ω ... 010    100 Ω ... 101    10 kΩ ... 103    1 MΩ ... 105  
 6.8 Ω ... 068    390 Ω ... 391    22 kΩ ... 223    4.7 MΩ ... 475

Note : Please distinguish 1/4W from 1/6W by the shape of parts used actually.

#### CAPACITORS

C\*\*\*: CERAMIC CAP.

3) DD1 × × × × 370, Ceramic capacitor  
 Disc type  
 Temp.coeff.P350 ~ N1000, 50V  
 ② — Capacity value  
 ③ — Tolerance

Examples ;

② Tolerance (Capacity deviation)

±0.25 pF ... 0  
 ±0.5 pF ... 1  
 ±5% ... 5

\* Tolerance of COMMON PARTS handled here are as follows :

0.5 pF ~ 5 pF ... ±0.25 pF  
 6 pF ~ 10 pF ... ±0.5 pF  
 12 pF ~ 560 pF ... ±5%

③ Capacity value

0.5 pF ... 005    3 pF ... 030    100 pF ... 101  
 1 pF ... 010    10 pF ... 100    220 pF ... 221  
 1.5 pF ... 015    47 pF ... 470    560 pF ... 561

C\*\*\*: CERAMIC CAP.

4) DK16 × × × 300, High dielectric constant ceramic capacitor  
 Disc type  
 Temp.chara. 2B4, 50V  
 ④ — Capacity value

Examples ;

④ Capacity value

100 pF ... 101    1000 pF ... 102    10000 pF ... 103  
 470 pF ... 471    2200 pF ... 222

C\*\*\*: 5) ELECTROLY CAP. (  $\text{⏏}$  ), 6) FILM CAP. (  $\text{⏏}$  )

5) EA × × × × × 10, Electrolytic capacitor  
 One-way lead type, Tolerance ±20%  
 ⑤ — Capacity value  
 ⑥ — Working voltage

Examples ;

⑤ Capacity value

0.1 μF ... 104    4.7 μF ... 475    100 μF ... 107  
 0.33 μF ... 334    10 μF ... 106    330 μF ... 337  
 1 μF ... 105    22 μF ... 226    1100 μF ... 118  
 2200 μF ... 228

⑥ Working voltage

6.3V ... 006    25V ... 025  
 10V ... 010    35V ... 035  
 16V ... 016    50V ... 050

6) DF15 × × × 350 — Plastic film capacitor  
 DF15 × × × 310 — One-way type, Mylar ±5% 50V  
 DF16 × × × 310 — Plastic film capacitor  
 One-way type, Mylar ±10% 50V  
 ⑦ — Capacity value

Examples ;

⑦ Capacity value

0.001 μF (1000 pF) ..... 102    0.1 μF ... 104  
 0.0018 μF ..... 182    0.56 μF ... 564  
 0.01 μF ..... 103    1 μF ... 105  
 0.015 μF ..... 153

**NOTE** : 1) The above CODES ( R\*\*\*, R\*\*\*, C\*\*\*, C\*\*\* and C\*\*\* ) are omitted on the schematic diagram in some case.

2) On the occasion, be confirmed the common parts on the parts list.

3) Refer to "Common Parts List" for the other common parts (R105, DD4, DK4).

### NOTE ON SAFETY FOR FUSIBLE RESISTOR :

The suppliers and their type numbers of fusible resistors are as follows;

1. KOA Corporation

Part No. (MJI)	Type No. (KOA)	Description
NH05 × × × 140	RF25S × × × × ΩJ	(±5% 1/4W)
NH05 × × × 120	RF50S × × × × ΩJ	(±5% 1/2W)
NH85 × × × 110	RF73B2A × × × × ΩJ	(±5% 1/10W)
NH95 × × × 140	RF73B2E × × × × ΩJ	(±5% 1/4W)

\* Resistance value    Resistance value  
 (0.1 Ω – 10 kΩ)

2. Matsushita Electronic Components Co., Ltd

Part No. (MJI)	Type No. (MEC)	Description
NF05 × × × 140	ERD-2FCJ × × ×	(±5% 1/4W)
RF05 × × × 140	ERD-2FCG × × ×	(±2% 1/4W)
NF02 × × × 140		
RF02 × × × 140		

\* Resistance value    \* Resistance value

Examples ;

\* Resistance value

0.1 Ω ... 001    10 Ω ... 100    1 kΩ ... 102    100 kΩ ... 104  
 0.5 Ω ... 005    18 Ω ... 180    2.7 kΩ ... 272    680 kΩ ... 684  
 1 Ω ... 010    100 Ω ... 101    10 kΩ ... 103    1 MΩ ... 105  
 6.8 Ω ... 068    390 Ω ... 391    22 kΩ ... 223    4.7 MΩ ... 475

### ABBREVIATION AND MARKS

ANT. : ANTENNA	BATT. : BATTERY
CAP. : CAPACITOR	CER. : CERAMIC
CONN. : CONNECTING	DIG. : DIGITAL
HP : HEADPHONE	MIC. : MICROPHONE
μ-PRO : MICROPROCESSOR	REC. : RECORDING
RES. : RESISTOR	SPK : SPEAKER
SW : SWITCH	TRANSF. : TRANSFORMER
TRIM. : TRIMMING	TRS. : TRANSISTOR
VAR. : VARIABLE	X'TAL : CRYSTAL

### NOTE ON FUSE :

Regarding to all parts of parts code **FS20xxx2xx**, replace only with Wickmann-Werke GmbH, Type 372 non glass type fuse.

### NOTE ON SAFETY :

Symbol  $\blacktriangle$  Fire or electrical shock hazard. Only original parts should be used to replaced any part marked with symbol  $\blacktriangle$ . Any other component substitution (other than original type), may increase risk of fire or electrical shock hazard.

### 安全上の注意 :

$\blacktriangle$  がついている部品は、安全上重要な部品です。必ず指定されている部品番号の部品を使用して下さい。

POS. NO	VERS. COLOR	DESCRIPTION	PART NO. (MJJ)	POS. NO	VERS. COLOR	DESCRIPTION	PART NO. (MJJ)	
		<b>PCB Assy for IR3000RX (Receiver Lch)</b>						
		KUP11446Z	nsp	L301		KLQ02C270JT	COIL AXAIL 27μHJ	nsp
C301		KCBS1H103ZFT	nsp	L302		KLQ02C101JT	COIL AXAIL 100μHJ	nsp
C302		KCEA1HH1R0T	OA10505020	Q301		KVTKTK117YT	F.E.T KTK117Y	*HF200280R
C303		KCKT1H103ZF	nsp	Q302		KVTKTA1267YT	T.R KTA1267Y	*HT100550R
C305		KCKT1H103ZF	nsp	Q303		KVTKTA1267YT	T.R KTA1267Y	*HT100550R
C306		KCKT1H103ZF	nsp	Q304		KVTKTC3199YT	T.R KTC3199Y	*HT300840R
C307		KCBS1H103ZFT	nsp	Q305		KVTKTC3199YT	T.R KTC3199Y	*HT300840R
C308		KCKT1H103ZF	nsp	Q306		KVTKTC3199YT	T.R KTC3199Y	*HT300840R
C311		KCFE1J124JBT	nsp	Q307		KVTKTC3199YT	T.R KTC3199Y	*HT300840R
C312		KCFE1J124JBT	nsp	Q308		KVTKTA1267YT	T.R KTA1267Y	*HT100550R
C314		KCCT1H330JC	nsp	Q309		KVTKSC2316YT	T.R KSC2316Y	*HT300580R
C315		KCKT1H103ZF	nsp	Q310		KVTKTC3199YT	T.R KTC3199Y	*HT300840R
C316		KCKT1H103ZF	nsp	Q311		KVTKRC107MT	T.R KRC107M	*BA001070R
C318		KCBS1H103ZFT	nsp	Q312		KVTKRA107MT	T.R KRA107M	*BA001060R
C319		KCBS1H103ZFT	nsp	Q313		KVTKRC107MT	T.R KRC107M	*BA001070R
C320		KCBS1H103ZFT	nsp	R301		KRD20TJ222T	RES. CARBON 2.2kΩ 1/5W J	nsp
C321		KCKT1H103ZF	nsp	R302		KRD20TJ102T	RES. CARBON 1kΩ 1/5W J	nsp
C322		KCKT1H103ZF	nsp	R303		KRD25TJ221T	RES. CARBON 220Ω 1/4W J	nsp
C324		KCFE1J124JBT	nsp	R304		KRD20TJ331T	RES. CARBON 330Ω 1/5W J	nsp
C325		KCFE1J124JBT	nsp	R305		KRD20TJ473T	RES. CARBON 47kΩ 1/5W J	nsp
C326		KCKT1H104ZF	nsp	R306		KRD25TJ472T	RES. CARBON 4.7kΩ 1/4W J	nsp
C327		KCEA1EH470T	OA47601020	R307		KRD20TJ331T	RES. CARBON 330Ω 1/5W J	nsp
C328		KCKT1H101KB	nsp	R308		KRD20TJ104T	RES. CARBON 100kΩ 1/5W J	nsp
C329		KCEA1HH1R0T	OA10505020	R309		KRD20TJ102T	RES. CARBON 1kΩ 1/5W J	nsp
C330		KCQI1H473JZT	nsp	R310		KRD20TJ152T	RES. CARBON 1.5kΩ 1/5W J	nsp
C332		KCEA1EH470T	OA47601020	R311		KRD20TJ563T	RES. CARBON 56kΩ 1/5W J	nsp
C333		KCEA1HH2R2T	OA22505020	R312		KRD20TJ332T	RES. CARBON 3.3kΩ 1/5W J	nsp
C334		KCEA1HH100T	OA10605020	R313		KRD20TJ102T	RES. CARBON 1kΩ 1/5W J	nsp
C336		KCKT1H101KB	nsp	R314		KRD20TJ103T	RES. CARBON 10kΩ 1/5W J	nsp
C337		KCKT1H101KB	nsp	R315		KRD25TJ103T	RES. CARBON 10kΩ 1/4W J	nsp
C338		KCEA1HKS1R0T	nsp	R316		KRD20TJ101T	RES. CARBON 100Ω 1/5W J	nsp
C339		KCBS1H101KBT	nsp	R317		KRD20TJ221T	RES. CARBON 220Ω 1/5W J	nsp
C340		KCEA1HKS1R0T	nsp	R318		KRD20TJ392T	RES. CARBON 3.9kΩ 1/5W J	nsp
C341		KCEA1CKS470T	nsp	R319		KRD20TJ223T	RES. CARBON 22kΩ 1/5W J	nsp
C342		KCKT1H103ZF	nsp	R320		KRD20TJ222T	RES. CARBON 2.2kΩ 1/5W J	nsp
C344		KCEA1HH100T	OA10605020	R323		KRD20TJ123T	RES. CARBON 12kΩ 1/5W J	nsp
C345		KCEA1HH330T	nsp	R324		KRD20TJ473T	RES. CARBON 47kΩ 1/5W J	nsp
C346		KCEA1HH100T	OA10605020	R325		KRD20TJ153T	RES. CARBON 15kΩ 1/5W J	nsp
C347		KCKT1H103ZF	nsp	R326		KRD20TJ473T	RES. CARBON 47kΩ 1/5W J	nsp
C348		KCEA1HH2R2T	OA22505020	R327		KRD20TJ103T	RES. CARBON 10kΩ 1/5W J	nsp
C349		KCEA1HH2R2T	OA22505020	R329		KRD20TJ563T	RES. CARBON 56kΩ 1/5W J	nsp
C350		KCKT1H221KB	nsp	R330		KRD20TJ561T	RES. CARBON 560Ω 1/5W J	nsp
C351		KCKT1H471KB	nsp	R331		KRD20TJ563T	RES. CARBON 56kΩ 1/5W J	nsp
C352		KCBS1H103ZFT	nsp	R332		KRD20TJ333T	RES. CARBON 33kΩ 1/5W J	nsp
C353		KCKT1H223ZF	nsp	R333		KRD20TJ682T	RES. CARBON 6.8kΩ 1/5W J	nsp
C354		KCEA1HH100T	OA10605020	R334		KRD20TJ103T	RES. CARBON 10kΩ 1/5W J	nsp
C358		KCKT1H102KB	nsp	R335		KRD20TJ103T	RES. CARBON 10kΩ 1/5W J	nsp
C359		KCQI1H102JZT	nsp	R337		KRD25TJ223T	RES. CARBON 22kΩ 1/4W J	nsp
C366		KCEA1EH221T	nsp	R339		KRD20TJ153T	RES. CARBON 15kΩ 1/5W J	nsp
C367		KCEA1EH470T	OA47601020	R340		KRD20TJ223T	RES. CARBON 22kΩ 1/5W J	nsp
C368		KCEA1HH100T	OA10605020	R341		KRD20TJ223T	RES. CARBON 22kΩ 1/5W J	nsp
C369		KCQI1H104JZT	nsp	R342		KRD20TJ561T	RES. CARBON 560Ω 1/5W J	nsp
C370		KCQI1H104JZT	nsp	R344		KRD20TJ103T	RES. CARBON 10kΩ 1/5W J	nsp
C371		KCEA1HH100T	OA10605020	R345		KRD25TJ470T	RES. CARBON 47Ω 1/4W J	nsp
D304		KVD1N4003ST	HD200010AR	R346		KRD25TJ470T	RES. CARBON 47Ω 1/4W J	nsp
D305		KVD1N4003ST	HD200010AR	R347		KRD20TJ102T	RES. CARBON 1kΩ 1/5W J	nsp
D306		KVD1N4003ST	HD200010AR	R348		KRD20TJ103T	RES. CARBON 10kΩ 1/5W J	nsp
D307		KVD1N4003ST	HD200010AR	R349		KRD25TJ103T	RES. CARBON 10kΩ 1/4W J	nsp
D308		KVD1N4003ST	HD200010AR	R350		KRD25TJ223T	RES. CARBON 22kΩ 1/4W J	nsp
D309		KVD1N4148MT	*HD201550R	R351		KRD20TJ223T	RES. CARBON 22kΩ 1/5W J	nsp
D310		KVDMTZJ6.8BT	*HD301620R	R352		KRD20TJ473T	RES. CARBON 47kΩ 1/5W J	nsp
F301H		KJCFCS5	nsp	R354		KRD25TJ102T	RES. CARBON 1kΩ 1/4W J	nsp
IC33		BVISA571D	HC10169490	VR31		BVN1PA503B01T	RES. SEMI FIXED	*RA000940R
IC34		BVINJM2068M	HC10102090	BK31		EVNDJAA03B54		
				BN31		KMD1A387	BRACKET PCB	nsp
				BN32		KWZIR3000BN31	SHIELD WIRE ASS'Y	nsp
						KJP05GB99ZM	CONNECTOR	nsp

NOTE : \*nsp\* PART IS LISTED FOR REFERENCE ONLY, MARANTZ WILL NOT SUPPLY THESE PARTS.

POS. NO	VERS. COLOR	DESCRIPTION	PART NO. (MJI)	POS. NO	VERS. COLOR	DESCRIPTION	PART NO. (MJI)
BN33		KJP05GB99ZM CONNECTOR	nsp	C425		KCFE1J124JBT CAP. FILM 0.12µF 63V J	nsp
BN38		KWB1D902120BM WIRE ASS'Y	nsp	C426		KCKT1H104ZF CAP 0.1µF 50V Z	nsp
CN30		BJPB2BXHA WAFER	nsp	C427		KCEA1EH470T CAP. ELECT 47µF 25V	OA47601020
		2.5MM PITCH JST B 2B-XH-A		C428		KCKT1H101KB CAP. CER. 100pF 50V K	nsp
CN31		KJP06GA19ZM WAFER MOLEX53014-0610	nsp	C429		KCEA1HH1R0T CAP. ELECT 1.0µF 50V	OA10505020
CN32		KJP05GA98ZM WAFER	nsp	C430		KCQI1H473JZT CAP. MYLAR 0.047µF 50V J	nsp
CN33		KJP05GA98ZM WAFER	nsp	C432		KCEA1EH470T CAP. ELECT 47µF 25V	OA47601020
CN34		KJP03GA01ZM WAFER MOLEX 5267-03A	nsp	C433		KCEA1HH2R2T CAP. ELECT 2.2µF 50V	OA22505020
CN35		KJP02GA89ZM WAFER MOLEX35328-02	nsp	C434		KCEA1HH100T CAP. ELECT 10µF 50V	OA10605020
CN36		KJP02KA060ZY WAFER 7.92MM(YUNHO)	nsp	C436		KCKT1H101KB CAP. CER. 100pF 50V K	nsp
CN37		KJP02GA01ZM WAFER MOLEX 5267-02A	nsp	C437		KCKT1H101KB CAP. CER. 100pF 50V K	nsp
CN38		KJP02GA01ZM WAFER MOLEX 5267-02A	nsp	C438		KCEA1HKS1R0T CAP. ELECT 1µF 50V	nsp
CN39		KJP02GA89ZM WAFER MOLEX35328-02	nsp	C439		KCBS1H101KBT CAP. CER. 100pF 50V K	nsp
CN71		KJP02GA19ZM WAFER	nsp	C440		KCEA1HKS1R0T CAP. ELECT 1µF 50V	nsp
CN72		KJP02GA01ZM WAFER MOLEX 5267-02A	nsp	C441		KCEA1CKS470T CAP. ELECT 47µF 16V	nsp
C304		KCEA1VH222E CAP. ELECT 2200µF 35V	EA22803510	C442		KCKT1H103ZF CAP. CER. 0.01µF 50V Z	nsp
C310		KCEA1VH222E CAP. ELECT 2200µF 35V	EA22803510	C444		KCEA1HH100T CAP. ELECT 10µF 50V	OA10605020
C313		BCKWKH103MF CAP. CER.(KH TYPE)	nsp	C445		KCEA1HH330T CAP. ELECT 33µF 50V	nsp
		DE1610-610F103M		C446		KCEA1HH100T CAP. ELECT 10µF 50V	OA10605020
C323		KCEA1EH102E CAP. ELECT 1000µF 25V	OA10802520	C447		KCKT1H103ZF CAP. CER. 0.01µF 50V Z	nsp
C343		KCEA1VH331E CAP. ELECT 330V 35V	EA33703510	C448		KCEA1HH2R2T CAP. ELECT 2.2µF 50V	OA22505020
D301		BVDPP801 DIODE PHOTO PP801 (Stanley)	*HI600010R	C449		KCEA1HH2R2T CAP. ELECT 2.2µF 50V	OA22505020
D302		BVDKBJ404G DIODE BRIDGE KBJ404G	*HE200210R	C450		KCKT1H221KB CAP. CER. 220pF 50V K	nsp
D303		KVDSR39M3V3 L.E.D SPR-39M3V3	*HI100950R	C451		KCKT1H471KB CAP. CER. 470pF 50V K	nsp
GP31		KNE75 PLATE EARTH	nsp	C452		KCBS1H103ZF CAP. CER. 0.01µF 50V Z	nsp
IC31		BVILA1235 IC FM.IF LA1235	*HC105130R	C453		KCKT1H223ZF CAP. CER. 0.022µF 50V Z	nsp
IC32		BVINJM7812FA IC REGULATOR NJM7812FA	HC3891209F	C454		KCEA1HH100T CAP. ELECT 10µF 50V	OA10605020
IC35		BVIUPC1237HA IC PROTECT UPC1237HA	*HC107040R	C458		KCKT1H102KB CAP. CER. 1000pF 50V K	nsp
IC36		KMYIR3000 HEAT SINK ASS'Y AMP IC	nsp	C459		KCQI1H102JZT CAP. MYLAR 1000pF 50V J	nsp
IC36-1		BDMKD1204PFB2-8 MOTOR FAN (BRUSHLESS)	*MM001110R	C466		KCEA1EH221T CAP. ELECT 220µF 25V	nsp
		KD1204PFB2-8		C467		KCEA1EH470T CAP. ELECT 47µF 25V	OA47601020
IC36-2		BVITDA2052 IC MONO AMP TDA2052	*HC107050R	C468		KCEA1HH100T CAP. ELECT 10µF 50V	OA10605020
JK31		KJJ5N007Z SPK TERMINAL	*YT002440R	C469		KCQI1H104JZT CAP. MYLAR 0.1µF 50V J	nsp
L303		KLEYK1R8KA COIL	*LC107200R	C470		KCQI1H104JZT CAP. MYLAR 0.1µF 50V J	nsp
RY31		BSL1B012ZE RELAY DC24V G5PA-1-8 DC24	LY10240280	C471		KCEA1HH100T CAP. ELECT 10µF 50V	OA10605020
R338		KRG1ANJ100H RES. METAL OXIDE FILM	GA05100010	D404		KVD1N4003ST DIODE 1N4003	HD200010AR
		10Ω 1W J		D405		KVD1N4003ST DIODE 1N4003	HD200010AR
T301		KLM3H001Z MPX FILTER COIL (3.8MHZ)	*LS000070R	D406		KVD1N4003ST DIODE 1N4003	HD200010AR
T302		KLR3B001Z MPX FILTER COIL(3.8MHZ)	*LS000080R	D407		KVD1N4003ST DIODE 1N4003	HD200010AR
VR32		KVV1J06B104Z VR VOL RK09K1110202	*RK000090R	D408		KVD1N4003ST DIODE 1N4003	HD200010AR
F301		KBA2C1600TLU FUSE 1.6A 250V	*FS000840R	D409		KVD1N4148MT DIODE 1N4148	*HD201550R
		<b>PCB Assy for IR3000RX (Receiver Rch)</b>		D410		KVDMTZJ6.8BT DIODE ZENER 6.8V 1/2W	*HD301620R
		KUP11448Z PCB RX RCH		F401H		KJCFCS5 HOLDER FUSE	nsp
C401		KCBS1H103ZFT CAP. CER. 0.01µF 50V Z	nsp	IC43		BVISA571D IC COMPANDOR SA571D	HC10169490
C402		KCEA1HH1R0T CAP. ELECT 1.0µF 50V	OA10505020	IC44		BVINJM2068M IC OP AMP NJM2068M	HC10102090
C403		KCKT1H103ZF CAP. CER. 0.01µF 50V Z	nsp	L401		KLQ02C270JT COIL AXAIL 27µHJ	nsp
C405		KCKT1H103ZF CAP. CER. 0.01µF 50V Z	nsp	L402		KLQ02C101JT COIL AXAIL 100µHJ	nsp
C406		KCKT1H103ZF CAP. CER. 0.01µF 50V Z	nsp	Q401		KVTKTK117YT F.E.T KTK117Y	*HF200280R
C407		KCBS1H103ZFT CAP. CER. 0.01µF 50V Z	nsp	Q402		KVTKTA1267YT T.R KTA1267Y	*HT100550R
C408		KCKT1H103ZF CAP. CER. 0.01µF 50V Z	nsp	Q403		KVTKTA1267YT T.R KTA1267Y	*HT100550R
C411		KCFE1J124JBT CAP. FILM 0.12µF 63V J	nsp	Q404		KVTKTC3199YT T.R KTC3199Y	*HT300840R
C412		KCFE1J124JBT CAP. FILM 0.12µF 63V J	nsp	Q405		KVTKTC3199YT T.R KTC3199Y	*HT300840R
C414		KCCT1H330JC CAP. CER. 33pF 50V J	nsp	Q406		KVTKTC3199YT T.R KTC3199Y	*HT300840R
C415		KCKT1H103ZF CAP. CER. 0.01µF 50V Z	nsp	Q407		KVTKTC3199YT T.R KTC3199Y	*HT300840R
C416		KCKT1H103ZF CAP. CER. 0.01µF 50V Z	nsp	Q408		KVTKTA1267YT T.R KTA1267Y	*HT100550R
C418		KCBS1H103ZFT CAP. CER. 0.01µF 50V Z	nsp	Q409		KVTKSC2316YT T.R KSC2316Y	*HT300580R
C419		KCBS1H103ZFT CAP. CER. 0.01µF 50V Z	nsp	Q410		KVTKTC3199YT T.R KTC3199Y	*HT300840R
C420		KCBS1H103ZFT CAP. CER. 0.01µF 50V Z	nsp	Q411		KVTKRC107MT T.R KRC107M	*BA001070R
C421		KCKT1H103ZF CAP. CER. 0.01µF 50V Z	nsp	Q412		KVTKRA107MT T.R KRA107M	*BA001060R
C422		KCKT1H103ZF CAP. CER. 0.01µF 50V Z	nsp	Q413		KVTKRC107MT T.R KRC107M	*BA001070R
C424		KCFE1J124JBT CAP. FILM 0.12µF 63V J	nsp	R401		KRD20TJ222T RES. CARBON 2.2kΩ 1/5W J	nsp
				R402		KRD20TJ102T RES. CARBON 1kΩ 1/5W J	nsp
				R403		KRD25TJ391T RES. CARBON 390Ω 1/4W J	nsp
				R404		KRD20TJ331T RES. CARBON 330Ω 1/5W J	nsp

NOTE : \*nsp\* PART IS LISTED FOR REFERENCE ONLY, MARANTZ WILL NOT SUPPLY THESE PARTS.

POS. NO	VERS. COLOR	DESCRIPTION	PART NO. (MJ)	POS. NO	VERS. COLOR	DESCRIPTION	PART NO. (MJ)
R405		KRD20TJ473T RES. CARBON 47kΩ 1/5W J	nsp	D401		BVDPP801 DIODE PHOTO PP801 (Stanley)	*HI600010R
R406		KRD25TJ472T RES. CARBON 4.7kΩ 1/4W J	nsp	▲ D402		BVDKBJ404G DIODE BRIDGE KBJ404G	*HE200210R
R407		KRD20TJ331T RES. CARBON 330Ω 1/5W J	nsp	D403		KVDSPR39MVW3 L.E.D SPR-39MVW3	*HI100950R
R408		KRD20TJ104T RES. CARBON 100kΩ 1/5W J	nsp				
R409		KRD20TJ102T RES. CARBON 1kΩ 1/5W J	nsp	GP41		KNE75 PLATE EARTH	nsp
R410		KRD20TJ152T RES. CARBON 1.5kΩ 1/5W J	nsp				
R411		KRD20TJ563T RES. CARBON 56kΩ 1/5W J	nsp	IC41		BVILA1235 IC FM.IF LA1235	*HC105130R
R412		KRD20TJ332T RES. CARBON 3.3kΩ 1/5W J	nsp	▲ IC42		BVINJM7812FA IC REGULATOR NJM7812FA	HC3891209F
R413		KRD20TJ102T RES. CARBON 1kΩ 1/5W J	nsp	IC45		BVIUPC1237HA IC PROTECT UPC1237HA	*HC107040R
R414		KRD20TJ103T RES. CARBON 10kΩ 1/5W J	nsp	IC46		KMYIR3000 HEAT SINK ASS'Y AMP IC	nsp
R415		KRD25TJ103T RES. CARBON 10kΩ 1/4W J	nsp	IC46-1		BDMKD1204PFB2-8 MOTOR FAN (BRUSHLESS)	*MM001110R
R416		KRD20TJ101T RES. CARBON 100Ω 1/5W J	nsp			KD1204PFB2-8	
R417		KRD20TJ221T RES. CARBON 220Ω 1/5W J	nsp	▲ IC46-2		BVITDA2052 IC MONO AMP TDA2052	*HC107050R
R418		KRD20TJ392T RES. CARBON 3.9kΩ 1/5W J	nsp	JK41		KJ5N007Z SPK TERMINAL	*YT002440R
R419		KRD20TJ223T RES. CARBON 22kΩ 1/5W J	nsp	L403		KLEYK1R8KA COIL	*LC107200R
R420		KRD20TJ222T RES. CARBON 2.2kΩ 1/5W J	nsp				
R423		KRD20TJ123T RES. CARBON 12kΩ 1/5W J	nsp	RY41		BSL1B012ZE RELAY DC24V G5PA-1-8 DC24	LY10240280
R425		KRD20TJ153T RES. CARBON 15kΩ 1/5W J	nsp	R438		KRG1ANJ100H RES. METAL OXIDE FILM	GA05100010
R426		KRD20TJ473T RES. CARBON 47kΩ 1/5W J	nsp			1W J 10 Ω	
R427		KRD20TJ103T RES. CARBON 10kΩ 1/5W J	nsp				
R429		KRD20TJ563T RES. CARBON 56kΩ 1/5W J	nsp	T401		KLM3H002Z MPX FILTER COIL (4.8MHz)	*LS000090R
R430		KRD20TJ561T RES. CARBON 560Ω 1/5W J	nsp	T402		KLR3B002Z MPX FILTER COIL(4.8MHz)	*LS000100R
R431		KRD20TJ563T RES. CARBON 56kΩ 1/5W J	nsp	VR42		KVV1J06B104Z VR VOL RK09K1110202	*RK000090R
R432		KRD20TJ333T RES. CARBON 33kΩ 1/5W J	nsp	▲ F401		KBA2C1600TLU FUSE 1.6A 250V	*FS000840R
R433		KRD20TJ682T RES. CARBON 6.8kΩ 1/5W J	nsp				
R434		KRD20TJ103T RES. CARBON 10kΩ 1/5W J	nsp				
R435		KRD20TJ103T RES. CARBON 10kΩ 1/5W J	nsp				
R437		KRD25TJ223T RES. CARBON 22kΩ 1/4W J	nsp				
R439		KRD20TJ153T RES. CARBON 15kΩ 1/5W J	nsp				
R440		KRD20TJ223T RES. CARBON 22kΩ 1/5W J	nsp	C101		KUP11434Z PCB TX	nsp
R441		KRD20TJ223T RES. CARBON 22kΩ 1/5W J	nsp	C102		KCEA1EH220T CAP. ELECT 22µF 25V	nsp
R442		KRD20TJ561T RES. CARBON 560Ω 1/5W J	nsp	C103		KCEA1EH101T CAP. ELECT 100µF 25V	nsp
R444		KRD20TJ103T RES. CARBON 10kΩ 1/5W J	nsp	C104		KCEA1EH101T CAP. ELECT 100µF 25V	nsp
R445		KRD25TJ470T RES. CARBON 47Ω 1/4W J	nsp	C105		KCEA1EH101T CAP. ELECT 100µF 25V	nsp
R446		KRD25TJ470T RES. CARBON 47Ω 1/4W J	nsp	C106		KCEA1EH101T CAP. ELECT 100µF 25V	nsp
R447		KRD20TJ102T RES. CARBON 1kΩ 1/5W J	nsp	C501		KCEA1CKS100T CAP. ELECT 10µF 16V	nsp
R448		KRD20TJ103T RES. CARBON 10kΩ 1/5W J	nsp	C502		KCEA1HKS1R0T CAP. ELECT 1µF 50V	nsp
R449		KRD25TJ103T RES. CARBON 10kΩ 1/4W J	nsp	C503		KCBS1H101KBT CAP. CER. 100pF 50V K	nsp
R450		KRD25TJ223T RES. CARBON 22kΩ 1/4W J	nsp	C504		KCBS1C222MXT CAP. CER. 2200pF 16V M	nsp
R451		KRD20TJ223T RES. CARBON 22kΩ 1/5W J	nsp	C505		KCBS1H100JCT CAP. CER. 10pF 50V J	nsp
R452		KRD20TJ473T RES. CARBON 47kΩ 1/5W J	nsp	C506		KCBS1H101KBT CAP. CER. 100pF 50V K	nsp
R454		KRD25TJ102T RES. CARBON 1kΩ 1/4W J	nsp	C507		KCEA1CKS101T CAP. ELECT 100µF 16V	nsp
VR41		BVN1PA503B01T RES. SEMI FIXED EVNDJAA03B54	*RA000940R	C508		KCEA1CKS101T CAP. ELECT 100µF 16V	nsp
				C509		KCBS1H104ZFT CAP. CER. 0.1µF 50V Z	nsp
				C510		KCBS1H101KBT CAP. CER. 100pF 50V K	nsp
				C511		KCEA1CKS100T CAP. ELECT 10µF 16V	nsp
				C512		KCCT1H100DC CAP. CER. 10pF 50V D	nsp
BK41		KMD1A387 BRACKET PCB	nsp	C513		KCEA1CKS470T CAP. ELECT 47µF 16V	nsp
BN41		KWZIR3000BN31 SHIELD WIRE ASS'Y	nsp	C514		KCBS1H103ZFT CAP. CER. 0.01µF 50V Z	nsp
BN42		KJP05GB99ZM CONNECTOR	nsp	C515		KCBS1C222MXT CAP. CER. 2200pF 16V M	nsp
BN43		KJP05GB99ZM CONNECTOR	nsp	C516		KCEA1HKS2R2T CAP. ELECT 2.2µF 50V	nsp
BN48		KWB1D902120BM WIRE ASS'Y	nsp	C517		KCEA1HKS2R2T CAP. ELECT 2.2µF 50V	nsp
				C518		KCBS1H104ZFT CAP. CER. 0.1µF 50V Z	nsp
CN40		BJPB2BXHA WAFER 2.5MM PITCH JST B 2B-XH-A	nsp	C519		KCEA1CKS101T CAP. ELECT 100µF 16V	nsp
CN41		KJP06GA19ZM WAFER MOLEX53014-0610	nsp	C520		KCEA1HKS4R7T CAP. ELECT 4.7µF 50V	nsp
CN42		KJP05GA98ZM WAFER	nsp	C521		KCEA1HKS1R0T CAP. ELECT 1µF 50V	nsp
CN43		KJP05GA98ZM WAFER	nsp	C522		KCBS1C222MXT CAP. CER. 2200pF 16V M	nsp
CN44		KJP03GA01ZM WAFER MOLEX 5267-03A	nsp	C523		KCEA1CKS470T CAP. ELECT 47µF 16V	nsp
CN45		KJP02GA89ZM WAFER MOLEX35328-02	nsp	C601		KCEA1CKS100T CAP. ELECT 10µF 16V	nsp
CN46		KJP02KA060ZY WAFER 7.92MM(YUNHO)	nsp	C602		KCEA1HKS1R0T CAP. ELECT 1µF 50V	nsp
CN47		KJP02GA01ZM WAFER MOLEX 5267-02A	nsp	C603		KCBS1H101KBT CAP. CER. 100pF 50V K	nsp
CN48		KJP02GA01ZM WAFER MOLEX 5267-02A	nsp	C604		KCBS1C222MXT CAP. CER. 2200pF 16V M	nsp
CN49		KJP02GA89ZM WAFER MOLEX35328-02	nsp	C605		KCBS1H101KBT CAP. CER. 100pF 50V K	nsp
CN81		KJP02GA19ZM WAFER	nsp	C606		KCBS1H100JCT CAP. CER. 10pF 50V J	nsp
CN82		KJP02GA01ZM WAFER MOLEX 5267-02A	nsp	C607		KCBS1H101KBT CAP. CER. 100pF 50V K	nsp
C404		KCEA1VH222E CAP. ELECT 2200µF 35V	EA22803510	C608		KCEA1CKS101T CAP. ELECT 100µF 16V	nsp
C410		KCEA1VH222E CAP. ELECT 2200µF 35V	EA22803510	C609		KCEA1CKS101T CAP. ELECT 100µF 16V	nsp
C413		BCKWKH103MF CAP. CER.(KH TYPE) DE1610-610F103M	nsp	C610		KCBS1H104ZFT CAP. CER. 0.1µF 50V Z	nsp
				C611		KCEA1CKS470T CAP. ELECT 47µF 16V	nsp
C423		KCEA1EH102E CAP. ELECT 1000µF 25V	OA10802520	C613		KCEA1CKS100T CAP. ELECT 10µF 16V	nsp
C443		KCEA1VH331E CAP. ELECT 330µF 35V	EA33703510	C614		KCCT1H100DC CAP. CER. 10pF 50V D	nsp

NOTE : \*nsp\* PART IS LISTED FOR REFERENCE ONLY, MARANTZ WILL NOT SUPPLY THESE PARTS.

POS. NO	VERS. COLOR	DESCRIPTION	PART NO. (MJI)	POS. NO	VERS. COLOR	DESCRIPTION	PART NO. (MJI)
C615		KCBS1C222MXT CAP. CER. 2200pF 16V M	nsp	R519		KRD20TJ332T RES. CARBON 3.3kΩ 1/5W J	nsp
C616		KCEA1HKS2R2T CAP. ELECT 2.2μF 50V	nsp	R520		KRD20TJ471T RES. CARBON 470Ω 1/5W J	nsp
C617		KCBS1H1042FT CAP. CER. 0.1μF 50V Z	nsp	R521		KRD20TJ104T RES. CARBON 100kΩ 1/5W J	nsp
C618		KCEA1CKS101T CAP. ELECT 100μF 16V	nsp	R522		KRD20TJ223T RES. CARBON 22kΩ 1/5W J	nsp
C619		KCEA1HKS2R2T CAP. ELECT 2.2μF 50V	nsp	R523		KRD20TJ223T RES. CARBON 22kΩ 1/5W J	nsp
C620		KCEA1HKS4R7T CAP. ELECT 4.7μF 50V	nsp	R524		KRD20TJ222T RES. CARBON 2.2kΩ 1/5W J	nsp
C621		KCEA1HKS1R0T CAP. ELECT 1μF 50V	nsp	R525		KRD20TJ152T RES. CARBON 1.5kΩ 1/5W J	nsp
C622		KCBS1C222MXT CAP. CER. 2200pF 16V M	nsp	R526		KRD20TJ272T RES. CARBON 2.7kΩ 1/5W J	nsp
D101		KVD342VCTB7T089 L.E.D RED SLR342VCTB7	HI10071210	R527		KRD20TJ100T RES. CARBON 10Ω 1/5W J	GD05100160
D501		BVDSVC203SPA DIODE VARICAP SVC203SPA	*HD400180R	R528		KRD20TJ100T RES. CARBON 10Ω 1/5W J	GD05100160
D502		BVDDNF318U IR LED DNF318U	*HI200010R	R529		KRD20TJ473T RES. CARBON 47kΩ 1/5W J	nsp
D503		BVDDNF318U IR LED DNF318U	*HI200010R	R530		KRD20TJ103T RES. CARBON 10kΩ 1/5W J	nsp
D504		BVDDNF318U IR LED DNF318U	*HI200010R	R531		K3A406 WIRE COPPER 0.58MM	nsp
D505		BVDDNF318U IR LED DNF318U	*HI200010R	R532		KRD20TJ103T RES. CARBON 10kΩ 1/5W J	nsp
D506		BVDDNF318U IR LED DNF318U	*HI200010R	R533		KRD20TJ103T RES. CARBON 10kΩ 1/5W J	nsp
D507		BVDDNF318U IR LED DNF318U	*HI200010R	R534		KRD20TJ153T RES. CARBON 15kΩ 1/5W J	nsp
D508		BVDDNF318U IR LED DNF318U	*HI200010R	R535		KRD20TJ682T RES. CARBON 6.8kΩ 1/5W J	nsp
D509		BVDDNF318U IR LED DNF318U	*HI200010R	R601		KRD20TJ222T RES. CARBON 2.2kΩ 1/5W J	nsp
D510		BVDDNF318U IR LED DNF318U	*HI200010R	R602		KRD20TJ222T RES. CARBON 2.2kΩ 1/5W J	nsp
D511		BVDDNF318U IR LED DNF318U	*HI200010R	R603		KRD20TJ103T RES. CARBON 10kΩ 1/5W J	nsp
D512		BVDDNF318U IR LED DNF318U	*HI200010R	R604		KRD20TJ153T RES. CARBON 15kΩ 1/5W J	nsp
D513		BVDDNF318U IR LED DNF318U	*HI200010R	R605		KRD20TJ103T RES. CARBON 10kΩ 1/5W J	nsp
D601		BVDSVC203SPA DIODE VARICAP SVC203SPA	*HD400180R	R606		KRD20TJ332T RES. CARBON 3.3kΩ 1/5W J	nsp
D602		BVDDNF318U IR LED DNF318U	*HI200010R	R607		KRD20TJ102T RES. CARBON 1kΩ 1/5W J	nsp
D603		BVDDNF318U IR LED DNF318U	*HI200010R	R608		KRD20TJ122T RES. CARBON 1.2kΩ 1/5W J	nsp
D604		BVDDNF318U IR LED DNF318U	*HI200010R	R609		KRD20TJ332T RES. CARBON 3.3kΩ 1/5W J	nsp
D605		BVDDNF318U IR LED DNF318U	*HI200010R	R610		KRD20TJ332T RES. CARBON 3.3kΩ 1/5W J	nsp
D606		BVDDNF318U IR LED DNF318U	*HI200010R	R611		KRD20TJ104T RES. CARBON 100kΩ 1/5W J	nsp
D607		BVDDNF318U IR LED DNF318U	*HI200010R	R612		KRD20TJ561T RES. CARBON 560Ω 1/5W J	nsp
D608		BVDDNF318U IR LED DNF318U	*HI200010R	R613		KRD20TJ221T RES. CARBON 220Ω 1/5W J	nsp
D609		BVDDNF318U IR LED DNF318U	*HI200010R	R614		KRD20TJ104T RES. CARBON 100kΩ 1/5W J	nsp
D610		BVDDNF318U IR LED DNF318U	*HI200010R	R615		KRD20TJ682T RES. CARBON 6.8kΩ 1/5W J	nsp
D611		BVDDNF318U IR LED DNF318U	*HI200010R	R616		KRD20TJ104T RES. CARBON 100kΩ 1/5W J	nsp
D612		BVDDNF318U IR LED DNF318U	*HI200010R	R617		KRD20TJ102T RES. CARBON 1kΩ 1/5W J	nsp
D613		BVDDNF318U IR LED DNF318U	*HI200010R	R618		KRD20TJ223T RES. CARBON 22kΩ 1/5W J	nsp
IC51		BVINJM2068M IC OP AMP NJM2068M	HC10102090	R619		KRD20TJ332T RES. CARBON 3.3kΩ 1/5W J	nsp
IC52		BVISA571D IC COMPANDOR SA571D	HC10169490	R620		KRD20TJ471T RES. CARBON 470Ω 1/5W J	nsp
IC61		BVINJM2068M IC OP AMP NJM2068M	HC10102090	R621		KRD20TJ104T RES. CARBON 100kΩ 1/5W J	nsp
L501		KLQ02C101JT COIL AXAIL 100UHJ	nsp	R622		KRD20TJ223T RES. CARBON 22kΩ 1/5W J	nsp
L601		KLQ02C101JT COIL AXAIL 100UHJ	nsp	R623		KRD20TJ223T RES. CARBON 22kΩ 1/5W J	nsp
Q501		KVTKTC3194YT TR KTC3194Y	*HT300850R	R624		KRD20TJ222T RES. CARBON 2.2kΩ 1/5W J	nsp
Q502		KVTKTC3194YT TR KTC3194Y	*HT300850R	R625		KRD20TJ152T RES. CARBON 1.5kΩ 1/5W J	nsp
Q503		KVTKTA1267YT T.R KTA1267Y	*HT100550R	R626		KRD20TJ272T RES. CARBON 2.7kΩ 1/5W J	nsp
Q601		KVTKTC3194YT TR KTC3194Y	*HT300850R	R627		KRD20TJ272T RES. CARBON 2.7kΩ 1/5W J	nsp
Q602		KVTKTC3194YT TR KTC3194Y	*HT300850R	R628		KRD20TJ100T RES. CARBON 10Ω 1/5W J	GD05100160
Q605		KVTKTA1267YT T.R KTA1267Y	*HT100550R	R629		KRD20TJ100T RES. CARBON 10Ω 1/5W J	GD05100160
R101		KRD25TJ122T RES. CARBON 1.2kΩ 1/4W J	nsp	R630		KRD20TJ473T RES. CARBON 47kΩ 1/5W J	nsp
R501		KRD20TJ222T RES. CARBON 2.2kΩ 1/5W J	nsp	R631		KRD20TJ103T RES. CARBON 10kΩ 1/5W J	nsp
R502		KRD20TJ103T RES. CARBON 10kΩ 1/5W J	nsp	R632		K3A406 WIRE COPPER 0.58MM	nsp
R503		KRD20TJ332T RES. CARBON 3.3kΩ 1/5W J	nsp	R633		KRD20TJ103T RES. CARBON 10kΩ 1/5W J	nsp
R504		KRD20TJ103T RES. CARBON 10kΩ 1/5W J	nsp	R634		KRD20TJ223T RES. CARBON 22kΩ 1/5W J	nsp
R505		KRD20TJ222T RES. CARBON 2.2kΩ 1/5W J	nsp	BN12		KWB2B902070EN WIRE ASS'Y	nsp
R506		KRD20TJ102T RES. CARBON 1kΩ 1/5W J	nsp	BN51		KJP03HA37ZM WAFER	nsp
R507		KRD20TJ153T RES. CARBON 15kΩ 1/5W J	nsp	BN61		KJP03HA37ZM WAFER	nsp
R508		KRD20TJ332T RES. CARBON 3.3kΩ 1/5W J	nsp	CN11		KJP04GB03ZM WAFER 5268-04A (4P)	YJ07002460
R509		KRD20TJ332T RES. CARBON 3.3kΩ 1/5W J	nsp	CN12		KJP02GA19ZM WAFER	nsp
R510		KRD20TJ104T RES. CARBON 100kΩ 1/5W J	nsp	CN51		KJP03TT45ZO WAFER	nsp
R511		KRD20TJ221T RES. CARBON 220Ω 1/5W J	nsp	CN61		KJP03TT45ZO WAFER	nsp
R512		KRD20TJ104T RES. CARBON 100kΩ 1/5W J	nsp	▲ IC11		BVINJM7812FA IC REGULATOR NJM7812FA	HC3891209F
R513		KRD20TJ122T RES. CARBON 1.2kΩ 1/5W J	nsp	▲ JK11		BJJ2D007Z JACK PHONE TC38-160-01G	*YJ002370R
R514		KRD20TJ561T RES. CARBON 560Ω 1/5W J	nsp	▲ JK12		BJJ1B001Z JACK DC IN TC18-013-04	*YJ002380R
R515		KRD20TJ101T RES. CARBON 100Ω 1/5W J	nsp	Q504		BVT2SC2911S T.R 2SC2911S	HT329111B0
R516		KRD20TJ104T RES. CARBON 100kΩ 1/5W J	nsp	Q505		BVT2SC2911S T.R 2SC2911S	HT329111B0
R517		KRD20TJ102T RES. CARBON 1kΩ 1/5W J	nsp	Q603		BVT2SC2911S T.R 2SC2911S	HT329111B0
R518		KRD20TJ223T RES. CARBON 22kΩ 1/5W J	nsp	Q604		BVT2SC2911S T.R 2SC2911S	HT329111B0

NOTE : "nsp" PART IS LISTED FOR REFERENCE ONLY, MARANTZ WILL NOT SUPPLY THESE PARTS.



POS. NO	VERS. COLOR	DESCRIPTION	PART NO. (MJI)
SW11		BSS2D005Z SW SLIDE SKL-42D01N-G6	*SS000690R
TH51		KRTNTC5D132KPC THERMISTOR(1.3K) NTC5D132KPC(TA)	*HH000100R
TH61		KRTNTC5D132KPC THERMISTOR(1.3K) NTC5D132KPC(TA)	*HH000100R
T501		KLI9A001Z I.F.T (3.8MHz)	*TC000400R
T601		KLI9A003Z I.F.T (4.8MHz)	*TC000410R

NOTE : \*nsp\* PART IS LISTED FOR REFERENCE ONLY, MARANTZ WILL NOT SUPPLY THESE PARTS.