

# Service Manual

MA500U/K/F  
Mono Amplifier

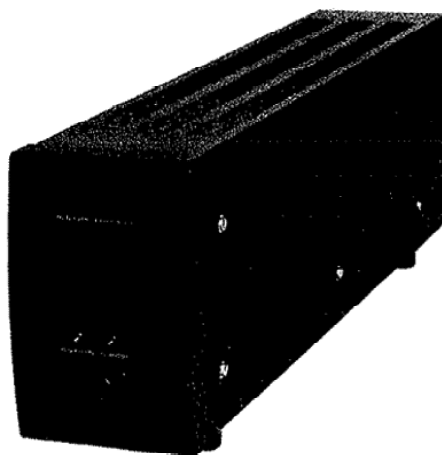

## TABLE OF CONTENTS

SECTION	PAGE
1. TECHNICAL SPECIFICATIONS .....	1
2. TEST EQUIPMENT REQUIRED FOR SERVICING .....	1
3. IDLING CURRENT ADJUSTMENT .....	1
4. BLOCK DIAGRAM .....	2
5. SCHEMATIC DIAGRAM .....	3
6. CIRCUIT BOARD DIAGRAM .....	5
7. EXPLODED VIEW AND PARTS LIST .....	7
8. ELECTRICAL PARTS LIST .....	9

---

# marantz®

---

## model MA500

First issue : 1993

## MARANTZ DESIGN AND SERVICE

Using superior design and selected high grade components, MARANTZ company has created the ultimate in stereo sound.

Only original MARANTZ parts can insure that your MARANTZ product will continue to perform to the specifications for which it is famous.

Parts for your MARANTZ equipment are generally available to our National Marantz Subsidiary or Agent.

### ORDERING PARTS:

Parts can be ordered either by mail or by telex. In both cases, correct part number has to be specified. The following information must be supplied to eliminate delays in processing your order:

1. Complete address
2. Complete part numbers and quantities required
3. Description of parts
4. Model number for which part is required
5. Way of shipment
6. Signature: any order form or telex must be signed otherwise such part order will be considered as null and void.

### MARANTZ EUROPE B.V.

Vestdijk 9  
5600 MD Eindhoven  
The Netherlands  
Phone : +31-40-758290  
Fax : +31-40-758299  
Telex : 35000 PHTC NL routing ind.

### MARANTZ USA

1150 FEEHANVILLE DR.  
MOUNT PROSPECT, ILLNOIS 60056  
U.S.A.  
PHONE: 800-654-6633  
FAX: 708-299-4005

## 日本マランツ株式会社

本社 〒228 神奈川県相模原市相模大野7丁目35番1号  
営業本部 〒150 東京都渋谷区恵比寿南1丁目11番9号

### SHOCK, FIRE HAZARD SERVICE TEST:

**CAUTION:** After servicing this appliance and prior to returning to customer, measure the resistance between either primary AC cord connector pins (with unit NOT connected to AC mains and its Power switch ON), and the face or Front Panel of product and controls and chassis bottom.

Any resistance measurement less than 1 Megohms should cause unit to be repaired or corrected before AC power is applied, and verified before return to user/customer. Ref. UL Standard NO. 1270, Para 74. 3. D (Mandatory Test after servicing Electrical Appliances, effective 7-1-83).

In case of difficulties, do not hesitate to contact the Technical Department at abovementioned address.

## 1. TECHNICAL SPECIFICATIONS

Rated Power Output	125 Watts into 8 Ω RMS
Total Harmonic Distortion	<0.05% at 8 Ω
Input Sensitivity/Input Impedance	1 V RMS/30 kΩ
Frequency Response	10 Hz to 100 kHz (-1 dB at 1 Watts)
Signal to Noise Ratio (A-weighted)	>116 dB
Damping Factor (at 8 Ω)	200
Power Requirement	(U) : 120 V AC, 60 Hz (K) : 110/120/220/240 V AC 50/60 kHz
Power Consumption	(U) : (full rated output into 8 Ω) 230 Watts (K) : (10 % THD output into 8 Ω) 300 Watts
Dimensions	
Width	3 - 5/16 inches (84 mm)
Height	5 - 3/16 inches (132 mm)
Depth	17 - 3/4 inches (450 mm)
Weight	13.2 lbs (6.0 kg)
Accessories	Remote control cable X1

Design and specifications subject to change without notice.

## 規格

定格出力	130 W 8 Ω RMS
歪率	0.05 %
定格入力レベル	1 V RMS
周波数特性(-1 dB)	10~100 kHz
SN比(IHF-A)	95 dB
ダンピングファクタ(1 kHz)	170
電源	AC100 V, 50/60 Hz
消費電力(電気用品取締法)	96 W
外形寸法	
幅	84 mm
高さ	132 mm
奥行き	450 mm
重量	6 kg
付属品	リモコン用ケーブルX1

本機の規格および外観は改良のため予告なく変更することがありますが、ご了承ください。

## 2. TEST EQUIPMENT REQUIRED FOR SERVICING

This table the test equipment required for servicing.

Item	Use
Distortion Analyzer	Distortion measurements
Audio Oscillator	Sinewave and squarewave signal source
ACVTVM	Voltage measurements (AC)
Oscilloscope	Waveform analysis and trouble shooting and ASO alignment
Circuit Tester	Trouble shooting
DCVTVM	Voltage measurements (DC)
AC Wattmeter	Monitors primary power to amplifier
Line Voltmeter	Monitors potential of primary power to amplifier
Variable Autotransformer	Adjust level of primary power to amplifier
Shorting Plug	Shorts amplifier input to eliminate noise pickup

## 3. IDLING CURRENT ADJUSTMENT

- 1) With the power OFF, set semi-fixed resistor R708 on the PC board (P701) to the center position.
- 2) Connect a digital multimeter, set for the DC V range, between the test pins (J702) on the PC board (P701).
- 3) After the above, adjust the idling current as follows :  
Turn the power ON and adjust semi-fixed resistor R708 while observing the digital multimeter indication.  
\* The target value is 7 mV (19 mA).

### [Reference]

When a set whose idling current has been adjusted is switched on with after 1 minute it reaches about 4.5 mV. After 10 minutes, it reaches a balanced state and stabilizes at 7 mV (target). Therefore, if the adjustment is made between 30 seconds and 1 minute after the power is switched on, adjust to 3.5 mV. In the same way, if 1 to 2 minutes have passed since the power was switched on, adjust to 4.5 mV. From 2 to 3 minutes, adjust to 6 mV. After more than 5 minutes since the power was switched on, adjust to the setting of 7 mV.

Here is a reference table for the adjustment values.

Time since power switched on	Idling current adjustment
30 seconds - 1 minute	3.5 mV
1 - 2 minutes	4.5 mV
2 - 3 minutes	6 mV
More than 5 minutes	7 mV

## アイドリング電流の調整

- 1) 電源を投入しない状態で、プリント基板(P701)内の半固定抵抗、R708を中央の位置とします。
- 2) プリント基板(P701)内のテストピン(J702)の両端に、直流電圧レンジとしたデジタルボルトメーターを接続します。
- 3) 上記の設定が完了した後、アイドリング電流の調整を次の様に行ないます。  
電源を投入しプリント基板(P701)内の半固定抵抗R708を、デジタルボルトメーターの指示により調整します。  
\* 設定値は、7 mV(19 mA)です。

### 【参考】

アイドリング電流調整済みのSETを、冷えた状態から電源投入すると、30秒後に約3.5 mV、1分後に約4.5 mVに達します。10分後には平衡状態となり、7 mV(設定値)に安定します。従って、電源投入後、30秒から1分にわたって調整作業を行う場合は、3.5 mVに調整します。同様に、1分後から2分後にわたる場合は、4.5 mVに調整し、2分後から3分後にわたる場合は、6 mVに調整します。5分後以降は、設定値である7 mVに調整します。  
下記に示す表を参照下さい。

電源投入後経過時間	アイドリング電流調整値
30秒後~1分後	3.5 mV
1分後~2分後	4.5 mV
2分後~3分後	6 mV
5分後~	7 mV

## 4. BLOCK DIAGRAM

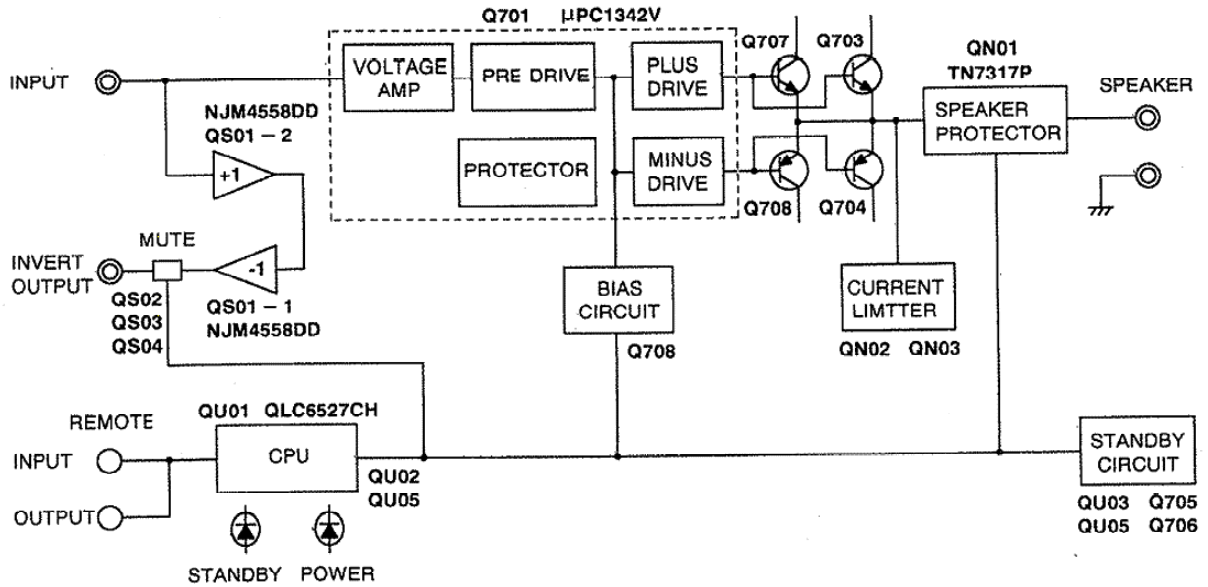

### ● PIN ASSIGNMENT TABLE

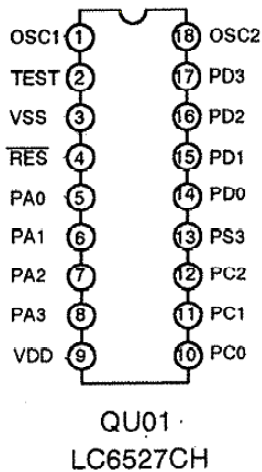

PIN NO.	PORT NAME	I/O	ACT	FUNCTION
1	OSC1	I	-	4.00MHz
2	TEST	-	-	GND
3	VSS	-	-	GND
4	RES	I	L	REST
5	PA0	-	-	GND
6	PA1	-	-	GND
7	PA2	-	-	GND
8	PA3	-	-	GND
9	VDD	-	-	+5V
10	PC0	I	L	RC-5 INPUT
11	PC1	O	L	POWER ON LED
12	PC2	O	L	STAND BY LED
13	PC3	O	-	RC-5 RECEIVE LED
14	PD0	O	H	STAND BY OUT
15	PD1	I	-	5V
16	PD2	I	-	GND
17	PD3	I	-	GND(*SYSTEM1)/+5V(**SYSTEM2)
18	OSC2	I	-	4.00MHz

NOTE 1) \*SYSTEM1 is for the Remote Controller with Power SW (ex. Moedl AV500, etc.).

2) \*\*SYSTEM2 is for the Remote Controller that turns on the Power SW by Function SW (ex. Model SR-92, etc.).

◆BUS SYSTEM (SYSTEM1/SYSTEM2) SW is on the Rea panel.

NOTE 1) \*: SYSTEM1 はPOWER SWを有するリモコン (例. Model AV500用等) に対応。

2) \*\*: SYSTEM2はFUNCTION SWでPower onするリモコン (例. PM700AV用等) に対応。

◆BUS SYSTEM (SYSTEM1/SYSTEM2) SWは、リアパネルにあります。

# 5. SCHEMATIC DIAGRAM

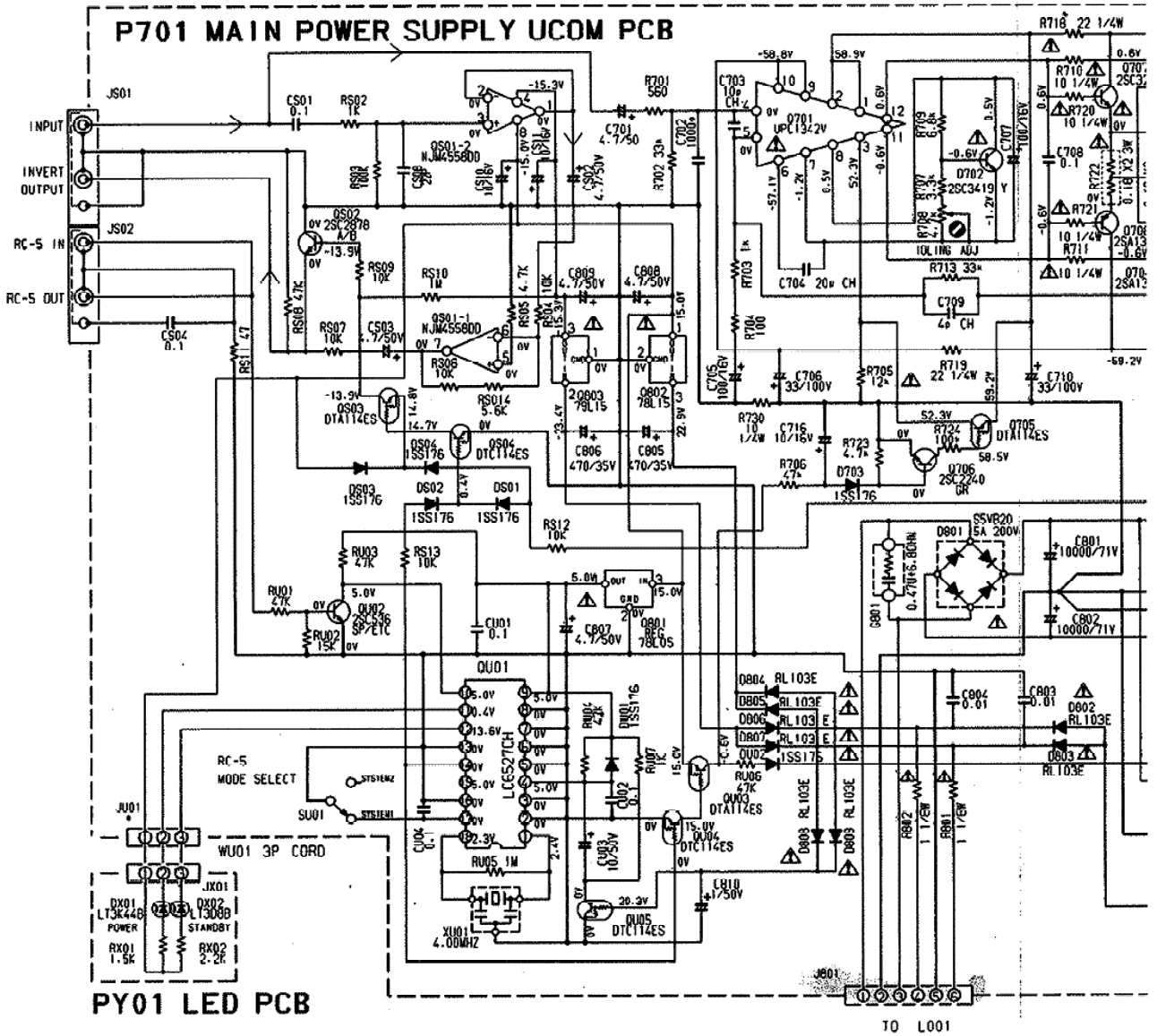

PY01 LED PCB

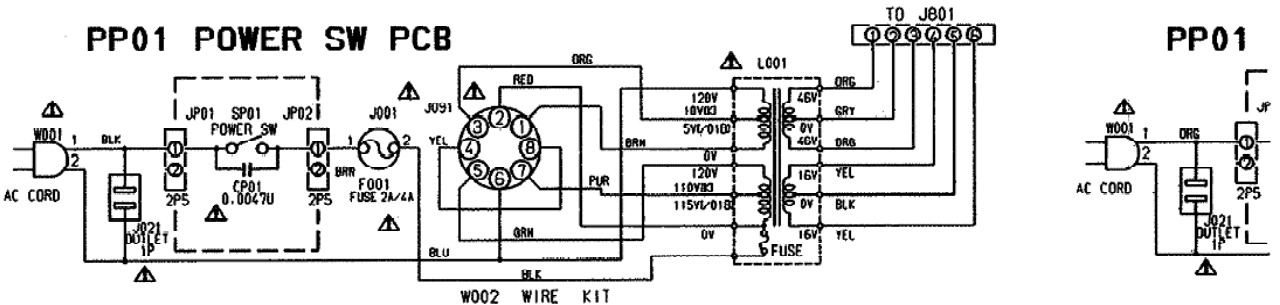

PP01

FOR K/01B

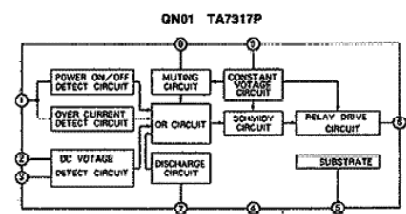
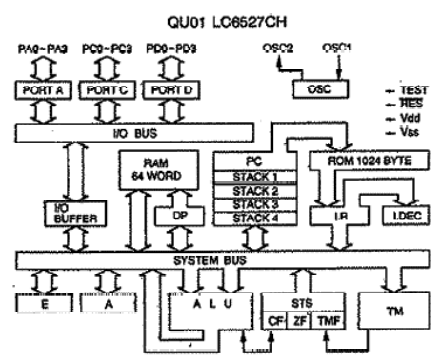
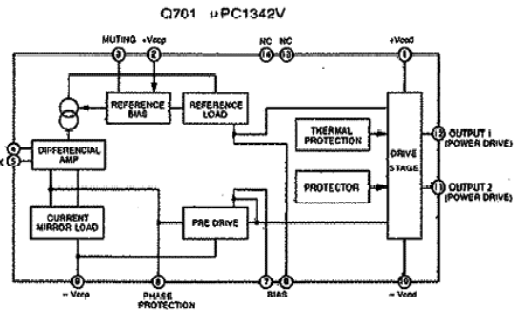
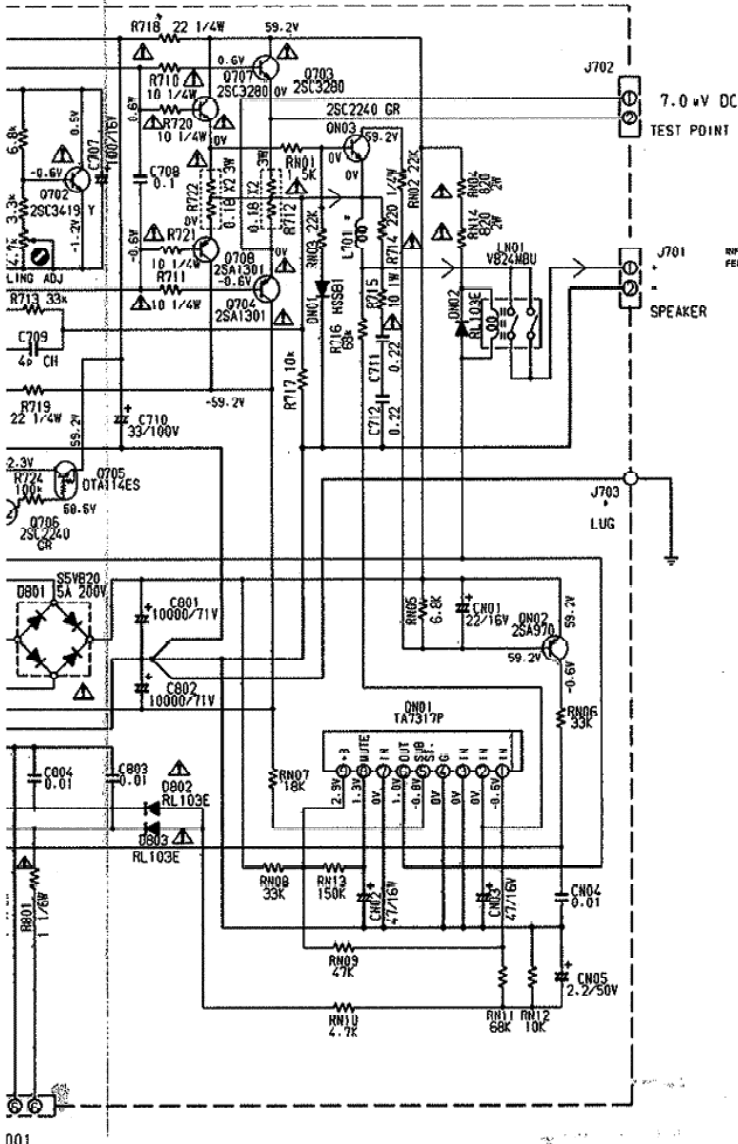

**PP01 POWER SW PCB**

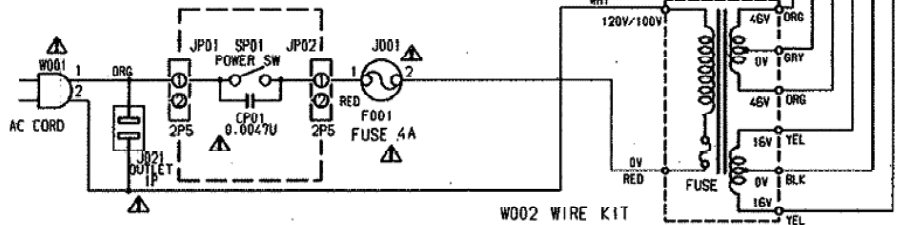

FOR U/F

# 6. CIRCUIT BOARD DIAGRAM (PATTERN SIDE)

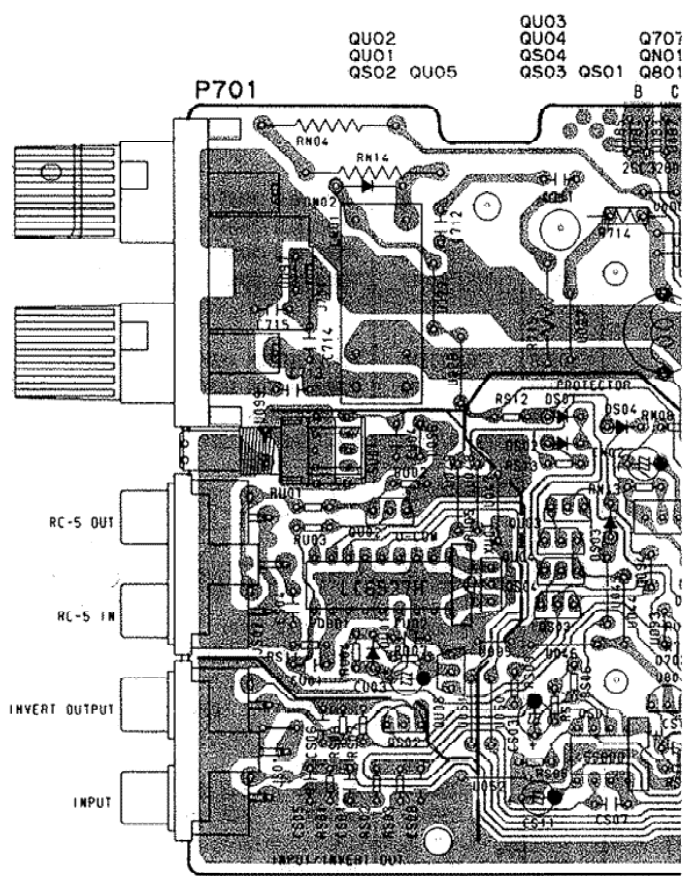
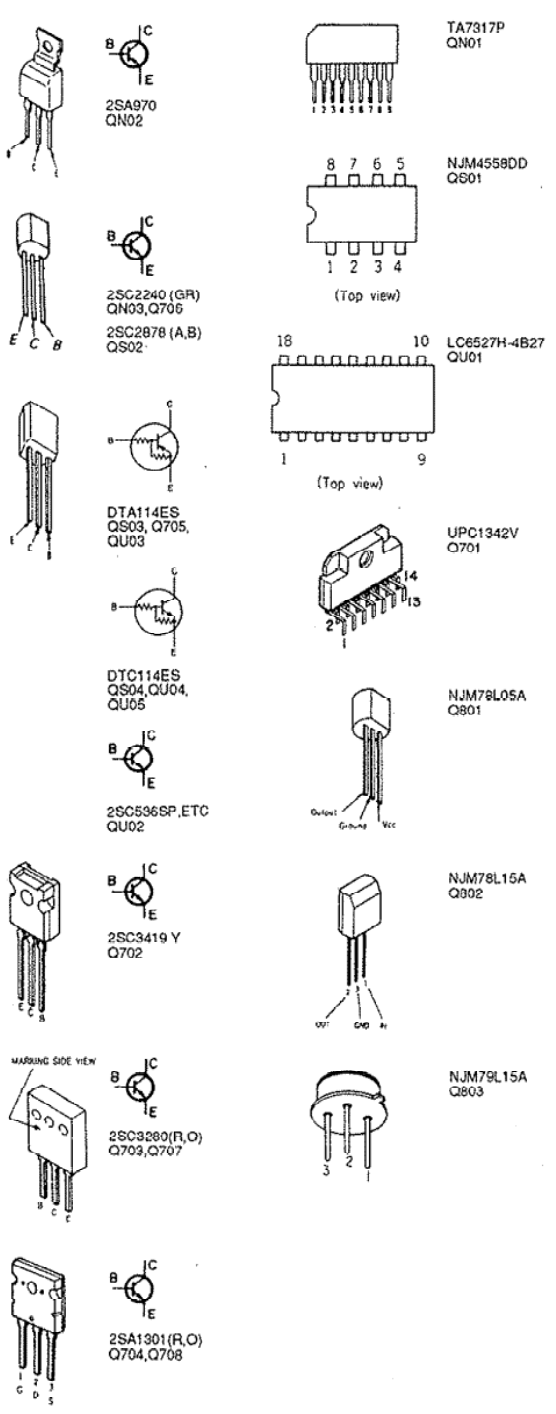

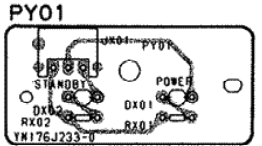
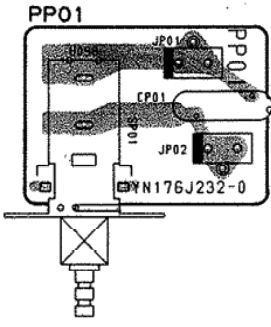
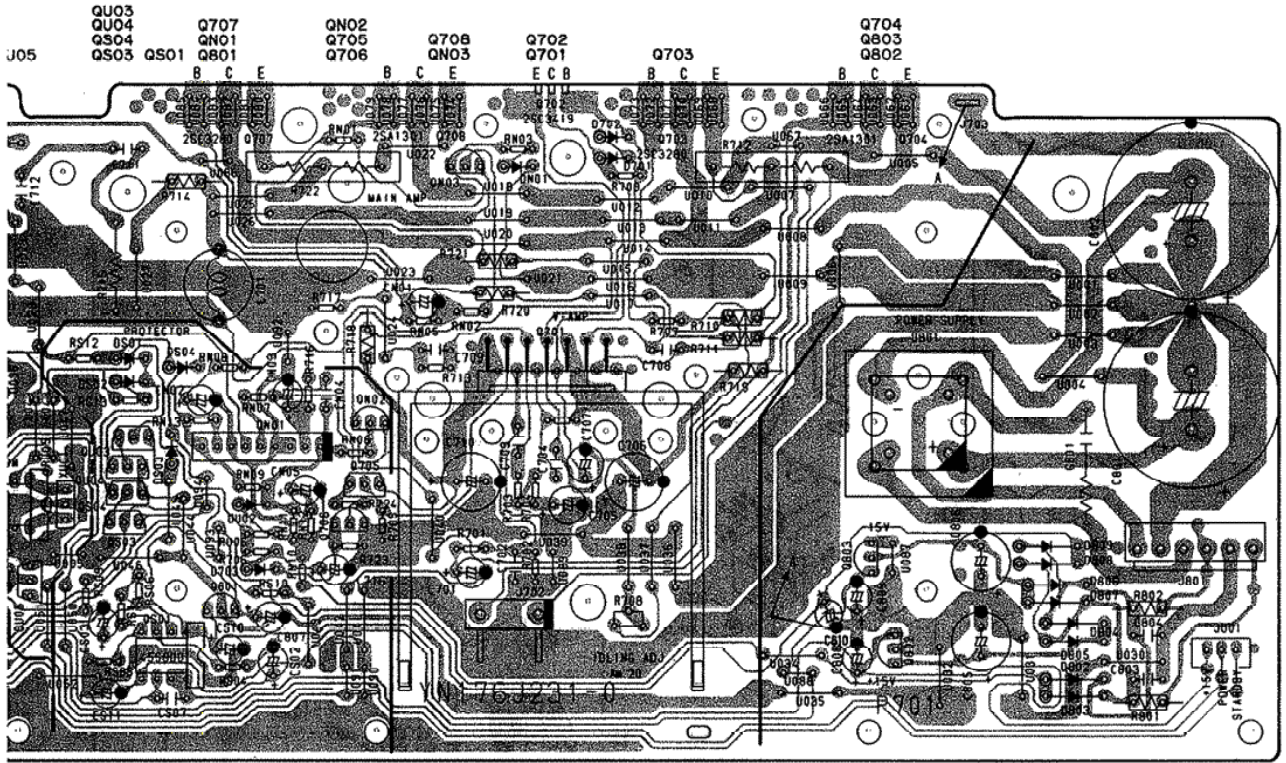





REF. DESIG.	PART NO.	DESCRIPTION
001B	176J248110	FRONT PANEL AL PANEL (F) GOLD
001B	176J248010	FRONT PANEL AL PANEL (K) BLACK
001B	176J248110	FRONT PANEL AL PANEL (K) GOLD
001B	176J248010	FRONT PANEL AL PANEL (U) BLACK
004B	176J355010	LENS FOR POWER/STADBY
005B	176J105110	FRONT MLD CHASSIS (F) GOLD
005B	176J105010	FRONT MLD CHASSIS (K) BLACK
005B	176J105110	FRONT MLD CHASSIS (K) GOLD
005B	176J105010	FRONT MLD CHASSIS (U) BLACK
008B	176J270510	POWER BUTTON ASSY (F) GOLD
008B	176J270500	POWER BUTTON ASSY (K) BLACK
008B	176J270510	POWER BUTTON ASSY (K) GOLD
008B	176J270500	POWER BUTTON ASSY (U) BLACK
001D	176J257110	LID (F) GOLD
001D	176J257010	LID (K) BLACK
001D	176J257110	LID (K) GOLD
001D	176J257010	LID (U) BLACK ←
007D	51260306M0	B. T. SCREW (W/W) 3 X 6(M)
010D	176J265020	INDICATOR (F) GOLD
001F	173H120010	INSULATOR DENKA SHEET
007G	176J057010	LEG
012G	176J259010	BUSHING FOR SHARP EDGE
014G	176J056010	BUFFER FOR POWER TRANS. SIDE
901G	176J250020	REAR PANEL (F) GOLD
901G	176J194090	REAR PANEL U BLACK
918G	51260408M0	B. T. SCREW (W/W) 4 X 8(M)
905G	1455259210	BUSHING AC CORD BUSH (F) GOLD
905G	1455259210	BUSHING AC CORD BUSH (K) BLACK
905G	1455259210	BUSHING AC CORD BUSH (K) GOLD
905G	450H259010	BUSHING AC CORD BUSH (U) BLACK
002L	51260315M0	B. T. SCREW (W/W) 3 X 15(M)
005L	51260310M0	B. T. SCREW (W/W) 3 X 10(M)
<b>PACKING</b>		
001S	176J801110	PACKING CASE (F)
005S	176J809010	CUSHION (F)
006S	176J809020	CUSHION (F)
001T	176J851110	USER MANUAL (F)
001T	176J851350	USER MANUAL (K)
001T	176J851250	USER MANUAL (U)
004T	963100150	WARRANTY CARD (F)
007T	9012540010	POLYETHY BAG (F)

(F):JAPAN, (K):FAR EAST, (U):U.S.A.

REF. DESIG.	PART NO.	DESCRIPTION
▲ F001	FS10400300	FUSE T4A 125V UL/CSA (F)
▲ F001	FS10200850	FUSE 2 A 250V BS LISTED (K)
▲ F001	FS10400300	FUSE T4A 125V UL/CSA (U)
▲ J001	YJ08000290	JACK FUSE HOLDER
▲ J021	YJ04001990	JACK AC OUTLET 1P M7030
▲ J091	BY05080070	VOLT. SELECT. 2POLE-4POSITION (K)
▲ L001	TS18629030	POWER TRANSFORMER (F)
▲ L001	TS18629040	POWER TRANSFORMER (K)
▲ L001	TS18629020	POWER TRANSFORMER (U)
▲ W001	YC01800450	A. C. POWER CORD 12A 300V (F)
▲ W001	YC01800330	A. C. POWER CORD UL1CSA LISTED (U)
▲ Z001	FS10400850	FUSE 4 A 250V UL/CSA (K)
▲ Z002	YJ04001240	AC ADAPTER, SMK S-16116 (K)
Z003	ZD00900100	CONNECTIVE CORD RCA PIN CORD

**NOTE ON SAFETY:**

Symbol ▲ Fire or electrical shock hazard. Only original parts should be used to replaced any part marked with symbol ▲. Any other component substitution ( other than original type), may increase risk of fire or electrical shock hazard.

安全上の注意:

▲ が付いている部品は、安全上重要な部品です。必ず指定されている部品番号の部品を使用してください。

# 8. ELECTRICAL PARTS LIST

## ASSIGNMENT OF COMMON PARTS CODES.

### RESISTOR

R\*\*\*: (1) GD05 xxx 140, Carbon film fixed resistor, ±5% 1/4W  
 R\*\*\*: (2) GD05 xxx 160, Carbon film fixed resistor, ±5% 1/6W

① — Resistance value

Examples:

① Resistance value

0.1 Ω...001	10 Ω...100	1k Ω...102	100k Ω...104
0.5 Ω...005	18 Ω...180	2.7k Ω...272	680k Ω...684
1 Ω...010	100 Ω...101	10k Ω...103	1M Ω...105
6.8 Ω...068	390 Ω...391	22k Ω...223	4.7M Ω...475

(Note) Please distinguish 1/4W from 1/6W by the shape of parts used actually.

C\*\*\*: CERAMIC CAP.

(1) DD1x xxx 370, Ceramic condenser

Disc type  
Temp.coeff.P350~N1000.50V

① ②  
Capacity value  
Tolerance

Examples

① Tolerance (Capacity deviation)

±0.25pF...0  
±0.5pF...1  
±5%...5

\* Tolerance of COMMON PARTS handled here are as follows:

0.5pF~5pF...±0.25pF  
6pF~10pF...±0.5pF  
12pF~560pF...±5%

② Capacity value

0.5pF...005	3pF...030	100pF...101
1pF...010	10pF...100	220pF...221
1.5pF...015	47pF...470	560pF...561

C\*\*\*: CRAMIC CAP.

(1) DK16 xxx 300, High dielectric constant ceramic condenser

Disc type  
Temp.chara. 2B4, 50V

①  
Capacity value

Examples

② Capacity value

100pF...101	1000pF...102	10000pF...103
470pF...471	2200pF...222	

C\*\*\*: ELECTROLY CAP. (  $\text{⏏}$  ), FILM CAP. (  $\text{⏏}$  )

(1) EA xxx xxx 10, Electrolytic condenser

One-way lead type, Tolerance ±20%

① ②  
Dielectric strength  
Capacity value

Examples

① Capacity value

01 μF...104	4.7 μF...475	100 μF...107
0.33 μF...334	10 μF...106	330 μF...337
1 μF...105	22 μF...226	1100 μF...108
		2200 μF...228

② Working voltage

6.3V...006	25V...025
10V...010	35V...035
16V...016	50V...050

(2) DF15 xxx 350, Plastic film condenser

One-way type, Mylar ±5% 50V

①  
Capacity value

Examples

① Capacity value

0.001 μF (1000pF)...102	0.1 μF...104
0.0018 μF...182	0.56 μF...564
0.01 μF...103	1 μF...105
0.015 μF...153	

REF. DESIG.	PART NO.	DESCRIPTION
▲ PP01	YN176J2320	<b>PP01-POWER SW CIRCUIT BOARD</b> POWER SW PCB
CP01	DK17472840	CERAMIC 0.0047UF ±20% AC400V
SP01	SP01011540	PUSH SWITCH ESB-82106V <i>Use QP 27612924</i> <b>PY01-LED CIRCUIT BOARD</b>
▲ PY01	YN176J2330	LED PCB
DX01	H110095320	L. E. D. LT3K44B GREEN
DX02	H110062320	L. E. D. LT308B RED
▲ P701	YN176J2310	<b>P701-MAIN POWER SUPPLY CIRCUIT BOARD</b> MAIN POWER SUPPLY U-CON PCB
		<b>P701-CAPACITORS</b>
CN04	DK18103310	CERAMIC 0.01 μF +80% -20% 50V
CS01	DD38104010	CERAMIC 0.1 μF +80% -20% 50V
CS04	DD38104010	CERAMIC 0.1 μF +80% -20% 50V
CS08	DD15220300	CERAMIC 22pF ±5% 50V
CU01	DD38104010	CERAMIC 0.1 μF +80% -20% 50V
CU02	DD38104010	CERAMIC 0.1 μF +80% -20% 50V
CU04	DD38104010	CERAMIC 0.1 μF +80% -20% 50V
C703	DD11100300	CERAMIC 10pF ±0.5pF 50V
C704	DD15200300	CERAMIC 20pF ±5% 50V
C706	EA33610010	ELECT 33 μF 100V
C709	DD10040300	CERAMIC 4pF ±0.25pF 50V
C710	EA33610010	ELECT 33 μF 100V
▲ C801	EB10907160	ELECT 10000 μF 71V
▲ C802	EB10907160	ELECT 10000 μF 71V
C803	DK18103310	CERAMIC 0.01 μF +80% -20% 50V
C804	DK18103310	CERAMIC 0.01 μF +80% -20% 50V
C805	EA4770351R	ELECT 470 μF 35V
C806	EA4770351R	ELECT 470 μF 35V
		<b>P701-RESISTORS</b>
▲ RN04	GA05821020	820 Ω 2W
▲ RN14	GA05821020	820 Ω 2W
R708	RA04720760	TRIMMING 4.7K Ω
▲ R710	GG05100140	10 Ω ±5% 1/4W
▲ R711	GG05100140	10 Ω ±5% 1/4W
▲ R712	BW10000110	0.18 Ω 3W X 2
R714	GG05221140	220 Ω ±5% 1/4W
▲ R715	GA05100010	10 Ω 1W

REF. DESIG.	PART NO.	DESCRIPTION		
<b>P701-RESISTORS</b>				
▲ R718	NF02220140	22Ω	± 2%	1/4W (FUSIBLE)
▲ R719	NF02220140	22Ω	± 2%	1/4W (FUSIBLE)
▲ R720	GG05100140	10Ω	± 5%	1/4W
▲ R721	GG05100140	10Ω	± 5%	1/4W
▲ R722	BW10000110	0.18Ω		3W X2
▲ R801	GG05010160	1Ω	± 5%	1/6W
▲ R802	GG05010160	1Ω	± 5%	1/6W
U003	GG05100140	10Ω	± 5%	1/4W
<b>P701-SEMICONDUCTORS</b>				
▲ DN01	HD20027010	DIODE	HSS81	
DN02	HD20003000	DIODE	RL103E (RECTRON)/DSF10C	
DS01	HD20002000	DIODE	1SS176. MA165. 1SS254	
DS04	HD20002000			
DU01	HD20002000	DIODE	1SS176. MA165. 1SS254	
DU02	HD20002000	DIODE	1SS176. MA165. 1SS254	
D703	HD20002000	DIODE	1SS176. MA165. 1SS254	
▲ D801	HE20009290	DIODE	S5VB20	
D802	HD20003000	DIODE	RL103E (RECTRON)/DSF10C	
D809	HD20003000			
QN01	HC10042050	IC	TA7317P	
QN02	HT109701A0	TRANSISTOR	2SA970	
▲ QN03	HT322401A0	TRANSISTOR	2SC2240 GR	
QS01	HC10008090	IC	NJM4558DD	
QS02	HT328782A0	TRANSISTOR	2SC2878 (A, B)	
QS03	BA10007210	TRANSISTOR	DIGITAL DTA114ES	
QS04	BA20010210	TRANSISTOR	DIGITAL DTC114ES	
QU01	HU10042030	MICROPROCESSOR	LC6527H-4B27	
QU02	HT30001000	TRANSISTOR	2SC536SP. ETC	
QU03	BA10007210	TRANSISTOR	DIGITAL DTA114ES	
QU04	BA20010210	TRANSISTOR	DIGITAL DTC114ES	
QU05	BA20010210	TRANSISTOR	DIGITAL DTC114ES	

REF. DESIG.	PART NO.	DESCRIPTION	
▲ Q701	HC10242060	IC	UPC1342V
▲ Q702	HT334191Y0	TRANSISTOR	2SC3419 Y
▲ Q703	HT332802A0	TRANSISTOR	2SC3280 (R. O)
▲ Q704	HT113012A0	TRANSISTOR	2SA1301 (R. O)
Q705	BA10007210	TRANSISTOR	DIGITAL DTA114ES
Q706	HT322401A0	TRANSISTOR	2SC2240 (GR)
▲ Q707	HT332802A0	TRANSISTOR	2SC3280 (R. O)
▲ Q708	HT113012A0	TRANSISTOR	2SA1301 (R. O)
▲ Q801	HC38105090	IC	NJM78L05A
▲ Q802	HC38115090	IC	NJM78L15A
▲ Q803	HC39115090	IC	NJM79L15A
<b>P701-MISCELLANEOUS</b>			
G801	BF47400010	CAP. COMP.	SPARK KILLER RFD2B474K
JS01	YT02020650	TERMINAL	2P RCA PIN JACK
JS02	YT02021180	TERMINAL	2P RCA PIN JACK
J701	YT01020190	TERMINAL	SPK. BROWN/RED
LN01	LY20240310	RELAY	VB24MBU
L701	ML08010030	AIR COIL	SPK CHOCK COIL
SU01	SR02020150	ROTARY SWITCH	SRBM12N-S15
XU01	F004004030	CERAMIC VIB.	CERALOCK CST4.00M GW