

Service Manual

74 MR2020 /2G (Layla)
MR2020 F,K,KK,U
CD/Tuner System



TABLE OF CONTENTS

SECTION	PAGE
MR2021 (CD/Tuner Amplifier)	
1 TECHNICAL SPECIFICATIONS	1-1
2-1 HOW TO DISASSEMBLE	2-1
2-2 REPAIR INTRODUCTION	2-6
2-3 EXPLANATION OF CIRCUITS	2-6
3 SERVICE MODE	3-1
4-1 BLOCK DIAGRAM	4-1
4-2 AM STEREO ADJ.(F ONLY)	4-1
4-3 MICROPROCESSOR DATA	4-1
5 WIRING DIAGRAM	5-1
6 SCHEMATIC DIAGRAM AND PARTS LOCATION	6-1
7B TUNER BOARD ECO5	7B-1
7D TUNER 95 BOARD	7D-1
8 CD NAMI 8 BOARD	8-1
9 EXPLODED VIEW AND PARTS LIST	9-1
10 ELECTRICAL PARTS LIST	10-1
LS2021 (Speaker System)	
1 EXPLODED VIEW AND PARTS LIST	1-1

CAUTION

The System MR2020 (Layla) combines MR2021 (CD/Tuner Amplifier) with LS2021 (Speaker System).

Please use this service manual with referring to the user guide (D.F.U.) without fail.

marantz®

system MR2020 / Layla

MARANTZ DESIGN AND SERVICE

Using superior design and selected high grade components, **MARANTZ** company has created the ultimate in stereo sound. Only original **MARANTZ** parts can insure that your **MARANTZ** product will continue to perform to the specifications for which it is famous.

Parts for your **MARANTZ** equipment are generally available to our National Marantz Subsidiary or Agent.

ORDERING PARTS :

Parts can be ordered either by mail or by Fax.. In both cases, the correct part number has to be specified.

The following information must be supplied to eliminate delays in processing your order :

1. Complete address
2. Complete part numbers and quantities required
3. Description of parts
4. Model number for which part is required
5. Way of shipment
6. Signature : any order form or Fax. must be signed, otherwise such part order will be considered as null and void.

USA

MARANTZ AMERICA, INC.
440 MEDINAH ROAD
ROSELLE, ILLINOIS 60172
USA
PHONE : 630 - 307 - 3100
FAX : 630 - 307 - 2687

CANADA

LENBROOK INDUSTRIES LIMITED
633 GRANITE COURT,
PICKERING, ONTARIO L1W 3K1
CANADA
PHONE : 905 - 831 - 6333
FAX : 905 - 831 - 6936

EUROPE /TRADING

MARANTZ EUROPE B. V.
P.O.BOX 80002
BUILDING SFF2
5600 JB EINDHOVEN
THE NETHERLANDS
PHONE : +31 - 40 - 2732241
FAX : +31 - 40 - 2735578

PROFESSIONAL USA

SUPERSCOPE TECHNOLOGIES, INC.
MARANTZ PROFESSIONAL PRODUCTS
2640 WHITE OAK CIRCLE, SUITE A
AURORA, ILLINOIS 60504 USA
PHONE : 630 - 820 - 4800
FAX : 630 - 820 - 8103

PROFESSIONAL CANADA

TC ELECTRONICS CANADA LTD.
540 FIRING AVE.
BAIE D'URFÉ, QUEBEC H9X 3T2
CANADA
PHONE : 514 - 457 - 4044
FAX : 514 - 457 - 5524

KOREA

MK ENTERPRISES LTD.
2F SHINHAN BLDG., 247-17 SEOKYO-DONG
MAPO-KU, SEOUL
KOREA
PHONE : +82 - 2 - 323 - 2155
FAX : +31 - 2 - 323 - 2154

BRAZIL

MARANTZ BRAZIL
CAIXA POSTAL 21462
CEP 04698-970
SAO PAULO, SP, BRAZIL
PHONE : 0800 - 123123(Discagem Direta Gratuita)
FAX : +55 11 534. 8988

THAILAND

MRZ STANDARD CO., LTD.
746 - 754 MAHACHAI RD.,
WANGBURAPAPIROM, PHRANAKORN,
BANGKOK, 10200 THAILAND
PHONE : +66 - 2 - 222 - 9181
FAX : +66 - 2 - 224 - 6795

AUSTRALIA / NEW ZEALAND

SCAN AUDIO PTY. LTD.
52 CROWN STREET, RICHMOND 3121
VICTORIA
AUSTRALIA
PHONE : +61 - 3 - 9429 - 2199
FAX : +61 - 3 - 9429 - 9309

TAIWAN

PAI-YUING CO., LTD.
6 TH FL NO, 148 SUNG KIANG ROAD,
TAIPEI, 10429, TAIWAN R.O.C.
PHONE : +886 (2) 5221304
FAX : +886 (2) 5630415

MALAYSIA

WO KEE HONG ELECTRONICS SDN. BHD.
NO. 102 JALAN SS 21/35, DAMANSARA
UTAMA, 47400 PETALING JAYA
SELANGOR DARUL EHSAN,
MALAYSIA
PHONE : +60 3 - 7184666
FAX : +60 3 - 7173828

JAPAN *Technical*

MARANTZ JAPAN, INC.
35- 1, 7- CHOME, SAGAMIONO
SAGAMIHARA - SHI, KANAGAWA
JAPAN 228-8505
PHONE : +81 42 748 1013
FAX : +81 42 741 9190

SINGAPORE

FORWARD MARKETING (S) PTE. LTD.
23, LORONG 8, TOA PAYOH,
SINGAPORE 319257.
PHONE : +65 2583640
FAX : +65 3564047

SHOCK, FIRE HAZARD SERVICE TEST :

CAUTION : After servicing this appliance and prior to returning to customer, measure the resistance between either primary AC cord connector pins (with unit NOT connected to AC mains and its Power switch ON), and the face or Front Panel of product and controls and chassis bottom.

Any resistance measurement less than 1 Megohms should cause unit to be repaired or corrected before AC power is applied, and verified before it is return to the user/customer.

Ref. UL Standard N0. 1492(DR700) and No. 813(CDR630).

In case of difficulties, do not hesitate to contact the Technical Department at above mentioned address.

1. TECHNICAL SPECIFICATIONS

FM Tuner

Frequency range	87.5 ~ 108.0 MHz
F only	76.0~ 90.0 MHz
Sensitivity	21.2 dBf / 3.2 μ V
S/N (Mono/Stereo)	75 / 43 dB
F only	70 / 50 dB
THD (Mono/Stereo)	1.5 / 1.5 %

MW Tuner

Frequency range	531 ~ 1602 kHz
U only	530 ~ 1700 kHz
Sensitivity	500 μ V / m
/02, F only	400 μ V / m
S/N	50 dB

LW Tuner

Frequency range	153 ~ 279 kHz
Sensitivity	1800 μ V / m

Amplifier

Music power	25 W + 25 W (4 Ω)
Input sensitivity (AUX)	310 mV / 47 k Ω
U only	250 mV / 47 k Ω
S/N (AUX)	85 dB

CD Player

Channels	2 channels
Frequency response	20 ~ 20,000 Hz \pm 3 dB
S/N	82 dB (1000 Hz)
THD	0.04 % (1000 Hz)
Output level	2 V RMS

General

Power supply	
/02 version	AC 230 V, 50 Hz
F version	AC 100 V, 50Hz / 60 Hz
K version	AC 110V / 220 V, 50Hz / 60 Hz
KK version	AC 220 V, 60 Hz
U version	AC 120 V, 60 Hz
Power consumption	25 W
Power failure backup time	APPROX. 15 min.
Dimensions	450(W) x 104(H) x 308(D) mm
Weight	5.8 kg

Table top Speaker LS2021

Speaker	
Mid-bass	4"
Dome tweeter	3/4"
Input power	
Rated	25 W (6 Ω)
Max.	40 W (6 Ω)
Frequency response	80 ~ 20,000 Hz \pm 6 dB
Dimensions	190(W) x 200(H) x 100(D) mm
Weight	1.5 kg

Design and specifications are subject to change without notice.

2-1. HOW TO DISASSEMBLE MR2020

1. Take the bottom case (001G) apart

- (1) Turn MR2020 upside down by the jig (Refer to fig.1-3).
Take care that the top cover will not be damaged, especially the 4 levers. If you don't have the jig, you prepare to put some magazine or telephone guide under the MR2020 (The height is over 3cm books).



Fig.1 A jig for MR2020



Fig.2 The jig on MR2020



Fig.3 Turning over the MR2020

- (2) Remove 15 screws as shown in fig.4.

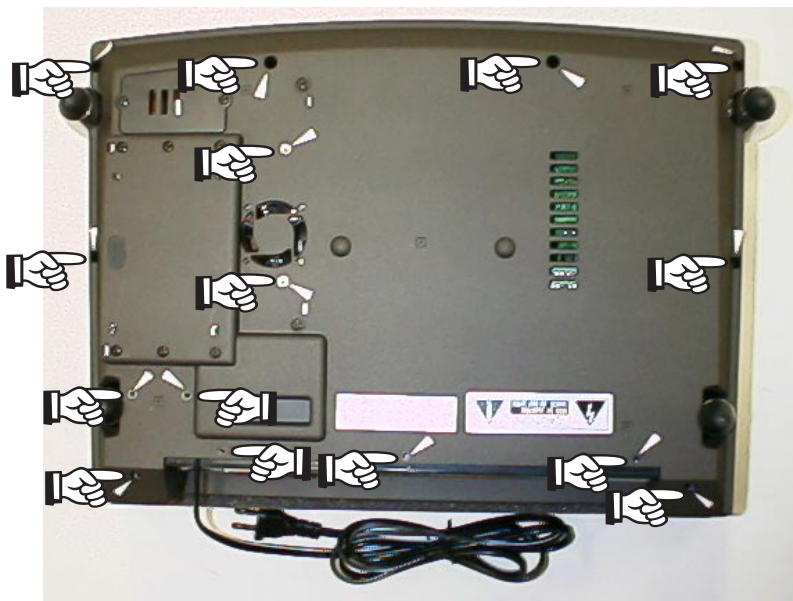

Fig.4 Position of 15 screws

- (3) While lifting the bottom case, remove the rear panel as shown in fig.5-6.



Fig.5 Lifting the bottom case



Fig.6 Removing the rear panel

- (4) Remove the mains code bush as shown in fig.7.

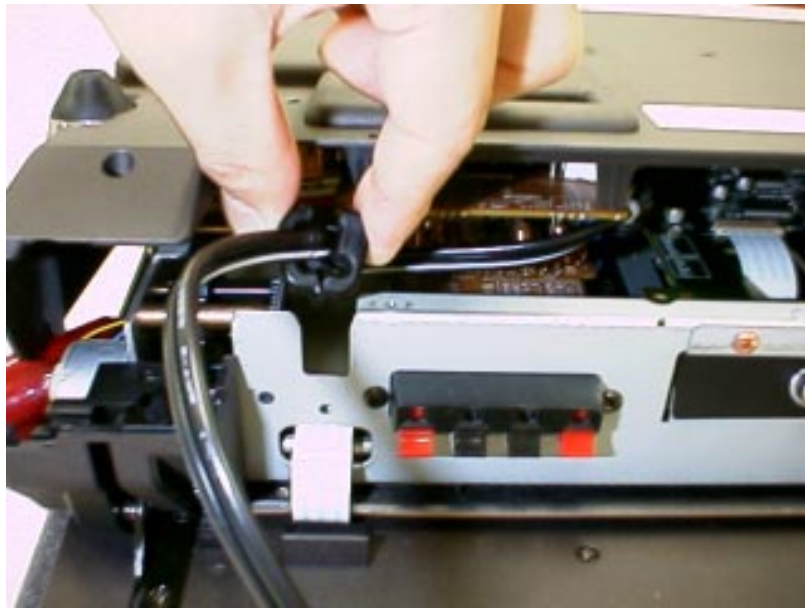

Fig.7 Removing the mains code bush

- (5) Lift up the bottom case, remove the put the one with turning to front side (Refer to fig.8).



Fig.8 Taking the bottom case apart

Remark for reassemble

When you fit the bottom case, remove the lid of the bottom case (Refer to fig.9) and confirm the arrangement of lead lines for transformer.(Refer to fig.10).



Fig.9 Removing the lid of the bottom case



Fig.10 Arrangement of lead lines

2. Take the top panel (001D) apart

- (1) Turn MR2020 upside down by the jig. (Refer to fig.1-3)
Take care that the top cover will not be damaged, especially the 4 levers. If you don't have the jig, you prepare to put some magazine or telephone guide under the MR2020. (The height is over 3cm books)
- (2) Push the rear panel while keeping hold the top cover (see fig.11 below). The top cover will move 5mm. (fig.12-13)
Now, 4 screws on the top cover will become accessible. (fig.14) Take out these screws. (M3 type screw)



Fig.11 Pushing the rear panel



Fig.12 Before pushing the rear panel



Fig.13 Pushed the rear panel

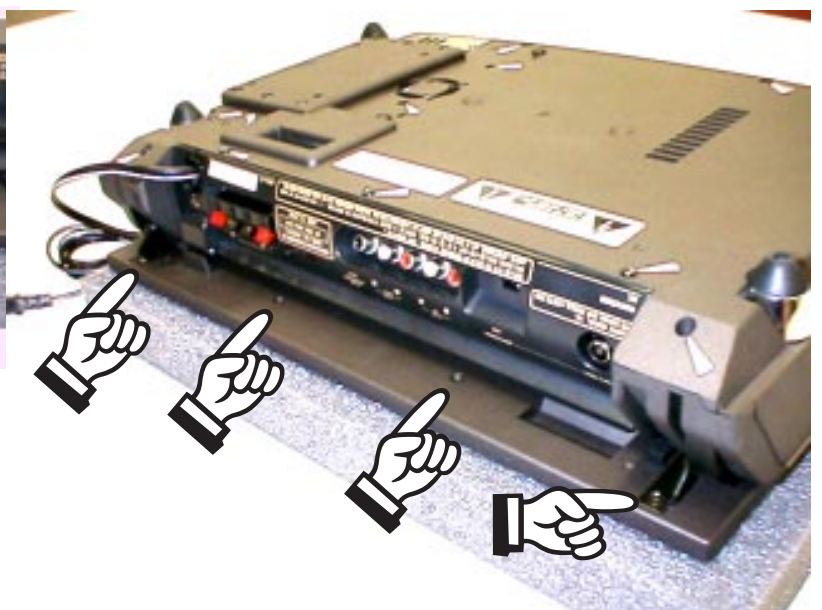

Fig.14 Positions of 4 screws

- (3) Turn the MR2020 to its normal operating position.
- (4) Open the top cover of MR2020 by hand.
- (5) Take out the 2 screws (M2 type screw) on the top (see fig.15).



Fig.15 Positions of 2 screws on the top

- (6) The upper part and lower part of the top cover are connected to each other with adhesive tape. Separate these parts by pushing the transparent upper part in the middle (on CD shaped part) from the lower part, while holding the lower part.
- (7) The upper part and lower part of the top cover were separated (See fig.16-17).



Fig.16 The upper part of top cover (the reverse side)



Fig.17 The lower part of top cover and the others

2-2. REPAIR INTRODUCTION

PREPARATION FOR CD BLOCK

1. Set a disc for repair into product.
2. Turn the product upside down on the jig (Parts No.*MR2021JIG). Take care that the top cover will not be damaged, especially the 4 levers. (Refer to "How to disassemble MD2020")
3. For the top panel will not open while repairing, remove the connecting wires of panel motor from the connector (J812).
4. Repair and operate it on the upside down position of the product.

PREPARATION FOR MAIN AMPLIFIER PCB (P704)

1. Main amplifier is BTL output.
2. For removing the main amplifier PCB (P704) from the product, remove the wire (W802) from the terminal (WU02) of microprocessor PCB (PU04). Connect another wire with terminal (WU02) and GND as chassis instead of the wire (W802).

REMARK

Remove the bottom case from the product, Do not output signals of over 1W from both channels more than 10 minutes continuously.

2-3. EXPLANATION OF CIRCUITS

FAN OPERATION

The voltage added to the diode (D852) is depended on the resistance of the thermistor (R857) and resistors (R855,R858). When the temperature of the heat sink goes up, the resistance of the thermistor (R857) decreases, and the voltage added to the diode (D852) increases.

1. When the temperature of the heat sink is over 70 degrees Celsius, then D852 is on, through R852, Q851 is on, and the fan starts to revolve.
2. When the temperature of the heat sink is approx. 100 degrees Celsius or more, through R853, Q853 is on, and the product is STAND-BY status. But, if the fan revolve normally, the temperature of the heat sink will not be over 100 degrees Celsius and not be STAND-BY status. Therefore, the procedure of the over heat protection circuit check is as follows;
 - (1) Connect the test point (J814) with a resistor of 680 ohm.
 - (2) If the product is STAND-BY status, this circuit is normal.
 - (3) Remove the resistor of 680 ohm from the test point (J814).

FAN OPERATION CHECK

Keep outputting 2.5W from both channels of the product.

When the bottom case is closing. If the fan revolving starts within 10 minutes, the function is correct working.

Otherwise keep outputting 1W from both channels of the product when the bottom case is opening. If the fan revolving starts within 5 minutes, the function is correct working.

REMARK

Do not output over 1W when the bottom case is open.

VCC CONTROL

The regulation of primary voltage is not so higher intentionally for decreasing the no-load loss. Therefore, this circuit is used for the product to keep the voltage tolerance of the power IC. This circuit do not work when the output is from 0 to approx. 1Vrms. Then VCC is supplied from D709 only. When the output is more than 1Vrms, through D701-D704, R722, D706, and Q703 is on, current is supplied from Q702. When the output is over approx. 3Vrms, D709 is off, and VCC is supplied from Q702 only.

SPEAKER PROTECTION

1. When either terminal of BTL outputs connect with GND (chassis) by mistake, the speaker protection circuit will work as follows. through R707-R710, Q704 or Q705 is on, and Q706 is on. Then #5Pin for Q701 is 0V, power IC (Q701) will be in power off. Therefore, the product will be STAND-BY status.
2. When the VCC CONTROL circuit is working correctly, maximum current of R825 is 1A, and voltage between R825 load is maximum 0.33V. When both terminals of BTL outputs are shorted on outputting over 0.25W, R825 is supplied over 2A, Q807 and Q803 is on, and the product will be STAND-BY status.

CD 5V ON/OFF CONTROL

The voltage for CD (CD 5V) is supplied from QX04 when the following conditions are satisfied fully. (for noise and laser protection)

1. Setting a disc on the product, and QU08 is on.
2. Closing top panel, and #78Pin for QU10 is 0V.
3. The product is in CD mode.

MUTE CONTROL

Mute signals output from microprocessor (QU10) are "MUTE (Pin No.37)", "MUTE2 (Pin No.7)", and "DSC MUTE (Pin No.5)".

Fig.1 is workable output terminals by each mute signals, Fig.2 is the status of each mute.

Fig.1

	Q701(SPK)	QN01-QN04 (PHONE)	QX05,QX06 (SUB WOOFER)	QX07,QX08 (LINE OUT)	QE01
MUTE	YES	YES	YES	NO	NO
MUTE2	NO	NO	NO	YES	NO
DSC MUTE	NO	NO	NO	NO	YES

Fig.2

	POWER ON/OFF	CD MODE STOP OR TRACK JUMP	MUTE BUTTON ON	MODE CHANGE	VOLUME MINIMUM
MUTE	YES	YES	YES	YES	YES
MUTE2	YES	YES	NO	YES	NO
DSC MUTE	NO	YES	NO	NO	NO

TOP PANEL OPEN SENSOR

1. The pulse (T=84msec, Duty 50%) is always added to LED (QU15), from #30Pin of QU10, through RF28 and QU22.
2. Cover the sensor with your fingers, the collector voltage of QU01 goes up over 0.7VP-P and through RU71 and QU09, the pulse of 5VP-P inputs to #29Pin of QU10. Then the top panel will open.
3. Not needing to cover the sensor with your fingers, QU01 receives the light of LED reflected by lens oneself. Therefore, the collector of QU01 adds the reverse pulse through RF29, QU26 and RF32, for reduced incorrect working. So, the voltage of residual pulse for the collector of QU01 is suppressed to 0.1VP-P.

REMARK

When the sensor receives sunlight or a strong light as incandescent, top panel might open.

POPS NOISE KILLER

RX72, CX70 and QX70 are the circuit to delay power supply for approx. 2 seconds. Therefore, this circuit prevents pops noise generation when power switch is on or off.

SUB WOOFER

Sub woofer output is composed a low pass filter of cut-off frequency 150Hz octave 12dB. It is output 2V for AUX L,R input 60Hz, 200mV (volume is maximum).

REMARK

Sub woofer output level is depended on volume control.

3 SERVICE MODE

1. How to set the service mode

- (1) While holding the CLOCK and CLEAR buttons together, put the mains plug to mains outlet.
- (2) FL check mode will start.
- (3) While in FL check mode, each time the FUNCTION button pressed (within 2 seconds), the mode changes in the following order.
TR FREQ (Tracking point frequency memory mode) → CD TEST (CD test mode) → FL CHK (FL check mode) → TR FREQ (Tracking point frequency memory mode)

2. FL CHECK MODE

FL check mode will continue until change other mode.

3. TRACKING POINT FREQUENCY MEMORY MODE

This mode is not available for repair(This is for check in factory.). If you set in this mode, some frequencies will register in each preset memory.

REMARK

User programmed frequencies will be deleted.

While in Tracking point frequency memory mode, press the MEMO button. Press the CLEAR and the DISPLAY buttons together. The display shows "CLEAR" 2 seconds. Then all memories will be clear.

4. CD TEST MODE

- (1) Press the "+" button, then the sledge move to the outside. Press the "-" button then the sledge move to the inside. Press the CLEAR button while the sledge is moving, then the sledge stop.
- (2) Press the MEMO button, then the laser pick up unit is giving out the beam. Press the MEMO button again then the laser pick up unit stop beam out. All operations are available without the Disc.
- (3) While in CD test mode, CD play is available in opening the top panel.
- (4) If any ERROR is happened, the display shows "CD ERRX". (X is a ERROR code.) The ERROR message will not be clear until pressing STOP or POWER buttons.

Error Code	Description
1	The sledge switch not turn on.
2	The sledge switch not turn off.
3	The laser pick up unit not focus.
4	The tracking is not fixed.
5	The spindle motor not locked.

エラーコード	エラーの詳細
1	スレッジのスイッチがONしない
2	スレッジのスイッチがOFFしない
3	フォーカスが合わない
4	トラッキングが合わない
5	スピンドルモーターがロックしない

5. How to stop the service mode

Press the POWER button. Then product will be in POWER OFF (STAND-BY).

REMARK

The microprocessor will not be clear by this operation.

(Refer to "3. TRACKING POINT FREQUENCY MEMORY MODE")

4-1 BLOCK DIAGRAM

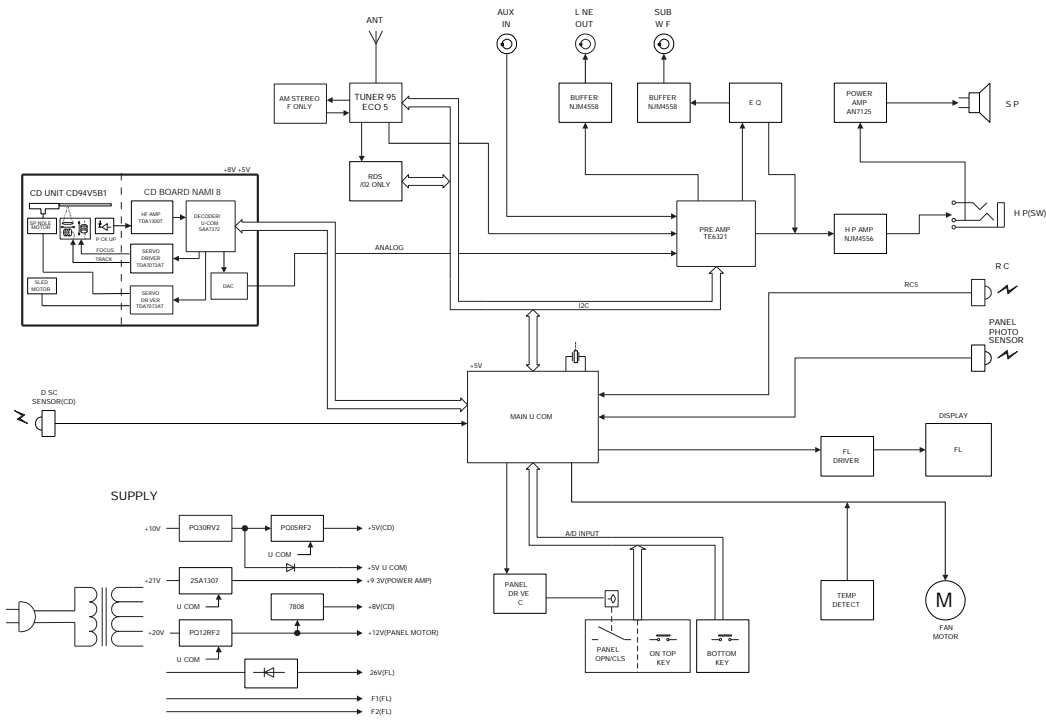

4-3 MICROPROCESSOR DATA

Pin No	Pin Name	Signal Name	I/O	Active	Slow	Function
1	P10 (IN10)	PDW_DWN	INT	L	L	POWER DOWN
2	P11 (IN11)	STANDBY	OUT	L	L	POWER STANDBY
3	P12 (IN12)	SDA	NI/OUT	L	L	I ² C SDA(w/ RDS DSC)
4	P13 (DV0)	SC	OUT	H	L	I ² C SCL(w/ RDS DSC)
5	P14	RSC_MUTE	OUT	L	L	RSC_MUTE
6	P15	CD_STANDBY	OUT	L	L	CD STANDBY
7	P16	MUTE2	OUT	L	L	LINE MUTE
8	P17	-	N	-	-	N/C
9	TEST	-	N	-	-	TEST
10	P21 (XTIN)	32.768KHz	IN	-	-	SUB XTAL
11	P22 (XTOUT)	32.768KHz	OUT	-	-	SUB XTAL
12	RESET	RESET	N	L	L	RESET
13	XIN	80MHz	IN	-	-	X TAL
14	XOUT	80MHz	OUT	-	-	X TAL
15	RCS	SEND	OUT	-	-	RCS
16	P20 (INT5)	HOLD	IN	L	L	HOLD IN
17	P30 (INT3)	RCIN	INT	T	L	RC-5 BUS IN
18	P31	RSOUT	OUT	L	L	RC-5 BUS OUT
19	P32 (SCK)	LINE_CLK	OUT	H	L	TUNER CLK
20	P33 (S0)	TUNE_WE	OUT	L	L	TUNER WRITE ENABLE
21	P34 (S0)	TUNE_SDR	IN/OUT	H	L	TUNER SW
22	P35 (HSCK)	TUNER_ST_MON	IN	H	L	TUNER STEREO MONO
23	P36	CD7 RESET	OUT	L	L	CD7 RESET
24	P37 (RSC)	RSC_IN	IN	H	-	RSC IN SENSOR
25	P00	S/D	OUT	L	L	CD7 CONTROL
26	P01	RAB	OUT	H	L	CD7 CONTROL
27	P02	SC	IN	H	L	CD7 CONTROL
28	P03	SDA	IN/OUT	H	L	CD7 CONTROL
29	P04	P_SEN_IN	N	H	-	PANEL SENSOR IN
30	P05	P_SEN_OUT	OUT	H	L	PANEL SENSOR OUT
31	P06	P_MOTOR_P	OUT	H	L	PANEL MOTOR
32	P07	P_MOTOR_N	OUT	H	L	PANEL MOTOR
33	VDD	+5V	-	-	-	VDD
34	P01 (G15)	-	IN	-	-	N/C
35	P01 (G14)	-	IN	-	-	N/C
36	P02 (G13)	AMPON	OUT	H	L	AMP POWER ON
37	P03 (G12)	MUTE	OUT	H	L	MUTE
38	P04 (G11)	RDS_ON	OUT	H	L	RDS POWER
39	P05 (G10)	TTG	OUT	H	L	DIGIT OUT
40	P06 (G9)	TRG	OUT	H	L	DIGIT OUT

Pin No	Pin Name	Signal Name	I/O	Active	Slow	Function
41	P07 (G8)	SG	OUT	H	-	DIGIT OUT
42	P70 (G7)	8G	OUT	H	-	DIGIT OUT
43	P71 (G6)	7G	OUT	H	-	DIGIT OUT
44	P72 (G5)	6G	OUT	H	-	DIGIT OUT
45	P73 (G4)	5G	OUT	H	-	DIGIT OUT
46	P74 (G3)	4G	OUT	H	-	DIGIT OUT
47	P75 (G2)	3G	OUT	H	-	DIGIT OUT
48	P76 (G1)	2G	OUT	H	-	DIGIT OUT
49	P77 (G0)	1G	OUT	H	-	DIGIT OUT
50	P80 (S0)	P16	OUT	H	-	SEGMENT OUT
51	P81 (S1)	P15	OUT	H	-	SEGMENT OUT
52	P82 (S2)	P14	OUT	H	-	SEGMENT OUT
53	P83 (S3)	P13	OUT	H	-	SEGMENT OUT
54	P84 (S4)	P12	OUT	H	-	SEGMENT OUT
55	P85 (S5)	P11	OUT	H	-	SEGMENT OUT
56	P86 (S6)	P10	OUT	H	-	SEGMENT OUT
57	P87 (S7)	P9	OUT	H	-	SEGMENT OUT
58	P90 (S8)	P8	OUT	H	-	SEGMENT OUT
59	P91 (S9)	P7	OUT	H	-	SEGMENT OUT
60	P92 (S10)	P6	OUT	H	-	SEGMENT OUT
61	P93 (S11)	P5	OUT	H	-	SEGMENT OUT
62	P94 (S12)	P4	OUT	H	-	SEGMENT OUT
63	P95 (S13)	P3	OUT	H	-	SEGMENT OUT
64	P96 (S14)	P2	OUT	H	-	SEGMENT OUT
65	P97 (S15)	P1	OUT	H	-	SEGMENT OUT
66	VXX	B	IN	-	-	Power Supply for FL
67	P40 (KEY0)	Key0	IN	H	-	Key0
68	P41 (KEY1)	Key1	IN	H	-	Key1
69	P42 (KEY2)	Key2	IN	H	-	Key2
70	P43 (KEY3)	Key3	IN	H	-	Key3
71	P44 (KEY4)	Key4	IN	H	-	Key4
72	P45 (KEY5)	Key5	IN	H	-	Key5
73	P46 (KEY6)	Key6	IN	H	-	Key6
74	P47 (KEY7)	Key7	IN	H	-	Key7
75	P51 (A/D)	DMVN	N	L	-	RDS PSWN
76	P51 (A/D)	PSWN	N	L	-	RDS PSWN
77	P52 (A/D)	P_OPEN	N	L	-	PANEL SW OPEN
78	P53 (A/D)	P_CLOSE	N	L	-	PANEL SW CLOSE
79	P54	VER_SETO	IN	-	-	0 P 1 0 K K 1 / 2
80	P55	VER_SET1	IN	-	-	0 P 1 0 K K 1 / 2

5. WIRING DIAGRAM

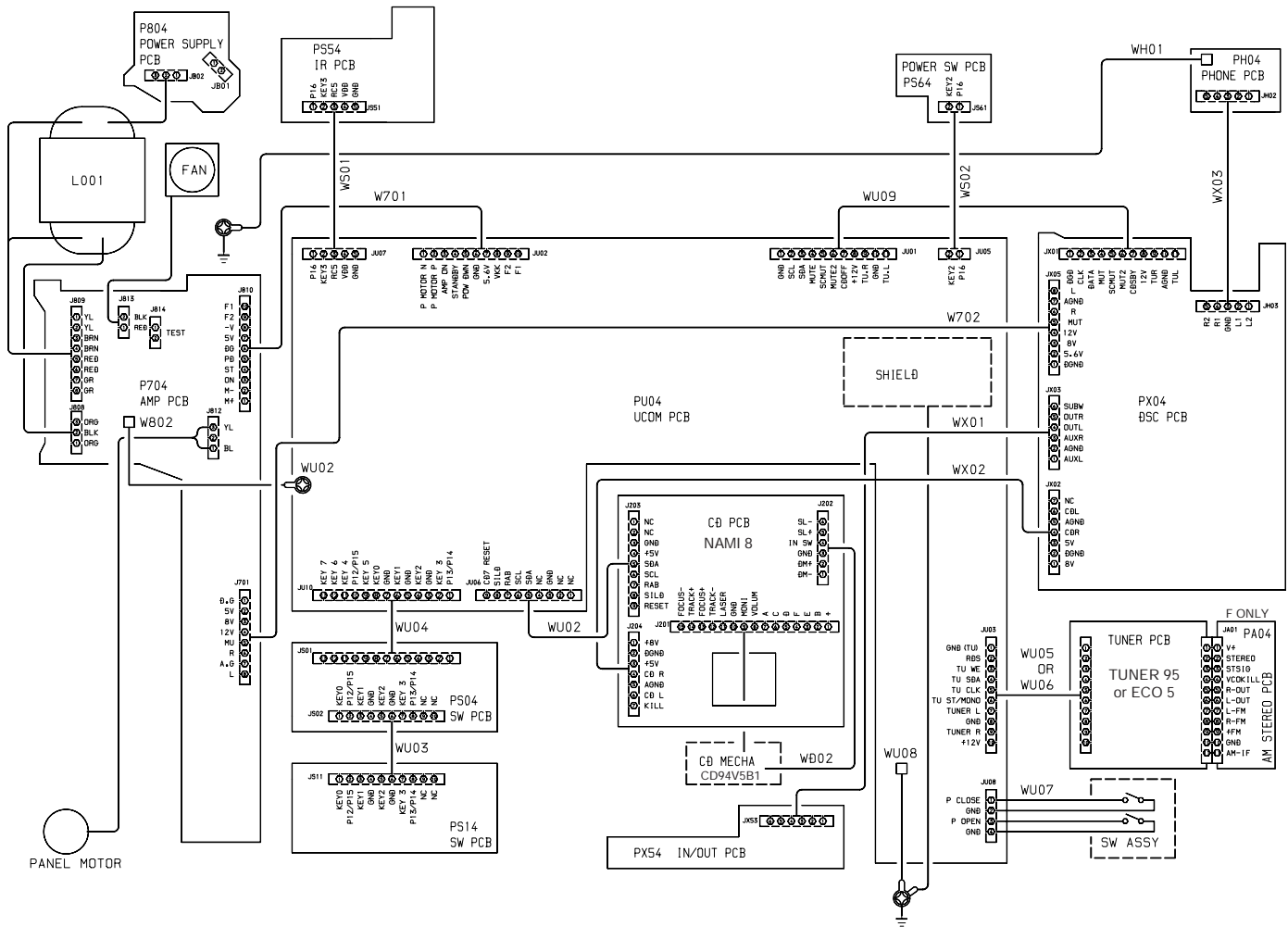

6. SCHEMATIC DIAGRAM AND PARTS LOCATION

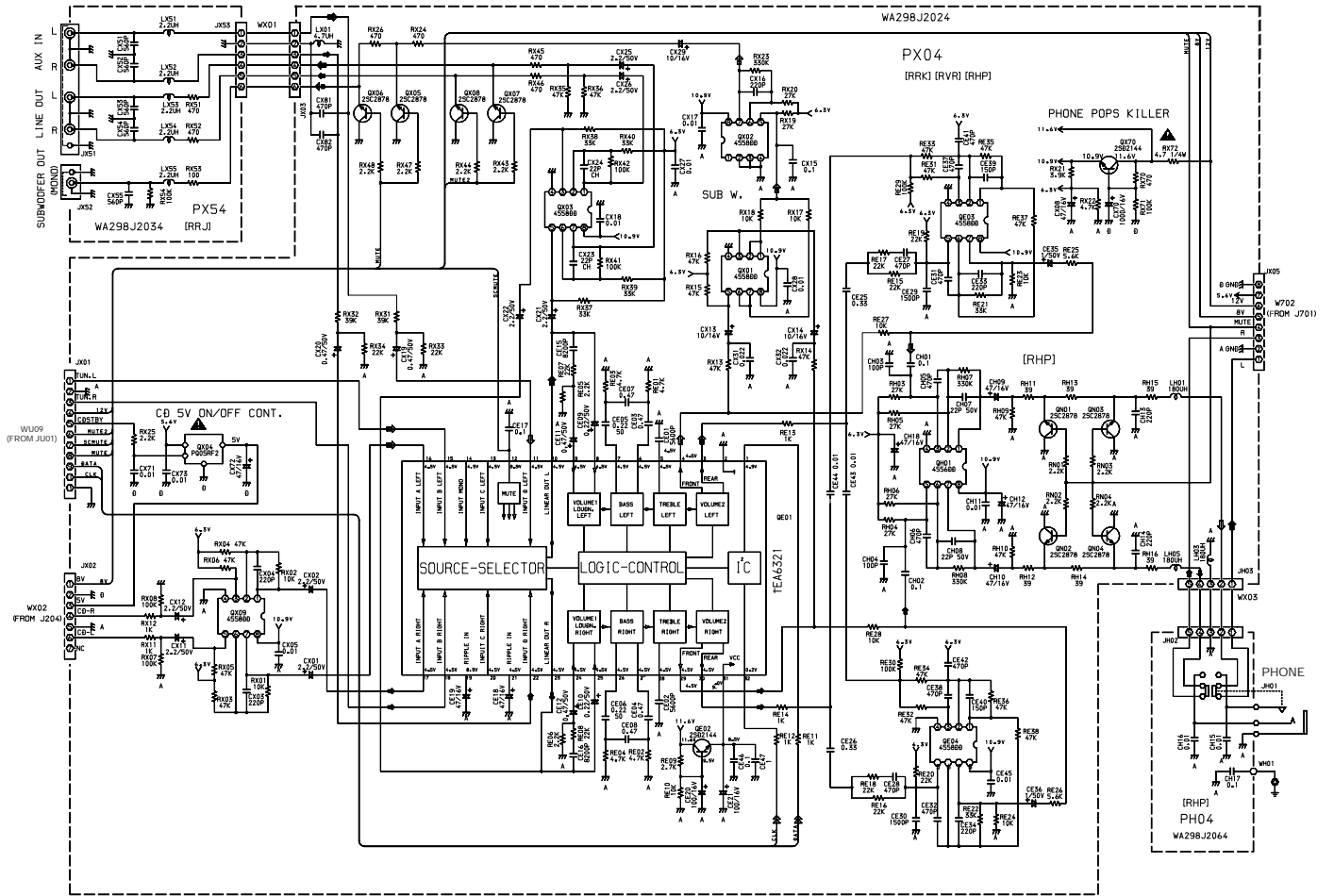

P704

Q708

Q707 Q701
Q705 Q704 Q706

Q702
Q703

Q801

Q805

Q806

QD01 Q853
Q852 Q851 Q803 Q807

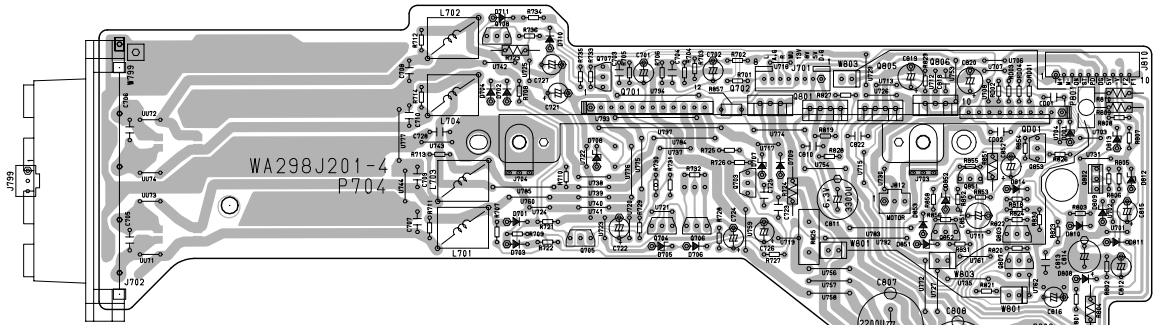

PX04 QN03 QN01 QH01 QE04 QE03
 QN04 QN02
 QX07 QX03 QX08 QE04 QE02
 QX70 QX04 QX01 QX02 QX05 QX06 QX09

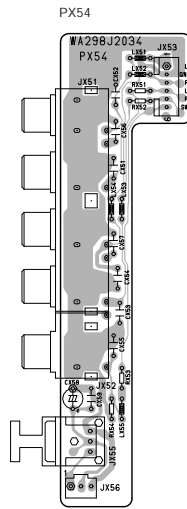
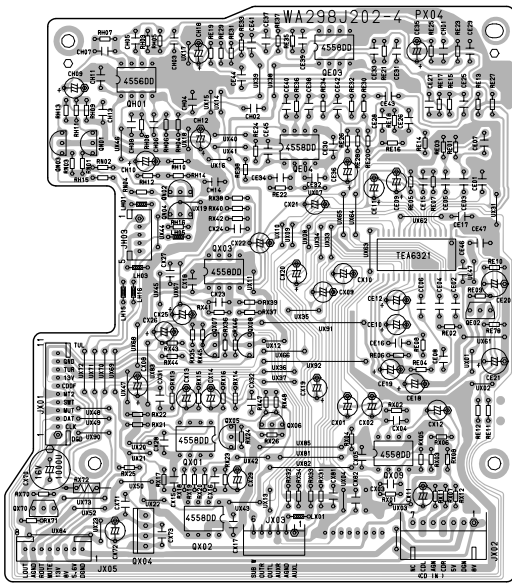

P804

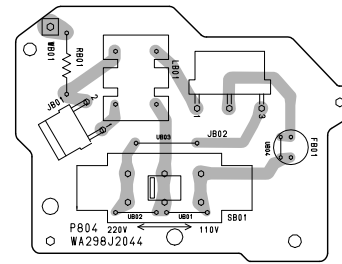

PH04

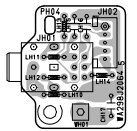

PU04

QU12 QU13 QU14 QU15 QU22 QU26 QU09 QU10
 QU04 QU03 QU08 QU28 QU27 QU25 QU24 QU23

QU21 QU16 QU17 U28
 QU06 QU07 QU05 QU18 QU19 QU20 QF51

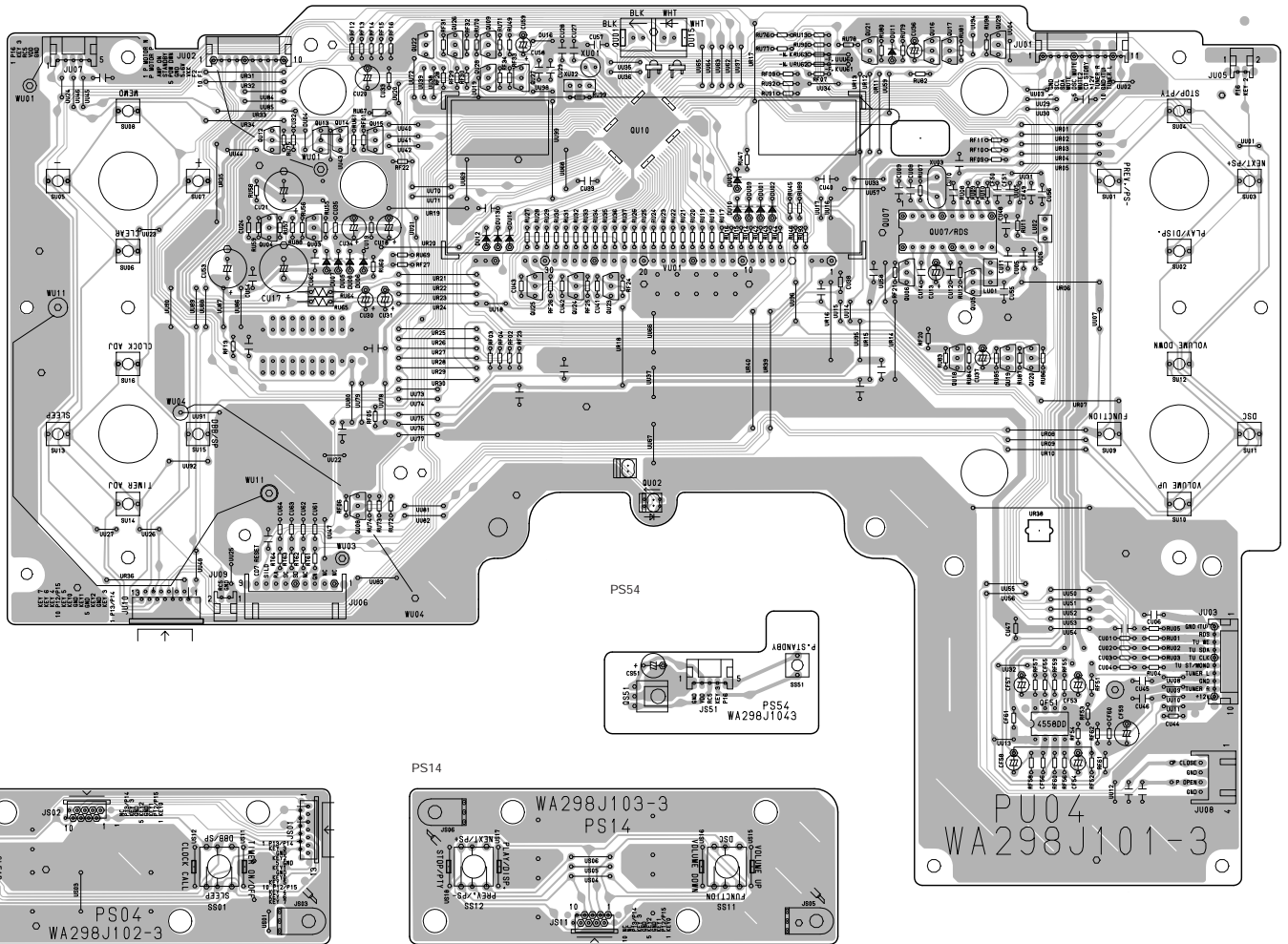

PS04

PS14

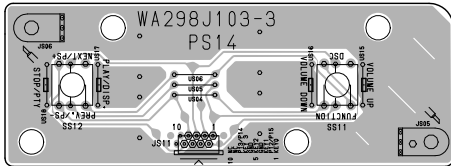
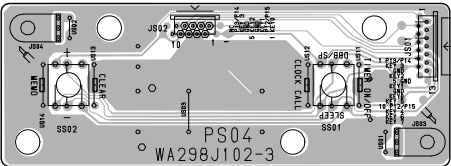
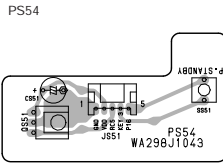

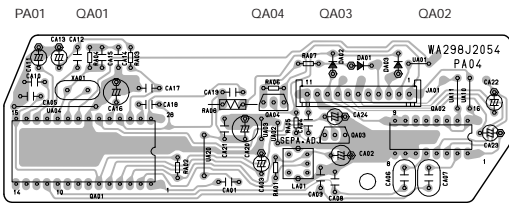
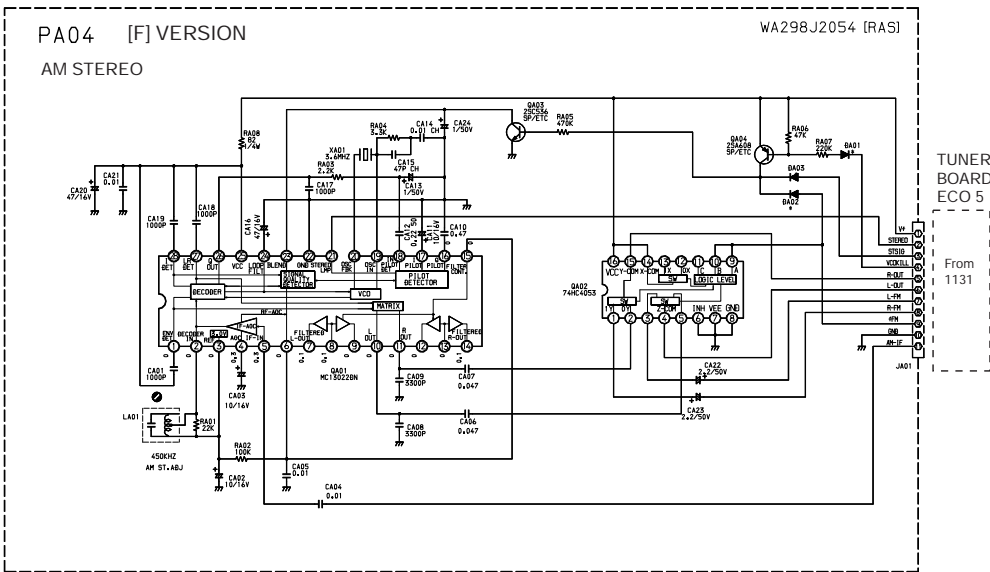

BLOCK DIAGRAM

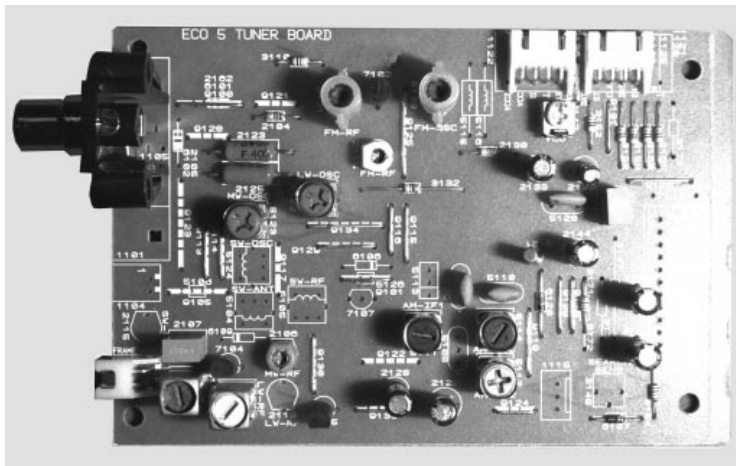
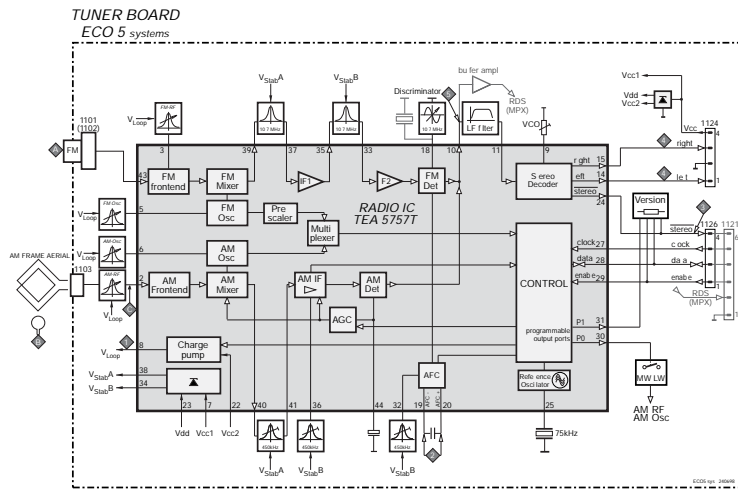

TUNER BOARD ECO5

TABLE OF CONTENTS

Blockdiagram 7B-1
 Adjustmant table 7B-2
 Component layout..... 7B-3
 Circuit diagram..... 7B-4
 Parts list 7B-5

TUNER ADJUSTMENT TABLE (ECOS FMMW- and FMMW/LW- versions with AM-frame aerial)

Waverange	Input frequency	Input	Tuned to	Adjust	Output	Scope/Voltmeter
VARICAP ALIGNMENT						
FM 87.5 - 108MHz (65 81 74 875 108MHz)			108MHz	5130	1	8V ±0.2V
			87.5MHz (65 81MHz)	check		4.3V ±0.5V (1.2V ±0.5V)
MW FMMW version 10kHz grid 530 - 1700kHz			1700kHz	5123	1	8V ±0.2V
			530kHz	check		1.1V ±0.4V
FMMW version 9kHz grid 531 - 1602kHz			1602kHz	5123	1	6.9V ±0.2V
			531kHz	check		1.1V ±0.4V
LW 153 - 279kHz			279kHz	5122	1	8V ±0.2V
			153kHz	check		1.1V ±0.4V
MW FMMW/LW version 9kHz grid 531 - 1602kHz			1602kHz	5123	1	8V ±0.2V
			531kHz	check		1.1V ±0.4V
FM IF						
FM	10.7MHz, 50mV continuous wave	F	IC 7101 short circuit to block AFC 21	5119	2	0 ± 3 mV DC
FM RF						
FM 87.5 - 108MHz (65 81 74 875 108MHz)	108MHz	A	108MHz	2155	4	MAX
			87.5MHz (65 81MHz)	mod=1kHz Δf=±22.5kHz		
FM Japan 76 - 90MHz plus Ch1 95.75MHz Ch2 101.75MHz Ch3 107.75MHz	107.75MHz	mod=1kHz Δf=±22.5kHz	76MHz	5131	4	MAX
VCO						
FM	98MHz, 1mV continuous wave	A	98MHz	3142	3	152kHz ±1kHz ¹⁾
AM IF						
MW	450kHz connect pin 6 of IC 7101 (AM Osc.) with short wire to ground (pin 4)	C	IC 7101 36 100nF	5111	4	
			IC 7101 40 100nF	5112		
AM AFC MW		C	continuous wave V _{RF} = 10mV	5114	2	0 ± 2 mV DC
AM RF³⁾						
MW ⁴⁾ FMMW/LW and FMMW (9kHz grid) 531 - 1602kHz	1494kHz	B	1494kHz	2106	4	
	558kHz		558kHz	5102		
LW	198kHz		198kHz	5103		
MW FMMW version 10kHz grid 530 - 1700kHz	1500kHz	B	1500kHz	2106	4	
	560kHz		Δf = ±30kHz V _{RF} as low as possible	560kHz		

Use service test program. By selecting the TUNER TEST test frequencies will be stored as preset frequencies automatically.
¹⁾ If sensitivity of frequency counter is too low adjust to max. channel separation on (input signal stereo left 90% + 9% adjust output on right channel to minimum)
²⁾ RC network serves for damping the IF filter while adjusting the other one
³⁾ For AM RF adjustments the original frame antenna has to be used!
⁴⁾ MW has to be aligned before LW
 Repeat

TUNER ADJUSTMENT TABLE (ECOS FMMW- stereo versions with AM-frame aerial)

Waverange	Input frequency	Input	Tuned to	Adjust	Output	Scope/Voltmeter
VARICAP ALIGNMENT						
FM 87.5 - 108MHz			108MHz	5130	1	8V ±0.2V
			87.5MHz	check		4.3V ±0.5V
FM Japan 76 - 90MHz plus Ch1 95.75MHz Ch2 101.75MHz Ch3 107.75MHz			107.75MHz	5130	1	8V ±0.2V
			76MHz	check		2.4V ±0.5V
MW FMMW version 10kHz grid 530 - 1700kHz			1700kHz	5123	1	8V ±0.2V
			530kHz	check		1.1V ±0.4V
MW FMMW version 9kHz grid 531 - 1602kHz			1602kHz	5123	1	6.9V ±0.2V
			531kHz	check		1.1V ±0.4V
FM IF						
FM	10.7MHz, 50mV continuous wave	F	IC 7101 short circuit to block AFC 21	5119	2	0 ± 3 mV DC
FM RF						
FM 87.5 - 108MHz	108MHz	A	108MHz	2155	5	MAX
			87.5MHz	87.5MHz		
FM Japan 76 - 90MHz plus Ch1 95.75MHz Ch2 101.75MHz Ch3 107.75MHz	107.75MHz	mod=1kHz Δf=±22.5kHz	76MHz	5131	5	MAX
VCO						
FM	98MHz, 1mV (83MHz for Japan) continuous wave	A	98MHz (83MHz for Japan)	3142	3	152kHz ±1kHz ¹⁾
AM IF						
MW	450kHz connect pin 6 of IC 7101 (AM Osc.) with short wire to ground (pin 4)	C	IC 7101 36 100nF	5111	5	
			IC 7101 40 100nF	5112		
AM AFC MW		C	continuous wave V _{RF} = 10mV	5114	2	0 ± 2 mV DC
IF stereo module MW		E	100nF 100nF	5240	4	
AM RF³⁾						
MW FMMW version 9kHz grid 531 - 1602kHz	1494kHz	B	1494kHz	2106	4	
	558kHz		558kHz	5102		
MW FMMW version 10kHz grid 530 - 1700kHz	1500kHz	B	1500kHz	2106	4	
	560kHz		Δf = ±30kHz V _{RF} as low as possible	560kHz		

Use service test program. By selecting the TUNER TEST test frequencies will be stored as preset frequencies automatically.
¹⁾ If sensitivity of frequency counter is too low adjust to max. channel separation on (input signal stereo left 90% + 9% adjust output on right channel to minimum)
²⁾ RC network serves for damping the IF filter while adjusting the other one
³⁾ For AM RF adjustments the original frame antenna has to be used!
 Repeat

1101 A1	2106 C2	2137 C5	3149 C5	5173 A5	5114 C4	5130 A3	7104 C2	9117 B2	9129 B3
1102 A1	2107 C2	2138 A5	3152 A5	5102 C2	5115 A4	5131 A3	7105 C3	9118 B4	9130 C3
1103 C1	2110 C2	2144 B5	3154 C5	5103 C2	5116 A4	6101 A2	7107 B3	9119 C4	9131 A5
1104 B1	2115 C1	2148 B4	3157 B5	5104 C2	5119 B5	6102 A1	7119 C4	9120 B4	9133 C3
1105 A1	2123 A2	2155 A3	3158 A5	5105 B2	5120 B4	6103 A1	9100 A2	9121 A2	9134 B3
1119 C5	2125 A2	2162 A2	3159 A5	5106 B2	5121 B4	6104 A2	9101 B3	9122 C3	9136 A5
1120 A5	2128 C3	3105 B3	3160 A5	5109 B4	5122 B3	6106 B3	9105 B2	9123 B1	9137 A5
1130 B5	2129 C4	3110 A2	3161 A5	5110 B4	5123 B2	6107 C5	9111 C2	9124 C4	
1131 B5	2130 A4	3132 B3	3170 C5	5111 C3	5124 B2	6109 C2	9113 B2	9125 A3	
2104 A2	2133 A4	3142 A4	3171 C5	5112 C4	5125 B3	6120 C4	9114 B2	9126 B5	
2105 A1	2135 B5	3147 B5	3172 C5	5113 B3	5127 B4	7102 A3	9115 B3	9128 A2	

2101 C4	2118 B4	2139 B2	2153 C3	2166 B2	3112 A3	3123 A3	3143 C2	3175 A2	4105 B3	4153 B4	6105 A4	7120 B4
2102 C4	2119 B4	2141 B1	2154 C3	2167 B2	3113 A2	3125 A3	3144 C2	3176 C2	4106 B4	4154 C3	6110 A4	7121 B3
2103 C3	2120 B4	2142 B1	2156 C4	2168 B1	3114 A3	3126 B3	3145 C2	3177 A1	4107 C4	4155 A4	6111 B4	7122 B4
2108 A4	2122 B3	2143 A1	2157 B4	3101 C3	3115 A3	3127 B3	3146 A1	3178 A1	4108 B4	4156 A2	6130 C2	7123 B4
2109 A4	2124 A5	2145 C1	2158 B4	3102 C3	3116 A3	3128 B3	3148 A1	3179 A1	4109 A3	4157 B3	6131 C3	7124 C4
2111 A3	2126 C2	2146 C1	2159 C2	3103 C3	3117 B4	3133 B4	3153 C2	3180 A4	4110 A3	4158 C2	7101 B2	7125 A1
2112 B5	2127 C2	2147 C1	2160 C4	3104 B3	3118 B3	3134 B4	3155 A2	3181 C3	4111 C1	4159 A2	7103 C2	
2113 A4	2131 C2	2149 B2	2161 A3	3106 C4	3119 A3	3136 B4	3156 A1	4101 A4	4120 C2	4160 A1	7106 A3	
2114 A4	2132 C1	2150 B2	2163 A2	3108 A4	3120 B4	3137 B4	3167 C2	4102 A4	4150 B2	4161 A1	7108 A3	
2116 B3	2134 C1	2151 C2	2164 B1	3109 A4	3121 A3	3140 B2	3168 B3	4103 C2	4151 B3	4162 C1	7109 A3	
2117 A3	2136 B1	2152 C3	2165 B3	3111 A3	3122 B3	3141 C2	3169 B2	4104 A2	4152 B3	4163 C1	7111 A1	

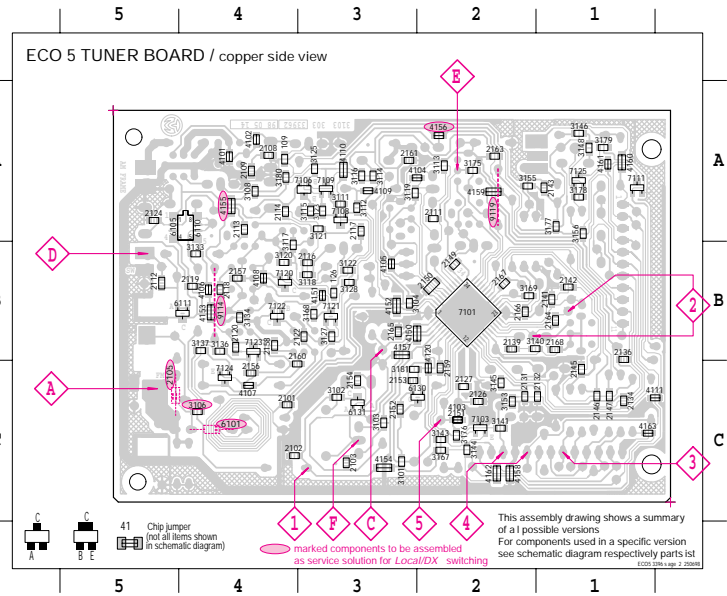
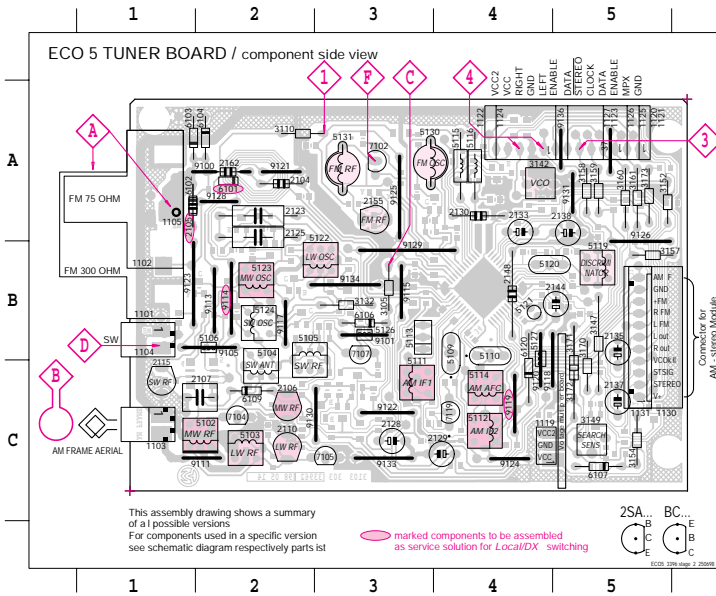

ELECTRICAL PARTSLIST *TUNER ECO5*

MISCELLANEOUS

1101	4822 267 31505	SOCKET 2-POLE CLICKFIT, 300Ω	only for /17
1102	4822 267 10283	SOCKET COAX, IEC 75Ω	not for /17

CAPACITORS

2101	© 5322 122 32531	100pF	5%	50V	not for /17
2101	© 5322 122 32452	47pF	5%	63V	only for /17
2102	© 4822 122 33177	10nF	20%	50V	
2103	© 5322 122 34123	1nF	10%	50V	
2104	4822 122 33195	100pF	10%	50V	

2106 4822 125 60101 3-11pF TRIMCAP.

2107	4822 121 51319	1μF	20%	50V	
2120	© 5322 122 32658	22pF	5%	50V	
2125	4822 121 51381	560pF	1%	400V	
2126	© 5322 122 31863	330pF	5%	50V	

2127	© 4822 126 13473	220nF	20%	50V	
2128	4822 124 41579	10μF	20%	50V	
2129	4822 124 41584	100μF	20%	10V	
2130	4822 126 11585	22nF	20%	50V	
2131	© 4822 126 13482	470nF	20%	16V	

2132	© 4822 126 13482	470nF	20%	16V	
2133	4822 124 40242	1μF	20%	63V	
2134	© 4822 126 13188	15nF	5%	63V	not for /17
2134	© 5322 122 32654	22nF	10%	63V	only for /17
2135	4822 124 40746	0,22μF	20%	63V	

2136	© 4822 126 13188	15nF	5%	63V	not for /17
2136	© 5322 122 32654	22nF	10%	63V	only for /17
2137	4822 124 40746	0,22μF	20%	63V	
2138	4822 124 41576	2,2μF	20%	50V	
2139	© 4822 126 14236	15pF	5%	50V	

2141	© 4822 126 10002	100nF	20%	50V	
2142	© 4822 126 10002	100nF	20%	50V	
2143	© 4822 126 13473	220nF	20%	50V	
2144	4822 124 40242	1μF	20%	63V	
2145	© 4822 122 33575	220pF	5%	50V	

2146	© 4822 122 33575	220pF	5%	50V	
2147	© 4822 122 33575	220pF	5%	50V	
2148	4822 126 11585	22nF	20%	50V	
2149	© 5322 122 32654	22nF	10%	63V	
2150	© 4822 122 31947	100nF	20%	50V	

2152	© 4822 126 12105	33nF	5%	63V	not for /14
2152	© 5322 116 80853	560pF	5%	63V	only for /14
2153	© 4822 122 32139	12pF	5%	63V	only for /14
2153	© 4822 122 32504	15pF	5%	50V	not for /14
2155	4822 125 60101	3-11pF		TRIMCAP.	

2159	© 5322 122 32659	33pF	5%	50V	
2160	© 5322 122 32654	22nF	10%	63V	
2164	© 4822 126 13482	470nF	20%	16V	
2165	© 4822 126 10002	100nF	20%	50V	
2166	© 5322 122 34123	1nF	10%	50V	

2167	© 4822 122 32139	12pF	5%	63V	
2168	© 4822 126 13695	82pF	1%	63V	

RESISTORS

3101	© 4822 051 20333	33kΩ	5%	0,1W	not for /14
3101	© 4822 051 20562	5,6kΩ	5%	0,1W	only for /14
3102	© 4822 051 20104	100kΩ	5%	0,1W	
3103	© 4822 117 10965	18kΩ	2%	0,1W	
3104	© 4822 117 11448	180Ω	10%	0,1W	

3105	4822 116 83872	220Ω	5%	0,5W	
3110	4822 116 52195	47Ω	5%	0,5W	
3120	© 4822 051 20008	CHIP JUMPER 0805			
3132	4822 116 52195	47Ω	5%	0,5W	
3134	© 4822 051 20224	220kΩ	5%	0,1W	

3141	© 4822 117 11148	56kΩ	1%	0,1W	
------	------------------	------	----	------	--

RESISTORS

3142	4822 100 11163	100kΩ		TRIMPOT LIN.	
3145	© 4822 117 11449	2,2kΩ	1%	0,1W	
3146	© 4822 051 20229	22Ω	5%	0,1W	
3152	4822 116 83883	470Ω	5%	0,16W	
3153	© 4822 051 20471	470Ω	5%	0,1W	

3154	4822 116 83868	150Ω	5%	0,5W	
3155	© 4822 051 20471	470Ω	5%	0,1W	
3156	© 4822 051 20104	100kΩ	5%	0,1W	not for /14/17
3157	4822 116 52234	100kΩ	5%	0,5W	only for /14
3158	4822 116 83883	470Ω	5%	0,16W	

3159	4822 116 83883	470Ω	5%	0,16W	
3160	4822 116 83883	470Ω	5%	0,16W	
3161	4822 116 83883	470Ω	5%	0,16W	
3167	© 4822 117 11503	220Ω	5%	0,1W	
3169	© 4822 051 20154	150kΩ	5%	0,1W	

3170	4822 116 52234	100kΩ	5%	0,5W	not for /14
3171	4822 116 52219	330Ω	5%	0,5W	
4101	© 4822 051 20008	CHIP JUMPER 0805			
4102	© 4822 051 20008	CHIP JUMPER 0805			
4103	© 4822 051 20008	CHIP JUMPER 0805			

4104	© 4822 051 20008	CHIP JUMPER 0805			
4105	© 4822 051 20008	CHIP JUMPER 0805			
4106	© 4822 051 20008	CHIP JUMPER 0805			
4108	© 4822 051 20008	CHIP JUMPER 0805			
4111	© 4822 051 20008	CHIP JUMPER 0805			

4120	© 4822 051 20008	CHIP JUMPER 0805			
4150	© 4822 051 10008	CHIP JUMPER 1206			
4152	© 4822 051 10008	CHIP JUMPER 1206			
4153	© 4822 051 10008	CHIP JUMPER 1206			
4154	© 4822 051 10008	CHIP JUMPER 1206			

4157	© 4822 051 10008	CHIP JUMPER 1206			
4158	© 4822 051 10008	CHIP JUMPER 1206			
4159	© 4822 051 10008	CHIP JUMPER 1206			

COILS

5102	4822 157 71634	RF-COIL MW			
5109	4822 242 70665	FM-IF FILTER 10,7MHZ			
5110	4822 242 70665	FM-IF FILTER 10,7MHZ			
5111	4822 158 60511	AM-IF FILTER 450kHz			
5112	4822 157 70302	AM-IF FILTER 450kHz			

5114	4822 157 70302	AM-IF FILTER 450kHz			
5119	4822 157 11443	DISCRIMINATOR COIL			
5121	4822 242 10261	QUARTZ 75kHz			
5123	4822 157 60517	RF-COIL AM			
5130	4822 156 30947	RF COIL 1,5 TURNS			

5131	4822 156 30947	RF COIL 1,5 TURNS			
------	----------------	-------------------	--	--	--

DIODES

6103	4822 130 30621	1N4148			
6104	4822 130 30621	1N4148			
6105	© 4822 130 83075	HN1V02H			
6106	4822 130 30621	1N4148			
6107	4822 130 34488	BZX79-C11			

6120	4822 130 30621	1N4148			only for /14/17
6130	© 4822 130 82833	1SV228			
6131	© 4822 130 82833	1SV228			

TRANSISTORS

7102	4822 130 60093	2SA838B			
7111	© 5322 130 42136	BC848C			

INTEGRATED CIRCUITS

7101	© 4822 209 90924	TEA575H/V1, RADIO IC			
------	------------------	----------------------	--	--	--

ELECTRICAL PARTS LIST *TUNER ECO5 for 06 (Japanese version)*

1102	4822 265 20598	SOCKET COAX YKD31-0468 75Ω
1130	4822 267 10749	CONNECTOR S11B-XH-A (11P)
2111	5322 122 32531	100pF 5%NPO 50V
2153	5322 122 33063	2.2pF 5% NPO 50V
3113	4822 051 10102	1kΩ 2% 0,25W
3119	4822 051 20331	330Ω 5% 0,1W
3134	4822 051 20223	22kΩ 5% 0,1W
3147	4822 111 50499	3.3MΩ 5% 0,2W
3155	4822 051 20101	100Ω 5% 0,1W
3175	4822 117 12955	2.7kΩ 1% 0,1W 0805
3177	4822 117 10833	10kΩ 1% 0,1W
3178	4822 051 20335	3.3MΩ 5% 0,1W
3179	4822 051 20105	1MΩ 5% 0,1W
4161	4822 051 20008	CHIP JUMPER. 0805
5113	4822 242 80989	FILTER SER. SFU450B 457kHz
5130	4822 157 70033	COIL-FM OSC
7101		TEA5759H/V1 RADIO IC
7119	4822 130 60163	2SC1047C
7125	5322 130 42755	BC847C BC848C

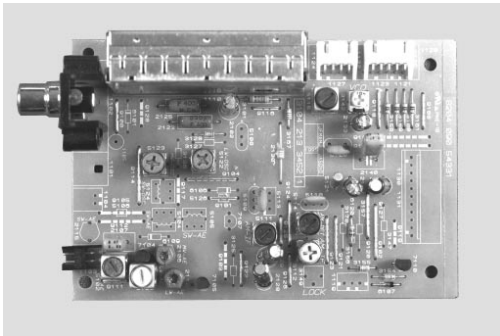

TUNER 95 BOARD

TABLE OF CONTENTS

Block diagram	7D 1
Adjustment table	7D 2
Component layout	7D 2
Circuit diagram	7D 3
Parts list	7D 4

BLOCKDIAGRAM

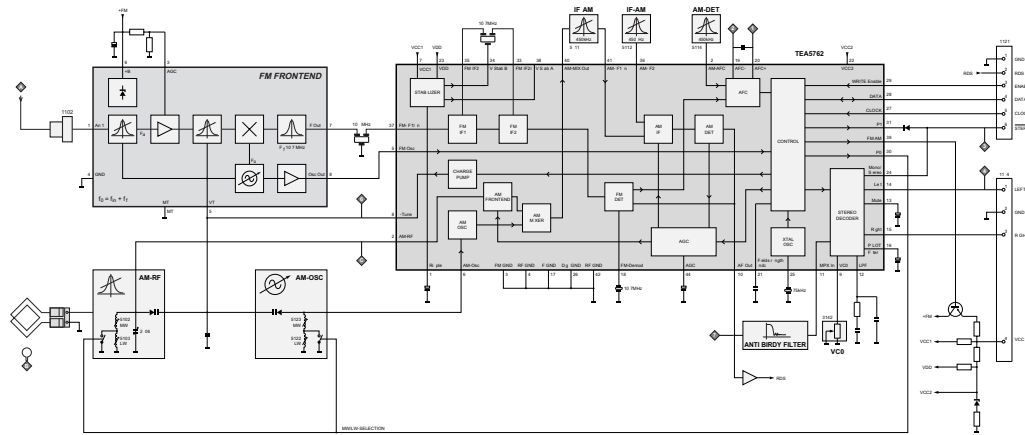



7D-4

7D-4

ELECTRICAL PARTS LIST - TUNER 95 BOARD

ELECTRICAL PARTS LIST - TUNER 95 BOARD

MISCELLANEOUS

1102	4822 267 10283	Socket Coaxial IEC 75R
1103	4822 265 31184	JST Connector 2 pin
1110	4822 210 10739	Frontend Assembly FE415-G23

CAPACITORS

2102	4822 124 40433	47µF 20% 25V
2106	4822 125 60102	Trimmer 5.2-30pF 100V
2107	4822 121 51252	470nF 5% 63V
2108	4822 126 13695	82pF 1% 63V
2109	4822 126 13691	27pF 1% 63V
2120	5322 122 32659	33pF 5% 50V
2122	5322 126 10465	3.9nF 10% 63V
2125	4822 121 10578	560P 1% 630V
2127	4822 122 32927	220nF +80/-20% 50V
2128	4822 124 41579	10µF 20% 50V
2129	4822 124 40242	1µF 20% 63V
2130	4822 126 11585	22nF +80/-20% 25V
2131	4822 122 33325	470nF 16V
2132	4822 122 33325	470nF 16V
2133	4822 124 40242	1µF 20% 63V
2134	4822 126 13188	15nF 5% 63V
2135	4822 122 32927	220nF +80/-20% 50V
2136	4822 126 13188	15nF 5% 63V
2137	4822 122 32927	220nF +80/-20% 50V
2138	4822 124 41576	2.2µF 20% 50V
2140	4822 121 51252	470nF 5% 63V
2141	4822 122 31947	100nF 20% 63V
2142	4822 122 31947	100nF 20% 63V
2143	4822 122 32927	220nF +80/-20% 50V
2144	4822 124 40242	1µF 20% 63V
2145	4822 122 33575	220pF 5% 50V
2147	4822 122 33575	220pF 5% 50V
2148	4822 122 33809	22nF 20% 50V
2150	4822 122 31947	100nF 20% 63V
2151	4822 126 14236	50V 15pF 5%
2152	4822 126 13695	82pF 1% 63V
2158	4822 122 31947	100nF 20% 63V
2160	4822 122 32139	12pF 2% 63V
2161	5322 122 34123	1nF 10% 50V
2162	4822 124 81151	22µF 50V

RESISTORS

3103	4822 051 20008	OR Jumper 0805
3104	4822 051 10102	1k 2% 0.25W
3107	4822 051 20829	82R 5% 0.1W
3108	4822 117 11449	2k2 1% 0.1W
3109	4822 117 11449	2k2 1% 0.1W
3123	4822 051 10008	OR 5% 0.25W
3124	4822 051 10008	OR 5% 0.25W
3125	4822 116 83864	10k 5% 0.5W
3128	4822 116 52256	2k2 5% 0.5W
3129	4822 051 20008	OR Jumper 0805

3130	4822 051 10008	OR 5% 0.25W
3131	4822 051 10008	OR 5% 0.25W
3132	4822 051 20008	OR Jumper 0805
3134	4822 051 20223	22k 5% 0.1W
3137	4822 117 10833	10k 1% 0.1W
3138	4822 051 20008	OR Jumper 0805
3139	4822 051 10008	OR 5% 0.25W
3140	4822 051 20331	330R 5% 0.1W
3141	4822 051 20563	56k 5% 0.1W
3142	4822 100 11163	Trimmer 100k 30% 0.1W
3143	4822 051 20223	22k 5% 0.1W
3144	4822 051 10102	1k 2% 0.25W
3145	4822 117 11449	2k2 1% 0.1W
3146	4822 051 20479	47R 5% 0.1W
3150	4822 051 20472	4k7 5% 0.1W
3151	4822 051 20683	68k 5% 0.1W
3152	4822 051 20471	470R 5% 0.1W
3153	4822 051 20471	470R 5% 0.1W
3154	4822 116 83872	220R 5% 0.5W
3155	4822 116 52219	330R 5% 0.5W
3158	4822 116 83883	470R 5% 0.5W
3159	4822 116 83883	470R 5% 0.5W
3160	4822 116 83883	470R 5% 0.5W
3161	4822 116 83883	470R 5% 0.5W
3162	4822 051 20224	220k 5% 0.1W
3163	4822 051 10008	OR 5% 0.25W
3164	4822 052 10478	Δ 4R7 5% 0.33W
3165	4822 051 10008	OR 5% 0.25W
3167	4822 116 83872	220R 5% 0.5W
3169	4822 051 20008	OR Jumper 0805
3171	4822 051 20008	OR Jumper 0805
3172	4822 051 10008	OR 5% 0.25W
3173	4822 051 20008	OR Jumper 0805
3176	4822 051 20008	OR Jumper 0805
3177	4822 051 20223	22k 5% 0.1W
3181	4822 051 10008	OR 5% 0.25W
3183	4822 051 10008	OR 5% 0.25W
3184	4822 051 10008	OR 5% 0.25W
3185	4822 051 10008	OR 5% 0.25W
3186	4822 051 10102	1k 2% 0.25W
3188	4822 051 10008	OR 5% 0.25W
3192	4822 051 20008	OR Jumper 0805
3197	4822 051 20472	4k7 5% 0.1W

COILS & FILTERS

5102	4822 157 71634	MW AERIAL
5103	4822 157 71635	LW AERIAL
5107	4822 157 11443	FM Discriminator 10.7MHz
5109	4822 157 71639	Ceram Filter 10.7MHz
5110	4822 242 70665	Ceram Filter 10.7MHz
5111	4822 158 60511	AM-IF Filter 450kHz
5112	4822 157 70302	AM-IF Filter 450kHz

5114	4822 157 70302	AM-IF Filter 450kHz
5115	4822 157 71636	Anti-Birdy Filter
5121	4822 242 10261	X'tal Resonator 75kHz
5122	4822 157 60517	RF Coil AM
5123	4822 157 60517	RF Coil AM

DIODES

6105	4822 130 83075	HN1V02H-B
6107	4822 130 34488	BZX79-B11
6120	4822 130 30621	1N4148

TRANSISTORS & INTEGRATED CIRCUITS

7101	4822 209 90315	TEA5762H/V1
7103	4822 130 42513	BC858C
7104	5322 130 44779	BC338-40
7105	5322 130 44779	BC338-40
7109	5322 130 41983	BC858B
7110	5322 130 41983	BC858B
7122	5322 130 42136	BC848C
7124	5322 130 42136	BC848C

Note: Only the parts mentioned in this list are normal spare parts.

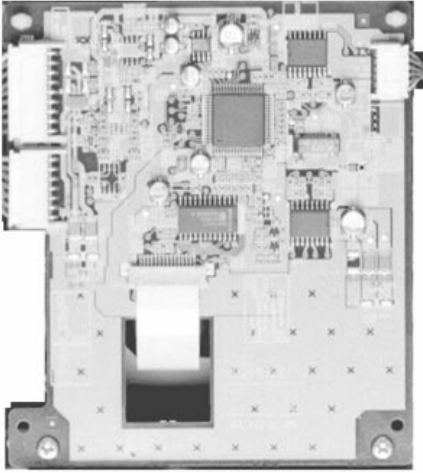

CD BOARD NAMI 8

TABLE OF CONTENTS

- Block diagram 8-1
- Component layout 8-2
- Circuit diagram 8-3
- Parts list 8-4

BLOCK DIAGRAM

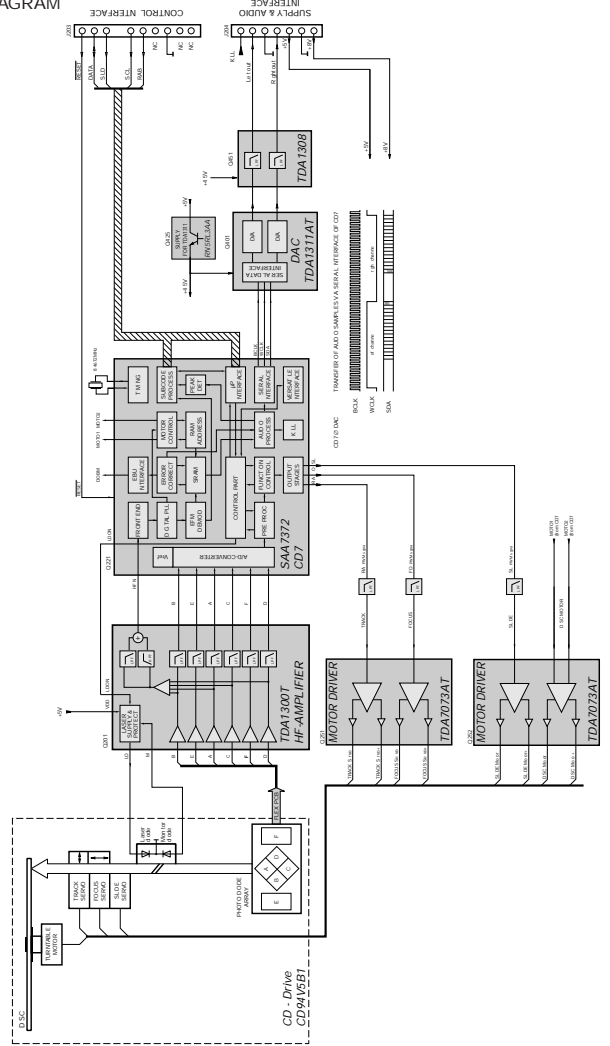

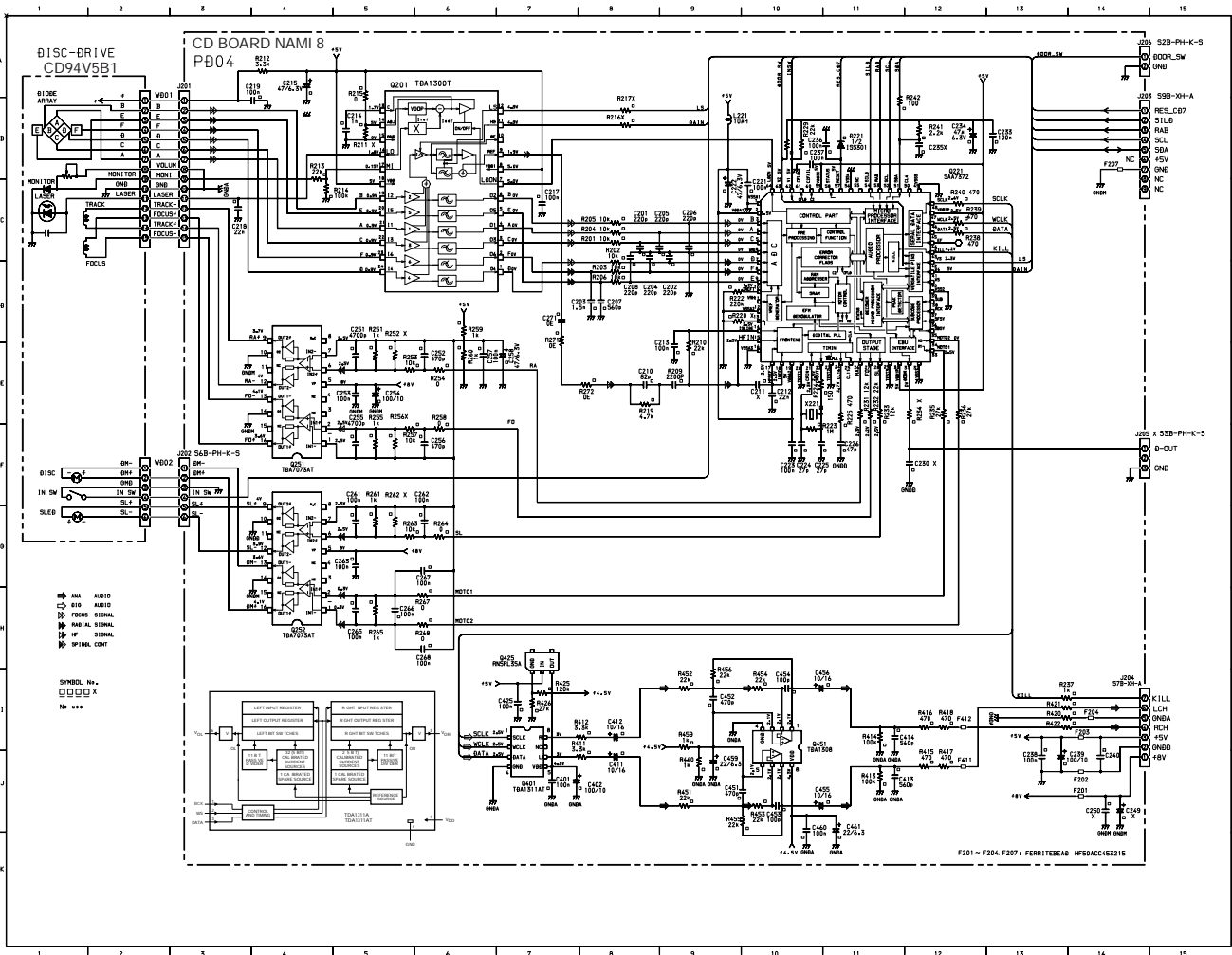

C201 C8	J201 B3	R418 I12
C202 C9	J202 F3	R420 I13
C203 D8	J203 B14	R421 I13
C204 C8	J204 I14	R422 I13
C205 C9	J205 F14	R425 I7
C206 C9	J206 A14	R426 I7
C207 D8	L221 B9	R451 J9
C208 C8		R452 J9
C210 E8	C201 C5	R453 J10
C211 E10	C221 D11	R454 I10
C212 E10	O251 E4	R455 J10
C213 E9	O252 G4	R456 J9
C214 B5	O401 J7	R459 J9
C215 A4	C425 H7	R460 J9
C217 C7	C451 H10	
C218 C3		X221 E10
C219 A4	R201 C8	
C222 C9	R202 D8	
C223 F10	R203 D8	
C224 F10	R204 C8	
C225 F10	R205 C8	
C226 F11	R206 D8	
C230 F12	R209 E9	
C233 B13	R210 E9	
C234 B12	R211 B5	
C235 B12	R212 A4	
C236 B11	R213 B4	
C237 B10	R214 C4	
C238 J13	R215 A5	
C239 J13	R216 B8	
C240 J14	R217 B8	
C245 I7	R219 E8	
C249 J14	R220 D9	
C250 J14	R222 D9	
C251 E5	R223 F10	
C252 E5	R224 E10	
C253 E5	R225 E11	
C254 E5	R229 B10	
C255 F5	R231 E11	
C256 F6	R232 E11	
C257 E6	R233 E11	
C258 E7	R234 E12	
C261 G5	R235 E12	
C262 G6	R236 E12	
C263 G5	R238 C12	
C265 H5	R239 C12	
C266 H5	R240 C12	
C267 G6	R241 B12	
C268 H6	R242 B11	
C271 D7	R251 E5	
C401 J7	R252 E5	
C402 J7	R253 E5	
C411 J8	R254 E6	
C412 B8	R255 F5	
C413 J11	R256 F5	
C414 I11	R257 F5	
C451 J10	R258 F6	
C452 J9	R259 D6	
C453 J10	R260 E6	
C454 I10	R261 G5	
C455 J10	R262 G5	
C456 I10	R263 G5	
C459 J9	R264 G6	
C460 J10	R265 H5	
C461 J11	R267 H6	
C462 H6	R268 H6	
D221 B11	R271 D7	
F201 J14	R411 J8	
F202 J14	R412 B8	
F203 I14	R413 J11	
F204 I14	R414 I11	
F207 B14	R415 J12	
F411 J12	R416 I12	
F412 I12	R417 J12	

(VERS.:VERSION, U:U.S.A., F:JAPAN, K:FAR EAST, --:EUROPE)

POS. NO	VERS. COLOR	PART NO. (FOR PCS)	DESCRIPTION	PART NO. (MUJ)
			PD04-CD SERVO DECODER DAC CIRCUIT BOARD	
			PD04-CAPACITORS	
C201	4822 126 13883	CER. CHIP 220pF ±5% CG 50V	DD95221300	R201
C202	4822 126 13883	CER. CHIP 220pF ±5% CG 50V	DD95221300	R206
C203	4822 126 12495	CER. CHIP 1500pF ±10%	DK96152300	R209
C204	4822 126 13883	CER. CHIP 220pF ±5% CG 50V	DD95221300	R210
C205	4822 126 13883	CER. CHIP 220pF ±5% CG 50V	DD95221300	R212
C206	4822 126 13883	CER. CHIP 220pF ±5% CG 50V	DD95221300	R213
C207	4822 126 14249	CER. CHIP 560pF ±10%	DK96561300	R214
C208	4822 126 13883	CER. CHIP 220pF ±5% CG 50V	DD95221300	R215
C210	4822 122 33788	CER. CHIP 82pF ±5%	DD95820300	R219
C212	4822 126 11567	CER. CHIP 0.022µF ±10% XTR	DK96223200	R222
C213	4822 126 11687	CER. CHIP 0.1µF ±80%-20%	DK98104200	R223
C214	4822 126 12516	CER. CHIP 1000pF ±10% B 50V	DK96102300	R224
C215	4822 124 11131	ELECT CHIP 47µF 6.3V	EY47600620	R225
C217	4822 126 11687	CER. CHIP 0.1µF ±80%-20%	DK98104200	R229
C218	4822 126 11567	CER. CHIP 0.022µF ±10 % XTR	DK96223200	R231
C219	4822 126 11687	CER. CHIP 0.1µF ±80%-20%	DK98104200	R232
C221	4822 126 11687	CER. CHIP 0.1µF ±80%-20%	DK98104200	R233
C222	4822 124 11131	ELECT CHIP 47µF 6.3V	EY47600620	R235
C223	4822 126 11687	CER. CHIP 0.1µF ±80%-20%	DK98104200	R236
C224	4822 126 11669	CER. CHIP 27pF ±5%	DD95270300	R238
C225	4822 126 11669	CER. CHIP 27pF ±5%	DD95270300	R239
C226	4822 122 33777	CER. CHIP 47pF ±5% C6 50V	DD95470300	R240
C233	4822 126 11687	CER. CHIP 0.1µF ±80%-20%	DK98104200	R241
C234	4822 124 11131	ELECT CHIP 47µF 6.3V	EY47600620	R242
C236	4822 126 11687	CER. CHIP 0.1µF ±80%-20%	DK98104200	R251
C237	4822 126 11687	CER. CHIP 0.1µF ±80%-20%	DK98104200	R253
C238	4822 126 11687	CER. CHIP 0.1µF ±80%-20%	DK98104200	R254
C239	4822 124 11432	ELECT CHIP 100µF 10V	EY10701020	R255
C251	4822 126 11685	CER. CHIP 4700pF ±10%	DK96472300	R257
C252	4822 126 11568	CER. CHIP 470pF ±10%	DK96471300	R258
C253	4822 126 11687	CER. CHIP 0.1µF ±80%-20%	DK98104200	R259
C254	4822 124 11432	ELECT CHIP 100µF 10V	EY10701020	R260
C255	4822 126 11685	CER. CHIP 4700pF ±10%	DK96472300	R261
C256	4822 126 11568	CER. CHIP 470pF ±10%	DK96471300	R262
C257	4822 126 11687	CER. CHIP 0.1µF ±80%-20%	DK98104200	R264
C258	4822 124 11131	ELECT CHIP 47µF 6.3V	EY47600620	R265
C261	4822 126 11687	CER. CHIP 0.1µF ±80%-20%	DK98104200	R267
C262	4822 126 11687	CER. CHIP 0.1µF ±80%-20%	DK98104200	R268
C263	4822 126 11687	CER. CHIP 0.1µF ±80%-20%	DK98104200	R271
C265	4822 126 11687	CER. CHIP 0.1µF ±80%-20%	DK98104200	R272
C268	4822 126 11687	CER. CHIP 0.1µF ±80%-20%	DK98104200	R411
C271	4822 116 82487	CHIP 0Ω ±5% 1/16W	NN05000610	R412
C401	4822 126 11687	CER. CHIP 0.1µF ±80%-20%	DK98104200	R413
C402	4822 124 11432	ELECT CHIP 100µF 10V	EY10701020	R414
C411	4822 124 11074	ELECT CHIP 10µF 16V	EY10601620	R415
C412	4822 124 11074	ELECT CHIP 10µF 16V	EY10601620	R419
C413	4822 126 14249	CER. CHIP 560pF ±10%	DK96561300	R420
C414	4822 126 11687	CER. CHIP 0.1µF ±80%-20%	DK98104200	R421
C425	4822 126 11568	CER. CHIP 470pF ±10%	DK96471300	R422
C452	4822 126 11568	CER. CHIP 470pF ±10%	DK96471300	R423
C453	4822 126 11759	CER. CHIP 100pF ±5%	DD95101300	R424
C454	4822 126 11759	CER. CHIP 100pF ±5%	DD95101300	R425
C455	4822 124 11074	ELECT CHIP 10µF 16V	EY10601620	R426
C456	4822 124 11074	ELECT CHIP 10µF 16V	EY10601620	R451
C459	4822 124 11226	ELECT CHIP 22µF 6.3V	EY22600620	R456
C460	4822 126 11687	CER. CHIP 0.1µF ±80%-20%	DK98104200	R459
C461	4822 124 11226	ELECT CHIP 22µF 6.3V	EY22600620	R460

(VERS.:VERSION, U:U.S.A., F:JAPAN, K:FAR EAST, --:EUROPE)

POS. NO	VERS. COLOR	PART NO. (FOR PCS)	DESCRIPTION	PART NO. (MUJ)
			PD04-RESISTORS	
D221		4822 130 83715	CHIP 10kΩ ±5% 1/16W	NN05103610
Q201		4822 209 16855	IC TDA1300T HF AMP AND LASER CONT	HC10172490
Q221		4822 209 91174	IC SAA737ZGP SERVO	HC10132490
Q251		4822 209 16372	IC TDA7073AT	HC10165490
Q252		4822 209 16372	DUAL BTL DRIVER	HC10165490
Q401		4822 209 32196	IC TDA1311AT CC-DAC	HC10173490
Q425		4822 209 15595	IC RNSRL35AA	HC10021770
Q451		4822 209 33165	V-REGULATOR 3.5V	HC10138490
			PD04-MISCELLANEOUS	
F201		4822 157 10313	HF50ACC453215	FN31020010
F207		4822 157 53872	CHIP INDUCTANCE	LU12103010
L221		4822 157 53872	NL322522-100K	
WD01		4822 320 12646	JUMPER LEAD FCC	YU15073500
X221		4822 242 11017	CRYSTAL CM309S 8.4672MHZ	JX08001320
			FERRITE BEADS	
			BK1608HM102-T	FC90020120
			FERRITE BEADS	
			BK1608HM102-T	FC90020120
		4822 116 82487	CHIP 0Ω ±5% 1/16W	NN05000610
		4822 116 82487	CHIP 0Ω ±5% 1/16W	NN05000610
		4822 116 82487	CHIP 0Ω ±5% 1/16W	NN05000610
		4822 117 11374	CHIP 120kΩ ±1% 1/10W	NO1124110
		4822 117 12024	CHIP 27kΩ ±1% 1/10W	NO1273110
		4822 051 30223	CHIP 22kΩ ±5% 1/16W	NN05223610
		4822 051 30102	CHIP 1kΩ ±5% 1/16W	NN05102610
		4822 051 30102	CHIP 1kΩ ±5% 1/16W	NN05102610

9. EXPLODED VIEW AND PARTS LIST

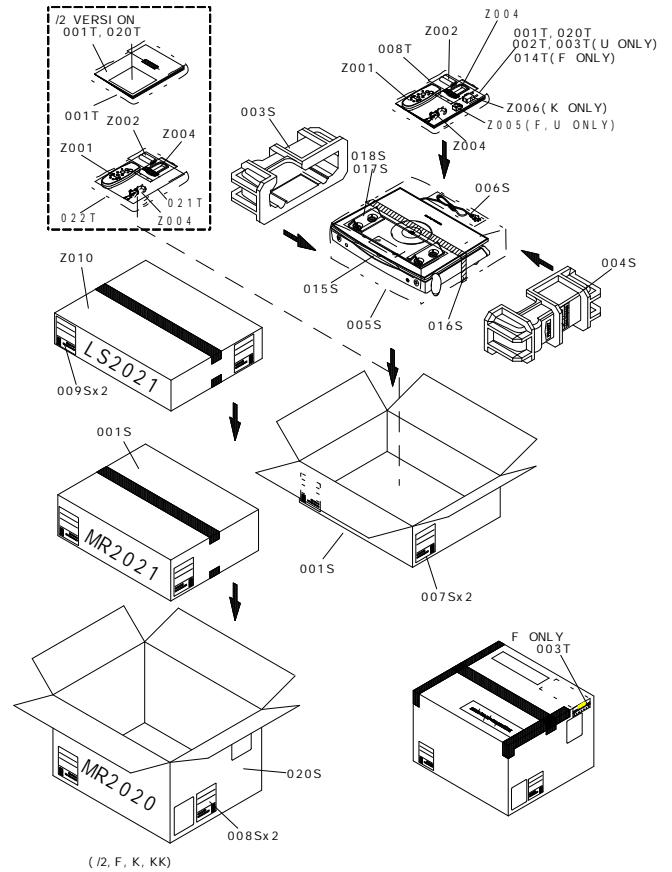

(VERS.:VERSION, U:U.S.A., F:JAPAN, K:FAR EAST, **:EUROPE)

POS. NO	VERS. COLOR	PART NO. (FOR PCS)	DESCRIPTION	PART NO. (MJI)	POS. NO	VERS. COLOR	PART NO. (FOR PCS)	DESCRIPTION	PART NO. (MJI)		
001T	F	4822 736 16729	PACKING	298J851110	001S	F,U	4822 303 30314	NOT STANDARD SPARE PARTS	298J801010		
001T	K		USER GUIDE		298J851350	003S		F,U		CUSHION L	298J809010
001T	KK		USER GUIDE		298J851360	004S		F,U		CUSHION R	298J809020
001T	/2		USER GUIDE		298J851310	020S		F		MASTER CARTON CASE MR2020	298J801030
001T	U		USER GUIDE		298J851250	010T				CLAMPER ASSY	298J005500
Z001			REMOTE COMMANDER RC2020MR	ZK298J0010	014T	F		145J865210			
					020T	F		298J861110			
					020T	/2,K, KK,U		298J861120			
					021T	/2		298J107040			
					055T			298J493A00			
					Z001			ZK298J0010			
					Z002	F		ZF24302000			
					Z003			LA00055020			
					Z004	F	4822 303 30314	ZA02000070			
					Z004	/2,K, KK		ZA02800020			
					Z004	U	4822 303 30314	ZA02000070			
					Z005	F,U	4822 264 30265	YP90000310			
					Z006	K	4822 265 10092	YJ04001240			
					Z007	F,K,KK		AS20100180			
					Z007	U		AS20100190			
					Z008			354H251230			
					Z010	F,		298J801020			

(VERS.:VERSION, U:U.S.A., F:JAPAN, K:FAR EAST, **:EUROPE)

POS. NO	VERS. COLOR	PART NO. (FOR PCS)	DESCRIPTION	PART NO. (MJI)	POS. NO	VERS. COLOR	PART NO. (FOR PCS)	DESCRIPTION	PART NO. (MJI)
001B	F,K,KK, U		FRONT PANEL ASSY	298J248510	901G	U		REAR PANEL	298J250030
001B	/2	4822 466 12193	FRONT PANEL ASSY	298J248500	917G		4822 532 60948	BUSHING AC MAINS	450H259010
002B	F,K,KK, U		FRONT PANEL	298J248020	001M		4822 522 10753	MECHANISM GEAR ASSY	298J304510
002B	/2		FRONT PANEL	298J248010	002M		4822 361 30368	D.C MOTOR	MM00460020
003B		4822 45010615	WINDOW FL	298J158040	011M		4822 522 10754	GEAR A	298J058100
005B			LENS SENSOR	298J355020	013M		4822 522 10755	GEAR B	298J058110
009B			LENS DSC SENS	298J355030	015M		4822 522 10756	GEAR C	298J058120
011B		4822 410 12282	BUTTON TOP	298J270010	017M		4822 522 10757	GEAR D	298J058130
018B		4822 532 11388	T.L. WASHER FOR W802	54050300R0	019M			PULLEY	298J262100
023B			SCREW FOR CD MECHA	183J010010	021M			SHAFT A	298J112100
031B		4822 404 10992	SUSTAINER L	298J106020	023M			SHAFT B	298J112110
032B		4822 404 10991	SUSTAINER R	298J106030	027M		4822 358 10273	BELT	298J264100
033B			P.H.M. SCREW FOR SUSTAINER+PANEL	51250308U0	041M		4822 691 10781	MECHANISM CD MECHA ASSY	298J304500
034B		4822 520 10859	SUSTAINER BEARING	298J106060	045M		4822 529 10428	DAMPER SUSPENSION RUBBER A	298J130010
037B		4822 528 11315	CAM L	298J054010	047M		4822 529 10429	DAMPER SUSPENSION RUBBER B	298J130020
039B		4822 528 11316	CAM R	298J054020	049M			COVER CD MECHA	298J053010
041B		4822 502 13315	B.T.SCREW W/TL FOR CUM+PANEL	51290308M0	FH01	/2		FERRITE CORE	FC50200020
043B			P.H. B TITE 1 SCREW FOR CUM+SENSOR	51900208U0	▲ L001	F		ZCAT1325-0530A CLAMP	
049B			WASHER FOR CD MECHA REAR	298J012010	▲ L001	K		MAINS TRANSF. AC100V	TS17206010
052B			COVER FOR GEAR ASSY	298J053020	▲ L001	KK		MAINS TRANSF. AC110-220V	TS17206040
055B			BUFFER FOR CD	298J056070	▲ L001	/2	4822 146 11124	MAINS TRANSF. AC220V	TS17206050
001D	F,K,KK, U	WINDOWF		298J158030	▲ L001	U		MAINS TRANSF. AC230V	TS17206030
001D	/2	4822 466 10616	WINDOW N	298J158010	M001		4822 361 11159	MAINS TRANSF. AC120V	TS17206020
003D		4822 466 12194	LID	298J257010	M705			D.C MOTOR BRUSHLESS FAN KD1204PFB2-8	MM01200290
004D			BUFFER FOR LID	298J056020	SS21		4822 271 30768	LEAF SPRING	298J116010
005D		4822 402 11277	LEVER ASSY	298J354500	SS22		4822 271 30768	MINI SW. DOOR CLOSE	SM01011530
010D			STICKER ADHESIVE FOR 011D	298J122010	WU03		4822 320 12647	MINI SW. DOOR OPEN	SM01011530
011D		4822 462 11164	CAP FOR WINDOW	298J067030	WU04		4822 320 12648	JUMPER LEAD 8P FFC	YU08238500
012D		4822 402 11278	BRACKET ROLLER ASSY L	298J160520				JS02-JS11	
013D		4822 402 11279	BRACKET ROLLER ASSY R	298J160530	▲ W001	F	4822 321 11359	JUMPER LEAD 13P FFC	YU13268500
015D			ROLLER LID	298J358010	▲ W001	K,U		JU10-JS01	
016D			ROLLER LID	298J358010	▲ W001	KK		A.C MAINS CORD	YC01800800
019D		4822 530 70122	RG RING E RING	64000200R0	▲ W001	/2	4822 321 11343	A.C MAINS CORD AC250V 10A	YC01800880
020D		4822 530 70122	RG RING E RING	64000200R0				A.C MAINS CORD 3A 250V	YC02000820
041D			P.H.M. SCREW FOR RETAINER	51250305U0				A.C MAINS CORD	YC01800790
047D		4822 522 10751	GEAR FOR LID	298J058020					
049D		4822 502 13315	B.T.SCREW W/TL FOR GEAR+LID	51290308M0					
053D			P.H.M. SCREW FOR LID	51250305U0					
067D			BUFFER FOR SHIELD	345S056030					
001G		4822 442 01753	CASE BOTTOM	298J064010					
003G		4822 381 12069	LENS IR	298J355010					
005G		4822 410 12283	BUTTON FRONT STANDBY	298J270020					
007G		4822 410 12282	BUTTON FRONT OPEN/CLOSE	298J270030					
021G		4822 462 11165	LEG FRONT	298J057010					
023G		4822 502 13315	B.T.SCREW W/TL FOR LEG FRONT+BOTTOM CASE	51290308M0					
025G		4822 462 11166	LEG REAR	298J057020					
026G		4822 462 11167	LEG FOR FRONT	298J057050					
027G		4822 462 11168	LEG FOR REAR	298J057030					
028G		4822 535 10629	PIN FOR FRONT LEG	298J254020					
029G		4822 535 10631	PIN FOR REAR LEG	298J254010					
030G			LEG SUB	298J057040					
037G		4822 522 10752	GEAR E	298J058010					
049G		4822 442 01754	LID BOTTOM	298J257020					
901G	F		REAR PANEL	298J250020					
901G	K		REAR PANEL	298J250040					
901G	KK		REAR PANEL	298J250050					
901G	/2		REAR PANEL	298J250010					

10. ELECTRICAL PARTS LIST

ASSIGNMENT OF COMMON PARTS CODES.

RESISTORS

R***: 1) GD05 x x x 140, Carbon film fixed resistor, ±5% 1/4W

R***: 2) GD05 x x x 160, Carbon film fixed resistor, ±5% 1/6W

① Resistance value

Examples: ① Resistance value

0.1 Ω ... 0.01 10 Ω ... 100 1 kΩ ... 102 100 kΩ ... 104

0.5 Ω ... 0.05 18 Ω ... 180 2.7 kΩ ... 272 680 kΩ ... 684

1 Ω ... 0.10 100 Ω ... 101 10 kΩ ... 103 1 MΩ ... 105

6.8 Ω ... 0.68 390 Ω ... 391 22 kΩ ... 223 4.7 MΩ ... 475

Note: Please distinguish 1/4W from 1/6W by the shape of parts used actually.

CAPACITORS

C***: CERAMIC CAP

3) DD1 x x x 370, Ceramic capacitor

Disc type Temp.coeff.P350 ~N1000, 50V

② Capacity value

Examples: ② Tolerance (Capacity deviation)

±0.25 PF ... 0

±0.5 PF ... 1

±5% ... 5

* Tolerance of COMMON PARTS handled here are as follows:

0.5 pF ~ 5 pF ... ±0.25 pF

6 pF ~ 10 pF ... ±0.5 pF

12 pF ~ 560 pF ... ±5%

③ Capacity value

0.5 pF ... 0.05 3 pF ... 0.30 100 pF ... 101

1 pF ... 0.10 10 pF ... 100 220 pF ... 221

1.5 pF ... 0.15 47 pF ... 470 560 pF ... 561

C***: CERAMIC CAP

4) DK16 x x x 300, High dielectric constant ceramic capacitor

Disc type Temp.chara. 2B4, 50V

④ Capacity value

Examples: ④ Capacity value

100 pF ... 0.1 1000 pF ... 102 10000 pF ... 103

470 pF ... 471 2200 pF ... 222

C***: 5) ELECTROLY CAP (E), 6) FILM CAP (F)

5) EA x x x x x x 10, Electrolytic capacitor

One-way lead type, Tolerance ±20%

⑤ Working voltage

Examples: ⑤ Capacity value

0.1 μF ... 104 4.7 μF ... 475 100 μF ... 107

0.33 μF ... 334 10 μF ... 106 330 μF ... 337

1 μF ... 105 22 μF ... 226 1100 μF ... 118

2200 μF ... 228

⑥ Working voltage

6.3V ... 006 25V ... 025

10V ... 010 35V ... 035

16V ... 016 50V ... 050

6) DF15 x x x 350, Plastic film capacitor

DF15 x x x 310, One-way type, Mylar ±5% 50V

DF16 x x x 310, Plastic film capacitor

One-way type, Mylar ±10% 50V

⑦ Capacity value

Examples: ⑦ Capacity value

0.001 μF (1000 pF) ... 102 0.1 μF ... 104

0.0018 μF ... 182 0.56 μF ... 564

0.01 μF ... 103 1 μF ... 105

0.015 μF ... 153

NOTE: 1) The above CODES (R***, R***, C***, C*** and C***) are omitted on the schematic diagram in some case.

2) On the occasion, be confirmed the common parts on the parts list.

3) Refer to "Common Parts List" for the other common parts (R05, DD4, DK4).

NOTE ON SAFETY FOR FUSIBLE RESISTOR:

The suppliers and their type numbers of fusible resistors are as follows:

1. KOA Corporation

Part No. (MUJ) Type No. (KOA) Description

NH05 x x x 140 RF25S x x x x ΩJ (±5% 1/4W)

NH05 x x x 120 RF50S x x x x ΩJ (±5% 1/2W)

NH85 x x x 110 RF73B2A x x x x ΩJ (±5% 1/10W)

NH95 x x x 140 RF73B2E x x x x ΩJ (±5% 1/4W)

* Resistance value Resistance value (0.1 Ω - 10 kΩ)

2. Matsushita Electronic Components Co., Ltd

Part No. (MUJ) Type No. (MEC) Description

NF05 x x x 140 ERD-2FCJ x x x x (±5% 1/4W)

RF05 x x x 140 ERD-2FCG x x x x (±2% 1/4W)

RF02 x x x 140

* Resistance value * Resistance value

Examples: * Resistance value

0.1 Ω ... 0.01 10 Ω ... 100 1 kΩ ... 102 100 kΩ ... 104

0.5 Ω ... 0.05 18 Ω ... 180 2.7 kΩ ... 272 680 kΩ ... 684

1 Ω ... 0.10 100 Ω ... 101 10 kΩ ... 103 1 MΩ ... 105

6.8 Ω ... 0.68 390 Ω ... 391 22 kΩ ... 223 4.7 MΩ ... 475

ABBREVIATION AND MARKS

Table with 4 columns: ANT, CAP, CONN, HP, μ PRO, RES, SW, TRIM, VAR and their corresponding descriptions like ANTENNA, CAPACITOR, CONNECTING, HEADPHONE, MICROPROCESSOR, RESISTOR, SWITCH, TRIMMING, VARIABLE.

NOTE ON SAFETY:

Symbol ⚠ Fire or electrical shock hazard. Only original parts should be used to replaced any part marked with symbol ⚠.

Any other component substitution (other than original type), may increase risk of fire or electrical shock hazard.

(VERS.:VERSION, U:U.S.A., F:JAPAN, K:FAR EAST, --:EUROPE)

Main parts list table with columns: POS. NO., VERS. COLOR, PART NO. (FOR PCS), DESCRIPTION, PART NO. (MUJ), POS. NO., VERS. COLOR, PART NO. (FOR PCS), DESCRIPTION, PART NO. (MUJ). Contains various electronic components like resistors, capacitors, diodes, and fuses.

(VERS. :VERSION, U:U.S.A., F:JAPAN, K:FAR EAST, **:EUROPE)

POS. NO	VERS. COLOR	PART NO. (FOR PCS)	DESCRIPTION	PART NO. (MJI)	POS. NO	VERS. COLOR	PART NO. (FOR PCS)	DESCRIPTION	PART NO. (MJI)
CA02	F	4822 124 21894	PA04-AM-STEREO CIRCUIT BOARD [F Version]	EJ10601610	SS01		4822 276 14088	PS04-SW ASSY CIRCUIT BOARD	SP01013280
CA03	F	4822 124 21894	PA04-CAPACITORS	EJ10601610	SS02		4822 276 14088	TACT SW. ALPS-SKQUAA	SP01013280
CA04	F	4822 122 30043	ELECT 10μF 16V	DK18103310				PS14-SW ASSY CIRCUIT BOARD	
CA05	F	4822 122 30043	CER. 0.01μF +80%-20% 50V	DK18103310	SS11		4822 276 14088	TACT SW.ALPS-SKQUAA	SP01013280
CA11	F	4822 124 21894	ELECT 10μF 16V	EJ10601610	SS12		4822 276 14088	TACT SW.ALPS-SKQUAA	SP01013280
CA13	F	4822 124 23053	ELECT 1μF 50V	EJ10505010				PS54-IR ASSY C IRCUIT BOARD	
CA14	F	4822 122 30043	CER. 0.01μF +80%-20% 50V	DK18103310	CS51		4822 126 10935	ELECT 100μF 6.3V	EJ10700610
CA15	F	4822 122 31205	CER. 47pF ±5% CH 50V BLK	DD15470300	QS51		4822 130 11494	PHOTO UNIT RPM6936-V4	HW10004210
CA16	F	4822 124 23056	ELECT 47μF 16V	EJ47601610				IR SENSOR	
CA20	F	4822 124 23056	ELECT 47μF 16V	EJ47601610	SS51		4822 276 20508	PUSH SW. EVQ11L05R	SP01013370
CA21	F	4822 122 30043	CER. 0.01μF +80%-20% 50V	DK18103310				PS64-DOOR SW ASSY CIRCUIT BOARD	
CA22	F	4822 124 40786	ELECT 2.2μF 50V	EJ22505010				PUSH SW. EVQ11L05R	SP01013370
CA23	F	4822 124 40786	ELECT 2.2μF 50V	EJ22505010				PU04-μ-COM ASSY CIRCUIT BOARD	
CA24	F	4822 124 23053	ELECT 1μF 50V	EJ10505010				PU04-CAPACITORS	
			PA04 CAPACITORS (COMMON) HIGH DIELECTRIC CONSTANT CER. CAPACITOR ±10% 50V : CA01 CA17-CA19		CF22		4822 126 11558	CER. 0.1μF +80%-20% 50V	DA17104110
			PLASTIC FILM CAPACITOR ±5% 50V : CA06-CA10 CA12		CF49	/2	4822 126 10408	CER. 220pF ±10% B 50V	DA16221110
			PA04-RESISTOR Ω G 1/4W	NF02820140	CF50	/2	4822 126 10408	CER. 220pF ±10% B 50V	DA16221110
▲ RA08	F	FUSE82			CF51	/2		CER. 1500pF ±20% X 50V	DA17152110
			PA04-RESISTORS (COMMON) CARBON FILM FIXED RES. ±5% 1/6W : RA01-RA07		CF53		4822 124 21894	ELECT 10μF 16V	EJ10601610
			PA04-SEMICONDUCTORS		CF54		4822 124 21894	ELECT 10μF 16V	EJ10601610
DA01	F	4822 130 32362	DIODE 1SS176 MA165 1SS254 30V 0.1A	HD20002000	CF55		4822 126 10362	CER. 22pF ±5% SL 50V	DA15220110
DA02	F	4822 130 32362	DIODE 1SS176 MA165 1SS254 30V 0.1A	HD20002000	CF56		4822 126 10362	CER. 22pF ±5% SL 50V	DA15220110
DA03	F	4822 130 32362	DIODE 1SS176 MA165 1SS254 30V 0.1A	HD20002000	CF57		4822 124 21894	ELECT 10μF 16V	EJ10601610
QA01	F		IC MC13022P AM STEREO	HC10078170	CF58		4822 124 21894	ELECT 10μF 16V	EJ10601610
QA02	F		IC 74HC4053 C-MOS	HC705300B0	CF59		4822 124 23056	ELECT 47μF 16V	EJ47601610
QA03	F	4822 130 41947	TRS. 2SC2458 2SC1740S 2SC3199 ETC.	HT30001000	CF60		4822 122 40586	CER. 0.01μF ±20% Y 50V	DA17103110
QA04	F	4822 130 42715	TRS. 2SA1048 2SA933S 2SA1267 ETC.	HT10001000	CF61		4822 122 40586	CER. 0.01μF ±20% Y 50V	DA17103110
LA01	F		PB04-MISCELLANEOUS I.F.T. COIL A7NRES-T1370Y 450kHz	LI71010120	CU01		4822 126 10513	CER. 47pF ±5% SL 50V	DA15470110
XA01	F		SERAMVIB. CSA3.6MGF103	FQ03604020	CU02		4822 126 10513	CER. 47pF ±5% SL 50V	DA15470110
CH15		4822 126 12496	PH04-HEAD PHONE JACK CIRCUIT BOARD	DD38103010	CU03		4822 126 10513	CER. 47pF ±5% SL 50V	DA15470110
CH16		4822 126 12496	PH04-CAPACITORS	DD38103010	CU04		4822 126 10364	CER. 100pF ±10% B 50V	DA15470110
CH17		4822 122 40617	CER. 0.01μF +80%-20% 50V	DD38103010	CU05	/2	4822 126 10513	CER. 47pF ±5% SL 50V	DA15470110
			CER. 0.01μF +80%-20% 50V	DD38103010	CU08	/2	4822 122 31237	CER. 82pF ±5% CH 50V	DD15820300
			CER. 0.1μF +80%-20% 50V	DD38104010	CU09	/2	4822 122 31205	CER. 47pF ±5% CH 50V	DD15470300
JH01		4822 242 11018	PB04-MISCELLANEOUS JACK HEAD PHONE	YJ01004500	CU10	/2	4822 126 12496	CER. 0.01μF DC50V +80 -20%	DD38103010
LH10			HS10914-01-040		CU11	/2	4822 122 40617	CER. 0.1μF DC50V +80 -20%	DD38104010
LH11			JUMPER	75060501P0	CU12	/2	4822 126 11071	CER. 330pF ±10% B 50V	DA16331110
LH14					CU13	/2	4822 124 40786	ELECT 2.2μF 50V	EJ22505010
					CU14	/2	4822 126 10409	CER. 560pF ±10% B 50V	DA16561110
					CU17		4822 124 23295	BIG ELECT 0.022μF 5V	EX22300510
					CU18		4822 126 10935	ELECT 100μF 6.3V	EJ10700610
					CU19		4822 122 40586	CER. 0.01μF ±20% 50V	DA17103110
					CU20		4822 126 10935	ELECT 100μF 6.3V	EJ10700610
					CU21		4822 126 12867	ELECT. 1000μF 6.3V	OA108006Q0
					CU24		4822 122 40589	CER. 0.047μF ±10% F 50V	DA17473110
					CU27		4822 122 31823	CER. 15pF ±5% CH 50V	DD15150300
					CU28		4822 122 31823	CER. 15pF ±5% CH 50V	DD15150300
					CU29		4822 122 40617	CER. 0.1μF +80%-20% 50V	DD38104010
					CU30		4822 124 23053	ELECT 1μF 50V	EJ10505010
					CU31		4822 124 23053	ELECT 1μF 50V	EJ10505010
					CU32		4822 126 10408	CER. 220pF ±10% B 50V	DA16221110
					CU33		4822 122 33795	CER. 4700pF ±20% X 50V	DA17472110
					CU34		4822 126 10935	ELECT 100μF 6.3V	EJ10700610
					CU35		4822 122 40586	CER. 0.01μF ±20% Y 50V	DA17103110
					CU36		4822 124 22726	ELECT 4.7μF 35V	EJ47503510
					CU37		4822 124 22726	ELECT 4.7μF 35V	EJ47503510
					CU38		4822 122 40586	CER. 0.01μF ±20% Y 50V	DA17103110
					CU39		4822 122 40617	CER. 0.1μF +80%-20% 50V	DD38104010
					CU41		4822 126 10364	CER. 100pF ±10% B 50V	DA16101110
					CU42		4822 126 10364	CER. 100pF ±10% B 50V	DA16101110

(VERS.:VERSION, U:U.S.A., F:JAPAN, K:FAR EAST, **:EUROPE)

POS. NO	VERS. COLOR	PART NO. (FOR PCS)	DESCRIPTION	PART NO. (MJI)	POS. NO	VERS. COLOR	PART NO. (FOR PCS)	DESCRIPTION	PART NO. (MJI)
CU43		4822 126 10364	CER. 100pF ±10% B 50V	DA16101110	QU05	/2	4822 130 41947	TRS. 2SC2458 2SC1740S	HT30001000
CU44		4822 122 40586	CER. 0.01μF ±20% Y 50V	DA17103110				2SC3199 ETC.	
CU47		4822 122 40586	CER. 0.01μF ±20% Y 50V	DA17103110	QU06	/2	4822 130 61227	DIG.TR.S. DTA114ES UN4111	BA10001000
CU48	/2		CER. 1500pF ±20% X 50V	DA17152110				10K 10K	
CU53		4822 126 12867	ELECT. 1000μF 6.3V	OA10800600	QU07	/2	4822 209 17372	IC SAA6588 RDS DECODER	HC10174490
CU54		4822 122 40617	CER. 0.1μF +80 -20% 50V DC	DD38104010	QU08		4822 130 42715	TRS. 2SA1048 2SA933S	HT10001000
CU55	/2	4822 126 12496	CER. 0.01μF +80 -20% DC50V	DD38103010				2SA1267 ETC.	
CU56	/2	4822 126 12496	CER. 0.01μF +80 -20% DC50V	DD38103010	QU09		4822 130 42715	TRS. 2SA1048 2SA933S	HT10001000
CU57		4822 122 40617	CER. 0.1μF +80%-20% 50V	DD38104010				2SA1267 ETC.	
CU58		4822 122 40617	CER. 0.1μF +80%-20% 50V	DD38104010	QU10		4822 209 17376	MICROPROCESSOR	HU298JT000
CU59		4822 124 40786	ELECT 2.2μF 50V	EJ22505010				TMP87CS71F MR2020 E3E5	
CU61					QU14		4822 130 42682	DIG.TR.S. DTA144ES UN4113	BA10002000
CU64		4822 126 10408	CER. 220P ±10% 50V	DA16221110				47K 47K	
CU65		4822 122 40617	CER. 0.1μF +80%-20% 50V	DD38104010	QU16		4822 130 41947	TRS. 2SC2458 2SC1740S	HT30001000
								2SC3199 ETC.	
***			PU04-CAPACITORS (COMMON) PLASTIC FILM CAPACITOR ±5% 50V : [CU45 CU46 : KK U]		QU17		4822 130 42715	TRS. 2SA1048 2SA933S	HT10001000
					QU18		4822 130 41947	TRS. 2SC2458 2SC1740S	HT30001000
					QU19		4822 130 41947	TRS. 2SC2458 2SC1740S	HT30001000
					QU20		4822 130 42715	TRS. 2SA1048 2SA933S	HT10001000
RU55		4822 050 23308	3.3MΩ ±5% 1/6W	GD05335160				2SA1267 ETC.	
RU57		4822 050 23308	3.3MΩ ±5% 1/6W	GD05335160	QU21		4822 130 41947	TRS. 2SC2458 2SC1740S	HT30001000
RU64		4822 117 10158	1Ω 1/4W GG	GG05010140				2SC3199 ETC.	
RU65		4822 117 10158	1Ω 1/4W GG	GG05010140	QU22		4822 130 41947	TRS. 2SC2458 2SC1740S	HT30001000
RU67		4822 052 10101	100Ω ±5% 1/6W	GG05101160				2SC3199 ETC.	
RU88		4822 050 23308	3.3MΩ ±5% 1/6W	GD05335160	QU23		4822 130 43313	TRS. 2SC3312 2SC1740SLN	HT30002000
					QU24		4822 130 43313	TRS. 2SC3312 2SC1740SLN	HT30002000
***			PU04-RESISTORS (COMMON) CARBON FILM FIXED RES. ±5% 1/6W : RF01-RF16 RF19-RF26 RF28-RF32 RF51-RF62 RT61-RT64 RU01-RU04 [RU05 RU07-RU12 : /02] RU13-RU37 RU41-RU47 RU49 RU56 RU58-RU61 [RU62 : /02 U] [RU63 : /02 K KK] RU69 RU71-RU74 RU76-RU87 RU89-RU93 RU98 RU99		QU25		4822 130 43313	TRS. 2SC3312 2SC1740SLN	HT30002000
					QU26		4822 130 42715	TRS. 2SA1048 2SA933S	HT10001000
					QU29		4822 130 41947	TRS. 2SC2458 2SC1740S	HT30001000
					LU01	/2	4822 242 73843	PU04-MISCELLANEOUS EMI FILTER 0.022μF	FM12223010
					LU02	/2	4822 242 73843	EMI FILTER 0.022μF	FM12223010
					SU01				
							4822 276 20508	PUSH SW. EVO11L05R	SP01013370
					SU16				
DU01		4822 130 80837	DIODE HSS81TD 150V 150mA	HD20027010	VU01		4822 135 00271	DISPLAY UNIT FL FTABA 11-BT-164GK	HQ30806410
DU02		4822 130 80837	DIODE HSS81TD 150V 150mA	HD20027010					
DU03		4822 130 80837	DIODE HSS81TD 150V 150mA	HD20027010	XU01		4822 242 72236	CRYSTAL DT-38 32.768kHz	XO001001T2
DU04			JUMPER	75060501P0	XU02		4822 242 72066	SERAMVIB. CST8.0MHz MT	FQ08004010
DU05		4822 130 82421	DIODE 1D3 1A 200V	HD20002710	XU03	/2	4822 242 10857	CRYSTAL 4.332MHz AT-49	JX04003260
DU06		4822 130 32362	DIODE 1SS176 MA165 1SS254 30V 0.1A	HD20002000					
DU07		4822 130 32362	DIODE 1SS176 MA165 1SS254 30V 0.1A	HD20002000				PX04-SOUND CONT. H.P AMP CIRCUIT BOARD	
DU08		4822 130 32362	DIODE 1SS176 MA165 1SS254 30V 0.1A	HD20002000				PX04-CAPACITORS	
DU09		4822 130 80837	DIODE HSS81TD 150V 150mA	HD20027010	CE09		4822 124 22703	ELECT. 0.22μF ±20% 50V	OA22405020
DU10		4822 130 80837	DIODE HSS81TD 150V 150mA	HD20027010	CE10		4822 124 22703	ELECT. 0.22μF ±20% 50V	OA22405020
DU12		4822 130 80837	DIODE HSS81TD 150V 150mA	HD20027010	CE11		4822 124 22273	ELECT. 0.47μF ±20% 50V	OA47405020
DU13		4822 130 80837	DIODE HSS81TD 150V 150mA	HD20027010	CE12		4822 124 22273	ELECT. 0.47μF ±20% 50V	OA47405020
DU14		4822 130 80837	DIODE HSS81TD 150V 150mA	HD20027010	CE17		4822 122 40617	CER. 0.1μF +80 -20% 50V DC	DD38104010
DU15		4822 130 11585	L.E.D. SIM-22ST FOR DOOR JUMPER	HI20001210	CE18		4822 124 41539	ELECT. 47μF ±20% 16V RA-2	OA47601620
DU16				75060501P0	CE19		4822 124 41539	ELECT. 47μF ±20% 16V RA-2	OA47601620
QF51		4822 209 83631	IC NJM4558D-D	HC10008090	CE20		4822 124 90354	ELECT. 100μF 16V	OA10701620
QU01		4822 130 11586	PHOTO UNIT RPM-22PB PHOTO-DOOR	HW10006210	CE21		4822 124 90354	ELECT. 100μF 16V	OA10701620
QU02		4822 130 91368	PHOTO UNIT NJL5165KL DISC SENSOR	HW10004090	CE27		4822 121 42327	FILM 470pF ±5% 50V	DF15471350
QU03		4822 130 42715	TRS. 2SA1048 2SA933S 2SA1267 ETC.	HT10001000	CE28		4822 121 42327	FILM 470pF ±5% 50V	DF15471350
QU04		4822 130 61892	TRS. 2SD2144S U V	HT421442A0	CE31		4822 121 42327	FILM 470pF ±5% 50V	DF15471350
					CE32		4822 121 42327	FILM 470pF ±5% 50V	DF15471350
					CE35		4822 124 41543	ELECT. 1μF ±20% 50V RA-2	OA10505020
					CE36		4822 124 41543	ELECT. 1μF ±20% 50V RA-2	OA10505020
					CE37		4822 121 42327	FILM 470pF ±5% 50V	DF15471350
					CE38		4822 121 42327	FILM 470pF ±5% 50V	DF15471350
					CE41		4822 121 42327	FILM 470pF ±5% 50V	DF15471350
					CE42		4822 121 42327	FILM 470pF ±5% 50V	DF15471350

Service Manual

74 LS2021 /9M
LS2021 F,K,KK,U
Speaker System



(VERS. :VERSION, U:U.S.A., F:JAPAN, K:FAR EAST, /X: EUROPE)

POS. NO	VERS. COLOR	PART NO. (FOR PCS)	DESCRIPTION	PART NO. (MJI)
LS01		4822 240 10354	LOUDSPEAKER, TWEETER	*QK000030R
LS02		4822 240 10355	LOUDSPEAKER, WOOFER	*QK000040R
LS03		4822 265 11569	SPEAKER TERMINAL	*YT001430R

Please use this service manual with referring to the user guide (D.F.U.) without fail.

marantz®

system LS2021