



1530/MR230/MR235



marantz

model 1530/MR230/MR235

Stereophonic Receiver

MARANTZ DESIGN AND SERVICE

Using superior design and selected high grade components, MARANTZ Company has created the ultimate in stereo sound. Only original MARANTZ parts can insure that your MARANTZ product will continue to perform to the specifications for which it is famous.

Parts for your MARANTZ stereo are generally available within 72 hours throughout the nation via a toll-free line to our National Parts Depot in California. The sales professionals who take your call immediately refer to their own desk top computer terminal and can quickly determine the availability and price information you require. If, for some reason, your order should exceed our available stock, we usually can instantly provide an alternate replacement part or current delivery information. When the order is placed and confirmed, the computer simultaneously generates "hard copy" orders at the distribution center. As hard copies come directly from the computer to the national parts depot, your requested stock is assembled and prepared for shipment and placed on the first available carrier for delivery to you.

ORDERING PARTS

Phone orders will eliminate mail delays, and we encourage the use of this method. If you order by mail, use MARANTZ parts order forms which are available from our National Parts Depot located at the following address:

SUPERSCOPE NATIONAL PARTS DEPARTMENT
20525 Nordhoff Street
Chatsworth, California 91311
Phone: 1-800-423-5108
1-213-998-9333

The following information must be supplied to eliminate delays in processing your order:

1. Complete address.
2. Complete part numbers.
3. Complete description of parts.
4. Model number for which part is required (indicate MARANTZ).
5. Account number (for account customers only).

Direct consumers will be provided with the current retail price quotation on available parts in order to advise them of the cost of the parts and shipping.

OVERSEAS PARTS ORDERING

Parts may also be ordered from the following overseas addresses:

CANADA

Superscope Canada, Ltd.
3710 Nashua Drive
Mississauga
Ontario, Canada L4V1M5

AUSTRALIA

Superscope (Australasia) Pty., Ltd.
32 Cross Street (P.O. Box 604)
Brookvale 2100 N.S.W.
Australia

JAPAN

Marantz Japan, Inc.
3622 Kamitsuruma
Sagamihara Shi
Kanagawa, Japan

EUROPE

Superscope Europe, S.A.
Avenue Leopold III, 2
7120 Perennes-Lez-Binche
Belgium

Marantz France
Rue Louis Armand 9
92600 Asnieres
Hauts-de-Seine
France

Marantz Audio U.K. Ltd.
London Road, 203
Staines
Middlesex
England

Superscope GmbH
Max-Planck-Strasse 12
D-6072 Dreieich 1
West Germany

All of the above locations are fully equipped to take care of your total service needs. Because various countries have differing configuration requirements, it is necessary that you contact the service facility in your particular country. In the event that there is no service location listed for your country, please contact the nearest facility for the necessary assistance.

TABLE OF CONTENTS

Section	Title	Page
1.	P.W. BOARDS	1
2.	TEST EQUIPMENT REQUIRED FOR SERVICING	2
3.	ALIGNMENT PROCEDURES	3
3.1	FM Alignment Procedures	3
3.2	Multiplex Alignment Procedures	4
3.3	AM Alignment Procedures	4
3.4	Audio Alignment Procedures	5
4.	VOLTAGE CONVERSION	5
5.	DIAGRAMS	6
5.1	Block Diagram	6
5.2	Tuner Board Schematic Diagram and Component Locations - P100	8
5.3	Phono Amp Board Schematic Diagram and Component Locations - P400	10
5.4	Main Amp & Power Supply Board Schematic Diagram and Component Locations - P700	11
5.5	Antenna Input Board Schematic Diagram and Component Locations - PC00	12
5.6	Tone Amp Board Schematic Diagram and Component Locations - PE00	12
5.7	Power Transistor Board Schematic Diagram and Component Locations - PN01	12
5.8	Filter & Switch Board Schematic Diagram and Component Locations - PS00	13
5.9	LED Board Schematic Diagram and Component Locations - PY01	13
6.	EXPLODED VIEWS AND PARTS LIST	14
6.1	[C01-99] Front Panel	14
6.2	[C02-99] Lid (Top Cover)	15
6.3	[C03-99] Rear Panel	16
6.4	[P01-99] Front Chassis and General Parts	17
6.5	[P02-99] Assembled P.W. Boards and Other Parts	18
6.6	[H01-99] Packing Materials	20
6.7	Electrical Parts List	21
7.	TECHNICAL SPECIFICATIONS	27

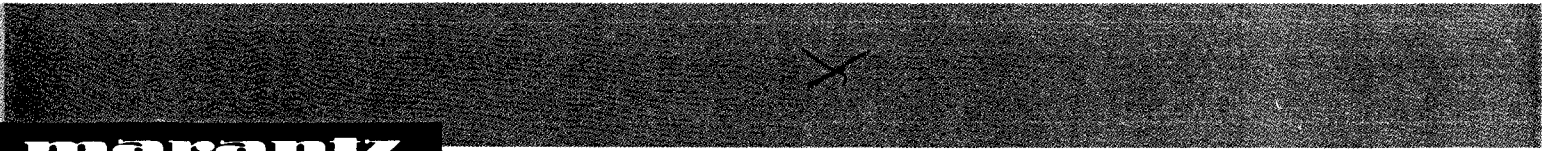

MODEL 1530/MR230/MR235 STEREOPHONIC RECEIVER

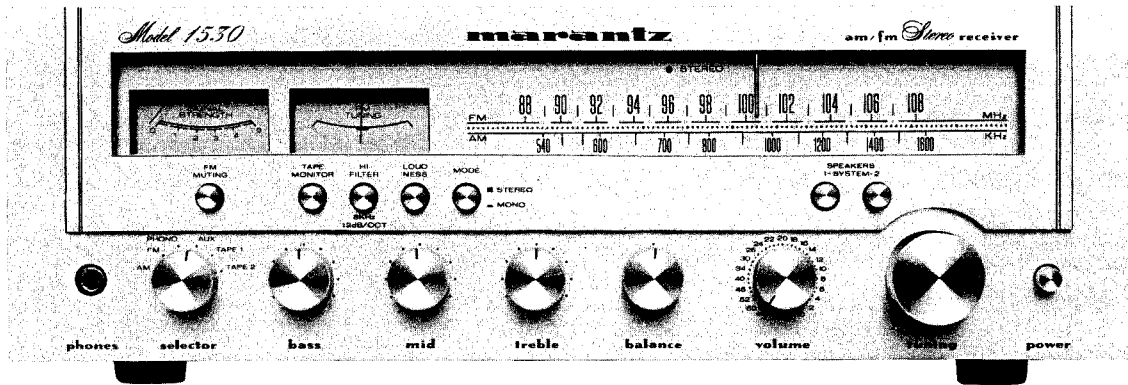

INTRODUCTION

This service manual was prepared for use by Authorized Warranty Stations and contains service information for Marantz Model 1530/MR230/MR235 Stereophonic Receiver.

Servicing information and voltage data included in this manual are intended for use by the knowledgeable and experienced technician only. All instructions should be read carefully. No attempt should be made to proceed without a good understanding of the operation of the receiver.

The parts list furnishes information by which replacement parts may be ordered from the Marantz Company. A simple description is included for parts which can usually be obtained through local suppliers.

1. P.W. BOARDS

As can be seen from the circuit diagram, the chassis of Model 1530/MR230/MR235 consists of the following units. Each unit mounted on a printed circuit board is described within the square enclosed by a bold dotted line on the circuit diagram.

1. Tuner mounted on P.W. Board P100
2. Phono Amp mounted on P.W. Board P400
3. Main Amp &
Power Supply mounted on P.W. Board P700
4. Antenna Input mounted on P.W. Board PC00
5. Tone Amp mounted on P.W. Board PE00
6. Power Transistor mounted on P.W. Board PN01
7. Fuse mounted on P.W. Board PP01
8. Filter & Switch mounted on P.W. Board PS00
9. LED mounted on P.W. Board PY01

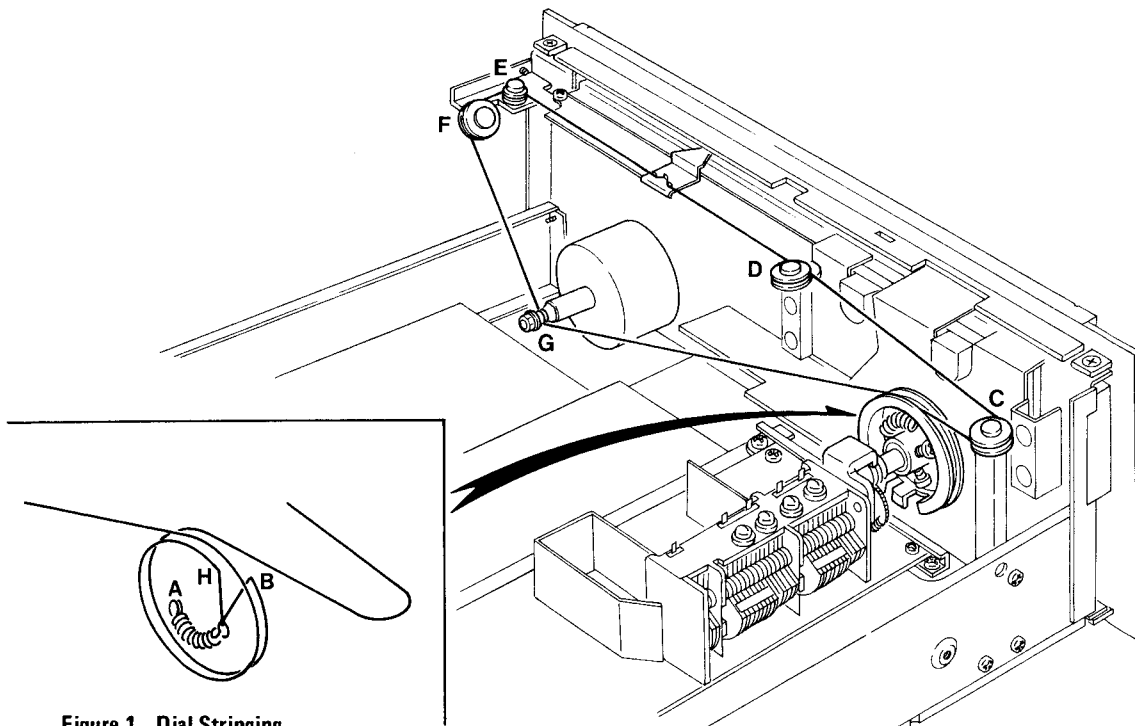

Figure 1. Dial Stringing

2. TEST EQUIPMENT REQUIRED FOR SERVICING

This table lists the test equipment required for servicing the Model 1530/MR230/MR235 Receiver.

Item	Manufacturer and Model No.	Use
AM Signal Generator		Signal source for AM alignment
Test Loop		Use with AM Signal Generator
FM Signal Generator MPX Signal Generator	Sound Technology Model 1000A	Signal source for FM alignment Stereo separation alignment and trouble shooting
Distortion Analyzer Audio Oscillator AC VTVM	Sound Technology Model 1700A	Distortion measurements Sinewave and squarewave signal source Voltage measurements (AC)
Oscilloscope	Tektronix Model T932 Philips Model 3232	Waveform analysis and trouble shooting and ASO alignment
Frequency Counter	Fluke Model 1900A	MPX Oscillator adjustment (VCO)
Circuit Tester		Trouble shooting
DC VTVM	Fluke Model 8000 "Digital" Simpson Model 313, Triplet Model 801	Voltage measurements (DC)
AC Wattmeter	Simpson Model 1379	Monitors primary power to amplifier
AC Ammeter	Commercial Grade (1-10A)	Monitors amplifier output under short circuit condition
Line Voltmeter	Simpson Model 1359	Monitors potential of primary power to amplifier
Variable Autotransformer	Superior Electronic Co., Powerstat Model 116B-10A	Adjusts level of primary power to amplifier
Shorting Plug	Use phono plug with 600-ohm across center pin and shell	Shorts amplifier input to eliminate noise pickup
Output Load (8 ohms, ± 0.5%, 100W)	Commercial Grade	Provides 8-ohm load for amplifier output termination
Output Load (4 ohms, ± 0.5%, 100W)	Commercial Grade	Provides 4-ohm load for amplifier output termination

FTZ REGULATION

Instruction for the use in the range other than specified in FTZ codes.

Achtung für die Leute, die in dem Gebiet wohnen, wo die FTZ-Bestimmungen vorherrschend sind.

Sollte das Gerät auch für Frequenzen ausserhalb des in den FTZ-Bestimmungen angegebenen Bereiches empfangerecht sein, bitten wir, den Bereich durch Nachstellen des Kernes in der Oszillatortspule (in der Abbildung mit "FTZ" gekennzeichnet) so zu korrigieren, dass er den Bestimmungen entspricht.

3. ALIGNMENT PROCEDURES

* A dummy resistor of 47 kohms must be connected across the tape output terminals before alignment.

3.1 FM ALIGNMENT PROCEDURES

(Selector switch in the "FM" position)

Step	Signal Source Connection	Signal Frequency	Indicator Connection	Set Dial Pointer to:	Adjust:
FM IF ALIGNMENT					
1	Sweep generator to point (B) through 5pF capacitor	10.7 MHz market at 10.6, 10.7 and 10.8 MHz	Oscilloscope to point (C)	Quiet point on band.	L104 for maximum and symmetric response.
2			Oscilloscope to point (D)		L201 for straight and symmetric "S" curve response.
3	Repeat steps 1 and 2.				
FM RF ALIGNMENT					
1	RF generator to FM antenna terminals (A) through matching network (300 ohms, balanced) Maintain RF level below limit.)	87.4 MHz	VTVM to L or R channel output (W002)	87.4 MHz with tuning gang closed.	L103 for maximum output.
2		100 MHz		109 MHz with tuning gang open.	C119 for maximum output.
3		90 MHz		90 MHz	L101, L102 for maximum output.
4		106 MHz		106 MHz	Ant. RF trimmer for maximum output.
5	Repeat steps 1 to 4.				
6	Check overall response curve and repeat above steps as necessary to obtain maximum sensitivity.				
7	No connection	No signal	DC VTVM 1-volt range to (D)	—	L201 primary core (bottom) for "0" voltage reading.
8	RF generator 1 mV output to FM antenna terminals (A) through matching network (300 ohms, balanced)	98 MHz	Distortion meter to (D)	98 MHz	L201 secondary core (upper) for minimum distortion.
9			—		R232 so that signal strength meter M00 1 may read 85%.
MUTING CIRCUIT ALIGNMENT					
1	RF generator 12.5 μ V output to FM antenna terminals (A) through matching network (300 ohms, balanced)	98 MHz	VTVM to R or L channel output (W002)	98 MHz	R233 for 12.5 μ V threshold level. (During the adjustment turn the muting pushswitch "ON").

3.2 MULTIPLEX ALIGNMENT PROCEDURES

(Selector switch in the "FM" position)

Step	Signal Source Connection	Signal Frequency	Indicator Connection	Set Dial Pointer to:	Adjust:
1	RF generator to FM antenna terminals (A) through matching network (300 ohms, balanced), with 1mV FM stereo simulator RF level and 100% modulation (pilot 9%)	No modulation	Frequency counter to point (E) (J140)	98 MHz	R326 so that frequency counter may precisely read 19 kHz.
2		Stereo, left (1,000 Hz)	VTVM to right channel output (W002, White)		R316 for maximum output and same separation in both channels.
3		Stereo, right (1,000 Hz)	VTVM to left channel output terminal (H) (J123) (W002, Red)		
4	Repeat steps 2 and 3.				

3.3 AM ALIGNMENT PROCEDURES

(Selector switch in the "AM" position)

Step	Signal Source Connection	Signal Frequency	Indicator Connection	Set Dial Pointer to:	Adjust:
AM IF ALIGNMENT					
1	No connection	No signal	—	—	R228 to that signal strength meter M001 may read 0.
2	Sweep generator to point (F)	455 kHz marker	Oscilloscope to point (G) (J141)	Quiet point on band.	L154 for maximum and symmetric response.
AM RF ALIGNMENT					
1	RF generator to AM antenna terminals through IHF dummy	515 kHz	VTVM to L or R channel output (W002)	515 kHz with tuning gang closed.	L153 for maximum output.
2		1,650 kHz		1,650 kHz with tuning gang open.	OSC. trimmer for maximum output.
3		600 kHz		600 kHz	L001 for maximum output.
4		1,400 kHz		1,400 kHz	Ant. trimmer for maximum output.
5	Repeat steps 1 to 4 as necessary to obtain maximum sensitivity.				

3.4 AUDIO ALIGNMENT PROCEDURES
(Selector switch in the "AUX" position)

	Signal Source Connection	Signal	Indicator Connection	Adjustment
Distortion meter used	AF oscillator to AUX jack	20 kHz	Distortion meter to SPK OUT terminals with 4Ω load.	Wait 2 min. after power has been on. Adjust R717 and R718 until distortion for 0.25W output is minimum. CAUTION: After adjustment, disconnect input signal, and make certain that current flowing from R741 to R744 is 10 to 30 mA.
Voltmeter used	—	—	DC voltmeter in 100 mV or 50 mV range to R741 (R743) and R742 (R744).	Adjust R717 and R718 until current is 10 mA.

4. VOLTAGE CONVERSION

The Model 1530/MR230/MR235 is equipped with a universal power transformer that may be adjusted to operate at 110 V, 120 V, 220 V, or 240 V AC at 50 to 60 Hz. To convert the unit to a different power source voltage, reposition conversion plug as shown in Figure 2.

CAUTION: DISCONNECT POWER SUPPLY CORD FROM AC OUTLET BEFORE CONVERTING VOLTAGE.

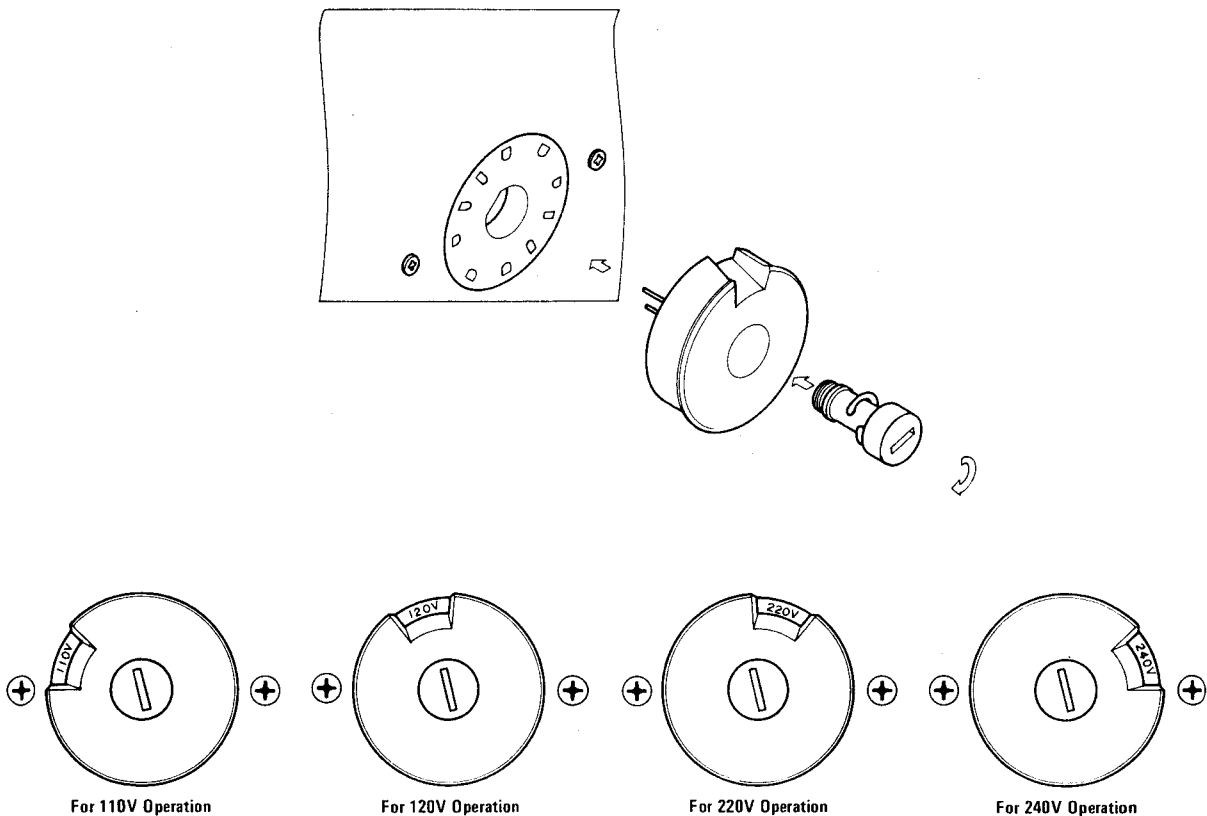
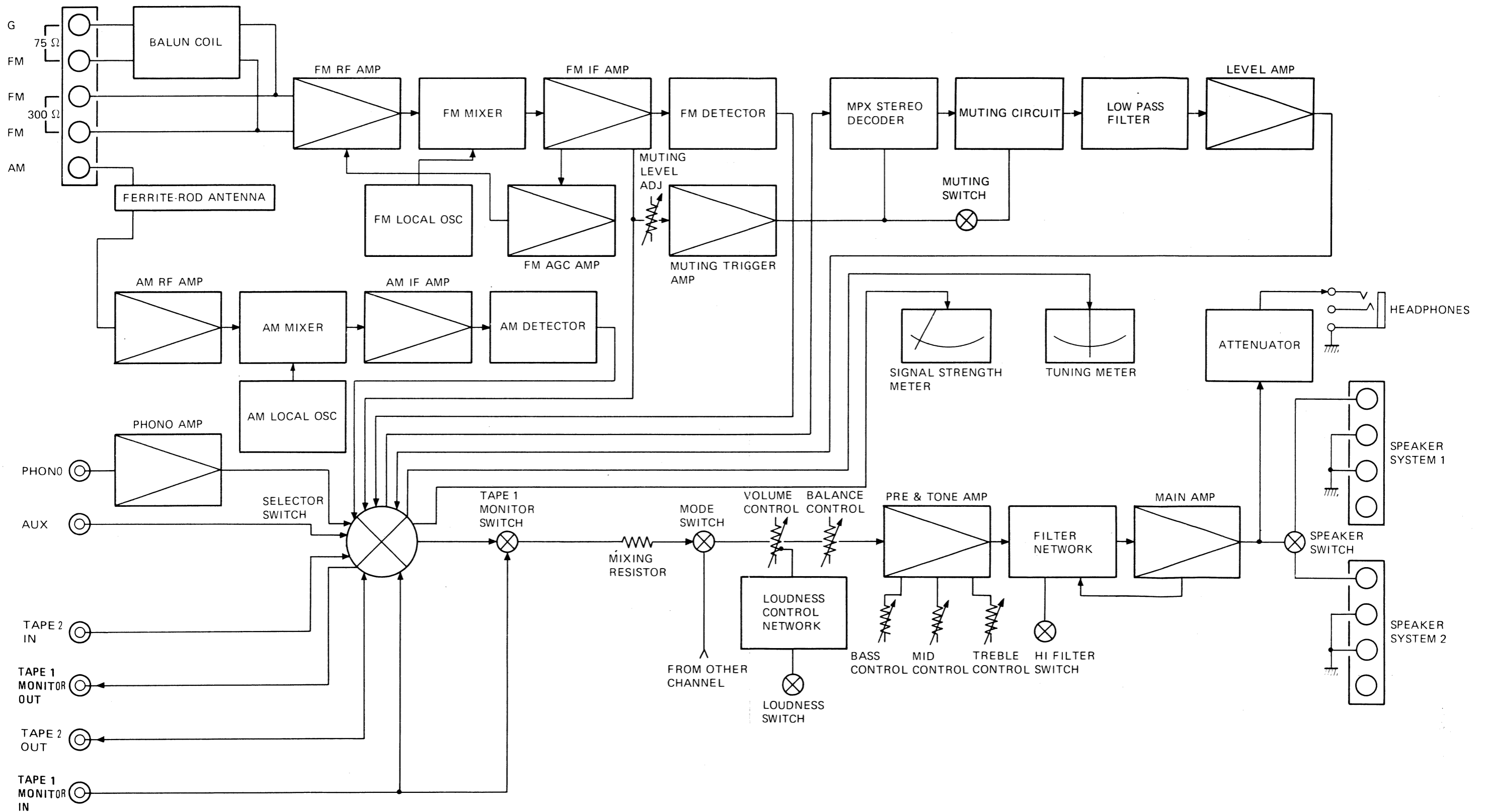

Figure 2. Voltage Conversion Chart

5. DIAGRAMS

5.1 BLOCK DIAGRAM



5.2 TUNER BOARD SCHEMATIC DIAGRAM AND COMPONENT LOCATIONS - P100

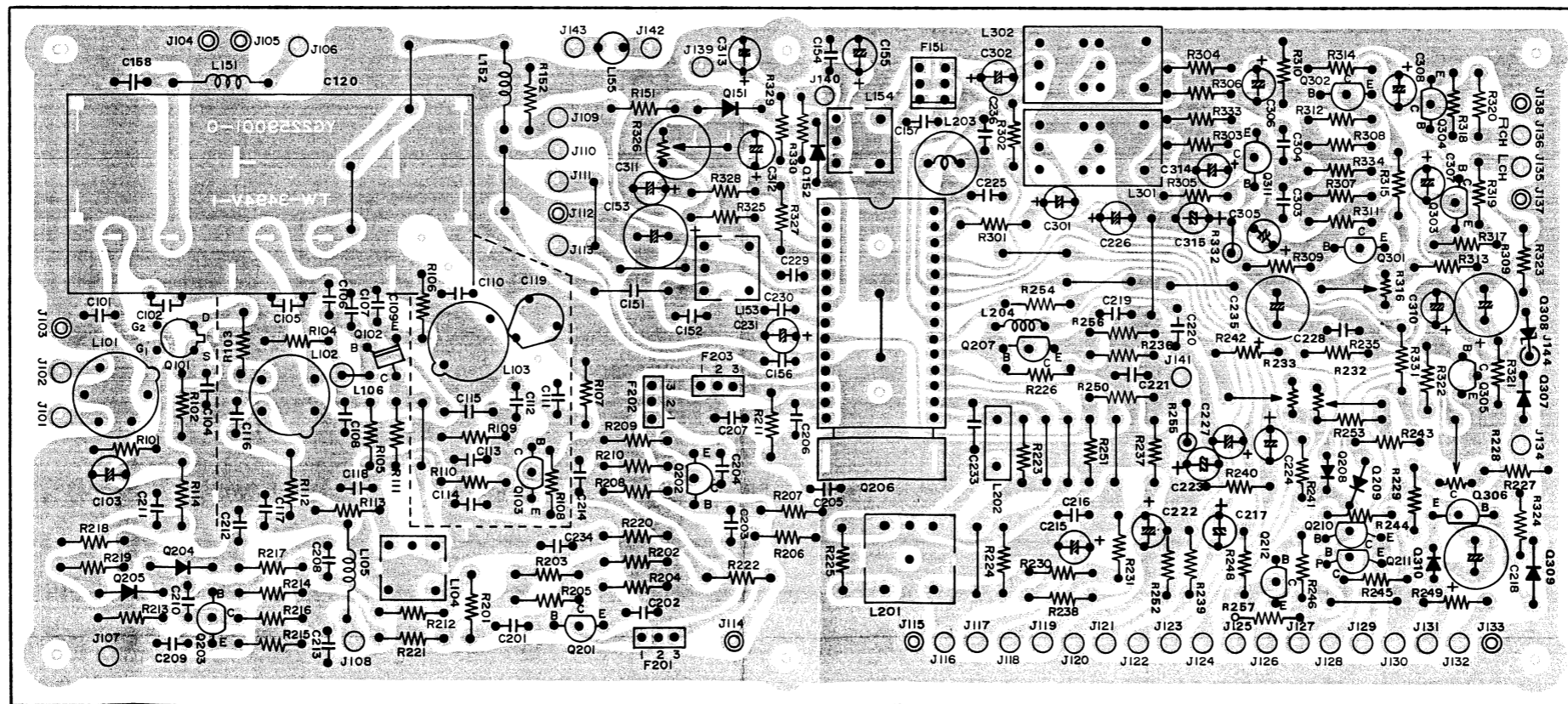
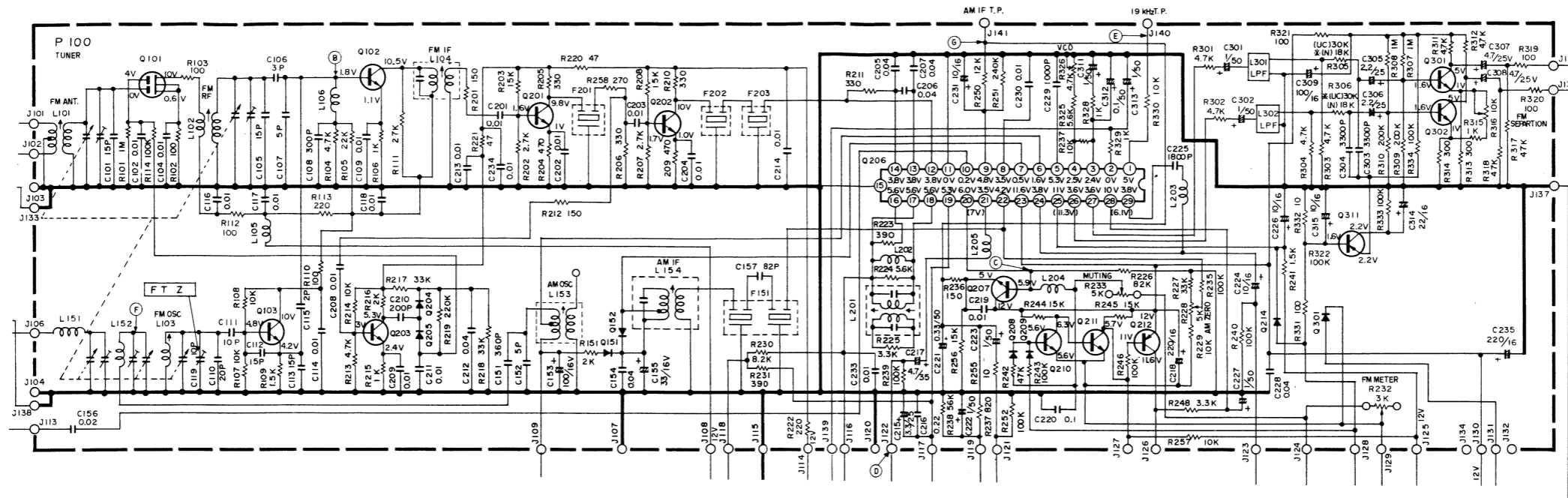

5.3 PHONO AMP BOARD SCHEMATIC DIAGRAM AND COMPONENT LOCATIONS - P400

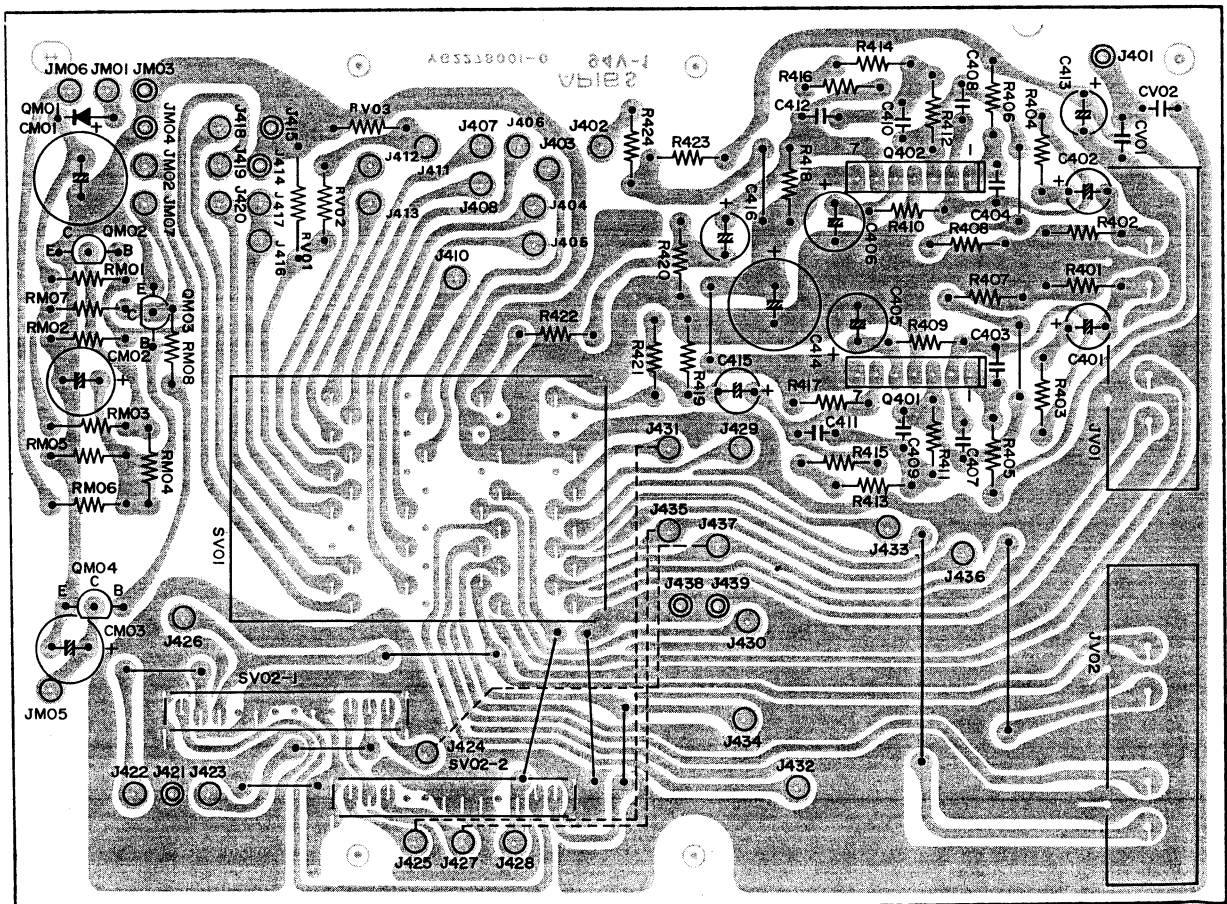
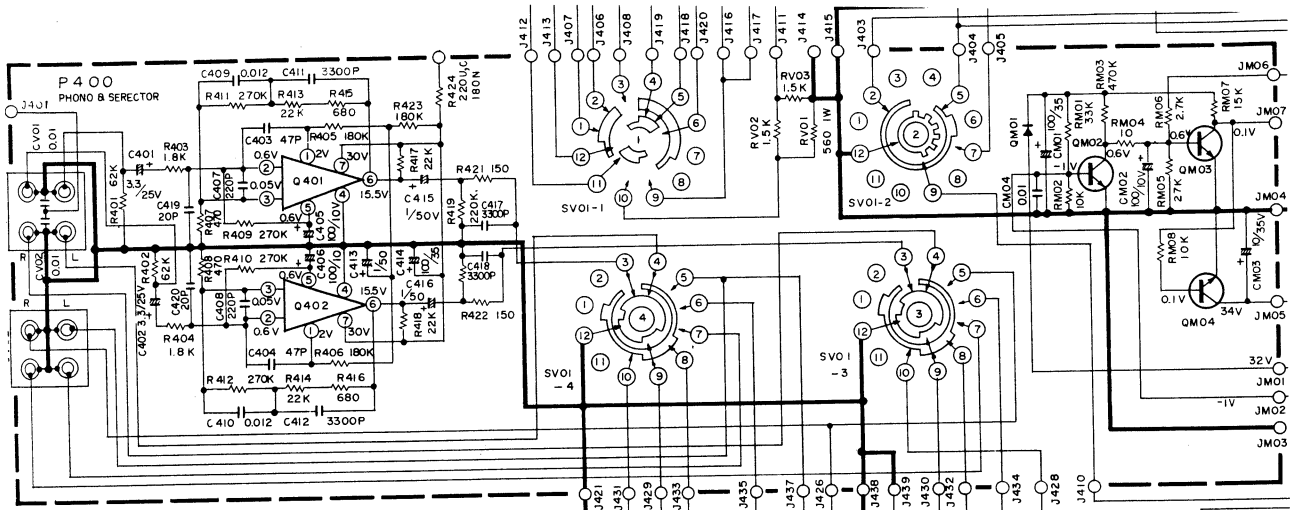

5.4 MAIN AMP & POWER SUPPLY BOARD SCHEMATIC DIAGRAM AND COMPONENT LOCATIONS - P700

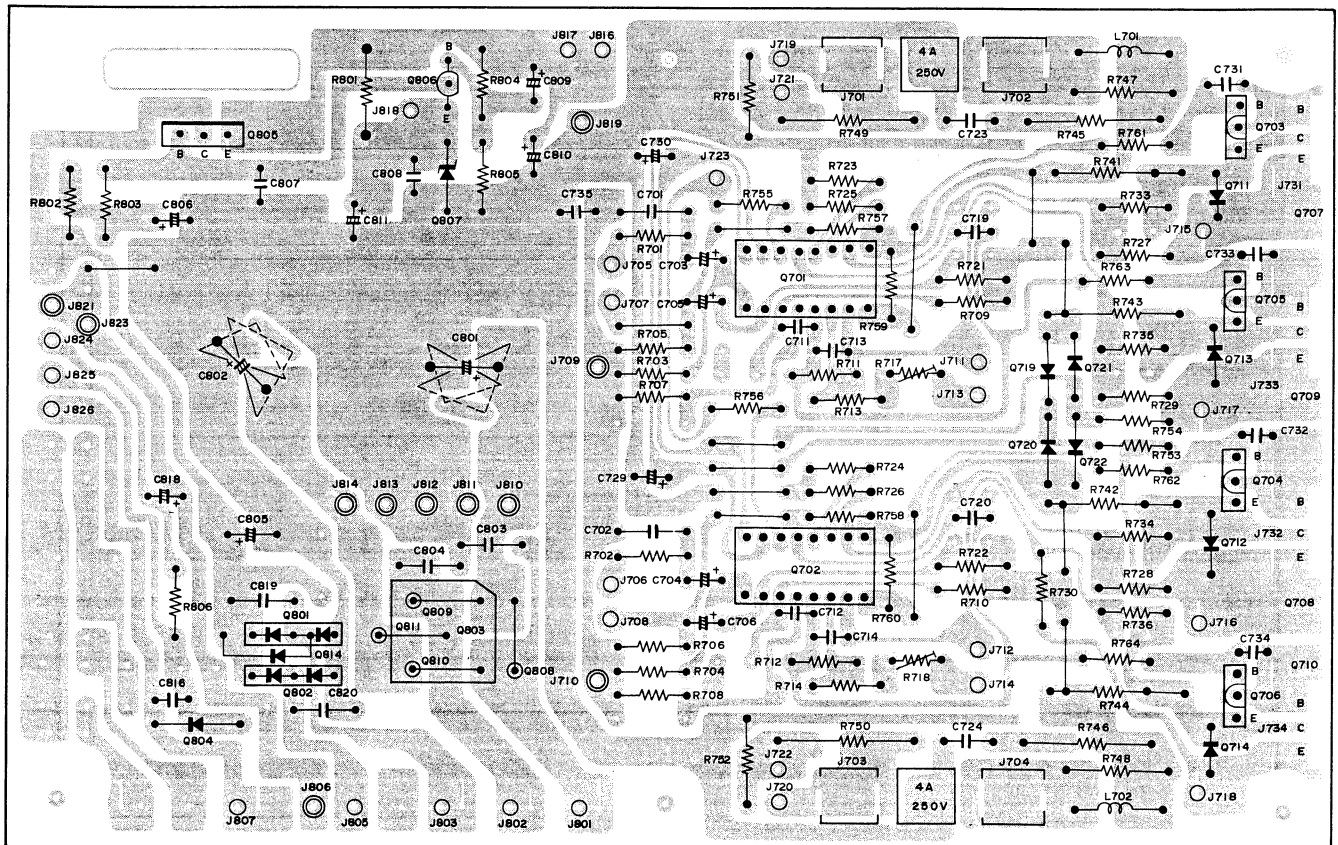
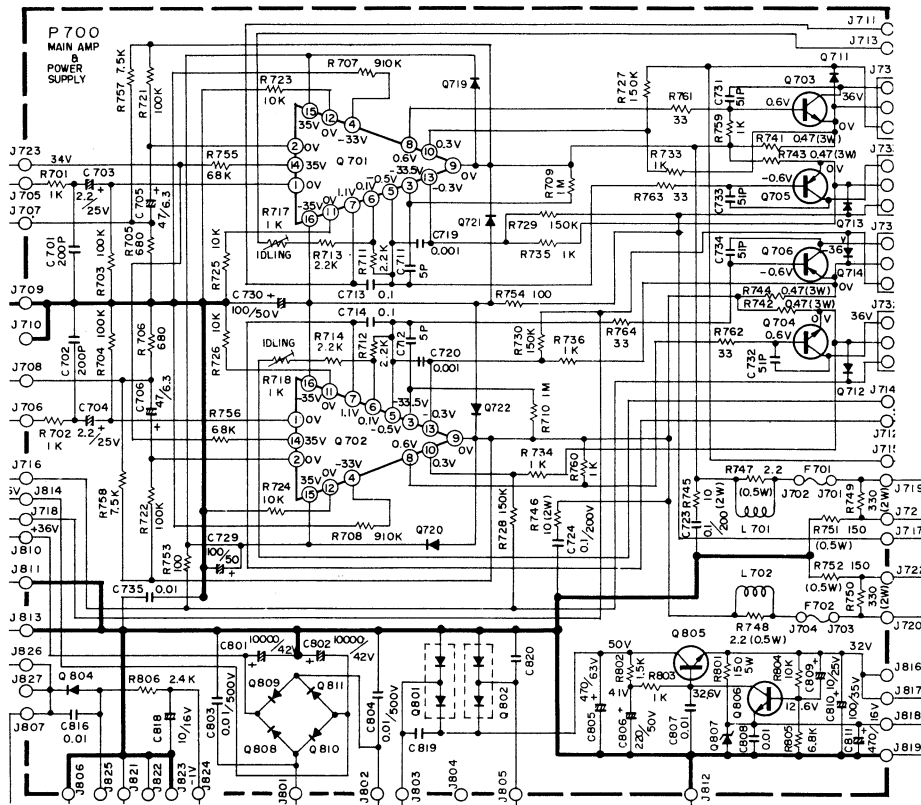

5.5 ANTENNA INPUT BOARD SCHEMATIC DIAGRAM AND COMPONENT LOCATIONS - PC00

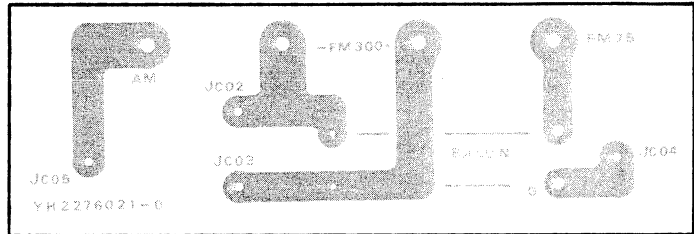
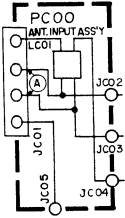

5.6 TONE AMP BOARD SCHEMATIC DIAGRAM AND COMPONENT LOCATIONS - PE00

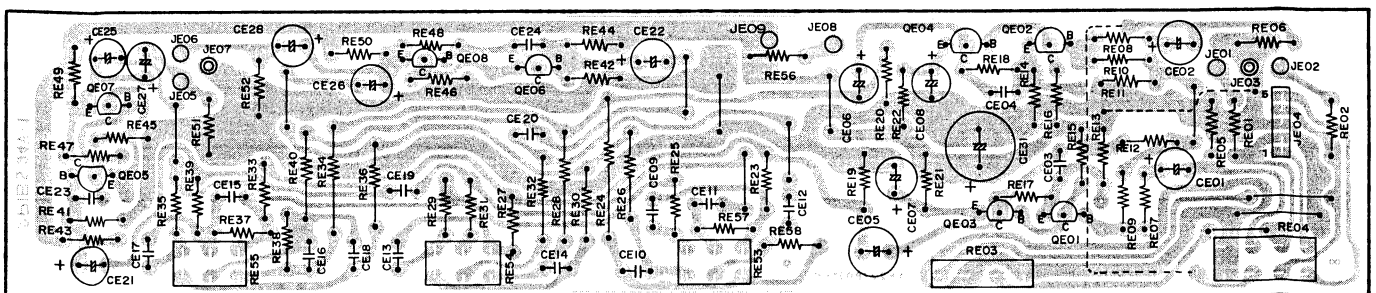
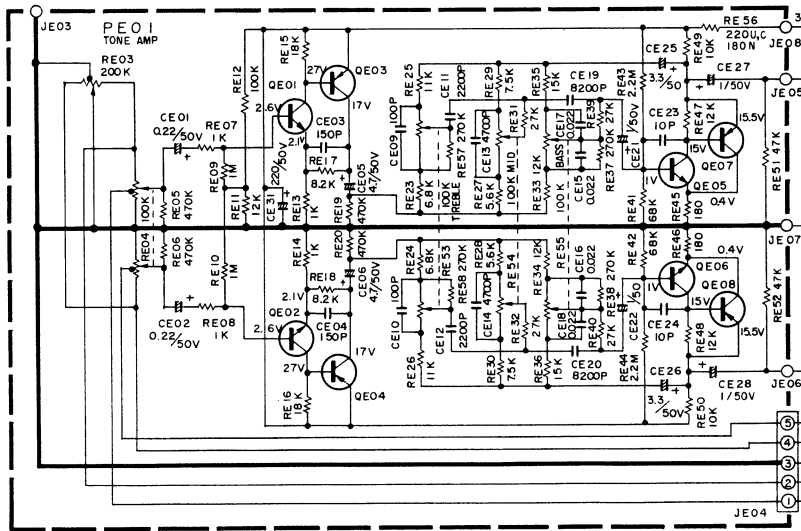

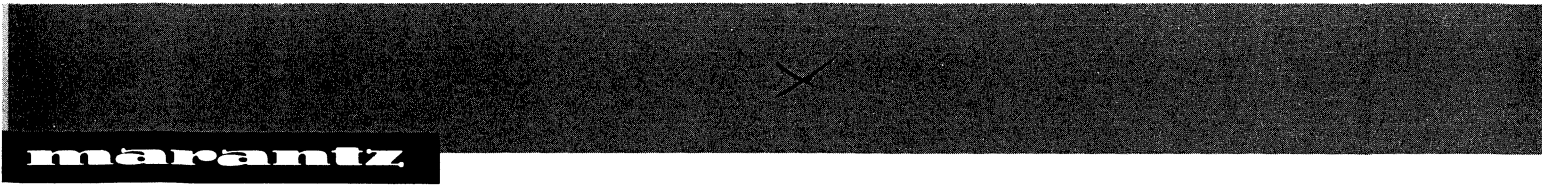

5.7 POWER TRANSISTOR BOARD SCHEMATIC DIAGRAM AND COMPONENT LOCATIONS - PN01

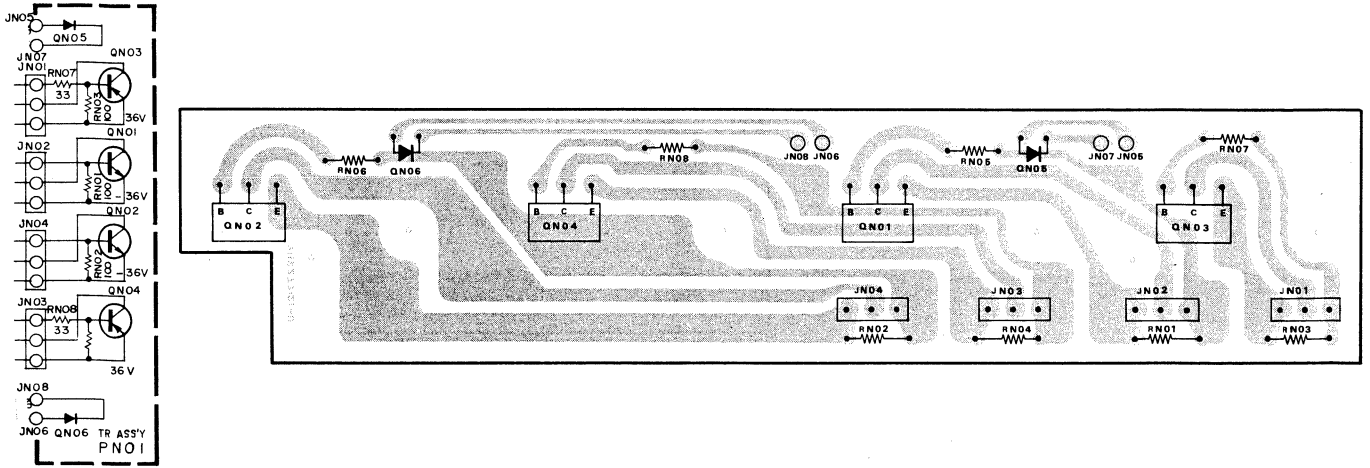

5.8 FILTER & SWITCH BOARD SCHEMATIC DIAGRAM AND COMPONENT LOCATIONS - PS00

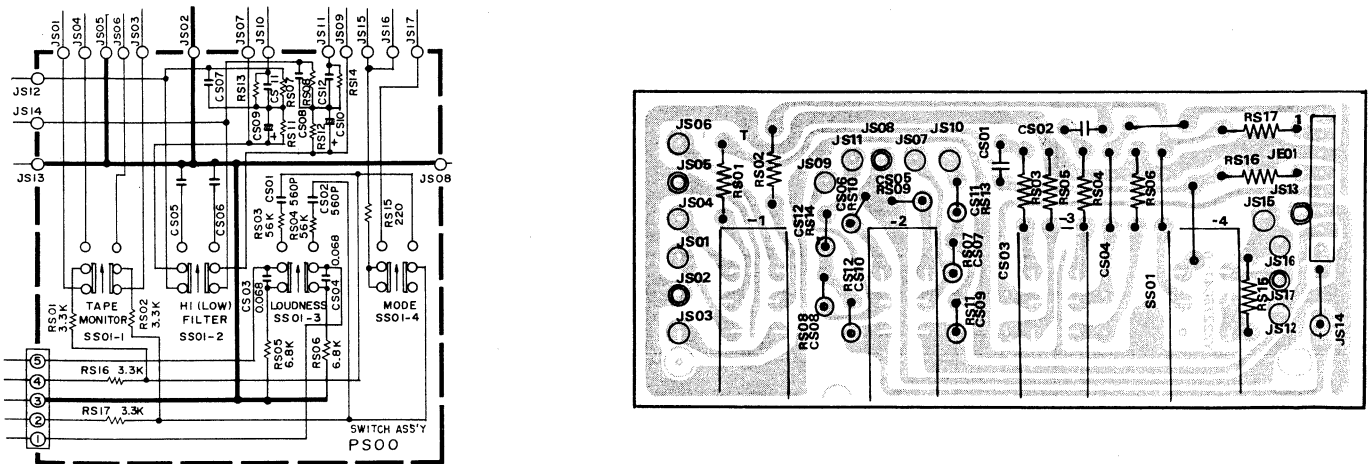

5.9 LED BOARD SCHEMATIC DIAGRAM AND COMPONENT LOCATIONS - PY01

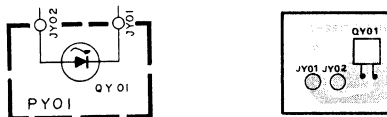

6. EXPLODED VIEWS AND PARTS LIST

6.1 [C01-99] FRONT PANEL

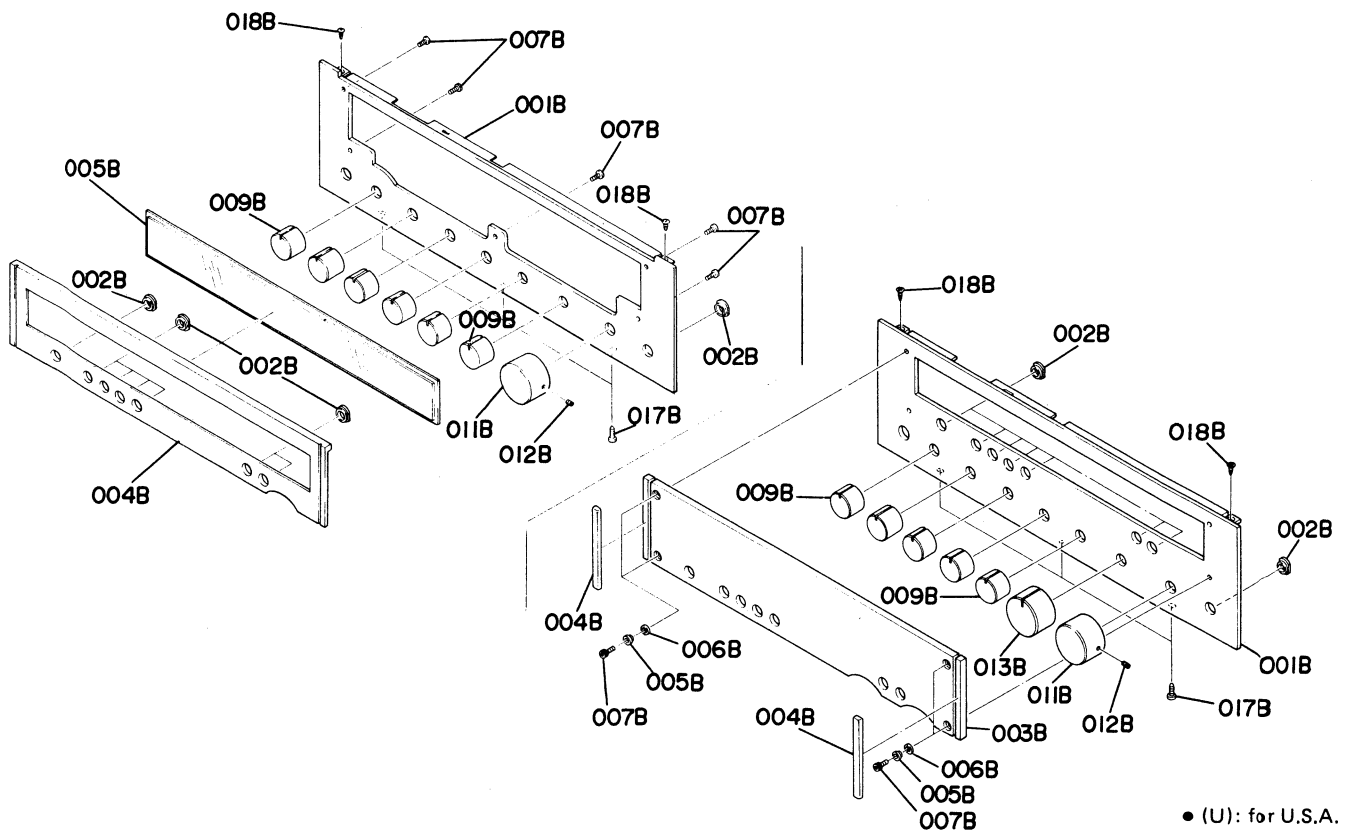

- (U): for U.S.A.
- (C): for Canada
- (N): for Europe

REF. DESIG.	Q'TY			PART NO.	DESCRIPTION
	U	C	N		
M1530, ONLY					
A	1	1		2277063400	Front Panel Assembly
A1			1	2277063410	Front Panel Assembly
001B	1	1	1	2278063012	Escutcheon, Main
002B	8	8	8	2978259012	Bush
004B	1	1		2277063122	Escutcheon, Sub
004B			1	2277063220	Escutcheon, Sub
005B	1	1	1	2211158110	Window
007B	5	5	5	51100305A9	B.H.M. Screw B3 x 5
MR230, ONLY					
A			1	2469063400	Front Panel Assembly
001B			1	2469063012	Escutcheon
002B			8	2978259012	Bushing
003B			1	2469158012	Window
004B			2	2276067010	Cap
005B			4	2470055010	Collar
006B			4	4214107010	Sheet
007B			4	52730308S9	H.S. Head Bolt H3 x 8
MR235, ONLY					
A	1			2277063420	Front Panel Assembly
001B	1			2278063012	Escutcheon Main
002B	8			2978259012	Bushing
004B	1			2277063130	Escutcheon, Sub
005B	1			2211158110	Window
007B	5			51100305A9	B.H.M. Screw B3 x 5

REF. DESIG.	Q'TY			PART NO.	DESCRIPTION
	U	C	N		
009B	6	6	6	2276154010	Knob (M1530, ONLY)
009B			5	2276154010	Knob (MR230, ONLY)
011B	1	1	1	2279154040	Knob, Tuning
012B	1	1	1	51690306Q9	Socket Screw, HP 3 x 6
013B			1	2276154030	Knob, Volume (MR230, ONLY)
017B	3	3	3	51280308U0	B.H. Tapped Screw B3 x 8
018B	2	2	2	51340306B0	F.H. Tapped Screw B3 x 6
M1530 (U)(C)(N)					
MR230 (N), ONLY					
MR235 (U), ONLY					

6.2 [C02-99] LID (TOP COVER)

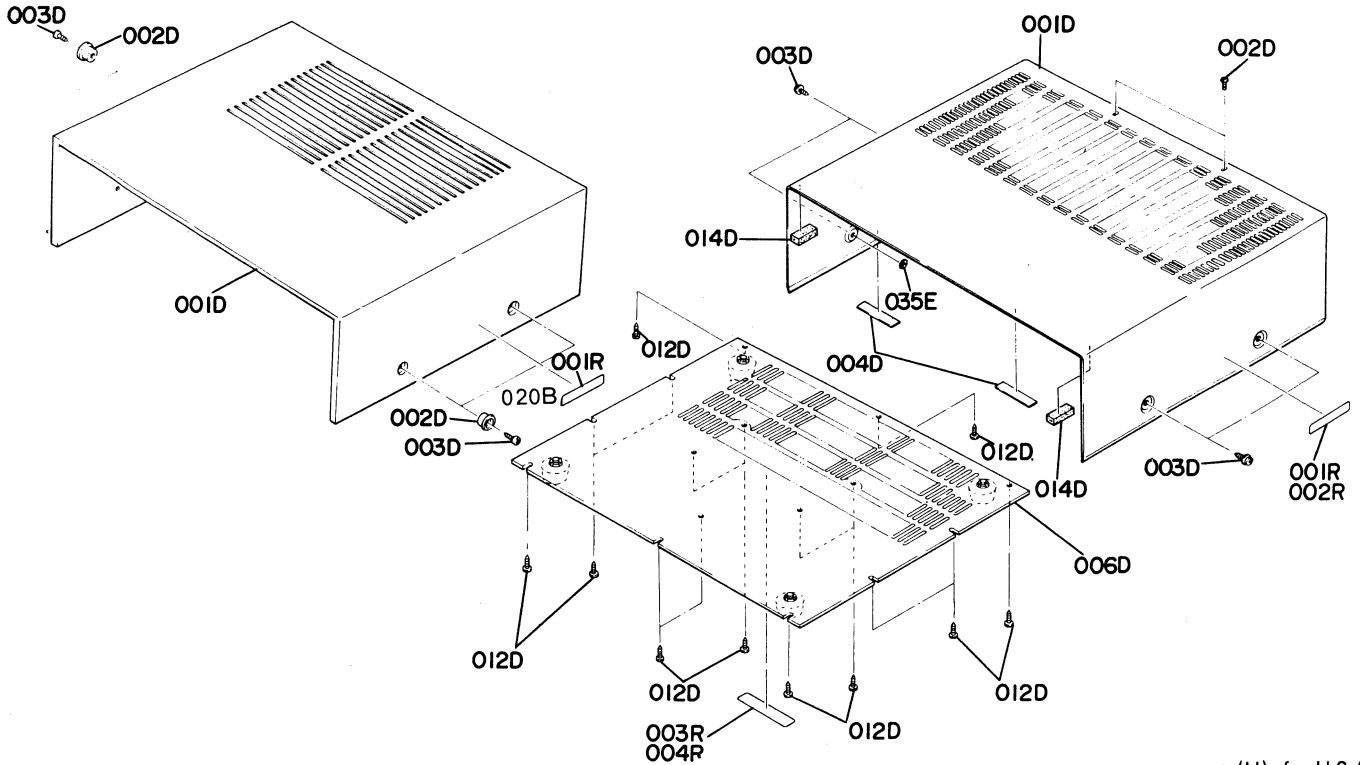

- (U): for U.S.A.
- (C): for Canada
- (N): for Europe

REF. DESIG.	Q'TY			PART NO.	DESCRIPTION
	U	C	N		
M1530, ONLY					
001D	1	1	1	2278257020	Lid, Metal Case
002D	2	2	2	51280306U0	B.H. Tapped Screw B3 x 6
003D	4	4	4	51260408U0	F. Washer Screw F4 x 8
004D	2	2	2	2965118010	Spacer
014D	2	2	2	3358118080	Spacer
MR230(N), MR235 (U)					
001D	1		1	2278064012	Case, Wood
002D	4		4	3906259010	Bushing
003D	4		4	51280412U0	B.H. Tapped Screw B4 x 12
020B	1			2818861010	Label

REF. DESIG.	Q'TY			PART NO.	DESCRIPTION
	U	C	N		
006D	1	1	1	2278257503	Lid, Bottom
012D	15	15	15	51280410U0	B.H. Tapped Screw B4 x 10
001R	1		1	2932861012	Label
002R		1		2911861143	Label
003R	1		1	2578861010	Label
004R		1		2911861112	Label
035E			1	54050400R0	T.L. Washer OR (M1530, ONLY)
M1530 (U)(C)(N) MR230 (N), ONLY MR235 (U), ONLY					

• (U): for U.S.A.
 • (C): for Canada
 • (N): for Europe

6.5 [P02-99] ASSEMBLED P.W. BOARD AND OTHER PARTS

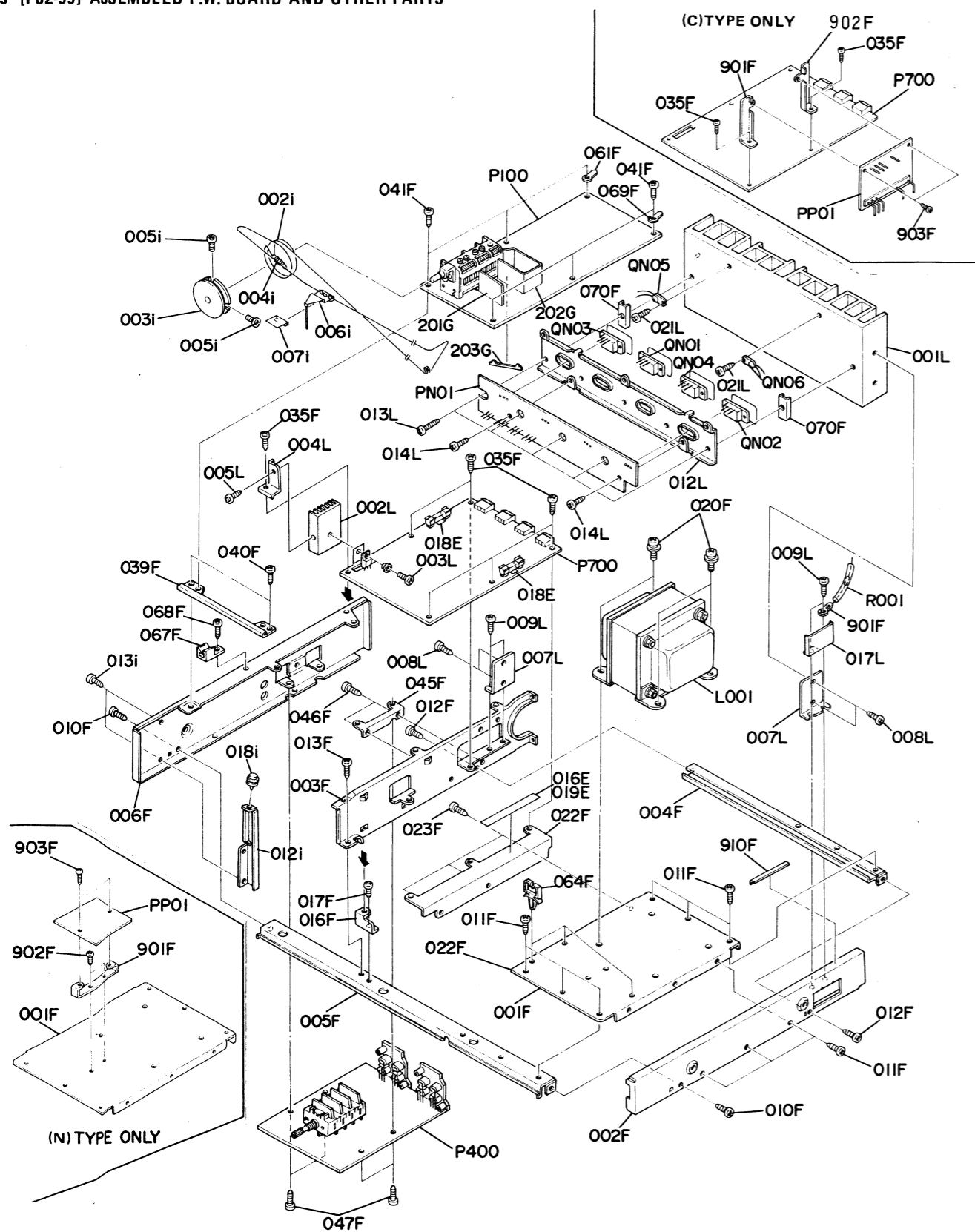

6.6 [H01-99] PACKING MATERIALS

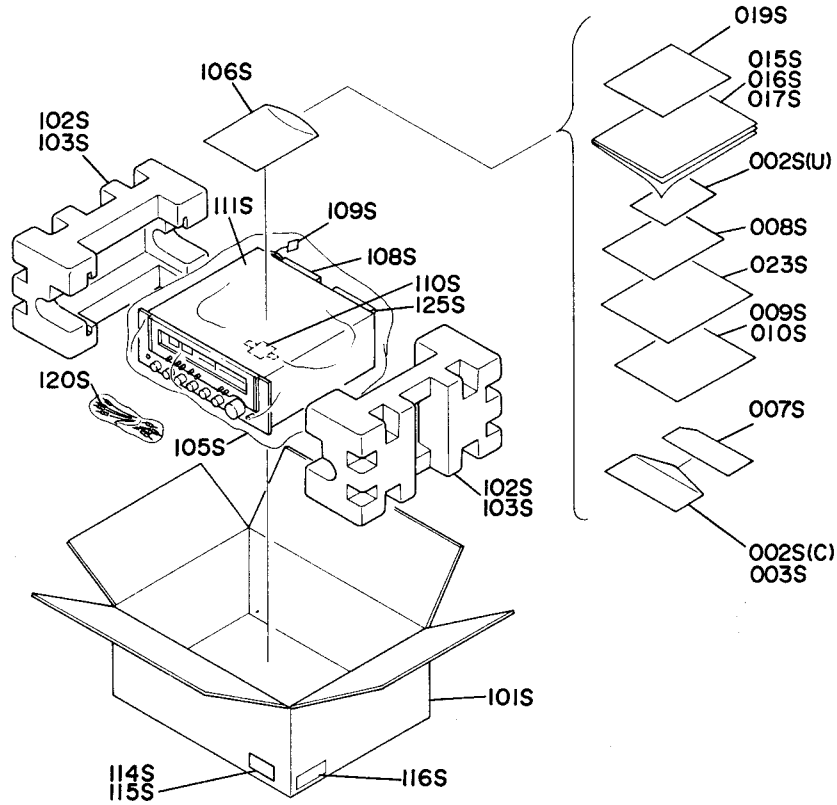

- (U): for U.S.A.
- (C): for Canada
- (N): for Europe

REF. DESIG.	Q.TY			PART NO.	DESCRIPTION
	U	C	N		
002S	1			2225813010	Envelope
002S		1		2918813012	Envelope
003S			1	2818813010	Envelope
007S		1	1	9630000180	Guarantee Card
008S		1		9650000053	S. Station Card
009S	1			2818854024	Guarantee Card
010S		1		2818854042	Guarantee Card
015S	1			2276851012	Instructions
016S		1		2276851310	Instructions (M1530, ONLY)
016S		1		2468851310	Instructions (MR230, ONLY)
017S		1		2276851012	Instructions
019S	1	1		2277851020	Instructions
019S			1	2469851030	Instructions
023S		1		2886851100	Instructions
101S	1	1		2277801010	Packing Case
101S		1		2277801150	Packing Case
101S		1		2469801010	Packing Case (MR230, ONLY)
102S		2		2276809020	Cushion (M1530, ONLY)
102S		2		2276809010	Cushion (MR230, ONLY)
103S	2	2		2276809020	Cushion
103S	2			2276809010	Cushion (MR235, ONLY)
019S	1			2277851122	Instruction (MR225, ONLY)
101S	1			2277801020	Packing Case (MR235, ONLY)

REF. DESIG.	Q.TY			PART NO.	DESCRIPTION
	U	C	N		
105S	1	1	1	9014838380	Polyethy Bag
106S	1	1	1	9013025010	Polyethy Bag
108S	1	1	1	2864804010	Sleeve
109S			1	9560000043	Hang Tag
110S			1	2731821010	Silicagel
111S	1	1	1	2918107130	Sheet
114S	3			9526019010	Serial No. Card
114S		3		9526019020	Serial No. Card
115S			3	9526019060	Serial No. Card
116S		2		9510901020	Label
120S	1	1	1	ZA02000070	EXT. Antenna
125S	1	1	1	2819056010	Buffer
					M1530 (U)(C)(N)
					MR230 (N), ONLY
					MR230 (U), ONLY

6.7 ELECTRICAL PARTS

- (U): for U.S.A.
- (C): for Canada
- (N): for Europe

REF. DESIG.	Q'TY			PART NO.	DESCRIPTION
	U	C	N		
P100	1	1	1	YG22590012	M1530, ONLY
	1	1	1	ZZ22590010	P100-TUNER CIRCUIT BOARD
			1	ZZ22778010	P.W. Board, Tuner P.W. Board Assembly P.W. Board Assembly
P100			1	YG22590012	MR230, ONLY
			1	ZZ24698010	P100-TUNER CIRCUIT BOARD P.W. Board, Tuner P.W. Board Assembly
					P100-CAPACITORS
C101	1	1	1	DD11070370	Ceramic 7pF ±0.5pF
C102	1	1	1	DK16102300	Ceramic 0.001µF ±10%
C104	1	1	1	DK17103300	Ceramic 0.01µF ±20%
C105	1	1	1	DD15180370	Ceramic 18pF ±5%
C106	1	1	1	DD10030370	Ceramic 3pF ±0.5pF
C107	1	1	1	DD10050370	Ceramic 5pF ±0.25pF
C108	1	1	1	DD15301360	Ceramic 300pF ±5%
C109	1	1	1	DK17103300	Ceramic 0.01µF ±20%
C110	1	1	1	DD15200330	Ceramic 20pF ±5%
C111	1	1	1	DD11100300	Ceramic 10pF ±0.5pF
C112	1	1	1	DD15150300	Ceramic 15pF ±5%
C113	1	1	1	DD15150300	Ceramic 15pF ±5%
C114	1	1	1	DK17103300	Ceramic 0.01µF ±20%
C115	1	1	1	DD10020370	Ceramic 2pF ±0.25pF
C116	1	1	1	DK17103300	Ceramic 0.01µF ±20%
C117	1	1	1	DK17103300	Ceramic 0.01µF ±20%
C118	1	1	1	DK17103300	Ceramic 0.01µF ±20%
C119	1	1	1	CT11000080	Trimming 10pF ±0.5pF
C120	1	1	1	CA32400090	Variable C752J
C122	1	1	1	DD11100370	Ceramic 10pF ±0.5pF
C151	1	1	1	DF55361090	Film 360pF ±5%
C152	1	1	1	DD10050370	Ceramic 5pF ±0.25pF
C153	1	1	1	EA10701690	Elect 100µF ±20% 16V
C154	1	1	1	DK18403320	Ceramic 0.04µF +80% -20%
C155	1	1	1	EA33601690	Elect 33µF ±20% 16V
C156	1	1	1	DK18223310	Ceramic 0.022µF +80% -20%
C157	1	1	1	DD15820370	Ceramic 82pF ±5%
C201	1	1	1	DK17103300	Ceramic 0.01µF ±20%
C202	1	1	1	DK17103300	Ceramic 0.01µF ±20%
C203	1	1	1	DK17103300	Ceramic 0.01µF ±20%
C204	1	1	1	DK17103300	Ceramic 0.01µF ±20%
C205	1	1	1	DK18403320	Ceramic 0.04µF +80% -20%
C206	1	1	1	DK18403320	Ceramic 0.04µF +80% -20%
C207	1	1	1	DK18403320	Ceramic 0.04µF +80% -20%
C208	1	1	1	DK17103300	Ceramic 0.01µF ±20%
C209	1	1	1	DK17103300	Ceramic 0.01µF ±20%
C210	1	1	1	DD15201360	Ceramic 200pF ±5%
C211	1	1	1	DK17103300	Ceramic 0.01µF ±20%
C212	1	1	1	DK18403320	Ceramic 0.04µF +80% -20%
C213	1	1	1	DK17103300	Ceramic 0.01µF ±20%
C214	1	1	1	DK17103300	Ceramic 0.01µF ±20%
C215	1	1	1	EA33502590	Elect 3.3µF ±20% 25V
C216	1	1	1	DK18223310	Ceramic 0.022µF +80% -20%
C217	1	1	1	EA47503590	Elect 4.7µF ±20% 35V
C218	1	1	1	EA22701690	Elect 220µF ±20% 16V
C219	1	1	1	DK17103300	Ceramic 0.01µF ±20%
C220	1	1	1	DK18104020	Ceramic 0.01µF ±20%

REF. DESIG.	Q'TY			PART NO.	DESCRIPTION
	U	C	N		
C221	1	1	1	DK17103300	Ceramic 0.01µF ±20%
C222	1	1	1	EA10505090	Elect 1µF ±20% 50V
C223	1	1	1	EA47405090	Elect 0.047µF ±20% 50V
C224	1	1	1	EA10601690	Elect 10µF ±20% 16V
C225	1	1	1	DF15182300	Film 1800pF ±5%
C226	1	1	1	EA10601690	Elect 10µF ±20% 16V
C227	1	1	1	EA10505090	Elect 1µF ±20% 50V
C228	1	1	1	DK18403320	Ceramic 0.04µF +80% -20%
C229	1	1	1	DF55102090	Film 1000pF ±5%
C230	1	1	1	DK17103300	Ceramic 0.01µF ±20%
C231	1	1	1	EA10601690	Elect 10µF ±20% 16V
C233	1	1	1	DK17103300	Ceramic 0.01µF ±20%
C234	1	1	1	DK17103300	Ceramic 0.01µF ±20%
C235	1	1	1	EA22701690	Elect 220µF ±20% 16V
C301	1	1	1	EE10505050	Elect 1µF ±20% 50V
C302	1	1	1	EE10505050	Elect 1µF ±20% 50V
C303	1	1	1	DF15332300	Film 0.0033µF ±5%
C304	1	1	1	DF15332300	Film 0.0033µF ±5%
C305	1	1	1	EA22502590	Elect 2.2µF ±20% 25V
C306	1	1	1	EA22502590	Elect 2.2µF ±20% 25V
C307	1	1	1	EE47502590	Elect 4.7µF ±20% 25V
C308	1	1	1	EE47502590	Elect 4.7µF ±20% 25V
C309	1	1	1	EA10701690	Elect 100µF ±20% 16V
C311	1	1	1	EE10505050	Elect 1µF ±20% 50V
C312	1	1	1	EE10405050	Elect 0.1µF ±20% 50V
C313	1	1	1	EA10505090	Elect 1µF ±20% 50V
C314	1	1	1	EA22601690	Elect 22µF ±20% 16V
C315	1	1	1	EA10601690	Elect 10µF ±20% 16V
					P100-RESISTORS
					(All Resistors are ±5% and ¼W)
R101	1	1	1	GD05105140	1MΩ
R102	1	1	1	GD05101140	100Ω
R103	1	1	1	GD05101140	100Ω
R104	1	1	1	GD05472140	4.7KΩ
R105	1	1	1	GD05223140	22KΩ
R106	1	1	1	GD05102140	1KΩ
R107	1	1	1	GD05103140	10KΩ
R108	1	1	1	GD05103140	10KΩ
R109	1	1	1	GD05152140	1.5KΩ
R110	1	1	1	GD05101140	100Ω
R111	1	1	1	GD05273140	27KΩ
R112	1	1	1	GG05101140	100Ω
R113	1	1	1	GD05221140	220Ω
R114	1	1	1	GD05104140	100KΩ
R151	1	1	1	GD05202140	2KΩ
R201	1	1	1	GD05151140	150Ω
R202	1	1	1	GD05272140	2.7KΩ
R203	1	1	1	GD05153140	15KΩ
R204	1	1	1	GD05471140	470Ω
R205	1	1	1	GD05331140	330Ω
R206	1	1	1	GD05331140	330Ω
R207	1	1	1	GD05272140	2.7KΩ
R208	1	1	1	GD05153140	15KΩ
R209	1	1	1	GD05471140	470Ω
R210	1	1	1	GD05331140	330Ω
R211	1	1	1	GD05331140	330Ω
R212	1	1	1	GD05151140	150Ω
R213	1	1	1	GD05472140	4.7KΩ
R214	1	1	1	GD05103140	10KΩ
R215	1	1	1	GD05102140	1KΩ

- (U): for U.S.A.
- (C): for Canada
- (N): for Europe

REF. DESIG.	Q'TY			PART NO.	DESCRIPTION
	U	C	N		
R216	1	1	1	GD05202140	2K Ω
R217	1	1	1	GD05563140	56K Ω
R218	1	1	1	GD05333140	33K Ω
R219	1	1	1	GD05224140	220K Ω
R220	1	1	1	GD05470140	47 Ω
R221	1	1	1	GD05470140	47 Ω
R222	1	1	1	GD05221140	220 Ω
R223	1	1	1	GD05391140	390 Ω
R224	1	1	1	GD05562140	5.6K Ω
R225	1	1	1	GD05332140	3.3K Ω
R226	1	1	1	GD05823140	82K Ω
R227	1	1	1	GD05333140	33K Ω
R228	1	1	1	RA02030060	Trimming 20K Ω
R229	1	1	1	GD05472140	4.7K Ω
R230	1	1	1	GD05822140	8.2K Ω
R231	1	1	1	GD05391140	390 Ω
R232	1	1	1	RA03020030	Trimming 3K Ω (B)
R233	1	1	1	RA05020160	Trimming 5K Ω
R235	1	1	1	GD05473140	47K Ω
R236	1	1	1	GD05151140	150 Ω
R237	1	1	1	GD05561140	560 Ω
R238	1	1	1	GD05563140	56K Ω
R239	1	1	1	GD05104140	100K Ω
R240	1	1	1	GD05104140	100K Ω
R241	1	1	1	GD05152140	1.5K Ω
R242	1	1	1	GD05473140	47K Ω
R243	1	1	1	GD05104140	100K Ω
R244	1	1	1	GD05153140	15K Ω
R245	1	1	1	GD05153140	15K Ω
R246	1	1	1	GD05104140	100K Ω
R248	1	1	1	GD05222140	2.2K Ω
R250	1	1	1	GD05123140	12K Ω
R251	1	1	1	GD05244140	240K Ω
R252	1	1	1	GD05104140	100K Ω
R255	1	1	1	GD05100140	10 Ω
R256	1	1	1	GD05153140	15K Ω
R257	1	1	1	GD05103140	10K Ω
R258	1	1	1	GD05271140	270 Ω
R301	1	1	1	GD05472140	2.7K Ω
R302	1	1	1	GD05472140	2.7K Ω
R303	1	1	1	GD05472140	2.7K Ω
R304	1	1	1	GD05472140	2.7K Ω
R305	1	1	1	GD05303140	30K Ω
R305	1	1	1	GD05183140	18K Ω
R306	1	1	1	GD05303140	30K Ω
R306	1	1	1	GD05183140	18K Ω
R307	1	1	1	GD05105140	1M Ω
R308	1	1	1	GD05105140	1M Ω
R309	1	1	1	GD05204140	200K Ω
R309	1	1	1	GD05154140	150K Ω
R310	1	1	1	GD05204140	200K Ω
R310	1	1	1	GD05154140	150K Ω
R311	1	1	1	GD05472140	4.7K Ω
R312	1	1	1	GD05472140	4.7K Ω
R313	1	1	1	GD05301140	300 Ω
R313	1	1	1	GD05241140	240 Ω
R314	1	1	1	GD05301140	300 Ω
R314	1	1	1	GD05241140	240 Ω
R315	1	1	1	GD05102140	1K Ω
R316	1	1	1	RA01030260	Trimming 10K Ω

REF. DESIG.	Q'TY			PART NO.	DESCRIPTION
	U	C	N		
R317	1	1	1	GD05473140	47K Ω
R318	1	1	1	GD05473140	47K Ω
R319	1	1	1	GD05101140	100 Ω
R320	1	1	1	GD05101140	100 Ω
R321	1	1	1	GD05101140	100 Ω
R325	1	1	1	GD05562140	5.6K Ω
R326	1	1	1	RA04720050	Trimming 4.7K Ω (B)
R327	1	1	1	GD05103140	10K Ω
R328	1	1	1	GD05102140	1K Ω
R329	1	1	1	GD05102140	1K Ω
R330	1	1	1	GD05103140	10K Ω
R331	1	1	1	GD05101140	100 Ω
R332	1	1	1	GD05103140	10K Ω
R333	1	1	1	GD05104140	100K Ω
R334	1	1	1	GD05104140	100K Ω
Q101	1	1	1	HF400451B0	F.E.T. 3SK45 (B)
Q102	1	1	1	HT305352B0	Transistor 2SC535 (B or C)
Q103	1	1	1	HT308291C0	Transistor 2SC829 (C)
Q151	1	1	1	HD20001210	Diode 1S2473C
Q152	1	1	1	HD20001210	Diode 1S2473C
Q201	1	1	1	HT308291C0	Transistor 2SC829 (C)
Q202	1	1	1	HT308291C0	Transistor 2SC829 (C)
Q203	1	1	1	HT308291C0	Transistor 2SC829 (C)
Q204	1	1	1	HD10003020	Diode 20A90M
Q205	1	1	1	HD10003020	Diode 20A90M
Q206	1	1	1	HC10009020	IC AN7000
Q207	1	1	1	HT308291C0	Transistor 2SC829 (C)
Q208	1	1	1	HD10003020	Diode 20A90M
Q209	1	1	1	HD20001210	Diode 1S2473C
Q210	1	1	1	HT308281D0	Transistor 2SC828 (S)
Q211	1	1	1	HT308281D0	Transistor 2SC828 (S)
Q212	1	1	1	HT107222A0	Transistor 2SA722 (S or T)
Q214	1	1	1	HD10003020	Diode 20A90M
Q301	1	1	1	HT308281D0	Transistor 2SC828 (S)
Q302	1	1	1	HT308281D0	Transistor 2SC828 (S)
Q310	1	1	1	HD10003020	Diode 20A90M
Q311	1	1	1	HT107222A0	Transistor 2SA722 (S or T)
F151	1	1	1	FF10045180	Ceramic Filter AM
F201	1	1	1	FF11070050	Ceramic Filter FM SFE10.7MD1
F202	1	1	1	FF11070050	Ceramic Filter FM SFE10.7MD1
F203	1	1	1	FF11070050	Ceramic Filter FM SFE10.7MD1
L101	1	1	1	LA12028040	Ant. Coil FM
L102	1	1	1	LA12028050	Ant. Coil FM
L103	1	1	1	LO12036010	OSC Coil FM
L104	1	1	1	LI10016010	I.F.T. FM
L105	1	1	1	LC13320020	Choke Coil 3.3 μ H
L106	1	1	1	LC17510010	Choke Coil 0.75 μ H
L151	1	1	1	LC13320020	Choke Coil 3.3 μ H
L152	1	1	1	LC13320020	Choke Coil 3.3 μ H
L153	1	1	1	LO10013150	OSC Coil AM
L154	1	1	1	LI10013200	I.F.T. AM

• (U): for U.S.A.
 • (C): for Canada
 • (N): for Europe

REF. DESIG.	Q'TY			PART NO.	DESCRIPTION
	U	C	N		
L201	1	1	1	LI14016240	I.F.T. FM Det
L202	1	1	1	LC11830020	Choke Coil 18μH
L203	1	1	1	LC23960020	Choke Coil 39mH
L204	1	1	1	LC12250030	Choke Coil 2200μH
L205	1	1	1	LC11030020	Choke Coil 10μH
L301	1	1	1	LS20013010	M.P.X. Coil
L302	1	1	1	LS20013010	M.P.X. Coil
P400-PHONO CIRCUIT BOARD					
P400	1	1	1	YG22780010	P.W. Board, Phono (M1530, ONLY)
	1	1	1	ZZ22780010	P.W. Board Assembly (MR230, ONLY)
			1	ZZ24696010	P.W. Board Assembly
P400-CAPACITORS					
CV01	1	1	1	DK17103300	Ceramic 0.01μF ±20%
CV02	1	1	1	DK17103300	Ceramic 0.01μF ±20%
C401	1	1	1	EE33502550	Elect 3.3μF 25V
C402	1	1	1	EE33502550	Elect 3.3μF 25V
C403	1	1	1	DD15470360	Ceramic 47pF ±5%
C404	1	1	1	DD15470360	Ceramic 47pF ±5%
C405	1	1	1	EA10701090	Elect 100μF 10V
C406	1	1	1	EA10701090	Elect 100μF 10V
C407	1	1	1	DK16221300	Ceramic 220pF ±10%
C408	1	1	1	DK16221300	Ceramic 220pF ±10%
C409	1	1	1	DF15123300	Film 0.012μF ±5%
C410	1	1	1	DF15123300	Film 0.012μF ±5%
C411	1	1	1	DF15332300	Film 3300pF ±5%
C412	1	1	1	DF15332300	Film 3300pF ±5%
C413	1	1	1	EA10505090	Elect 1μF 50V
C414	1	1	1	EA10703590	Elect 100μF 35V
C415	1	1	1	EA10505090	Elect 1μF 50V
C416	1	1	1	EA10505090	Elect 1μF 50V
C417	1	1	1	DD15220360	Ceramic 22pF ±5%
C418	1	1	1	DD15220360	Ceramic 22pF ±5%
C419	1	1	1	DK16332300	Ceramic 0.0033μF ±10%
C420	1	1	1	DK16332300	Ceramic 0.0033μF ±10%
CM01	1	1	1	EA10703590	Elect 100μF 35V
CM02	1	1	1	EA10701090	Elect 100μF 10V
CM03	1	1	1	EA33605090	Elect 3.3μF 50V
CM04	1	1	1	DK17103300	Ceramic 0.01μF ±20%
P400-RESISTORS (All Resistors are ±5% and ¼W)					
RV01	1	1	1	GA05561010	560Ω 1W
RV02	1	1	1	GD05152140	1.5KΩ
RV03	1	1	1	GD05272140	2.7KΩ
R401	1	1	1	GD05623140	62KΩ
R402	1	1	1	GD05623140	62KΩ
R403	1	1	1	GD05182140	1.8KΩ
R404	1	1	1	GD05182140	1.8KΩ
R405	1	1	1	GD05184140	180KΩ
R406	1	1	1	GD05184140	180KΩ
R407	1	1	1	GD05471140	470Ω
R408	1	1	1	GD05471140	470Ω
R409	1	1	1	GD05274140	270KΩ
R410	1	1	1	GD05274140	270KΩ
R411	1	1	1	GD05274140	270KΩ
R412	1	1	1	GD05274140	270KΩ
R413	1	1	1	GD05223140	22KΩ
R414	1	1	1	GD05223140	22KΩ
R415	1	1	1	GD05681140	680Ω
R416	1	1	1	GD05681140	680Ω
R417	1	1	1	GD05223140	22KΩ

REF. DESIG	Q'TY			PART NO.	DESCRIPTION
	U	C	N		
R418	1	1	1	GD05223140	22KΩ
R419	1	1	1	GD05224140	220KΩ
R420	1	1	1	GD05224140	220KΩ
R421	1	1	1	GD05151140	150Ω
R422	1	1	1	GD05151140	150Ω
R423	1	1	1	GD05184140	180KΩ
R424	1	1	1	GG05181140	180Ω
RM01	1	1	1	GD05333140	33KΩ
RM02	1	1	1	GD05103140	10KΩ
RM03	1	1	1	GD05474140	470KΩ
RM04	1	1	1	GD05100140	10Ω
RM05	1	1	1	GD05273140	27KΩ
RM06	1	1	1	GD05272140	2.7KΩ
RM07	1	1	1	GD05153140	15KΩ
P400-SEMICONDUCTORS					
Q401	1	1	1	HC10012060	IC μPC1024H
Q402	1	1	1	HC10012060	IC μPC1024H
QM01	1	1	1	HD20011050	Diode 1S1555
QM02	1	1	1	HT309452A0	Transistor 2SC945 (Q or R)
QM03	1	1	1	HT309452A0	Transistor 2SC945 (Q or R)
QM04	1	1	1	HT309452A0	Transistor 2SC945 (Q or R)
P400-MISCELLANEOUS					
JV01	1	1	1	YT02040260	Terminal, Phono Aux
JV02	1	1	1	YT02040260	Terminal, Tape 1
SV01	1	1	1	SR10060180	Rotary Switch
P700-MAIN AMP./POWER SUPPLY CIRCUIT BOARD					
P700	1	1	1	YG22770010	P.W. Board, Main Amp/Power Supply
	1	1		ZZ22770010	P.W. Board Assembly M1530, ONLY
			1	ZZ22778110	P.W. Board Assembly MR230, ONLY
			1	ZZ24695010	P.W. Board Assembly
P700-CAPACITORS					
C701	1	1	1	DD15201360	Ceramic 200pF ±5%
C702	1	1	1	DD15201360	Ceramic 200pF ±5%
C703	1	1	1	EE22502550	Elect 2.2μF 25V
C704	1	1	1	EE22502550	Elect 2.2μF 25V
C705	1	1	1	EE47600650	Elect 47μF 6.3V
C706	1	1	1	EE47600650	Elect 47μF 6.3V
C711	1	1	1	DD10050360	Ceramic 5pF ±0.25pF
C712	1	1	1	DD10050360	Ceramic 5pF ±0.25pF
C713	1	1	1	DF17104300	Film 0.1μF ±20%
C714	1	1	1	DF17104300	Film 0.1μF ±20%
C719	1	1	1	DK16102300	Ceramic 0.001μF ±10%
C720	1	1	1	DK16102300	Ceramic 0.001μF ±10%
C723	1	1	1	DF17104570	Film 0.1μF ±20%
C724	1	1	1	DF17104570	Film 0.1μF ±20%
C729	1	1	1	EA10705090	Elect 100μF 50V
C730	1	1	1	EA10705090	Elect 100μF 50V
C731	1	1	1	DD15500500	Ceramic 50pF ±5% 200V
C732	1	1	1	DD15500500	Ceramic 50pF ±5% 200V
C733	1	1	1	DD15500500	Ceramic 50pF ±5% 200V
C734	1	1	1	DD15500500	Ceramic 50pF ±5% 200V

- (U): for U.S.A.
- (C): for Canada
- (N): for Europe

REF. DESIG.	Q'TY			PART NO.	DESCRIPTION
	U	C	N		
C735	1	1	1	DK17103300	Ceramic 0.01μF ±20%
C801	1	1	1	EB10904210	Elect 10000μF 42V
C802	1	1	1	EB10904210	Elect 10000μF 42V
C803	1	1	1	DK18103510	Ceramic 0.01μF +80%—0
C804	1	1	1	DK18103510	Ceramic 0.01μF +80%—0
C805	1	1	1	EA47706310	Elect 470μF 63V
C806	1	1	1	EA22705090	Elect 220μF 50V
C807	1	1	1	DK17103300	Ceramic 0.01μF ±20%
C808	1	1	1	DK17103300	Ceramic 0.01μF ±20%
C809	1	1	1	EA10603590	Elect 10μF 35V
C810	1	1	1	EA10703590	Elect 100μF 50V
C811	1	1	1	EA47701690	Elect 470μF 16V
C816	1	1	1	DK17103300	Ceramic 0.01μF ±20%
C818	1	1	1	EQ10601610	Elect 10μF 16V
C819	1	1	1	DK18103510	Ceramic 0.01μF +80%—0
C820	1	1	1	DK18103510	Ceramic 0.01μF +80%—0
P700-RESISTORS (All Resistors are ±5% and ¼W)					
R701	1	1	1	GD05102140	1KΩ
R702	1	1	1	GD05102140	1KΩ
R703	1	1	1	GD05104140	100KΩ
R704	1	1	1	GD05104140	100KΩ
R705	1	1	1	GD05681140	680Ω
R706	1	1	1	GD05681140	680Ω
R707	1	1	1	GD05914140	910KΩ
R708	1	1	1	GD05914140	910KΩ
R709	1	1	1	GD05105140	1MΩ
R710	1	1	1	GD05105140	1MΩ
R711	1	1	1	GD05222140	2.2KΩ
R712	1	1	1	GD05222140	2.2KΩ
R713	1	1	1	GD05222140	2.2KΩ
R714	1	1	1	GD05222140	2.2KΩ
R717	1	1	1	RA01020160	Trimming 1KΩ (B)
R718	1	1	1	RA01020160	Trimming 1KΩ (B)
R721	1	1	1	GD05104140	100KΩ
R722	1	1	1	GD05104140	100KΩ
R723	1	1	1	GD05103140	10KΩ
R724	1	1	1	GD05103140	10KΩ
R725	1	1	1	GD05912140	9.1KΩ
R726	1	1	1	GD05912140	9.1KΩ
R727	1	1	1	GD05154140	150KΩ
R728	1	1	1	GD05154140	150KΩ
R729	1	1	1	GD05154140	150KΩ
R730	1	1	1	GD05154140	150KΩ
R733	1	1	1	GG05102140	1KΩ
R734	1	1	1	GG05102140	1KΩ
R735	1	1	1	GG05102140	1KΩ
R736	1	1	1	GG05102140	1KΩ
R741	1	1	1	GN10472030	0.47Ω 3W
R742	1	1	1	GN10472030	0.47Ω 3W
R743	1	1	1	GN10472030	0.47Ω 3W
R744	1	1	1	GN10472030	0.47Ω 3W
R745	1	1	1	GA05100020	10Ω 2W
R746	1	1	1	GA05100020	10Ω 2W
R747	1	1	1	RC10022120	2.2Ω ±10% ¼W
R748	1	1	1	RC10022120	2.2Ω ±10% ¼W
R749	1	1	1	GA05331020	330Ω 2W
R750	1	1	1	GA05331020	330Ω 2W

REF. DESIG.	Q'TY			PART NO.	DESCRIPTION
	U	C	N		
R751	1	1	1	GG05151120	150Ω ¼W
R752	1	1	1	GG05151120	150Ω ¼W
R753	1	1	1	GG05101140	100Ω
R754	1	1	1	GG05101140	100Ω
R755	1	1	1	GD05683140	68KΩ
R756	1	1	1	GD05683140	68KΩ
R757	1	1	1	GD05752140	7.5KΩ
R758	1	1	1	GD05752140	7.5KΩ
R759	1	1	1	GD05102140	1KΩ
R760	1	1	1	GD05102140	1KΩ
R761	1	1	1	GG05330140	33Ω
R762	1	1	1	GG05330140	33Ω
R763	1	1	1	GG05330140	33Ω
R764	1	1	1	GG05330140	33Ω
R765	1	1	1	GD05122140	1.2KΩ
R766	1	1	1	GD05122140	1.2KΩ
R801	1	1	1	GP05151030	150Ω 3W
R802	1	1	1	GG05152140	1.5KΩ
R803	1	1	1	GG05102140	1KΩ
R804	1	1	1	GD05103140	10KΩ
R805	1	1	1	GD05682140	6.8KΩ
R806	1	1	1	GD05242140	2.4KΩ
P700-SEMICONDUCTORS					
Q701	1	1	1	HC10003360	IC LM391-80
Q702	1	1	1	HC10003360	IC LM391-80
Q703	1	1	1	HT404152B0	Transistor 2SD415 (Q or R)
Q704	1	1	1	HT404152B0	Transistor 2SD415 (Q or R)
Q705	1	1	1	HT205492B0	Transistor 2SB549 (Q or R)
Q706	1	1	1	HT205492B0	Transistor 2SB549 (Q or R)
Q711	1	1	1	HD20005010	Diode W06B
Q712	1	1	1	HD20005010	Diode W06B
Q713	1	1	1	HD20005010	Diode W06B
Q714	1	1	1	HD20005010	Diode W06B
Q719	1	1	1	HD20003210	Diode 1S2471
Q720	1	1	1	HD20003210	Diode 1S2471
Q721	1	1	1	HD20003210	Diode 1S2471
Q722	1	1	1	HD20003210	Diode 1S2471
Q801	1	1	1	HE10001030	Diode DS133B
Q802	1	1	1	HE10001030	Diode DS133B
Q804	1	1	1	HD20022100	Diode 10E1
Q805	1	1	1	HT403131Q0	Transistor 2SD313E
Q806	1	1	1	HT309452A0	Transistor 2SC945 (Q or R)
Q807	1	1	1	HD30022090	Zener BZ-1201W
Q808	1	1	1	HD20010290	Diode S3V-20
Q809	1	1	1	HD20010290	Diode S3V-20
Q810	1	1	1	HD20010290	Diode S3V-20
Q811	1	1	1	HD20010290	Diode S3V-20
P700-MISCELLANEOUS					
J731	1	1	1	YJ06001870	Jack
J732	1	1	1	YJ06001870	Jack
J733	1	1	1	YJ06001870	Jack
J734	1	1	1	YJ06001870	Jack
L701	1	1	1	LL23915120	Choke Coil
L702	1	1	1	LL23915120	Choke Coil
F701	1	1	1	FS10400050	Fuse 4A 250V
F701	1	1	1	FS10400800	Fuse 4AT 250V
F702	1	1	1	FS10400050	Fuse 4A 250V
F702	1	1	1	FS10400800	Fuse 4AT 250V

• (U): for U.S.A.
 • (C): for Canada
 • (N): for Europe

REF. DESIG.	Q'TY			PART NO.	DESCRIPTION
	U	C	N		
J701 ? J704 J701 ? J704	4	4		YJ08000170	Jack, Fuse Holder
			4	YJ08000270	Jack, Fuse Holder
PC00	1	1	1	YH22760210	PC00-ANTENNA CIRCUIT BOARD P.W. Board, Antenna
	1	1	1	ZZ22760210	P.W. Board Assembly
JC01	1	1	1	YT01040182	Terminal
LC01	1	1	1	LB30075260	Balun Coil
PE00	1	1	1	YK22780210	PE00-TONE AMP. CIRCUIT BOARD P.W. Board, Tone Amp.
	1	1	1	ZZ22780210	P.W. Board Assembly
CE01	1	1	1	EE22405050	PE00-CAPACITORS Elect 0.22 μ F 50V
CE02	1	1	1	EE22405050	Elect 0.22 μ F 50V
CE03	1	1	1	DD15151370	Ceramic 150pF \pm 5%
CE04	1	1	1	DD15151370	Ceramic 150pF \pm 5%
CE05	1	1	1	EE47502550	Elect 4.7 μ F 25V
CE06	1	1	1	EE47502550	Elect 4.7 μ F 25V
CE09	1	1	1	DD15101370	Ceramic 100pF \pm 5%
CE10	1	1	1	DD15101370	Ceramic 100pF \pm 5%
CE11	1	1	1	DF16222300	Film 2200pF \pm 10%
CE12	1	1	1	DF16222300	Film 2200pF \pm 10%
CE13	1	1	1	DF16472300	Film 4700pF \pm 10%
CE14	1	1	1	DF16472300	Film 4700pF \pm 10%
CE15	1	1	1	DF16223300	Film 0.022 μ F \pm 10%
CE16	1	1	1	DF16223300	Film 0.022 μ F \pm 10%
CE17	1	1	1	DF16223300	Film 0.022 μ F \pm 10%
CE18	1	1	1	DF16223300	Film 0.022 μ F \pm 10%
CE19	1	1	1	DF16822300	Film 8200pF \pm 10%
CE20	1	1	1	DF16822300	Film 8200pF \pm 10%
CE21	1	1	1	EE10505050	Elect 1 μ F 50V
CE22	1	1	1	EE10505050	Elect 1 μ F 50V
CE23	1	1	1	DD11100370	Ceramic 10pF \pm 0.5pF
CE24	1	1	1	DD11100370	Ceramic 10pF \pm 0.5pF
CE25	1	1	1	EE33505050	Elect 3.3 μ F 50V
CE26	1	1	1	EE33505050	Elect 3.3 μ F 50V
CE27	1	1	1	EE10505050	Elect 1 μ F 50V
CE28	1	1	1	EE10505050	Elect 1 μ F 50V
CE31	1	1	1	EA22703590	Elect 220 μ F 35V
RE03	1	1	1	RK02040072	PE00-RESISTORS (All Resistors are \pm 5% and $\frac{1}{4}$ W) Variable 200K Ω (B)
RE04	1	1	1	RM01040200	Variable 100K Ω (B)
RE05	1	1	1	GD05474140	470K Ω
RE06	1	1	1	GD05474140	470K Ω
RE07	1	1	1	GD05102140	1K Ω
RE08	1	1	1	GD05102140	1K Ω
RE09	1	1	1	GD05105140	1M Ω
RE10	1	1	1	GD05105140	1M Ω
RE11	1	1	1	GD05103140	10K Ω
RE12	1	1	1	GD05104140	100K Ω

REF. DESIG.	Q'TY			PART NO.	DESCRIPTION
	U	C	N		
RE13	1	1	1	GD05102140	1K Ω
RE14	1	1	1	GD05102140	1K Ω
RE15	1	1	1	GD05183140	18K Ω
RE16	1	1	1	GD05183140	18K Ω
RE17	1	1	1	GD05822140	8.2K Ω
RE18	1	1	1	GD05822140	8.2K Ω
RE19	1	1	1	GD05474140	470K Ω
RE20	1	1	1	GD05474140	470K Ω
RE21	1	1	1	75061001P0	Jumper
RE22	1	1	1	75061001P0	Jumper
RE23	1	1	1	GD05682140	6.8K Ω
RE24	1	1	1	GD05682140	6.8K Ω
RE25	1	1	1	GD05113140	11K Ω
RE26	1	1	1	GD05113140	11K Ω
RE27	1	1	1	GD05562140	5.6K Ω
RE28	1	1	1	GD05562140	5.6K Ω
RE29	1	1	1	GD05752140	7.5K Ω
RE30	1	1	1	GD05752140	7.5K Ω
RE31	1	1	1	GD05273140	27K Ω
RE32	1	1	1	GD05273140	27K Ω
RE33	1	1	1	GD05123140	12K Ω
RE34	1	1	1	GD05123140	12K Ω
RE35	1	1	1	GD05153140	15K Ω
RE36	1	1	1	GD05153140	15K Ω
RE37	1	1	1	GD05274140	270K Ω
RE38	1	1	1	GD05274140	270K Ω
RE39	1	1	1	GD05273140	27K Ω
RE40	1	1	1	GD05273140	27K Ω
RE41	1	1	1	GD05683140	68K Ω
RE42	1	1	1	GD05683140	68K Ω
RE43	1	1	1	GD05225140	2.2M Ω
RE44	1	1	1	GD05225140	2.2M Ω
RE45	1	1	1	GD05181140	180 Ω
RE46	1	1	1	GD05181140	180 Ω
RE47	1	1	1	GD05123140	12K Ω
RE48	1	1	1	GD05123140	12K Ω
RE49	1	1	1	GD05103140	10K Ω
RE50	1	1	1	GD05103140	10K Ω
RE51	1	1	1	GD05473140	47K Ω
RE52	1	1	1	GD05473140	47K Ω
RE53	1	1	1	RM01040210	Variable 100K Ω (B)
RE54	1	1	1	RM01040210	Variable 100K Ω (B)
RE55	1	1	1	RM01040210	Variable 100K Ω (B)
RE56	1	1	1	GG05221140	220 Ω
RE57	1	1	1	GD05274140	270K Ω
RE58	1	1	1	GD05274140	270K Ω
QE01	1	1	1	HT316812A0	PE00-SEMICONDUCTORS Transistor 2SC1681 (GR, BL)
QE02	1	1	1	HT316812A0	Transistor 2SC1681 (GR, BL)
QE03	1	1	1	HT108412A0	Transistor 2SA841 (GR, BL)
QE04	1	1	1	HT108412A0	Transistor 2SA841 (GR, BL)
QE05	1	1	1	HT316812A0	Transistor 2SC1681 (GR, BL)
QE06	1	1	1	HT316812A0	Transistor 2SC1681 (GR, BL)
QE07	1	1	1	HT108412A0	Transistor 2SA841 (GR, BL)
QE08	1	1	1	HT108412A0	Transistor 2SA841 (GR, BL)
JE04	1	1	1	YU05130010	PE00-MISCELLANEOUS Jumper Lead (5P)

- (U): for U.S.A.
- (C): for Canada
- (N): for Europe

REF. DESIG.	Q'TY			PART NO.	DESCRIPTION
	U	C	N		
PN01	1	1	1	YH22771210	PN01-POWER TRANSISTOR CIRCUIT BOARD P.W. Board, Power Transistor P.W. Board Assembly
	1	1	1	ZZ22771210	
PN01-RESISTORS (All Resistors are ±5% and ¼W)					
RN01	1	1	1	GG05101140	100Ω
RN02	1	1	1	GG05101140	100Ω
RN03	1	1	1	GG05101140	100Ω
RN04	1	1	1	GG05101140	100Ω
RN05	1	1	1	75061001P0	Jumper
RN06	1	1	1	75061001P0	Jumper
RN07	1	1	1	GG05330140	33Ω
RN08	1	1	1	GG05330140	33Ω
PN01-SEMICONDUCTORS					
QN01	1	1	1	HT407182A0	Transistor 2SD718 (R or Q)
QN02	1	1	1	HT407182A0	Transistor 2SD718 (R or Q)
QN03	1	1	1	HT206882A0	Transistor 2SB688 (R or Q)
QN04	1	1	1	HT206882A0	Transistor 2SB688 (R or Q)
QN05	1	1	1	HV00008120	Varistor MV-1Y
QN06	1	1	1	HV00008120	Varistor MV-1Y
PN01-PLUG					
JN01	4	4	4	YP06001600	Plug
JN04					
PP01-FUSE CIRCUIT BOARD					
PP01	1			YF22770020	P.W. Board, Fuse
	1			ZZ22771020	P.W. Board Assembly
M1530, ONLY					
PP01	1			YF22770010	P.W. Board, Fuse
	1			ZZ22778210	P.W. Board Assembly
MR230, ONLY					
PP01	1			YF22760032	P.W. Board, Fuse
	1			ZZ22760030	P.W. Board Assembly
FP01-FUSE					
FP01	1			FS10150900	Fuse 1.5A 125V
FP02	1			FS10100900	Fuse 1A 125V
FP03	1			FS10600900	Fuse 6A 125V
FP04	1			FS10600900	Fuse 6A 125V
FP01	1			FS10160800	Fuse 1.6AT 250V
FP02	1			FS10100800	Fuse 1AT 250V
FP03	1			FS10250800	Fuse 2.5AT 250V
FP04	1			FS10250800	Fuse 2.5AT 250V
JP01-JACK					
JP01	8	8		YJ08000200	Jack, Fuse Holder
JP08					
JP09	1			YP06001560	Plug

REF. DESIG.	Q'TY			PART NO.	DESCRIPTION
	U	C	N		
PS00	1	1	1	YK22760410	PS00-SWITCH CIRCUIT BOARD P.W. Board, Switch P.W. Board Assembly P.W. Board Assembly
	1	1	1	ZZ22770410	
	1	1	1	ZZ22778410	
PS00-CAPACITORS					
CS01	1	1	1	DD15561370	Ceramic 560pF ±5%
CS02	1	1	1	DD15561370	Ceramic 560pF ±5%
CS03	1	1	1	DF17683300	Film 0.068μF ±20%
CS04	1	1	1	DF17683300	Film 0.068μF ±20%
CS05	1	1	1	DF15222300	Film 0.0022μF ±5%
CS06	1	1	1	DF15222300	Film 0.0022μF ±5%
CS07	1	1	1	DF17104300	Film 0.1μF ±20%
CS08	1	1	1	DF17104300	Film 0.1μF ±20%
CS09	1	1	1	EE33405040	Elect 0.33μF 50V
CS10	1	1	1	EE33405040	Elect 0.33μF 50V
CS11	1	1	1	DF15472300	Film 0.0047μF ±5%
CS12	1	1	1	DF15472300	Film 0.0047μF ±5%
PS00-RESISTORS (All Resistors are ±5% and ¼W)					
RS01	1	1	1	GD05332140	3.3KΩ
RS02	1	1	1	GD05332140	3.3KΩ
RS03	1	1	1	GD05563140	56KΩ
RS04	1	1	1	GD05563140	56KΩ
RS05	1	1	1	GD05622140	6.2KΩ
RS06	1	1	1	GD05622140	6.2KΩ
RS07	1	1	1	GD05103140	10KΩ
RS08	1	1	1	GD05103140	10KΩ
RS11	1	1	1	GD05432140	4.3KΩ
RS12	1	1	1	GD05432140	4.3KΩ
RS13	1	1	1	GD05393140	39KΩ
RS14	1	1	1	GD05393140	39KΩ
RS15	1	1	1	GD05221140	220Ω
RS16	1	1	1	GD05332140	3.3KΩ
RS17	1	1	1	GD05332140	3.3KΩ
PS00-SWITCH					
SS01	1	1	1	SP02050040	Push Switch
PY01-LED CIRCUIT BOARD					
PY01	1	1	1	YH22771220	P.W. Board, LED
	1	1	1	ZZ22771220	P.W. Board Assembly
QY01	1	1	1	HI10009020	L.E.D. LN26RP Stereo Ind.
M1530 (U)(C)(N) MR230 (N), ONLY					

(W01-99)	Assembly and Wiring
(T01-99)	Adjustment
(X01-00)	Correction

7. TECHNICAL SPECIFICATIONS

[U.S.A. & CANADIAN MODELS ONLY]

AMPLIFIER SECTION:

Minimum Continuous Watts per Channel, both Channels Driven	
into 8 ohms	30 W
into 4 ohms	33 W
Power Band	
at 8 ohms	20 Hz - 20 kHz
at 4 ohms	20 Hz - 20 kHz
Total Harmonic Distortion	
at 8 ohms	0.08%
at 4 ohms	0.15%
I.M. Distortion	
(I.H.F. method, 20 Hz and 7 kHz mixed 4:1 at rated power output)	
at 8 ohms	0.08%
Damping Factor at 20 Hz	30

PREAMPLIFIER SECTION:

Phono	
Input Overload at 1 kHz	120 mV
Equivalent Input Noise, "A" weighted	2 μV
Input Sensitivity (Input Impedance, 47 kohms)	2.8 mV
Frequency Response (RIAA, 20 Hz to 20 kHz)	±0.75 dB
High Level Inputs (Aux and Tape)	
Input Sensitivity	180 mV
Input Impedance	20 kohms

AM/FM TUNER SECTION:

Sensitivity	
IHF Usable (Mono)	10.8 dBf (1.9 μV)
IHF 50 dB Quieting	
Mono	14.5 dBf (2.9 μV)
Stereo	37.7 dBf (42 μV)
Distortion, Mono and (Stereo) at 65 dBf	
1000 Hz	0.2% (0.35%)
Hum and Noise at 65 dBf (1000 μV)	
Mono	-70 dB
Capture Ratio at 65 dBf (1000 μV)	1.0 dB
Alternate Channel Selectivity	60 dB
Spurious Response Rejection	90 dB
Image Response Rejection	50 dB
IF Rejection (Balanced)	90 dB
AM Suppression	50 dB
Stereo Separation 1000 Hz	45 dB
AM Usable Sensitivity (IHF)	20 μV
AM Distortion (THD) at 30% Modulation	1.0%
AM Signal-to-Noise Ratio	50 dB

GENERAL:

Power Requirements	120 V AC, 60 Hz
Power Consumption at rated output, both channels operating	150 W
Idling Power (Volume Control at zero)	23 W
Dimensions	
Panel Width	17-1/4" (440 mm)
Panel Height	5-3/8" (137 mm)
Depth	14-1/16" (357 mm)
Weight	
Unit alone	10 kg (22 lbs.)
Packed for shipment	11.5 kg (25.3 lbs.)

[FOR EUROPEAN MODEL ONLY]

AUDIO SECTION:

POWER OUTPUT, DIN, 4 OHM, PER CHANNEL	56 W
POWER OUTPUT, FTC AMERICAN STANDARDS, 4 OHM, PER CHANNEL	33 W
TOTAL HARMONIC DISTORTION AT RATED POWER OUTPUT	0.15 %
I.M. DISTORTION AT RATED POWER OUTPUT (250 Hz AND 8 kHz MIXED, AMPLITUDE RATIO 4:1)	0.15 %
POWER BANDWIDTH	10 Hz ~ 40 kHz
POWER OUTPUT, DIN, 8 OHM, PER CHANNEL	48 W
POWER OUTPUT, FTC AMERICAN STANDARDS, 8 OHM, PER CHANNEL	30 W
TOTAL HARMONIC DISTORTION AT RATED POWER OUTPUT	0.08%
I.M. DISTORTION AT RATED POWER OUTPUT (250 Hz AND 8 kHz MIXED, AMPLITUDE RATIO 4:1)	0.08%
POWER BANDWIDTH	10 Hz ~ 40 kHz
DAMPING FACTOR 8 OHM	66 64 53
	(40 Hz) (1 kHz) (12.5 kHz)

Frequency Response	
Phono (RIAA)	±1.0 dB
Aux (±1 dB)	18 Hz ~ 30 kHz
Signal-to-Noise Ratio	
Phono	72 dB
Aux	80 dB
Input Terminals	
Phono: Input Impedance	47 kohms
Input Sensitivity	2.8 mV
Overload Margin	30 dB
Aux: Input Impedance	20 kohms
Input Sensitivity	180 mV
Overload Margin	35 dB
Phono Equivalent Input Noise	1.2 µV
Phono Dynamic Range (Ratio of input overload to equivalent input noise)	100 dB
Channel Balance (0 to -40 dB/40 Hz ~ 16 kHz)	
Phono	2.5 dB
Aux	2.0 dB
Interchannel Crosstalk	
Phono 1 kHz	35 dB
Aux 1 kHz	43 dB
Tape 1 kHz	55 dB
Intersource Crosstalk (Worst Point)	
1 kHz	51 dB
Output Voltage, 1 kHz	
Tape Out	500 mV
Output Impedance, 1 kHz	
Tape Out	200 ohms
Headphone Jack Load Impedance	8 ohms

FM TUNER SECTION:

Frequency Range	87.4 ~ 109 MHz
Usable Sensitivity 40 kHz Deviation, 98 MHz	
Mono, S/N 26 dB	1.7 µV
Stereo, S/N 46 dB	48 µV
Alternate Channel Selectivity, 98 MHz ±300 kHz	36 dB
Image Response Rejection, 98 MHz	50 dB
IF Rejection, 98 MHz	100 dB
Spurious Response Rejection, 98 MHz	110 dB
AM Suppression, 98 MHz	52 dB

Signal-to-Noise Ratio, 98 MHz

Unweighted: Mono	62 dB
Stereo	55 dB
Weighted: Mono	66 dB
Stereo	60 dB
Pilot Signal & Subcarrier Rejection	
19 kHz	58 dB
38 kHz	58 dB
Total Harmonic Distortion, 98 MHz	
Mono	0.1%
Stereo	0.2%
Frequency Response	
30 Hz ~ 15 kHz	+0.5 dB, -2.0 dB
Separation	
Stereo	45 dB
Channel Balance	0.5 dB
Output Voltage, 1 kHz	600 µV
Output Impedance, 1 kHz	4.4 kohms
Acceptable Load Impedance, 1 kHz	47 kohms
Antenna Terminals	
Balanced	300 ohms
Unbalanced	75 ohms

AM TUNER SECTION:

Frequency Range	515 ~ 1650 kHz
Usable Sensitivity (26 dB S/N 30% Mod., 1 MHz)	30 µV
Selectivity, 1 MHz ±9 kHz	20 dB
Image Rejection, 1 MHz	41 dB
IF Rejection, 1 MHz	55 dB
Spurious Response Rejection, 1 MHz	38 dB
Signal-to-Noise Ratio, 1 MHz	43 dB
Frequency Response, 1 MHz ±3 dB	40 Hz ~ 2.2 kHz
Total Harmonic Distortion, 1 MHz	1.0%

GENERAL:

Power Requirements	220 V AC, 50 Hz
	(N version is featuring an external voltage selector for use on 110/120/240 V.)
	Other versions can be converted by a qualified technician to operate on 110/120/240 V.)
Power Consumption at Rated Output, Both Channels Operating	150 W
Idling Power	28 W
Semiconductor Complement	
Integrated Circuits	5
Transistors	33
Diodes	28
Field Effect Transistor	1
Dimensions	
Panel Width	17-3/8" (440 mm)
Panel Height	5-3/8" (137 mm)
Depth	14-1/8" (358 mm)
Weight	
Unit alone	24.2 lbs (11.0 kg)
Packed for shipment	27.5 lbs (12.5 kg)

SCHEMATIC DIAGRAM

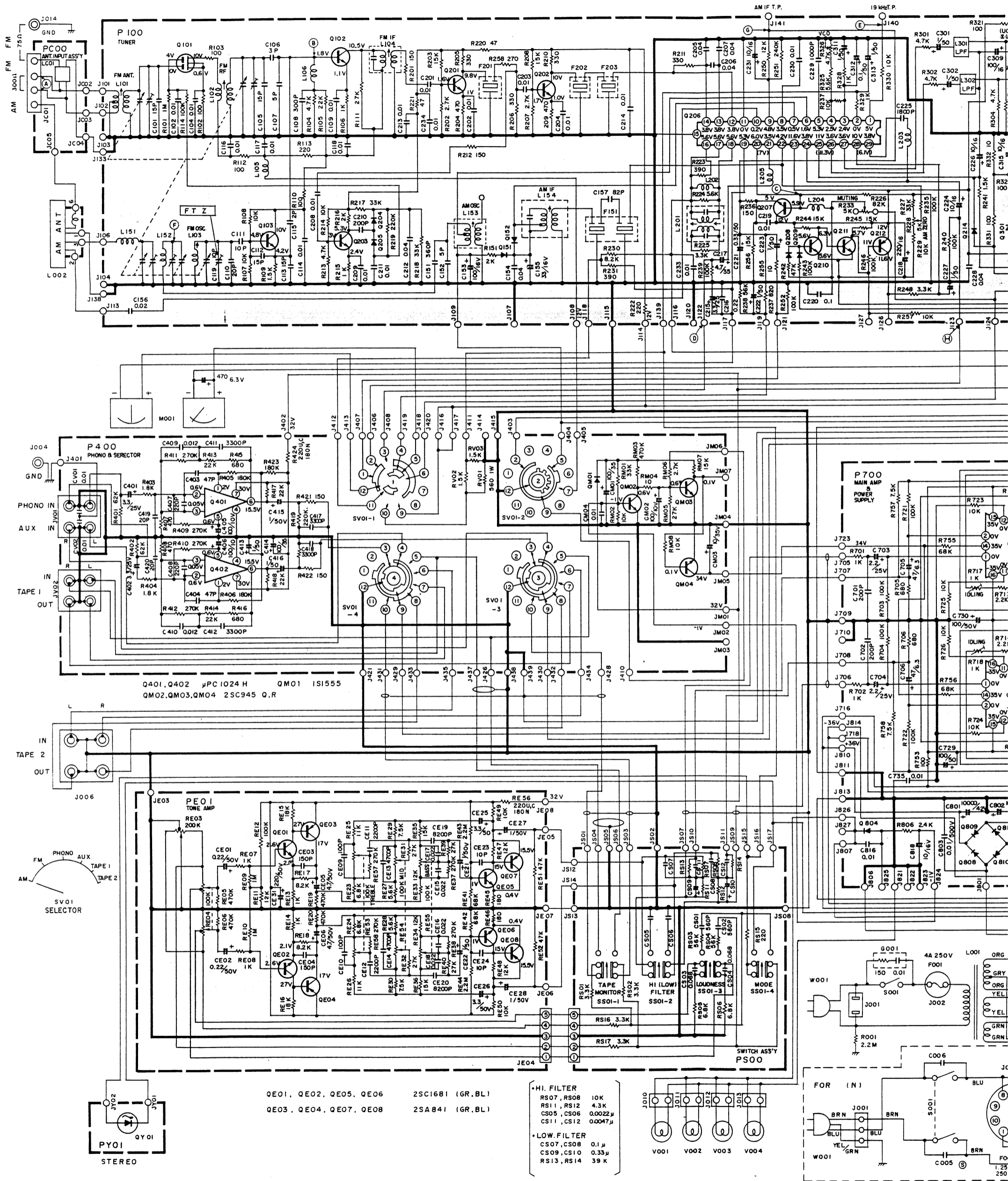

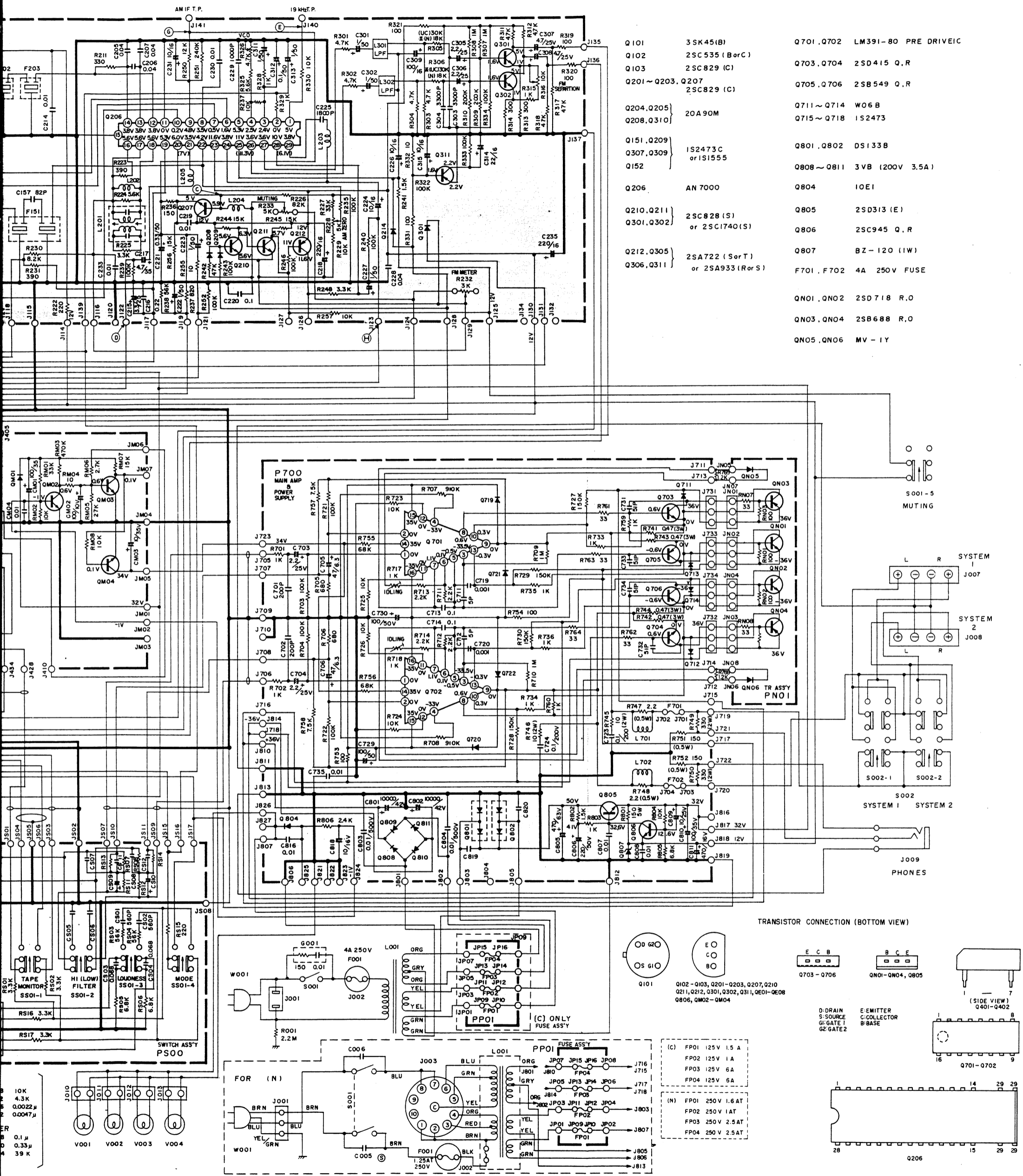

Q101	3SK45(B)	Q701, Q702	LM391-80 PRE DRIVE IC
Q102	2SC535 (BorC)	Q703, Q704	2SD415 Q,R
Q103	2SC829 (C)	Q705, Q706	2SB549 Q,R
Q201 ~ Q203, Q207	2SC829 (C)	Q711 ~ Q714	W06 B
Q204, Q205	20A90M	Q715 ~ Q718	1S2473
Q208, Q310		Q801, Q802	DS133B
Q151, Q209		Q808 ~ Q811	3VB (200V 3.5A)
Q307, Q309	1S2473 C or 1S1555	Q804	10E1
Q152		Q805	2SD313 (E)
Q206	AN 7000	Q806	2SC945 Q,R
Q210, Q211	2SC828 (S) or 2SC1740(S)	Q807	BZ-120 (1W)
Q301, Q302		F701, F702	4A 250V FUSE
Q212, Q305	2SA722 (SorT) or 2SA933 (RorS)	QN01, QN02	2SD718 R,O
Q306, Q311		QN03, QN04	2SB688 R,O
		QN05, QN06	MV-1Y

TRANSISTOR CONNECTION (BOTTOM VIEW)

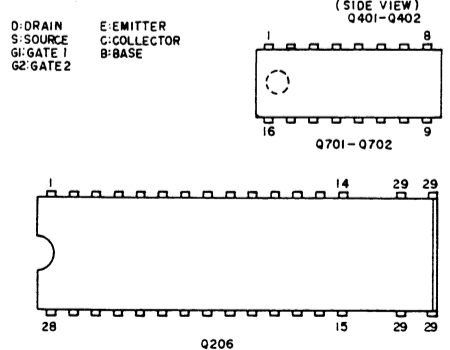
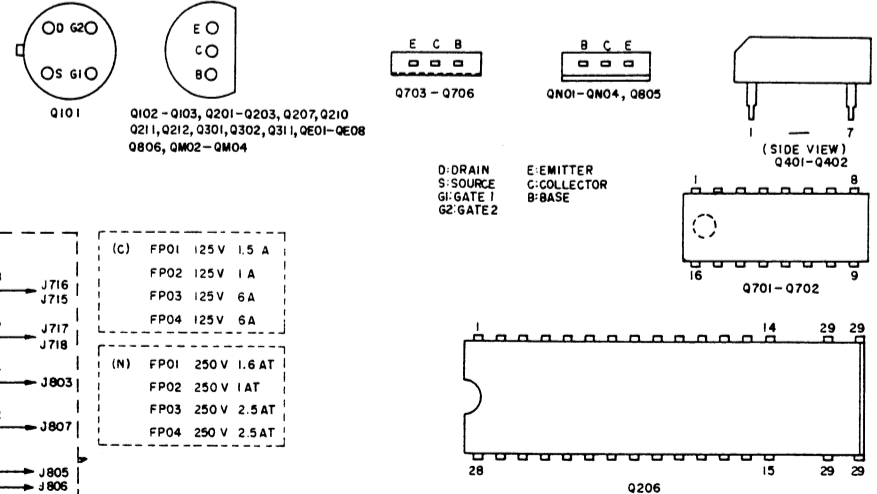

- 10K
- 4.3K
- 0.0022μ
- 0.0047μ
- 0.1μ
- 0.33μ
- 39K