

marantz.

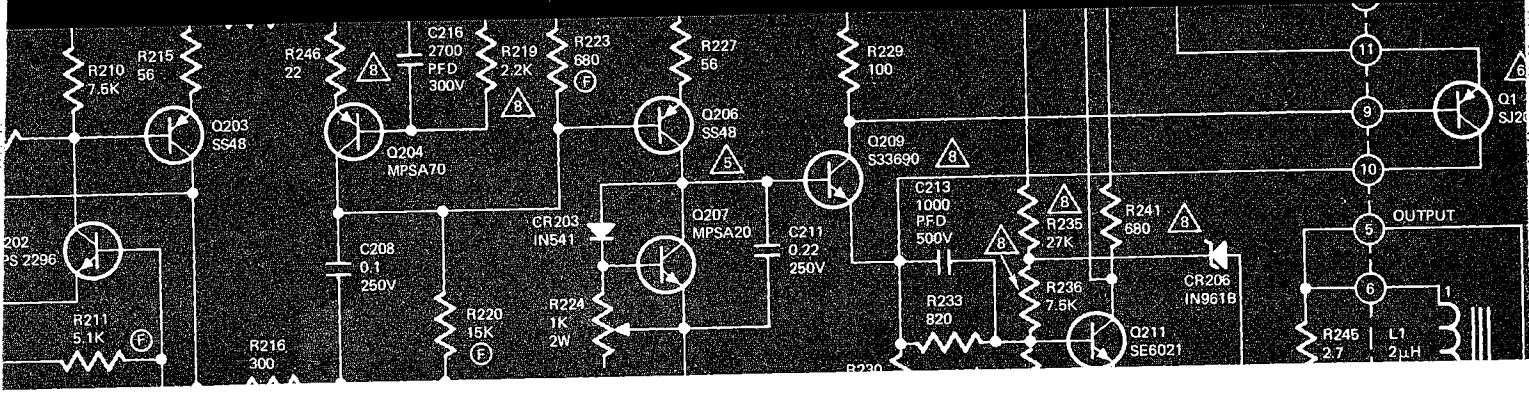

3

MODEL 19

SERVICE MANUAL

19

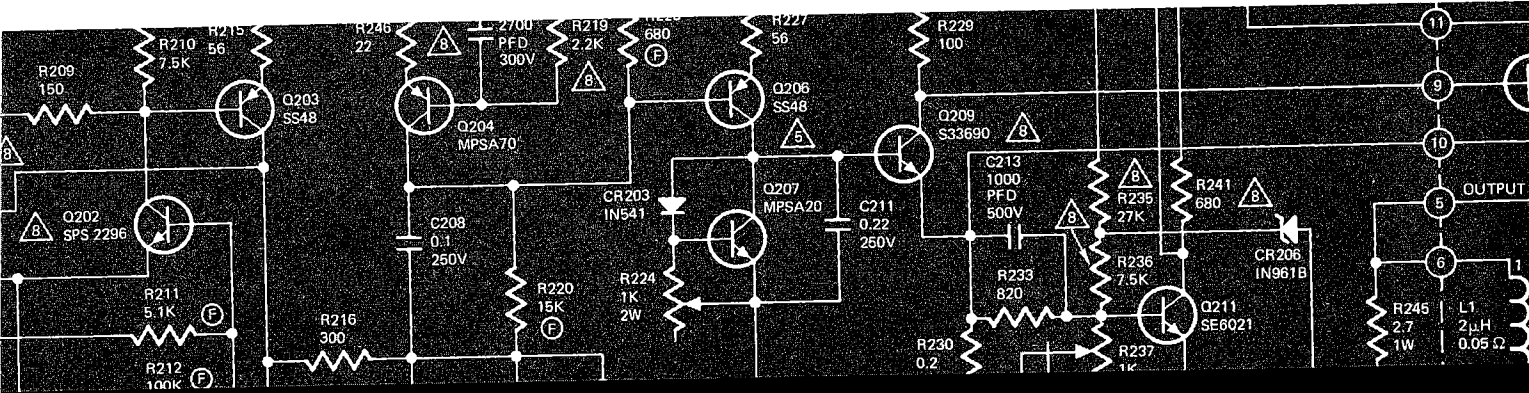

Stereophonic Receiver

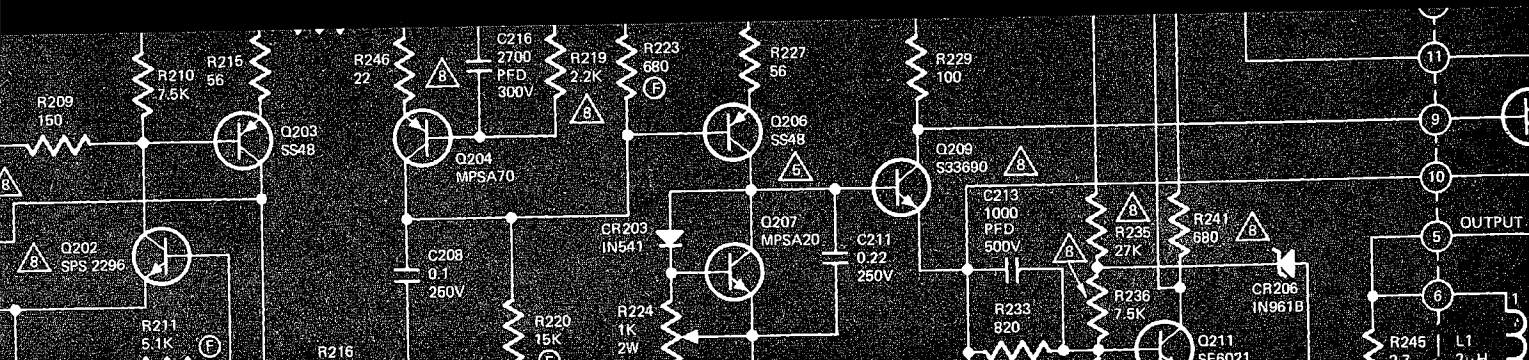

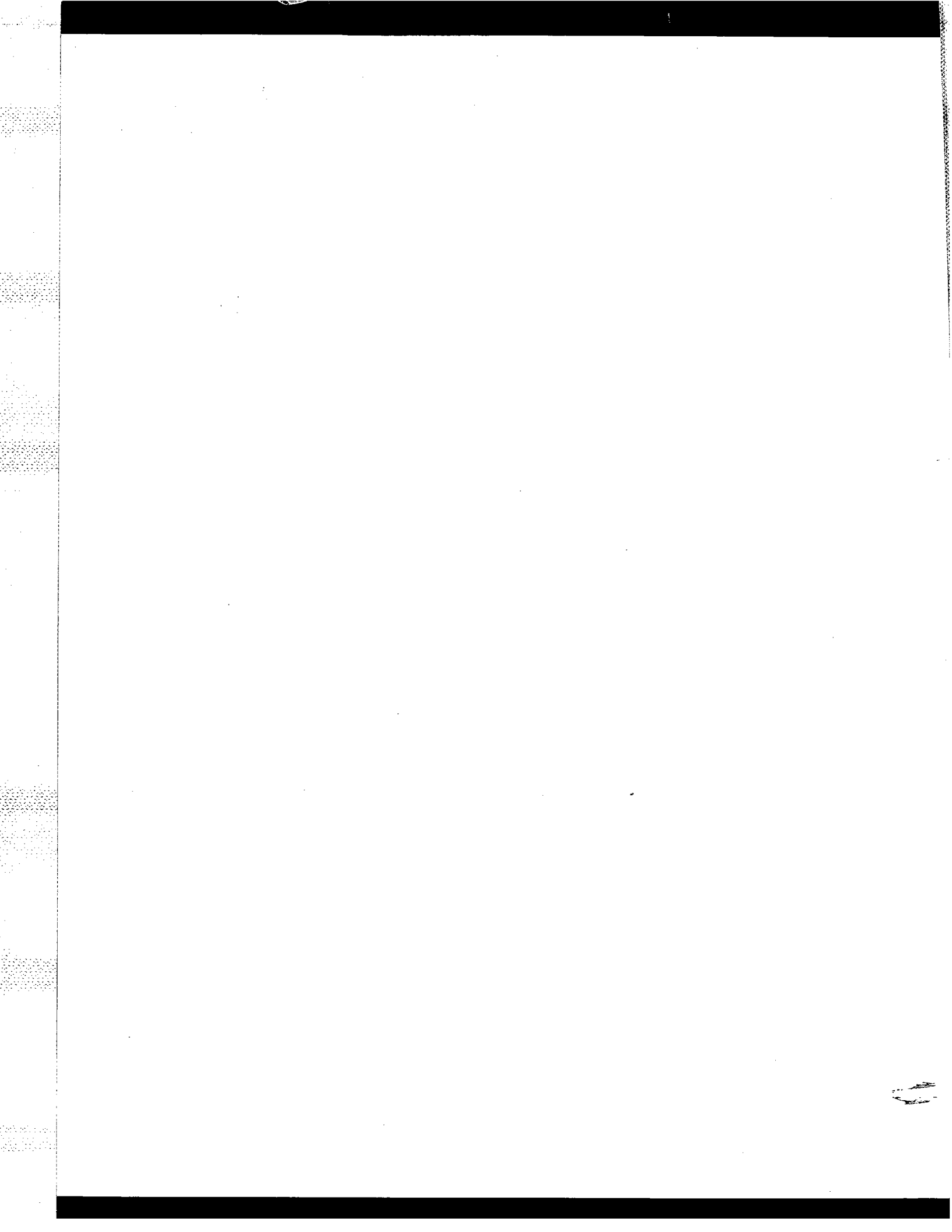

marantz

MODEL NINETEEN



STEREOPHONIC RECEIVER

SERVICE MANUAL

MARANTZ CO., INC. • P.O. Box 99 • SUN VALLEY, CALIFORNIA • 91352
A WHOLLY-OWNED SUBSIDIARY OF SUPERSCOPE INC., SUN VALLEY, CALIFORNIA 91352

TABLE OF CONTENTS

	PAGE
1. LIST OF ILLUSTRATIONS	1
2. INTRODUCTION	2
3. SERVICE NOTES	2
4. TECHNICAL SPECIFICATIONS	6
5. PERFORMANCE VERIFICATION	7
6. TROUBLE ANALYSIS	13
7. POWER SUPPLY ASSEMBLY	18
8. TIME DELAY ASSEMBLY	18
9. FRONT END ASSEMBLY	21
10. I.F. ASSEMBLY	25
11. LIMITER ASSEMBLY	29
12. DETECTOR ASSEMBLY	33
13. MPX OSCILLATOR ASSEMBLY	37
14. MPX MATRIX ASSEMBLY	41
15. PHONO AMP ASSEMBLY	45
16. TONE ASSEMBLY	49
17. DRIVER ASSEMBLY	53
18. POWER AMP ASSEMBLY	57
19. SCOPE ASSEMBLY	61
20. HI-LOW FILTER ASSEMBLY (NEW)	65
21. FUNCTION SWITCH ASSEMBLY	65
22. HI-LOW FILTER ASSEMBLY (OLD)	68
23. PARTS LIST	70

LIST OF ILLUSTRATIONS

	PAGE		
1. AC POWER CONTROL BOX SIMPLIFIED SCHEMATIC	5		
2. AMPLIFIER OUTPUT LOAD BOX SIMPLIFIED SCHEMATIC	5		
3. AUDIO TEST SETUP	7		
4. RIAA EQUALIZATION CURVE	9		
5. FM TEST SETUP	11	16. TONE	
6. DIAL CORD STRINGING DIAGRAM	17	A - SCHEMATIC DIAGRAM	49
7. POWER SUPPLY		B - CONDUCTOR DIAGRAM	50
A - COMPONENT DIAGRAM	18	C - COMPONENT DIAGRAM	51
B - CONDUCTOR DIAGRAM	19	D - CONDUCTOR PATTERN DIAG	51
C - SCHEMATIC DIAGRAM	20	E - TONE CONTROL CURVES	52
8. TIME DELAY		17. DRIVER	
A - COMPONENT DIAGRAM	18	A - SCHEMATIC DIAGRAM	53
B - CONDUCTOR DIAGRAM	19	B - CONDUCTOR DIAGRAM	54
C - SCHEMATIC DIAGRAM	20	C - COMPONENT DIAGRAM	55
9. FRONT END		D - CONDUCTOR PATTERN DIAG	55
A - SCHEMATIC DIAGRAM	21	18. POWER AMP	
B - OVERVIEW	22	A - SCHEMATIC DIAGRAM	57
C - TOP VIEW	23	B - CONDUCTOR DIAGRAM	59
D - BOTTOM VIEW	23	C - COMPONENT DIAGRAM	59
10. I.F.		19. SCOPE	
A - SCHEMATIC DIAGRAM	25	A - SCHEMATIC DIAGRAM	61
B - CONDUCTOR DIAGRAM	27	B - CONDUCTOR DIAGRAM	62
C - COMPONENT DIAGRAM	27	C - COMPONENT DIAGRAM	63
D - CONDUCTOR PATTERN DIAG	28	D - CONDUCTOR PATTERN DIAG	63
11. LIMITER		20. HI-LOW FILTER (NEW)	
A - SCHEMATIC DIAGRAM	29	A - SCHEMATIC DIAGRAM	65
B - CONDUCTOR DIAGRAM	31	B - CONDUCTOR DIAGRAM	66
C - COMPONENT DIAGRAM	31	C - COMPONENT DIAGRAM	67
D - CONDUCTOR PATTERN DIAG	32	21. FUNCTION SWITCH	
12. DETECTOR		A - SCHEMATIC DIAGRAM	65
A - SCHEMATIC DIAGRAM	33	B - CONDUCTOR DIAGRAM	66
B - COMPONENT DIAGRAM	35	C - COMPONENT DIAGRAM	67
C - CONDUCTOR DIAGRAM	35	22. HI-LOW FILTER (OLD)	
D - CONDUCTOR PATTERN DIAG	35	A - COMPONENT DIAGRAM	68
13. MPX OSCILLATOR		B - CONDUCTOR DIAGRAM	68
A - SCHEMATIC DIAGRAM	37	C - SCHEMATIC DIAGRAM	69
B - CONDUCTOR DIAGRAM	39	D - RESPONSE CURVE	69
C - COMPONENT DIAGRAM	39	23. MODEL 19	
14. MPX MATRIX		A - TOP VIEW	Back Cover Flip-Up
A - SCHEMATIC DIAGRAM	41	B - BOTTOM VIEW	Back Cover Flip-Up
B - CONDUCTOR DIAGRAM	43	C - FRONT VIEW	Back Cover Flip-Up
C - COMPONENT DIAGRAM	43	24. MODEL 19 UNIT SCHEMATIC	Back Cover Flip-Up/ Flip Over
15. PHONO AMP			
A - SCHEMATIC DIAGRAM	45		
B - CONDUCTOR DIAGRAM	46		
C - COMPONENT DIAGRAM	47		
D - CONDUCTOR PATTERN DIAG	47		

INTRODUCTION

This service manual was prepared for and is intended for use only by factory authorized warranty repair stations and other equally qualified and equipped individuals or corporations.

The adjustment, maintenance, and troubleshooting information listed herein is for the Marantz Model 19 FM Stereophonic Receiver. Service of any type on this unit should be attempted **ONLY** by **EXPERIENCED PERSONNEL**, ones knowledgeable in solid state FM tuner and amplifier operation and the **PROPER** use of the associated test equipment listed herein. **ALL** instructions should be read **CAREFULLY** and **FULLY** understood **BEFORE** proceeding with **ANY** service. To better understand the functions of the Model 19 receiver you may wish to consult the Model 19 **OWNER'S MANUAL** which provides a brief functional and technical description including a block diagram.

CAUTION

1. **HAZARDOUS VOLTAGES EXIST** on the **POWER SUPPLY AND SCOPE BOARDS** (up to 700 volts d.c.) **CARE** should be taken when working in these areas. The **MPX. OSC.** and **MATRIX BOARDS** have 200 volts d.c. on them, **CAUTION** should be used here also.
2. **DO NOT** discharge **ANY CAPACITORS** in the Model 19 with a dead short, *i.e.*, a screw driver blade. To do so may cause multiple failures of the field effect transistors contained in it. **ALSO** if during troubleshooting you wish to place outside capacity in parallel with **ANY** capacitors in the Model 19, turn the power **OFF FIRST**. Discharge **BOTH** the **INTERNAL** and **EXTERNAL** capacitors with a 10 ohm 1 watt resistor, then connect them in parallel and restore power to the unit.

SERVICE NOTES

The service notes that follow, and the "symptoms" (and their remedies) listed in the alignment and troubleshooting sections of this manual identify some of the service problems that have been or may

be encountered in the field. As the Marantz Company becomes aware of other field problems, supplementary service bulletins will be issued to all warranty stations. To improve this service, all problems (and/or their solutions) not covered in this service manual should be brought to the attention of the National Service Manager at our Sun Valley, California location. (See rear cover of Manual for address.)

NOTE

If a defect is found in an assembly and the assembly does not contain the latest modifications and/or changes listed herein (or in future service bulletins), they should be performed at once.

1. PROLONGING C.R.T. LIFE

Maintaining the display on the screen of the C.R.T. for prolonged or excessive periods or with excessive brightness will eventually cause the phosphor coating on the face of the C.R.T. to develop "burned areas"; to extend the life of the C.R.T., it is recommended that the **SCOPE ON** pushbutton be released when the scope is not actually in use.

NOTE

If excessive brightness occurs when trace is on screen, see **SCOPE BOARD** section of this manual for adjustment.

2. EXCESSIVE HUM (TAPE, AUX 1&2 INPUTS)

Early production units may contain capacitors which will lose capacity in the field. In the event the above symptom is encountered check **C102 (AB&C)**, on the power supply board, for insufficient capacity. This can be determined by: 1. Measuring the ripple on the -36V regulated line (not to exceed 2.5 MV peak to peak). 2. Or paralleling 500-600 MFD capacitor rated at 40 volts or greater with sections "A" and "C" of **C102**. If **C102** is defective, replace it with the newer type unit manufactured by P. R. Mallory.

3. EXCESSIVE HUM (PHONO)

Some units may develop phono hum which cannot be corrected by normal means, *i.e.*, replacement of faulty transistors, capacitors, etc. or wire "tuning." The fault may be in the phono 1-2 switch on the function switch board. The problem may be corrected by cleaning the switch with a known good brand of contact cleaner.

4. TONE CONTROL KNOBS NOT MECHANICALLY CENTERED

This condition is normal to a certain degree. This is because the Model 19 tone control knobs were factory installed so that the notch on the knobs lines up exactly with the dot on the front panel at the exact spot of electronic flatness, not center of mechanical rotation (see tone control board for procedure). Offset may be from 0 degrees to ± 30 degrees.

5. TAPE MONITOR FEED-THRU

Some complaints of feed-thru in the tape monitor function have occurred. However, this is usually done with the volume control turned up well past normal listening range. The unit may be checked and if the feed-thru is down 40 to 50 dB below the source signal at 1 KHz the unit is functioning normally and no service is required. See note No. 8.

6. C.R.T. SOCKET SHORTS

Any Model 19 returned for service should be checked to be certain that pin No. 10 has been removed from the C.R.T. socket. If it has not been removed, disassemble the socket and remove it. If not removed, it may cause a short and damage the circuitry of the scope board.

7. SHORTS IN C.R.T.

If a problem exists in the "scope" circuit, and a short seems to exist on the "scope board," disconnect the C.R.T. and check it for internal shorts. This may be the problem and not the board. If the C.R.T. is shorted, DO NOT attempt repairs. Replace it with a new one.

8. TAPE AND TAPE MONITOR CROSS TALK

Units prior to S/N 1501 may have a problem with cross talk between channels on "TAPE" and "TAPE MONITOR." Check to see if the following change has been completed. If not, and customer complains about above, incorporate the following:

The green wire going to pin No. 1527 from cable marked No. 6 is to be moved to pin No. 1526. The green wire going to pin No. 1526 from cable marked No. 7 is to be moved to pin No. 1527. The green wire going to the selector switch (front deck) pin No. 5 from cable marked No. 7 is to be moved to the selector switch pin No. 11. The green wire going to the selector switch pin No. 11 from cable marked No. 6 is to be moved to the selector switch pin No. 5.

220 VOLT A.C. AND 50 MICROSECOND (EUROPEAN DE-EMPHASIS CONVERSION)

To convert the Model 19 to 220 V.A.C. and 50 μ sec (European) de-emphasis, perform the following steps.

1. Remove top and bottom covers.
2. Orient the Model 19 so that the rear of the unit is toward you.
3. Place unit upside down.
4. Locate TB4, the terminal strip that is approximately in the center (left to right) of the unit and towards you, just between the power transformer and the rear of the chassis.
5. Unsolder and remove the two jumpers on TB4 (black-yellow No. 1 to black-white No. 2 and black-green No. 3 to black No. 4).
6. Using one of the removed jumpers, connect the black-white No. 2 and black-green No. 3 on TB4.
7. Replace the 2-1/2 amp fuse in the unit with the 2 amp, 250 volt fuse, part No. 451-1006 supplied with the 220 volt conversion kit part No. 107-1001-1.
8. Turn unit right side up. (Rear towards you.)
9. Locate MPX MATRIX Board (the board on your right, and copper side, towards you).
10. Locate R615 and R616 ($11.3K \pm 1\%$) on MPX MATRIX Board (top right side of board, as viewed from "copper" side) next to L601 and L602 toroid coils.
11. Two ways are available for the remaining conversion;
 - a. Remove R615 and R616 and replace them with two $5.3K \pm 1\%$ resistors part No. 430-4530 in the 220 volt conversion kit or,
 - b. Connect two $10K \pm 1\%$ resistors, part No. 330-1019, one each in parallel with R615 and R616.
12. Replace top and bottom covers.
13. Affix caution label, part No. 180-1017. The Model 19 is now ready for 220 volt A.C. -50 μ sec de-emphasis (European) use.

TEST EQUIPMENT REQUIRED FOR SERVICING

Table 1 lists the test equipment required for servicing the Model 19 FM Stereo Receiver. The wattmeter, ac voltmeter, and variac may be assembled as a test fixture as shown schematically in Figure 1, and the load resistors and ac ammeter may be assembled into a second test fixture as shown in Figure 2.

Item	Manufacturer and Model No. (or equivalent)	Use
Distortion Analyzer	Hewlett Packard, Model 331A or 333A	Measures distortion and voltage of amplifier output.
Audio Oscillator	Weston Model CVO-100P (NOTE: Less than 0.02 percent residual distortion is required.)	Sinewave and squarewave signal source.
Oscilloscope	Tektronix, Model 503; or 422	Waveform analysis and troubleshooting.
VTVM	RCA Senior Volt-Ohmyst, Model WV-98C	Voltage and resistance measurements.
AC Wattmeter	Simpson, Model 390	Monitors primary power consumption of amplifier.
AC Ammeter (0 to 10 amps)	Commercial Grade	Monitors amplifier output under short circuit condition.
Line Voltmeter (0 to 150 V.A.C.)	Commercial Grade	Monitors potential of primary power to amplifier.
Variable Autotransformer (0 to 140 V.A.C., 10 amps)	Powerstat, Model 116B	Adjusts level of primary power to amplifier.
Shorting Plug	Use phono plug with 600 ohms across center pin and shell.	Shorts amplifier input to eliminate noise pickup.
Power Supply Bleeder Resistor (10 ohms at 1 W)	Commercial Grade	Discharges power supply filter capacitors prior to disassembly or resistance measurements.
Output Load Resistor ($8\ \Omega \pm 0.5\%$, 100 W)	Commercial Grade	Provides 8-ohm load for amplifier output termination.
Output Load Resistor ($4\ \Omega \pm 0.5\%$, 100 W)	Commercial Grade	Provides 4-ohm load for amplifier output termination.
Output Load Capacitor (0.5 mfd)	Mylar	Provides capacitive load for instability checks.
AC Power Control Box	Optional Item. Fabricate in accordance with Figure 1.	Monitors and controls primary power for amplifier.
Amplifier Output Load Box	Optional Item. Fabricate in accordance with Figure 2.	Provides various amplifier loads and can monitor shorted output.
FM-MPX Generator	Sound Technology, Model 1000A	FM and MPX alignment.
10.7 MHz Crystal OSC.	Any unit with frequency accuracy of $\pm 0.01\%$.	FM alignment (detector).
88, 98, 108 MHz and 1 M Hz Harmonic Crystal OSC	Any unit with frequency accuracy of $\pm 0.01\%$.	FM alignment (front end).
DC VTVM	Any unit with 0.1 volt full scale range with $\pm 3\%$ or better accuracy.	Bias and DC balance adjustment.
Audio Bandpass Filter	-3 dB at 20 Hz and 20 KHz with 12 dB/octave cutoff slopes.	Noise measurements.

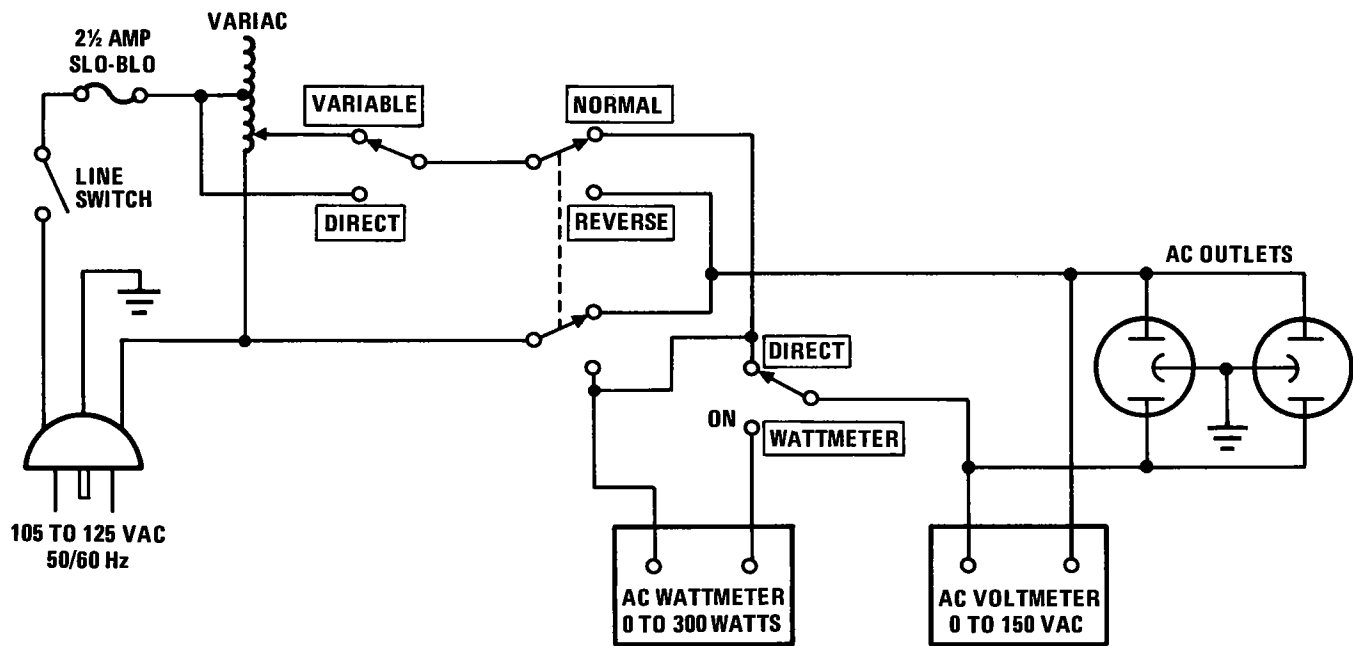

FIGURE 1 – AC POWER CONTROL BOX SIMPLIFIED SCHEMATIC

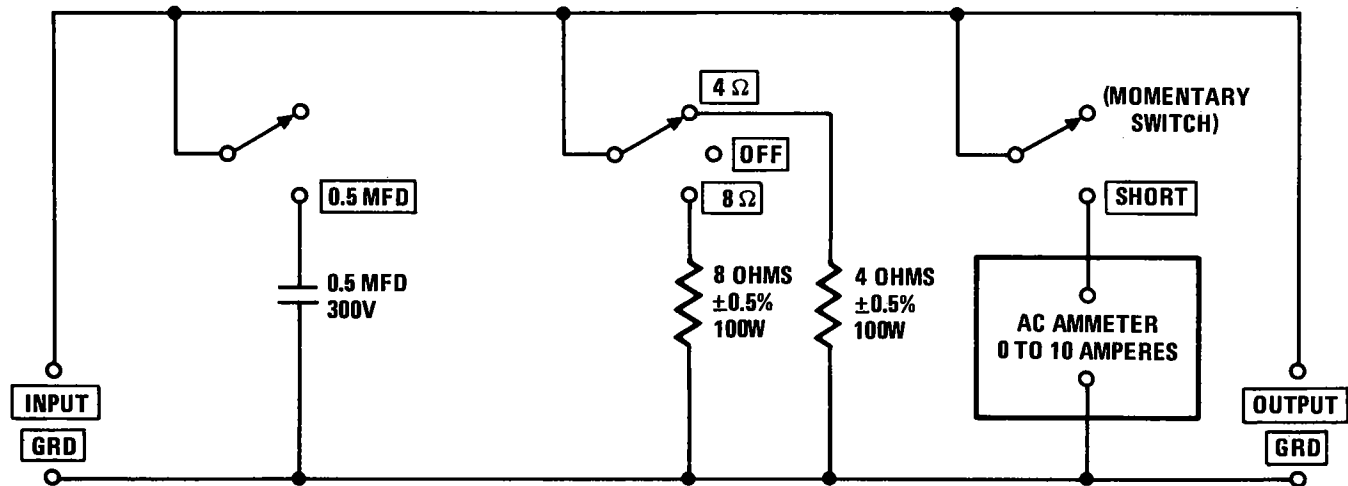

FIGURE 2 – AMPLIFIER OUTPUT LOAD BOX SIMPLIFIED SCHEMATIC

TECHNICAL SPECIFICATIONS

AUDIO CIRCUITS:

Rated continuous (RMS) power output per channel, both channels operating simultaneously, 20 Hz to 20,000 Hz	50 Watts at 4 and 8 ohms 30 Watts at 16 ohms
High-level hum and noise (ref. 40W at 8 ohms)	-80 dB
Phono hum and noise	1 μ V equivalent input*
Dynamic range (phono input to tape recording output)	98 dB Minimum
I. M. Distortion (SMPTE), at rated power	0.2% Maximum
Distortion decreases as output is lowered	
Total Harmonic Distortion, at rated power	0.15% Maximum
Distortion decreases as output is lowered	
Power Bandwidth (IHF) for 0.15% THD	7 Hz to 40,000 Hz
Damping Factor (ref. 8 ohms)	80 Minimum
Frequency Response	
High-level 20 Hz to 20,000 Hz	\pm 0.5 dB
RIAA Phono Equalization	\pm 0.5 dB
Input Sensitivity (for 50W at 8 ohms)	
High-level	100 mV
Phono (1,000 Hz)	1 mV
Input Impedance	
High-level	100,000 ohms
Phono	47,000 ohms
Channel Separation 20 Hz to 20,000 Hz	35 dB Minimum

FM SECTION:

IHF Usable Sensitivity	2.0 μ V
Quieting Slope	-55 dB at 5 μ V
	-62 dB at 10 μ V
	-70 dB at 50 μ V
Total Harmonic Distortion, 400 Hz, 100% Mod. (Mono and Stereo)	0.15% Maximum
Frequency Response (ref. 75 μ sec. de-emphasis) 20 to 15 KHz	\pm 0.5 dB
Multiplex Separation	1,000 Hz 45 dB Minimum
	20 Hz 40 dB Minimum
	10,000 Hz 35 dB Minimum
	15,000 Hz 30 dB Minimum
Sub-Carrier (38 KHz) Suppression	60 dB Minimum
SCA Pilot Carrier (67 KHz) Suppression	65 dB Minimum

GENERAL:

Power Requirements	105 to 125 VAC
	50 to 60 Hz
At rated output, both channels operating	260 Watts
Idling Power (Volume Control at zero)	50 Watts
Overall Dimensions (including feet):	18 $\frac{1}{4}$ Wide x 6-1/8 High x 16 Deep
Front Panel Dimensions:	18 $\frac{1}{4}$ Wide x 5-3/4 High
Shipping Weight:	46 Pounds
Optional Cabinet (WC-9) Shipping Weight	11 Pounds
Dimensions When Mounted in Accessory Cabinet	19 Wide x 7 High x 16 Deep

*Measured (with input shorted) through an audio bandpass filter -3 dB at 20 Hz and 20,000 Hz with 12 dB/octave cutoff slopes. The equivalent input noise figure allows a true calculation of phono signal/audio-noise ratio without the inclusion of errors resulting from arbitrary signal level inputs (which frequently are chosen to optimize the S/N ratio). For example, a phono signal of 5 mV (5,000 μ V/1 μ V) results in a 74 dB signal/noise ratio.

PERFORMANCE VERIFICATION

A. TEST EQUIPMENT

Refer to TABLE 1 for required test equipment.

B. PRELIMINARY PROCEDURES — AUDIO

1. Make the test setup shown in figure 3 with instrument controls set in the following positions:

Line Switch — Off

Variable-Line Switch — Variable

Watt Meter Switch — On

Variac — 0 (fully C.C.W.)

Load — 8 ohms (0.5 mfd - off)

Audio Generator — Frequency 1 KHz; output minimum

Distortion Analyzer — 30 volts range

Note: In the tests that follow, if the distortion analyzer used does not contain a built-in voltmeter, a V.T.V.M. may be substituted.

2. Make sure that connections between the resistive load and the "MAIN" speaker terminals of the Model 19 have negligible resistance compared with the resistance of the load

itself. Appreciable resistance in wiring adds to the total load, resulting in inaccurate measurements of power output.

3. Remove Model 19 top cover.
4. Plug Model 19 into A.C. power control box and turn on Model 19 power switch. Set other controls as follows:

Volume — Minimum (full C.C.W.)

Selector Switch — "AUX 1"

Speaker Switch — "BOTH"

All push buttons except MUTING OFF — OUT (released)

Balance Control — Center ("notch" on "dot")

Tone Controls — "Flat" ("notches" to "dots")

C. BIAS AND D.C. BALANCE TEST

1. Turn the line switch (on A.C. power control box) on and SLOWLY advance the variac while observing the volt meter and watt meter. When the line voltage reaches 120 V.A.C. the watt meter should indicate approximately 50 watts. NOTICE: Watt meter should NEVER exceed 70 watts while variac is being increased or when set to 120 volts. If it does, turn variac off and refer to the TROUBLE ANALYSIS section of this manual.

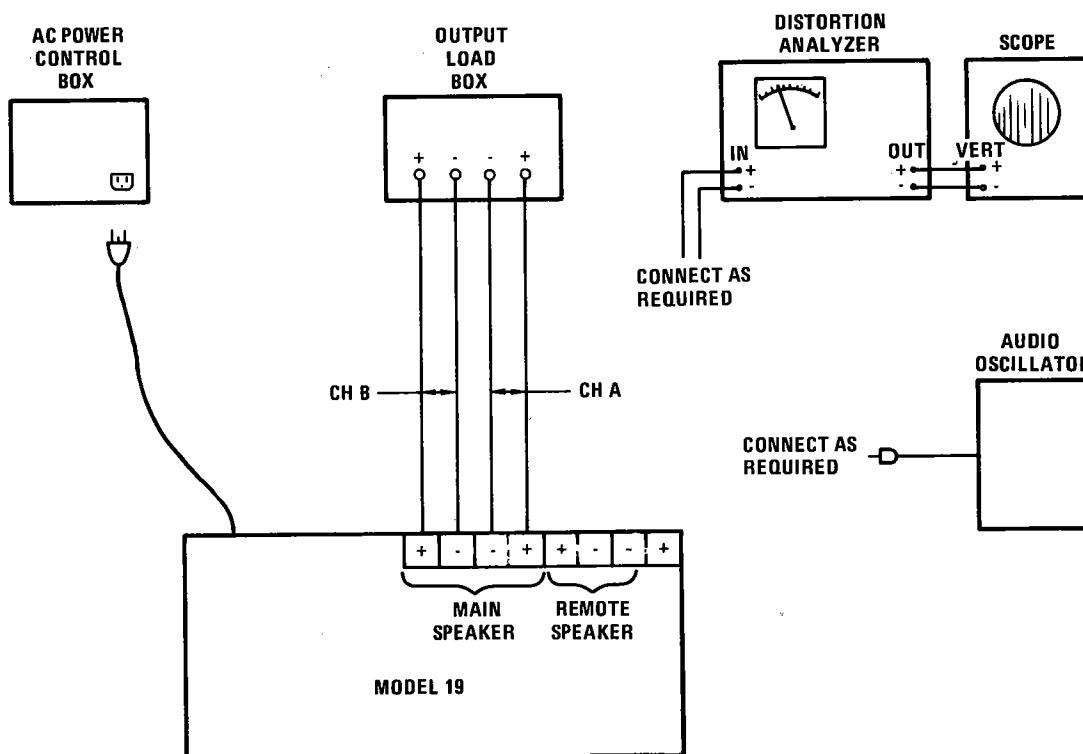

FIGURE 3. AUDIO TEST SET-UP

2. Connect D.C. V.T.V.M. across channel "A" speaker terminals ("MAIN" or "REMOTE") and check for 0 ± 10 mV.

3. Repeat step 2 for channel "B." If out of spec. on "A" or "B", refer to "DRIVER BOARD adjustments."

4. Connect D.C. V.T.V.M. (0.1 volts full scale) to pin 1214 (+) and pin 1215 (-) on channel "A" driver board. It should indicate 20 mV. ± 2 mV.

5. Repeat step 4 for channel "B." If either channel is out of spec's, refer to "POWER AMP." adjustments.

D. MAXIMUM POWER OUTPUT AND HARMONIC DISTORTION TEST

1. Connect audio oscillator to "AUX 1" inputs. Set audio oscillator to 1 KHz.

2. Connect distortion analyzer to channel "A" "REMOTE" speaker terminals and set to 30 volt range.

3. Turn volume control to maximum (full C.W.) and adjust audio oscillator for 20 volts on distortion analyzer.

4. Move distortion analyzer to channel "B" and check for 20 volts output. Readjust balance control and oscillator output as necessary to obtain 20 volts on both channels.

5. Set distortion analyzer to read distortion and null. Distortion on both channels should be less than 0.15%.

6. Set audio oscillator and distortion analyzer to 20KHz and repeat steps 2 thru 5. Distortion should be less than 0.15%. If not, check "DRIVER BOARD CONSTANT CURRENT adjustment."

7. Set audio oscillator and distortion analyzer to 20 KHz and repeat steps 2 thru 5. Distortion should be less than 0.15%. If not, check "DRIVER BOARD" and "POWER AMP." adjustments.

8. Set audio oscillator to 1KHz and repeat steps 2, 3, 4 and 5. In step 5 switch 0.5 MFD capacitor across the load and verify that distortion is no greater than 0.3% and that no parasitic oscillations occur.

9. Switch off 8 ohm load and repeat step No. 8. Note: Any parasitic oscillation in the amplifier will be displayed on the oscilloscope when capacitance is switched into the load.

E. FREQUENCY RESPONSE — HI-LEVEL

1. Set Model 19 volume control to maximum (full C.W.).

2. Connect audio oscillator to channel "A" "AUX 1" input.

3. Connect distortion analyzer to channel "A" "REMOTE" speaker terminals and set to 3 volt range.

4. Set audio oscillator to 1 KHz and adjust level for "0" dB. on distortion analyzer.

5. Sweep oscillator from 20 Hz to 20 KHz.

6. Output should remain at "0" dB ± 0.5 dB.

7. If not, check "TONE CONTROL adjustment."

8. Connect oscillator and analyzer to channel "B" as in step 2 and 3, and repeat steps 4, 5 and 6.

9. If not within ± 0.5 dB check "TONE CONTROL adjustments."

F. FREQUENCY RESPONSE — LOW LEVEL (PHONO)

1. Connect audio oscillator to channel "A" "PHONO 1" input.

2. Connect distortion analyzer to channel "A" tape output and set to 0.3 volt range.

3. Turn volume control to minimum (full C.C.W.).

4. Set audio oscillator to 1 KHz ± 10 Hz and adjust level for an indication of "0" dB. on analyzer.

5. Sweep oscillator from 20 Hz to 20 KHz (changing analyzer voltage ranges as necessary) and check output to see that it follows the curve and chart in figure 4 within ± 0.5 dB.

G. SHORT CIRCUIT TEST

CAUTION: Do not perform short circuit test if amplifier shows any sign of parasitic oscillation or if load line pots have not been set. (Approximately center of rotation — see "DRIVER BOARD adjustments".)

1. Connect audio oscillator to "AUX 1" channel "A" input.

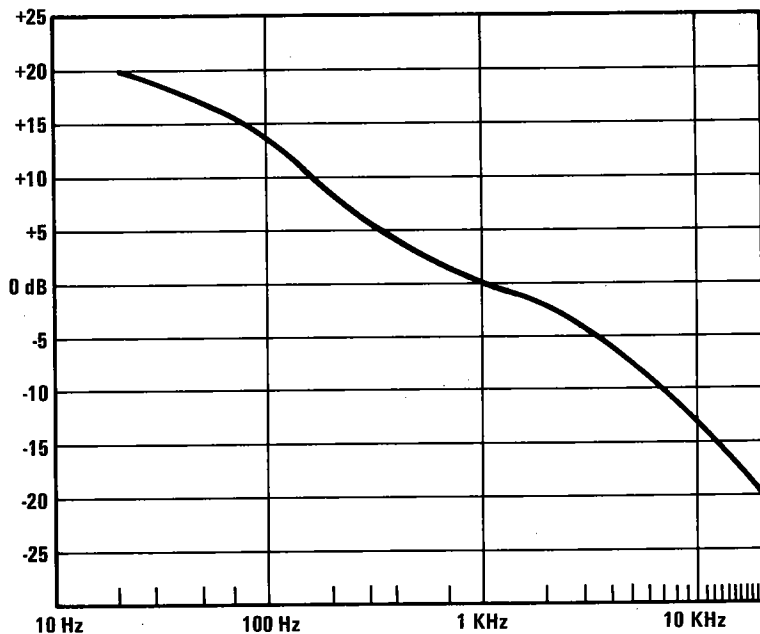

RIAA-NAB DISK REPRODUCING STD.

20 KHz	-20 dB
15 KHz	-17.17 dB
14 KHz	-16.64 dB
13 KHz	-15.95 dB
12 KHz	-15.28 dB
11 KHz	-14.55 dB
10 KHz	-13.75 dB
9 KHz	-12.88 dB
8 KHz	-11.91 dB
7 KHz	-10.85 dB
6 KHz	-9.62 dB
5 KHz	-8.23 dB
4 KHz	-6.64 dB
3 KHz	-4.76 dB
2 KHz	-2.61 dB
1000	0
700	+ 1.23 dB
400	+ 3.81 dB
300	+ 5.53 dB
200	+ 8.22 dB
100	+13.11 dB
70	+15.31 dB
50	+16.96 dB
30	+18.61 dB
20 Hz	+20 dB

FIGURE 4 – RIAA EQUALIZATION CURVE

2. Connect distortion analyzer to channel "A" "REMOTE" speaker terminals.
 3. Turn volume control to maximum (full C.W.).
 4. Adjust oscillator output for a reading of 20 volts on the distortion analyzer.
 5. Press the momentary switch to a short circuit condition and verify that the A.C. ammeter indicates between 2.2 amps and 2.8 amps.
 6. Switch oscillator and analyzer to channel "B" and repeat steps 4 and 5.
 7. If indication is out of the above range see "DRIVER BOARD LOAD LINE adjustments". Note: If current indicator exceeds 4 amps release short switch IMMEDIATELY and see TROUBLE ANALYSIS section of this manual.
- H. RELAY FUNCTION
1. Connect audio oscillator to channel "A" "AUX 1" input and set frequency to 5 Hz.
 2. Connect distortion analyzer to "REMOTE" speaker terminals and set to 30 volt range.
 3. While watching distortion analyzer, slowly increase audio generator output until relay starts to "click". This should occur between 10 and 20 volts on distortion analyzer.
 4. Switch oscillator and analyzer to channel "B" and repeat step 3.
 5. If relay operates outside of above range see TROUBLE ANALYSIS section of this manual.
1. HUM AND NOISE – HI-LEVEL
 1. DISCONNECT ALL input signals.
 2. Install 600 ohm shorting plugs in "AUX 1" "PHONO-1" and "PHONO-2" inputs of both channels.
 3. Connect audio band pass filter to channel "A" "REMOTE" speaker terminals.
 4. Connect distortion analyzer to output of band pass filter and set to 3 millivolt range (.003) volts.
 5. Turn Model 19 volume control to maximum. (full C.W.).
 6. Set Model 19 selector switch to "AUX 1" and read the "noise." It should be less than 1.8 mV.

7. Switch band pass filter and analyzer to channel "B" and read the "noise." It should be less than 1.8 mV.

J. HUM AND NOISE – LOW LEVEL (PHONO)

1. Use set up as described in hi level hum and noise steps 1 thru 4.
2. Set distortion analyzer to 30 millivolts range (.03 volts).
3. Set Model 19 selector switch to "PHONO."
4. Read the "noise" on the distortion analyzer. It should be less than 23 mV.
5. Press the "PHONO-2" button on the Model 19 and read the "noise." It should be less than 23 mV.
6. Move band pass filter and analyzer to channel "B" and release the "PHONO-2" pushbutton.
7. Repeat steps 4 and 5 for channel "B."

K. PRELIMINARY PROCEDURES – FM

1. Make the test setup shown in fig. 5 with instrument controls set in the following positions:

D.C. voltmeter – 0.5 volt range; zero set to center scale.

Audio generator – Frequency 400 Hz; output minimum.

Distortion analyzer – 1 volt range.

F.M. Stereo generator – Monaural; Ext. modulation; 1 K μ V output; 98 MHz.

Scope – Adjust as required for a usable trace.

Note: Make sure power consumption is normal before proceeding (see step 1 of section C).

2. Turn on Model 19 and allow to "warm up" for 5 to 10 minutes. Set controls as follows:

Volume – Minimum (full C.C.W.)

Selector switch – "F.M."

Speaker switch – OFF

Balance – Center

Tone controls – "Flat"

All push buttons except "MUTING OFF" – OUT (Released).

L. AUDIO OUTPUT

1. Connect audio generator to LEFT input on F.M. generator and adjust output level for 100% modulation (± 75 KHz deviation).
2. Connect distortion analyzer to either "TAPE OUTPUT" jack.
3. Tune Model 19 to generator output (98 MHz) and "fine tune" for zero (0) volts on the D.C. voltmeter.
4. Voltage indicated on the distortion analyzer should be between 0.65 and 1.00 volts. (Note: S/N 1001 to 1500 will read between 0.65 and 0.80 volts; S/N 1501 and up will read between 0.80 and 1.00 volts.)
5. Check other "TAPE OUTPUT" jack. It should read as above ± 0.5 dB.

M. HARMONIC DISTORTION

1. With the Model 19 setup and operating as above, set the distortion analyzer to read distortion and null.
2. The distortion should be less than 0.15% on BOTH "TAPE OUTPUT" jacks.
3. If not – See "DETECTOR (DISCRIMINATOR) adjustments".

N. HUM AND NOISE

1. Setup as above and reset distortion analyzer to SET LEVEL. Adjust the sensitivity of the analyzer for zero (0) dB reference level.
2. Switch the F.M. generator to C.W. operation and remove the audio oscillator from the left input.
3. Switch the distortion analyzer down scale to the -60 dB range. The hum and noise should read below -10 dB on this range, equivalent to -70 dB.

Note: At this very low level, the F.M. generators and the Model 19 tend to be slightly "microphonic". Make sure no loud noises such as fans, etc., or poor cable shielding give a false reading.

O. QUIETING SLOPE

1. Setup as above in section "N" and adjust the F.M. generator output to 10 μ V.

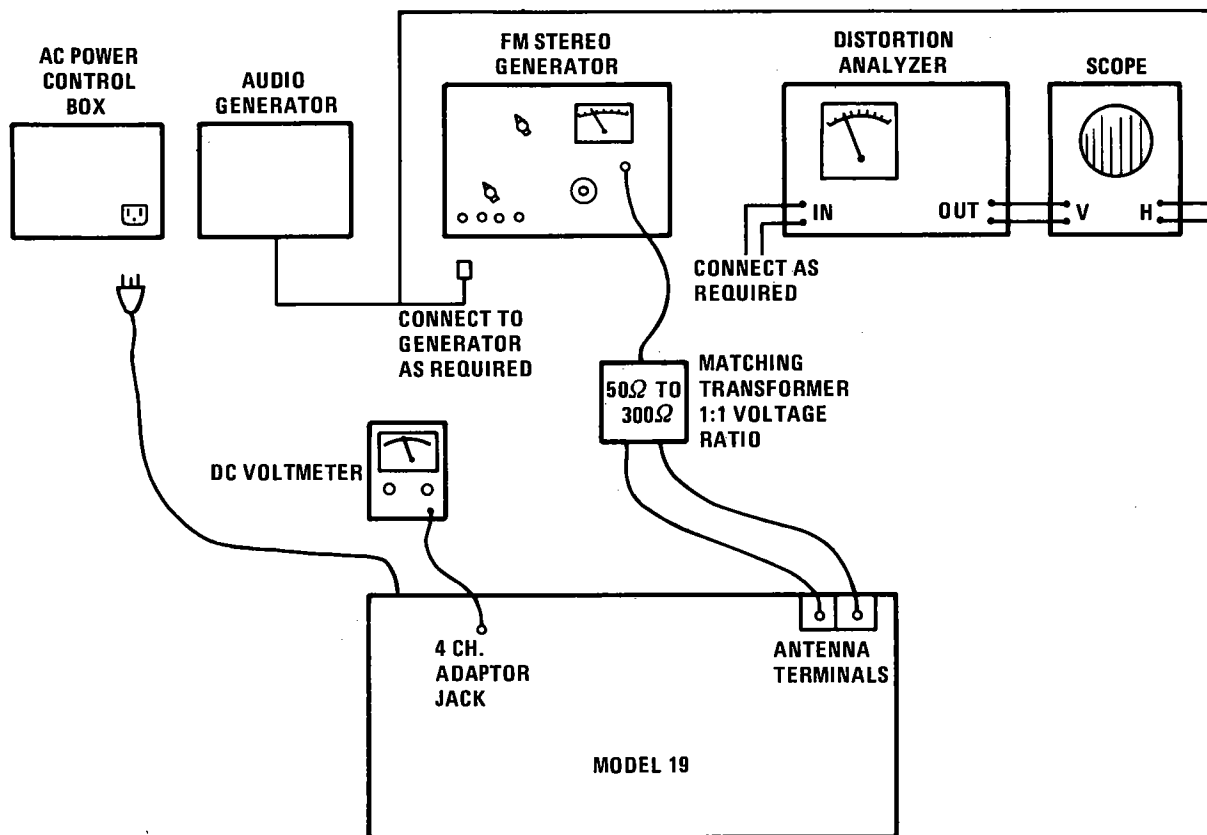

FIGURE 5. FM TEST SET-UP

2. Set the distortion analyzer as above and note the reading. It should be -2 dB (equivalent to -62 dB).
3. Set the distortion analyzer up one range to -50 dB.
4. Decrease F.M. generator output to 5 μ V.
5. The reading should be -5 dB (equivalent to -55 dB).

P. SENSITIVITY

1. Reconnect the audio generator to the LEFT input on the F.M. generator.
2. Set the F.M. generator to MONAURAL.
3. Set the distortion analyzer to SET LEVEL and adjust for 0 dB instead of full scale.
4. Switch the distortion analyzer to DISTORTION and switch down three (3) ranges to the -30 dB (3% F.S.) and null.
5. Reduce the generator output until a reading of 0 dB (-30 dB) is obtained.

6. The F.M. generator output should be 2.0 μ V or less. Note: If necessary the tuning of the Model 19 can be retouched slightly to meet the sensitivity spec. provided the indication on the D.C. voltmeter does not go beyond ± 0.2 volts

Q. SEPARATION

1. Set the F.M. generator to STEREO and adjust the 19 KHz pilot level to 10% modulation.
2. Connect the audio generator to the LEFT input on the F.M. generator.
3. Set the audio generator to 1 KHz and adjust the output level for 90% (plus 10% pilot equals 100%) modulation.
4. Connect the distortion analyzer to the channel "A" "TAPE OUTPUT" jack and adjust SET LEVEL for 0 dB.
5. Switch the distortion analyzer to channel "B" "TAPE OUTPUT" jack and note the reading. It should be 45 dB BELOW the 0 dB level obtained in step 4. Note: If necessary, the tuning of the Model 19 can be retouched slightly to meet the separation specs provided the indication on the D.C. voltmeter does not go beyond ± 0.2 volts.

6. Switch the audio generator to the RIGHT input on the F.M. generator and switch the distortion analyzer to the channel "A" "TAPE OUTPUT" jack. The reading should be -45 dB.
 7. Repeat steps 2 thru 6 changing the audio generator frequency to 15 KHz. The separation should be 30 dB.
 8. Repeat steps 2 thru 6 changing the audio generator frequency to 20 Hz. The separation should be 40 dB.
 9. If the above specs cannot be met, see the "MULTIPLEX alignment."
7. Switch the crystal oscillator to 108 MHz and retune the Model 19 to the 108 MHz "DOT." The reading should be zero (0) volts ± 0.4 volts.
 8. Switch the crystal oscillator to the 1 MHz harmonics and check each of the 1 MHz interval "DOTS" on the dial scale. The readings on the D.C. voltmeter should be zero (0) volts ± 0.4 volts.
 9. If the dial calibration does not fall within the above limits, see the "FRONT END ALIGNMENT" section of this manual.

Note: The above readings will only be as accurate as possible when the errors in frequency of the crystal oscillator are known and added (or subtracted) to the above.

R. FREQUENCY RESPONSE

1. Connect the audio generator to the LEFT input on the F.M. generator and set the frequency to 200 Hz.
2. Set the F.M. generator to MONAURAL.
3. Adjust the output of the audio generator for 100% modulation.
4. Set the distortion analyzer to SET LEVEL and adjust the sensitivity for a zero (0) dB reading.
5. Consult the chart on the "MULTIPLEX MATRIX BOARD alignment" page for various frequencies and output levels that should be obtained.
6. It should follow the 75 μ Sec. curve within ± 0.5 dB and the 50 μ Sec. (if so connected) curve within ± 1.0 dB.

S. DIAL CALIBRATION

1. Unsolder and disconnect the antenna input plug from J201 on the front end.
2. Connect the 88, 98, 108 and 1 MHz harmonic crystal oscillator to J201 on the front end.
3. Turn on the 98 MHz oscillator (others all OFF).
4. Tune the Model 19 to the 98 MHz "DOT" on the dial scale (cover it with the pointer).
5. The D.C. voltmeter should read zero (0) volts ± 0.4 volts (an approximate error of ± 20 KHz).
6. Switch the crystal oscillator to 88 MHz and retune the Model 19 to the 88 MHz "DOT." The reading should be zero (0) volts ± 0.4 volts.

TROUBLE ANALYSIS

The following section is designed to assist in locating troubles. The information given is to help in situations where problems may be difficult to isolate. Any field problems that arise will be covered through service bulletins (supplementary to this manual) that will be issued to all service stations. It is assumed that normal trouble-shooting techniques (*i.e.*, point-to-point signal tracing, oscilloscope analysis, etc.) will be used to isolate problems.

CAUTION: Because the driver and output stages are direct coupled, components may fail as a direct result of an initial component failure. If a shorted semiconductor is found, be sure to check the remaining driver and output components for short or open circuits before re-energizing the receiver. After replacement of any of these components, increase the Variac voltage slowly while monitoring the watt-meter as described in section C, step 1 of Performance Verification.

NOTE: Readjustment of the assembly containing the defective components and a performance verification is necessary following any repair.

SYMPTOM	PROBLEM
1. Excessive line consumption (70 watts or more)	<ul style="list-style-type: none"> a. Shorted or leaky: CR101 thru CR110; C101 thru C106; V901; Q1204 thru Q1207; C1211 and C1212; C418 and C419; C704 and C713; C522; Q1302 thru Q1305; C3, C4, C5, C8, C9. b. Open: R1301; Q1301; CR1203.
2. No or low line consumption or zero bias	<ul style="list-style-type: none"> a. Check line cord; fuse; power transformer. b. Open: CR101 thru CR110; R1304; Q1302 thru Q1305; CR1302 and CR1303; DS-2 thru DS-6; V901; Q1201 thru Q1207; CR1401. c. Shorted: CR1402, CR1403, C1402; CR1203; Q1208, Q1209; C1209; Q1301.
3. D.C. offset on output (small but out of spec.)	<ul style="list-style-type: none"> a. Mismatched Q1202 and Q1203. b. Open: R1212.
4. Excessive audio amp. distortion at low frequencies only.	<ul style="list-style-type: none"> a. C4 and C5 low in capacity. b. C1207 open or low in capacity. c. C1002, C1004, C1017, C1019 low in capacity.
5. Excessive audio amp. distortion at all frequencies	<ul style="list-style-type: none"> a. Q1001 thru Q1008 low beta, open or shorted. b. Open: C1009, C1012; C1207, C1209, C1202, C1204, C1206. c. Severe mismatch or low beta: Q1202 thru Q1206, Q1302 thru Q1305.

6. Excessive audio amp. distortion at high frequencies (10 KHz to 20 KHz)
 - a. Beta mismatch between: Q1202 and Q1203; Q1204 and Q1205; Q1304 and Q1305; Q1302 and Q1303.
 - b. Wire "dressing" in the area of: C4 and C5; tone board; power amp. board.
 - c. High beta (excessive) Q1001 thru Q1008.
 - d. Open: C1021 thru C1024; C1204, C1206, C1209, C1213, C1301, C1302; R1302, R1306, R1303, R1305.
 - e. High in value: R1301 and R1307.
7. Frequency response (high level)
 - a. Open, shorted or changed value: C1001, C1003, C1005, C1006, C1015, C1016, C1018, C1020.
8. Phono frequency response (20 Hz to 1 KHz) - gain to high towards 1 KHz
 - a. Open, or high in value: C809, C810, C807, C808.
9. Phono frequency response (20 Hz to 1 KHz) gain to low towards 20 Hz
 - a. Shorted or low in value: C809, C810; R820, R817, R826, R827.
10. Phono frequency response (1 KHz to 20 KHz) gain high at 20 KHz
 - a. Shorted or low in value: C813, C814; R831, R832, R830, R833.
11. Phono frequency response (1 KHz to 20 KHz) gain low at 20 KHz
 - a. Open or high in value: C813, C814; R831, R832, R830, R833.
12. Excessive phono distortion (all frequencies)
 - a. Open: R805, R809, R806, R810; Q803, Q804.
13. Excessive phono distortion (high frequencies)
 - a. Open or high in value: C805, C806, C811, C812.
 - b. Low beta: Q801 thru Q806.
14. Excessive short circuit current - power amp. output
 - a. Open: Q1208, Q1209; CR1203; R1226 thru R1231; CR1205, CR1206.
 - b. Shorted: Q1207 (E-C); R1301, R1307.
15. Relay function incorrect
 - a. Open, shorted or wrong value: C1208; R1232.
 - b. K1201 (relay) out of "adjustment" (readjust by "bending" the armature).
 - c. K1201 coil defective.
16. Excessive hum and noise - high level (aux etc.)
 - a. Open or low in capacity: C4, C5, C103, C102, C1002, C1004, C1019, C1017.
 - b. Open: CR110, CR111, shield ground; C1204, C1206; L1201; R1234; C1213, C1202, C1205, C1211, C1212; CR106 thru CR109.
 - c. E1 ground post loose.
 - d. Wire "dressing" in area of hi level inputs; at selector switch; on function switch board; in area of tone board.
 - e. Noisy: Q1001 thru Q1008.

- f. S/N 1001 to S/N 1896 - C1404 wrong value.
 - g. Mismatch of Q1202 and Q1203.
 - h. Q1202, Q1203 - low beta.
17. Excessive hum and noise - phono
- a. Open: C3, C805, C806, C811, C812; input cable ground.
 - b. Dirty phono 1-2 switch.
 - c. Loose E1 ground post.
 - d. Wire "dressing" in area of: phono board input terminals; phono jacks at rear panel; function switch board.
 - e. Noisy: Q801 thru Q806.
18. Low audio output - FM
- a. Open: C709; CR701, CR702; C714, C628, C620, C621, C622, C629; Z601, Z602; Q503, Q601 thru Q604, Q501, Q508; CR601 thru CR604.
 - b. Shorted: Q701; C714; Q601 thru Q604, Q508, Q501, Q504; Z501; Q505; C606, C607, C612, C613, C618, C619, C625, C626.
 - c. Defective (incorrectly wound or broken) L703.
19. Excessive distortion - FM
- a. Low beta: Q701, Q501.
 - b. Improper matching of Q601 and Q602.
 - c. Defective (incorrectly wound or broken) L703.
 - d. Incorrect "FRONT END" or "I.F." alignment - RETURN TO FACTORY.
 - e. C707 incorrect value.
- Note: The distortion can be measured at the "4 CHANNEL ADAPTOR JACK," if it is less than 0.2%, the problem lies in the multiplex section.
20. Excessive hum and noise - FM
- a. Open or low in capacity: C3, C102 thru C104, C522.
 - b. Noisy: Q201, Q301 thru Q304, Q901, Q904, Q601 thru Q604, Q501, Q508.
 - c. Open: L502, L504, L601 thru L604; C501, C509, C610, C611, C606, C607, C613, C612, C618, C619, C624, C623, C625, C626; C7, C6.
 - d. Broken shield ground wire.
 - e. Excessive microphonics in FRONT END - RETURN TO FACTORY for replacement.
 - f. Dirty antenna attenuator switch.
 - g. "Phasing" of L601 thru L604.
21. Poor quieting slope and sensitivity.
- a. Open: Q201; C305, C318, C330, C342, C401, C411, C422, C431; CR403, CR404, CR407, CR408, CR411, CR412, CR413, CR414.

- b. Low gain: Q201, Q301 thru Q304, Q401 thru Q404.
 - c. Improper FRONT END or I.F. alignment - RETURN TO FACTORY.
 - d. Dirty antenna attenuator switch.
 - e. Defective T1 - balun input transformer.
 - f. Shorted R.F. cables.
22. Poor multiplex separation.
- a. Open: L503; T501; CR601 thru CR604; C509, C601 thru C605, C608, C609, C615 thru C617.
 - b. Shorted: L503; T501; CR601 thru CR604; C509, C601 thru C605, C608, C609, C615 thru C617.
 - c. Mismatch of Q601 and Q602.
 - d. I.F. out of alignment - RETURN TO FACTORY.
23. Frequency response - F.M. (Response on high side of curve.)
- a. Low in capacity or open: C612, C613, C618, C619, C625, C626, C614.
 - b. L601 thru L604 - wrong value or open.
 - c. R615 and R616 low in value.
 - d. High in capacity or shorted: C610, C611, C613, C614.
24. Frequency response - F.M. (Response on low side of curve.)
- a. High in capacity or shorted: C612, C613, C615, C618, C619, C625, C626.
 - b. L601 thru L604 wrong value or shorted.
 - c. R615 and R616 high in value.
 - d. Low in capacity or open: C603, C617, C610, C611, C623, C624, C621, C622, C628, C629.
25. Improper muting action when tuning off of station ONLY.
- a. Open or shorted: Q502; CR501, CR502.
 - b. Shorted only: C519, C520.
26. Incorrect time delay - (too short)
- a. Low in capacity or open: C1402.
 - b. Shorted: CR1402, CR1403; C1404.
27. Incorrect time delay - (too long)
- a. Open: R1405, R1406.
 - b. Shorted: C1402.
28. Scope trace won't center
- a. Incorrect I_{dss} of Q901 and/or Q904.
 - b. Shorted: Q901 thru Q906; C901, C902, C1, C2.
 - c. Open: Q901 thru Q906; R9, R10
29. Stereo indicator doesn't light
- a. Open: DS-1; Q1401; R1407; Q509, Q605.
 - b. Shorted: Q606; C627, C630, C516.

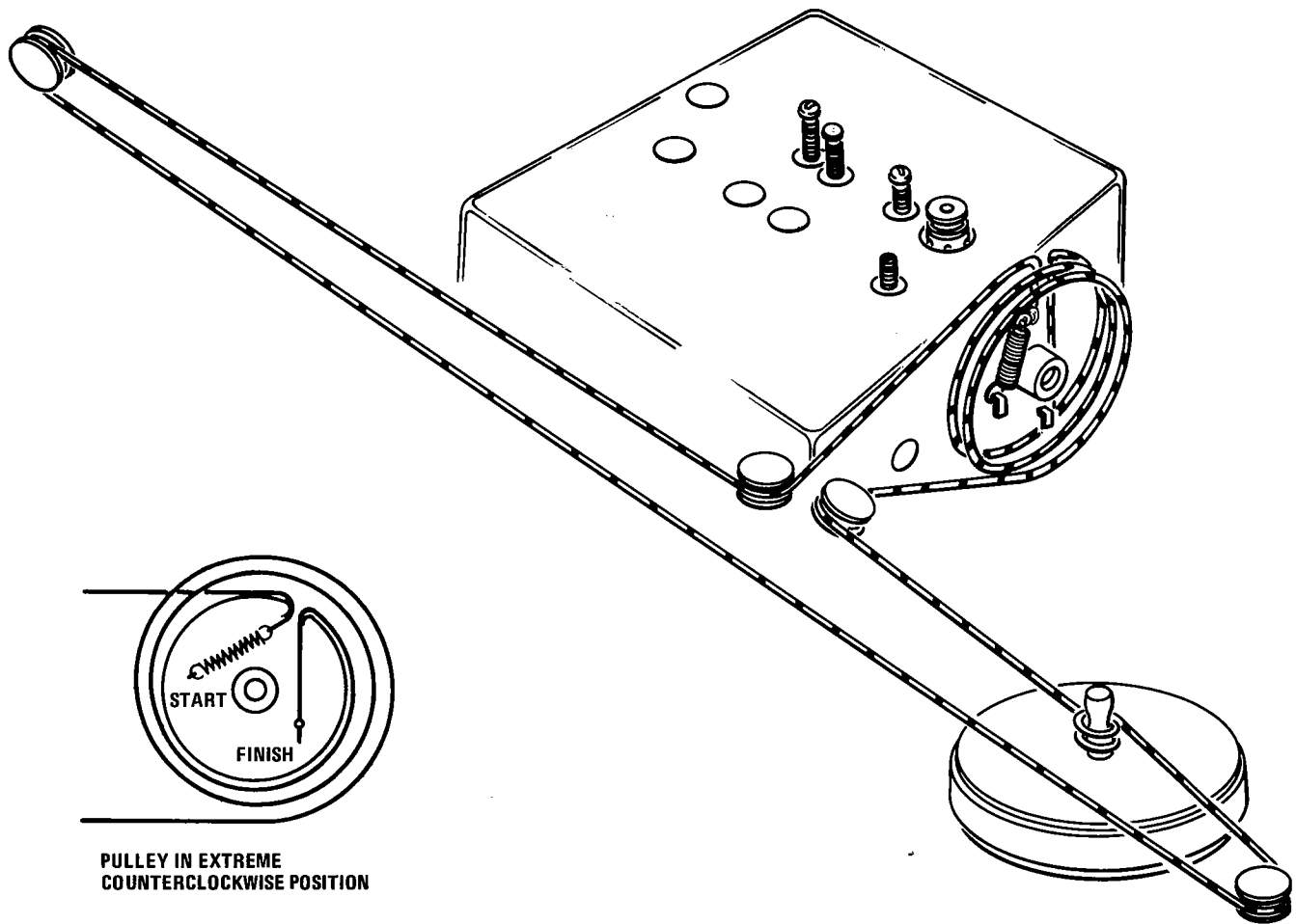

FIGURE 6 – DIAL CORD STRINGING DIAGRAM

NOTE: USE ONLY DIAL CORD REFERRED TO IN PARTS LIST (SEE PAGE 88); DO NOT SUBSTITUTE. OTHERWISE IMPROPER OPERATION WILL RESULT.

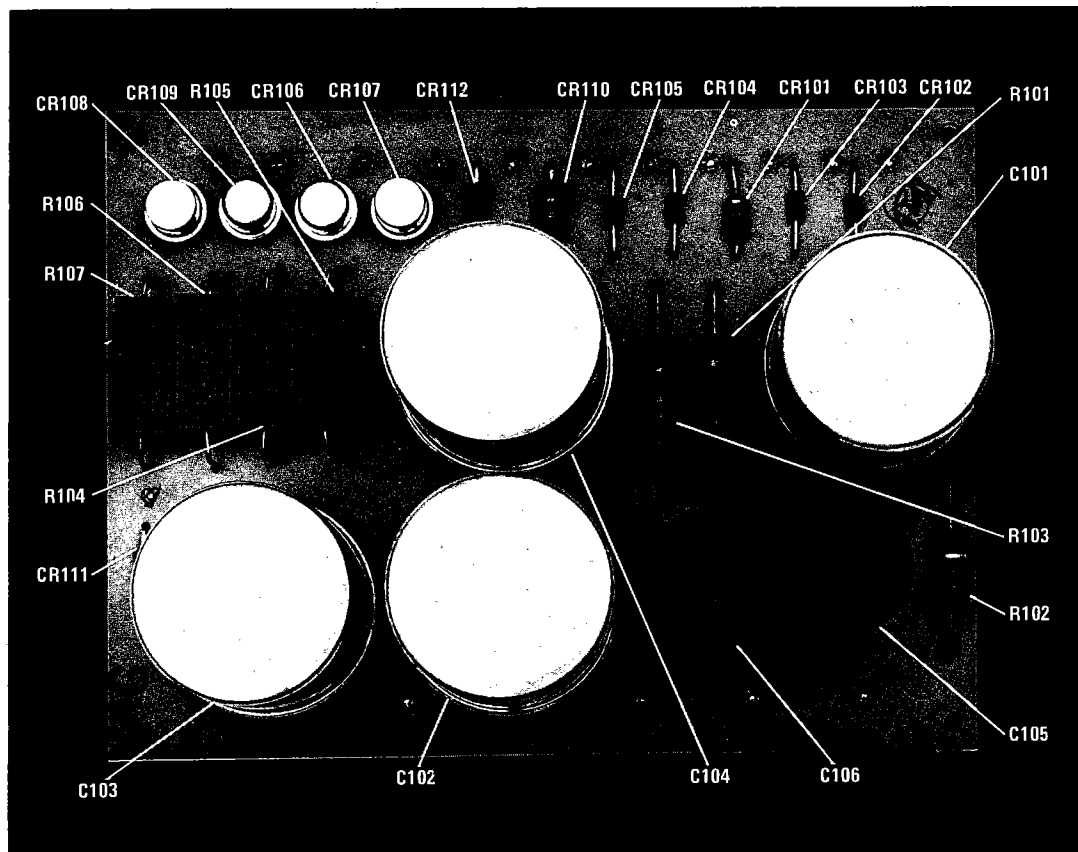

FIGURE 7A – POWER SUPPLY COMPONENT DIAGRAM

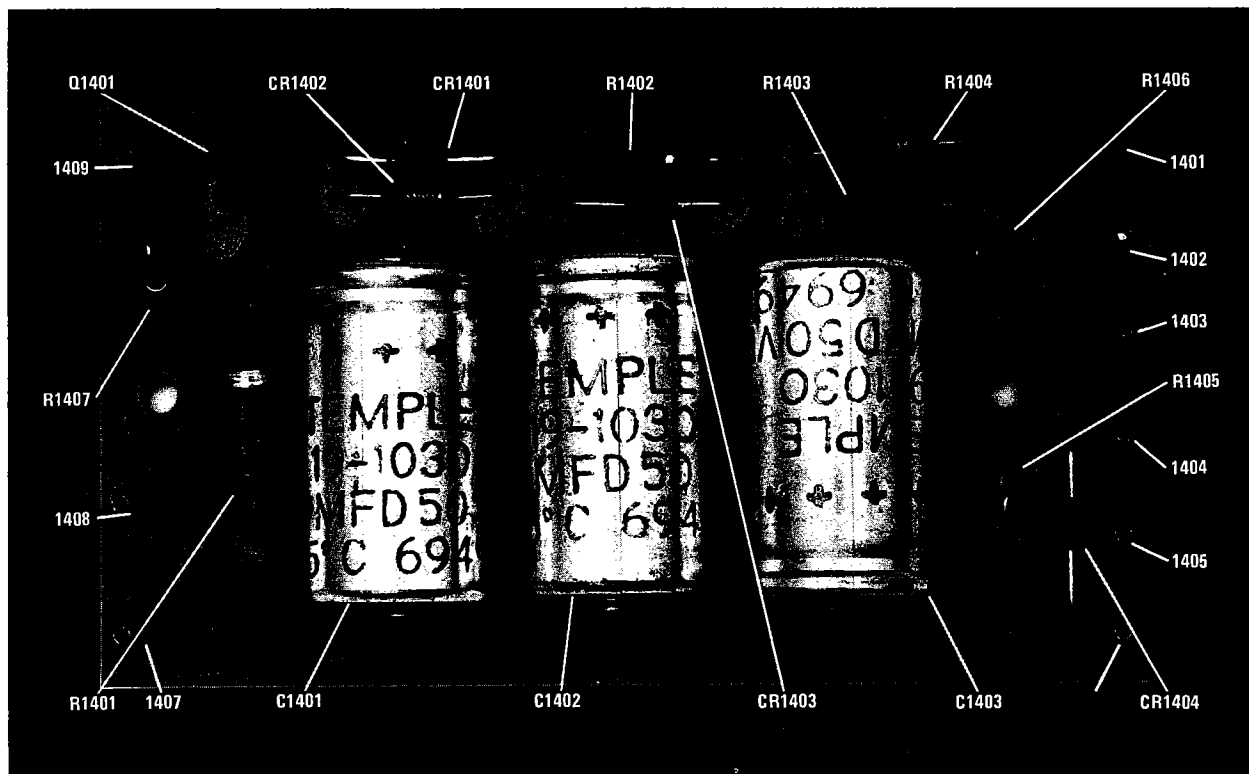

FIGURE 8A – TIME DELAY COMPONENT DIAGRAM

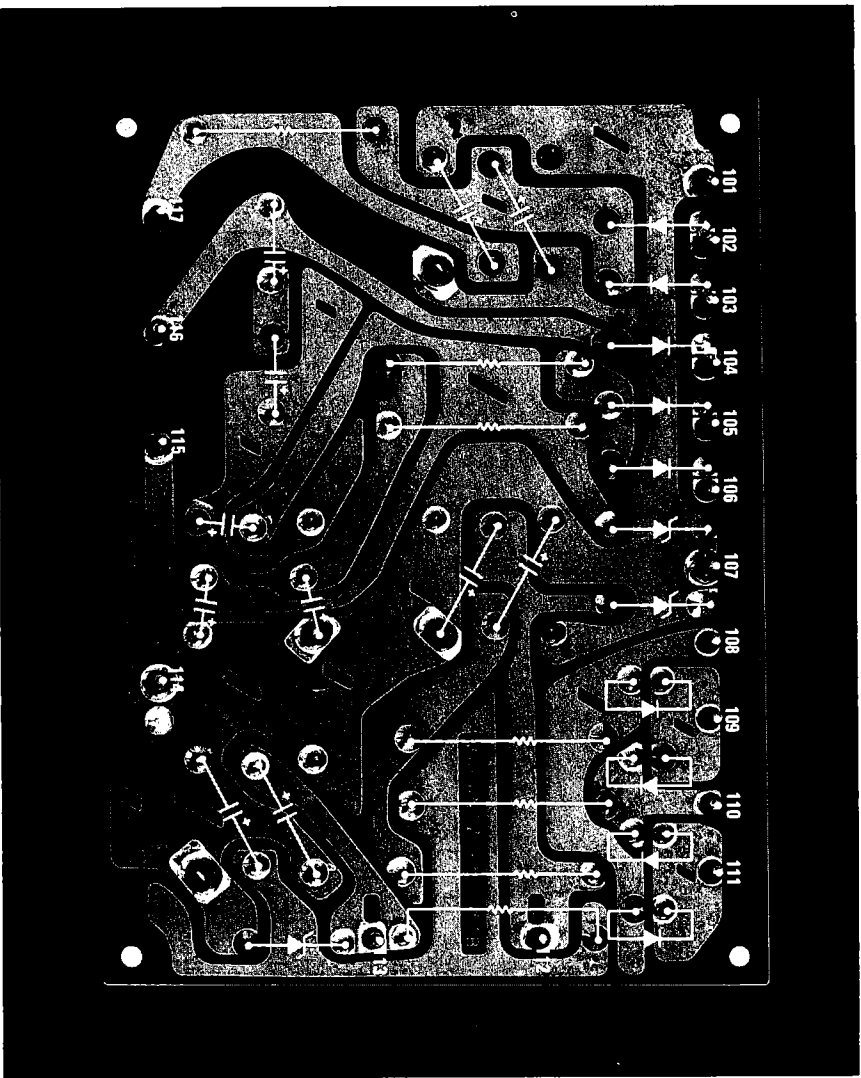

FIGURE 7B - POWER SUPPLY CONDUCTOR DIAGRAM

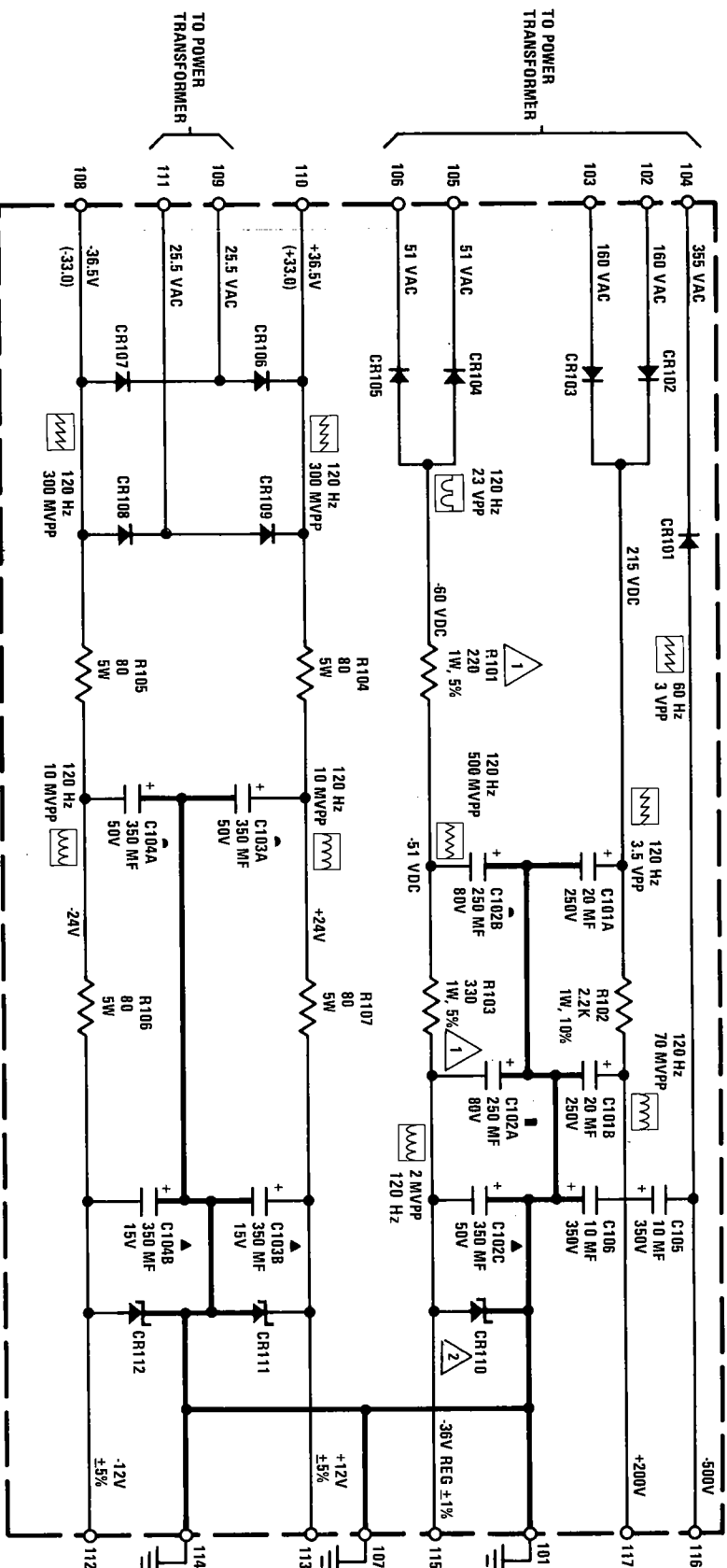

FIGURE 7C - POWER SUPPLY SCHEMATIC DIAGRAM

▲ R101 AND R103 WERE 430Ω 2 WATTS PRIOR TO S/N 1501.
 ▲ CR110 WAS P/N 335-1013 PRIOR TO S/N 1501.

▲ AC WAVEFORMS SHOWN WERE TAKEN WITH A SCOPE HAVING A 1 MEGOHM INPUT IMPEDANCE SHUNTED BY 47 pF. GROUND CONNECTION: PIN #114

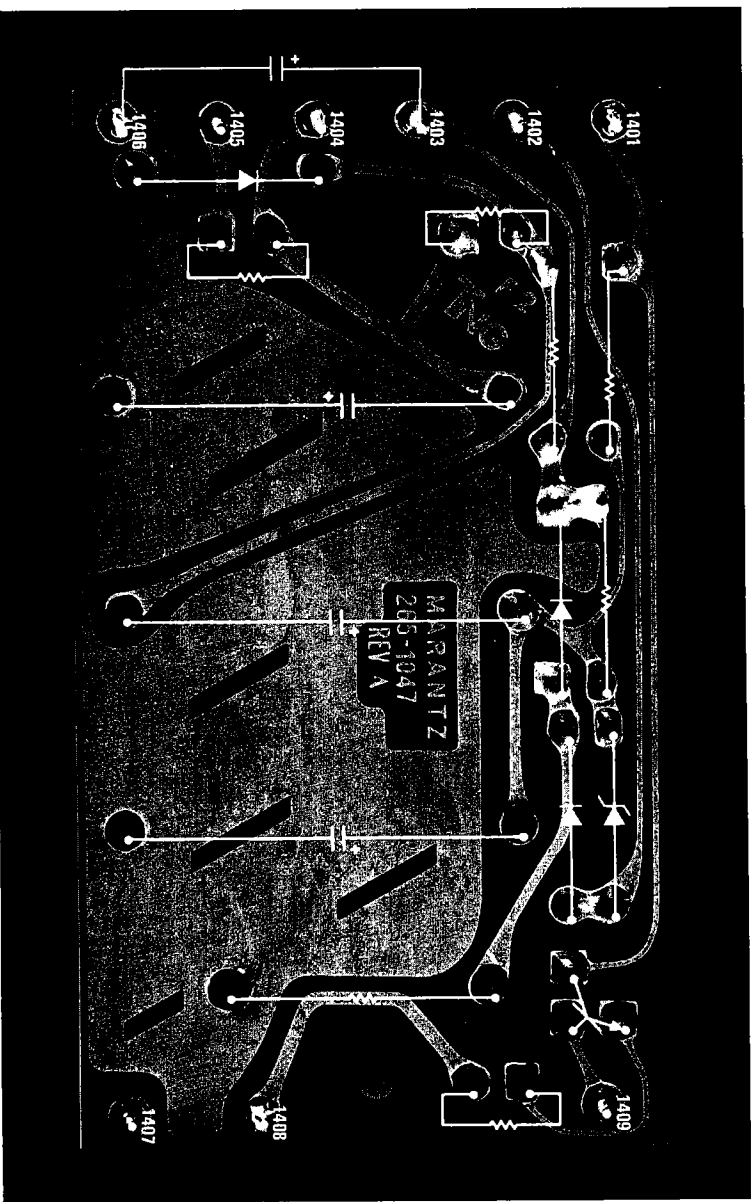
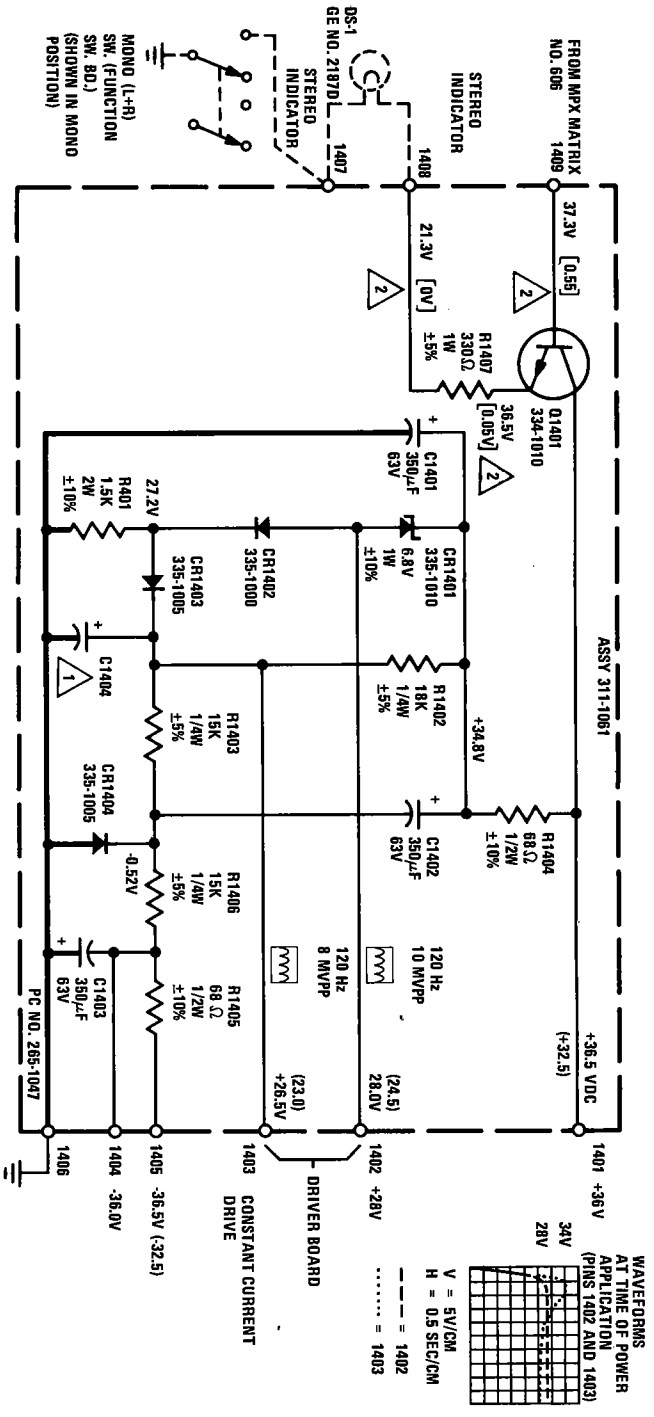

FIGURE 8B - TIME DELAY CONDUCTOR DIAGRAM

1 ALL CAPACITORS ARE 250V.
 AC WAVEFORMS SHOWN WERE TAKEN WITH A SCOPE HAVING A 1 MEGOHM INPUT IMPEDANCE SHUNTED BY 47 pF.
 GROUND CONNECTION: PIN #1406 TAKEN WITH ALL PUSHBUTTONS OUT.

FIGURE 8C - TIME DELAY SCHEMATIC DIAGRAM



UNLESS OTHERWISE NOTED:
 ALL RESISTORS ARE IN OHMS 1/2W 5%
 ALL CAPACITORS IN DECIMALS AND LESS THAN 1 ARE μF.
 ALL OTHER CAPACITORS ARE pF
 ALL INDUCTORS ARE IN μH

▲ ALL VOLTAGES SHOWN ARE ±10% (UNLESS OTHERWISE NOTED) TAKEN WITH A DC VTVM HAVING AN INPUT IMPEDANCE OF 200 MEG-OHMS AND AN AC VTVM HAVING AN INPUT IMPEDANCE OF 1 MEGOHM. LINE VOLTAGE EQUALS 120 VAC AT 60 HZ.
 ▲ C1404 TO BE SELECTED IN TEST PRIOR TO S/N 1896 (DELETED IN S/N 1896).
 ▲ VOLTAGES IN BRACKETS ARE STEREO INDICATOR "OFF" WITH MONO STEREO SWITCH IN STEREO POSITION AND SELECTOR SWITCH IN "FM" POSITION.
 ▲ VOLTAGES IN PARENTHESES ARE WITH BOTH CHANNELS DRIVER AT 1 KHZ @ 50W RMS INTO AN 8 OHM LOAD.

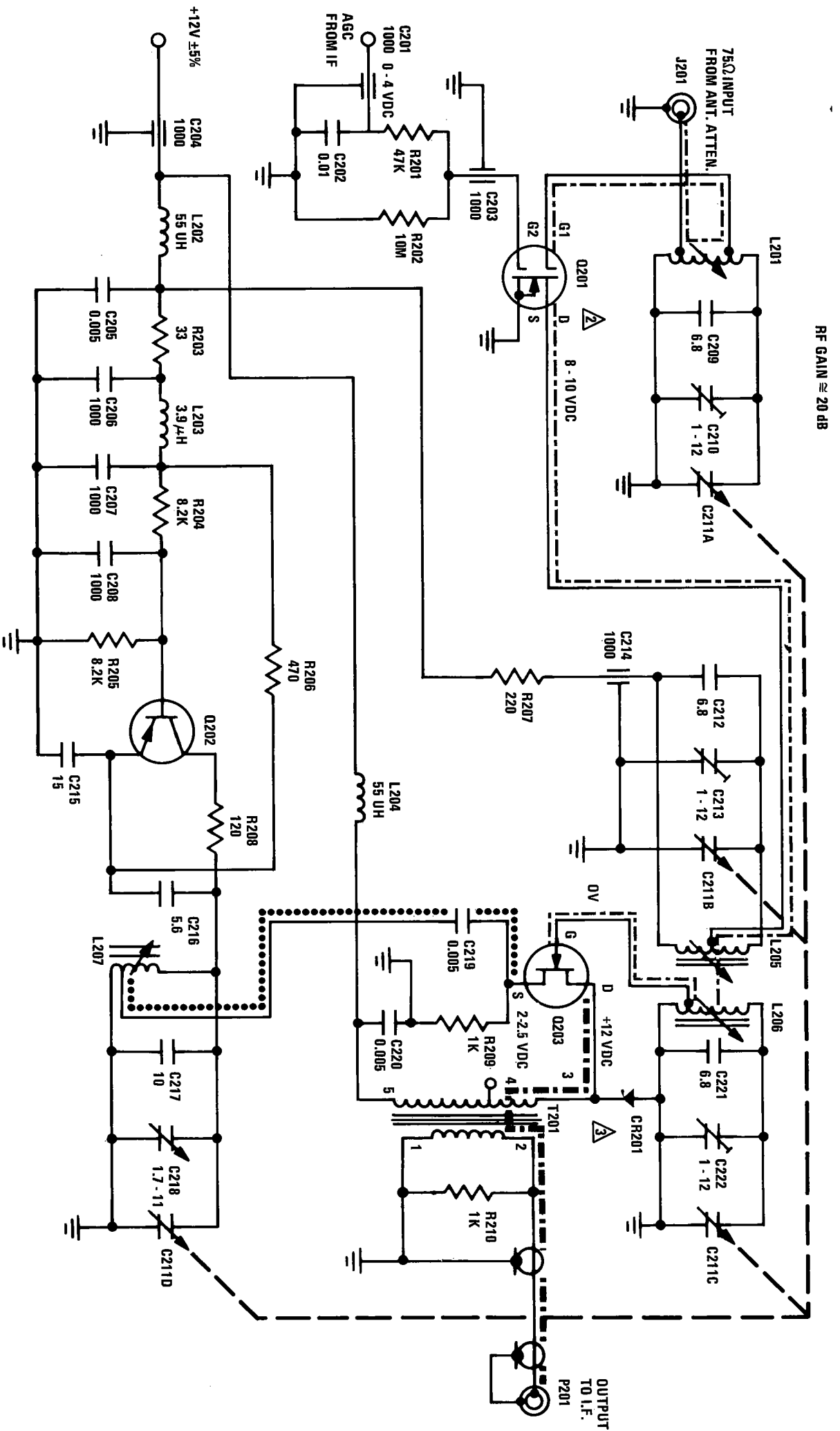

FIGURE 9A - FRONT END SCHEMATIC DIAGRAM

ALL VOLTAGES SHOWN ARE +10% (UNLESS OTHERWISE NOTED) TAKEN WITH A DC VTVM HAVING AN INPUT IMPEDANCE OF 200 MEG-OHMS AND AN AC VTVM HAVING AN INPUT IMPEDANCE OF 1 MEGOHM. LINE VOLTAGE EQUALS 120 VAC AT 60 Hz.

UNLESS OTHERWISE NOTED:
 ALL RESISTORS ARE IN OHMS $\frac{1}{2}$ W 5%
 ALL CAPACITORS IN DECIMALS AND LESS THAN 1 ARE μ F,
 ALL OTHER CAPACITORS ARE pF
 *ALL INDUCTORS ARE IN μ H

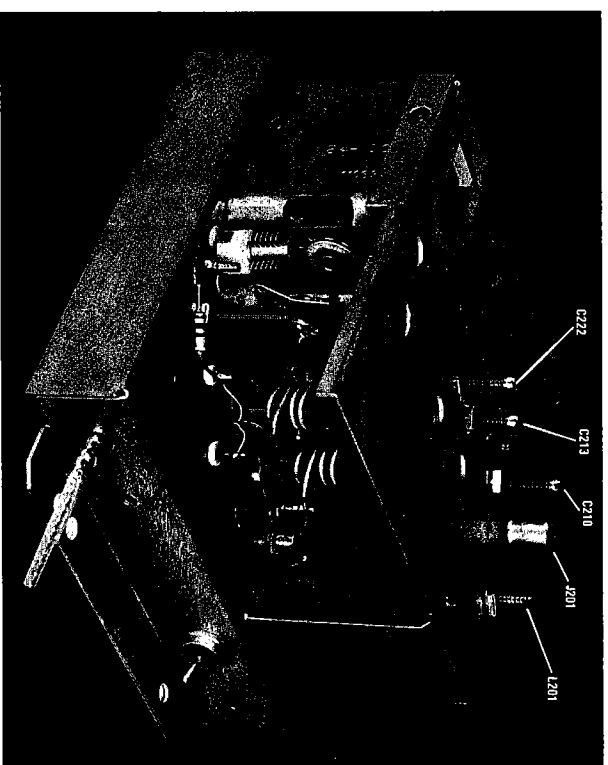

FIGURE 9B - FRONT END OVERVIEW

NOTE:

△ R209 AND R210 WERE 4.7K AND 470Ω RESPECTIVELY PRIOR TO S/N 1697.

△ Q201 WAS P/N 334-1038 PRIOR TO S/N 1697.
 △ CR201 WAS NOT USED PRIOR TO S/N 1697.

- LOCAL OSCILLATOR SIGNAL PATH
- RF PRIMARY SIGNAL PATH
- ■ ■ ■ ■ 10.7 MHz OUTPUT

FRONT END ADJUSTMENTS

The Model 19 front end is a "state-of-the-art" assembly which has limited field serviceability. In the event the front end proves defective, normal trouble shooting methods may be used to locate the defective component. It should be noted, however, that during trouble shooting and especially during parts replacement, that **EXTREME ATTENTION** be given to seemingly small (but often times very important) details. Such "small" things as the size and placement of certain solder joints, the placement and shape of leads and the position of one part relative to another, could degrade items not normally measured at service facilities; such as image rejection, spurious responses, etc.

In the event field parts replacement is done, the receiver should be carefully checked for performance to determine if realignment is necessary. **DO NOT** attempt alignment yourself. Return the front end to the factory along with the dial strip where it will be realigned and matched to the "custom drilled" dial strip.

If "dial tracking" only is off, determine if the error is evenly distributed across the dial, *i.e.*, the dial pointer misses the 1 MHz dial scale marks by the same distance at each mark. If so "break loose" the dial pointer **CAREFULLY** from the dial string (it's cemented in place) and slide it down the string. When error is corrected, re-cement it to the dial string with "EASTMAN" No. 910, "LOCTITE" No. 404 or equivalent.

If the error is not the same at all places on the dial but is greater at the lower or upper end, slight retouching of L207 (for low end of band) and C218 (for high end of band) should be tried. Note: Although L207 will effect the "low end" of the band the most, etc., there is an interaction between L207 and C218 that must be corrected for by trial and error.

If it is found that a large mistracking exists, return to factory.

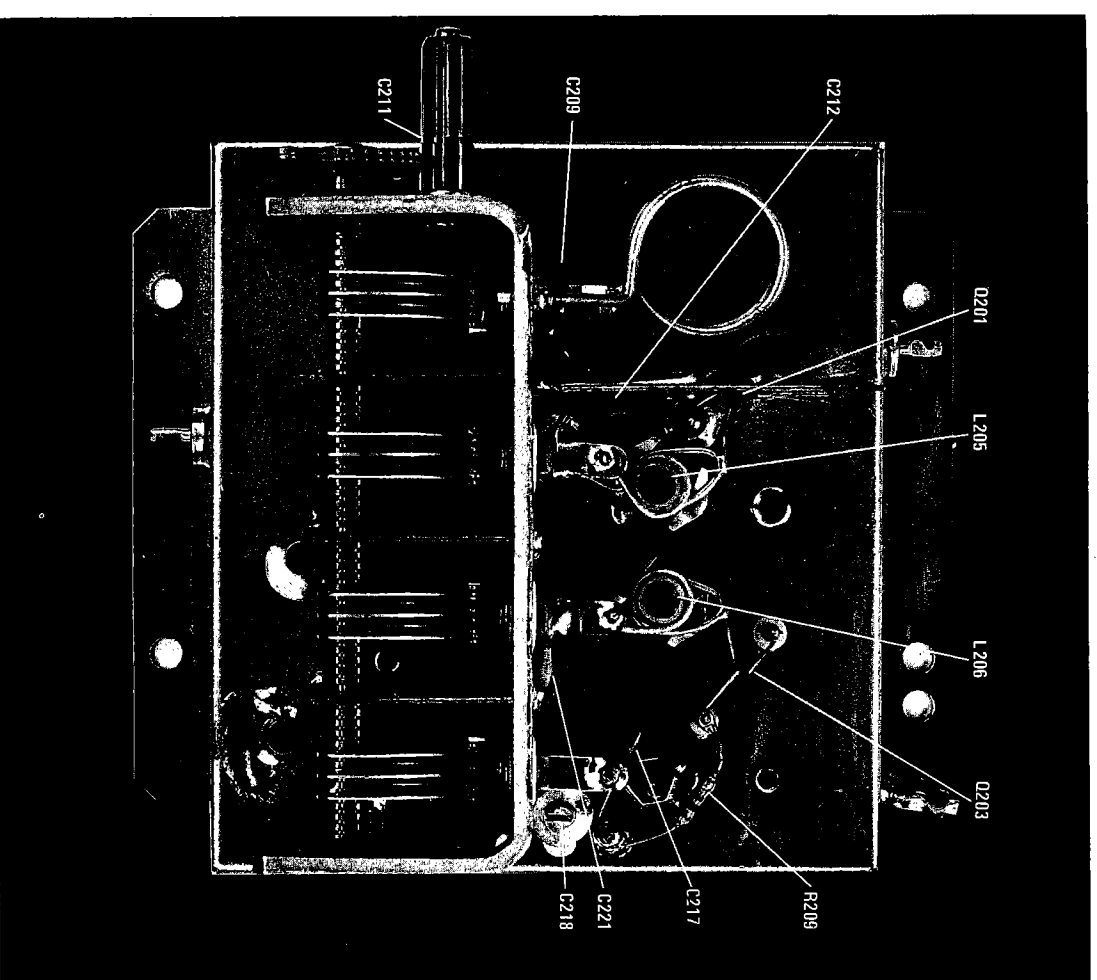

FIGURE 9C - FRONT END TOP VIEW DIAGRAM

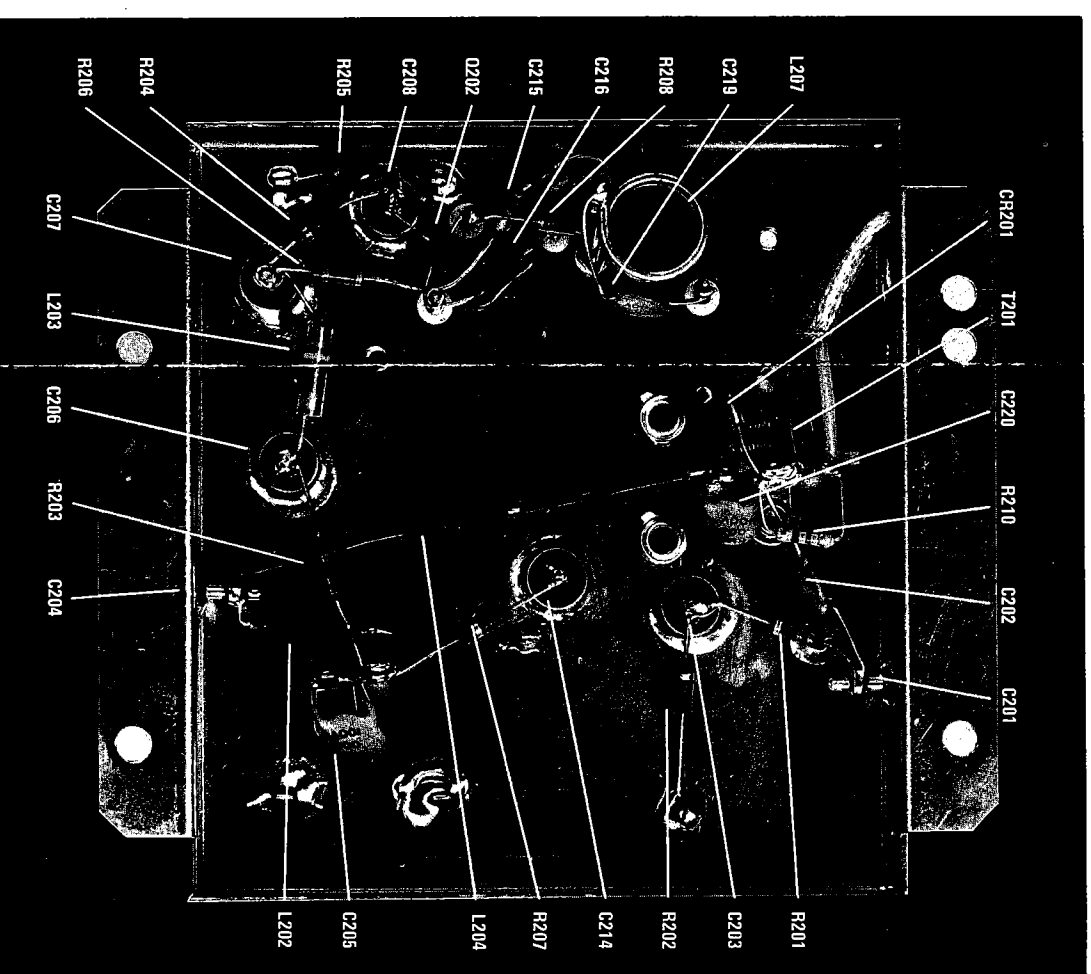
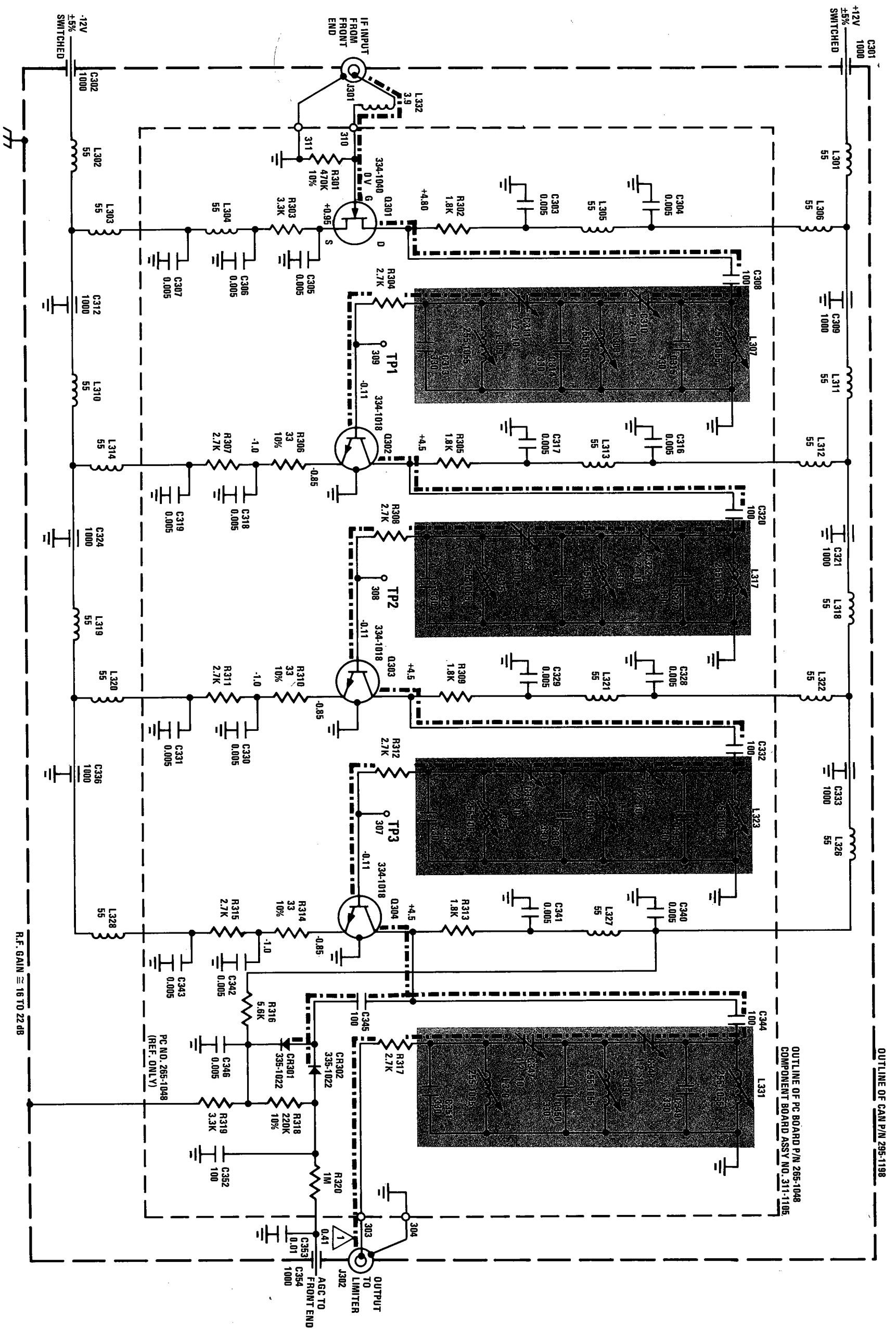

FIGURE 9D - FRONT END BOTTOM VIEW DIAGRAM

THE PARTS LIST FOR THIS UNIT IS LOCATED ON PAGE 70.



OUTLINE OF CAN P/N 295-1198

OUTLINE OF PC BOARD P/N 265-1048
COMPONENT BOARD ASSY NO. 311-110E

R.F. GAIN \approx 16 TO 22 DB

----- 10.7 MHz SIGNAL PATH
 ▽ AGC VOLTAGE VARIES WITH SIGNAL STRENGTH.

FIGURE 10A - I.F. SCHEMATIC DIAGRAM

ALL VOLTAGES SHOWN ARE \pm 10% (UNLESS OTHERWISE NOTED) TAKEN WITH A DC VTVM HAVING AN INPUT IMPEDANCE OF 200 MEG-OHMS AND AN AC VTVM HAVING AN INPUT IMPEDANCE OF 1 MEGOHM; LINE VOLTAGE EQUALS 120 VAC AT 60 Hz.

UNLESS OTHERWISE NOTED:
 ALL RESISTORS ARE IN OHMS $\frac{1}{4}$ W 5%
 ALL CAPACITORS IN DECIMALS AND LESS THAN 1 ARE μ F
 ALL OTHER CAPACITORS ARE pF
 *ALL INDUCTORS ARE IN μ H

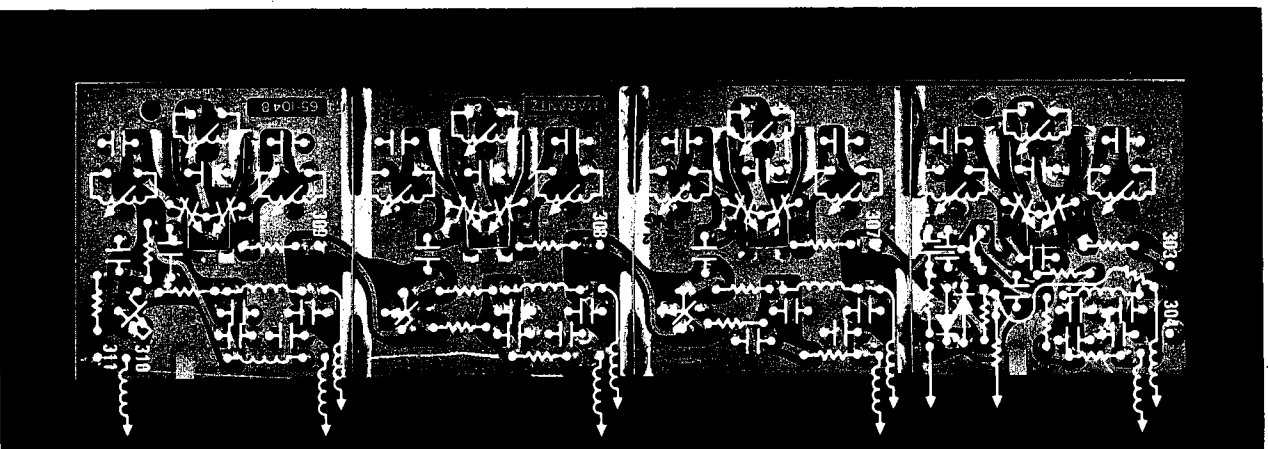

FIGURE 10B - I.F. CONDUCTOR DIAGRAM

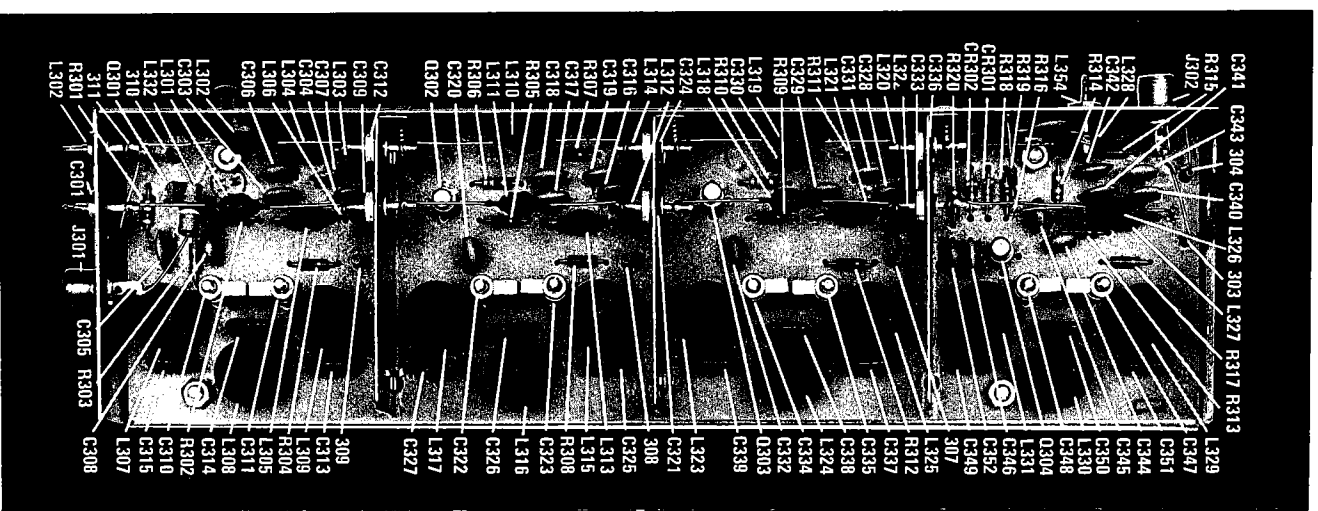

FIGURE 10C - I.F. COMPONENT DIAGRAM

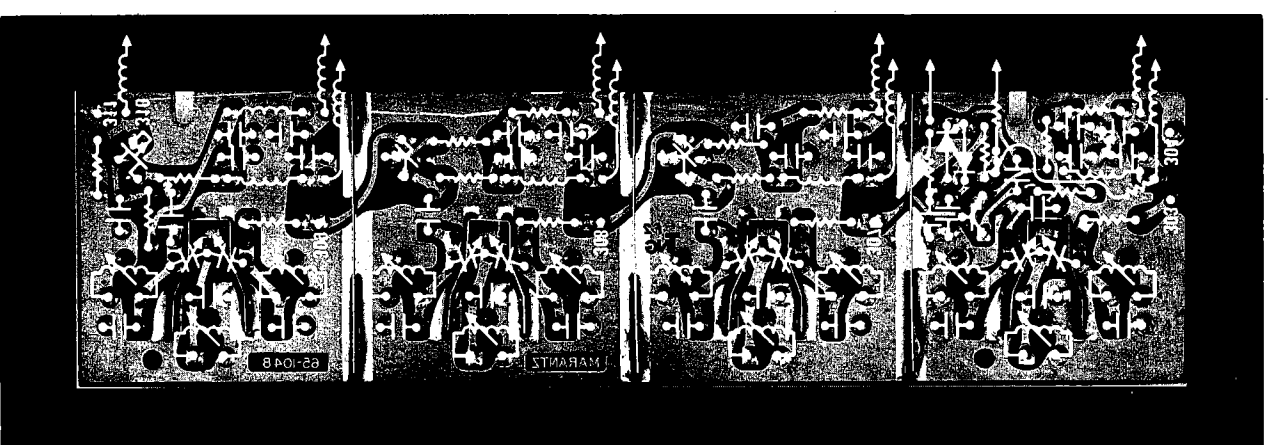

FIGURE 10D - I.F. CONDUCTOR PATTERN
DIAGRAM (AS VIEWED
FROM THE COMPONENT
SIDE OF BOARD)

IF ALIGNMENT

As of the publication date of this manual, no practical methods of field I.F. alignment have been devised. Therefore a portion of this page will remain blank to allow you to attach any possible future addendums which contain I.F. alignment information.

Note: Most I.F. components not directly in the actual "filter" section may be replaced (with great care) without causing need for realignment. "Filter" sections are the shaded areas on the schematic.

THE PARTS LIST FOR THIS UNIT IS LOCATED ON
PAGE 71.

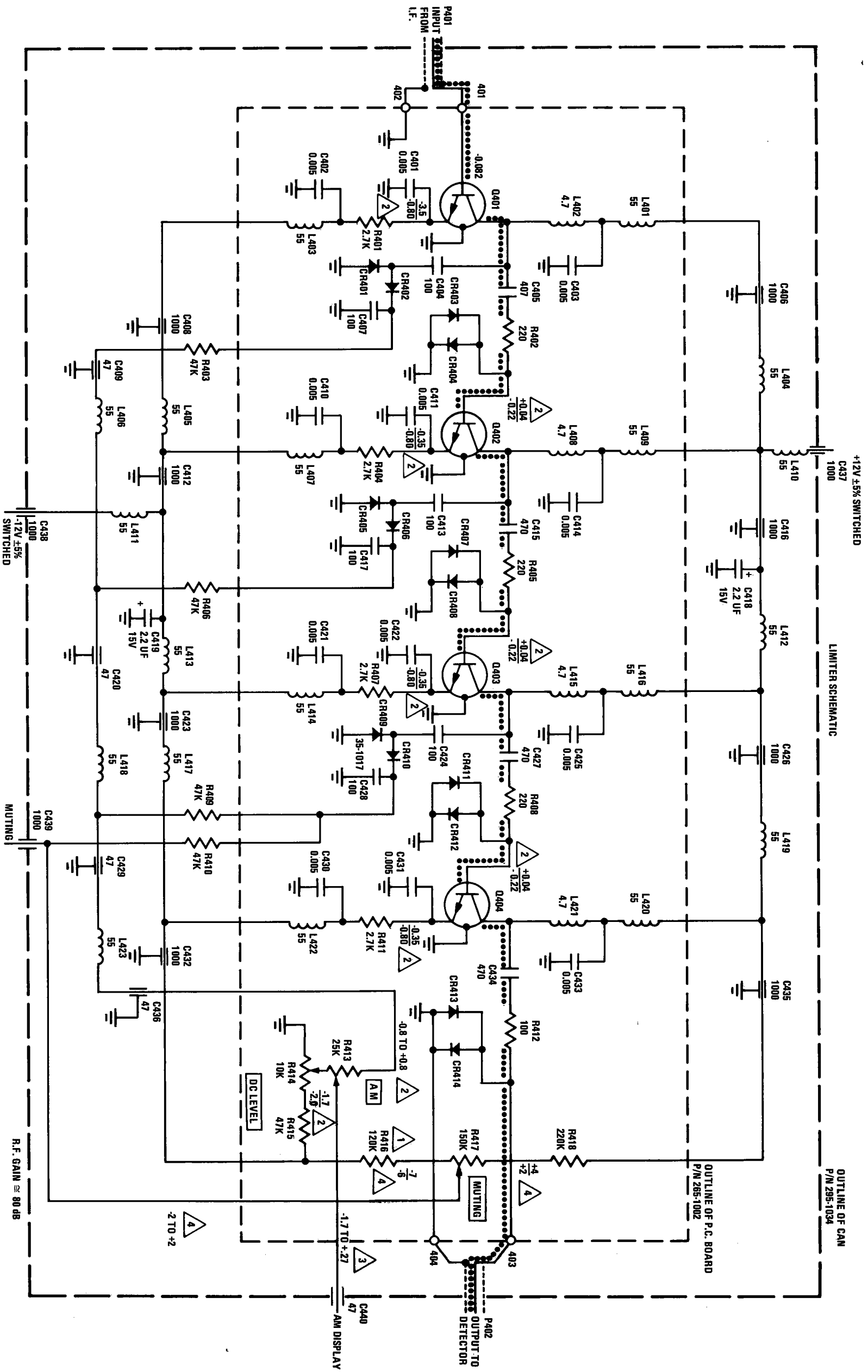

- 1 R416 MAY BE 220K PRIOR TO S/N 1386. 10.7 MHZ SIGNAL PATH (PRIMARY)
- 2 RANGE OF VOLTAGE AT THESE POINTS DETERMINED BY SIGNAL STRENGTH.
- 3 VOLTAGES SHOW VARY WITH SETTINGS OF AM DISPLAY AND DC LEVEL POTS.
- 4 VOLTAGES SHOWN VARY WITH SETTING OF MUTING POT.

ALL VOLTAGES SHOWN ARE ±10% (UNLESS OTHERWISE NOTED) TAKEN WITH A DC VTVM HAVING AN INPUT IMPEDANCE OF 200 MEG-OHMS AND AN AC VTVM HAVING AN INPUT IMPEDANCE OF 1 MEGOHM; LINE VOLTAGE EQUALS 120 VAC AT 60 HZ.

UNLESS OTHERWISE NOTED:
 ALL RESISTORS ARE IN OHMS 1/4W 5%
 ALL CAPACITORS IN DECIMALS AND LESS THAN 1 ARE μF
 ALL OTHER CAPACITORS ARE PF
 *ALL INDUCTORS ARE IN μH

THE PARTS LIST FOR THIS UNIT IS LOCATED ON PAGE 73.

FIGURE 11A - LIMITER SCHEMATIC DIAGRAM

LIMITER ADJUSTMENTS

Note: Before proceeding with the adjustments contained in the limiter, check or do the adjustments for the detector, scope board and multiplex.

1. Connect F.M. Generator to "ANTENNA" terminals.
2. Connect distortion analyzer to either channel "TAPE OUT" jack.
3. Set analyzer to 1 volt range.
4. Set F.M. generator to "monaural" and adjust for 100% modulation, at 400 Hz 1 K μ V. output.
5. Set Model 19 controls as follows: selector "FM", volume minimum (full C.C.W.); ALL pushbuttons OUT. Note: Be sure antenna attenuator is in the "out" position.
6. "Fine tune" Model 19 to generator frequency.
7. Lower generator output to 4 μ V.
8. Adjust the "MUTING POT" (R417) until audio just goes off.
9. Check by reducing generator output to minimum then SLOWLY increase output until audio comes on. This should occur at 6 to 8 μ V. If not, re-adjust "MUTING POT" slightly to achieve 6 to 8 μ V. demuting.
10. Press the "muting off" pushbutton.
11. Reduce the generator output to 1 uv.
12. Adjust the "D.C. LEVEL" pot (R414) until the horizontal line (with some noise "grass" riding on it) is just touching the bottom of the screen.
13. Increase generator output to 100 K μ V. (or maximum - whichever is less). CAUTION, HIGH VOLTAGE IS ON SCOPE BOARD NEXT TO LIMITER.
14. Adjust "A.M. DISPLAY" pot (R413) until the horizontal trace just touches the tip of the upper arrow on the scope reticle. Note: Some interaction occurs between R413 and R414. Repeat steps 9 thru 12 until no further adjustment is necessary.

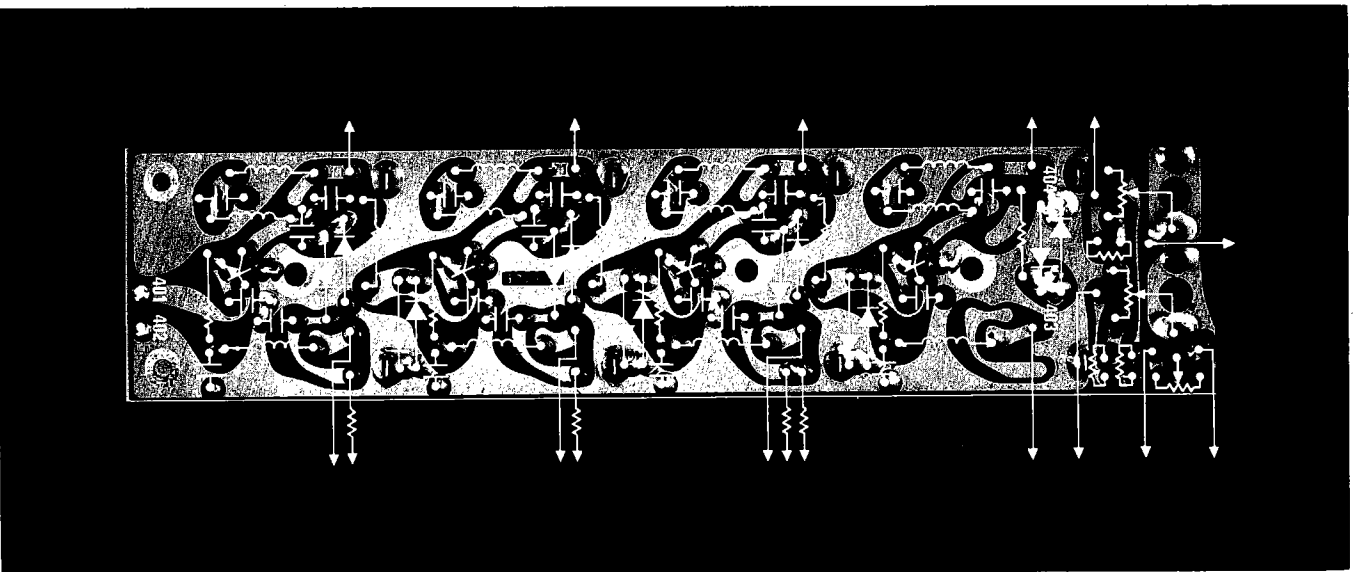

FIGURE 11B - LIMITER CONDUCTOR DIAGRAM

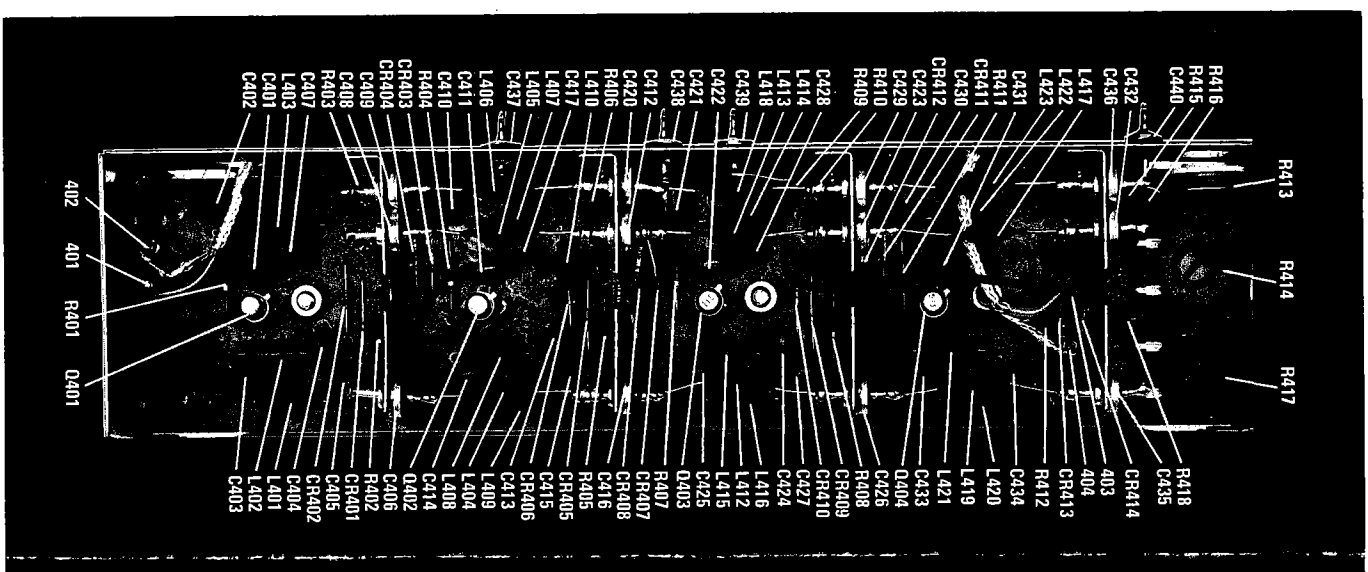

FIGURE 11C - LIMITER COMPONENT DIAGRAM

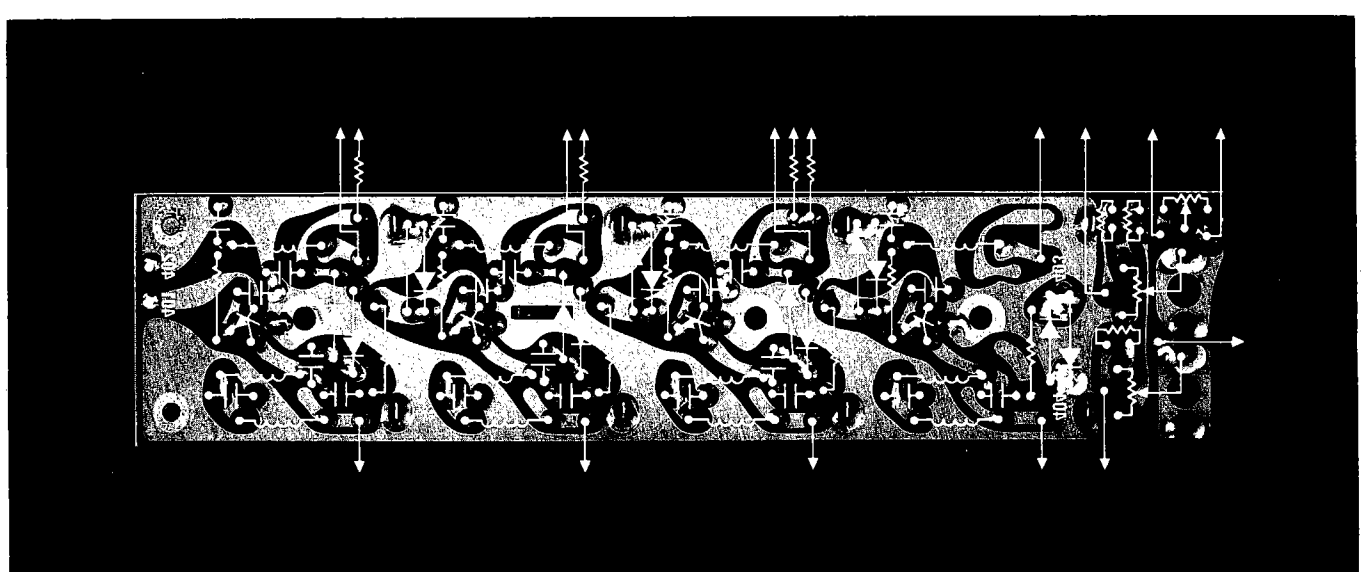
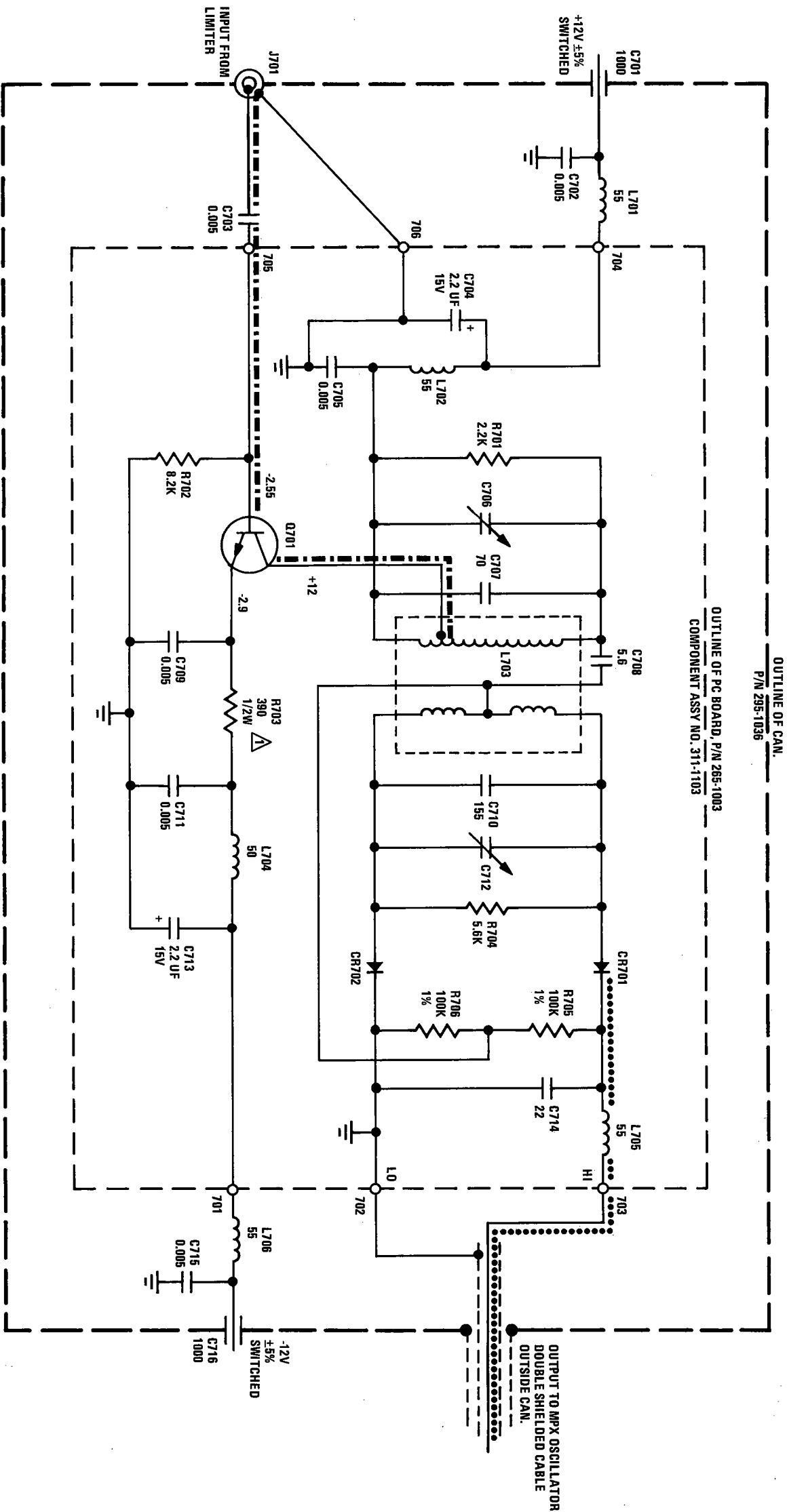

FIGURE 11D - LIMITER CONDUCTOR DIAGRAM (AS VIEWED FROM THE COMPONENT SIDE OF BOARD)



OUTLINE OF PC BOARD, P/N 265-1003
 COMPONENT ASSY NO. 311-1103

OUTLINE OF CAN,
 P/N 295-1036

- R703 WAS 560Ω PRIOR TO S/N 1501.
- 10.7 MHz SIGNAL PATH (PRIMARY)
- AUDIO AND/OR COMPOSITE SIGNAL PATH (PRIMARY)

UNLESS OTHERWISE NOTED:
 ALL RESISTORS ARE IN OHMS 1/4W 5%
 ALL CAPACITORS IN DECIMALS AND LESS
 THAN 1 ARE μF,
 ALL OTHER CAPACITORS ARE pF
 *ALL INDUCTORS ARE IN μH

ALL VOLTAGES SHOWN ARE ±10% (UNLESS
 OTHERWISE NOTED) TAKEN WITH A DC VTVM
 HAVING AN INPUT IMPEDANCE OF 200 MEG-
 OHMS AND AN AC VTVM HAVING AN INPUT
 IMPEDANCE OF 1 MEGOHM. LINE VOLTAGE
 EQUALS 120 VAC AT 60 Hz.

FIGURE 12A - DETECTOR SCHEMATIC DIAGRAM

THE PARTS LIST FOR THIS UNIT IS LOCATED ON
 PAGE 79.

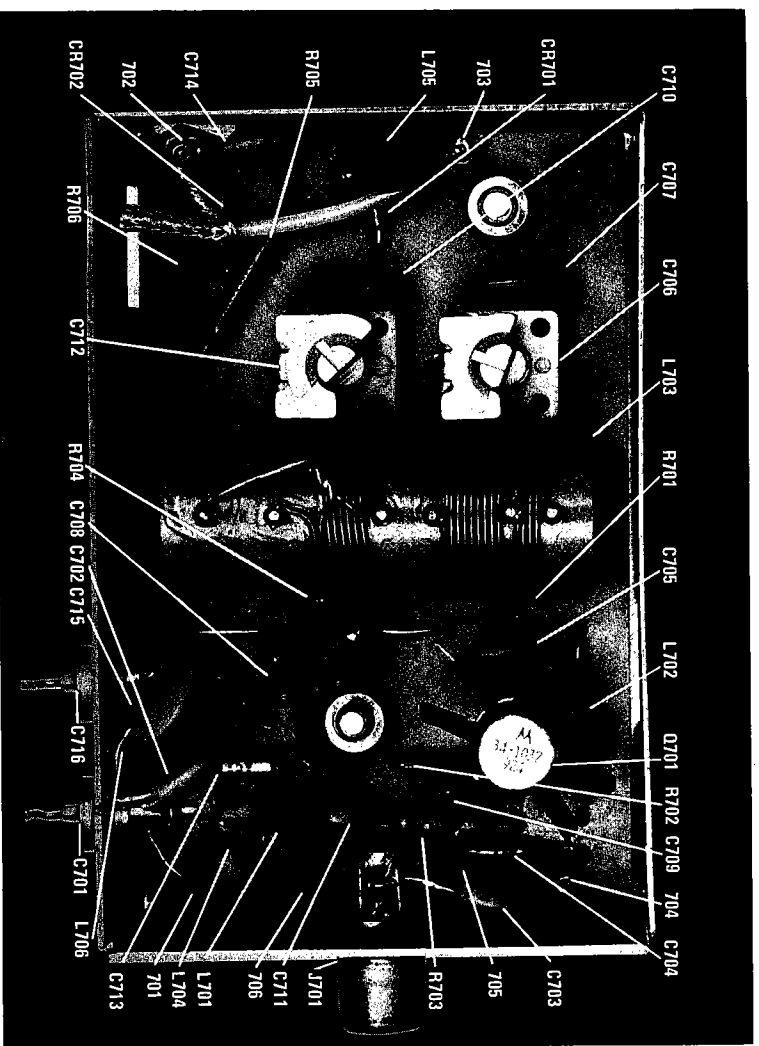

FIGURE 12B - DETECTOR COMPONENT DIAGRAM

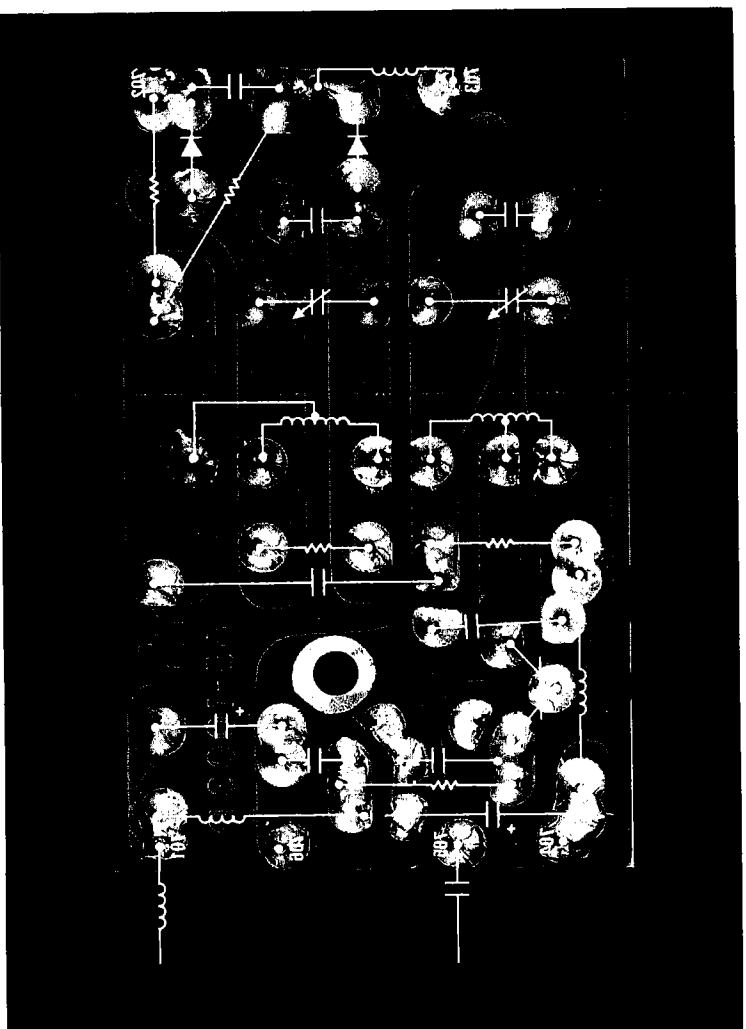

FIGURE 12D - DETECTOR CONDUCTOR PATTERN DIAGRAM (AS VIEWED FROM THE COMPONENT SIDE OF BOARD)

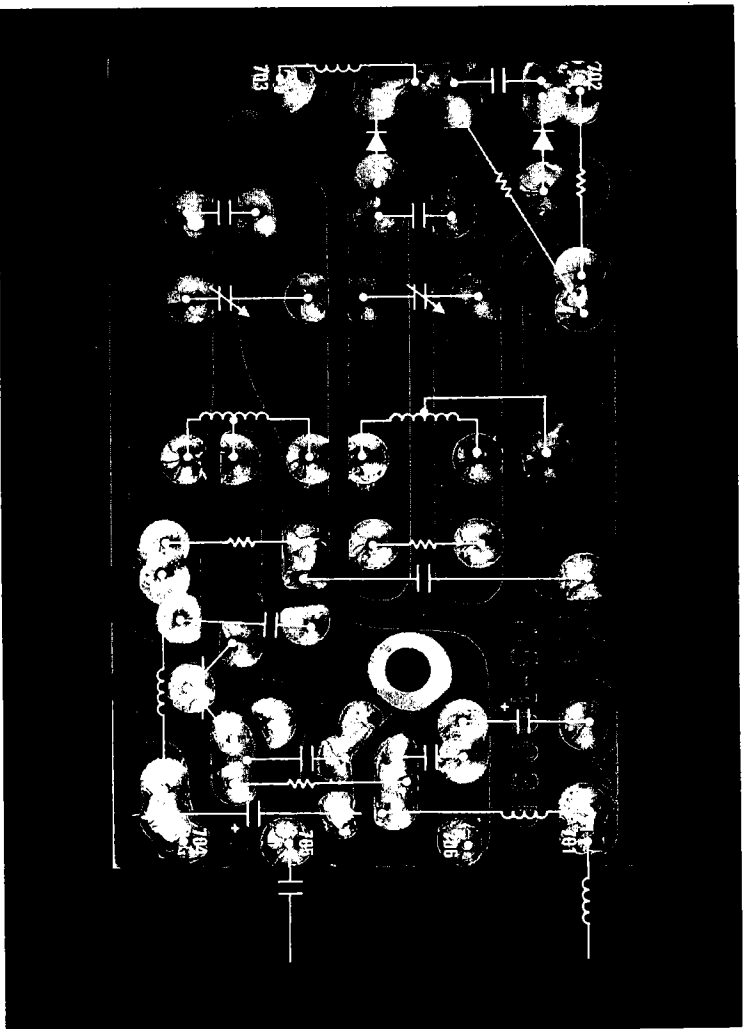
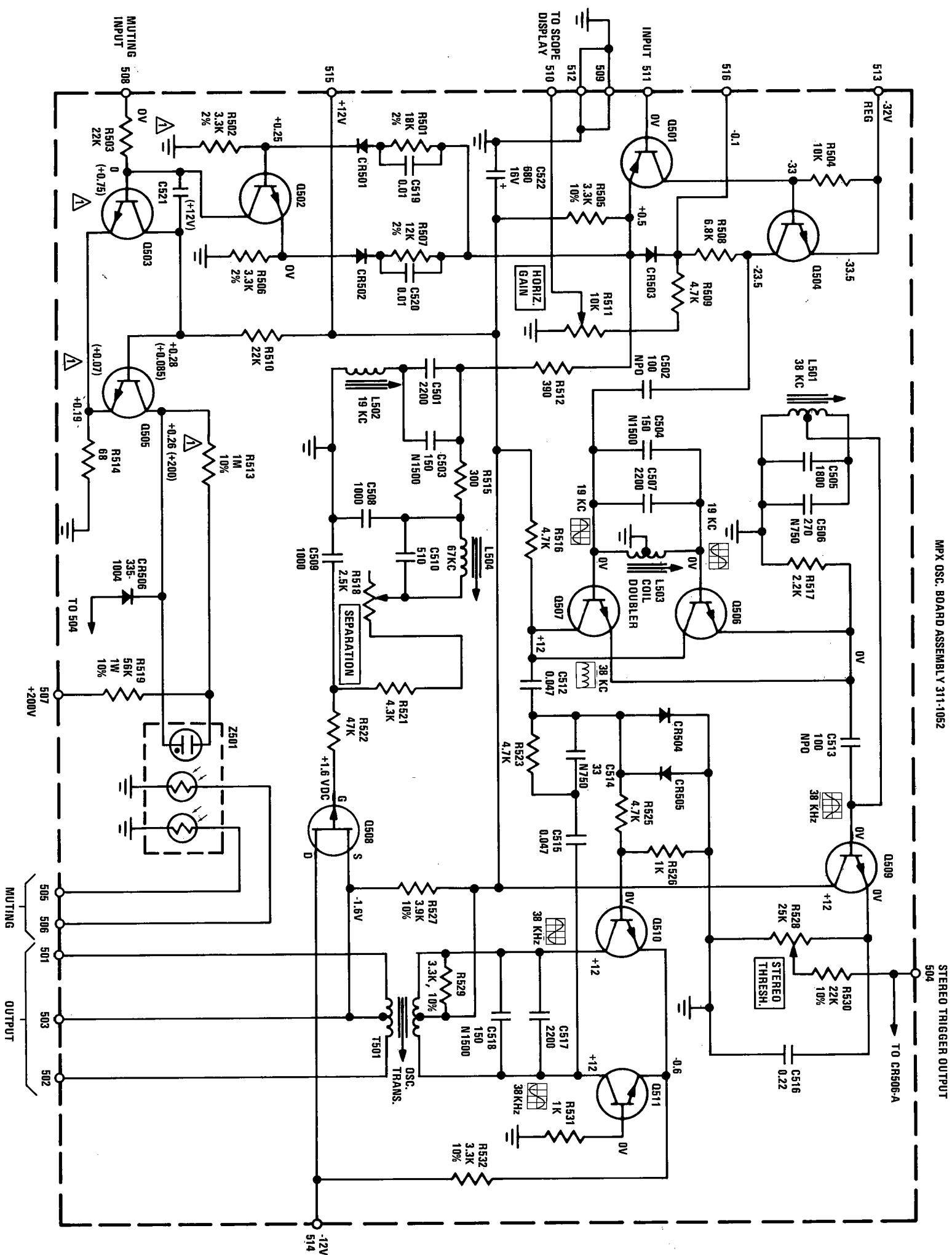

FIGURE 12C - DETECTOR CONDUCTOR DIAGRAM

DETECTOR (DISCRIMINATOR) ALIGNMENT

1. Unsolder and disconnect P201 (front end output cable) from J301 (IF input jack).
2. Connect 10.7 MHz crystal oscillator to J301.
3. Connect a V.T.V.M. (D.C.), set to 0.5 volt scale and adjusted to zero (0) at center scale, to the center pin of the "4 CHANNEL ADAPTOR" jack and the chassis.
4. Turn on crystal oscillator and adjust the "secondary" (C712) for zero volts on the V.T.V.M. (Note: You may have to "over adjust" in one direction or the other to compensate for alignment tool capacity).
5. Disconnect crystal oscillator and reconnect P201 and SOLDER.
6. Connect F.M. generator to "ANTENNA" terminals.
7. Connect distortion analyzer to either channel "TAPE OUT" jack.
8. Set F.M. generator to monaural and adjust for 100% modulation at 400 Hz 1 K μ V output.
9. Set Model 19 controls as follows:
Selector - "F.M.",
Volume Control - Minimum (full C.C.W.)
All push buttons (except "muting off") out.
10. Tune Model 19 to generator frequency and "fine tune" it to indicate "0" volts on D.C. V.T.V.M.
11. Set distortion analyzer up to read distortion and null.
12. Adjust "primary" (C706) for minimum distortion.
13. Check distortion on other "tape out" jack and retouch "primary" to give the best compromise for lowest distortion on both channels. It must be less than 0.15%. If not, see "TROUBLE ANALYSIS" section of this manual.



Δ VOLTAGES IN PARENTHESES TAKEN WITH "MUTING OFF" PUSHBUTTON IN.

- 2 ALL VOLTAGES SHOWN TAKEN WITH PIN 511 CONNECTED TO PIN 512 (GROUND).
- 3 WAVEFORMS SHOWN ARE WITH 19 KHz PILOT ONLY - NO MODULATION. - AND ARE FOR APPROXIMATE PHASE RELATIONSHIP ONLY.

ALL VOLTAGES SHOWN ARE ±10% (UNLESS OTHERWISE NOTED) TAKEN WITH A DC VTVM HAVING AN INPUT IMPEDANCE OF 200 MEG-OHMS AND AN AC VTVM HAVING AN INPUT IMPEDANCE OF 1 MEGOHM. LINE VOLTAGE EQUALS 120 VAC AT 60 Hz.

UNLESS OTHERWISE NOTED:
 ALL RESISTORS ARE IN OHMS $\frac{1}{2}$ W 5%
 ALL CAPACITORS IN DECIMALS AND LESS THAN 1 ARE μ F.
 ALL OTHER CAPACITORS ARE PF
 ALL INDUCTORS ARE IN μ H

THE PARTS LIST FOR THIS UNIT IS LOCATED ON PAGE 75.

FIGURE 13A - MPX OSCILLATOR SCHEMATIC DIAGRAM

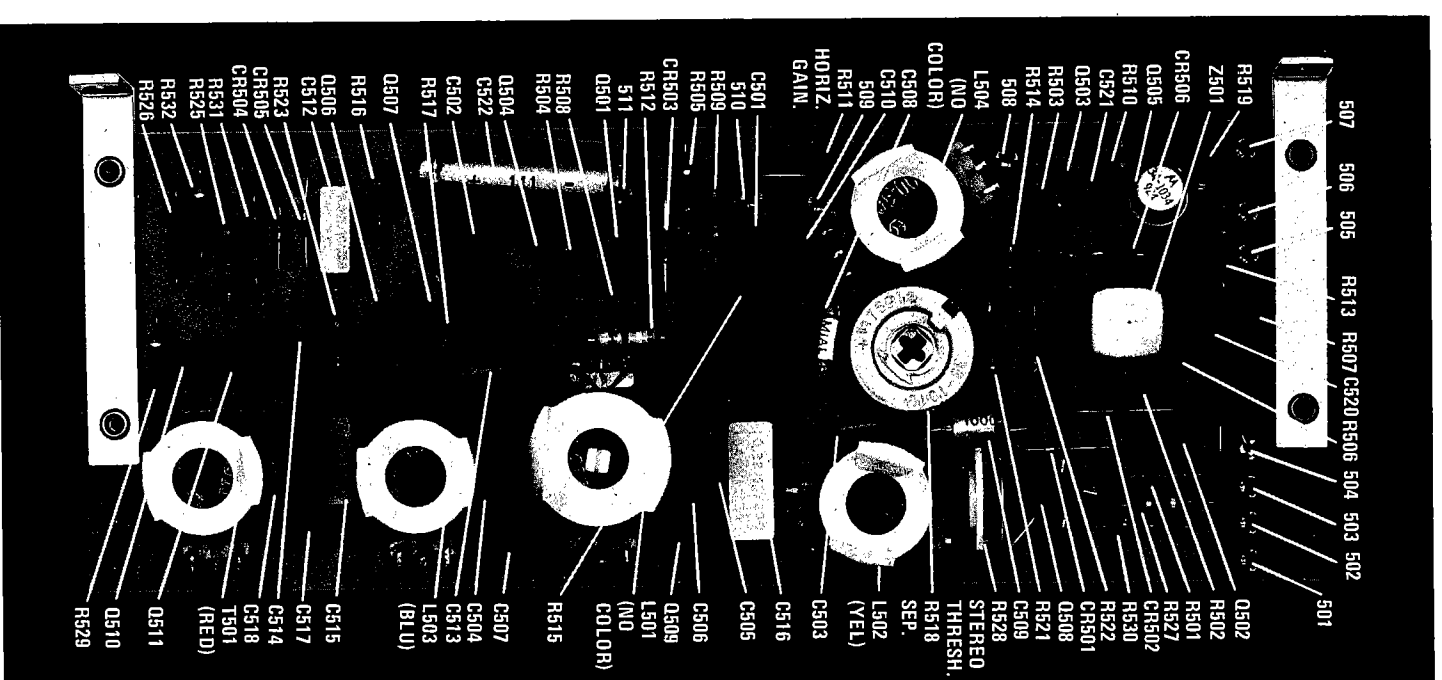
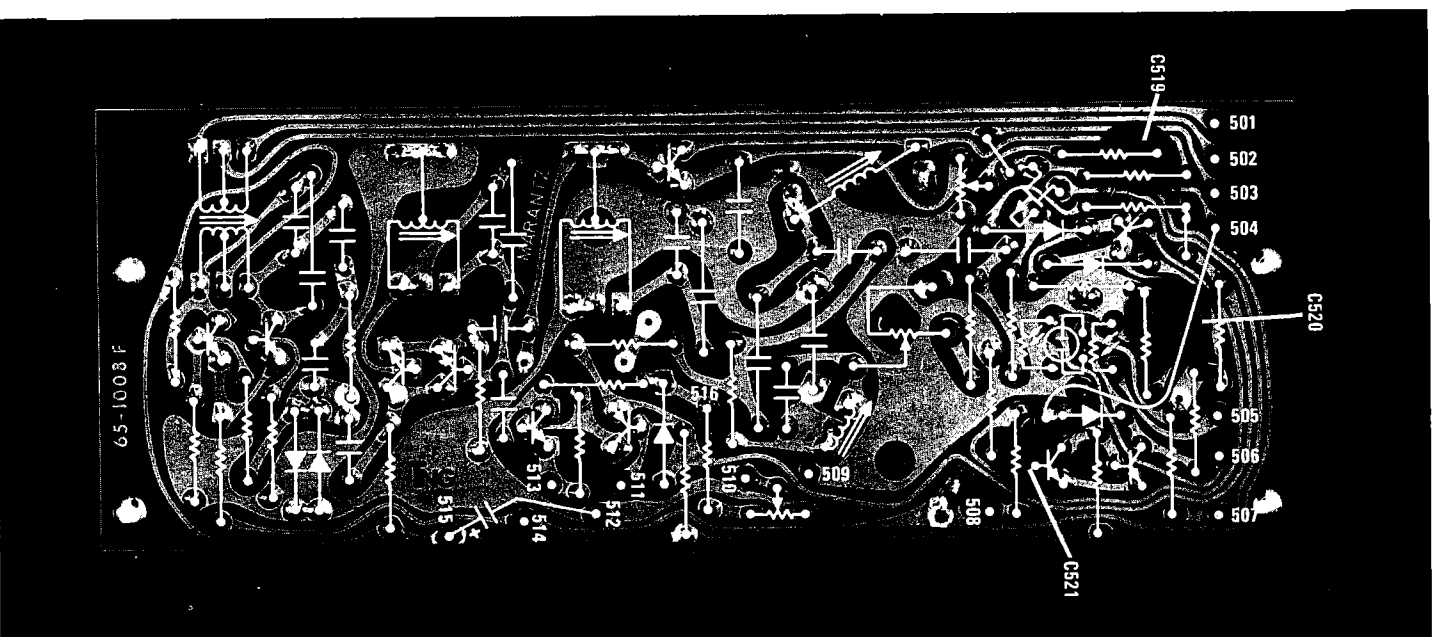

FIGURE 13B - MPX OSCILLATOR CONDUCTOR DIAGRAM

FIGURE 13C - MPX OSCILLATOR COMPONENT DIAGRAM

39

MULTIPLEX ALIGNMENT PROCEDURE

Note: Before doing multiplex alignment, check or do the alignment of the detector (discriminator).

1. Connect F.M. stereo generator to "ANTENNA" terminals.
2. Turn on Model 19 and allow it to "warm up" for 10 to 15 minutes.
3. Set Model 19 controls as follows: selector - "F.M.", "VOLUME" - minimum (full-C.C.W.); balance and tone controls - center; speaker switch - "OFF"; press the following push buttons: SCOPE ON and MUTING OFF.
4. Connect the scope vertical input to output of distortion analyzer.
5. Set distortion analyzer to "SET LEVEL" and increase the "SENSITIVITY" to maximum.
6. Connect a short jumper between the emitter and base of Q510.
7. Connect a standard Tektronics X1 probe to distortion analyzer input and connect as per chart and to ground.
8. Set F.M. stereo generator to 1 K μ V output and 98 MHz. Tune Model 19 to generator.
9. Align as indicated in the following chart.
10. Seal all above adjustments EXCEPT L503 and DO NOT disturb during remaining alignment. Remove jumper from Q510 emitter-base.
11. Set F.M. generator to STEREO; pilot level - 10%; and modulate with 15 KHz (90%) either left (A) or right (B) and monitor opposite "TAPE OUTPUT" jack with distortion analyzer.
12. Adjust T501 and tuning of Model 19 for maximum separation. Note: If a "null" for maximum separation cannot be reached, retouch L503 slightly and adjust T501 again.
13. Adjust R518 and R606 for maximum and equal separation (at 15 KHz) for both R to L and L to R. Retouch T501 if necessary and "retune" Model 19 as required.

(cont. on page 44)

STEP	F.M. GENERAL FUNCTION	F.M. GENERAL FUNCTION	% OF MODULATION	CONNECT ANALYZER TO	ADJUST	NOTES
A	STEREO	19 KHz PILOT ONLY	10	PIN NO. 503	L502	ADJUST FOR MINIMUM OUTPUT
B	STEREO	19 KHz PILOT ONLY	10	COLLECTOR OF Q506 OR Q507	L503	ADJUST FOR MAXIMUM OUTPUT
C	SCA	1 KHz (INTERNAL)	20	PIN NO. 503	L504	ADJUST FOR MINIMUM OUTPUT
D	STEREO	19 KHz PILOT ONLY	10		L501	ADJUST FOR MAXIMUM OUTPUT
E	STEREO	19 KHz PILOT ONLY	6		R528	ADJUST C.W. UNTIL STEREO LIGHT COMES ON

*WRAP 1 TURN OF INSULATED WIRE AROUND L501 AND CONNECT ANALYZER BETWEEN IT AND GROUND. NOTE: MAKE SURE PROBE IS NOT LYING NEXT TO COILS, OTHERWISE A FALSE READING WILL BE OBTAINED.

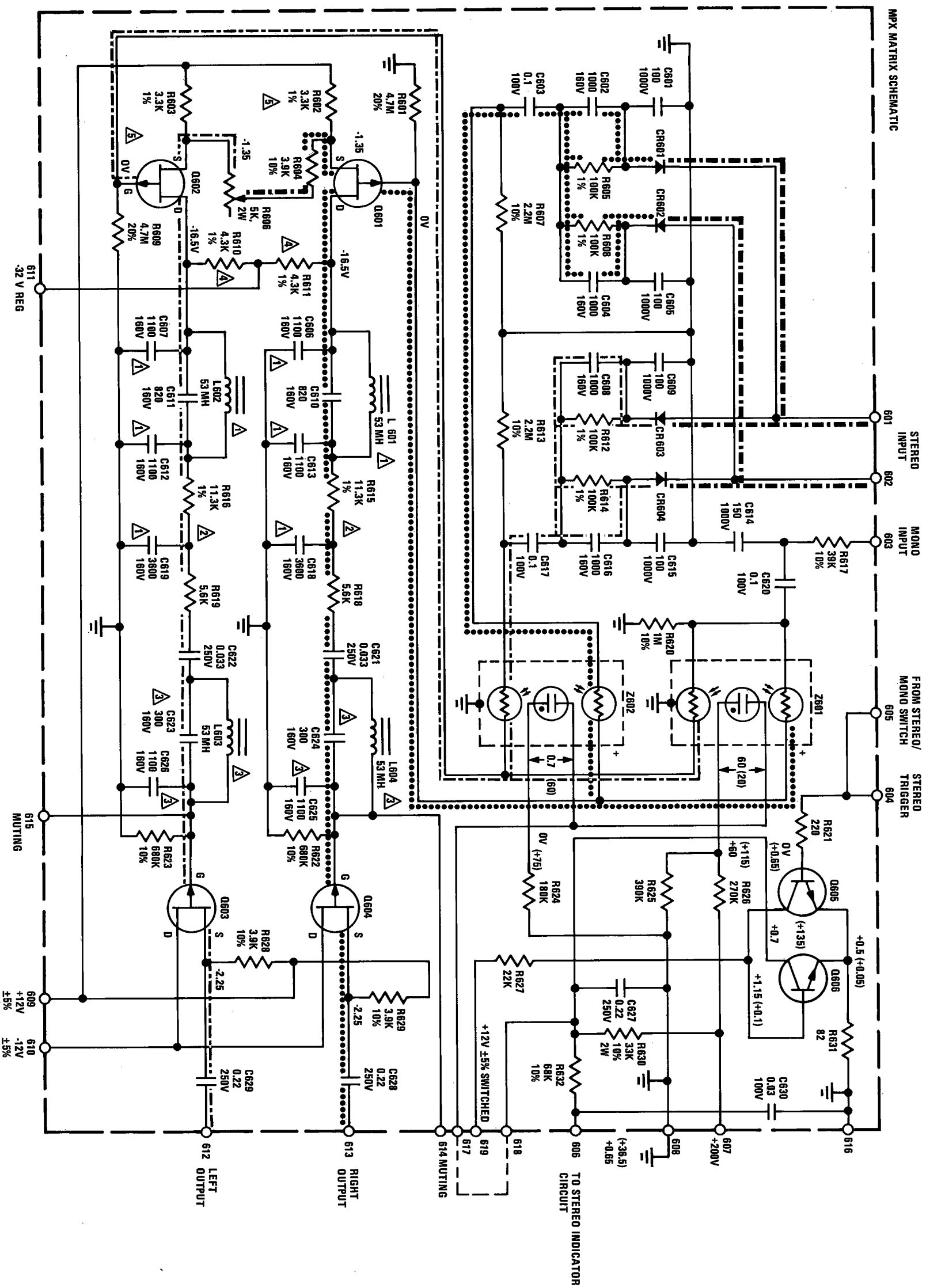

ALL VOLTAGES SHOWN ARE ±10% (UNLESS OTHERWISE NOTED) TAKEN WITH A DC VTVM HAVING AN INPUT IMPEDANCE OF 200 MEG-OHMS AND AN AC VTVM HAVING AN INPUT IMPEDANCE OF 1 MEGOHM: LINE VOLTAGE EQUALS 120 VAC AT 60 Hz.

UNLESS OTHERWISE NOTED:
 ALL RESISTORS ARE IN OHMS ¼W 5%
 ALL CAPACITORS IN DECIMALS AND LESS THAN 1 ARE µF
 ALL OTHER CAPACITORS ARE pF
 *ALL INDUCTORS ARE IN µH

- △ L601, L602, C606, C607, C610, C611, C612 AND C613 COMPRISE 19 KHz TO 24 KHz FILTER.
- △ R615 AND R616 WITH C618 AND C619 PROVIDE THE MAJOR PORTION OF 75 µS DEMPHERS. TO CHANGE TO 50 µS (EUROPEAN), CHANGE R615 AND R616 TO 5.3K OR PARALLEL EXISTING 11.3K ±% RESISTORS WITH 1 EACH 10K ±1% RESISTOR.
- △ L604, L603, C623, C624, C625 AND C626 COMPRISE 38 KHz FILTER.

- △ R610 AND R611 WERE 5.1K PRIOR TO S/N 1101.
- △ R602 AND R603 WERE 3.6K PRIOR TO S/N 1101.
- RIGHT CHANNEL AUDIO
- LEFT CHANNEL AUDIO
- COMPOSITE WAVEFORM (PRIMARY SIGNAL)

VOLTAGES IN PARENTHESES IN STEREO MODE. ALL OTHER VOLTAGES TAKEN WITH PIN 511 ON OSCILLATOR BOARD GROUNDED TO PIN 512.

FIGURE 14A - MPX MATRIX SCHEMATIC DIAGRAM

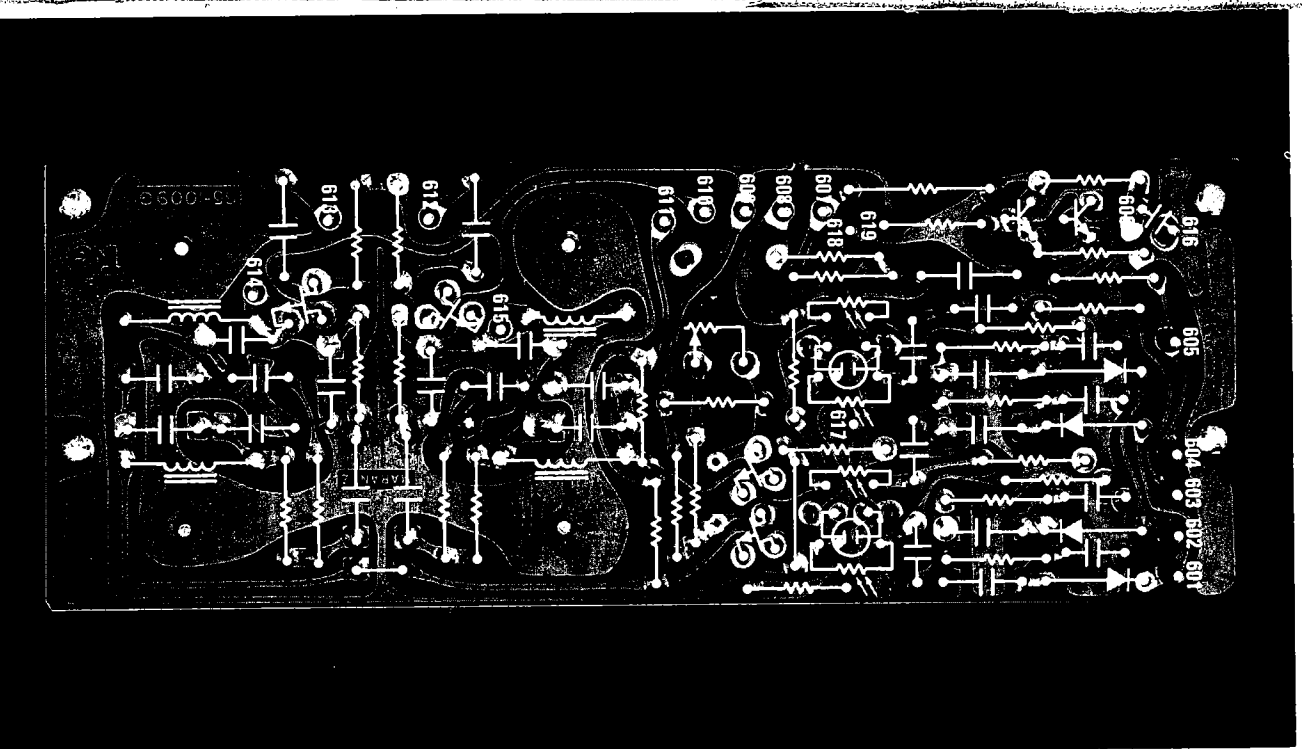

FIGURE 14B - MPX MATRIX CONDUCTOR DIAGRAM

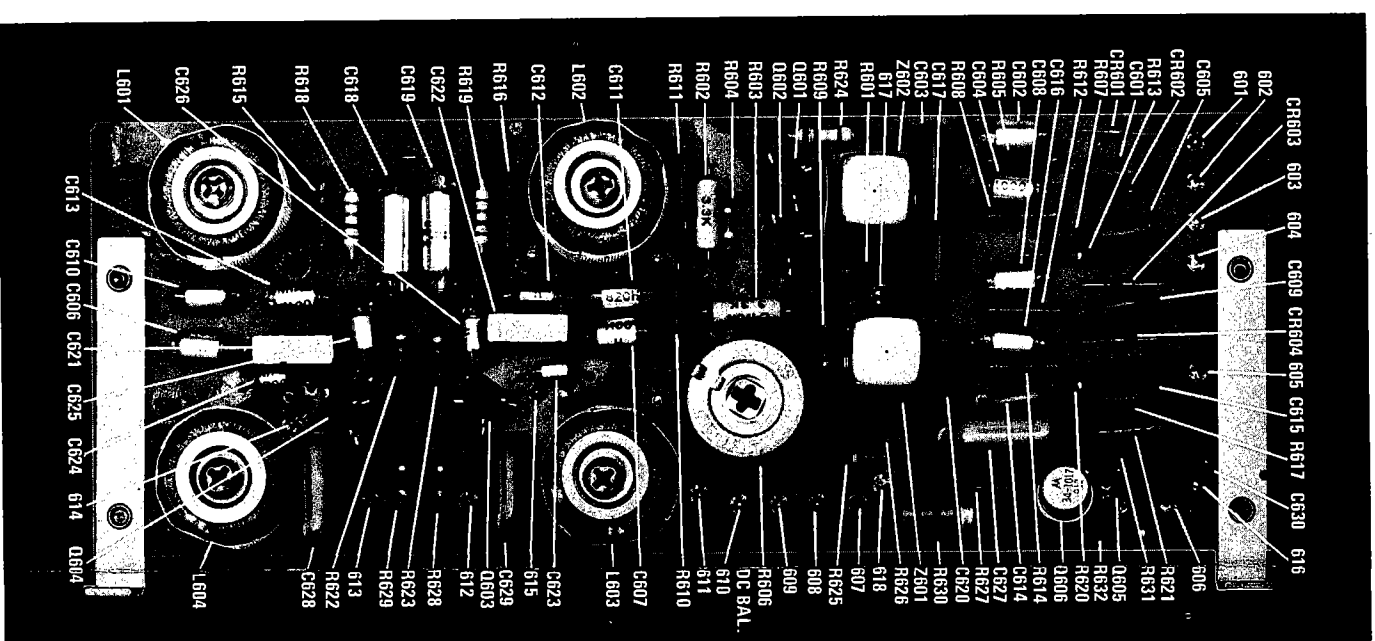
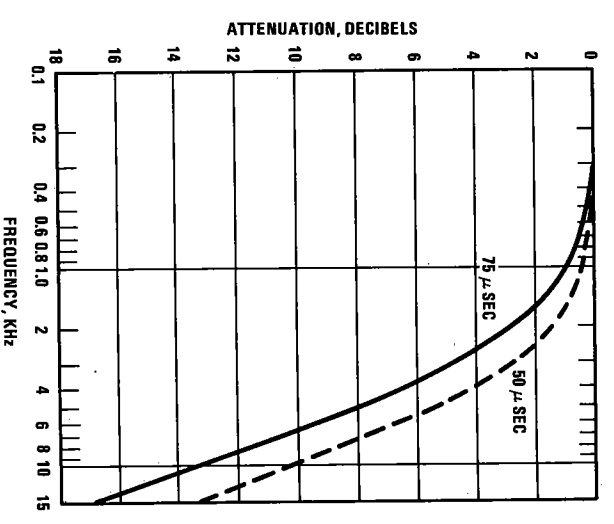
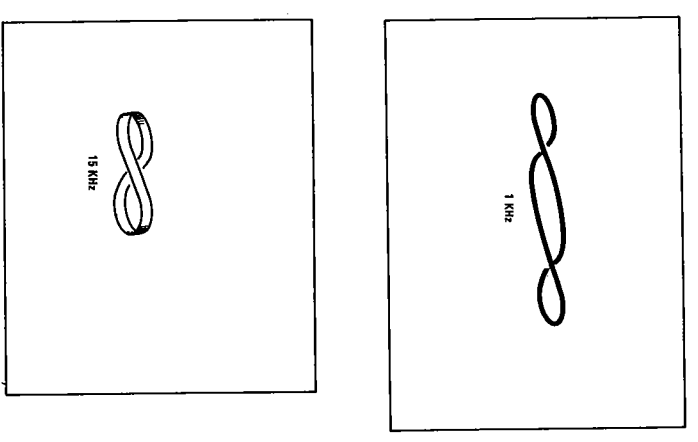

FIGURE 14C - MPX MATRIX COMPONENT DIAGRAM



f (Hz)	ATTENUATION (DB) 75 μs	ATTENUATION (DB) 50 μs
20-200	0	0
400	.15	0
1K	.86	.41
2K	2.73	1.43
3K	4.74	2.74
4K	6.48	4.05
5K	8.13	5.38
10K	13.59	10.31
15K	17.02	13.59

FIGURE 14D - ATTENUATION CURVE



14. Change modulation to 1 KHz and readjust R518 and R606 for maximum and equal separation.
15. Recheck separation at 15 KHz for a minimum of 30 dB separation. Retouch T501 if necessary, then recheck separation at 1 KHz. for 45 dB minimum separation.
16. With audio generator connected to horizontal input of scope and distortion analyzer output connected to scope vertical input; patterns should appear approximately as shown when properly aligned.
17. Set F.M. generator to monaural, modulation - 1 KHz, 100%.
18. Press "MULTIPATH" scope pushbutton.
19. Adjust output of F.M. generator until the horizontal line is centered vertically on the scope.
20. Adjust R511 (HORIZ. GAIN) until the horizontal line just touches the two vertical lines at each side of the scope reticule. If necessary, readjust then "tuning" of the Model 19 to center the line horizontally.

FIGURE 15A - PHONO AMP SCHEMATIC DIAGRAM

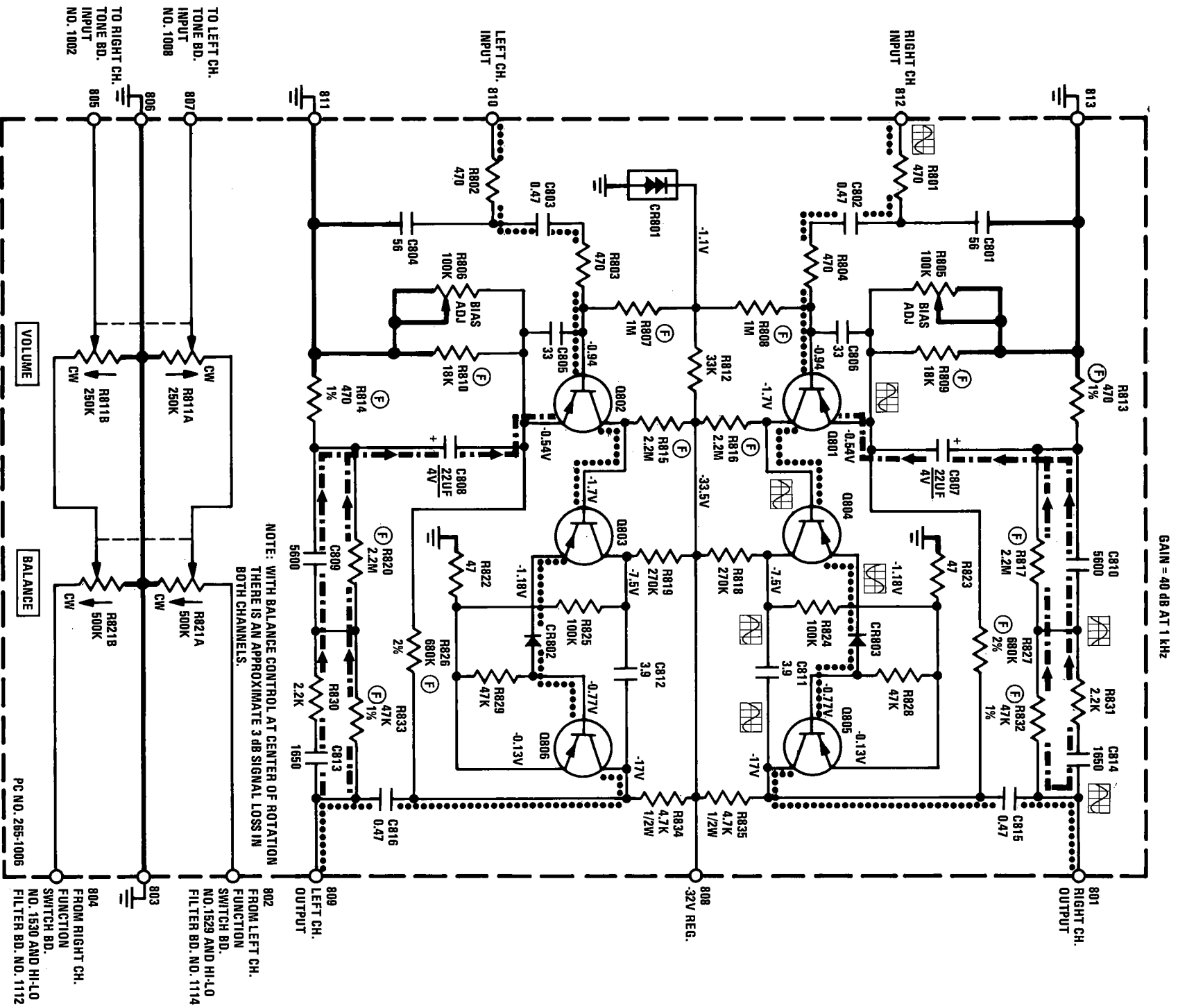
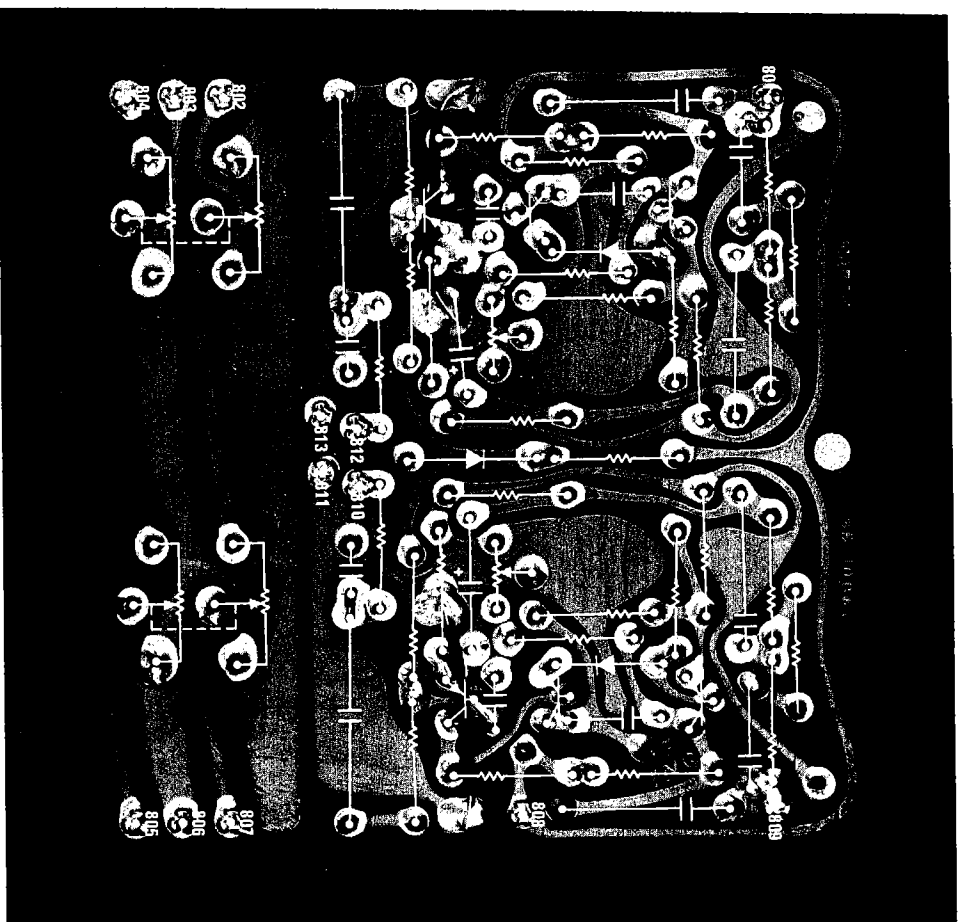

FIGURE 15B - PHONO AMP CONDUCTOR DIAGRAM



ALL VOLTAGES SHOWN ARE $\pm 10\%$ (UNLESS OTHERWISE NOTED) TAKEN WITH A DC VTVM HAVING AN INPUT IMPEDANCE OF 200 MEG-OHMS AND AN AC VTVM HAVING AN INPUT IMPEDANCE OF 1 MEGOHM. LINE VOLTAGE EQUALS 120 VAC AT 60 HZ.

UNLESS OTHERWISE NOTED:
 ALL RESISTORS ARE IN OHMS $\frac{1}{2}W$ 5%
 ALL CAPACITORS IN DECIMALS AND LESS THAN 1 ARE μF
 ALL OTHER CAPACITORS ARE pF
 *ALL INDUCTORS ARE IN μH
 (F) DENOTES PRECISION FILM RESISTORS

AC WAVEFORMS ARE SHOWN FOR APPROXIMATE PHASE RELATIONSHIP ONLY.

●●●●● SIGNAL PATH
 ■■■■■ FEEDBACK PATH

THE PARTS LIST FOR THIS UNIT IS LOCATED ON PAGE 80.

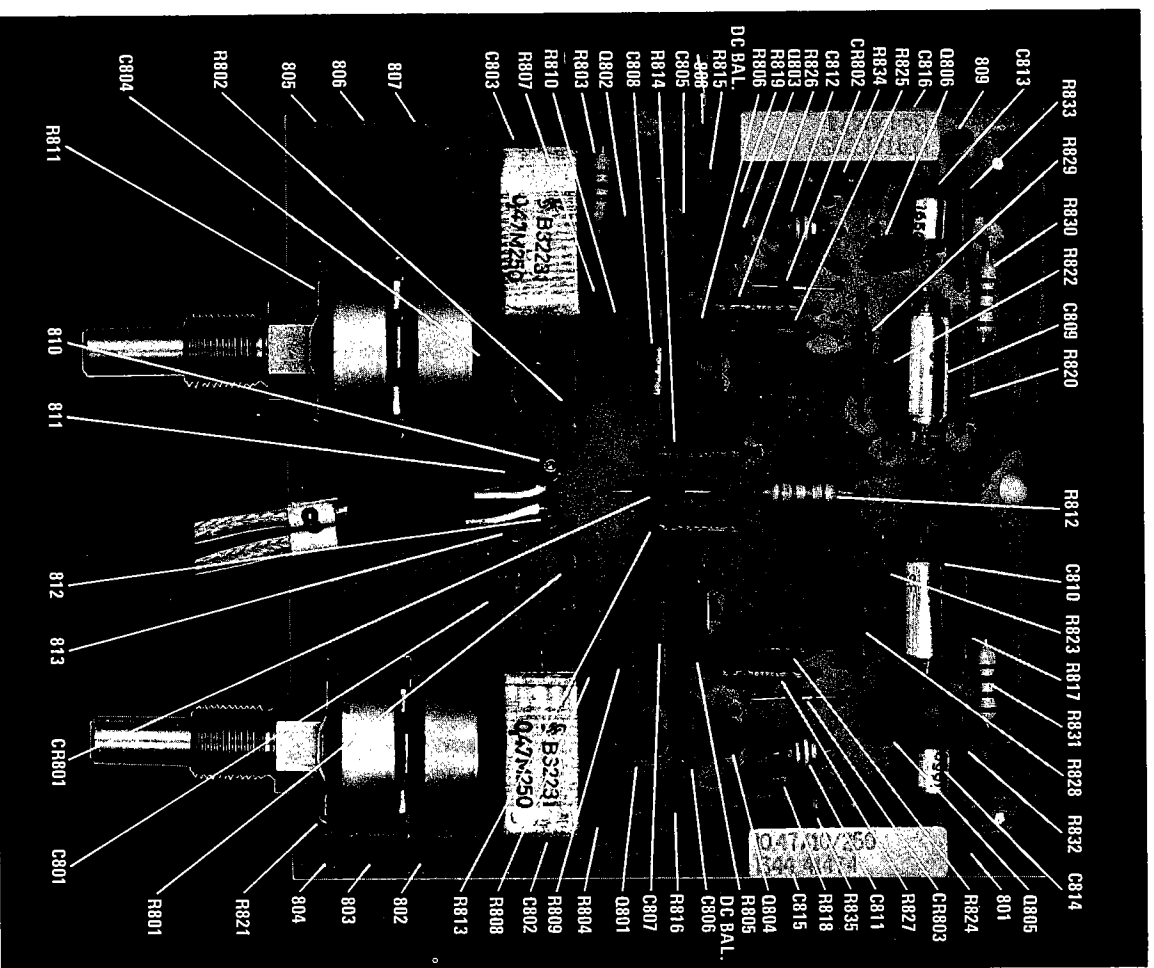

FIGURE 15C - PHONO AMP COMPONENT DIAGRAM

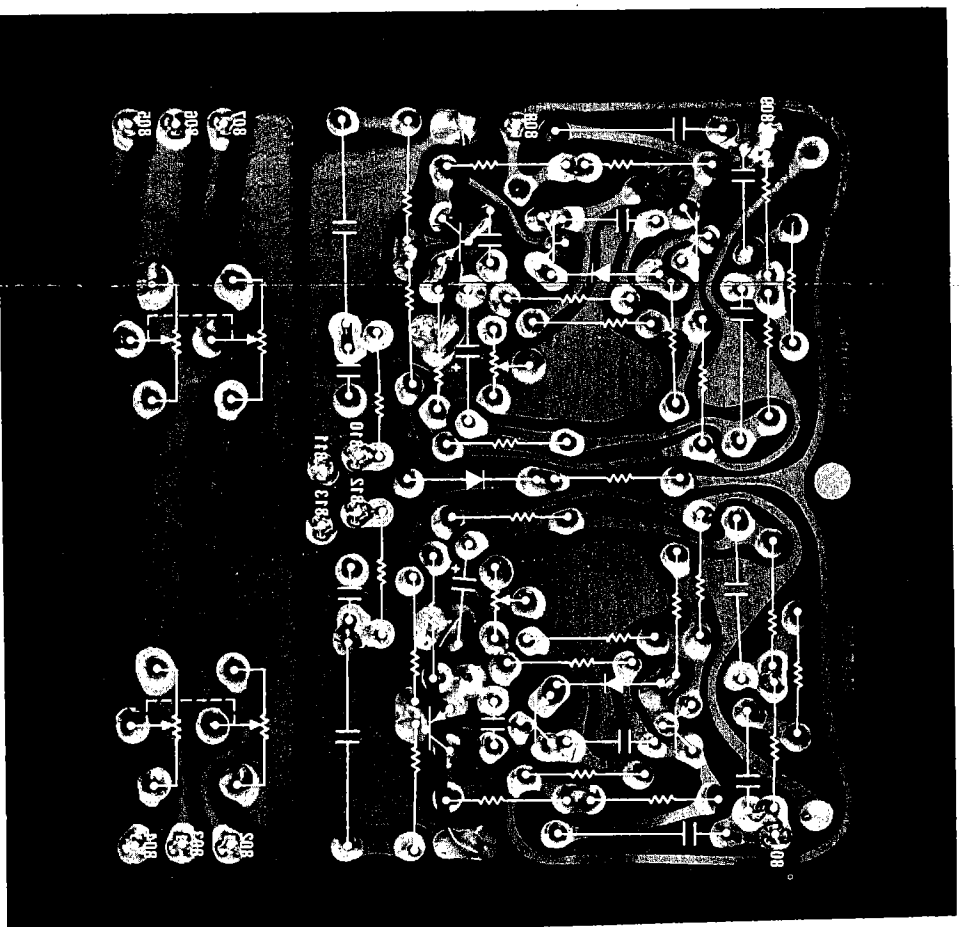
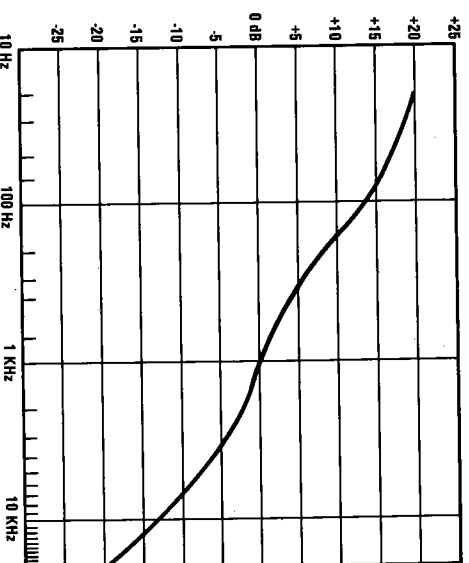

FIGURE 15D - PHONO AMP CONDUCTOR PATTERN DIAGRAM (AS VIEWED FROM THE COMPONENT SIDE OF BOARD)

PHONO BOARD ADJUSTMENTS

1. Connect Audio Generator to "Phono 1", channel "A" input. Frequency-1 KHz sine wave.
2. Connect A.C. V.T.V.M (or distortion analyzer) and oscilloscope vertical input to channel "A" "tape output". (Note: Turn volume control to minimum; maximum C.C.W.).
3. Adjust Audio Generator output for approximately 10 volts R.M.S. at the "tape output" jack. Adjust scope sensitivity and sweep speed so that sine wave covers almost entire screen.
4. Increase Generator output until clipping just starts to occur as seen on scope.
5. Adjust R806 ("Pot" on left side of Phono board; unit upside down; front panel towards you) until clipping occurs at the top and bottom of the sine wave at the same time. Note: It may be necessary to readjust Generator output up or down slightly in order to see just when clipping occurs as the adjustment is made.
6. Move input and output connections to channel "B" and adjust R805 ("Pot" on right side of board) as outlined above.
7. This completes adjustment of the Phono board. The RIAA equalization curve of the board may be checked against the curve and chart below.



RIAA NAB DISK REPRODUCING STD.

20 KHz	-20 dB
15 KHz	-17.17 dB
14 KHz	-16.64 dB
13 KHz	-15.95 dB
12 KHz	-15.28 dB
11 KHz	-14.55 dB
10 KHz	-13.75 dB
9 KHz	-12.88 dB
8 KHz	-11.91 dB
7 KHz	-10.85 dB
6 KHz	-9.62 dB
5 KHz	-8.23 dB
4 KHz	-6.59 dB
3 KHz	-4.70 dB
2 KHz	-2.81 dB
1000	-1.23 dB
400	+0.82 dB
300	+3.81 dB
200	+8.22 dB
100	+13.11 dB
70	+15.31 dB
50	+16.96 dB
30	+18.61 dB
20 Hz	+20 dB

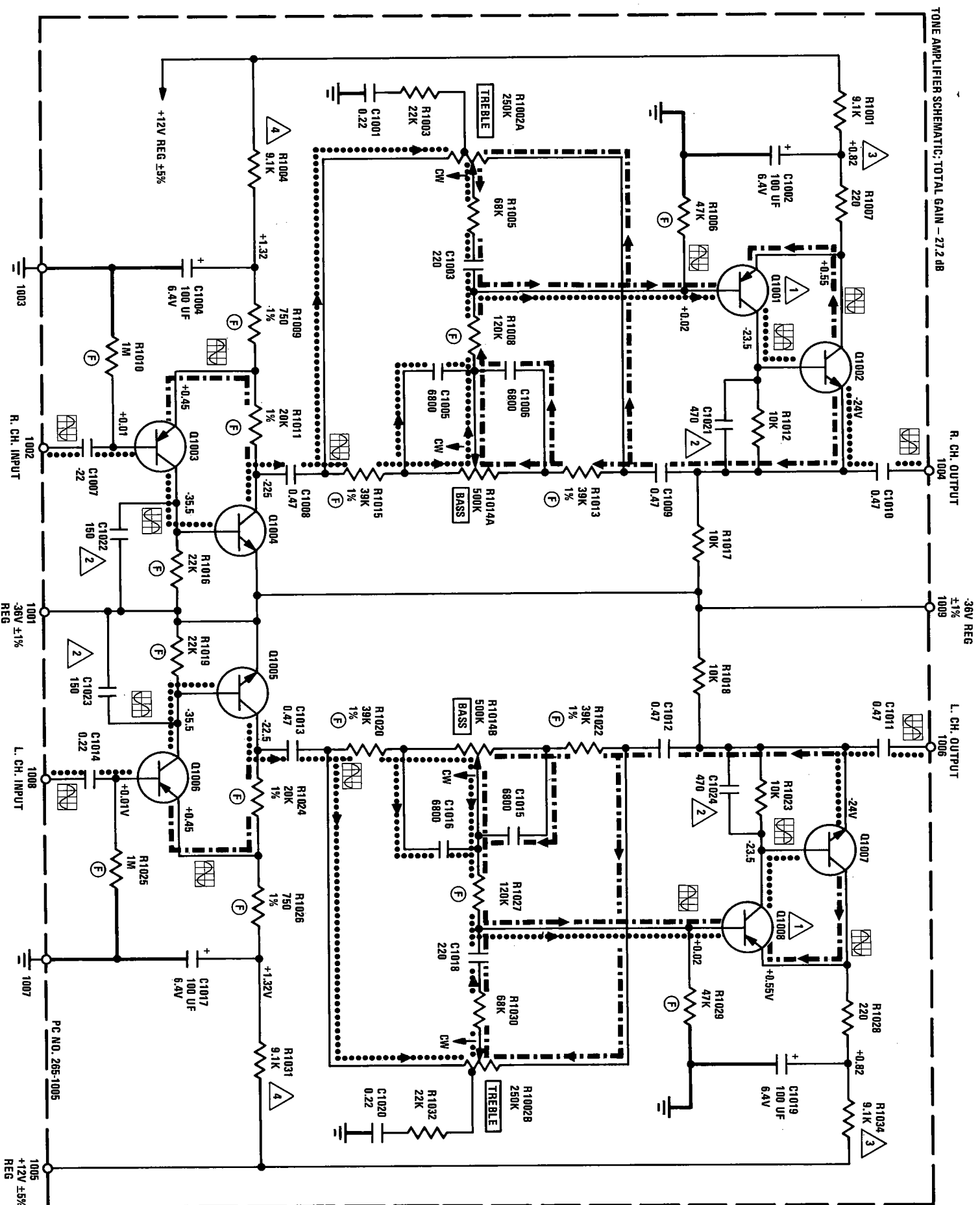

FIGURE 16A - TONE SCHEMATIC DIAGRAM

ALL VOLTAGES SHOWN ARE $\pm 10\%$ (UNLESS OTHERWISE NOTED) TAKEN WITH A DC VTVM HAVING AN INPUT IMPEDANCE OF 200 MEG-OHMS AND AN AC VTVM HAVING AN INPUT IMPEDANCE OF 1 MEGOHM: LINE VOLTAGE EQUALS 120 VAC AT 60 HZ.

UNLESS OTHERWISE NOTED: ALL RESISTORS ARE IN OHMS $\frac{1}{W}$ 5% ALL CAPACITORS IN DECIMALS AND LESS THAN 1 ARE μF . ALL OTHER CAPACITORS ARE pF *ALL INDUCTORS ARE IN μH

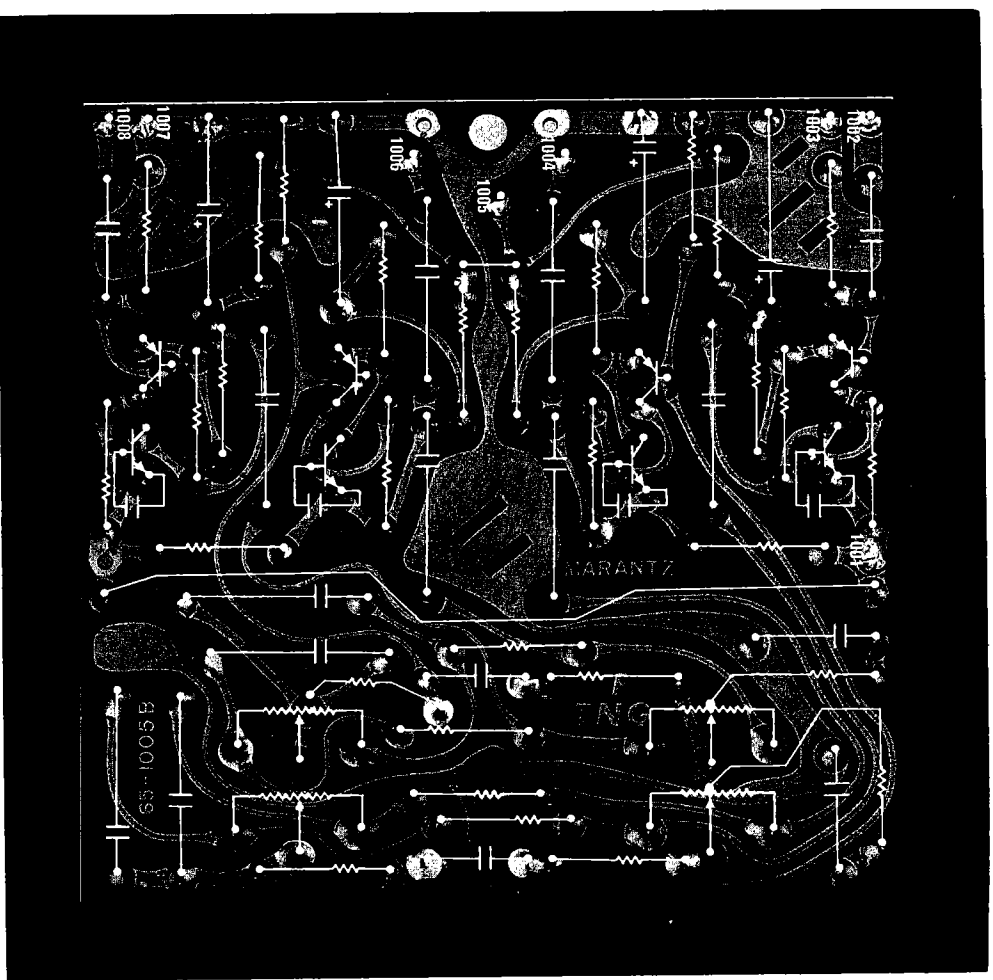

FIGURE 16B - TONE CONDUCTOR DIAGRAM

- △ Q1001 AND Q1008 WERE P/N 334-1008 PRIOR TO S/N 1501.
- △ C1021, C1022, C1023 AND C1024 ADDED AT S/N 1501.
- △ R1001 AND R1034 WERE 15K PRIOR TO S/N 1501.
- △ R1004 AND R1031 WERE 10K PRIOR TO S/N 1501.
- SIGNAL PATH (PRIMARY)
- ■ ■ ■ ■ FEEDBACK PATH
- Ⓟ DENOTES PRECISION FILM RESISTORS.
- 6 WAVEFORMS ARE FOR APPROXIMATE PHASE RELATIONSHIP ONLY WITH TONE CONTROLS SET FLAT.

THE PARTS LIST FOR THIS UNIT IS LOCATED ON PAGE 82.

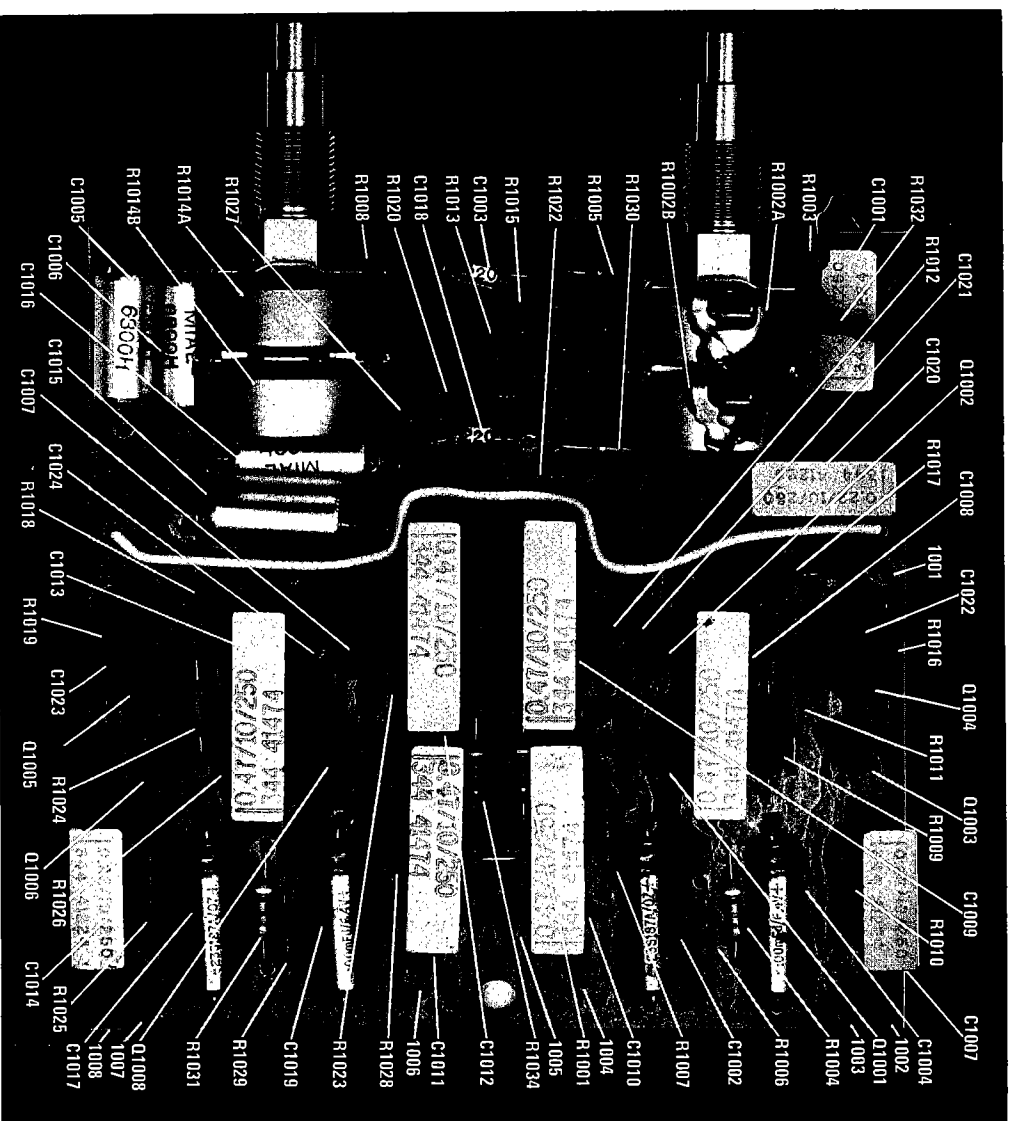

FIGURE 16C - TONE COMPONENT DIAGRAM

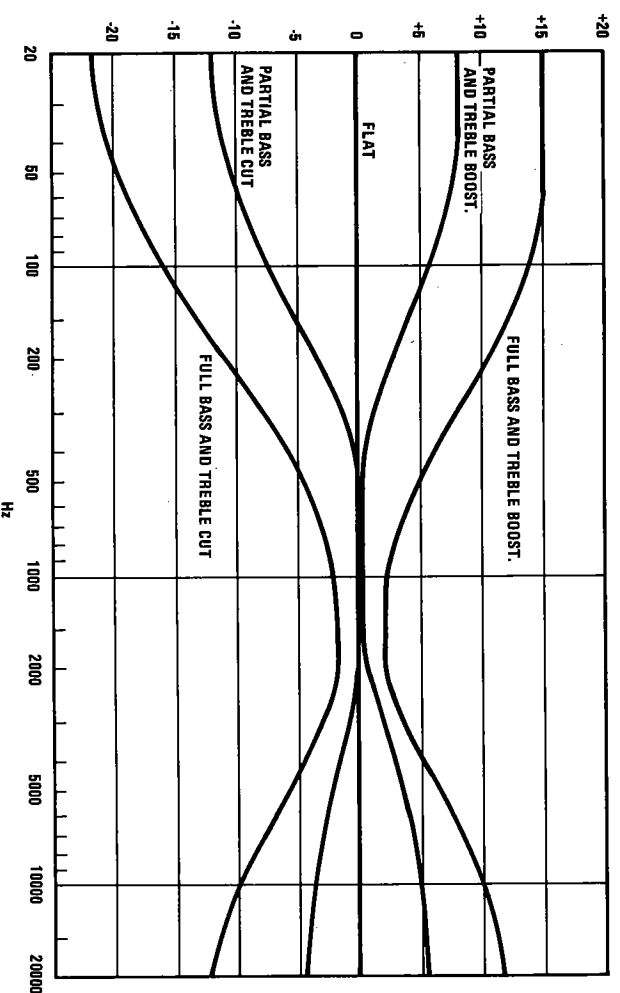

FIGURE 16E - TONE CONTROL CURVES

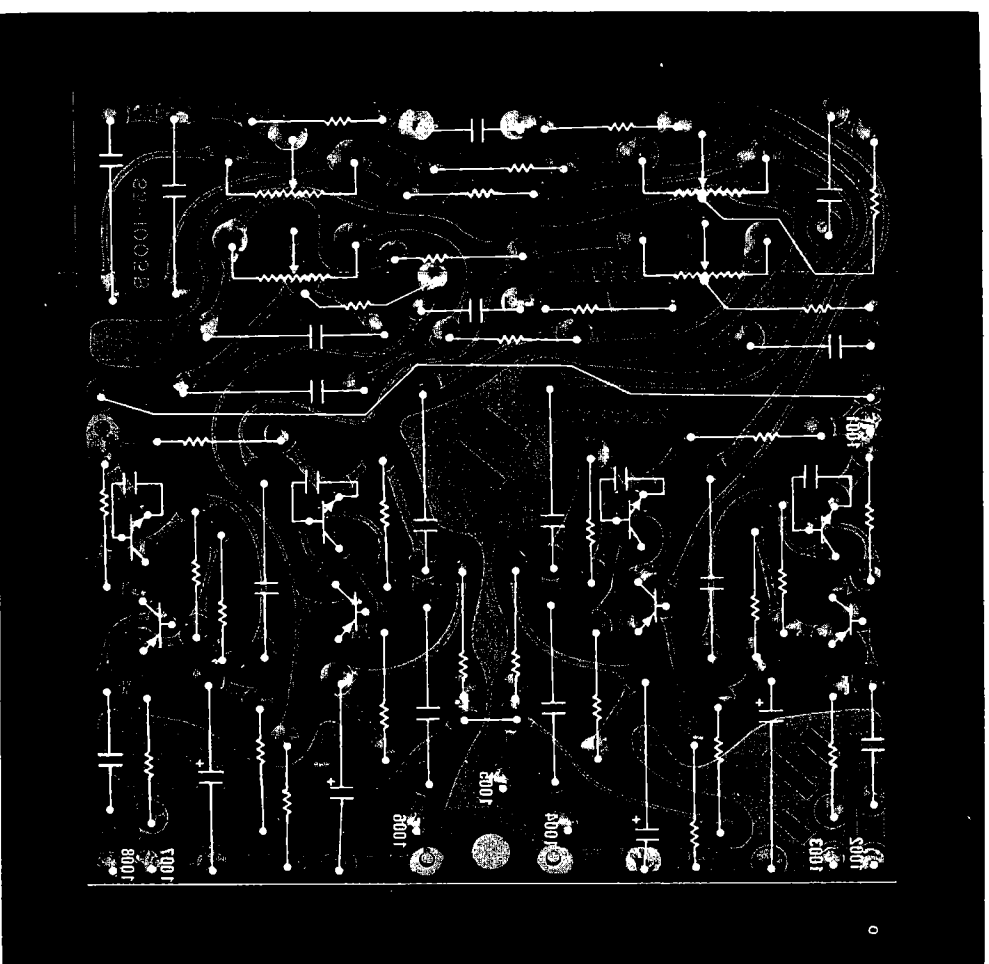
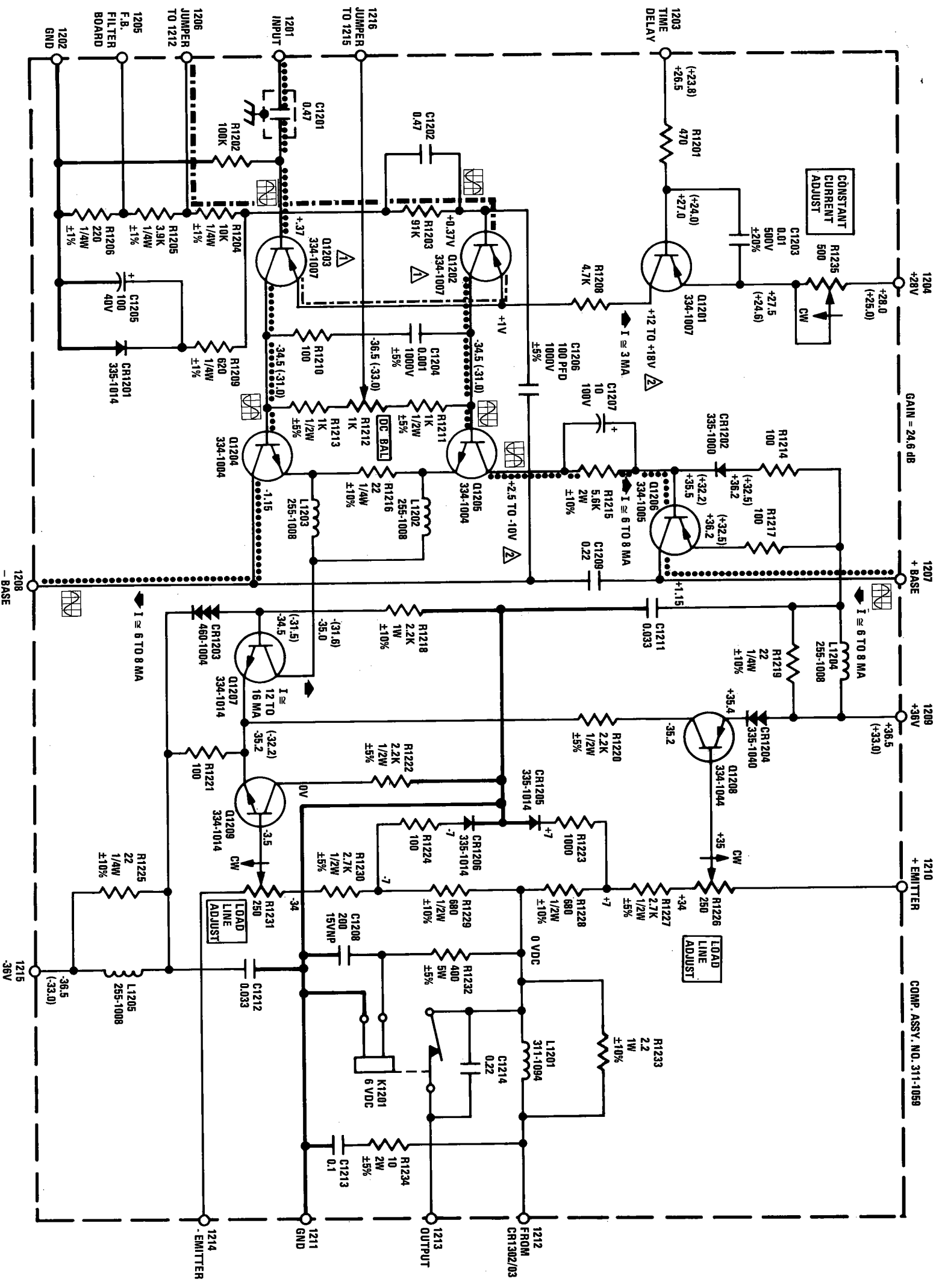

FIGURE 16D - TONE CONDUCTOR PATTERN DIAGRAM (AS VIEWED FROM THE COMPONENT SIDE OF BOARD)

TONE CONTROL AND BALANCE KNOB

In the event that the "BALANCE" and/or "TONE" control knobs are removed or the tone board is serviced, the following procedure should be used for knob "setting".

1. Connect 8 ohm load to both channel "A" and "B" "MAIN" speaker outputs.
2. Connect A.C. V.T.V.M. (or distortion analyzer) to "REMOTE" speaker terminals.
3. Connect Audio Generator thru a "Y" adaptor to both channel "A" and "B" "AUX 1" inputs, and set Generator output to minimum.
4. Set Model 19 controls as follows: Power-on, Volume-MAXIMUM (C.W.), Selector-"AUX 1", Speaker switch-"BOTH", All push buttons-out, Balance and Tone Controls-approximately centered.
5. Set Audio Generator to 2 KHz and adjust output for a reading of 1 to 2 volts on V.T.V.M. on channel "A" speaker terminals. (Note: Exact output voltage is not critical. Use any voltage in the above range which will give you an output exactly on a "dB" marking).
6. Slip "rear" knobs on tone control shafts but DO NOT tighten.
7. Switch generator to 20 KHz and adjust "TREBLE" control for the same output obtained at 2 KHz.
8. Switch Generator to 20 Hz and adjust "BASS" control for the same output obtained at 2 KHz.
9. Alternate between the three frequencies (20 Hz, 2 KHz and 20 KHz) and readjust tone controls until exactly the same output is obtained at all three frequencies. (Note: Monitor Generator output at all three frequencies for constant output. If it's not constant, monitor with separate V.T.V.M. and adjust output to same level at each of the three frequencies.)
10. CAREFULLY install front tone control knobs and "lock" in place with "NOTCH" lined up with the "DOT" on front panel.
11. Repeat steps 5, 7, 8 and 9 for channel "B". Note: Front knobs (just set) may be used to turn channel "B" controls as they are "CLUTCHED" together.
12. CAREFULLY set rear knobs and "lock" in place with "NOTCH" lined up with the "DOT" on front panel.
13. Set both channel "A" and "B" tone control knobs to the flat position (All four "NOTCHES" lined up with dots.) and set Generator to 2 KHz.
14. Adjust the "BALANCE" control for equal outputs on both channels.
15. CAREFULLY install "BALANCE" knob and "LOCK" in place with the "NOTCH" lined up with the "DOT" on the front panel.
16. This completes the setting and the Model 19 is now "FLAT" in the "FLAT" position. Balance within ± 3 dB is also now maintained at any setting of the volume control from full output to -50 dB.



ALL VOLTAGES SHOWN ARE $\pm 10\%$ (UNLESS OTHERWISE NOTED) TAKEN WITH A DC VTVM HAVING AN INPUT IMPEDANCE OF 200 MEG-OHMS AND AN AC VTVM HAVING AN INPUT IMPEDANCE OF 1 MEGOHM: LINE VOLTAGE EQUALS 120 VAC AT 60 HZ.

UNLESS OTHERWISE NOTED:
ALL RESISTORS ARE IN OHMS $\frac{1}{4}W$ 5%
ALL CAPACITORS IN DECIMALS AND LESS THAN 1 ARE μF .
ALL OTHER CAPACITORS ARE PF
*ALL INDUCTORS ARE IN μH .

FIGURE 17A - DRIVER SCHEMATIC DIAGRAM

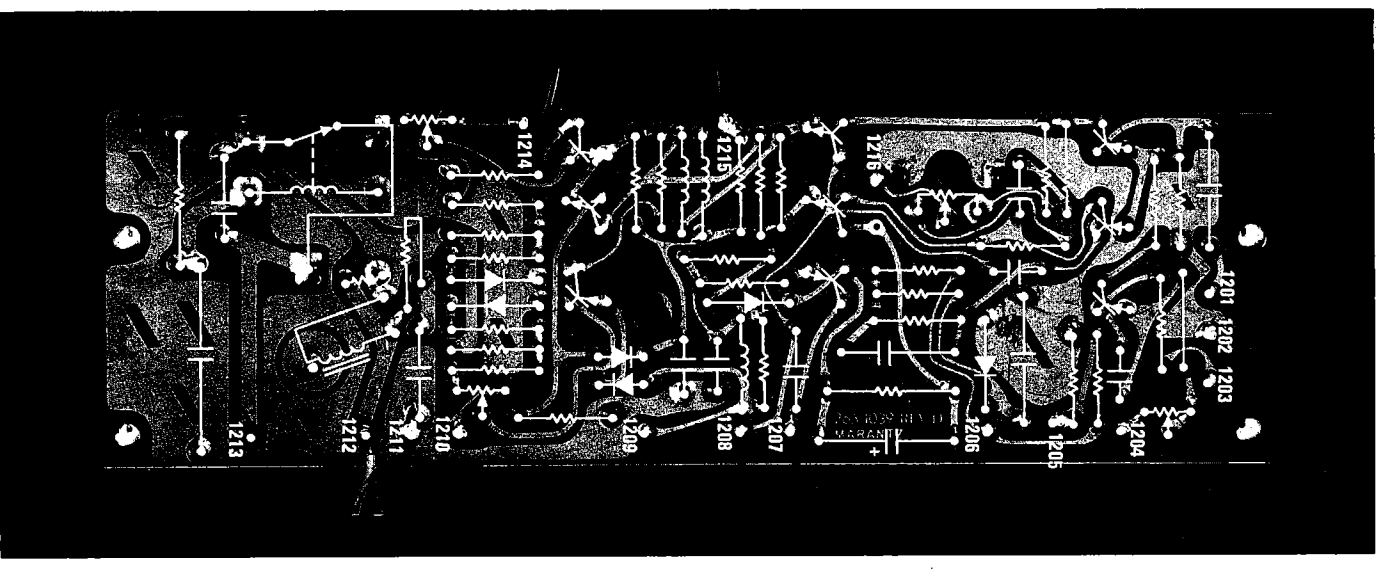

FIGURE 17B - DRIVER CONDUCTOR DIAGRAM

- SIGNAL PATH
- FEEDBACK PATH
- DIFFERENTIAL SIGNAL
- VOLTAGE

THE PARTS LIST FOR THIS UNIT IS LOCATED ON PAGE 84.

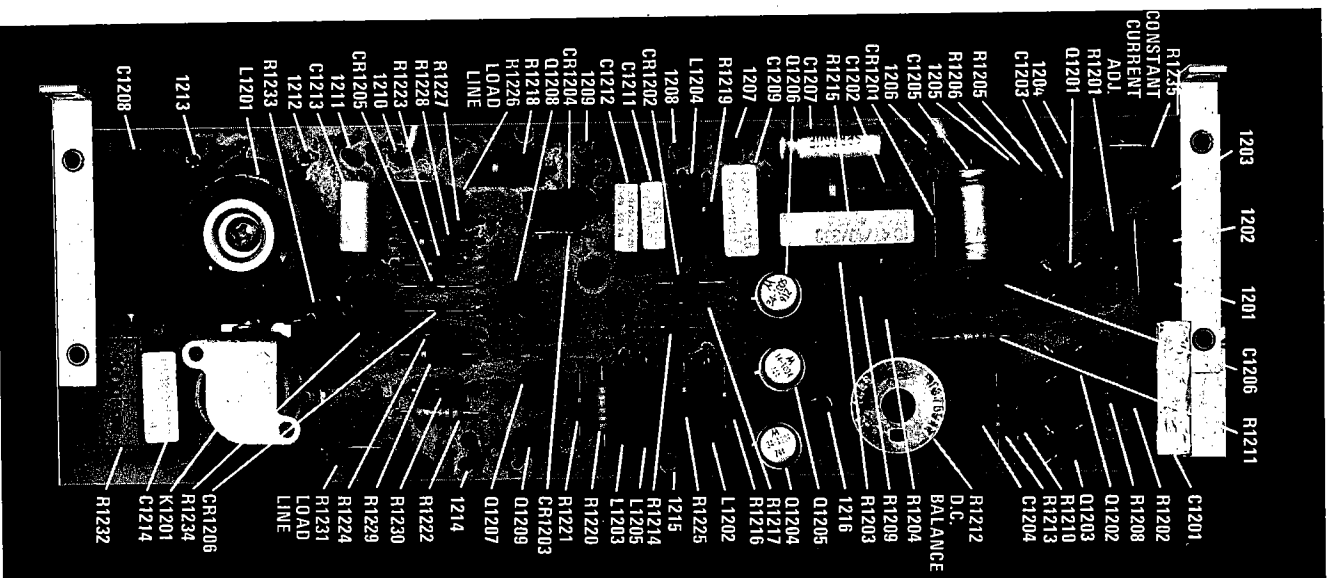

FIGURE 17C — DRIVER COMPONENT DIAGRAM

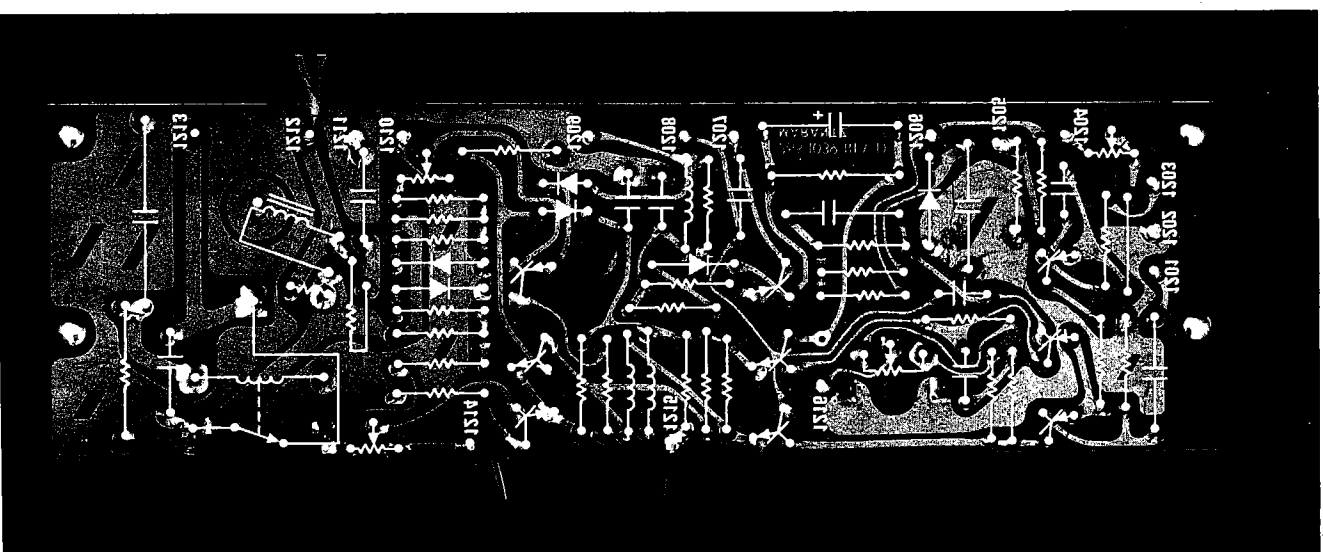

FIGURE 17D — DRIVER CONDUCTOR PATTERN DIAGRAM (AS VIEWED FROM THE COMPONENT SIDE OF BOARD)

REFER TO PAGE 59 FOR A FUNCTIONAL RELATION DIAGRAM OF THE DRIVERBOARD AND THE POWER AMP BOARD.

DRIVER BOARD ADJUSTMENTS

PRELIMINARY SET UP

1. Connect 8 ohm load to channel "A" and "B" "MAIN" speaker terminals.
2. Connect Audio Generator to "AUX 1" input with output level to minimum.
3. Set Model 19 controls as follows: Selector "AUX 1", Volume-Maximum C.W., Balance and Tone controls-Center, all push buttons-out, except mono (L+R).
4. Connect measurement equipment, *i.e.*, meters, distortion analyzer, to "REMOTE" speaker terminals when connection is called for as "OUTPUT."

D.C. BALANCE

1. Connect D.C. Voltmeter to "A" "OUTPUT" terminals.
2. Set speaker switch to "BOTH" position and selector switch to "AUX-2."
3. Adjust channel "A" R1212 for 0 ±10 mV.
4. Move D.C. Voltmeter to "B" "OUTPUT" terminals and adjust channel "B" R1212 for 0 ±10 mV. Note: If D.C. "BALANCE" cannot be obtained, interchange Q1201, Q1202 and Q1203. Be sure to try all possible combinations of placement of the three devices. If D.C. balance still cannot be obtained see TROUBLE ANALYSIS section of this manual.

CONSTANT CURRENT SETTING AND DISTORTION CHECK

1. Connect distortion analyzer to "A" "OUTPUT" terminals.
2. Set speaker switch to "BOTH" position and selector switch to "AUX-1."
3. Turn R1226 and R1231 fully C.W. on BOTH channel "A" and "B" driver boards.
4. Set audio generator to 20 Hz and adjust level for 20 volts at "OUTPUT" terminals.

5. Set analyzer for distortion reading and operate it on the 0.3% (full scale) range.

6. Adjust R1235 on channel "A" full C.C.W. then turn C.W. slowly until severe distortion just starts to occur. Stop and turn R1235 C.C.W. approximately 15 degrees. The distortion at this point should be below 0.15%.
7. Move distortion analyzer to channel "B" "OUTPUT" and repeat step No. 6 on channel "B" board. Note: Recheck channel "A" as there is some interaction between channels.
8. Switch audio generator and distortion analyzer to 20 KHz and check distortion. It should read less than 0.15%.

LOAD LINE PROTECTION

1. Set audio generator to 20 Hz.
2. Set speaker switch to "REMOTE." (Disconnects load.)
3. Connect distortion analyzer to channel "A" "OUTPUT," and set to 30 volt range.
4. Adjust audio generator for 23 volts on distortion analyzer (or V.T.V.M.).
5. Set distortion analyzer to read 20 Hz distortion.
6. On channel "A" driver board, adjust R1226 and R1231 individually C.C.W. to a point just prior to where distortion starts to rise.
7. Switch analyzer to channel "B" "OUTPUT" and repeat adjustments in step No. 6 on channel "B" board.
8. Recheck both channels for any interaction and readjust as necessary.
9. Seal all above adjustments (after checking power amplifier bias adjustment) with Duco household cement or G.C. Radio-T.V. service cement No. 30-2. Apply sparingly - DO NOT use Glyptol or other "sealing compounds" as they may damage the "pots" permanently.

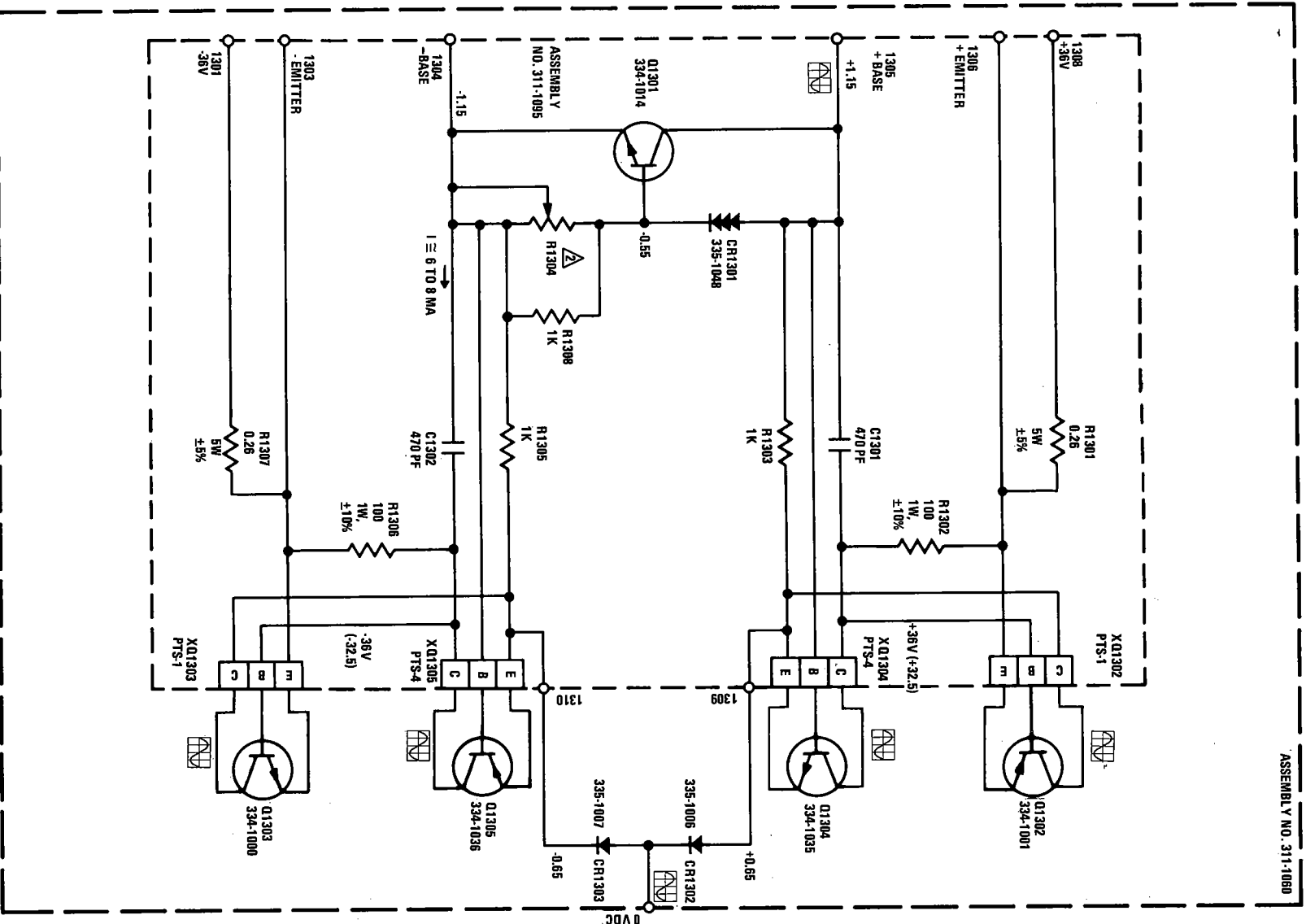

FIGURE 18A - POWER AMP SCHEMATIC DIAGRAM

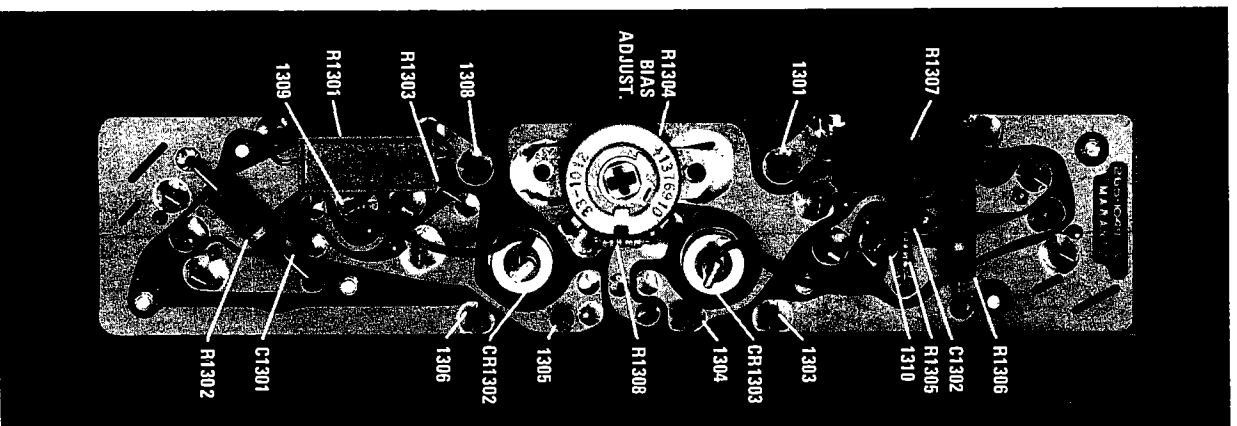

FIGURE 18B - POWER AMP CONDUCTOR DIAGRAM

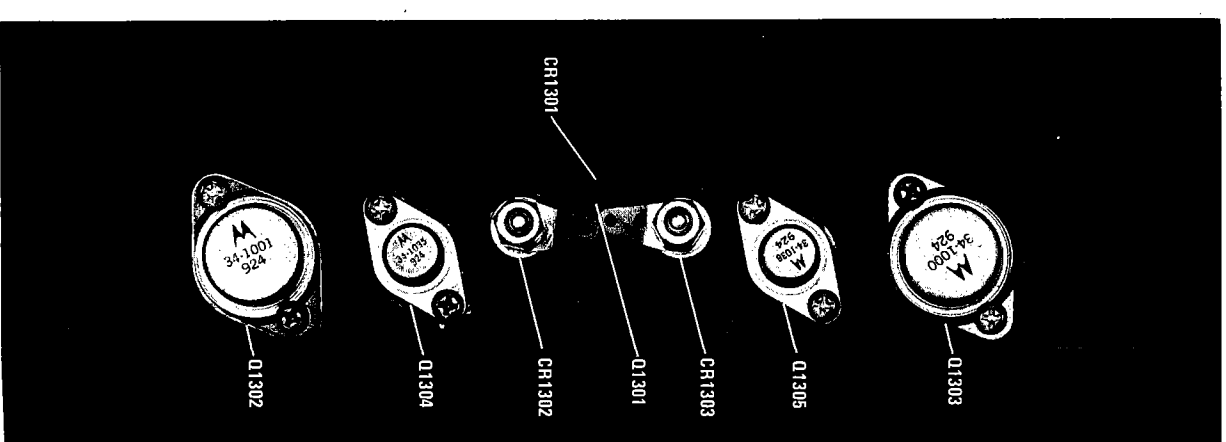

FIGURE 18C - POWER AMP COMPONENT DIAGRAM

ALL VOLTAGES SHOWN ARE $\pm 10\%$ (UNLESS OTHERWISE NOTED) TAKEN WITH A DC VTVM HAVING AN INPUT IMPEDANCE OF 200 MEG-OHMS AND AN AC VTVM HAVING AN INPUT IMPEDANCE OF 1 MEGOHM. LINE VOLTAGE EQUALS 120 VAC AT 60 HZ.

UNLESS OTHERWISE NOTED:
 ALL RESISTORS ARE IN OHMS $\frac{1}{2}W$ 5%
 ALL CAPACITORS IN DECIMALS AND LESS THAN 1 ARE μF .
 ALL OTHER CAPACITORS ARE PF
 *ALL INDUCTORS ARE IN μH

- 1 Δ R1304 IS 2.5K $\pm 20\%$ W.W. LINEAR TAPER, WITH A 220 Ω $\pm 30\%$ STOP ON CW END.
- 2 VOLTAGES IN PARENTHESES ARE WITH BOTH CHANNELS DRIVER AT 1 KHz @ 50W RMS INTO AN 8 OHM LOAD.
- 3 WAVEFORMS ARE SHOWN FOR APPROXIMATE PHASE RELATIONSHIP ONLY.
- 4 IDLING CURRENT IS ≈ 77 MA.

THE PARTS LIST FOR THIS UNIT IS LOCATED ON PAGE 85.

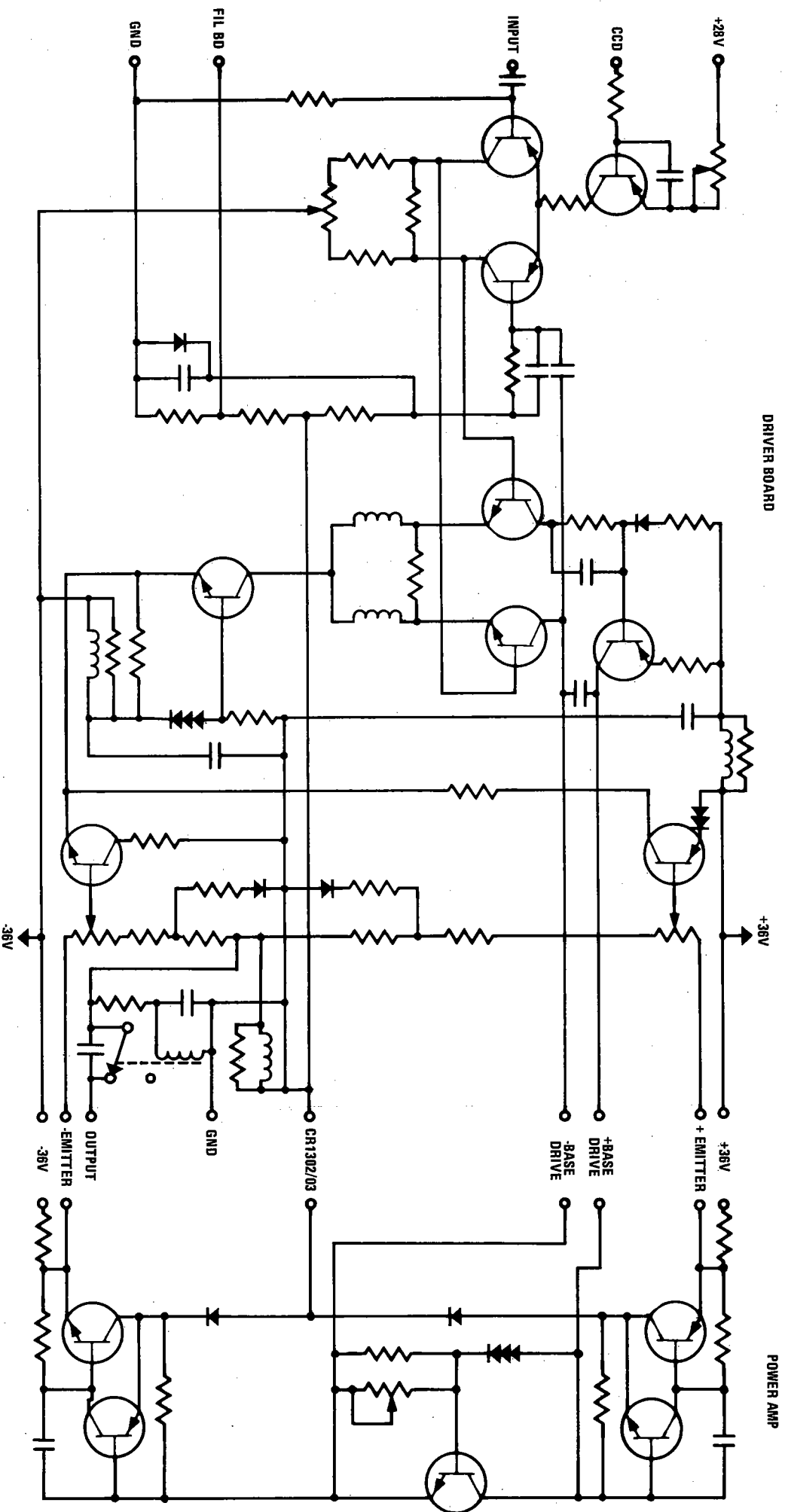

THIS IS A FUNCTIONAL RELATION DIAGRAM OF THE DRIVER BOARD AND THE POWER AMP.

POWER AMPLIFIER ADJUSTMENT (BIAS)

NOTE

MAKE SURE ALL DRIVER BOARD ADJUSTMENTS HAVE BEEN MADE BEFORE PRECEDING WITH THIS ADJUSTMENT.

1. Bias adjustment may be made with or without a load on the speaker outputs.
2. Apply no inputs. Set volume to full C.C.W. (off) and power OFF.
3. Connect a D.C. V.T.V.M. with a 0.1 volt (full scale) range across R1301 or R1307 (R1307 can be connected across on the driver board at pins 1215-violet wire (-) and 1214-gray wire (+) near top of board.
4. Adjust respective bias pots R1304 for 20 mV. on D.C. V.T.V.M.
5. Check distortion at 20 KHz. It must be less than 0.15%.

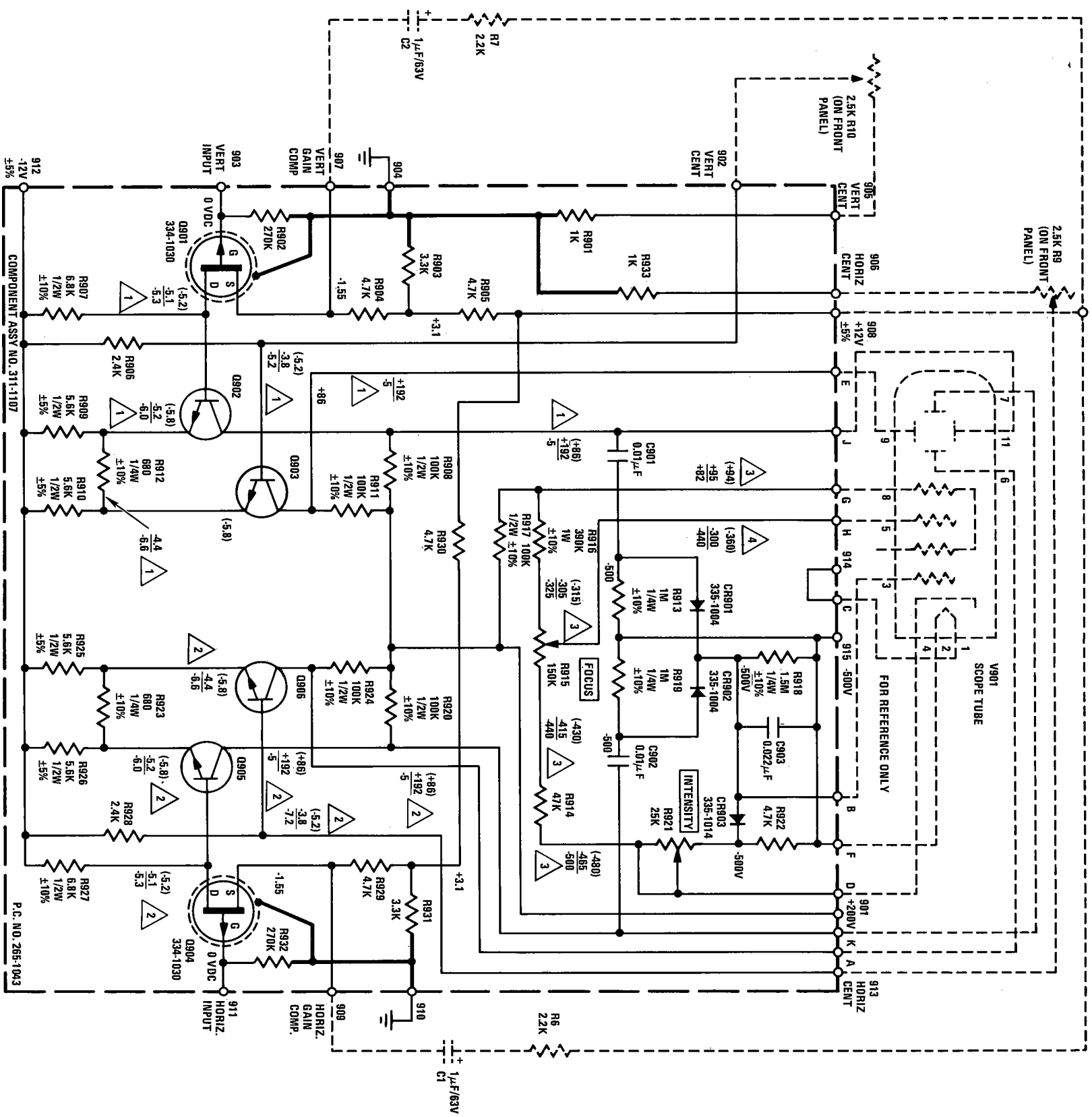

FIGURE 19A - SCOPE SCHEMATIC DIAGRAM

▲ +192/5 READINGS INDICATE THE TOTAL VOLTAGE RANGES ENCOUNTERED WITH THE VERTICAL POSITION POT SET AT ITS TWO EXTREMES.
 ▲ +192/5 READINGS INDICATE THE TOTAL VOLTAGE RANGES ENCOUNTERED WITH THE HORIZONTAL POSITION POT SET AT ITS TWO EXTREMES.

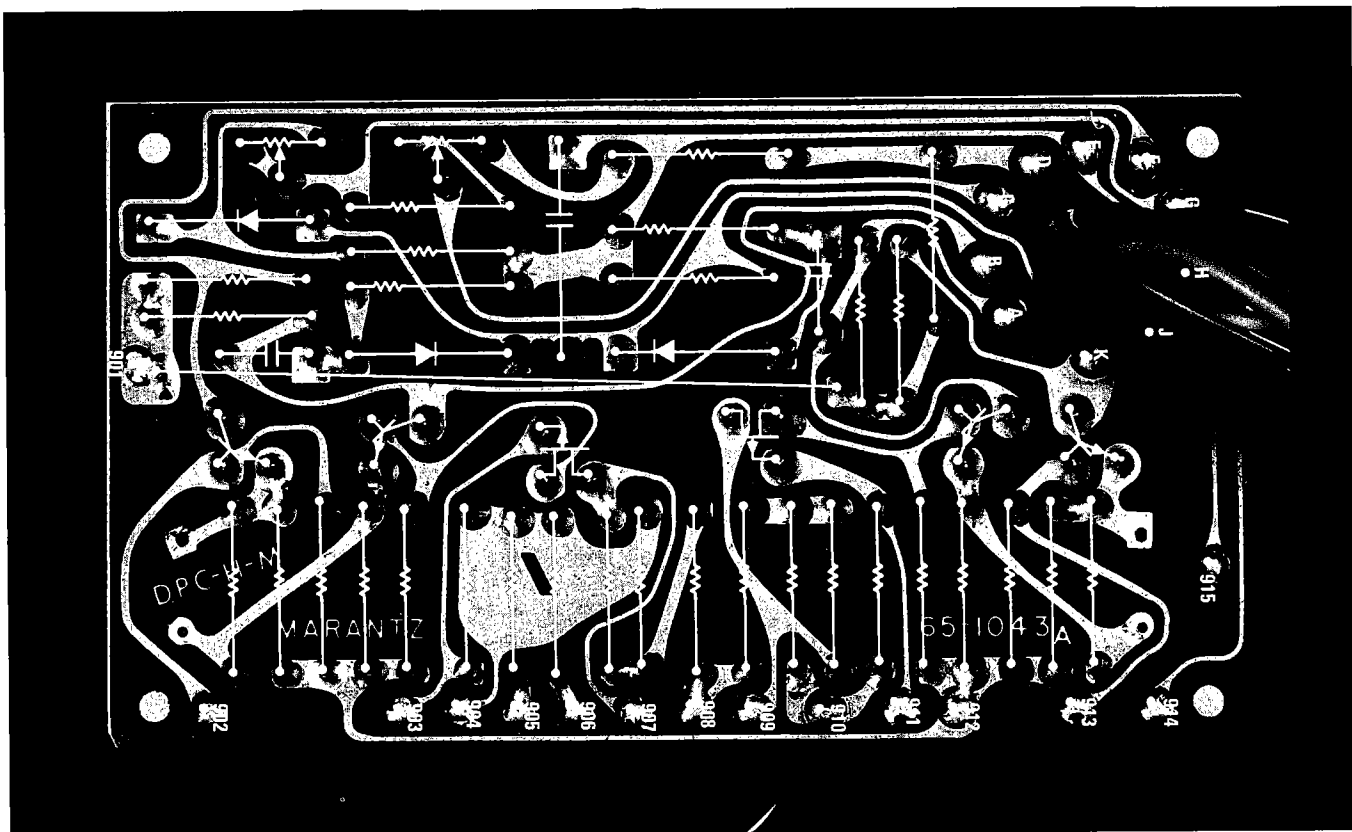

FIGURE 19B - SCOPE CONDUCTOR DIAGRAM

▲ 415/440 READINGS INDICATE THE TOTAL VOLTAGE RANGES ENCOUNTERED WITH THE INTENSITY CONTROL POT SET AT ITS TWO EXTREMES.
 ▲ 300/440 READINGS INDICATE THE TOTAL VOLTAGE RANGE ENCOUNTERED WITH BOTH THE INTENSITY AND FOCUS POTS SET TO EITHER OF THEIR TWO EXTREMES.
 ▲ VOLTAGES SHOWN IN PARENTHESES (+80) ARE APPROXIMATE FOR NORMAL OPERATION WITH SMALL DOT ● ONLY DISPLAYED AT CENTER OF CRT.

ALL VOLTAGES SHOWN ARE $\pm 10\%$ (UNLESS OTHERWISE NOTED) TAKEN WITH A DC VTVM HAVING AN INPUT IMPEDANCE OF 200 MEG-OHMS AND AN AC VTVM HAVING AN INPUT IMPEDANCE OF 1 MEGOHM. LINE VOLTAGE EQUALS 120 VAC AT 60 Hz.
 UNLESS OTHERWISE NOTED:
 ALL RESISTORS ARE IN OHMS $\frac{1}{2}W$ 5%
 ALL CAPACITORS IN DECIMALS AND LESS THAN 1 ARE μF
 ALL OTHER CAPACITORS ARE pF
 *ALL INDUCTORS ARE IN μH

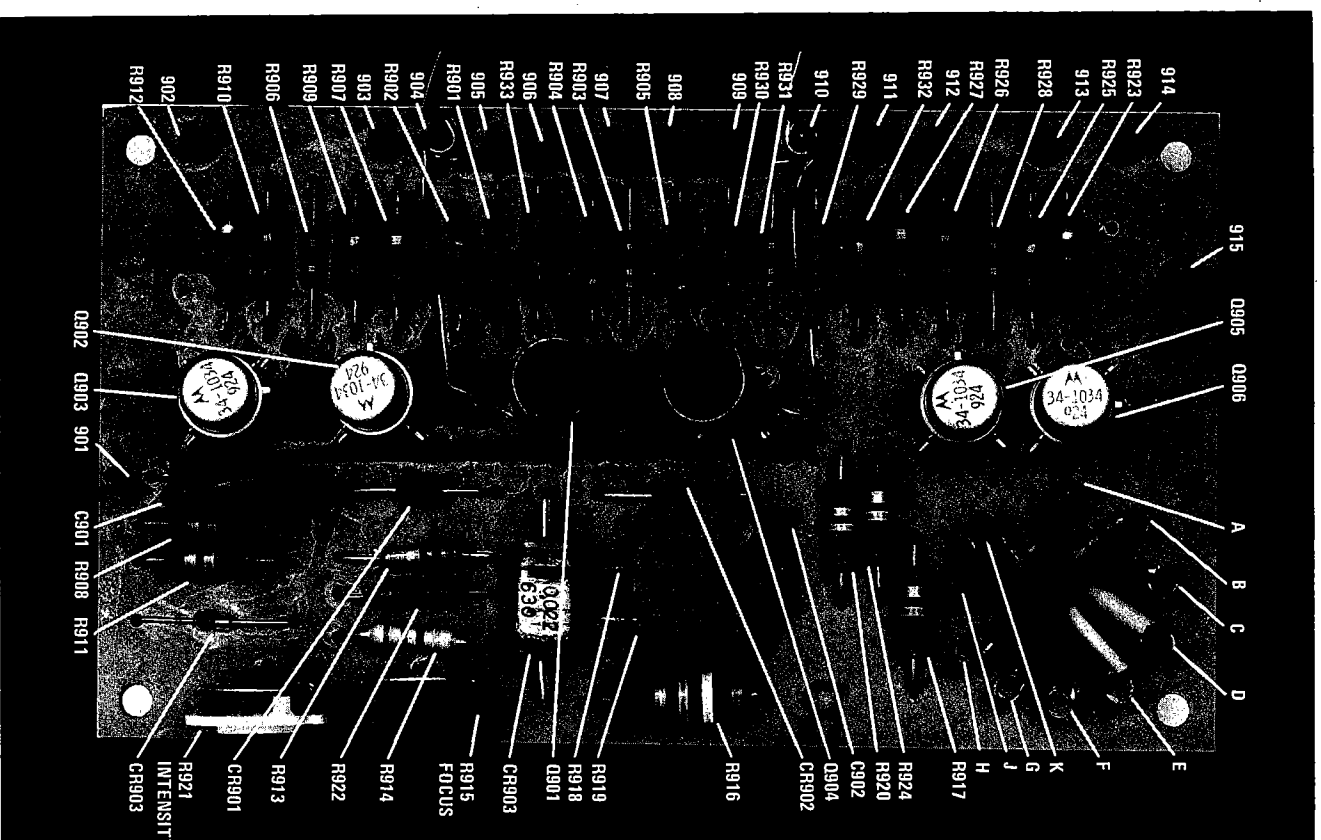

FIGURE 19C - SCOPE COMPONENT DIAGRAM

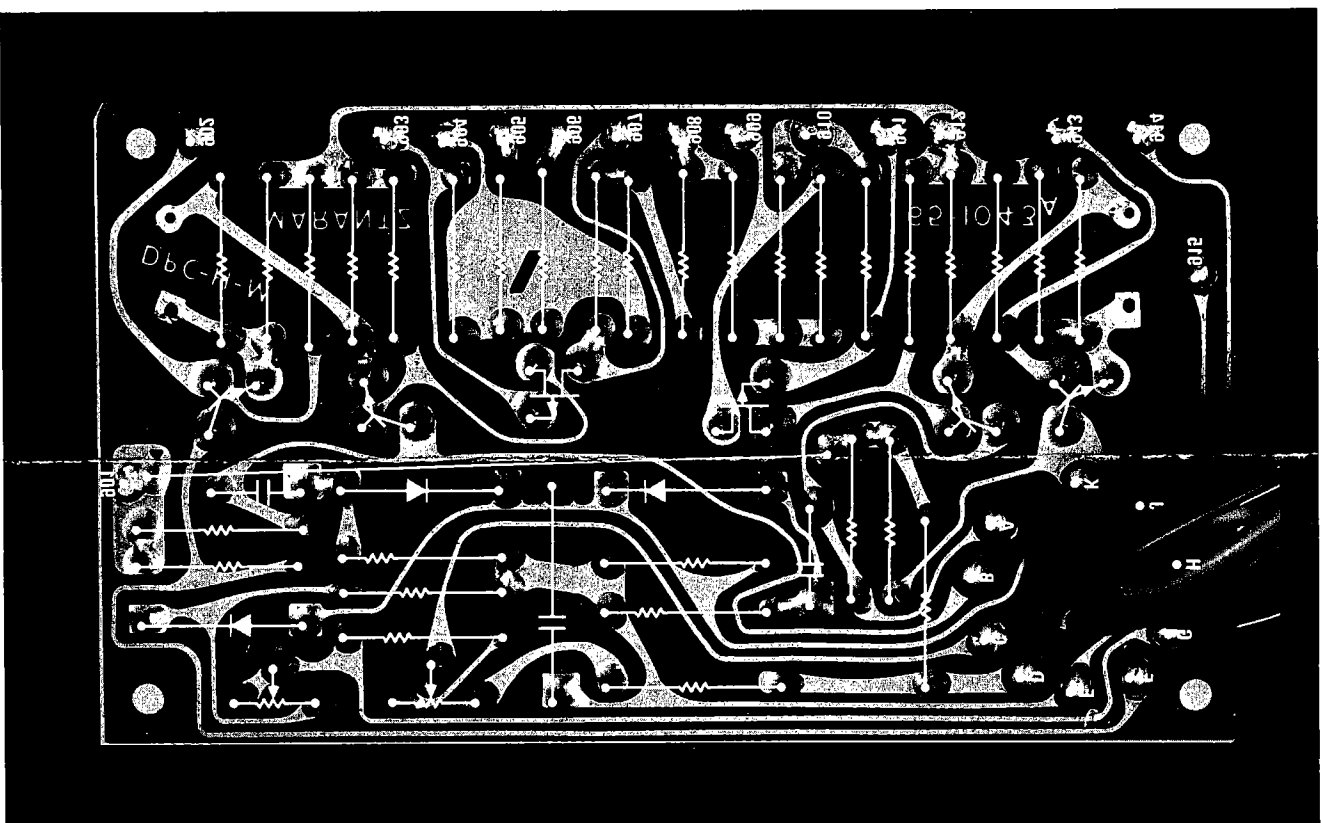

FIGURE 19D - SCOPE CONDUCTOR PATTERN DIAGRAM
(AS VIEWED FROM THE COMPONENT SIDE OF BOARD)

SCOPE BOARD ADJUSTMENTS

CAUTION: HIGH VOLTAGES on the SCOPE BOARD can EQUAL or EXCEED 700 VOLTS. EXTREME CARE should be used when working here.

1. Turn on Model 19 receiver and allow to "warm up" for approximately 5 to 10 minutes.
2. Connection of inputs or outputs are unnecessary.
3. Press "SCOPE ON" push button.
4. Set the "INTENSITY" pot (white) fully C.W. (as viewed from plastic disc side of pot).
5. Set the "FOCUS" pot (red) fully C.C.W. (as viewed from plastic disc side of pot). Caution: Use an INSULATED SCREWDRIVER for ALL ADJUSTMENTS since both pots are "LIVE" with HIGH VOLTAGE.
6. Press the "TAPE MONITOR" push button (all others except "SCOPE ON" should be out).
7. Center the "spot" on the screen of the C.R.T. with the VERT. and HORZ. centering controls on the front panel. (The "spot" will be bright, large and "fuzzy" making it easy to locate.)
8. Turn the "FOCUS" pot (red) C.W. until trace becomes a small sharp dot.
9. Turn the intensity pot (white) C.C.W. until dot is just barely visible.
10. Press "tuning" pushbutton (Note: selector should be in "AUX 1" or "AUX 2" position - any but "FM") and recheck focus and readjust if necessary. The vertical bar should be clearly visible. If not, increase intensity slightly.

THE PARTS LIST FOR THIS UNIT IS LOCATED ON
PAGE 87.

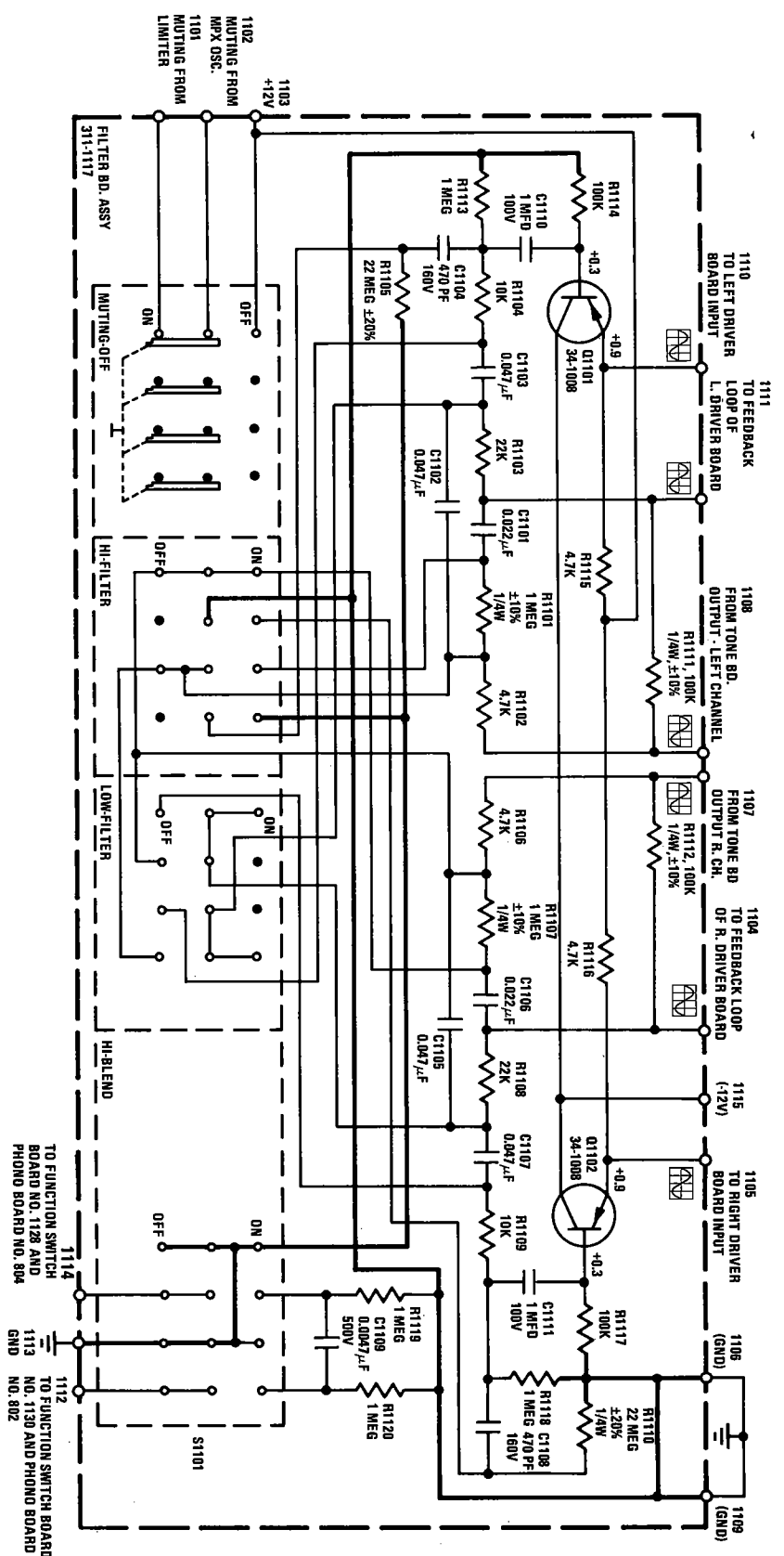

FIGURE 20A - HI-LOW FILTER (NEW) SCHEMATIC DIAGRAM

AC WAVEFORMS ARE SHOWN FOR APPROXIMATE PHASE RELATIONSHIP ONLY.

ALL VOLTAGES SHOWN ARE $\pm 10\%$ (UNLESS OTHERWISE NOTED) TAKEN WITH A DC VTVM HAVING AN INPUT IMPEDANCE OF 200 MEG-OHMS AND AN AC VTVM HAVING AN INPUT IMPEDANCE OF 1 MEGOHM. LINE VOLTAGE EQUALS 120 VAC AT 60 Hz.

UNLESS OTHERWISE NOTED:
 ALL RESISTORS ARE IN OHMS $\frac{1}{4}W$ 5%
 ALL CAPACITORS IN DECIMALS AND LESS THAN 1 ARE μF ,
 ALL OTHER CAPACITORS ARE PF
 *ALL INDUCTORS ARE IN μH

THE PARTS LIST FOR THIS UNIT IS LOCATED ON PAGE 83.

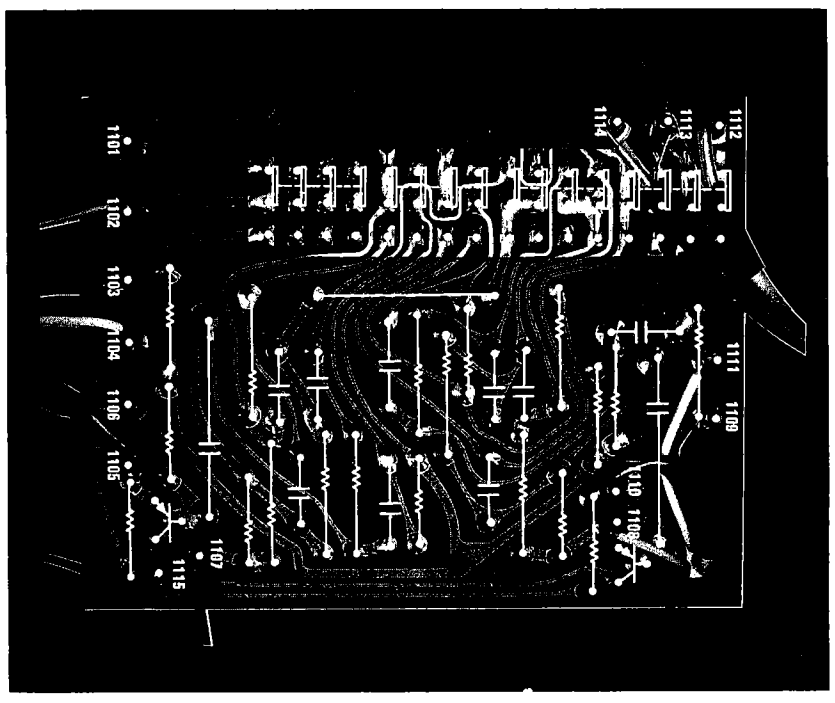

FIGURE 20B - HI-LOW FILTER (NEW) CONDUCTOR DIAGRAM

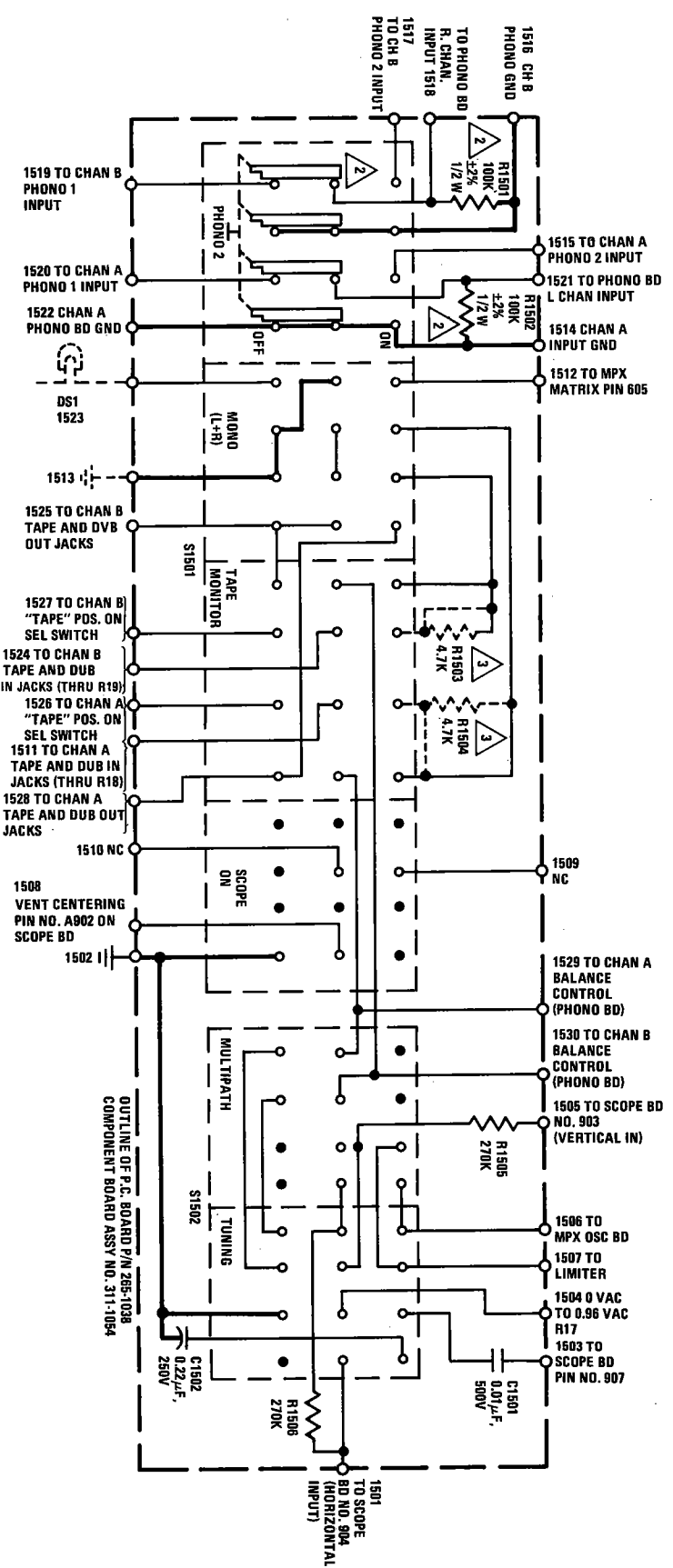

FIGURE 21A - FUNCTION SWITCH SCHEMATIC DIAGRAM

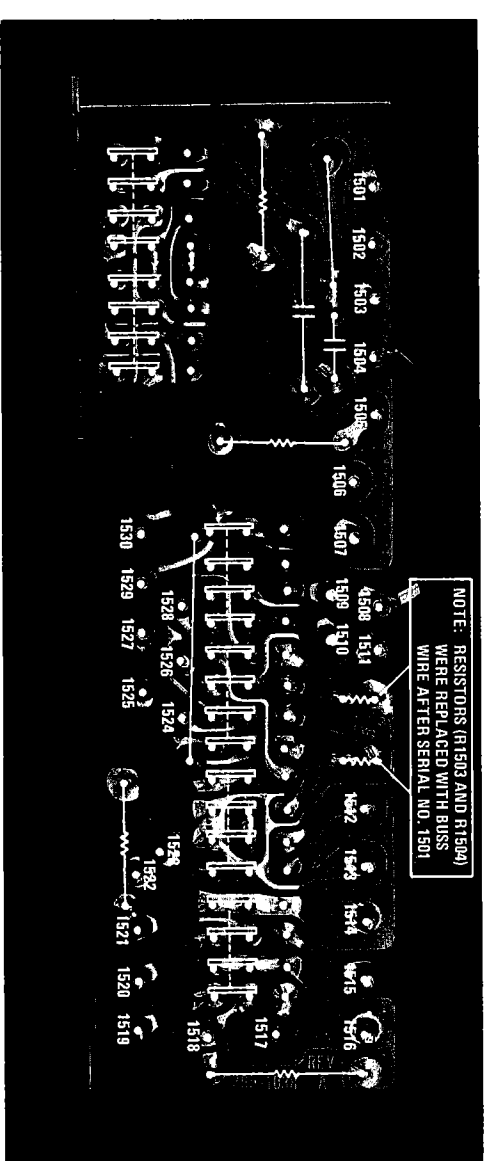

FIGURE 21B - FUNCTION SWITCH CONDUCTOR DIAGRAM

THE PARTS LIST FOR THIS UNIT IS LOCATED ON PAGE 87.

- 1. TYPICAL PUSHBUTTON SWITCH, 6 PLACES.
- 2. R1501 AND R1502 WERE $47K$, $\pm 10\%$, $1/4$ WATT PRIOR TO S/N 1501.
- 3. R1503 AND R1504 WERE REMOVED AT S/N 1501 - REPLACED WITH BUSS WIRE ON P.C. BOARD.

UNLESS OTHERWISE NOTED:
 ALL RESISTORS ARE IN OHMS $\frac{1}{4}W$ 5%
 ALL CAPACITORS IN DECIMALS AND LESS THAN 1 ARE μF ,
 ALL OTHER CAPACITORS ARE PF
 *ALL INDUCTORS ARE IN μH

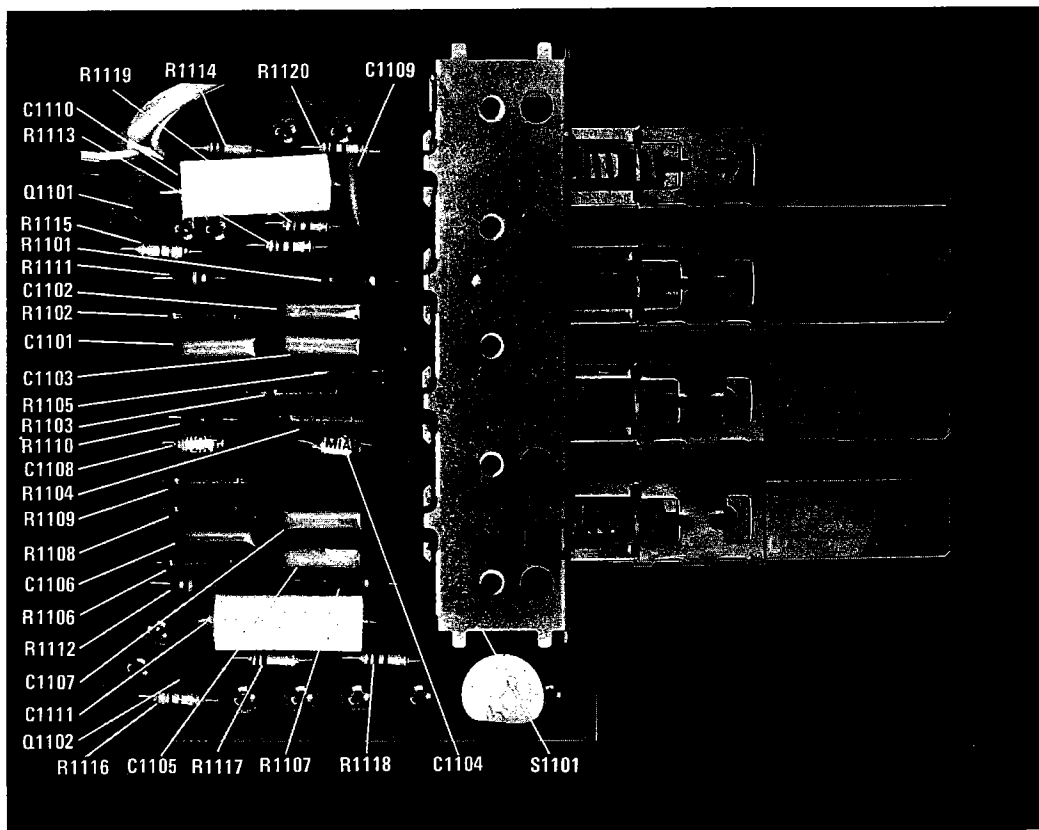

FIGURE 20C – HI-LOW FILTER (NEW) COMPONENT DIAGRAM

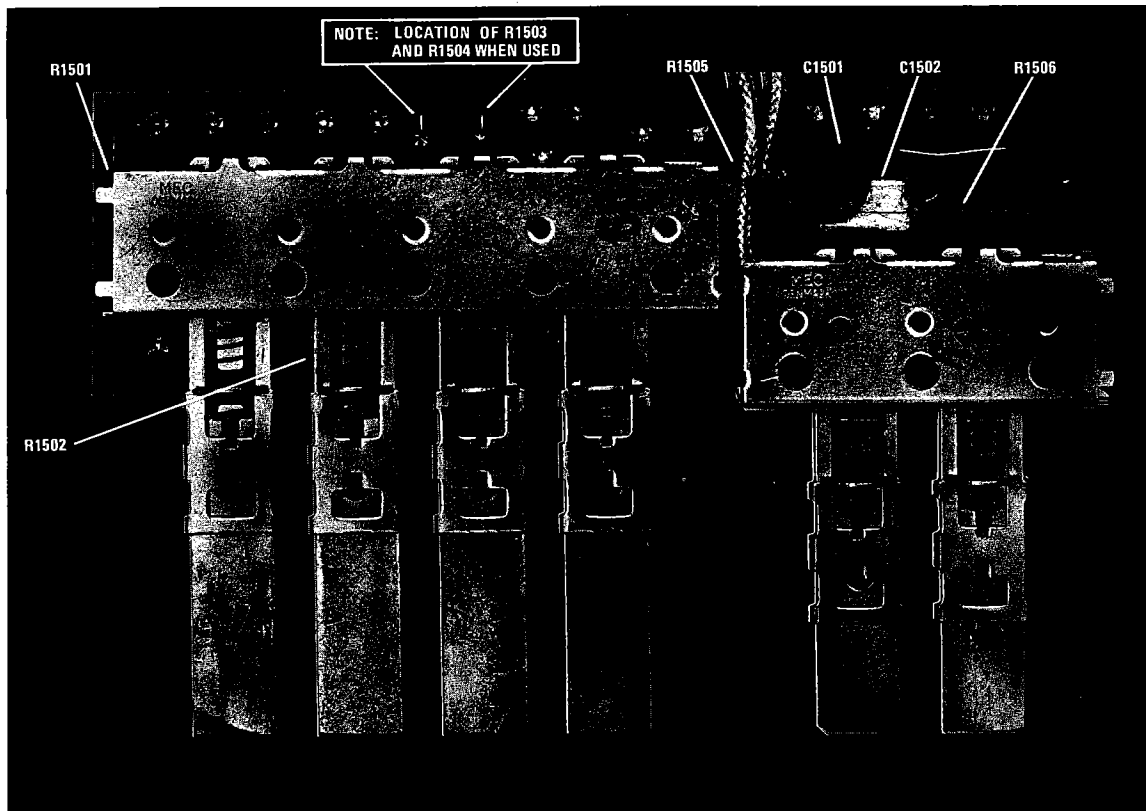

FIGURE 21C – FUNCTION SWITCH COMPONENT DIAGRAM

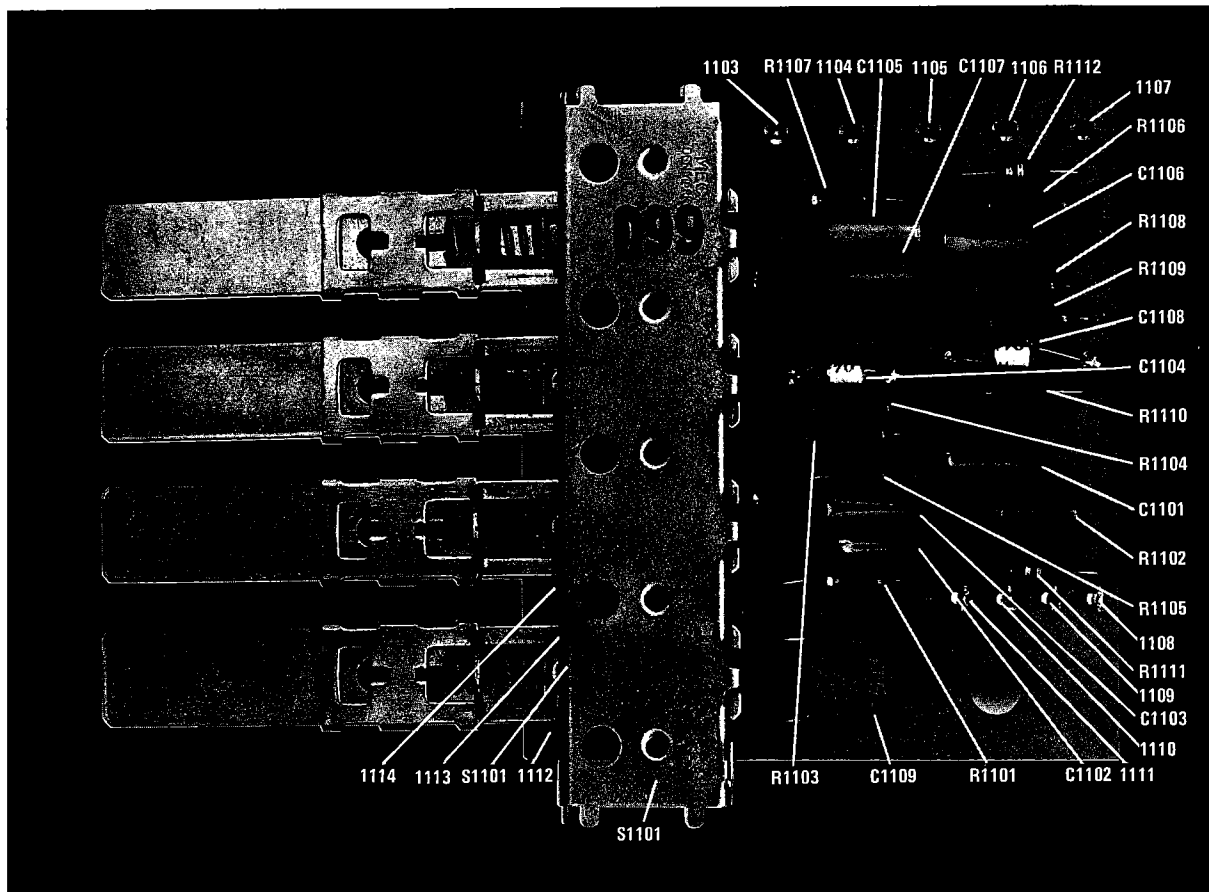

FIGURE 22A – HI-LOW FILTER (OLD) COMPONENT DIAGRAM

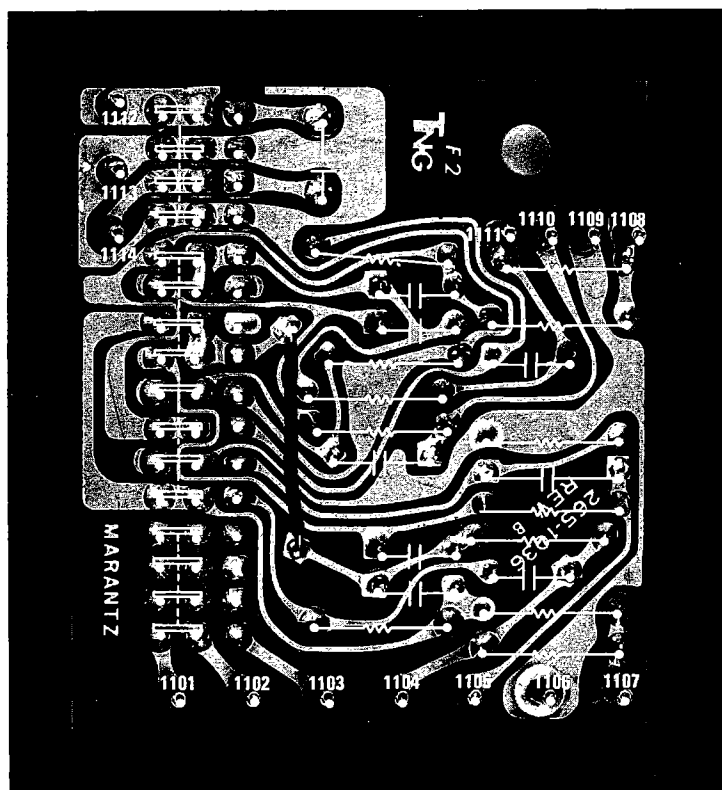

FIGURE 22B – HI-LOW FILTER (OLD) CONDUCTOR DIAGRAM

UNLESS OTHERWISE NOTED:
 ALL RESISTORS ARE IN OHMS ¼W 5%
 ALL CAPACITORS IN DECIMALS AND LESS
 THAN 1 ARE μF ,
 ALL OTHER CAPACITORS ARE pF
 *ALL INDUCTORS ARE IN μH

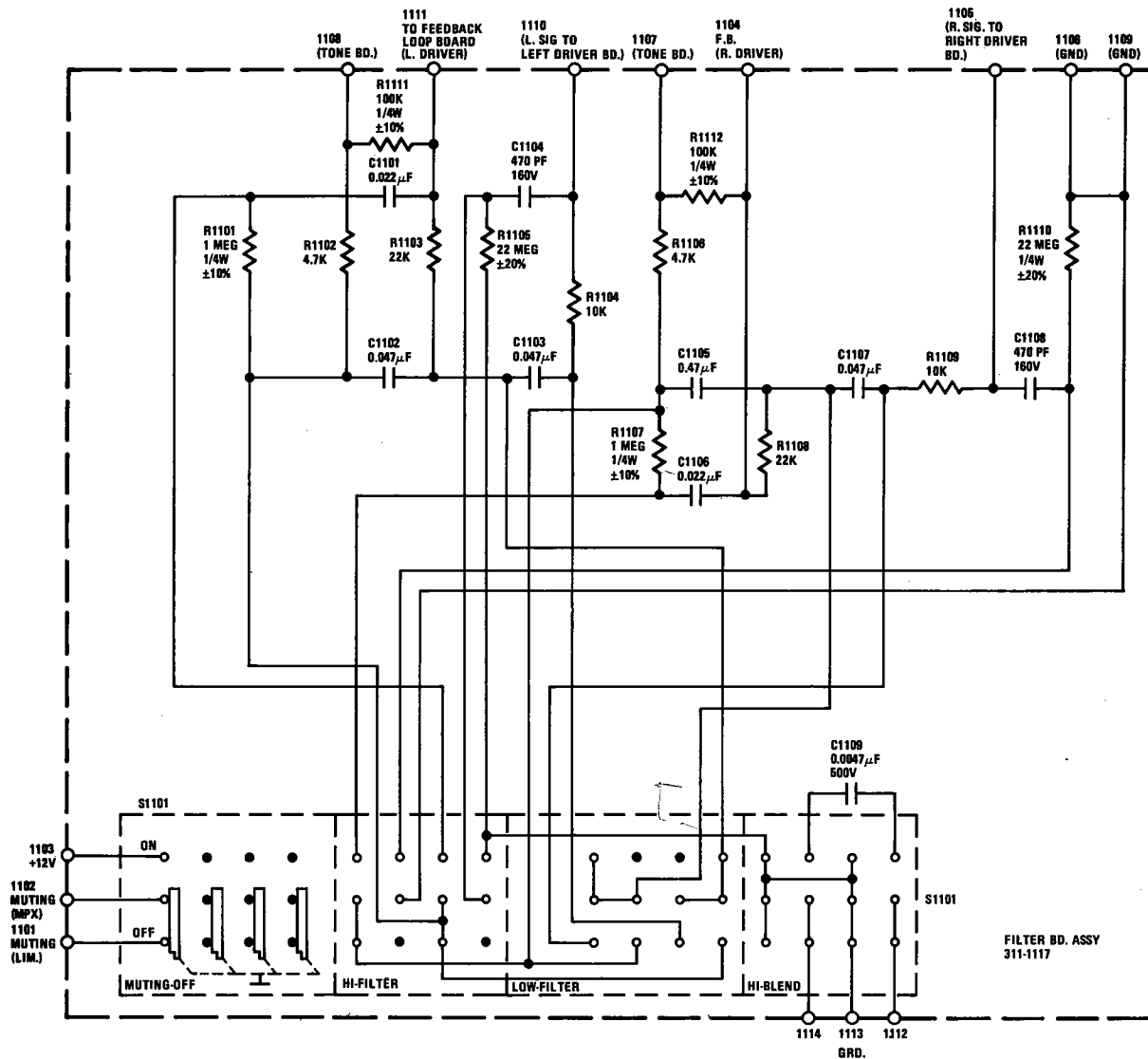

FIGURE 22C – HI-LOW FILTER (OLD) SCHEMATIC DIAGRAM

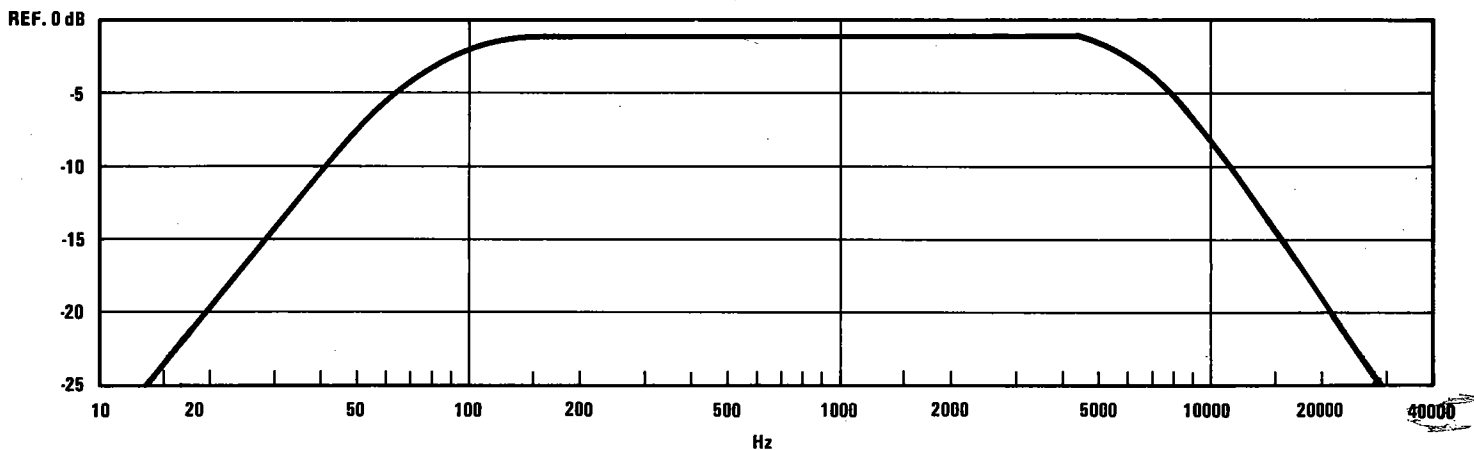







FIGURE 22D – HI-LOW FILTER CURVE

PARTS LIST

Reference Designation	Description and/or Remarks	Marantz Part Number
A1	Power Supply Board Complete	311-1041-1
C101	Cap. Elect., 20 MFD at 250VDC & 20 MFD at 250VDC	318-1010
C102	Cap. Elect., 250 MFD at 80VDC & 350MFD at 50VDC	318-1013
C103	Cap. Elect., 350MFD at 50VDC & 350MFD at 15VDC	318-1011
C104	Cap. Elect., 350MFD at 50VDC & 350MFD at 15VDC	318-1012
C105	Cap. Elect., 10MFD at 350VDC	318-1017
C106	Cap. Elect., 10MFD at 350VDC	318-1017
CR101	Rect. Silicon, H.V., 1500PIV	335-1015
CR102	Rect. Silicon, 600PIV, 1A	335-1003
CR103	Rect. Silicon, 600PIV, 1A	335-1003
CR104	Rect. Silicon, 200PIV, 1A	335-1004
CR105	Rect. Silicon, 200PIV, 1A	335-1004
CR106	Diode, 3A, 200PIV	335-1042
CR107	Diode, 3A, 200PIV	335-1043
CR108	Diode, 3A, 200PIV	335-1043
CR109	Diode, 3A, 200PIV	335-1042
CR110 	Zener, Rect., 36V, $\pm 1\%$, 5W	459-1007
CR111	Zener, Rect., 12V, $\pm 5\%$, 3W	335-1012
CR112	Zener, Rect., 12V, $\pm 5\%$, 3W	335-1012
R101 	Res., 220ohm, $\pm 5\%$, 1W	423-3222
R102	Res., 2.2K, $\pm 10\%$, 1W	326-1000
R103 	Res., 330ohm, $\pm 5\%$, 1W	326-1186
R104	Res., 80ohm, $\pm 5\%$, 5W	329-1010
R105	Res., 80ohm, $\pm 5\%$, 5W	329-1010
R106	Res., 80ohm, $\pm 5\%$, 5W	329-1010
R107	Res., 80ohm, $\pm 5\%$, 5W	329-1010

Reference Designation	Description and/or Remarks	Marantz Part Number
	P.C. Board Only	265-1037
	Spacer (P.C. Bd. to Cover)	279-1032
	Spacers (P.C. Bd. to Chassis)	279-1034
	Cover Plate	295-1209

 R101 and R103 were 430 ohms, 2 watts, $\pm 5\%$, P/N 326-1015, prior to S/N 1501.

 CR110 was P/N 335-1013 Zener, Rect. 36V, $\pm 5\%$, 3 watt, prior to S/N 1501.

Reference Designation	Description and/or Remarks	Marantz Part Number
A2	Front End Assembly - Complete	311-1073-1
C201	Cap., 1000PFD, $\pm 20\%$, Feed-Thru	322-1000
C202	Cap., .01MFD, $\pm 20\%$, 100V	134-1068
C203	Cap., 1000PFD, $\pm 20\%$, Feed-Thru	322-1000
C204	Cap., 1000PFD, $\pm 20\%$, Feed-Thru	322-1000
C205	Cap., .005 MFD, $\begin{matrix} +80\% \\ -20\% \end{matrix}$, 100V	314,1014
C206	Cap., 1000PFD, Stand off	322-1004
C207	Cap., 1000PFD, Stand off	322-1004
C208	Cap., 1000PFD, Stand off	322-1004
C209	Cap., 6.8PFD, $\pm 5\%$, 1000V	314-1066
C210	Cap., Trimmer, 1-12PFD	321-1014
C211	Cap., Variable	324-1002
C212	Cap., 6.8PFD, $\pm 5\%$, 1000V	314-1066
C213	Cap., Trimmer, 1-12PFD	321-1014
C214	Cap., 1000PFD, $\pm 20\%$, Feed-Thru	322-1000
C215	Cap., 15PFD, $\pm 5\%$, 1000V	314-1033
C216	Cap., 5.6PFD, $\pm 5\%$, 500V	317-1003

Reference Designation	Description and/or Remarks	Marantz Part Number
C217	Cap., 10PFD, $\pm 5\%$, 1000V	314-1070
C218	Cap., Variable, 1.7-11PFD	321-1015
C219	Cap., .005MFD, $+80\%$, -20% , 100V	314-1014
C220	Cap., .005MFD, $+80\%$, -20% , 100V	314-1014
C221	Cap., 6.8PFD, $\pm 5\%$, 1000V	314-1066
CR201 $\triangle 1$	Diode Rectifier (1N914 Type)	335-1014
J201	Phono Jack	269-1004
L201	Coil, Antenna	255-1057
L202	Choke, 55 μ H	255-1009
L203	Choke, 3.9 μ H	255-1023
L204	Choke, 55 μ H	255-1009
L205, L206	Coil Assy., Mixer and R.F.	311-1091
L207	Coil, Oscillator	255-1052
Q201 $\triangle 4$	Transistor, Dual Gate MOSFET	463-1002
Q202	Transistor, PNP	334-1037
Q203	Transistor, FET	334-1040
R201	Res., 47K, $\pm 10\%$, 1/4W	326-1176
R202	Res., 10MEG, 10%, 1/4W	326-1194
R203	Res., 33ohm, $\pm 10\%$, 1/4W	326-1189
R204	Res., 8.2K, $\pm 10\%$, 1/4W	326-1168
R205	Res., 8.2K, $\pm 10\%$, 1/4W	326-1168
R206	Res., 470ohm, $\pm 10\%$, 1/4W	326-1031
R207	Res., 220ohm, $\pm 10\%$, 1/4W	326-1162
R208	Res., 120ohm, $\pm 10\%$, 1/4W	326-1170
R209 $\triangle 2$	Res., 1K, $\pm 5\%$, 1/4W	327-1036
R210 $\triangle 3$	Res., 1K, $\pm 5\%$, 1/4W	327-1036
T201	Transformer, Mixer Output	255-1016
	Output Cable Assy.	292-1038

- $\triangle 1$ CR201 not used prior to S/N 1801.
 $\triangle 2$ R209 was 4.7K P/N 326-1032 prior to S/N 1801.
 $\triangle 3$ R201 was 470 ohms P/N 326-1031 prior to S/N 1655.
 $\triangle 4$ Q201 was P/N 334-1038 prior to S/N 1801.

Reference Designation	Description and/or Remarks	Marantz Part Number
A3	I.F. Assembly - Complete	311-1082-1
C301	Cap. 1000PFD $\pm 20\%$, Feed-Thru	322-1000
C302	Cap. 1000PFD $\pm 20\%$, Feed-Thru	322-1000
C303	Cap. .005MFD $+80\%$, -20% , 100V	314-1014
C304	Cap. .005MFD $+80\%$, -20% , 100V	314-1014
C305	Cap. .005MFD $+80\%$, -20% , 100V	314-1014
C306	Cap. .005MFD $+80\%$, -20% , 100V	314-1014
C307	Cap. .005MFD $+80\%$, -20% , 100V	314-1014
C308	Cap. 100PFD $\pm 10\%$, 1000V	314-1021
C309	Cap. 1000PFD $\pm 20\%$, Feed-Thru	322-1000
C310	Cap. 1.2PFD-10PFD Trimmer	321-1001
C311	Cap. 1.2PFD-10PFD Trimmer	321-1001
C312	Cap. 1000PFD $\pm 20\%$, Feed-Thru	322-1000
C313	Cap. 330PFD $\pm 2\%$, 500V	317-1022
C314	Cap. 330PFD $\pm 2\%$, 500V	317,1022
C315	Cap. 330PFD $\pm 2\%$, 500V	317-1022
C316	Cap. .005MFD $+80\%$, -20% , 100V	314-1014
C317	Cap. .005MFD $+80\%$, -20% , 100V	314-1014
C318	Cap. .005MFD $+80\%$, -20% , 100V	314-1014
C319	Cap. .005MFD $+80\%$, -20% , 100V	314-1014
C320	Cap. 100PFD $\pm 10\%$, 1000V	314-1021
C321	Cap. 1000PFD $\pm 20\%$, Feed-Thru	322-1000

Reference Designation	Description and/or Remarks	Marantz Part Number
C322	Cap. 1.2PFD-10PFD Trimmer	321-1001
C323	Cap. 1.2PFD-10PFD Trimmer	321-1001
C324	Cap. 1000PFD $\pm 20\%$, Feed-Thru	322-1000
C325	Cap. 330PFD $\pm 2\%$, 500V	317-1022
C326	Cap. 330PFD $\pm 2\%$, 500V	317-1022
C327	Cap. 330PFD $\pm 2\%$, 500V	317-1022
C328	Cap. .005MFD $\begin{matrix} +80\% \\ -20\% \end{matrix}$, 100V	314-1014
C329	Cap. .005MFD $\begin{matrix} +80\% \\ -20\% \end{matrix}$, 100V	314-1014
C330	Cap. .005MFD $\begin{matrix} +80\% \\ -20\% \end{matrix}$, 100V	314-1014
C331	Cap. .005MFD $\begin{matrix} +80\% \\ -20\% \end{matrix}$, 100V	314-1014
C332	Cap. 100PFD $\pm 10\%$, 1000V	314-1021
C333	Cap. 1000PFD $\pm 20\%$, Feed-Thru	322-1000
C334	Cap. 1.2PFD-10PFD Trimmer	321-1001
C335	Cap. 1.2PFD-10PFD Trimmer	321-1001
C336	Cap. 1000PFD $\pm 20\%$, Feed-Thru	322-1000
C337	Cap. 330PFD $\pm 2\%$, 500V	317-1022
C338	Cap. 330PFD $\pm 2\%$, 500V	317-1022
C339	Cap. 330PFD $\pm 2\%$, 500V	317-1022
C340	Cap. .005MFD $\begin{matrix} +80\% \\ -20\% \end{matrix}$, 100V	314.1014
C341	Cap. .005MFD $\begin{matrix} +80\% \\ -20\% \end{matrix}$, 100V	314-1014
C342	Cap. .005MFD $\begin{matrix} +80\% \\ -20\% \end{matrix}$, 100V	314-1014
C343	Cap. .005MFD $\begin{matrix} +80\% \\ -20\% \end{matrix}$, 100V	314-1014
C344	Cap. 100PFD $\pm 10\%$, 1000V	314-1021

Reference Designation	Description and/or Remarks	Marantz Part Number
C345	Cap. 100PFD $\pm 10\%$, 1000V	314-1021
C346	Cap. .005MFD $\begin{matrix} +80\% \\ -20\% \end{matrix}$, 100V	314-1014
C347	Cap. 1.2PFD-10PFD Trimmer	321-1001
C348	Cap. 1.2PFD-10PFD Trimmer	321-1001
C349	Cap. 330PFD $\pm 2\%$, 500V	317-1022
C350	Cap. 330PFD $\pm 2\%$, 500V	317-1022
C351	Cap. 330PFD $\pm 2\%$, 500V	317-1022
C352	Cap. 100PFD $\pm 10\%$, 1000V	314-1021
C353	Cap. .01MFD $\pm 20\%$, 100V	314-1068
C354	Cap. 1000PFD $\pm 20\%$, Feed-Thru	322-1000
CR301	Diode	335-1022
CR302	Diode	335-1022
J301 & J302	Phono Jack	269-1004
L301	Choke, 55 μ H	255-1009
L302	Choke, 55 μ H	255-1009
L303	Choke, 55 μ H	255-1009
L304	Choke, 55 μ H	255-1009
L305	Choke, 55 μ H	255-1009
L306	Choke, 55 μ H	255-1009
L307	Coil, Adjustable	255-1055
L308	Coil, Adjustable	255-1055
L309	Coil, Adjustable	255-1055
L310	Choke, 55 μ H	255-1009
L311	Choke, 55 μ H	255-1009
L312	Choke, 55 μ H	255-1009
L313	Choke, 55 μ H	255-1009
L314	Choke, 55 μ H	255-1009
L315	Coil, Adjustable	255-1055
L316	Coil, Adjustable	255-1055
L317	Coil, Adjustable	255-1055
L318	Choke, 55 μ H	255-1009

Reference Designation	Description and/or Remarks	Marantz Part Number
L319	Choke, 55 μ H	255-1009
L320	Choke, 55 μ H	255-1009
L321	Choke, 55 μ H	255-1009
L322	Choke, 55 μ H	255-1009
L323	Coil, Adjustable	255-1055
L324	Coil, Adjustable	255-1055
L325	Coil, Adjustable	255-1055
L326	Choke, 55 μ H	255-1009
L327	Choke, 55 μ H	255-1009
L328	Choke, 55 μ H	255-1009
L329	Coil, Adjustable	255-1055
L330	Coil, Adjustable	255-1055
L331	Coil, Adjustable	255-1055
L332	Choke, 3.9 μ H	255-1023
Q301	Transistor, FET	334-1040
Q302	Transistor, NPN	334-1018
Q303	Transistor, NPN	334-1018
Q304	Transistor, NPN	334-1018
R301	Res. 470K, 10%, 1/4W	326-1193
R302	Res. 1.8K, 5%, 1/4W	326-1025
R303	Res. 3.3K, 5%, 1/4W	326-1027
R304	Res. 2.7K, 5%, 1/4W	326-1026
R305	Res. 1.8K, 5%, 1/4W	326-1025
R306	Res. 33ohm, 10%, 1/4W	326-1189
R307	Res. 2.7K, 5%, 1/4W	326-1026
R308	Res. 2.7K, 5%, 1/4W	326-1026
R309	Res. 1.8K, 5%, 1/4W	326-1025
R310	Res. 33ohm, 10%, 1/4W	326-1189
R311	Res. 2.7K, 5%, 1/4W	326-1026
R312	Res. 2.7K, 5%, 1/4W	326-1026
R313	Res. 1.8K, 5%, 1/4W	326-1025
R314	Res. 33ohm, 10%, 1/4W	326-1189
R315	Res. 2.7K, 5%, 1/4W	326-1026
R316	Res. 5.6K, 5%, 1/4W	326-1036
R317	Res. 2.7K, 5%, 1/4W	326-1026
R318	Res. 220K, 10%, 1/4W	326-1179
R319	Res. 3.3K, 5%, 1/4W	326-1027
R320	Res. 1Meg, 10%, 1/4W	326-1190

Reference Designation	Description and/or Remarks	Marantz Part Number
	P.C. Board Component Assy. - Complete	311-1105-1
	P.C. Board Only	265-1048
	Cover	295-1202
	Shield, Top	295-1040
	Shield, Bottom	295-1041
	Shield, Circuit	295-1043
	Mounting Bracket	295-1199

Reference Designation	Description and/or Remarks	Marantz Part Number
A4	Limiter Assy. - Complete	311-1081-1
C401	Cap., .005MFD, +80% 100V - 20%	314-1014
C402	Cap., .005MFD, +80% 100V - 20%	314-1014
C403	Cap., .005MFD, +80% 100V - 20%	314-1014
C404	Cap. 100PFD, \pm 10%, 1000V	314-1021
C405	Cap., 470PFD, \pm 10%, 1000V	314-1013
C406	Cap., 1000PFD, \pm 20%, Feed-Thru	322-1000
C407	Cap., 100PFD, \pm 10%, 1000V	314-1021
C408	Cap., 1000PFD, \pm 20%, Feed-Thru	322-1000
C409	Cap., 47PFD, \pm 20%, Feed-Thru	322-1001
C410	Cap., .005MFD, +80% 100V - 20%	314-1014
C411	Cap., .005MFD, +80% 100V - 20%	314-1014
C412	Cap., 1000PFD, \pm 20%, Feed-Thru	322-1000
C413	Cap., 100PFD, \pm 10%, 1000V	314-1021
C414	Cap., .005 MFD, +80% 100V - 20%	314-1014

Reference Designation	Description and/or Remarks	Marantz Part Number
C415	Cap., 470PFD, $\pm 10\%$, 1000V	314-1013
C416	Cap., 1000PFD, $\pm 20\%$, Feed-Thru	322-1000
C417	Cap., 100PFD, $\pm 10\%$, 1000V	314-1021
C418	Cap., 2.2MFD, $\pm 20\%$, 15V	316-1001
C419	Cap., 2.2 MFD, $\pm 20\%$, 15V	316-1001
C420	Cap., 47PFD, $\pm 20\%$, Feed-Thru	322-1001
C421	Cap., .005MFD, $\begin{matrix} +80\% \\ -20\% \end{matrix}$, 100V	314-1014
C422	Cap., .005MFD, $\begin{matrix} +80\% \\ -20\% \end{matrix}$, 100V	314-1014
C423	Cap., 1000PFD, $\pm 20\%$, Feed-Thru	322-1000
C424	Cap., 100PFD, $\pm 10\%$, 1000V	314-1021
C425	Cap., .005MFD, $\begin{matrix} +80\% \\ -20\% \end{matrix}$, 100V	314-1014
C426	Cap., 1000PFD, $\pm 20\%$, Feed-Thru	322-1000
C427	Cap., 470PFD, $\pm 10\%$, 1000V	314-1013
C428	Cap., 100PFD, $\pm 10\%$, 1000V	314-1021
C429	Cap., 47PFD, $\pm 20\%$, Feed-Thru	322-1001
C430	Cap., .005MFD, $\begin{matrix} +80\% \\ -20\% \end{matrix}$, 100V	314-1014
C431	Cap., .005MFD, $\begin{matrix} +80\% \\ -20\% \end{matrix}$, 100V	314-1014
C432	Cap., 1000PFD, $\pm 20\%$, Feed-Thru	322-1000
C433	Cap., .005MFD, $\begin{matrix} +80\% \\ -20\% \end{matrix}$, 100V	314-1014
C434	Cap., 470PFD, $\pm 10\%$, 1000V	314-1013
C435	Cap., 1000 PFD, $\pm 20\%$, Feed-Thru	322-1000

Reference Designation	Description and/or Remarks	Marantz Part Number
C436	Cap., 47PFD, $\pm 20\%$, Feed-Thru	322-1001
C437	Cap., 1000PFD, $\pm 20\%$, Feed-Thru	322-1000
C438	Cap., 1000PFD, $\pm 20\%$, Feed-Thru	322-1000
C439	Cap., 1000PFD, $\pm 20\%$, Feed-Thru	322-1000
C440	Cap., 47PFD, $\pm 20\%$, Feed-Thru	322-1001
CR401	Diode, Signal	335-1017
CR402	Diode, Signal	335-1017
CR403	Diode, Hot Carrier	335-1039
CR404	Diode, Hot Carrier	335-1039
CR405	Diode, Signal	335-1017
CR406	Diode, Signal	335-1017
CR407	Diode, Hot Carrier	335-1039
CR408	Diode, Hot Carrier	335-1039
CR409	Diode, Signal	335-1017
CR410	Diode, Signal	335-1017
CR411	Diode, Hot Carrier	335-1039
CR412	Diode, Hot Carrier	335-1039
CR413	Diode, Limiting	335-1033
CR414	Diode, Limiting	335-1033
L401	Choke, 55 μ H	255-1009
L402	Choke, 4.7 μ H	255-1019
L403	Choke, 55 μ H	255-1009
L404	Choke, 55 μ H	255-1009
L405	Choke, 55 μ H	255-1009
L406	Choke, 55 μ H	255-1009
L407	Choke, 55 μ H	255-1009
L408	Choke, 4.7 μ H	255-1019
L409	Choke, 55 μ H	255-1009
L410	Choke, 55 μ H	255-1009
L411	Choke, 55 μ H	255-1009
L412	Choke, 55 μ H	255-1009
L413	Choke, 55 μ H	255-1009
L414	Choke, 55 μ H	255-1009
L415	Choke, 4.7 μ H	255-1019
L416	Choke, 55 μ H	255-1009

Reference Designation	Description and/or Remarks	Marantz Part Number
L417	Choke, 55 μ H	255-1009
L418	Choke, 55 μ H	255-1009
L419	Choke, 55 μ H	255-1009
L420	Choke, 55 μ H	255-1009
L421	Choke, 4.7 μ H	255-1019
L422	Choke, 55 μ H	255-1009
L423	Choke, 55 μ H	255-1009
Q401	Transistor, NPN	334-1018
Q402	Transistor, NPN	334-1018
Q403	Transistor, NPN	334-1018
Q404	Transistor, NPN	334-1018
R401	Res., 2.7K, \pm 10%, 1/4W	326-1174
R402	Res., 220ohm, \pm 10%, 1/4W	326-1162
R403	Res., 47K, \pm 10%, 1/4W	326-1176
R404	Res., 2.7K, \pm 10%, 1/4W	326-1174
R405	Res., 220ohm, \pm 10%, 1/4W	326-1162
R406	Res., 47K, \pm 10%, 1/4W	325-1176
R407	Res., 2.7K, \pm 10%, 1/4W	326-1174
R408	Res., 220ohm, \pm 10%, 1/4W	326-1162
R409	Res., 47K, \pm 10%, 1/4W	326-1176
R410	Res., 47K, \pm 10%, 1/4W	326-1176
R411	Res., 2.7K \pm 10%, 1/4W	326-1174
R412	Res., 100ohm, \pm 10%, 1/4W	325-1173
R413	Control, Trimmer, 25K (AM Display - White)	333-1006
R414	Control, Trimmer, 10K (D.C. Level - Blue)	333-1051
R415	Res., 47K, \pm 10%, 1/4W	326-1176
R416 \triangle	Res., 120K, \pm 10%, 1/4W	326-1153
R417	Control, Trimmer, 150K (Muting - Blue)	333-1052
R418	Res., 220K, \pm 10%, 1/4W	326-1179
	Input Cable Assembly	292-1036
	Output Cable Assembly	292-1037
	Cover	295-1035

Reference Designation	Description and/or Remarks	Marantz Part Number
	Shield	295-1042
	P.C. Board Component Assy. Complete	311-1104-1
	P.C. Board Only	265-1002

\triangle R416 may be 220K \pm 10%, 1/4W, P/N 326-1179 up to S/N 1386.

Reference Designation	Description and/or Remarks	Marantz Part Number
A5	MPX Oscillator Board Component Ass'y complete	311-1052-1
C501	Cap., 2200PFD, \pm 1%, 500V	317-1017
C502	Cap., 100PFD, \pm 5%, 1000V	314-1006
C503	Cap., 150PFD, \pm 5%, 1000V	314-1005
C504	Cap., 150PFD, \pm 5%, 1000V	314-1005
C505	Cap., 1800PFD, \pm 1%, 500V	317-1018
C506	Cap., 270PFD, \pm 5%, 1000V	314-1022
C507	Cap., 2200PFD, \pm 1%, 500V	317-1017
C508	Cap., 1000PFD, \pm 2 1/2%, 160V	315-1005
C509	Cap., 1000PFD, \pm 2 1/2%, 160V	315-1005
C510	Cap., 510PFD, \pm 2 1/2%, 500V	317-1002
C512	Cap., .047MFD, \pm 5%, 250V	313-1004
C513	Cap., 100PFD, \pm 5%, 1000V	314-1006
C514	Cap., 33PFD, \pm 5%, 1000V	314-1009
C515	Cap., .047MFD, \pm 5%, 250V	313-1004
C516	Cap., 22MFD, \pm 10%, 250V	313-1001
C517	Cap., 2200PFD, \pm 1%, 500V	317-1017

Reference Designation	Description and/or Remarks	Marantz Part Number
C518	Cap., 150PFD, $\pm 5\%$, 1000V	314-1005
C519	Cap., .01MFD, $\pm 20\%$, 500V	314-1003
C520	Cap., .01MFD, $\pm 20\%$, 500V	314-1003
C521	Cap., 0.1MFD, $\pm 20\%$, 12VDC	383-1007
C522	Cap. Elect., 680MFD, 16V	381-1008
CR501	Diode	335-1016
CR502	Diode	335-1016
CR503	Diode, Ref. (Stabistor)	335-1000
CR504	Diode	335-1016
CR505	Diode	335-1016
CR506	Diode	335-1004
L501	38KHz Coil	311-1014
L-502	19KHz Coil	311-1015
L-503	38KHz Doubler Coil	311-1013
L-504	67KHz Coil	311-1016
R501	Res., 18K, $\pm 2\%$, $\frac{1}{4}W$	330-1046
R502	Res., 3.3K, $\pm 2\%$, $\frac{1}{4}W$	330-1047
R503	Res., 22K, $\pm 5\%$, $\frac{1}{4}W$	327-1027
R504	Res., 10K, $\pm 5\%$, $\frac{1}{4}W$	327-1024
R505	Res., 3.3K, $\pm 10\%$, $\frac{1}{4}W$	327-1006
R506	Res., 3.3K, $\pm 2\%$, $\frac{1}{4}W$	330-1047
R507	Res., 12K, $\pm 2\%$, $\frac{1}{4}W$	330-1045
R508	Res., 6.8K, $\pm 5\%$, $\frac{1}{4}W$	327-1003
R509	Res., 4.7K, $\pm 5\%$, $\frac{1}{4}W$	327-1049
R510	Res., 22K, $\pm 5\%$, $\frac{1}{4}W$	327-1027
R511	Potentiometer, 10K (Horz, Gain - Green)	333-1005
R512	Res., 390ohm, $\pm 5\%$, $\frac{1}{4}W$	327-1052
R513	Res., 1Meg, $\pm 10\%$, $\frac{1}{4}W$	327-1001
R514	Res., 68ohm, $\pm 5\%$, $\frac{1}{4}W$	327-1045
R515	Res., 300ohm, $\pm 5\%$, $\frac{1}{4}W$	327-1054
R516	Res., 4.7K, $\pm 5\%$, $\frac{1}{4}W$	327-1049
R517	Res., 2.2K, $\pm 5\%$, $\frac{1}{4}W$	327-1051
R518	Potentiometer, W/W, 2.5K (Separation)	333-1010

Reference Designation	Description and/or Remarks	Marantz Part Number
R519	Res., 56K, $\pm 10\%$, 1W	326-1172
R521	Res., 4.3K, $\pm 5\%$, $\frac{1}{4}W$	327-1050
R522	Res., 47K, $\pm 5\%$, $\frac{1}{4}W$	327-1022
R523	Res., 4.7K, $\pm 5\%$, $\frac{1}{4}W$	327-1049
R525	Res., 4.7K, $\pm 5\%$, $\frac{1}{4}W$	327-1049
R526	Res., 1K, $\pm 5\%$, $\frac{1}{4}W$	327-1036
R527	Res., 3.9K, $\pm 10\%$, $\frac{1}{4}W$	327-1047
R528	Potentiometer, 25K - (Stereo threshold - White)	333-1006
R529	Res., 3.3K, $\pm 10\%$, $\frac{1}{4}W$	327-1006
R530	Res., 22K, $\pm 5\%$, $\frac{1}{4}W$	327-1027
R531	Res., 1K, $\pm 5\%$, $\frac{1}{4}W$	327-1036
R532	Res., 3.3K, $\pm 10\%$, $\frac{1}{4}W$	327-1006
Q501	Transistor, PNP	334-1008
Q502	Transistor, NPN	334-1009
Q503	Transistor, NPN	334-1009
Q504	Transistor, NPN	334-1010
Q505	Transistor, NPN	334-1034
Q506	Transistor, NPN	334-1009
Q507	Transistor, NPN	334-1009
Q508	Transistor, FET P-Channel	334-1012
Q509	Transistor, NPN	334-1009
Q510	Transistor, NPN	334-1010
Q511	Transistor, NPN	334-1010
T-501	38KHz Oscillator Transformer	311-1012
	P.C. Board only	265-1008
	Mounting Brackets	295-1212
	P.C. Board Insulator	290-1108
Z501	Photocell Muting Dble Pole	331-1006

Reference Designation	Description and/or Remarks	Marantz Part Number
A6	Multiplex Matrix Board Component Assy Complete	311-1042-1
C601	Cap., 100PFD, $\pm 5\%$, 1000V	314-1007
C602	Cap., 1000PFD, $\pm 2\frac{1}{2}\%$, 160V	315-1005
C603	Cap., 0.1MFD, $\pm 10\%$, 100V	313-1022
C604	Cap., 1000PFD, $\pm 2\frac{1}{2}\%$, 160V	315-1005
C605	Cap., 100PFD, $\pm 5\%$, 1000V	314-1007
C606	Cap., 1100PFD, $\pm 2\frac{1}{2}\%$, 160V	315-1004
C607	Cap., 1100PFD, $\pm 2\frac{1}{2}\%$, 160V	315-1004
C608	Cap., 1000PFD, $\pm 2\frac{1}{2}\%$, 160V	315-1005
C609	Cap., 100PFD, $\pm 5\%$, 1000V	314-1007
C610	Cap., 820PFD, $\pm 2\frac{1}{2}\%$, 160V	315-1006
C611	Cap., 820PFD, $\pm 2\frac{1}{2}\%$, 160V	315-1006
C612	Cap., 1100PFD, $\pm 2\frac{1}{2}\%$, 160V	315-1004
C613	Cap., 1100PFD, $\pm 2\frac{1}{2}\%$, 160V	315-1004
C614	Cap., 150PFD, $\pm 5\%$, 1000V	314-1005
C615	Cap., 100PFD, $\pm 5\%$, 1000V	314-1007
C616	Cap., 1000PFD, $\pm 2\frac{1}{2}\%$, 160V	315-1005
C617	Cap., 0.1MFD, $\pm 10\%$, 100V	313-1022
C618	Cap., 3600PFD, $\pm 2\frac{1}{2}\%$, 160V	315-1002
C619	Cap., 360PFD, $\pm 2\frac{1}{2}\%$, 160V	315-1002
C620	Cap., 0.1MFD, $\pm 10\%$, 100V	313-1022

Reference Designation	Description and/or Remarks	Marantz Part Number
C621	Cap., .033MFD, $\pm 10\%$, 250V	313-1005
C622	Cap., .033MFD, $\pm 10\%$, 250V	313-1005
C623	Cap., 300PFD, $\pm 2\frac{1}{2}\%$, 160V	315-1008
C624	Cap., 300PFD, $\pm 2\frac{1}{2}\%$, 160V	315-1008
C625	Cap., 1100PFD, $\pm 2\frac{1}{2}\%$, 160V	315-1004
C626	Cap., 1100PFD, $\pm 2\frac{1}{2}\%$, 160V	315-1004
C627	Cap., 0.22MFD, $\pm 10\%$, 250V	313-1001
C628	Cap., 0.22MFD, $\pm 10\%$, 250V	313-1001
C629	Cap., 0.22MFD, $\pm 10\%$, 250V	313-1001
C630	Cap., .03MFD, $\pm 20\%$, 100V	383-1002
CR601	Diode, Silicon, Signal	335-1016
CR602	Diode, Silicon, Signal	335-1016
CR603	Diode, Silicon, Signal	335-1016
CR604	Diode, Silicon, Signal	335-1016
L601	LPF Coil Sub Assembly -53mH $\pm 1\text{MH}$	311-1017
L602	LPF Coil Sub Assembly -53mH $\pm 1\text{MH}$	311-1017
L603	LPF Coil Sub Assembly -53mH $\pm 1\text{MH}$	311-1017
L604	LPF Coil Sub Assembly -53mH $\pm 1\text{MH}$	311-1017
Q601 \triangle	Transistor, FET	334-1012
Q602 \triangle	Transistor, FET	334-1012
Q603	Transistor, FET	334-1012

Reference Designation	Description and/or Remarks	Marantz Part Number
Q604	Transistor, FET	334-1012
Q605	Transistor, NPN	334-1009
Q606	Transistor, NPN	334-1017
R601	Res., 4.7Meg, $\pm 20\%$, $\frac{1}{4}W$	326-1010
R602 \triangle	Res., 3.3K, $\pm 1\%$, $\frac{1}{4}W$	430-4330
R603 \triangle	Res., 3.3K, $\pm 1\%$, $\frac{1}{4}W$	430-4330
R604	Res., 3.9K, $\pm 10\%$, $\frac{1}{4}W$	327-1047
R605	Res., 100K, $\pm 1\%$, $\frac{1}{4}W$	330-1023
R606	Control, W.W., 5K, 2W (Separation)	333-1009
R607	Res., 2.2Meg, $\pm 10\%$, $\frac{1}{4}W$	327-1048
R608	Res., 100K, $\pm 1\%$, $\frac{1}{4}W$	330-1023
R609	Res., 4.7Meg, $\pm 20\%$, $\frac{1}{4}W$	326-1010
R610 \triangle	Res., 4.3K, $\pm 1\%$, $\frac{1}{4}W$	430-4430
R611 \triangle	Res., 4.3K, $\pm 1\%$, $\frac{1}{4}W$	430-4430
R612	Res., 100K, $\pm 1\%$, $\frac{1}{4}W$	330-1023
R613	Res., 2.2Meg, $\pm 10\%$, $\frac{1}{4}W$	327-1048
R614	Res., 100K, $\pm 1\%$, $\frac{1}{4}W$	330-1023
R615 \triangle	Res., 11.3K $\pm 1\%$, $\frac{1}{4}W$	330-1024
R616 \triangle	Res., 11.3K $\pm 1\%$, $\frac{1}{4}W$	330-1024
R617	Res., 39K, $\pm 10\%$, $\frac{1}{4}W$	327-1023
R618	Res., 5.6K, $\pm 5\%$, $\frac{1}{4}W$	327-1044
R619	Res., 5.6K, $\pm 5\%$, $\frac{1}{4}W$	327-1044
R620	Res., 1Meg, $\pm 10\%$, $\frac{1}{4}W$	327-1001

Reference Designation	Description and/or Remarks	Marantz Part Number
R621	Res., 220ohm, $\pm 10\%$, $\frac{1}{4}W$	327-1111
R622	Res., 680K, $\pm 10\%$, $\frac{1}{4}W$	327-1046
R623	Res., 680K, $\pm 10\%$, $\frac{1}{4}W$	327-1046
R624	Res., 180K, $\pm 5\%$, $\frac{1}{4}W$	327-1042
R625	Res., 390K, $\pm 5\%$, $\frac{1}{4}W$	327-1040
R626	Res., 270K, $\pm 5\%$, $\frac{1}{4}W$	327-1041
R627	Res., 22K, $\pm 5\%$, $\frac{1}{4}W$	327-1027
R628	Res., 3.9K, $\pm 10\%$, $\frac{1}{4}W$	327-1047
R629	Res., 3.9K, $\pm 10\%$, $\frac{1}{4}W$	327-1047
R630	Res., 33K, $\pm 10\%$, 2W	326-1009
R631	Res., 82ohm, $\pm 5\%$, $\frac{1}{4}W$	327-1058
R632	Res., 68K, $\pm 10\%$, $\frac{1}{4}W$	327-1011
Z601	Data Cell (Dual)	331-1005
Z602	Data Cell (Dual)	331-1005
	P.C. Board Only	265-1009
	Mounting Brackets	295-1212
	P.C. Board Insulator	290-1108

\triangle R602 and R603 were 3.6K, $\pm 1\%$, $\frac{1}{4}W$, P/N 330-1026 prior to S/N 1101.

\triangle R610 and R611 were 5.1K, $\pm 1\%$, $\frac{1}{4}W$, P/N 330-1025 prior to S/N 1101.

\triangle R615 and R616 will be 5.3K (5.23K) P/N 430-4530 in 220 volt units (50 μ second demphasis)

\triangle Q601 and Q602 have a selected Y_{fs} (GM) and f_{dss} Range and should be replaced as a pair.

Reference Designation	Description and/or Remarks	Marantz Part Number
A7	Detector Assy Complete	311-1087-1
C701	Cap., 1000PFD, $\pm 20\%$, Feed-Thru	322-1000
C702	Cap., .005MFD, $+80\%$, 100V -20%	314-1014
C703	Cap., .005MFD, $+80\%$, 100V -20%	314-1014
C704	Cap., 2.2MFD, $+80\%$, 15V -20%	316-1001
C705	Cap., .005MFD, $+80\%$, 100V -20%	314-1014
C706	Cap., 1 - 18PFD Trimmer, Air, P.C. Mt.	321-1000
C707	Cap., 70PFD, $\pm 1\%$, 500V	317-1004
C708	Cap., 5.6PFD, $\pm 5\%$ 500V	317-1003
C709	Cap., .005MFD, $+80\%$, 100V -20%	314-1014
C710	Cap., 155PFD, $\pm 2\%$ 500V	317-1005
C711	Cap., .005MFD, $+80\%$, 100V -20%	314-1014
C712	Cap., 1 - 18PFD Trimmer, Air P.C. Mt.	321-1000
C713	Cap., 2.2MFD, $\pm 20\%$, 15V	316-1001
C714	Cap., 22PFD, $\pm 10\%$, 1000V	314-1015
C715	Cap., .005MFD, $+80\%$, 100V -20%	314-1014
C716	Cap., 1.000PFD, $\pm 20\%$, Feed-thru	322-1000
CR701	Diode	335-1017
CR702	Diode	335-1017
J701	Phono Jack	269-1004

Reference Designation	Description and/or Remarks	Marantz Part Number
L701	Choke, 55 μ H	255-1009
L702	Choke, 55 μ H	255-1009
L703	Coil, Discriminator	255-1001
L704	Choke, 55 μ H	255-1009
L705	Choke, 55 μ H	255-1009
L706	Choke, 55 μ H	255-1009
Q701	Transistor, NPN	334-1032
R701	Res., 2.2K, $\pm 5\%$, $\frac{1}{4}$ W	326-1104
R702	Res., 8.2K, $\pm 5\%$, $\frac{1}{4}$ W	326-1028
R703 \triangle	Res. 390ohm, $\pm 5\%$, $\frac{1}{2}$ W	433-3392
R704	Res., 5.6K, $\pm 5\%$, $\frac{1}{4}$ W	326-1036
R705	Res., 100K, $\pm 1\%$, $\frac{1}{4}$ W	330-1023
R706	Res., 100K, $\pm 1\%$, $\frac{1}{4}$ W	330-1023
	P.C. Board Compo- nent Assy Complete	311-1103-1
	P.C. Board Only	265-1003
	Transistor Heat Dissipater	562-1000
	Cover	295-1037
	Output Cable Assy	292-1035

\triangle R703 was 560 ohms, $\pm 5\%$, $\frac{1}{2}$ W, P/N 326-1098 prior to S/N 1501.

Reference Designation	Description and/or Remarks	Marantz Part Number
A8	Phono Board Component Assy Complete	311-1045-1
C801	Cap., 56PFD, $\pm 5\%$, 500V	317-1001
C802	Cap., 0.47MFD, $\pm 10\%$, 250V	313-1035
C803	Cap., 0.47MFD, $\pm 10\%$, 250V	313-1035
C804	Cap., 56PFD, $\pm 5\%$, 500V	317-1001
C805	Cap., 33PFD, $\pm 5\%$, 500V	317-1000
C806	Cap., 33PFD, $\pm 5\%$, 500V	317-1000
C807	Cap., 22MFD, $\pm 20\%$, 4V	316-1000
C808	Cap., 22MFD, $\pm 20\%$, 4V	316-1000
C809	Cap., 5600PFD, $\pm 2\frac{1}{2}\%$, 160V	315-1001
C810	Cap., 5600PFD, $\pm 2\frac{1}{2}\%$, 160V	315-1001
C811	Cap., 3.9PFD, $\pm 10\%$	314-1011
C812	Cap., 3.9PFD, $\pm 10\%$	314-1011
C813	Cap., 1650PFD, $\pm 2\frac{1}{2}\%$, 160V	315-1003
C814	Cap., 1650PFD, $\pm 2\frac{1}{2}\%$, 160V	315-1003
C815	Cap., 0.47MFD $\pm 10\%$, 250V	313-1000
C816	Cap., 0.47MFD, $\pm 10\%$, 250V	313-1000
CR801	Diode, Ref. Stabistor	335-1001
CR802	Diode, Ref. Single Silicon	335-1014
CR803	Diode, Ref. Single Silicon	335-1014
Q801	Transistor, PNP	334-1043
Q802	Transistor, PNP	334-1043
Q803	Transistor, PNP	334-1008
Q804	Transistor, PNP	334-1008

Reference Designation	Description and/or Remarks	Marantz Part Number
Q805	Transistor, PNP	334-1008
Q806	Transistor, PNP	334-1008
R801	Res., 470ohm, $\pm 5\%$, $\frac{1}{4}W$	327-1026
R802	Res., 470ohm, $\pm 5\%$, $\frac{1}{4}W$	327-1026
R803	Res., 470ohm, $\pm 5\%$, $\frac{1}{4}W$	327-1026
R804	Res., 470ohm, $\pm 5\%$, $\frac{1}{4}W$	327-1026
R805	Trimmer, Control 100K (Blue - D.C. Balance)	333-1007
R806	Trimmer, Control 100K (Blue - D.C. Balance)	333-1007
R807	Res., 1Meg, $\pm 5\%$, $\frac{1}{4}W$ - C/F	327-1030
R808	Res., 1Meg, $\pm 5\%$, $\frac{1}{4}W$ - C/F	327-1030
R809	Res., 18K, $\pm 5\%$, $\frac{1}{4}W$ - C/F	327-1060
R810	Res., 18K, $\pm 5\%$, $\frac{1}{4}W$ - C/F	327-1060
R811	Pot., Volume, Straight Tandem, 250K	333-1040
R812	Res., 33K, $\pm 5\%$, $\frac{1}{4}W$	327-1043
R813	Res., 470ohm, $\pm 1\%$, $\frac{1}{4}W$ - C/F	330-1017
R814	Res., 470ohm, $\pm 1\%$, $\frac{1}{4}W$ - C/F	330-1017
R815	Res., 2.2Meg, $\pm 5\%$, $\frac{1}{4}W$ - C/F	327-1029
R816	Res., 2.2Meg, $\pm 5\%$, $\frac{1}{4}W$ - C/F	327-1029
R817	Res., 2.2Meg, $\pm 5\%$, $\frac{1}{4}W$ - C/F	327-1029
R818	Res., 270K, $\pm 5\%$, $\frac{1}{4}W$	327-1041
R819	Res., 270K, $\pm 5\%$, $\frac{1}{4}W$	327-1041

Reference Designation	Description and/or Remarks	Marantz Part Number
R820	Res., 2.2Meg, $\pm 5\%$, $\frac{1}{4}W$ - C/F	327-1029
R821	Pot., Balance, Straight Tandem, 500K	333-1041
R822	Res., 47ohm, $\pm 5\%$, $\frac{1}{4}W$	327-1059
R823	Res., 47ohm, $\pm 5\%$, $\frac{1}{4}W$	327-1059
R824	Res., 100K, $\pm 5\%$, $\frac{1}{4}W$	327-1021
R825	Res., 100K, $\pm 5\%$, $\frac{1}{4}W$	327-1021
R826	Res., 680K, $\pm 2\%$, $\frac{1}{4}W$ - C/F	330-1002
R827	Res., 680K, $\pm 2\%$, $\frac{1}{4}W$ - C/F	330-1002
R828	Res., 47K, $\pm 5\%$, $\frac{1}{4}W$	327-1022
R829	Res., 47K, $\pm 5\%$, $\frac{1}{4}W$	327-1022
R830	Res., 2.2K, $\pm 5\%$, $\frac{1}{4}W$	327-1051
R831	Res., 2.2K, $\pm 5\%$, $\frac{1}{4}W$	327-1051
R832	Res., 47K, $\pm 1\%$, $\frac{1}{4}W$ - C/F	330-1016
R833	Res., 47K, $\pm 1\%$, $\frac{1}{4}W$ - C/F	330-1016
R834	Res., 4.7K, $\pm 5\%$, $\frac{1}{4}W$	326-1002
R835	Res., 4.7K, $\pm 5\%$, $\frac{1}{4}W$	326-1002
	Transistor Socket - Elco P/N 05-3304	368-1002
	P.C. Board Only	265-1006
	Insulator (Under Board)	127-1004

 Sockets not used prior to S/N 1501.

Reference Designation	Description and/or Remarks	Marantz Part Number
A9	Scope Board Compo- nent Assy Complete	311-1107-1
C901	Cap., .01MFD, $+80\%$ -20% , 1K, V	314-1002
C902	Cap., .01MFD, $+80\%$ -20% , 1K, V	314-1002
C903	Cap., .022MFD, $\pm 20\%$, 600V	313-1025
CR901	Diode, Rect. 200 PIV 1A	335-1004
CR902	Diode, Rect. 200 PIV 1A	335-1004
CR903	Diode, Ref. (Stabistor)	335-1014
Q901	Transistor, FET	334-1030
Q902	Transistor, High Voltage, NPN	334-1034
Q903	Transistor, High Voltage, NPN	334-1034
Q904	Transistor, FET	334-1030
Q905	Tranistor, High Voltage, NPN	334-1034
Q906	Transistor, High Voltage, NPN	334-1034
R901	Res., 1K, $\pm 5\%$, $\frac{1}{4}W$	327-1036
R902	Res., 270K, $\pm 5\%$, $\frac{1}{4}W$	327-1041
R903	Res., 3.3K, $\pm 5\%$, $\frac{1}{4}W$	327-1025
R904	Res., 4.7K, $\pm 5\%$, $\frac{1}{4}W$	327-1049
R905	Res., 4.7K, $\pm 5\%$, $\frac{1}{4}W$	327-1049
R906	Res., 2.4K, $\pm 5\%$, $\frac{1}{4}W$	327-1118
R907	Res., 6.8K, $\pm 10\%$, $\frac{1}{2}W$	326-1063
R908	Res., 100K, $\pm 10\%$, $\frac{1}{2}W$	326-1013
R909	Res., 5.6K, $\pm 5\%$, $\frac{1}{2}W$	326-1093

Reference Designation	Description and/or Remarks	Marantz Part Number
R910	Res., 5.6K, $\pm 5\%$, $\frac{1}{2}W$	326-1093
R911	Res., 100K, $\pm 10\%$, $\frac{1}{2}W$	326-1013
R912	Res., 680ohm, $\pm 10\%$, $\frac{1}{4}W$	327-1017
R913	Res., 1Meg, $\pm 10\%$, $\frac{1}{4}W$	327-1001
R914	Res., 47K, $\pm 5\%$, $\frac{1}{4}W$	327-1022
R915	Control, Trimmer, 150K (Red-Focus)	333-1008
R916	Res., 390K, $\pm 10\%$, 1W	326-1012
R917	Res., 100K, $\pm 10\%$, $\frac{1}{2}W$	326-1013
R918	Res., 1.5Meg, $\pm 10\%$, $\frac{1}{4}W$	327-1056
R919	Res., 1Meg, $\pm 10\%$, $\frac{1}{4}W$	327-1001
R920	Res., 100K, $\pm 10\%$, $\frac{1}{2}W$	326-1013
R921	Control, Trimmer, 25K (White - Intensity)	333-1006
R922	Res., 4.7K, $\pm 5\%$, $\frac{1}{4}W$	327-1049
R923	Res., 680ohm, $\pm 10\%$, $\frac{1}{4}W$	327-1017
R924	Res., 100K, $\pm 10\%$, $\frac{1}{2}W$	326-1013
R925	Res., 5.6K, $\pm 5\%$, $\frac{1}{2}W$	326-1093
R926	Res., 5.6K, $\pm 5\%$, $\frac{1}{2}W$	326-1093
R927	Res., 6.8K, $\pm 10\%$, $\frac{1}{2}W$	326-1063
R928	Res., 2.4K, $\pm 5\%$, $\frac{1}{4}W$	327-1118
R929	Res., 4.7K, $\pm 5\%$, $\frac{1}{4}W$	327-1049
R930	Res., 4.7K, $\pm 5\%$, $\frac{1}{4}W$	327-1049
R931	Res., 3.3K, $\pm 5\%$, $\frac{1}{4}W$	327-1025
R932	Res., 270K, $\pm 5\%$, $\frac{1}{4}W$	327-1041
R933	Res., 1K, $\pm 5\%$, $\frac{1}{4}W$	327-1036
	Socket, Transistor (Small)	268-1023
	Socket, Transistor (Large)	268-1024
	FET Transistor Shield	271-1024
	FET Transistor Shield Sleeving - $\frac{3}{4}$ " Long	820-9012
	P.C. Board only	265-1043
	Terminal cover (Cardboard-Black)	290-1095
	C.R.T. Socket Subassembly	292-1047
	Spacers - P.C. Board to chassis	279-1033

Reference Designation	Description and/or Remarks	Marantz Part Number
A10	Tone Board Component Assembly complete	311-1047-1
C1001	Cap., 0.22MFD, $\pm 10\%$, 250V	313-1001
C1002	Cap., Elect., 100MFD, 6.4V	319-1028
C1003	Cap., 220PFD, $\pm 2\frac{1}{2}\%$, 160V	315-1009
C1004	Cap., Elect., 100MFD, 6.4V	319-1028
C1005	Cap., 6800PFD, $\pm 2\frac{1}{2}\%$, 160V	315-1000
C1006	Cap., 6800PFD, $\pm 2\frac{1}{2}\%$, 160V	135-1000
C1007	Cap., 0.22MFD, $\pm 10\%$, 250V	313-1001
C1008	Cap., 0.47MFD, $\pm 10\%$, 250V	313-1000
C1009	Cap., 0.47MFD, $\pm 10\%$, 250V	313-1000
C1010	Cap., 0.47MFD, $\pm 10\%$, 250V	313-1000
C1011	Cap., 0.47MFD, $\pm 10\%$, 250V	313-1000
C1012	Cap., 0.47MFD, $\pm 10\%$, 250V	313-1000
C1013	Cap., 0.47MFD, $\pm 10\%$, 250V	313-1000
C1014	Cap., 0.22MFD, $\pm 10\%$, 250V	313-1001
C1015	Cap., 6800PFD, $\pm 2\frac{1}{2}\%$, 160V	315-1000
C1016	Cap., 6800PFD, $\pm 2\frac{1}{2}\%$, 160V	315-1000
C1017	Cap., Elect., 100MFD, 6.4V	319-1028
C1018	Cap., 220PFD, $\pm 2\frac{1}{2}\%$, 160V	315-1009
C1019	Cap., Elect., 100MFD, 6.4V	319-1028
C1020	Cap., 0.22MFD, $\pm 10\%$, 250V	313-1001

Reference Designation	Description and/or Remarks	Marantz Part Number
C1021 \triangle	Cap., 470PFD, $\pm 10\%$, 1000V	314-1013
C1022 \triangle	Cap., 150PFD, $\pm 10\%$, 100V	385-1038
C1023 \triangle	Cap., 150PFD, $\pm 10\%$, 100V	385-1038
C1024 \triangle	Cap., 470PFD, $\pm 10\%$, 1000V	314-1013
Q1001 \triangle	Transistor, PNP	334-1007
Q1002	Transistor, NPN	334-1010
Q1003	Transistor, PNP	334-1008
Q1004	Transistor, NPN	334-1031
Q1005	Transistor, NPN	334-1031
Q1006	Transistor, PNP	334-1008
Q1007	Transistor, NPN	334-1010
Q1008 \triangle	Transistor, PNP	334-1007
R1001 \triangle	Res., 9.1K, $\pm 5\%$, $\frac{1}{4}W$	434-4912
R1002	Pot. Dual, Tandem, 250K (Treble)	333-1043
R1003	Res., 22K, $\pm 5\%$, $\frac{1}{4}W$	327-1027
R1004 \triangle	Res., 9.1K, $\pm 5\%$, $\frac{1}{4}W$	434-4912
R1005	Res., 68K, $\pm 5\%$, $\frac{1}{4}W$	434-5682
R1006	Res., 47K, $\pm 5\%$, $\frac{1}{4}W$	321-1022
R1007	Res., 220ohm, $\pm 5\%$, $\frac{1}{4}W$	327-1055
R1008	Res., 120K, $\pm 5\%$, $\frac{1}{4}W$	327-1061
R1009	Res., 750ohm, $\pm 1\%$, $\frac{1}{4}W$	430-3750
R1010	Res., 1MEG, $\pm 5\%$, $\frac{1}{4}W$	327-1030
R1011	Res., 20K, $\pm 1\%$, $\frac{1}{4}W$	330-1028
R1012	Res., 10K, $\pm 5\%$, $\frac{1}{4}W$	327-1024
R1013	Res., 39K, $\pm 1\%$, $\frac{1}{4}W$	330-1027
R1014	Pot. Dual, Tandem, 500K (Bass)	333-1042
R1015	Res., 39K, $\pm 1\%$, $\frac{1}{4}W$	330-1027
R1016	Res., 22K, $\pm 5\%$, $\frac{1}{4}W$	327-1033
R1017	Res., 10K, $\pm 5\%$, $\frac{1}{4}W$	327-1024
R1018	Res., 10K, $\pm 5\%$, $\frac{1}{4}W$	327-1024
R1019	Res., 22K, $\pm 5\%$, $\frac{1}{4}W$	327-1033
R1020	Res., 39K, $\pm 1\%$, $\frac{1}{4}W$	330-1027

Reference Designation	Description and/or Remarks	Marantz Part Number
R1022	Res., 39K, $\pm 1\%$, $\frac{1}{4}W$	330-1027
R1023	Res., 10K, $\pm 5\%$, $\frac{1}{4}W$	327-1024
R1024	Res., 20K, $\pm 1\%$, $\frac{1}{4}W$	330-1028
R1025	Res., 1MEG, $\pm 5\%$, $\frac{1}{4}W$	327-1030
R1026	Res., 750ohm, $\pm 1\%$, $\frac{1}{4}W$	430-3750
R1027	Res., 120K, $\pm 5\%$, $\frac{1}{4}W$	327-1061
R1028	Res., 220ohm, $\pm 5\%$, $\frac{1}{4}W$	327-1055
R1029	Res., 47K, $\pm 5\%$, $\frac{1}{4}W$	327-1022
R1030	Res., 68K, $\pm 5\%$, $\frac{1}{4}W$	434-5682
R1031 \triangle	Res., 9.1K, $\pm 5\%$, $\frac{1}{4}W$	434-4912
R1032	Res., 22K, $\pm 5\%$, $\frac{1}{4}W$	327-1027
R1034 \triangle	Res., 9.1K, $\pm 5\%$, $\frac{1}{4}W$ P.C. Board Only	434-4912 265-1005

\triangle C1021, C1022, C-1023 and C1024 not used prior to S/N 1501.

\triangle Q1001 and Q1008 were P/N 334-1008 prior to S/N 1501.

\triangle R1001 and R1034 were 15K, $\pm 5\%$, $\frac{1}{4}W$, P/N 327-1062 prior to S/N 1501.

\triangle R1004 and R1031 were 10K, $\pm 5\%$, $\frac{1}{4}W$, P/N 327-prior to S/N 1501.

Reference Designation	Description and/or Remarks	Marantz Part Number
A11 \triangle	Hi-Low Filter Board Component Assembly Complete	311-1117-1
C1101	Cap., .022MFD, $\pm 5\%$, 250V	313-1008
C1102	Cap., .047MFD, $\pm 5\%$, 250V	313-1004
C1103	Cap., .047MFD, $\pm 5\%$, 250V	313-1004
C1104	Cap., 470PFD, $\pm 2\frac{1}{2}\%$, 160V	315-1010
C1105	Cap., .047MFD, $\pm 5\%$, 250V	313-1004
C1106	Cap., .022MFD, $\pm 5\%$, 250V	313-1008
C1107	Cap., .047MFD, $\pm 5\%$, 250V	313-1004

Reference Designation	Description and/or Remarks	Marantz Part Number
C1108	Cap., 470PFD, $\pm 2\frac{1}{2}\%$, 160V	315-1010
C1109	Cap., .0047MFD, $\pm 20\%$, 500V	314-1012
C1110 \triangle	Cap., 1MFD, $\pm 10\%$, 100V	386-1018
C1111 \triangle	Cap., 1MFD, $\pm 10\%$, 100V	386-1018
Q1101 \triangle	Transistor, PNP	334-1008
Q1102 \triangle	Transistor, PNP	334-1008
R1101	Res., 1Meg, $\pm 10\%$, $\frac{1}{4}W$	327-1001
R1102	Res., 4.7K, $\pm 1\%$, $\frac{1}{4}W$	330-1032
R1103	Res., 22K, $\pm 1\%$, $\frac{1}{4}W$	330-1030
R1104	Res., 10K, $\pm 1\%$, $\frac{1}{4}W$	330-1019
R1105	Res., 22Meg, $\pm 20\%$, $\frac{1}{4}W$	326-1004
R1106	Res., 4.7K, $\pm 1\%$, $\frac{1}{4}W$	330-1032
R1107	Res., 1Meg, $\pm 10\%$, $\frac{1}{4}W$	327-1001
R1108	Res., 22k, $\pm 1\%$, $\frac{1}{4}W$	330-1030
R1109	Res., 10K, $\pm 1\%$, $\frac{1}{4}W$	330-1019
R1110	Res., 22Meg, $\pm 20\%$, $\frac{1}{4}W$	326-1004
R1111	Res., 100K, $\pm 10\%$, $\frac{1}{4}W$	326-1055
R1112	Res., 100K, $\pm 10\%$, $\frac{1}{4}W$	326-1055
R1113 \triangle	Res., 1Meg, $\pm 5\%$, $\frac{1}{4}W$	434-7102
R1114 \triangle	Res., 100K, $\pm 5\%$, $\frac{1}{4}W$	434-6102
R1115 \triangle	Res., 4.7K, $\pm 5\%$, $\frac{1}{4}W$	434-4472
R1116 \triangle	Res., 4.7K, $\pm 5\%$, $\frac{1}{4}W$	434-4472
R1117 \triangle	Res., 100K, $\pm 5\%$, $\frac{1}{4}W$	434-6102
R1118 \triangle	Res., 1Meg, $\pm 5\%$, $\frac{1}{4}W$	434-7102
R1119 \triangle	Res., 1Meg, $\pm 5\%$, $\frac{1}{4}W$	434-7102
R1120 \triangle	Res., 1Meg, $\pm 5\%$, $\frac{1}{4}W$	434-7102
S1101	Pushbutton Switch Assy.	348-1011
	P.C. Board only (up to S/N 1896)	265-1036
	P.C. Board only (S/N 1896 and up)	265-1052

\triangle Component Assy - complete was P/N 311-1053-1 prior to S/N 1896.

\triangle C1110, C1111, Q1101, Q1102, R1113, R1114, R1115, R1116, R1117, R1118, R1119 and R1120 added at S/N 1896 (P.C. Board Number changed - see above).

Reference Designation	Description and/or Remarks	Marantz Part Number
A12	Driver Board Component Ass'y complete	311-1059-1
C1201	Cap., 0.47MFD, $\pm 10\%$, 250V	386-1010
C1202	Cap., 0.47MFD, $\pm 10\%$, 250V	313-1000
C1203	Cap., .01MFD, $\pm 20\%$, 500V	314-1003
C1204	Cap., .001MFD, $\pm 5\%$, 1000V	314-1010
C1205	Cap. Elect., 100MFD, 40V	319-1027
C1206	Cap., 100PFD, $\pm 5\%$, 1000V	314-1007
C1207	Cap. Elect., 10MFD, 100V	319-1003
C1208	Cap. Elect., 200MFD, 15VNP	319-1010
C1209	Cap., 0.22MFD, $\pm 10\%$, 250V	313-1001
C1211	Cap., .033MFD, $\pm 10\%$, 250V	313-1005
C1213	Cap., 0.1MFD, $\pm 10\%$, 250V	313-1023
C1214	Cap., 0.22MFD, $\pm 10\%$, 250V	313-1001
CR1201	Diode, Reference	335-1014
CR1202	Diode, Reference	335-1000
CR1203	Diode, Reference	460-1004
CR1204	Diode, Dual Silicon Assy	335-1040
CR1205	Diode, Reference	335-1014
CR1206	Diode, Reference	335-1014
K1201	Relay, SPDT, 1A, 6V DC	256-1001
L1201	Inductor Assembly	311-1094
L1202	Ferrite Bead (Rod)	255-1008
L1203	Ferrite Bead (Rod)	255-1008
L1204	Ferrite Bead (Rod)	255-1008
L1205	Ferrite Bead (Rod)	255-1008
Q1201	Transistor, PNP	334-1007
Q1202 \triangle	Transistor, PNP	334-1007
Q1203 \triangle	Transistor, PNP	334-1007

Reference Designation	Description and/or Remarks	Marantz Part Number
Q1204	Transistor, NPN	334-1004
Q1205	Transistor, NPN	334-1004
Q1206	Transistor, PNP	334-1005
Q1207	Transistor, NPN	334-1014
Q1208	Transistor, PNP	334-1044
Q1209	Transistor, NPN	334-1014
R1201	Res., 470ohm, $\pm 5\%$, $\frac{1}{4}W$	327-1026
R1202	Res., 100K, $\pm 5\%$, $\frac{1}{4}W$	327-1021
R1203	Res., 91K, $\pm 5\%$, $\frac{1}{4}W$	327-1037
R1204	Res., 10K, $\pm 1\%$, $\frac{1}{4}W$	330-1019
R1205	Res., 3.9K, $\pm 1\%$, $\frac{1}{4}W$	330-1020
R1206	Res., 220ohm, $\pm 1\%$, $\frac{1}{4}W$	330-1022
R1208	Res., 4.7K, $\pm 5\%$, $\frac{1}{4}W$	327-1049
R1209	Res., 620ohm, $\pm 1\%$, $\frac{1}{4}W$	330-1021
R1210	Res., 100ohm, $\pm 5\%$, $\frac{1}{4}W$	326-1007
R1211	Res., 1K, $\pm 5\%$, $\frac{1}{2}W$	433-4102
R1212	Control, D.C. Balance, 1K	333-1048
R1213	Res., 1K, $\pm 5\%$, $\frac{1}{2}W$	433-4102
R1214	Res., 100ohm, $\pm 5\%$, $\frac{1}{4}W$	326-1007
R1215	Res., 5.6K, $\pm 10\%$, 2W	326-1006
R1216	Res., 22ohm, $\pm 10\%$, $\frac{1}{4}W$	326-1008
R1217	Res., 100ohm, $\pm 5\%$, $\frac{1}{4}W$	326-1007
R1218	Res., 2.2K, $\pm 10\%$, 1W	326-1000
R1219	Res., 22ohm, $\pm 10\%$, $\frac{1}{4}W$	326-1008
R1220	Res., 2.2K, $\pm 5\%$, $\frac{1}{2}W$	326-1243
R1221	Res., 100ohm, $\pm 5\%$, $\frac{1}{4}W$	326-1007
R1222	Res., 2.2K, $\pm 5\%$, $\frac{1}{2}W$	326-1243
R1223	Res., 100ohm, $\pm 5\%$, $\frac{1}{4}W$	326-1007
R1224	Res., 100ohm, $\pm 5\%$, $\frac{1}{4}W$	326-1007
R1225	Res., 22ohm, $\pm 10\%$, $\frac{1}{4}W$	326-1008
R1226	Control, Trimmer, 250ohm (Load Line-Blue)	333-1037
R1227	Res., 2.7K, $\pm 5\%$, $\frac{1}{2}W$	326-1196
R1228	Res., 680ohm, $\pm 10\%$, $\frac{1}{2}W$	326-1197
R1229	Res., 680ohm, $\pm 10\%$, $\frac{1}{2}W$	326-1197
R1230	Res., 2.7K, 5%, $\frac{1}{2}W$	326-1196
R1231	Control, Trimmer, 250ohm (Load Line-Blue)	333-1037

Reference Designation	Description and/or Remarks	Marantz Part Number
R1232	Res., 400ohm, $\pm 5\%$, W/W, 5W	329-1005
R1233	Res., 2.2ohm, $\pm 10\%$, 1W	326-1005
R1234	Res., 10ohm, $\pm 5\%$, 2W	326-1185
R1235	Control, Trimmer, 500ohm (Constant Current-Blue)	333-1059
	P.C. Board only	265-1039
	Transistor Sockets	268-1023
	Mounting Brackets	295-1212
	Spacer - P.C. Board to Heatsink	279-1033

⚠ Q1202 and Q1203 to be Beta matched within $\pm 10\%$ and have a minimum Beta of 100.

Reference Designation	Description and/or Remarks	Marantz Part Number
A13	Power Amplifier Component Ass'y (Less Board)	311-1060-1
	Power Amplifier P.C. Board Ass'y - Complete	311-1095-1
C1301	Cap., 470PFD, $\pm 10\%$, 1000V	314-1013
C1302	Cap., 470PFD, $\pm 10\%$, 1000V	314-1013
CR1301	Diode, Ref. 3 Chip, 1.85V	335-1048
CR1302	Diode, Rect. Silicon, 50PIV, 12A	335-1006
CR1303	Diode, Rect. Silicon, 50PIV, 12A	335-1007
Q1301	Transistor, NPN	334-1014
Q1302	Transistor, PNP	334-1001
Q1303	Transistor, NPN	334-1000
Q1304	Transistor, NPN	334-1035
Q1305	Transistor, PNP	334-1036
R1301	Res., .26ohm, $\pm 5\%$, 5W, W/W	329-1026
R1302	Res., 100ohm, $\pm 10\%$, 1W	326-1001

Reference Designation	Description and/or Remarks	Marantz Part Number
R1303	Res., 1K, $\pm 5\%$, $\frac{1}{4}W$	327-1036
R1304	Control, Bias 2.5K	333-1012
R1305	Res., 1K, $\pm 5\%$, $\frac{1}{4}W$	327-1036
R1306	Res., 100ohm, $\pm 10\%$, 1W	326-1001
R1307	Res., .26ohm, $\pm 5\%$, 5W, W/W	329-1026
R1308	Res., 1K, $\pm 5\%$, $\frac{1}{4}W$	327-1036
	MICA Insulator (TO-3)	290-1002
	MICA Insulator (TO-66)	290-1027
XQ1302 and XQ1303	Socket, Transistor (TO-3)	268-1002
	Socket, Transistor (TO-66)	268-1025
XQ1304 and XQ1305	MICA Insulator (Diodes)	290-1103
	Insulating Bushing for TO-3	168-1003-1
	Insulating Bushing for TO-66	168-1003-3
	Insulating Bushing for Diodes	281-1049
	P.C. Board only	265-1049
	Heat sink	295-1159
	Bracket - Clamp (for Q1301 and CR1301)	295-1211
	Bracket - Heat sink to rear cover	295-1205
	Bracket - Heat sink to front panel	295-1207
	Transistor cover (Perforated)	295-1214

Reference Designation	Description and/or Remarks	Marantz Part Number
A14	Time Delay Board Component Ass'y Complete	311-1061-1
C1401	Cap. Elect., 350MFD, 50VDC	319-1030
C1402	Cap. Elect., 350MFD, 50VDC	319-1030
C1403	Cap. Elect., 350MFD, 50VDC	319-1030
C1404 \triangle	Cap. Elect., 5.6MFD, $\pm 10\%$, 35V	381-1047
C1404 \triangle	Cap. Elect., 6.8MFD, $\pm 10\%$, 35V	381-1048
C1404 \triangle	Cap. Elect., 8.2MFD, $\pm 10\%$, 50V	381-1049
C1404 \triangle	Cap. Elect., 10MFD, $\pm 10\%$, 50V	381-1050
C1404 \triangle	Cap. Elect., 3.9MFD, $\pm 10\%$, 50V	381-1051
C1404 \triangle	Cap. Elect., 4.7MFD, $\pm 10\%$, 50V	381-1052
CR1401	Diode, Zener	335-1010
CR1402	Diode, Stabistor	335-1000
CR1403	Diode, Rectifier	335-1005
CR1404	Diode, Rectifier	335-1005
Q1401	Transistor, NPN	334-1010
R1401	Res., 1.5K, $\pm 10\%$, 2W	326-1016
R1402	Res., 18K, $\pm 5\%$, $\frac{1}{4}W$	327-1109
R1403	Res., 15K, $\pm 5\%$, $\frac{1}{4}W$	327-1108
R1404	Res., 68ohm, $\pm 10\%$, $\frac{1}{2}W$	326-1017
R1405	Res., 68ohm, $\pm 10\%$, $\frac{1}{2}W$	326-1017
R1406	Res., 15K, $\pm 5\%$, $\frac{1}{4}W$	327-1108
R1407	Res., 330ohm, $\pm 5\%$, 1W	326-1186
	P.C. Board only	265-1047
	Spacers - P.C. Board to Chassis	279-1037

\triangle C1404 selected from one of the above values in test. Deleted at S/N 1896.

Reference Designation	Description and/or Remarks	Marantz Part Number
A15	Function Switch Board Component Ass'y complete	311-1054-1
C1501	Cap., .01MFD, $\pm 20\%$, 500V	314-1003
C1502	Cap., 0.22MFD, $\pm 10\%$, 250V	313-1007
R1501 \triangle	Res. Prec., 100K, $\pm 2\%$, $\frac{1}{2}W$	432-6101
R1502 \triangle	Res. Prec., 100K, $\pm 2\%$, $\frac{1}{2}W$	432-6101
R1503 \triangle	Res. Prec., 4.7K, $\pm 5\%$, $\frac{1}{4}W$	327-1049
R1504 \triangle	Res. Prec., 4.7K, $\pm 5\%$, $\frac{1}{4}W$	327-1049
R1505	Res., 270K, $\pm 5\%$, $\frac{1}{4}W$	327-1041
R1506	Res., 270K, $\pm 5\%$, $\frac{1}{4}W$	327-1041
	Push Button Switch Assembly - 2 Switches	348-1014
	Push Button Switch Assembly - 4 Switches	348-1011
	P.C. Board only	265-1038

\triangle R1501 and R1502 were 47K, $\pm 10\%$, $\frac{1}{4}W$, P/N 327-1105 prior to S/N 1501.

\triangle R1503 and R1504 were deleted at S/N 1501.

Reference Designation	Description and/or Remarks	Marantz Part Number
	Main Chassis Parts	
C1	Cap. Elect., 1MFD, 63V	319-1023
C2	Cap. Elect., 1MFD, 63V	319-1023
C3	Cap. Elect., 350MFD at 50 VDC	318-1018
C4	Cap. Elect., 9700MFD at 40 VDC	318-1020
C5	Cap. Elect., 9700MFD at 40 VDC	318-1020
C6	Cap., 33PFD, 500V	317-1000
C7	Cap. .005MFD, 100V $\begin{matrix} +80\% \\ -20\% \end{matrix}$	314-1014
C8	Cap. .01MFD $\begin{matrix} +80\% \\ -20\% \end{matrix}$, 1400V	383-1006

Reference Designation	Description and/or Remarks	Marantz Part Number
C9	Cap. .01MFD $\begin{matrix} +80 \\ -20 \end{matrix}$, 1400V	383-1006
C10	Cap. .047MFD $\pm 5\%$, 250V	313-1034
C11	Cap. .047MFD $\pm 5\%$, 250V	313-1034
DS1	Stereo Indicator Lamp Assembly	311-1093-1
	Lamp only - GE#2187I	340-1011
DS2 thru DS6	GE#55	340-1012
F1 \triangle	2 $\frac{1}{2}$ Amp, Slow blow, 125V	341-1005
J7	Jack, Phone, Dble. Clsd.	269-1002
J14, J15	Jack, Phone, Dble Open ckt.	269-1003
L1 thru L6	Ferrite Bead (Rod)	255-1008
L7	Choke, 55uH	255-1009
R1	Res. 4.7K, $\pm 5\%$, $\frac{1}{4}W$	327-1049
R2	Res. 4.7K, $\pm 5\%$, $\frac{1}{4}W$	327-1049
R3	Res. 62ohm, $\pm 5\%$, $\frac{1}{4}W$	326-1187
R4	Res. 15ohm, $\pm 5\%$, $\frac{1}{4}W$	326-1188
R5	Res. 62ohm, $\pm 5\%$, $\frac{1}{4}W$	326-1187
R6	Res. 2.2K, $\pm 10\%$, $\frac{1}{4}W$	327-1015
R7	Res. 2.2K, $\pm 10\%$, $\frac{1}{4}W$	327-1015
R8	Res. 220ohm, $\pm 5\%$, $\frac{1}{4}W$	327-1055
R9	Control, Centering, 2.5K	333-1044
R10	Control, Centering, 2.5K	333-1044
R11	Res. 2.2MEG, $\pm 10\%$, $\frac{1}{2}W$	326-1081
R12	Res. 3.3K, $\pm 10\%$, $\frac{1}{4}W$	326-1181
R13 \triangle	Res. 180ohm, $\pm 5\%$, $\frac{1}{2}W$	422-3182
R14	Res. 330ohm, $\pm 5\%$, 1W	326-1186
R15	Res. 330ohm, $\pm 5\%$, 1W	326-1186
R16 \triangle	Res. 180ohm, $\pm 5\%$, $\frac{1}{2}W$	422-3182
R17	Res. 1Meg, $\pm 10\%$, $\frac{1}{4}W$	327-1001
R18 \triangle	Res. 4.7K, $\pm 5\%$, $\frac{1}{4}W$	327-1049
R19 \triangle	Res. 4.7K, $\pm 5\%$, $\frac{1}{4}W$	327-1049
R20 \triangle	Res. Prec., 100K, $\pm 2\%$, $\frac{1}{2}W$	432-6101
R21 \triangle	Res. Prec., 100K, $\pm 2\%$, $\frac{1}{2}W$	432-6101

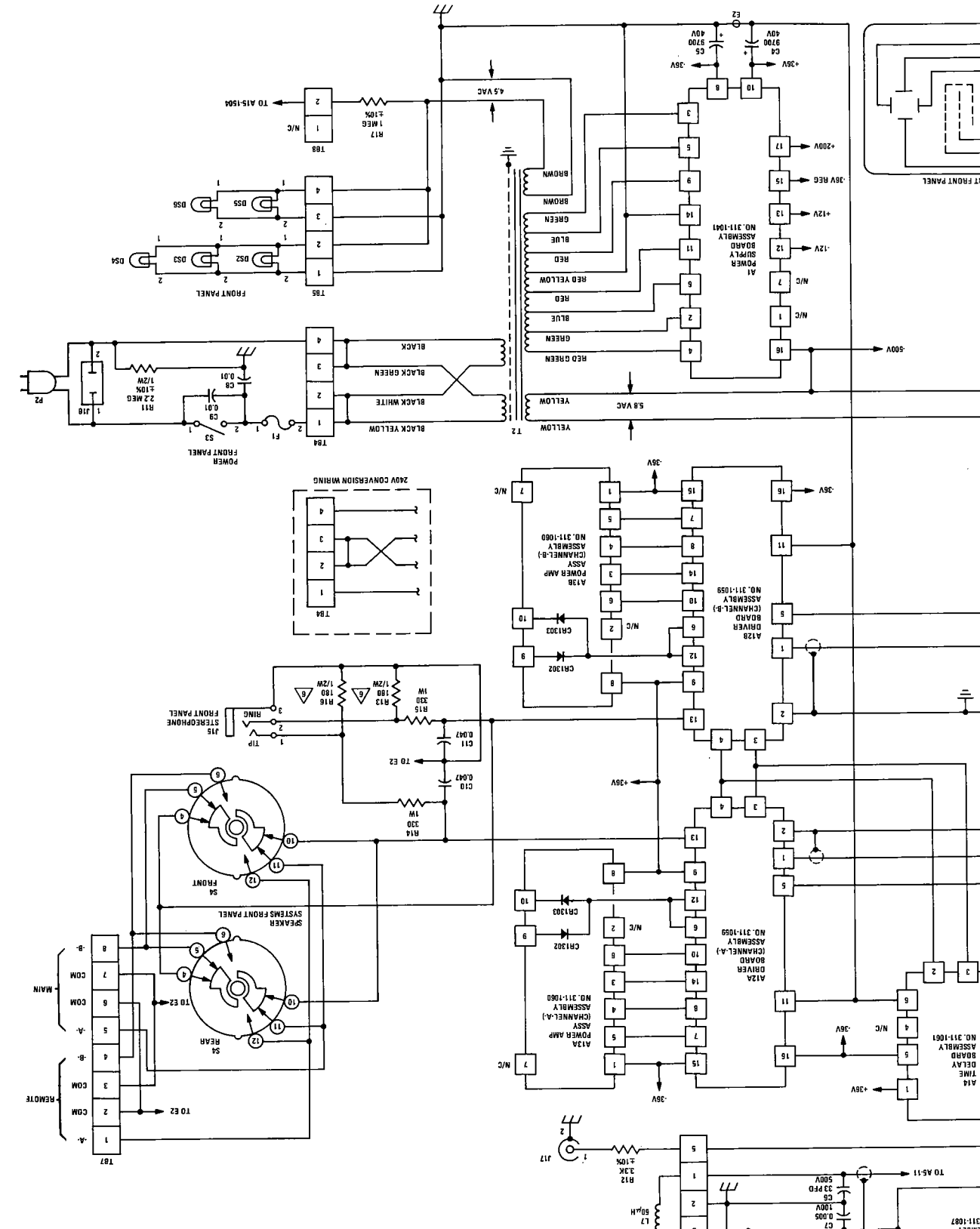

Unless otherwise noted:

- 1 All resistors are in ohms, 1/4 watt, ±5%
- 2 All capacitors in decimals and less than 1 are in μF
- 3 All other capacitors are PF
- 4 All inductors are in μH
- 5 R18, 19, 20, 21, 22 and 23 added at S/N 1501
- 6 R13 and R16 were 33 ohms, ±5%, 1W, P/N 326-1019 prior to S/N 1501

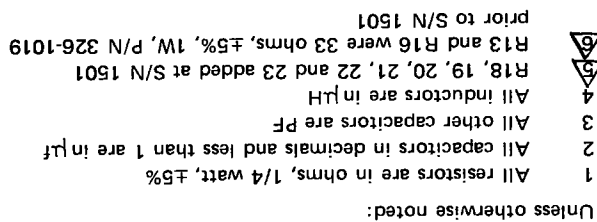

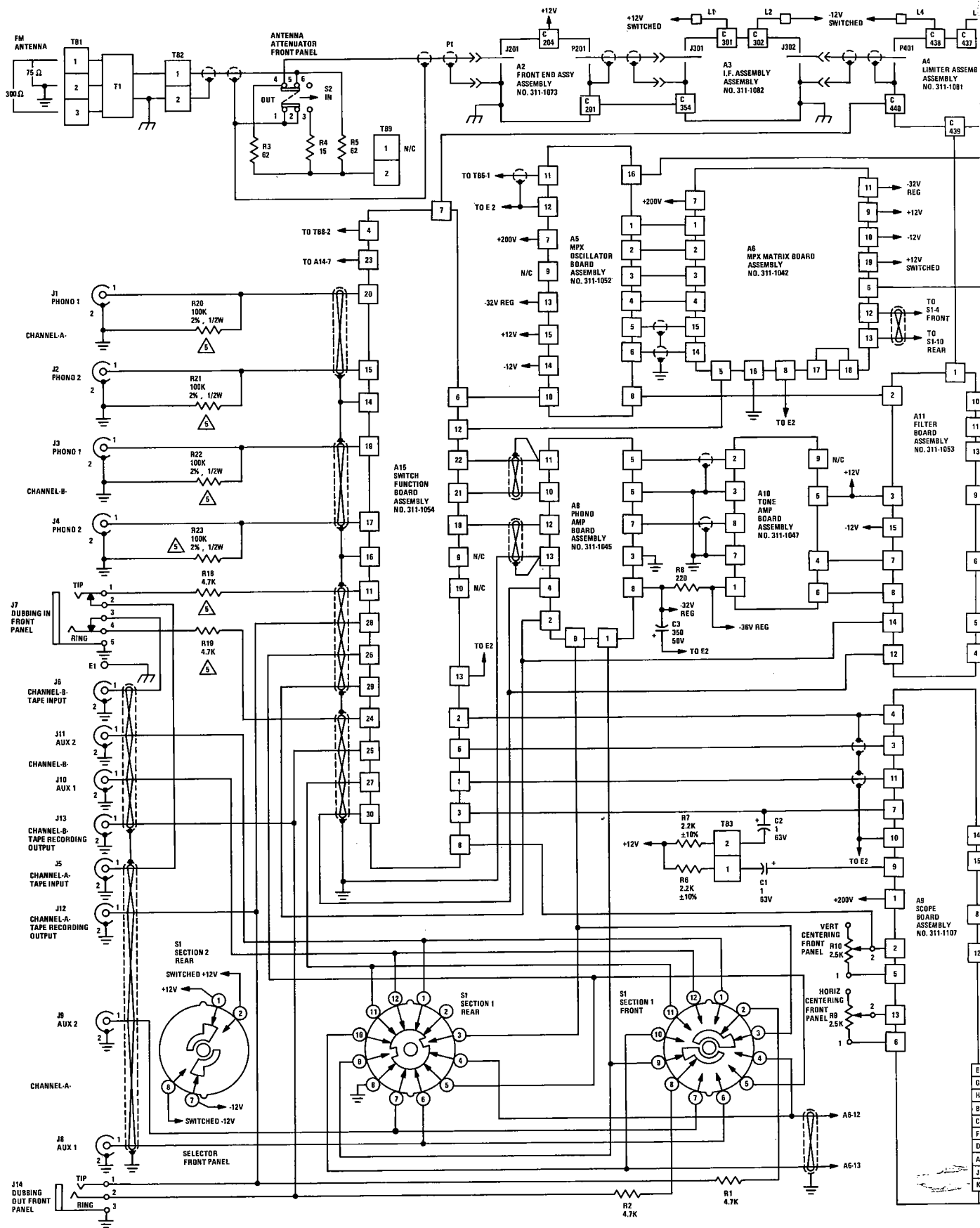

FIGURE 24 - MODEL 19 UNIT SCHEMATIC

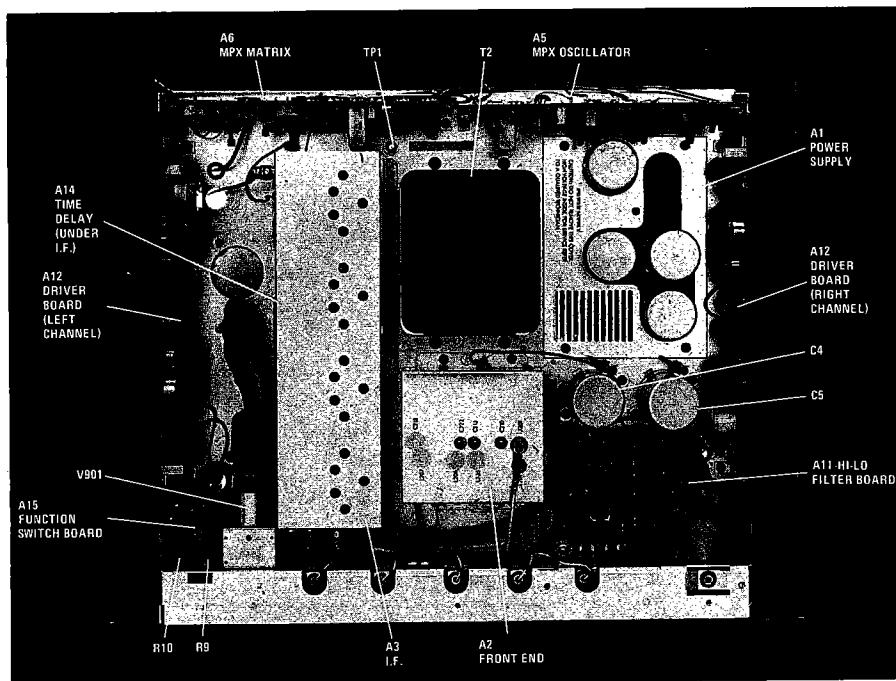

FIGURE 23A – MODEL 19 TOP VIEW

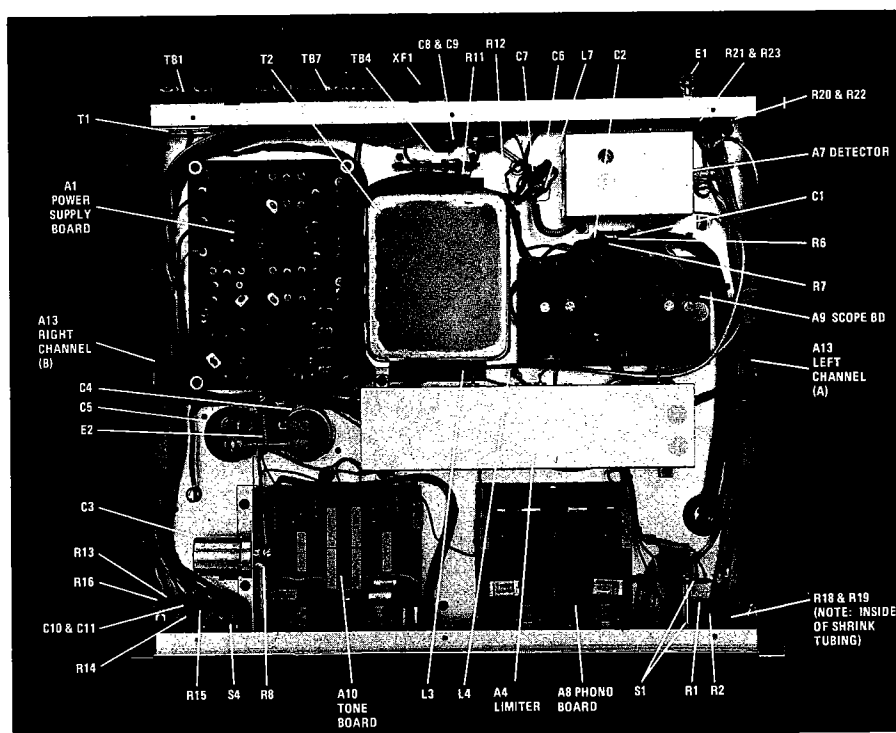

FIGURE 23B – MODEL 19 BOTTOM VIEW

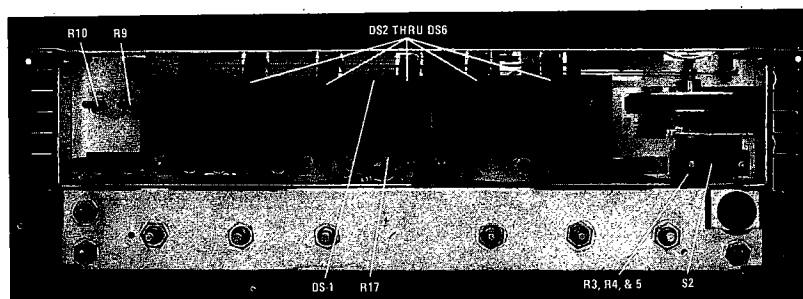
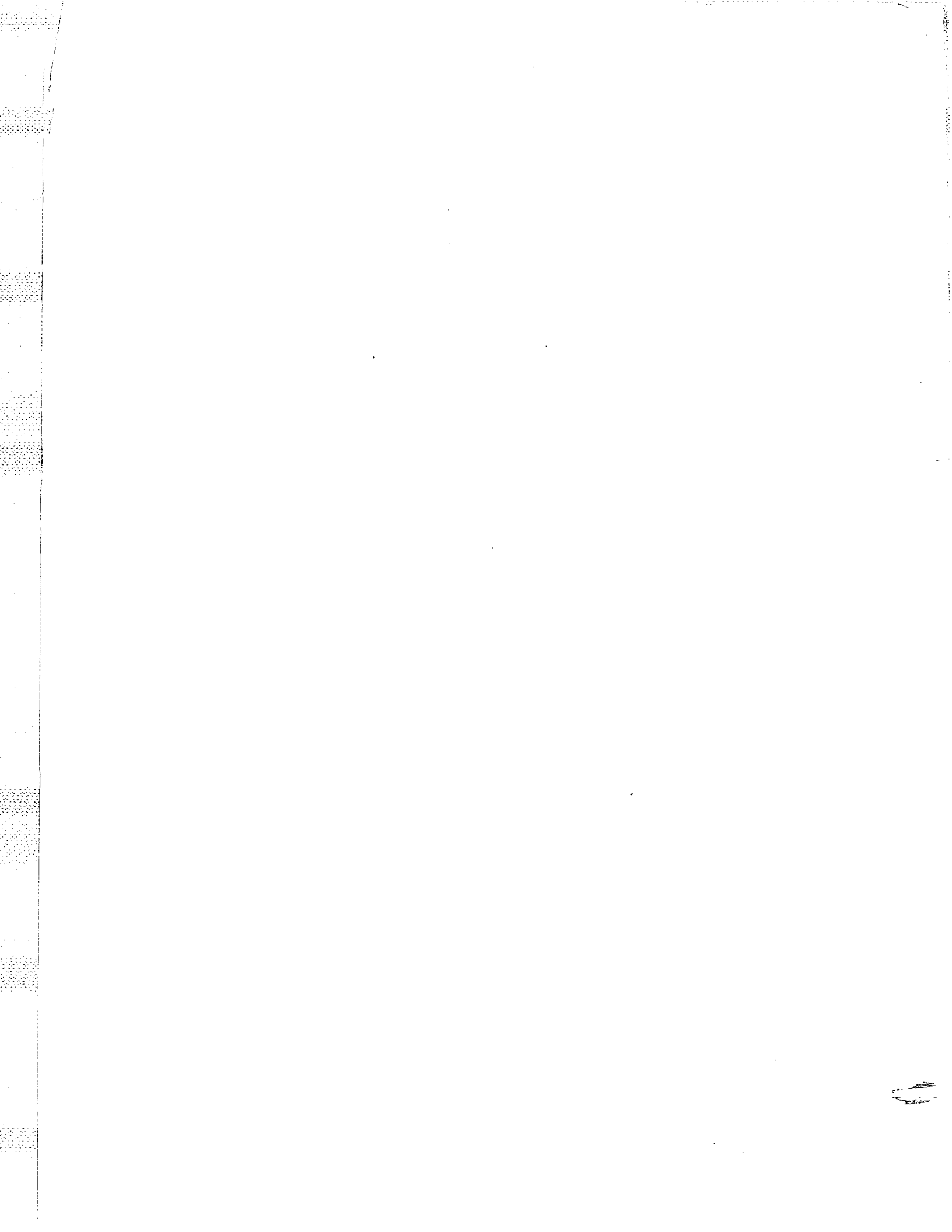



FIGURE 23C – MODEL 19 FRONT VIEW

marantz [®] SERVICE BULLETIN	model number	19	bulletin number	M-19-1
	for serial numbers	see text		
	subject	FM SIGNAL LEAKAGE THROUGH TAPE MONITOR FUNCTION		
	engineering approval	<i>Dawson Hally</i>		date

Recently, we have had some complaints of FM signal leakage when depressing the "Tape Monitor Switch" on the Model 19 receiver. This problem exists only when the "Tape In" jacks are unloaded, (no tape deck connected). If the customer will not be using a deck with the receiver, have him install shorting plugs at the "Tape In" jacks as this will eliminate the leakage.

Should further reduction of the signal be necessary, install a 47K resistor in parallel with the "Tape In" jack of each channel. Please note that this change will already be incorporated in all units beyond serial number 1699.



Reference Designation	Description and/or Remarks	Marantz Part Number
R22 	Res. Prec., 100K, $\pm 2\%$, $\frac{1}{2}W$	432-6101
R23 	Res. Prec., 100K, $\pm 2\%$, $\frac{1}{2}W$	432-6101
S1	Switch, "Selector" 5 Position	346-1016
S3	Power Switch	348-1004
S4	Switch, Speaker, 4 Position	346-1015
T1	Balun, Input	255-1020
T2	Power Transformer	252-1009
TP1	Jack, Phono	269-1010
V901	C.R.T. w/13 Pin Nixie Base	337-1000
XDS2 thru XDS6	Lamp Socket	268-1026
XF1	Fuse Post	342-1000
	Knob, 15/16 Diameter	260-1005
	Knob, Concentric, Rear	260-1006
	Knob, Concentric, Front	260-1007
	Knob, Control, Centering	260-1028
	Knob, Pushbutton	260-1078
	Phono Jack Strip - 6 Jacks	269-1013
	A.C. Socket (Receptacle)	268-1001
	Window, Tinted	261-1004
TB-7	Terminal Block - Speaker	287-1000
TB-1	Terminal Block - Antenna	287-1001
E1	Binding-Post - Ground	287-1002
	Foot, Black	290-1018
	Tuning Knob Assembly	311-1043
	Knob Set Screws #6-32 x 1/4	273-1004
	Dot Plug Button - for Rear of Top Cover	564-1001
	Insulator - Between Top Cover and Dialpan	290-1111
	Cover - Top	295-1189
	Cover - Bottom	295-1190
	Dial Window Frame	260-1069

Reference Designation	Description and/or Remarks	Marantz Part Number
	Scope (C.R.T.) Reticule	260-1080
	Dial Cord	262-1001
	Dial Pointer	262-1004
	Dial Cord Spring	271-1023
	Pivot Screw - for Tuning Knob	271-1022
	C.R.T. Spring	271-1025
	C.R.T. Rubber Band	290-1015
	Line Cord	292-1019
	Chassis Shield - Mtg. Bracket for C3	295-1206
	Front Panel Ass'y - Complete	311-1090-1
	Front Panel - only	260-1066

 R13 and R16 were 33ohms, $\pm 5\%$, 1W, P/N 326-1019 prior to S/N 1501.

 R18, 19, 20, 21, 22 and 23 added at S/N 1501.

 F1 is 2A, 250V, SB fuse P/N 451-1006 in 240 volt units.

MARANTZ CO., INC. ● P.O. Box 99 ● SUN VALLEY, CALIFORNIA ● 91352
A WHOLLY-OWNED SUBSIDIARY OF SUPERSCOPE INC., SUN VALLEY, CALIFORNIA 91352