

Service Manual

PM-KI-PEARL /N1B/U1B

PM-13S2 /FN/K1G

Integrated Amplifier

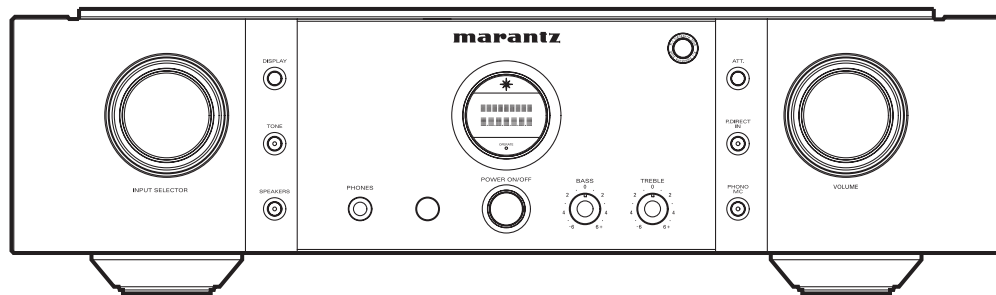

PM-KI-PEARL
PM-13S2

TABLE OF CONTENTS

SECTION	PAGE
1. TECHNICAL SPECIFICATIONS.....	1
2. CAUTION.....	1
3. ALIGNMENTS.....	2
4. SERVICE MODE.....	4
5. PROTECTION MODE.....	6
6. MAIN MICROPROCESSOR (QU01) UPDATE PROCEDURE.....	8
7. WIRING DIAGRAM.....	23
8. BLOCK DIAGRAM.....	25
9. SCHEMATIC DIAGRAM.....	27
10. PARTS LOCATION.....	39
11. EXPLODED VIEW AND PARTS LIST.....	65
12. MICROPROCESSOR AND IC DATA.....	71
13. ELECTRICAL PARTS LIST.....	77
14. AFTER REPLACEMENT OF U-PRO OR FLASH ROM.....	94

Please use this service manual with referring to the user guide (D.F.U.) without fail.
修理の際は、必ず取扱説明書を準備し操作方法を確認の上作業を行ってください。

marantz®

PM-KI-PEARL PM-13S2

Ver. 2

Please refer to the
MODIFICATION NOTICE.

MARANTZ DESIGN AND SERVICE

Using superior design and selected high grade components, **MARANTZ** company has created the ultimate in stereo sound. Only original **MARANTZ** parts can insure that your **MARANTZ** product will continue to perform to the specifications for which it is famous.

Parts for your **MARANTZ** equipment are generally available to our National Marantz Subsidiary or Agent.

ORDERING PARTS :

Parts can be ordered either by mail or by Fax.. In both cases, the correct part number has to be specified.

The following information must be supplied to eliminate delays in processing your order :

1. Complete address
2. Complete part numbers and quantities required
3. Description of parts
4. Model number for which part is required
5. Way of shipment
6. Signature : any order form or Fax. must be signed, otherwise such part order will be considered as null and void.

USA

MARANTZ AMERICA, INC
100 CORPORATE DRIVE
MAHWAH, NEW JERSEY 07430
USA

EUROPE / TRADING

D&M EUROPE B. V.
P. O. BOX 8744, BUILDING SILVERPOINT
BEEMDSTRAAT 11, 5653 MA EINDHOVEN
THE NETHERLANDS
PHONE : +31 - 40 - 2507844
FAX : +31 - 40 - 2507860

CANADA

D&M Canada Inc.
5-505 APPLE CREEK BLVD.
MARKHAM, ONTARIO L3R 5B1
CANADA
PHONE : 905 - 415 - 9292
FAX : 905 - 475 - 4159

JAPAN

D&M Holdings Inc.
D&M BUILDING, 2-1 NISSHIN-CHO,
KAWASAKI-KU, KAWASAKI-SHI,
KANAGAWA, 210-8569 JAPAN

株式会社 ディーアンドエムホールディングス

本 社 〒210-8569
神奈川県川崎市川崎区日進町2-1 D&Mビル



KOREA

D&M SALES AND MARKETING KOREA LTD.
CHUNG JIN B/D., #1001,
53-5, WONHYORO 3 GA, YONGSAN-GU,
SEOUL, 140-719, KOREA
PHONE : +82 - 2 - 323 - 2155
FAX : +82 - 2 - 323 - 2154

CHINA

D&M SALES AND MARKETING SHANGHAI LTD.
ROOM.808 SHANGHAI AIRPORT CITY TERMINAL
NO.1600 NANJING (WEST) ROAD, SHANGHAI,
CHINA. 200040
TEL : 021 - 6248 - 5151
FAX : 021 - 6248 - 4434

NOTE ON SAFETY :

Symbol  Fire or electrical shock hazard. Only original parts should be used to replaced any part marked with symbol  . Any other component substitution (other than original type), may increase risk of fire or electrical shock hazard.

安全上の注意 :

 がついている部品は、安全上重要な部品です。必ず指定されている部品番号のものを使用して下さい。

SHOCK, FIRE HAZARD SERVICE TEST :

CAUTION : After servicing this appliance and prior to returning to customer, measure the resistance between either primary AC cord connector pins (with unit NOT connected to AC mains and its Power switch ON), and the face or Front Panel of product and controls and chassis bottom.

Any resistance measurement less than 1 Megohms should cause unit to be repaired or corrected before AC power is applied, and verified before it is return to the user/customer.

Ref. UL Standard No. 60065.

In case of difficulties, do not hesitate to contact the Technical Department at above mentioned address.

1. TECHNICAL SPECIFICATIONS

Power output (20 Hz – 20 kHz simultaneous drive of both channels).....(8Ω load) 90 W x 2 [N1B / U1B / FN]	
..... 80 W x 2 [K1G]	
.....(4Ω load) 140 W x 2 [N1B / U1B / FN]	
..... 130 W x 2 [K1G]	
Headphone rated output (When speaker rated output set to 8 Ω load)..... 120mW x 2 (32 Ω load)	
Total harmonic distortion (20Hz – 20kHz simultaneous drive of both channels, 8 Ω load)..... 0.05 %	
Output band width (8Ω load, 0.05%)5 Hz ~ 40 kHz	
Frequency response (CD, 1W, 8Ω load)	
..... 5 Hz ~ 100 kHz ±3 dB	
Dumping factor (8Ω load, 20Hz – 20kHz)..... 100	
Input sensitivity/Input impedance	
PHONO (MC)..... 270 μV/100 Ω	
PHONO (MM).....2.7 mV/47 kΩ	
CD/LINE.....240 mV/20 kΩ	
P.DIRECT IN.....1.7 V/20 kΩ	
Output voltage/Output impedance	
PRE OUT..... 1.7 V/220 Ω	

Maximum allowed PHONO input (1kHz)	
MC..... 15 mV	
MM 150 mV	
RIAA deviation (20Hz ~ 20kHz) ±0.5 dB	
S/N (IHF-A, 1W, 8Ω load)	
PHONO MC (0.5mV input)..... 75 dB	
PHONO MM (5mV input) 86 dB	
CD/LINE (500mV input) 89 dB	
Tone control	
Bass (50Hz) ±10 dB	
Treble (20kHz) ±10 dB	
Power requirement	
(U.S.A.)AC 120 V 60 Hz	
(Europe)AC 230 V 50/60 Hz	
(Japan).....AC 100 V 50/60 Hz	
(China)AC 220 V 50 Hz	
Power consumption	
(EN60065 7th Ed.) 220 W	
(UL60065) 220 W	
(J60065)..... 220 W	

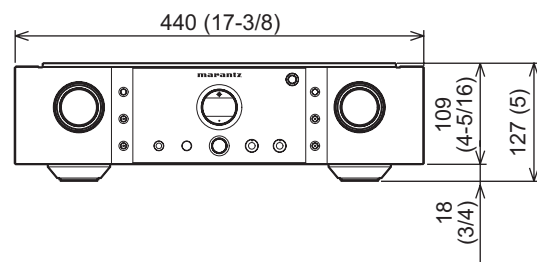
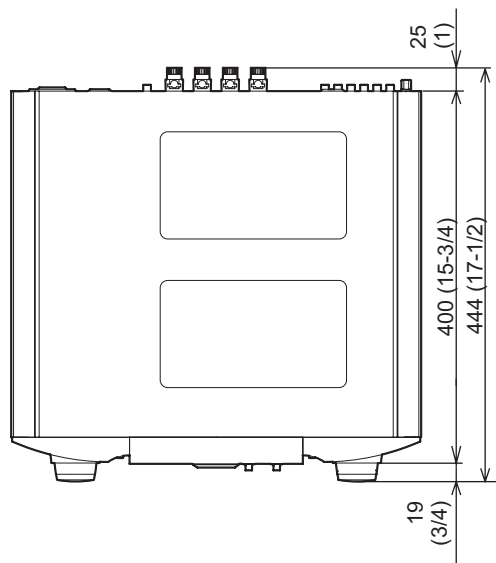

2. CAUTION

The layout of this amplifier is well concerned for sound quality.

1. When screws and washers are removed, those parts must be set to the same places.
2. When wires are removed, the wires must be installed in the same roots, same places.
3. Do not hold the side panel (007D) to move the unit when the unit is disassembled.

2. 注意

当機は音質を考慮したレイアウトになっています。

1. ネジやワッシャ類を取り外した場合、元の位置に取り付けてください。
2. ワイヤ類を取り外した場合の配線ルートは、元のルート通りに戻してください。
3. 当機を分解した状態で移動するときは、サイドパネル (007D) を持たないでください。

3. ALIGNMENTS

Idling Current Adjustment

アイドル電流調整

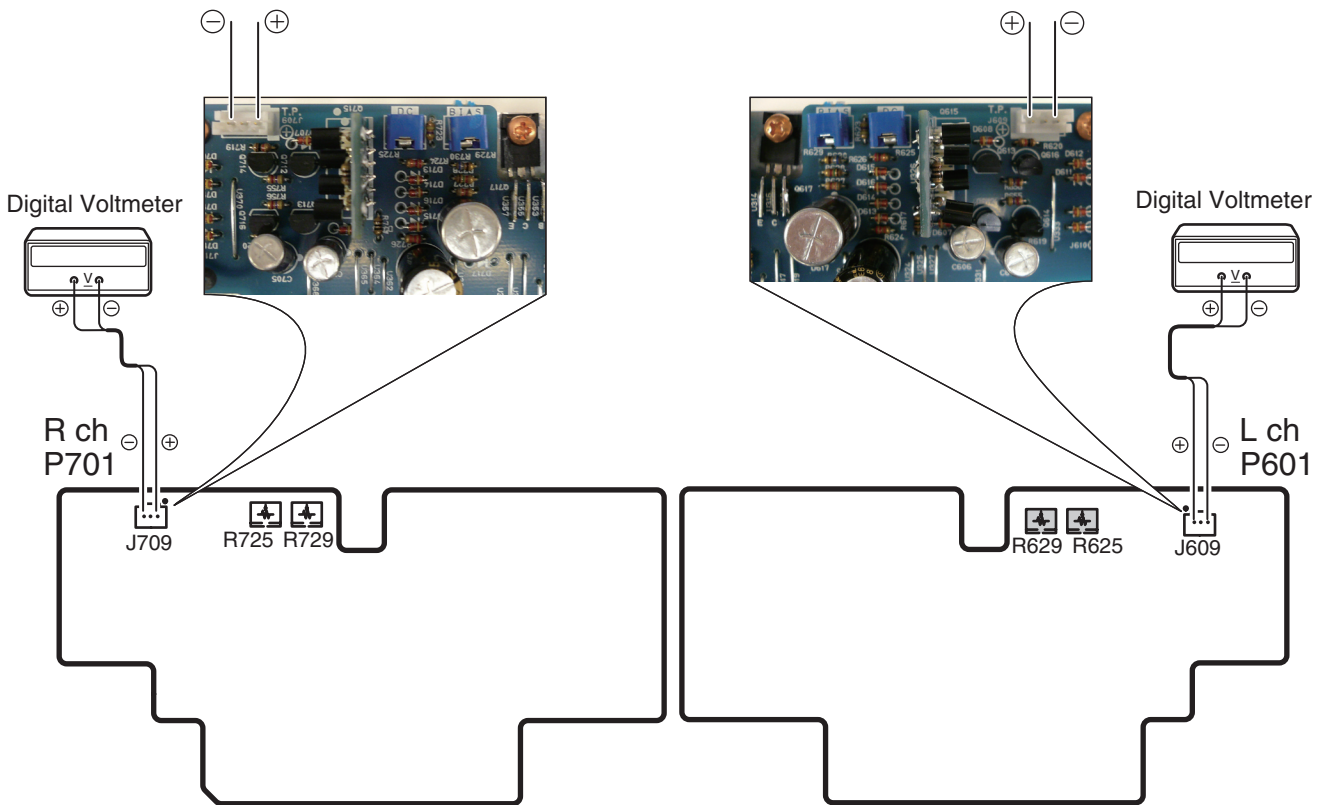

1. Digital voltage is connected with Lch/Rch of the speaker terminal of a rear panel respectively. "+" of Connect Digital Voltage is connected to the "+" of the terminal. "-" of Connect Digital Voltage is connected to the "-" of the terminal.
2. "+" of Connect Digital Voltage is connected to the **No.1 pin** and connected "-" to **No.3 pin** of **J609 (J709)**.
3. Function is CD. Volume is set as $-\infty$. Do not connect anything with the input terminal.
4. Before turning on the power, **R625** and **R729** have been center then **R629** and **R729** have been counter clockwise turned with the adjustment driver.

1. リアパネルの SPEAKER のLchとRchの端子にデジタルボルトメーターを接続します。デジタルボルトメーターは、Lch および Rch の "+" を "+" に、 "-" を "-" に接続します。
2. **P601/P701** 基板の **J609/J709** にデジタルボルトメーターを接続します。デジタルボルトメーターは **J609/J709** の 1 番ピンを "+"、3 番ピンを "-" に接続します。
3. PM-KI-PEARL / PM-13S2 のファンクションは CD にして、ボリュームは $-\infty$ に、入力端子には何も接続しないでください。
4. 電源を投入する前に、半固定抵抗 **R625** と **R725** はセンターに合わせ、**R629** と **R729** を、調整ドライバーで反時計方向に回しきってください。

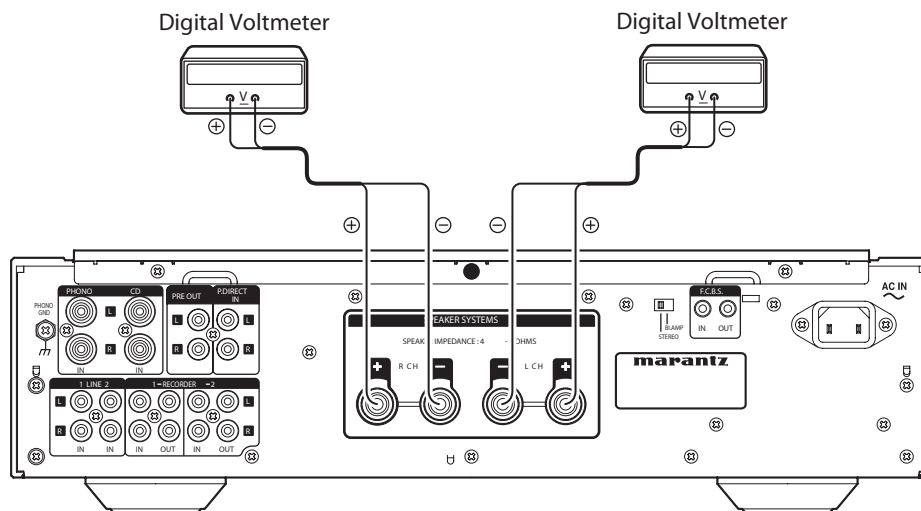

DC Offset Voltage Adjustment

5. First, adjust the DC offset voltage with the variable resistor **R625** and **R725** on the PCB (**P601/P701**).
6. Turn on the power. Turn on the button of SPEAKERS.
7. After turning on the speaker relay, with seeing the digital voltage meter connected with the Lch terminal turn the variable resistor slowly to adjust the DC offset adjustment with **R625**. Next, with seeing the digital voltage meter connected with the Rch terminal turn the variable resistor slowly to adjust the DC offset adjustment with **R725**.
 - Turn **R625(R725)** clockwise to decrease the DC offset voltage. And counter clockwise to increase.
 - The voltage changes delaying, and turn slowly.
 - The adjustment value of DC offset voltage is $0\text{mV}\pm 10\text{mV}$ each.

Idling Current Adjustment

8. Next, Adjust the Idling Current.
 9. Turn on the power. After 2 minutes, with seeing the digital voltage meter turn the variable resistor clockwise slowly to adjust the idling current. Idling adjustment with **R629**. **R729** is similarly adjusted.
 - Turn **R629 (R725)** clockwise to increase the idling current.
 - The adjustment value of idling current is 5.0mV (25mA) $\pm 0.5\text{mV}$ (2.5mA) each.
 10. After 7 minutes, repeat the same procedure as 9.
 - The adjustment value of idling current is 11.0mV (55mA) $\pm 0.5\text{mV}$ (2.5mA) each.
- Adjustment is completed.
11. Remove connection cable, attach the top cover.

DC オフセット電圧調整

5. 最初に、**P601/P701** 基板上の半固定抵抗 **R625** と **R725** でDCオフセットを調整します。
6. 電源を投入し、SPEAKERS のボタンをONしてください。
7. スピーカーリレーがオンした後、SPEAKER SESTEM 端子の Lch に接続したデジタルボルトメーターの電圧値を監視しながら、**R625** をゆっくりとまわしてください。次に Rch に接続したデジタルボルトメーターの電圧値を監視しながら、**R725** をゆっくりとまわしてください。
 - **R625** と **R725** を時計方向に回すとオフセット電圧が減少します、反対に回すと増加します。
 - 電圧は遅れて変化しますので、ゆっくり回してください。
 - オフセット電圧の調整値はそれぞれ " $0\text{mV}\pm 10\text{mV}$ " 以内にします。

アイドリング電流調整

8. 次にアイドリング電流を調整します。
9. 電源を投入してから2分経過後、**P601** 基板の **J609** に接続したデジタルボルトメーターの電圧値を監視しながら半固定抵抗 **R629** をゆっくりと時計方向に回してください。次に **P701** 基板の **J709** に接続したデジタルボルトメーターの電圧値を監視しながら半固定抵抗 **R729** をゆっくりと時計方向に回してください。
 - **R625** と **R725** を時計方向に回すとアイドリング電流が増加します。
 - アイドリング電流の調整値はそれぞれ " $5.0\text{mV}\pm 0.5\text{mV}$ " 以内にします。
10. さらに"7分"経過後、上記9の手順でもう一度調整します。
 - アイドリング電流の調整値はそれぞれ " $11.0\text{mV}\pm 0.5\text{mV}$ " 以内にします。

以上で調整は完了です。

11. デジタルボルトメーターの接続を外し、トップカバーを取り付けます。

4. SERVICE MODE

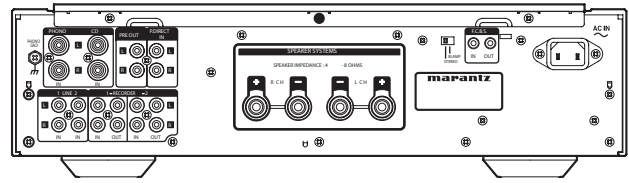
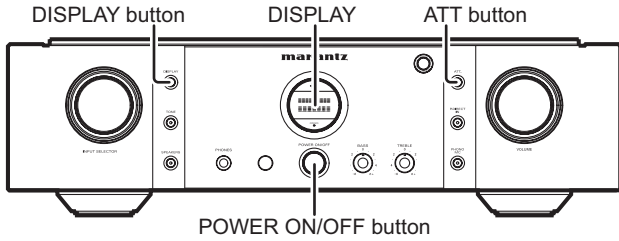

- To enter the Service Mode, press the **POWER ON/OFF** button with pressing the **DISPLAY** and **ATT** buttons to turn on the unit. (Or when the remote code "166363" is received while power is ON.)

When into the Service Mode, the memory is cleared and the unit is initialized.

- The Model name and Version number are displayed on the Front LCD.

Whenever press the **DISPLAY** button, the display changes as follows.

Turn off power to quit service mode.

- 本体の **DISPLAY** ボタンと **ATT** ボタンを押しながら **POWER ON/OFF** ボタンを押します。

(または、電源 ON 中にリモコンコード "166363" を受信します。) これでサービスモードに入ります。

注意：サービスモードに入ると、全ての設定がクリアされ出荷状態になります。

- 始めにモデル名、バージョンが表示されます。

DISPLAY ボタンを押すたびに下記の表示となります。

POWER ON/OFF ボタンを押し、電源を切るとサービスモードが解除されます。

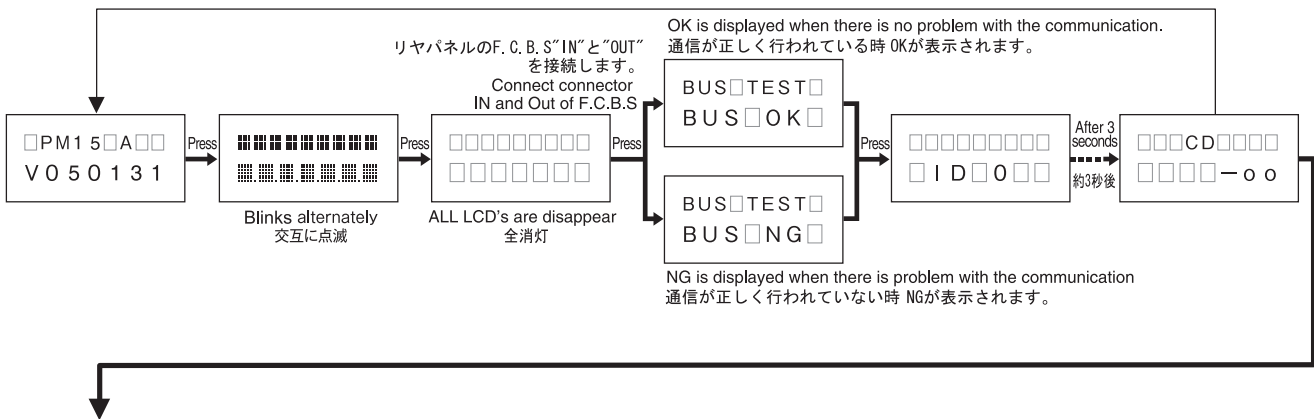

THE TRIM CHECK MODE

- Press **TONE** button. (1st)
Volume Level is displayed.

(1st)

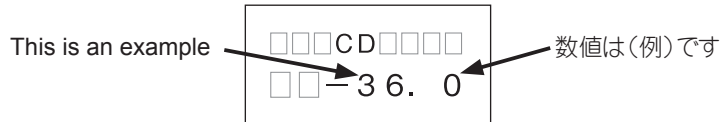

After, whenever press the **TONE** button, TRIM adjustment function works and output level changes according to the display.

Whenever press the **TONE** button, the display changes as follows and output level changes according to the display.

TRIM チェックモード

- TONE** ボタンを押します。(1回目)
ディスプレイに音量が表示されます。

以降、**TONE** ボタンを押すごとにトリム調整機能が働き表示に従い出力レベルが変化します。

TONE ボタンを押すごとに下記のように表示が変わり、表示に従い出力レベルが変わります。

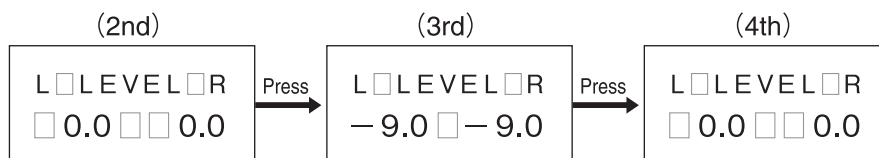

TRIM check mode is completed.

TRIM チェックモードは終了です。

2. Press **DISPLAY** button, the display will be the following.

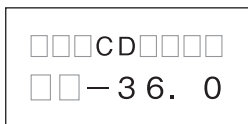

2. **DISPLAY** ボタンを押します。下記の表示になります。

3. Press **DISPLAY** button, the display will be the following.

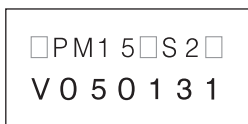

3. **DISPLAY** ボタンを押します。下記の表示になります。

4. Turn off power to quit service mode.
Service mode can be ended if turn off power from every procedure.
The memory is cleared and the unit is initialized.

4. **POWER ON/OFF** ボタンを押し、電源を切ります。サービスモードが解除されます。
サービスモードはどの手順からも電源を切ると終了することができます。
本体の設定は全て下記の出荷状態になります。

Initial settings

出荷状態内容

ID No.: 0	INPUT SELECTOR: CD	VOLUME: -∞
SIDE ILLUMINATION: ON	DISPLAY: ON	ATT: OFF
LEVEL TRIM: 0.0 (L/R)	TONE: OFF	SPEAKER : OFF
ATT: -20dB	P.DIRECT: OFF	PHONO MC:OFF

Be sure to set up manually.
MODE SW on Rear panel: STEREO
POWER ON/OFF SW: OFF

下記は、手動で設定
MODE SW : STEREO (必ず設定)
POWER ON/OFF SW : OFF

ERROR MESSAGES

	Error	Contents	Measure
1	ERROR 02	The units of ID No.2 overlaps.	ID number is changed into the ID No. not overlapping.
2	ERROR 03	The unit of ID No.3 overlaps.	
3	ERROR 04	The unit of ID No.4 overlaps.	
4	ERROR 11	The unit of ID No.2 to No.4 cannot communicate with the unit of ID No.1.	<ul style="list-style-type: none"> If the unit ID number 1 is not turn on, turn on the unit ID No.1. Check the remote cable is connected correctly.
5	ERROR 12	The unit of ID No.1 cannot communicate with the unit of ID No.2 to No.4.	<ul style="list-style-type: none"> ID No. is changed into ID No. not overlapping. Check the remote cable is connected correctly.

エラーメッセージ

	表示	内容	対策
1	ERROR 02	ID 番号 2 のアンプが重複しています。	ID 番号が重複しないように ID 番号を設定してください。
2	ERROR 03	ID 番号 3 のアンプが重複しています。	
3	ERROR 04	ID 番号 4 のアンプが重複しています。	
4	ERROR 11	ID 番号 2 ~ 4 のアンプが ID 番号 1 のアンプと通信できません。	<ul style="list-style-type: none"> ID 番号 1 のアンプに電源が入っていない場合は電源を入れてください。 リモートケーブルが正しく接続されているか確認してください。
5	ERROR 12	ID 番号 1 のアンプが ID 番号 2 ~ 4 のアンプと通信できません。	<ul style="list-style-type: none"> ID 番号 1 のアンプが重複している場合は ID 番号を正しく設定してください。 リモートケーブルが正しく接続されているか確認してください。

5. PROTECTION MODE

Explanation of microprocessor (QU01) [PROT-1 (pin54) and PROT-2 (pin53)].

[A] The PROT-1(pin54) is the port to detect the following abnormalities of the Power AMP

1. Detection of an abnormality in the DC offset voltage from the Speaker Output terminal.
If the voltage from the Speaker Output terminal exceeds approximately $\pm 1.2V$ (DC), Q954 or Q955 will turn on and the signal from the PROT-1 terminal will change to L from H.
2. Detection of an abnormal current from the power transistors (Q622, Q623, Q722, Q723).
If an electric current of over 10A flows in Q622 or Q623, Q624, Q625 and Q957 turn on, and the signal from the PORT-1 terminal will change to L from H.
If an electric current of over 10A flows in Q722 or Q723, Q724, Q725 and Q957 turn on, and the signal from the PORT-1 terminal will change to L from H.
3. Detection of an abnormal temperature of the Heat Sink.
If the temperature of the Heat Sink exceeds approximately +110 degrees C, the posistor (R672 and R772) will turn on Q956 and the signal from the PROT-1 terminal will change to L from H.

If any of the above three abnormalities is detected, the signal from the PROT-1 terminal will change to L from H, and the protection circuit will be activated, the signal from the SPK_OUT (pin40) changing to L from H and the speaker relays L901 immediately turned off.

What this protection operation results in after this depends on how long the signal from the PROT-1 has to remain L.

- If the PROT-1 (pin54) recovers to "H" within as short a period of time as one second or less.
The message "PROTECT" flashes on the display, thereby indicates that the protection circuit has come into operation and automatically turns down the volume.
The protection circuit is deactivated after approximately 8 seconds, so that readjusting the volume will allow normal use of the unit again. This protection operation is intended for the situation wherein the user has misused the unit temporarily and automatically resets the unit while the amp circuit is functioning properly.
- If the PROT-1 (pin54) remains L for more than one second.
The amp will be powered off by the POW-1 (pin25) changing to L from H and Power relay L852 turned off. Then, the OPERATION indicator flickers, thereby indicating that an error has occurred. This protection operation is intended for a failure in the amp circuit and immediately turns the power off to avoid the risk of any damage. Depending on how the user is handling the unit, this operation may be performed no matter if the amp is functioning properly.

5. PROTECTION動作について

マイコン(QU01)のPROT-1 (pin54) とPROT-2 (pin53)の説明。

[A] PROT-1(pin54)は、パワーアンプの下記の異常動作を検出するポート

1. スピーカー出力端子のDCオフセット電圧の異常電圧を検出。
スピーカー出力端子が約 $\pm 1.2V$ (DC) を超えるとQ954もしくはQ955がONして、PROT-1端子が"H→L"になる。
2. パワートランジスタ(Q622, Q623, Q722, Q723)の異常電流を検出。
Q622もしくはQ623に約10Aを超える電流が流れるとQ624, Q625, Q957がONして、PROT-1端子が"H→L"になる。
Q722もしくはQ723に約10Aを超える電流が流れるとQ724, Q725, Q957がONして、PROT-1端子が"H→L"になる。
3. ヒートシンクの異常温度を検出。
ヒートシンクの温度が約110℃を超えると、ポジスター(R672, R772)によってQ956がONして、PROT-1端子が"H→L"になる。

1.~3.のいずれかの異常検出でPROT-1端子が"H→L"になると保護回路が動作してSPK_OUT (pin40)を"H→L"にして、即座にスピーカーリレーL901をOFFにします。

このPROTECTION動作はPROT-1端子が"L"になっている時間によって、その後の動作が異なります。

- PROT-1 (pin54)が1秒以内の短時間の間に"H"に復帰した場合。
ディスプレイ部に"PROTECT"の文字が点滅し、PROTECTION動作になったことを知らせ、自動的にボリュームを下げます。
約8秒後に保護回路が解除しますのでボリュームを再調整すればそのまま使用することができます。
これは、ユーザーが一時的に使用法を誤った場合を想定したPROTECTION動作で、アンプ回路は故障していない場合に自動復帰する動作です。
- PROT-1 (pin54)が1秒以上"L"になっている場合。
POW-1 (pin25)を"H→L"にして、電源リレーL852をOFFし、アンプの電源をシャットダウンします。
このときOPERATEインジケータが点滅(1秒間に約2回)し、異常が起きたことを表示します。
これは、アンプ回路の故障を想定したPROTECTION動作で、危険回避のため即座に電源を切る動作です。
ユーザーの使用状況によっては、アンプが故障していてもこの状態になる可能性もあります。
アンプが故障しているかどうかを確認するには、一旦電源SWを切り1分ほど待ってから電源SWを再投入します。
この操作でPROTECTION動作が解除します。
電源SWを再投入してもPROT-1 (pin54)が"L"の異常状態の場合は、約2秒後に再びシャットダウンしてOPERATEインジケータが点滅します。
電源を再投入してもPROTECTION動作が解除されない場合は、アンプ回路が故障していると考えられます。

To check if the amp is in order, switch off the unit and switch it on again one minute later. This action will deactivate the protection operation. If the PROT-1 (pin54) remains "L", which constitutes an abnormality, the unit shuts down approximately 2 seconds later and the OPERATION indicator starts flickering.

If the protection operation will not be deactivated after the power is turned on again, the amp circuit may be broken.

[B] The PROT-2 (pin53) is the port to detect abnormalities of the power supply circuit

1. Detection of an abnormality in the power amp power supply circuit.

This port monitors the midpoint voltage of the power amp power supply between +50V and -50V. If the voltage at the connection point of R829 and R830 exceeds DC $\pm 1.2V$, Q823 or Q824 will turn on to change the signal from the PROT-2 (pin53) to L from H.

2. Detection of an abnormality in the preamp power supply circuit.

This port monitors the midpoint voltage between +30V and -30V. If the voltage at the connection point of R823 and R824 exceeds DC $\pm 1.2V$, Q821 or Q822 will turn on to change the signal from the PROT-2 (pin53) to L from H.

3. Detection of an abnormality in the function relay power supply circuit.

If the +24V of the relay power supply receives an electric current of over 120mA, Q831 and Q834 will turn on to change the signal from the PORT-2 (pin53) to L from H.

4. The Fuse (F851) inside blows, the signal from the PROT-2 (pin53) terminal will be changed to L from H.

If any of the above four abnormalities is detected, the signal from the POW-1 (pin25) changing to L from H, the power relay L852 will be turned off and the unit will be shut down. Then, the OPERATE indicator flickers and indicates that an abnormality has occurred.

When the OPERATE LED enters the state of blinking eight times a second, it doesn't return to the normally state.

Because, when the power supply is turned on again, it is dangerous.

Return to normally operation.

1. Turn off **POWER ON/OFF** button.
2. One minute after, **POWER ON/OFF** button is turned on while pushing at the same time as **DISPLAY** button with **ATT** button.
3. The model name and the version are displayed on the display.
4. Then, turn off **POWER ON/OFF** button. Next, it starts with the factory shipped when turning on power.

[B] PROT-2 (pin53) は、電源回路の異常を検出するポート

1. パワーアンプ用電源回路の異常を検出。
パワーアンプ用電源の +50V と -50V の中点電圧を監視し、R829 と R830 の接続点の電圧が約 $\pm 1.2V$ (DC) を超えると、Q823 もしくは Q824 が ON して PROT-2 (pin53) が "H→L" になる。
2. プリアンプ用電源回路の異常を検出。
プリアンプ用電源の +30V と -30V の中点電圧を監視し、R823 と R824 の接続点の電圧が約 $\pm 1.2V$ (DC) を超えると、Q821 もしくは Q822 が ON して PROT-2 (pin53) が "H→L" になる。
3. ファンクションリレー用電源回路の異常を検出。
リレー用電源の +24V に約 120mA を超える電流が流れると、Q831, Q834 が ON して PROT-2(pin53) が "H→L" になる。
4. F851 FUSE が切れている場合、Q835 が ON し、PROT-2 (pin53) が "H→L" になる。

1.~4. のいずれかの異常を検出すると、POW-1 (pin25) を "H→L" にして、電源リレー L852 を OFF しシャットダウンします。このとき OPERATE インジケータが点滅 (1秒間に約8回) し、異常が起きたことを表示します。

これは、アンプ回路もしくは電源回路の故障を想定した PROTECTION 動作で、危険回避のため即座に電源を切る動作です。

OPERATE インジケータが 1秒間に約8回の速い点滅状態になると、電源が再投入できないようになります。

これは、電源を再投入することによる危険を回避するためメモリーに書き込まれるためです。

電源を投入できるようにするためには、メモリークリアの処理を行ってください。

メモリークリアの手順

1. まず、電源を OFF にしてください。
2. 1分ほど待ってから、本体の **DISPLAY** ボタンと **ATT** ボタンを押しながら **POWER ON/OFF SW** を押し電源を投入します。これでサービスモードに入ります。
3. ディスプレーにモデル名とバージョンが表示されます。
4. **POWER ON/OFF SW** を押し電源を切ると、メモリーがクリアされます。この操作で電源が投入できるようになりますが、この操作をすると全ての設定がクリアされ出荷状態に戻りますのでご注意ください。

6. MAIN MICROPROCESSOR (QU01) UPDATE PROCEDURE

Necessary Equipment

- Windows PC (Windows2000 or WindowsXP) with COM port
- RS232C cable straight type (9pin female - 9Pin female)
- Update Disc (90M-PM15S2CDR)
- DATA UPDATE KIT (part no.: 90M-PM11S1JIG)

6.1. Connection

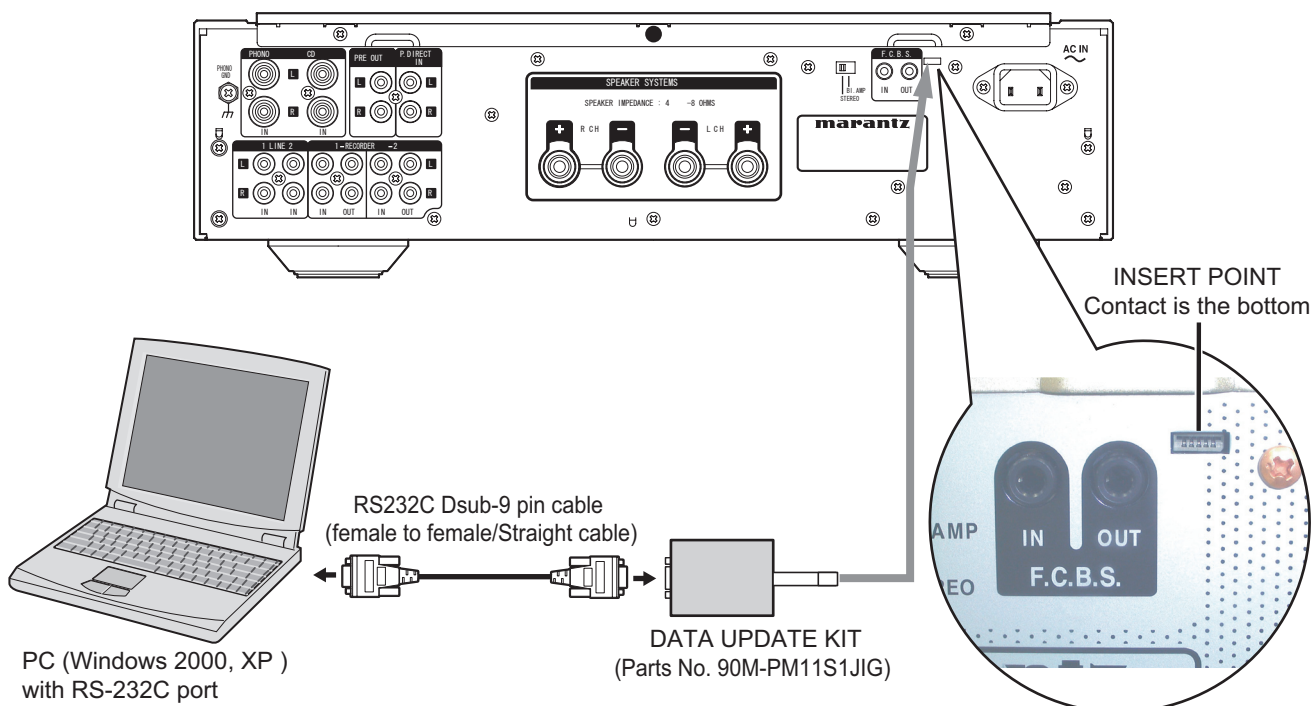

6. MAIN MICROPROCESSOR (QU01) アップデート方法

必要機器

- Windows PC (OS:Windows2000 または WindowsXP) でCOM portのあるもの
- RS232Cストレートケーブル (9pinメス-9pinメス)
- マイコンアップデートディスク (90M-PM15S2CDR)
- マイコンアップデートキット (部品番号 : 90M-PM11S1JIG)

6.1. 接続図

6.2. Installs of The software (Flash Development Toolkit 3.0)

The explanation drawing

- The explanation drawings are using **PM-11S1** in this section. Please replace with **PM-KI-PEARL / PM-13S2** the portion currently mentioned as **PM-11S1**, and operate it.
1. Open the CD-ROM (90M-PM15S2CDR) Disc, and double click soft folder.

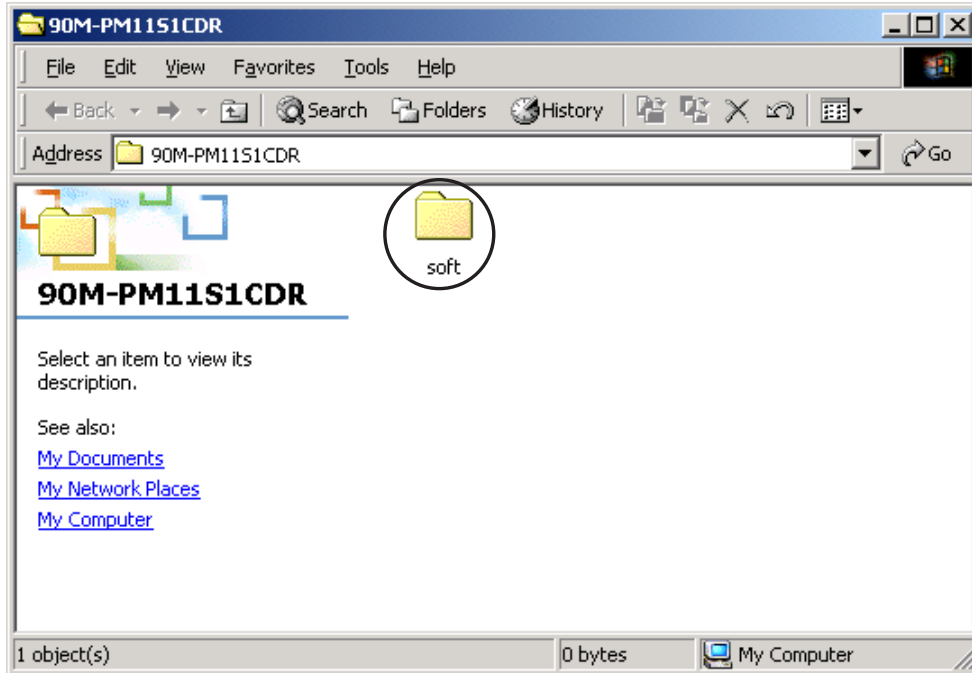

2. Double click the **FDT setup.exe**.

6.2. 書き込みソフトウェアのインストール (Flash Development Toolkit 3.0)

説明図について

- 説明図はPM-11S1を使用しています。図中にPM-11S1と記載されている箇所はPM-KI-PEARL / PM-13S2と置き換えて操作してください。
1. CD-ROM (90M-PM15S2CDR) の soft フォルダをダブルクリックします。

2. **FDT setup.exe** をダブルクリックします。

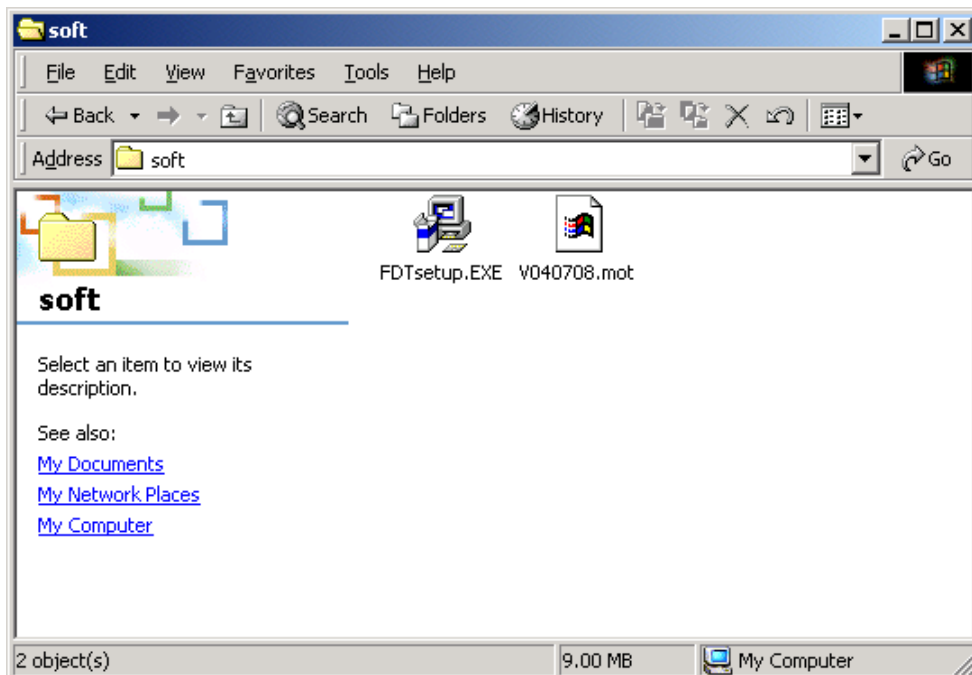

3. Click **Next**.

3. インストールウィザードが起動します。**Next**をクリックします。



4. Choose the language. And click **Next**.

4. 言語を選んで**Next**をクリックします。



5. Click **Yes**.

5. **Yes**をクリックします。

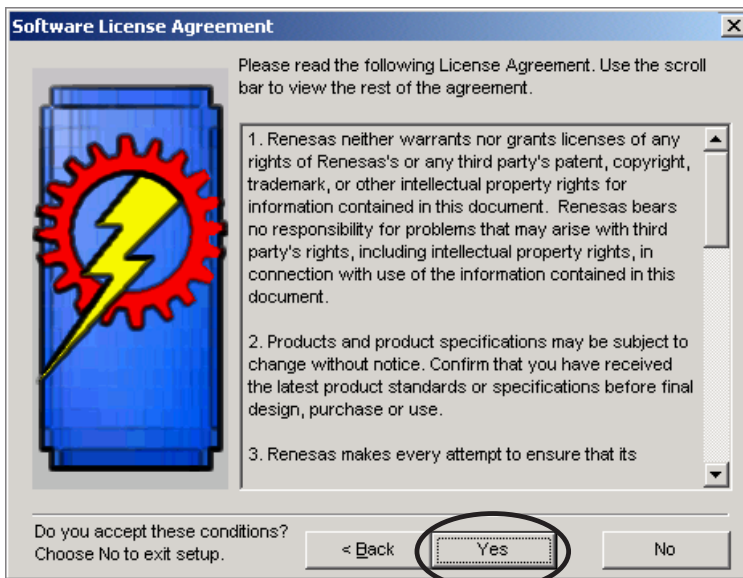

6. Check to the all check boxes. And click **Next**.

6. チェックボックス全てにチェックが入っていることを確認して **Next** をクリックします。

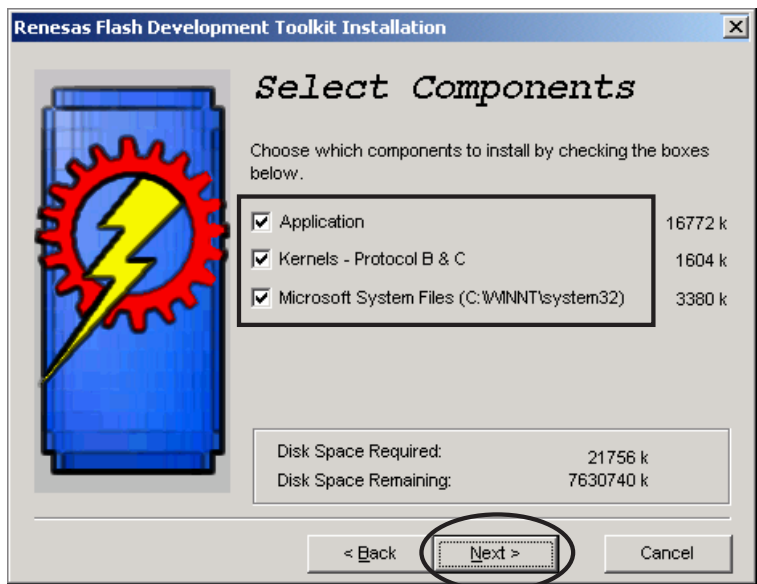

7. Click **Next**.

7. **Next** をクリックします。



8. Check to the all check boxes. And click **Next**.

8. チェックボックス全てにチェックが入っていることを確認して **Next** をクリックします。

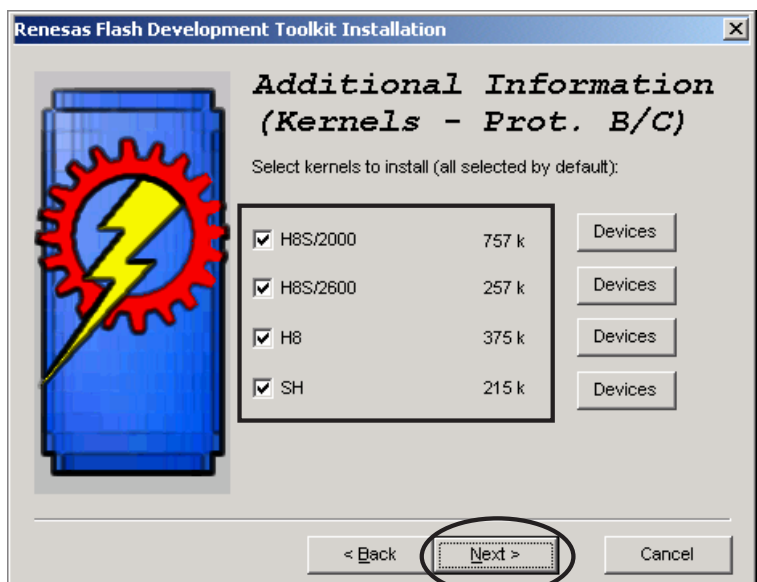

9. Click **Next**.

9. **Next**をクリックします。

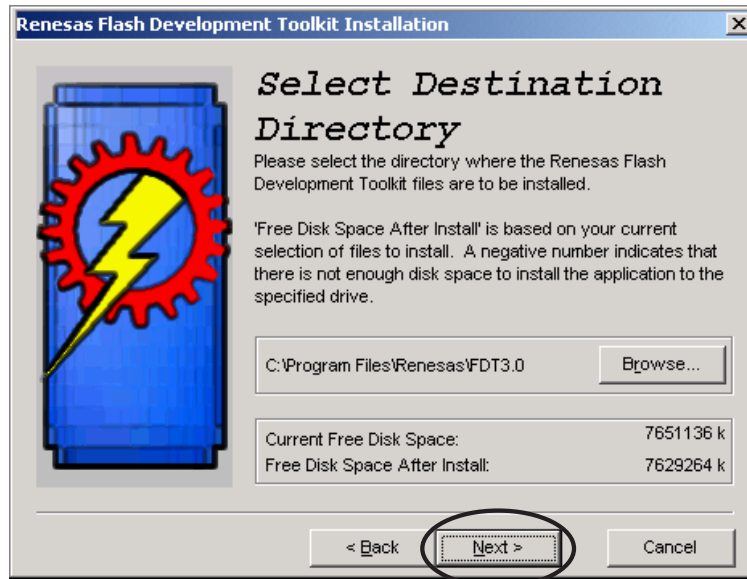

10. Click **Next**.

10. **Next**をクリックします。



11. Click **Next**.

11. **Next**をクリックします。

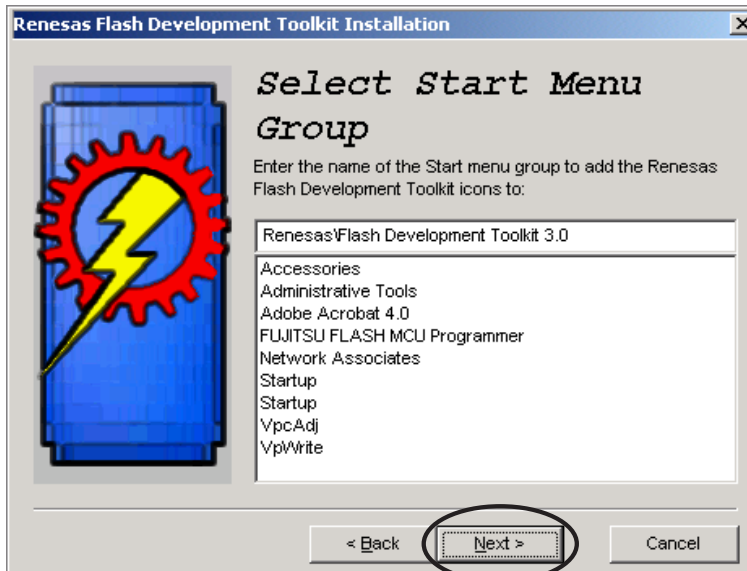

12. Click **Install**.

12. **Install**をクリックします。



13. The status bar appears.

13. インストールを開始します。

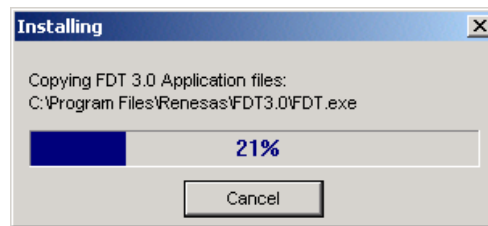

14. Click **Finish**.

14. **Finish**をクリックして書き込みソフトウェアのインストールを完了します。



6.3. The writing software setup procedure.

6.3. 書き込みソフトウェアの設定

Launch up the writing software.

ソフトウェアの起動

1. Click **Start / Programs / Renesas / Flash Development Toolkit 3.0 / Flash Development Toolkit 3.0**.

1. **Start / Programs / Renesas / Flash Development Toolkit 3.0 / Flash Development Toolkit 3.0** をクリックします。

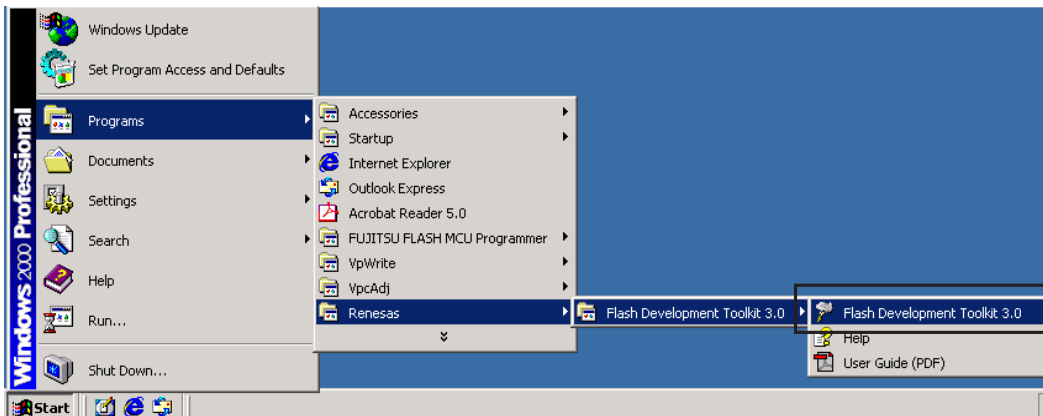

2. Click **OK**. (This window appears at every starting.)

2. **OK** をクリックします。(起動のたびに下記のコマンドが出ますのでその都度 **OK** をクリックしてください。)



3. Check **Create a new project workspace**, and click **OK**.

3. **Create a new project workspace**にチェックを入れ、**OK**をクリックします。

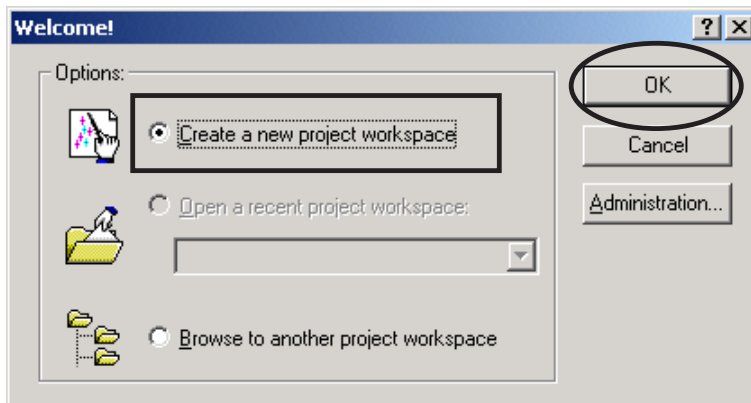

4. **PM-15** is inputted into the Workspace name.
(It is simultaneously inputted into Project Name.)
Click **OK**.

4. Workspace Nameに**PM-15**と入力します。
(同時に Project Name にも入力されます。)
OKをクリックします。

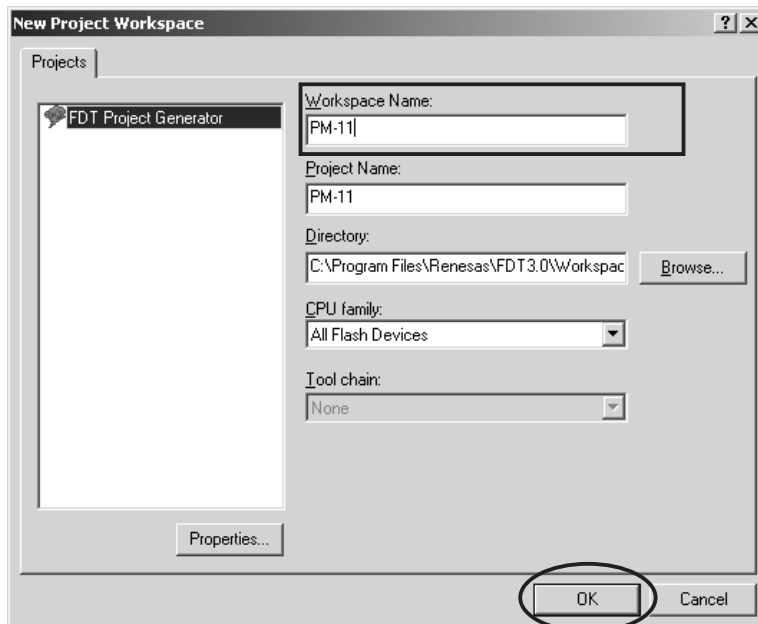

5. Choose the **H8/3687F** in Select Device.
Click **Next**.

5. Select Deviceから**H8/3687F**を選び、クリックします。
Nextをクリックします。

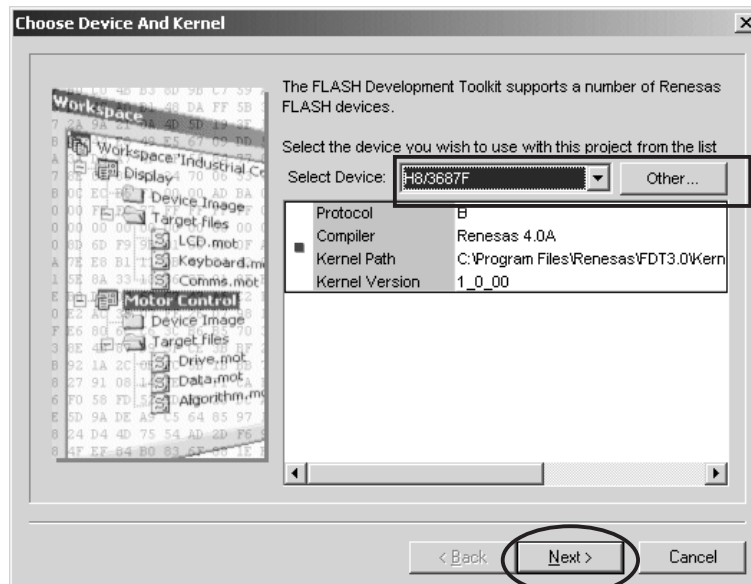

6. Choose the **Serial port No.** in the Select Port. Click **Next**.

6. Select Portから接続する**Serial Port**番号を選び、クリックします。**Next**をクリックします。

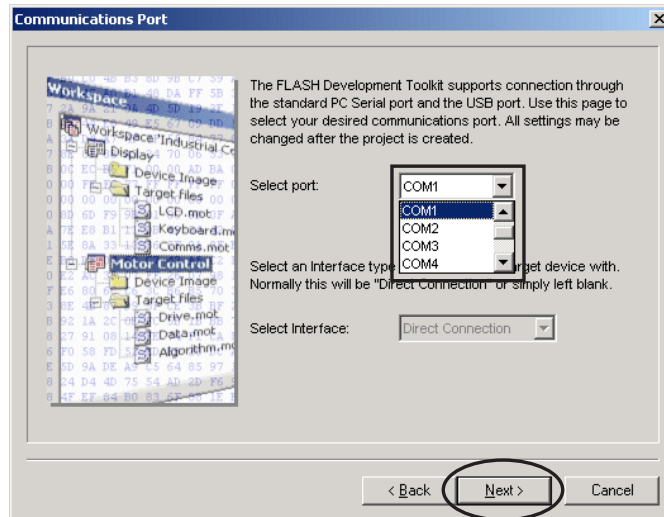

7. **8.0** is inputted into the "Enter the CPU crystal frequency for the selected device:". Click **Next**.

7. "Enter the CPU crystal frequency for the selected device:"に**8.0**と入力します。**Next**をクリックします。

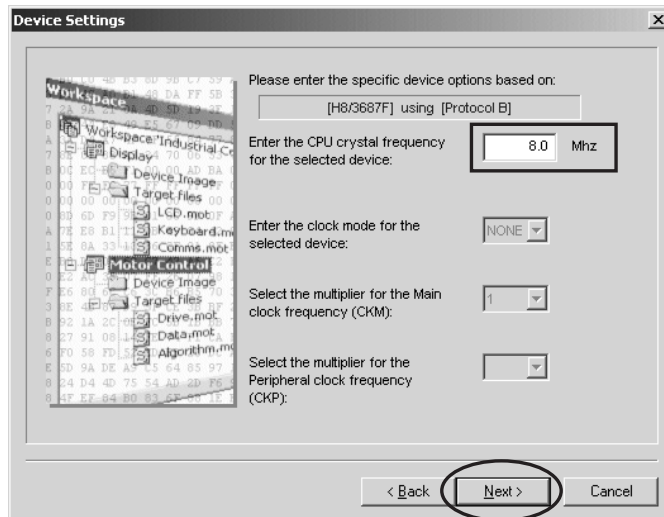

8. Check the **BOOT Mode** in Select Connection. Choose the **19200** in Select Baud rate. Click **Next**.

8. Select Connection: から**BOOT Mode**にチェックを入れます。Select Baud rate: から**19200**を選び、**Next**をクリックします。

Remark :

Please remove check mark, if it is contained in Use Default Baud Rate.

注意 :

Use Default Baud Rate にチェックが入っていると Baud Rate を変更できませんのでチェックを外してください。

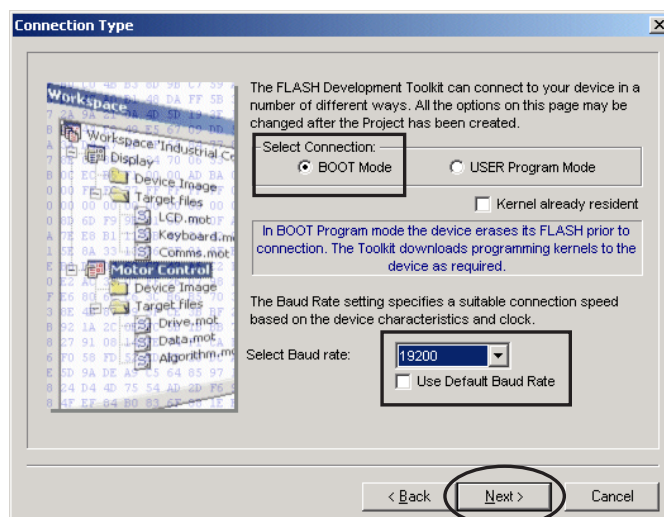

- Check the **Automatic** in Protection.
Check the **Advanced** in Messaging.
Click **Finish**.

- Protection から **Automatic** にチェックを入れます。
Messaging から **Advanced** にチェックを入れます。
Finish をクリックします。

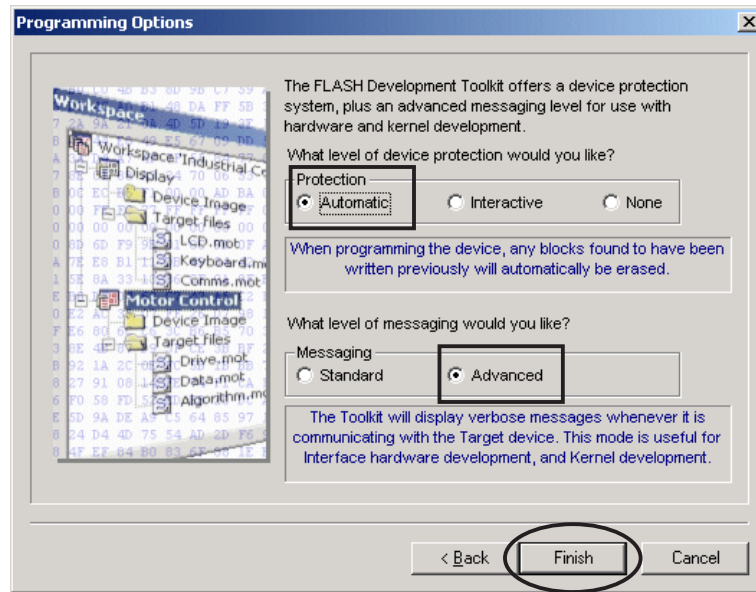

以上で設定は完了です。

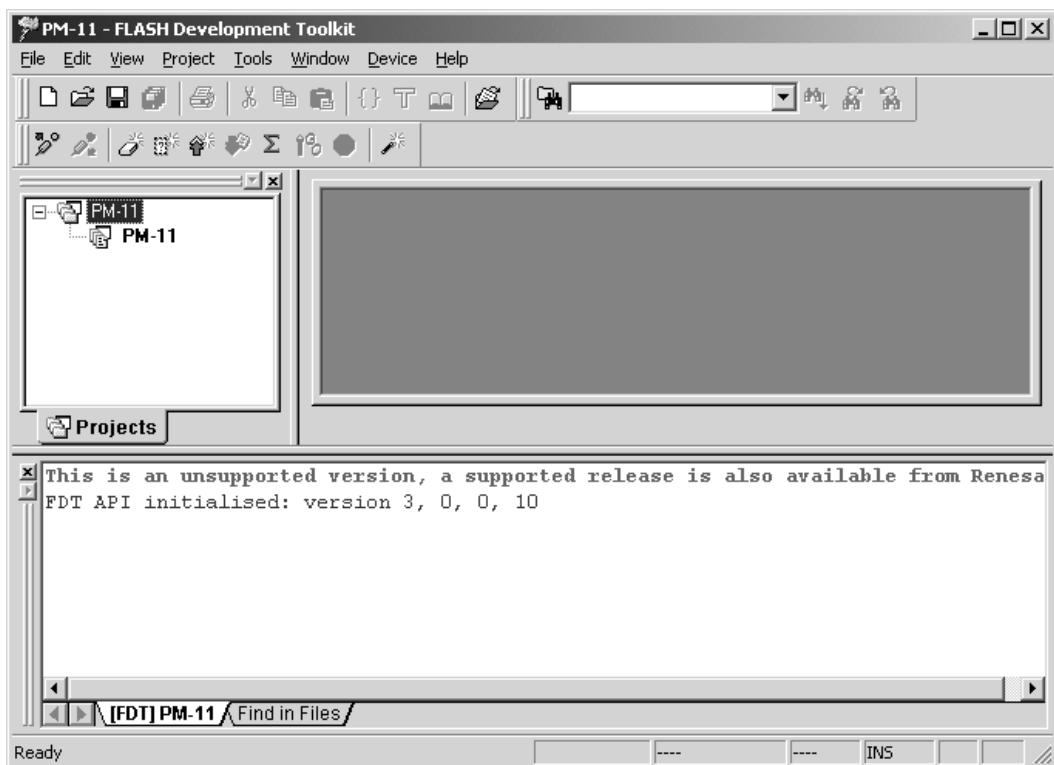

6.4. Writing procedure

1. Click **Start / Programs / Renesas / Flash Development Toolkit3.0 / Flash Development Toolkit3.0**.
2. Click **OK**. (This window appears at every starting)

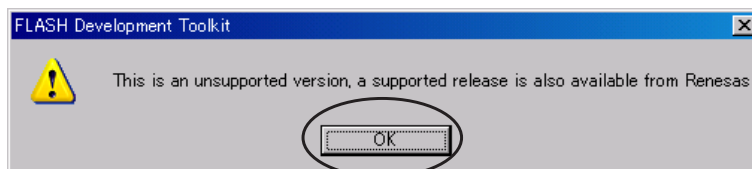

6.4. 書き込み方法

1. **Start / Programs / Renesas / Flash Development Toolkit3.0 / Flash Development Toolkit3.0** をクリックします。
2. **OK** をクリックします。(起動のたびに下記のコメントが出ますのでその都度 **OK** をクリックしてください)

3. Check **Open a recent project workspace**, and click **OK**.

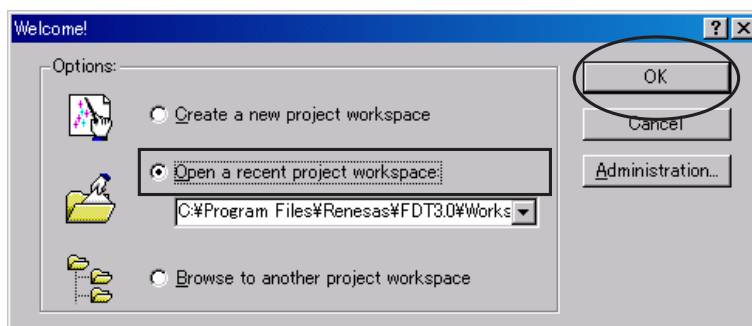

3. **Open a recent project workspace** にチェックを入れて **OK** をクリックします。

4. The right click PM-15, and Click **Add Files...**

4. 以下の画面が出ましたら、2階層目にある PM-15 のアイコン上で右クリックをして、**Add Files...** をクリックします。

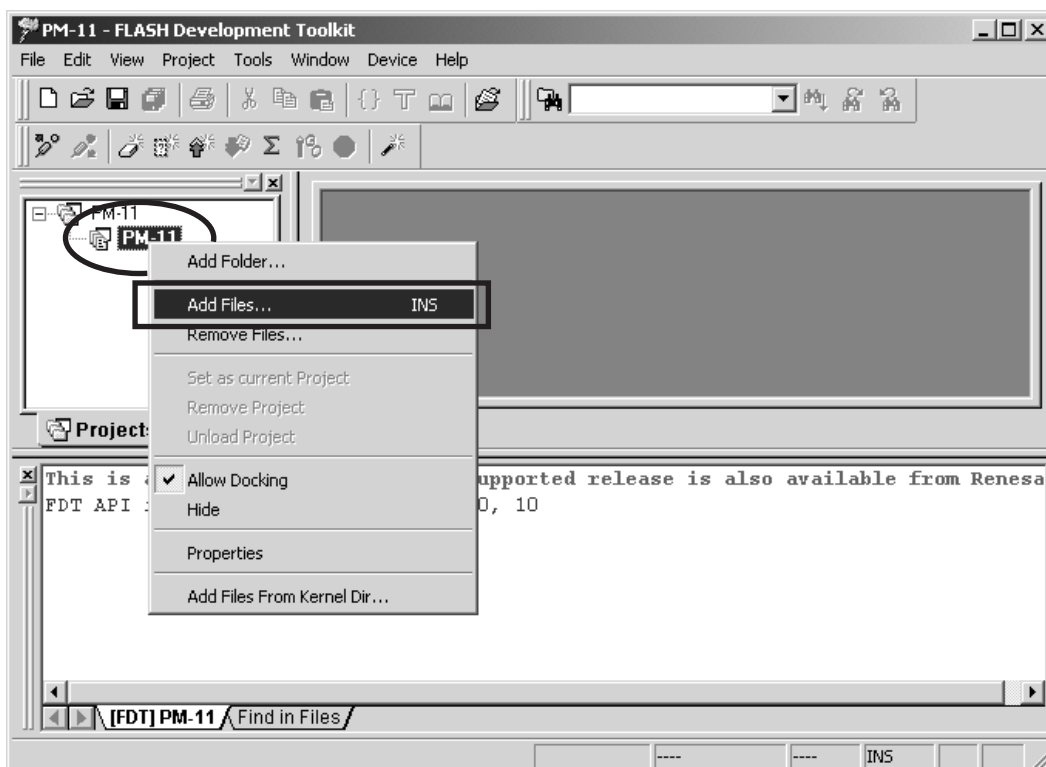

5. Open the CD-ROM (90M-PM15S2CDR) and double click **soft** folder.

5. アップデートディスク (90M-PM15S2CDR) の **soft** フォルダをダブルクリックします。

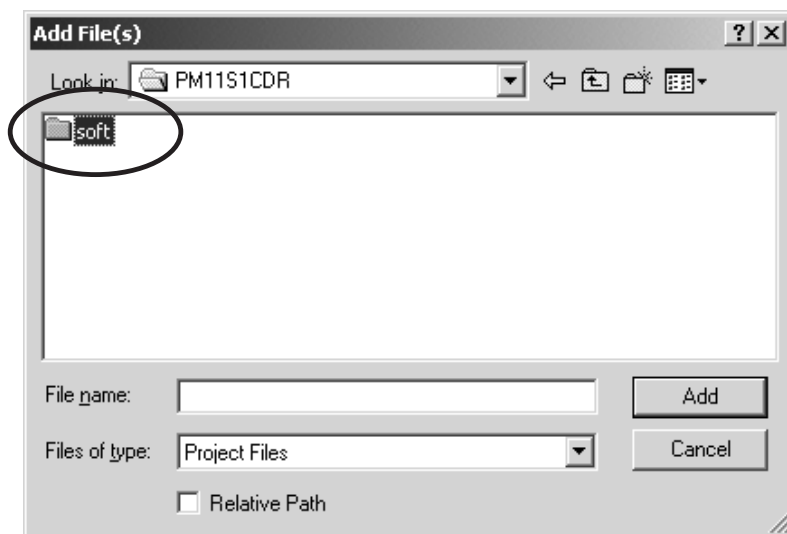

6. Select **V090507.mot**, and Click **Add**.

6. **V090507.mot** を選択し、**Add** をクリックします。

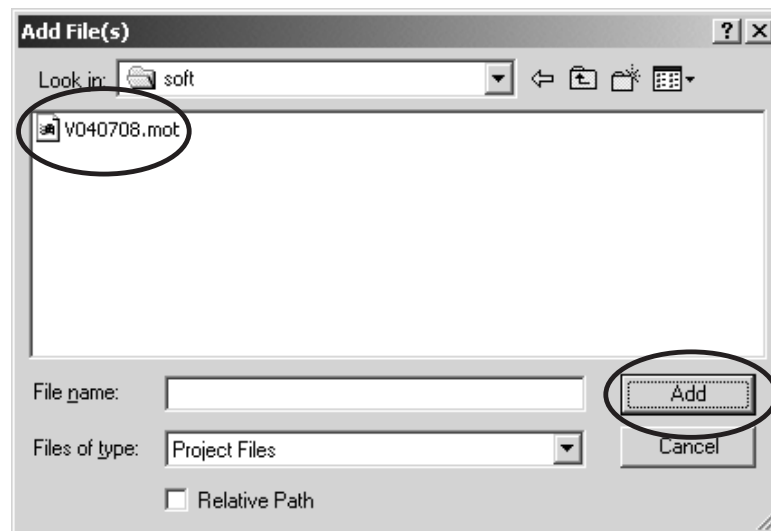

7. The holder of **V090507.mot** is made.

7. **V090507.mot** のホルダーが出来ます。

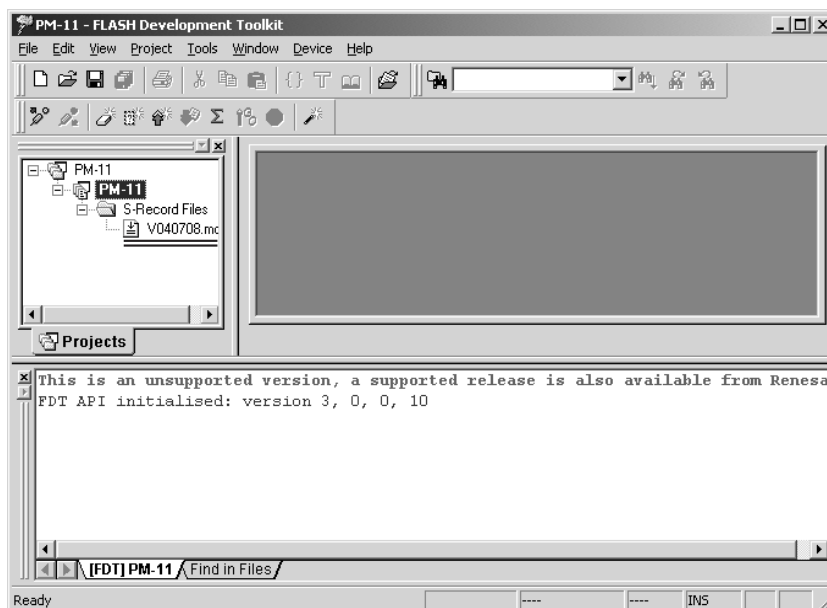

8. It checks that PM-KI-PEARL / PM-13S2 and the COM port are connected by RS232C cable.
9. Press **POWER** Button to turn on the unit.
The unit is in the boot mode.(LED and LCD display on the front panel disappear.)
- 10.The right click V090507.mot, and Click **Download File**.

8. PM-KI-PEARL / PM-13S2とWindows PCのCOMポートの接続を確認します。
9. **POWER** ボタンを押し、Power On 状態にします。
(この状態より、書き込みモードですが、前面のLED及びLCD表示は消えます。)
10. 4階層目にある V090507.mot のアイコン上で右クリックをして "**Download File**" をクリックします。

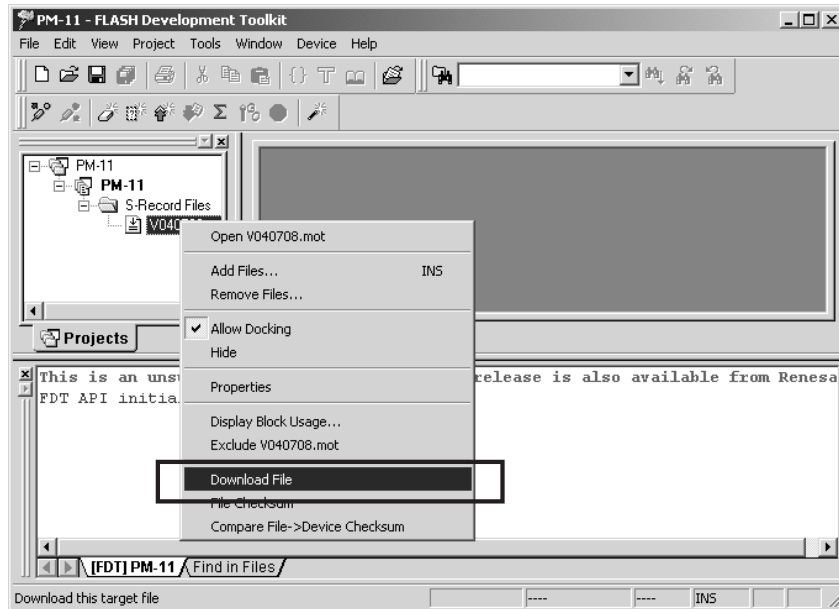

11. The screen becomes the uploading condition.
When writing is Finished, the below message appears on the screen.

11. 書き込みが始まると下のような画面が出て状態を表示します。
書き込みが終わると下のような画面が出ます。

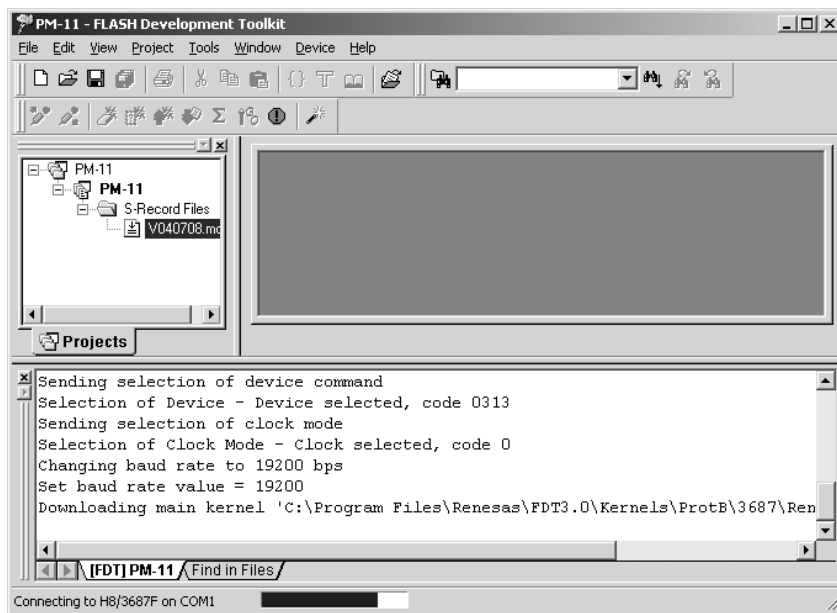

12. The Main microprocessor (QU01) has been Update.

12. 以上で、書き込み作業は終了です。

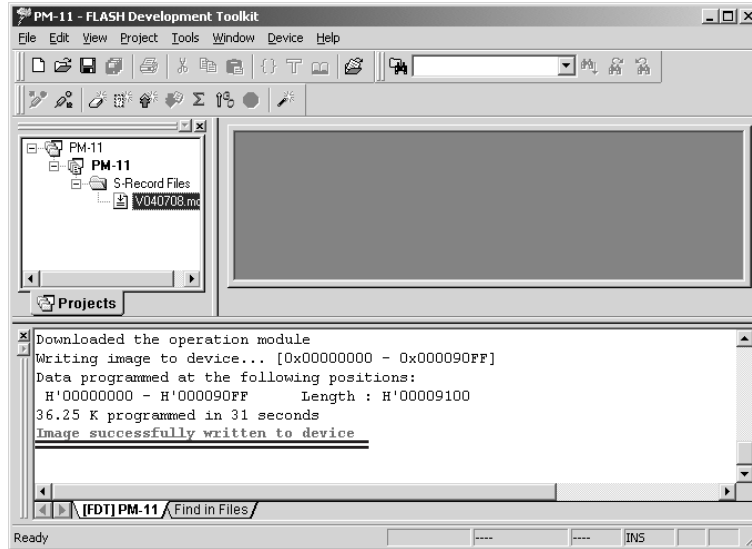

13. Turn off Power switch, then disconnect FFC cable from PM-KI-PEARL / PM-13S2.

13. PM-KI-PEARL / PM-13S2の電源を切り、FFCケーブルを外します。

14. Check the version number of the firmware
Refer to "4. SERVICE MODE" on page 4.

14. VERSIONの確認をします。
4ページの"4. SERVICE MODE"で確認します。
書き込んだバージョンが正しければ書き換え完了です。

7. WIRING DIAGRAM

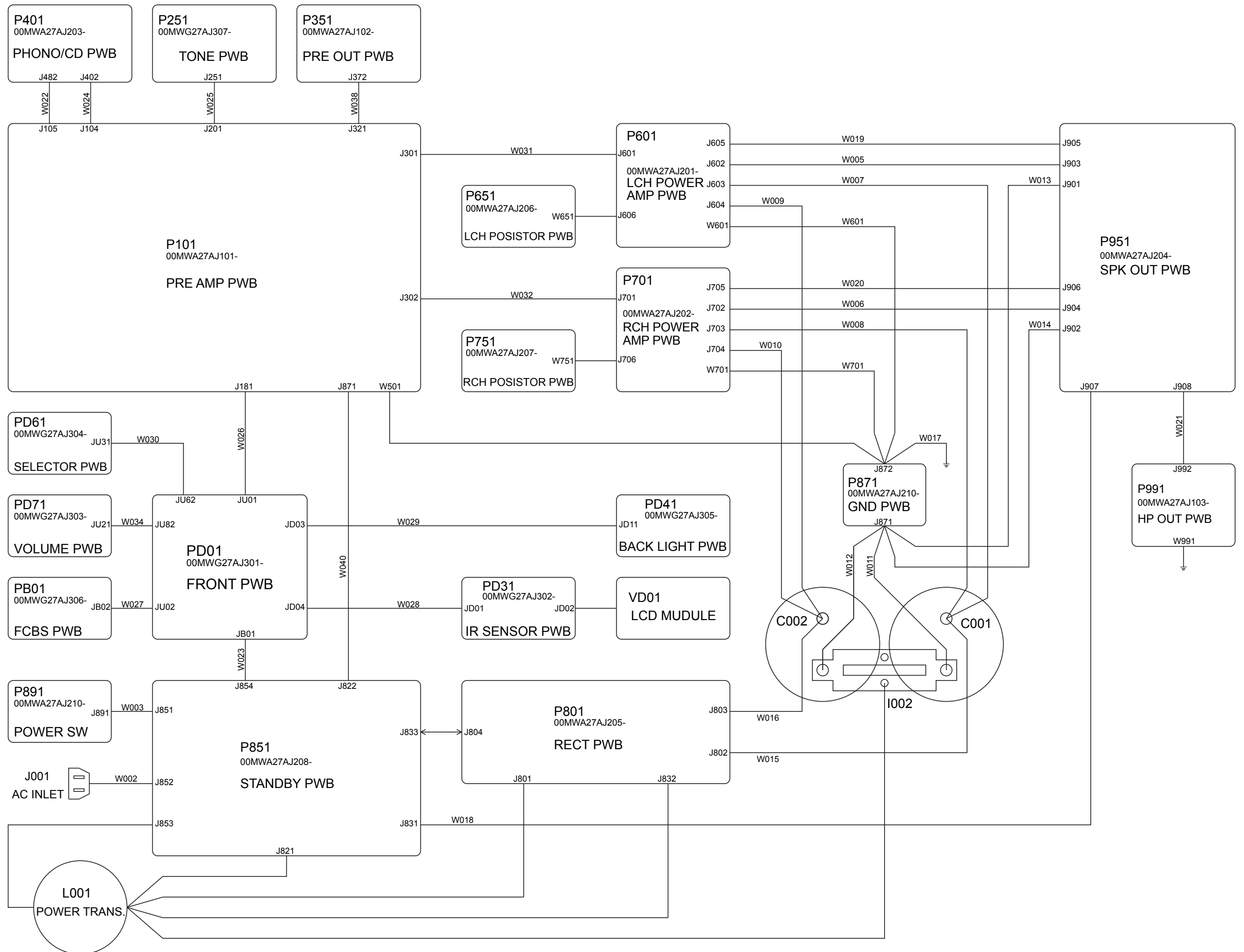

8. BLOCK DIAGRAM

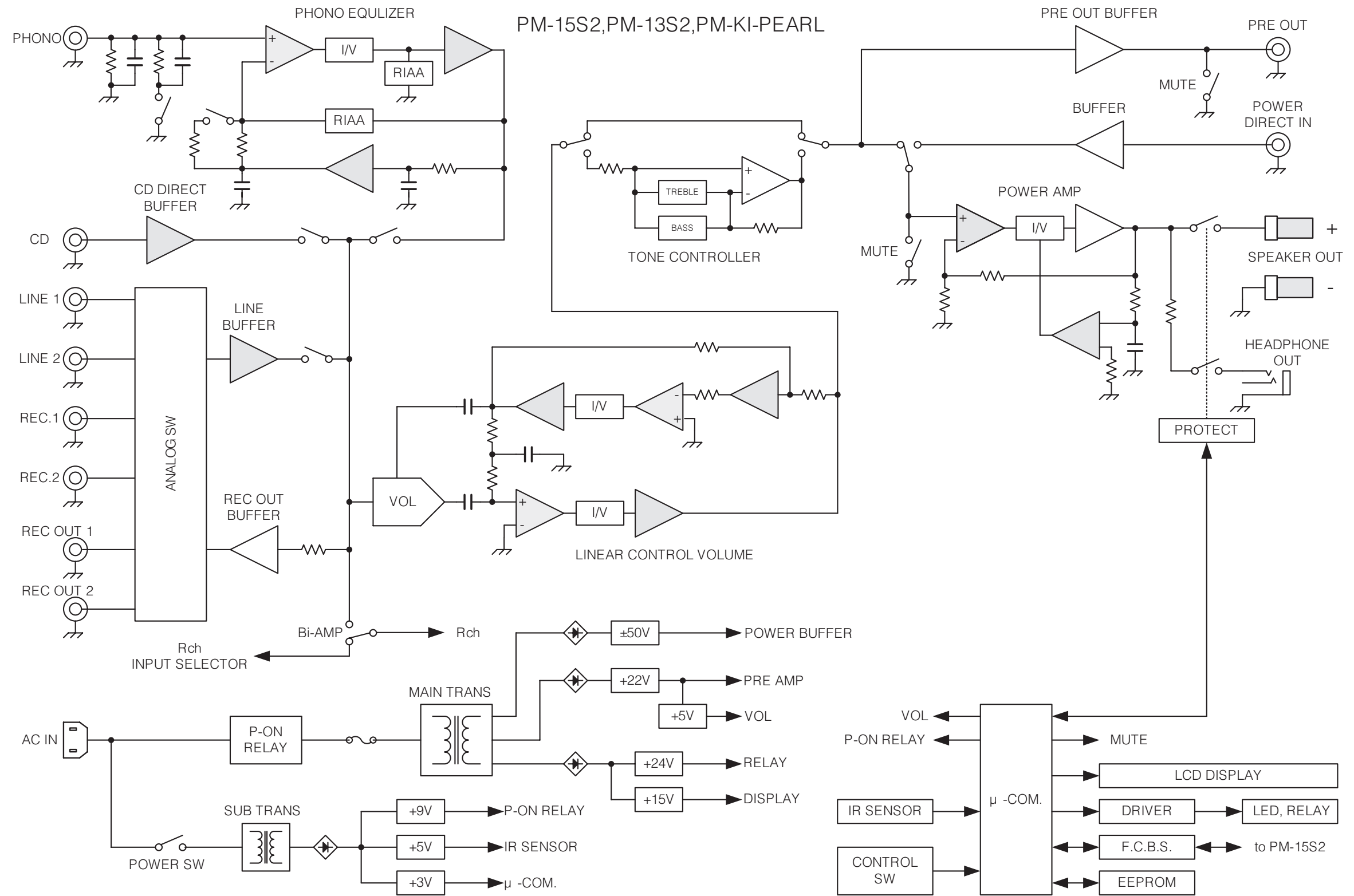

9. SCHEMATIC DIAGRAM

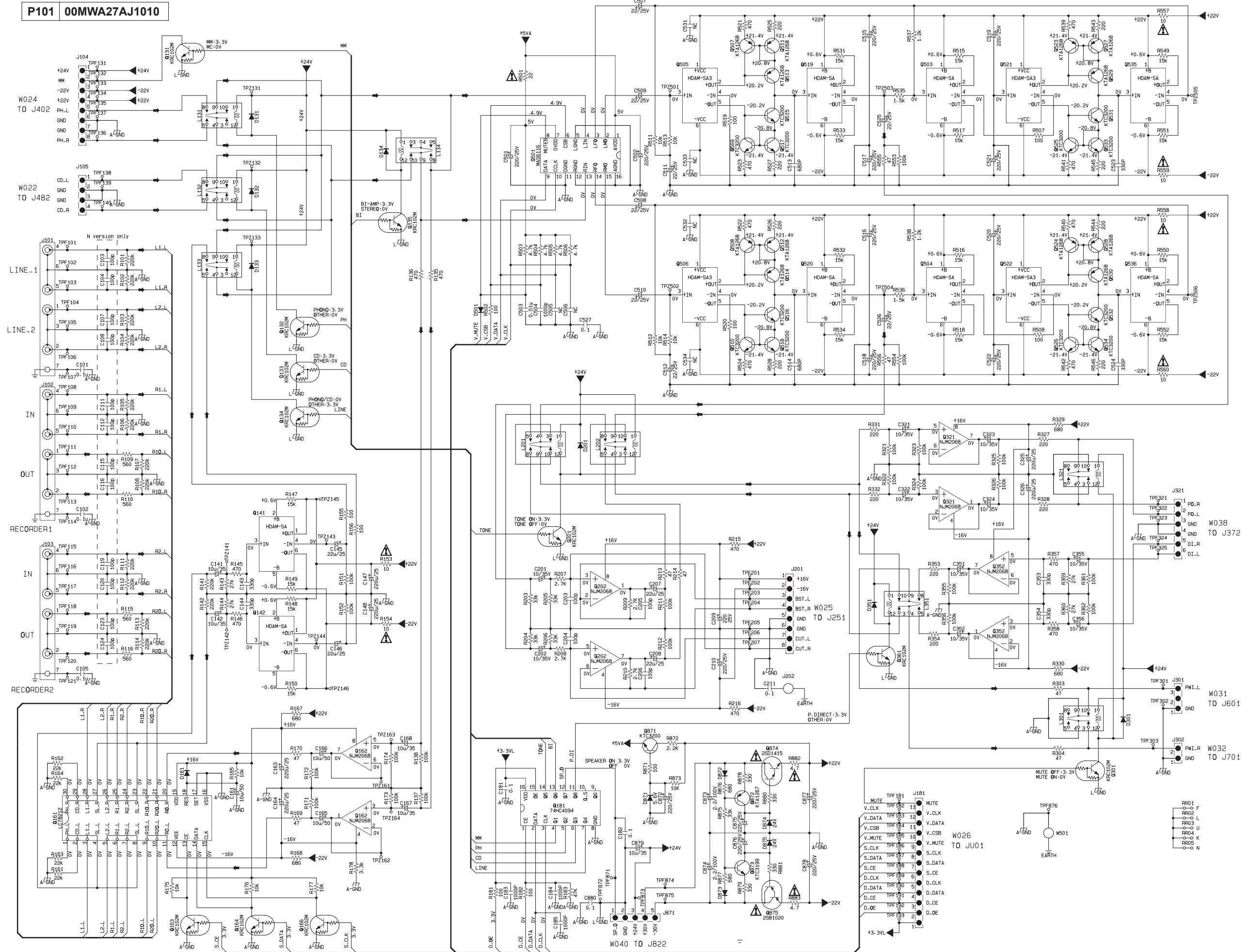

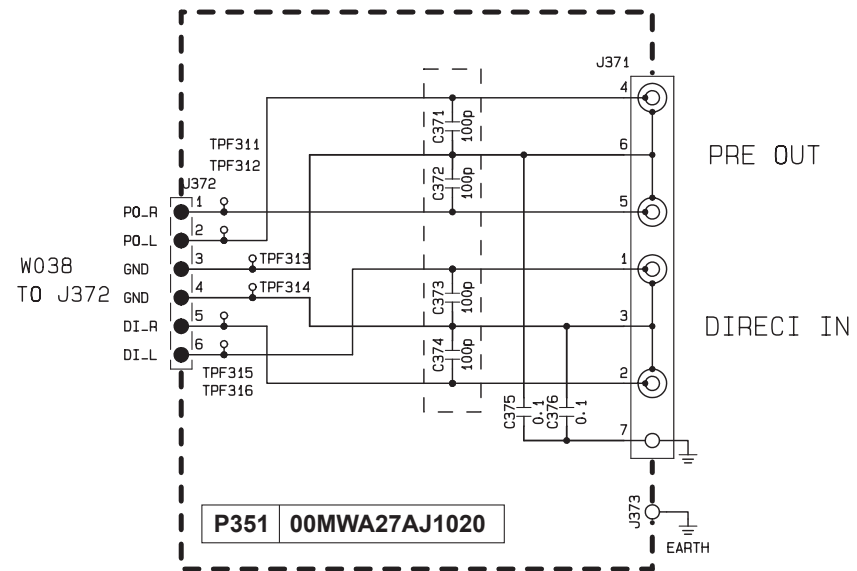

5501 00MVG22AJ5010
HDAM-SA3 MODULE

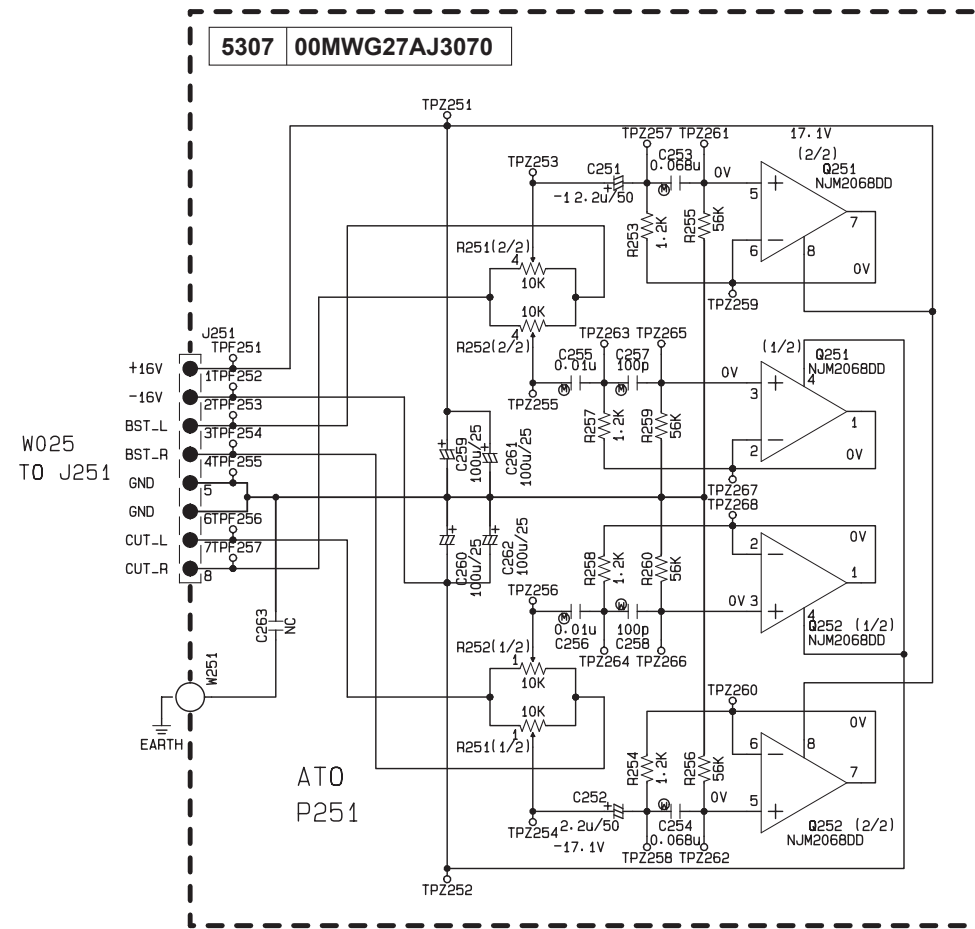
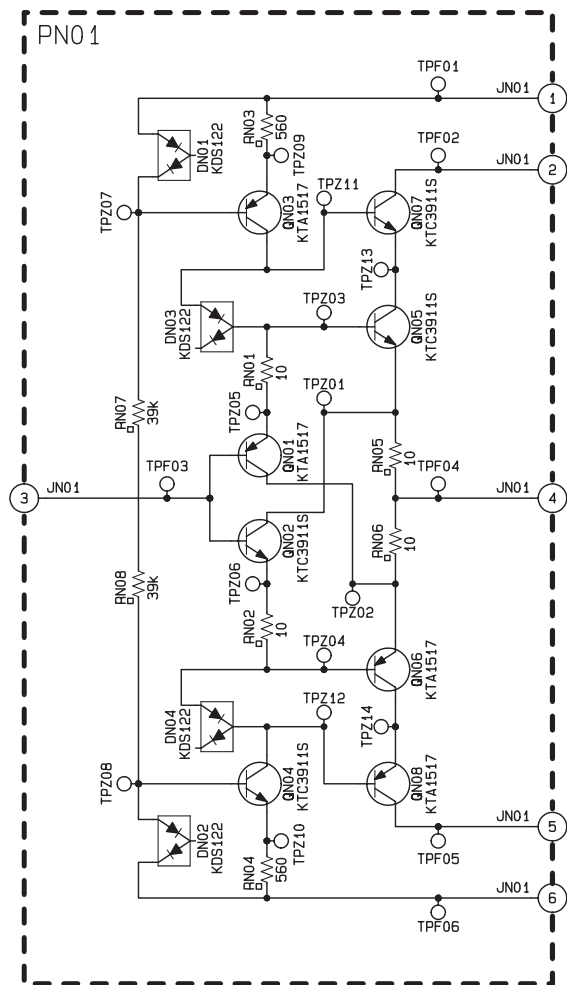

5601 00MWA27AJ6010
HDAM-SA2 MODULE

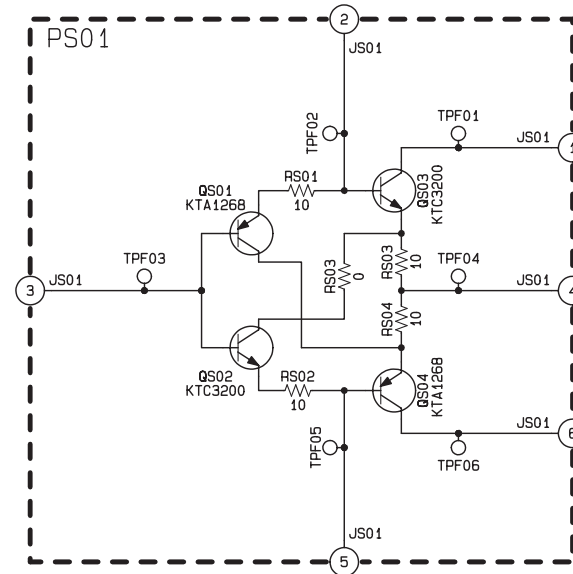

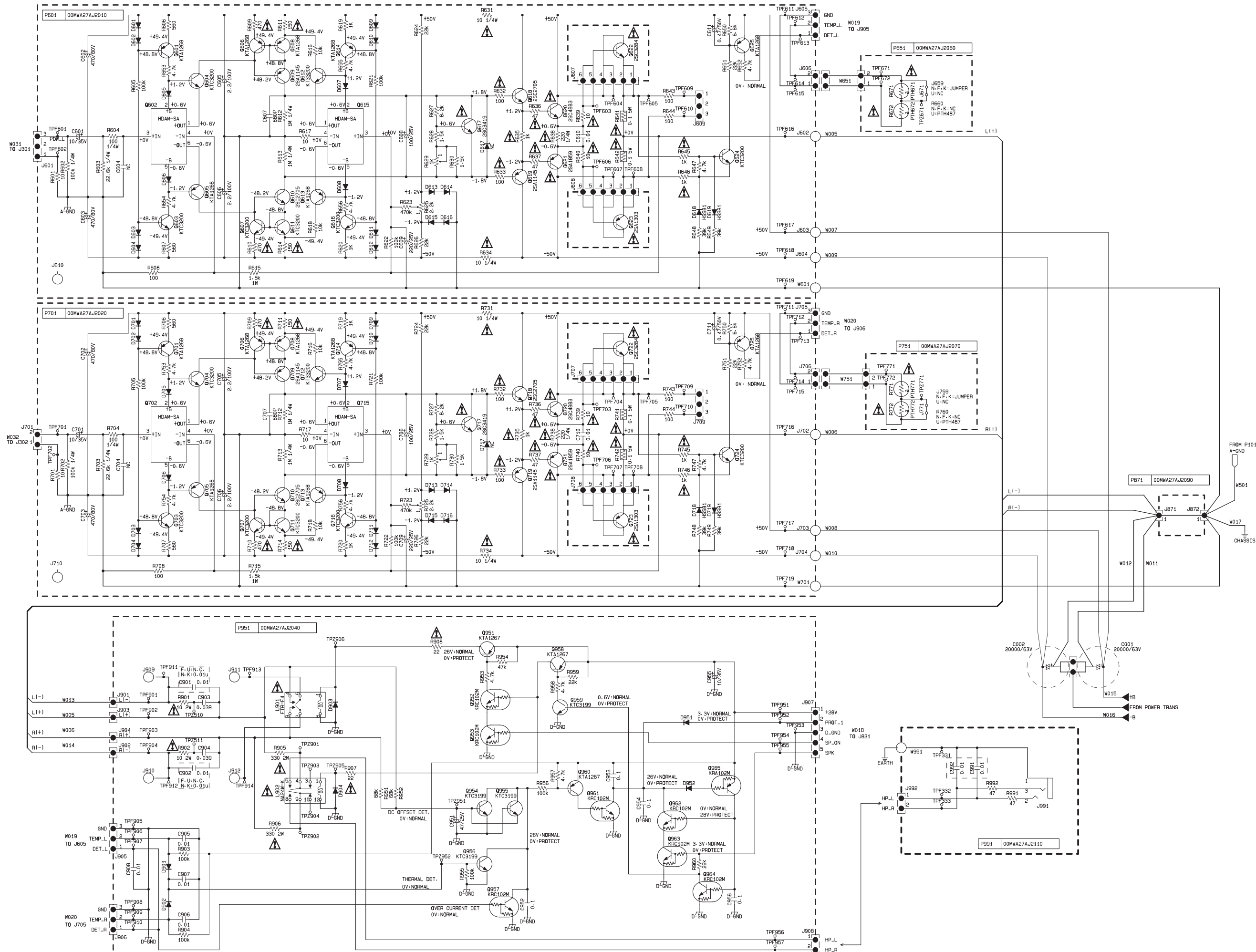

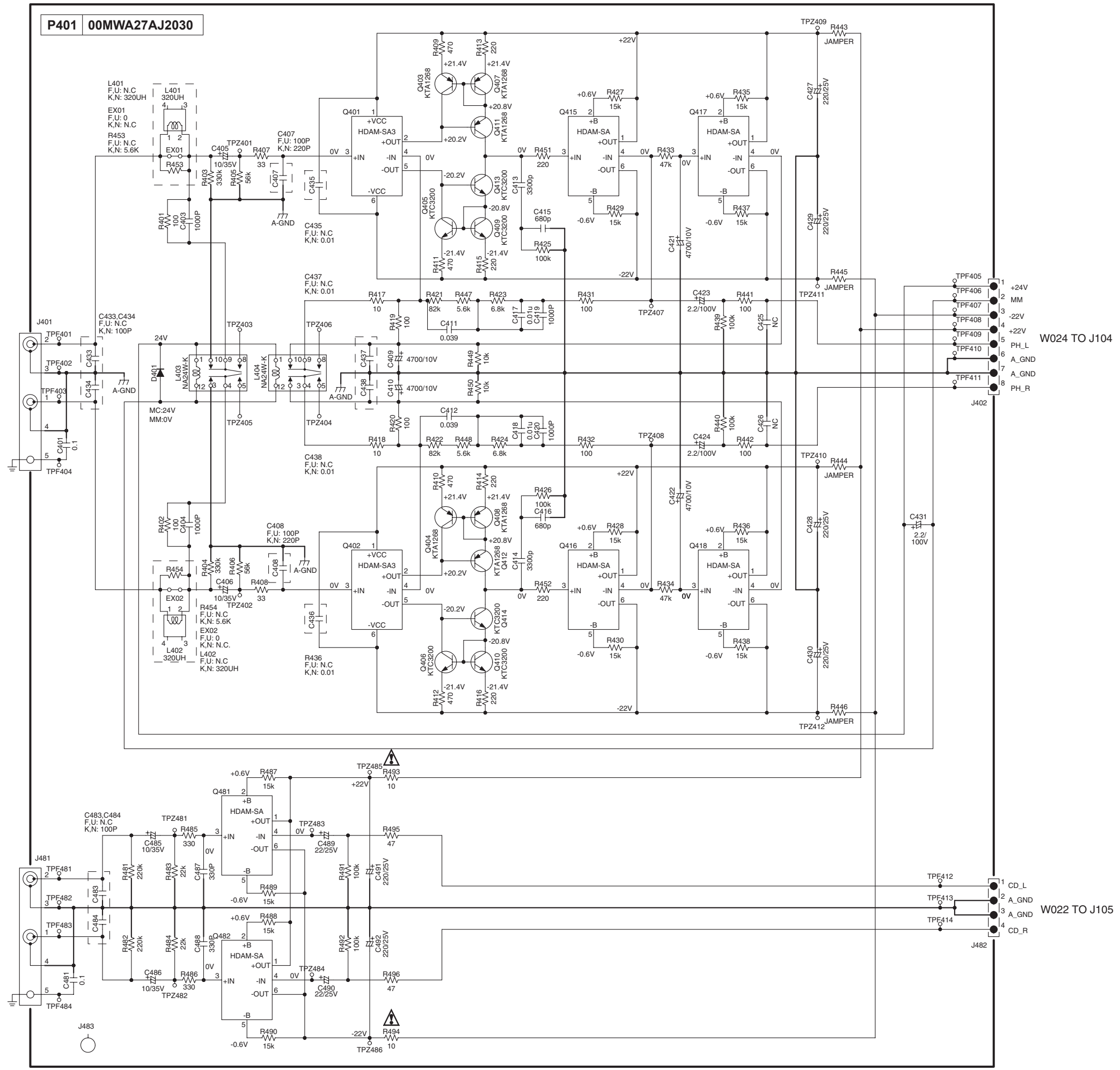

P401 00MWA27AJ2030

W024 TO J104

W022 TO J105

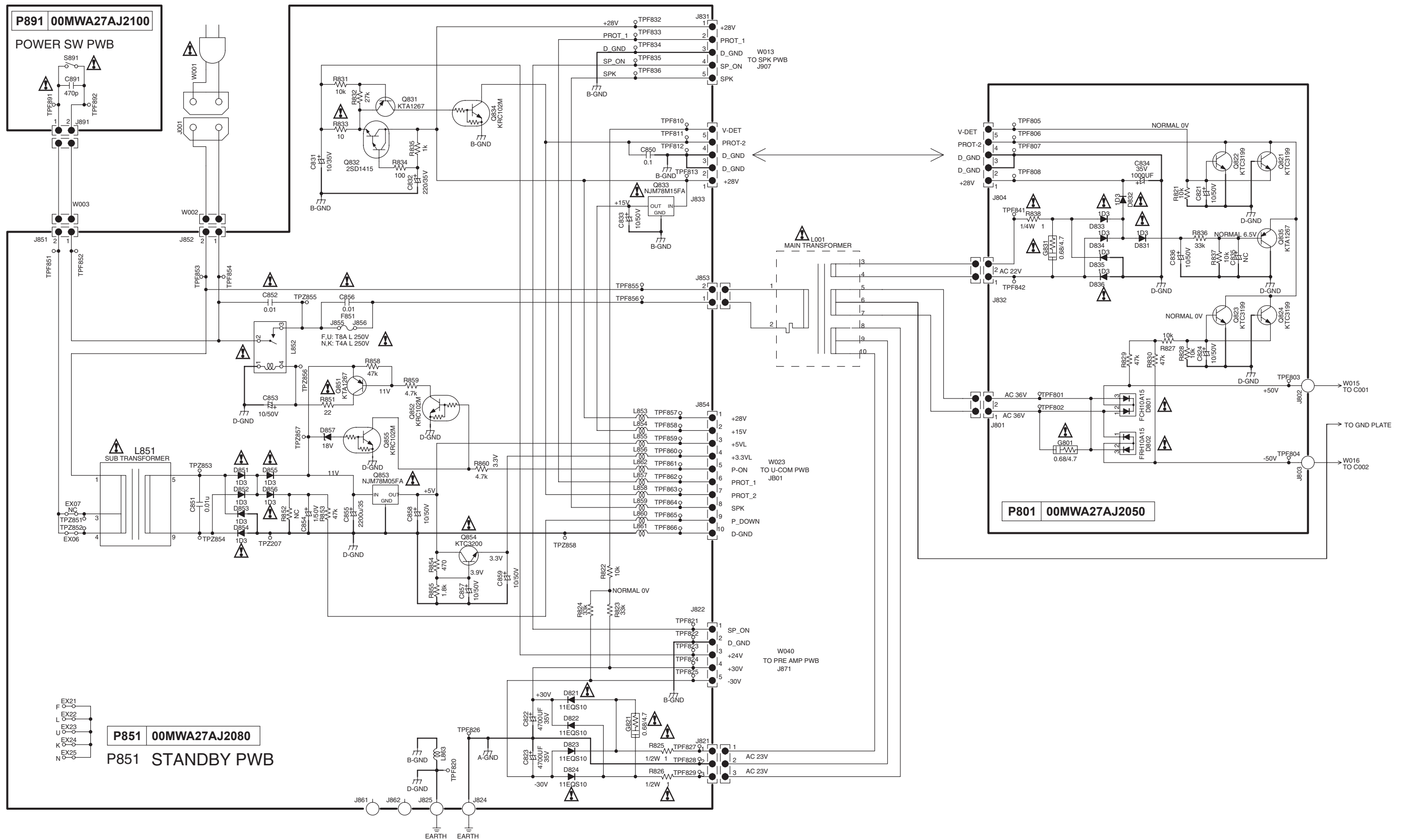

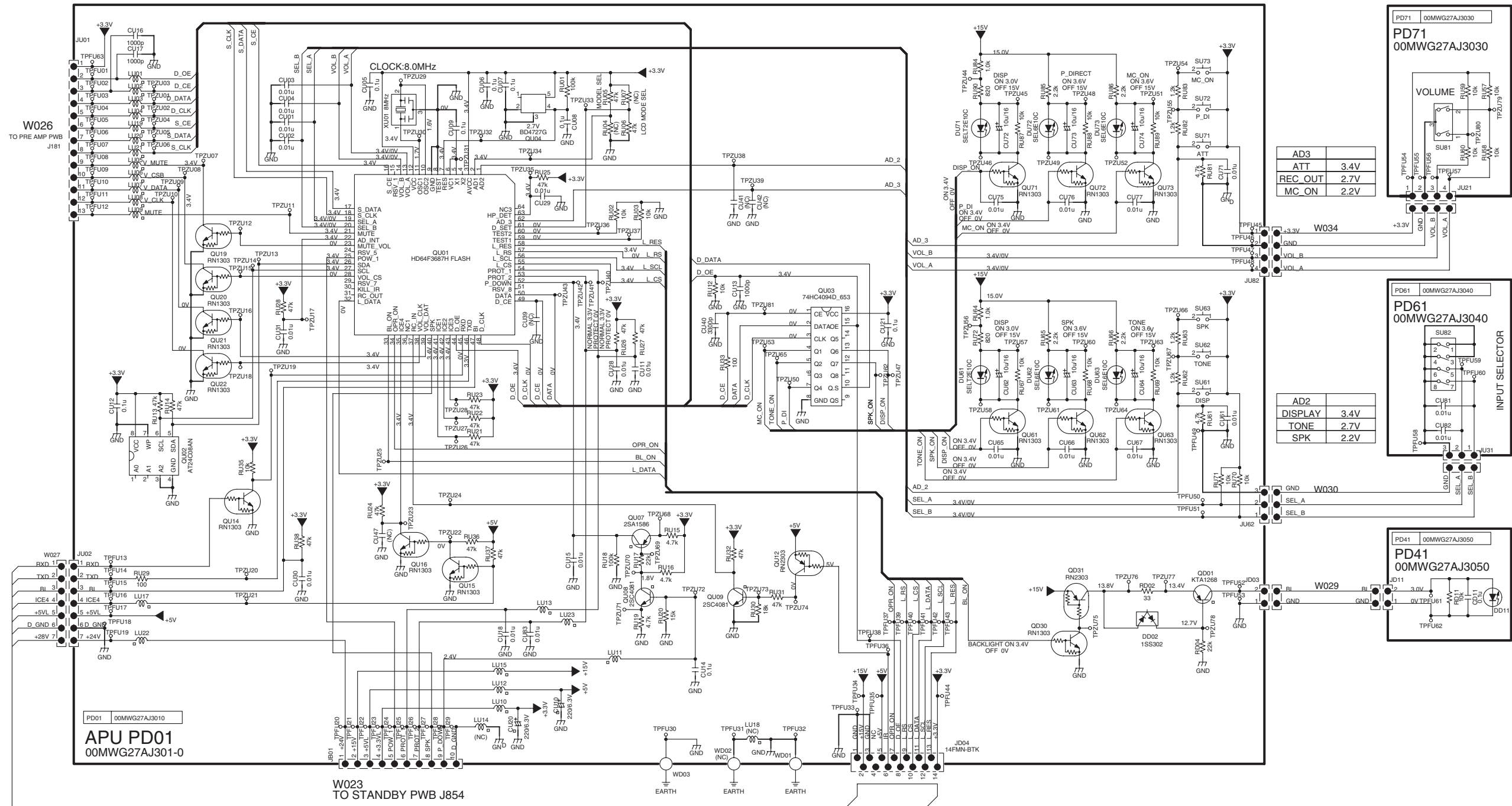

10. PARTS LOCATION

P101 A

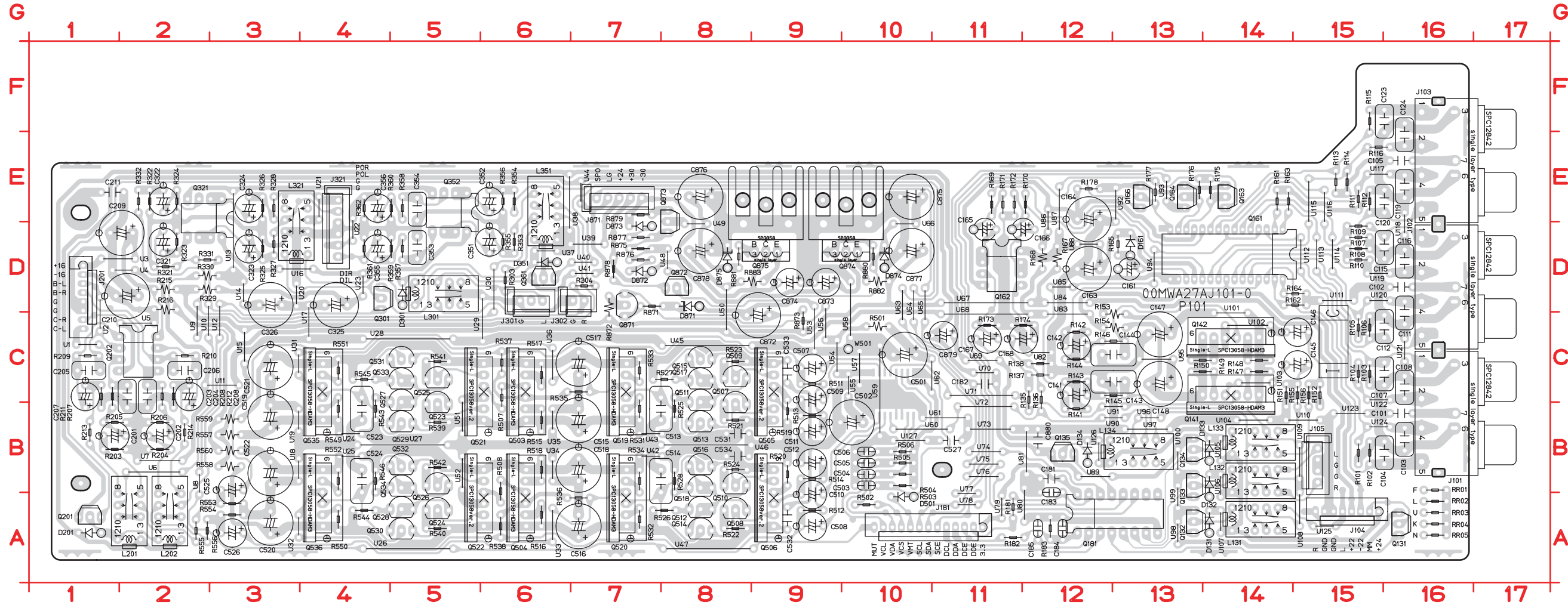

C101	B16	C182	C11	C505	B10	C876	E8	L132	B14	Q507	B8	Q872	D8	R148	C14	R205	B2	R358	E5	R531	B7	R875	D7	U114	D15	U28	C4	U48	D8	U68	C11	U88	D12
C102	D16	C183	B12	C506	B10	C877	D10	L133	B14	Q508	A8	Q873	E8	R149	C14	R206	B2	R359	D5	R532	A7	R876	D7	U115	D15	U29	C6	U49	D8	U69	C11	U89	B12
C103	B16	C184	A12	C507	C9	C878	D8	L134	B12	Q509	C8	Q874	D10	R150	C14	R207	B1	R360	E5	R533	C7	R877	D7	U116	D15	U3	D1	U5	C2	U7	B2	U9	C2
C104	B16	C185	A12	C508	A9	C879	C11	L201	A2	Q510	B8	Q875	D9	R151	B14	R208	B2	R361	D4	R534	B7	R878	D7	U117	E15	U30	D6	U50	C8	U70	C11	U90	B12
C105	E16	C201	B2	C509	C9	C880	B12	L202	A2	Q511	C8	R101	B15	R152	C15	R209	C1	R362	E4	R535	C7	R879	E7	U118	D16	U31	C3	U51	B5	U71	C11	U91	B12
C107	C16	C202	B2	C510	A9	D131	A14	L301	D5	Q512	A8	R102	B15	R153	C13	R210	C2	R501	C10	R536	A7	R880	D10	U119	D15	U32	A3	U52	B5	U72	B11	U92	E13
C108	C16	C203	B2	C511	B9	D132	A14	L321	D4	Q513	B8	R103	C15	R154	C13	R211	B1	R502	A10	R537	C6	R881	D8	U12	C3	U33	A6	U53	C9	U73	B11	U93	E13
C111	C16	C204	C2	C512	B9	D133	B14	L351	D6	Q514	A8	R104	C15	R155	C15	R212	C2	R503	B10	R538	A6	R882	D10	U120	D15	U34	B6	U54	C9	U74	B11	U94	D13
C112	C16	C205	C1	C513	B8	D134	B12	Q131	A16	Q515	C8	R105	C15	R156	C15	R213	B1	R504	B10	R539	B5	R883	D9	U121	C16	U35	B6	U55	C10	U75	B11	U95	C13
C115	D16	C206	C2	C514	B8	D161	D13	Q132	A13	Q516	B8	R106	C15	R161	E14	R214	B2	R505	B10	R540	A5	RR01	B16	U122	C15	U36	C6	U56	C9	U76	B11	U96	B13
C116	D16	C207	B1	C515	B7	D201	A1	Q133	B13	Q517	C8	R107	D15	R162	D15	R215	D2	R506	B10	R541	C5	RR02	A16	U123	B15	U37	D6	U57	C10	U77	A11	U97	B13
C119	E16	C208	B2	C516	A7	D301	D5	Q134	B13	Q518	B8	R108	D15	R163	E14	R216	D2	R507	C6	R542	B5	RR03	A16	U124	B15	U38	D6	U58	C10	U78	A11	U98	A13
C120	E16	C209	D2	C517	C7	D351	D6	Q135	B12	Q519	C7	R109	D15	R164	D15	R303	D6	R508	B6	R543	C4	RR04	A16	U125	A15	U39	D7	U59	B10	U79	A11	U99	A13
C123	E16	C210	D2	C518	B7	D501	A10	Q141	C14	Q520	A7	R110	D15	R165	D13	R304	D7	R511	C9	R544	A4	RR05	A16	U126	B12	U4	D1	U6	B2	U8	A2	W501	C10
C124	E16	C211	E2	C519	B3	D871	D8	Q142	C14	Q521	C6	R111	E15	R167	D12	R321	D2	R512	A9	R545	C4	U1	C1	U127	B10	U40	D7	U60	B10	U80	A12		
C141	C12	C321	D2	C520	A3	D872	D7	Q161	D14	Q522	A6	R112	E15	R168	D12	R322	E2	R513	B9	R546	B4	U10	C2	U13	D3	U41	D7	U61	B10	U81	B12		
C142	C12	C322	E2	C521	C3	D873	D7	Q162	D11	Q523	B5	R113	E15	R169	E11	R323	D2	R514	B9	R549	B4	U100	B13	U14	D3	U42	B7	U62	C11	U82	C12		
C143	C12	C323	D3	C522	B3	D874	D10	Q163	E14	Q524	A5	R114	E15	R170	E12	R324	E2	R515	B6	R550	A4	U101	C14	U15	C3	U43	B7	U63	C10	U83	C12		
C144	C13	C324	E3	C523	B4	D875	D8	Q164	E13	Q525	C5	R115	F15	R171	E11	R325	D3	R516	A6	R551	C4	U102	C14	U16	D3	U44	E7	U64	C10	U84	D12		
C145	C15	C325	D4	C524	B4	J101	B17	Q166	E13	Q526	B5	R116	E16	R172	E11	R326	E3	R517	C6	R552	B4	U103	C14	U17	C4	U45	C8	U65	C10	U85	D12		
C146	C15	C326	D3	C525	B3	J102	D17	Q181	A12	Q527	C5	R135	C12	R173	C11	R327	D3	R518	B6	R553	A3	U104	B14	U18	B3	U46	B8	U66	D10	U86	D12		
C147	C13	C351	D6	C526	A3	J103	E17	Q201	A1	Q528	A5	R136	C12	R174	C11	R328	E3	R519	B9	R554	A3	U105	B14	U19	B3	U47	A8	U67	D11	U87	D12		
C148	C13	C352	E6	C527	B11	J104	A15	Q202	C2	Q529	B5	R137	C12	R175	E14	R329	D3	R520	B9	R555	A2	U106	A14	U2	C1								
C161	D13	C353	D5	C531	B8	J105	B15	Q301	D4	Q530	A5	R138	C12	R176	E13	R330	D3	R521	B8	R556	A2	U107	A14	U20	D3								
C163	D12	C354	E5	C532	A9	J181	A11	Q321	E3	Q531	C5	R141	B12	R177	E13	R331	D3	R522	A8	R557	B3	U108	A15	U21	E4								
C164	E12	C355	D4	C533	C9	J201	D1	Q352	E5	Q532	B5	R142	C12	R178	E12	R332	E2	R523	C8	R558	B3	U109	B15	U22	D4								
C165	D11	C356	E4	C534	B8	J301	D6	Q361	D6	Q533	C5	R143	C12	R181	A11	R353	D6	R524	B8	R559	B3	U11	C2	U23	D4								
C166	D12	C501	C10	C872	C9	J302	D7	Q503	C6	Q534	B5	R144	C12	R182	A11	R354	E6	R525	C8	R560	B3	U110	B14	U24	B4								
C167	C11	C502	B10	C873	D9	J321	E4	Q504	A6	Q535	C4	R145	C12	R183	A12	R355	D6	R526	A8	R871	D7	U111	D15	U25	B4								
C168	C12	C503	B10	C874	D9	J871	E7	Q505	C9	Q536	A4	R146	C12	R203	B2	R356	E6	R527	C7	R872	C7	U112	D15	U26	A4								
C181	B12	C504	B10	C875	E10	L131	A14	Q506	A9	Q871	D7	R147	C14	R204	B2	R357	D5	R528	B8	R873	C9	U113	D15	U27	B4								

鉛フリー半田
半田付けには、鉛フリー半田 (Sn-Ag-Cu) を使用してください。
Lead-free Solder
When soldering, use the Lead-free Solder (Sn-Ag-Cu).

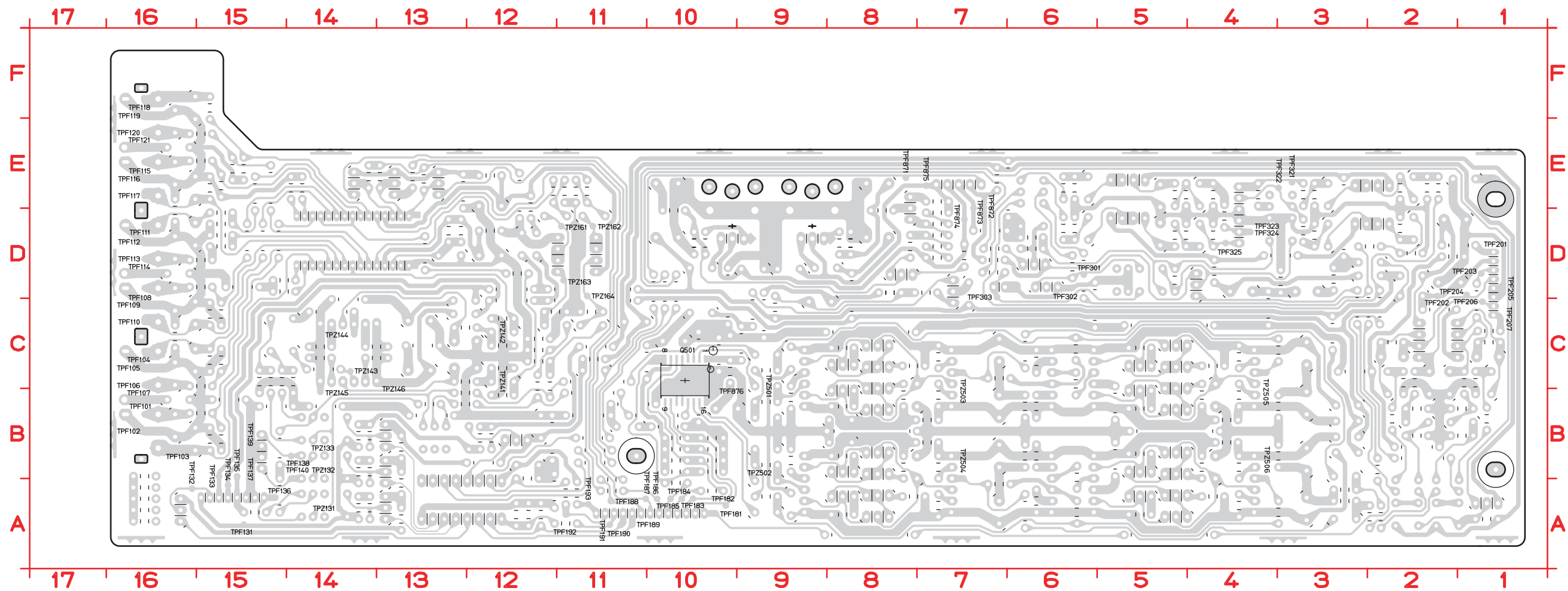

J202 E1
 Q501 C10

鉛フリー半田
 半田付けには、鉛フリー半田 (Sn-Ag-Cu) を使用してください。

Lead-free Solder
 When soldering, use the Lead-free Solder (Sn-Ag-Cu).

P102 A

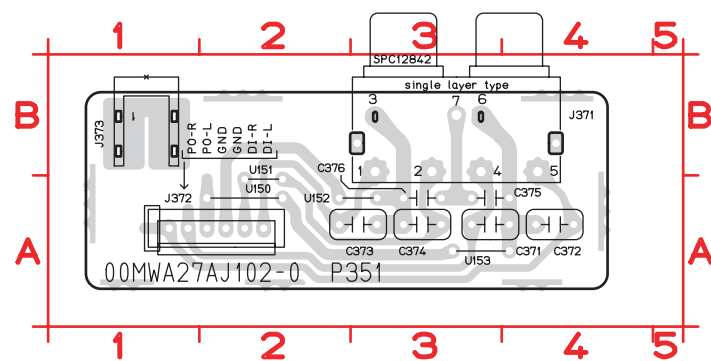

C371	A4	C376	A3	U151	A2
C372	A4	J371	B3	U152	A2
C373	A3	J372	A1	U153	A3
C374	A3	J373	B1		
C375	A3	U150	A2		

P102 B

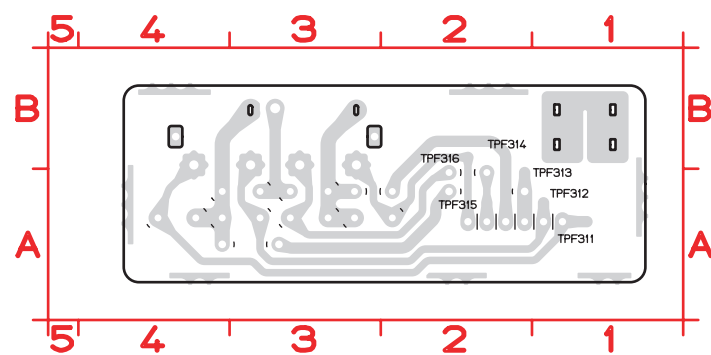

P201 A

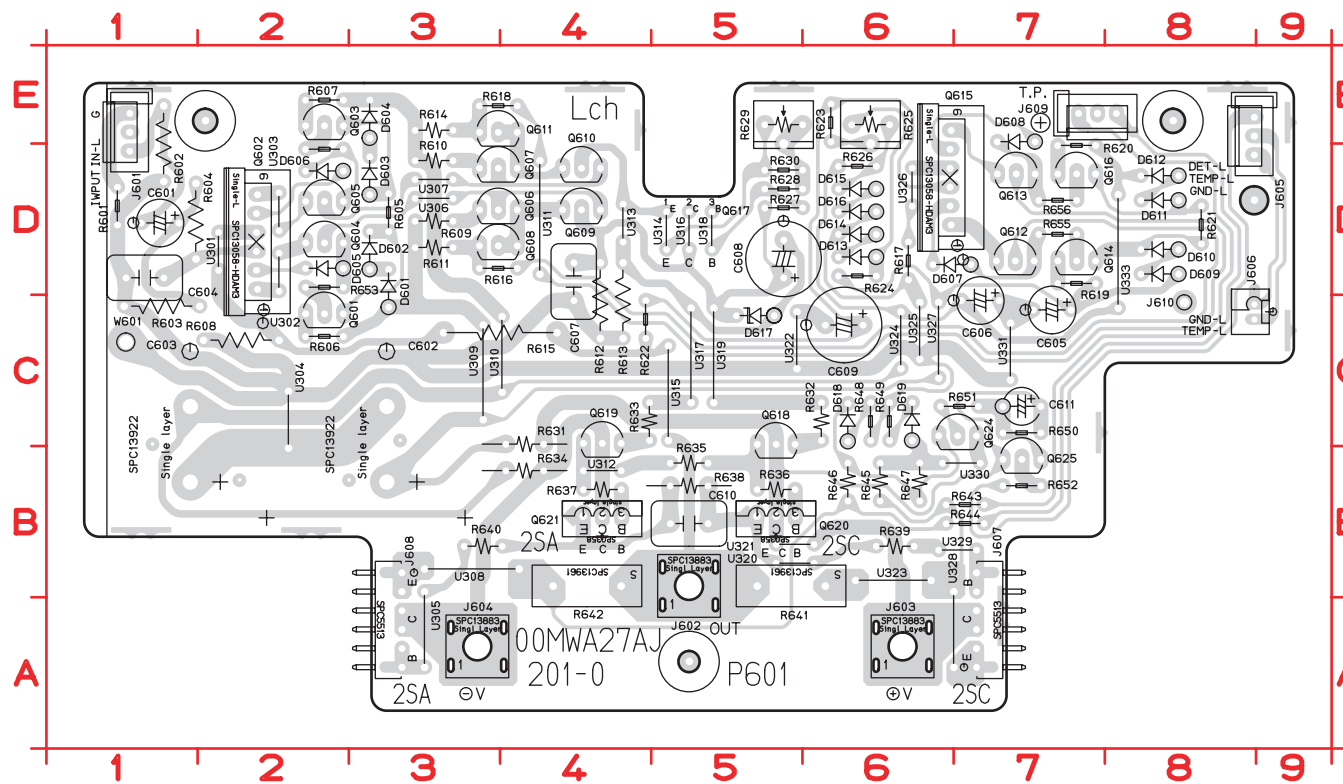

P201 B

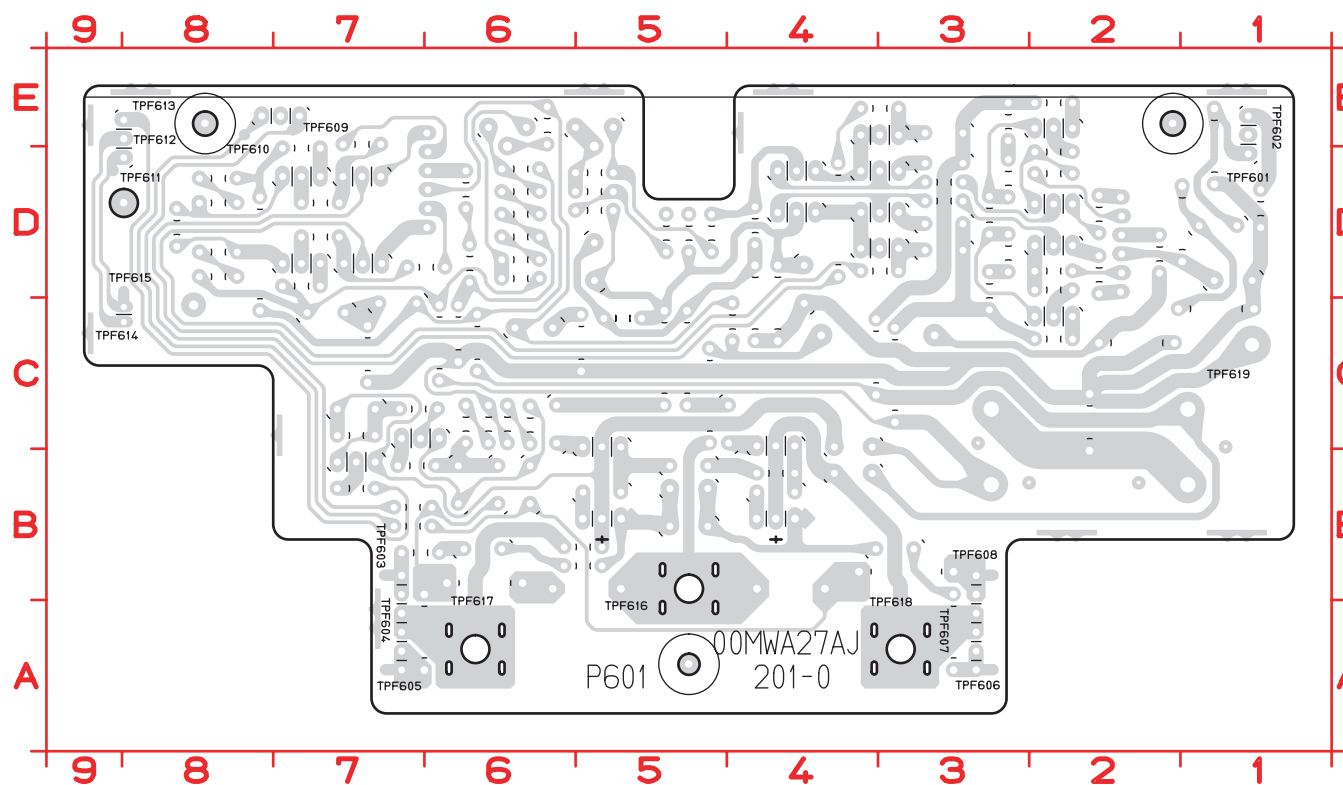

C601	D1	Q612	D7	R640	B4
C602	B3	Q613	D7	R641	B6
C603	B1	Q614	D7	R642	B4
C604	D1	Q615	D6	R643	B6
C605	C7	Q616	D7	R644	B6
C606	C7	Q617	D5	R645	B6
C607	C4	Q618	C5	R646	B6
C608	D5	Q619	C4	R647	B6
C609	C6	Q620	B5	R648	C6
C610	B5	Q621	B4	R649	C6
C611	C7	Q624	C7	R650	C7
D601	C3	Q625	B7	R651	C7
D602	D3	R601	D1	R652	B7
D603	D3	R602	E1	R653	D2
D604	E3	R603	C2	R654	D2
D605	D2	R604	D1	R655	D7
D606	D2	R605	D3	R656	D7
D607	D7	R606	C2	U301	D2
D608	E7	R607	E2	U302	D2
D609	D8	R608	C2	U303	D2
D610	D8	R609	D3	U304	B2
D611	D8	R610	D3	U305	A3
D612	D8	R611	D3	U306	D3
D613	D6	R612	D4	U307	D3
D614	D6	R613	C4	U308	B3
D615	D6	R614	E3	U309	C3
D616	D6	R615	C3	U310	C4
D617	C5	R616	D4	U311	D4
D618	C6	R617	D6	U312	B4
D619	C6	R618	E3	U313	D4
J601	E1	R619	D7	U314	D5
J602	B5	R620	D7	U315	C5
J603	A6	R621	D8	U316	D5
J604	A3	R622	C4	U317	C5
J605	E8	R623	E6	U318	D5
J606	C8	R624	D6	U319	C5
J607	A7	R625	E6	U320	B5
J608	B3	R626	D6	U321	B5
J609	E7	R627	D5	U322	C5
J610	C8	R628	D5	U323	B6
Q601	C2	R629	E5	U324	C6
Q602	D2	R630	D6	U325	C6
Q603	E2	R631	C4	U326	D6
Q604	D2	R632	C6	U327	C6
Q605	D2	R633	C4	U328	A7
Q606	D3	R634	B4	U329	B6
Q607	D3	R635	B5	U330	B6
Q608	D3	R636	B5	U331	C7
Q609	D4	R637	B4	U333	C8
Q610	D4	R638	B5	W601	C1
Q611	E3	R639	B6		

鉛フリー半田
半田付けには、鉛フリー半田 (Sn-Ag-Cu) を使用してください。
Lead-free Solder
When soldering, use the Lead-free Solder (Sn-Ag-Cu).

P202 A

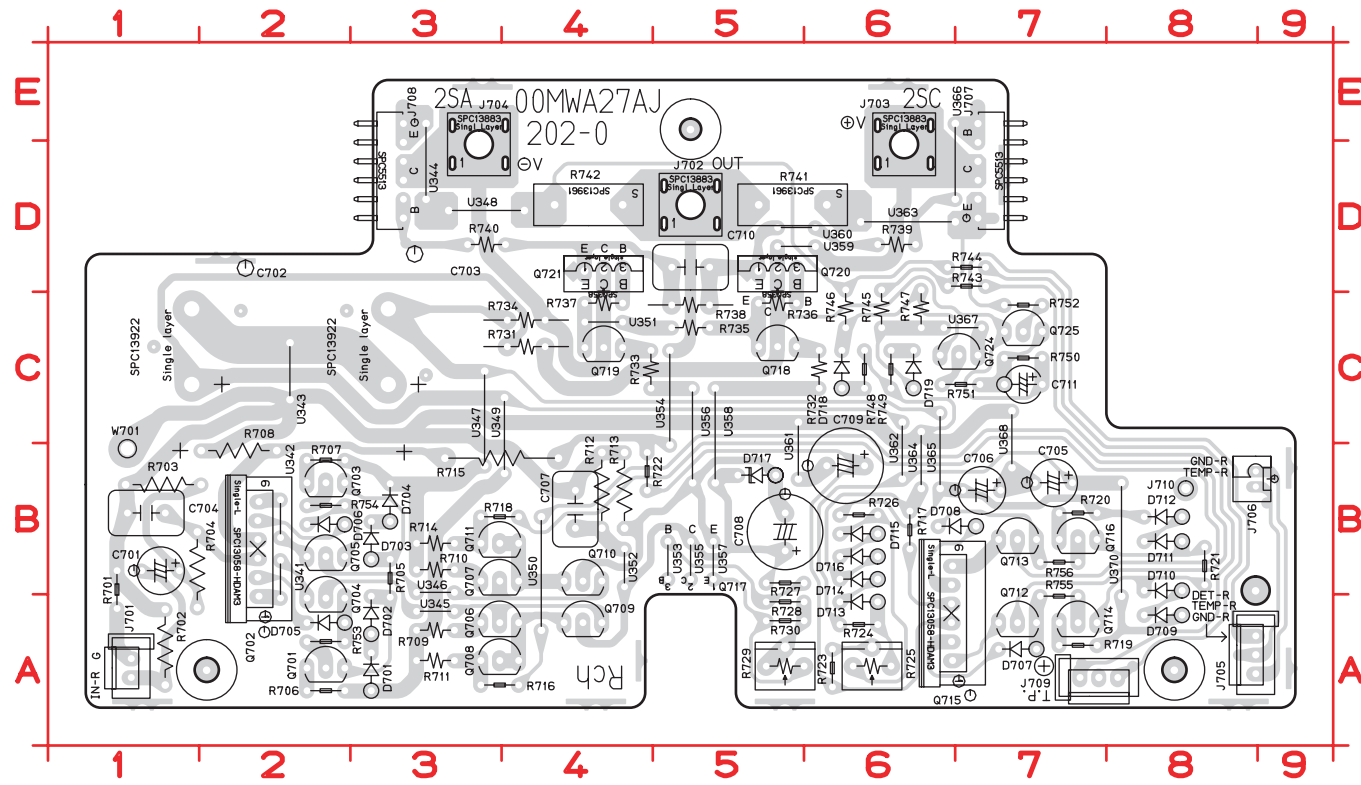

C701 B1	D718 C6	Q717 B5	R722 B4	R750 C7	U362 B6
C702 C1	D719 C6	Q718 C5	R723 A6	R751 C7	U363 D6
C703 C3	J701 A1	Q719 C4	R724 A6	R752 C7	U364 B6
C704 B1	J702 D5	Q720 D5	R725 A6	R753 A2	U365 B6
C705 B7	J703 D6	Q721 D4	R726 B6	R754 B2	U366 D7
C706 B7	J704 D3	Q724 C7	R727 B5	R755 A7	U367 C6
C707 B4	J705 A8	Q725 C7	R728 A5	R756 B7	U368 B7
C708 B5	J706 B8	R701 B1	R729 A5	U341 A2	U370 A8
C709 B6	J707 D7	R702 A1	R730 A6	U342 B2	W701 B1
C710 D5	J708 E3	R703 B2	R731 C4	U343 C2	
C711 C7	J709 A7	R704 B1	R732 C6	U344 D3	
D701 A3	J710 B8	R705 A3	R733 C4	U345 A3	
D702 A3	Q701 A2	R706 A2	R734 C4	U346 B3	
D703 B3	Q702 B2	R707 B2	R735 C5	U347 B3	
D704 B3	Q703 B2	R708 B2	R736 C5	U348 D3	
D705 A2	Q704 A2	R709 A3	R737 C4	U349 B4	
D706 B2	Q705 B2	R710 B3	R738 C5	U350 A4	
D707 A7	Q706 A3	R711 A3	R739 D6	U351 C4	
D708 B7	Q707 B3	R712 B4	R740 D4	U352 B4	
D709 A8	Q708 A3	R713 B4	R741 D6	U353 B5	
D710 B8	Q709 A4	R714 B3	R742 D4	U354 B5	
D711 B8	Q710 B4	R715 B3	R743 D6	U355 B5	
D712 B8	Q711 B3	R716 A4	R744 D6	U356 B5	
D713 A6	Q712 A7	R717 B6	R745 D6	U357 B5	
D714 B6	Q713 B7	R718 B3	R746 D6	U358 B5	
D715 B6	Q714 A7	R719 A7	R747 C6	U359 D5	
D716 B6	Q715 A6	R720 B7	R748 C6	U360 D5	
D717 B5	Q716 B7	R721 B8	R749 C6	U361 B5	

P202 B

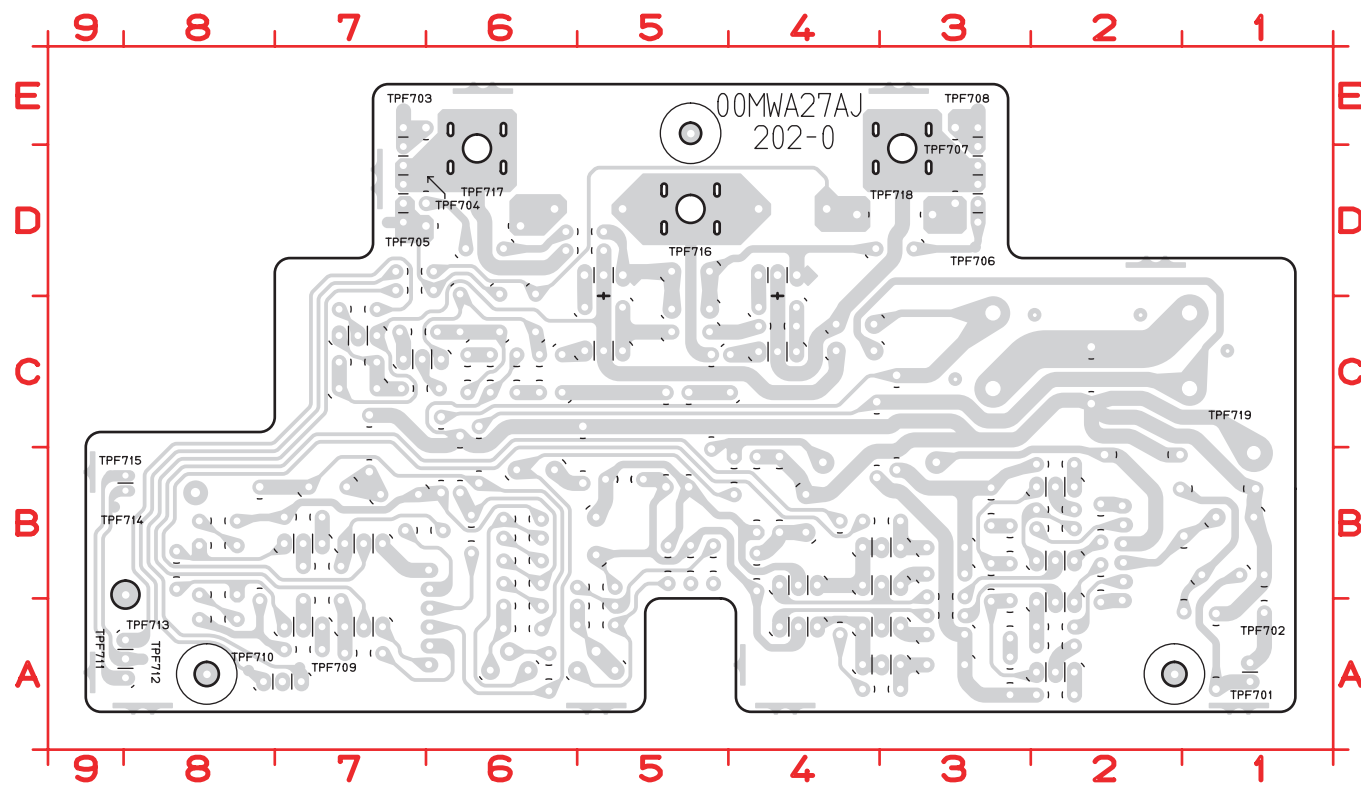

鉛フリー半田
 半田付けには、鉛フリー半田 (Sn-Ag-Cu) を使用してください。
Lead-free Solder
 When soldering, use the Lead-free Solder (Sn-Ag-Cu).

P203 A

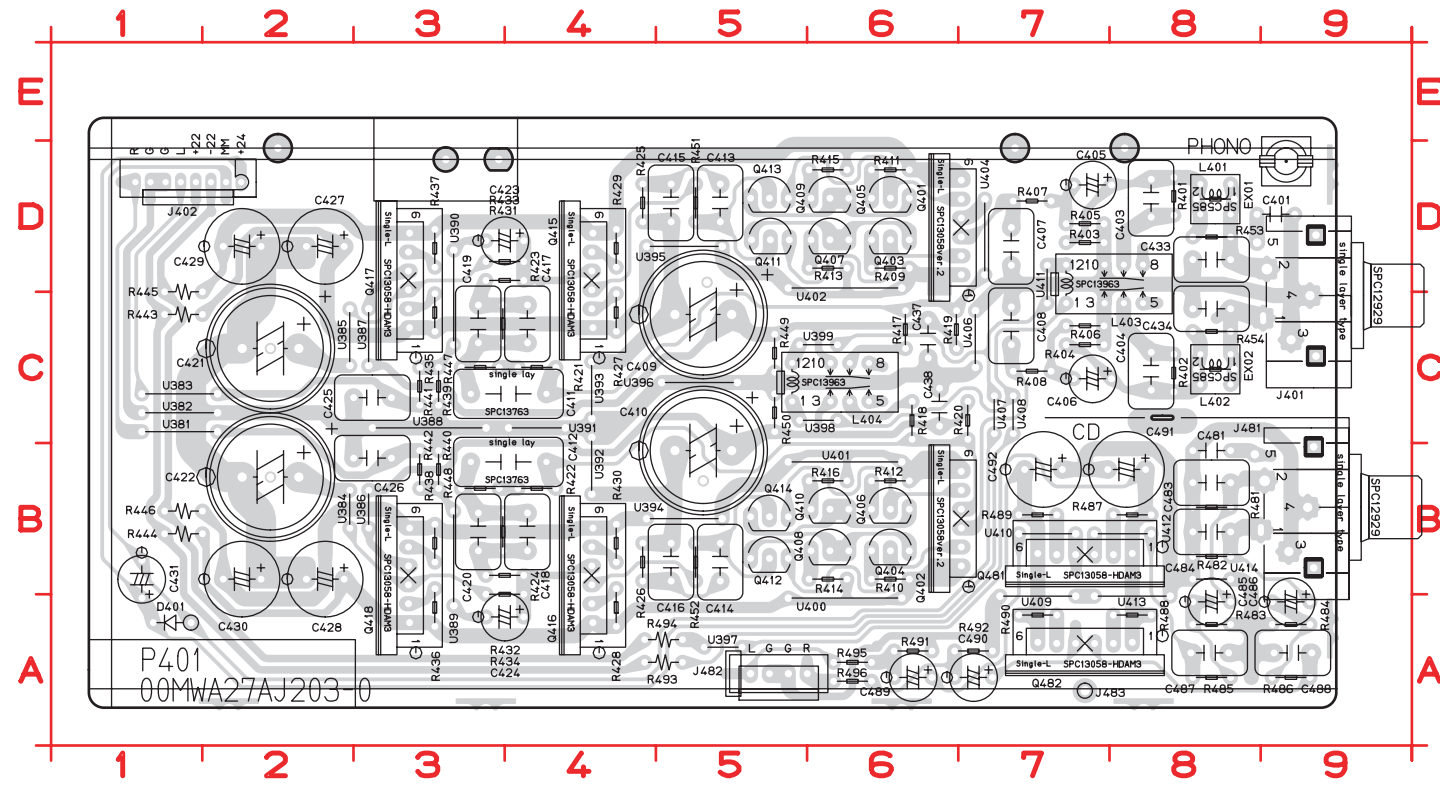

C401	D8	C433	D8	Q404	B6	R414	B6	R444	B2	U384	B2
C403	D8	C434	C8	Q405	D6	R415	D6	R445	D2	U385	C2
C404	C8	C437	C6	Q406	B6	R416	B6	R446	B2	U386	B3
C405	D8	C438	C6	Q407	D6	R417	C6	R447	C3	U387	C3
C406	C8	C481	B8	Q408	B6	R418	C6	R448	B3	U388	C3
C407	D7	C483	B8	Q409	D6	R419	C6	R449	C5	U389	A3
C408	C7	C484	B8	Q410	B6	R420	C7	R450	C5	U390	C3
C409	C5	C485	A8	Q411	D5	R421	C4	R451	D5	U391	C4
C410	B5	C486	A9	Q412	B5	R422	B4	R452	B5	U392	B4
C411	C3	C487	A8	Q413	D5	R423	C3	R453	D8	U393	C4
C412	B3	C488	A9	Q414	B5	R424	B3	R454	C8	U394	B4
C413	D5	C489	A6	Q415	D4	R425	D4	R481	B8	U395	D5
C414	B5	C490	A7	Q416	B4	R426	B4	R482	B8	U396	C5
C415	D5	C491	B8	Q417	D3	R427	C4	R483	A8	U397	A5
C416	B5	C492	B7	Q418	B3	R428	B4	R484	A9	U398	C5
C417	C4	D401	A1	Q481	B7	R429	D4	R485	A8	U399	C5
C418	B4	EX01	D8	Q482	A7	R430	B4	R486	A9	U400	A5
C419	C3	EX02	C8	R401	D8	R431	D3	R487	B8	U401	B5
C420	B3	J401	C9	R402	C8	R432	B3	R488	A8	U402	D5
C421	C2	J402	D2	R403	D7	R433	D4	R489	B7	U404	D7
C422	B2	J481	B9	R404	C7	R434	B4	R490	A7	U406	C7
C423	D4	J482	A5	R405	D7	R435	C3	R491	A6	U407	C7
C424	A4	J483	A7	R406	C7	R436	B3	R492	A6	U408	C7
C425	C3	L401	D8	R407	D7	R437	D3	R493	A5	U409	A7
C426	B3	L402	C8	R408	C7	R438	B3	R494	A5	U410	B7
C427	D2	L403	C7	R409	D6	R439	C3	R495	A6	U411	C7
C428	B2	L404	C5	R410	B6	R440	B6	R496	A6	U412	B7
C429	D2	Q401	D7	R411	D6	R441	C3	U381	C1	U413	A7
C430	B2	Q402	B7	R412	B6	R442	B3	U382	C1	U414	B8
C431	A1	Q403	D6	R413	D6	R443	C2	U383	C1		

P203 B

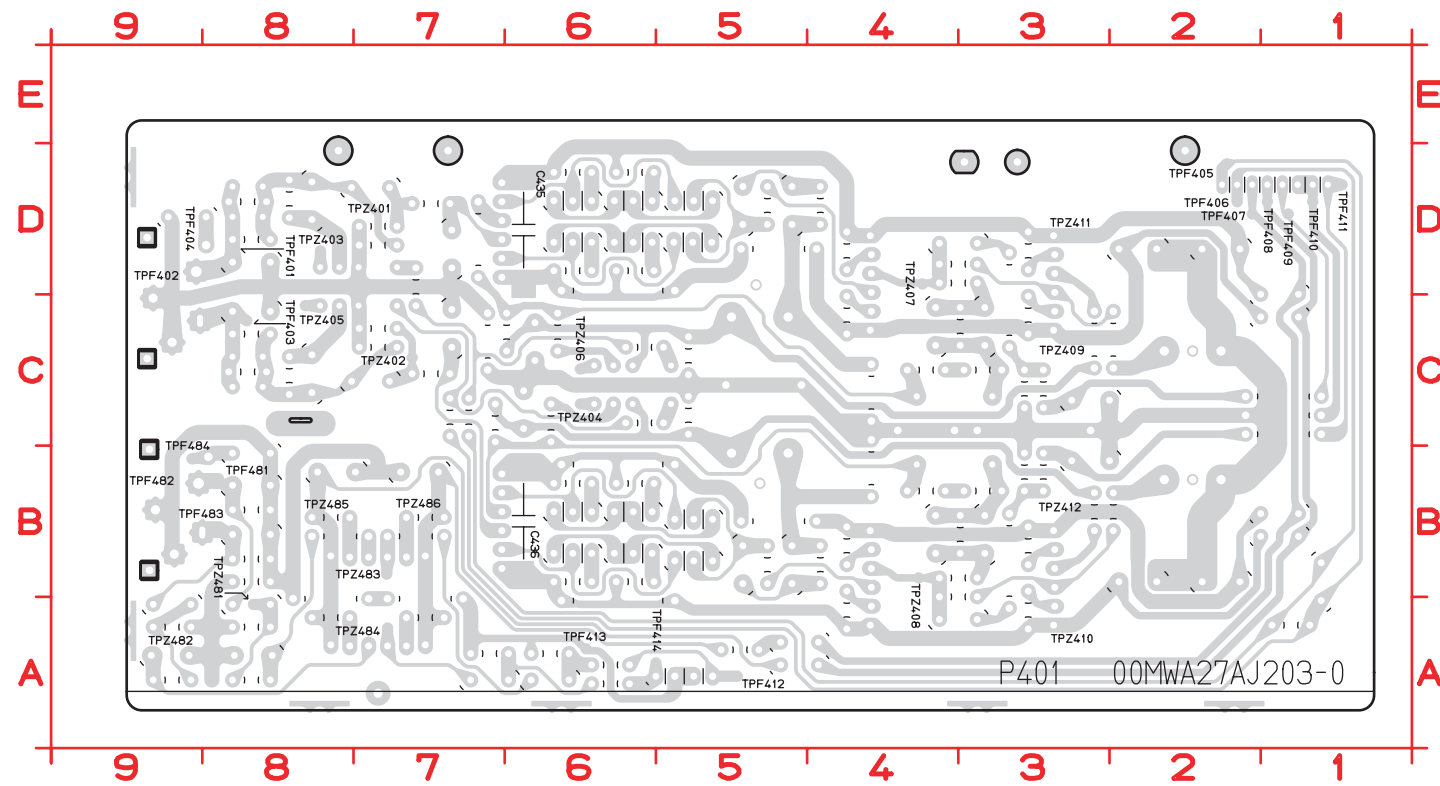

C435	D6
C436	B6

鉛フリー半田
半田付けには、鉛フリー半田 (Sn-Ag-Cu) を使用してください。
Lead-free Solder
When soldering, use the Lead-free Solder (Sn-Ag-Cu).

P204 A

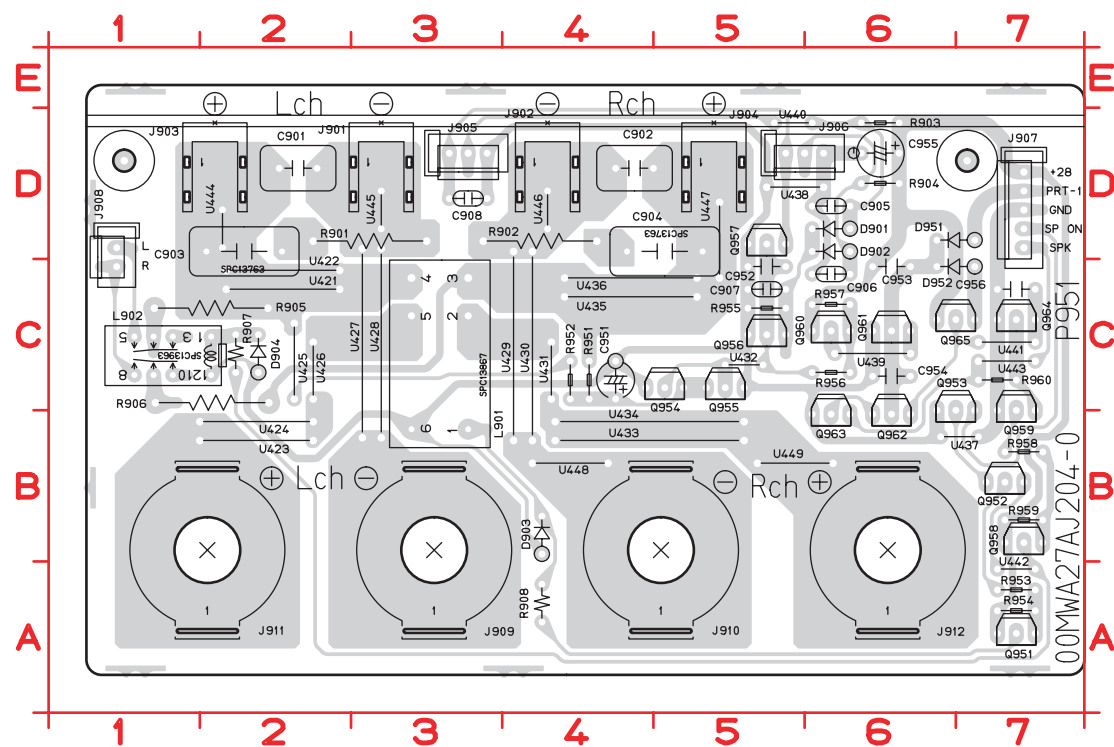

P204 B

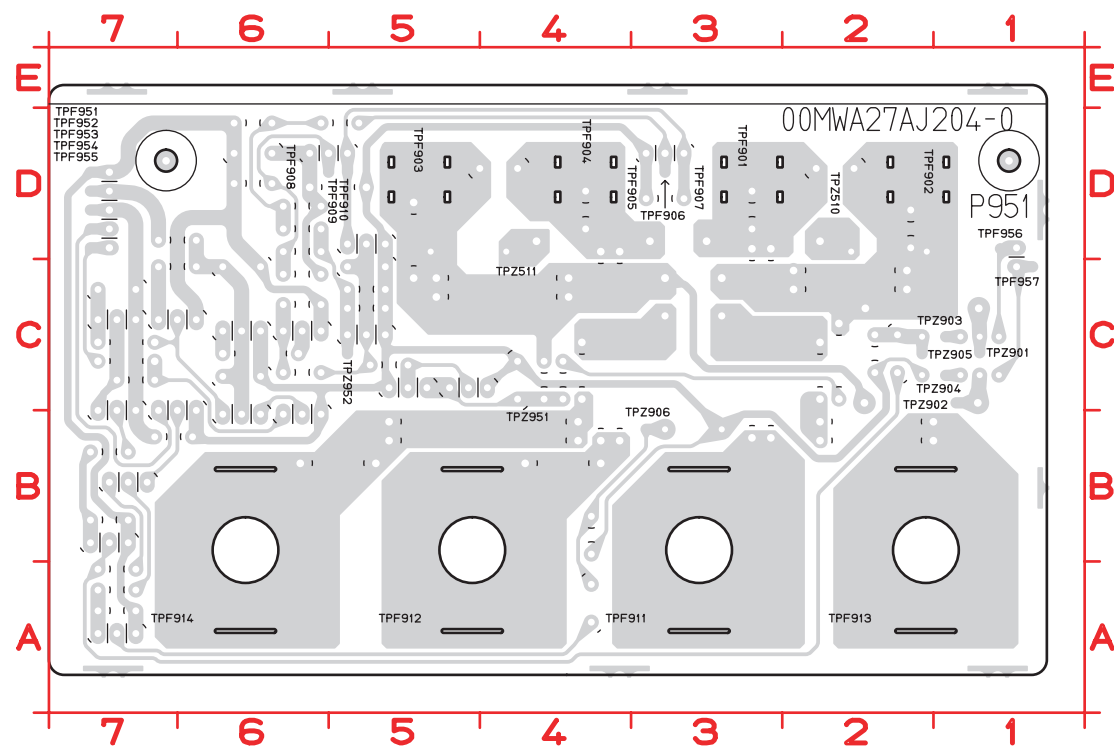

C901	D2	D904	C2	Q951	A7	R903	D6	U422	C2	U439	C6
C902	D5	D951	D7	Q952	B7	R904	D6	U423	B2	U440	D5
C903	D2	D952	C7	Q953	C7	R905	C2	U424	B2	U441	C7
C904	D5	J901	D3	Q954	C5	R906	C2	U425	C2	U442	A7
C905	D6	J902	D4	Q955	C5	R907	C2	U426	C2	U443	C7
C906	C6	J903	D2	Q956	C5	R908	A4	U427	B3	U444	D2
C907	C5	J904	D5	Q957	D5	R951	C4	U428	B3	U445	D3
C908	D3	J905	D3	Q958	B7	R952	C4	U429	B4	U446	D4
C951	C4	J906	D5	Q959	C7	R953	A7	U430	B4	U447	C5
C952	C5	J907	D7	Q960	C6	R954	A7	U431	C4	U448	B4
C953	C6	J908	D1	Q961	C6	R955	C5	U432	C5	U449	B5
C954	C6	J909	B3	Q962	B6	R956	C6	U433	B4		
C955	D6	J910	B5	Q963	B6	R957	C6	U434	B4		
C956	C7	J911	B2	Q964	C7	R958	B7	U435	C4		
D901	D6	J912	B6	Q965	C7	R959	B7	U436	C4		
D902	D6	L901	B3	R901	D3	R960	C7	U437	B6		
D903	B4	L902	C2	R902	D3	U421	C2	U438	D5		

鉛フリー半田

半田付けには、鉛フリー半田 (Sn-Ag-Cu) を使用してください。

Lead-free Solder

When soldering, use the Lead-free Solder (Sn-Ag-Cu).

P205 A

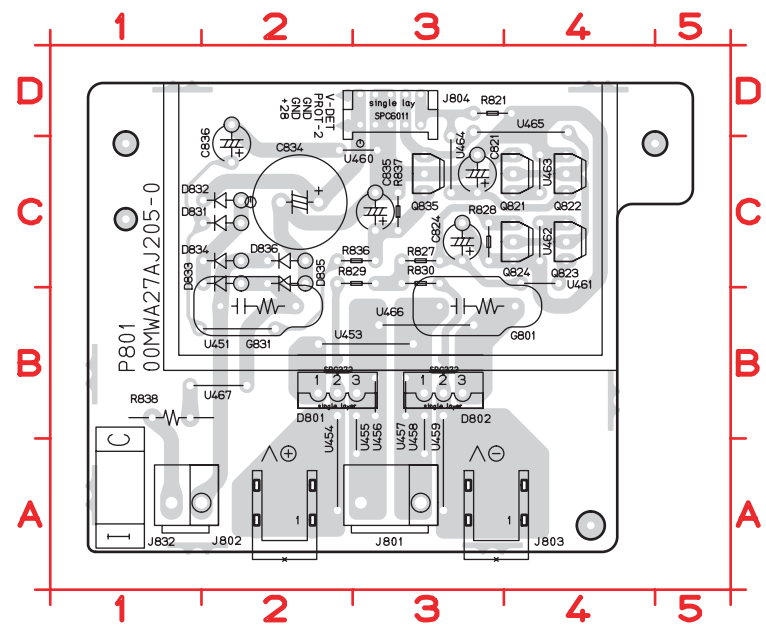

- | | | | |
|------|----|------|----|
| C821 | C3 | R821 | D4 |
| C824 | C3 | R827 | C3 |
| C834 | C2 | R828 | C3 |
| C835 | C3 | R829 | C2 |
| C836 | C2 | R830 | C3 |
| D801 | B2 | R836 | C2 |
| D802 | B3 | R837 | C3 |
| D811 | C2 | R838 | B1 |
| D832 | C2 | U451 | B1 |
| D833 | C2 | U453 | B2 |
| D834 | C2 | U454 | A2 |
| D835 | C2 | U455 | A3 |
| D836 | C2 | U456 | B3 |
| G801 | B4 | U457 | B3 |
| G811 | B2 | U458 | A3 |
| J801 | A3 | U459 | A3 |
| J802 | A2 | U460 | C2 |
| J803 | A3 | U461 | C4 |
| J804 | D3 | U462 | C4 |
| J832 | A2 | U463 | C4 |
| Q821 | C4 | U464 | C3 |
| Q822 | C4 | U465 | D3 |
| Q823 | C4 | U466 | B3 |
| Q824 | C4 | U467 | B2 |
| Q835 | C3 | | |

P205 B

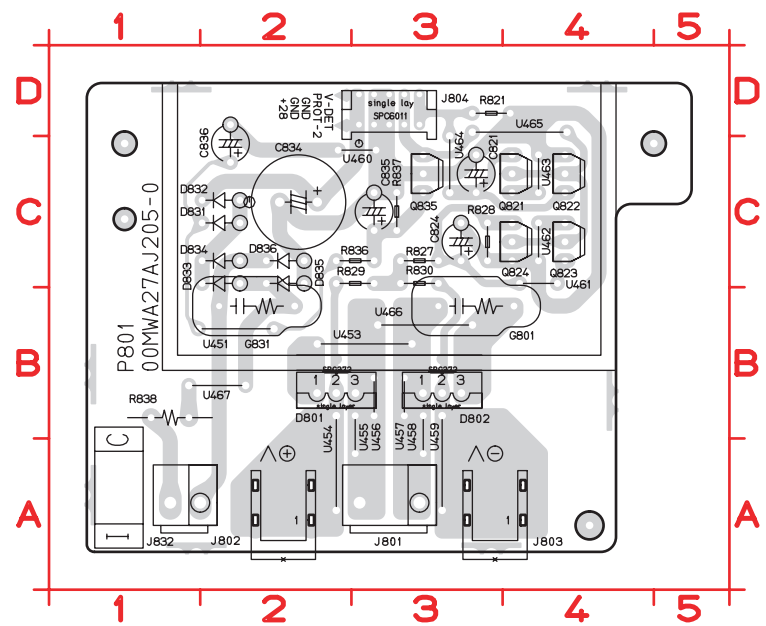

P206 A

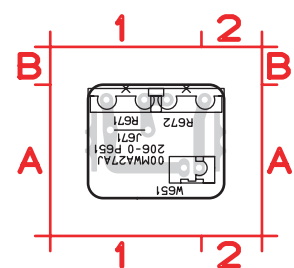

- | | |
|------|----|
| J671 | A1 |
| R671 | A1 |
| R672 | A1 |
| W651 | A1 |

P206 B

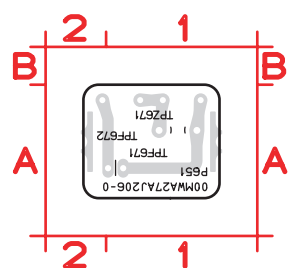

P207 A

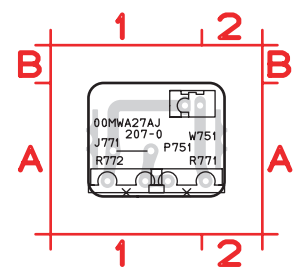

- | | |
|------|----|
| J771 | A1 |
| R771 | A1 |
| R772 | A1 |
| W751 | A1 |

P207 B

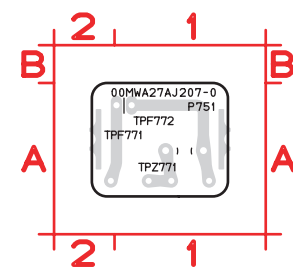

鉛フリー半田
半田付けには、鉛フリー半田 (Sn-Ag-Cu) を使用してください。
Lead-free Solder
When soldering, use the Lead-free Solder (Sn-Ag-Cu).

P208 A

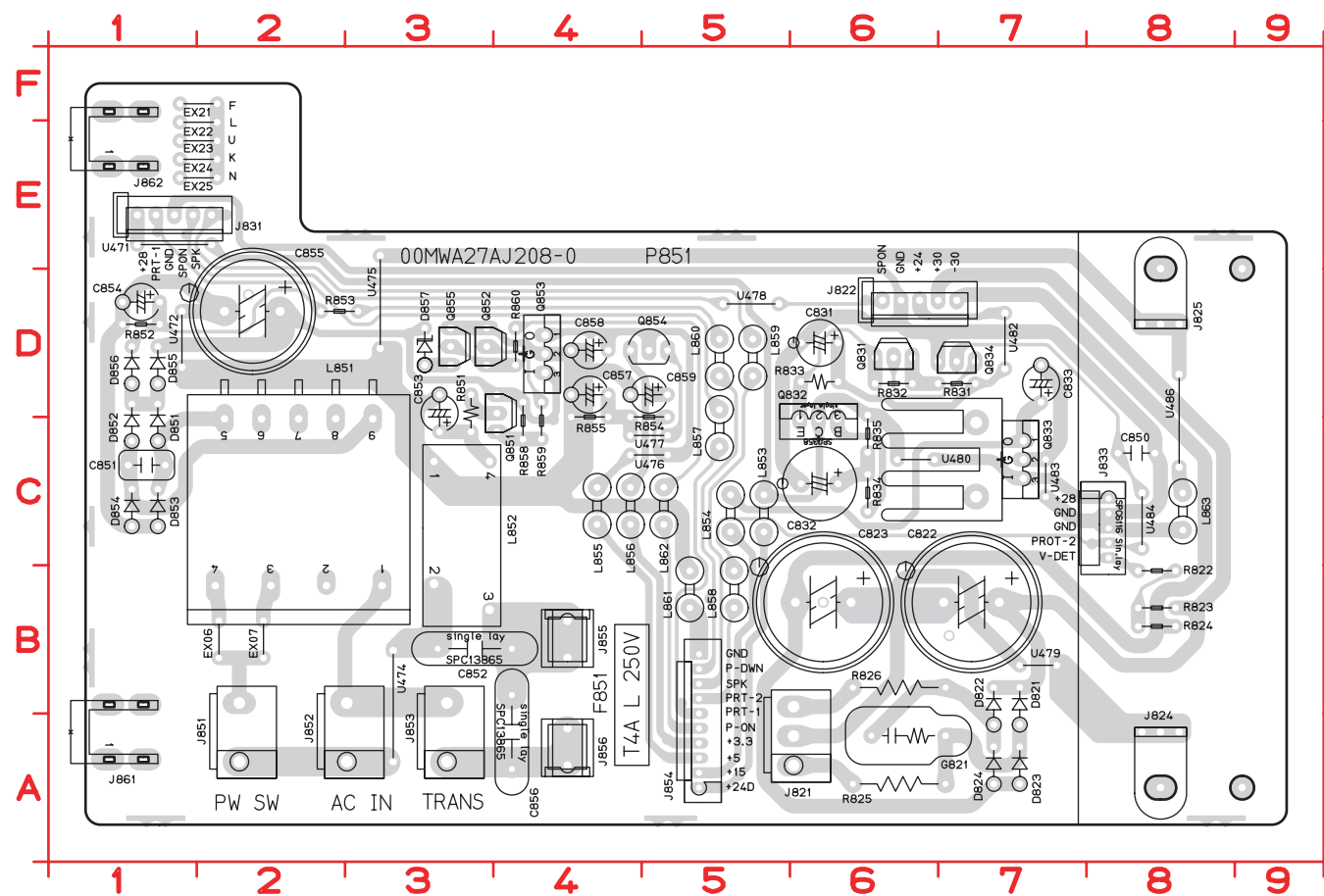

P208 B

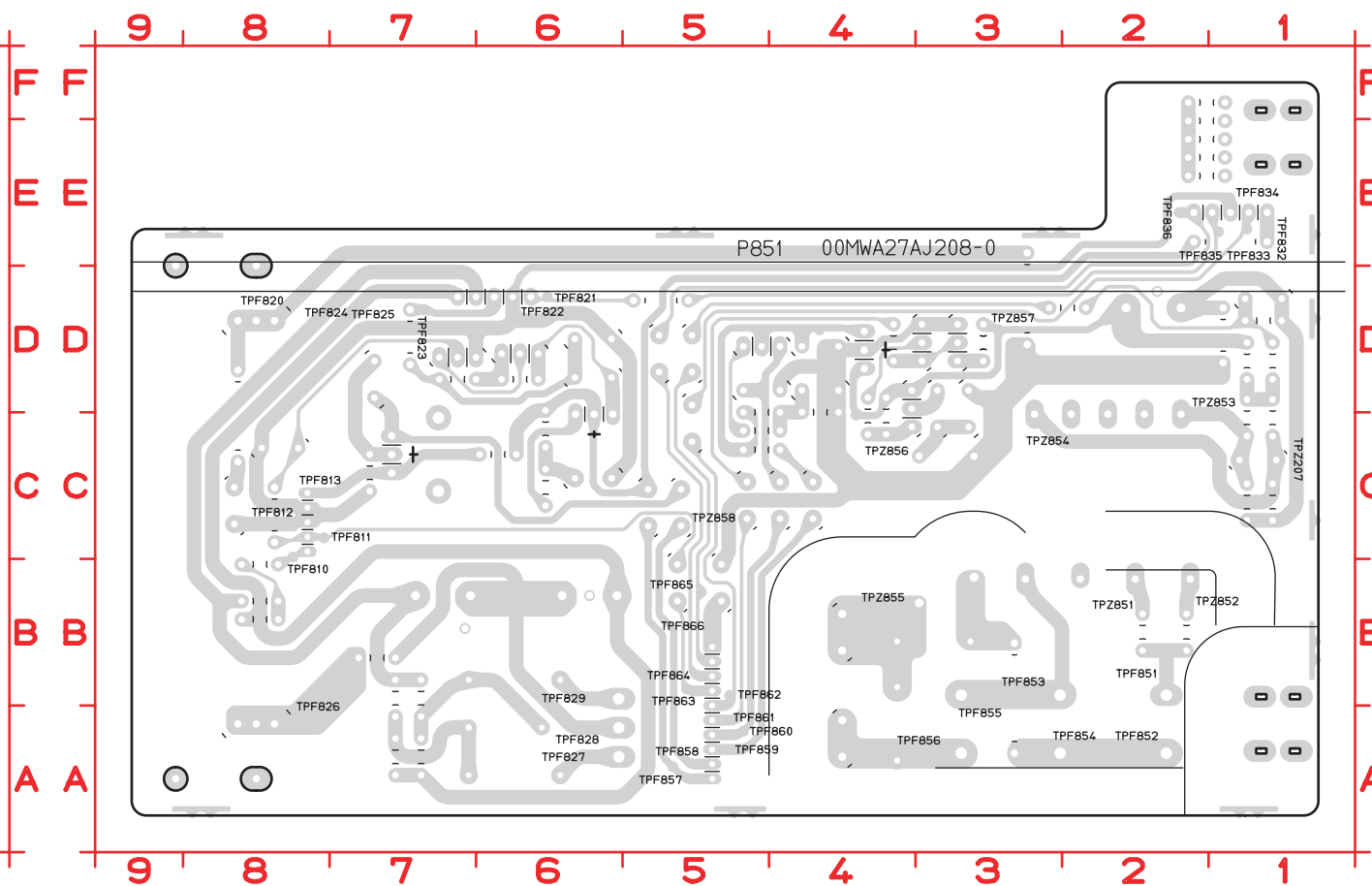

C822	B7	D823	A7	J821	A6	L854	C5	Q854	D5	R858	D4
C823	B6	D824	A7	J822	D6	L855	C4	Q855	D3	R859	C4
C831	D6	D851	C1	J824	A8	L856	C4	R822	B8	R860	D4
C832	C6	D852	C1	J825	E8	L857	D5	R823	B8	U471	E1
C833	D7	D853	C1	J831	E1	L858	B5	R824	B8	U472	D1
C850	C8	D854	C1	J833	C8	L859	D5	R825	A6	U474	A3
C851	C1	D855	D1	J851	A2	L860	D5	R826	B6	U475	D3
C852	B3	D856	D1	J852	A3	L861	B5	R831	D7	U476	C4
C853	C3	D857	D3	J853	A3	L862	C5	R832	D6	U477	C4
C854	D1	EX06	B2	J854	A5	L863	C8	R833	D6	U478	D5
C855	D2	EX07	B2	J855	B4	Q831	D6	R834	C6	U479	B7
C856	B4	EX21	F1	J856	A4	Q832	C6	R835	C6	U480	C6
C857	D4	EX22	E1	J861	A1	Q833	C7	R851	C3	U482	D7
C858	D4	EX23	E1	J862	E1	Q834	D7	R852	D1	U483	C7
C859	D5	EX24	E1	L851	C2	Q851	D4	R853	D3	U484	C8
D821	A7	EX25	E1	L852	C3	Q852	D3	R854	D4	U486	C8
D822	A7	G821	A7	L853	C5	Q853	D4	R855	D4		

鉛フリー半田

半田付けには、鉛フリー半田 (Sn-Ag-Cu) を使用してください。

Lead-free Solder

When soldering, use the Lead-free Solder (Sn-Ag-Cu).

P209 A

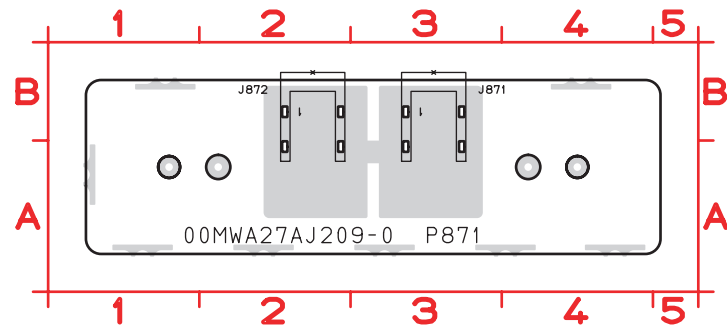

J871 B3
J872 B2

P211 A

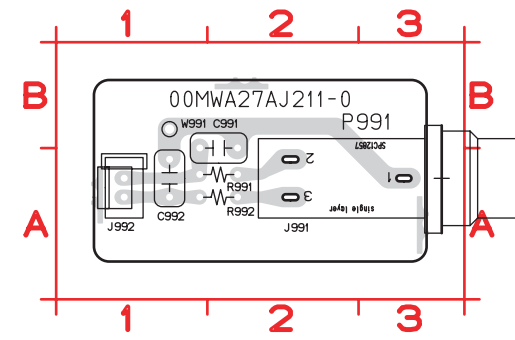

C991 B2
C992 A1
J991 A3
J992 A1
R991 A1
R992 A1
W991 B1

P211 B

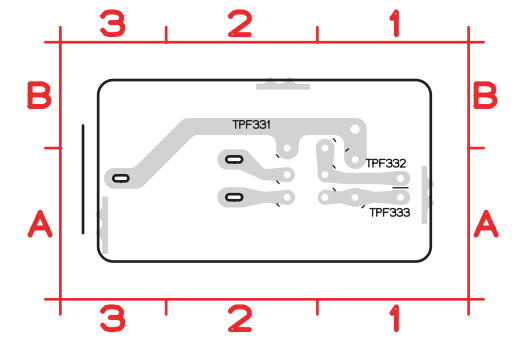

P209 B

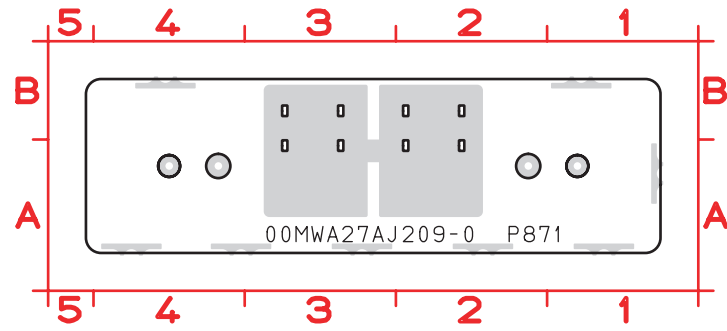

P212 A

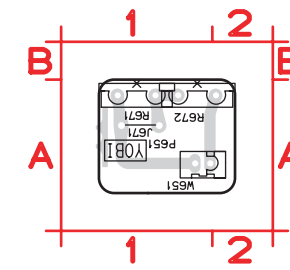

P212 B

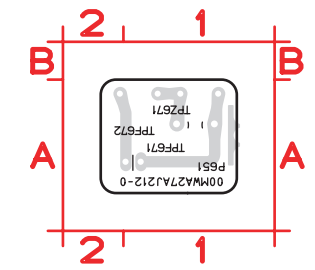

P210 A

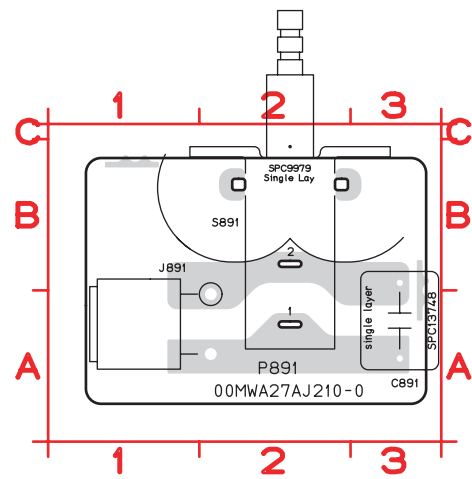

C891 A3
J891 A2
S891 B2

P210 B

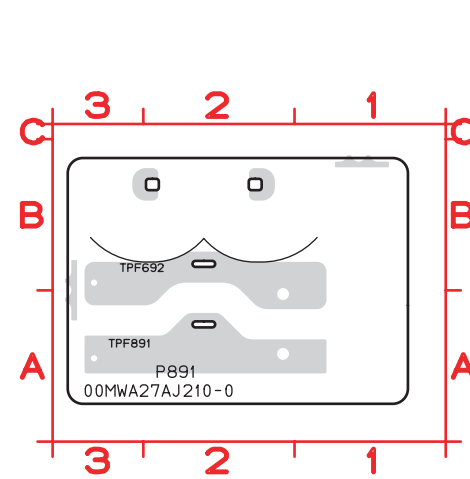

P213 A

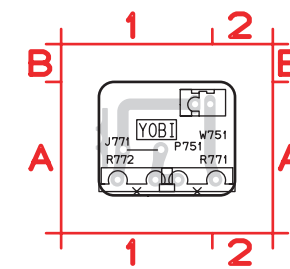

P213 B

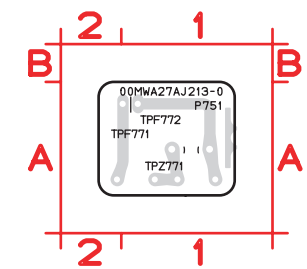

鉛フリー半田
半田付けには、鉛フリー半田 (Sn-Ag-Cu) を使用してください。
Lead-free Solder
When soldering, use the Lead-free Solder (Sn-Ag-Cu).

P301 A

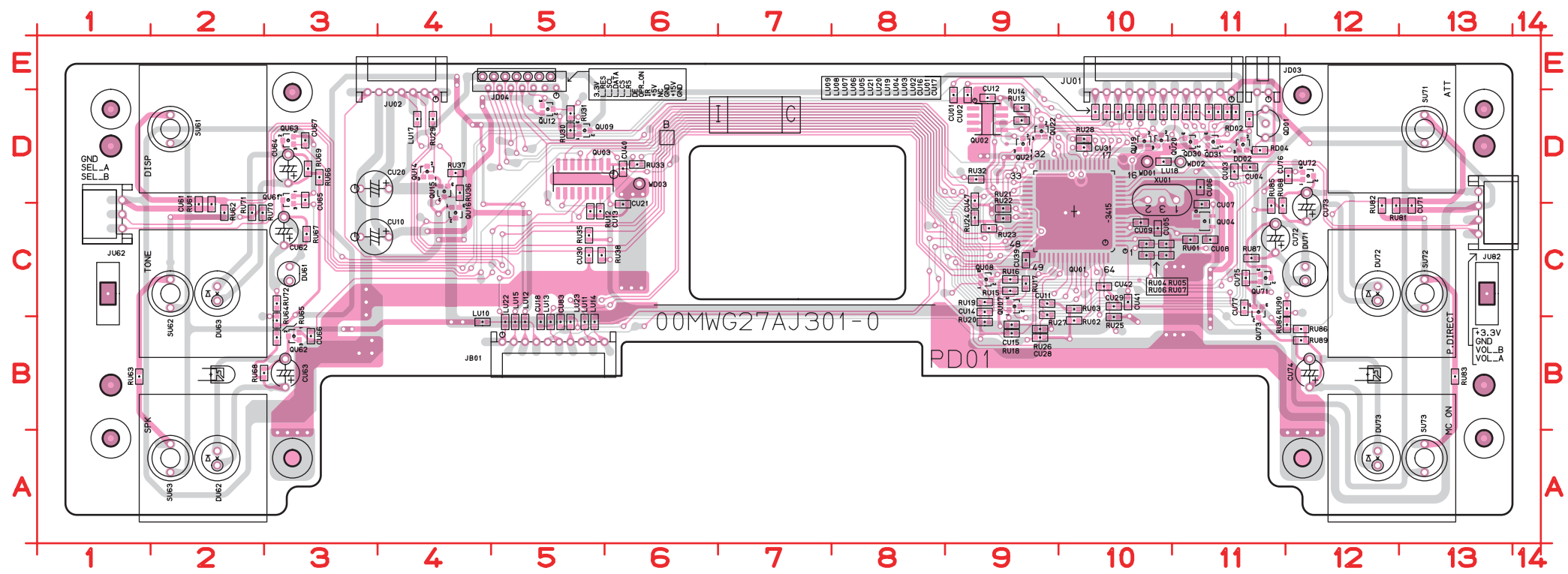

CU01	D9	CU83	B5	QU04	C11	RU28	D10
CU02	D9	DD02	D11	QU07	C9	RU29	D4
CU03	D11	DU61	C3	QU08	C9	RU30	D5
CU04	D11	DU62	A2	QU09	D5	RU31	D5
CU05	C10	DU63	C2	QU12	D5	RU32	D9
CU06	D11	DU71	C12	QU14	D4	RU33	D6
CU07	C11	DU72	C12	QU15	D4	RU35	C5
CU08	C11	DU73	A12	QU16	C4	RU36	D4
CU09	C10	JB01	B5	QU19	D10	RU37	D4
CU10	C4	JD03	D11	QU20	D10	RU38	C5
CU11	C9	JD04	E5	QU21	D9	RU61	C2
CU12	D9	JU01	D11	QU22	D9	RU62	C2
CU13	C5	JU02	D4	QU61	D3	RU63	B1
CU14	C9	JU62	C1	QU62	B3	RU64	B3
CU15	B9	JU82	D13	QU63	D3	RU65	B3
CU16	D11	LU01	D11	QU71	C11	RU66	D3
CU17	D11	LU02	D11	QU72	D12	RU67	C3
CU18	B5	LU03	D11	QU73	C11	RU68	B3
CU20	D4	LU04	D11	RD02	D11	RU69	D3
CU21	C6	LU05	D10	RD04	D11	RU70	C2
CU28	B9	LU06	D10	RU01	C11	RU71	C2
CU29	C10	LU07	D10	RU02	B10	RU72	C3
CU30	C5	LU08	D10	RU03	C10	RU81	C12
CU31	D10	LU09	D10	RU04	C10	RU82	C12
CU39	C9	LU10	B4	RU05	C10	RU83	B13
CU40	D6	LU11	B5	RU06	C10	RU84	B12
CU41	C10	LU12	B5	RU07	C10	RU85	C11
CU42	C10	LU13	B5	RU12	C5	RU86	B12
CU47	D9	LU14	B5	RU13	D9	RU87	C11
CU61	C2	LU15	B5	RU14	D9	RU88	C11
CU62	C3	LU17	D4	RU15	C9	RU89	B12
CU63	B3	LU18	D10	RU16	C9	RU90	C12
CU64	D3	LU19	D11	RU17	C9	SU61	D2
CU65	D3	LU20	D10	RU18	B9	SU62	C2
CU66	B3	LU21	D10	RU19	C9	SU63	A2
CU67	D3	LU22	B5	RU20	B9	SU71	D13
CU71	C13	LU23	B5	RU21	C9	SU72	C13
CU72	C11	QD01	D11	RU22	C9	SU73	A13
CU73	C12	QD30	D11	RU23	C9	WD01	D10
CU74	B12	QD31	D11	RU24	C9	WD02	D11
CU75	C11	QU01	C10	RU25	B10	WD03	D6
CU76	D12	QU02	D9	RU26	B9	XU01	D10
CU77	C11	QU03	D5	RU27	C9		

P301 B

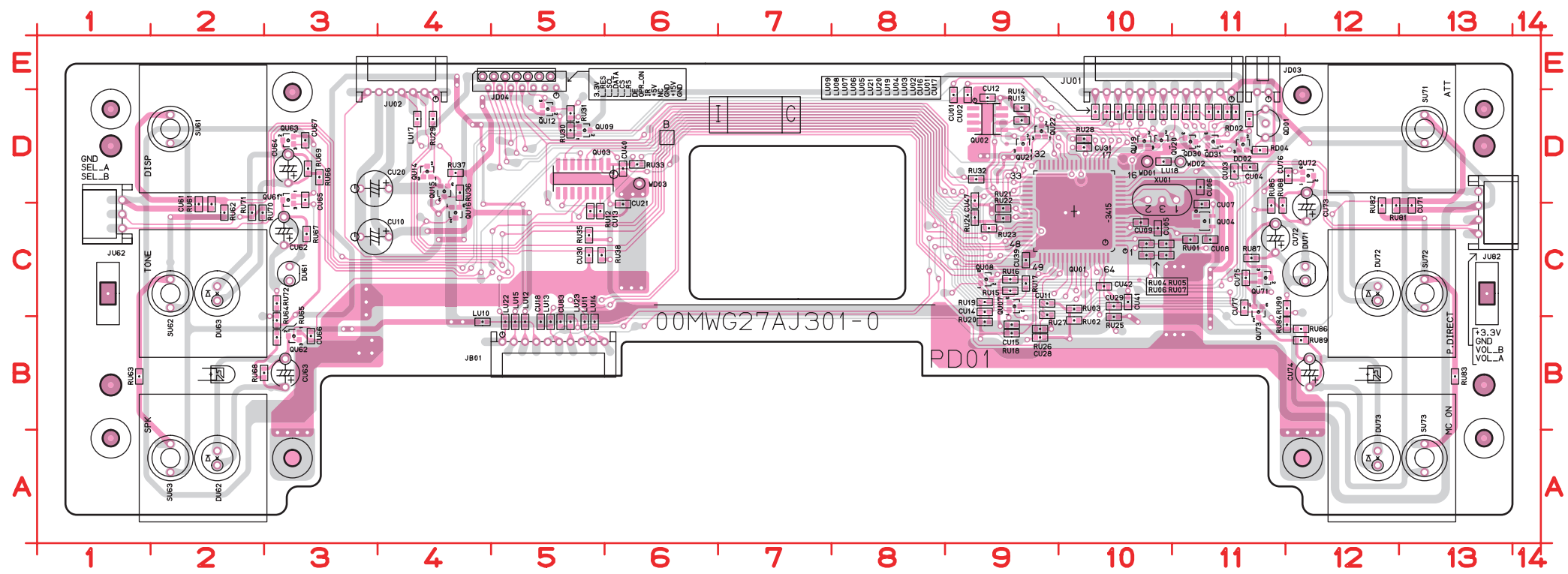

CD01	B4	DU02	B5	RU09	B2
CD02	B4	JD01	C4	RU10	B5
CD03	B4	JD02	B4	RU11	B5
CD04	B4	QD02	B4	RU34	C2
CD05	B4	QU05	B2		
CD06	A4	QU06	B5		
CD07	A4	QU11	C1		
CD08	B4	RD01	C4		
CD09	B4	RD03	B5		
CD10	B4	RD05	B4		
CD12	B4	RD06	B4		
CD13	C5	RD07	B4		
CU23	C2	RD08	C4		
CU24	C2	RD09	B4		
CU26	B2	RD10	C4		
CU27	B5	RD12	C4		
DU01	B2	RU08	B2		

鉛フリー半田
半田付けには、鉛フリー半田 (Sn-Ag-Cu) を使用してください。

Lead-free Solder
When soldering, use the Lead-free Solder (Sn-Ag-Cu).

P302 A

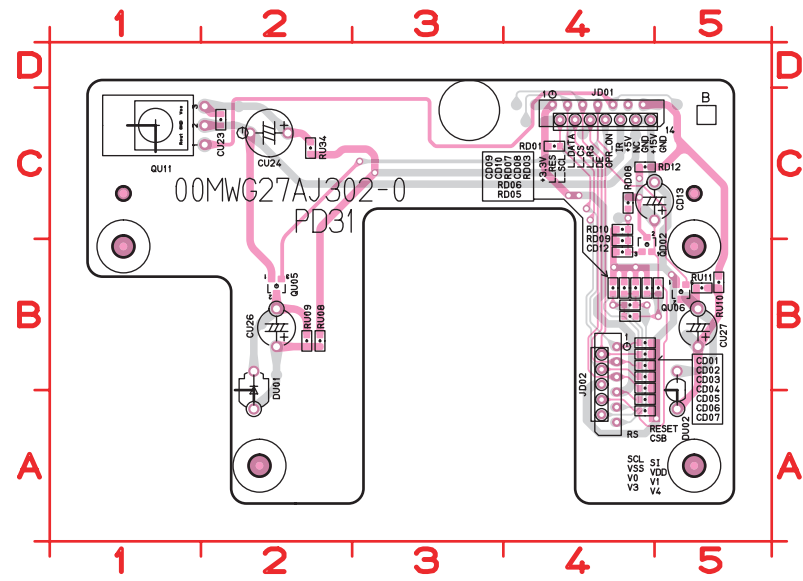

CD01 B4	JD02 B4
CD02 B4	QD02 B4
CD03 B4	QU05 B2
CD04 B4	QU06 B5
CD05 B4	QU11 C1
CD06 A4	RD01 C4
CD07 A4	RD03 B5
CD08 B4	RD05 B4
CD09 B4	RD06 B4
CD10 B4	RD07 B4
CD12 B4	RD08 C4
CD13 C5	RD09 B4
CU23 C2	RD10 C4
CU24 C2	RD12 C4
CU26 B2	RU08 B2
CU27 B5	RU09 B2
DU01 B2	RU10 B5
DU02 B5	RU11 B5
JD01 C4	RU34 C2

P302 B

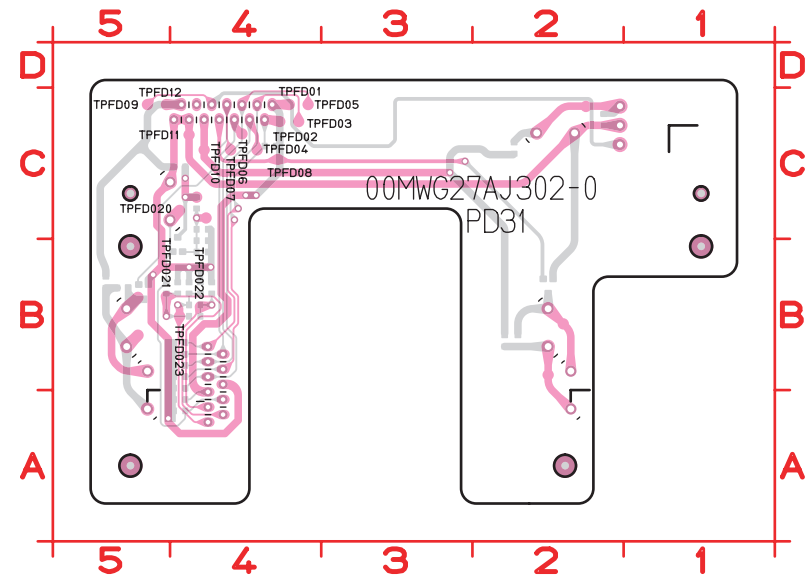

P303 A

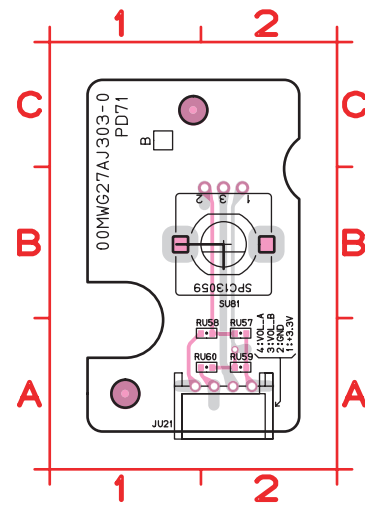

JU21 A2
RU57 A2
RU58 A2
RU59 A2
RU60 A2
SU81 B2

P303 B

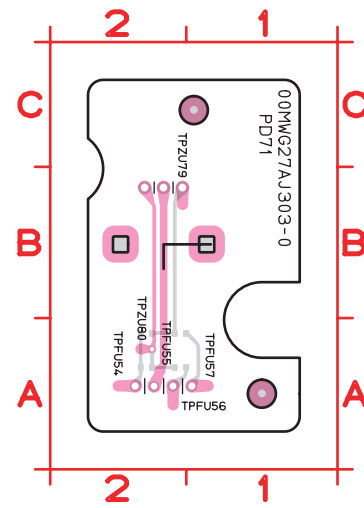

鉛フリー半田
半田付けには、鉛フリー半田 (Sn-Ag-Cu) を使用してください。

Lead-free Solder
When soldering, use the Lead-free Solder (Sn-Ag-Cu).

P304 A

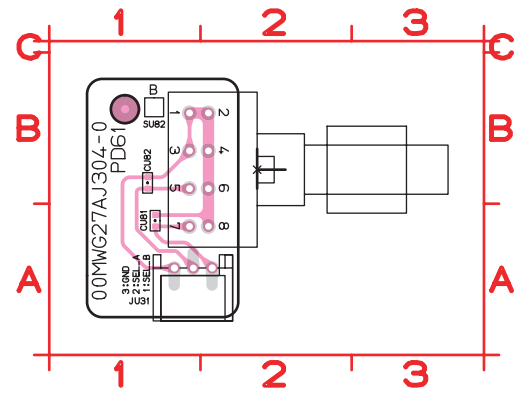

- CU81 A1
- CU82 B1
- JU31 A2
- SU82 B2

P304 B

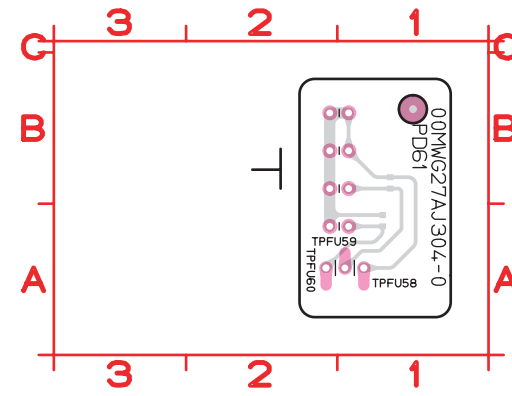

P305 A

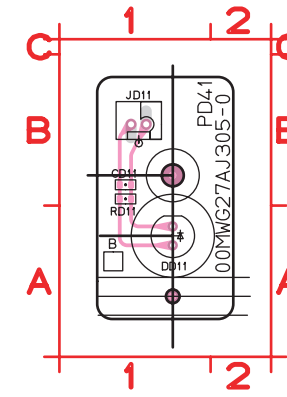

- CD11 B1
- DD11 A1
- JD11 B1
- RD11 B1

P305 A

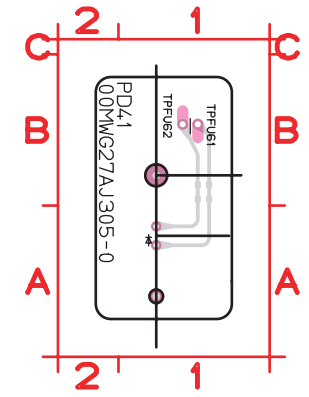

P306 A

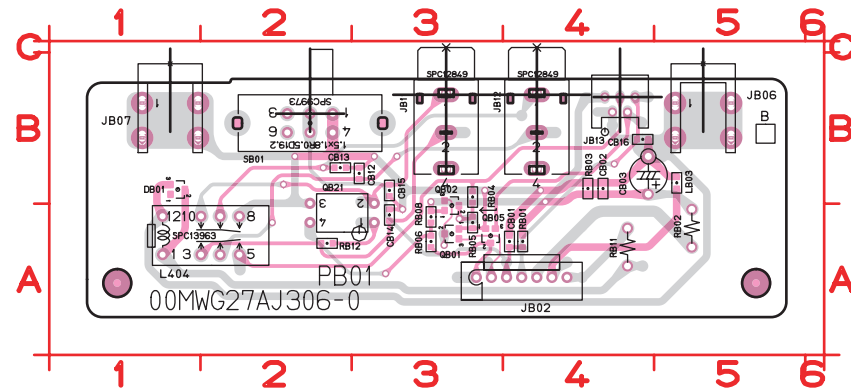

- | | | |
|---------|---------|---------|
| CB01 A4 | JB07 B1 | RB02 A5 |
| CB02 B4 | JB11 C3 | RB03 B4 |
| CB03 B4 | JB12 C4 | RB04 B3 |
| CB12 B3 | JB13 B4 | RB05 A3 |
| CB13 B2 | L404 A1 | RB06 A3 |
| CB14 A3 | L803 B5 | RB08 A3 |
| CB15 B3 | QB01 A3 | RB11 A4 |
| CB16 B4 | QB02 A3 | RB12 A2 |
| DB01 B1 | QB05 A3 | SB01 B2 |
| JB02 A3 | QB21 B3 | |
| JB06 B5 | RB01 A4 | |

P306 B

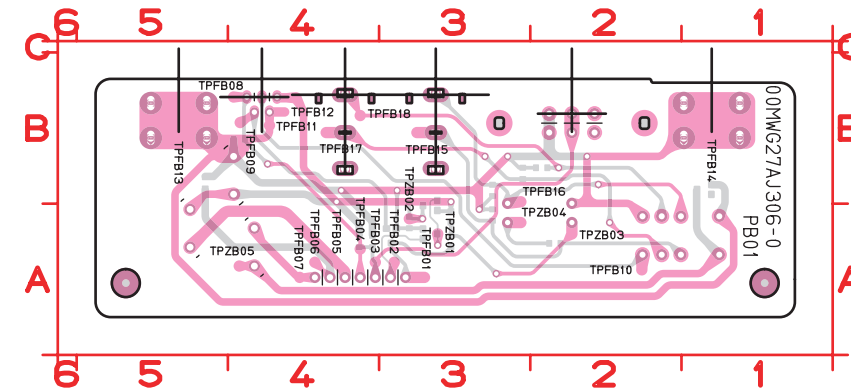

鉛フリー半田
半田付けには、鉛フリー半田 (Sn-Ag-Cu) を使用してください。

Lead-free Solder
When soldering, use the Lead-free Solder (Sn-Ag-Cu).

P307 A

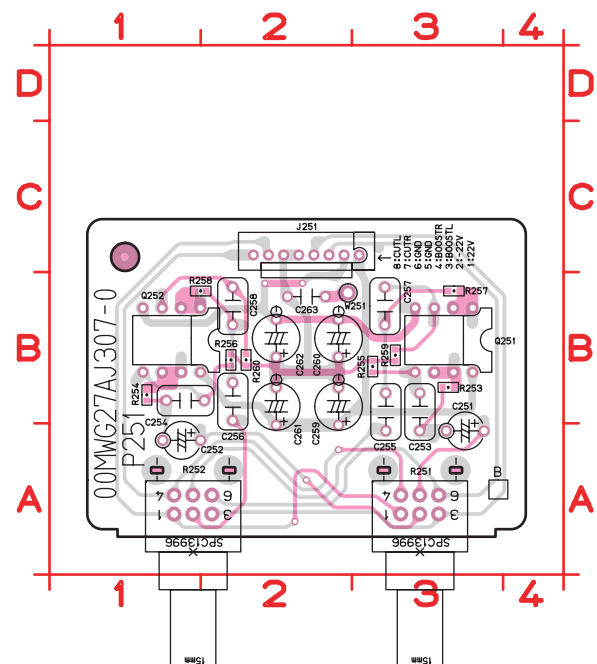

C251 A3	Q251 B3
C252 A2	Q252 B2
C253 A3	R251 A3
C254 B1	R252 A1
C255 A3	R253 B3
C256 B2	R254 B1
C257 B3	R255 B3
C258 B2	R256 B2
C259 A2	R257 B3
C260 B2	R258 B2
C261 A2	R259 B3
C262 B2	R260 B2
C263 B2	W251 B2
J251 C3	

P307 B

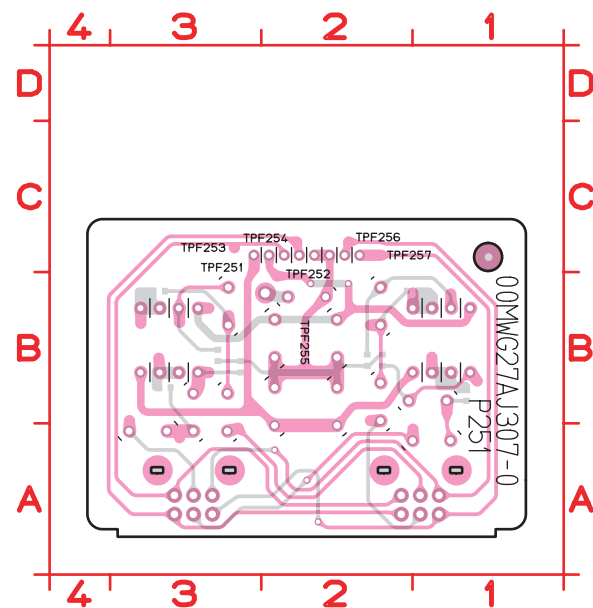

P601 A

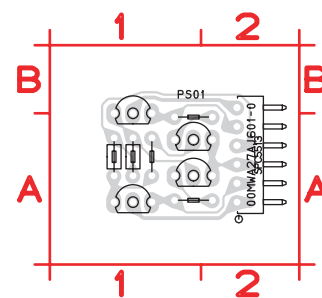

JS01 A2
QS01 A1
QS02 A1
QS03 A1
QS04 B1
RS01 A1
RS02 A1
RS03 A1
RS04 A1
RS05 A1

P601 B

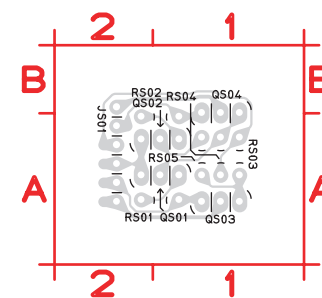

5501 A

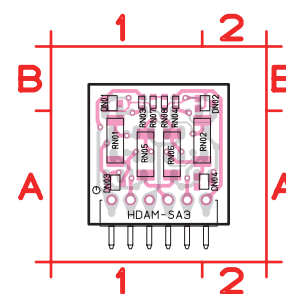

DN01 B1
DN02 B2
DN03 A1
DN04 A2
JN01 A1
RN01 A1
RN02 A2
RN03 B1
RN04 B1
RN05 A1
RN06 A1
RN07 B1
RN08 B1

5501 B

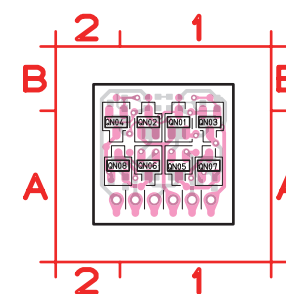

QN01 A1
QN02 A1
QN03 A1
QN04 A2
QN05 A1
QN06 A1
QN07 A1
QN08 A2

鉛フリー半田
半田付けには、鉛フリー半田 (Sn-Ag-Cu) を使用してください。
Lead-free Solder
When soldering, use the Lead-free Solder (Sn-Ag-Cu).

11. EXPLODED VIEW AND PARTS LIST

SYMBOL	STYLE	PARTS NAME
5110		+B.H.M.SCREW
5126		+B.H.TAP TITE SCREW W/WASHER
5128		+B.H.TAP TITE SCREW(B TYPE)
5129		+B.H.TAP TITE SCREW(W/T.L.WASHER)
5148		+B.H.M.SCREW(W/WASHER)
5150		+F.H.TAP TITE SCREW(B TYPE)
5204		+H.H.TAPT.BOLTS WITH FRANGE(S TIPE)
5405		TOOTHED LOCK WASHERS

MARK	MATERIAL/FINISH
(M)	STEEL/COPPER
(A)	STEEL/CHROMATE

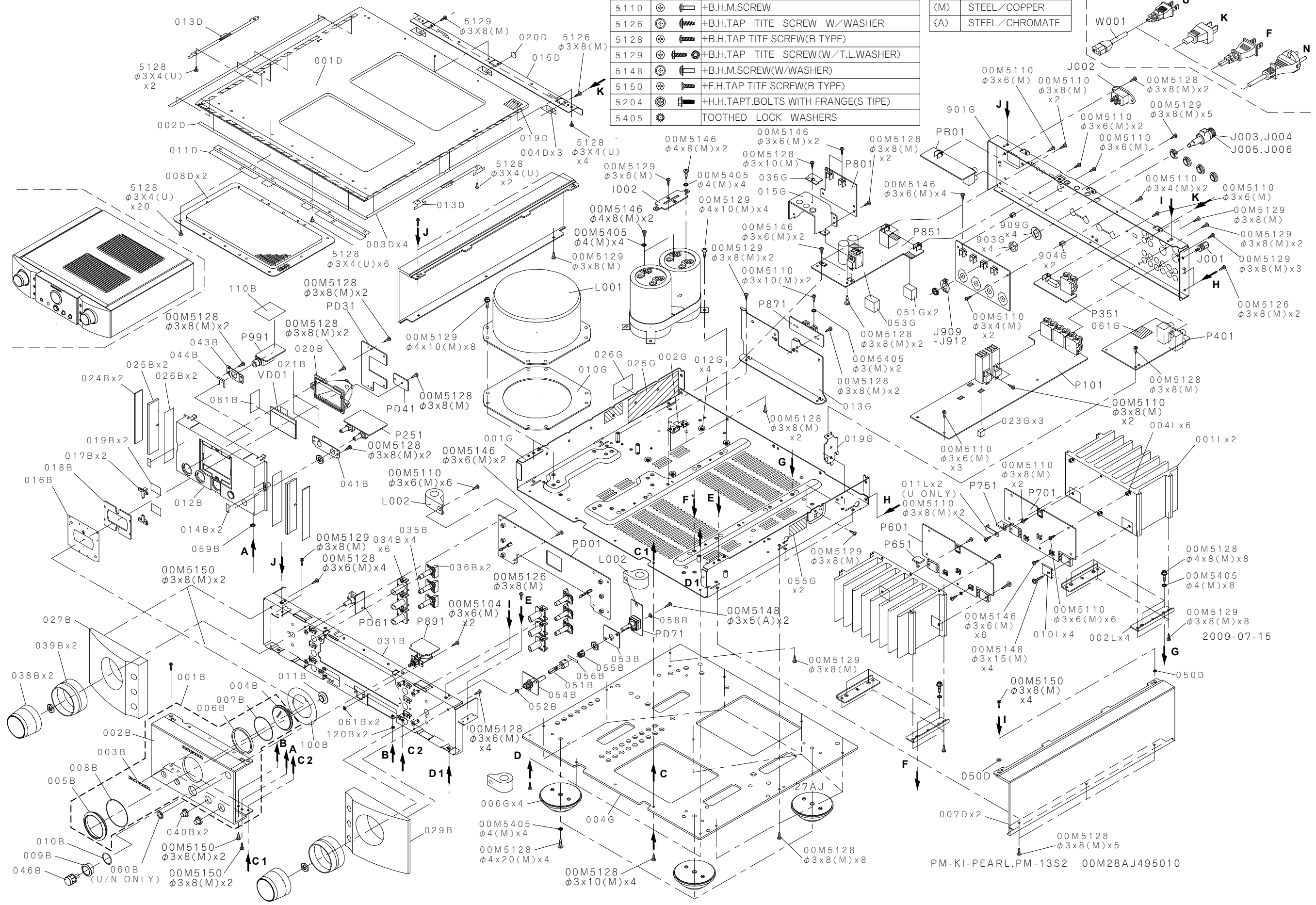
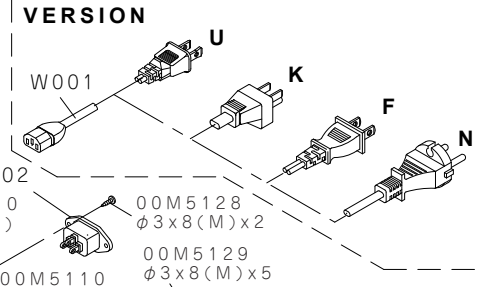

PM-KI-PEARL.PM-13S2 00M28AJ495010

2009-07-15

POS. NO.	VERS. COLOR	PART NO. (FOR EUR)	PART NO. (MJI)	PART NAME	DESCRIPTION
001D	FN		00M21AJ257110	TOP COVER ASSY GOLD	TOP COVER ASSY (GL)
001D	K1G		00M21AJ257110	TOP COVER ASSY GOLD	TOP COVER ASSY (GL)
001D	N1B	00M21AJ257010	00M21AJ257010	TOP COVER ASSY BLACK	TOP COVER ASSY (BL)
001D	U1B		00M21AJ257010	TOP COVER ASSY BLACK	TOP COVER ASSY (BL)
001B	FN		998402000450M	FRONT PANEL ASSY GOLD	FRONT PANEL ASSY(PM-13S2)
001B	K1G		998402000450M	FRONT PANEL ASSY GOLD	FRONT PANEL ASSY(PM-13S2)
001B	N1B	998402000460M	998402000460M	FRONT PANEL ASSU BLACK	FRONT PANEL ASSY(PM-KI-PEARL)
001B	U1B		998402000460M	FRONT PANEL ASSU BLACK	FRONT PANEL ASSY(PM-KI-PEARL)
006G	FN		407410012027M	LEG ASSY SILVER	LEGS(SILVER)
006G	K1G		407410012027M	LEG ASSY SILVER	LEGS(SILVER)
006G	N1B	407410012027M	407410012027M	LEG ASSY SILVER	LEGS(SILVER)
006G	U1B		407410012027M	LEG ASSY SILVER	LEGS(SILVER)
007D	FN		00M18AK249110	SIDE PANEL GOLD	SIDE PANEL AL GL
007D	K1G		00M18AK249110	SIDE PANEL GOLD	SIDE PANEL AL GL
007D	N1B	00M18AK249010	00M18AK249010	SIDE PANEL BLACK	SIDE PANEL AL BL
007D	U1B		00M18AK249010	SIDE PANEL BLACK	SIDE PANEL AL BL
004T	N1B	nsp	nsp	GOST FLY SHEET	GOST FLY SHEET PM-15S2 27AJ
011L	U1B		nsp	BRACKET-THERMAL SENSOR	BRACKET PM-15S2 27AJ
011B	FN		00M256J355030	IR LENS GOLD	IR LENS (GL)
011B	K1G		00M256J355030	IR LENS GOLD	IR LENS (GL)
011B	N1B	00M256J355042	00M256J355042	IR LENS BLACK	IR LENS
011B	U1B		00M256J355042	IR LENS BLACK	IR LENS
012B		00M10AJ105050	00M10AJ105050	FRONT MOLD CHASSIS	FRONT MOLD CHASSIS
016B	FN		nsp	LCD ESCUTCHEON GOLD	LCD ESC (GL)
016B	K1G		nsp	LCD ESCUTCHEON GOLD	LCD ESC (GL)
016B	N1B	nsp	nsp	LCD ESCUTCHEON BLACK	LCD ESC (BL)
016B	U1B		nsp	LCD ESCUTCHEON BLACK	LCD ESC (BL)
017B		nsp	nsp	LCD ESCUTCHEON LENS	LCD ESC.LENS
018B		00M10AJ056010	00M10AJ056010	LCD ESCUTCHEON BUFFER	WINDOW BUFFER
024B		00M18AK355010	00M18AK355010	SIDE LENS	LENS SIDE
027B	FN		00M10AJ063110	ESCUTCHEON L GOLD	SIDE ESC. (L/GL)
027B	K1G		00M10AJ063110	ESCUTCHEON L GOLD	SIDE ESC. (L/GL)
027B	N1B	00M10AJ063010	00M10AJ063010	ESCUTCHEON L BLACK	SIDE ESC. (L/BL)
027B	U1B		00M10AJ063010	ESCUTCHEON L BLACK	SIDE ESC. (L/BL)
029B	FN		00M10AJ063140	ESCUTCHEON R GOLD	ESCUTCHEON R GL PM-15S2 27AJ
029B	K1G		00M10AJ063140	ESCUTCHEON R GOLD	ESCUTCHEON R GL PM-15S2 27AJ
029B	N1B	00M10AJ063020	00M10AJ063020	ESCUTCHEON R BLACK	ESCUTCHEON R BL
029B	U1B		00M10AJ063020	ESCUTCHEON R BLACK	ESCUTCHEON R BL
034B	FN		00M04AJ259210	BUSH-FUNCTION BUTTON GOLD	FUNCTION BUTTON BUSH GOLD
034B	K1G		00M04AJ259210	BUSH-FUNCTION BUTTON GOLD	FUNCTION BUTTON BUSH GOLD
034B	N1B	00M04AJ259010	00M04AJ259010	BUSH-FUNCTION BUTTON BLACK	FUNCTION BUTTON BUSH BLACK
034B	U1B		00M04AJ259010	BUSH-FUNCTION BUTTON BLACK	FUNCTION BUTTON BUSH BLACK
035B	FN		00M04AJ270120	FUNCTION BUTTON LIGHTING GOLD	FUNCTION BUTTON LIGHTING (GL)
035B	K1G		00M04AJ270120	FUNCTION BUTTON LIGHTING GOLD	FUNCTION BUTTON LIGHTING (GL)
035B	N1B	00M04AJ270020	00M04AJ270020	FUNCTION BUTTON LIGHTING BLACK	FUNCTION BUTTON LIGHTING (BL)
035B	U1B		00M04AJ270020	FUNCTION BUTTON LIGHTING BLACK	FUNCTION BUTTON LIGHTING (BL)
036B	FN		00M04AJ270130	FUNCTION BUTTON GOLD	FUNCTION BUTTON (GL)
036B	K1G		00M04AJ270130	FUNCTION BUTTON GOLD	FUNCTION BUTTON (GL)
036B	N1B	00M04AJ270030	00M04AJ270030	FUNCTION BUTTON BLACK	FUNCTION BUTTON (BL)
036B	U1B	00M04AJ270030	00M04AJ270030	FUNCTION BUTTON BLACK	FUNCTION BUTTON (BL)
038B	FN		00M10AJ154110	MASTER KNOB GOLD	MASTER KNOB (GL)
038B	K1G		00M10AJ154110	MASTER KNOB GOLD	MASTER KNOB (GL)
038B	N1B	00M10AJ154010	00M10AJ154010	MASTER KNOB BLACK	MASTER KNOB (BL)
038B	U1B		00M10AJ154010	MASTER KNOB BLACK	MASTER KNOB (BL)

NOTE : "nsp" PART IS LISTED FOR REFERENCE ONLY, D&M WILL NOT SUPPLY THESE PARTS.

POS. NO.	VERS. COLOR	PART NO. (FOR EUR)	PART NO. (MJI)	PART NAME	DESCRIPTION
039B	FN		00M04AJ353110	MASTER KNOB RING GOLD	MASTER KNOB RING (GL)
039B	K1G		00M04AJ353110	MASTER KNOB RING GOLD	MASTER KNOB RING (GL)
039B	N1B	00M04AJ353010	00M04AJ353010	MASTER KNOB RING BLACK	MASTER KNOB RING (BL)
039B	U1B		00M04AJ353010	MASTER KNOB RING BLACK	MASTER KNOB RING (BL)
040B	FN		00M10AJ154120	TONE KNOB GOLD	KNOB HEAD PHONE AL CAP GL
040B	K1G		00M10AJ154120	TONE KNOB GOLD	KNOB HEAD PHONE AL CAP GL
040B	N1B	00M10AJ154020	00M10AJ154020	TONE KNOB BLACK	KNOB HEAD PHONE AL CAP GL
040B	U1B		00M10AJ154020	TONE KNOB BLACK	KNOB HEAD PHONE AL CAP GL
041B		nsp	nsp	TONE VOLUME BRACKET	TONE PCB BRACKET
043B		nsp	nsp	HEAD PHONE BRACKET	HEAD PHONE BRACKET
044B		nsp	nsp	MET41-0191 (CLANP FOR HP JACK)	MET41-0191 (CLANP FOR HP JACK)
046B	FN		00M04AJ270110	POWER BUTTON GOLD	POWER BUTTON (GL)
046B	K1G		00M04AJ270110	POWER BUTTON GOLD	POWER BUTTON (GL)
046B	N1B	00M04AJ270010	00M04AJ270010	POWER BUTTON BLACK	POWER BUTTON (BL)
046B	U1B		00M04AJ270010	POWER BUTTON BLACK	POWER BUTTON (BL)
100B		nsp	nsp	SHIELD PET PM-15S2 27AJ	SHIELD PET PM-15S2 27AJ
051G		nsp	nsp	SPACER-POWER SUPP PCB BOTTOM	SPACER BUFFER PM-15S2 27AJ
053B		nsp	nsp	BRACKET (BACK)	BRACKET (BACK)
C001		134750088000M	134750088000M	LKG1J203MSGMZT FOR PM-KI-PEARL	LKG1J203MSGMZT FOR PM-KI-PEARL
C002		134750088000M	134750088000M	LKG1J203MSGMZT FOR PM-KI-PEARL	LKG1J203MSGMZT FOR PM-KI-PEARL
I002		nsp	nsp	GND PLATE FOR C001,C002	CONTACTER
J001		nsp	nsp	GLD GND TERMINAL W/M3 TAPTIGHT	GLD GND TERMINAL W/M3 TAPTIGHT
J003		00MYT01010360	00MYT01010360	WBT-0765 POLE TERMINAL RED	WBT-0765 POLE TERMINAL RED
J004		00MYT01010360	00MYT01010360	WBT-0765 POLE TERMINAL RED	WBT-0765 POLE TERMINAL RED
J005		00MYT01010370	00MYT01010370	WBT-0765 POLE TERMINAL WHT	WBT-0765 POLE TERMINAL WHT
J006		00MYT01010370	00MYT01010370	WBT-0765 POLE TERMINAL WHT	WBT-0765 POLE TERMINAL WHT
J099	K1G		nsp	SAFETY STICK FOR WBT TERMINAL	STOPPER FOR SPEAKER TERMINAL
J099	N1B	nsp	nsp	SAFETY STICK FOR WBT TERMINAL	STOPPER FOR SPEAKER TERMINAL
▲ L001	FN		101710069001M	# POWER TRAN FOR PM-KI-PEARL (100V)	# POWER TRANS FOR PM-KI-PEARL (100V)
▲ L001	K1G		101710071004M	# POWER TRAN FOR PM-KI-PEARL (230V)	# POWER TRANS FOR PM-KI-PEARL (230V)
▲ L001	N1B	101710071004M	101710071004M	# POWER TRAN FOR PM-KI-PEARL (230V)	# POWER TRANS FOR PM-KI-PEARL (230V)
▲ L001	U1B		101710070001M	# POWER TRAN FOR PM-KI-PEARL (120V)	# POWER TRANS FOR PM-KI-PEARL (120V)
L002		nsp	nsp	FERRITE CORE TFCK-16813	FERRITE CORE TFCK-16813
L003		nsp	nsp	FERRITE CORE TFCK-16813	FERRITE CORE TFCK-16813
VD01		173010007005M	173010007005M	LCD MODULE FOR PM-15S2	DP-0010 LCD FOR PM-15S2
W028		nsp	00MYU14100520	JD04 TO JD01	14P P1.0
PACKING					
001T	FN		541110236016M	USER MANUAL F	USER MANUAL PM-13S2 (F)
001T	K1G		541110236054M	USER MANUAL K	USER MANUAL PM-13S2 (K)
001T	N1B	541110236030M	541110236030M	USER MANUAL N/U	USER MANUAL PM-KI-PEARL (N/U) 28AJ
001T	U1B		541110236030M	USER MANUAL N/U	USER MANUAL PM-KI-PEARL (N/U) 28AJ
▲ W001	FN		00D2062141002	# AC CORD FOR JAPAN	AC CORD W/CON&PLUG
▲ W001	K1G		00D2062249001	# AC CORD FOR CHAINA	AC CORD (E1C)
▲ W001	N1B	00MZC01803080	00MZC01803080	# AC CORD FOR EUROPE	# 2P AC CORD 10A 250V CLASS2
▲ W001	U1B		00MZC01802100	# AC CORD FOR USA	# AC CORDSET 125V13A UL/CSA
Z001		00MZK340J0020	00MZK340J0020	REMOTE COMANDER RC001PM	REMOTE COMANDER RC001PM

NOTE : "nsp" PART IS LISTED FOR REFERENCE ONLY, D&M WILL NOT SUPPLY THESE PARTS.

POS. NO.	VERS. COLOR	PART NO. (FOR EUR)	PART NO. (MJ)	PART NAME	DESCRIPTION
NOT STANDARD SPARE PARTS					
001S	FN		531210101006M	PACKING CASE	PACKING CASE PM-13S2 28AJ
001S	K1G		531210101006M	PACKING CASE	PACKING CASE PM-13S2 28AJ
001S	N1B	531210078007M	531210078007M	PACKING CASE	PACKING CASE PM-KI-PEARL 28AJ
001S	U1B		531210078007M	PACKING CASE	PACKING CASE PM-KI-PEARL 28AJ
002S	N1B	531210079000M	531210079000M	MASTER CARTON	MASTER CARTON PM-KI-PEARL 28AJ
003S		00M31AK809010	00M31AK809010	CUSHION L SIDE	CUSHION (L)
004S		00M31AK809020	00M31AK809020	CUSHION R SIDE	CUSHION (R)

NOTE : "nsp" PART IS LISTED FOR REFERENCE ONLY, D&M WILL NOT SUPPLY THESE PARTS.

12. MICROPROCESSOR AND IC DATA

PD01 / QU01 : H8/3687

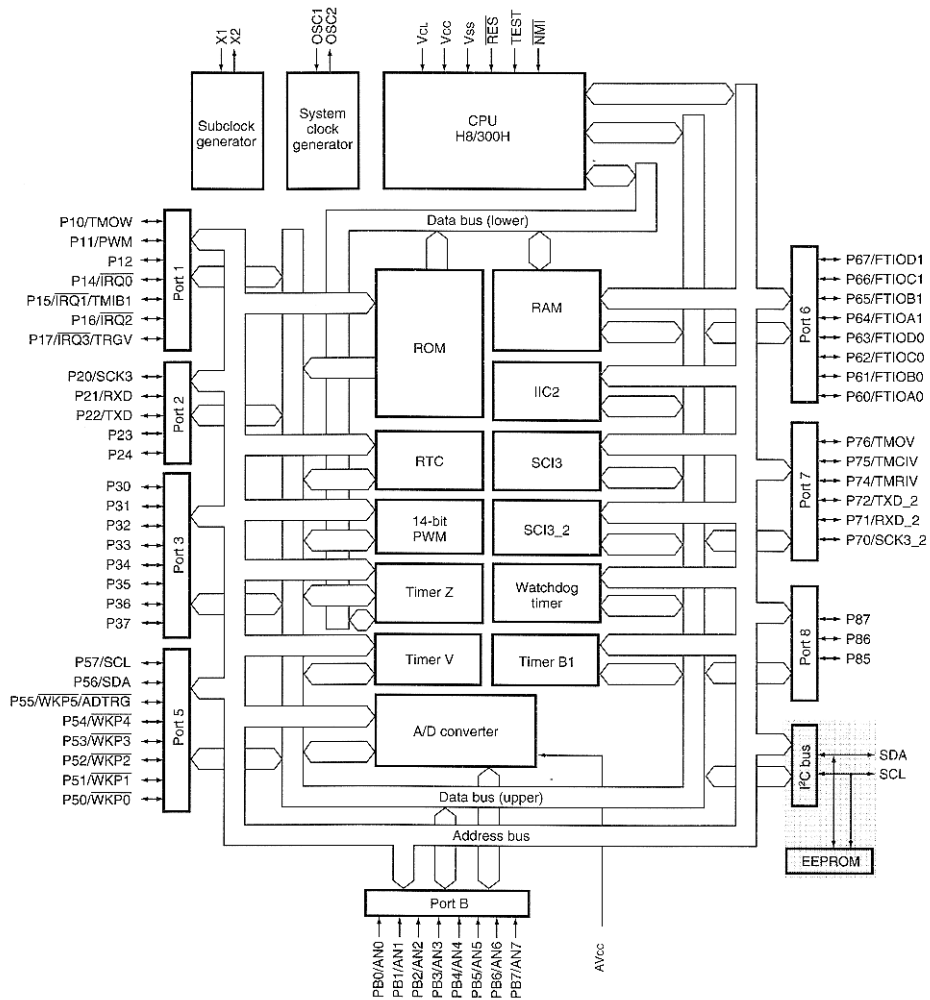
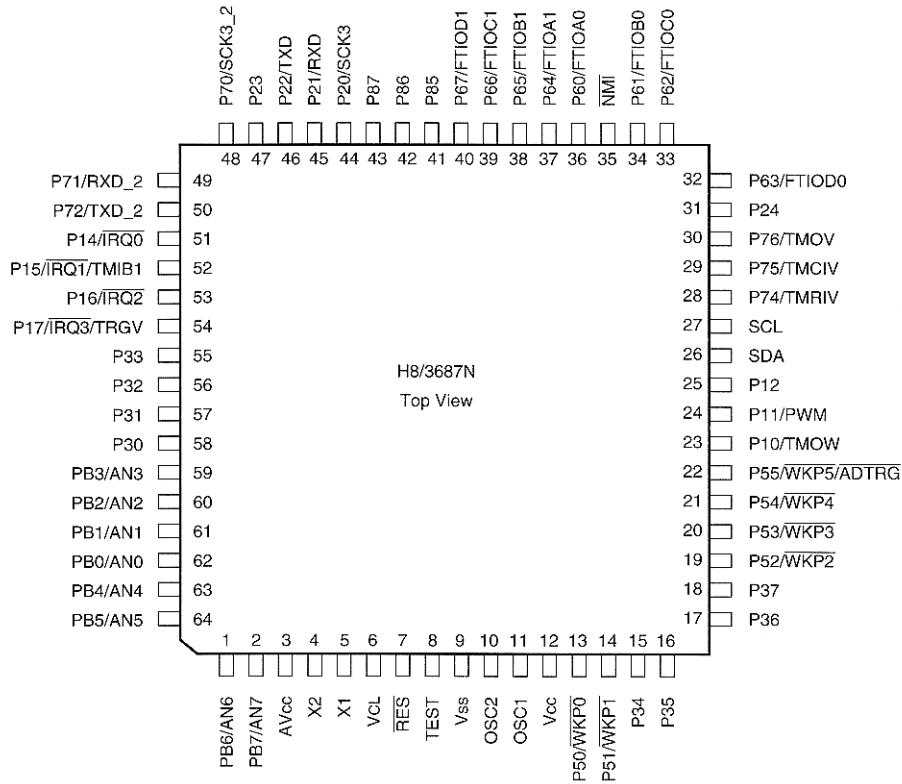

PD01 /QU01:H8/3687

Pin	PORT	SIGNAL NAME	I/O	Functions	Description
1	PB6_AN6	AD2	I	Left key A/D pin	
2	PB7_AN7	AD1	I	Model select	
3	AVcc	AVCC	I	Analog power supply	
4	X2	X1	I		NC
5	X1	X2	I		NC
6	VCL	VC1	I	Internal step-down power supply	
7	/RES	RES	I	Reset pin	
8	TEST	TEST	I	Test pin	Connect to GND
9	Vss	GND	I	GND	
10	OSC2	OSC2	O	Main clock output	
11	OSC1	OSC1	I	Main clock input	8MHz
12	Vcc	VCC	I	+3.3V Power supply	
13	P50_WKPO	VOL_A	I	Volume A	External trigger(Active H)
14	P51_WKPP1	VOL_B	I	Volume B	External trigger(Active H)
15	P34	RSV_1	I		NC
16	P35	S_CE	O	Function Select (Analog SW, LC78212) CS	
17	P36	S_DATA	O	Function Select (Analog SW, LC78212) Data	
18	P37	S_CLK	O	Function Select (Analog SW, LC78212) Clock	
19	P52_WKPP2	SEL_A	I	Rotary_encoder INPUT SELECT A	External trigger(Active H)
20	P53_WKPP3	SEL_B	I	Rotary_encoder INPUT SELECT B	External trigger(Active H)
21	P54_WKPP4	MUTE	O	PRE_OUT MUTE	Active L(MUTE ON)
22	P55_WKPP5_ADTRG	AD_INT	I	Pull up	
23	P10_TMOW	MUTE_VOL	O	Electrical VOLUME(MAS6116)MUTE	Active H(MUTE ON)
24	P11_PWM	RSV_5	I		NC
25	P12	POW_1	O	Power on control	H/L = POW_ON/POW_OFF
26	P56_SDA	SDA	I/O	EEPROM(AT24C08)Serial-Data	I2C_DATA
27	P57_SCL	SCL	O	EEPROM(AT24C08)Serial-Clock	I2C_CLOCK
28	P74_TMRIV	VOL_CS	O	ElectricalVOLUME(MAS6116) CS	Active H
29	P75_TMCIV	RSV_7	I		NC
30	P76_TMOV	KILL_IR	O		NC
31	P24	RC_OUT	O		NC
32	P63_FTIOD0	L_DATA	I/O	LCD-Controller(ST7032) Serial Data Out	
33	P62_FTIOC0	BL_ON	I/O	LCD Back Light ON	H/L = ON/OFF
34	P61_FTIOB0	OPR_ON	I/O	OPERATE LED ON	H/L = ID0,ID1/ID2,ID3,ID4(ON/OFF)
35	/NMI	ICE4	I	ICE Connection	ICE Break Control
36	P60_FTIOA0	NC1	I/O		NC
37	P64_FTIOA1	RC_IN	I	IR capture input	IR capture input(Active L)
38	P65_FTIOB1	VOL_CLK	O	Erectrical VOLUME(MAS6116) Clock	
39	P66_FTIOC1	VOL_DAT	I/O	Erectrical VOLUME(MAS6116) Data	
40	P67_FTIOD1	SPK	O	Speaker relay control	H/L = SPK_ON/SPK_OFF
41	P85	ICE1	-	ICE connect pin1	
42	P86	ICE2	-	ICE connect pin2	
43	P87	ICE3	-	ICE connect pin3	
44	P20_SCK3	D_OE	O	LED+INPUT SELECTOER Control, Serial-Interface OUTPUT ENABLE	Active H
45	P21_RXD	RXD	I	SYSTEM Control bus input	
46	P22_TXD	TXD	O	SYSTEM Control bus output	
47	P23	BI	I	STEREO/Bi-AMP 切替	H/L = STEREO/Bi-AMP
48	P70_SCK3-2	D_CLK	O	LED+INPUT SELECTOER control Serial-Interface Clock	
49	P71_RXD-2	D_CE	O	LED+INPUT SELECTOER control Serial-Interface CS	Active L
50	P72_TXD-2	DATA	O	LED+INPUT SELECTOER control Serial-Interface Data	
51	P14_/IRQ0	RSV_8	I		NC
52	P15_/IRQ1_TMIB1	P_DOWN	I	Power down detect	External trigger(Active L)

Pin	PORT	SIGNAL NAME	I/O	Functions	Description
53	P16_/IRQ2	PROT_2	I	Power supply error detect	Active L(POW_OFF)
54	P17_/IRQ3_TRGV	PROT_1	I	DC/over current/Temp detect	Active L(VOL -∞)
55	P33	L_CS	O	LCD-Controler(ST7032) CE	Active L
56	P32	L_SCL	O	LCD-Controler(ST7032) Serial Clock Out	
57	P31	L_RS	O	LCD-Controler(ST7032) Register Select	H/L = Data/Instruction
58	P30	L_RES	O	LCD-Controler(ST7032) Reset	Active L(Reset)
59	PB3_AN3	TEST1	I	PCB mode setting 1	Port check 1
60	PB2_AN2	TEST2	I	PCB mode setting 2	Port check 2
61	PB1_AN1	D-SET	I	LCD-Controler(SPLC093C) mode setting	H/L 100msec, each time
62	PB0_AN0	AD3	I	Right key A/D pin	
63	PB4_AN4	HP_DET	I	Head phone jack detect (PULL UP)	Active L(Head phone jack detect)
64	PB5_AN5	NC3	I		NC

PB01 / QB21 : PC817

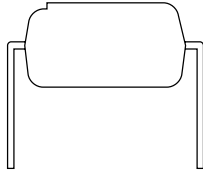
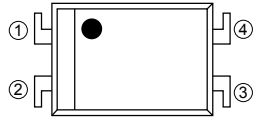
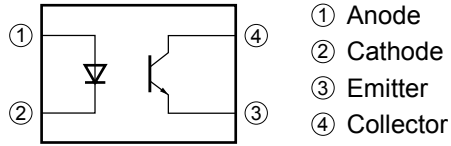

P101 / Q161 : LC78212

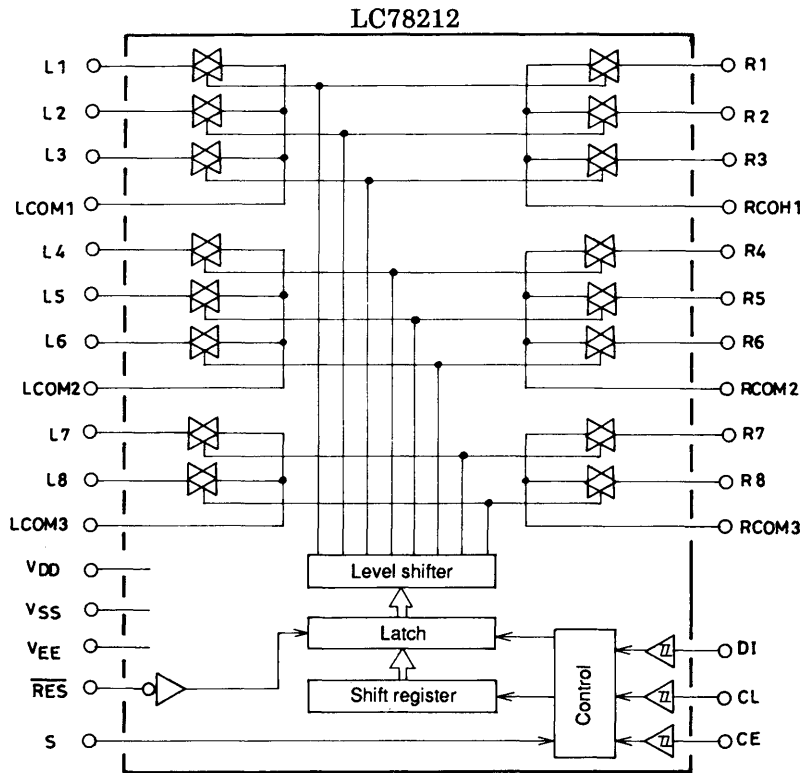

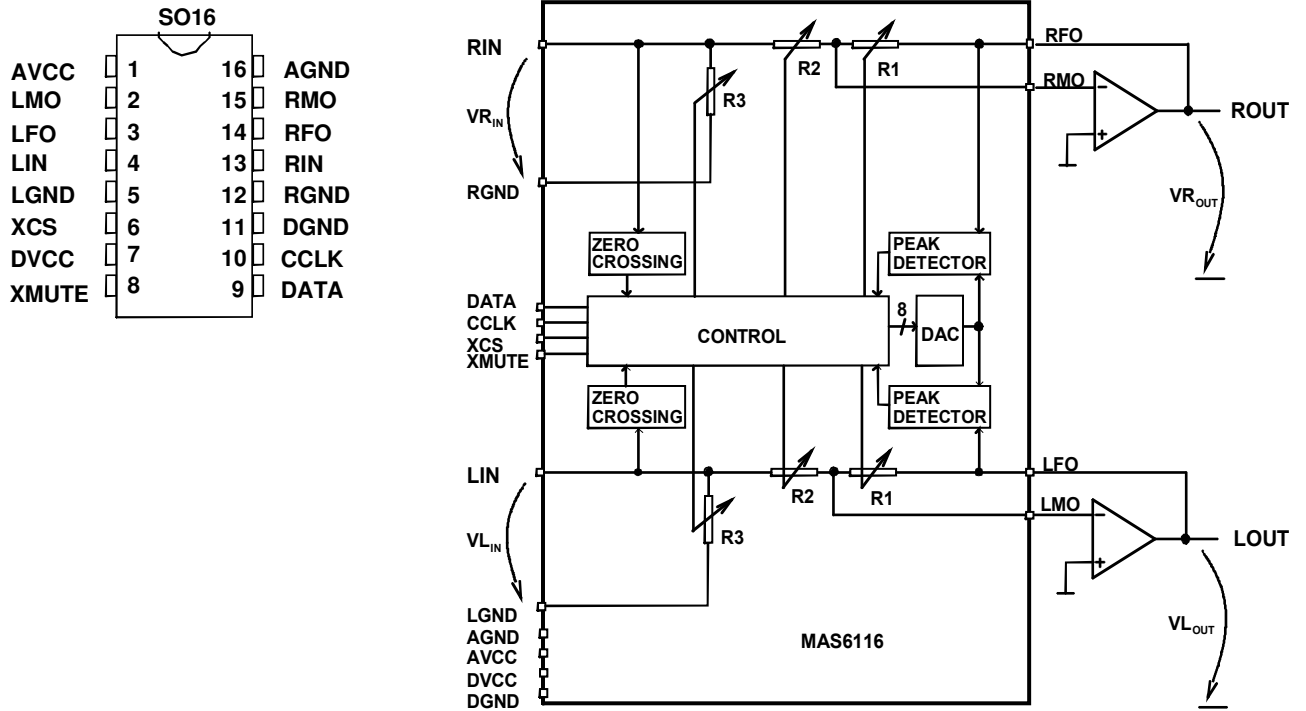

Pin Name	Pin SO16	Pin QFN 4x5	Type	Function
AVCC	1	23	P	Power Supply, for Analog
LMO	2	24	AI	External Amplifier Negative Input (Left)
LFO*	3	1	AI	Feedback Signal from External Amplifier Output (Left)
LIN*	4	3	AI	Input, Left Channel
LGND	5	4	AI	Signal Ground, Left Channel
XCS	6	7	DI	Chip Select Input of Serial Interface
DVCC	7	8	P	Power Supply, for Digital
XMUTE	8	9	DI	Mute Input
DATA	9	11	DIO	Data Input and Output of Serial Interface, Tristate
CCLK	10	12	DI	Clock Input of Serial Interface
DGND	11	13	G	Ground for Digital
RGND	12	16	AI	Signal Ground, Right Channel
RIN*	13	17	AI	Input, Right Channel
RFO*	14	19	AI	Feedback Signal from External Amplifier Output (Right)
RMO	15	20	AI	External Amplifier Negative Input (Right)
AGND	16	21	G	Ground for Analog

*) Note: These pins have limited ESD protection. See *Absolute Maximum Ratings* on page 9 for further details.

PB01 / QU02 : AT24C08

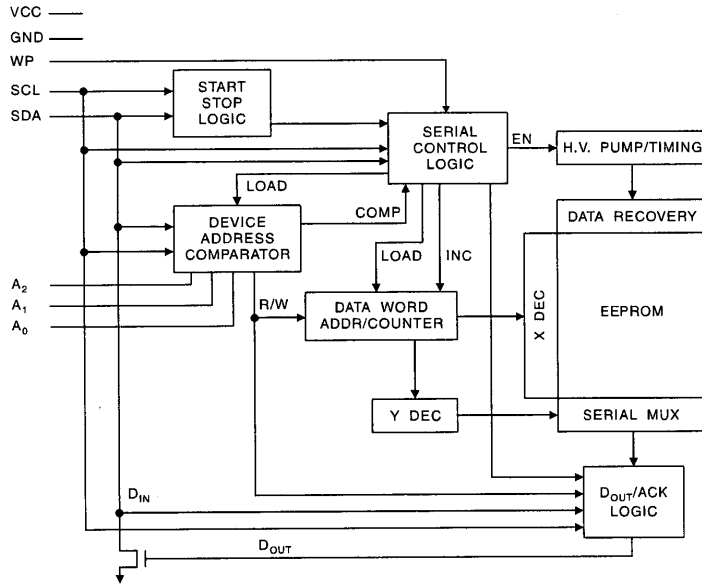
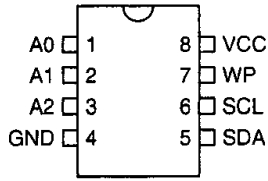

PD01 / QU03 : 74HC4094

P101 / Q181 : 74HC4094

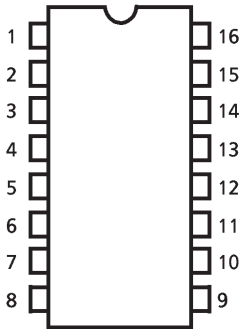

QU03		74HC4094			
Port	I/O	Name	Function	Description	
1	CE	IN	STROBE		
2	DATA	IN	DATA		
3	CLK	IN	CLOCK		
4	Q1	OUT	MC_ON	MC LED ON Active H	
5	Q2	OUT	TONE_ON	TONE LED ON Active H	
6	Q3	OUT	-	-	
7	Q4	OUT	P_DI	P.DIRECT LED ON Active H	
8	GND		GND		
9	Q5	OUT	-	-	
10	Q6	OUT	-	-	
11	Q7	OUT	-	-	
12	Q8	OUT	-	-	
13	Q9	OUT	SPK_ON	SPEAKER LED ON Active H	
14	Q10	OUT	DISP_ON	DISPLAY LED ON Active H	
15	Q11	OUT	-	-	
16	Q12	OUT	-	-	
17	OE	IN	OUTPUT ENABLE		
18	VCC		VCC		

Q181		74HC4094			
Port	I/O	Name	Function	Description	
1	CE	IN	STROBE		
2	DATA	IN	DATA		
3	CLK	IN	CLOCK		
4	Q1	OUT	MM	Phono MM relay ON Active H	
5	Q2	OUT	PH	Phono input relay ON Active H	
6	Q3	OUT	CD	CD input relay ON Active H	
7	Q4	OUT	LINE	Line input relay ON Active H	
8	GND		GND		
9	Q5	OUT	-	-	
10	Q6	OUT	-	-	
11	Q7	OUT	P_DI	Power Direct In relay ON Active H	
12	Q8	OUT	SP_O	Speaker output relay ON Active H	
13	Q9	OUT	BI	Bi-amp relay ON Active H	
14	Q10	OUT	TONE	Tone relay ON Active H	
15	Q11	OUT	-	-	
16	Q12	OUT	-	-	
17	OE	IN	OUTPUT ENABLE		
18	VCC		VCC		

13. ELECTRICAL PARTS LIST

PARTS INFORMATION

RESISTORS

- 1) 00MGD05 × × × 140, Carbon film fixed resistor, ±5% 1/4W
 2) 00MGD05 × × × 160, Carbon film fixed resistor, ±5% 1/6W

① — Resistance value

Examples ;

- ① Resistance value
 0.1Ω 001 10Ω 100 1kΩ 102 100kΩ 104
 0.5Ω 005 18Ω 180 2.7kΩ 272 680kΩ 684
 1Ω 010 100Ω 101 10kΩ 103 1MΩ 105
 6.8Ω 068 390Ω 391 22kΩ 223 4.7MΩ 475

Note : Please distinguish 1/4W from 1/6W by the shape of parts used actually.

CAPACITORS

CERAMIC CAP.

- 3) 00MDD1 × × × × 370, Ceramic capacitor
 Disc type
 Temp.coeff.P350 ~ N1000, 50V
- ② — Tolerance
 ③ — Capacity value
 — Tolerance

Examples ;

- ② Tolerance (Capacity deviation)
 ±0.25pF 0
 ±0.5pF 1
 ±5% 5

* Tolerance of COMMON PARTS handled here are as follows :

- 0.5pF ~ 5pF ±0.25pF
 6pF ~ 10pF ±0.5pF
 12pF ~ 560pF ±5%

③ Capacity value

- 0.5pF 005 3pF 030 100pF 101
 1pF 010 10pF 100 220pF 221
 1.5pF 015 47pF 470 560pF 561

CERAMIC CAP.

- 4) 00MDK16 × × × 300, High dielectric constant ceramic capacitor
 Disc type
 Temp.chara. 2B4, 50V
- ④ — Capacity value

Examples ;

- ④ Capacity value
 100pF 101 1000pF 102 10000pF 103
 470pF 471 2200pF 222

ELECTROLY CAP. ($\frac{\square}{\square}$)

- 5) 00MEA × × × × × 10, Electrolytic capacitor
 One-way lead type, Tolerance ±20%
- ⑤ — Capacity value
 ⑥ — Working voltage

Examples ;

- ⑤ Capacity value
 0.1μF 104 4.7μF 475 100μF ... 107
 0.33μF 334 10μF 106 330μF ... 337
 1μF 105 22μF 226 1100μF ... 118
 2200μF ... 228
- ⑥ Working voltage
 6.3V 006 25V 025
 10V 010 35V 035
 16V 016 50V 050

FILM CAP. ($\frac{\square}{\square}$)

- 6) 00MDF15 × × × 350 Plastic film capacitor
 One-way type, Mylar ±5% 50V
 00MDF15 × × × 310 Plastic film capacitor
 One-way type, Mylar ±10% 50V
 00MDF16 × × × 310 Plastic film capacitor
 One-way type, Mylar ±10% 50V
- ⑦ — Capacity value

Examples ;

- ⑦ Capacity value
 0.001μF (1000pF) 102 0.1μF 104
 0.0018μF 182 0.56μF 564
 0.01μF 103 1μF 105
 0.015μF 153

NOTE ON SAFETY FOR FUSIBLE RESISTOR :

The suppliers and their type numbers of fusible resistors are as follows;

1. KOA Corporation

- | | | |
|-------------------|----------------------|-------------|
| Part No. (MJI) | Type No. (KOA) | Description |
| 00MNH05 × × × 140 | → RF25S × × × × ΩJ | (±5% 1/4W) |
| 00MNH05 × × × 120 | → RF50S × × × × ΩJ | (±5% 1/2W) |
| 00MNH85 × × × 110 | → RF73B2A × × × × ΩJ | (±5% 1/10W) |
| 00MNH95 × × × 140 | → RF73B2E × × × × ΩJ | (±5% 1/4W) |
- * Resistance value Resistance value (0.1 – 10kΩ)

2. Matsushita Electronic Components Co., Ltd

- | | | |
|-------------------|------------------|-------------|
| Part No. (MJI) | Type No. (MEC) | Description |
| 00MNF05 × × × 140 | → ERD-2FCJ × × × | (±5% 1/4W) |
| 00MRF05 × × × 140 | → ERD-2FCG × × × | (±2% 1/4W) |
| 00MNF02 × × × 140 | → ERD-2FCG × × × | (±2% 1/4W) |
| 00MRF02 × × × 140 | → ERD-2FCG × × × | (±2% 1/4W) |
- * Resistance value * Resistance value

Examples ;

- * Resistance value
 0.1Ω 001 10Ω 100 1kΩ 102 100kΩ 104
 0.5Ω 005 18Ω 180 2.7kΩ 272 680kΩ 684
 1Ω 010 100Ω 101 10kΩ 103 1MΩ 105
 6.8Ω 068 390Ω 391 22kΩ 223 4.7MΩ 475

ABBREVIATION AND MARKS

ANT. : ANTENNA	BATT. : BATTERY
CAP. : CAPACITOR	CER. : CERAMIC
CONN. : CONNECTING	DIG. : DIGITAL
HP : HEADPHONE	MIC. : MICROPHONE
μ-PRO : MICROPROCESSOR	REC. : RECORDING
RES. : RESISTOR	SPK : SPEAKER
SW : SWITCH	TRANSF. : TRANSFORMER
TRIM. : TRIMMING	TRS. : TRANSISTOR
VAR. : VARIABLE	X'TAL : CRYSTAL

NOTE ON FUSE :

Regarding to all parts of parts code **00MFS20xxx2xx**, replace only with Wickmann-Werke GmbH, Type 372 non glass type fuse.

NOTE ON SAFETY :

Symbol **⚠** Fire or electrical shock hazard. Only original parts should be used to replaced any part marked with symbol **⚠**. Any other component substitution (other than original type), may increase risk of fire or electrical shock hazard.

安全上の注意 :

⚠がついている部品は、安全上重要な部品です。必ず指定されている部品番号の部品を使用して下さい。

PCB NAME	POS. NO.	VERS. COLOR	PART NO. (FOR EUR)	PART NO. (MJI)	PART NAME	DESCRIPTION
					HDAM-SA3 PWB(00MWG22AJ501-)	
5501	DN01		00MHZ20014990	00MHZ20014990		KDS122 TAPING
5501	DN02		00MHZ20014990	00MHZ20014990		KDS122 TAPING
5501	DN03		00MHZ20014990	00MHZ20014990		KDS122 TAPING
5501	DN04		00MHZ20014990	00MHZ20014990		KDS122 TAPING
5501	JN01		00MYP07005670	00MYP07005670		IMSA-6065B-06Z065-PT1
5501	QN01		00D2710320900	00D2710320900		KTA1517-GR-RTK/P
5501	QN02		00D2730481900	00D2730481900		KTC3911S-GR-RTK/P
5501	QN03		00D2710320900	00D2710320900		KTA1517-GR-RTK/P
5501	QN04		00D2730481900	00D2730481900		KTC3911S-GR-RTK/P
5501	QN05		00D2730481900	00D2730481900		KTC3911S-GR-RTK/P
5501	QN06		00D2710320900	00D2710320900		KTA1517-GR-RTK/P
5501	QN07		00D2730481900	00D2730481900		KTC3911S-GR-RTK/P
5501	QN08		00D2710320900	00D2710320900		KTA1517-GR-RTK/P
5501	RN01		00MGM114100G0	00MGM114100G0		10 OHM +-1% 1/4W
5501	RN02		00MGM114100G0	00MGM114100G0		10 OHM +-1% 1/4W
5501	RN03		nsp	00MNN05561610		560 OHM +- 5% 1/16W
5501	RN04		nsp	00MNN05561610		560 OHM +- 5% 1/16W
5501	RN05		00MGM114100G0	00MGM114100G0		10 OHM +-1% 1/4W
5501	RN06		00MGM114100G0	00MGM114100G0		10 OHM +-1% 1/4W
5501	RN07		nsp	00MNN05393610		39K OHM +- 5% 1/16W
5501	RN08		nsp	00MNN05393610		39K OHM +- 5% 1/16W
					PRE AMP PWB(00MWA27AJ101-)	
P101	C103	K1G	00MOF15101540	00MOF15101540	100PF J 100V APSV	100PF J 100V APSV
P101	C103	N1B	00MOF15101540	00MOF15101540	100PF J 100V APSV	100PF J 100V APSV
P101	C104	K1G	00MOF15101540	00MOF15101540	100PF J 100V APSV	100PF J 100V APSV
P101	C104	N1B	00MOF15101540	00MOF15101540	100PF J 100V APSV	100PF J 100V APSV
P101	C107	K1G	00MOF15101540	00MOF15101540	100PF J 100V APSV	100PF J 100V APSV
P101	C107	N1B	00MOF15101540	00MOF15101540	100PF J 100V APSV	100PF J 100V APSV
P101	C108	K1G	00MOF15101540	00MOF15101540	100PF J 100V APSV	100PF J 100V APSV
P101	C108	N1B	00MOF15101540	00MOF15101540	100PF J 100V APSV	100PF J 100V APSV
P101	C111	K1G	00MOF15101540	00MOF15101540	100PF J 100V APSV	100PF J 100V APSV
P101	C111	N1B	00MOF15101540	00MOF15101540	100PF J 100V APSV	100PF J 100V APSV
P101	C112	K1G	00MOF15101540	00MOF15101540	100PF J 100V APSV	100PF J 100V APSV
P101	C112	N1B	00MOF15101540	00MOF15101540	100PF J 100V APSV	100PF J 100V APSV
P101	C115	K1G	00MOF15101540	00MOF15101540	100PF J 100V APSV	100PF J 100V APSV
P101	C115	N1B	00MOF15101540	00MOF15101540	100PF J 100V APSV	100PF J 100V APSV
P101	C116	K1G	00MOF15101540	00MOF15101540	100PF J 100V APSV	100PF J 100V APSV
P101	C116	N1B	00MOF15101540	00MOF15101540	100PF J 100V APSV	100PF J 100V APSV
P101	C119	K1G	00MOF15101540	00MOF15101540	100PF J 100V APSV	100PF J 100V APSV
P101	C119	N1B	00MOF15101540	00MOF15101540	100PF J 100V APSV	100PF J 100V APSV
P101	C120	K1G	00MOF15101540	00MOF15101540	100PF J 100V APSV	100PF J 100V APSV
P101	C120	N1B	00MOF15101540	00MOF15101540	100PF J 100V APSV	100PF J 100V APSV
P101	C123	K1G	00MOF15101540	00MOF15101540	100PF J 100V APSV	100PF J 100V APSV
P101	C123	N1B	00MOF15101540	00MOF15101540	100PF J 100V APSV	100PF J 100V APSV
P101	C124	K1G	00MOF15101540	00MOF15101540	100PF J 100V APSV	100PF J 100V APSV
P101	C124	N1B	00MOF15101540	00MOF15101540	100PF J 100V APSV	100PF J 100V APSV
P101	C141		00MOA106035Z0	00MOA106035Z0	ROS-35V 100M - F3#PE - T2 (10UF 35V)	ROS-35V 100M - F3#PE - T2 (10UF 35V)
P101	C142		00MOA106035Z0	00MOA106035Z0	ROS-35V 100M - F3#PE - T2 (10UF 35V)	ROS-35V 100M - F3#PE - T2 (10UF 35V)
P101	C143		00MOF55331580	00MOF55331580	330PF 100V +- 5% FNS	330PF 100V +- 5% FNS
P101	C144		00MOF55331580	00MOF55331580	330PF 100V +- 5% FNS	330PF 100V +- 5% FNS
P101	C145		00MOA226025Z0	00MOA226025Z0	ROS-25V 220M - F3#PE - T2 (22UF 25V)	ROS-25V 220M - F3#PE - T2 (22UF 25V)
P101	C146		00MOA226025Z0	00MOA226025Z0	ROS-25V 220M - F3#PE - T2 (22UF 25V)	ROS-25V 220M - F3#PE - T2 (22UF 25V)
P101	C147		00MOA227025R0	00MOA227025R0	ROA-25V 221M -H5#PE - T2 (220UF 25V)	ROA-25V 221M -H5#PE - T2 (220UF 25V)
P101	C148		00MOA227025R0	00MOA227025R0	ROA-25V 221M -H5#PE - T2 (220UF 25V)	ROA-25V 221M -H5#PE - T2 (220UF 25V)
P101	C161		00MOA106050Z0	00MOA106050Z0	10 UF M 50V RA-2	10 UF M 50V RA-2
P101	C163		00MOA227025R0	00MOA227025R0	ROA-25V 221M (220UF 25V)	ROA-25V 221M -H5#PE - T2 (220UF 25V)
P101	C164		00MOA227025R0	00MOA227025R0	ROA-25V 221M (220UF 25V)	ROA-25V 221M -H5#PE - T2 (220UF 25V)
P101	C165		00MOA106050Z0	00MOA106050Z0	10 UF M 50V RA-2	10 UF M 50V RA-2
P101	C166		00MOA106050Z0	00MOA106050Z0	10 UF M 50V RA-2	10 UF M 50V RA-2
P101	C167		00MOA106035Z0	00MOA106035Z0	ROS-35V 100M - F3#PE - T2 (10UF 35V)	ROS-35V 100M - F3#PE - T2 (10UF 35V)
P101	C168		00MOA106035Z0	00MOA106035Z0	ROS-35V 100M - F3#PE - T2 (10UF 35V)	ROS-35V 100M - F3#PE - T2 (10UF 35V)
P101	C201		00MOA106035Z0	00MOA106035Z0	ROS-35V 100M - F3#PE - T2 (10UF 35V)	ROS-35V 100M - F3#PE - T2 (10UF 35V)
P101	C202		00MOA106035Z0	00MOA106035Z0	ROS-35V 100M - F3#PE - T2 (10UF 35V)	ROS-35V 100M - F3#PE - T2 (10UF 35V)

NOTE : "nsp" PART IS LISTED FOR REFERENCE ONLY, D&M WILL NOT SUPPLY THESE PARTS.

PCB NAME	POS. NO.	VERS. COLOR	PART NO. (FOR EUR)	PART NO. (MJI)	PART NAME	DESCRIPTION
P101	C203		00MOF15101540	00MOF15101540	100PF J 100V APSV	100PF J 100V APSV
P101	C204		00MOF15101540	00MOF15101540	100PF J 100V APSV	100PF J 100V APSV
P101	C205		00MOF15101540	00MOF15101540	100PF J 100V APSV	100PF J 100V APSV
P101	C206		00MOF15101540	00MOF15101540	100PF J 100V APSV	100PF J 100V APSV
P101	C207		00MOA226025Z0	00MOA226025Z0	ROS-25V 220M - F3#PE - T2 (22UF 25V)	ROS-25V 220M - F3#PE - T2 (22UF 25V)
P101	C208		00MOA226025Z0	00MOA226025Z0	ROS-25V 220M - F3#PE - T2 (22UF 25V)	ROS-25V 220M - F3#PE - T2 (22UF 25V)
P101	C209		00MOA227025R0	00MOA227025R0	ROA-25V 221M -H5#PE - T2 (220UF 25V)	ROA-25V 221M -H5#PE - T2 (220UF 25V)
P101	C210		00MOA227025R0	00MOA227025R0	ROA-25V 221M -H5#PE - T2 (220UF 25V)	ROA-25V 221M -H5#PE - T2 (220UF 25V)
P101	C321		00MOA106035Z0	00MOA106035Z0	ROS-35V 100M - F3#PE - T2 (10UF 35V)	ROS-35V 100M - F3#PE - T2 (10UF 35V)
P101	C322		00MOA106035Z0	00MOA106035Z0	ROS-35V 100M - F3#PE - T2 (10UF 35V)	ROS-35V 100M - F3#PE - T2 (10UF 35V)
P101	C323		00MOA106035Z0	00MOA106035Z0	ROS-35V 100M - F3#PE - T2 (10UF 35V)	ROS-35V 100M - F3#PE - T2 (10UF 35V)
P101	C324		00MOA106035Z0	00MOA106035Z0	ROS-35V 100M - F3#PE - T2 (10UF 35V)	ROS-35V 100M - F3#PE - T2 (10UF 35V)
P101	C325		00MOA227025R0	00MOA227025R0	ROA-25V 221M (220UF 25V)	ROA-25V 221M -H5#PE - T2 (220UF 25V)
P101	C326		00MOA227025R0	00MOA227025R0	ROA-25V 221M (220UF 25V)	ROA-25V 221M -H5#PE - T2 (220UF 25V)
P101	C351		00MOA106035Z0	00MOA106035Z0	ROS-35V 100M - F3#PE - T2 (10UF 35V)	ROS-35V 100M - F3#PE - T2 (10UF 35V)
P101	C352		00MOA106035Z0	00MOA106035Z0	ROS-35V 100M - F3#PE - T2 (10UF 35V)	ROS-35V 100M - F3#PE - T2 (10UF 35V)
P101	C353		00MOF15331540	00MOF15331540	APSV 331J,330PF(TP) 100V PP	APSV 331J,330PF(TP) 100V PP
P101	C354		00MOF15331540	00MOF15331540	APSV 331J,330PF(TP) 100V PP	APSV 331J,330PF(TP) 100V PP
P101	C355		00MOA106035Z0	00MOA106035Z0	ROS-35V 100M - F3#PE - T2 (10UF 35V)	ROS-35V 100M - F3#PE - T2 (10UF 35V)
P101	C356		00MOA106035Z0	00MOA106035Z0	ROS-35V 100M - F3#PE - T2 (10UF 35V)	ROS-35V 100M - F3#PE - T2 (10UF 35V)
P101	C501		00MOA227025R0	00MOA227025R0	ROA-25V 221M -H5#PE - T2 (220UF 25V)	ROA-25V 221M -H5#PE - T2 (220UF 25V)
P101	C502		00MOA227025R0	00MOA227025R0	ROA-25V 221M -H5#PE - T2 (220UF 25V)	ROA-25V 221M -H5#PE - T2 (220UF 25V)
P101	C507		00MOA226025Z0	00MOA226025Z0	ROS-25V 220M - F3#PE - T2 (22UF 25V)	ROS-25V 220M - F3#PE - T2 (22UF 25V)
P101	C508		00MOA226025Z0	00MOA226025Z0	ROS-25V 220M - F3#PE - T2 (22UF 25V)	ROS-25V 220M - F3#PE - T2 (22UF 25V)
P101	C509		00MOA226025Z0	00MOA226025Z0	ROS-25V 220M - F3#PE - T2 (22UF 25V)	ROS-25V 220M - F3#PE - T2 (22UF 25V)
P101	C510		00MOA226025Z0	00MOA226025Z0	ROS-25V 220M - F3#PE - T2 (22UF 25V)	ROS-25V 220M - F3#PE - T2 (22UF 25V)
P101	C511		00MOA226025Z0	00MOA226025Z0	ROS-25V 220M - F3#PE - T2 (22UF 25V)	ROS-25V 220M - F3#PE - T2 (22UF 25V)
P101	C512		00MOA226025Z0	00MOA226025Z0	ROS-25V 220M - F3#PE - T2 (22UF 25V)	ROS-25V 220M - F3#PE - T2 (22UF 25V)
P101	C513		00MOF56681540	00MOF56681540	STAR(126)100VDC681J7-10	STAR(126)100VDC681J7-10
P101	C514		00MOF56681540	00MOF56681540	STAR(126)100VDC681J7-10	STAR(126)100VDC681J7-10
P101	C515		00MOA227025R0	00MOA227025R0	ROA-25V 221M -H5#PE - T2 (220UF 25V)	ROA-25V 221M -H5#PE - T2 (220UF 25V)
P101	C516		00MOA227025R0	00MOA227025R0	ROA-25V 221M -H5#PE - T2 (220UF 25V)	ROA-25V 221M -H5#PE - T2 (220UF 25V)
P101	C517		00MOA227025R0	00MOA227025R0	ROA-25V 221M -H5#PE - T2 (220UF 25V)	ROA-25V 221M -H5#PE - T2 (220UF 25V)
P101	C518		00MOA227025R0	00MOA227025R0	ROA-25V 221M -H5#PE - T2 (220UF 25V)	ROA-25V 221M -H5#PE - T2 (220UF 25V)
P101	C519		00MOA227025R0	00MOA227025R0	ROA-25V 221M -H5#PE - T2 (220UF 25V)	ROA-25V 221M -H5#PE - T2 (220UF 25V)
P101	C520		00MOA227025R0	00MOA227025R0	ROA-25V 221M -H5#PE - T2 (220UF 25V)	ROA-25V 221M -H5#PE - T2 (220UF 25V)
P101	C521		00MOA227025R0	00MOA227025R0	ROA-25V 221M -H5#PE - T2 (220UF 25V)	ROA-25V 221M -H5#PE - T2 (220UF 25V)
P101	C522		00MOA227025R0	00MOA227025R0	ROA-25V 221M -H5#PE - T2 (220UF 25V)	ROA-25V 221M -H5#PE - T2 (220UF 25V)
P101	C523		00MOF56331540	00MOF56331540	STAR(126)100VDC331J7-10	STAR(126)100VDC331J7-10
P101	C524		00MOF56331540	00MOF56331540	STAR(126)100VDC331J7-10	STAR(126)100VDC331J7-10
P101	C525		00MOA226025Z0	00MOA226025Z0	ROS-25V 220M - F3#PE - T2 (22UF 25V)	ROS-25V 220M - F3#PE - T2 (22UF 25V)
P101	C526		00MOA226025Z0	00MOA226025Z0	ROS-25V 220M - F3#PE - T2 (22UF 25V)	ROS-25V 220M - F3#PE - T2 (22UF 25V)
P101	C872		00MOA227025R0	00MOA227025R0	ROA-25V 221M -H5#PE - T2 (220UF 25V)	ROA-25V 221M -H5#PE - T2 (220UF 25V)
P101	C873		00MOA225100Z1	00MOA225100Z1	ROS-35V 100M - F3#PE - T2 (10UF 35V)	ROS-100V2R2 F3#PE-T2
P101	C874		00MOA225100Z1	00MOA225100Z1	ROS-35V 100M - F3#PE - T2 (10UF 35V)	ROS-100V2R2 F3#PE-T2
P101	C875		00MOA227025R0	00MOA227025R0	ROA-25V 221M -H5#PE - T2 (220UF 25V)	ROA-25V 221M -H5#PE - T2 (220UF 25V)
P101	C876		00MOA227025R0	00MOA227025R0	ROA-25V 221M -H5#PE - T2 (220UF 25V)	ROA-25V 221M -H5#PE - T2 (220UF 25V)
P101	C877		00MOA227025R0	00MOA227025R0	ROA-25V 221M -H5#PE - T2 (220UF 25V)	ROA-25V 221M -H5#PE - T2 (220UF 25V)
P101	C878		00MOA227025R0	00MOA227025R0	ROA-25V 221M -H5#PE - T2 (220UF 25V)	ROA-25V 221M -H5#PE - T2 (220UF 25V)
P101	C879		00MOA106035Z0	00MOA106035Z0	ROS-35V 100M - F3#PE - T2 (10UF 35V)	ROS-35V 100M - F3#PE - T2 (10UF 35V)
P101	D131		00MHD20002000	00MHD20002000	1SS133 T-77	1SS133 T-77
P101	D132		00MHD20002000	00MHD20002000	1SS133 T-77	1SS133 T-77
P101	D133		00MHD20002000	00MHD20002000	1SS133 T-77	1SS133 T-77
P101	D134		00MHD20002000	00MHD20002000	1SS133 T-77	1SS133 T-77
P101	D161		00MHD20002000	00MHD20002000	1SS133 T-77	1SS133 T-77
P101	D201		00MHD20002000	00MHD20002000	1SS133 T-77	1SS133 T-77
P101	D301		00MHD20002000	00MHD20002000	1SS133 T-77	1SS133 T-77
P101	D351		00MHD20002000	00MHD20002000	1SS133 T-77	1SS133 T-77
P101	D501		00MHD20002000	00MHD20002000	1SS133 T-77	1SS133 T-77
P101	D871		00MHD30561000	00MHD30561000	5.6V ZENER EQUIVALENT	5.6V ZENER EQUIVALENT
P101	D872		00MHD20002000	00MHD20002000	1SS133 T-77	1SS133 T-77
P101	D873		00MHD20002000	00MHD20002000	1SS133 T-77	1SS133 T-77
P101	D874		00MHD32401000	00MHD32401000	24V ZENER EQUIVALENT	24V ZENER EQUIVALENT
P101	D875		00MHD32401000	00MHD32401000	24V ZENER EQUIVALENT	24V ZENER EQUIVALENT
P101	J101		00MYT02041330	00MYT02041330	YKC21-3601V 2L4P FG BK AU	YKC21-3601V 2L4P FG BK AU

NOTE : "nsp" PART IS LISTED FOR REFERENCE ONLY, D&M WILL NOT SUPPLY THESE PARTS.

PCB NAME	POS. NO.	VERS. COLOR	PART NO. (FOR EUR)	PART NO. (MJJ)	PART NAME	DESCRIPTION
P101	J102		00MYT02041330	00MYT02041330	YKC21-3601V 2L4P FG BK AU	YKC21-3601V 2L4P FG BK AU
P101	J103		00MYT02041330	00MYT02041330	YKC21-3601V 2L4P FG BK AU	YKC21-3601V 2L4P FG BK AU
P101	J104		00MYJ06006280	00MYJ06006280	B8B-PH-K-S (LF)(SN)	B8B-PH-K-S (LF)(SN)
P101	J105		00MYP0600391X	00MYP0600391X	B4B-EH-TS (LF)(SN) 4P RADIAL TAPING	B4B-EH-TS (LF)(SN) 4P RADIAL TAPING
P101	J181		00MYJ06006330	00MYJ06006330	B13B-PH-K-S (LF)(SN)	B13B-PH-K-S (LF)(SN)
P101	J201		00MYJ06006280	00MYJ06006280	B8B-PH-K-S (LF)(SN)	B8B-PH-K-S (LF)(SN)
P101	J301		00MYP06003830	00MYP06003830	B3B-EH-TS (LF)(SN) 3P RADIAL TAPING	B3B-EH-TS (LF)(SN) 3P RADIAL TAPING
P101	J302		00MYP06003850	00MYP06003850	B2B-EH	B2B-EH
P101	J321		00MYP06003840	00MYP06003840	B6B-EH-TS (LF)(SN) 6P RADIAL TAPING JST	B6B-EH-TS (LF)(SN) 6P RADIAL TAPING JST
P101	J871		00MYP06010450	00MYP06010450	B5B-EH-TS (LF)(SN) 5P RADIAL TAPING	B5B-EH-TS (LF)(SN) 5P RADIAL TAPING
P101	L131		00D2140208003	00D2140208003	RELAY(NA24W-K)	RELAY(NA24W-K)
P101	L132		00D2140208003	00D2140208003	RELAY(NA24W-K)	RELAY(NA24W-K)
P101	L133		00D2140208003	00D2140208003	RELAY(NA24W-K)	RELAY(NA24W-K)
P101	L134		00D2140208003	00D2140208003	RELAY(NA24W-K)	RELAY(NA24W-K)
P101	L201		00D2140208003	00D2140208003	RELAY(NA24W-K)	RELAY(NA24W-K)
P101	L202		00D2140208003	00D2140208003	RELAY(NA24W-K)	RELAY(NA24W-K)
P101	L301		00D2140208003	00D2140208003	RELAY(NA24W-K)	RELAY(NA24W-K)
P101	L321		00D2140208003	00D2140208003	RELAY(NA24W-K)	RELAY(NA24W-K)
P101	L351		00D2140208003	00D2140208003	RELAY(NA24W-K)	RELAY(NA24W-K)
P101	Q131		00D2690206908	00D2690206908	KRC102M	KRC102M-AT/P (10K-10K)
P101	Q132		00D2690206908	00D2690206908	KRC102M	KRC102M-AT/P (10K-10K)
P101	Q133		00D2690206908	00D2690206908	KRC102M	KRC102M-AT/P (10K-10K)
P101	Q134		00D2690206908	00D2690206908	KRC102M	KRC102M-AT/P (10K-10K)
P101	Q135		00D2690206908	00D2690206908	KRC102M	KRC102M-AT/P (10K-10K)
P101	Q141		00MKH27AJ1010	00MKH27AJ1010	HSAM-SA2D	HDAM-SA2D
P101	Q142		00MKH27AJ1010	00MKH27AJ1010	HSAM-SA2D	HDAM-SA2D
P101	Q161		00MHC10309030	00MHC10309030	LC78212	IC LC78212:CMOS LOGIC SANYO
P101	Q162		00MHC10053090	00MHC10053090	NJM2068DD	IC NJM2068DD:MONO ANA SHINNIHON MUSEN
P101	Q163		00D2690206908	00D2690206908	KRC102M	KRC102M-AT/P (10K-10K)
P101	Q164		00D2690206908	00D2690206908	KRC102M	KRC102M-AT/P (10K-10K)
P101	Q166		00D2690206908	00D2690206908	KRC102M	KRC102M-AT/P (10K-10K)
P101	Q181		00MHC709449B0	00MHC709449B0	74HC4094	74HC4094 16PIN DIP PHILIPS
P101	Q201		00D2690206908	00D2690206908	KRC102M	KRC102M-AT/P (10K-10K)
P101	Q202		00MHC10053090	00MHC10053090	NJM2068DD	IC NJM2068DD:MONO ANA SHINNIHON MUSEN
P101	Q301		00D2690206908	00D2690206908	KRC102M	KRC102M-AT/P (10K-10K)
P101	Q321		00MHC10053090	00MHC10053090	NJM2068DD	IC NJM2068DD:MONO ANA SHINNIHON MUSEN
P101	Q352		00MHC10053090	00MHC10053090	NJM2068DD	IC NJM2068DD:MONO ANA SHINNIHON MUSEN
P101	Q361		00D2690206908	00D2690206908	KRC102M	KRC102M-AT/P (10K-10K)
P101	Q501		235010024700S	235010024700S	MAS6116 VOLUME CONTROL IC	MAS6116 VOLUME CONTROL IC
P101	Q503		00MKH27AJ1010	00MKH27AJ1010	HSAM-SA2D	HDAM-SA2D
P101	Q504		00MKH27AJ1010	00MKH27AJ1010	HSAM-SA2D	HDAM-SA2D
P101	Q505		00MKH22AJ1010	00MKH22AJ1010	HDAM-SA3	HDAM-SA3
P101	Q506		00MKH22AJ1010	00MKH22AJ1010	HDAM-SA3	HDAM-SA3
P101	Q507		00MHT600121A0	00MHT600121A0	KTA1268	KTA1268 PNP TRANSISTOR RANK=GR
P101	Q508		00MHT600121A0	00MHT600121A0	KTA1268	KTA1268 PNP TRANSISTOR RANK=GR
P101	Q509		00MHT800931A0	00MHT800931A0	KTC3200	KTC3200 NPN TRANSISTOR RANK=GR
P101	Q510		00MHT800931A0	00MHT800931A0	KTC3200	KTC3200 NPN TRANSISTOR RANK=GR
P101	Q511		00MHT600121A0	00MHT600121A0	KTA1268	KTA1268 PNP TRANSISTOR RANK=GR
P101	Q512		00MHT600121A0	00MHT600121A0	KTA1268	KTA1268 PNP TRANSISTOR RANK=GR
P101	Q513		00MHT600121A0	00MHT600121A0	KTA1268	KTA1268 PNP TRANSISTOR RANK=GR
P101	Q514		00MHT600121A0	00MHT600121A0	KTA1268	KTA1268 PNP TRANSISTOR RANK=GR
P101	Q515		00MHT800931A0	00MHT800931A0	KTC3200	KTC3200 NPN TRANSISTOR RANK=GR
P101	Q516		00MHT800931A0	00MHT800931A0	KTC3200	KTC3200 NPN TRANSISTOR RANK=GR
P101	Q517		00MHT800931A0	00MHT800931A0	KTC3200	KTC3200 NPN TRANSISTOR RANK=GR
P101	Q518		00MHT800931A0	00MHT800931A0	KTC3200	KTC3200 NPN TRANSISTOR RANK=GR
P101	Q519		00MKH27AJ1010	00MKH27AJ1010	HSAM-SA2D	HDAM-SA2D
P101	Q520		00MKH27AJ1010	00MKH27AJ1010	HSAM-SA2D	HDAM-SA2D
P101	Q521		00MKH22AJ1010	00MKH22AJ1010	HDAM-SA3	HDAM-SA3
P101	Q522		00MKH22AJ1010	00MKH22AJ1010	HDAM-SA3	HDAM-SA3
P101	Q523		00MHT600121A0	00MHT600121A0	KTA1268	KTA1268 PNP TRANSISTOR RANK=GR
P101	Q524		00MHT600121A0	00MHT600121A0	KTA1268	KTA1268 PNP TRANSISTOR RANK=GR

NOTE : "nsp" PART IS LISTED FOR REFERENCE ONLY, D&M WILL NOT SUPPLY THESE PARTS.

PCB NAME	POS. NO.	VERS. COLOR	PART NO. (FOR EUR)	PART NO. (MJI)	PART NAME	DESCRIPTION
P101	Q525		00MHT800931A0	00MHT800931A0	KTC3200	KTC3200 NPN TRANSISTOR RANK=GR
P101	Q526		00MHT800931A0	00MHT800931A0	KTC3200	KTC3200 NPN TRANSISTOR RANK=GR
P101	Q527		00MHT600121A0	00MHT600121A0	KTA1268	KTA1268 PNP TRANSISTOR RANK=GR
P101	Q528		00MHT600121A0	00MHT600121A0	KTA1268	KTA1268 PNP TRANSISTOR RANK=GR
P101	Q529		00MHT600121A0	00MHT600121A0	KTA1268	KTA1268 PNP TRANSISTOR RANK=GR
P101	Q530		00MHT600121A0	00MHT600121A0	KTA1268	KTA1268 PNP TRANSISTOR RANK=GR
P101	Q531		00MHT800931A0	00MHT800931A0	KTC3200	KTC3200 NPN TRANSISTOR RANK=GR
P101	Q532		00MHT800931A0	00MHT800931A0	KTC3200	KTC3200 NPN TRANSISTOR RANK=GR
P101	Q533		00MHT800931A0	00MHT800931A0	KTC3200	KTC3200 NPN TRANSISTOR RANK=GR
P101	Q534		00MHT800931A0	00MHT800931A0	KTC3200	KTC3200 NPN TRANSISTOR RANK=GR
P101	Q535		00MKH27AJ1010	00MKH27AJ1010	HSAM-SA2D	HDAM-SA2D
P101	Q536		00MKH27AJ1010	00MKH27AJ1010	HSAM-SA2D	HDAM-SA2D
P101	Q871		00MHT800931A0	00MHT800931A0	KTC3200	KTC3200 NPN TRANSISTOR RANK=GR
P101	Q872		00D2710311906	00D2710311906	KTA1267	KTA1267-GR-AT/P
P101	Q873		00D2730468907	00D2730468907	KTC3199	KTC3199-GR-AT/P
P101	▲ Q874		00MHT41415100	00MHT41415100	! TRANSISTOR 2SD1415	TRANSISTOR 2SD1415
P101	▲ Q875		00MHT21020100	00MHT21020100	! 2SB1020	2SB1020
P101	▲ R153		00MGG05100160	00MGG05100160	! 10 OHM +- 5% 1/6W	10 OHM +- 5% 1/6W
P101	▲ R154		00MGG05100160	00MGG05100160	! 10 OHM +- 5% 1/6W	10 OHM +- 5% 1/6W
P101	R167		00MGG05681160	00MGG05681160	680 OHM +- 5% 1/6W	680 OHM +- 5% 1/6W
P101	R168		00MGG05681160	00MGG05681160	680 OHM +- 5% 1/6W	680 OHM +- 5% 1/6W
P101	R215		00MGG05471160	00MGG05471160	470 OHM +- 5% 1/6W	470 OHM +- 5% 1/6W
P101	R216		00MGG05471160	00MGG05471160	470 OHM +- 5% 1/6W	470 OHM +- 5% 1/6W
P101	R329		00MGG05681160	00MGG05681160	680 OHM +- 5% 1/6W	680 OHM +- 5% 1/6W
P101	R330		00MGG05681160	00MGG05681160	680 OHM +- 5% 1/6W	680 OHM +- 5% 1/6W
P101	▲ R501		00MGG05220160	00MGG05220160	! 22 OHM +- 5% 1/6W	22 OHM +- 5% 1/6W
P101	▲ R557		00MGG05100160	00MGG05100160	! 10 OHM +- 5% 1/6W	10 OHM +- 5% 1/6W
P101	▲ R558		00MGG05100160	00MGG05100160	! 10 OHM +- 5% 1/6W	10 OHM +- 5% 1/6W
P101	▲ R559		00MGG05100160	00MGG05100160	! 10 OHM +- 5% 1/6W	10 OHM +- 5% 1/6W
P101	▲ R560		00MGG05100160	00MGG05100160	! 10 OHM +- 5% 1/6W	10 OHM +- 5% 1/6W
P101	R872		00MGG05222160	00MGG05222160	2.2K OHM +- 5% 1/6W	2.2K OHM +- 5% 1/6W
P101	▲ R882		00MGG05047160	00MGG05047160	! 4.7 OHM +- 5% 1/6W	4.7 OHM +- 5% 1/6W
P101	▲ R883		00MGG05047160	00MGG05047160	! 4.7 OHM +- 5% 1/6W	4.7 OHM +- 5% 1/6W
					TONE PWB(00MWG27AJ307-)	
P251	C251		00MOA22505020	00MOA22505020	2.2 UF M 50V RA-2	2.2 UF M 50V RA-2
P251	C252		00MOA22505020	00MOA22505020	2.2 UF M 50V RA-2	2.2 UF M 50V RA-2
P251	C253		00MOF15683040	00MOF15683040	0.068UF +-5% 50V MTFV	0.068UF +-5% 50V MTFV
P251	C254		00MOF15683040	00MOF15683040	0.068UF +-5% 50V MTFV	0.068UF +-5% 50V MTFV
P251	C255		00MOF15103540	00MOF15103540	APSV 103J 0.01UF(TP) 100V PP	APSV 103J 0.01UF(TP) 100V PP
P251	C256		00MOF15103540	00MOF15103540	APSV 103J 0.01UF(TP) 100V PP	APSV 103J 0.01UF(TP) 100V PP
P251	C257		00MOF15101540	00MOF15101540	100PF J 100V APSV	100PF J 100V APSV
P251	C258		00MOF15101540	00MOF15101540	100PF J 100V APSV	100PF J 100V APSV
P251	C259		00MOA10702520	00MOA10702520	100 UF M 25V RA-2	100 UF M 25V RA-2
P251	C260		00MOA10702520	00MOA10702520	100 UF M 25V RA-2	100 UF M 25V RA-2
P251	C261		00MOA10702520	00MOA10702520	100 UF M 25V RA-2	100 UF M 25V RA-2
P251	C262		00MOA10702520	00MOA10702520	100 UF M 25V RA-2	100 UF M 25V RA-2
P251	J251		00MYJ06006280	00MYJ06006280	B8B-PH-K-S (LF)(SN)	B8B-PH-K-S (LF)(SN)
P251	Q251		00MHC10053090	00MHC10053090	IC NJM2068DD:MONO ANA SHINNIHON MUSEN	IC NJM2068DD:MONO ANA SHINNIHON MUSEN
P251	Q252		00MHC10053090	00MHC10053090	IC NJM2068DD:MONO ANA SHINNIHON MUSEN	IC NJM2068DD:MONO ANA SHINNIHON MUSEN
P251	R251		00MRM01031280	00MRM01031280	10K(B)X2 K09G0A0C	10K(B)X2 K09G0A0C
P251	R252		00MRM01031280	00MRM01031280	10K(B)X2 K09G0A0C	10K(B)X2 K09G0A0C
P251	R253		nsp	00MNN05122610	1.2K OHM +- 5% 1/16W	1.2K OHM +- 5% 1/16W
P251	R254		nsp	00MNN05122610	1.2K OHM +- 5% 1/16W	1.2K OHM +- 5% 1/16W
P251	R255		nsp	00MNN05563610	56K OHM +- 5% 1/16W	56K OHM +- 5% 1/16W
P251	R256		nsp	00MNN05563610	56K OHM +- 5% 1/16W	56K OHM +- 5% 1/16W
P251	R257		nsp	00MNN05122610	1.2K OHM +- 5% 1/16W	1.2K OHM +- 5% 1/16W
P251	R258		nsp	00MNN05122610	1.2K OHM +- 5% 1/16W	1.2K OHM +- 5% 1/16W
P251	R259		nsp	00MNN05563610	56K OHM +- 5% 1/16W	56K OHM +- 5% 1/16W
P251	R260		nsp	00MNN05563610	56K OHM +- 5% 1/16W	56K OHM +- 5% 1/16W

NOTE : "nsp" PART IS LISTED FOR REFERENCE ONLY, D&M WILL NOT SUPPLY THESE PARTS.

PCB NAME	POS. NO.	VERS. COLOR	PART NO. (FOR EUR)	PART NO. (MJI)	PART NAME	DESCRIPTION
					PRE OUT PWB(00MWA27AJ102-)	
P351	C371	K1G	00MOF15101540	00MOF15101540	100PF J 100V APSV	100PF J 100V APSV
P351	C371	N1B	00MOF15101540	00MOF15101540	100PF J 100V APSV	100PF J 100V APSV
P351	C372	K1G	00MOF15101540	00MOF15101540	100PF J 100V APSV	100PF J 100V APSV
P351	C372	N1B	00MOF15101540	00MOF15101540	100PF J 100V APSV	100PF J 100V APSV
P351	C373	K1G	00MOF15101540	00MOF15101540	100PF J 100V APSV	100PF J 100V APSV
P351	C373	N1B	00MOF15101540	00MOF15101540	100PF J 100V APSV	100PF J 100V APSV
P351	C374	K1G	00MOF15101540	00MOF15101540	100PF J 100V APSV	100PF J 100V APSV
P351	C374	N1B	00MOF15101540	00MOF15101540	100PF J 100V APSV	100PF J 100V APSV
P351	J371		00MYT02041330	00MYT02041330	YKC21-3601V 2L4P FG BK AU	YKC21-3601V 2L4P FG BK AU
P351	J372		00MYP06003840	00MYP06003840	B6B-EH-TS (LF)(SN) 6P RADIAL TAPING JST	B6B-EH-TS (LF)(SN) 6P RADIAL TAPING JST
					PHONO AMP/CD PWB(00MWA27AJ203-)	
P401	C403		00MOF55102580	00MOF55102580	1000PF 100V FNS	1000PF 100V FNS
P401	C404		00MOF55102580	00MOF55102580	1000PF 100V FNS	1000PF 100V FNS
P401	C405		00MOA106035Z0	00MOA106035Z0	ROS-35V 100M - F3#PE - T2 (10UF 35V)	ROS-35V 100M - F3#PE - T2 (10UF 35V)
P401	C406		00MOA106035Z0	00MOA106035Z0	ROS-35V 100M - F3#PE - T2 (10UF 35V)	ROS-35V 100M - F3#PE - T2 (10UF 35V)
P401	C407	FN	00MOF55101590	00MOF55101590	100PF 200V +- 5% FAS	100PF 200V +- 5% FAS
P401	C407	K1G	00MOF55221590	00MOF55221590	220PF 200V +- 5% FAS	220PF 200V +- 5% FAS
P401	C407	N1B	00MOF55221590	00MOF55221590	220PF 200V +- 5% FAS	220PF 200V +- 5% FAS
P401	C407	U1B	00MOF55101590	00MOF55101590	100PF 200V +- 5% FAS	100PF 200V +- 5% FAS
P401	C408	FN	00MOF55101590	00MOF55101590	100PF 200V +- 5% FAS	100PF 200V +- 5% FAS
P401	C408	K1G	00MOF55221590	00MOF55221590	220PF 200V +- 5% FAS	220PF 200V +- 5% FAS
P401	C408	N1B	00MOF55221590	00MOF55221590	220PF 200V +- 5% FAS	220PF 200V +- 5% FAS
P401	C408	U1B	00MOF55101590	00MOF55101590	100PF 200V +- 5% FAS	100PF 200V +- 5% FAS
P401	C409		00MOA47801046	00MOA47801046	RFO-10V472MJ6P#-S1	RFO-10V472MJ6P#-S1
P401	C410		00MOA47801046	00MOA47801046	RFO-10V472MJ6P#-S1	RFO-10V472MJ6P#-S1
P401	C411		00MOF55393580	00MOF55393580	0.039UF 100V +- 5% FAS	0.039UF 100V +- 5% FAS
P401	C412		00MOF55393580	00MOF55393580	0.039UF 100V +- 5% FAS	0.039UF 100V +- 5% FAS
P401	C413		00MOF55332581	00MOF55332581	3300PF 100V FNS	3300PF 100V FNS
P401	C414		00MOF55332581	00MOF55332581	3300PF 100V FNS	3300PF 100V FNS
P401	C415		00MOF55681580	00MOF55681580	680PF 100V +-5% FNS	680PF 100V +-5% FNS
P401	C416		00MOF55681580	00MOF55681580	680PF 100V +-5% FNS	680PF 100V +-5% FNS
P401	C417		00MOF55103580	00MOF55103580	0.01UF 100V +- 5% FNS	0.01UF 100V +- 5% FNS
P401	C418		00MOF55103580	00MOF55103580	0.01UF 100V +- 5% FNS	0.01UF 100V +- 5% FNS
P401	C419		00MOF55102580	00MOF55102580	1000PF 100V FNS	1000PF 100V FNS
P401	C420		00MOF55102580	00MOF55102580	1000PF 100V FNS	1000PF 100V FNS
P401	C421		00MOA47801046	00MOA47801046	RFO-10V472MJ6P#-S1	RFO-10V472MJ6P#-S1
P401	C422		00MOA47801046	00MOA47801046	RFO-10V472MJ6P#-S1	RFO-10V472MJ6P#-S1
P401	C423		00MOA225100Z1	00MOA225100Z1	ROS-100V2R2 F3#PE-T2	ROS-100V2R2 F3#PE-T2
P401	C424		00MOA225100Z1	00MOA225100Z1	ROS-100V2R2 F3#PE-T2	ROS-100V2R2 F3#PE-T2
P401	C427		00MOA227025R0	00MOA227025R0	ROA-25V 221M -H5#PE - T2 (220UF 25V)	ROA-25V 221M -H5#PE - T2 (220UF 25V)
P401	C428		00MOA227025R0	00MOA227025R0	ROA-25V 221M -H5#PE - T2 (220UF 25V)	ROA-25V 221M -H5#PE - T2 (220UF 25V)
P401	C429		00MOA227025R0	00MOA227025R0	ROA-25V 221M -H5#PE - T2 (220UF 25V)	ROA-25V 221M -H5#PE - T2 (220UF 25V)
P401	C430		00MOA227025R0	00MOA227025R0	ROA-25V 221M -H5#PE - T2 (220UF 25V)	ROA-25V 221M -H5#PE - T2 (220UF 25V)
P401	C431		00MOA225100Z1	00MOA225100Z1	ROS-100V2R2 F3#PE-T2	ROS-100V2R2 F3#PE-T2
P401	C433	K1G	00MOA227025R0	00MOF55101590	100PF 200V +- 5% FAS	100PF 200V +- 5% FAS
P401	C433	N1B	00MOA227025R0	00MOF55101590	100PF 200V +- 5% FAS	100PF 200V +- 5% FAS
P401	C434	K1G	00MOA227025R0	00MOF55101590	100PF 200V +- 5% FAS	100PF 200V +- 5% FAS
P401	C434	N1B	00MOA227025R0	00MOF55101590	100PF 200V +- 5% FAS	100PF 200V +- 5% FAS
P401	C435	K1G	00MOF55103580	00MOF55103580	0.01UF 100V +- 5% FNS	0.01UF 100V +- 5% FNS
P401	C435	N1B	00MOF55103580	00MOF55103580	0.01UF 100V +- 5% FNS	0.01UF 100V +- 5% FNS
P401	C436	K1G	00MOF55103580	00MOF55103580	0.01UF 100V +- 5% FNS	0.01UF 100V +- 5% FNS
P401	C436	N1B	00MOF55103580	00MOF55103580	0.01UF 100V +- 5% FNS	0.01UF 100V +- 5% FNS
P401	C437	K1G	00MOF55103580	00MOF55103580	0.01UF 100V +- 5% FNS	0.01UF 100V +- 5% FNS
P401	C437	N1B	00MOF55103580	00MOF55103580	0.01UF 100V +- 5% FNS	0.01UF 100V +- 5% FNS
P401	C438	K1G	00MOF55103580	00MOF55103580	0.01UF 100V +- 5% FNS	0.01UF 100V +- 5% FNS
P401	C438	N1B	00MOF55103580	00MOF55103580	0.01UF 100V +- 5% FNS	0.01UF 100V +- 5% FNS
P401	C483	K1G	00MOF55101590	00MOF55101590	100PF 200V +- 5% FAS	100PF 200V +- 5% FAS
P401	C483	N1B	00MOF55101590	00MOF55101590	100PF 200V +- 5% FAS	100PF 200V +- 5% FAS
P401	C484	K1G	00MOF55101590	00MOF55101590	100PF 200V +- 5% FAS	100PF 200V +- 5% FAS
P401	C484	N1B	00MOF55101590	00MOF55101590	100PF 200V +- 5% FAS	100PF 200V +- 5% FAS
P401	C485		00MOA106035Z0	00MOA106035Z0	ROS-35V 100M - F3#PE - T2 (10UF 35V)	ROS-35V 100M - F3#PE - T2 (10UF 35V)
P401	C486		00MOA106035Z0	00MOA106035Z0	ROS-35V 100M - F3#PE - T2 (10UF 35V)	ROS-35V 100M - F3#PE - T2 (10UF 35V)

NOTE : "nsp" PART IS LISTED FOR REFERENCE ONLY, D&M WILL NOT SUPPLY THESE PARTS.

PCB NAME	POS. NO.	VERS. COLOR	PART NO. (FOR EUR)	PART NO. (MJI)	PART NAME	DESCRIPTION
P401	C487		00MOF56331540	00MOF56331540	STAR(126)100VDC331J7-10	STAR(126)100VDC331J7-10
P401	C488		00MOF56331540	00MOF56331540	STAR(126)100VDC331J7-10	STAR(126)100VDC331J7-10
P401	C489		00MOA226025Z0	00MOA226025Z0	ROS-25V 220M - F3#PE - T2 (22UF 25V)	ROS-25V 220M - F3#PE - T2 (22UF 25V)
P401	C490		00MOA226025Z0	00MOA226025Z0	ROS-25V 220M - F3#PE - T2 (22UF 25V)	ROS-25V 220M - F3#PE - T2 (22UF 25V)
P401	C491		00MOA227025R0	00MOA227025R0	ROA-25V 221M -H5#PE - T2 (220UF 25V)	ROA-25V 221M -H5#PE - T2 (220UF 25V)
P401	C492		00MOA227025R0	00MOA227025R0	ROA-25V 221M -H5#PE - T2 (220UF 25V)	ROA-25V 221M -H5#PE - T2 (220UF 25V)
P401	D401		00MHD20002000	00MHD20002000	1SS133 T-77	1SS133 T-77
P401	J401		00MYT02021390	00MYT02021390	2P RCA PINJACK (T6743 BLK/BLK)	2P RCA PINJACK (T6743 BLK/BLK)
P401	J402		00MYJ06006280	00MYJ06006280	B8B-PH-K-S (LF)(SN)	B8B-PH-K-S (LF)(SN)
P401	J481		00MYT02021390	00MYT02021390	2P RCA PINJACK (T6743 BLK/BLK)	2P RCA PINJACK (T6743 BLK/BLK)
P401	J482		00MYP0600391X	00MYP0600391X	B4B-EH-TS (LF)(SN) 4P RADIAL TAPING	B4B-EH-TS (LF)(SN) 4P RADIAL TAPING
P401	L401	K1G	00MLC13240010	00MLC13240010	320 MH CHOKE COIL (TOROIDAL)	320 MH CHOKE COIL (TOROIDAL)
P401	L401	N1B	00MLC13240010	00MLC13240010	320 MH CHOKE COIL (TOROIDAL)	320 MH CHOKE COIL (TOROIDAL)
P401	L402	K1G	00MLC13240010	00MLC13240010	320 MH CHOKE COIL (TOROIDAL)	320 MH CHOKE COIL (TOROIDAL)
P401	L402	N1B	00MLC13240010	00MLC13240010	320 MH CHOKE COIL (TOROIDAL)	320 MH CHOKE COIL (TOROIDAL)
P401	L403		00D2140208003	00D2140208003	RELAY(NA24W-K)	RELAY(NA24W-K)
P401	L404		00D2140208003	00D2140208003	RELAY(NA24W-K)	RELAY(NA24W-K)
P401	Q401		00MKH22AJ1010	00MKH22AJ1010	HDAM-SA3	HDAM-SA3
P401	Q402		00MKH22AJ1010	00MKH22AJ1010	HDAM-SA3	HDAM-SA3
P401	Q403		00MHT600121A0	00MHT600121A0	KTA1268 PNP TRANSISTOR RANK=GR	KTA1268 PNP TRANSISTOR RANK=GR
P401	Q404		00MHT600121A0	00MHT600121A0	KTA1268 PNP TRANSISTOR RANK=GR	KTA1268 PNP TRANSISTOR RANK=GR
P401	Q405		00MHT800931A0	00MHT800931A0	KTC3200 NPN TRANSISTOR RANK=GR	KTC3200 NPN TRANSISTOR RANK=GR
P401	Q406		00MHT800931A0	00MHT800931A0	KTC3200 NPN TRANSISTOR RANK=GR	KTC3200 NPN TRANSISTOR RANK=GR
P401	Q407		00MHT600121A0	00MHT600121A0	KTA1268 PNP TRANSISTOR RANK=GR	KTA1268 PNP TRANSISTOR RANK=GR
P401	Q408		00MHT600121A0	00MHT600121A0	KTA1268 PNP TRANSISTOR RANK=GR	KTA1268 PNP TRANSISTOR RANK=GR
P401	Q409		00MHT800931A0	00MHT800931A0	KTC3200 NPN TRANSISTOR RANK=GR	KTC3200 NPN TRANSISTOR RANK=GR
P401	Q410		00MHT800931A0	00MHT800931A0	KTC3200 NPN TRANSISTOR RANK=GR	KTC3200 NPN TRANSISTOR RANK=GR
P401	Q411		00MHT600121A0	00MHT600121A0	KTA1268 PNP TRANSISTOR RANK=GR	KTA1268 PNP TRANSISTOR RANK=GR
P401	Q412		00MHT600121A0	00MHT600121A0	KTA1268 PNP TRANSISTOR RANK=GR	KTA1268 PNP TRANSISTOR RANK=GR
P401	Q413		00MHT800931A0	00MHT800931A0	KTC3200 NPN TRANSISTOR RANK=GR	KTC3200 NPN TRANSISTOR RANK=GR
P401	Q414		00MHT800931A0	00MHT800931A0	KTC3200 NPN TRANSISTOR RANK=GR	KTC3200 NPN TRANSISTOR RANK=GR
P401	Q415		00MKH27AJ1010	00MKH27AJ1010	HDAM-SA2D	HDAM-SA2D
P401	Q416		00MKH27AJ1010	00MKH27AJ1010	HDAM-SA2D	HDAM-SA2D
P401	Q417		00MKH27AJ1010	00MKH27AJ1010	HDAM-SA2D	HDAM-SA2D
P401	Q418		00MKH27AJ1010	00MKH27AJ1010	HDAM-SA2D	HDAM-SA2D
P401	Q481		00MKH27AJ1010	00MKH27AJ1010	HDAM-SA2D	HDAM-SA2D
P401	Q482		00MKH27AJ1010	00MKH27AJ1010	HDAM-SA2D	HDAM-SA2D
P401	▲ R493		00MGG05100160	00MGG05100160	! 10 OHM +- 5% 1/6W	10 OHM +- 5% 1/6W
P401	▲ R494		00MGG05100160	00MGG05100160	! 10 OHM +- 5% 1/6W	10 OHM +- 5% 1/6W
					LCH POWER AMP PWB(00MWA27AJ201-)	
P601	C601		00MOA106035Z0	00MOA106035Z0	ROS-35V 100M - F3#PE - T2 (10UF 35V)	ROS-35V 100M - F3#PE - T2 (10UF 35V)
P601	C602		00MOB47708050	00MOB47708050	470UF/80V NICHICON PB-FREE	470UF/80V NICHICON PB-FREE
P601	C603		00MOB47708050	00MOB47708050	470UF/80V NICHICON PB-FREE	470UF/80V NICHICON PB-FREE
P601	C605		00MOA225100Z1	00MOA225100Z1	ROS-100V2R2 F3#PE-T2	ROS-100V2R2 F3#PE-T2
P601	C606		00MOA225100Z1	00MOA225100Z1	ROS-100V2R2 F3#PE-T2	ROS-100V2R2 F3#PE-T2
P601	C607		00MOF56681540	00MOF56681540	STAR(126)100VDC681J7-10	STAR(126)100VDC681J7-10
P601	C608		00MOA107025Z0	00MOA107025Z0	ROS-25V 101M - H4#PE - T2 (100UF 25V)	ROS-25V 101M - H4#PE - T2 (100UF 25V)
P601	C609		00MOA227025R0	00MOA227025R0	ROA-25V 221M -H5#PE - T2 (220UF 25V)	ROA-25V 221M -H5#PE - T2 (220UF 25V)
P601	C610		00MOF55103580	00MOF55103580	0.01UF 100V +- 5% FNS	0.01UF 100V +- 5% FNS
P601	C611		00MOA47405020	00MOA47405020	0.47UF M 50V RA-2	0.47UF M 50V RA-2
P601	D601		00MHD20002000	00MHD20002000	1SS133 T-77	1SS133 T-77
P601	D602		00MHD20002000	00MHD20002000	1SS133 T-77	1SS133 T-77
P601	D603		00MHD20002000	00MHD20002000	1SS133 T-77	1SS133 T-77
P601	D604		00MHD20002000	00MHD20002000	1SS133 T-77	1SS133 T-77
P601	D605		00MHD20002000	00MHD20002000	1SS133 T-77	1SS133 T-77
P601	D606		00MHD20002000	00MHD20002000	1SS133 T-77	1SS133 T-77
P601	D607		00MHD20002000	00MHD20002000	1SS133 T-77	1SS133 T-77
P601	D608		00MHD20002000	00MHD20002000	1SS133 T-77	1SS133 T-77
P601	D609		00MHD20002000	00MHD20002000	1SS133 T-77	1SS133 T-77
P601	D610		00MHD20002000	00MHD20002000	1SS133 T-77	1SS133 T-77
P601	D611		00MHD20002000	00MHD20002000	1SS133 T-77	1SS133 T-77
P601	D612		00MHD20002000	00MHD20002000	1SS133 T-77	1SS133 T-77
P601	D613		00MHD20002000	00MHD20002000	1SS133 T-77	1SS133 T-77
P601	D614		00MHD20002000	00MHD20002000	1SS133 T-77	1SS133 T-77

NOTE : "hsp" PART IS LISTED FOR REFERENCE ONLY, D&M WILL NOT SUPPLY THESE PARTS.

PCB NAME	POS. NO.	VERS. COLOR	PART NO. (FOR EUR)	PART NO. (MJJ)	PART NAME	DESCRIPTION
P601	D615		00MHD20002000	00MHD20002000	1SS133 T-77	1SS133 T-77
P601	D616		00MHD20002000	00MHD20002000	1SS133 T-77	1SS133 T-77
P601	D618		00MHD20027010	00MHD20027010	HSS81TD-E 150V 150MA AXIAL TAPG.	HSS81TD-E 150V 150MA AXIAL TAPG.
P601	D619		00MHD20027010	00MHD20027010	HSS81TD-E 150V 150MA AXIAL TAPG.	HSS81TD-E 150V 150MA AXIAL TAPG.
P601	J601		00MYP06003830	00MYP06003830	B3B-EH-TS (LF)(SN) 3P RADIAL TAPING	B3B-EH-TS (LF)(SN) 3P RADIAL TAPING
P601	J605		00MYP06003830	00MYP06003830	B3B-EH-TS (LF)(SN) 3P RADIAL TAPING	B3B-EH-TS (LF)(SN) 3P RADIAL TAPING
P601	J606		00MYJ06006220	00MYJ06006220	B2B-PH-K-S (LF)(SN)	B2B-PH-K-S (LF)(SN)
P601	J607		00MYP07005670	00MYP07005670	IMSA-6065B-06Z065-PT1	IMSA-6065B-06Z065-PT1
P601	J608		00MYP07005670	00MYP07005670	IMSA-6065B-06Z065-PT1	IMSA-6065B-06Z065-PT1
P601	J609		00MYP06003830	00MYP06003830	B3B-EH-TS (LF)(SN) 3P RADIAL TAPING	B3B-EH-TS (LF)(SN) 3P RADIAL TAPING
P601	▲ KT61		00MHK185919C0	00MHK185919C0	! 2SA1859/C4883 O/O OR Y/Y PAIR	2SA1859/C4883 O/O OR Y/Y PAIR
P601	Q601		00MHT600121A0	00MHT600121A0	KTA1268 PNP TRANSISTOR RANK=GR	KTA1268 PNP TRANSISTOR RANK=GR
P601	Q602		00MKH27AJ1010	00MKH27AJ1010	HDAM-SA2D	HDAM-SA2D
P601	Q603		00MHT800931A0	00MHT800931A0	KTC3200 NPN TRANSISTOR RANK=GR	KTC3200 NPN TRANSISTOR RANK=GR
P601	Q604		00MHT800931A0	00MHT800931A0	KTC3200 NPN TRANSISTOR RANK=GR	KTC3200 NPN TRANSISTOR RANK=GR
P601	Q605		00MHT600121A0	00MHT600121A0	KTA1268 PNP TRANSISTOR RANK=GR	KTA1268 PNP TRANSISTOR RANK=GR
P601	Q606		00MHT600121A0	00MHT600121A0	KTA1268 PNP TRANSISTOR RANK=GR	KTA1268 PNP TRANSISTOR RANK=GR
P601	Q607		00MHT800931A0	00MHT800931A0	KTC3200 NPN TRANSISTOR RANK=GR	KTC3200 NPN TRANSISTOR RANK=GR
P601	Q608		00MHT600121A0	00MHT600121A0	KTA1268 PNP TRANSISTOR RANK=GR	KTA1268 PNP TRANSISTOR RANK=GR
P601	Q609		00MHT111452A0	00MHT111452A0	2SA1145 O OR Y	2SA1145 O OR Y TAPING TOSHIBA
P601	Q610		00MHT327052A0	00MHT327052A0	2SC2705 O OR Y	2SC2705 O OR Y TAPING TOSHIBA
P601	Q611		00MHT800931A0	00MHT800931A0	KTC3200 NPN TRANSISTOR RANK=GR	KTC3200 NPN TRANSISTOR RANK=GR
P601	Q612		00MHT800931A0	00MHT800931A0	KTC3200 NPN TRANSISTOR RANK=GR	KTC3200 NPN TRANSISTOR RANK=GR
P601	Q613		00MHT600121A0	00MHT600121A0	KTA1268 PNP TRANSISTOR RANK=GR	KTA1268 PNP TRANSISTOR RANK=GR
P601	Q614		00MHT600121A0	00MHT600121A0	KTA1268 PNP TRANSISTOR RANK=GR	KTA1268 PNP TRANSISTOR RANK=GR
P601	Q615		00MKH27AJ1010	00MKH27AJ1010	HDAM-SA2D	HDAM-SA2D
P601	Q616		00MHT800931A0	00MHT800931A0	KTC3200 NPN TRANSISTOR RANK=GR	KTC3200 NPN TRANSISTOR RANK=GR
P601	▲ Q617		00MHT334191Y0	00MHT334191Y0	! 2SC3419	TRANSISTOR C3419 Y 40V 0.8A PC=1.2W (5W)
P601	Q618		00MHT327052A0	00MHT327052A0	2SC2705 O OR Y	2SC2705 O OR Y TAPING TOSHIBA
P601	Q619		00MHT111452A0	00MHT111452A0	2SA1145 O OR Y	2SA1145 O OR Y TAPING TOSHIBA
P601	▲ Q620		00MHT348832A0	00MHT348832A0	! TRANSISTOR 2SC4883 O OR Y	TRANSISTOR 2SC4883 O OR Y
P601	▲ Q621		00MHT118592A0	00MHT118592A0	! TRANSISTOR 2SA1859 O OR Y	TRANSISTOR 2SA1859 O OR Y
P601	▲ KT06		00MHK130319A0	00MHK130319A0	! 2SA1303/2SC3284 (O P OR Y)PAIR	2SA1303/2SC3284 (O P OR Y)PAIR
P601	▲ Q622		00MHT332843A0	00MHT332843A0	! 2SC3284 (O P OR Y) PC=125W	2SC3284 (O P OR Y) PC=125W
P601	▲ Q623		00MHT113033A0	00MHT113033A0	! 2SA1303 (O P OR Y) PC=125W	TRANSISTOR 2SA1303 (O P OR Y) PC=125W
P601	Q624		00MHT800931A0	00MHT800931A0	KTC3200 NPN TRANSISTOR RANK=GR	KTC3200 NPN TRANSISTOR RANK=GR
P601	Q625		00MHT600121A0	00MHT600121A0	KTA1268 PNP TRANSISTOR RANK=GR	KTA1268 PNP TRANSISTOR RANK=GR
P601	R602		00MGM11410030	00MGM11410030	100K OHM +-1% 1/4W	100K OHM +-1% 1/4W
P601	R603		00MGM11422620	00MGM11422620	22.6K OHM +- 1% 1/4W	22.6K OHM +- 1% 1/4W
P601	R604		00MGM11410000	00MGM11410000	100 OHM +-1% 1/4W	100 OHM +-1% 1/4W
P601	R608		00MGM11410000	00MGM11410000	100 OHM +-1% 1/4W	100 OHM +-1% 1/4W
P601	▲ R609		00MGG05471160	00MGG05471160	470 OHM +- 5% 1/6W	470 OHM +- 5% 1/6W
P601	▲ R610		00MGG05471160	00MGG05471160	470 OHM +- 5% 1/6W	470 OHM +- 5% 1/6W
P601	▲ R611		00MGG05151160	00MGG05151160	! 150 OHM +- 5% 1/6W	150 OHM +- 5% 1/6W
P601	R612		00MGM11410041	00MGM11410041	1M OHM +-1% 1/4W	1M OHM +-1% 1/4W
P601	R613		00MGM11410041	00MGM11410041	1M OHM +-1% 1/4W	1M OHM +-1% 1/4W
P601	▲ R614		00MGG05151160	00MGG05151160	! 150 OHM +- 5% 1/6W	150 OHM +- 5% 1/6W
P601	R615		00MGA05152010	00MGA05152010	1.5K OHM +- 5% 1W	1.5K OHM +- 5% 1W
P601	R625		00MRA02220760	00MRA02220760	VARIABLE RESISTOR 2.2KOHM VERT	VARIABLE RESISTOR 2.2KOHM VERT
P601	R629		00MRA01020760	00MRA01020760	VARIABLE RESISTOR 1K VERTICAL	VARIABLE RESISTOR 1K VERTICAL
P601	▲ R631		00MGG05100140	00MGG05100140	! 10 OHM +- 5% 1/4W	10 OHM +- 5% 1/4W
P601	▲ R632		00MGG05101160	00MGG05101160	! 100 OHM +- 5% 1/6W	100 OHM +- 5% 1/6W
P601	▲ R633		00MGG05101160	00MGG05101160	! 100 OHM +- 5% 1/6W	100 OHM +- 5% 1/6W
P601	▲ R634		00MGG05100140	00MGG05100140	! 10 OHM +- 5% 1/4W	10 OHM +- 5% 1/4W
P601	▲ R635		00MGG05102160	00MGG05102160	1K OHM +- 5% 1/6W	1K OHM +- 5% 1/6W
P601	▲ R636		00MGG05470160	00MGG05470160	! 47 OHM +- 5% 1/6W	47 OHM +- 5% 1/6W
P601	▲ R637		00MGG05470160	00MGG05470160	! 47 OHM +- 5% 1/6W	47 OHM +- 5% 1/6W
P601	▲ R638		00MGG05221140	00MGG05221140	! 220 OHM +- 5% 1/4W	220 OHM +- 5% 1/4W
P601	▲ R639		00MGG05100160	00MGG05100160	! 10 OHM +- 5% 1/6W	10 OHM +- 5% 1/6W
P601	▲ R640		00MGG05100160	00MGG05100160	! 10 OHM +- 5% 1/6W	10 OHM +- 5% 1/6W
P601	▲ R641		00MGO05001050	00MGO05001050	! 0.1 OHMS +-5% 5W PBR58	0.1 OHMS +-5% 5W PBR58
P601	▲ R642		00MGO05001050	00MGO05001050	! 0.1 OHMS +-5% 5W PBR58	0.1 OHMS +-5% 5W PBR58
P601	▲ R645		00MGG05102160	00MGG05102160	1K OHM +- 5% 1/6W	1K OHM +- 5% 1/6W

NOTE : "nsp" PART IS LISTED FOR REFERENCE ONLY, D&M WILL NOT SUPPLY THESE PARTS.

PCB NAME	POS. NO.	VERS. COLOR	PART NO. (FOR EUR)	PART NO. (MJI)	PART NAME	DESCRIPTION
P601	▲ R646		00MGG05102160	00MGG05102160	1K OHM +- 5% 1/6W	1K OHM +- 5% 1/6W
P601	R647		00MGG05472160	00MGG05472160	4.7K OHM +- 5% 1/6W	4.7K OHM +- 5% 1/6W
					LCH POSISTOY PWB(00MWA27AJ206-)	
P651	▲ R671	U1B	00MHP00033240	00MHP00033240	! PTH9M04BC222TS2F333	VARISTOR PTH9M04BC222TS2F333 (MURATA)
P651	▲ R672		00MHP00033240	00MHP00033240	! PTH9M04BC222TS2F333	VARISTOR PTH9M04BC222TS2F333 (MURATA)
					RCH POWER AMP PWB(00MWA27AJ202-)	
P701	C701		00MOA106035Z0	00MOA106035Z0	ROS-35V 100M - F3#PE - T2 (10UF 35V)	ROS-35V 100M - F3#PE - T2 (10UF 35V)
P701	C702		00MOB47708050	00MOB47708050	470UF/80V NICHICON PB-FREE	470UF/80V NICHICON PB-FREE
P701	C703		00MOB47708050	00MOB47708050	470UF/80V NICHICON PB-FREE	470UF/80V NICHICON PB-FREE
P701	C705		00MOA225100Z1	00MOA225100Z1	ROS-100V2R2 F3#PE-T2	ROS-100V2R2 F3#PE-T2
P701	C706		00MOA225100Z1	00MOA225100Z1	ROS-100V2R2 F3#PE-T2	ROS-100V2R2 F3#PE-T2
P701	C707		00MOF56681540	00MOF56681540	STAR(126)100VDC681J7-10	STAR(126)100VDC681J7-10
P701	C708		00MOA107025Z0	00MOA107025Z0	ROS-25V 101M - H4#PE - T2 (100UF 25V)	ROS-25V 101M - H4#PE - T2 (100UF 25V)
P701	C709		00MOA227025R0	00MOA227025R0	ROA-25V 221M -H5#PE - T2 (220UF 25V)	ROA-25V 221M -H5#PE - T2 (220UF 25V)
P701	C710		00MOF55103580	00MOF55103580	0.01UF 100V +- 5% FNS	0.01UF 100V +- 5% FNS
P701	C711		00MOA47405020	00MOA47405020	0.47UF M 50V RA-2	0.47UF M 50V RA-2
P701	D701		00MHD20002000	00MHD20002000	1SS133 T-77	1SS133 T-77
P701	D702		00MHD20002000	00MHD20002000	1SS133 T-77	1SS133 T-77
P701	D703		00MHD20002000	00MHD20002000	1SS133 T-77	1SS133 T-77
P701	D704		00MHD20002000	00MHD20002000	1SS133 T-77	1SS133 T-77
P701	D705		00MHD20002000	00MHD20002000	1SS133 T-77	1SS133 T-77
P701	D706		00MHD20002000	00MHD20002000	1SS133 T-77	1SS133 T-77
P701	D707		00MHD20002000	00MHD20002000	1SS133 T-77	1SS133 T-77
P701	D708		00MHD20002000	00MHD20002000	1SS133 T-77	1SS133 T-77
P701	D709		00MHD20002000	00MHD20002000	1SS133 T-77	1SS133 T-77
P701	D710		00MHD20002000	00MHD20002000	1SS133 T-77	1SS133 T-77
P701	D711		00MHD20002000	00MHD20002000	1SS133 T-77	1SS133 T-77
P701	D712		00MHD20002000	00MHD20002000	1SS133 T-77	1SS133 T-77
P701	D713		00MHD20002000	00MHD20002000	1SS133 T-77	1SS133 T-77
P701	D714		00MHD20002000	00MHD20002000	1SS133 T-77	1SS133 T-77
P701	D715		00MHD20002000	00MHD20002000	1SS133 T-77	1SS133 T-77
P701	D716		00MHD20002000	00MHD20002000	1SS133 T-77	1SS133 T-77
P701	D718		00MHD20027010	00MHD20027010	HSS81TD-E 150V 150MA AXIAL TAPG.	HSS81TD-E 150V 150MA AXIAL TAPG.
P701	D719		00MHD20027010	00MHD20027010	HSS81TD-E 150V 150MA AXIAL TAPG.	HSS81TD-E 150V 150MA AXIAL TAPG.
P701	J701		00MYP06003850	00MYP06003850	B2B-EH	B2B-EH
P701	J705		00MYP06003830	00MYP06003830	B3B-EH-TS (LF)(SN) 3P RADIAL TAPING	B3B-EH-TS (LF)(SN) 3P RADIAL TAPING
P701	J706		00MYJ06006220	00MYJ06006220	B2B-PH-K-S (LF)(SN)	B2B-PH-K-S (LF)(SN)
P701	J707		00MYP07005670	00MYP07005670	IMSA-6065B-06Z065-PT1	IMSA-6065B-06Z065-PT1
P701	J708		00MYP07005670	00MYP07005670	IMSA-6065B-06Z065-PT1	IMSA-6065B-06Z065-PT1
P701	J709		00MYP06003830	00MYP06003830	B3B-EH-TS (LF)(SN) 3P RADIAL TAPING	B3B-EH-TS (LF)(SN) 3P RADIAL TAPING
P701	▲ KT71		00MHK185919C0	00MHK185919C0	! 2SA1859/C4883 O/O OR Y/Y PAIR	2SA1859/C4883 O/O OR Y/Y PAIR
P701	Q701		00MHT600121A0	00MHT600121A0	KTA1268 PNP TRANSISTOR RANK=GR	KTA1268 PNP TRANSISTOR RANK=GR
P701	Q702		00MKH27AJ1010	00MKH27AJ1010	HDAM-SA2D	HDAM-SA2D
P701	Q703		00MHT800931A0	00MHT800931A0	KTC3200 NPN TRANSISTOR RANK=GR	KTC3200 NPN TRANSISTOR RANK=GR
P701	Q704		00MHT800931A0	00MHT800931A0	KTC3200 NPN TRANSISTOR RANK=GR	KTC3200 NPN TRANSISTOR RANK=GR
P701	Q705		00MHT600121A0	00MHT600121A0	KTA1268 PNP TRANSISTOR RANK=GR	KTA1268 PNP TRANSISTOR RANK=GR
P701	Q706		00MHT600121A0	00MHT600121A0	KTA1268 PNP TRANSISTOR RANK=GR	KTA1268 PNP TRANSISTOR RANK=GR
P701	Q707		00MHT800931A0	00MHT800931A0	KTC3200 NPN TRANSISTOR RANK=GR	KTC3200 NPN TRANSISTOR RANK=GR
P701	Q708		00MHT600121A0	00MHT600121A0	KTA1268 PNP TRANSISTOR RANK=GR	KTA1268 PNP TRANSISTOR RANK=GR
P701	Q709		00MHT111452A0	00MHT111452A0	2SA1145 O OR Y	2SA1145 O OR Y TAPING TOSHIBA
P701	Q710		00MHT327052A0	00MHT327052A0	2SC2705 O OR Y	2SC2705 O OR Y TAPING TOSHIBA
P701	Q711		00MHT800931A0	00MHT800931A0	KTC3200 NPN TRANSISTOR RANK=GR	KTC3200 NPN TRANSISTOR RANK=GR
P701	Q712		00MHT800931A0	00MHT800931A0	KTC3200 NPN TRANSISTOR RANK=GR	KTC3200 NPN TRANSISTOR RANK=GR
P701	Q713		00MHT600121A0	00MHT600121A0	KTA1268 PNP TRANSISTOR RANK=GR	KTA1268 PNP TRANSISTOR RANK=GR
P701	Q714		00MHT600121A0	00MHT600121A0	KTA1268 PNP TRANSISTOR RANK=GR	KTA1268 PNP TRANSISTOR RANK=GR
P701	Q715		00MKH27AJ1010	00MKH27AJ1010	HDAM-SA2D	HDAM-SA2D
P701	Q716		00MHT800931A0	00MHT800931A0	KTC3200 NPN TRANSISTOR RANK=GR	KTC3200 NPN TRANSISTOR RANK=GR
P701	▲ Q717		00MHT334191Y0	00MHT334191Y0	! 2SC3419	TRANSISTOR C3419 Y 40V 0.8A PC=1.2W (5W)
P701	Q718		00MHT327052A0	00MHT327052A0	2SC2705 O OR Y	2SC2705 O OR Y TAPING TOSHIBA
P701	Q719		00MHT111452A0	00MHT111452A0	2SA1145 O OR Y	2SA1145 O OR Y TAPING TOSHIBA

NOTE : "nsp" PART IS LISTED FOR REFERENCE ONLY, D&M WILL NOT SUPPLY THESE PARTS.

PCB NAME	POS. NO.	VERS. COLOR	PART NO. (FOR EUR)	PART NO. (MJI)	PART NAME	DESCRIPTION
P701	▲ Q720		00MHT348832A0	00MHT348832A0	! TRANSISTOR 2SC4883 O OR Y	TRANSISTOR 2SC4883 O OR Y
P701	▲ Q721		00MHT118592A0	00MHT118592A0	! TRANSISTOR 2SA1859 O OR Y	TRANSISTOR 2SA1859 O OR Y
P701	▲ KT07		00MHK130319A0	00MHK130319A0	! 2SA1303/2SC3284 (O P OR Y)PAIR	2SA1303/2SC3284 (O P OR Y)PAIR
P701	▲ Q722		00MHT332843A0	00MHT332843A0	! 2SC3284 (O P OR Y) PC=125W	2SC3284 (O P OR Y) PC=125W
P701	▲ Q723		00MHT113033A0	00MHT113033A0	! 2SA1303 (O P OR Y) PC=125W	TRANSISTOR 2SA1303 (O P OR Y) PC=125W
P701	Q724		00MHT800931A0	00MHT800931A0	KTC3200 NPN TRANSISTOR RANK=GR	KTC3200 NPN TRANSISTOR RANK=GR
P701	Q725		00MHT600121A0	00MHT600121A0	KTA1268 PNP TRANSISTOR RANK=GR	KTA1268 PNP TRANSISTOR RANK=GR
P701	R702		00MGM11410030	00MGM11410030	100K OHM +-1% 1/4W	100K OHM +-1% 1/4W
P701	R703		00MGM11422620	00MGM11422620	22.6K OHM +- 1% 1/4W	22.6K OHM +- 1% 1/4W
P701	R704		00MGM11410000	00MGM11410000	100 OHM +-1% 1/4W	100 OHM +-1% 1/4W
P701	R708		00MGM11410000	00MGM11410000	100 OHM +-1% 1/4W	100 OHM +-1% 1/4W
P701	▲ R709		00MGG05471160	00MGG05471160	470 OHM +- 5% 1/6W	470 OHM +- 5% 1/6W
P701	▲ R710		00MGG05471160	00MGG05471160	470 OHM +- 5% 1/6W	470 OHM +- 5% 1/6W
P701	▲ R711		00MGG05151160	00MGG05151160	! 150 OHM +- 5% 1/6W	150 OHM +- 5% 1/6W
P701	R712		00MGM11410041	00MGM11410041	1M OHM +-1% 1/4W	1M OHM +-1% 1/4W
P701	R713		00MGM11410041	00MGM11410041	1M OHM +-1% 1/4W	1M OHM +-1% 1/4W
P701	▲ R714		00MGG05151160	00MGG05151160	! 150 OHM +- 5% 1/6W	150 OHM +- 5% 1/6W
P701	R715		00MGA05152010	00MGA05152010	1.5K OHM +- 5% 1W	1.5K OHM +- 5% 1W
P701	R725		00MRA02220760	00MRA02220760	VARIABLE RESISTOR 2.2KOHM VERT	VARIABLE RESISTOR 2.2KOHM VERT
P701	R729		00MRA01020760	00MRA01020760	VARIABLE RESISTOR 1K VERTICAL	VARIABLE RESISTOR 1K VERTICAL
P701	▲ R731		00MGG05100140	00MGG05100140	! 10 OHM +- 5% 1/4W	10 OHM +- 5% 1/4W
P701	▲ R732		00MGG05101160	00MGG05101160	! 100 OHM +- 5% 1/6W	100 OHM +- 5% 1/6W
P701	▲ R733		00MGG05101160	00MGG05101160	! 100 OHM +- 5% 1/6W	100 OHM +- 5% 1/6W
P701	▲ R734		00MGG05100140	00MGG05100140	! 10 OHM +- 5% 1/4W	10 OHM +- 5% 1/4W
P701	▲ R735		00MGG05102160	00MGG05102160	! 1K OHM +- 5% 1/6W	1K OHM +- 5% 1/6W
P701	▲ R736		00MGG05470160	00MGG05470160	! 47 OHM +- 5% 1/6W	47 OHM +- 5% 1/6W
P701	▲ R737		00MGG05470160	00MGG05470160	! 47 OHM +- 5% 1/6W	47 OHM +- 5% 1/6W
P701	▲ R738		00MGG05221140	00MGG05221140	! 220 OHM +- 5% 1/4W	220 OHM +- 5% 1/4W
P701	▲ R739		00MGG05100160	00MGG05100160	! 10 OHM +- 5% 1/6W	10 OHM +- 5% 1/6W
P701	▲ R740		00MGG05100160	00MGG05100160	! 10 OHM +- 5% 1/6W	10 OHM +- 5% 1/6W
P701	▲ R741		00MGO05001050	00MGO05001050	! 0.1 OHMS +-5% 5W PBR58	0.1 OHMS +-5% 5W PBR58
P701	▲ R742		00MGO05001050	00MGO05001050	! 0.1 OHMS +-5% 5W PBR58	0.1 OHMS +-5% 5W PBR58
P701	▲ R745		00MGG05102160	00MGG05102160	! 1K OHM +- 5% 1/6W	1K OHM +- 5% 1/6W
P701	▲ R746		00MGG05102160	00MGG05102160	! 1K OHM +- 5% 1/6W	1K OHM +- 5% 1/6W
P701	R747		00MGG05472160	00MGG05472160	4.7K OHM +- 5% 1/6W	4.7K OHM +- 5% 1/6W
					RCH POSISTOR PWB(00MWA27AJ207-)	
P751	▲ R771		00MHP00033240	00MHP00033240	! PTH9M04BC222TS2F333	VARISTOR PTH9M04BC222TS2F333 (MURATA)
P751	▲ R772	U1B	00MHP00033240	00MHP00033240	! PTH9M04BC222TS2F333	VARISTOR PTH9M04BC222TS2F333 (MURATA)
					RECT PWB(00MWA27AJ205-)	
P801	C821		00MOA10605020	00MOA10605020	10 UF M 50V RA-2	10 UF M 50V RA-2
P801	C824		00MOA10605020	00MOA10605020	10 UF M 50V RA-2	10 UF M 50V RA-2
P801	C834		00MOA10803520	00MOA10803520	1000 UF M 35V RA-2	1000 UF M 35V RA-2
P801	C836		00MOA10605020	00MOA10605020	10 UF M 50V RA-2	10 UF M 50V RA-2
P801	▲ D801		00MHE10005100	00MHE10005100	! SBD UNIT FCH20A15 TO-220	SBD UNIT FCH20A15 TO-220
P801	▲ D802		00MHE10006100	00MHE10006100	! SBD UNIT FRH20A15 TO-220	SBD UNIT FRH20A15 TO-220
P801	▲ D831		00MHD20002710	00MHD20002710	! 1D3 1A/200V	1D3 1A/200V
P801	▲ D832		00MHD20002710	00MHD20002710	! 1D3 1A/200V	1D3 1A/200V
P801	▲ D833		00MHD20002710	00MHD20002710	! 1D3 1A/200V	1D3 1A/200V
P801	▲ D834		00MHD20002710	00MHD20002710	! 1D3 1A/200V	1D3 1A/200V
P801	▲ D835		00MHD20002710	00MHD20002710	! 1D3 1A/200V	1D3 1A/200V
P801	▲ D836		00MHD20002710	00MHD20002710	! 1D3 1A/200V	1D3 1A/200V
P801	▲ G801		00MBF68400010	00MBF68400010	! 0.68UF/4.7OHM	! 0.68UF/4.7OHM
P801	▲ G831		00MBF68400010	00MBF68400010	! 0.68UF/4.7OHM	! 0.68UF/4.7OHM
P801	J801		00MYP04000760	00MYP04000760	CONNECTOR 2P B3P-VH	CONNECTOR 2P B3P-VH
P801	J804		00MYP06902270	00MYP06902270	05MQ-ST-L	05MQ-ST-L
P801	J832		00MYP06006840	00MYP06006840	B2P-VH 2P PLUG	B2P-VH 2P PLUG
P801	Q821		00D2730468907	00D2730468907	KTC3199 NPN TRANSISTOR RANK=Y	KTC3199-GR-AT/P
P801	Q822		00D2730468907	00D2730468907	KTC3199 NPN TRANSISTOR RANK=Y	KTC3199-GR-AT/P
P801	Q823		00D2730468907	00D2730468907	KTC3199 NPN TRANSISTOR RANK=Y	KTC3199-GR-AT/P
P801	Q824		00D2730468907	00D2730468907	KTC3199 NPN TRANSISTOR RANK=Y	KTC3199-GR-AT/P

NOTE : *nsp* PART IS LISTED FOR REFERENCE ONLY, D&M WILL NOT SUPPLY THESE PARTS.

PCB NAME	POS. NO.	VERS. COLOR	PART NO. (FOR EUR)	PART NO. (MJI)	PART NAME	DESCRIPTION
P801	Q835		00D2710311906	00D2710311906	KTA1267-GR-AT/P	KTA1267-GR-AT/P
P801	▲ R838		00MGG05010140	00MGG05010140	! 1 OHM 1/4W	1 OHM +-5% 1/4W MATSUSHITA:ERD25FYJ1R0T
					STANDBY PWB(00MWA27AJ208-)	
P851	C822		1340500220070	1340500220070	UFW1V472MHD1AA	UFW1V472MHD1AA
P851	C823		1340500220070	1340500220070	UFW1V472MHD1AA	UFW1V472MHD1AA
P851	C831		00MOA10603520	00MOA10603520	ROS-35V 100M (10UF 35V)	ROS-35V 100M - F3#PE - T2 (10UF 35V)
P851	C832		00MOA22703520	00MOA22703520	220UF 35V M RA-2	220UF 35V M RA-2
P851	C833		00MOA10605020	00MOA10605020	10 UF M 50V RA-2	10 UF M 50V RA-2
P851	C850		00MDD38104010	00MDD38104010	50V DC 0.1UF +80 -20%	50V DC 0.1UF +80 -20%
P851	C851		00MOF15103540	00MOF15103540	APSV 103J,0.01UF(TP) 100V PP	APSV 103J 0.01UF(TP) 100V PP
P851	▲ C852		133750061200S	133750061200S	# PHE840MA5100MA01R05	#PHE840MA5100MA01R05
P851	C853		00MOA10605020	00MOA10605020	10 UF M 50V RA-2	10 UF M 50V RA-2
P851	C854		00MOA10505020	00MOA10505020	1 UF M 50V RA-2	1 UF M 50V RA-2
P851	C855		00MOA22803520	00MOA22803520	2200UF 35V RA2	2200UF M 35V RA-2
P851	▲ C856		133750061200S	133750061200S	# PHE840MA5100MA01R05	#PHE840MA5100MA01R05
P851	C857		00MOA10605020	00MOA10605020	10 UF M 50V RA-2	10 UF M 50V RA-2
P851	C858		00MOA10605020	00MOA10605020	10 UF M 50V RA-2	10 UF M 50V RA-2
P851	C859		00MOA10605020	00MOA10605020	10 UF M 50V RA-2	10 UF M 50V RA-2
P851	▲ D821		00MHD20055100	00MHD20055100	! SHOTTKY 11EQS10 1A 100V	!SHOTTKY 11EQS10 1A 100V
P851	▲ D822		00MHD20055100	00MHD20055100	! SHOTTKY 11EQS10 1A 100V	!SHOTTKY 11EQS10 1A 100V
P851	▲ D823		00MHD20055100	00MHD20055100	! SHOTTKY 11EQS10 1A 100V	!SHOTTKY 11EQS10 1A 100V
P851	▲ D824		00MHD20055100	00MHD20055100	! SHOTTKY 11EQS10 1A 100V	!SHOTTKY 11EQS10 1A 100V
P851	▲ D851		00MHD20002710	00MHD20002710	! 1D3 1A/200V	1D3 1A/200V
P851	▲ D852		00MHD20002710	00MHD20002710	! 1D3 1A/200V	1D3 1A/200V
P851	▲ D853		00MHD20002710	00MHD20002710	! 1D3 1A/200V	1D3 1A/200V
P851	▲ D854		00MHD20002710	00MHD20002710	! 1D3 1A/200V	1D3 1A/200V
P851	▲ D855		00MHD20002710	00MHD20002710	! 1D3 1A/200V	1D3 1A/200V
P851	▲ D856		00MHD20002710	00MHD20002710	! 1D3 1A/200V	1D3 1A/200V
P851	D857		00MHD31801000	00MHD31801000	18V ZENER EQUIVALENT	18V ZENER EQUIVALENT
P851	▲ F851	FN	0520100190020	0520100190020	# T8A L 250V FUSE	0218008.MXP T8A L 250V
P851	▲ F851	K1G	0520100160030	0520100160030	# T4A L 250V FUSE	0218004.MXP
P851	▲ F851	N1B	0520100160030	0520100160030	# T4A L 250V FUSE	0218004.MXP
P851	▲ F851	U1B	0520100190020	0520100190020	# T8A L 250V FUSE	0218008.MXP T8A L 250V
P851	▲ G821		00MBF68400010	00MBF68400010	! 0.68UF/4.7OHM	! 0.68UF/4.7OHM
P851	J821		00MYP06006860	00MYP06006860	JST 3P-PLUG B3P-VH P=3.96M/M	JST 3P-PLUG B3P-VH P=3.96M/M
P851	J822		00MYP06010450	00MYP06010450	B5B-EH-TS (LF)(SN) 5P RADIAL TAPING	B5B-EH-TS (LF)(SN) 5P RADIAL TAPING
P851	J831		00MYP06010450	00MYP06010450	B5B-EH-TS (LF)(SN) 5P RADIAL TAPING	B5B-EH-TS (LF)(SN) 5P RADIAL TAPING
P851	J833		00MYJ06031580	00MYJ06031580	B05P-MQ-C	B05P-MQ-C
P851	J851		00MYP04000760	00MYP04000760	CONNECTOR 2P B3P-VH	CONNECTOR 2P B3P-VH
P851	J852		00MYP04000760	00MYP04000760	CONNECTOR 2P B3P-VH	CONNECTOR 2P B3P-VH
P851	J853		00MYP04000760	00MYP04000760	CONNECTOR 2P B3P-VH	CONNECTOR 2P B3P-VH
P851	J854		00MYJ06006300	00MYJ06006300	B10B-PH-K-S (LF)(SN)	B10B-PH-K-S (LF)(SN)
P851	▲ L851	FN	101710066002M	101710066002M	# STANDBY TRANSFORMER FOR 100V	# STANDBY TRANSFORMER FOR 100V
P851	▲ L851	K1G	101710067005M	101710067005M	# STANDBY TRANSFORMER 230V	# STANDBY TRANS FOR 230V
P851	▲ L851	N1B	101710067005M	101710067005M	# STANDBY TRANSFORMER 230V	# STANDBY TRANS FOR 230V
P851	▲ L851	U1B	101710068008M	101710068008M	# STANDBY TRANSFORMER FOR 120V	# STANDBY TRANS FOR 120V
P851	▲ L852		682010006001S	682010006001S	! FTR-H2AK009T	FTR-H2AK009T
P851	L853		00MFC90050130	00MFC90050130	BL02RN2-R62T2 FERRITE BEAD	BL02RN2-R62T2 FERRITE BEAD
P851	L854		00MFC90050130	00MFC90050130	BL02RN2-R62T2 FERRITE BEAD	BL02RN2-R62T2 FERRITE BEAD
P851	L855		00MFC90050130	00MFC90050130	BL02RN2-R62T2 FERRITE BEAD	BL02RN2-R62T2 FERRITE BEAD
P851	L856		00MFC90050130	00MFC90050130	BL02RN2-R62T2 FERRITE BEAD	BL02RN2-R62T2 FERRITE BEAD
P851	L857		00MFC90050130	00MFC90050130	BL02RN2-R62T2 FERRITE BEAD	BL02RN2-R62T2 FERRITE BEAD
P851	L858		00MFC90050130	00MFC90050130	BL02RN2-R62T2 FERRITE BEAD	BL02RN2-R62T2 FERRITE BEAD
P851	L859		00MFC90050130	00MFC90050130	BL02RN2-R62T2 FERRITE BEAD	BL02RN2-R62T2 FERRITE BEAD
P851	L860		00MFC90050130	00MFC90050130	BL02RN2-R62T2 FERRITE BEAD	BL02RN2-R62T2 FERRITE BEAD
P851	L861		00MFC90050130	00MFC90050130	BL02RN2-R62T2 FERRITE BEAD	BL02RN2-R62T2 FERRITE BEAD
P851	L862		00MFC90050130	00MFC90050130	BL02RN2-R62T2 FERRITE BEAD	BL02RN2-R62T2 FERRITE BEAD
P851	L863		00MFC90050130	00MFC90050130	BL02RN2-R62T2 FERRITE BEAD	BL02RN2-R62T2 FERRITE BEAD
P851	Q831		00D2710311906	00D2710311906	KTA1267-GR-AT/P	KTA1267-GR-AT/P
P851	Q832		00MHT41415100	00MHT41415100	TRANSISTOR 2SD1415	TRANSISTOR 2SD1415
P851	▲ Q833		00MHC3851509F	00MHC3851509F	! NJM78M15FA(0.5A 15V)	NJM78M15FA(0.5A 15V) FULLPACK
P851	Q834		00D2690206908	00D2690206908	KRC102M-AT/P (10K-10K)	KRC102M-AT/P (10K-10K)
P851	Q851		00D2710311906	00D2710311906	KTA1267-GR-AT/P	KTA1267-GR-AT/P

NOTE : "nsp" PART IS LISTED FOR REFERENCE ONLY, D&M WILL NOT SUPPLY THESE PARTS.

PCB NAME	POS. NO.	VERS. COLOR	PART NO. (FOR EUR)	PART NO. (MJ)	PART NAME	DESCRIPTION
P851	Q852		00D2690206908	00D2690206908	KRC102M-AT/P (10K-10K)	KRC102M-AT/P (10K-10K)
P851	▲ Q853		00MHC3850509F	00MHC3850509F	! NJM78M05FA	NJM78M05FA
P851	Q854		00MHT800931A0	00MHT800931A0	KTC3200 NPN TRANSISTOR RANK=GR	KTC3200 NPN TRANSISTOR RANK=GR
P851	Q855		00D2690206908	00D2690206908	KRC102M-AT/P (10K-10K)	KRC102M-AT/P (10K-10K)
P851	▲ R825		00MGG05010120	00MGG05010120	! ERD50FJ1R0P or SPRX1CM12.5A J 1R0	ERD50FJ1R0P or SPRX1CM12.5A J 1R0
P851	▲ R826		00MGG05010120	00MGG05010120	! ERD50FJ1R0P or SPRX1CM12.5A J 1R0	ERD50FJ1R0P or SPRX1CM12.5A J 1R0
P851	▲ R833		00MGG05100160	00MGG05100160	! 10 OHM +- 5% 1/6W	10 OHM +- 5% 1/6W
P851	▲ R851		00MGG05220160	00MGG05220160	! 22 OHM +- 5% 1/6W	22 OHM +- 5% 1/6W
					POWER SW PWB(00MWA27AJ210-)	
P891	▲ C891		00MDK17471520	00MDK17471520	! DE0910 B 471K -KX 470PF 250V	DE0910 B 471K -KX 470PF 250V
P891	J891		00MYP06013300	00MYP06013300	2P PLUG B2P3S-VH	2P PLUG B2P3S-VH
P891	▲ S891		665010008002D	665010008002D	! POWER SWITCH (TV-5)	POWER SWITCH (TV-5)
					SPK OUT PWB(00MWA27AJ204-)	
P951	C901	K1G	00MOF55103580	00MOF55103580	0.01UF 100V +- 5% FNS	0.01UF 100V +- 5% FNS
P951	C901	N1B	00MOF55103580	00MOF55103580	0.01UF 100V +- 5% FNS	0.01UF 100V +- 5% FNS
P951	C902	K1G	00MOF55103580	00MOF55103580	0.01UF 100V +- 5% FNS	0.01UF 100V +- 5% FNS
P951	C902	N1B	00MOF55103580	00MOF55103580	0.01UF 100V +- 5% FNS	0.01UF 100V +- 5% FNS
P951	C903		00MOF55393580	00MOF55393580	0.039UF 100V +- 5% FAS	0.039UF 100V +- 5% FAS
P951	C904		00MOF55393580	00MOF55393580	0.039UF 100V +- 5% FAS	0.039UF 100V +- 5% FAS
P951	C951		00MOA47602520	00MOA47602520	47 UF M 25V RA-2	47 UF M 25V RA-2
P951	C955		00MOA10603520	00MOA10603520	ROS-35V 100M (10UF 35V)	ROS-35V 100M - F3#PE - T2 (10UF 35V)
P951	D901		00MHD20002000	00MHD20002000	1SS133 T-77	1SS133 T-77
P951	D902		00MHD20002000	00MHD20002000	1SS133 T-77	1SS133 T-77
P951	D903		00MHD20002000	00MHD20002000	1SS133 T-77	1SS133 T-77
P951	D904		00MHD20002000	00MHD20002000	1SS133 T-77	1SS133 T-77
P951	D951		00MHD20002000	00MHD20002000	1SS133 T-77	1SS133 T-77
P951	D952		00MHD20002000	00MHD20002000	1SS133 T-77	1SS133 T-77
P951	J905		00MYP06003830	00MYP06003830	B3B-EH-TS (LF)(SN) 3P RADIAL TAPING	B3B-EH-TS (LF)(SN) 3P RADIAL TAPING
P951	J906		00MYP06003830	00MYP06003830	B3B-EH-TS (LF)(SN) 3P RADIAL TAPING	B3B-EH-TS (LF)(SN) 3P RADIAL TAPING
P951	J907		00MYP06010450	00MYP06010450	B5B-EH-TS (LF)(SN) 5P RADIAL TAPING	B5B-EH-TS (LF)(SN) 5P RADIAL TAPING
P951	J908		00MYP06003850	00MYP06003850	B2B-EH	B2B-EH
P951	▲ L901		00D2140213001	00D2140213001	! RELAY(FTR-F4)	RELAY(FTR-F4)
P951	▲ L902		00D2140208003	00D2140208003	! RELAY(NA24W-K)	RELAY(NA24W-K)
P951	Q951		00D2710311906	00D2710311906	KTA1267-GR-AT/P	KTA1267-GR-AT/P
P951	Q952		00D2690206908	00D2690206908	KRC102M-AT/P (10K-10K)	KRC102M-AT/P (10K-10K)
P951	Q953		00D2690206908	00D2690206908	KRC102M-AT/P (10K-10K)	KRC102M-AT/P (10K-10K)
P951	Q954		00D2730468907	00D2730468907	KTC3199-GR-AT/P	KTC3199-GR-AT/P
P951	Q955		00D2730468907	00D2730468907	KTC3199-GR-AT/P	KTC3199-GR-AT/P
P951	Q956		00D2730468907	00D2730468907	KTC3199-GR-AT/P	KTC3199-GR-AT/P
P951	Q957		00D2690206908	00D2690206908	KRC102M-AT/P (10K-10K)	KRC102M-AT/P (10K-10K)
P951	Q958		00D2710311906	00D2710311906	KTA1267-GR-AT/P	KTA1267-GR-AT/P
P951	Q959		00D2730468907	00D2730468907	KTC3199-GR-AT/P	KTC3199-GR-AT/P
P951	Q960		00D2710311906	00D2710311906	KTA1267-GR-AT/P	KTA1267-GR-AT/P
P951	Q961		00D2690206908	00D2690206908	KRC102M-AT/P (10K-10K)	KRC102M-AT/P (10K-10K)
P951	Q962		00D2690206908	00D2690206908	KRC102M-AT/P (10K-10K)	KRC102M-AT/P (10K-10K)
P951	Q963		00D2690206908	00D2690206908	KRC102M-AT/P (10K-10K)	KRC102M-AT/P (10K-10K)
P951	Q964		00D2690206908	00D2690206908	KRC102M-AT/P (10K-10K)	KRC102M-AT/P (10K-10K)
P951	Q965		00D2690204900	00D2690204900	KRA102M-AT/P (10K-10K)	KRA102M-AT/P (10K-10K)
P951	▲ R901		00MKNK05100020	00MKNK05100020	! 10 OHM +- 5% 2W	10 OHM +- 5% 2W
P951	▲ R902		00MKNK05100020	00MKNK05100020	! 10 OHM +- 5% 2W	10 OHM +- 5% 2W
P951	▲ R905		00MKNK05331020	00MKNK05331020	! 330 OHM +- 5% 2W	330 OHM +- 5% 2W
P951	▲ R906		00MKNK05331020	00MKNK05331020	! 330 OHM +- 5% 2W	330 OHM +- 5% 2W
P951	▲ R907		00MGG05220160	00MGG05220160	! 22 OHM +- 5% 1/6W	22 OHM +- 5% 1/6W
P951	▲ R908		00MGG05220160	00MGG05220160	! 22 OHM +- 5% 1/6W	22 OHM +- 5% 1/6W
					HP OUT PWB(00MWA27AJ211-)	
P991	C991	K1G	00MOF15103540	00MOF15103540	APSV 103J 0.01UF(TP) 100V PP	APSV 103J 0.01UF(TP) 100V PP
P991	C991	N1B	00MOF15103540	00MOF15103540	APSV 103J 0.01UF(TP) 100V PP	APSV 103J 0.01UF(TP) 100V PP
P991	C992	K1G	00MOF15103540	00MOF15103540	APSV 103J 0.01UF(TP) 100V PP	APSV 103J 0.01UF(TP) 100V PP
P991	C992	N1B	00MOF15103540	00MOF15103540	APSV 103J 0.01UF(TP) 100V PP	APSV 103J 0.01UF(TP) 100V PP
P991	J991	FN	00MYJ01005190	00MYJ01005190	YKB21-5834N (GRY/GLD) HEADPHONE JACK	YKB21-5834N (GRY/GLD) HEADPHONE JACK

NOTE : "nsp" PART IS LISTED FOR REFERENCE ONLY, D&M WILL NOT SUPPLY THESE PARTS.

PCB NAME	POS. NO.	VERS. COLOR	PART NO. (FOR EUR)	PART NO. (MJI)	PART NAME	DESCRIPTION
P991	J991	K1G	00MYJ01005190	00MYJ01005190	YKB21-5834N (GRY/GLD) HEADPHONE JACK	YKB21-5834N (GRY/GLD) HEADPHONE JACK
P991	J991	N1B	6430100020040	6430100020040	YKB21-5805 HP JACK	YKB21-5805 HP JACK
P991	J991	U1B	6430100020040	6430100020040	YKB21-5805 HP JACK	YKB21-5805 HP JACK
P991	J992		00MYP06003850	00MYP06003850	B2B-EH	B2B-EH
P991	R991		00MGG05470160	00MGG05470160	00MGG0547016X	47 OHM +- 5% 1/6W
P991	R992		00MGG05470160	00MGG05470160	00MGG0547016X	47 OHM +- 5% 1/6W
					FCBS PWB(00MWG27AJ306-)	
PB01	CB01		nsp	00MDK98104200	GRM39F104Z16 0.1UF MURATA	GRM39F104Z16 0.1UF MURATA
PB01	CB02		nsp	00MDK98104200	GRM39F104Z16 0.1UF MURATA	GRM39F104Z16 0.1UF MURATA
PB01	CB03		00MEG10601650	00MEG10601650	10UF/ 16V	10UF/ 16V
PB01	CB12		nsp	00MDK96102300	1000 PF +- 10 % B 50V GR36	1000 PF +- 10 % B 50V GR36
PB01	CB13		nsp	00MDK96102300	1000 PF +- 10 % B 50V GR36	1000 PF +- 10 % B 50V GR36
PB01	CB14		nsp	00MDK96102300	1000 PF +- 10 % B 50V GR36	1000 PF +- 10 % B 50V GR36
PB01	CB15		nsp	00MDK98104200	GRM39F104Z16 0.1UF MURATA	GRM39F104Z16 0.1UF MURATA
PB01	CB16		nsp	00MDK98104200	GRM39F104Z16 0.1UF MURATA	GRM39F104Z16 0.1UF MURATA
PB01	DB01		00MHZ21005000	00MHZ21005000	1SS301 DAN202U UMT TYPE	1SS301 DAN202U UMT TYPE
PB01	JB02		00MYJ06006270	00MYJ06006270	B7B-PH-K-S (LF)(SN)	B7B-PH-K-S (LF)(SN)
PB01	JB11		00MYJ01004670	00MYJ01004670	LG6501-0600 3.5 MINI JACK	LG6501-0600 3.5 MINI JACK
PB01	JB12		00MYJ01004670	00MYJ01004670	LG6501-0600 3.5 MINI JACK	LG6501-0600 3.5 MINI JACK
PB01	JB13		00MYJ07060400	00MYJ07060400	05FMN-SSTK-A FFC CONNECTOR	05FMN-SSTK-A FFC CONNECTOR
PB01	L404		00D2140208003	00D2140208003	RELAY(NA24W-K)	RELAY(NA24W-K)
PB01	LB03		00MFC90020210	00MFC90020210	MLB-1608-1000A-N2	MLB-1608-1000A-N2
PB01	QB01		00MBA21303000	00MBA21303000	DTC124EU RN1303 UMT TYPE	DTC124EU RN1303 UMT TYPE
PB01	QB02		00MBA10013050	00MBA10013050	RN2303(PNPX1(22K+22K))	RN2303(PNPX1(22K+22K))
PB01	QB05		00MBA21303000	00MBA21303000	DTC124EU RN1303 UMT TYPE	DTC124EU RN1303 UMT TYPE
PB01	▲ QB21		00MHW10006320	00MHW10006320		IPC-817 PHOTO CUPLER 1PAIR
PB01	RB02		00MGG05220160	00MGG05220160	22 OHM +- 5% 1/6W	22 OHM +- 5% 1/6W
PB01	RB03		nsp	00MNN05473610	47K OHM +- 5% 1/16W	47K OHM +- 5% 1/16W
PB01	RB04		nsp	00MNN05101610	100 OHM +- 5% 1/16W	100 OHM +- 5% 1/16W
PB01	RB05		nsp	00MNN05103610	10K OHM +- 5% 1/16W	10K OHM +- 5% 1/16W
PB01	RB06		nsp	00MNN05102610	1K OHM +- 5% 1/16W	1K OHM +- 5% 1/16W
PB01	RB08		nsp	00MNN05472610	4.7K OHM +- 5% 1/16W	4.7K OHM +- 5% 1/16W
PB01	RB11		00MGG05220160	00MGG05220160	22 OHM +- 5% 1/6W	22 OHM +- 5% 1/6W
PB01	RB12		nsp	00MNN05561610	560 OHM +- 5% 1/16W	560 OHM +- 5% 1/16W
PB01	SB01		00MSS02021620	00MSS02021620	SSSU121700	SSSU121700
					FRONT PWB(00MWG27AJ301-)	
PD01	CU01		nsp	00MDK96103300	0.01UF +-10% 50V C1608JB1H103K	0.01UF +-10% 50V C1608JB1H103K
PD01	CU02		nsp	00MDK96103300	0.01UF +-10% 50V C1608JB1H103K	0.01UF +-10% 50V C1608JB1H103K
PD01	CU03		nsp	00MDK96103300	0.01UF +-10% 50V C1608JB1H103K	0.01UF +-10% 50V C1608JB1H103K
PD01	CU04		nsp	00MDK96103300	0.01UF +-10% 50V C1608JB1H103K	0.01UF +-10% 50V C1608JB1H103K
PD01	CU05		nsp	00MDK98104200	GRM39F104Z16 0.1UF MURATA	GRM39F104Z16 0.1UF MURATA
PD01	CU06		nsp	00MDK98104200	GRM39F104Z16 0.1UF MURATA	GRM39F104Z16 0.1UF MURATA
PD01	CU07		nsp	00MDK98104200	GRM39F104Z16 0.1UF MURATA	GRM39F104Z16 0.1UF MURATA
PD01	CU08		nsp	00MDK98104200	GRM39F104Z16 0.1UF MURATA	GRM39F104Z16 0.1UF MURATA
PD01	CU09		nsp	00MDK98104200	GRM39F104Z16 0.1UF MURATA	GRM39F104Z16 0.1UF MURATA
PD01	CU10		nsp	00MEJ22700610	220UF/6.3V	220UF/6.3V
PD01	CU11		nsp	00MDK96103300	0.01UF +-10% 50V C1608JB1H103K	0.01UF +-10% 50V C1608JB1H103K
PD01	CU12		nsp	00MDK98104200	GRM39F104Z16 0.1UF MURATA	GRM39F104Z16 0.1UF MURATA
PD01	CU13		nsp	00MDK96102300	1000 PF +- 10 % B 50V GR36	1000 PF +- 10 % B 50V GR36
PD01	CU14		nsp	00MDK98104200	GRM39F104Z16 0.1UF MURATA	GRM39F104Z16 0.1UF MURATA
PD01	CU15		nsp	00MDK96103300	0.01UF +-10% 50V C1608JB1H103K	0.01UF +-10% 50V C1608JB1H103K
PD01	CU16		nsp	00MDK96102300	1000 PF +- 10 % B 50V GR36	1000 PF +- 10 % B 50V GR36
PD01	CU17		nsp	00MDK96102300	1000 PF +- 10 % B 50V GR36	1000 PF +- 10 % B 50V GR36
PD01	CU18		nsp	00MDK96103300	0.01UF +-10% 50V C1608JB1H103K	0.01UF +-10% 50V C1608JB1H103K
PD01	CU20		nsp	00MEJ22700610	220UF/6.3V	220UF/6.3V
PD01	CU21		00MDK98104200	00MDK98104200	GRM39F104Z16 0.1UF MURATA	GRM39F104Z16 0.1UF MURATA
PD01	CU28		00MDK96103300	00MDK96103300	0.01UF +-10% 50V C1608JB1H103K	0.01UF +-10% 50V C1608JB1H103K
PD01	CU29		00MDK96103300	00MDK96103300	0.01UF +-10% 50V C1608JB1H103K	0.01UF +-10% 50V C1608JB1H103K
PD01	CU30		00MDK96103300	00MDK96103300	0.01UF +-10% 50V C1608JB1H103K	0.01UF +-10% 50V C1608JB1H103K
PD01	CU31		00MDK96103300	00MDK96103300	0.01UF +-10% 50V C1608JB1H103K	0.01UF +-10% 50V C1608JB1H103K
PD01	CU40		00MDK96332300	00MDK96332300	3300PF (GR39)	3300PF (GR39)
PD01	CU61		00MDK96103300	00MDK96103300	0.01UF +-10% 50V C1608JB1H103K	0.01UF +-10% 50V C1608JB1H103K

NOTE : "nsp" PART IS LISTED FOR REFERENCE ONLY, D&M WILL NOT SUPPLY THESE PARTS.

PCB NAME	POS. NO.	VERS. COLOR	PART NO. (FOR EUR)	PART NO. (MJ)	PART NAME	DESCRIPTION
PD01	CU62		00MEG10601650	00MEG10601650	10UF/ 16V	10UF/ 16V
PD01	CU63		00MEG10601650	00MEG10601650	10UF/ 16V	10UF/ 16V
PD01	CU64		00MEG10601650	00MEG10601650	10UF/ 16V	10UF/ 16V
PD01	CU65		nsp	00MDK96103300	0.01UF +-10% 50V C1608JB1H103K	0.01UF +-10% 50V C1608JB1H103K
PD01	CU66		nsp	00MDK96103300	0.01UF +-10% 50V C1608JB1H103K	0.01UF +-10% 50V C1608JB1H103K
PD01	CU67		nsp	00MDK96103300	0.01UF +-10% 50V C1608JB1H103K	0.01UF +-10% 50V C1608JB1H103K
PD01	CU71		nsp	00MDK96103300	0.01UF +-10% 50V C1608JB1H103K	0.01UF +-10% 50V C1608JB1H103K
PD01	CU72		00MEG10601650	00MEG10601650	10UF/ 16V	10UF/ 16V
PD01	CU73		00MEG10601650	00MEG10601650	10UF/ 16V	10UF/ 16V
PD01	CU74		00MEG10601650	00MEG10601650	10UF/ 16V	10UF/ 16V
PD01	CU75		nsp	00MDK96103300	0.01UF +-10% 50V C1608JB1H103K	0.01UF +-10% 50V C1608JB1H103K
PD01	CU76		nsp	00MDK96103300	0.01UF +-10% 50V C1608JB1H103K	0.01UF +-10% 50V C1608JB1H103K
PD01	CU77		nsp	00MDK96103300	0.01UF +-10% 50V C1608JB1H103K	0.01UF +-10% 50V C1608JB1H103K
PD01	CU83		nsp	00MDK96103300	0.01UF +-10% 50V C1608JB1H103K	0.01UF +-10% 50V C1608JB1H103K
PD01	DD02		00MHZ2001805Y	00MHZ20018050	1SS302 (TE85L F) (TOSHIBA)	1SS302 (TE85L F) (TOSHIBA)
PD01	DU61		263710015209S	263710015209S	SELT2E10C-S BALK F/G RANK	SELT2E10C-S BALK F/G RANK
PD01	DU62		00MHI10048080	00MHI10048080	SEL6E10C(F-RANK)BLUE LED	SEL6E10C(F-RANK)BLUE LED
PD01	DU63		00MHI10048080	00MHI10048080	SEL6E10C(F-RANK)BLUE LED	SEL6E10C(F-RANK)BLUE LED
PD01	DU71		263710015209S	263710015209S	SELT2E10C-S BALK F/G RANK	SELT2E10C-S BALK F/G RANK
PD01	DU72		00MHI10048080	00MHI10048080	SEL6E10C(F-RANK)BLUE LED	SEL6E10C(F-RANK)BLUE LED
PD01	DU73		00MHI10048080	00MHI10048080	SEL6E10C(F-RANK)BLUE LED	SEL6E10C(F-RANK)BLUE LED
PD01	JB01		00MYJ06006500	00MYJ06006500	S10B-PH-K-S (LF)(SN)	S10B-PH-K-S (LF)(SN)
PD01	JD03		00MYJ06006420	00MYJ06006420	S2B-PH-K-S (LF)(SN)	S2B-PH-K-S (LF)(SN)
PD01	JD04		00MYJ07061070	00MYJ07061070	14FMN-BTK-A	14FMN-BTK-A
PD01	JU01		00MYJ06006530	00MYJ06006530	S13B-PH-K-S (LF)(SN)	S13B-PH-K-S (LF)(SN)
PD01	JU02		00MYJ06006470	00MYJ06006470	S7B-PH-K-S (LF)(SN)	S7B-PH-K-S (LF)(SN)
PD01	JU62		00MYP06003930	00MYP06003930	S3B-EH	S3B-EH
PD01	JU82		00MYP06003940	00MYP06003940	S4B-EH	S4B-EH
PD01	LU01		00MFC90020210	00MFC90020210	MLB-1608-1000A-N2	MLB-1608-1000A-N2
PD01	LU02		00MFC90020210	00MFC90020210	MLB-1608-1000A-N2	MLB-1608-1000A-N2
PD01	LU03		00MFC90020210	00MFC90020210	MLB-1608-1000A-N2	MLB-1608-1000A-N2
PD01	LU04		00MFC90020210	00MFC90020210	MLB-1608-1000A-N2	MLB-1608-1000A-N2
PD01	LU05		00MFC90020210	00MFC90020210	MLB-1608-1000A-N2	MLB-1608-1000A-N2
PD01	LU06		00MFC90020210	00MFC90020210	MLB-1608-1000A-N2	MLB-1608-1000A-N2
PD01	LU07		00MFC90020210	00MFC90020210	MLB-1608-1000A-N2	MLB-1608-1000A-N2
PD01	LU08		00MFC90020210	00MFC90020210	MLB-1608-1000A-N2	MLB-1608-1000A-N2
PD01	LU09		00MFC90020210	00MFC90020210	MLB-1608-1000A-N2	MLB-1608-1000A-N2
PD01	LU10		00MFC90020210	00MFC90020210	MLB-1608-1000A-N2	MLB-1608-1000A-N2
PD01	LU11		00MFC90020210	00MFC90020210	MLB-1608-1000A-N2	MLB-1608-1000A-N2
PD01	LU12		00MFC90020210	00MFC90020210	MLB-1608-1000A-N2	MLB-1608-1000A-N2
PD01	LU13		00MFC90020210	00MFC90020210	MLB-1608-1000A-N2	MLB-1608-1000A-N2
PD01	LU15		00MFC90020210	00MFC90020210	MLB-1608-1000A-N2	MLB-1608-1000A-N2
PD01	LU17		00MFC90020210	00MFC90020210	MLB-1608-1000A-N2	MLB-1608-1000A-N2
PD01	LU19		00MFC90020210	00MFC90020210	MLB-1608-1000A-N2	MLB-1608-1000A-N2
PD01	LU20		00MFC90020210	00MFC90020210	MLB-1608-1000A-N2	MLB-1608-1000A-N2
PD01	LU21		00MFC90020210	00MFC90020210	MLB-1608-1000A-N2	MLB-1608-1000A-N2
PD01	LU22		00MFC90020210	00MFC90020210	MLB-1608-1000A-N2	MLB-1608-1000A-N2
PD01	LU23		00MFC90020210	00MFC90020210	MLB-1608-1000A-N2	MLB-1608-1000A-N2
PD01	QD01		00MHT600121A0	00MHT600121A0	KTA1268 PNP TRANSISTOR RANK=GR	KTA1268 PNP TRANSISTOR RANK=GR
PD01	QD30		00MBA21303000	00MBA21303000	DTC124EU RN1303 UMT TYPE	DTC124EU RN1303 UMT TYPE
PD01	QD31		00MBA10013050	00MBA10013050	RN2303(PNPX1(22K+22K))	RN2303(PNPX1(22K+22K))
PD01	QU01		00MHC60037010	00MHC60037010	HD64F3687H FLASH	HD64F3687H FLASH
PD01	QU02		00MHC10433990	00MHC10433990	AT24C08AN-10SI-2.7	AT24C08AN-10SI-2.7
PD01	QU03		00MHC809449R0	00MHC809449R0	74HC4094BT	74HC4094BT
PD01	QU04		00MHC10229210	00MHC10229210	BD4727G 2.7V RESET IC	BD4727G 2.7V RESET IC
PD01	QU07		00MHX100012A0	00MHX100012A0	2SA1586 (Y GR) TE85L / 2SA1576A (Q R)	2SA1586 (Y GR) TE85L / 2SA1576A (Q R)
PD01	QU08		00MHX300012A0	00MHX300012A0	2SC4081 (Q R) 2SC4116 (Y GR)	2SC4081 (Q R) 2SC4116 (Y GR)
PD01	QU09		00MHX300012A0	00MHX300012A0	2SC4081 (Q R) 2SC4116 (Y GR)	2SC4081 (Q R) 2SC4116 (Y GR)
PD01	QU12		00MBA10013050	00MBA10013050	RN2303(PNPX1(22K+22K))	RN2303(PNPX1(22K+22K))
PD01	QU14		00MBA21303000	00MBA21303000	DTC124EU RN1303 UMT TYPE	DTC124EU RN1303 UMT TYPE
PD01	QU15		00MBA21303000	00MBA21303000	DTC124EU RN1303 UMT TYPE	DTC124EU RN1303 UMT TYPE
PD01	QU16		00MBA21303000	00MBA21303000	DTC124EU RN1303 UMT TYPE	DTC124EU RN1303 UMT TYPE
PD01	QU19		00MBA21303000	00MBA21303000	DTC124EU RN1303 UMT TYPE	DTC124EU RN1303 UMT TYPE
PD01	QU20		00MBA21303000	00MBA21303000	DTC124EU RN1303 UMT TYPE	DTC124EU RN1303 UMT TYPE
PD01	QU21		00MBA21303000	00MBA21303000	DTC124EU RN1303 UMT TYPE	DTC124EU RN1303 UMT TYPE

NOTE : "nsp" PART IS LISTED FOR REFERENCE ONLY, D&M WILL NOT SUPPLY THESE PARTS.

PCB NAME	POS. NO.	VERS. COLOR	PART NO. (FOR EUR)	PART NO. (MJI)	PART NAME	DESCRIPTION
PD01	QU22		00MBA21303000	00MBA21303000	DTC124EU RN1303 UMT TYPE	DTC124EU RN1303 UMT TYPE
PD01	QU61		00MBA21303000	00MBA21303000	DTC124EU RN1303 UMT TYPE	DTC124EU RN1303 UMT TYPE
PD01	QU62		00MBA21303000	00MBA21303000	DTC124EU RN1303 UMT TYPE	DTC124EU RN1303 UMT TYPE
PD01	QU63		00MBA21303000	00MBA21303000	DTC124EU RN1303 UMT TYPE	DTC124EU RN1303 UMT TYPE
PD01	QU71		00MBA21303000	00MBA21303000	DTC124EU RN1303 UMT TYPE	DTC124EU RN1303 UMT TYPE
PD01	QU72		00MBA21303000	00MBA21303000	DTC124EU RN1303 UMT TYPE	DTC124EU RN1303 UMT TYPE
PD01	QU73		00MBA21303000	00MBA21303000	DTC124EU RN1303 UMT TYPE	DTC124EU RN1303 UMT TYPE
PD01	RD02		nsp	00MNN05330610	33 OHM +- 5% 1/16W	33 OHM +- 5% 1/16W
PD01	RD04		nsp	00MNN05223610	22K OHM +- 5% 1/16W	22K OHM +- 5% 1/16W
PD01	RU01		nsp	00MNN05104610	100K OHM +- 5% 1/16W	100K OHM +- 5% 1/16W
PD01	RU02		nsp	00MNN05103610	10K OHM +- 5% 1/16W	10K OHM +- 5% 1/16W
PD01	RU03		nsp	00MNN05103610	10K OHM +- 5% 1/16W	10K OHM +- 5% 1/16W
PD01	RU05		nsp	00MNN05473610	47K OHM +- 5% 1/16W	47K OHM +- 5% 1/16W
PD01	RU06		nsp	00MNN05473610	47K OHM +- 5% 1/16W	47K OHM +- 5% 1/16W
PD01	RU12		nsp	00MNN05103610	10K OHM +- 5% 1/16W	10K OHM +- 5% 1/16W
PD01	RU13		nsp	00MNN05473610	47K OHM +- 5% 1/16W	47K OHM +- 5% 1/16W
PD01	RU14		nsp	00MNN05473610	47K OHM +- 5% 1/16W	47K OHM +- 5% 1/16W
PD01	RU15		nsp	00MNN05472610	4.7K OHM +- 5% 1/16W	4.7K OHM +- 5% 1/16W
PD01	RU16		nsp	00MNN05472610	4.7K OHM +- 5% 1/16W	4.7K OHM +- 5% 1/16W
PD01	RU17		nsp	00MNN05223610	22K OHM +- 5% 1/16W	22K OHM +- 5% 1/16W
PD01	RU18		nsp	00MNN05104610	100K OHM +- 5% 1/16W	100K OHM +- 5% 1/16W
PD01	RU19		nsp	00MNN05472610	4.7K OHM +- 5% 1/16W	4.7K OHM +- 5% 1/16W
PD01	RU20		nsp	00MNN05153610	15K OHM +- 5% 1/16W	15K OHM +- 5% 1/16W
PD01	RU21		nsp	00MNN05473610	47K OHM +- 5% 1/16W	47K OHM +- 5% 1/16W
PD01	RU22		nsp	00MNN05473610	47K OHM +- 5% 1/16W	47K OHM +- 5% 1/16W
PD01	RU23		nsp	00MNN05473610	47K OHM +- 5% 1/16W	47K OHM +- 5% 1/16W
PD01	RU24		nsp	00MNN05473610	47K OHM +- 5% 1/16W	47K OHM +- 5% 1/16W
PD01	RU25		nsp	00MNN05473610	47K OHM +- 5% 1/16W	47K OHM +- 5% 1/16W
PD01	RU26		nsp	00MNN05473610	47K OHM +- 5% 1/16W	47K OHM +- 5% 1/16W
PD01	RU27		nsp	00MNN05473610	47K OHM +- 5% 1/16W	47K OHM +- 5% 1/16W
PD01	RU28		nsp	00MNN05473610	47K OHM +- 5% 1/16W	47K OHM +- 5% 1/16W
PD01	RU29		nsp	00MNN05101610	100 OHM +- 5% 1/16W	100 OHM +- 5% 1/16W
PD01	RU30		nsp	00MNN05183610	18K OHM +- 5% 1/16W	18K OHM +- 5% 1/16W
PD01	RU31		nsp	00MNN05473610	47K OHM +- 5% 1/16W	47K OHM +- 5% 1/16W
PD01	RU32		nsp	00MNN05473610	47K OHM +- 5% 1/16W	47K OHM +- 5% 1/16W
PD01	RU33		nsp	00MNN05101610	100 OHM +- 5% 1/16W	100 OHM +- 5% 1/16W
PD01	RU35		nsp	00MNN05103610	10K OHM +- 5% 1/16W	10K OHM +- 5% 1/16W
PD01	RU36		nsp	00MNN05473610	47K OHM +- 5% 1/16W	47K OHM +- 5% 1/16W
PD01	RU37		nsp	00MNN05473610	47K OHM +- 5% 1/16W	47K OHM +- 5% 1/16W
PD01	RU38		nsp	00MNN05473610	47K OHM +- 5% 1/16W	47K OHM +- 5% 1/16W
PD01	RU61		nsp	00MNN05472610	4.7K OHM +- 5% 1/16W	4.7K OHM +- 5% 1/16W
PD01	RU62		nsp	00MNN05122610	1.2K OHM +- 5% 1/16W	1.2K OHM +- 5% 1/16W
PD01	RU63		nsp	00MNN05122610	1.2K OHM +- 5% 1/16W	1.2K OHM +- 5% 1/16W
PD01	RU64		nsp	00MNN05102610	1K OHM +- 5% 1/16W	1K OHM +- 5% 1/16W
PD01	RU65		nsp	00MNN05222610	2.2K OHM +- 5% 1/16W	2.2K OHM +- 5% 1/16W
PD01	RU66		nsp	00MNN05222610	2.2K OHM +- 5% 1/16W	2.2K OHM +- 5% 1/16W
PD01	RU67		nsp	00MNN05103610	10K OHM +- 5% 1/16W	10K OHM +- 5% 1/16W
PD01	RU68		nsp	00MNN05103610	10K OHM +- 5% 1/16W	10K OHM +- 5% 1/16W
PD01	RU69		nsp	00MNN05103610	10K OHM +- 5% 1/16W	10K OHM +- 5% 1/16W
PD01	RU70		nsp	00MNN05103610	10K OHM +- 5% 1/16W	10K OHM +- 5% 1/16W
PD01	RU71		nsp	00MNN05103610	10K OHM +- 5% 1/16W	10K OHM +- 5% 1/16W
PD01	RU72		nsp	00MNN05821610	820 OHM +- 5% 1/16W	820 OHM +- 5% 1/16W
PD01	RU81		nsp	00MNN05472610	4.7K OHM +- 5% 1/16W	4.7K OHM +- 5% 1/16W
PD01	RU82		nsp	00MNN05122610	1.2K OHM +- 5% 1/16W	1.2K OHM +- 5% 1/16W
PD01	RU83		nsp	00MNN05122610	1.2K OHM +- 5% 1/16W	1.2K OHM +- 5% 1/16W
PD01	RU84		nsp	00MNN05102610	1K OHM +- 5% 1/16W	1K OHM +- 5% 1/16W
PD01	RU85		nsp	00MNN05222610	2.2K OHM +- 5% 1/16W	2.2K OHM +- 5% 1/16W
PD01	RU86		nsp	00MNN05222610	2.2K OHM +- 5% 1/16W	2.2K OHM +- 5% 1/16W
PD01	RU87		nsp	00MNN05103610	10K OHM +- 5% 1/16W	10K OHM +- 5% 1/16W
PD01	RU88		nsp	00MNN05103610	10K OHM +- 5% 1/16W	10K OHM +- 5% 1/16W
PD01	RU89		nsp	00MNN05103610	10K OHM +- 5% 1/16W	10K OHM +- 5% 1/16W
PD01	RU90		nsp	00MNN05821610	820 OHM +- 5% 1/16W	820 OHM +- 5% 1/16W
PD01	SU61		00MSP01013370	00MSP01013370	EVQ11L05R H/5MM 160GF	EVQ11L05R H/5MM 160GF
PD01	SU62		00MSP01013370	00MSP01013370	EVQ11L05R H/5MM 160GF	EVQ11L05R H/5MM 160GF
PD01	SU63		00MSP01013370	00MSP01013370	EVQ11L05R H/5MM 160GF	EVQ11L05R H/5MM 160GF

NOTE : "nsp" PART IS LISTED FOR REFERENCE ONLY, D&M WILL NOT SUPPLY THESE PARTS.

PCB NAME	POS. NO.	VERS. COLOR	PART NO. (FOR EUR)	PART NO. (MJJ)	PART NAME	DESCRIPTION
PD01	SU71		00MSP01013370	00MSP01013370	EVQ11L05R H/5MM 160GF	EVQ11L05R H/5MM 160GF
PD01	SU72		00MSP01013370	00MSP01013370	EVQ11L05R H/5MM 160GF	EVQ11L05R H/5MM 160GF
PD01	SU73		00MSP01013370	00MSP01013370	EVQ11L05R H/5MM 160GF	EVQ11L05R H/5MM 160GF
PD01	XU01		00MFG08004060	00MFG08004060	CSTS MG 8MHZ TAPING(15PF)	CSTS MG 8MHZ TAPING(15PF)
					IR SENSOR PWB(00MWG27AJ302-)	
PD31	CD01		nsp	00MDK98104200	GRM39F104Z16 0.1UF MURATA	GRM39F104Z16 0.1UF MURATA
PD31	CD02		nsp	00MDK96102300	1000 PF +- 10 % B 50V GR36	1000 PF +- 10 % B 50V GR36
PD31	CD03		nsp	00MDK96102300	1000 PF +- 10 % B 50V GR36	1000 PF +- 10 % B 50V GR36
PD31	CD04		nsp	00MDK96102300	1000 PF +- 10 % B 50V GR36	1000 PF +- 10 % B 50V GR36
PD31	CD05		nsp	00MDK96102300	1000 PF +- 10 % B 50V GR36	1000 PF +- 10 % B 50V GR36
PD31	CD06		nsp	00MDK98104200	GRM39F104Z16 0.1UF MURATA	GRM39F104Z16 0.1UF MURATA
PD31	CD07		nsp	00MDK98474200	GRM39F474Z16PT 0.47UF F 16V	GRM39F474Z16PT 0.47UF F 16V
PD31	CD08		nsp	00MDK98474200	GRM39F474Z16PT 0.47UF F 16V	GRM39F474Z16PT 0.47UF F 16V
PD31	CD09		nsp	00MDK98474200	GRM39F474Z16PT 0.47UF F 16V	GRM39F474Z16PT 0.47UF F 16V
PD31	CD10		nsp	00MDK98474200	GRM39F474Z16PT 0.47UF F 16V	GRM39F474Z16PT 0.47UF F 16V
PD31	CD12		nsp	00MDK98474200	GRM39F474Z16PT 0.47UF F 16V	GRM39F474Z16PT 0.47UF F 16V
PD31	CD13		00MEG10601650	00MEG10601650	10UF/ 16V	10UF/ 16V
PD31	CU23		nsp	00MDK98104200	GRM39F104Z16 0.1UF MURATA	GRM39F104Z16 0.1UF MURATA
PD31	CU24		00MEJ10700610	00MEJ10700610	100UF/6.3V	100UF/6.3V
PD31	CU26		00MEG10601650	00MEG10601650	10UF/ 16V	10UF/ 16V
PD31	CU27		00MEG10601650	00MEG10601650	10UF/ 16V	10UF/ 16V
PD31	DU01		00MHI10005340	00MHI10005340	HLMF-K200 #2UL RED H=9 3MM	HLMF-K200 #2UL RED H=9 3MM
PD31	DU02		263710014404S	263710014404S	SELT2E10C-S TP6 F/G RANK	SELT2E10C-S TP6 F/G RANK
PD31	JD01		00MYJ07061070	00MYJ07061070	14FMN-BTK-A	14FMN-BTK-A
PD31	JD02		00MYJ07060290	00MYJ07060290	11FMN-BTK-A	11FMN-BTK-A
PD31	QD02		00MHX300012A0	00MHX300012A0	2SC4081 (Q R) 2SC4116 (Y GR)	2SC4081 (Q R) 2SC4116 (Y GR)
PD31	QU05		00MBA21303000	00MBA21303000	DTC124EU RN1303 UMT TYPE	DTC124EU RN1303 UMT TYPE
PD31	QU06		00MBA21303000	00MBA21303000	DTC124EU RN1303 UMT TYPE	DTC124EU RN1303 UMT TYPE
PD31	QU11		00MHW10004210	00MHW10004210	RPM6936-V4 (IR SENSOR)	RPM6936-V4 (IR SENSOR)
PD31	RD01		nsp	00MNN05223610	22K OHM +- 5% 1/16W	22K OHM +- 5% 1/16W
PD31	RD03		nsp	00MNN05102610	1K OHM +- 5% 1/16W	1K OHM +- 5% 1/16W
PD31	RD05		nsp	00MNN05102610	1K OHM +- 5% 1/16W	1K OHM +- 5% 1/16W
PD31	RD06		nsp	00MNN05102610	1K OHM +- 5% 1/16W	1K OHM +- 5% 1/16W
PD31	RD07		nsp	00MNN05102610	1K OHM +- 5% 1/16W	1K OHM +- 5% 1/16W
PD31	RD08		nsp	00MNN05472610	4.7K OHM +- 5% 1/16W	4.7K OHM +- 5% 1/16W
PD31	RD09		nsp	00MNN05392610	3.9K OHM +- 5% 1/16W	3.9K OHM +- 5% 1/16W
PD31	RD12		nsp	00MNN05000610	0 OHM +- 5% 1/16W	0 OHM +- 5% 1/16W
PD31	RU08		nsp	00MNN05331610	330 OHM +- 5% 1/16W	330 OHM +- 5% 1/16W
PD31	RU09		nsp	00MNN05103610	10K OHM +- 5% 1/16W	10K OHM +- 5% 1/16W
PD31	RU10		nsp	00MNN05222610	2.2K OHM +- 5% 1/16W	2.2K OHM +- 5% 1/16W
PD31	RU11		nsp	00MNN05103610	10K OHM +- 5% 1/16W	10K OHM +- 5% 1/16W
PD31	RU34		nsp	00MNN05101610	100 OHM +- 5% 1/16W	100 OHM +- 5% 1/16W
					BACK LIGHT PWB(00MWG27AJ305-)	
PD41	CD11		nsp	00MDK98104200	GRM39F104Z16 0.1UF MURATA	GRM39F104Z16 0.1UF MURATA
PD41	DD11		00MHI10005980	00MHI10005980	NSPW515BS-S-CO	NSPW515BS-S-CO
PD41	JD11		00MYJ06006220	00MYJ06006220	B2B-PH-K-S (LF)(SN)	B2B-PH-K-S (LF)(SN)
PD41	RD11		nsp	00MNN05103610	10K OHM +- 5% 1/16W	10K OHM +- 5% 1/16W
					SELECTOR PWB(00MWG27AJ304-)	
PD61	CU81		nsp	00MDK96103300	0.01UF +-10% 50V C1608JB1H103K	0.01UF +-10% 50V C1608JB1H103K
PD61	CU82		nsp	00MDK96103300	0.01UF +-10% 50V C1608JB1H103K	0.01UF +-10% 50V C1608JB1H103K
PD61	JU31		00MYP06003930	00MYP06003930	S3B-EH	S3B-EH
PD61	SU82		00MSR01120070	00MSR01120070	SRRSIC	SRRSIC
					VOLUME PWB(00MWG27AJ303-)	
PD71	JU21		00MYP06003940	00MYP06003940	S4B-EH	S4B-EH
PD71	RU57		nsp	00MNN05103610	10K OHM +- 5% 1/16W	10K OHM +- 5% 1/16W
PD71	RU58		nsp	00MNN05103610	10K OHM +- 5% 1/16W	10K OHM +- 5% 1/16W
PD71	RU59		nsp	00MNN05103610	10K OHM +- 5% 1/16W	10K OHM +- 5% 1/16W
PD71	RU60		nsp	00MNN05103610	10K OHM +- 5% 1/16W	10K OHM +- 5% 1/16W
PD71	SU81		00MSR02010120	00MSR02010120	EC12E2430804	EC12E2430804

NOTE : "nsp" PART IS LISTED FOR REFERENCE ONLY, D&M WILL NOT SUPPLY THESE PARTS.

PCB NAME	POS. NO.	VERS. COLOR	PART NO. (FOR EUR)	PART NO. (MJI)	PART NAME	DESCRIPTION
					HDAM-SA2D PWB(00MWA27AJ601-)	
PS01	JS01		00MYP07005670	00MYP07005670	IMSA-6065B-06Z065-PT1	IMSA-6065B-06Z065-PT1
PS01	QS01		00MHT600121A0	00MHT600121A0	KTA1268 PNP TRANSISTOR RANK=GR	KTA1268 PNP TRANSISTOR RANK=GR
PS01	QS02		00MHT800931A0	00MHT800931A0	KTC3200 NPN TRANSISTOR RANK=GR	KTC3200 NPN TRANSISTOR RANK=GR
PS01	QS03		00MHT800931A0	00MHT800931A0	KTC3200 NPN TRANSISTOR RANK=GR	KTC3200 NPN TRANSISTOR RANK=GR
PS01	QS04		00MHT600121A0	00MHT600121A0	KTA1268 PNP TRANSISTOR RANK=GR	KTA1268 PNP TRANSISTOR RANK=GR

NOTE : "hsp" PART IS LISTED FOR REFERENCE ONLY, D&M WILL NOT SUPPLY THESE PARTS.

14. AFTER REPLACEMENT OF U-PRO OR FLASH ROM

When replaced of the U-PRO (Microprocessor) or the Flash ROM, confirm contents of the following.

PWB Name	Pos. No.	Description	After replaced	Remark
PD01	QU01	HD64F3687H FLASH	C	

After replaced

A : Mask ROM (With software). No need write-in of software to the microprocessor.

B : Flash ROM (With software). Usually, no need write-in of software. But, when the software was updated, you should be write-in of the new software to the microprocessor or flash ROM. Please check the software version.

C : Empty Flash ROM (Without software). You should be write-in of the software to the microprocessor or flash ROM. Refer to "Update procedure" or "writing procedure", when you should be write-in the software.

U-PRO(マイコン)およびFlash ROM等の修理交換後の対応について

U-PRO (マイコン)およびFlash ROM等を交換した場合の対応方法を下記に記載します。

PWB Name	Pos. No.	Description	交換時の対応	備考
PD01	QU01	HD64F3687H FLASH	C	

交換時の対応

A : Mask ROM (ソフトウェア書き込み済み) 交換時にソフトウェアの書き込みは必要ありません。

B : Flash ROM (ソフトウェア書き込み済み) バージョンアップにより交換時にソフトウェアの書き換えが必要な場合があります。バージョンの確認をしてください。

C : 空ROM (Flash ROM) 交換時必ずソフトウェアの書き込みが必要になります。Update、書き込み方法を参照してください。