

8

**SERVICE
MANUAL** **PM225**

SYSTEM DC525/DC525L/DC325/DC325L

marantz[®]

model PM225

Stereophonic Amplifier

MARANTZ DESIGN AND SERVICE

Using superior design and selected high grade components, MARANTZ Company has created the ultimate in stereo sound. Only original MARANTZ parts can insure that your MARANTZ product will continue to perform to the specifications for which it is famous.

Parts for your MARANTZ stereo are generally available within 72 hours throughout the nation via a toll-free line to our National Parts Depot in California. The sales professionals who take your call immediately refer to their own desk top computer terminal and can quickly determine the availability and price information you require. If, for some reason, your order should exceed our available stock, we usually can instantly provide an alternate replacement part or current delivery information. When the order is placed and confirmed, the computer simultaneously generates "hard copy" orders at the distribution center. As hard copies come directly from the computer to the national parts depot, your requested stock is assembled and prepared for shipment and placed on the first available carrier for delivery to you.

ORDERING PARTS

Phone orders will eliminate mail delays, and we encourage the use of this method. If you order by mail, use MARANTZ parts order forms which are available from our National Parts Depot located at the following address:

SUPERSCOPE NATIONAL PARTS DEPARTMENT
20525 Nordhoff Street
Chatsworth, California 91311
Phone: 1-800-423-5108
1-213-998-9333

The following information must be supplied to eliminate delays in processing your order:

1. Complete address.
2. Complete part numbers.
3. Complete description of parts.
4. Model number for which part is required (indicate MARANTZ).
5. Account number (for account customers only).

Direct consumers will be provided with the current retail price quotation on available parts in order to advise them of the cost of the parts and shipping.

OVERSEAS PARTS ORDERING

Parts may also be ordered from the following overseas addresses:

U.S.A.	CANADA	AUSTRALIA	JAPAN
MARANTZ COMPANY, INC. National Service Dept. P.O. Box 577 Chatsworth, CA 91311 U.S.A.	SUPERSCOPE CANADA, LTD. 3710 Nashua Drive Mississauga Ontario, Canada L4V1M5	MARANTZ AUSTRALIA 32 Cross Street Brookvale, NSW 2100 Australia	MARANTZ JAPAN, INC. 3622 Kamitsuruma Sagamihara-shi Kanagawa, Japan
EUROPE			
MARANTZ S.A. 326 Avenue Louise Bte 32 1050 Brussels Belgium	MARANTZ AUDIO U.K. LTD. Unit 15/16 Saxon Way Industrial Estate Motor Lane Harmondsworth UB7 OLW Great Britain	MARANTZ BELGIUM 45 Rue Auguste Van Zande 1080 Brussels Belgium	MARANTZ SVENSKA A.B. Svartviksvangen 56 Traneberg Box 12016 161 12 BROMMA SWEDEN
MARANTZ GERMANY GMBH Max-Planckstrasse 22 6072 Dreieich 1 West Germany	MARANTZ FRANCE 4 Rue Bernard Palissy 92600 Asnieres France	MARANTZ AUSTRALIA PTY., LTD. 32 Cross Street Brookvale, N.S.W. 2100 Australia	
	MARANTZ NORSKE A.S. Refstadalleen 13 Oslo 5 Norway	MARANTZ DENMARK Bregnerødvej 132b 3460 BIRKERØD DENMARK	

All of the above locations are fully equipped to take care of your total service needs. Because various countries have differing configuration requirements, it is necessary that you contact the service facility in your particular country. In the event that there is no service location listed for your country, please contact the nearest facility for the necessary assistance.

marantz®

TABLE OF CONTENTS

SECTION	PAGE
SYSTEM CONNECTION	1
INTRODUCTION	2
1. SHOCK, FIRE HAZARD SERVICE TEST	2
2. PRE-AMPLIFIER	2
3. MAIN AMPLIFIER	2
4. POWER AMPLIFIER ADJUSTMENT	2
5. POWER LED METER ADJUSTMENT	2
6. TEST EQUIPMENT REQUIRED FOR SERVICING	3
7. PERFORMANCE VERIFICATION	3
8. VOLTAGE CONVERSION	6
9. BLOCK DIAGRAM	7
10. DIAGRAM AND COMPONENT LOCATIONS	8
10.1 Main Amp Assembly (P700) Schematic Diagram and Component Locations	8
10.2 Power Tr. Assembly (P701) Schematic Diagram and Component Locations	8
10.3 Power Tr. Assembly (P702) Schematic Diagram and Component Locations	8
10.4 AC Switch Assembly (P000) Schematic Diagram and Component Locations	8
10.5 Tone Control Assembly (PE00) Schematic Diagram and Component Locations	11
10.6 LED Level Meter Drive Assembly (PX01) Schematic Diagram and Component Locations	11
10.7 LED Level Meter Assembly (PX02) Schematic Diagram and Component Locations	12
10.8 Head Phone Assembly (PW00) Schematic Diagram and Component Locations	12
11. EXPLODED VIEW AND PARTS LIST	13
12. ELECTRICAL PARTS LIST	19
13. TECHNICAL SPECIFICATIONS	23
14. SCHEMATIC DIAGRAM	24

(DC525/DC525L & DC325/DC325L)

SYSTEM CONNECTION

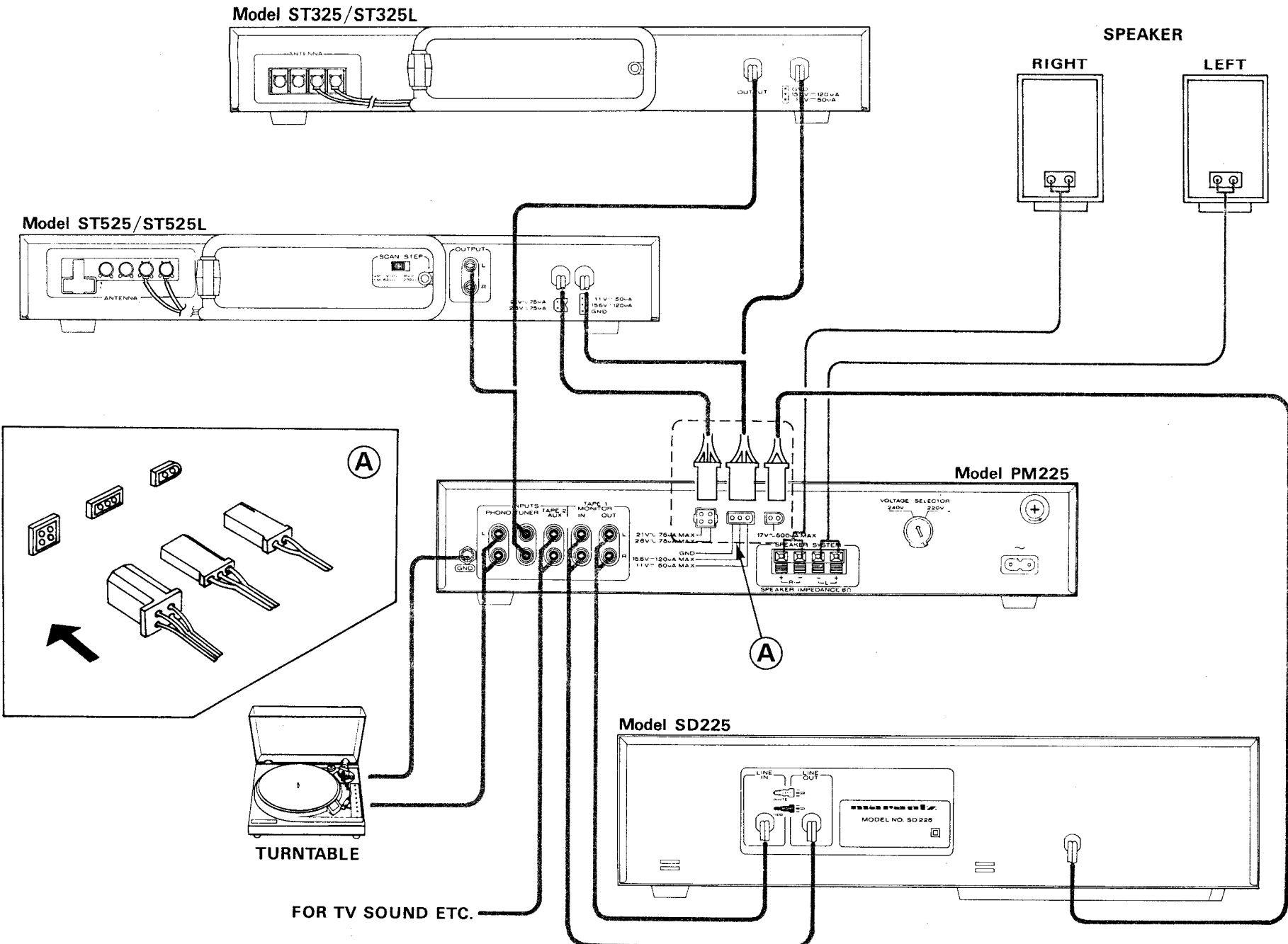
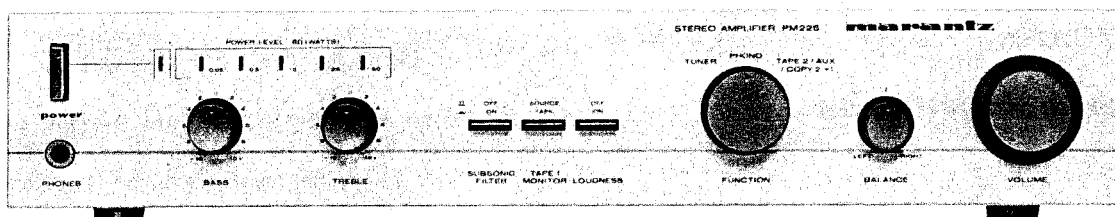

Figure 3. System Connection
Figure 3. Raccordement du Système
Abbildung 3. Ansluß des Systems

MODEL PM 225 STEREO AMPLIFIER



INTRODUCTION

This service manual was prepared for use by Authorized Warranty Stations and contains service information for the Marantz Model PM225 Stereo Console Amplifier. Servicing information and voltage data included in this manual are intended for use by knowledgeable and experienced personnel only. All instructions should be read carefully. No attempt should be made to proceed without a good understanding of circuitry operation.

The parts list furnishes complete ordering information. Most replacement parts should be ordered from the Marantz Company. However, a simple description is included for parts which can be obtained locally.

1. SHOCK, FIRE HAZARD SERVICE TEST

CAUTION: After servicing this appliance and prior to returning to customer, either primary AC cord connector pins (with unit NOT connected to AC mains and its Power switch ON), and the face or front Panel of product and controls and chassis bottom.

Any resistance measurement less than 1 Megohms should cause unit to be repaired or corrected before AC power is applied and verified before return to user/customer.

Ref. UL Standard NO, 1270. Para.66. 3. D (Mandatory Test after servicing Electrical Appliances, effective 7-1-83).

2. PRE-AMPLIFIER

Signals from the TUNER and AUX terminals are taken to the SELECTOR SWITCH (SS02).

Signals from the PHONO terminals pass through the phono amplifier (Q401) where they are amplified by 35.5dB and at the same time undergo RIAA equalization, before going to the SELECTOR SWITCH (SS02).

After being selected by the SELECTOR SWITCH, the incoming signals are taken to the TAPE MONITOR SWITCH and TAPE OUT terminals.

Signals which enter from the TAPE IN terminals are taken to the TAPE MONITOR SWITCH.

Signals which are selected by the TAPE MONITOR SWITCH are taken to the BALANCE and VOLUME potentiometers, and then enter the pre-amplifier (QE01). The pre-amplifier has a gain of 20 dB and also functions as the BASS and TREBLE tone controls.

After passing through the pre-amplifier, the signals enter the main amplifier.

3. MAIN AMPLIFIER

The main amplifier contains an 6 dB/OCT type high pass filter network which can be switched in and out of circuit by means of the LOW FILTER switch.

4. POWER AMPLIFIER ADJUSTEMENT

ADJUSTMENT OF IDLING CURRENT

Connect a DC voltmeter to between emitters Q729 and Q731. Adjust R725 until 9 mV is reached. Likewise, adjust Q730, Q732 and R726.

5. POWER LED METER ADJUSTMENT

Feed 1kHz signal to the Left channel AUX jack and adjust the input signal level so that the rated power output voltage of 14.1V is obtained across the speaker terminals. Then adjust RX17 until the 5th LED just lights up. Next, apply the signal to the Right channel AUX jack, and adjust RX16 in the similar way.

Note: Do not apply the input signal to both Left and Right AUX jacks at the same time, if applied, incorrect alignment may be occurred.

6. TEST EQUIPMENT REQUIRED FOR SERVICING

Table 1 lists the test equipment required for servicing the Model PM225 Stereo Console Amplifier. The wattmeter, AC voltmeter, and variable autotransformer may be assembled as a test fixture as shown schematically in Figure 1. The load resistors and AC ammeter may be assembled into a second test fixture as shown in Figure 2.

Line Switch	OFF
Variable-line switch	Variable
Wattmeter Switch	ON
Variable Autotransformer	0 V (fully CCW)
Load	8 ohms (0.5 mfd—OFF)
Audio Generator	1 kHz
Output	5 V range
Gain	Minimum
AC Voltmeter	30 V range

7. PERFORMANCE VERIFICATION

TEST PROCEDURE

A. TEST EQUIPMENT

Refer to Table 1 for required test equipment.

B. PRELIMINARY PROCEDURES

1. Make the test setup shown in Figure 1 with the instrument controls set in the following positions:
2. Make sure that connections between the resistive load and the system terminals of the Model PM225 have negligible resistance when compared with the resistance of the load itself. Appreciable resistance in wiring adds to the total load, resulting in inaccurate measurements of output power.
3. Connect amplifier output to load and connect AC cord to line power. Connect shorting plugs to the Phono input jacks of the Model PM225.

Table 1. Test Equipment Required for Servicing

Item	Manufacturer and Model No.	Use
Distortion Analyzer Audio Oscillator AC Voltmeter	Sound Technology Model 1700B	Distortion Measurements Sinewave and squarewave signal source voltage measurements (AC)
Oscilloscope	Tektronix Model T932 Philips Model 3232	Waveform analysis and trouble shooting and ASO alignment
Circuit Tester		Trouble shooting
DC Voltmeter	Fluke Model 8000 "Digital" Simpson Model 313, Triplet Model 801	Voltage measurements (DC)
AC Wattmeter	Simpson Model 1379	Monitors primary power to amplifier
AC Ammeter	Commercial Grade (1 ~ 10 A)	Monitors amplifier output under short circuit condition
Line Voltmeter	Simpson Model 1359	Monitors potential of primary power to amplifier
Variable Autotransformer	Superior Electronic Co., Powerstet Model 116B-10A	Adjusts level of primary power to amplifier
Shorting Plug	Use phono plug with 600 ohm across center pin and shell	Shorts amplifier input to eliminate noise pickup
Output Load (8 ohms, ±0.5% 100 W)	Commercial Grade	Provides 8-ohm load for amplifier output termination
Output Load (4 ohms, ±0.5% 100 W)	Commercial Grade	Provides 4-ohm load for amplifier output termination
Output Load Capacitor (0.5 mfd)	Mylar	Provides capacitive load for instability checks
AC Power Control Box	Optional Item. Fabricate in accordance with Figure 1	Monitors and controls primary power for amplifier
Amplifier Output Load Box	Optional Item. Fabricate in accordance with Figure 2	Provides various amplifier loads and can monitor shorted output

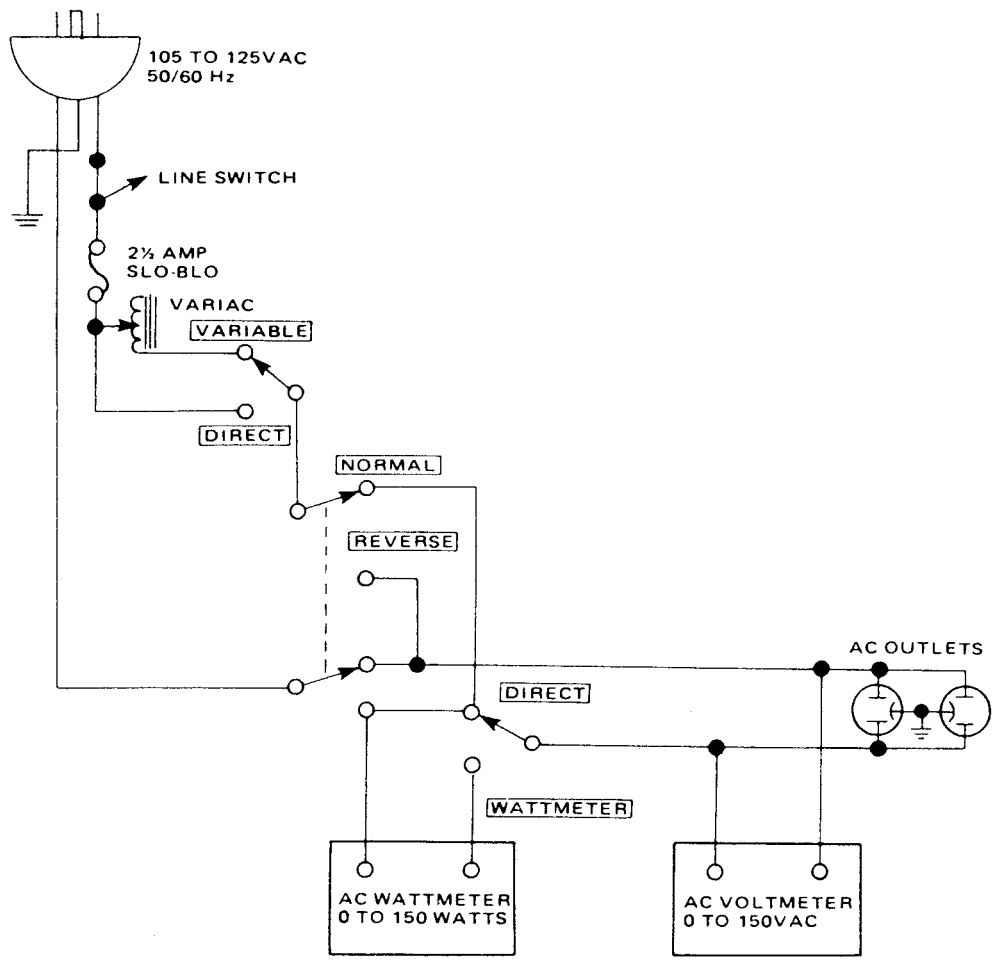

Figure 1. AC Power Control Box Simplified Schematic

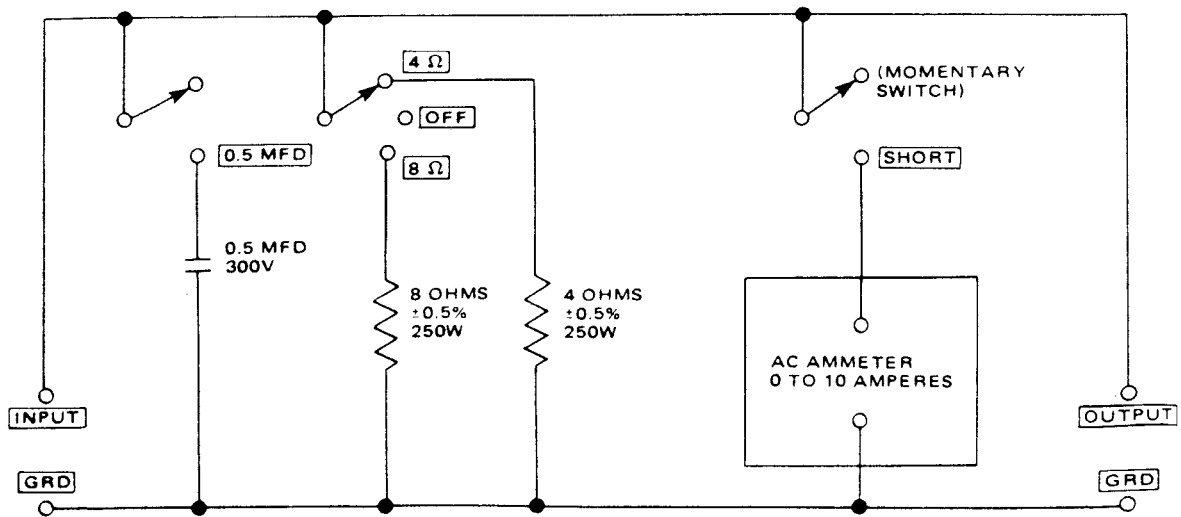

Figure 2. Amplifier Output Load Box Simplified Schematic

C. TOTAL HUM AND NOISE TEST

1. With shorting plugs connected to the Phono input jacks and an 8 ohm resistive load connected across the speaker system output terminals, connect a distortion analyzer across the load.

NOTE:

If the distortion analyzer does not contain a built-in voltmeter, an AC VTVM may be substituted.

2. Set the distortion analyzer controls for voltage measurements and apply power to the amplifier. Set the volume control fully CCW. Set the SELECTOR switch to PHONO.
3. If the distortion analyzer indicates more than 2.0 mV refer to the trouble analysis section of this manual.
4. Set the volume control fully CW. If the distortion analyzer indicates more than 20 mV, refer to the trouble analysis section of this manual.

D. MAXIMUM POWER OUTPUT

1. Connect the audio oscillator to the AUX input. Set audio oscillator frequency to 1 kHz. Set SELECTOR switch to AUX.
2. With the distortion analyzer connected across the output load (8-ohm), set the analyzer on the 30 VAC scale.
3. Turn the analyzer on and increase the audio oscillator output to 150 mV. The AC VTVM should read 15.5 VAC or more.

E. HARMONIC DISTORTION TEST

1. Set the frequency of the audio oscillator and the distortion analyzer to 20 kHz.
2. Set the controls of the analyzer for voltage measurement on the 30 volt scale.
3. Adjust the audio oscillator output level until the analyzer meter indicates 15.5 VAC.
4. Switch the distortion analyzer to Set Level and adjust SENSITIVITY for full scale reading on 0 ~ 0.3% scale.
5. Measure the total harmonic distortion with the analyzer and verify it is less than 0.05%.

NOTE:

Any parasitic oscillation in the amplifier will be displayed on the oscilloscope when capacitance is switched into the load.

6. Switch the distortion analyzer back to SET LEVEL. (Do not readjust sensitivity of analyzer.)
7. Change the frequency of the audio oscillator and distortion analyzer to 1 kHz. Adjust audio oscillator output for a full scale reading on the 0 ~ 1% scale.
8. Measure the distortion, verifying it is no greater than 0.05%.
9. Repeat steps 7 and 8, changing frequency to 20 Hz. Distortion should be no more than 0.05%.
10. Check for parasitic oscillation; there should be none.

Note on safety:

Symbol \triangle Fire or electrical shock hazard. Only original parts should be used to replace any part marked with symbol \triangle . Any other component substitution (other than original type), may increase risk of fire or electrical shock hazard.

8. VOLTAGE CONVERSION

• EUROPEAN MODEL ONLY

To convert the unit to a different power source voltage, change the position as illustrated in the drawing below.

CAUTION
DISCONNECT POWER SUPPLY CORD FROM AC OUTLET BEFORE CONVERTING VOLTAGE.

Voltage Conversion Chart

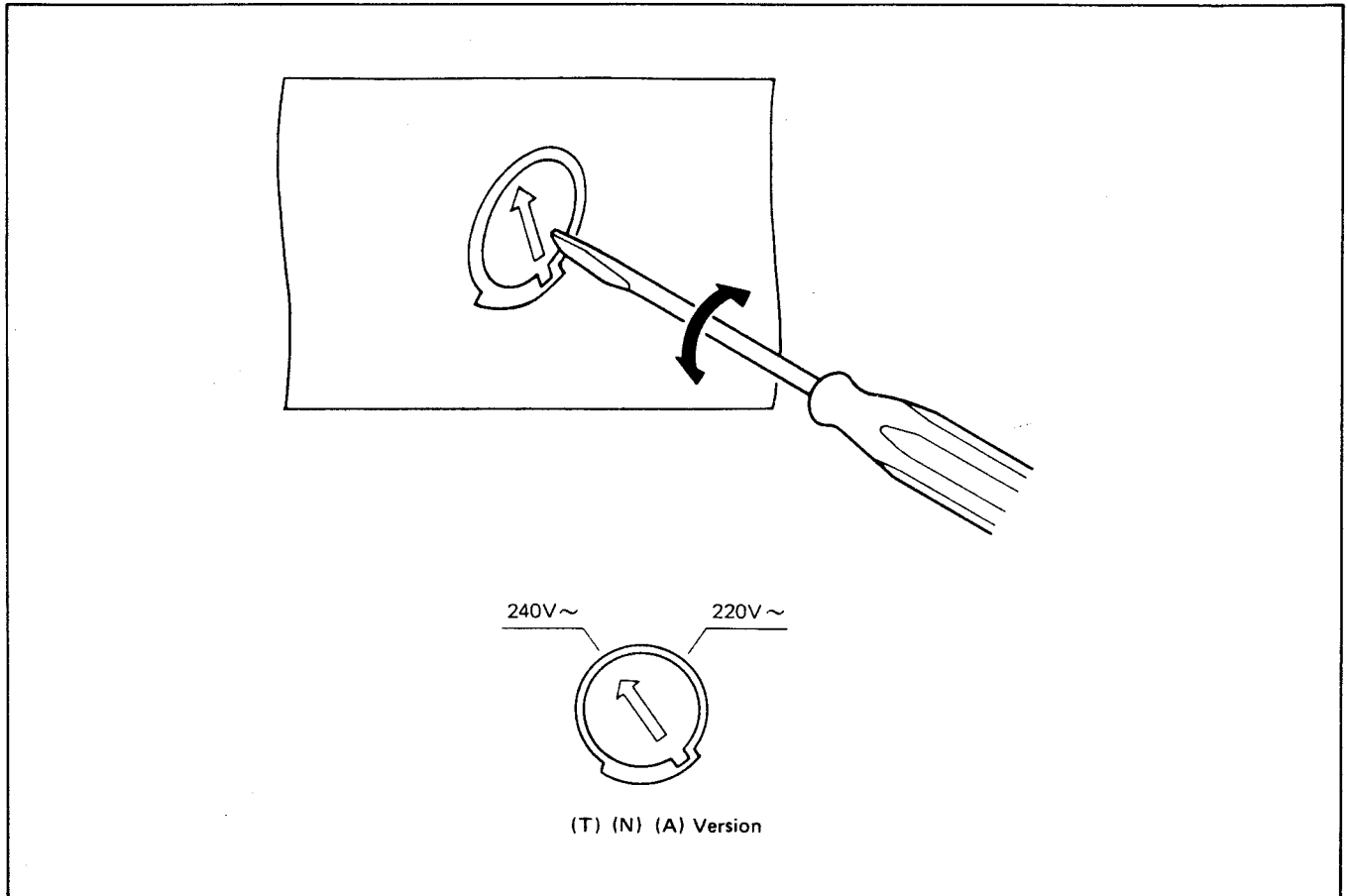

9. BLOCK DIAGRAM

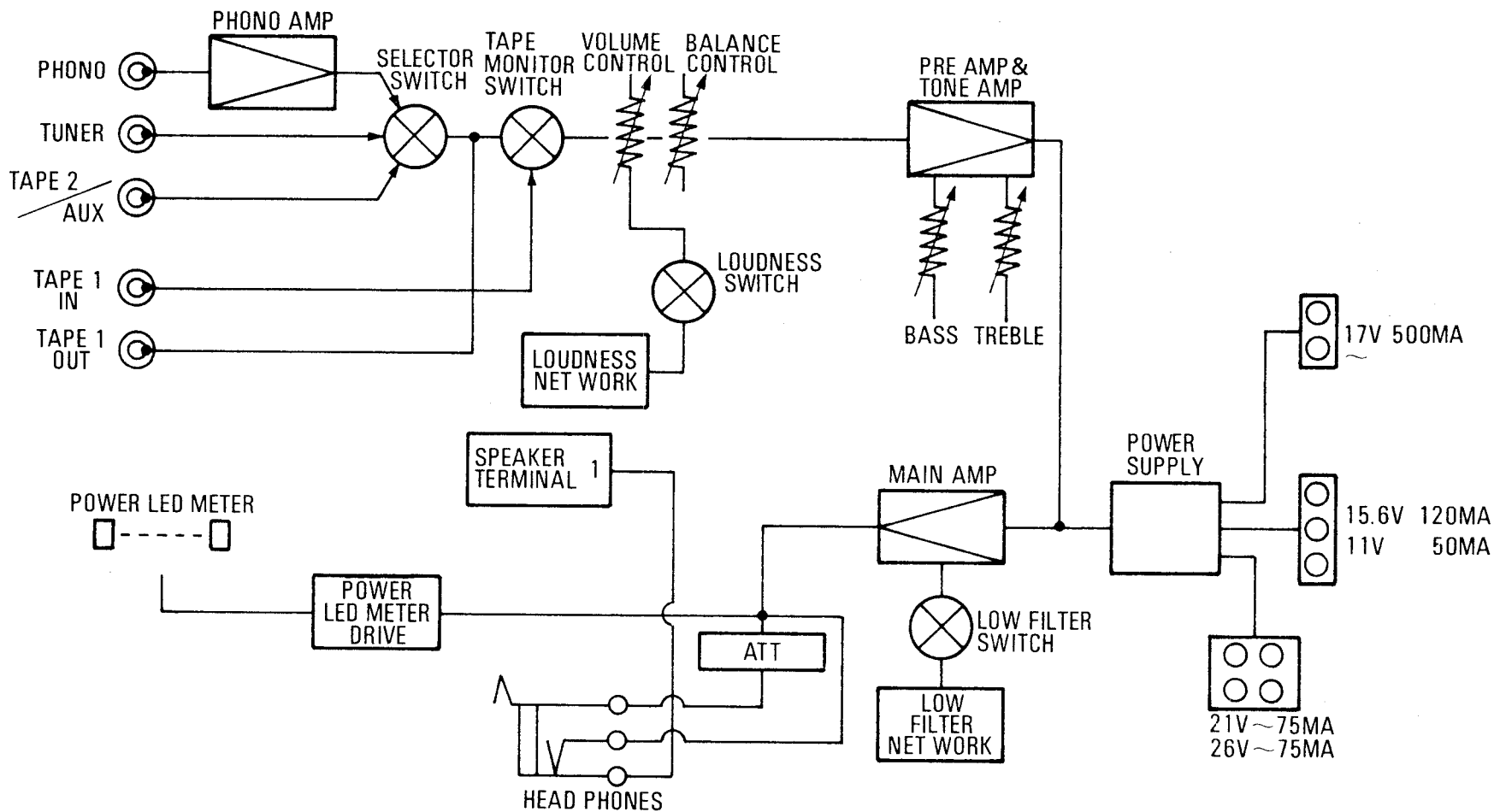

10. DIAGRAM AND COMPONENT LOCATIONS

10.1 Main Amp Assembly (P700) Schematic Diagram and Component Locations

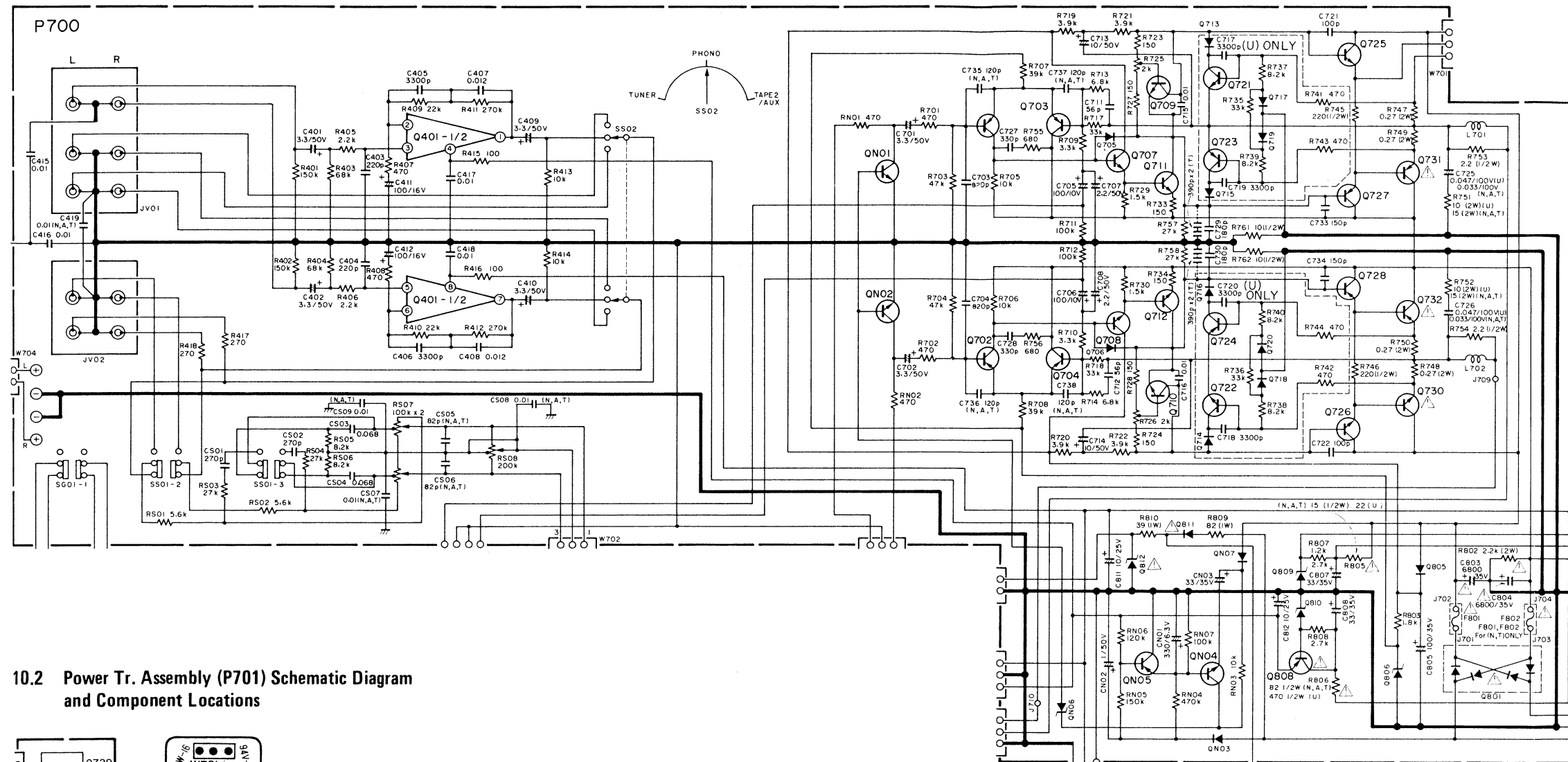

10.2 Power Tr. Assembly (P701) Schematic Diagram and Component Locations

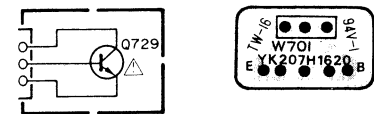

10.3 Power Tr. Assembly (P702) Schematic Diagram and Component Locations

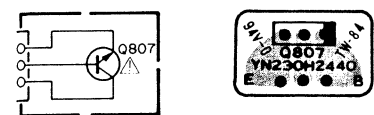

10.4 AC Switch Assembly (P000) Schematic Diagram and Component Locations

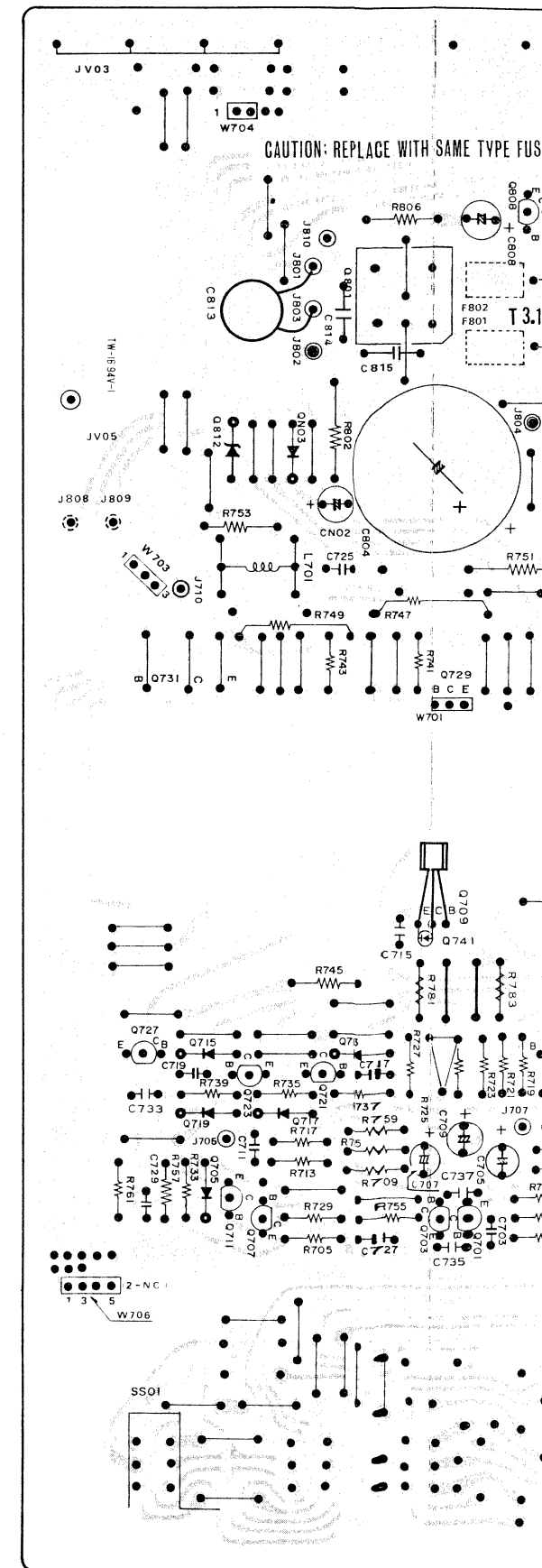
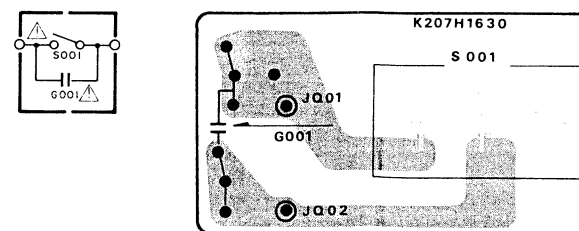

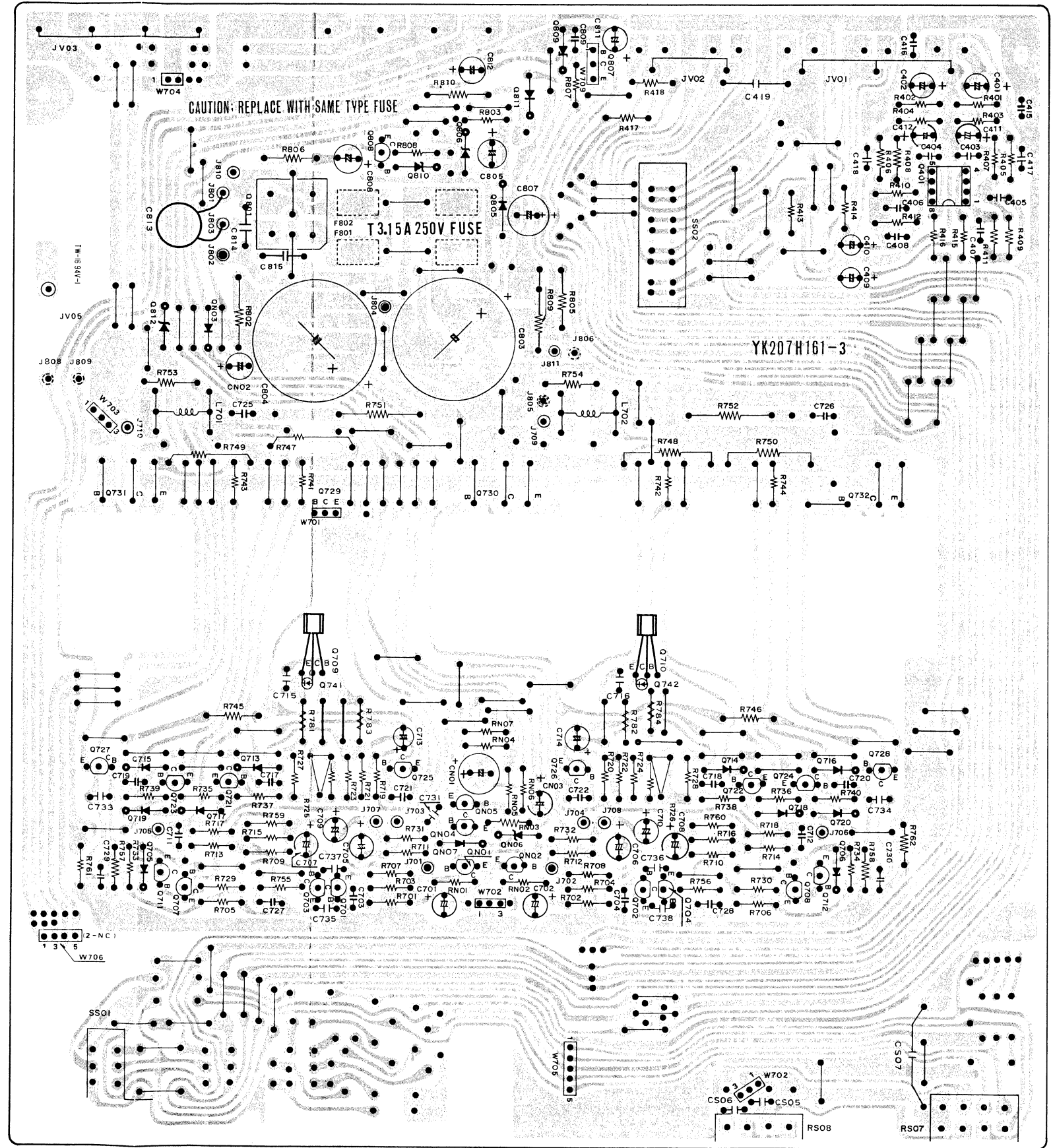
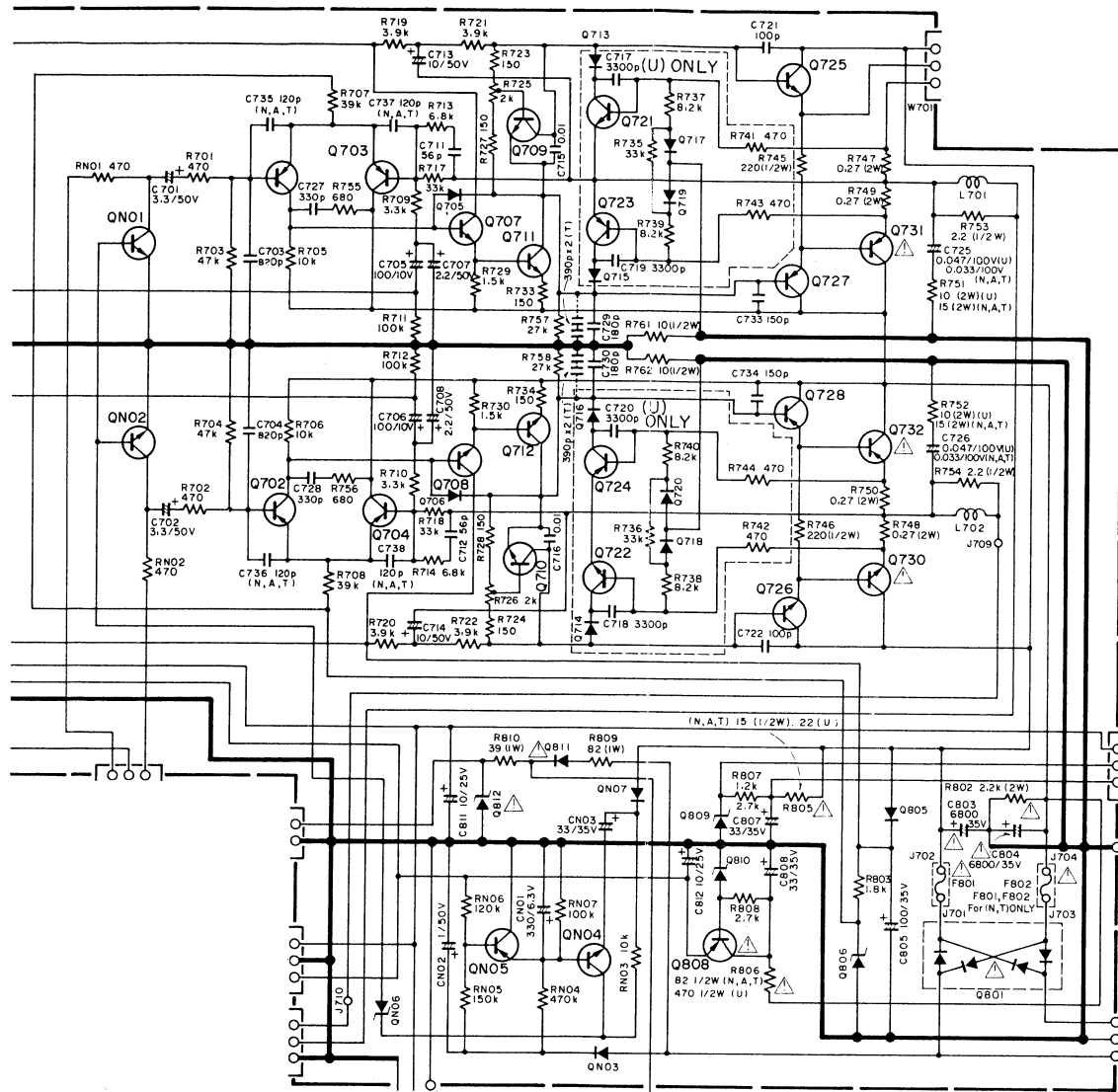

AC Switch Assembly (PO00) Schematic Diagram and Component Locations

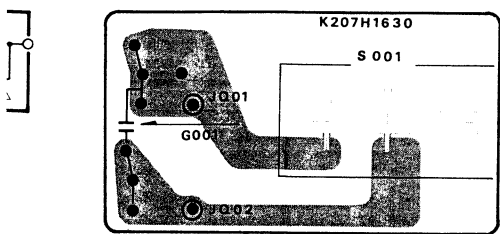

5 Tone Control Assembly (PE00) Schematic Diagram and Component Locations

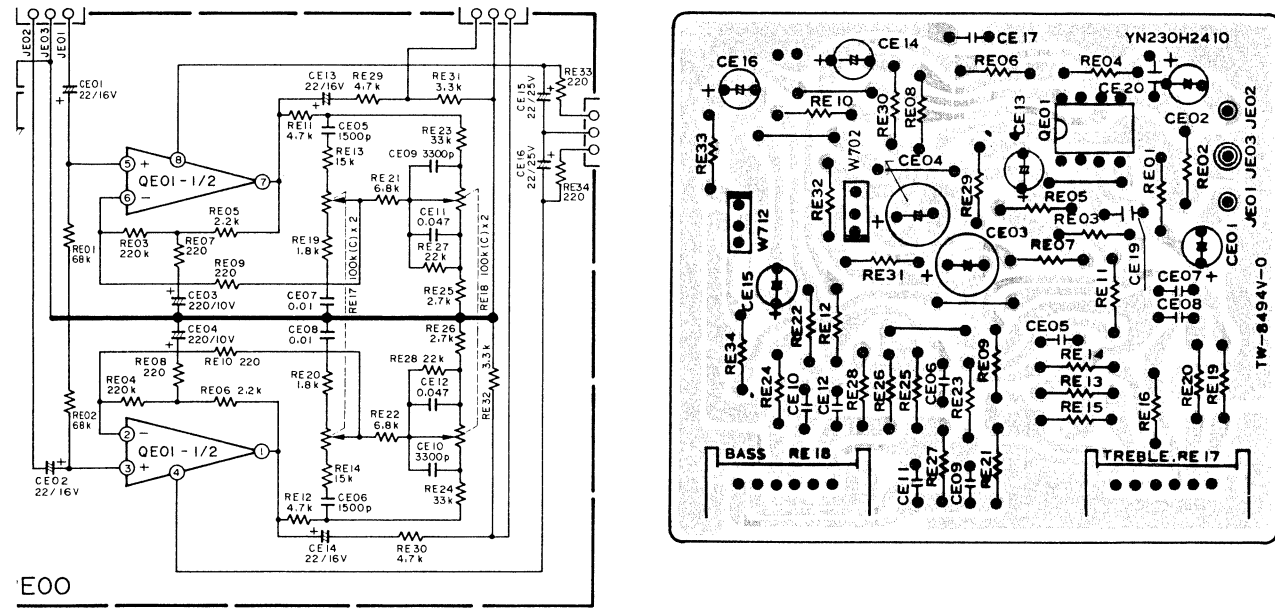

10.7 LED Level Meter Assembly (PX02) Schematic Diagram and Component Locations

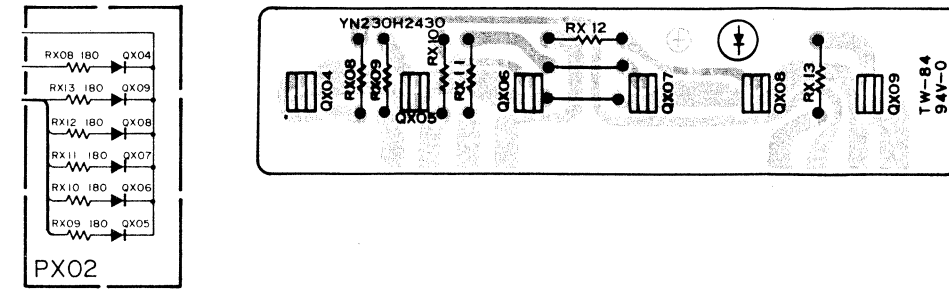

6 LED Level Meter Drive Assembly (PX01) Schematic Diagram and Component Locations

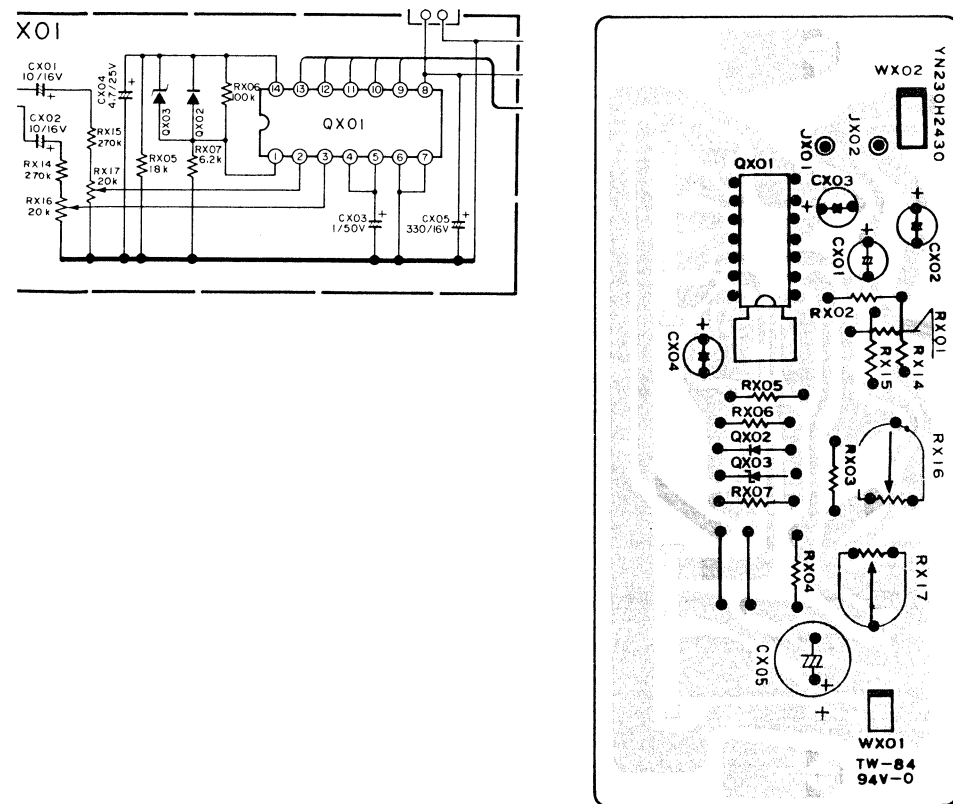

10.8 Head Phone Assembly (PW00) Schematic Diagram and Component Locations

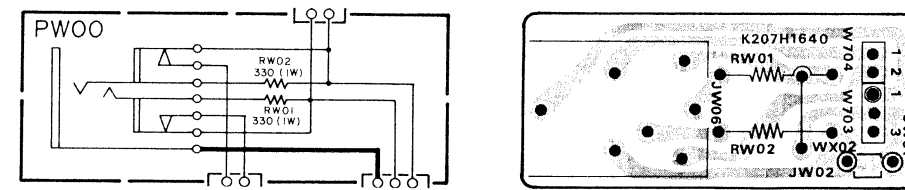

11. EXPLODED VIEW

- [C01-99] Front Panel

REF. DESIG.	QTY			PA
	U	N	A	
A	1	1	1	230H
01B	1	1	1	230H
02B	1	1	1	234H
03B	2	2	2	234H
04B	3	3	3	208H
01B	1	1	1	114H



10.7 LED Level Meter Assembly (PX02) Schematic Diagram and Component Locations

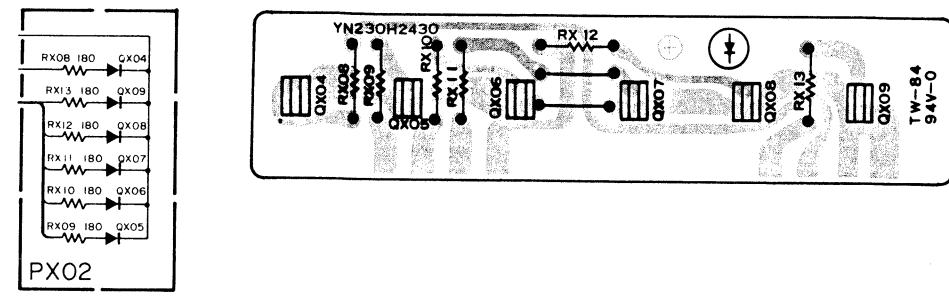

10.8 Head Phone Assembly (PW00) Schematic Diagram and Component Locations

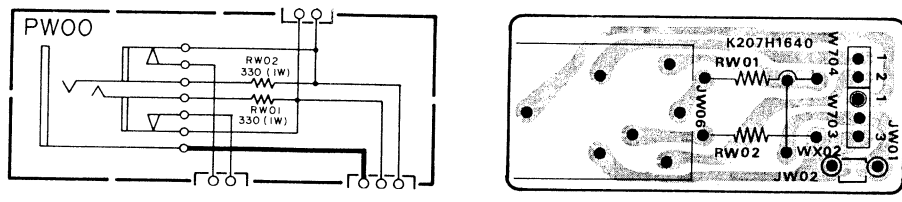

11. EXPLODED VIEW AND PARTS LIST

- [C01-99] Front Panel

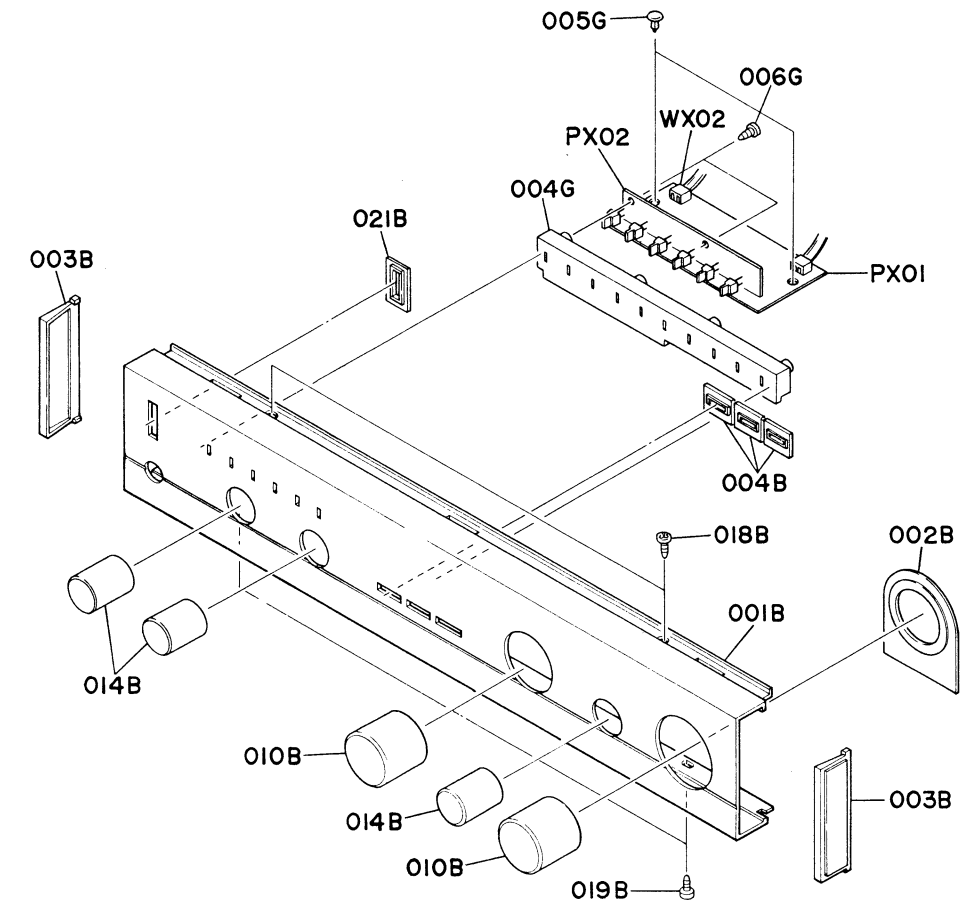

- (U) for U.S.A.
- (N) for Europe
- (A) for Australia

REF. DESIG.	Q'TY			PART NO.	DESCRIPTION
	U	N	A		
A	1	1	1	230H063400	Front Panel Assembly
001B	1	1	1	230H063010	Escutcheon, Front Panel
002B	1	1	1	234H063020	Escutcheon, Volume
003B	2	2	2	234H067010	Cap, Side
004B	3	3	3	208H259110	Bushing, Push Switch
021B	1	1	1	114H259020	Bushing, Power Switch

REF. DESIG.	Q'TY			PART NO.	DESCRIPTION
	U	N	A		
010B	2	2	2	226H154110	Knob
014B	3	3	3	226H154120	Knob
018B	2	2	2	51300306B0	P.H. Tapped Screw P3 x 6
019B	2	2	2	51300306B0	P.H. Tapped Screw P3 x 6
004G	1	1	1	234H118010	Spacer, LED
005G	2	2	2	2276005050	Clamper
006G	3	3	3	51280308B0	B.H. Tapped Screw B3 x 8
WX02	1	1	1	YU02180240	Jumper Lead (2P)

• [C02-99] Lid (Top and Bottom Cover)

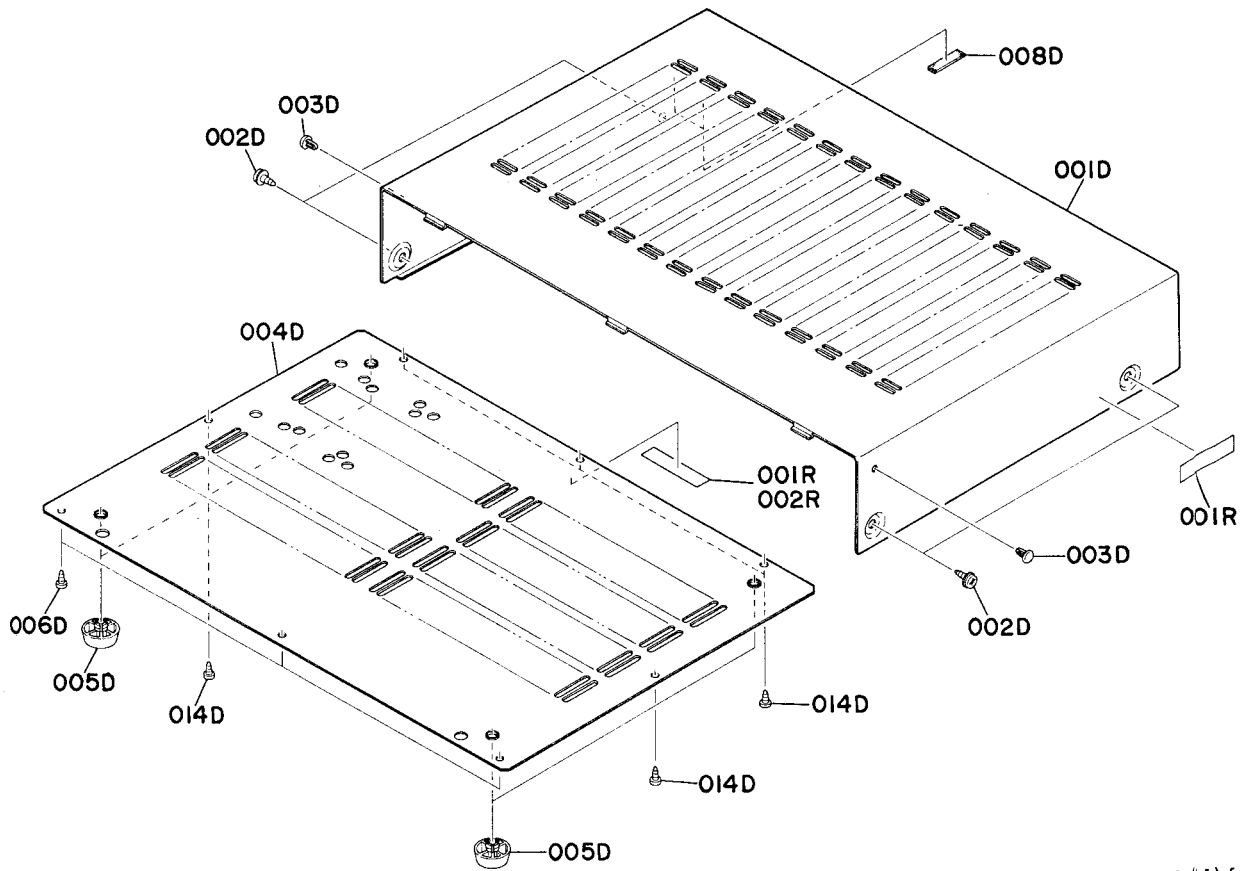

- (U) for U.S.A.
- (N) for Europe
- (A) for Australia

REF. DESIG.	Q'TY			PART NO.	DESCRIPTION
	U	N	A		
001D	1	1	1	234H257010	Lid, Top Cover
002D	4	4	4	51260408U0	B.T. Screw B4 x 8
003D	2	2	2	2991259010	Bushing
004D	1	1	1	208H257020	Lid, Bottom Cover
005D	4	4	4	403H057010	Leg
006D	3	3	3	51280308B0	B.H. Tapped Screw B3 x 8
008D	2	2	2	2964056010	Buffer
014D	5	5	5	51280308B0	B.H. Tapped Screw B3 x 8

REF. DESIG.	Q'TY			PART NO.	DESCRIPTION
	U	N	A		
001R	2			117H861020	Label
001R		1	1	2932861010	Label
002R		1	1	2578861010	Label

• [C03-99] Rear Panel

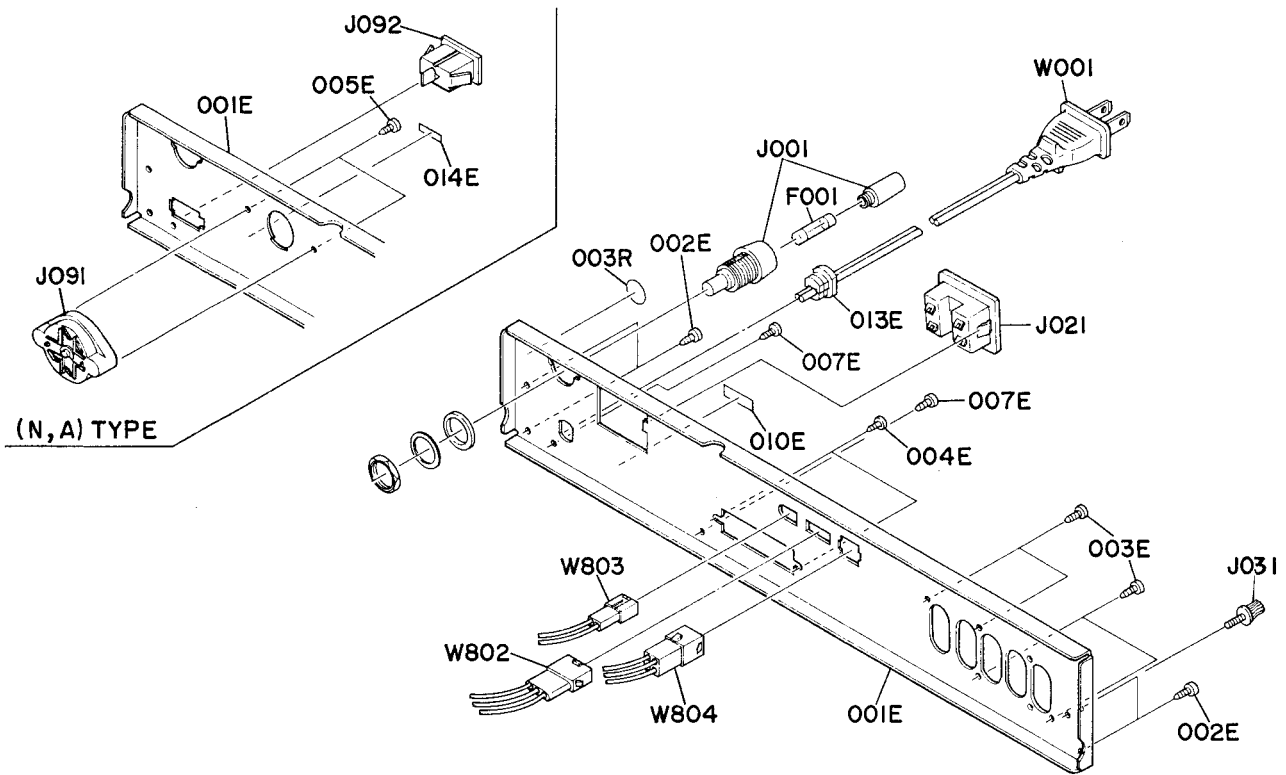

- (U) for U.S.A.
- (N) for Europe
- (A) for Australia

REF. DESIG.	Q'TY			PART NO.	DESCRIPTION
	U	N	A		
001E	1			230H160210	Bracket, Rear Panel
001E		1	1	230H160230	Bracket, Rear Panel
002E	4	4	4	51280308B0	B.H. Tapped Screw B3 x 8
003E	4	4	4	51280308B0	B.H. Tapped Screw B3 x 8
004E	2	2	2	51280308B0	B.H. Tapped Screw B3 x 8
005E	2	2	2	51280308B0	B.H. Tapped Screw B3 x 8
007E	2	2	2	51280308B0	B.H. Tapped Screw B3 x 8
010E	1	1	1	2112265010	Indicator
013E	1			1455259090	Bushing
014E		1	1	4581861010	Label
003R	1			9511101070	Label

REF. DESIG.	Q'TY			PART NO.	DESCRIPTION
	U	N	A		
F001	1			FS10200500	Fuse, 2A 250V
F001		1	1	FS10080800	Fuse, T800mA 250V
J001	1			YJ08000340	Jack, Fuse Holder
J001		1	1	YJ08000290	Jack, Fuse Holder
J021	1			YJ04001020	Jack, AC Outlet
J031	1	1	1	YL03010250	Terminal, Ground
J091	1	1	1	BY05030040	Voltage Selector
J092	1	1	1	YP04000580	Plug, Inlet
W001	1			YC01800260	A.C. Power Cord
W001		1		ZC01805010	A.C. Power Cord
W001			1	ZC02006020	A.C. Power Cord
W802	1	1	1	YB00180100	Connective Cord (3P)
W803	1	1	1	YB00190020	Connective Cord (2P)
W804	1	1	1	YB00180110	Connective Cord (4P)
R001	1			RC10225920	Resistor 2.2MΩ 1/4W
030G	1			62040029W0	Lug

- (U) for U.S.A.
- (N) for Europe
- (A) for Australia

REF. DESIG.	Q'TY			PART NO.	DESCRIPTION
	U	N	A		
001F	1	1	1	208H126010	Stay, Right
002F	1	1	1	208H126020	Stay, Left
003F	4	4	4	51300308B0	P.H. Tapped Screw P3 x 8
007F	2	2	2	51260308B0	B.T. Screw B3 x 8
012F	1	1	1	234H004010	Table
013F	2	2	2	51280308B0	B.H. Tapped Screw B3 x 8
014F	2	2	2	51260308B0	B.T. Screw B3 x 8
015F	4	4	4	51570406B0	P. TaPT. Screw P4 x 6
016F	2	2	2	2147056010	Buffer
017F	2	2	2	208H118020	Spacer
018F	4	4	4	54010600A0	Flat Washer, S.
001G	1	1	1	234H160010	Bracket, Front Chassis
002G	2	2	2	51100306A9	B.H.M. Screw B3 x 6
003G	2	2	2	51100306A9	B.H.M. Screw B3 x 6
007G	1	1	1	5911429960	Washer
001L	1	1	1	230H267010	Heatsink
002L	5	5	5	51280312B0	B.H. Tapped Screw B3 x 12
003L	4	4	4	51280308B0	B.H. Tapped Screw B3 x 8
005L	1	1	1	62030039W0	Lug
006L	1	1	1	51280308B0	B.H. Tapped Screw B3 x 8
012B	3	3	3	226H154140	Knob, Push Switch
020B	1	1	1	226H154130	Knob, Power Switch

REF. DESIG.	Q'TY			PART NO.	DESCRIPTION
	U	N	A		
G001	1			DK18103530	Ceramic Cap. 0.01μF 250V
G001		1		DK18103840	Ceramic Cap. 0.01μF 250V
G001			1	DK18103850	Ceramic Cap. 0.01μF 250V
L001	1			TS17623020	Power Transformer
L001		1	1	TS17623010	Power Transformer
S001	1			SP01010420	Push Switch, Power
S001		1	1	SP01010390	Push Switch, Power
S012	1	1	1	SR00030070	Rotary Switch
SS01	1	1	1	SP02030180	Push Switch
SS02	1	1	1	SS04040040	Slide Switch
Q729	1	1	1	HT325782B0	Transistor 2SC2578(0 or Y)
Q730	1	1	1	HT325782B0	Transistor 2SC2578(0 or Y)
Q731	1	1	1	HT111032B0	Transistor 2SA1103(0 or Y)
Q732	1	1	1	HT111032B0	Transistor 2SA1103(0 or Y)
Q807	1	1	1	HT412652A0	Transistor 2SD1265(0 or P)
WE01	1	1	1	YU02180260	Jumper Lead (2P)
W701	1	1	1	YU03220240	Jumper Lead (3P)
W702	1	1	1	YU03240260	Jumper Lead (3P)
W703	1	1	1	YU03300240	Jumper Lead (3P)
W704	1	1	1	YU02400240	Jumper Lead (2P)
W706	1	1	1	YU02120260	Jumper Lead (2P)
W801	1	1	1	YU03440240	Jumper Lead (3P)

• [H01-99] Packing Materials

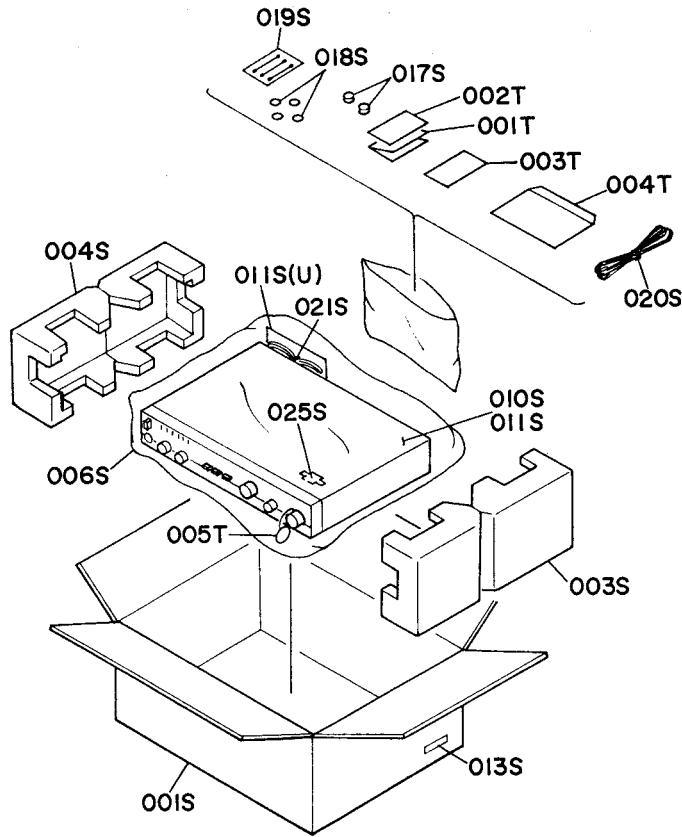

- (U) for U.S.A.
- (N) for Europe
- (A) for Australia

REF. DESIG.	Q'TY			PART NO.	DESCRIPTION
	U	N	A		
001S	1	1	1	230H801010	Packing Case
003S	1	1	1	230H809010	Cushion, (R)
004S	1	1	1	230H809020	Cushion, (L)
006S	1	1	1	9090909030	Polyethylene Sheet
010S	1			2918107350	Sheet
011S	1			2918107390	Sheet
011S		1	1	2918107350	Sheet
013S	3			5926019010	Serial No. Card
013S		2		5926019060	Serial No. Card
013S			3	5926019030	Serial No. Card
017S	2	2	2	226H057010	Leg
018S	4	4	4	413H060010	Clinger
019S	1	1	1	4136071010	Cleaner
020S	1	1	1	ZA02000070	EXT. Antenna
021S	1	1	1	402P005040	Clamper, Cord
025S		1		2731821010	Silicagel

REF. DESIG.	Q'TY			PART NO.	DESCRIPTION
	U	N	A		
001T	1			230H851210	Instruction
001T		1	1	230H851310	Instruction
002T	1			230H851220	Instruction, Spec
002T		1	1	230H851320	Instruction, Spec
003T	1			103H854010	Guarantee Card
003T			1	9631000090	Guarantee Card
004T	1			2225813010	Envelope
005T	1			9560000100	Hang Tag

12. ELECTRICAL PARTS LIST

- (U) for U.S.A.
- (N) for Europe
- (A) for Australia

REF. DESIG.	Q'TY			PART NO.	DESCRIPTION
	U	N	A		
P700	1	1	1	YK207H1610	P700-MAIN/PHONO CIRCUIT BOARD P.W. Board, Main/Phono
	1			ZZ230H1610	P.W. Board Assembly
		1		ZZ230H8610	P.W. Board Assembly
			1	ZZ230H7610	P.W. Board Assembly
P700-CAPACITORS					
C401	1	1	1	EA33055030	Elect 3.3μF 50V
C402	1	1	1	EA33055030	Elect 3.3μF 50V
C403	1	1	1	DK16221300	Ceramic 220pF ±10%
C404	1	1	1	DK16221300	Ceramic 220pF ±10%
C405	1	1	1	DF16332300	Film 3300pF ±10%
C406	1	1	1	DF16332300	Film 3300pF ±10%
C407	1	1	1	DF16123300	Film 0.012μF ±10%
C408	1	1	1	DF16123300	Film 0.012μF ±10%
C409	1	1	1	EA33505030	Elect 3.3μF 50V
C410	1	1	1	EA33505030	Elect 3.3μF 50V
C411	1	1	1	EA10701630	Elect 100μF 16V
C412	1	1	1	EA10701630	Elect 100μF 16V
C415	1	1	1	DK17103300	Ceramic 0.01μF ±20%
C416	1	1	1	DK17103300	Ceramic 0.01μF ±20%
C417	1	1	1	DK17103300	Ceramic 0.01μF ±20%
C418	1	1	1	DK17103300	Ceramic 0.01μF ±20%
C419	1	1	1	DK17103300	Ceramic 0.01μF ±20%
C701	1	1	1	EA33505030	Elect 3.3μF 50V
C702	1	1	1	EA33505030	Elect 3.3μF 50V
C703	1	1	1	DK16101300	Ceramic 100pF ±10%
C704	1	1	1	DK16101300	Ceramic 100pF ±10%
C705	1	1	1	EA10701030	Elect 100μF 10V
C706	1	1	1	EA10701030	Elect 100μF 10V
C707	1	1	1	EA33505030	Elect 3.3μF 50V
C708	1	1	1	EA33505030	Elect 3.3μF 50V
C709	1	1	1	EA22601630	Elect 22μF 16V
C710	1	1	1	EA22601630	Elect 22μF 16V
C711	1	1	1	DD15560370	Ceramic 56pF ±5%
C712	1	1	1	DD15560370	Ceramic 56pF ±5%
C713	1	1	1	EA10605030	Elect 10μF 50V
C714	1	1	1	EA10605030	Elect 10μF 50V
C715	1	1	1	DF17103300	Film 0.01μF ±20%
C716	1	1	1	DF17103300	Film 0.01μF ±20%
C717	1	1	1	DF17332350	Film 3300pF ±20%
C718	1	1	1	DF17332350	Film 3300pF ±20%
C719	1	1	1	DF17332350	Film 3300pF ±20%
C720	1	1	1	DF17332350	Film 3300pF ±20%
C721	1	1	1	DK16101550	Ceramic 100pF ±10%
C722	1	1	1	DK16101550	Ceramic 100pF ±10%
C725	1	1	1	DF16473540	Film 0.047μF ±10%
C726	1	1	1	DF16473540	Film 0.047μF ±10%
C725	1	1	1	DF16333540	Film 0.033μF ±10%
C726	1	1	1	DF16333540	Film 0.033μF ±10%
C727	1	1	1	DD16331370	Ceramic 330pF ±5%
C728	1	1	1	DD16331370	Ceramic 330pF ±5%
C729	1	1	1	DK16181300	Ceramic 180pF ±10%
C730	1	1	1	DK16181300	Ceramic 180pF ±10%
C733	1	1	1	DK16151550	Ceramic 150pF ±10%
C734	1	1	1	DK16151550	Ceramic 150pF ±10%
C735	1	1	1	DK16121300	Ceramic 120pF ±10%
C736	1	1	1	DK16121300	Ceramic 120pF ±10%
C737	1	1	1	DK16121300	Ceramic 120pF ±10%
C738	1	1	1	DK16121300	Ceramic 120pF ±10%
C803	1	1	1	EB68804520	Elect 6800μF 45V
C804	1	1	1	EB68804520	Elect 6800μF 45V
C805	1	1	1	EA10705030	Elect 100μF 50V
C807	1	1	1	EA33605030	Elect 33μF 50V

REF. DESIG.	Q'TY			PART NO.	DESCRIPTION
	U	N	A		
C808	1	1	1	EA33605030	Elect 33μF 50V
C811	1	1	1	EA10505030	Elect 1μF 50V
C812	1	1	1	EA10505030	Elect 1μF 50V
C814	1	1	1	DK18103510	Ceramic 0.01μF
C815	1	1	1	DK18103510	Ceramic 0.01μF
CN01	1	1	1	EA33700630	Elect 330μF 6.3V
CN02	1	1	1	EA10505030	Elect 1μF 50V
CN03	1	1	1	EA33605030	Elect 33μF 50V
CS01	1	1	1	DK16271300	Ceramic 270pF ±10%
CS02	1	1	1	DK16271300	Ceramic 270pF ±10%
CS03	1	1	1	DF16683300	Film 0.068μF ±10%
CS04	1	1	1	DF16683300	Film 0.068μF ±10%
CS05	1	1	1	DD15820370	Ceramic 82pF ±5%
CS06	1	1	1	DD15820370	Ceramic 82pF ±5%
CS07	1	1	1	DK17103300	Ceramic 0.01μF ±20%
CS08	1	1	1	DK17103300	Ceramic 0.01μF ±20%
CS09	1	1	1	DK17103300	Ceramic 0.01μF ±20%
P700-RESISTORS (All Resistors are ±5% & 1/4W)					
R401	1	1	1	GD05154140	150KΩ
R402	1	1	1	GD05154140	150KΩ
R403	1	1	1	GD05683140	68KΩ
R404	1	1	1	GD05683140	68KΩ
R405	1	1	1	GD05222140	2.2KΩ
R406	1	1	1	GE05222140	2.2KΩ
R407	1	1	1	GD05471140	470Ω
R408	1	1	1	GD05471140	470Ω
R409	1	1	1	GD05223140	22KΩ
R410	1	1	1	GD05223140	22KΩ
R411	1	1	1	GD05274140	270KΩ
R412	1	1	1	GD05274140	270KΩ
R413	1	1	1	GD05103140	10KΩ
R414	1	1	1	GD05103140	10KΩ
R415	1	1	1	GG05101140	100Ω
R416	1	1	1	GG05101140	100Ω
R417	1	1	1	GD05271140	270Ω
R418	1	1	1	GD05271140	270Ω
R701	1	1	1	GD05471140	470Ω
R702	1	1	1	GD05471140	470Ω
R703	1	1	1	GD05473140	47KΩ
R704	1	1	1	GD05473140	47KΩ
R705	1	1	1	GD05103140	10KΩ
R706	1	1	1	GD05103140	10KΩ
R707	1	1	1	GD05393140	39KΩ
R708	1	1	1	GD05393140	39KΩ
R709	1	1	1	GD05332140	3.3KΩ
R710	1	1	1	GD05332140	3.3KΩ
R711	1	1	1	GD05104140	100KΩ
R712	1	1	1	GD05104140	100KΩ
R713	1	1	1	GD05682140	6.8KΩ
R714	1	1	1	GD05682140	6.8KΩ
R715	1	1	1	GD05682140	6.8KΩ
R716	1	1	1	GD05682140	6.8KΩ
R717	1	1	1	GD05333140	33KΩ
R718	1	1	1	GG05333140	33KΩ
R719	1	1	1	GG05392140	3.9KΩ
R720	1	1	1	GG05392140	3.9KΩ
R721	1	1	1	GD05392140	3.9KΩ
R722	1	1	1	GD05392140	3.9KΩ
R723	1	1	1	GD05222140	2.2KΩ
R724	1	1	1	GD05222140	2.2KΩ
R725	1	1	1	RA02020800	2KΩ(B), Trimming
R726	1	1	1	RA02020800	2KΩ(B), Trimming

- (U) for U.S.A.
- (N) for Europe
- (A) for Australia

REF. DESIG.	Q'TY			PART NO.	DESCRIPTION
	U	N	A		
R727	1	1	1	GD05122140	1.2KΩ
R728	1	1	1	GD05122140	1.2KΩ
R729	1	1	1	GG05152140	1.5KΩ
R730	1	1	1	GG05152140	1.5KΩ
R731	1	1	1	GD05563140	56KΩ
R732	1	1	1	GD05563140	56KΩ
R733	1	1	1	GG05151140	150Ω
R734	1	1	1	GG05151140	150Ω
R735	1			GD05333140	33KΩ
R736	1			GD05333140	33KΩ
R737	1			GD05822140	8.2KΩ
R738	1			GD05822140	8.2KΩ
R739	1			GD05822140	8.2KΩ
R740	1			GD05822140	8.2KΩ
R741	1			GG05471140	470Ω
R742	1			GG05471140	470Ω
R743	1			GG05471140	470Ω
R744	1			GG05471140	470Ω
R745	1	1	1	GG05221120	220Ω ½W
R746	1	1	1	GG05221120	220Ω ½W
R747	1	1	1	GB05272020	2.7KΩ 2W
R748	1	1	1	GB05272020	2.7KΩ 2W
R749	1	1	1	GB05272020	2.7KΩ 2W
R750	1	1	1	GB05272020	2.7KΩ 2W
R751	1			GA05100020	10Ω 2W
R752	1			GA05100020	10Ω 2W
R751	1	1	1	GA05150020	15Ω 2W
R752	1	1	1	GA05150020	15Ω 2W
R753	1	1	1	GG05022120	2.2Ω ½W
R754	1	1	1	GG05022120	2.2Ω ½W
R755	1	1	1	GD05681140	680Ω
R756	1	1	1	GD05681140	680Ω
R757	1	1	1	GD05273140	27KΩ
R758	1	1	1	GD05273140	27KΩ
R759	1	1	1	GD05123140	12KΩ
R760	1	1	1	GD05123140	12KΩ
R761	1	1	1	GG05100140	10Ω
R762	1	1	1	GG05100140	10Ω
R802	1	1	1	GA05222020	2.2KΩ 2W
R803	1	1	1	GD05182140	1.8KΩ
R805	1	1	1	RF05150120	15Ω ½W, Fusible
R805	1			GA05220010	22Ω 1W
R806	1	1	1	RF05820120	82Ω ½W, Fusible
R806	1			GG05471120	470Ω ½W
R807	1	1	1	GD05272140	2.7KΩ
R808	1	1	1	GD05272140	2.7KΩ
R809	1	1	1	GA05820020	82Ω 2W
R810	1	1	1	GA05390010	39Ω 1W
RN01	1	1	1	GD05471140	470Ω
RN02	1	1	1	GD05471140	470Ω
RN03	1	1	1	GD05103140	10KΩ
RN04	1	1	1	GD05474140	470KΩ
RN05	1	1	1	GD05124140	120KΩ
RN06	1	1	1	GD05124140	120KΩ
RN07	1	1	1	GD05104140	100KΩ
RS01	1	1	1	GD05472140	4.7KΩ
RS02	1	1	1	GD05472140	4.7KΩ
RS03	1	1	1	GD05273140	27KΩ
RS04	1	1	1	GD05273140	27KΩ
RS05	1	1	1	GD05822140	8.2KΩ
RS06	1	1	1	GD05822140	8.2KΩ
RS07	1	1	1	RM01040550	100KΩ(B)x2, Variable
RS08	1	1	1	RK02040160	200KΩ(B), Variable

REF. DESIG.	Q'TY			PART NO.	DESCRIPTION
	U	N	A		
P700-SEMICONDUCTORS					
Q401	1	1	1	HC10007090	IC NJM4560
Q701	1	1	1	HT110162A0	Transistor 2SA1016(F or G)
Q702	1	1	1	HT110162A0	Transistor 2SA1016(F or G)
Q703	1	1	1	HT110162A0	Transistor 2SA1016(F or G)
Q704	1	1	1	HT110162A0	Transistor 2SA1016(F or G)
Q705	1	1	1	HD20003210	Diode 1S2471
Q706	1	1	1	HD20003210	Diode 1S2471
Q707	1	1	1	HT317752E0	Transistor 2SC1775A(E or F)
Q708	1	1	1	HT317752E0	Transistor 2SC1775A(E or F)
Q709	1	1	1	HT309452B0	Transistor 2SC945(P or Q)
Q710	1	1	1	HT309452B0	Transistor 2SC945(P or Q)
Q711	1	1	1	HT322402A0	Transistor 2SC2240(GR or BL)
Q712	1	1	1	HT322402A0	Transistor 2SC2240(GR or BL)
Q713	1			HD20001210	Diode 1S2473
Q714	1			HD20001210	Diode 1S2473
Q715	1			HD20001210	Diode 1S2473
Q716	1			HD20001210	Diode 1S2473
Q717	1			HD20001210	Diode 1S2473
Q718	1			HD20001210	Diode 1S2473
Q719	1			HD20001210	Diode 1S2473
Q720	1			HD20001210	Diode 1S2473
Q721	1			HT309452B0	Transistor 2SC945(P or Q)
Q722	1			HT309452B0	Transistor 2SC945(P or Q)
Q723	1			HT107332A0	Transistor 2SA733(P or Q)
Q724	1			HT107332A0	Transistor 2SA733(P or Q)
Q725	1	1	1	HT322742B0	Transistor 2SC2274(E or F)
Q726	1	1	1	HT322742B0	Transistor 2SC2274(E or F)
Q727	1	1	1	HT109842B0	Transistor 2SA984(E or F)
Q728	1	1	1	HT109842B0	Transistor 2SA984(E or F)
Q730	1	1	1	HT325782B0	Transistor 2SC2578(O or Y)
Q731	1	1	1	HT111032B0	Transistor 2SA1103(O or Y)
Q732	1	1	1	HT111032B0	Transistor 2SA1103(O or Y)
Q801	1	1	1	HD20008290	Diode S4VE20
Q805	1	1	1	HD20015030	Diode DS-1350
Q806	1	1	1	HD30014010	Zener HZ16L
Q808	1	1	1	HT107332A0	Transistor 2SA733(P or Q)
Q809	1	1	1	HD30014010	Zener HZ16L
Q810	1	1	1	HD30014010	Zener HZ16L
Q811	1	1	1	HD20015030	Diode DS135D
Q812	1	1	1	HD30042090	Zener BZ052
QN01	1	1	1	HT309452B0	Transistor 2SC945(P or Q)
QN02	1	1	1	HT309452B0	Transistor 2SC945(P or Q)
QN03	1	1	1	HD20015030	Diode DS-135D
QN04	1	1	1	HT309452B0	Transistor 2SC945(P or Q)
QN05	1	1	1	HT107332A0	Transistor 2SA733(P or Q)
QN06	1	1	1	HD30023090	Zener WZ011
QN07	1	1	1	HD20001210	Diode 1S2473
P700-MISCELLANEOUS					
F801	1			FS10350500	Fuse 3.5A 250V
F801	1	1		FS10315800	Fuse 3.15AT
F802	1			FS10350500	Fuse 3.5A 250V
F802	1	1		FS10315800	Fuse 3.15AT
J804		4		YJ08000170	Jack, Fuse Holder
J807		4		YJ08000270	Jack, Fuse Holder
L701	1	1	1	LL23905120	Coil 1μH
L702	1	1	1	LL23905120	Coil 1μH

- (U) for U.S.A.
- (N) for Europe
- (A) for Australia

REF. DESIG.	Q'TY			PART NO.	DESCRIPTION
	U	N	A		
SS01	1	1	1	SP02030180	Push Switch
SS02	1	1	1	SS04040040	Slide Switch
S012	1	1	1	SR00030070	Rotary Switch
JV01	1	1	1	YT02060130	Terminal, RCA Jack 6P
JV02	1	1	1	YT02040260	Terminal, RCA Jack 4P
JV03	1	1	1	YT03040210	Terminal, Speaker
P701	1	1	1	YK207H1620	P701-POWER TR. CIRCUIT BOARD P.W. Board, Power Tr.
	1	1	1	ZZ207H1620	P.W. Board Assembly
Q729	1	1	1	HT325782B0	P701-TRANSISTOR Transistor 2SC2578(O or Y)
P702	1	1	1	YN230H2440	P702-TRANSISTOR CIRCUIT BOARD P.W. Board, Transistor
Q807	1	1	1	HT412652A0	Transistor 2SD1265(O or P)
P001	1	1	1	YK207H1630	P001-POWER SWITCH CIRCUIT BOARD P.W. Board, Power Switch
	1			ZZ207H1630	P.W. Board Assembly
		1	1	ZZ207H8630	P.W. Board Assembly
G001	1			DK18103530	P001-CAPACITORS Ceramic 0.01 μ F 250V
		1		DK18103840	Ceramic 0.01 μ F 250V
			1	DK18103850	Ceramic 0.01 μ F 250V
S001	1			SP01010420	P001-SWITCHES Push Switch, Power
		1	1	SP01010390	Push Switch, Power
PE00	1	1	1	YN230H2410	PE00-TONE CONTROL CIRCUIT BOARD P.W. Board, Tone Control
	1	1	1	ZZ230H2410	P.W. Board Assembly
CE01	1	1	1	EA22601630	PE00-CAPACITORS Elect 22 μ F 16V
	1	1	1	EA22601630	Elect 22 μ F 16V
	1	1	1	EA22701630	Elect 220 μ F 16V
	1	1	1	EA22701630	Elect 220 μ F 16V
	1	1	1	DF16152300	Film 1500pF \pm 10%
	1	1	1	DF16152300	Film 1500pF \pm 10%
	1	1	1	DF16103300	Film 0.01 μ F \pm 10%
	1	1	1	DF16103300	Film 0.01 μ F \pm 10%
	1	1	1	DF16332300	Film 3300pF \pm 10%
	1	1	1	DF16332300	Film 3300pF \pm 10%

REF. DESIG.	Q'TY			PART NO.	DESCRIPTION
	U	N	A		
CE11	1	1	1	DF16473300	Film 0.047 μ F \pm 10%
CE12	1	1	1	DF16473300	Film 0.047 μ F \pm 10%
CE13	1	1	1	EA22601630	Elect 22 μ F 16V
CE14	1	1	1	EA22601630	Elect 22 μ F 16V
CE15	1	1	1	EA22602530	Elect 22 μ F 25V
CE16	1	1	1	EA22602530	Elect 22 μ F 25V
CE17	1	1	1	DK17103300	Ceramic 0.01 μ F \pm 20%
RE01	1	1	1	GD05683140	PE00-RESISTORS (All Resistors are \pm 5% & $\frac{1}{4}$ W) 68K Ω
	1	1	1	GD05683140	68K Ω
	1	1	1	GD05224140	220K Ω
	1	1	1	GD05224140	220K Ω
	1	1	1	GD05222140	2.2K Ω
	1	1	1	GD05222140	2.2K Ω
	1	1	1	GD05221140	220 Ω
	1	1	1	GD05221140	220 Ω
	1	1	1	GD05221140	220 Ω
	1	1	1	GD05221140	220 Ω
RE11	1	1	1	GD05472140	4.7K Ω
	1	1	1	GD05472140	4.7K Ω
	1	1	1	GD05153140	15K Ω
	1	1	1	GD05153140	15K Ω
	1	1	1	RM01040570	100K Ω (C)x2, Variable
	1	1	1	RM01040570	100K Ω (C)x2, Variable
	1	1	1	GD05182140	1.8K Ω
	1	1	1	GD05182140	1.8K Ω
	1	1	1	GD05682140	6.8K Ω
	1	1	1	GD05682140	6.8K Ω
RE21	1	1	1	GD05333140	33K Ω
	1	1	1	GD05333140	33K Ω
	1	1	1	GD05272140	2.7K Ω
	1	1	1	GD05272140	2.7K Ω
	1	1	1	GD05223140	22K Ω
	1	1	1	GD05223140	22K Ω
	1	1	1	GD05561140	560 Ω
	1	1	1	GD05561140	560 Ω
	1	1	1	GD05561140	560 Ω
	1	1	1	GD05561140	560 Ω
QE01	1	1	1	HC10007090	PE00-SEMICONDUCTOR IC NJM-4560

- (U) for U.S.A.
- (N) for Europe
- (A) for Australia

REF. DESIG.	Q'TY			PART NO.	DESCRIPTION
	U	N	A		
PP00	1	1	1	YH234H0210	PP00-FUSE CIRCUIT BOARD P.W. Board, Fuse
	1			ZZ234H0210	P.W. Board Assembly
		1	1	ZZ234H8210	P.W. Board Assembly
CP01	1	1	1	EA47702530	Elect Cap. 470 μ F 25V
QP01	1	1	1	HD20015030	Diode DS135D
FP01	1			FS10100500	Fuse 1A 250V
FP01	1	1	1	FS10050800	Fuse T500mA 250V
JP09	1			YJ08000170	Jack, Fuse Holder
JP09		1	1	YJ08000270	Jack, Fuse Holder
JP10	1			YJ08000170	Jack, Fuse Holder
JP10		1	1	YJ08000270	Jack, Fuse Holder
PW00	1	1	1	YK207H1640	PW00-HEADPHONE CIRCUIT BOARD P.W. Board, Headphone
	1	1	1	ZZ230H1640	P.W. Board Assembly
RW01	1	1	1	GA05331010	Resistor 330 Ω \pm 5% 1W
RW02	1	1	1	GA05331010	Resistor 330 Ω \pm 5% 1W
JW01	1	1	1	YJ01001650	Jack, Headphone
PX01	1	1	1	YK234H1520	PX01-LED LEVEL METER DRIVE CIRCUIT BOARD P.W. Board, LED Level Meter Drive
		1	1	ZZ234H1520	P.W. Board Assembly
CX01	1	1	1	EA10505030	PX01-CAPACITORS Elect 1 μ F 50V
	1	1	1	EA10505030	Elect 1 μ F 50V
	1	1	1	EA10505030	Elect 1 μ F 50V
	1	1	1	EA10505030	Elect 1 μ F 50V
	1	1	1	EA33701630	Elect 330 μ F 16V
RX14	1	1	1	GD05274140	PX01-RESISTORS (All Resistors are \pm 5% & $\frac{1}{4}$ W) 270K Ω
	1	1	1	GD05274140	270K Ω
	1	1	1	RA02030800	20K Ω , Trimming
	1	1	1	RA02030800	20K Ω , Trimming
	1	1	1	GD05183140	18K Ω
	1	1	1	GD05104140	100K Ω
	1	1	1	GD05682140	6.8K Ω

REF. DESIG.	Q'TY			PART NO.	DESCRIPTION
	U	N	A		
QX01	1	1	1	HC10040030	PX01-SEMICONDUCTORS IC LB1416
	1	1	1	HD20011050	Diode 1S1555
	1	1	1	HD30076090	Zener WZ038
JX01	1	1	1	YJ07000760	PX01-MISCELLANEOUS Jack, 2P
	1	1	1	YJ07000760	Jack, 2P
PX02	1	1	1	YN230H2430	PX02-LED LEVEL METER CIRCUIT BOARD P.W. Board, LED Level Meter
	1	1	1	ZZ230H2430	P.W. Board Assembly
RX08	1	1	1	GD05471140	PX02-RESISTORS (All Resistors are \pm 5% & $\frac{1}{4}$ W) 470 Ω
	1	1	1	GD05181140	180 Ω
	1	1	1	GD05181140	180 Ω
	1	1	1	GD05181140	180 Ω
	1	1	1	GD05181140	180 Ω
	1	1	1	GD05181140	180 Ω
	1	1	1	GD05181140	180 Ω
QX04	1	1	1	HI10031020	PX02-SEMICONDUCTORS L.E.D. LN-324GP
	1	1	1	HI10030020	L.E.D. LN-224RP
	1	1	1	HI10030020	L.E.D. LN-224RP
	1	1	1	HI10030020	L.E.D. LN-224RP
	1	1	1	HI10030020	L.E.D. LN-224RP
	1	1	1	HI10030020	L.E.D. LN-224RP
	1	1	1	HI10030020	L.E.D. LN-224RP

NOTE ON SAFETY:

Symbol Δ Fire or electrical shock hazard. Only original parts should be used to replace any part marked with symbol Δ . Any other component substitution (other than original type), may increase risk of fire or electrical shock hazard.

(W01-99)	Assembly and Wiring
(T01-99)	Adjustment
(X01-00)	Correction

13. TECHNICAL SPECIFICATIONS

POWER OUTPUT PER CHANNEL

DIN 8 OHMS 1 kHz	25 W
RMS 8 OHMS 1 kHz	25 W
TOTAL HARMONIC DISTORTION AT RMS 8 OHMS	0.05 %

Frequency Response

MM (RIAA)	±2.0 dB
Aux (±1 dB)	(U version) 20 Hz ~ 30 kHz (N version) 20 Hz ~ 25 kHz

Signal to Noise Ratio (IHF-A Network)

Phono (MM)	.77 dB
Aux	.98 dB
Dimensions (W x H x D)	416 x 81 x 302 mm
Weight	5.2 kg

Specifications and appearance are subject to change for modification without notice.

14. SCHEMATIC DIAGRAM

MODEL PM225

Q709, Q710, Q721, Q722 QN01, QN02, QN04 25C945 (P or Q) HT30945280	QN03, Q805, Q811 DS135D HD20015030	QN05, Q808 25A733 (P or Q) HT107332A0	QN06 WZ071 HD30023090	QN07, Q713 ~ Q720 IS2473 HD20001210	Q701 ~ Q704 25A1016 HT110162A0	Q705, Q706 IS2471 HD20003210	Q707, Q708 25C1400 (E)	Q711, Q712 25C2240 (GR or BL) HT322402A0	Q723, Q724 25C733 HT107332A0	Q725, Q726 25D667 HT406672F0	Q727, Q728 25B647 HT206472F0	Q729, Q730 25C2578 (O, Y) HT325782B0	Q731, Q732 25A1103 (O, Y) HT111032B0
---	--	---	-----------------------------	---	--------------------------------------	------------------------------------	---------------------------	--	------------------------------------	------------------------------------	------------------------------------	--	--

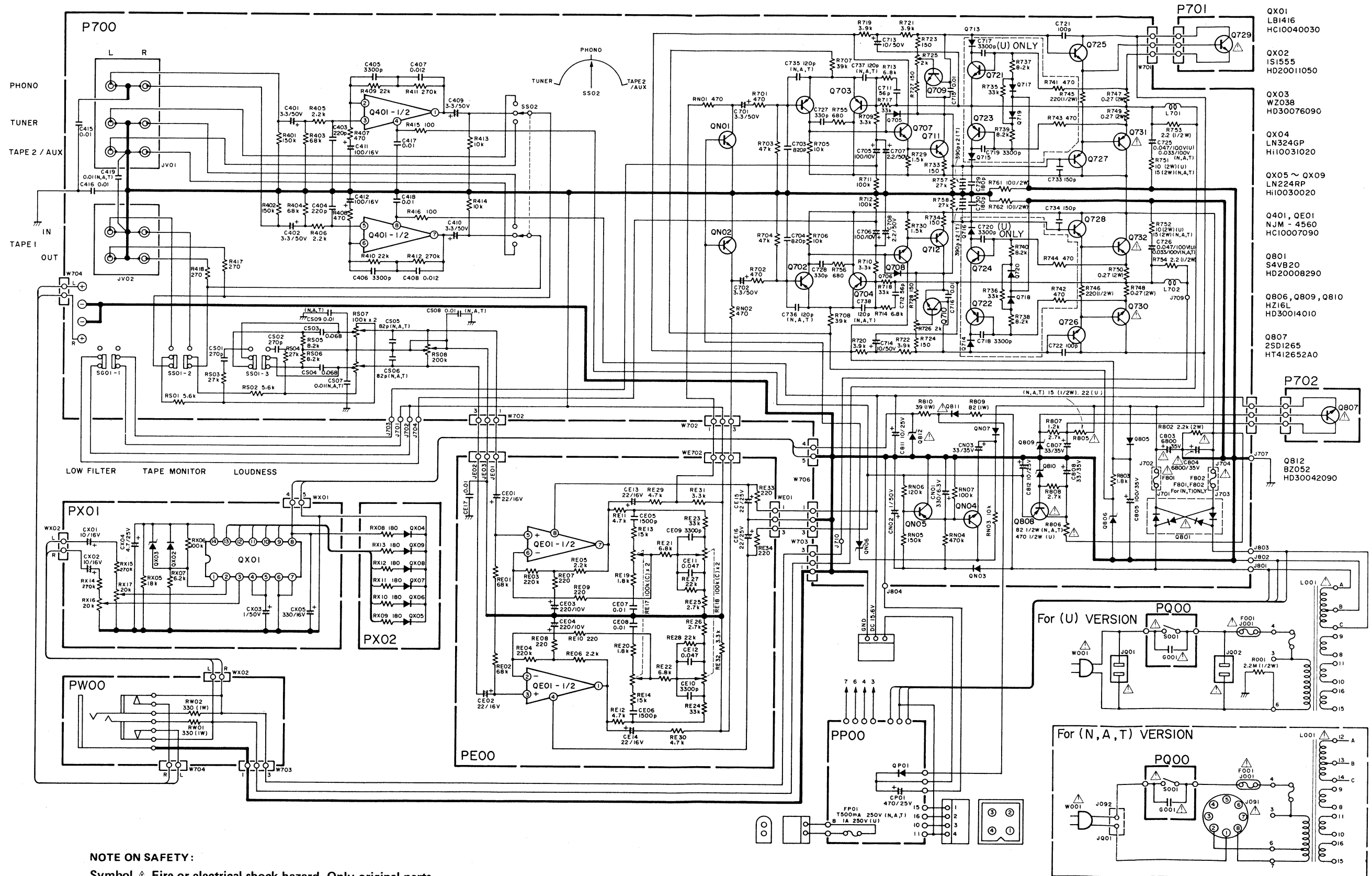

- QX01 LBI416
HC10040030
- QX02 IS1555
HD20011050
- QX03 WZ038
HD30076090
- QX04 LN324GP
HI10031020
- QX05 ~ QX09
LN224RP
HI10030020
- Q401, QE01
NJM - 4560
HC10007090
- Q801
S4VB20
HD20008290
- Q806, Q809, Q810
HZ16L
HD30014010
- Q807
25D1265
HT412652A0
- Q812
BZ052
HD30042090
- Q401, QE01
TOP VIEW
NJM - 4560
- Q401, QE01
TOP VIEW
LBI416
- QX01

NOTE ON SAFETY:
 Symbol Fire or electrical shock hazard. Only original parts should be used to replace any part marked with symbol . Any other component substitution (other than original type), may increase risk of fire or electrical shock hazard.

Components and wiring are subject to change for modification without notice.



marantz®