

395

SERVICE
MANUAL

PM340/PM240

marantz®

model PM340/PM240

Stereo Pre Main Amplifier

MARANTZ DESIGN AND SERVICE

Using superior design and selected high grade components, MARANTZ company has created the ultimate in stereo sound. Only **original MARANTZ parts** can insure that your MARANTZ product will continue to perform to the specifications for which it is famous.

Parts for your MARANTZ equipment are generally available to our National Marantz Subsidiary or Agent.

ORDERING PARTS:

Parts can be ordered either by mail or by telex. In both cases, MARANTZ part number has to be specified. If you order by mail, fulfil MARANTZ order forms.

MARANTZ S.A.
EUROPEAN PARTS DEPARTMENT
2, Avenue Léopold III
B-7120 PERONNES-lez-BINCHE
BELGIUM
TWX: 57589 SEPLT B

The following information must be supplied to eliminate delays in processing your order:

1. Complete address
2. Complete part numbers and quantities required
3. Description of parts
4. Model number for which part is required
5. Way of shipment
6. Signature: any order form or telex must be signed otherwise such part order will be considered as null and void.

PARTS ORDERING:

Parts may be ordered from the following addresses:

EUROPE

MARANTZ S.A.

European Parts Department
2, Avenue Léopold III
B-7120 Péronnes-lez-Binche
Belgium
Telex: 57589

MARANTZ DENMARK

Bregnerødvej 132b
3460 Birkerød
Denmark
Telex: 39137

MARANTZ BELGIUM

45 Rue Auguste Van Zande
1080 Brussels
Belgium

MARANTZ NEDERLAND B.V.

Wagenmackersweg 3
3449 H.V. Woerden
Netherlands

MARANTZ S.A.

326 Avenue Louise Bte 32
1050 Bruxelles
Belgium
Telex: 26602

MARANTZ FRANCE

4 Rue Bernard Palissy
92600 Asnières
France
Telex: 611651

MARANTZ SVENSKA A.B.

Svartviksvägen 56
Träneberg Bromma
Sweden
Telex: 13449

MARANTZ ITALIANA S.p.A.

Via Monte Napoleone, 10
20121 Milano
Italy

MARANTZ GERMANY G.M.B.H.

Max-Planckstrasse 22
6072 Dreieich 1
Germany
Telex: 4185316

MARANTZ AUDIO U.K. LTD.

Unit 15/16
Saxon Way Industrial Estate
Moor Lane
Harmondsworth UB7 0LW
Great Britain
Telex: 935196

MARANTZ AUSTRIA Ge.M.B.H.

25 Franz Lisztgasse
2380 Perchtoldsdorf
Austria
Telex: 113583

AUSTRALIA

MARANTZ AUSTRALIA PTY., LTD.

19 Chard Road
Brookvale, NSW 2100
Australia
Telex: 24121

All of the above locations are fully equipped to take care of your total service needs. Because various countries have differing configuration requirements, it is necessary that you contact the service facility in your particular country. In the event that there is no service location listed for your country, please, contact the nearest facility for the necessary assistance.

In case of difficulties, do not hesitate to contact the Technical Department at abovementioned address.

marantz®

TABLE OF CONTENTS

SECTION	PAGE
INTRODUCTION	1
1. P.W. BOARDS	1
2. TEST EQUIPMENT REQUIRED FOR SERVICING	2
3. ADJUSTMENT PROCEDURES	2
4. FUNCTIONAL EXPLANATION	2
5. VOLTAGE CONVERSION	3
6. BLOCK DIAGRAM	4
7. DIAGRAM AND COMPONENT LOCATIONS	5
7.1 Speaker Switch Assembly (PN01) Schematic Diagram and Component Locations	5
7.2 Power Switch Assembly (PP01) Schematic Diagram and Component Locations	5
7.3 Headphone Jack Assembly (PW01) Schematic Diagram and Component Locations	5
7.4 Speaker Lamp Assembly (PX01) Schematic Diagram and Component Locations	5
7.5 Main Amp. Assembly (P701) Schematic Diagram and Component Locations	6
7.6 Volume Assembly (PE01) Schematic Diagram and Component Locations	6
8. EXPLODED VIEW AND PARTS LIST	10
9. ELECTRICAL PARTS LIST	12
10. TECHNICAL SPECIFICATIONS (PM340)	16
(PM240)	17
11. SCHEMATIC DIAGRAM (PM340)	18
(PM240)	19

MODEL PM340/PM240 STEREO PRE MAIN AMPLIFIER

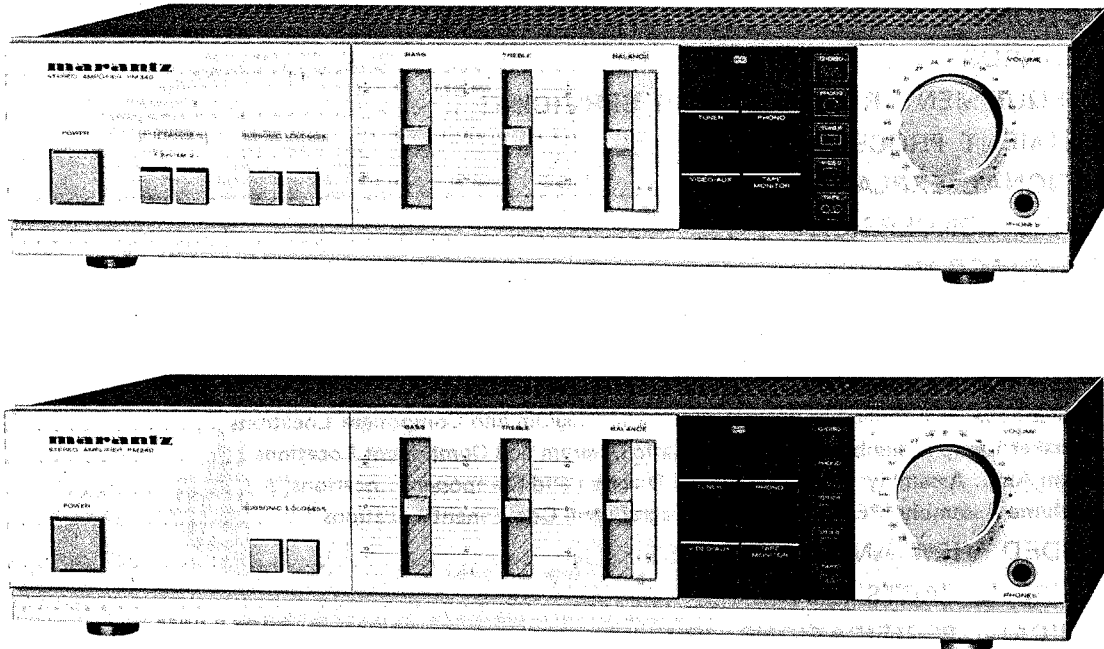

INTRODUCTION

This service manual was prepared for use by Authorized Warranty Stations and contains service information for the Marantz Model PM340/PM240 Stereo Pre Main Amplifier.

Servicing information and voltage data included in this manual are intended for use by knowledgeable and experienced personnel only. All instructions should be read carefully. No attempt should be made to proceed without a good understanding of circuitry operation.

The parts list furnishes complete ordering information. Most replacement parts should be ordered from the Marantz Company. However, a simple description is included for parts which can be obtained locally.

1. P.W. BOARDS

As can be seen from the circuit diagram the chassis of Model PM340/PM240 consists of the following units. Each unit mounted on a printed circuit board is described within the square enclosed by a bold dotted line on the circuit diagram.

1. Main Amp. mounted on P.W. Board P701
2. Volume mounted on P.W. Board PE01
3. Power Switch mounted on P.W. Board PP01
4. Headphone Jack mounted on P.W. Board PW01
5. Speaker Switch mounted on P.W. Board PN01
(PM340)
6. Speaker Lamp mounted on P.W. Board PX01
(PM340)

2. TEST EQUIPMENT REQUIRED FOR SERVICING

This table lists the test equipment required for servicing the Model PM340/PM240 Stereo Pre Main Amplifier.

Item	Use
Distortion Analyzer	Distortion measurements
Audio Oscillator	Sinewave and squarewave signal source
AC VTVM	Voltage measurements (AC)
Oscilloscope	Waveform analysis and trouble shooting and ASO alignment
Circuit Tester	Trouble shooting
DC VTVM	Voltage measurements (DC)
AC Wattmeter	Monitors primary power to amplifier
Line Voltmeter	Monitors potential of primary power to amplifier
Variable Autotransformer (0 ~ 140V AC, 10A)	Adjust level of primary power to amplifier
Shorting Plug	Shorts amplifier input to eliminate noise pickup

3. ADJUSTMENT PROCEDURES

IDLING ADJUSTMENT

1. Set the input and the output of the unit to OPEN.
2. Connect a digital voltmeter between TP-1 and TP-2 of channel L, and between TP-3 and TP-4 of channel R.
3. Turn on the power switch, wait for 10 seconds, and then adjust R735 of channel L and R736 of channel R so that the digital voltmeter registers 12 mV (22 mA).

4. FUNCTIONAL EXPLANATION

1. FUNCTION SWITCH

This unit can store more than one week's schedule in its memory, thanks to the four source-one monitor high voltage resistant analogue function switch IC and the capacitor backup for the memory. When the charge of the memory backup reaches zero, the tuner will be initialized. Additionally, the mute signal for the popping sound caused when the function is switched is output from DS02 so that the input of the main amplifier will be muted.

2. TONE AMPLIFIER

The tone amplifier features a simple design that uses a single operational amplifier. The level of 100 Hz and 10 kHz can be controlled over a range of ± 10 dB, and the gain is approximately 20 dB. The output stage is connected to the subsonic filter formed by CE21 and CE22 (0.068 μ F).

3. POWER AMPLIFIER

The power amplifier uses the monolithic IC UPC1270H which includes a driver stage as the voltage amplifier, and discrete power transistors for the final stage.

4. MUTING and LIMITER

QK02 ~ QK04 enable the muting driver to control the voltage of pin 2 of UPC1270H. This drives the muting circuit when the power is turned on or off.

The limiter uses Q709 and Q710 to detect the current of the power transistors, and drives QK05 which operates the muting circuit.

5. SPEAKER OUTPUT MUTING (PM240 Only)

The sound output from the speakers can be cut off by the speaker selector switch (System 1, 2). The sound output from the speakers will also be cut off when the indicator goes out or when a pair of headphones are connected to the headphones jack.

5. VOLTAGE CONVERSION

• EUROPEAN MODEL ONLY

To convert the unit to a different power source voltage, change the position as illustrated in the drawing below.

CAUTION
DISCONNECT POWER SUPPLY CORD FROM AC
OUTLET BEFORE CONVERTING VOLTAGE.

Voltage Conversion Chart

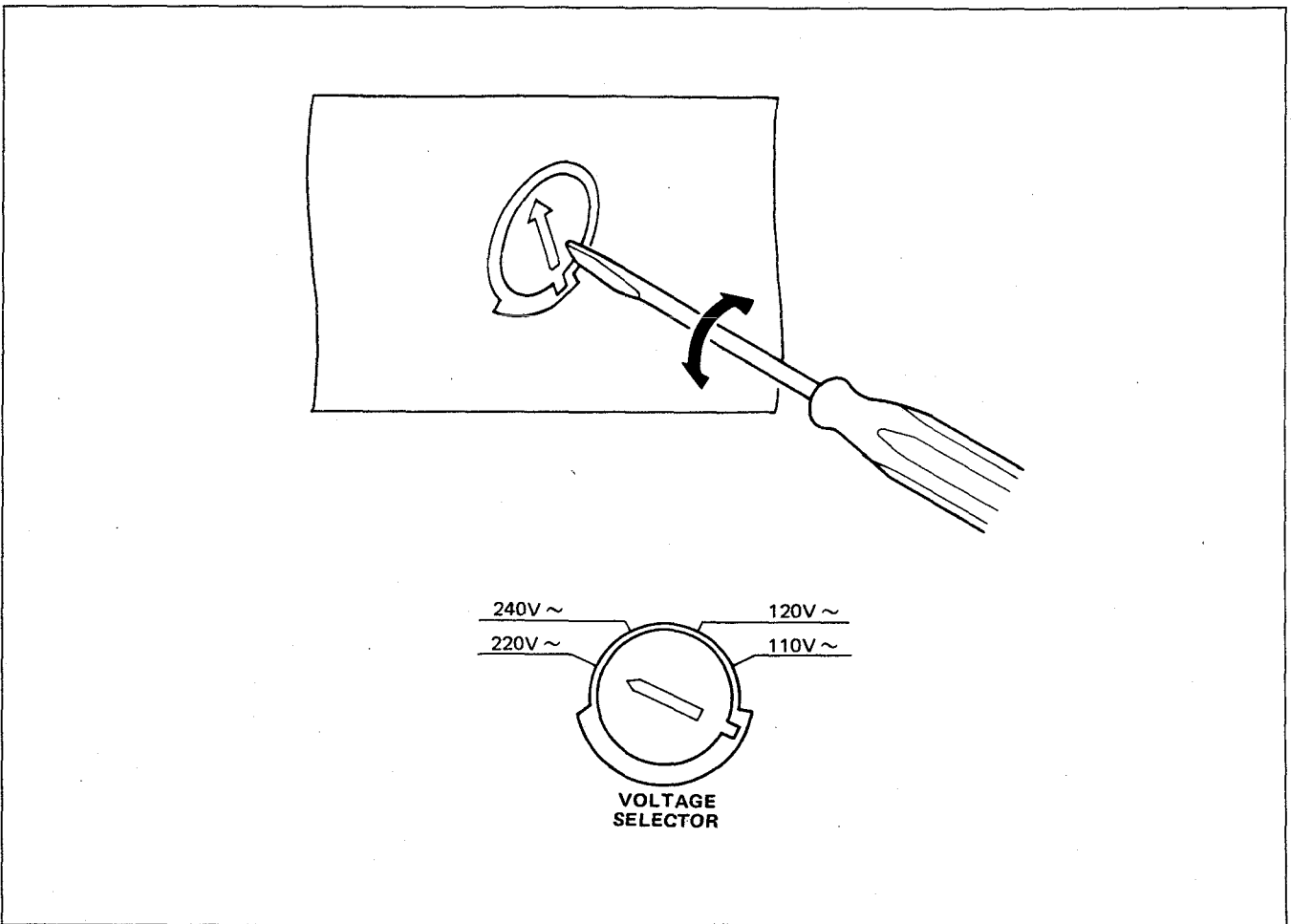

Note on safety: Symbol \triangle Fire or electrical shock hazard. Only original parts should be used to replace any part marked with symbol \triangle . Any other component substitution (other than original type), may increase risk of fire or electrical shock hazard.

6. BLOCK DIAGRAM

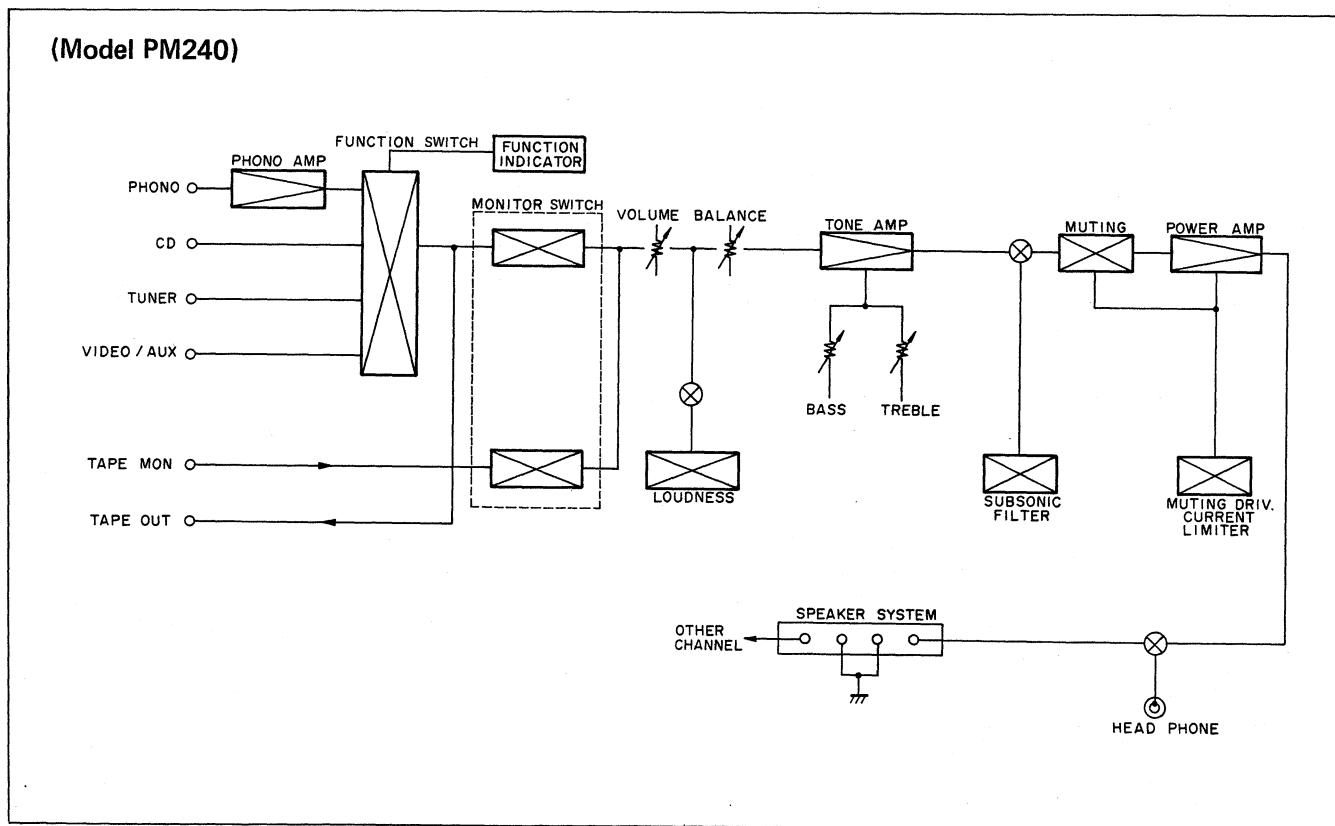
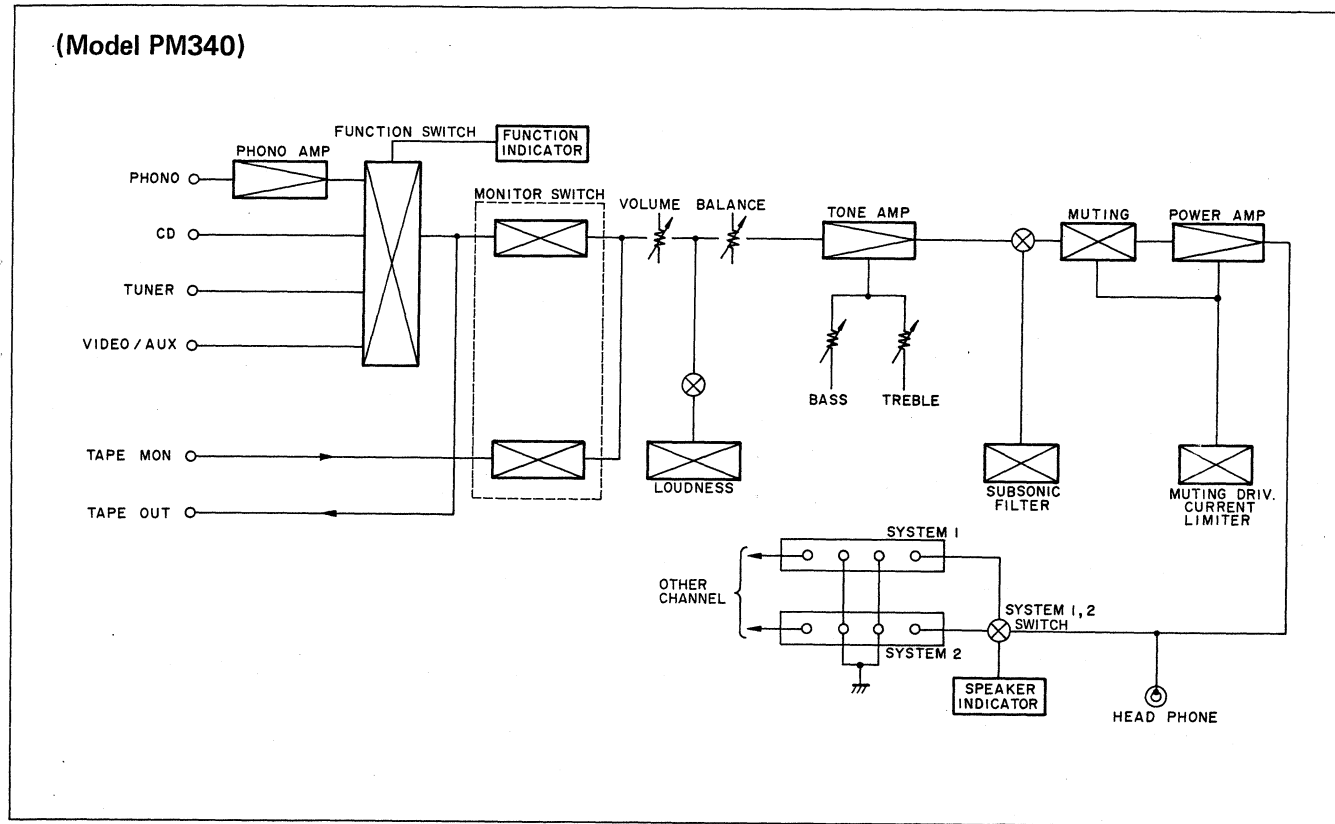

7. DIAGRAM AND COMPONENT LOCATIONS

7.1 Speaker Switch Assembly (PN01)
Schematic Diagram and Component Locations

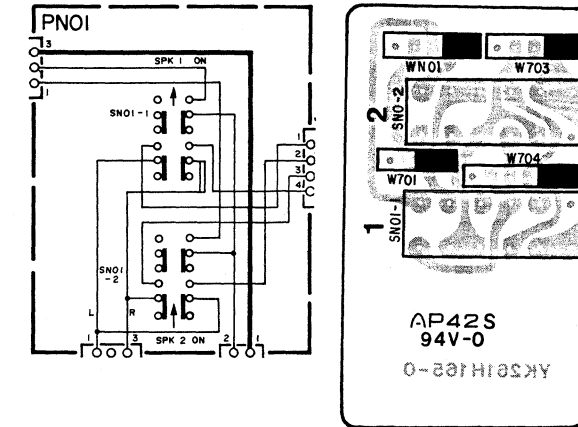

7.2 Power Switch Assembly (PP01)
Schematic Diagram and Component Locations

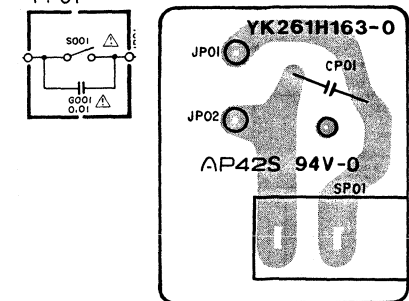

7.3 Headphone Jack Assembly (PW01)
Schematic Diagram and Component Locations

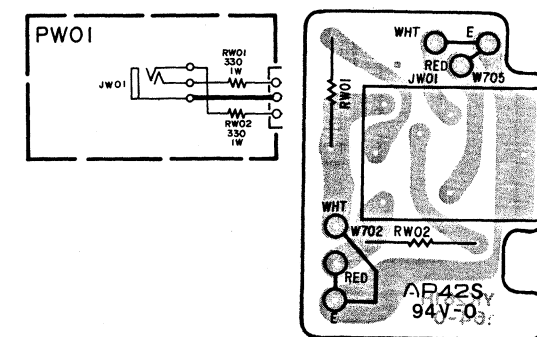

7.4 Speaker Lamp Assembly (PX01)
Schematic Diagram and Component Locations

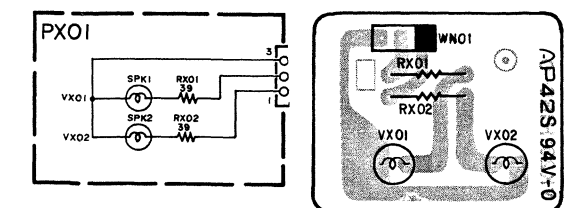

7.5 Main Amp. Assembly (P701)
Schematic Diagram and Component Locations

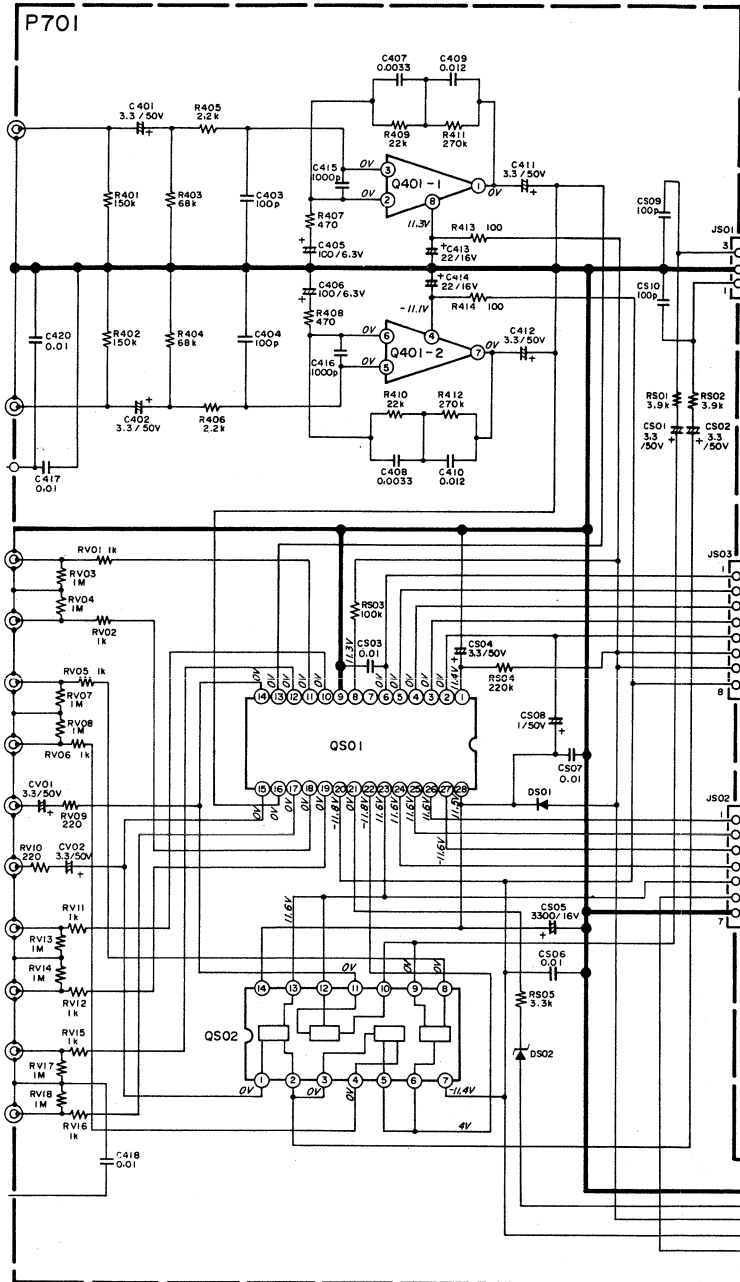

7.6 Volume Assembly (PE01) Schematic Diagram and Component Locations

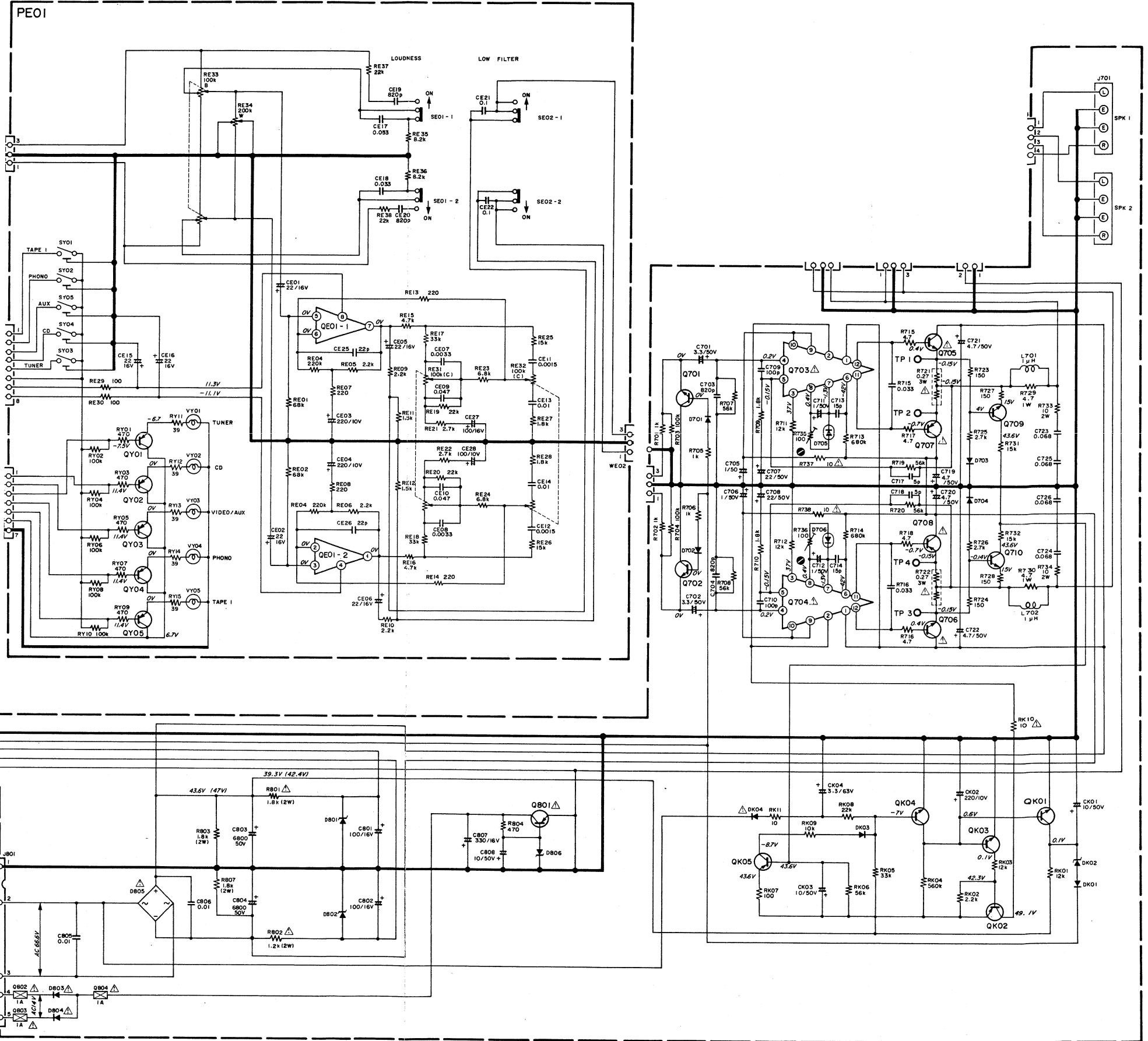

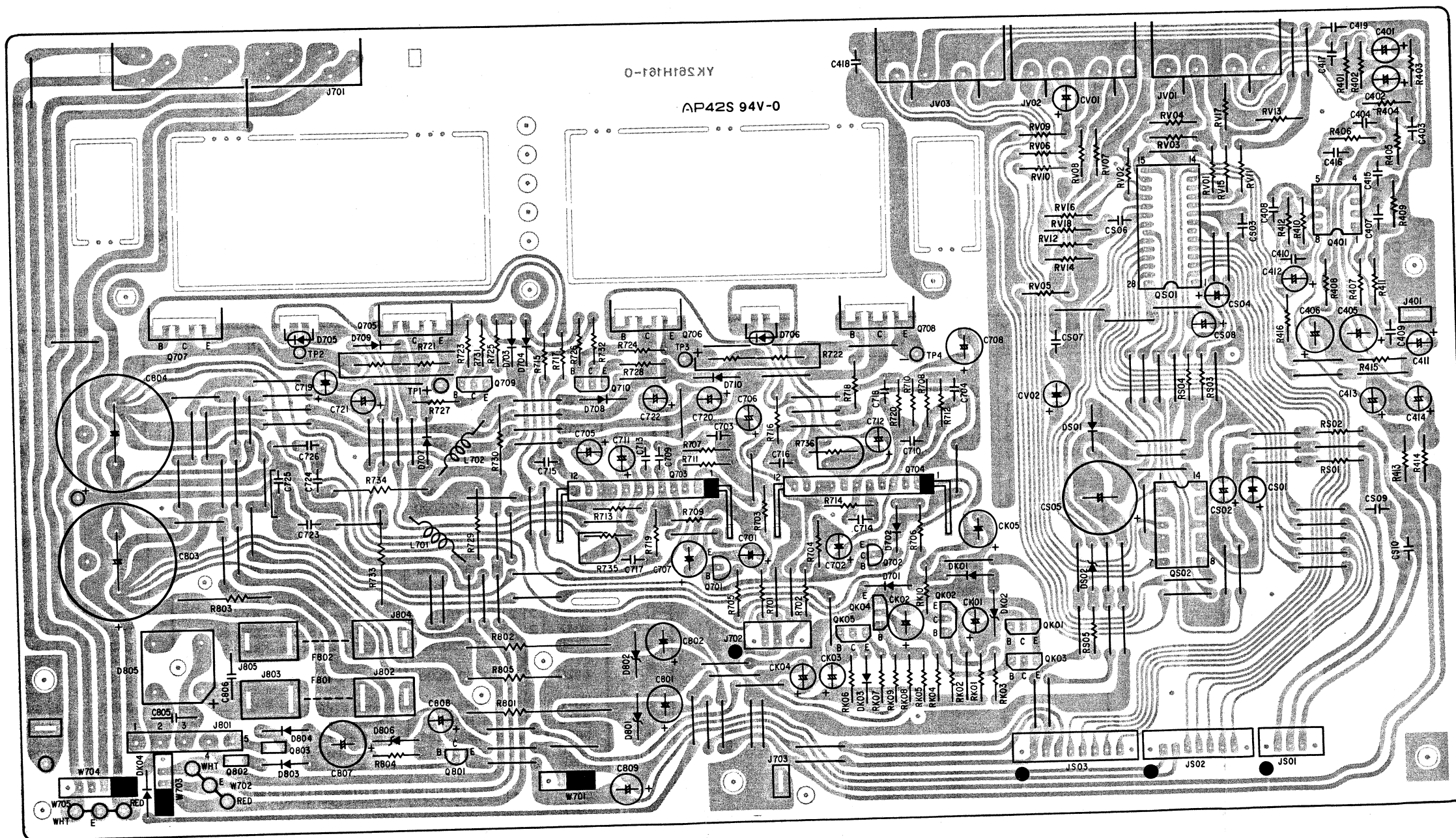
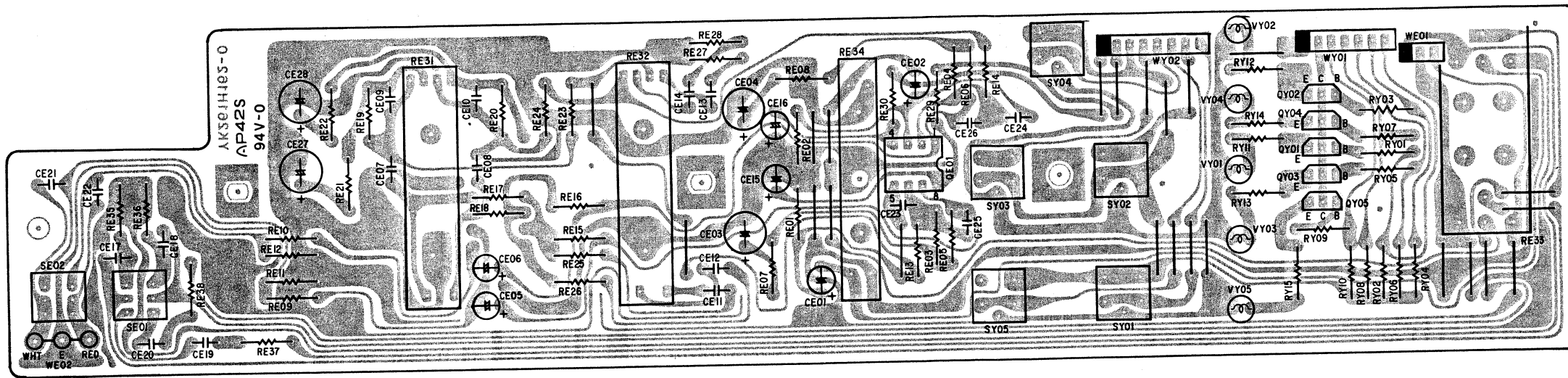

8. EXPLODED VIEW AND PARTS LIST

● [P01-99] Front Panel/Chassis and General Parts

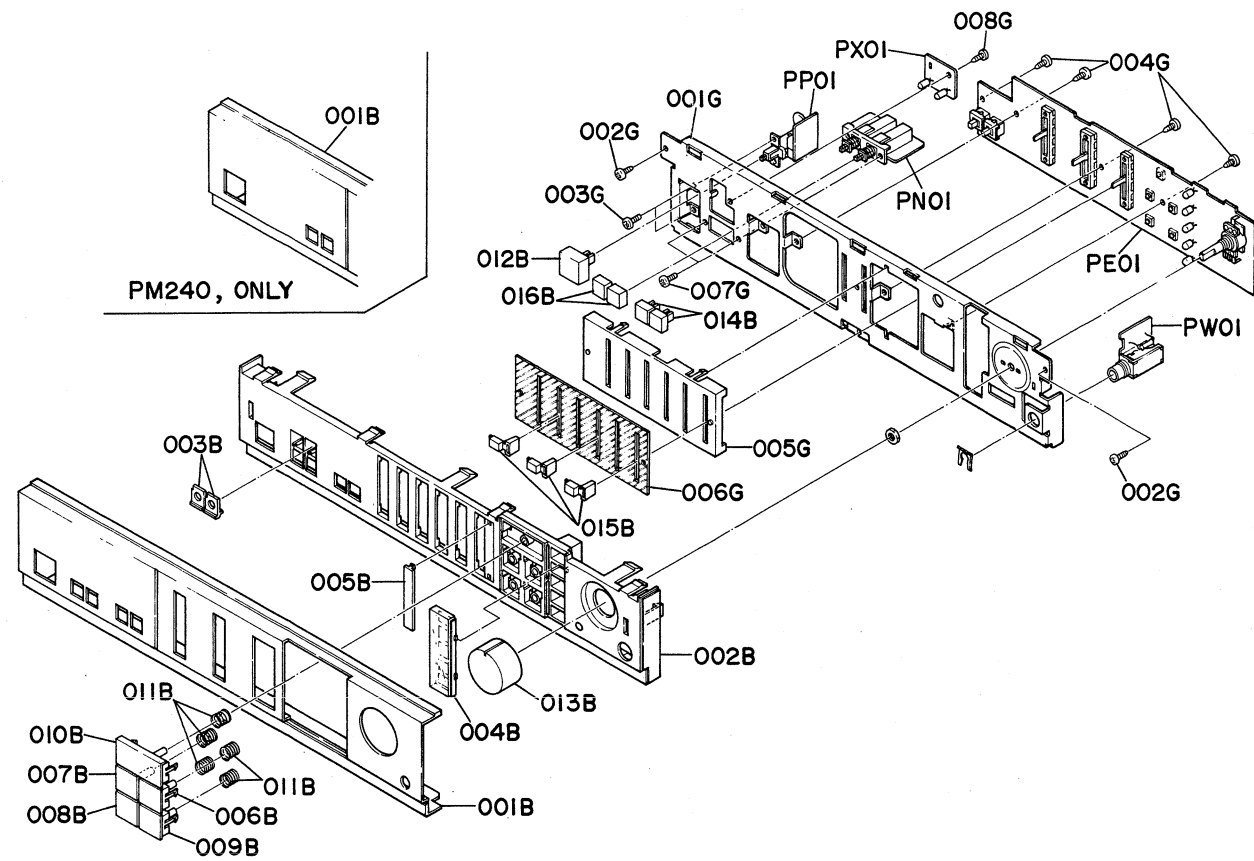

● [P02-99] Main Chassis and Packing Materials

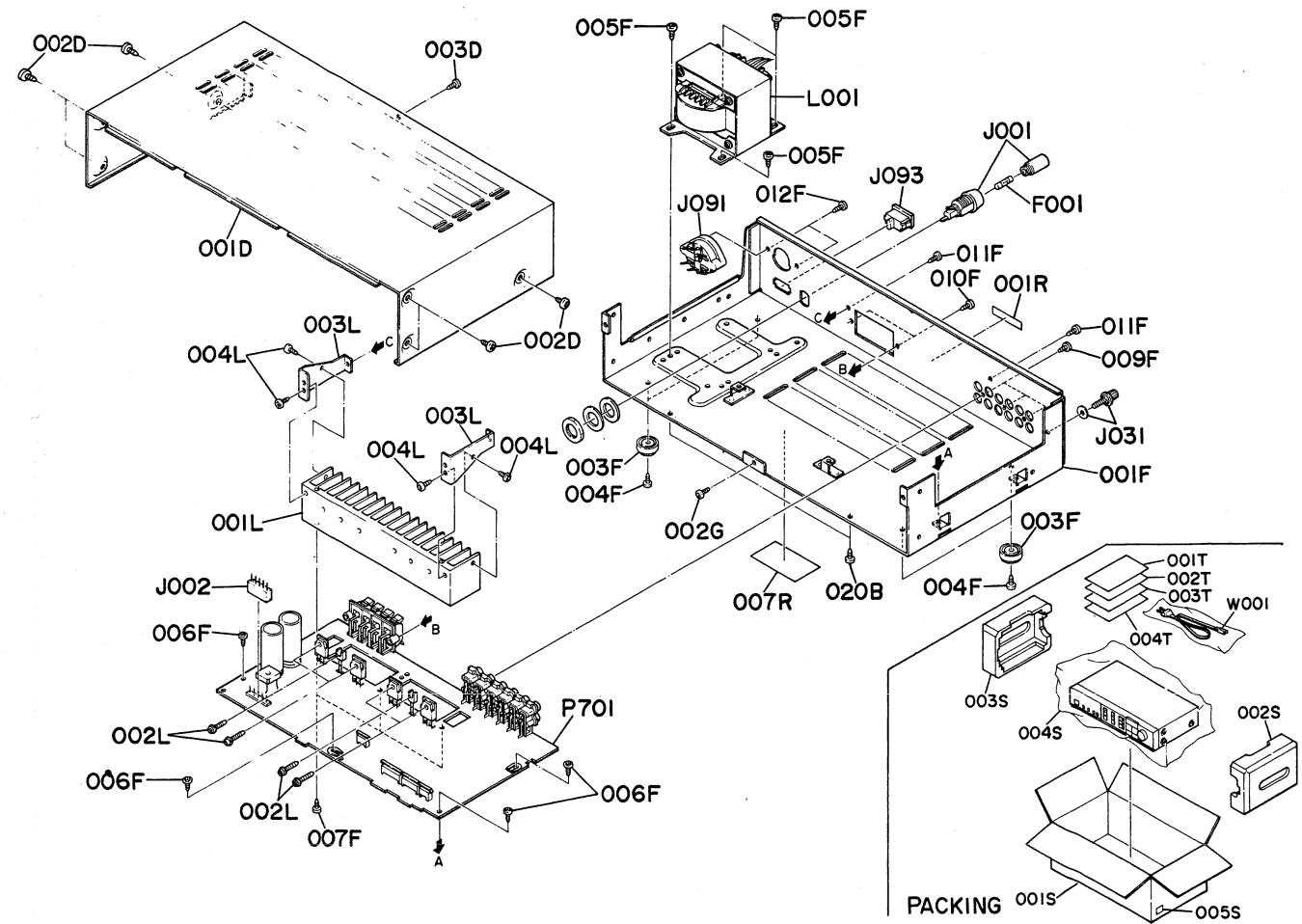

REF. DESIG.	Q'TY	PART NO.	DESCRIPTION
	N A		
A	1	261H248400	Front Panel Assembly [PM340]
A1	1	260H248400	Front Panel Assembly [PM240]
001B	1	260H248010	Front Panel [PM240]
001B	1	261H248010	Front Panel [PM340]
002B	1	261H105050	Chassis, Front
003B	2	158T355010	Lens, Speakers [PM340]
004B	1	261H265030	Indicator, Function
005B	1	261H265010	Indicator, Balance
006B	1	261H270010	Button, Tuner
007B	1	261H270020	Button, Phono
008B	1	261H270030	Button, Video/AUX
009B	1	261H270040	Button, Tape Monitor
010B	1	261H270050	Button, CD
011B	5	261H115010	Spring, Button

REF. DESIG.	Q'TY	PART NO.	DESCRIPTION
	N A		
012B	1	158T270010	Button, Power
013B	1	261H154010	Knob, Volume
014B	2	262H270020	Button, Subsonic/Loudness
015B	3	261H154020	Knob, Bass/Treble/Balance
016B	2	242H270020	Button, Speakers [PM340]
001G	1	261H105010	Chassis, Front
002G	2	51280308B0	B.H. Tapped Screw B3 x 8
003G	2	51100306A9	B.H.M. Screw B3 x 6
004G	4	51280308B0	B.H. Tapped Screw B3 x 8
005G	1	261H053010	Cover, Tone
006G	1	261H265020	Indicator, Tone
007G	2	51100306A9	B.H.M. Screw B3 x 6 [PM340]
008G	1	51280308B0	B.H. Tapped Screw B3 x 8 [PM340]

REF. DESIG.	Q'TY	PART NO.	DESCRIPTION
	N A		
020B	2	51280308B0	B.H. Tapped Screw B3 x 8
001D	1	261H257010	Lid, Top Cover
002D	6	51280408U0	B.H. Tapped Screw B4 x 8
003D	1	51280308B0	B.H. Tapped Screw B3 x 8
001F	1	260H105020	Chassis, Main [PM240]
001F	1	261H105020	Chassis, Main [PM340]
003F	4	416H057010	Leg
004F	4	51280408B0	B.H. Tapped Screw B4 x 8
005F	4	51280408B0	B.H. Tapped Screw B4 x 8
006F	4	51280308B0	B.H. Tapped Screw B3 x 8
007F	3	51280308B0	B.H. Tapped Screw B3 x 8
009F	3	51280308B0	B.H. Tapped Screw B3 x 8
010F	2	51280308B0	B.H. Tapped Screw B3 x 8
011F	2	51280308B0	B.H. Tapped Screw B3 x 8
012F	2	51280308B0	B.H. Tapped Screw B3 x 8
002G	1	51280308B0	B.H. Tapped Screw B3 x 8
001L	1	260H267010	Heatsink [PM240]
001L	1	261H267010	Heatsink [PM340]
002L	6	51780312B0	Fin Neck B.T. Screw B3 x 12
003L	2	261H160010	Bracket, Heatsink
004L	4	51280308B0	B.H. Tapped Screw B3 x 8
001R	1	2112265110	Indicator, Serial No.
007R	1	2911861110	Label

REF. DESIG.	Q'TY	PART NO.	DESCRIPTION
	N A		
△ F001	1	FS10100800	Fuse 1A 250V [PM240]
△ F001	1	FS10125800	Fuse T1.25A 250V [PM340]
△ J001	1	YJ08000290	Jack, Fuse Holder
J002	1	YJ06001050	Jack, 5P
J031	1	YL03010250	Terminal, GND
△ J091	1	BY05080050	Voltage Selector
△ J093	1	YP04000580	Plug, AC Inlet
△ L001	1	TS16803010	Power Transformer [PM240]
△ L001	1	TS17629010	Power Transformer [PM340]
001S	1	260H801010	Packing Case [PM240]
001S	1	261H801010	Packing Case [PM340]
002S	1	261H809010	Cushion, R
003S	1	261H809020	Cushion, L
004S	1	9090808030	Polyethylene Sheet
005S	4	9526019030	Serial No. Card
005S	4	9526019060	Serial No. Card
001T	1	262H851310	User Manual
002T	1	261H851320	User Manual, Spec
003T	1	260H856010	Circuit Diagram [PM240]
003T	1	261H856010	Circuit Diagram [PM340]
004T	1	9631000090	Warranty Card
△ W001	1	ZC01805010	A.C. Power Cord
△ W001	1	ZC02006020	A.C. Power Cord

9. ELECTRICAL PARTS LIST

REF. DESIG.	Q'TY		PART NO.	DESCRIPTION
	N	A		
P701	1	1	YK261H1610	(PM340/PM240) P701-MAIN CIRCUIT BOARD P.W. Board, Main
	1	1	ZZ261H8610	P.W. Board Assembly [PM340]
	1	1	ZZ260H8610	P.W. Board Assembly [PM240]
P701-CAPACITORS				
C401	1	1	EA33505030	Elect 3.3 μ F 50V
C402	1	1	EA33505030	Elect 3.3 μ F 50V
C403	1	1	DD15101370	Ceramic 100pF \pm 5%
C404	1	1	DD15101370	Ceramic 100pF \pm 5%
C405	1	1	EA10701030	Elect 100 μ F 10V
C406	1	1	EA10701030	Elect 100 μ F 10V
C407	1	1	DF16332350	Film 3300pF \pm 10%
C408	1	1	DF16332350	Film 3300pF \pm 10%
C409	1	1	DF16123350	Film 0.012 μ F \pm 10%
C410	1	1	DF16123350	Film 0.012 μ F \pm 10%
C411	1	1	EA33505030	Elect 3.3 μ F 50V
C412	1	1	EA33505030	Elect 3.3 μ F 50V
C413	1	1	EA22601630	Elect 22 μ F 16V
C414	1	1	EA22601630	Elect 22 μ F 16V
C415	1	1	DF16182350	Film 1800pF \pm 10% [PM340]
C415	1	1	DF16102350	Film 1000pF \pm 10% [PM240]
C416	1	1	DF16182350	Film 1800pF \pm 10% [PM340]
C416	1	1	DF16102350	Film 1000pF \pm 10% [PM240]
C417	1	1	DK18103310	Ceramic 0.01 μ F
C418	1	1	DK18103310	Ceramic 0.01 μ F
C420	1	1	DK18103310	Ceramic 0.01 μ F
C701	1	1	EA33505030	Elect 3.3 μ F 50V
C702	1	1	EA33505030	Elect 3.3 μ F 50V
C703	1	1	DD15221370	Ceramic 220pF \pm 5%
C704	1	1	DD15221370	Ceramic 220pF \pm 5%
C706	1	1	EA10505030	Elect 1 μ F 50V
C707	1	1	EA22601630	Elect 22 μ F 16V
C708	1	1	EA22601630	Elect 22 μ F 16V
C709	1	1	DD15101370	Ceramic 100pF \pm 5%
C710	1	1	DD15101370	Ceramic 100pF \pm 5%
C711	1	1	EA10505030	Elect 1 μ F 50V
C712	1	1	EA10505030	Elect 1 μ F 50V
C713	1	1	DD15150370	Ceramic 15pF \pm 5%
C714	1	1	DD15150370	Ceramic 15pF \pm 5%
C715	1	1	DF16333350	Film 0.033 μ F \pm 10%
C716	1	1	DF16333350	Film 0.033 μ F \pm 10%
C717	1	1	DD11100370	Ceramic 10pF \pm 0.5pF
C718	1	1	DD11100370	Ceramic 10pF \pm 0.5pF
C719	1	1	EA47505030	Elect 4.7 μ F 50V
C720	1	1	EA47505030	Elect 4.7 μ F 50V
C721	1	1	EA47505030	Elect 4.7 μ F 50V
C722	1	1	EA47505030	Elect 4.7 μ F 50V
C723	1	1	DF16683350	Film 0.068 μ F \pm 10%
C724	1	1	DF16683350	Film 0.068 μ F \pm 10%
C725	1	1	DF16683350	Film 0.068 μ F \pm 10%
C726	1	1	DF16683350	Film 0.068 μ F \pm 10%
C801	1	1	EA10701630	Elect 100 μ F 16V
C802	1	1	EA10701630	Elect 100 μ F 16V
C803	1	1	EB68805060	Elect 6800 μ F 50V
C804	1	1	EB68805060	Elect 6800 μ F 50V
C805	1	1	DK18103560	Ceramic 0.01 μ F

REF. DESIG.	Q'TY		PART NO.	DESCRIPTION
	N	A		
C806	1	1	DK18103560	Ceramic 0.01 μ F
C807	1	1	EA33701630	Elect 330 μ F 16V
C808	1	1	EA10605030	Elect 10 μ F 50V
CK01	1	1	EA10605030	Elect 10 μ F 50V
CK02	1	1	EA22701030	Elect 220 μ F 10V
CK03	1	1	EA10605030	Elect 10 μ F 50V
CK04	1	1	EA33505030	Elect 3.3 μ F 50V
CS01	1	1	EA33505030	Elect 3.3 μ F 50V
CS02	1	1	EA33505030	Elect 3.3 μ F 50V
CS03	1	1	DK18103310	Ceramic 0.01 μ F
CS04	1	1	EA33505030	Elect 3.3 μ F 50V
CS05	1	1	EA33801630	Elect 3300 μ F 16V
CS06	1	1	DK18103310	Ceramic 0.01 μ F
CS07	1	1	DK18103310	Ceramic 0.01 μ F
CS08	1	1	EA10505030	Elect 1 μ F 50V
CS09	1	1	DD15101370	Ceramic 100pF \pm 5%
CS10	1	1	DD15101370	Ceramic 100pF \pm 5%
CV01	1	1	EA33505030	Elect 3.3 μ F 50V
CV02	1	1	EA33505030	Elect 3.3 μ F 50V
P701-RESISTORS (All Resistors are \pm 5% & $\frac{1}{4}$ W)				
R401	1	1	GD05154140	150K Ω
R402	1	1	GD05154140	150K Ω
R403	1	1	GD05683140	68K Ω
R404	1	1	GD05683140	68K Ω
R405	1	1	GD05222140	2.2K Ω
R406	1	1	GD05222140	2.2K Ω
R407	1	1	GD05471140	470 Ω
R408	1	1	GD05471140	470 Ω
R409	1	1	GD05223140	22K Ω
R410	1	1	GD05223140	22K Ω
R411	1	1	GD05274140	270K Ω
R412	1	1	GD05274140	270K Ω
R413	1	1	GG05101140	100 Ω
R414	1	1	GG05101140	100 Ω
R701	1	1	GD05102140	1K Ω
R702	1	1	GD05102140	1K Ω
R703	1	1	GD05104140	100K Ω
R704	1	1	GD05104140	100K Ω
R705	1	1	GD05102140	1K Ω
R706	1	1	GD05102140	1K Ω
R707	1	1	GD05563140	56K Ω
R708	1	1	GD05563140	56K Ω
R709	1	1	GD05182140	1.8K Ω [PM340]
R709	1	1	GD05122140	1.2K Ω [PM240]
R710	1	1	GD05182140	1.8K Ω [PM340]
R710	1	1	GD05122140	1.2K Ω [PM240]
R711	1	1	GD05123140	12K Ω
R712	1	1	GD05123140	12K Ω
R713	1	1	GD05684140	680K Ω
R714	1	1	GD05684140	680K Ω
R715	1	1	GG05047140	4.7 Ω

REF. DESIG.	Q'TY		PART NO.	DESCRIPTION
	N	A		
R716	1	1	GG05047140	4.7Ω
R717	1	1	GG05047140	4.7Ω
R718	1	1	GG05047140	4.7Ω
R719	1	1	GD05563140	56KΩ
R720	1	1	GD05563140	56KΩ
△R721	1	1	BW10000040	0.27Ω, Comp. 3W x 2
△R722	1	1	BW10000040	0.27Ω, Comp. 3W x 2
R723	1	1	GD05151140	150Ω
R724	1	1	GD05151140	150Ω
R725	1	1	GD05272140	2.7KΩ
R726	1	1	GD05272140	2.7KΩ
R727	1	1	GD05151140	150Ω
R728	1	1	GD05151140	150Ω
R729	1	1	GA05047010	4.7Ω 1W
R730	1	1	GA05047010	4.7Ω 1W
R731	1	1	GD05153140	15KΩ
R732	1	1	GD05153140	15KΩ
R733	1	1	GA05100020	10Ω 2W
R734	1	1	GA05100020	10Ω 2W
R735	1	1	RA01010600	100Ω(B), Trimming
R736	1	1	RA01010600	100Ω(B), Trimming
△R737	1	1	NF05100140	10Ω
△R738	1	1	NF05100140	10Ω
△R801	1	1	GA05182020	1.8KΩ 2W [PM340]
△R801	1	1	GA05152020	1.5KΩ 2W [PM240]
△R802	1	1	GA05122020	1.2KΩ 2W [PM340]
△R802	1	1	GA05102120	1KΩ 2W [PM240]
R803	1	1	GA05182020	1.8KΩ 2W
R804	1	1	GD05471140	470Ω
R805	1	1	GA05182020	1.8KΩ 2W
RK01	1	1	GD05123140	12KΩ
RK02	1	1	GD05222140	2.2KΩ
RK03	1	1	GD05123140	12KΩ
RK04	1	1	GD05564140	560KΩ
RK05	1	1	GD05333140	33KΩ
RK06	1	1	GD05563140	56KΩ
RK07	1	1	GD05101140	100Ω
RK08	1	1	GD05223140	22KΩ
RK09	1	1	GD05103140	10KΩ
△RK10	1	1	RF05100140	10Ω, Fusible
△RK11	1	1	RF05100140	10Ω, Fusible
RS01	1	1	GD05392140	3.9KΩ [PM340]
RS01	1	1	GD05562140	5.6KΩ [PM240]
RS02	1	1	GD05392140	3.9KΩ [PM340]
RS02	1	1	GD05562140	5.6KΩ [PM240]
RS03	1	1	GD05104140	100KΩ
RS04	1	1	GD05224140	220KΩ
RS05	1	1	GD05332140	3.3KΩ
RV01	1	1	GD05102140	1KΩ
RV02	1	1	GD05102140	1KΩ
RV03	1	1	GD05105140	1MΩ
RV04	1	1	GD05105140	1MΩ
RV05	1	1	GD05102140	1KΩ
RV06	1	1	GD05102140	1KΩ
RV07	1	1	GD05105140	1MΩ
RV08	1	1	GD05105140	1MΩ
RV09	1	1	GD05221140	220Ω
RV10	1	1	GD05221140	220Ω

REF. DESIG.	Q'TY		PART NO.	DESCRIPTION
	N	A		
RV11	1	1	GD05102140	1KΩ
RV12	1	1	GD05102140	1KΩ
RV13	1	1	GD05105140	1MΩ
RV14	1	1	GD05105140	1MΩ
RV15	1	1	GD05102140	1KΩ
RV16	1	1	GD05102140	1KΩ
RV17	1	1	GD05105140	1MΩ
RV18	1	1	GD05105140	1MΩ
P701-SEMICONDUCTORS				
D701	1	1	HD20001000	Diode 1S1555
D702	1	1	HD20001000	Diode 1S1555
D703	1	1	HD20001000	Diode 1S1555
D704	1	1	HD20001000	Diode 1S1555
D705	1	1	HV00009080	Varistor STV3H(O, Y)
D706	1	1	HV00009080	Varistor STV3H(O, Y)
D801	1	1	HD30038010	Zener HZ11C-1L
D802	1	1	HD30038010	Zener HZ11C-1L
△D803	1	1	HD20022030	Diode DSF10C
△D804	1	1	HD20022030	Diode DSF10C
△D805	1	1	HD20008290	Diode S4VB20
D806	1	1	HD30045010	Zener HZ9C-1L
DK01	1	1	HD20001000	Diode 1S1555
DK02	1	1	HD30023010	Zener HZ6C1L
DK03	1	1	HD20002210	Diode 1S2472
△DK04	1	1	HD20002230	Diode DSF10C
DS01	1	1	HD20001000	Diode 1S1555
DS02	1	1	HD30045010	Zener HZ9C-1L
Q401	1	1	HC10008090	IC 4558DD
Q701	1	1	HT413022B0	Transistor 2SD1302(S, T)
Q702	1	1	HT413022B0	Transistor 2SD1302(S, T)
△Q703	1	1	HC10097060	IC μPC1270H
△Q704	1	1	HC10097060	IC μPC1270H
△Q705	1	1	HT325782B0	Transistor 2SC2578(O, Y) [PM340]
△Q705	1	1	HT326652B0	Transistor 2SC2265(O, Y) [PM240]
△Q706	1	1	HT325782B0	Transistor 2SC2578(O, Y) [PM340]
△Q706	1	1	HT326652B0	Transistor 2SC2665(O, Y) [PM240]
△Q707	1	1	HT111032B0	Transistor 2SA1103(O, Y) [PM340]
△Q707	1	1	HT111352B0	Transistor 2SA1135(O, Y) [PM240]
△Q708	1	1	HT111032B0	Transistor 2SA1103(O, Y) [PM340]
△Q708	1	1	HT111352B0	Transistor 2SA1135(O, Y) [PM240]
Q709	1	1	HT327852B0	Transistor 2SC2785(J, H)
Q710	1	1	HT327852B0	Transistor 2SC2785(J, H)
△Q801	1	1	HT206472F0	Transistor 2SB647(C, D)
△Q802	1	1	FU10215010	Current Protector ICP-F25(1A)
△Q803	1	1	FU10215010	Current Protector ICP-F25(1A)
△Q804	1	1	FU10215010	Current Protector ICP-F25(1A)
QK01	1	1	HT327852B0	Transistor 2SC2785(J, H)
QK02	1	1	HT111752B0	Transistor 2SA1175(J, H)
QK03	1	1	HT327852B0	Transistor 2SC2785(J, H)
QK04	1	1	HT327852B0	Transistor 2SC2758(J, H)
QK05	1	1	HT111752B0	Transistor 2SA1175(J, H)
QS01	1	1	HC10110030	IC LC7815H
QS02	1	1	HC406603C0	IC LC466BH

REF. DESIG.	QTY		PART NO.	DESCRIPTION
	N	A		
J401	1	1	YL01010110	P701-MISCELLANEOUS Terminal, Earth
J701	1	1	YT03080020	Terminal, Speaker
J702	1	1	YJ06002430	Jack, 3P
J703	1	1	YL01010110	Terminal, Earth
J801	1	1	YP06001050	Plug, 5P
JV01	1	1	YT02040470	Terminal, RCA Jack (4P)
JV02	1	1	YT02040470	Terminal, RCA Jack (4P)
JV03	1	1	YT02040470	Terminal, RCA Jack (4P)
JS01	1	1	YJ06002430	Jack, 3P
JS02	1	1	YJ06002460	Jack, 7P
JS03	1	1	YJ06002270	Jack, 8P
L701	1	1	LL23905120	Coil, 1μH
L702	1	1	LL23905120	Coil, 1μH
W701	1	1	YU02220260	Jumper Lead, 2P [PM340]
W703	1	1	YU03140260	Jumper Lead, 3P [PM340]
W704	1	1	YU04140260	Jumper Lead, 4P [PM340]
				(PM340/PM240) PE01-VOLUME CIRCUIT BOARD
PE01	1	1	YK261H1620	P.W. Board, Volume
	1	1	ZZ261H8620	P.W. Board Assembly
				PE01-CAPACITORS
CE01	1	1	EA22601630	Elect 22μF 16V
CE02	1	1	EA22601630	Elect 22μF 16V
CE03	1	1	EA22701030	Elect 220μF 10V
CE04	1	1	EA22701030	Elect 220μF 10V
CE05	1	1	EA22601630	Elect 22μF 16V
CE06	1	1	EA22601630	Elect 22μF 16V
CE07	1	1	DF16332350	Film 3300pF ±10%
CE08	1	1	DF16332350	Film 3300pF ±10%
CE09	1	1	DF16473350	Film 0.047μF ±10%
CE10	1	1	DF16473350	Film 0.047μF ±10%
CE11	1	1	DF16152350	Film 1500pF ±10%
CE12	1	1	DF16152350	Film 1500pF ±10%
CE13	1	1	DF16103350	Film 0.01μF ±10%
CE14	1	1	DF16103350	Film 0.01μF ±10%
CE15	1	1	EA22601630	Elect 22μF 16V
CE16	1	1	EA22601630	Elect 22μF 16V
CE17	1	1	DF16333350	Film 0.033μF ±10%
CE18	1	1	DF16333350	Film 0.033μF ±10%
CE19	1	1	DK16821300	Ceramic 820pF ±10%
CE20	1	1	DK16821300	Ceramic 820pF ±10%
CE21	1	1	DF15104350	Film 0.1μF ±5%
CE22	1	1	DF15104350	Film 0.1μF ±5%
CE25	1	1	DD15220370	Ceramic 22pF ±5%
CE26	1	1	DD15220370	Ceramic 22pF ±5%
CE27	1	1	EA10701030	Elect 100μF 10V
CE28	1	1	EA10701030	Elect 100μF 10V

REF. DESIG.	QTY		PART NO.	DESCRIPTION
	N	A		
				PE01-RESISTORS (All Resistors are ±5% & ¼W)
RE01	1	1	GD05683140	68KΩ
RE02	1	1	GD05683140	68KΩ
RE03	1	1	GD05224140	220KΩ
RE04	1	1	GD05224140	220KΩ
RE05	1	1	GD05222140	2.2KΩ
RE06	1	1	GD05222140	2.2KΩ
RE07	1	1	GD05221140	220Ω
RE08	1	1	GD05221140	220Ω
RE09	1	1	GD05222140	2.2KΩ
RE10	1	1	GD05222140	2.2KΩ
RE11	1	1	GD05152140	1.5KΩ
RE12	1	1	GD05152140	1.5KΩ
RE13	1	1	GD05221140	220Ω
RE14	1	1	GD05221140	220Ω
RE15	1	1	GD05472140	4.7KΩ
RE16	1	1	GD05472140	4.7KΩ
RE17	1	1	GD05333140	33KΩ
RE18	1	1	GD05333140	33KΩ
RE19	1	1	GD05223140	22KΩ
RE20	1	1	GD05223140	22KΩ
RE21	1	1	GD05272140	2.7KΩ
RE22	1	1	GD05272140	2.7KΩ
RE23	1	1	GD05682140	6.8KΩ
RE24	1	1	GD05682140	6.8KΩ
RE25	1	1	GD05153140	15KΩ
RE26	1	1	GD05153140	15KΩ
RE27	1	1	GD05182140	1.8KΩ
RE28	1	1	GD05182140	1.8KΩ
RE29	1	1	GG05101140	100Ω
RE30	1	1	GG05101140	100Ω
RE31	1	1	RS01040320	100KΩ(C) x 2, Variable
RE32	1	1	RS01040320	100KΩ(C) x 2, Variable
RE33	1	1	RM01040840	100KΩ(B), Variable
RE34	1	1	RX02040080	200KΩ(W), Variable
RE35	1	1	GD05822140	8.2KΩ
RE36	1	1	GD05822140	8.2KΩ
RE37	1	1	GD05223140	22KΩ
RE38	1	1	GD05223140	22KΩ
RY01	1	1	GD05471140	470Ω
RY02	1	1	GD05104140	100KΩ
RY03	1	1	GD05471140	470Ω
RY04	1	1	GD05104140	100KΩ
RY05	1	1	GD05471140	470Ω
RY06	1	1	GD05104140	100KΩ
RY07	1	1	GD05471140	470Ω
RY08	1	1	GD05104140	100KΩ
RY09	1	1	GD05471140	470Ω
RY10	1	1	GD05104140	100KΩ
RY11	1	1	GD05390140	39Ω
RY12	1	1	GD05390140	39Ω
RY13	1	1	GD05390140	39Ω
RY14	1	1	GD05390140	39Ω
RY15	1	1	GD05390140	39Ω

REF. DESIG.	QTY		PART NO.	DESCRIPTION
	N	A		
QE01	1	1	HC10008090	PE01-SEMICONDUCTORS IC 4458DC
QY01	1	1	HT111752B0	Transistor 2SA1175(J, H)
QY02	1	1	HT111752B0	Transistor 2SA1175(J, H)
QY03	1	1	HT111752B0	Transistor 2SA1175(J, H)
QY04	1	1	HT111752B0	Transistor 2SA1175(J, H)
QY05	1	1	HT111752B0	Transistor 2SA1175(J, H)
SE01	1	1	SP02011090	PE01-MISCELLANEOUS Push Switch, Loudness
SE02	1	1	SP02011090	Push Switch, Low Filter
SY01	1	1	SP01010840	Push Switch, Tape 1
SY02	1	1	SP01010840	Push Switch, Phono
SY03	1	1	SP01010840	Push Switch, Tape 2
SY04	1	1	SP01010840	Push Switch, CD
SY05	1	1	SP01010840	Push Switch, Tuner
VY01	1	1	IN10080620	Lamp 50mA 8V
VY02	1	1	IN10080620	Lamp 50mA 8V
VY03	1	1	IN10080620	Lamp 50mA 8V
VY04	1	1	IN10080620	Lamp 50mA 8V
VY05	1	1	IN10080620	Lamp 50mA 8V
WE01	1	1	YU03160260	Jumper Lead, 3P
WE02	1	1	YU03240260	Jumper Lead, 3P
WY01	1	1	YU07160260	Jumper Lead, 7P
WY02	1	1	YU08160260	Jumper Lead, 8P
				(PM340, ONLY) PN01-SPEAKER SWITCH CIRCUIT BOARD
PN01	1	1	YK261H1650	P.W. Board, Speaker Switch
	1	1	ZZ261H8650	P.W. Board Assembly
SN01	1	1	SP04020440	Push Switch
WN01	1	1	YU03120260	Jumper Lead, 3P
				(PM340/PM240) PP01-POWER SWITCH CIRCUIT BOARD
PP01	1	1	YK261H1630	P.W. Board, Power Switch
	1	1	ZZ261H8630	P.W. Board Assembly
ΔG001	1	1	DK18103840	Ceramic Cap. 0.01μF 250V
ΔS001	1	1	SP01010650	Push Switch

(W01-99)	Assembly and Wiring
(T01-99)	Adjustment
(X01-00)	Correction

REF. DESIG.	QTY		PART NO.	DESCRIPTION
	N	A		
				(PM340/PM240) PW01-HEAD PHONE JACK CIRCUIT BOARD
PW01	1	1	YK261H1640	P.W. Board, Head Phone Jack
	1	1	ZZ261H8640	P.W. Board Assembly [PM340]
	1	1	ZZ260H8640	P.W. Board Assembly [PM240]
RW01	1	1	GA05331010	Resistor 330Ω ±5% 1W
RW02	1	1	GA05331010	Resistor 330Ω ±5% 1W
JW01	1	1	YJ01001790	Jack, Head Phone [PM340]
JW01	1	1	YJ01001770	Jack, Head Phone [PM240]
				(PM340, ONLY) PX01-SPEAKER LAMP CIRCUIT BOARD
PX01	1	1	YK261H1660	P.W. Board, Speaker Lamp
	1	1	ZZ261H8660	P.W. Board Assembly
RX01	1	1	GD05390140	Resistor 39Ω ±5% ¼W
RX02	1	1	GD05390140	Resistor 39Ω ±5% ¼W
VX01	1	1	IN10080620	Lamp 50mA 8V
VX02	1	1	IN10080620	Lamp 50mA 8V

NOTE ON SAFETY :
Symbol Δ Fire or electrical shock hazard. Only original parts should be used to replace any part marked with symbol Δ. Any other component substitution (other than original type), may increase risk of fire or electrical shock hazard.

10. TECHNICAL SPECIFICATIONS (Model PM340)

AUDIO SECTION

POWER OUTPUT PER CHANNEL

DIN 4 OHMS	55 W
RMS 4 OHMS	45 W
DIN 8 OHMS	50 W
RMS 8 OHMS	40 W
TOTAL HARMONIC DISTORTION AT RMS 8 OHMS	0.05%
I.M. DISTORTION	0.05%
DAMPING FACTOR 8 OHMS (1 kHz)	55

MM CARTRIDGE INPUT

Frequency Response (RIAA) 20 Hz — 20 kHz	±0.5 dB
Signal-to-Noise Ratio	72 dB
Input Impedance	47 k ohms
Input Capacitance	100 pF
Input Sensitivity	2.5 mV

AUX. INPUT

Input Impedance	25 k ohms
Input Sensitivity	150 mV
Frequency Response (±2 dB)	10 Hz — 50 kHz
Signal-to-Noise Ratio	92 dB

OUTPUT VOLTAGE

Tape Out (Input 7.75 mV)	417 mV
--------------------------	--------

OUTPUT IMPEDANCE

Tape Out	300 ohms
----------	----------

GENERAL

Power Requirements	110/120/220/240V AC, 50/60 Hz
Power Consumption at Rated Output, both Channels Operating	200 W
Dimensions	
Panel Width	416 mm
Panel Height	85 mm
Depth	225 mm
Weight	
Unit Alone	5.0 kg

TECHNICAL SPECIFICATIONS (Model PM240)

AUDIO SECTION

POWER OUTPUT PER CHANNEL

DIN 8 OHMS	40 W
RMS 8 OHMS	35 W
TOTAL HARMONIC DISTORTION AT RMS 8 OHMS	0.05%
I.M. DISTORTION	0.05%
DAMPING FACTOR 8 OHMS (1 kHz)	45

MM CARTRIDGE INPUT

Frequency Response (RIAA) 20 Hz — 20 kHz	±0.5 dB
Signal-to-Noise Ratio	70 dB
Input Impedance	47 k ohms
Input Capacitance	100 pF
Input Sensitivity	2.5 mV

AUX. INPUT

Input Impedance	25 k ohms
Input Sensitivity	150 mV
Frequency Response (±2 dB)	10 Hz — 50 kHz
Signal-to-Noise Ratio	91 dB

OUTPUT VOLTAGE

Tape Out (Input 7.75 mV)	415 mV
--------------------------	--------

OUTPUT IMPEDANCE

Tape Out	300 ohms
----------	----------

GENERAL

Power Requirements	110/120/220/240V AC, 50/60 Hz
Power Consumption at Rated Output, both Channels Operating	170 W
Dimensions	
Panel Width	416 mm
Panel Height	85 mm
Depth	225 mm
Weight	
Unit Alone	4.9 kg

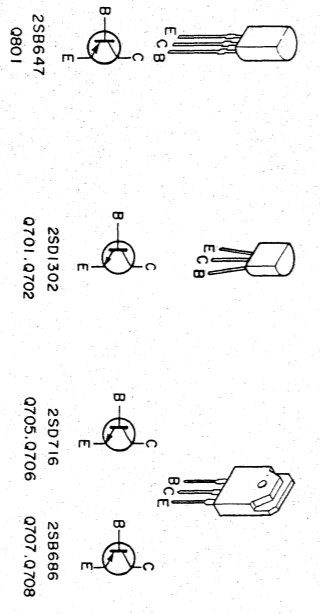
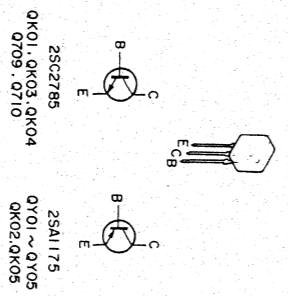
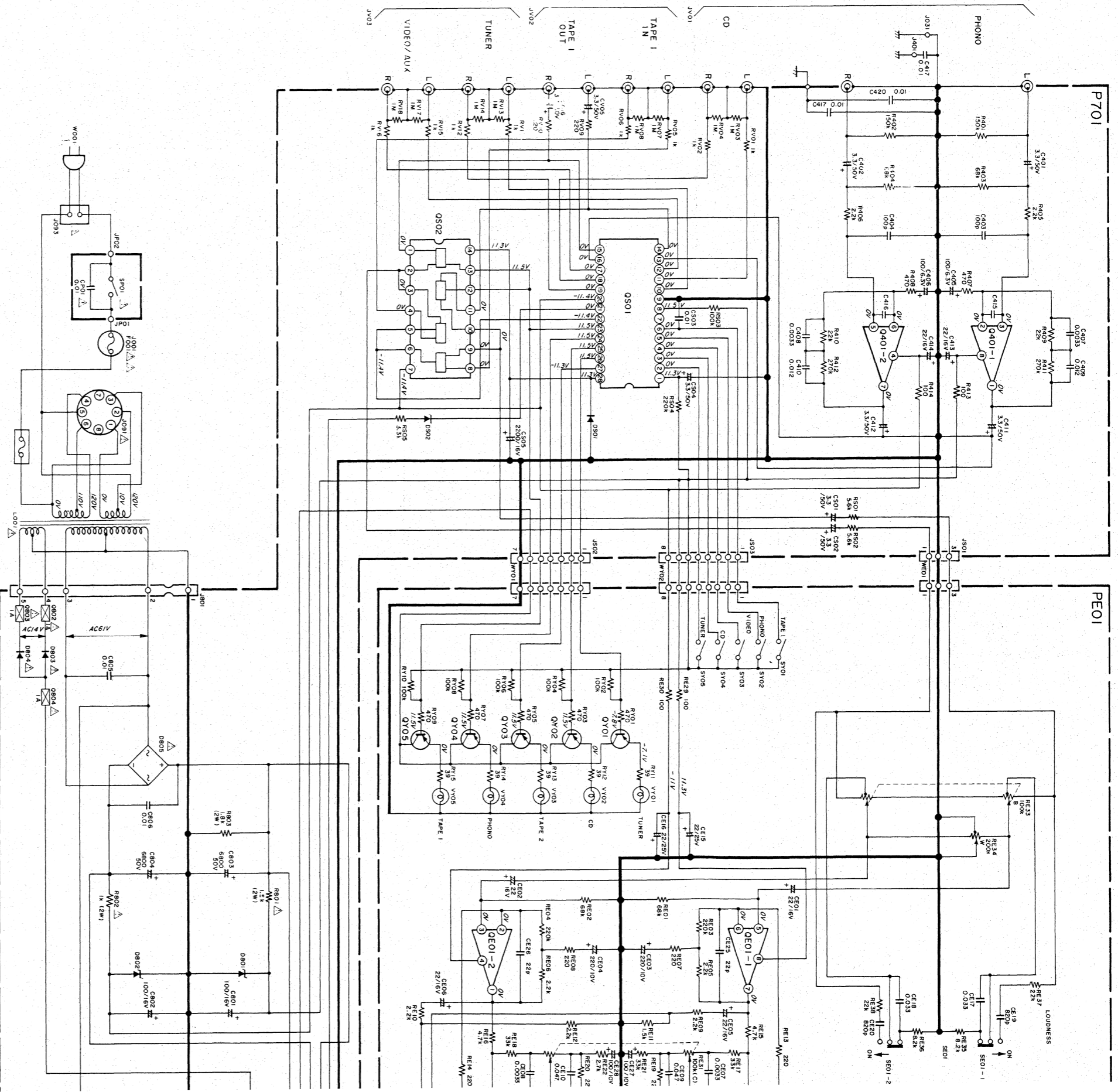

NOTE ON SAFETY :
 Symbol Δ Fire or electrical shock hazard. Only original parts should be used to replace any part marked with symbol Δ . Any other component substitution (other than original type), may increase risk of fire or electrical shock hazard.

Model PM240

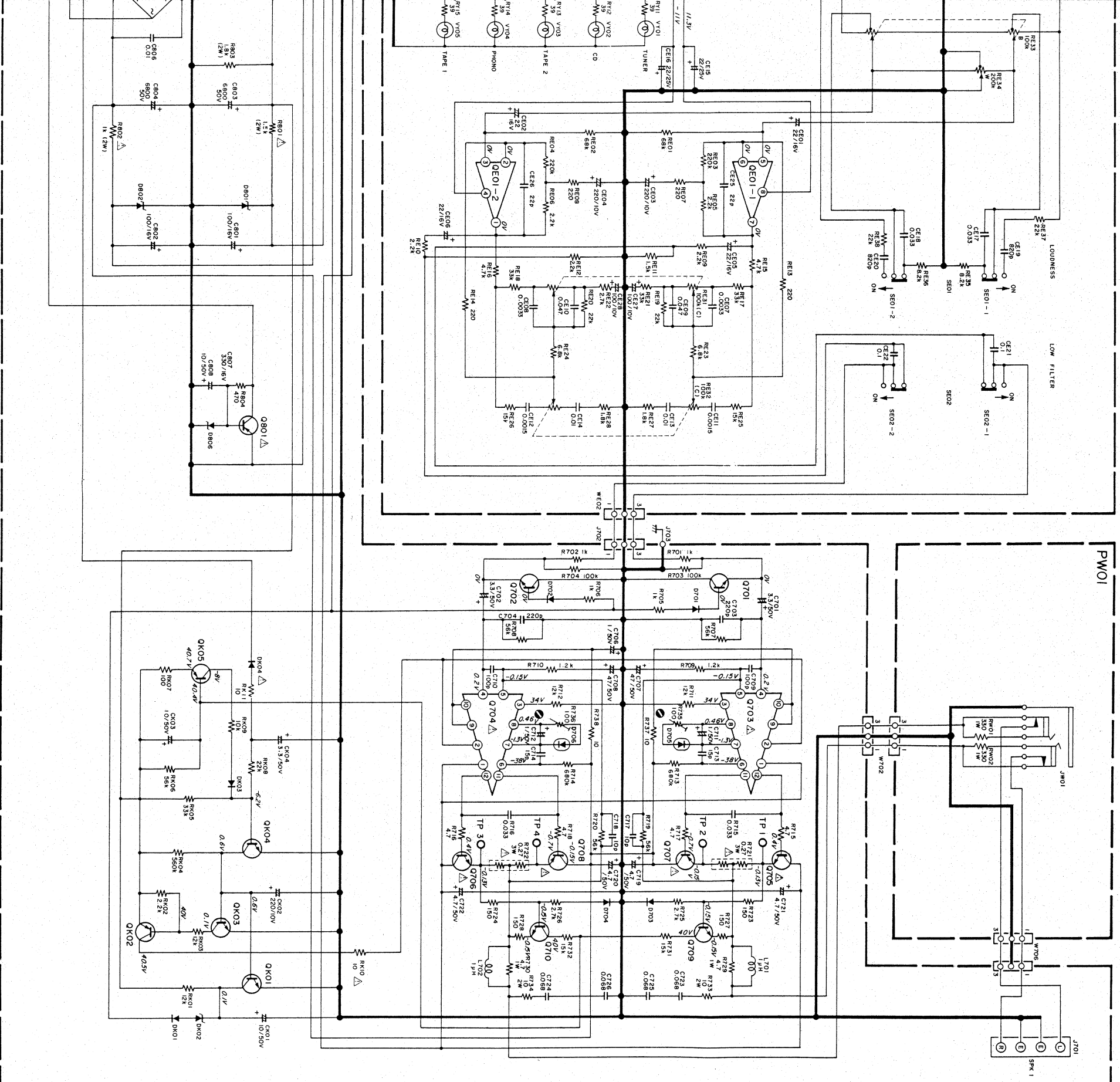

- QEO1, Q401
- HC10008090
- NJM4558D-D
- QY01~QY05, QK02, QK05
- HT111752B0
- 25A11751(J,H)

- QK01, QK03, QK04, Q709, Q710
- HT3278525D
- 25C27851(J,H)

- Q501
- HC10110030
- LC7815H
- Q502
- HC40660300
- LC4066B-H

- Q701, Q702
- HT141302280
- 25013021(S,T)

- Q703, Q704
- HC10097060
- JPC1270H

- Q705, Q706
- HT407162A0
- 25D716R0

- Q707, Q708
- HT206562A0
- 25B647(C,D)

- Q801
- HT206472F0
- 25B647(C,D)

- DK01, DS01, D701~D704
- HD20001000
- 1S1555

- DK02
- HD30023010
- HZ6C-1L

- DK03
- HD20002210
- 1S2472

- DK04, D803, D804
- HD20002230
- DSF10C

- D705, D706
- HY00009080
- STV3H(O,Y)

- D805
- HD20008290
- S4VB20

- D806, DS02
- HD300045010
- HZ9C-1L

- D801, D802
- HD30038010
- HZ11C-1L

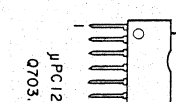
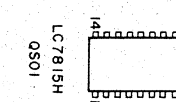
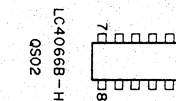
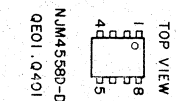
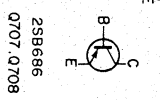
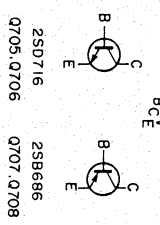
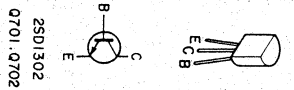

TOP VIEW
1 2 3 4
4 3 2 1

TOP VIEW
1 2 3 4 5 6 7
7 6 5 4 3 2 1

TOP VIEW
1 2 3 4 5 6 7 8 9 10 11 12 13 14
14 13 12 11 10 9 8 7 6 5 4 3 2 1

TOP VIEW
1 2 3 4 5 6 7 8 9 10 11 12
12 11 10 9 8 7 6 5 4 3 2 1

NJM4558D-D
QEO1, Q401

LC4066B-H
Q502

LC7815H
Q501

JPC1270H
Q703, Q704

Components and wiring are subject to change for modification without notice.

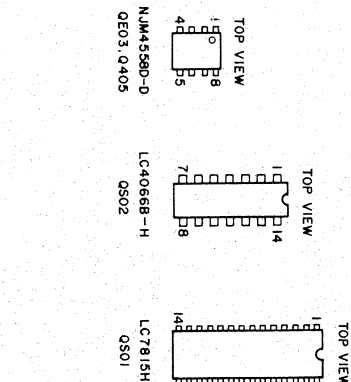
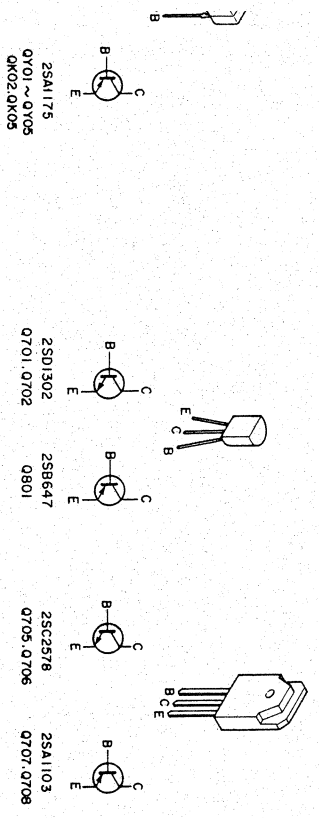
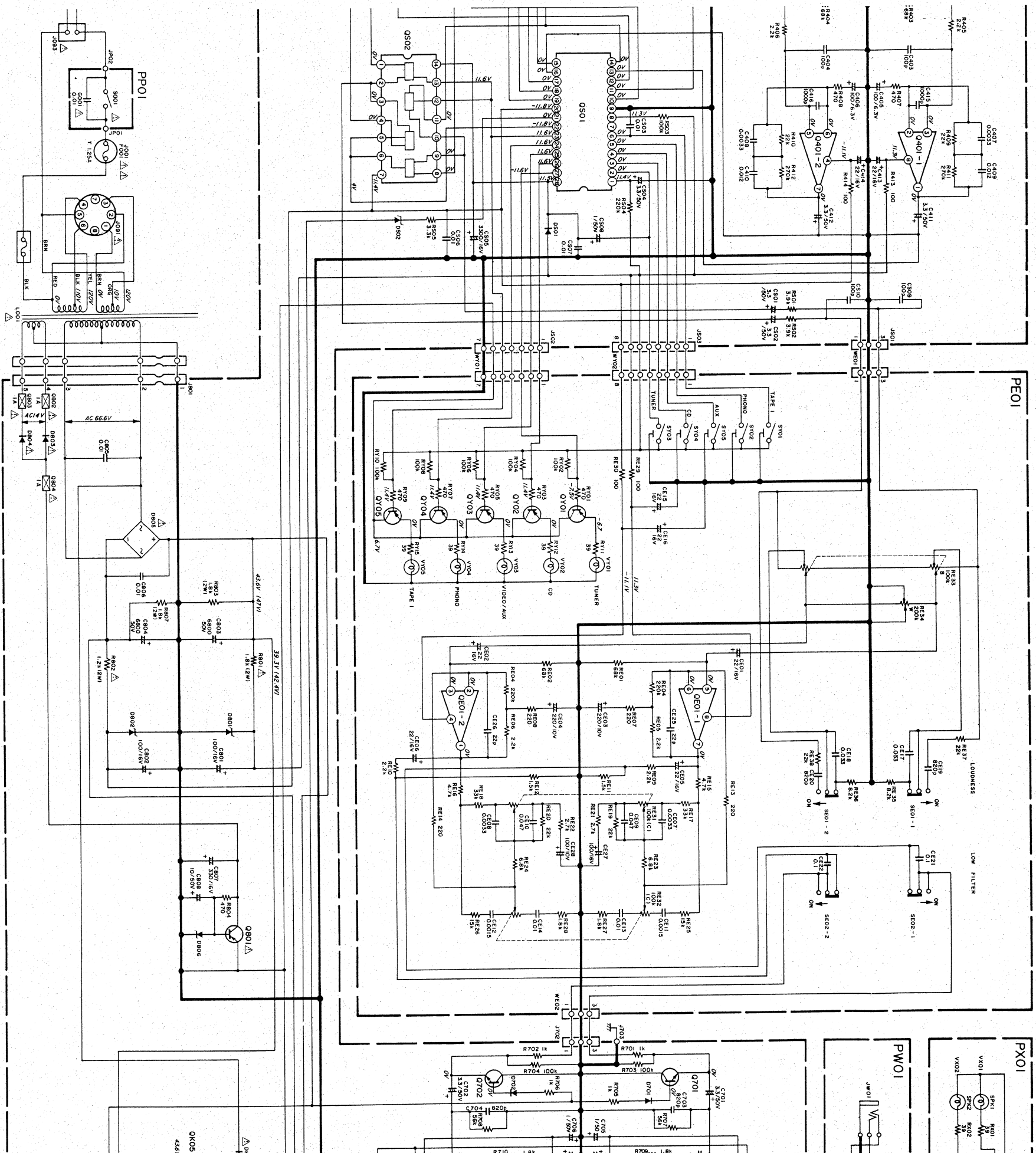

NOTE ON SAFETY :
 Symbol Δ Fire or electrical shock hazard. Only original parts should be used to replace any part marked with symbol Δ . Any other component substitution (other than original type), may increase risk of fire or electrical shock hazard.

Model PM340

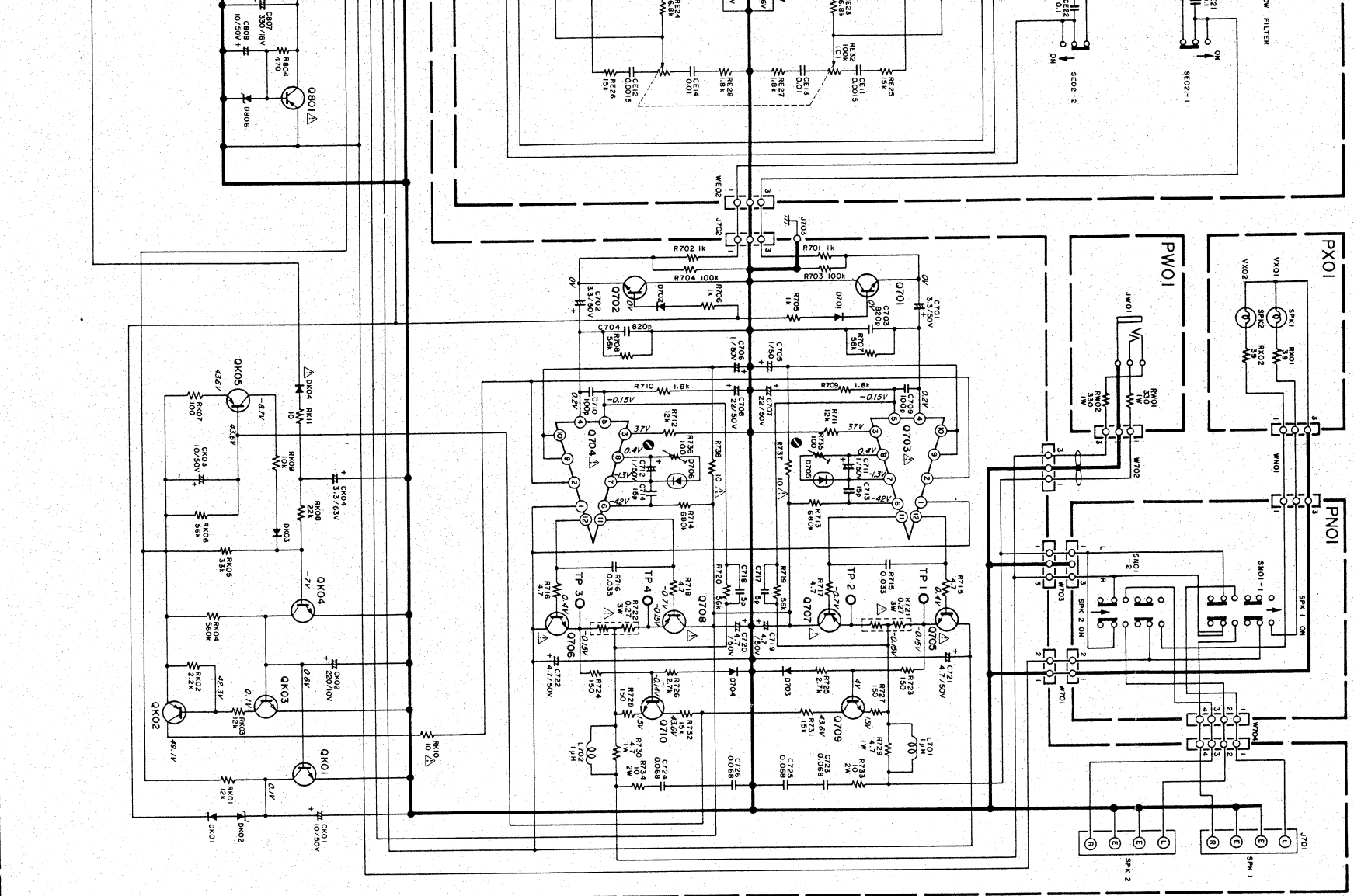

- QY01-QY05, QK02, QK05
HT111752B
ZS41175
- QK01, QK03, QK04, Q709, Q710
HT327522B1
ZSC2785
- Q301
HC10110030
LC7815H
- Q502
HC406603C0
LC40668-H
- Q601, Q602
HC101008090
NJM4558D-D
- Q701, Q702
HT14130Z281
ZS0150Z
- Q703, Q704
HC10097060
JPC1270H
- Q705, Q706
HT3250902A0
ZSC2578
- Q707, Q708
HT111052A0
ZS41103
- Q801
HT206472F0
ZS8647
- DK01, DS01, D701, D704
HD20001001
1S1555
- DK02
HD30045011
HZ6C
- DK03
HD30038011
1S2472
- DK04, DB03, DB04
HD20022031
DSF10C
- D705, D706
HV00009080
STV3H
- DB05
HD20008290
S4VB20
- DS02, DB06
HD30045011
HZ9CIL

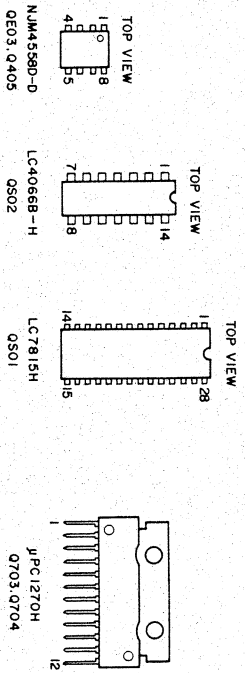

Components and wiring are subject to change for modification without notice.