

SERVICE  
MANUAL

PM251

**marantz**®

model PM251

*Stereo Amplifier*

## MARANTZ DESIGN AND SERVICE

Using superior design and selected high grade components, MARANTZ company has created the ultimate in stereo sound.

Only **original MARANTZ parts** can insure that your MARANTZ product will continue to perform to the specifications for which it is famous.

Parts for your MARANTZ equipment are generally available to our National Marantz Subsidiary or Agent.

### ORDERING PARTS:

Parts can be ordered either by mail or by telex. In both cases, correct part number has to be specified. If you order by mail, fulfill MARANTZ order forms.

The following information must be supplied to eliminate delays in processing your order:

1. Complete address
2. Complete part numbers and quantities required
3. Description of parts
4. Model number for which part is required
5. Way of shipment
6. Signature: any order form or telex must be signed otherwise such part order will be considered as null and void.

### PARTS ORDERING

Parts may be ordered at the following addresses:

**AUSTRIA**  
HORNYPHON  
Vertriebsgesellschaft GmbH  
Wienerbergstrasse 1  
A 1101 Wien  
Austria  
Telex: 132.332

**AUSTRALIA**  
MARANTZ AUSTRALIA  
PTY., Ltd.  
19 Chard Road  
Brookvale, NSW 2100  
Australia  
Telex: 24121

**BELGIUM**  
SVD DIVISION MARANTZ  
Industrialaan 1  
1720 Groot-Bijgaarden  
Belgium  
Telex: 24466

**CHILE**  
MARANTZ  
DIVISION OF PHILIPS S.A.  
AV. Santa Maria, 0760  
Casilla 2687  
Santiago  
Telex: 240.239

**DENMARK**  
MARANTZ  
DIVISION OF PHILIPS  
SERVICE A/S  
Prags Boulevard 80  
Postbox 1919  
DK-2300 København S  
Denmark  
Telex: 31201

**EIRE**  
MARANTZ IRELAND Ltd.  
Newstead  
Glonkeagh  
Dublin 4  
Telex: 25200

**FINLAND**  
MARANTZ  
DIVISION OF OY PHILIPS Ab  
Kaivokatu 8  
00100 Helsinki  
Finland  
Telex: 124811

**FRANCE**  
MARANTZ FRANCE  
4 Rue Bernard Palissy  
92600 Asnières  
France  
Telex: 611651

**GERMANY**  
MARANTZ GERMANY GmbH  
Max-Planck-Strasse 22  
6072 Dreieich 1  
Germany  
Telex: 529821

**THE NETHERLANDS**  
MARANTZ  
De Limiet 3  
4131 NR Vianen  
The Netherlands  
Telex: 47679

**NORWAY**  
MARANTZ  
DIVISION OF PHILIPS A/S  
Sandstuveien 40  
Oslo 6  
Norway  
Telex: 72640

**GREAT BRITAIN**  
MARANTZ AUDIO U.K. Ltd  
Unit 15/16  
Saxon Way Industrial Estate  
Moor Lane  
Harmondsworth UB7 0LW  
Great Britain  
Telex: 935196

**GREECE**  
ADAMCO S.A.  
P.O.Box 21025  
Hippocrates Street 188  
Athens 11410  
Greece  
Telex: 216.795

**ITALY**  
MARANTZ ITALIANA S.p.A.  
Via Monte Napoleone 10  
20121 Milano  
Italia

**JAPAN**  
MARANTZ JAPAN, Inc.  
35-1, 7-chome, Sagamiono  
Sagamihara-shi, Kanagawa  
Japan

**KUWAIT**  
AL ALAMIAH ELECTRONICS  
Ussama Building  
Fahd al Saleem Street  
P.O.Box 23781  
Safat-Kuwait  
Telex: 22694

**SAUDI ARABIA**  
AL ALAMIAH ELECTRONICS  
P.O.Box 5954  
University Street  
Riyadh 11432  
Saudi Arabia  
Telex: 201530

**SOUTH AFRICA**  
MARANTZ  
DIVISION OF PHILIPS S.A.  
Rainer House  
Ove Street, 10  
Doornfontein  
Johannesburg  
Telex: 483.456

**SPAIN**  
PHONO S.A.  
Ignacio Iglesias 10  
Badalona (Barcelona)  
Spain  
Telex: 59355

**SWEDEN**  
MARANTZ  
DIVISION OF PHILIPS  
Försäljning AB  
Tegeluddsvägen 1  
S-115 84 Stockholm  
Sweden  
Telex: 14060

**SWITZERLAND**  
DYNAVOX ELECTRONICS  
Route de Villars 105  
1701 Fribourg  
Switzerland  
Telex: 942377

**TURKEY**  
DOGRUOL Ltd.  
I.M.C.  
6 Blok N°6310  
Unkapani  
Istanbul  
Turkey  
Telex: 22085

**MALTA**  
CACHIA & GALEA  
Republic Street, 68D  
Valetta  
Telex: 1682

**U.S.A.**  
MARANTZ COMPANY, Inc.  
National Service Department  
P.O.Box 577  
Chatsworth, CA 91311  
U.S.A.

### TECHNICAL ASSISTANCE

Should you require any other technical support, do not hesitate to contact the Technical Department of MARANTZ EUROPE & Co.

Avenue Louise 326 - Bte. 32

B-1050 Brussels

Belgium

Telephone: (02) 6407830 (10 l)

Telex: 26602

Fax.: (02) 649.29.20

All of the above locations are fully equipped to take care of your total service needs. Because various countries have differing configuration requirements, it is necessary that you contact the service facility in your particular country. In the event that there is no service location listed for your country, please, contact the nearest facility for the necessary assistance.

In case of difficulties, do not hesitate to contact the Technical Department at abovementioned address.

# marantz®

## TABLE OF CONTENTS

SECTION	PAGE
INTRODUCTION .....	1
1. P.W. BOARDS .....	1
2. VOLTAGE CONVERSION .....	1
3. TEST EQUIPMENT REQUIRED FOR SERVICING .....	2
4. BLOCK DIAGRAM .....	2
5. DIAGRAM AND COMPONENT LOCATIONS .....	3
5.1 Volume Assembly (PE01) Schematic Diagram and Component Locations .....	3
5.2 Speaker Switch Assembly (PN01) Schematic Diagram and Component Locations .....	4
5.3 Power Switch Assembly (PP01) Schematic Diagram and Component Locations .....	4
5.4 Headphone Jack Assembly (PW01) Schematic Diagram and Component Locations .....	5
5.5 Main Amp. Assembly (P701) Schematic Diagram and Component Locations .....	6
5.6 Speaker Lamp Assembly (PX01) Schematic Diagram and Component Locations .....	6
6. EXPLODED VIEW AND PARTS LIST .....	10
7. ELECTRICAL PARTS LIST .....	12
8. TECHNICAL SPECIFICATIONS .....	15
9. SCHEMATIC DIAGRAM .....	16

### How to use this service manual

- The "Common parts" which Marantz Japan, Inc. has established are eliminated from this service manual.
- These "Common parts" are applied to all models in the service manuals arranged and issued by MJI.
- To indicate clearly the common parts in the schematic diagram, a line is drawn above or under the Ref. Desig. No. of applicable parts.
- "Common parts" can be supplied from the Marantz service center as ever.  
In case of ordering, please establish the parts number of 10 figures following the procedure mentioned in this service manual "How to establish the parts number for common parts".

#### (NOTE)

When you order parts to the Marantz parts center, please take notice of the following points.

- 1) Please correctly write the parts number of 10 figures following the rule.
- 2) Since ordering parts by the Ref. Desig. No. or ratings indicated in the schematic diagram does not satisfy the above conditions, the Marantz parts supply system does not work properly.  
As this case is apt to cause a trouble, please pay attention to it.

# MODEL PM251 STEREO AMPLIFIER

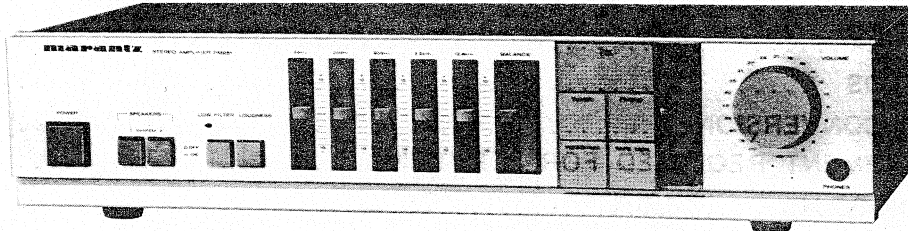

## INTRODUCTION

This service manual was prepared for use by Authorized Warranty Stations and contains service information for the Marantz Model PM251 Stereo Amplifier.

Servicing information and voltage data included in this manual are intended for use by knowledgeable and experienced personnel only. All instructions should be read carefully. No attempt should be made to proceed without a good understanding of circuitry operation.

The parts list furnishes complete ordering information. Most replacement parts should be ordered from the Marantz Company. However, a simple description is included for parts which can be obtained locally.

## 1. P.W. BOARDS

As can be seen from the circuit diagram the chassis of Model PM251 consists of the following units. Each unit mounted on a printed circuit board is described within the square enclosed by a bold dotted line on the circuit diagram.

1. Main Amp. . . . . mounted on P.W. Board P701
2. Volume . . . . . mounted on P.W. Board PE01
3. Speaker Switch . . . . . mounted on P.W. Board PN01
4. Power Switch . . . . . mounted on P.W. Board PP01
5. Headphone . . . . . mounted on P.W. Board PW01
6. Speaker Lamp . . . . . mounted on P.W. Board PX01

## 2. VOLTAGE CONVERSION

### • EUROPEAN MODEL ONLY

To convert the unit to a different power source voltage, change the position as illustrated in the drawing below.

**CAUTION**  
DISCONNECT POWER SUPPLY CORD FROM AC OUTLET BEFORE CONVERTING VOLTAGE.

Voltage Conversion Chart

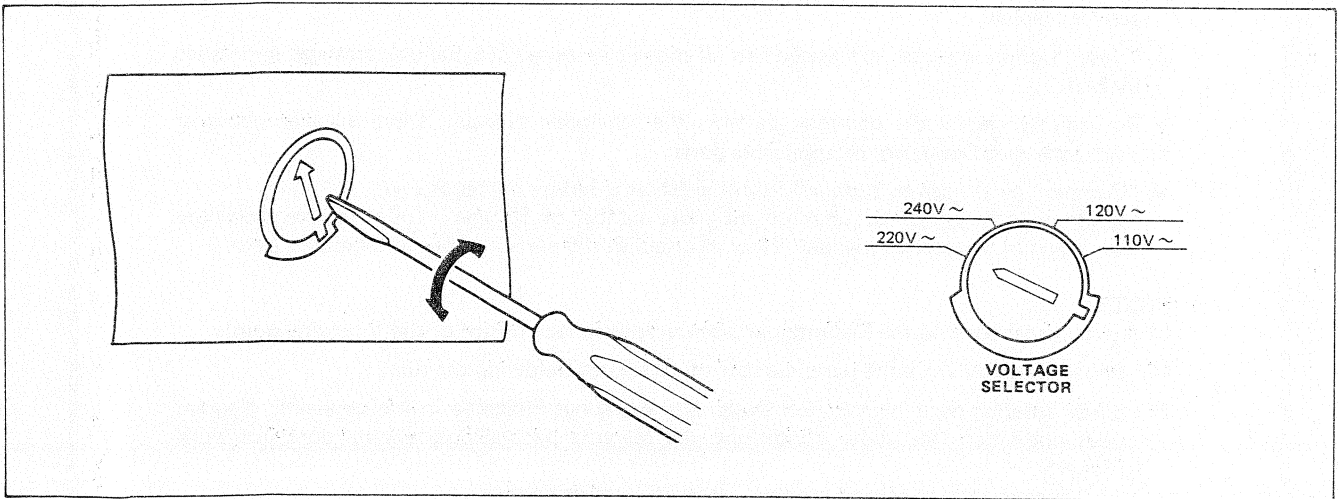

**Note on safety:** Symbol  $\triangle$  Fire or electrical shock hazard. Only original parts should be used to replace any part marked with symbol  $\triangle$ . Any other component substitution (other than original type), may increase risk of fire or electrical shock hazard.

M4282



### 3. TEST EQUIPMENT REQUIRED FOR SERVICING

This table lists the test equipment required for servicing the Model PM251 Stereo Amplifier.

Item	Use
Distortion Analyzer	Distortion measurements
Audio Oscillator	Sinewave and squarewave signal source
AC VTVM	Voltage measurements (AC)
Oscilloscope	Waveform analysis and trouble shooting and ASO alignment
Circuit Tester	Trouble shooting
DC VTVM	Voltage measurements (DC)
AC Wattmeter	Monitors primary power to amplifier
Line Voltmeter	Monitors potential of primary power to amplifier
Variable Autotransformer (0 ~ 140V AC, 10A)	Adjust level of primery power to amplifier
Shorting Plug	Shorts amplifier input to eliminate noise pickup

### 4. BLOCK DIAGRAM

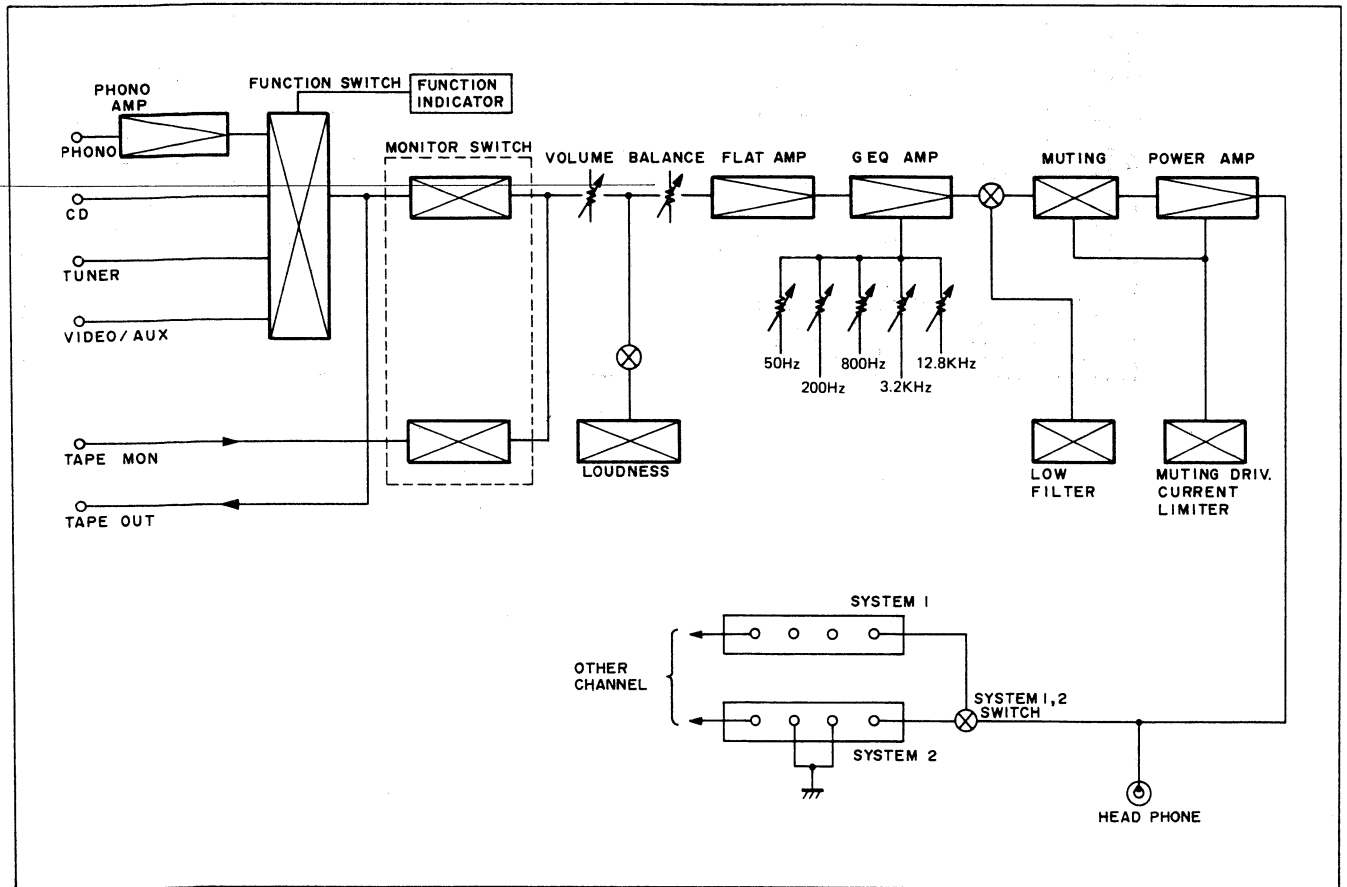

# 5. DIAGRAM AND COMPONENT LOCATIONS

## 5.1 Volume Assembly (PE01) Schematic Diagram and Component Locations

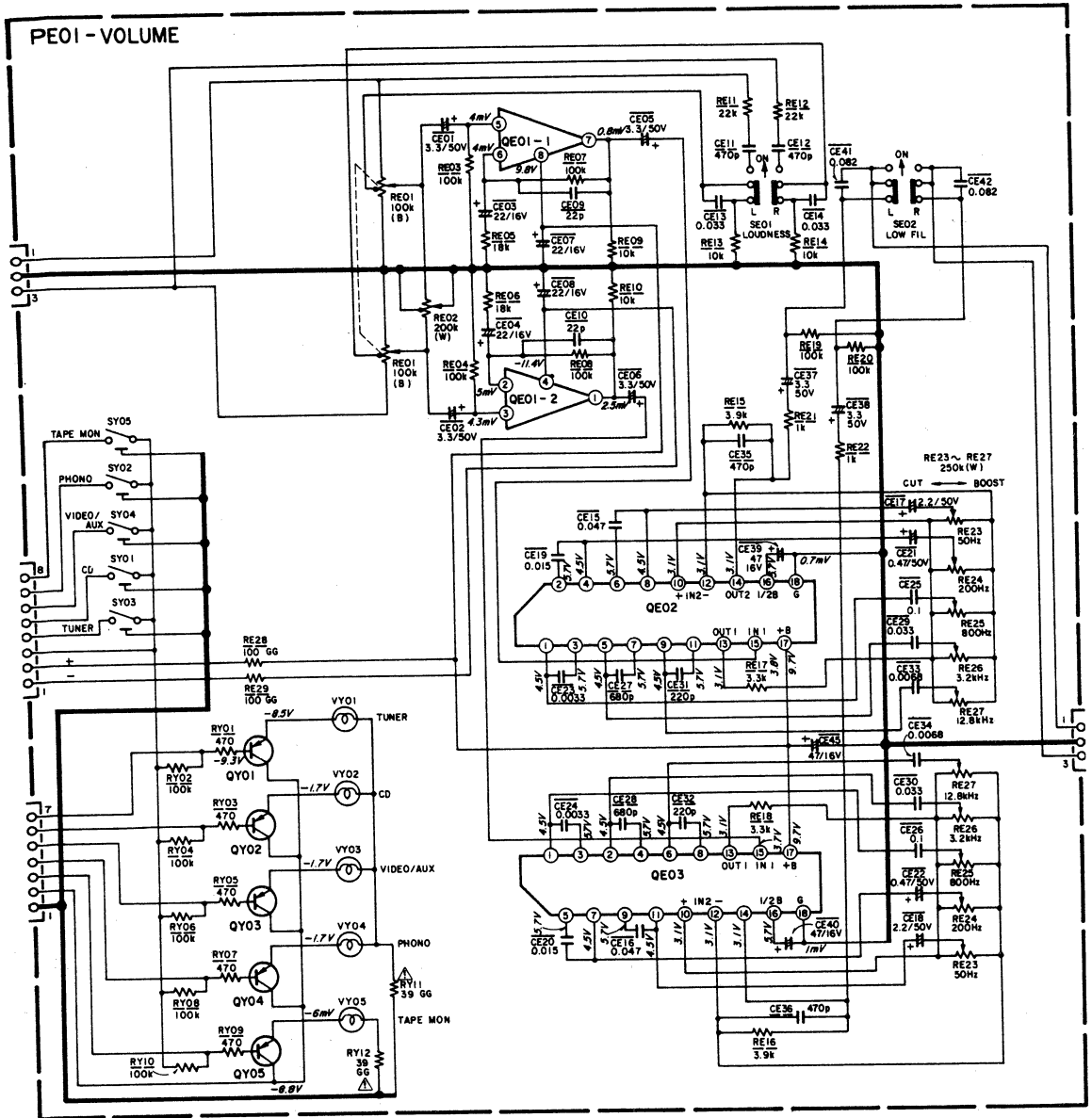

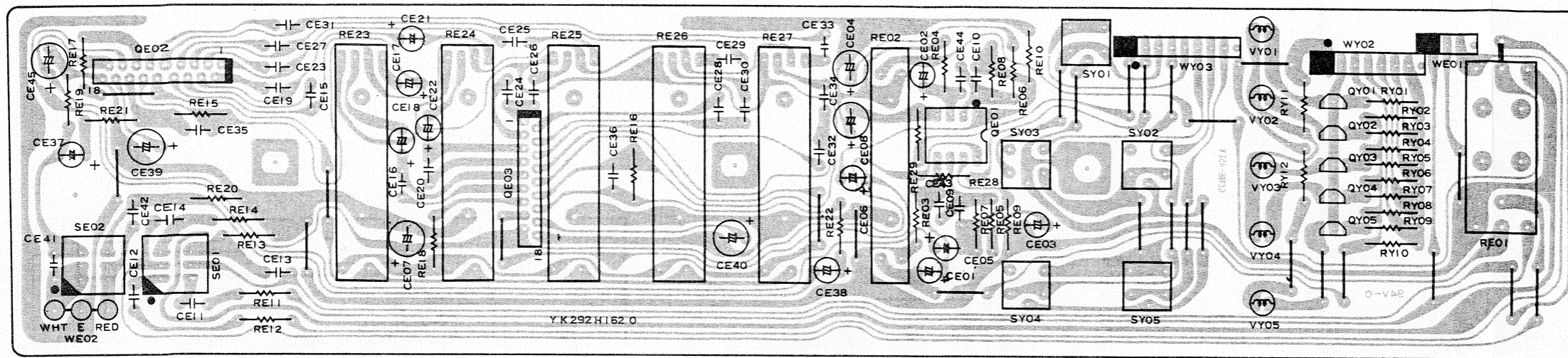

5.2 Speaker Switch Assembly (PN01)  
Schematic Diagram and Component Locations

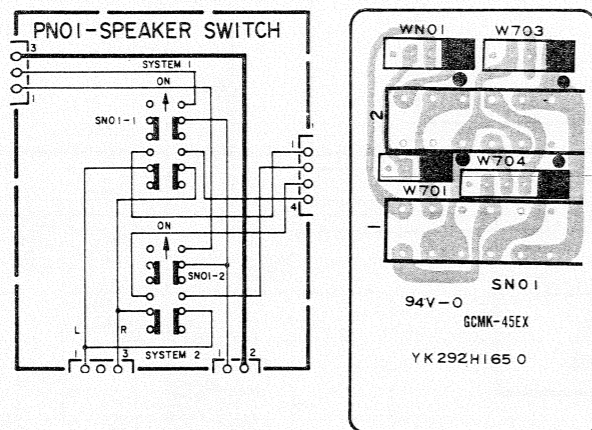

5.3 Power Switch Assembly (PP01)  
Schematic Diagram and Component Locations

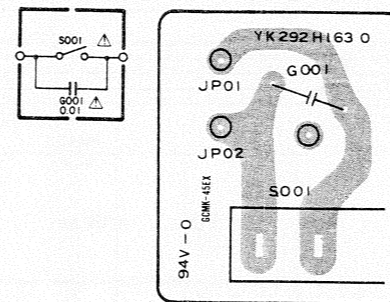

5.4 Headphone Jack Assembly (PW01)  
Schematic Diagram and Component Locations

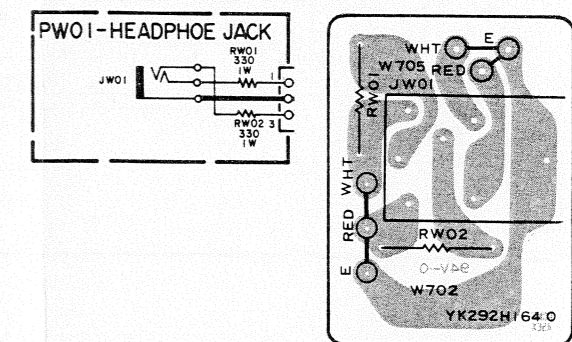



5.5 Main Amp. Assembly (P701) Schematic Diagram and Component Locations

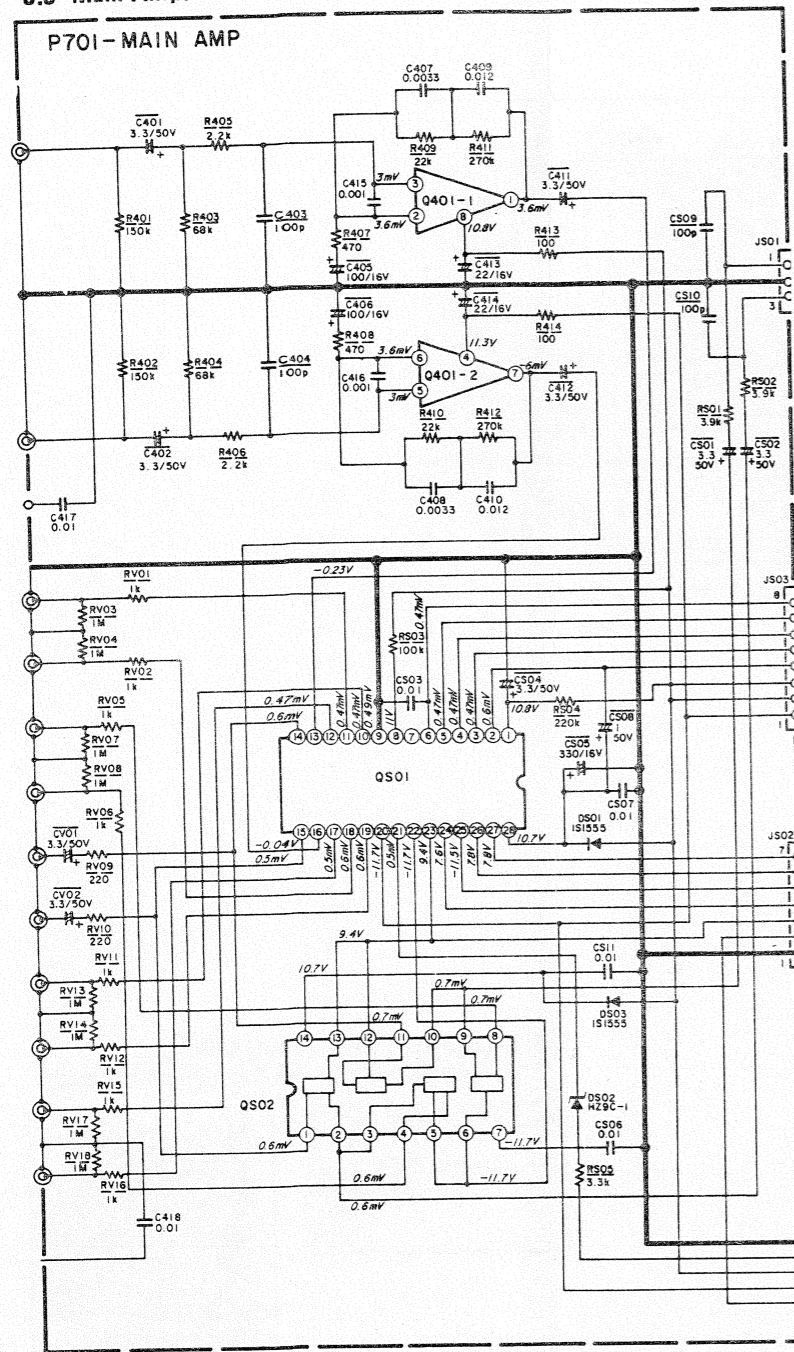

5.6 Speaker Lamp Assembly (PX01) Schematic Diagram and Component Locations

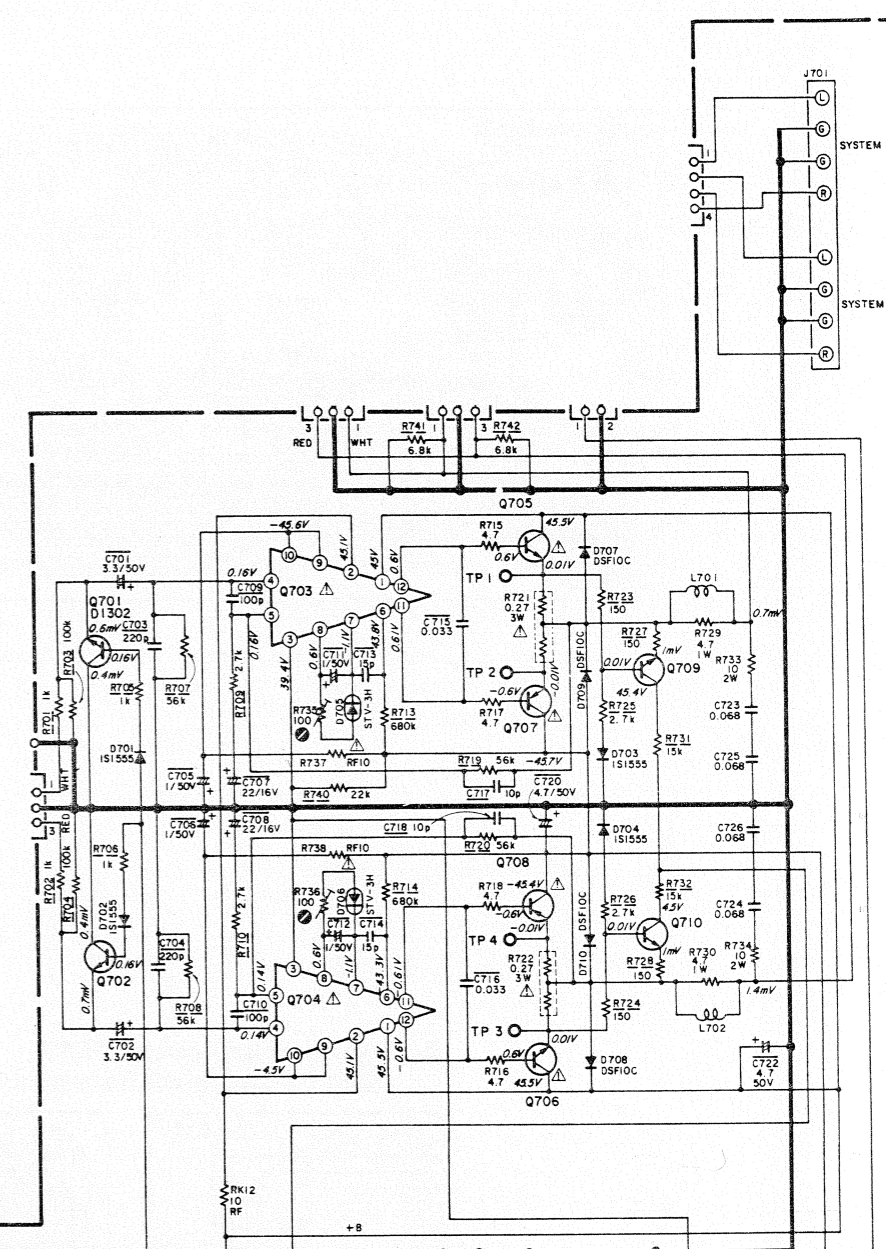
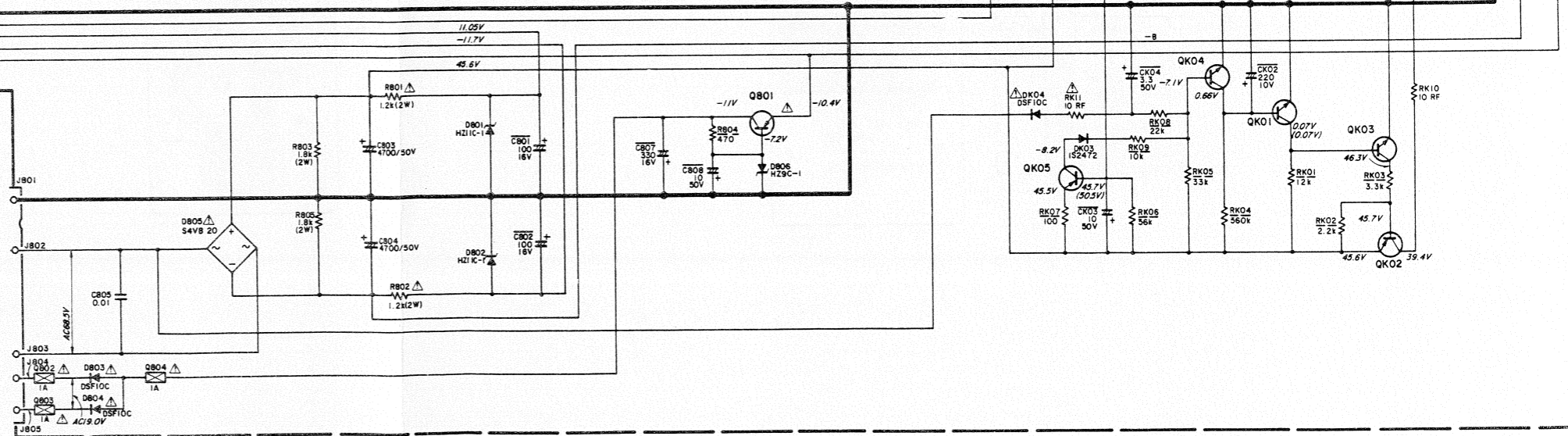
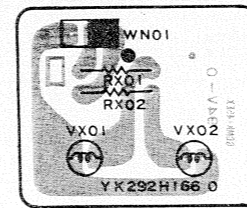
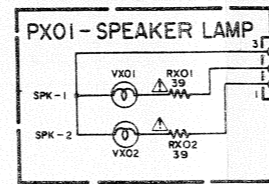







6. EXPLODED VIEW AND PARTS LIST

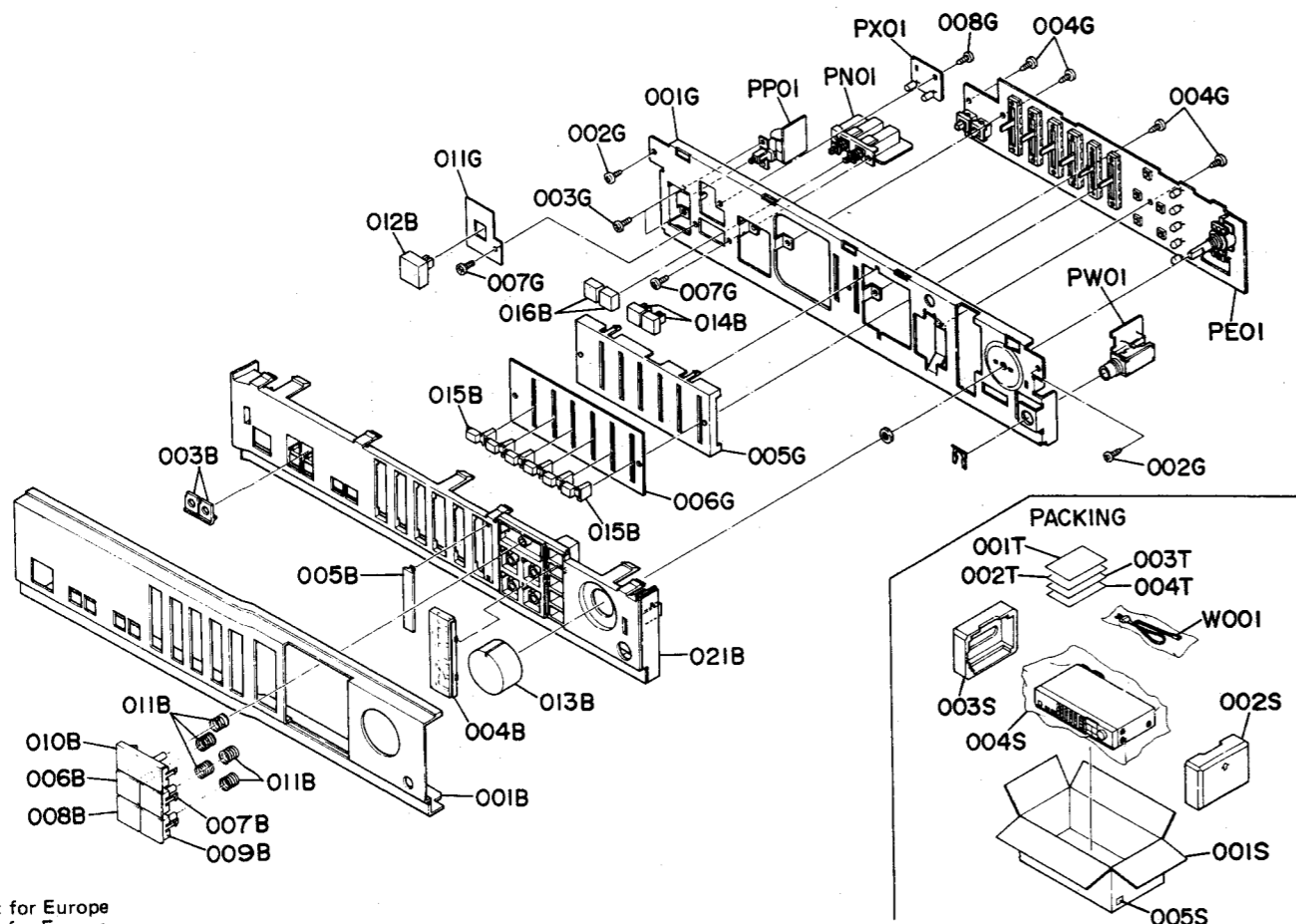

•(N): for Europe  
•(E): for Europe  
•(A): for Australia

REF. DESIG.	PART NO.	DESCRIPTION
A	292H248400	Front Panel Assembly
001B	292H248010	Front Panel
003B	158T355010	Lens, Speaker
004B	292H265010	Indicator, Function
005B	261H265110	Indicator, Balance
006B	261H270110	Button, Tuner
007B	261H270120	Button, Phono
008B	261H270130	Button, Video/AUX
009B	261H270140	Button, Tape Monitor
010B	261H270150	Button, CD
011B	261H115010	Spring, Button
021B	261H105510	Chassis, Front; K
012B	158T270010	Button, Power Switch
013B	261H154010	Knob, Volume
014B	262H270020	Button, Subsonic/Loudness
015B	261H154020	Knob, Balance EQ
016B	242H270020	Button, Speaker
001G	261H105010	Chassis, Front
002G	51280308B0	B.H. Tapped Screw B3 x 8
003G	51100306A0	B.H.M. Scree B3 x 6
004G	51280308B0	B.H. Tapped Screw B3 x 8
005G	261H053010	Cover, Tone
006G	292H265020	Indicator, Tone
007G	51100306A0	B.H.M. Screw B3 x 6
008G	51280308B0	B.H. Tapped Screw B3 x 8
011G	261H120010	Insulator, Power Switch [N]

REF. DESIG.	PART NO.	DESCRIPTION
001S	292H801010	Packing Case
002S	261H809010	Cushion, (R)
003S	261H809020	Cushion, (L)
004S	9014326150	Polyethylene Bag
005S	9526019060	Serial No. Card [N]
	9526019030	Serial No. Card [A]
001T	292H851310	User Manual
002T	292H851320	User Manual, Spec
003T	292H856010	Circuit Diagram [N]
004T	9631000090	Warranty Card [A]
Δ W001	ZC01805010	A.C. Power Cord [N]
Δ W001	ZC02006020	A.C. Power Cord [A]

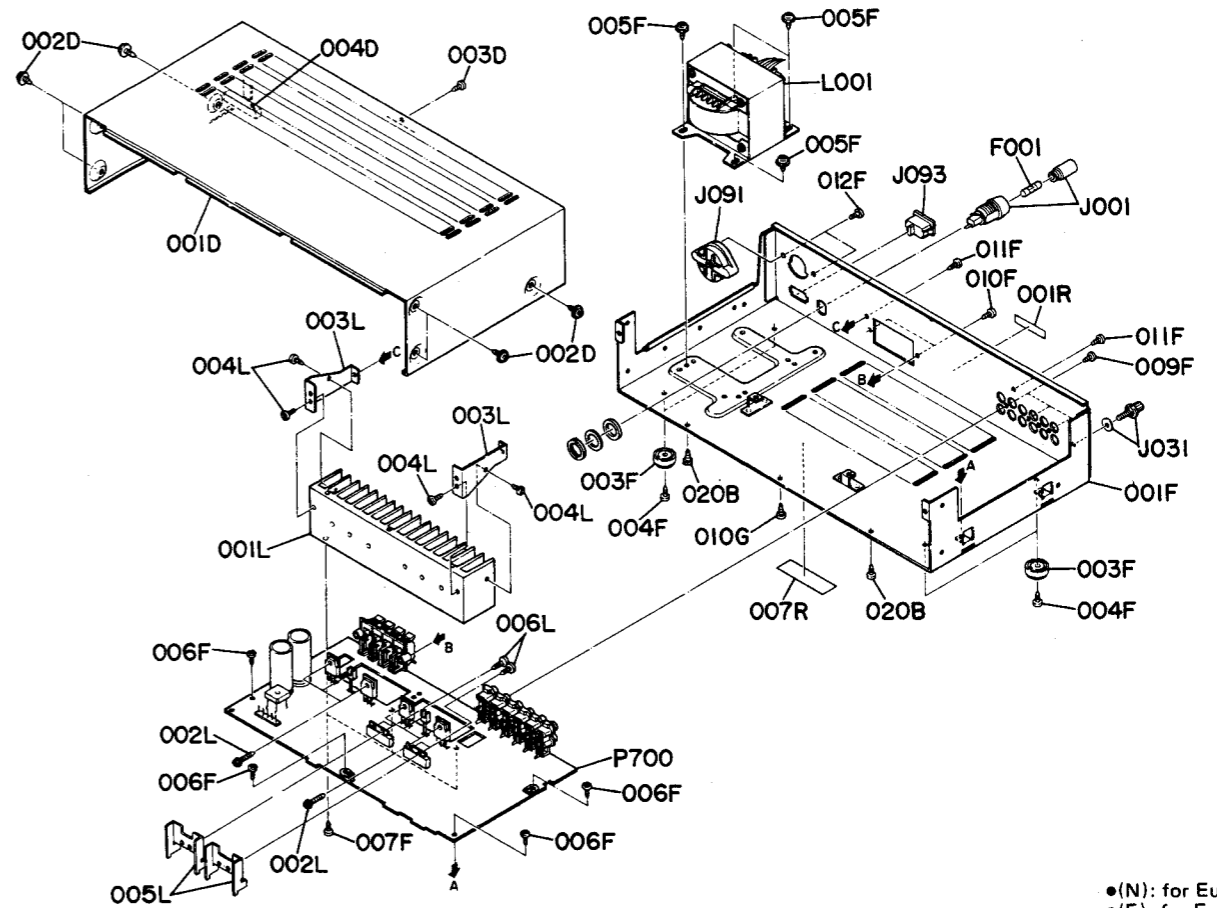

•(N): for Europe  
•(E): for Europe  
•(A): for Australia

REF. DESIG.	PART NO.	DESCRIPTION
020B	51280310B0	B.H. Tapped Screw B3 x 10
001D	261H257010	Lid, Top Cover
002D	51706009U0	Special Set Screw
003D	51280308B0	B.H. Tapped Screw B3 x 8
004D	261H056010	Buffer, Top Cover
001F	292H105020	Chassis, Main
003F	011T057010	Leg
004F	51280408B0	B.H. Tapped Screw B4 x 8
005F	52040408A0	H. Head Bolt, S.F. H4 x 8
006F	51280308B0	B.H. Tapped Screw B3 x 8
007F	51280308B0	B.H. Tapped Screw B3 x 8
009F	51280308B0	B.H. Tapped Screw B3 x 8
010F	51280308B0	B.H. Tapped Screw B3 x 8
011F	51280308B0	B.H. Tapped Screw B3 x 8
012F	51280308B0	B.H. Tapped Screw B3 x 8
010G	51280310B0	B.H. Tapped Screw B3 x 10

REF. DESIG.	PART NO.	DESCRIPTION
001L	261H267010	Heatsink, Main
002L	51780312B0	Fin Neck B.T. Screw B3 x 12
003L	261H160010	Bracket, Heatsink
004L	51280308B0	B.H. Tapped Screw B3 x 8
005L	262H267010	Heatsink, IC
006L	51280308B0	B.H. Tapped Screw B3 x 8
001R	2112265110	Indicator, Serial No.
007R	2911861110	Label
Δ F001	FS10125800	Fuse T1.25A 250V
Δ J001	YJ08000290	Jack, Fuse Holder
J031	YL03010250	Terminal, GND
Δ J091	BY05080050	Voltage Selector
Δ J093	YP04000580	Plug, AC Inlet
Δ L001	TS17629010	Power Transformer

## 7. ELECTRICAL PARTS LIST

•(N): for Europe  
 •(E): for Europe  
 •(A): for Australia

### ASSIGNMENT OF COMMON PARTS CODES.

#### RESISTOR

**R\*\*\*:** (1) GD05 --- 140, Carbon film fixed resistor,  $\pm 5\%$ , 1/4W  
**R\*\*\*:** (2) GD05 --- 160, Carbon film fixed resistor,  $\pm 5\%$ , 1/6W

① — Resistance value

#### Examples

① Resistance value  
 0.1 $\Omega$ ...001 10 $\Omega$ ...100 1k $\Omega$ ...102 100k $\Omega$ ...104  
 0.5 $\Omega$ ...005 18 $\Omega$ ...180 2.7k $\Omega$ ...272 680k $\Omega$ ...684  
 1 $\Omega$ ...010 100 $\Omega$ ...101 10k $\Omega$ ...103 1Mk $\Omega$ ...105  
 6.8 $\Omega$ ...068 390 $\Omega$ ...391 22k $\Omega$ ...223 4.7Mk $\Omega$ ...475

(Note) Please distinguish 1/4W from 1/6W by the shape of parts used actually.

#### C\*\*\*: CERAMIC CAP.

(1) DD1 --- 370, Ceramic condenser  
 Disc type  
 Temp. coeff. P350 ~ N1000, 50V

① ②  
 Capacity value  
 Tolerance

#### Examples

① Tolerance (Capacity deviation)  
 $\pm 0.25\text{pF}$ ...0  
 $\pm 0.5\text{pF}$ ...1  
 $\pm 5\%$ ...5

\* Tolerance of COMMON PARTS handled here are as follows:

0.5pF ~ 5pF... $\pm 0.25\text{pF}$   
 6pF ~ 10pF... $\pm 0.5\text{pF}$   
 12pF ~ 560pF... $\pm 5\%$

#### ② Capacity value

0.5pF...005 3pF...030 100pF...101  
 1pF...010 10pF...100 220pF...221  
 1.5pF...015 47pF...470 560pF...561

#### C\*\*\*: CERAMIC CAP.

(1) DK16 --- 300, High dielectric constant ceramic condenser  
 Disc type  
 Temp. chara. 2B4, 50V

①  
 Capacity value

#### Example

② Capacity value  
 100pF...101 1000pF...102 10000pF...103  
 470pF...471 2200pF...222

#### C\*\*\*: ELECTROLY CAP. ( $\neq$ ), FILM CAP. ( $\neq$ )

(1) EA --- 10, Electrolytic condenser  
 One-way lead type, Tolerance  $\pm 20\%$

① ②  
 Dielectric strength  
 Capacity value

#### Examples

① Capacity value  
 0.1 $\mu\text{F}$ ...104 4.7 $\mu\text{F}$ ...475 100 $\mu\text{F}$ ...107  
 0.33 $\mu\text{F}$ ...334 10 $\mu\text{F}$ ...106 330 $\mu\text{F}$ ...337  
 1 $\mu\text{F}$ ...105 22 $\mu\text{F}$ ...226 1100 $\mu\text{F}$ ...108  
 2200 $\mu\text{F}$ ...228

#### ② Working voltage

6.3V...006 25V...025  
 10V...010 35V...035  
 16V...016 50V...050

(2) DF15 --- 350, Plastic film condenser  
 One-way type, Mylar  $\pm 5\%$  50V

①  
 Capacity value

#### Examples

① Capacity value  
 0.001 $\mu\text{F}$  (1000pF)...102 0.1 $\mu\text{F}$ ...104  
 0.0018 $\mu\text{F}$ ...182 0.56 $\mu\text{F}$ ...564  
 0.01 $\mu\text{F}$ ...103 1 $\mu\text{F}$ ...105  
 0.015 $\mu\text{F}$ ...153

REF. DESIG.	PART NO.	DESCRIPTION
P701	YK292H1610 ZZ292H8610	<b>P701-MAIN AMP CIRCUIT BOARD</b> P.W. Board, Main Amp P.W. Board Assembly
		<b>P701-CAPACITORS</b>
C407	DF16332350	Film 3300pF $\pm 10\%$
C408	DF16332350	Film 3300pF $\pm 10\%$
C409	DF16123350	Film 0.012 $\mu\text{F}$ $\pm 10\%$
C410	DF16123350	Film 0.012 $\mu\text{F}$ $\pm 10\%$
C415	DF16182350	Film 1800pF $\pm 10\%$
C416	DF16182350	Film 1800pF $\pm 10\%$
C417	DK18103310	Ceramic 0.01 $\mu\text{F}$
C418	DK18103310	Ceramic 0.01 $\mu\text{F}$
C420	DK18103310	Ceramic 0.01 $\mu\text{F}$
C723	DF16683350	Film 0.068 $\mu\text{F}$ $\pm 10\%$
C724	DF16683350	Film 0.068 $\mu\text{F}$ $\pm 10\%$
C725	DF16683350	Film 0.068 $\mu\text{F}$ $\pm 10\%$
C726	DF16683350	Film 0.068 $\mu\text{F}$ $\pm 10\%$
C803	EB47805010	Elect 4700 $\mu\text{F}$ 50V
C804	EB47805010	Elect 4700 $\mu\text{F}$ 50V
C805	DK18103560	Ceramic 0.01 $\mu\text{F}$ 500V
CS03	DK18103310	Ceramic 0.01 $\mu\text{F}$
CS06	DK18103310	Ceramic 0.01 $\mu\text{F}$
CS07	DK18103310	Ceramic 0.01 $\mu\text{F}$
CS11	DK18103310	Ceramic 0.01 $\mu\text{F}$
		<b>P701-RESISTORS</b>
R715	GG05047140	4.7 $\Omega$ $\pm 5\%$ 1/4W
R716	GG05047140	4.7 $\Omega$ $\pm 5\%$ 1/4W
R717	GG05047140	4.7 $\Omega$ $\pm 5\%$ 1/4W
R718	GG05047140	4.7 $\Omega$ $\pm 5\%$ 1/4W
$\Delta$ R721	BW10000040	0.27 $\Omega$ 3W, Composit
$\Delta$ R722	BW10000040	0.27 $\Omega$ 3W, Composit
R729	GA05047010	4.7 $\Omega$ $\pm 5\%$ 1W
R730	GA05047010	4.7 $\Omega$ $\pm 5\%$ 1W
R733	GA05100020	10 $\Omega$ $\pm 5\%$ 2W
R734	GA05100020	10 $\Omega$ $\pm 5\%$ 2W
R735	RA01010600	100 $\Omega$ (B), Trimming
R736	RA01010600	100 $\Omega$ (B), Trimming
$\Delta$ R737	NH05100140	10 $\Omega$ $\pm 5\%$ 1/4W, Fusible
$\Delta$ R738	NH05100140	10 $\Omega$ $\pm 5\%$ 1/4W, Fusible
$\Delta$ R801	GA05122020	1.2K $\Omega$ $\pm 5\%$ 2W
$\Delta$ R802	GA05122020	1.2K $\Omega$ $\pm 5\%$ 2W
R803	GA05182020	1.8K $\Omega$ $\pm 5\%$ 2W
R805	GA05182020	1.8K $\Omega$ $\pm 5\%$ 2W
$\Delta$ RK10	NH05100140	10 $\Omega$ $\pm 5\%$ 1/4W, Fusible
$\Delta$ RK11	NH05100140	10 $\Omega$ $\pm 5\%$ 1/4W, Fusible
$\Delta$ RK12	NH05100140	10 $\Omega$ $\pm 5\%$ 1/4W, Fusible
		<b>P701-SEMICONDUCTORS</b>
D701	HD20001000	Diode 1S1555
D702	HD20001000	Diode 1S1555
D703	HD20001000	Diode 1S1555
D704	HD20001000	Diode 1S1555
D705	HV00009080	Varistor STV3H(O, Y)
D706	HV00009080	Varistor STV3H(O, Y)
D707	HD20022030	Diode DSF10C
D708	HD20022030	Diode DSF10C
D709	HD20022030	Diode DSF10C
D710	HD20022030	Diode DSF10C

M4289

•(N): for Europe  
 •(E): for Europe  
 •(A): for Australia

REF. DESIG.	PART NO.	DESCRIPTION
D801	HD30038010	Zener HZ11C1L
D802	HD30038010	Zener HZ11C1L
△ D803	HD20022030	Diode DSF10C
△ D804	HD20022030	Diode DSF10C
△ D805	HD20008290	Diode S4VB20
D806	HD30045010	Zener HZ9C1L
DK03	HD20002210	Diode 1S2472
△ DK04	HD20022030	Diode DSF10C
DS01	HD20001000	Diode 1S1555
DS02	HD30045010	Zener HZ9C1L
DS03	HD20001000	Diode 1S1555
Q401	HC10008090	IC 4558DD
Q701	HT413022B0	Transistor 2SD1302(S, T)
Q702	HT413022B0	Transistor 2SD1302(S, T)
△ Q703	HC10097060	IC MPC1270H
△ Q704	HC10097060	IC MPC1270H
△ Q705	HT331812A0	Transistor 2SC3181(R, O)
△ Q706	HT331812A0	Transistor 2SC3181(R, O)
△ Q707	HT112642A0	Transistor 2SA1264(R, O)
△ Q708	HT112642A0	Transistor 2SA1264(R, O)
Q709	HT327851F0	Transistor 2SC2785(J, H)
Q710	HT327851F0	Transistor 2SC2785(J, H)
△ Q801	HT206472F0	Transistor 2SB647(C, D)
△ Q802	FU10215010	Protector Unit ICP-1A
△ Q803	FU10215010	Protector Unit ICP-1A
△ Q804	FU10215010	Protector Unit ICP-1A
QK01	HT327852B0	Transistor 2SC2785(J, H)
QK02	HT109331Q0	Transistor 2SA933SP(Q)
QK03	HT327852B0	Transistor 2SC2785(J, H)
QK04	HT327852B0	Transistor 2SC2785(J, H)
QK05	HT109331Q0	Transistor 2SA933SP(Q)
QS01	HC10110030	IC LC7815H
QS02	HC406603C0	IC LC4066B-H
<b>P701-MISCELLANEOUS</b>		
J401	YL01010110	Terminal, Earth
J701	YT03080020	Terminal, Speaker
J703	YL01010110	Terminal, Earth
JV01	YT02040500	Terminal, RCA Jack; 4P
JV02	YT02040500	Terminal, RCA Jack; 4P
JV03	YT02040500	Terminal, RCA Jack; 4P
L701	LL23905120	Coil, 1μH
L702	LL23905120	Coil, 1μH
W701	YU02220260	Jumper Lead, 2P
W703	YU03140260	Jumper Lead, 3P
W704	YU04140260	Jumper Lead, 4P
<b>PE01-VOLUME CIRCUIT BOARD</b>		
PE01	YK292H1620	P.W. Board, Volume
	ZZ292H8620	P.W. Board Assembly

REF. DESIG.	PART NO.	DESCRIPTION
<b>PE01-RESISTORS</b>		
RE01	RM01040840	100KΩ(B), Variable; Main
RE02	RX02040080	200KΩ(W), Variable; Balance
RE23	RS02540150	250KΩ(W), Variable; GEQ VR
RE24	RS02540150	250KΩ(W), Variable; GEQ VR
RE25	RS02540150	250KΩ(W), Variable; GEQ VR
RE26	RS02540150	250KΩ(W), Variable; GEQ VR
RE27	RS02540150	250KΩ(W), Variable; GEQ VR
△ RY11	GG05390140	39Ω ±5% ¼W
△ RY12	GG05390140	39Ω ±5% ¼W
<b>PE01-SEMICONDUCTORS</b>		
QE01	HC10021090	IC 4560D-D
QE02	HC10052210	IC BA3812L
QE03	HC10052210	IC BA3812L
QY01	HT109331Q0	Transistor 2SA933SP(Q)
QY02	HT109331Q0	Transistor 2SA933SP(Q)
QY03	HT109331Q0	Transistor 2SA933SP(Q)
QY04	HT109331Q0	Transistor 2SA933SP(Q)
QY05	HT109331Q0	Transistor 2SA933SP(Q)
<b>PE01-MISCELLANEOUS</b>		
SE01	SP02011090	Push Switch, Loudness ON/OFF
SE02	SP02011090	Push Switch, Filter ON/OFF
SY01	SP01010840	Push Switch, Tact; CD
SY02	SP01010840	Push Switch, Tact; Phono
SY03	SP01010840	Push Switch, Tact; Tuner
SY04	SP01010840	Push Switch, Tact; Video/AUX
SY05	SP01010840	Push Switch, Tact; Tape Monitor
VY01	IN10080620	Lamp 50mA 8V, Tuner
VY02	IN10080620	Lamp 50mA 8V, CD
VY03	IN10080620	Lamp 50mA 8V, Video/AUX
VY04	IN10080620	Lamp 50mA 8V, Phono
VY05	IN10080620	Lamp 50mA 8V, Tape Monitor
WE01	YU03160260	Jumper Lead, 3P
WY02	YU07160260	Jumper Lead, 7P
WY03	YU08160260	Jumper Lead, 8P

- (N): for Europe
- (E): for Europe
- (A): for Australia

REF. DESIG.	PART NO.	DESCRIPTION
PN01	YK292H1650 ZZ292H8650	<b>PN01-SPEAKER SWITCH CIRCUIT BOARD</b> P.W. Board, Speaker Switch P.W. Board Assembly
SN01	SP04020440	Push Switch, Speaker
WN01	YU03120260	Jumper Lead, 3P
PP01	YK292H1630 ZZ292H8630	<b>PP01-POWER SWITCH CIRCUIT BOARD</b> P.W. Board, Power Switch P.W. Board Assembly
△ G001	DK18103840	Ceramic Cap. 0.01μF 250V
△ S001	SP01010650	Push Switch, Power
PW01	YK292H1640 ZZ292H8640	<b>PW01-HEADPHONE JACK CIRCUIT BOARD</b> P.W. Board, Headphone Jack P.W. Board Assembly
RW01	GA05331010	Resistor 330Ω ±5% 1W
RW02	GA05331010	Resistor 330Ω ±5% 1W
JW01	YJ01001790	Jack, Headphone
PX01	YK292H1660 ZZ292H8660	<b>PX01-SPEAKER LAMP CIRCUIT BOARD</b> P.W. Board, Speaker Lamp P.W. Board Assembly
△ RX01	GG05390140	Resistor 39Ω ±5% ¼W
△ RX02	GG05390140	Resistor 39Ω ±5% ¼W
VX01	IN10080620	Lamp 50mA 8V, Speaker 1
VX02	IN10080620	Lamp 50mA 8V, Speaker 2

(W01-99)	Assembly and Wiring
(T01-99)	Adjustment
(X01-00)	Correction

**NOTE ON SAFETY :**

Symbol △ Fire or electrical shock hazard. Only original parts should be used to replace any part marked with symbol △. Any other component substitution (other than original type), may increase risk of fire or electrical shock hazard.

## 8. TECHNICAL SPECIFICATIONS

### AUDIO SECTION

#### POWER OUTPUT PER CHANNEL

DIN 4 OHMS	50 W
RMS 4 OHMS	40 W
DIN 8 OHMS	50 W
RMS 8 OHMS	40 W
TOTAL HARMONIC DISTORTION AT RMS 8 OHMS	0.05%
I.M. DISTORTION	0.05%
DAMPING FACTOR 8 OHMS (1 kHz)	55

#### MM CARTRIDGE INPUT

Frequency Response (RIAA) 20 Hz – 20 kHz	±0.5 dB
Signal-to-Noise Ratio	72 dB
Input Impedance	47 k ohms
Input Capacitance	100 pF
Input Sensitivity	2.5 mV

#### AUX. INPUT

Input Impedance	25 k ohms
Input Sensitivity	150 mV
Frequency Response (±2 dB)	10 Hz – 50 kHz
Signal-to-Noise Ratio	92 dB

#### OUTPUT VOLTAGE

Tape Out (Input 7.75 mV)	417 mV
--------------------------	--------

#### OUTPUT IMPEDANCE

Tape Out	300 ohms
----------	----------

#### GENERAL

Power Requirements	110/120/220/240V AC, 50/60 Hz
Power Consumption at Rated Output, both Channels Operating	200 W
Dimensions	
Panel Width	416 mm
Panel Height	85 mm
Depth	225 mm
Weight	
Unit Alone	5.0 kg

Specifications and appearance are subject to change for modification without notice.



9. SCHEMATIC DIAGRAM

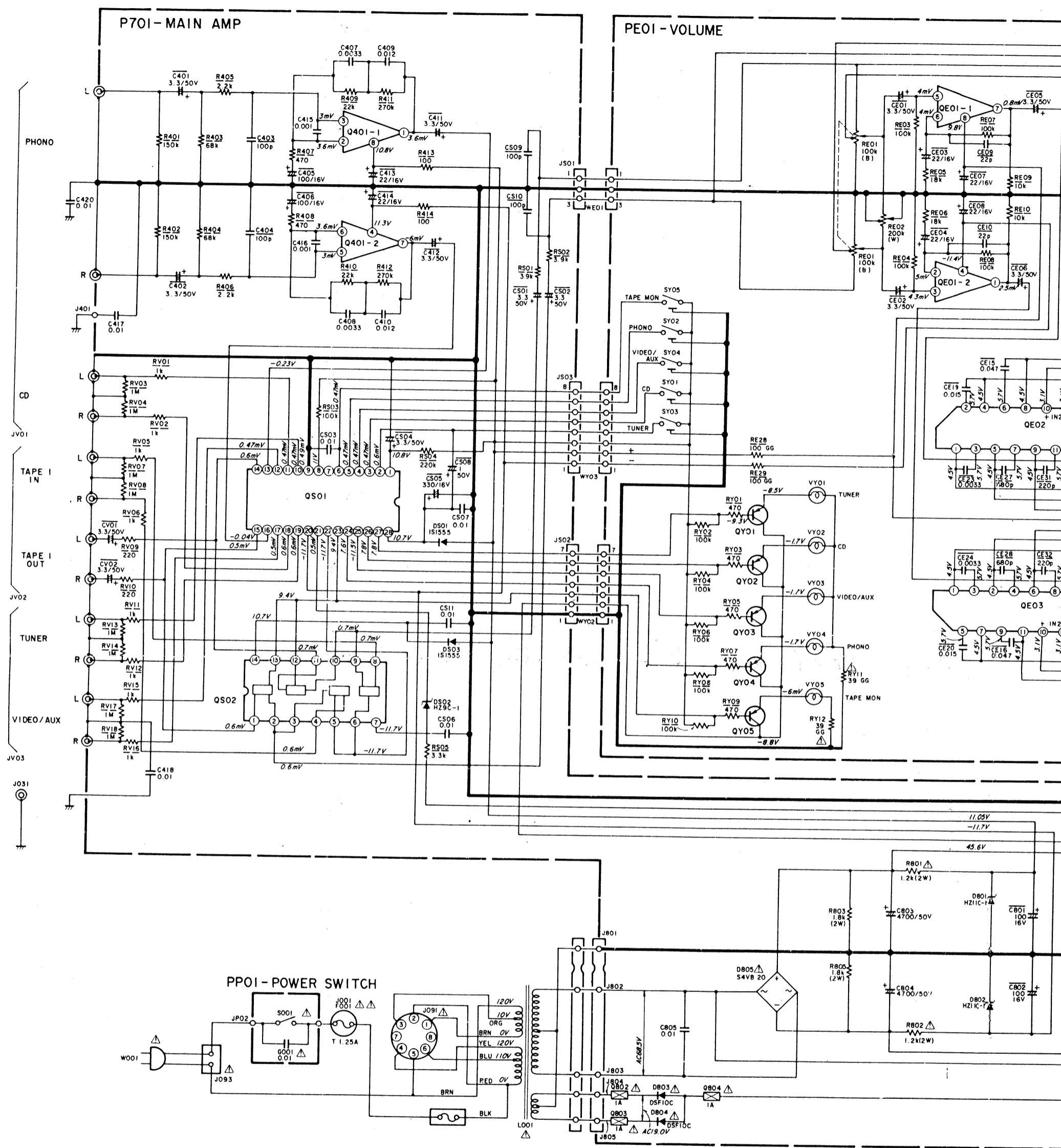

- |      |            |                     |      |            |                          |
|------|------------|---------------------|------|------------|--------------------------|
| F001 | FS10125800 | FUSE 1.25A          | VX01 | IN10080620 | LAMP 8V 50mA             |
| G001 | DK18103840 | CERAMIC 0.01μF      | VX02 | IN10080620 | LAMP 8V 50mA             |
| J001 | YJ08000290 | JACK FUSE HOLDER    | JW01 | YT02040500 | TERMINAL RCA JACK        |
| J091 | BY05080050 | VOLTAGE SELECTOR    | JV03 |            |                          |
| J093 | YP04000580 | PLUG AC INLET       | VY01 | IN10080620 | LAMP 8V 50mA             |
| L001 | TS17629010 | POWER TRANSFORMER   | VY05 |            |                          |
| S001 | SP01010650 | PUSH SWITCH POWER   | RE01 | RM01040840 | VARIABLE MAIN VOL. 100kΩ |
| W001 | ZC02006020 | AC POWER CORD (A)   | RE02 | RX02040080 | VARIABLE BALANCE 200kΩ   |
| W001 | ZC01805010 | AC POWER CORD (N)   | RE23 |            |                          |
| JW01 | YJ01001790 | JACK HEADPHONE      |      | RS02540150 | VARIABLE G. EQ. 250kΩ    |
| J701 | YT03080020 | TERMINAL SPEAKER    | RE27 |            |                          |
| L701 | LL23905120 | COIL 1mH            | SE01 | SP02011090 | PUSH SWITCH LOUDNESS     |
| L702 | LL23905120 | COIL 1mH            | SE02 | SP02011090 | PUSH SWITCH LOW FILTER   |
| R735 | RA01010600 | TRIMMING 100Ω       |      |            |                          |
| R736 | RA01010600 | TRIMMING 100Ω       |      |            |                          |
| SN01 | SP04020440 | PUSH SWITCH SPEAKER |      |            |                          |

**NOTE ON SAFETY :**  
 Symbol  $\Delta$  Fire or electrical shock hazard. Only original parts should be used to replace any part marked with symbol  $\Delta$ . Any other component substitution (other than original type), may increase risk of fire or electrical shock hazard.

Components and wiring are subject to c

I - VOLUME

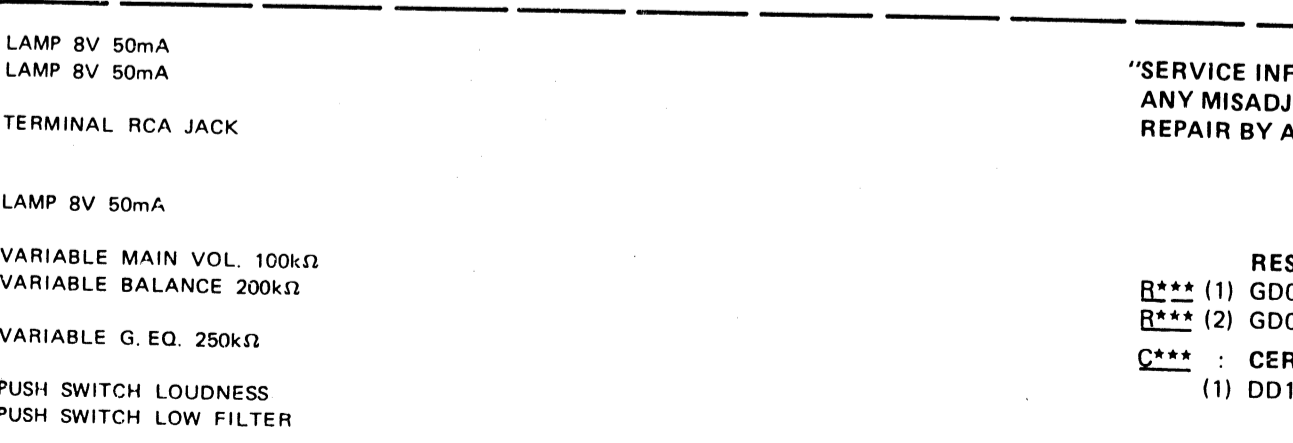
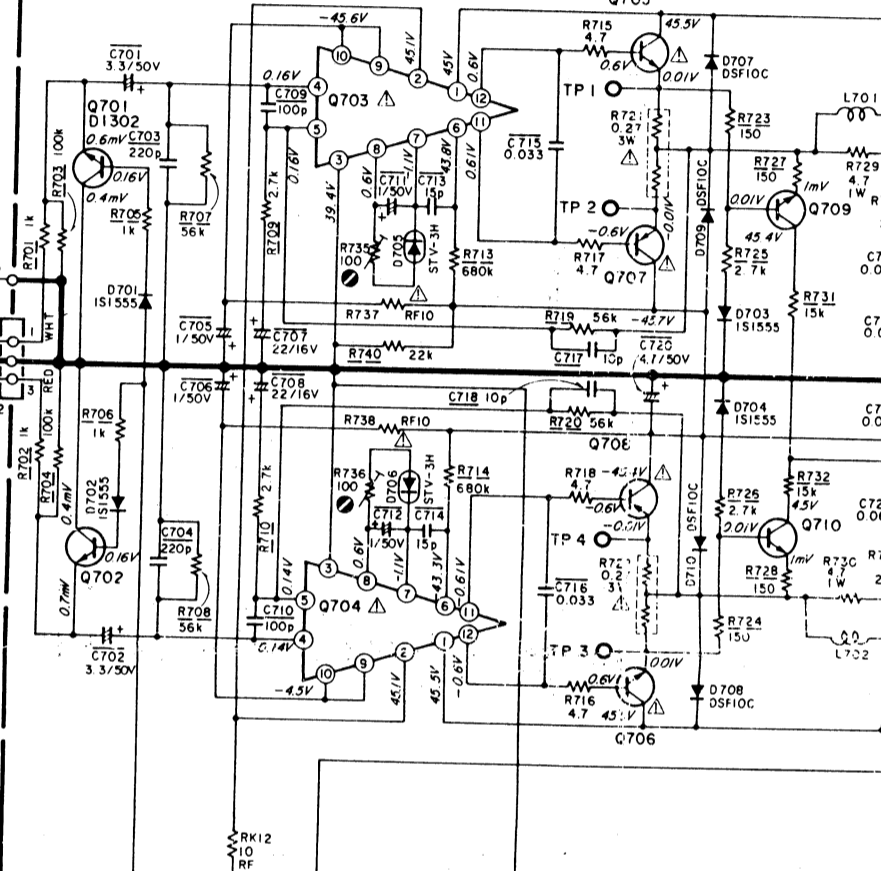
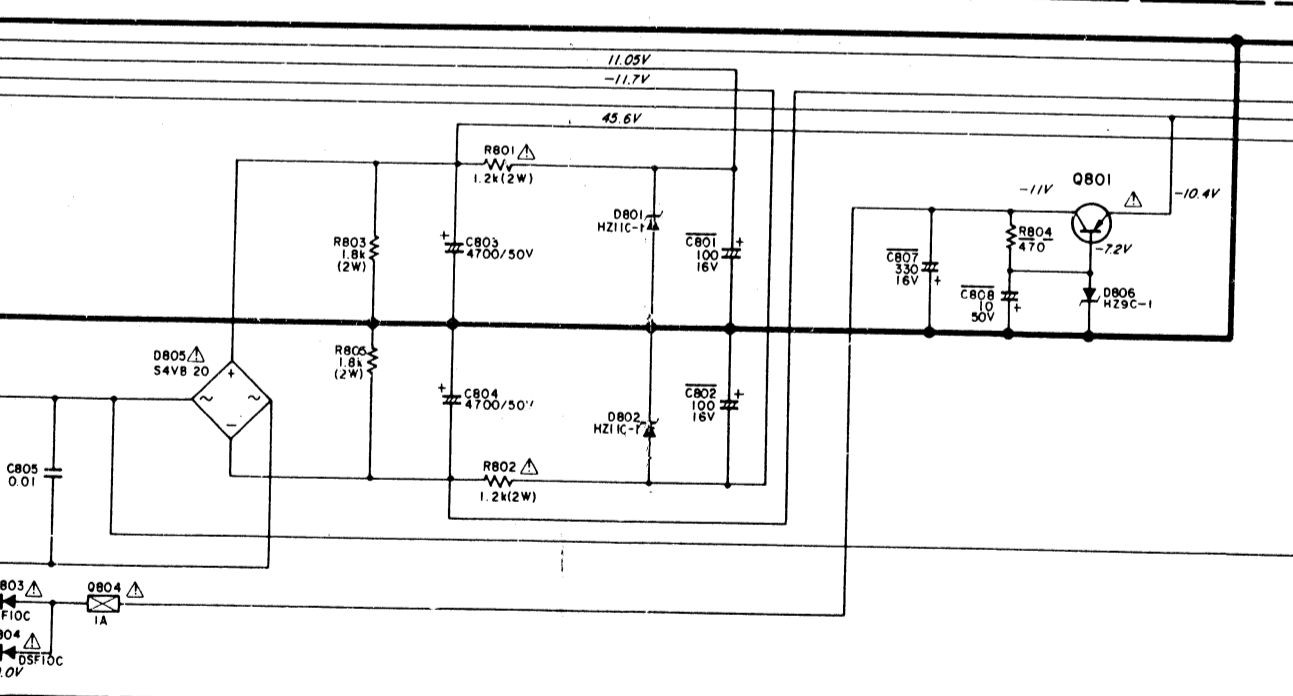
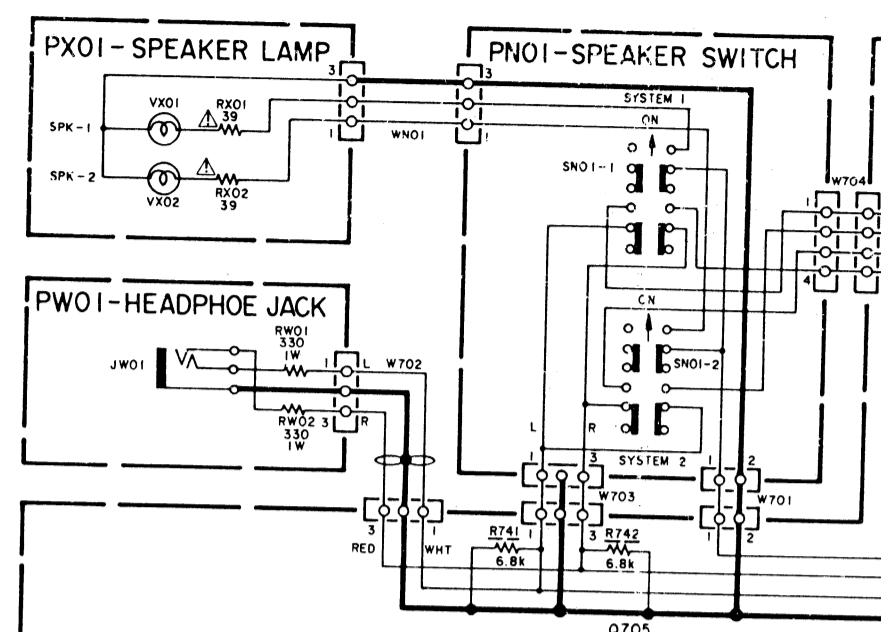
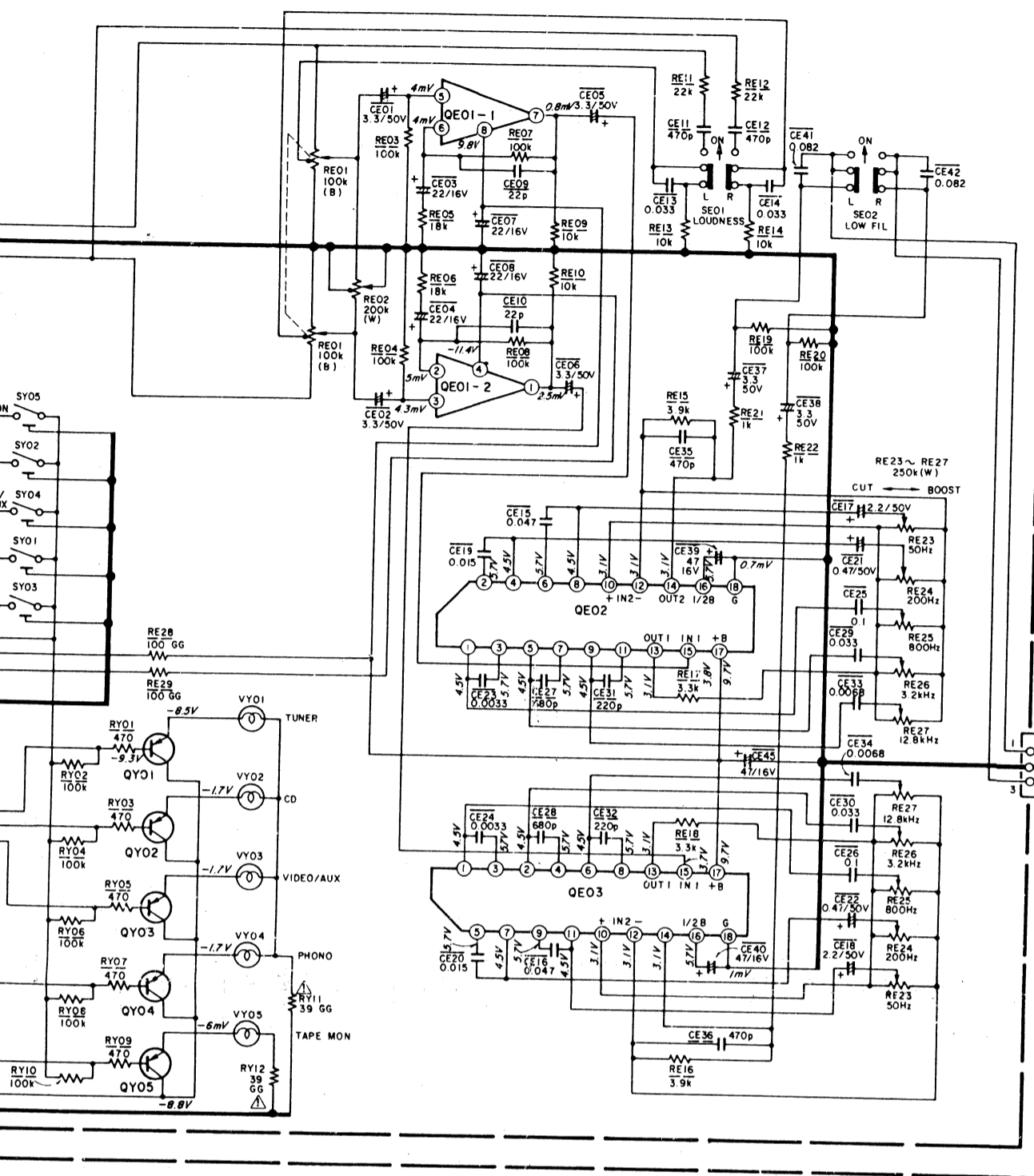

- LAMP 8V 50mA
- LAMP 8V 50mA
- TERMINAL RCA JACK
- LAMP 8V 50mA
- VARIABLE MAIN VOL. 100kΩ
- VARIABLE BALANCE 200kΩ
- VARIABLE G. EQ. 250kΩ
- PUSH SWITCH LOUDNESS
- PUSH SWITCH LOW FILTER

"SERVICE INFORMATION IS FOR USE BY QUALIFIED PERSONNEL ONLY - ANY MISADJUSTMENT OR MISALIGNMENT MAY BE TREATED AS A NON-WARRANTY REPAIR BY ANY MARANTZ SERVICE CENTRE -"

Kind of Common Parts

- RESISTOR**
- R\*\*\* (1) GD05 --- 140, Carbon film fixed resistor, ±5% 1/4W
  - R\*\*\* (2) GD05 --- 160, Carbon film fixed resistor, ±5% 1/6W
- CERAMIC CAP.**
- C\*\*\* (1) DD1 ---- 370, Ceramic condenser, disc type (titan condenser) Temp. coeff. P350 ~ N1000 50V
  - C\*\*\* (2) DK16 --- 300, High dielectric constant ceramic condenser, disc type (titan variable) Temp. chara. 2B4 50V
- ELECTROLYTIC CAP.**
- C\*\*\* (1) EA ----- 10
  - C\*\*\* (2) DF15 --- 350

\* In case of ordering the parts number of 10 for COMMON PARTS CODE

Components and wiring are subject to change for modification without notice.

# Model PM251

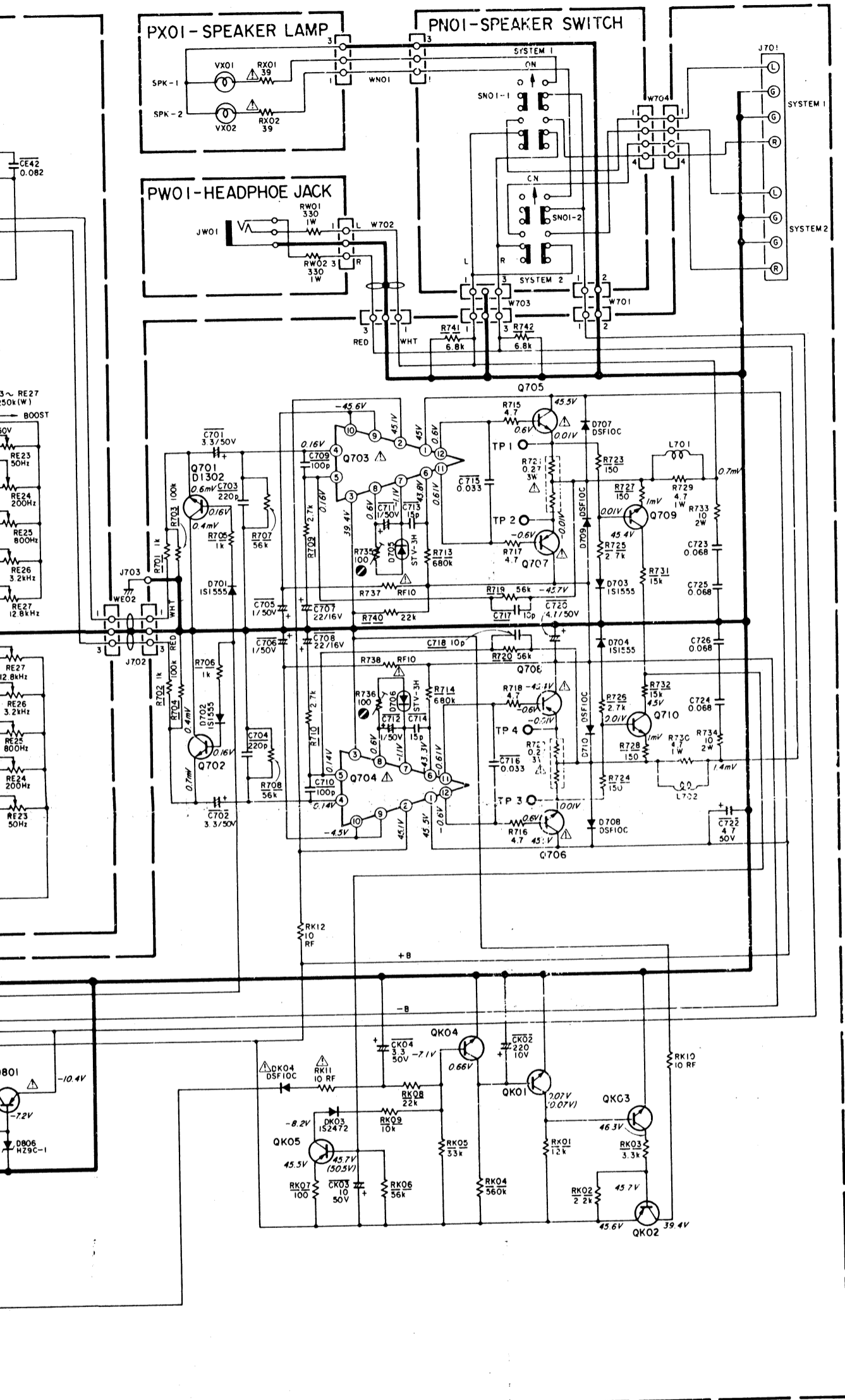

Q401  
HC10008090  
4558DD

Q701, Q702  
HT413022B0  
2SD1302(S, T)

Q703, Q704  
HC10097060  
μPC-1270H

Q705, Q706  
HT331812A0  
2SC3181(R, O)

Q707, Q708  
HT112642A0  
2SA1264(R, O)

Q709, Q710  
HT327851F0  
2SC2785(J, H)

Q801  
HT206472F0  
2SB647(C, D)

Q802, Q803, Q804  
FU10215010  
ICP 1A

QE01  
HC10021090  
4560D-D

QE02, QE03  
HC10052210  
BA3812L

QK01, QK03, QK04  
HT327852B0  
2SC2785(J, H)

QK02, QK05,  
QY01~QY05  
HT103331Q0  
2SA933SP(Q)

QS01  
HC10110030  
LC7815H

QS02  
HC406603C0  
LC4066B-H

D701~D704  
DS01, DS03  
HD20001000  
1S1555

D705, D706  
HV00009080

D803, D804, DK04  
D707~D710  
HD20022030  
DSF-10C

D801, D802  
HD30038010  
HZ11C-1L

D805  
HD20008290  
S4VB-20

D806, DS02  
HD30045010  
HZ9C-1L

DK03  
HD20002210  
1S2472

"SERVICE INFORMATION IS FOR USE BY QUALIFIED PERSONNEL ONLY -  
ANY MISADJUSTMENT OR MISALIGNMENT MAY BE TREATED AS A NON-WARRANTY  
REPAIR BY ANY MARANTZ SERVICE CENTRE -"

## Kind of Common Parts

### RESISTOR

R\*\*\* (1) GD05 --- 140, Carbon film fixed resistor, ±5% 1/4W  
R\*\*\* (2) GD05 --- 160, Carbon film fixed resistor, ±5% 1/6W

### C\*\*\* : CERAMIC CAP.

(1) DD1 --- 370, Ceramic condenser,  
disc type (titan condenser)  
Temp. coeff. P350 ~ N1000 50V

### C\*\*\* : CERAMIC CAP.

(1) DK16 --- 300, High dielectric constant ceramic condenser,  
disc type (titan variable)  
Temp. chara. 2B4 50V

### C\*\*\* : ELECTROLY CAP. (≡) / FILM CAP. (≡)

(1) EA --- 10, Electrolytic condenser,  
one-way lead type, tolerance ±20%  
(2) DF15 --- 350, Plastic film condenser,  
one-way type, Mylar, ±5% 50V

\* In case of ordering the common parts, please establish the correct  
parts number of 10 figures by the procedure "ASSIGNMENT OF  
COMMON PARTS CODES"