

SERV. 31 895

Service Manual

74 PM42/00B/01B/02B/05B/07B

Stereo amplifier

This service manual explains them by extracting the different specifications from those of the model PM-42, based on the model PM-40. For both electrical and mechanical information on the after-sales service which is not stated, all information is described in the model PM-40 service manual (Code-number is 4822 725 50913). The dispatch of the parts for after-sales service has to be referred to this service manual, with first priority. For this reason, please use this service manual with referring the model PM-40 service manual, without fail.

marantz®

model PM-42

First issue: 1992
4822 725 50998

Different Parts between model PM-40 and PM-42

PAGE	REF. DESIG.	PM-40	PM-42	DESCRIPTION
14	001B	4822 425 40177	4822 425 40183	Front Panel Assembly
	013B	4822 410 60395	4822 410 60902	
	005G	4822 462 41477	4822 462 41932	Leg
	001T	4822 736 20695	4822 736 21419	User Manual
	▲ L001	4822 146 21552	4822 146 21672	Power Transformer /00B/02B
16	CW03	—	4822 122 32486	Ceramic 0.01μF +80% -20%
	SS01	4822 276 12197	4822 276 12957	Push Switch
	LV01	4822 280 20195	4822 280 20501	Relay MR62-245R
17	RY06	4822 111 50474	4822 053 10331	Resistor 330Ω ±5% 1W
	C417	4822 124 90358	4822 124 90357	Elect 2.2μF 50V
	C418	4822 124 90358	4822 124 90357	Elect 2.2μF 50V
	C419	4822 124 90365	4822 124 90051	Elect 220μF 25V
	C420	4822 124 90365	4822 124 90051	Elect 220μF 25V
	R407	?		
	R410	4822 116 53691	4822 050 24642	Resistor 4.64KΩ ±1% 1/6W
	R431	4822 116 52892	4822 050 21021	Resistor 100Ω ±5% 1/4W
	R432	4822 116 52892	4822 050 21021	Resistor 100Ω ±5% 1/4W
	R434	4822 116 53479	4822 050 22209	Resistor 22Ω ±5% 1/4W
R441	4822 116 53691	4822 050 24642	Resistor 4.64KΩ ±1% 1/6W	
R442	4822 116 53691	4822 050 24642	Resistor 4.64KΩ ±1% 1/6W	
C701	4822 124 90362	4822 124 23082	Elect 10μF 50V	
C707	4822 121 51037	4822 121 50416	Film 150pF ±5%	
			/00B/01B/05B/07B	
		4822 126 11069	Ceramic 150pF /02B	
C708	4822 121 51037	4822 121 50416	Film 150pF ±5%	
			/00B/01B/05B/07B	
		4822 126 11069	Ceramic 150pF /02B	
C753	4822 121 43126	4822 121 50548	Film 120pF ±5%	
C754	4822 121 43126	4822 121 50548	Film 120pF ±5%	
C755	4822 121 43126	4822 121 50548	Film 120pF ±5%	
C756	4822 121 43126	4822 121 50548	Film 120pF ±5%	
14	▲ F002	4822 253 30027	4822 070 33152	Fuse T3.15A 250V

PAGE	REF. DESIG.	PM-40	PM-42	DESCRIPTION
18	RN01	4822 111 91257	4822 052 10102	Resistor 1KΩ ±5% 1/6W
	RN02	4822 111 91257	4822 052 10102	Resistor 1KΩ ±5% 1/6W
	R732	4822 116 60346	4822 053 10222	Resistor 2.2KΩ ±5% 1W
	R757			
	?	4822 111 91285	4822 052 10101	Resistor 100Ω ±5% 1/6W
	R760			
	R761	4822 111 91257	4822 052 10102	Resistor 1KΩ ±5% 1/6W
	R762	4822 111 91257	4822 052 10102	Resistor 1KΩ ±5% 1/6W
	R763	4822 111 50474	4822 053 10331	Resistor 330Ω ±5% 1W
	R764	4822 111 50474	4822 053 10331	Resistor 330Ω ±5% 1W
	▲ R765	4822 116 52348	4822 050 22208	Resistor 2.2Ω ±5% 1/4W
	▲ R766	4822 111 52348	4833 050 22208	Resistor 2.2Ω ±5% 1/4W
	R769	4822 116 52849	4822 050 22201	Resistor 220Ω ±5% 1/4W
	R770	4822 116 52849	4822 050 22201	Resistor 220Ω ±5% 1/4W
	R771	4822 111 90726	4822 053 11109	Resistor 10Ω ±5% 2W
	R772	4822 111 90726	4822 053 11109	Resistor 10Ω ±5% 2W
	▲ R773	4822 116 52348	4822 050 22208	Resistor 2.2Ω ±5% 1/4W
	▲ R774	4822 116 52348	4822 050 22208	Resistor 2.2Ω ±5% 1/4W
	R805	4822 111 91423	4822 052 10122	Resistor 1.2KΩ ±5% 1/4W
	R806	4822 111 91423	4822 052 10122	Resistor 1.2KΩ ±5% 1/4W
R810	4822 116 60338	4822 053 11151	Resistor 150Ω ±5% 2W	
L751	4822 157 51739	4822 157 63085	Coil Speaker	
L752	4822 157 51739	4822 157 63085	Coil Speaker	
C901	—	4822 122 32486	Ceramic 0.01μF 50V /02B	

SCHEMATIC DIAGRAM

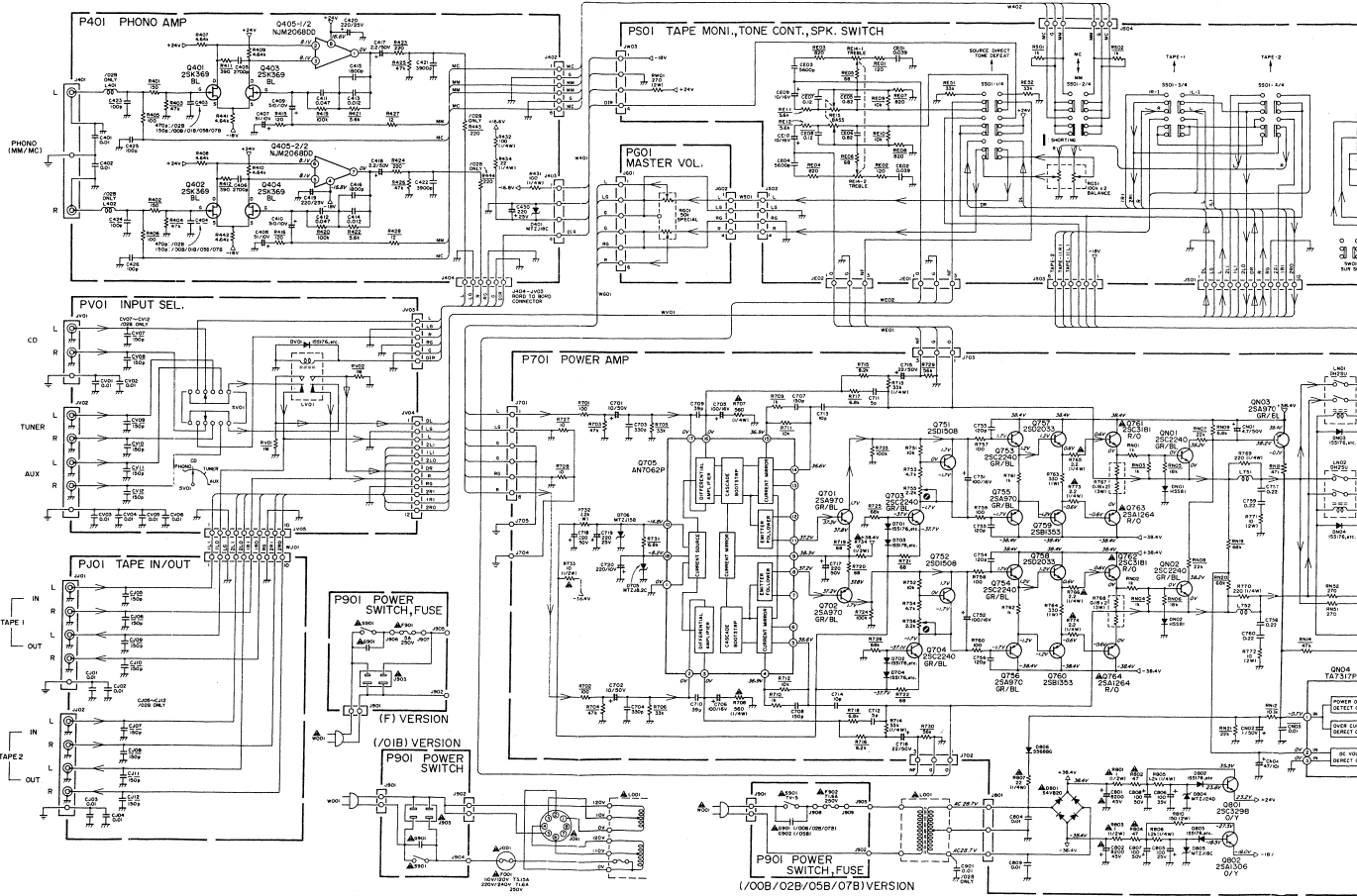

NOTE ON SAFETY :
 Symbol ▲ Fire or electrical shock hazard. Only original parts should be used to replace any part marked with symbol ▲. Any other component substitution [other than original type], may increase risk of fire or electrical shock hazard.

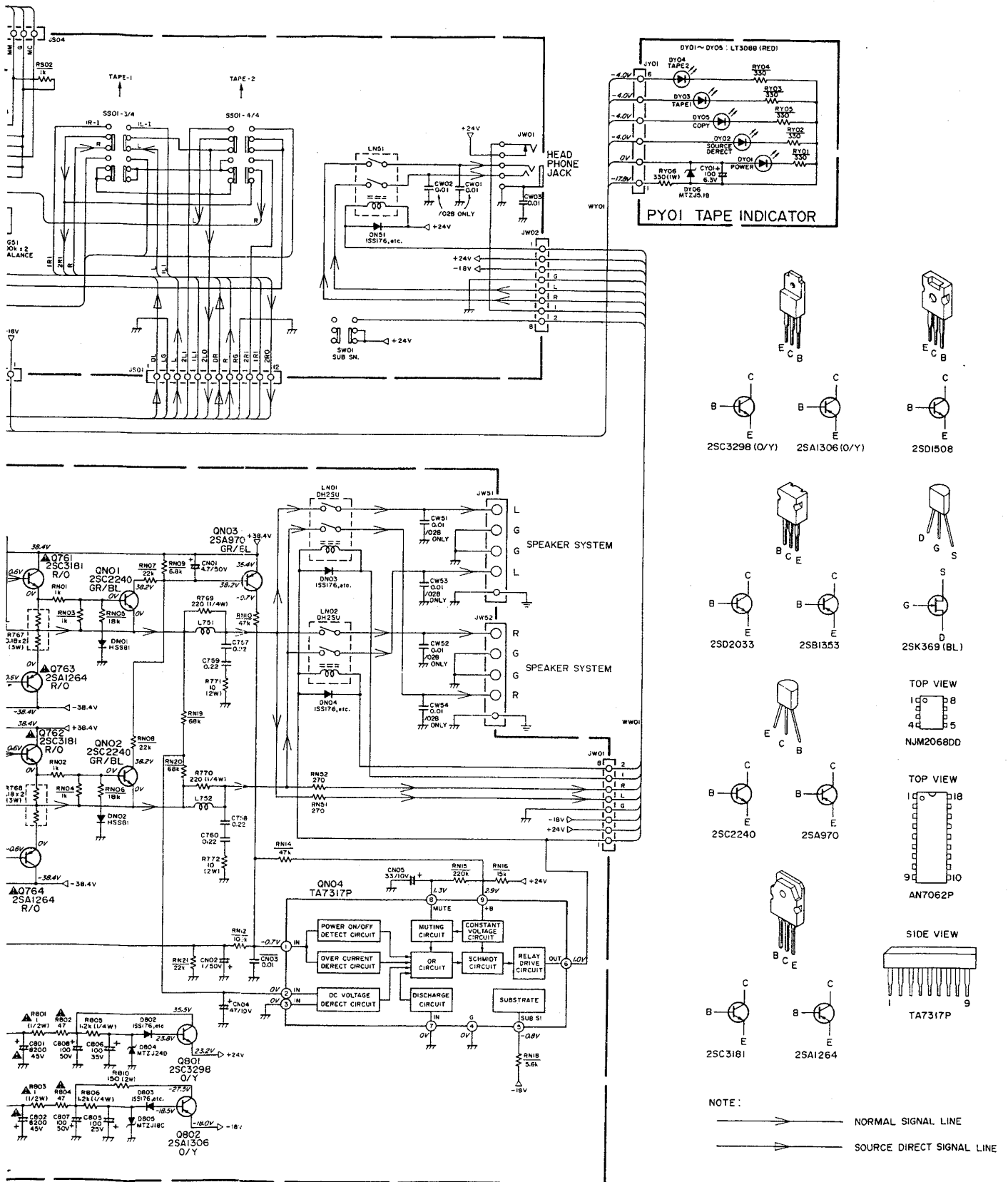

critical shock hazard. Only original parts should be used. Any part marked with symbol \blacktriangle . Any other component than original type, may increase risk of hazard.

MARANTZ DESIGN AND SERVICE

Using superior design and selected high grade components, MARANTZ company has created the ultimate in stereo sound.

Only **original MARANTZ parts** can insure that your MARANTZ product will continue to perform to the specifications for which it is famous.

Parts for your MARANTZ equipment are generally available to our National Marantz Subsidiary or Agent.

ORDERING PARTS:

Parts can be ordered either by mail or by telex. In both cases, correct part number has to be specified. The following information must be supplied to eliminate delays in processing your order:

1. Complete address
2. Complete part numbers and quantities required
3. Description of parts
4. Model number for which part is required
5. Way of shipment
6. Signature: any order form or telex must be signed otherwise such part order will be considered as null and void.

PARTS ORDERING

Parts may be ordered at the following addresses:

AUSTRIA HORNYPHON Vertriebsgesellschaft GmbH Wienerbergstrasse 1 A 1101 Wien Austria Telex: 132.332	FINLAND MARANTZ DIVISION OF OY PHILIPS Ab Kaivokatu 8 00100 Helsinki Finland Telex: 124811	GREAT BRITAIN MARANTZ AUDIO U.K. Ltd Unit 15/16 Saxon Way Industrial Estate Moor Lane Harmondsworth UB7 0LW Great Britain Telex: 935196	SAUDI ARABIA AL ALAMIAH ELECTRONICS P.O.Box 5954 University Street Riyadh 11432 Saudi Arabia Telex: 401530	SWITZERLAND MARANTZ Technischer Service Duenstrasse 3 3186 Dürdingen Switzerland
BELGIUM SVD DIVISION MARANTZ Industrialaan 1 1720 Groot-Bijgaarden Belgium Telex: 24466	FRANCE MARANTZ FRANCE 4 Rue Bernard Palissy 92600 Asnières France Telex: 611651	GREECE SHERTON ELECTRONICS S.A. P.O.Box 21025 Hippocrates Street 188 Athens 11471 Greece Telex: 216.795	SOUTH AFRICA MARANTZ DIVISION OF PHILIPS S.A. Main Road Martindale P.O. Box. 58088 Newville 21114 South Africa	TURKEY DOGRUOL Ltd. I.M.C. 6 Blok N°6310 Unkapani Istanbul Turkey Telex: 22085
CHILE MARANTZ DIVISION OF PHILIPS S.A. AV. Santa Maria, 0760 Casilla 2687 Santiago Telex: 240.239	GERMANY MARANTZ GERMANY GmbH Alexanderstrasse 1 2000 Hamburg Germany	JAPAN MARANTZ JAPAN, Inc. 35-1, 7-chome, Sagamiono Sagamihara-shi, Kanagawa Japan	SPAIN PHONO S.A. Ignacio Iglesias 10 Badalona (Barcelona) Spain Telex: 59355	MALTA CACHIA & GALEA Republic Street, 68D Valetta Telex: 1682
DENMARK MARANTZ DIVISION OF PHILIPS SERVICE A/S Prags Boulevard 80 Postbox 1919 DK-2300 København S Denmark Telex: 31201	THE NETHERLANDS Elpro Marantz Wint Hontlaan 28 3526 KV Utrecht The Netherlands Telex: 4748	KUWAIT AL ALAMIAH ELECTRONICS Ussama Building Fahd al Saleem Street P.O.Box 23781 Safat-Kuwait Telex: 22694	SWEDEN MARANTZ DIVISION OF PHILIPS Försäljning AB Tegeluddsvägen 1 S-115 84 Stockholm Sweden Telex: 14060	PORTUGAL MARANTZ Divisao philips S.A. service Couturela-carnaxide 2795 Linda-A-VELHA Telex: 43906
	NORWAY MARANTZ DIVISION OF PHILIPS A/S Sandstuveien 40 0680 Oslo 6 Norway Telex: 72640	ITALY MARANTZ ITALIANA S.P.A. Via Chiese, 74 20126 Milano Italy		

MARANTZ INTERNATIONAL
Vestdijk 9
5600 MD Eindhoven
The Netherlands
Phone: +31/40.758290
Telefax: +31/40.75.82.99
Telex: 35000 PHTC NL routing IND NLMTFAT

All of the above locations are fully equipped to take care of your total service needs. Because various countries have differing configuration requirements, it is necessary that you contact the service facility in your particular country. In the event that there is no service location listed for your country, please, contact the nearest facility for the necessary assistance.

In case of difficulties, do not hesitate to contact the Technical Department at abovementioned address.

TECHNICAL SPECIFICATIONS (DIN)

Power Amplifier Section

IHF Dynamic Power	: 100W
2 ohms	: 80W
4 ohms	: 54W
8 ohms	

Power Output Per Channel

DIN 8 ohms	1 kHz 1% THD	: 48W
FTC 4 ohms	40-20 kHz 0.15% THD	: 55W
FTC 8 ohms	40-20 kHz 0.08% THD	: 43W

Total Harmonic Distortion at 8 ohms	: 0.015%
I.M. Distortion at 8 ohms	: 0.015%
Damping Factor	: 100

Phono Amplifier Section

MM Cartridge Input	
Frequency Difference	: ±0.5 dB
Signal to Noise Ratio (A weighted)	: 87 dB
Input Sensitivity	: 2.5 mV
Input Impedance	: 47k Ohms

High Level Section

Frequency Response	: 10-60 kHz
Signal to Noise Ratio (A weighted)	: 87 dB
Input Sensitivity	: 150 mV
Input Impedance	: 33k Ohms
Tape Output Level [Phono (MM) 5 mV 1 kHz Input]	: 300 mV
Tape Output Impedance (Phono)	: 220 Ohms
	: 440 Ohms (only /02B/12B version)
Tone Control Action	100 Hz
	10 kHz
	: ±6 dB

General

Power Requirements	: 220V/240V
2 Voltage version	: 110V-240V
4 Voltage version	

Power Consumption (Rated Power)

AB Class Moode	: 170W
A Class Moode	: -

Dimensions

Panel Width	: 420 mm
Panel Height	: 118 mm
Depth	: 280 mm

Weight

Unit alone	: 10 kg
------------	---------

Specifications and appearance are subject to change for modification without notice.

1. BLOCK DIAGRAM

PM-40

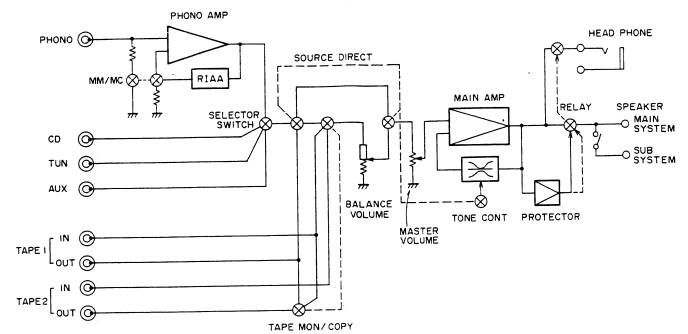

PM-40SE

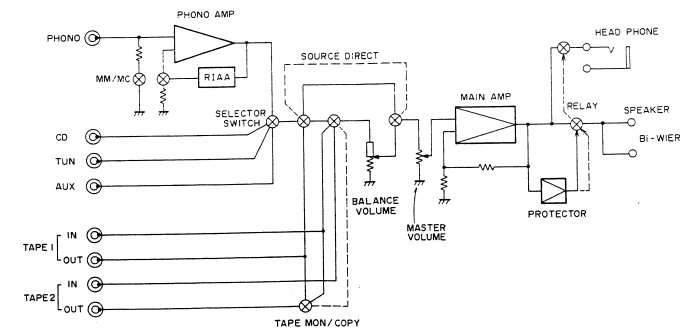

2. SCHEMATIC DIAGRAM AND PARTS LOCATION (Pattern side)

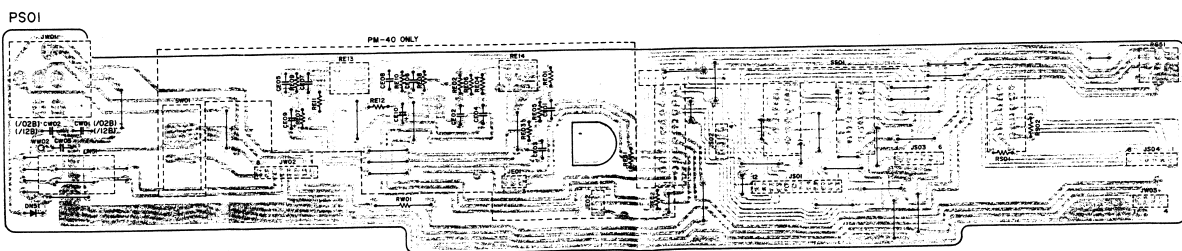
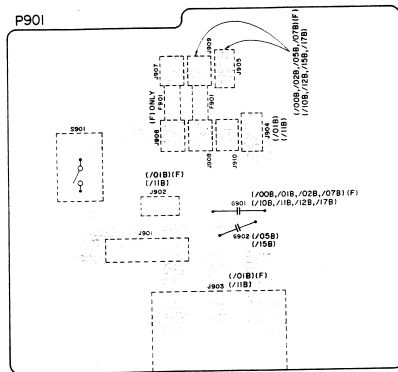
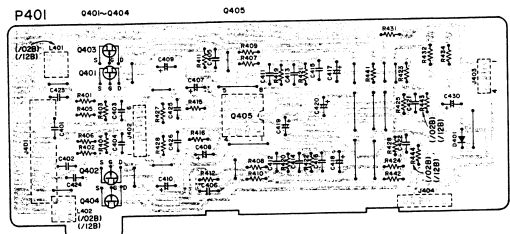
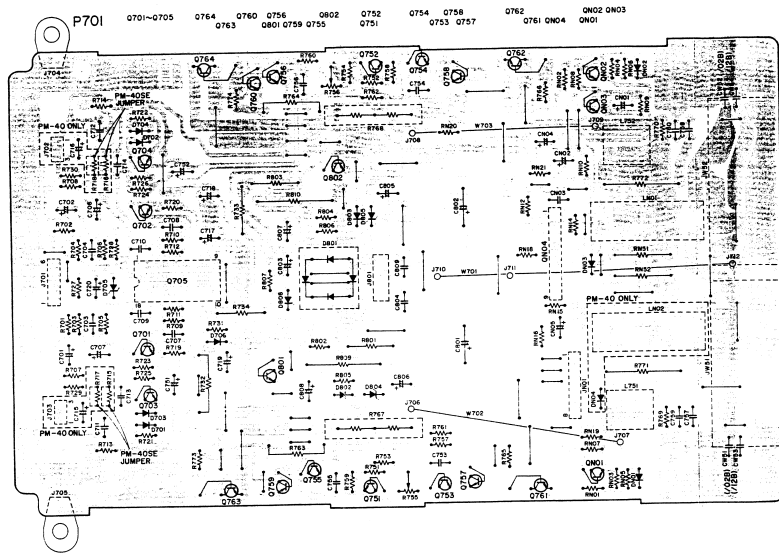

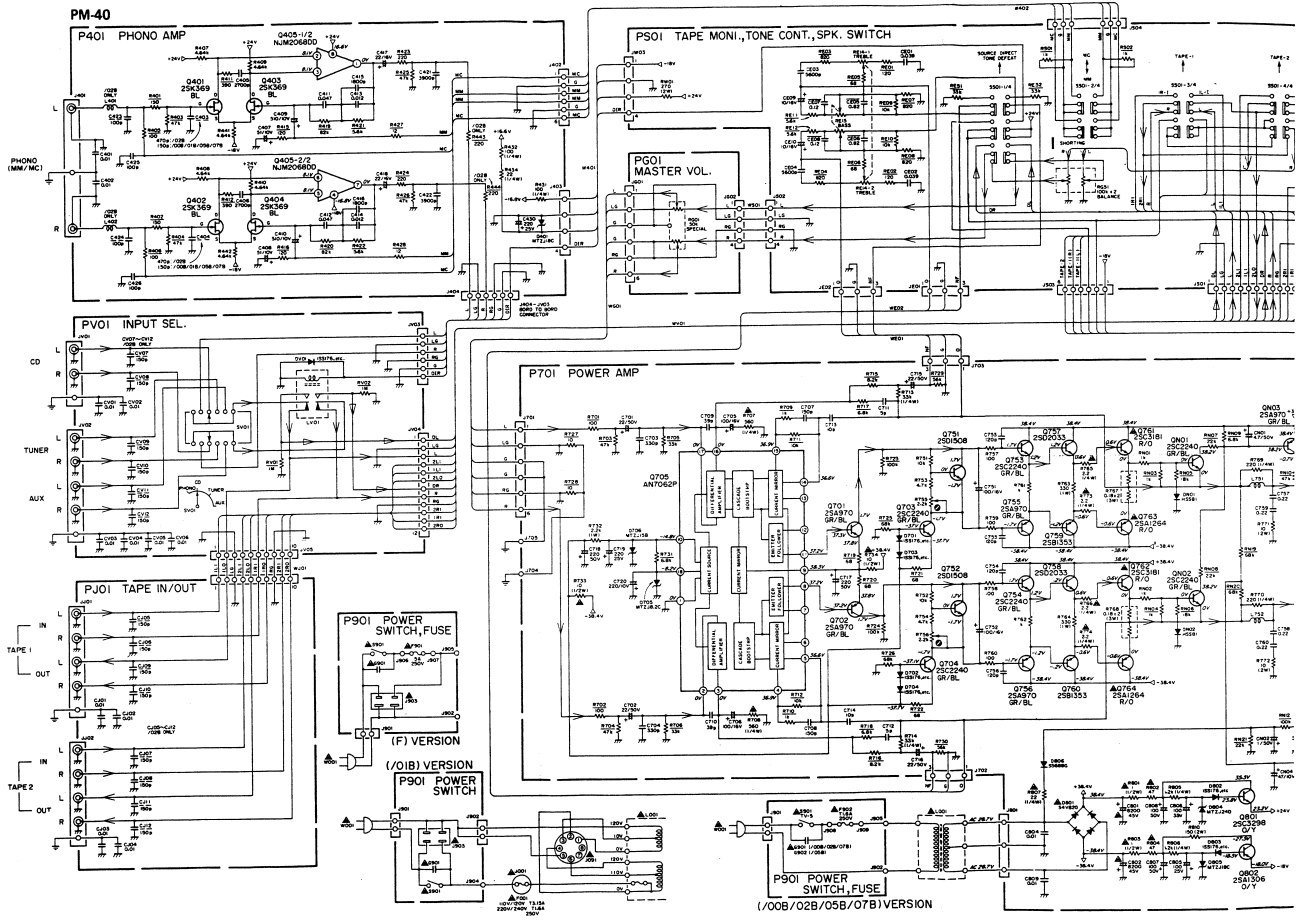

NOTE ON SAFETY:
 Symbol ▲ Fire or electrical shock hazard. Only original part be used to replace any part marked with symbol ▲. Any component substitution (other than original type), may increase fire or electrical shock hazard.

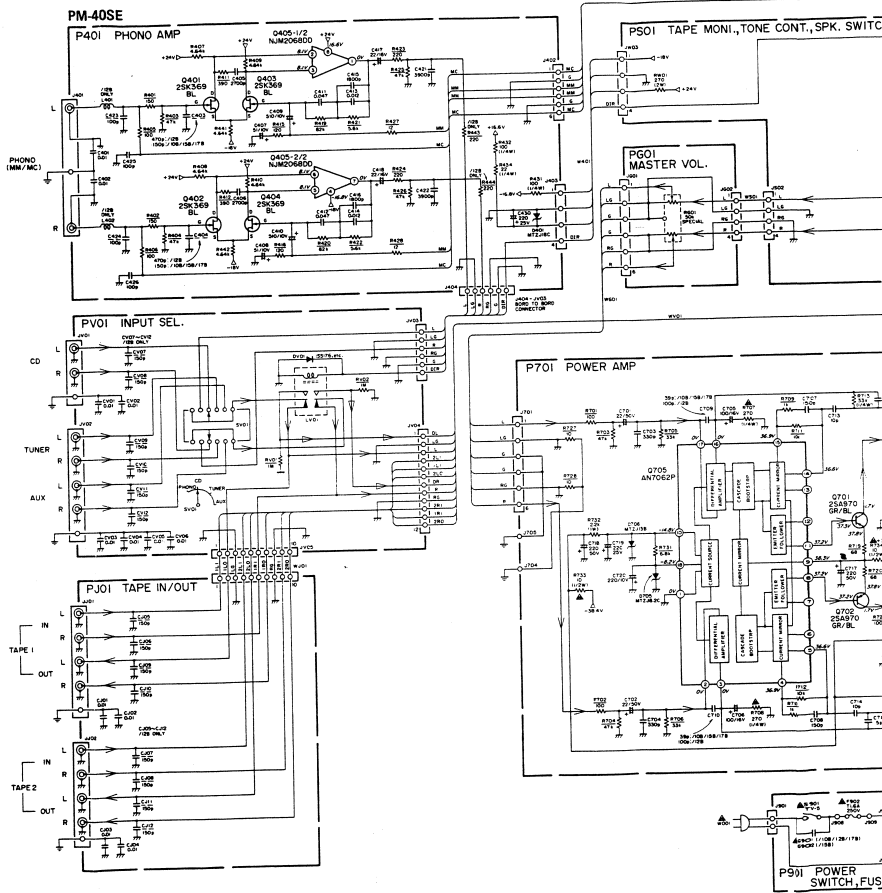
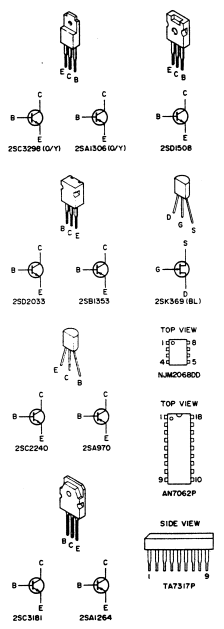
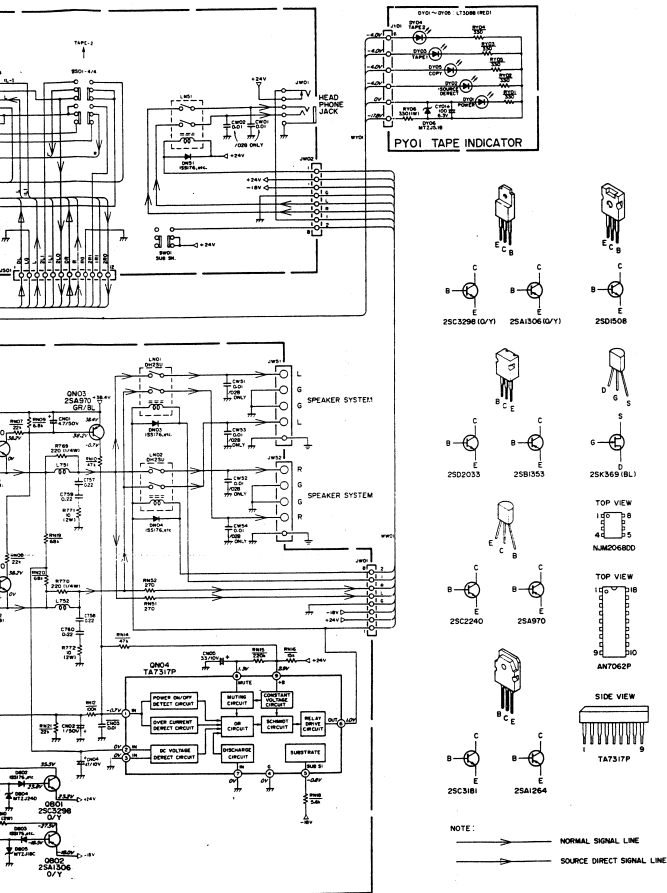

ward. Only original parts should
sh symbol ▲. Any other com.
l type, may increase risk of fire

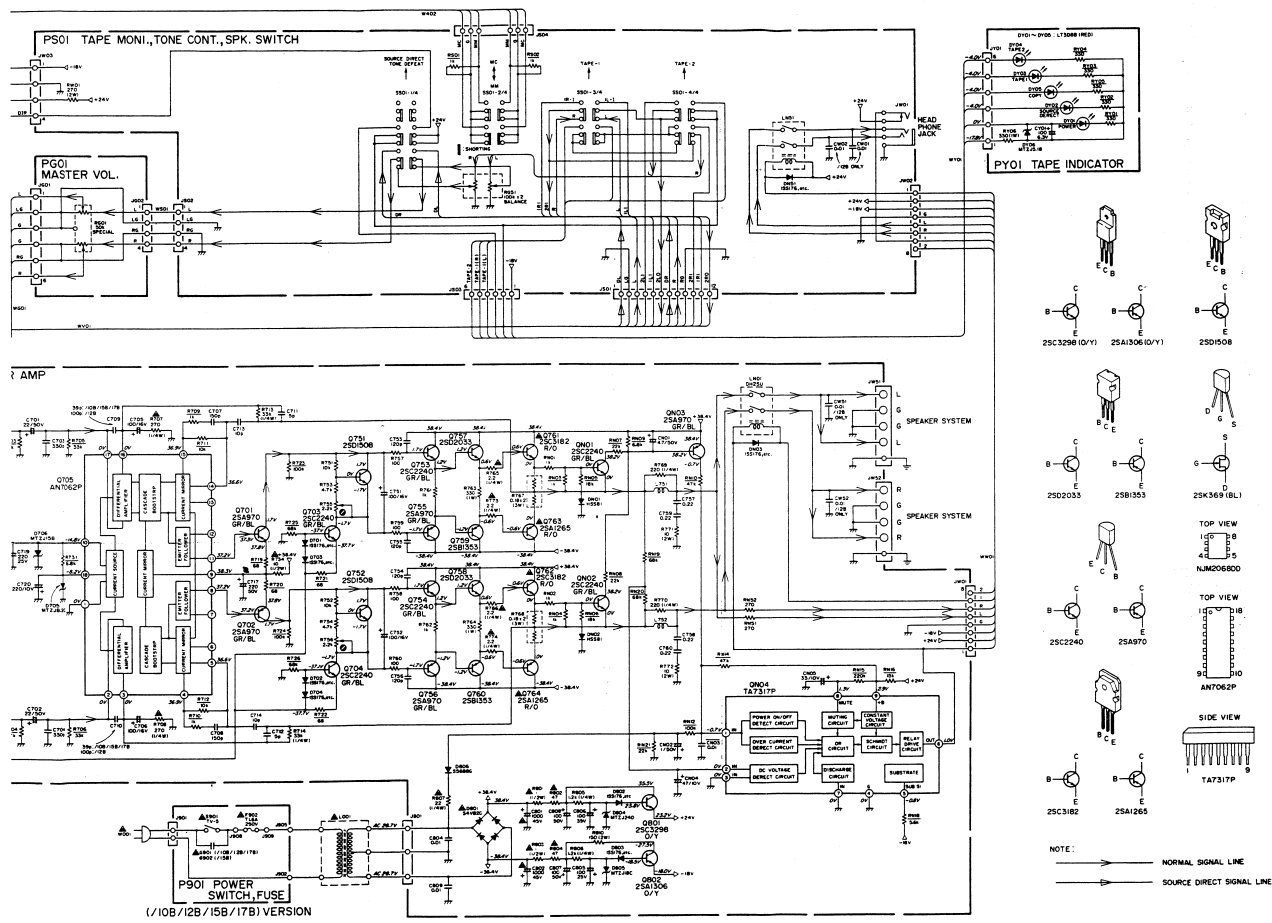

NOTE ON SAFETY:
 Symbol ▲ Fire or electrical shock hazard. Only original parts should be used to replace any part marked with symbol ▲. Any other component substitution (other than original type), may increase risk of fire or electrical shock hazard.

PV01

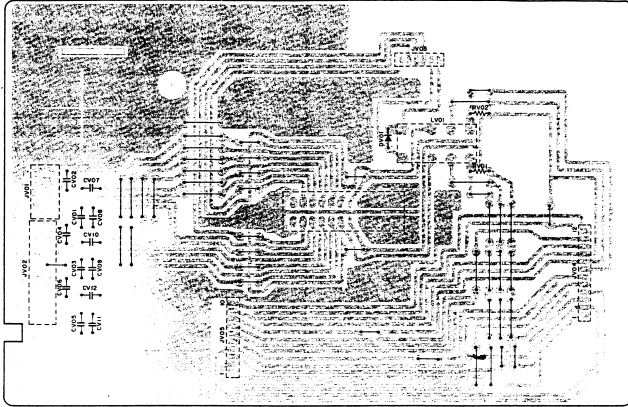

PJ01

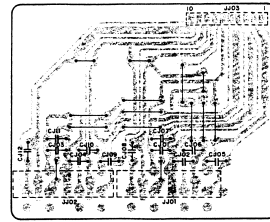

PG01

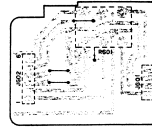

PY01



3. EXPLODED VIEW AND PARTS LIST

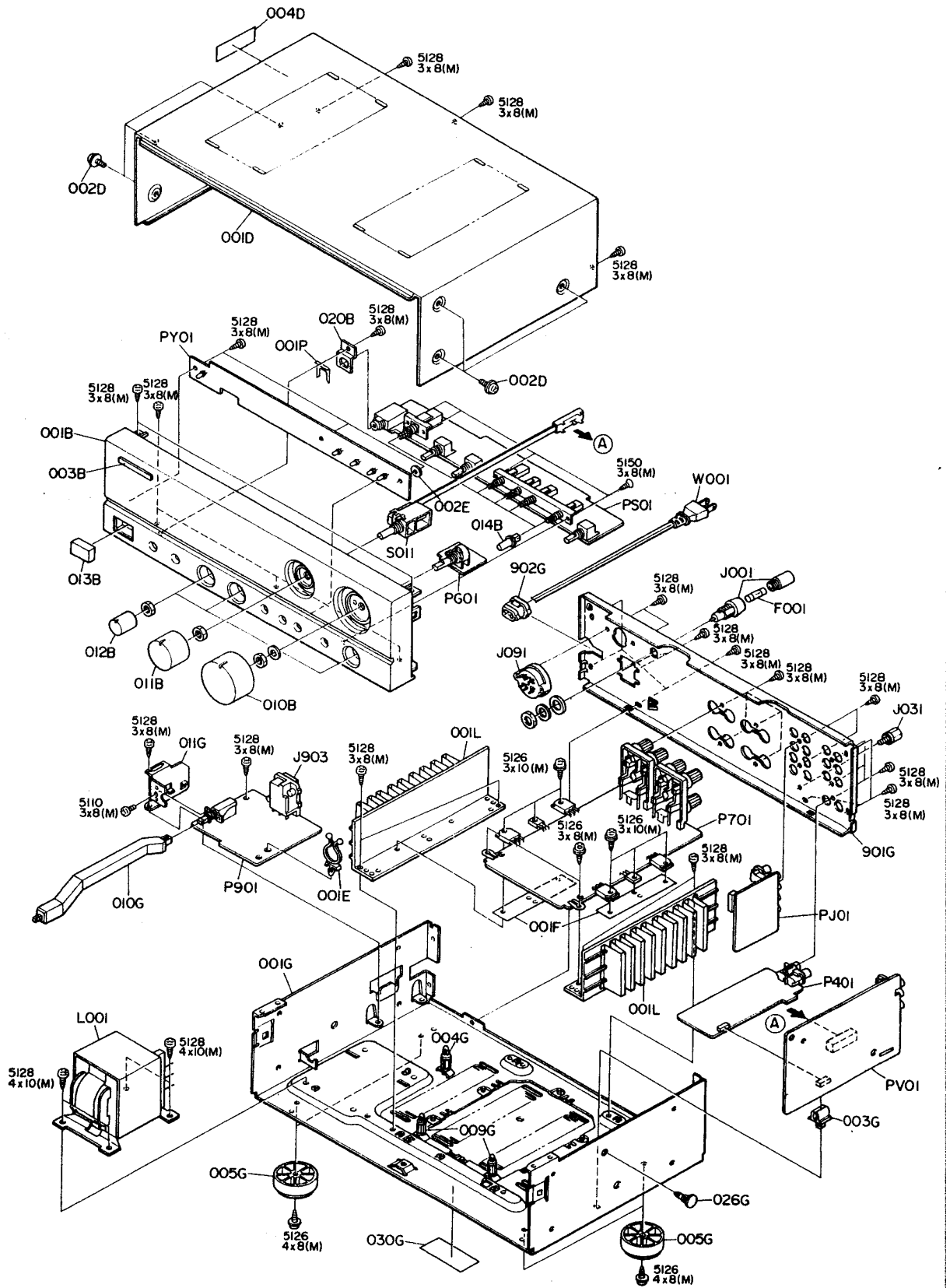

REF. DESIG.	PART NO.	DESCRIPTION
001B	4822 425 40177	Front Panel Assembly /00B/01B/02B/05B/07B
	4822 425 40178	Front Panel Assembly /10B/12B/15B/17B
003B	4822 459 10943	Badge
010B	4822 413 41544	Knob, Volume
011B	4822 413 41545	Knob, Selector
012B	4822 413 41589	Knob, Tone/Balance
	4822 413 31551	Knob, Tone/Balance /00B/01B/02B/05B/07B /10B/12B/15B/17B
013B	4822 410 60395	Button, Power
014B	4822 410 60343	Button, Speaker
002D	4822 501 11008	Screw
001F	4822 466 92914	Sheet, DENKA
005G	4822 462 41477	Leg
010G	4822 404 60628	Link, Power Switch
902G	4822 532 60948	Bushing, AC Cord /00B/01B/02B/07B/10B/12B/17B
902G	4822 532 61184	Bushing, AC Cord /05B/15B
001P	4822 401 11351	Clamper, Phono Jack
▲ F001	4822 253 30191	Fuse, T1.6A 250V /01B
F002	4822 253 30027	Fuse, T3.15A 250V /01B
▲ J001	4822 256 30233	Jack, Fuse Holder /01B
J031	4822 290 40297	Terminal, GND
▲ J091	4822 272 10227	Voltage Selector /01B
J092	4822 265 10092	Jack, AC Adapter /01B
▲ J903	4822 264 30313	Jack, AC Outlet
▲ L001	4822 146 21552	Power Transformer /00B/02B/05B/07B/10B/12B/15B/17B
	4822 146 21555	Power Transformer /01B
S011	4822 273 10214	Rotary Switch, Selector
001T	4822 736 20695	User Manual /00B/01B/02B/05B/07B
	4822 736 20715	User Manual /10B/12B/15B/17B

4. IDLING CURRENT ADJUSTMENT

- (1) Before switching the power ON, set the Master Volume control to the minimum position and the Balance and Tone controls to the center positions. Also set semi-fixed resistors R755 (L CH) and R756 (R CH) on PCB P701 to the center positions.
- (2) Each of the cement resistors R767 (L CH) and R768 (R CH) on the PCB P701 is provided with three test points. Connect a digital voltmeter, set for the DC voltage input, to the test points at the two extremities of the three test points of R767 or R768.
- (3) After the setup above, switch the power ON and adjust semi-fixed resistor R755 (L CH) or R756 (R CH) on PCB P701 according to the digital voltmeter reading. The target setting value is 14 mV (38.9 mA) for both the L CH and R CH.

Please refer to the table below.

Elapsed time after power ON	Idling current setting value
30 sec. - 1 min.	5 mV
1 min. - 2 min.	8 mV
2 min. - 4 min.	10.5 mV
More than 4 min.	14 mV

Note on Safety:

Symbol ▲ Fire or electrical shock hazard. Only original parts should be used to replace any part marked with symbol ▲. Any other component substitution (other than original type), may increase risk of fire or electrical shock hazard.

5. HOW TO CHANGE THE SUPPLY VOLTAGE (/00B/02B/05B/07B/10B/12B/15B/17B Versions)

With the /05B/07B/15B/17B Versions, the rated supply voltage of 240V can be changed to 220V. In the same way, the 220V rated supply voltage of the /00B/02B/10B/12B Versions can be changed to 240V.

Refer to the following diagram for the voltage change procedure.

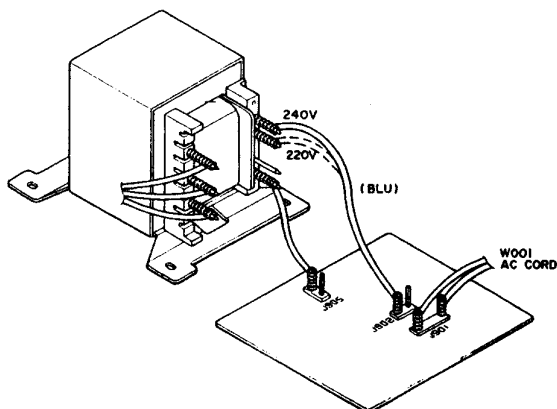

6. TEST EQUIPMENT REQUIRED FOR SERVICING

This table lists the test equipment required for servicing

Item	Use
Distortion Analyzer	Distortion measurements
Audio Oscillator	Sinewave and squarewave signal source
ACVTVM	Voltage measurements (AC)
Oscilloscope	Waveform analysis and trouble shooting and ASO aignment
Circuit Tester	Trouble shooting
DCVTVM	Voltage measurements (DC)
AC Wattmeter	Monitors primary power to amplifier
Line Voltmeter	Monitors potential of primary power to amplifier
Variable Autotransformer	Adjust level of primery power to amplifier
Shorting Plug	Shorts amplifier input to eliminate noise pickup

7. VOLTAGE CONVERSION

• EUROPEAN MODEL ONLY

To convert the unit to a different power source voltage, change the position as illustrated in the drawing below.

VOLTAGE SELECTOR

CAUTION
DISCONNECT POWER SUPPLY CORD FROM AC
OUTLET BEFORE CONVERTING VOLTAGE.

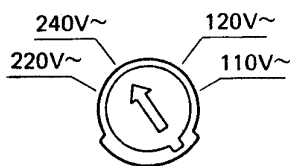
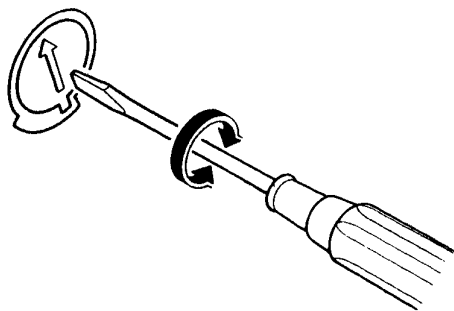

8. ELECTRICAL PARTS LIST

ASSIGNMENT OF COMMON PARTS CODES.

RESISTOR

R***: (1) GD05 --- 140, Carbon film fixed resistor, $\pm 5\%$, 1/4W

R***: (2) GD05 --- 160, Carbon film fixed resistor, $\pm 5\%$, 1/6W

① --- Resistance value

Examples

① Resistance value
 0.1 Ω ...001 10 Ω ...100 1k Ω ...102 100k Ω ...104
 0.5 Ω ...005 18 Ω ...180 2.7k Ω ...272 680k Ω ...684
 1 Ω ...010 100 Ω ...101 10k Ω ...103 1M Ω ...105
 6.8 Ω ...068 390 Ω ...391 22k Ω ...223 4.7M Ω ...475

(Note) Please distinguish 1/4W from 1/6W by the shape of parts used actually.

C***: CERAMIC CAP.

(1) DD1 --- 370, Ceramic condenser
 Disc type
 Temp. coeff. P350 ~ N1000, 50V

① ②
 Capacity value
 Tolerance

Examples

① Tolerance (Capacity deviation)
 $\pm 0.25\text{pF}$...0
 $\pm 0.5\text{pF}$...1
 $\pm 5\%$...5

* Tolerance of COMMON PARTS handled here are as follows:

0.5pF ~ 5pF... $\pm 0.25\text{pF}$

6pF ~ 10pF... $\pm 0.5\text{pF}$

12pF ~ 560pF... $\pm 5\%$

② Capacity value
 0.5pF...005 3pF...030 100pF...101
 1pF...010 10pF...100 220pF...221
 1.5pF...015 47pF...470 560pF...561

C***: CERAMIC CAP.

(1) DK16 --- 300, High dielectric constant ceramic condenser
 Disc type
 Temp. chara. 2B4, 50V

①
 Capacity value

Example

② Capacity value
 100pF...101 1000pF...102 10000pF...103
 470pF...471 2200pF...222

C***: ELECTROLY CAP. (E), FILM CAP. (F)

(1) EA --- 10, Electrolytic condenser
 One-way lead type, Tolerance $\pm 20\%$

① ②
 Dielectric strength
 Capacity value

Examples

① Capacity value
 0.1 μF ...104 4.7 μF ...475 100 μF ...107
 0.33 μF ...334 10 μF ...106 330 μF ...337
 1 μF ...105 22 μF ...226 1100 μF ...108
 2200 μF ...228

② Working voltage
 6.3V...006 25V...025
 10V...010 35V...035
 16V...016 50V...050

(2) DF15 --- 350, Plastic film condenser
 One-way type, Mylar $\pm 5\%$ 50V

①
 Capacity value

Examples

① Capacity value
 0.001 μF (1000pF)...102 0.1 μF ...104
 0.0018 μF ...182 0.56 μF ...564
 0.01 μF ...103 1 μF ...105
 0.015 μF ...153

REF. DESIG.	PART NO.	DESCRIPTION
		PG01-MASTER VOLUME CIRCUIT BOARD
RG01	4822 101 30653	Variable Resistor 50K Ω
		PJ01-TAPE IN/OUT CIRCUIT BOARD
CJ01 } CJ04	4822 122 32486	Ceramic Cap. 0.01 μF +80% -20%
JJ01 JJ02	4822 266 30284 4822 266 30284	Terminal, 4P RCA Terminal, 4P RCA
		PS01-TAPE/TONE/SPK. CIRCUIT BOARD
CE01	4822 121 43133	Film Cap. 0.039 μF $\pm 5\%$ /00B/01B/02B/05B/07B
CE02	4822 121 43133	Film Cap. 0.039 μF $\pm 5\%$ /00B/01B/02B/05B/07B
CE03	4822 121 51389	Film Cap. 5600pF $\pm 5\%$ /00B/01B/02B/05B/07B
CE04	4822 121 51389	Film Cap. 5600pF $\pm 5\%$ /00B/01B/02B/05B/07B
CE09	4822 124 90352	Elect Cap. 10 μF 16V /00B/01B/02B/05B/07B
CE10	4822 124 90352	Elect Cap. 10 μF 16V /00B/01B/02B/05B/07B
CW01	4822 122 32486	Ceramic 0.01 μF +80% -20% /02B/12B
CW02	4822 122 32486	Ceramic 0.01 μF +80% -20% /02B/12B
RE13	4822 100 30139	Variable Resistor 50K Ω (C) /00B/01B/02B/05B/07B
RE14	4822 100 30139	Variable Resistor 50K Ω (C) /00B/01B/02B/05B/07B
RG51	4822 100 30138	Variable Resistor 100K Ω (MN)
RW01	4822 116 60455	Metal Resistor 270 Ω $\pm 5\%$ 2W
DN51	4822 130 33305	Diode 1SS176, etc.
JW01	4822 267 31227 4822 267 31229	Jack, Headphone /00B/01B/02B/05B/07B Jack, Headphone /10B/12B/15B/17B
LN51	4822 280 20196	Relay
SS01	4822 276 12197	Push Switch
SW01	4822 276 12218	Push Switch /00B/01B/02B/05B/07B
		PV01-INPUT SELECTOR CIRCUIT BOARD
CV01 } CV06	4822 122 32486	Ceramic Cap. 0.01 μF +80% -20%
DV01	4822 130 33305	Diode 1SS176, etc.
JV01 JV02	4822 266 30282 4822 266 30284	Terminal, 2P RCA Terminal, 4P RCA
LV01	4822 280 20195	Relay, SZ-2104
SV01	4822 277 21412	Slide Switch, Selector

REF. DESIG.	PART NO.	DESCRIPTION
		PY01-TAPE INDICATOR CIRCUIT BOARD
CY01	4822 124 21737	Elect Cap. 100 μ F 6.3V
RY06	4822 111 50474	Resistor 330 Ω \pm 5%
DY01 }	4822 130 80326	L.E.D. LT3D8B (RED)
DY05 DY06	4822 130 80317	Zener Diode RD5.1JB2/MTZJ5.1B
		P401-PHONO AMP. CIRCUIT BOARD
		P401-CAPACITORS
C401	4822 122 32486	Ceramic 0.01 μ F +80% -20%
C402	4822 122 32486	Ceramic 0.01 μ F +80% -20%
C403	4822 126 11069	Ceramic 150pF \pm 10% /00B/01B/05B/07B
C403	4822 121 51037	Film 150pF \pm 5% /10B/15B/17B
C404	4822 126 11069	Ceramic 150pF \pm 10% /00B/01B/05B/07B
C404	4822 121 51037	Film 150pF \pm 5% /10B/15B/17B
C405	4822 121 42761	Film 2700pF \pm 5%
C406	4822 121 42761	Film 2700pF \pm 5%
C407	4822 124 22278	Elect 51 μ F 10V
C408	4822 124 22278	Elect 51 μ F 10V
C409	4822 124 22279	Elect 510 μ F 10V
C410	4822 124 22279	Elect 510 μ F 10V
C411	4822 121 42764	Film 0.047 μ F \pm 5%
C412	4822 121 42764	Film 0.047 μ F \pm 5%
C413	4822 121 42755	Film 0.012 μ F \pm 5%
C414	4822 121 42755	Film 0.012 μ F \pm 5%
C415	4822 121 42758	Film 1800pF \pm 5%
C416	4822 121 42758	Film 1800pF \pm 5%
C417	4822 124 90358	Elect 22 μ F 16V
C418	4822 124 90358	Elect 22 μ F 16V
C419	4822 124 90365	Elect 220 μ F 25V
C420	4822 124 90365	Elect 220 μ F 25V
C421	4822 121 42763	Film 3900pF \pm 5%
C422	4822 121 42763	Film 3900pF \pm 5%
C430	4822 124 90365	Elect 220 μ F 25V
		P401-RESISTORS
R407 }	4822 116 53691	4.64K Ω \pm 1% 1/6W
R410		
R431	4822 116 52892	100 Ω \pm 5% 1/4W
R432	4822 116 52892	100 Ω \pm 5% 1/4W
R434	5322 116 53479	22 Ω \pm 5% 1/4W
R441	4822 116 53691	4.64K Ω \pm 1% 1/6W
R442	4822 116 53691	4.64K Ω \pm 1% 1/6W
		P401-SEMICONDUCTORS
D401	4822 130 80838	Zener RD18JB2/MTZJ18C
Q401 }	4822 130 42839	F.E.T. 2SK369(BL)
Q404 Q405	4822 209 73064	IC NJM2068DD
		P401-MISCELLANEOUS
J401	4822 265 20355	Terminal, 2P RCA
L401	4822 156 11019	Choke Coil, 320 μ H [/02B/12B]
L402	4822 156 11019	Choke Coil, 320 μ H [/02B/12B]

REF. DESIG.	PART NO.	DESCRIPTION
		P701-POWER AMP. CIRCUIT BOARD
		P701-CAPACITORS
CN01	4822 124 22274	Elect 4.7 μ F 50V
CN02	4822 124 41543	Elect 1 μ F 50V
CN04	4822 124 22275	Elect 47 μ F 10V
CN05	4822 124 23417	Elect 33 μ F 10V
CW51	4822 122 32486	Ceramic 0.01 μ F +80% -20% [/02B/12B]
CW52	4822 122 32486	Ceramic 0.01 μ F +80% -20% [/02B/12B]
CW53	4822 122 32486	Ceramic 0.01 μ F +80% -20% [/02B]
CW54	4822 122 32486	Ceramic 0.01 μ F +80% -20% [/02B]
C701	4822 124 90362	Elect 22 μ F 50V
C702	4822 124 90362	Elect 22 μ F 50V
C703	4822 126 11071	Ceramic 330pF \pm 10%
C704	4822 126 11071	Ceramic 330pF \pm 10%
C705	4822 124 90354	Elect 100 μ F 16V
C706	4822 124 90354	Elect 100 μ F 16V
C707	4822 121 51037	Film 150pF \pm 5%
C708	4822 121 51037	Film 150pF \pm 5%
C709	4822 126 11068	Ceramic 39pF \pm 5% /00B/01B/05B/07B
	4822 126 10364	Ceramic 100pF \pm 5% /02B/12B
	4822 121 43135	Film 30pF \pm 10% /10B/15B/17B
C710	4822 126 11068	Ceramic 39pF \pm 5% /00B/01B/05B/07B
	4822 126 10364	Ceramic 100pF \pm 5% /02B/12B
	4822 121 43135	Film 30pF \pm 10% /10B/15B/17B
C711	4822 121 43127	Film 5pF \pm 10%
C712	4822 121 43127	Film 5pF \pm 10%
C713	4822 121 43128	Film 10pF \pm 10%
C714	4822 121 43128	Film 10pF \pm 10%
C715	4822 124 90362	Elect 22 μ F 50V /00B/01B/02B/05B/07B
C716	4822 124 90362	Elect 22 μ F 50V /00B/01B/02B/05B/07B
C717	4822 124 90366	Elect 22 μ F 50V
C718	4822 124 90366	Elect 22 μ F 50V
C719	4822 124 90365	Elect 22 μ F 25V
C720	4822 124 90363	Elect 22 μ F 10V
C751	4822 124 90354	Elect 10 μ F 16V
C752	4822 124 90354	Elect 10 μ F 16V
C753	4822 121 43126	Film 12pF \pm 5%
C754	4822 121 43126	Film 12pF \pm 5%
C755	4822 121 43126	Film 12pF \pm 5%
C756	4822 121 43126	Film 12pF \pm 5%
▲ C801	4822 124 42042	Elect 820 μ F 45V /00B/01B/02B/05B/07B
▲ C801	4822 124 42043	Elect 1000 μ F 45V /10B/12B/15B/17B
▲ C802	4822 124 42042	Elect 820 μ F 45V /00B/01B/02B/05B/07B
▲ C802	4822 124 42043	Elect 1000 μ F 45V /10B/12B/15B/17B
C804	4822 122 32486	Ceramic 0.01 μ F +80% -20%
C805	4822 124 41535	Elect 10 μ F 25V
C806	4822 124 41536	Elect 10 μ F 35V
C807	4822 124 90355	Elect 10 μ F 50V
C808	4822 124 90355	Elect 10 μ F 50V
C809	4822 122 32486	Ceramic 0.01 μ F +80% -20%

REF. DESIG.	PART NO.	DESCRIPTION
P701-RESISTORS		
RN01	4822 111 91257	1K Ω $\pm 5\%$ 1/6W
RN02	4822 111 91257	1K Ω $\pm 5\%$ 1/6W
RN51	4822 116 60455	270 Ω $\pm 5\%$ 2W, Metal
RN52	4822 116 60455	270 Ω $\pm 5\%$ 2W, Metal
▲ R707	4822 113 90231	560 Ω $\pm 2\%$ ¼W, Fuse
▲ R707	4822 116 80828	270 Ω $\pm 2\%$ ¼W [/12B/15B]
▲ R708	4822 113 90231	560 Ω $\pm 2\%$ ¼W, Fuse
▲ R708	4822 116 80828	270 Ω $\pm 2\%$ ¼W [/12B/15B]
R713	4822 050 23303	33K Ω $\pm 5\%$ ¼W
R714	4822 050 23303	33K Ω $\pm 5\%$ ¼W
R732	4822 116 60346	2.2K Ω $\pm 5\%$ 1W
▲ R733	4822 116 60313	10 Ω $\pm 5\%$ ¼W, Fusible
▲ R734	4822 116 60313	10 Ω $\pm 5\%$ ¼W, Fusible
R755	4822 100 20681	2.2K Ω , Trimming
R756	4822 100 20681	2.2K Ω , Trimming
R757	4822 111 91285	100 Ω $\pm 5\%$ 1/6W
R758	4822 111 91285	100 Ω $\pm 5\%$ 1/6W
R759	4822 111 91285	100 Ω $\pm 5\%$ 1/6W
R760	4822 111 91285	100 Ω $\pm 5\%$ 1/6W
R761	4822 111 91257	1K Ω $\pm 5\%$ 1/6W
R762	4822 111 91257	1K Ω $\pm 5\%$ 1/6W
R763	4822 111 50474	330 Ω $\pm 5\%$ 1W
R764	4822 111 50474	330 Ω $\pm 5\%$ 1W
▲ R765	4822 116 52348	2.2 Ω $\pm 5\%$ ¼W
▲ R766	4822 116 52348	2.2 Ω $\pm 5\%$ ¼W
R767	4822 116 82049	0.18 Ω x2 $\pm 10\%$ 3W
R768	4822 116 82049	0.18 Ω x2 $\pm 10\%$ 3W
R769	4822 116 52849	220 Ω $\pm 5\%$ ¼W
R770	4822 116 52849	220 Ω $\pm 5\%$ ¼W
R771	4822 111 90726	10 Ω $\pm 5\%$ 2W
R772	4822 111 90726	10 Ω $\pm 5\%$ 2W
▲ R773	4822 116 52348	2.2 Ω $\pm 5\%$ ¼W
▲ R774	4822 116 52348	2.2 Ω $\pm 5\%$ ¼W
▲ R801	4822 116 60306	1 Ω $\pm 5\%$ ¼W, Fusible
▲ R802	4822 111 90731	47 Ω $\pm 2\%$ ¼W, Fuse
▲ R803	4822 116 60306	1 Ω $\pm 5\%$ ¼W, Fusible
▲ R804	4822 111 90731	47 Ω $\pm 2\%$ ¼W, Fuse
R805	4822 111 91423	1.2K Ω $\pm 5\%$ ¼W
R806	4822 111 91423	1.2K Ω $\pm 5\%$ ¼W
▲ R807	4822 113 90119	22 Ω $\pm 2\%$ ¼W, Fuse
R810	4822 116 60338	150 Ω $\pm 5\%$ 2W
P701-SEMICONDUCTORS		
DN01	4822 130 80837	Diode HSS81
DN02	4822 130 80837	Diode HSS81
DN03	4822 130 33305	Diode 1SS176, etc.
DN04	4822 130 33305	Diode 1SS176, etc.
D701	4822 130 33305	Diode 1SS176, etc.
D704		
D705		
D706		
▲ D801	4822 130 31007	Diode S4VB-20
D802	4822 130 33305	Diode 1SS176, etc.
D803	4822 130 33305	Diode 1SS176, etc.
D804	4822 130 80116	Zener RD24JB2/MTZJ24D
D805	4822 130 80838	Zener RD18JB2/MTZJ18C
▲ D806	4822 130 80839	Diode S5688G
QN01	4822 130 43233	Transistor 2SC2240(GR, BL)
QN02	4822 130 43233	Transistor 2SC2240(GR, BL)
QN03	4822 130 42951	Transistor 2SA970(GR, BL)
QN04	4822 290 83312	IC TA7317P

REF. DESIG.	PART NO.	DESCRIPTION
Q701	4822 130 42951	Transistor 2SA970(GR, BL)
Q702	4822 130 42951	Transistor 2SA970(GR, BL)
Q703	4822 130 43233	Transistor 2SC2240(GR, BL)
Q704	4822 130 43233	Transistor 2SC2240(GR, BL)
Q705	4822 209 83732	IC AN7062P
Q751	4822 130 60526	Transistor 2SD1508
Q752	4822 130 60526	Transistor 2SD1508
Q753	4822 130 43233	Transistor 2SC2240(GR, BL)
Q754	4822 130 43233	Transistor 2SC2240(GR, BL)
Q755	4822 130 42951	Transistor 2SA970(GR, BL)
Q756	4822 130 42951	Transistor 2SA970(GR, BL)
Q757	4822 130 62335	Transistor 2SD2033(E)
Q758	4822 130 62335	Transistor 2SD2033(E)
Q759	4822 130 62334	Transistor 2SB1353(E)
Q760	4822 130 62334	Transistor 2SB1353(E)
▲ Q761	4822 130 61319	Transistor 2SC3181(R, O)
	4822 130 61747	Transistor 2SC3182N(R, O)
▲ Q762	4822 130 61319	Transistor 2SC3181(R, O)
	4822 130 61747	Transistor 2SC3182N(R, O)
▲ Q763	4822 130 43018	Transistor 2SA1264(R, O)
	4822 130 61746	Transistor 2SA1265N(R, O)
▲ Q764	4822 130 43018	Transistor 2SA1264(R, O)
	4822 130 61746	Transistor 2SA1265N(R, O)
Q801	4822 130 43311	Transistor 2SC3298(O, Y)
Q802	4822 130 43023	Transistor 2SA1306(O, Y)
P701-MISCELLANEOUS		
JW51	4822 290 60837	Terminal, Speaker
		[/00B/01B/05B/07B/10B/11B/15B/17B]
JW51	4822 290 60841	Terminal, Speaker /02B/12B
JW52	4822 290 60836	Terminal, Speaker
		[/00B/01B/05B/07B/10B/11B/15B/17B]
JW52	4822 290 60839	Terminal, Speaker /02B/12B
LN01	4822 280 20197	Relay, DH2SU
LN02	4822 280 20197	Relay, DH2SU
		/00B/01B/02B/05B/07B
L751	4822 157 51739	Coil, Speaker
L752	4822 157 51739	Coil, Speaker
P901-POWER SWITCH CIRCUIT BOARD		
▲ F902	4822 253 30191	Fuse 5A 250V
		/00B/02B/05B/07B
▲ G901	4822 121 43732	Film Cap. 0.01 μ F $\pm 20\%$
▲ G902	4822 122 33276	Ceramic Cap. 0.01 μ F $\pm 20\%$
		/05B/15B
▲ J903	4822 264 30313	Jack, AC Outlet /01B
▲ S901	4822 276 11654	Push Switch, Power

NOTE ON SAFETY:

Symbol ▲ Fire or electrical shock hazard. Only original parts should be used to replace any part marked with symbol ▲. Any other component substitution (other than original type), may increase risk of fire or electrical shock hazard.