

Service Manual

74PM47/01B/02B/05B
74PM57/01B/02B/05B

Integrated Stereo Amplifier

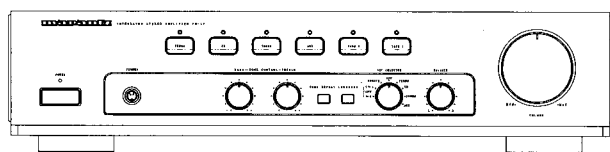

PM-47

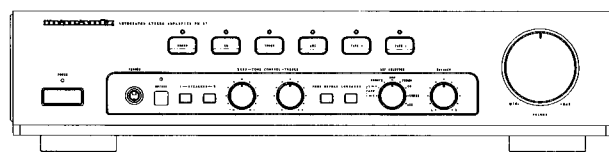

PM-57

TABLE OF CONTENTS

SECTION	PAGE
1. TECHNICAL SPECIFICATIONS	1
2. ADJUSTMENT	2
3. BLOCK DIAGRAM	3
4. WIRING DIAGRAM	5
5. SCHEMATIC DIAGRAM AND PARTS LOCATION (Pattern Side)	7
6. EXPLODED VIEW AND PARTS LIST	15
7. ELECTRICAL PARTS LIST	21

Please use this service manual with referring to the user guide (D.F.U) without fail.

marantz®

model PM-47/PM-57

MARANTZ DESIGN AND SERVICE

Using superior design and selected high grade components, **MARANTZ** company has created the ultimate in stereo sound. Only original **MARANTZ** parts can insure that your **MARANTZ** product will continue to perform to the specifications for which it is famous.

Parts for your **MARANTZ** equipment are generally available to our National Marantz Subsidiary or Agent.

ORDERING PARTS:

Parts can be ordered either by mail or by Fax.. In both cases, the correct part number has to be specified.

The following information must be supplied to eliminate delays in processing your order:

1. Complete address
2. Complete part numbers and quantities required
3. Description of parts
4. Model number for which part is required
5. Way of shipment
6. Signature: any order form or Fax, must be signed, otherwise such part order will be considered as null and void.

USA

MARANTZ AMERICA, INC.
440 MEDINAH ROAD
ROSELLE, ILLINOIS 60172-2330
USA
PHONE : 708-307-3100
FAX : 708-307-2687

CANADA

LENBROOK INDUSTRIES LIMITED
633 GRANITE COURT,
PICKERING, ONTARIO L1W 3K1
CANADA
PHONE : 416-831-6333
FAX : 416-831-6936

EUROPE

MARANTZ EUROPE B.V.
P.O. BOX 80002
BUILDING SFF2
5600 JB EINDHOVEN
THE NETHERLANDS
PHONE : +31-40-2732241
FAX : +31-40-2735578

PROFESSIONAL USA

SUPERSCOPE TECHNOLOGIES, INC.
MARANTZ PROFESSIONAL PRODUCTS
1000 CORPORATE BLVD., SUITE D
AURORA, ILLINOIS 60504 USA
PHONE : 708-820-4800
FAX : 708-820-8103

PROFESSIONAL CANADA

TC ELECTRONICS CANADA LTD
540 FIRING AVE.
BAIE D'URFÉ, QUEBEC H9X 3T2
CANADA
PHONE : 514-457-4044
FAX : 514-457-5524

TRADING

MARANTZ EUROPE B.V.
P.O. BOX 80002
BUILDING SFF2
5600 JB EINDHOVEN
THE NETHERLANDS
PHONE : +31-40-2732241
FAX : +31-40-2735578

AUSTRALIA

MARANTZ AUSTRALIA
3 Figtree Drive
Australia Centre
Homebush, NSW2140 AUSTRALIA
PHONE : +61 2 742.8311
FAX : +61 2 7643074

HONG-KONG

FORWARD INTERNATIONAL CORP. LTD.
15 TH FLOOR, REGENT CENTRE,
88 QUEEN'S ROAD, CENTRAL, H. K.
PHONE : +852 521-0883
FAX : +852 521-7835

THAILAND

MRZ STANDARD CO., LTD.
746-750 WANGBURAPA BANGKOK
10200 THAILAND
PHONE : +66 2222 9181
FAX : +66 2225 8871

TAIWAN

PAI-YUING CO., LTD.
6 TH FL NO. 148 SUNG KIANG RORD,
TAIPEI, 10429, TAIWAN R.O.C.
PHONE : +886 (2) 5221304-8
FAX : +886 (2) 5630415

MALAYSIA

WO KEE HONG ELECTRONICS SDN. BHD.
NO. 102 JALAN SS 21/35, DAMANSARA
UTAMA, 47400 PETALING JAYA
SELANGOR DARUL EHSAN,
MALAYSIA
PHONE : +60 3-7184666
FAX : +60 3-7173828

SINGAPORE

FORWARD MARKETING (SINGAPORE) PTE. LTD.
29, LENG KEE ROAD
SINGAPORE 159099,
PHONE : +65 475-4555
FAX : +65 475-8623

JAPAN-Technical

MARANTZ JAPN INC.
35-1, 7-chome, Sagamiono
Sagamihara-shi, Kanagawa
Japan
PHONE : +81 427 48 2181
FAX : +81 427 48 0889

日本マランツ株式会社

本社 〒228 神奈川県相模原市相模大野7丁目35番1号
営業本部 〒150 東京都渋谷区恵比寿南1丁目11番9号

SHOCK, FIRE HAZARD SERVICE TEST:

CAUTION: After servicing this appliance and prior to returning to customer, measure the resistance between either primary AC cord connector pins (with unit NOT connected to AC mains and its Power switch ON), and the face or Front Panel of product and controls and chassis bottom.

Any resistance measurement less than 1 Megohms should cause unit to be repaired or corrected before AC power is applied, and verified before it is return to the user/customer.

Ref. UL Standard NO.1492.

In case of difficulties, do not hesitate to contact the Technical Department at above mentioned address.

1. TECHNICAL SPECIFICATIONS

	PM-47	PM-57
Power output		
RMS 8 Ohms/4 Ohms (20 Hz - 20 kHz).....	40 / 60 W	50 / 70 W
DIN 8 Ohms 14 Ohms.....	45 / 65 W	55 / 75 W
IHF dynamic power		
8 Ohms 4 Ohms.....	70 / 90 W	80 / 110 W
THD at 8 Ohms RMS rated output.....	0.008%	0.008%
Intermodulation distortion.....	0.008%	0.008%
Dam ping factor.....	60	60
Magnetic cartridge input		
Input sensitivity impedance.....	2.5 mV / 47 k ohms	2.5 mV / 47 k ohms
Accuracy of frequency response to RIAA.....	0.5 dB	0.5 dB
Signal to noise ratio.....	86 dB	86 dB
Tuner / CD / Aux / Tape inputs		
Input sensitivity impedance.....	150 mV / 20 k ohms	150 mV / 20 k ohms
Signal to noise ratio.....	96 dB	96 dB
Frequency response (-1 dB).....	10 - 50 kHz	10 - 50 kHz
Tone characteristic (100 Hz and 10 kHz).....	±6 dB	±6 dB
Channel separation.....	80 dB	80 dB
General		
Power Requirements		
/ 01 version (4 voltages).....	110/120/220/240 V AC, 50/60 Hz	110/120/220/240 V AC, 50/60 Hz
/ 02 / 05 version.....	230 V AC, 50 Hz	230 V AC, 50 Hz
Dimensions		
Panel Width.....	439 mm	439 mm
Panel Height.....	103 mm	103 mm
Depth.....	340 mm	340 mm
Weight		
Unit alone.....	5.4 kg	5.4 kg

Specifications subject to change without prior notice.

2. ADJUSTMENT

IDLING CURRENT ADJUSTMENT

Setting: Mid-position for Tone (Bass & Treble) and Balance
 Minimum position for Volume
 OFF position for Loudness & Tone defeat

Adjust	Measured across	Voltmeter reading *
3295	3309	14mv
3296	3310	14mv

*Adjustment should be done after switch on the set for 5 minutes.

PM-47/57 BLOCK DIAGRAM

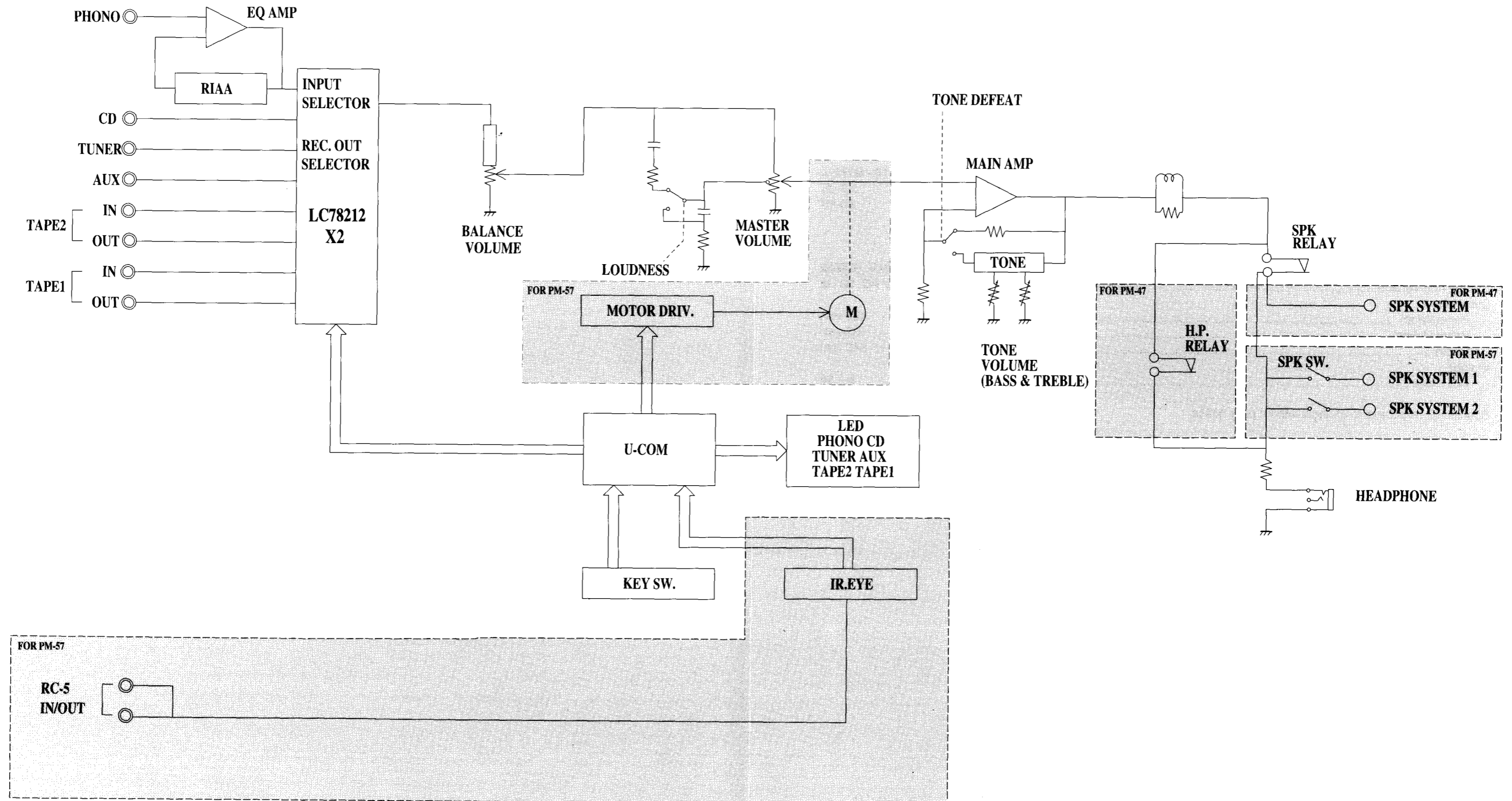

PM-47/57 WIRING DIAGRAM

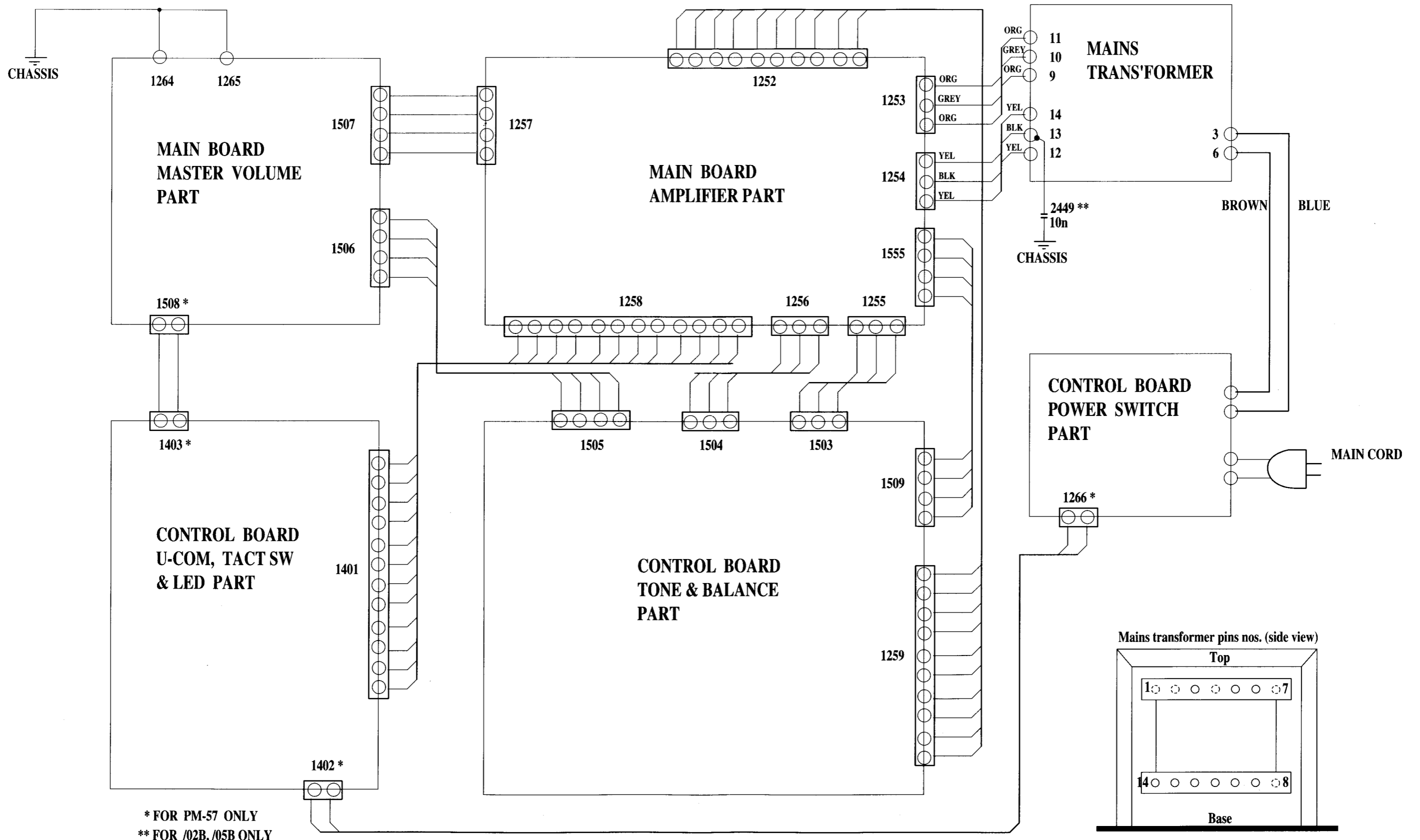

* FOR PM-57 ONLY
 ** FOR /02B, /05B ONLY

5. SCHEMATIC DIAGRAM AND PARTS LOCATION (Pattern Side)

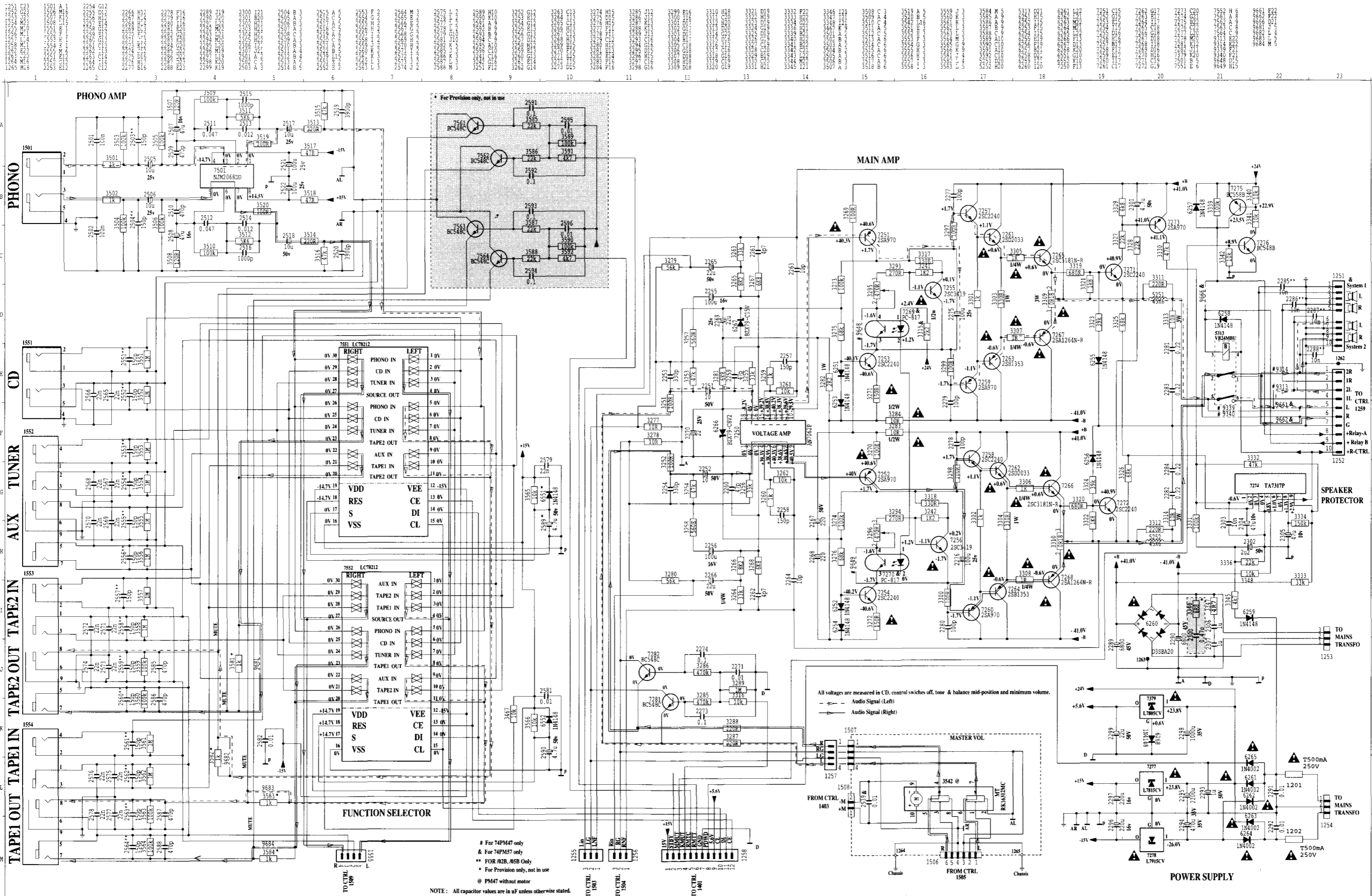

1 2 3 4 5 6 7 8 9

PM47/PM57/PW1-P1-960507-1 spcs
3139 113 33352

A
B
C
D
E
F

PM47/57/PW1
3139 113 33352
flow direction

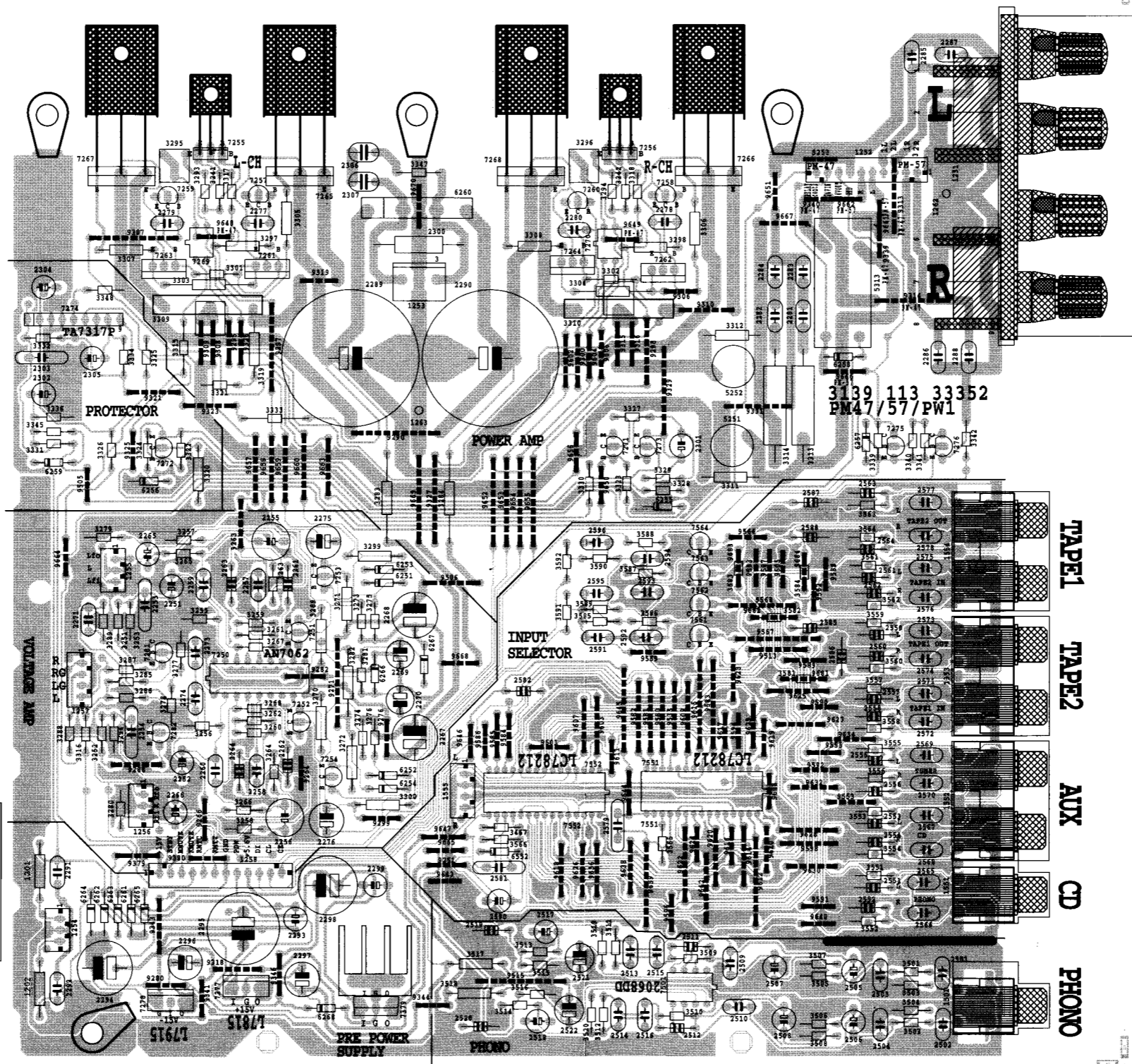
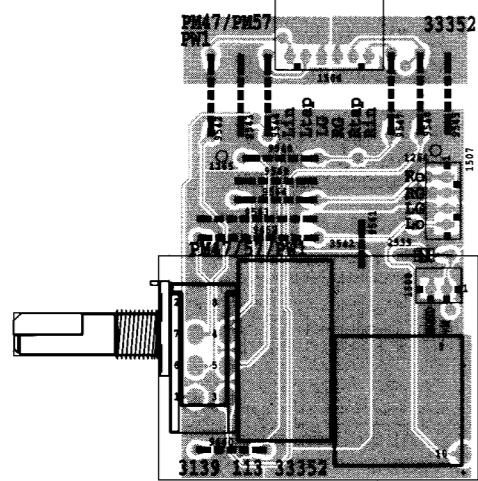

1251 A 9	2519 F 6	3300 E 5	5251 C 7	9339 B 8	9653 C 6
1252 A 8	2520 F 6	3301 B 4	5252 C 7	9340 A 8	9654 C 6
1253 B 5	2521 F 6	3302 B 6	5313 B 8	9341 F 4	9655 C 6
1254 F 3	2522 F 6	3303 B 4	6251 D 5	9343 P 3	9656 C 6
1255 D 3	2539 E 2	3304 B 6	6252 E 5	9344 F 5	9657 C 4
1256 E 3	2551 F 8	3305 B 4	6253 D 5	9346 F 4	9658 C 4
1257 E 3	2552 F 8	3306 B 7	6254 E 5	9379 F 3	9659 C 4
1258 F 4	2553 E 8	3307 B 3	6255 C 7	9380 F 4	9660 C 4
1262 A 9	2554 F 8	3308 B 6	6256 C 3	9460 F 1	9661 B 8
1263 C 5	2555 E 8	3309 B 4	6257 C 8	9462 E 1	9662 A 8
1264 E 2	2556 E 8	3310 B 6	6258 B 8	9505 C 3	9663 C 5
1265 E 1	2557 E 8	3311 C 7	6259 C 3	9506 D 5	9664 D 3
1501 F 9	2558 E 8	3312 B 7	6260 B 5	9513 D 7	9665 F 5
1506 D 2	2559 D 8	3313 C 8	6261 F 3	9515 F 6	9666 C 8
1507 E 2	2560 D 8	3314 C 7	6262 F 3	9533 E 7	9667 B 7
1508 E 2	2561 D 8	3315 B 4	6263 F 3	9542 E 1	9668 D 5
1551 F 9	2562 D 8	3316 E 3	6264 F 3	9543 E 1	9669 C 5
1552 E 9	2563 C 8	3317 A 4	6265 F 3	9544 E 2	9670 A 5
1553 E 9	2564 D 8	3318 A 7	6266 D 5	9545 E 2	9681 E 8
1554 D 9	2565 F 8	3319 B 4	6267 D 5	9546 E 2	9682 D 7
1555 E 5	2566 F 8	3320 C 4	6268 F 5	9547 E 2	9683 D 7
2251 D 4	2567 E 8	3321 C 4	6269 F 6	9548 E 2	9684 D 8
2252 E 4	2568 F 8	3322 C 4	7250 E 4	9549 E 2	
2253 D 3	2569 E 8	3323 C 6	7251 D 4	9553 E 8	
2254 E 3	2570 E 8	3324 C 3	7252 E 4	9555 E 8	
2255 D 4	2571 E 8	3325 C 3	7253 D 5	9561 E 2	
2256 E 4	2572 E 8	3326 C 3	7254 E 5	9562 D 8	
2257 D 4	2573 D 8	3327 C 7	7255 A 4	9563 E 1	
2258 E 4	2574 D 8	3328 C 7	7256 A 6	9564 E 2	
2259 D 4	2575 D 8	3329 C 7	7257 A 4	9566 D 7	
2260 E 4	2576 D 8	3330 C 6	7258 A 7	9567 D 7	
2261 D 4	2577 C 8	3331 C 3	7259 A 4	9568 D 7	
2262 E 4	2578 D 8	3332 B 3	7260 A 6	9569 D 7	
2263 D 4	2579 E 6	3333 C 4	7261 B 4	9580 E 7	
2264 E 4	2581 F 6	3334 B 3	7262 B 7	9581 E 7	
2265 D 3	2582 E 6	3336 C 3	7263 B 4	9582 E 7	
2266 E 4	2585 D 8	3339 C 8	7264 B 6	9583 E 7	
2267 E 5	2586 D 8	3340 C 8	7265 A 4	9584 E 6	
2268 D 5	2587 C 8	3341 C 8	7266 A 7	9585 E 6	
2269 D 5	2588 D 8	3342 C 9	7267 A 3	9586 E 6	
2270 E 5	2590 F 6	3343 F 3	7268 A 6	9587 D 7	
2271 D 3	2591 D 6	3344 F 3	7269 B 4	9588 D 8	
2273 D 4	2592 D 7	3345 C 3	7270 B 6	9589 D 8	
2274 E 4	2593 D 7	3347 A 5	7271 C 6	9590 E 8	
2275 D 5	2594 D 7	3348 B 3	7272 C 3	9591 F 8	
2276 E 5	2595 D 6	3467 E 6	7273 C 7	9592 E 8	
2277 B 4	2596 D 6	3501 F 8	7274 B 3	9593 D 7	
2278 B 7	3241 A 4	3502 F 8	7275 C 8	9594 E 7	
2279 B 4	3242 A 6	3503 F 8	7276 C 8	9596 F 7	
2280 B 6	3251 D 3	3504 F 8	7277 F 4	9598 F 8	
2281 B 8	3252 E 3	3505 F 8	7278 F 4	9601 E 6	
2282 B 7	3253 D 3	3506 F 8	7281 D 3	9602 B 6	
2283 B 8	3254 C 3	3507 F 8	7282 E 3	9603 E 6	
2284 F 7	3255 D 4	3508 F 8	7379 F 5	9604 B 6	
2285 A 8	3256 E 4	3509 F 7	7501 F 7	9605 D 7	
2286 B 8	3257 D 4	3510 F 7	7551 E 7	9606 B 6	
2287 A 9	3258 A 4	3511 F 6	7552 E 6	9607 E 6	
2288 B 9	3259 D 4	3512 F 6	7561 D 7	9608 E 7	
2289 B 5	3260 E 4	3513 F 6	7562 D 7	9609 E 7	
2290 B 6	3261 D 4	3514 F 6	7563 D 7	9610 F 7	
2291 F 3	3262 A 4	3515 F 6	7564 D 7	9611 E 6	
2292 F 3	3263 D 4	3516 F 6	9251 F 5	9612 F 7	
2293 F 4	3264 A 4	3517 F 6	9253 A 8	9614 F 7	
2294 F 3	3265 D 4	3518 F 5	9263 D 4	9615 E 7	
2295 F 4	3266 A 4	3519 F 6	9264 E 4	9616 F 7	
2296 F 4	3267 D 4	3520 F 6	9266 E 4	9617 E 7	
2297 F 4	3268 E 4	3542 F 2	9271 E 5	9618 F 6	
2298 F 5	3269 D 5	3551 F 8	9276 E 5	9619 F 7	
2299 F 5	3270 E 5	3552 F 8	9280 F 4	9620 F 7	
2300 B 5	3271 D 5	3553 E 8	9282 E 4	9622 F 7	
2301 C 7	3272 E 5	3554 F 8	9288 E 3	9623 F 7	
2302 C 3	3273 D 5	3555 E 8	9290 C 5	9624 F 7	
2303 B 3	3274 E 5	3556 E 8	9295 B 4	9625 E 8	
2304 B 3	3275 D 5	3557 E 8	9297 B 4	9626 F 6	
2305 B 3	3276 E 5	3558 E 8	9298 F 7	9627 E 8	
2306 A 5	3277 D 4	3559 D 8	9299 E 5	9628 E 8	
2307 A 5	3278 E 4	3560 D 8	9300 B 6	9629 E 7	
2501 F 9	3279 D 3	3561 D 8	9306 B 7	9630 F 8	
2502 F 9	3280 C 3	3562 D 8	9307 B 3	9632 E 8	
2503 F 8	3281 D 5	3563 C 8	9308 B 4	9634 E 8	
2504 F 8	3282 E 5	3564 D 8	9309 B 4	9636 F 6	
2505 F 8	3283 C 5	3565 F 7	9310 B 7	9638 F 6	
2506 F 8	3284 C 5	3566 F 6	9313 A 8	9639 F 7	
2507 F 7	3285 E 3	3581 E 8	9314 B 8	9640 F 8	
2508 F 7	3286 E 3	3582 D 7	9315 B 6	9642 F 7	
2509 F 7	3287 D 3	3583 D 7	9316 B 7	9643 F 5	
2510 F 7	3288 E 3	3584 D 8	9318 F 4	9644 E 6	
2511 F 7	3289 D 3	3585 D 6	9319 B 4	9645 E 6	
2512 F 7	3293 A 4	3586 D 7	9321 C 3	9646 E 5	
2513 F 6	3294 A 4	3587 D 7	9323 C 4	9647 F 5	
2514 F 6	3295 A 4	3588 D 7	9325 C 3	9648 B 4	
2515 F 7	3296 A 4	3589 D 6	9326 B 4	9649 B 6	
2516 F 7	3297 B 4	3590 D 6	9327 C 5	9650 C 6	
2517 F 6	3298 B 7	3591 D 6	9329 C 7	9651 A 7	
2518 F 6	3299 D 5	3592 D 6	9331 C 7	9652 C 6	

This assembly drawing shows a summary of all possible versions.
For components used in a specific version see schematic diagram and respective parts list.

1 2 3 4 5 6 7 8 9

CONTROL BOARD

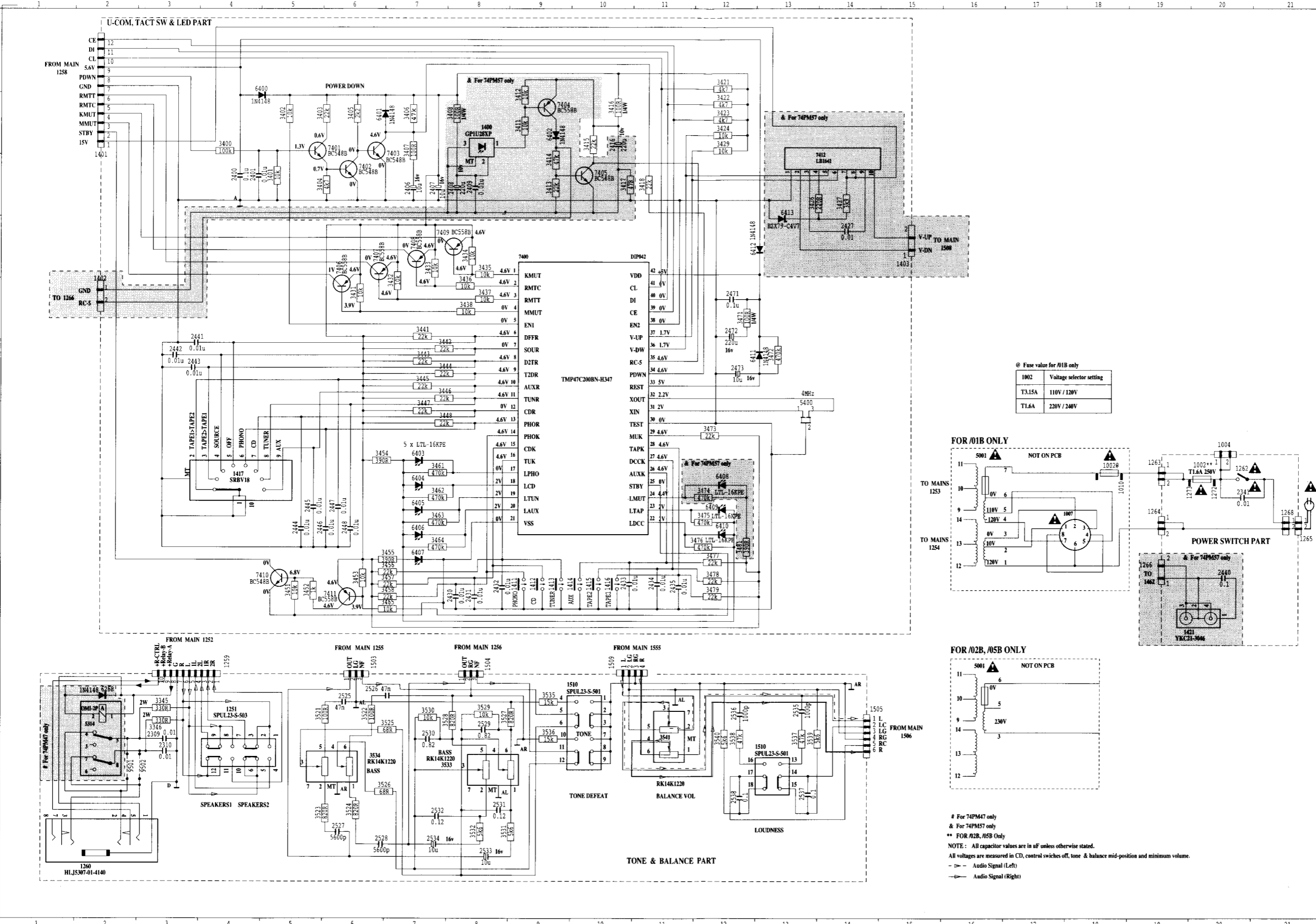

1001	H18	3535	L K 9
1002	H19	3536	L K 8
1003	H20	3537	L K 7
1004	G20	3538	L K 6
1005	F20	3539	L K 5
1006	E20	3540	L K 4
1007	D20	3541	L K 3
1008	C20	3542	L K 2
1009	B20	3543	L K 1
1010	A20	3544	L K 0
1011	H17	3545	L K 9
1012	H18	3546	L K 8
1013	H19	3547	L K 7
1014	H20	3548	L K 6
1015	G20	3549	L K 5
1016	F20	3550	L K 4
1017	E20	3551	L K 3
1018	D20	3552	L K 2
1019	C20	3553	L K 1
1020	B20	3554	L K 0
1021	A20	3555	L K 9
1022	H17	3556	L K 8
1023	H18	3557	L K 7
1024	H19	3558	L K 6
1025	H20	3559	L K 5
1026	G20	3560	L K 4
1027	F20	3561	L K 3
1028	E20	3562	L K 2
1029	D20	3563	L K 1
1030	C20	3564	L K 0
1031	B20	3565	L K 9
1032	A20	3566	L K 8
1033	H17	3567	L K 7
1034	H18	3568	L K 6
1035	H19	3569	L K 5
1036	H20	3570	L K 4
1037	G20	3571	L K 3
1038	F20	3572	L K 2
1039	E20	3573	L K 1
1040	D20	3574	L K 0
1041	C20	3575	L K 9
1042	B20	3576	L K 8
1043	A20	3577	L K 7
1044	H17	3578	L K 6
1045	H18	3579	L K 5
1046	H19	3580	L K 4
1047	H20	3581	L K 3
1048	G20	3582	L K 2
1049	F20	3583	L K 1
1050	E20	3584	L K 0
1051	D20	3585	L K 9
1052	C20	3586	L K 8
1053	B20	3587	L K 7
1054	A20	3588	L K 6

1 2 3 4 5 6 7 8 9

pm47/ctrl-p2-960506-1 spcs
3139 113 33342

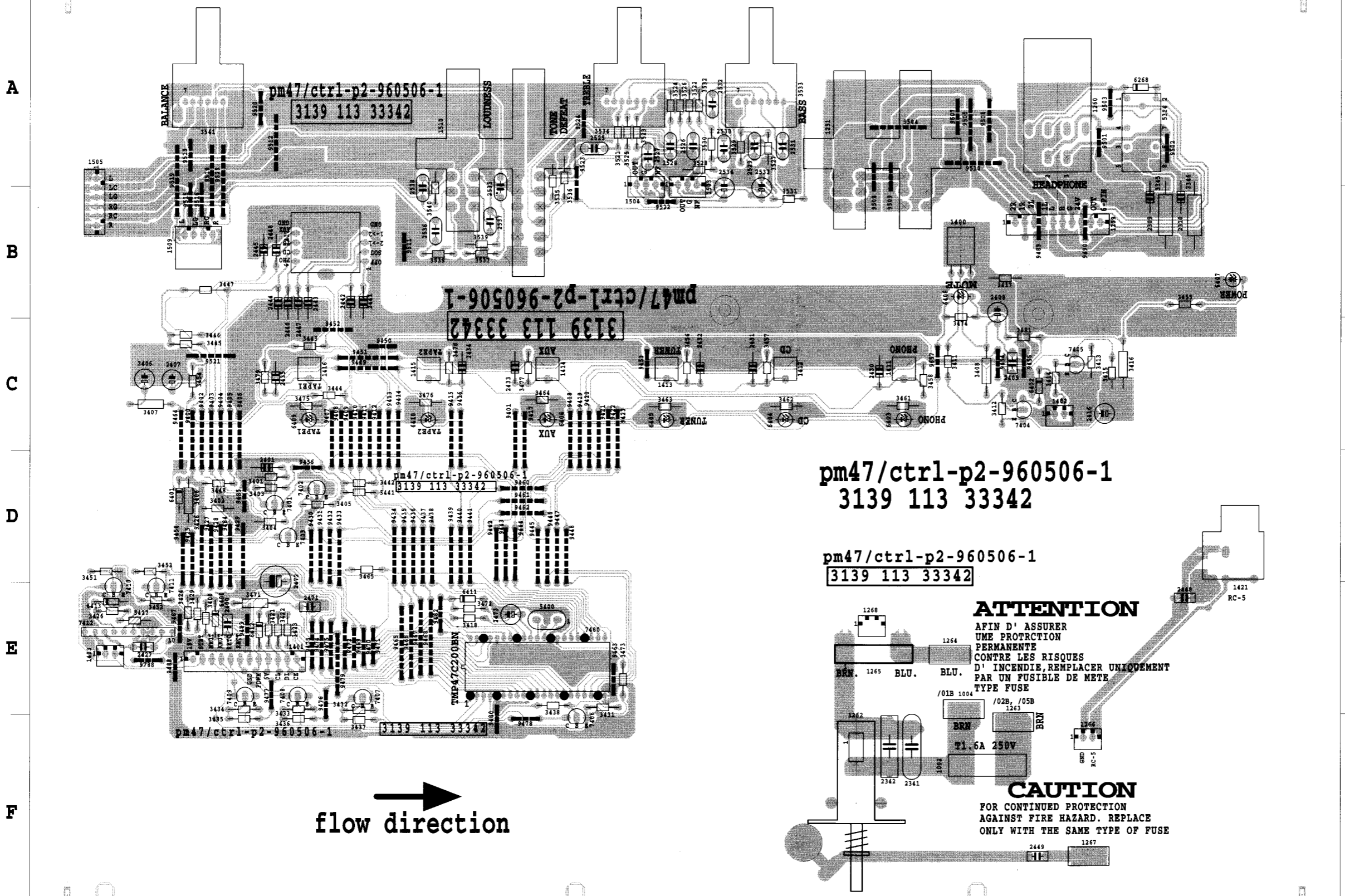

pm47/ctrl-p2-960506-1
3139 113 33342

pm47/ctrl-p2-960506-1
3139 113 33342

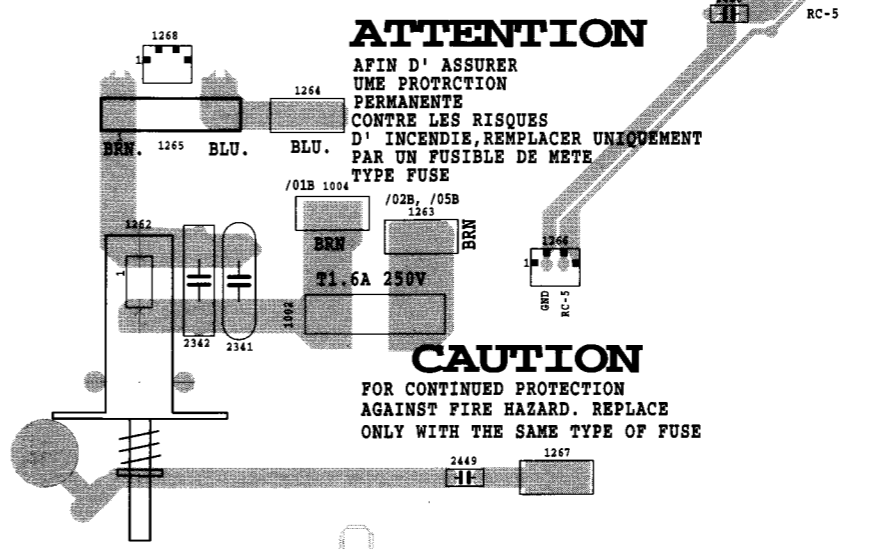

ATTENTION

AFIN D' ASSURER
UNE PROTECTION
PERMANENTE
CONTRE LES RISQUES
D' INCENDIE, REMPLACER UNIQUEMENT
PAR UN FUSIBLE DE METE
TYPE FUSE

CAUTION

FOR CONTINUED PROTECTION
AGAINST FIRE HAZARD. REPLACE
ONLY WITH THE SAME TYPE OF FUSE

→
flow direction

1002 F 7	3423 E 2	9400 C 1	9510 A 7
1004 E 7	3424 E 1	9401 C 4	9511 B 3
1251 B 6	3426 E 1	9402 C 1	9512 A 2
1259 B 8	3427 E 1	9403 C 1	9513 A 1
1260 A 8	3429 E 1	9404 C 1	9515 B 1
1262 F 6	3431 E 4	9405 C 2	9516 B 1
1263 F 7	3432 E 3	9406 C 2	9518 A 1
1264 E 7	3433 E 2	9407 C 2	9519 A 1
1265 E 6	3434 E 2	9408 C 2	9520 A 2
1266 F 8	3435 F 2	9409 C 2	9521 C 1
1267 F 8	3436 F 2	9410 C 3	9522 B 5
1268 E 6	3437 F 3	9411 C 3	9523 A 4
1400 B 7	3438 E 4	9412 C 3	9524 A 4
1401 E 2	3441 D 3	9413 C 3	9525 A 2
1402 C 8	3442 D 3	9414 C 3	9657 C 7
1403 E 1	3443 C 2	9415 C 3	9788 E 1
1411 C 7	3444 C 2	9416 C 3	
1412 C 6	3445 C 1	9417 C 4	
1413 C 5	3446 C 1	9418 C 4	
1414 C 4	3447 B 1	9419 C 4	
1415 C 3	3448 D 1	9420 C 4	
1416 C 2	3451 D 1	9421 C 4	
1417 B 2	3452 E 1	9422 C 4	
1421 D 9	3453 D 1	9423 C 4	
1503 A 5	3454 C 1	9425 D 1	
1504 A 5	3455 B 9	9426 D 1	
1505 B 1	3456 C 5	9427 D 1	
1509 B 1	3457 C 6	9428 D 1	
1510 B 4	3458 C 7	9429 D 2	
2309 B 9	3461 C 7	9430 D 2	
2310 B 9	3462 C 6	9431 D 2	
2341 F 7	3463 C 5	9432 D 2	
2342 F 7	3464 C 4	9433 D 2	
2400 E 2	3465 D 3	9434 D 3	
2401 D 2	3471 E 2	9435 D 3	
2406 C 1	3472 E 3	9436 D 3	
2407 C 1	3473 E 5	9437 D 3	
2408 B 7	3474 B 7	9438 D 3	
2409 C 7	3475 C 2	9439 D 3	
2416 C 8	3476 C 3	9440 D 3	
2427 E 1	3477 C 4	9441 D 3	
2430 C 6	3478 C 3	9442 D 4	
2431 C 6	3479 C 2	9443 D 4	
2432 C 5	3481 C 8	9444 D 4	
2433 C 4	3521 A 4	9445 D 4	
2434 C 3	3522 A 5	9446 D 4	
2435 C 2	3523 A 5	9447 D 4	
2440 E 9	3524 A 5	9448 D 4	
2441 B 3	3525 A 5	9449 C 3	
2442 B 2	3526 A 5	9450 C 3	
2443 B 2	3527 A 6	9451 C 3	
2444 B 2	3528 A 5	9452 C 2	
2445 B 2	3529 A 5	9453 C 5	
2446 B 2	3530 A 5	9454 C 7	
2447 B 2	3531 B 6	9455 C 8	
2448 B 2	3532 A 5	9456 D 2	
2449 F 8	3533 A 6	9458 D 1	
2471 E 2	3534 A 5	9460 D 4	
2472 D 2	3535 A 4	9461 D 4	
2473 E 4	3536 A 4	9462 D 4	
2525 A 4	3537 B 3	9463 E 4	
2526 A 5	3538 B 3	9464 C 1	
2527 A 5	3539 B 3	9465 E 3	
2528 A 5	3540 B 3	9466 E 3	
2529 A 6	3541 A 1	9467 E 3	
2530 A 5	5314 A 8	9468 E 3	
2531 A 6	5400 E 4	9469 E 2	
2532 A 5	6268 A 8	9470 E 3	
2533 B 6	6400 E 1	9471 E 3	
2534 B 5	6401 D 1	9472 E 2	
2535 B 4	6402 C 8	9473 E 2	
2536 B 3	6403 C 7	9474 E 2	
2537 B 4	6404 C 6	9475 E 2	
2538 B 3	6405 C 5	9476 E 2	
3345 B 9	6406 C 4	9477 E 2	
3346 B 9	6407 B 9	9478 F 4	
3400 E 1	6408 B 7	9479 E 2	
3401 D 2	6409 C 2	9480 F 4	
3402 D 1	6410 C 3	9482 E 3	
3403 D 2	6411 E 3	9483 E 2	
3404 D 2	6412 E 2	9484 D 2	
3405 D 2	6413 E 1	9485 D 2	
3406 D 1	7400 E 4	9487 E 1	
3407 C 1	7401 D 2	9488 E 1	
3408 C 7	7402 D 2	9489 B 8	
3411 C 7	7403 D 2	9490 B 8	
3412 C 7	7404 C 8	9501 A 8	
3413 C 8	7405 C 8	9502 A 9	
3414 C 8	7406 F 4	9503 A 8	
3415 C 8	7407 E 3	9504 A 7	
3416 C 8	7408 E 2	9505 A 7	
3417 B 7	7409 E 2	9506 A 7	
3418 E 3	7410 E 1	9507 A 7	
3421 E 2	7411 E 1	9508 A 6	
3422 E 2	7412 E 1	9509 A 7	

This assembly drawing shows a summary of all possible versions.
For components used in a specific version see schematic diagram and respective parts list.

1 2 3 4 5 6 7 8 9

6. EXPLODED VIEW AND PARTS LIST

For PM-47

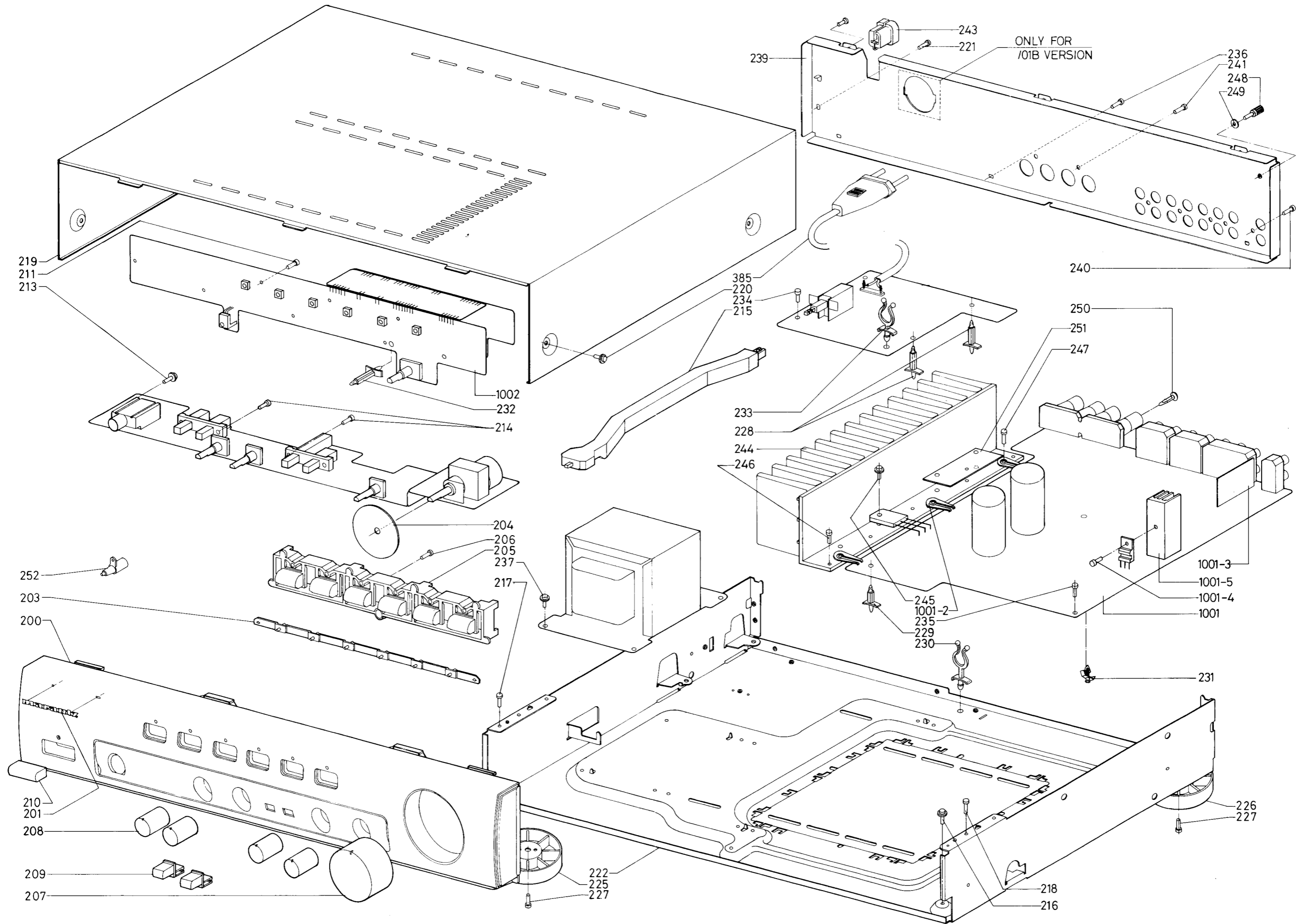

PARTS LIST FOR PM-47

(VERS. :VERSION, U:U.S.A., F:JAPAN, K:FAR EAST, **:EUROPE)

POS. NO	VERS. COLOR	PART NO. (FOR EUROPE)	DESCRIPTION	PART NO. (USA/JPN)
200		4822 459 04198	FRONT CABINET	QP45904198
201		4822 454 12948	MARANTZ BADGE	QP45412948
203		4822 466 11148	LIGHT GUIDE LED	QP46611148
205		4822 410 10558	BUTTON - SET FUNCTION	QP41010558
207		4822 410 10559	VOLUME KNOB	QP41010559
208		4822 410 10561	KNOB	QP41010561
209		4822 410 10562	BUTTON PUSH/PUSH	QP41010562
210		4822 462 72053	POWER BUTTON	QP46272053
225		4822 462 42129	LEG - GOLD	QP46242129
226		4822 462 42131	LEG - GOLD	QP46242131
▲ 243		4822 532 60948	BUSH	QP53260948
248		4822 502 13921	SCREW - PHONO GND	QP50213921
252		4822 466 11149	LIGHT GUIDE POWER	QP46611149
385	01B/02B	4822 321 10781	MAINS CORD	QP32110781
▲ 385	05B	4822 321 10941	MAIN CORD UK	QP32110941
387		4822 736 14443	INSTRUCTION FOR USE	QP73614443
▲ 391	01B	4822 263 21092	ADAPTOR PLUG 6A 250V	QP26321092
▲ 392	01B	4822 070 33152	FUSE T3.15A IEC 250V	QP07033152
▲ 1007	01B	4822 273 10317	VOLTAGE SELECTOR	QP27310317
▲ 1010	01B	4822 256 30233	FUSE HOLDER	QP25630233
2449	02B/05B	4822 122 33307	10nF 5% 50V	QP12233307
▲ 5001	01B	4822 146 10506	MAINS TRANSFORMER OVS	QP14610506
▲ 5001	02B/05B	4822 146 10517	MAINS TRANSFORMER IEC	QP14610517

PARTS LIST FOR PM-57

(VERS. :VERSION, U:U.S.A., F:JAPAN, K:FAR EAST, **:EUROPE)

POS. NO	VERS. COLOR	PART NO. (FOR EUROPE)	DESCRIPTION	PART NO. (USA/JPN)
200		4822 459 04212	FRONT CABINET	QP45904212
201		4822 454 12948	MARANTZ BADGE	QP45412948
203		4822 466 11148	LIGHT GUIDE LED	QP46611148
205		4822 410 10558	BUTTON - SET FUNCTION	QP41010558
207		4822 410 10559	VOLUME KNOB	QP41010559
208		4822 410 10561	KNOB	QP41010561
209		4822 410 10562	BUTTON PUSH/PUSH	QP41010562
210		4822 462 72053	POWER BUTTON	QP46272053
225		4822 462 42129	LEG GOLD	QP46242129
226		4822 462 42131	LEG GOLD	QP46242131
▲ 243		4822 532 60948	BUSH	QP53260948
248		4822 502 13921	SCREW PHONO GND	QP50213921
252		4822 466 11149	LIGHT GUIDE POWER	QP46611149
253		4822 466 11158	LIGHT GUIDE MUTE	QP46611158
254		4822 381 11749	WINDOW REMOTE CONTROL	QP38111749
384		4822 219 10067	REMOTE CONTROL RC040	QP21910067
385	01B/02B	4822 321 10781	MAINS CORD	QP32110781
▲ 385	05B	4822 321 10941	MAINS CORD UK	QP32110941
387		4822 736 14443	INSTRUCTION FOR USE	QP73614443
▲ 391	01B	4822 263 21092	ADAPTOR PLUG 6A 250V	QP26321092
▲ 392	01B	4822 070 33152	FUSE T3.15A IEC 250V	QP07033152
▲ 1007	01B	4822 273 10317	VOLTAGE SELECTOR	QP27310317
▲ 1010	01B	4822 256 30233	FUSE HOLDER	QP25630233
2449	02B/05B	4822 122 33307	10nF 5% 50V	QP12233307
▲ 5001	01B	4822 146 10521	MAINS TRANSFORMER OV	QP14610521
▲ 5001	02B/05B	4822 146 10518	MAINS TRANSFORMER IEC	QP14610518

For PM-57

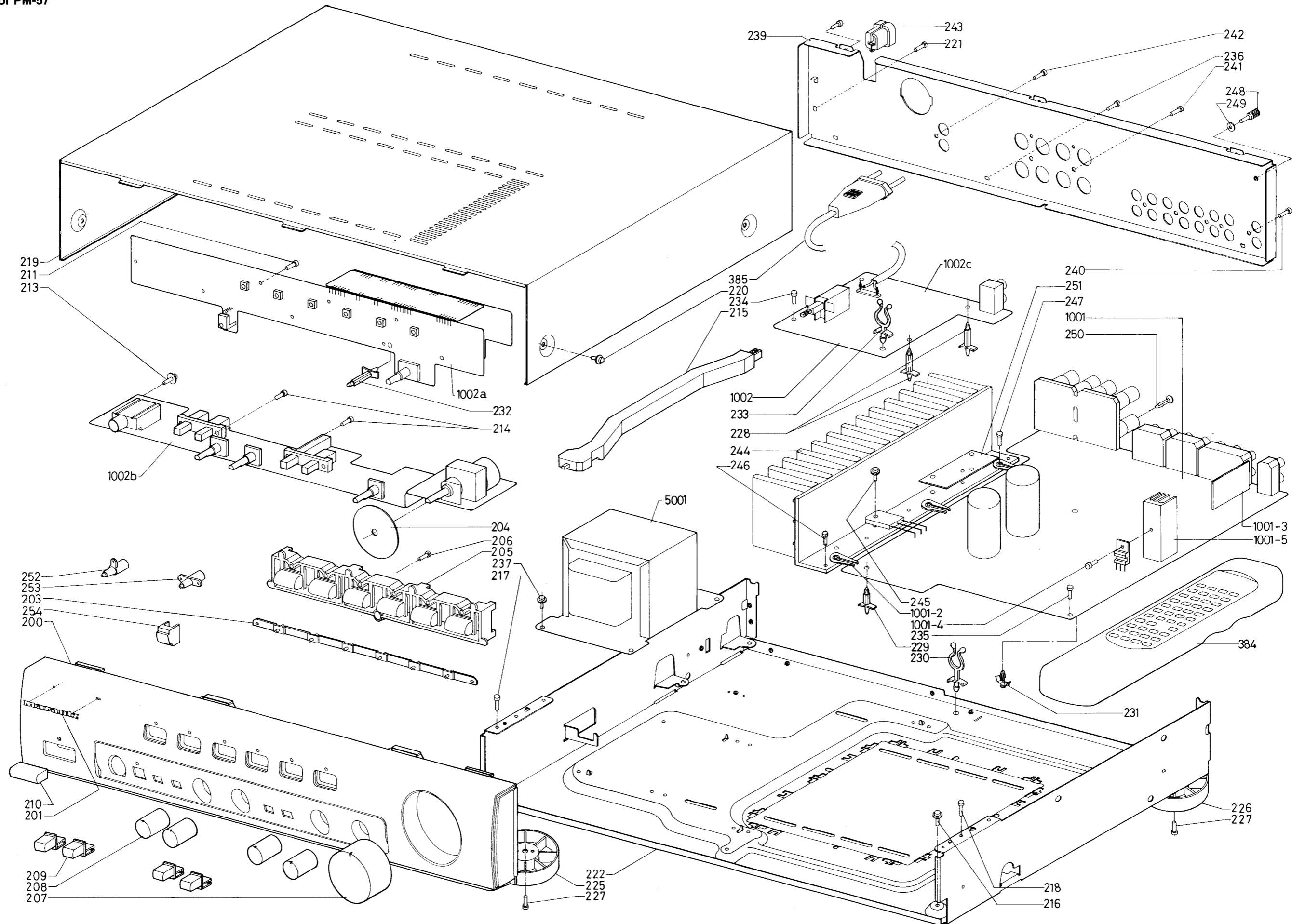

7. ELECTRICAL PARTS LIST

(VERS.:VERSION, U:U.S.A., F:JAPAN, K:FAR EAST, **:EUROPE)

POS. NO	VERS. COLOR	PART NO. (FOR EUROPE)	DESCRIPTION	PART NO. (USA/JPN)
			MAIN BOARD	
			MISCELLANEOUS	
▲ 1201		4822 071 55001	FUSE T500mA 250V	QP07155001
▲ 1202		4822 071 55001	FUSE T500mA 250V	QP07155001
1251	PM47	4822 265 10649	LOUDSPEAKER SOCKET	QP26510649
1251	PM57	4822 265 10655	LOUDSPEAKER SOCKET 8P	QP26510655
1501		4822 265 10654	CINCH SOCKET - PHONO	QP26510654
1552		4822 267 20453	CINCH SOCKET - CDTUNERIALX	QP26720453
1553		4822 267 31452	CINCH SOCKET - TAPE 2	QP26731452
1554		4822 267 31452	CINCH SOCKET - TAPE 1	QP26731452
5251		4822 157 70599	IND. FIXED BEAD	QP15770599
5252		4822 157 70599	IND. FIXED BEAD	QP15770599
5313		4822 280 80764	RELAY 2P 24V 5A	QP28080764
			CAPACITORS	
2251		4822 124 11777	S10µF 25V 20%	QP12411777
2252		4822 124 11777	S10µF 25V 20%	QP12411777
2253		4822 126 10779	330pF 50V	QP12610779
2254		4822 126 10779	330pF 50V	QP12610779
2255		4822 124 11761	100µF 20% 50V	QP12411761
2256		4822 124 11761	100µF 20% 50V	QP12411761
2257		4822 126 13985	150pF 5% 50V	QP12613985
2258		4822 126 13985	150pF 5% 50V	QP12613985
2259		4822 122 31072	47pF 2% 100V	QP12231072
2260		4822 122 31072	47pF 2% 100V	QP12231072
2261		4822 122 10465	4.7pF 10% 50V	QP12210465
2262		4822 122 10465	4.7pF 10% 50V	QP12210465
2263		4822 122 33847	10pF 5%NPO 50V	QP12233847
2264		4822 122 33847	10pF 5%NPO 50V	QP12233847
2265		4822 124 41596	22µF20% 50V	QP12441596
2266		4822 124 41596	22µF20% 50V	QP12441596
2267		5322 124 22094	220µF20% 50V	QQ12422094
2268		5322 124 22094	220µF20% 50V	QQ12422094
2269		4822 124 11778	S22µF 25V 20%	QP12411778
2270		4822 124 11778	S22µF 25V 20%	QP12411778
2271		5322 121 42386	100nF 5% 63V	QQ12142386
2273		5322 121 42386	100nF 5% 63V	QQ12142386
2274		5322 121 42386	100nF 5% 63V	QQ12142386
2275		4822 124 80293	100µF 20% 25V	QP12480293
2276		4822 124 80293	100µF 20% 25V	QP12480293
2277		4822 126 10777	100pF 50V	QP12610777
2280				
2281		4822 121 42408	220nF 5% 63V	QP12142408
2284				
2285	/02B/05B	4822 124 80141	10nF 10% 50V	QP12480141
2288				
2289		4822 124 11504	6800µF 20% 50V	QP12411504
2290		4822 124 11504	6800µF 20% 50V	QP12411504
2291		4822 124 80141	10nF 10% 50V	QP12480141
2292		4822 124 80141	10nF 10% 50V	QP12480141
2293		4822 124 40242	1µF 20% 63V	QP12440242
2294		4822 124 42392	470µF 20% 50V	QP12442392
2295		4822 124 41993	2200µF 20% 35V	QP12441993
2296		4822 124 11779	S220µF 16V 20%	QP12411779
2297		4822 124 11779	S220µF 16V 20%	QP12411779
2298		5322 124 22229	1000µF 20% 35V	QQ12422229
2299		4822 124 41596	22µF 20% 50V	QP12441596
▲ 2301		4822 124 40246	4.7µF 20% 63V	QP12440246

POS. NO	VERS. COLOR	PART NO. (FOR EUROPE)	DESCRIPTION	PART NO. (USA/JPN)
2302		4822 124 41576	2.2µF 20% 50V	QP12441576
2303		4822 124 80141	10nF 10% 50V	QP12480141
2304		4822 124 80196	47µF 20% 50V	QP12480196
2305		4822 124 80196	47µF 20% 50V	QP12480196
2306		4822 121 51319	1µF 10% 63V	QP12151319
2307		4822 121 51319	1µF 10% 63V	QP12151319
2501		5322 121 42386	100nF 5% 63V	QQ12142386
2502		5322 121 42386	100nF 5% 63V	QQ12142386
2503	/02B/05B	4822 126 13985	150pF 5% 50V	QP12613985
2504	/02B/05B	4822 126 13985	150pF 5% 50V	QP12613985
2505		4822 124 11781	S10µF 25V 20%	QP12411781
2506		4822 124 11781	S10µF 25V 20%	QP12411781
2507		4822 124 80196	47µF20% 50V	QP12480196
2508		4822 124 80196	47µF20% 50V	QP12480196
2509		4822 126 10781	470pF 50V	QP12610781
2510		4822 126 10781	470pF 50V	QP12610781
▲ 2511		4822 126 12785	47nF Y5VTUB 50V	QP12612785
▲ 2512		4822 126 12785	47nF Y5VTUB 50V	QP12612785
2513		4822 121 41935	12nF 5% 250V	QP12141935
2514		4822 121 41935	12nF 5% 250V	QP12141935
2515		4822 121 51299	1nF 10% 50V	QP12151299
2516		4822 121 51299	1nF 10% 50V	QP12151299
2517		4822 124 11781	S10µF 25V 20%	QP12411781
2518		4822 124 11781	S10µF 25V 20%	QP12411781
2519		4822 126 13151	3.9nF 10% Y5R 16V	QP12613151
2520		4822 126 13151	3.9nF 10% Y5R 16V	QP12613151
2521		4822 124 80293	100µF20% 25V	QP12480293
2522		4822 124 80293	100µF20% 25V	QP12480293
▲ 2523	PM57	4822 121 51387	10nF 20% 16V	QP12151387
2524		4822 122 33849	150pF 10% Y5P 50V	QP12233849
▲ 2565	/02B/05B	4822 126 12147	22nF10% Y5R 25V	QP12612147
▲ 2579		4822 124 80141	10nF10% 50V	QP12480141
▲ 2581		4822 121 51387	10nF20% 16V	QP12151387
▲ 2582				
2585		4822 122 33519	470pF10% 50V	QP12233519
2588				
▲ 2590		4822 124 40246	4.7µF20% 63V	QP12440246
3241		4822 116 52207	1K2 5% 0.5W	QP11652207
3242		4822 116 52207	1K2 5% 0.5W	QP11652207
3251		4822 116 52175	100E 5% 0.5W	QP11652175
3252		4822 116 52175	100E 5% 0.5W	QP11652175
3253		4822 116 52284	47K 5% 0.5W	QP11652284
3254		4822 116 52284	47K 5% 0.5W	QP11652284
3255		4822 116 52271	33K 5% 0.5W	QP11652271
3256		4822 116 52271	33K 5% 0.5W	QP11652271
3257		4822 116 52226	560E 5% 0.5W	QP11652226
3258		4822 116 52226	560E 5% 0.5W	QP11652226
3259		4822 050 11002	1K00 1% 0.4W	QP05011002
3260		4822 050 11002	1K00 1% 0.4W	QP05011002
3261		4822 116 83864	10K 5% 0.5W	QP11683864
3262		4822 116 83864	10K 5% 0.5W	QP11683864
3263		4822 116 52271	33K 5% 0.5W	QP11652271
3264		4822 116 52271	33K 5% 0.5W	QP11652271
3265		4822 116 52303	8K2 5% 0.5W	QP11652303
3266		4822 116 52303	8K2 5% 0.5W	QP11652303
3267		4822 116 52296	6K8 5% 0.5W	QP11652296
3268		4822 116 52296	6K8 5% 0.5W	QP11652296

(VERS.:VERSION, U:U.S.A., F:JAPAN, K:FAR EAST, **:EUROPE)

POS. NO	VERS. COLOR	PART NO. (FOR EUROPE)	DESCRIPTION	PART NO. (USA/JPN)
▲ 3269		4822 052 10101	100R00 5% 0.33W	QP05210101
▲ 3270		4822 052 10101	100R00 5% 0.33W	QP05210101
▲ 3271		4822 052 10151	150R00 5% 0.33W	QP05210151
▲ 3272		4822 052 10151	150R00 5% 0.33W	QP05210151
3273		4822 116 52234	100K 5% 0.5W	QP11652234
3274		4822 116 52234	100K 5% 0.5W	QP11652234
3275		4822 116 52297	68K 5% 0.5W	QP11652297
3276		4822 116 52297	68K 5% 0.5W	QP11652297
3277		4822 116 52176	10E 5% 0.5W	QP11652176
3278		4822 116 52176	10E 5% 0.5W	QP11652176
3279		4822 116 52291	56K 5% 0.5W	QP11652291
3280		4822 116 52291	56K 5% 0.5W	QP11652291
3281		4822 116 52296	6K8 5% 0.5W	QP11652296
▲ 3282		4822 053 10222	2K20 5% 1W	QP05310222
3283		4822 050 21009	10R00 1% 0.6W	QP05021009
3284		4822 050 21009	10R00 1% 0.6W	QP05021009
3285		4822 116 52285	470K 5% 0.5W	QP11652285
3286		4822 116 52285	470K 5% 0.5W	QP11652285
3287		4822 116 83872	220R 5% 0.5W	QP11683872
3288		4822 116 83872	220R 5% 0.5W	QP11683872
3289		4822 116 52235	1M 5% 0.5W	QP11652235
3293		4822 116 52217	270E 5% 0.5W	QP11652217
3294		4822 116 52217	270E 5% 0.5W	QP11652217
3295		4822 101 10927	TRIMMER 470R	QP10110927
3296		4822 101 10927	TRIMMER 470R	QP10110927
▲ 3297				
3300		4822 052 10101	100R00 5% 0.33W	QP05210101
3301		4822 050 11002	1K00 1% 0.4W	QP05011002
3302		4822 050 11002	1K00 1% 0.4W	QP05011002
▲ 3303		4822 053 10331	330R00 5% 1W	QP05310331
▲ 3304		4822 053 10331	330R00 5% 1W	QP05310331
▲ 3305				
▲ 3308		4822 052 10108	1R00 5% 0.33W	QP05210108
3309		4822 117 12344	2XR18 10% 2X3W.	QP11712344
3310		4822 117 12344	2XR18 10% 2X3W.	QP11712344
▲ 3311		4822 052 10221	220R00 5% 0.33W	QP05210221
▲ 3312		4822 052 10221	220R00 5% 0.33W	QP05210221
3313		4822 117 10814	10R 5% 3W	QP11710814
3314		4822 117 10814	10R 5% 3W	QP11710814
3315	PM57	4822 050 22202	2K20 1% 0.6W	QP05022202
3316		4822 116 83864	10K 5% 0.5W	QP11683864
3317		4822 116 52219	330E 5% 0.5W	QP11652219
3318		4822 116 52219	330E 5% 0.5W	QP11652219
▲ 3319		4822 052 10681	680R00 5% 0.33W	QP05210681
▲ 3320		4822 052 10681	680R00 5% 0.33W	QP05210681
3321		4822 116 52249	1K8 5% 0.5W	QP11652249
3322		4822 116 52249	1K8 5% 0.5W	QP11652249
3323		4822 116 83882	39K 5% 0.5W	QP11683882
3324		4822 116 83882	39K 5% 0.5W	QP11683882

(VERS. :VERSION, U:U.S.A., F:JAPAN, K:FAR EAST, **:EUROPE)

POS. NO	VERS. COLOR	PART NO. (FOR EUROPE)	DESCRIPTION	PART NO. (USA/JPN)	POS. NO	VERS. COLOR	PART NO. (FOR EUROPE)	DESCRIPTION	PART NO. (USA/JPN)
▲ 7256		4822 130 60117	2SC3419	QP13060117	▲ 2441		4822 121 51387	10nF 20% 16V	QP12151387
7257		4822 130 10445	2SC2240	QP13010445					
7258		4822 130 10445	2SC2240	QP13010445	▲ 2448		4822 126 13325	100nF 10% 16V	QP12613325
7259		4822 130 42949	2SA970	QP13042949	▲ 2471		4822 124 40196	220µF 20% 16V	QP12440196
7260		4822 130 42949	2SA970	QP13042949	▲ 2472				
7261		4822 130 10446	2SD2033	QP13010446	▲ 2473		4822 124 41579	10µF 20% 50V	QP12441579
7262		4822 130 10446	2SD2033	QP13010446	2525		4822 121 43526	47nF 5% 250V	QP12143526
7263		4822 130 10447	2SB1353	QP13010447	2526		4822 121 43526	47nF 5% 250V	QP12143526
7264		4822 130 10447	2SB1353	QP13010447	2527		4822 121 42469	5.6nF 5% 250V	QP12142469
7265		4822 130 10448	2SC3181N-R	QP13010448	2528		4822 121 42469	5.6nF 5% 250V	QP12142469
7266		4822 130 10448	2SC3181N-R	QP13010448	2529		4822 121 51436	820nF 10% 63V	QP12151436
7267		4822 130 10449	2SA1264N-R	QP13010449	2530		4822 121 51436	820nF 10% 63V	QP12151436
7268		4822 130 10449	2SA1264N-R	QP13010449	2531		4822 121 43396	120nF 5% 63V	QP12143396
▲ 7269	PM57	4822 130 90347	PC817	QP13090347	2532		4822 121 43396	120nF 5% 63V	QP12143396
▲ 7270	PM57	4822 130 90347	PC817	QP13090347	2533		4822 124 40248	10µF 20% 63V	QP12440248
7271		4822 130 10445	2SC2240	QP13010445	2534		4822 124 40248	10µF20% 63V	QP12440248
7272		4822 130 10445	2SC2240	QP13010445	2535		4822 121 51299	1nF 10% 50V	QP12151299
7273		4822 130 42949	2SA970	QP13042949	2536		4822 121 51299	1nF 10% 50V	QP12151299
▲ 7274		4822 209 83312	TA7317P	QP20983312	2537		4822 126 13325	100nF 10% 16V	QP12613325
▲ 7275		4822 130 44197	BC558B	QP13044197	2538		4822 126 13325	100nF 10% 16V	QP12613325
7276		4822 130 40937	BC548B	QP13040937			RESISTORS		
▲ 7277		5322 209 71759	L7815CV	QQ20971759	▲ 3345		4822 053 11331	330R00 5% 2W	QP05311331
7278		4822 209 12715	L7915CV	QP20912715	▲ 3346		4822 053 11331	330R00 5% 2W	QP05311331
▲ 7281		4822 130 44196	BC548C	QP13044196	3400		4822 116 52234	100K 5% 0.5W	QP11652234
▲ 7282		4822 130 44196	BC548C	QP13044196	3401		4822 116 83864	10K 5% 0.5W	QP11683864
					3402		4822 116 83864	10K 5% 0.5W	QP11683864
▲ 7379		4822 209 80817	L7805CV	QP20980817			4822 116 52257	22K 5% 0.5W	QP11652257
7501		4822 209 73064	NJM2068D-D	QP20973064	3403		4822 116 52283	4K7 5% 0.5W	QP11652283
7551		4822 209 13648	LC78212	QP20913648	3404		4822 116 52256	2K2 5% 0.5W	QP11652256
7552		4822 209 13648	LC78212	QP20913648	3405		4822 116 52284	47K 5% 0.5W	QP11652284
					3406		4822 116 52175	100R 5% 0.5W	QP11652175
			CONTROL BOARD		3407				
			MISCELLANEOUS		▲ 3408	PM57	4822 052 10101	100R00 5% 0.33W	QP05210101
▲ 1002	/02B/05B	4822 070 31602	FUSE T1.6A 250V IEC	QP07031602	3411	PM57	4822 116 83864	10K 5% 0.5W	QP11683864
1251	PM57	4822 276 13771	SPEAKER SYSTEM SWITCH	QP27613771	3412	PM57	4822 116 83864	10K 5% 0.5W	QP11683864
1260	PM57	4822 265 10648	HEADPHONE SOCKET	QP26510648	3413	PM57	4822 116 52257	22K 5% 0.5W	QP11652257
1260	PM47	4822 265 10653	HEADPHONE SOCKET	QP26510653	3414	PM57	4822 116 52284	47K 5% 0.5W	QP11652284
▲ 1262		4822 276 13772	POWER SWITCH	QP27613772			4822 116 52257	22K 5% 0.5W	QP11652257
1400	PM57	4822 130 10165	IR RECEIVER GP1U28XP	QP13010165	3415		4822 052 10101	100R00 5% 0.33W	QP05210101
1411					▲ 3416		4822 116 83864	10K 5% 0.5W	QP11683864
		4822 276 13114	TACT SWITCH	QP27613114	3417		4822 116 52195	47R 5% 0.5W	QP11652195
1416					3418		4822 116 52257	22K 5% 0.5W	QP11652257
1417		4822 277 11574	SOURCE SELECTION SWITCH	QP27711574	3421				
							4822 116 52283	4K7 5% 0.5W	QP11652283
1421	PM57	4822 265 10651	CINCH SOCKET - RC-5	QP26510651	3423				
1510		4822 276 13773	LOUDNESS TONE DEFEAT SW	QP27613773			4822 116 83864	10K 5% 0.5W	QP11683864
5314	PM47	4822 280 20501	RELAY 2P 24V 2A	QP28020501	3424		4822 116 83872	220R 5% 0.5W	QP11683872
5400		4822 242 72527	CERAM RESONATOR 4MHZ	QP24272527	3426	PM57	4822 116 52276	3K9 5% 0.5W	QP11652276
					3427	PM57	4822 116 83864	10K 5% 0.5W	QP11683864
			CAPACITORS		3429				
▲ 2309		4822 121 51387	10nF 20% 16V	QP12151387	3431		4822 116 83864	10K 5% 0.5W	QP11683864
▲ 2310		4822 121 51387	10nF 20% 16V	QP12151387					
2341		4822 126 13332	10nF 20% 400V	QP12613332	3438				
2400		4822 126 13325	100nF 10% 16V	QP12613325			4822 116 52257	22K 5% 0.5W	QP11652257
▲ 2401		4822 121 51387	10nF 20% 16V	QP12151387	3441				
2406		4822 124 40248	10µF 20% 63V	QP12440248	3448		4822 116 83864	10K 5% 0.5W	QP11683864
2407		4822 124 40248	10µF 20% 63V	QP12440248	3451		4822 050 11002	1K00 1% 0.4W	QP05011002
2408	PM57	4822 124 22263	220µF 20% 25V	QP12422263	3452				
2409	PM57	4822 124 80141	10nF 10% 50V	QP12480141			4822 116 83864	10K 5% 0.5W	QP11683864
2416	PM57	4822 124 22263	220µF 20% 25V	QP12422263	3453		4822 116 52222	390E 5% 0.5W	QP11652222
					3454		4822 116 52222	390E 5% 0.5W	QP11652222
2427	PM57	4822 124 80141	10nF 10% 50V	QP12480141	3455				
▲ 2430					3456		4822 116 52257	22K 5% 0.5W	QP11652257
		4822 121 51387	10nF 20% 16V	QP12151387					
▲ 2435					3458				
2440	PM57	4822 126 13325	100nF 10% 16V	QP12613325					

(VERS.:VERSION, U:U.S.A., F:JAPAN, K:FAR EAST, **:EUROPE)

POS. NO	VERS. COLOR	PART NO. (FOR EUROPE)	DESCRIPTION	PART NO. (USA/JPN)
3461 3464		4822 116 52285	470K 5% 0.5W	QP11652285
3465		4822 116 83864	10K 5% 0.5W	QP11683864
▲ 3471		4822 052 10101	100R00 5% 0.33W	QP05210101
3472		4822 116 52285	470K 5% 0.5W	QP11652285
3473		4822 116 52257	22K 5% 0.5W	QP11652257
3474	PM57	4822 116 52285	470K 5% 0.5W	QP11652285
3475		4822 116 52285	470K 5% 0.5W	QP11652285
3476		4822 116 52285	470K 5% 0.5W	QP11652285
3477 3479		4822 116 52257	22K 5% 0.5W	QP11652257
3481	PM57	4822 116 52222	390E 5% 0.5W	QP11652222
3521		4822 116 52175	100E 5% 0.5W	QP11652175
3522		4822 116 52175	100E 5% 0.5W	QP11652175
3523		4822 116 52231	820E 5% 0.5W	QP11652231
3524		4822 116 52231	820E 5% 0.5W	QP11652231
3525		4822 116 52199	68E 5% 0.5W	QP11652199
3526		4822 116 52199	68E 5% 0.5W	QP11652199
3527		4822 116 52231	820E 5% 0.5W	QP11652231
3528		4822 116 52231	820E 5% 0.5W	QP11652231
3529		4822 116 83864	10K 5% 0.5W	QP11683864
3530		4822 116 83864	10K 5% 0.5W	QP11683864
3531		4822 116 52289	5K6 5% 0.5W	QP11652289
3532		4822 116 52289	5K6 5% 0.5W	QP11652289
3533		4822 101 11478	ROTARY POTM 50K X 2	QP10111478
3534		4822 101 11478	ROTARY POTM 50K X 2	QP10111478
3535		4822 116 52244	15K 5% 0.5W	QP11652244
3536		4822 116 52244	15K 5% 0.5W	QP11652244
3537		4822 116 52284	47K 5% 0.5W	QP11652284
3538		4822 116 52284	47K 5% 0.5W	QP11652284
3539		4822 116 52289	5K6 5% 0.5W	QP11652289
3540		4822 116 52289	5K6 5% 0.5W	QP11652289
3541		4822 101 11479	ROTARY POTM 100K X 2	QP10111479
SEMICONDUCTORS				
▲ 6268	PM47	4822 130 30621	1N4148 (COL)	QP13030621
▲ 6400		4822 130 30621	1N4148 (COL)	QP13030621
▲ 6401		4822 130 30621	1N4148 (COL)	QP13030621
▲ 6402	PM57	4822 130 30621	1N4148 (COL)	QP13030621
6403 6407		4822 130 82978	LTL-16KPE	QP13082978
6408	PM57	4822 130 82978	LTL-16KPE	QP13082978
6409		4822 130 82978	LTL-16KPE	QP13082978
6410		4822 130 82978	LTL-16KPE	QP13082978
▲ 6411		4822 130 30621	1N4148 (COL)	QP13030621
▲ 6412		4822 130 30621	1N4148 (COL)	QP13030621
6413	PM57	4822 130 34174	BZX79-C4V7	QP13034174
7400		4822 209 90571	TMP47C200BN-H347	QP20990571
7401 7403		4822 130 40937	BC548B	QP13040937
▲ 7404	PM57	4822 130 44197	BC558B	QP13044197
7405	PM57	4822 130 40937	BC548B	QP13040937
▲ 7406 ▲ 7409		4822 130 44197	BC558B	QP13044197
7410		4822 130 40937	BC548B	QP13040937
▲ 7411		4822 130 44197	BC558B	QP13044197
7412	PM57	4822 209 30193	LB1641	QP20930193

NOTE ON SAFETY :

Symbol ▲ Fire or electrical shock hazard. Only original parts should be used to replaced any part marked with symbol ▲. Any other component substitution (other than original type), may increase risk of fire or electrical shock hazard.