

**SERVICE
MANUAL**

**PM-500
PM-700**

marantz

model PM500/PM700

Stereo Console Amplifier

MARANTZ DESIGN AND SERVICE

Using superior design and selected high grade components, MARANTZ Company has created the ultimate in stereo sound. Only original MARANTZ parts can insure that your MARANTZ product will continue to perform to the specifications for which it is famous.

Parts for your MARANTZ stereo are generally available within 72 hours throughout the nation via a toll-free line to our National Parts Depot in California. The sales professionals who take your call immediately refer to their own desk top computer terminal and can quickly determine the availability and price information you require. If for some reason, your order should exceed our available stock, we usually can instantly provide an alternate replacement part or current delivery information. When the order is placed and confirmed, the computer simultaneously generates "hard copy" orders at the distribution center. As hard copies come directly from the computer to the national parts depot, your requested stock is assembled and prepared for shipment and placed on the first available carrier for delivery to you.

ORDERING PARTS

Phone orders will eliminate mail delays, and we encourage the use of this method. If you order by mail, use MARANTZ parts order forms which are available from our National Parts Depot located at the following address:

SUPERSCOPE NATIONAL PARTS DEPARTMENT
20525 Nordhoff Street
Chatsworth, California 91311
Phone: 1-800-423-5108
1-213-998-9333

The following information must be supplied to eliminate delays in processing your order:

1. Complete address.
2. Complete part numbers.
3. Complete description of parts.
4. Model number for which part is required (indicate MARANTZ).
5. Account number (for account customers only).

Direct consumers will be provided with the current retail price quotation on available parts in order to advise them of the cost of the parts and shipping.

OVERSEAS PARTS ORDERING

Parts may also be ordered from the following overseas addresses:

CANADA

Superscope Canada, Ltd.
3710 Nashua Drive
Mississauga
Ontario, Canada L4V1M5

AUSTRALIA

Superscope (Australasia) Pty., Ltd.
32 Cross Street (P.O. Box 604)
Brookvale 2100 N.S.W.
Australia

JAPAN

Marantz Japan, Inc.
3622 Kamitsuruma
Sagamihara Shi
Kanagawa, Japan

EUROPE

Superscope Europe, S.A.
Avenue Leopold III, 2
7120 Perennes-Lez-Binche
Belgium

Marantz France
Rue Louis Armand 9
92600 Asnieres
Hauts-de-Seine
France

Marantz Audio U.K. Ltd.
London Road, 203
Staines
Middlesex
England

Superscope GmbH
Max-Planck-Strasse 22
D-6072 Dreieich 1
West Germany

All of the above locations are fully equipped to take care of your total service needs. Because various countries have differing configuration requirements, it is necessary that you contact the service facility in your particular country. In the event that there is no service location listed for your country, please contact the nearest facility for the necessary assistance.

marantz.
We sound better.

TABLE OF CONTENTS

SECTION	PAGE
1. INTRODUCTION	1
2. PRE-AMPLIFIER	1
3. TROUBLESHOOTING ANALYSIS	1
4. POWER AMPLIFIER ADJUSTMENT	1
5. POWER METER ADJUSTMENT	1
6. TEST EQUIPMENT REQUIRED FOR SERVICING	2
7. PERFORMANCE VERIFICATION	2
8. VOLTAGE CONVERSION	5
9. DIAGRAM AND COMPONENT LOCATIONS	6
9.1 Main Amp. Assembly (P700) Schematic Diagram and Component Locations	6
9.2 Volume and Balance Assembly (PG00) Schematic Diagram and Component Locations	6
9.3 LED Power Lamp Assembly (PY00) Schematic Diagram and Component Locations	7
9.4 Loudness Assembly (PG01) Schematic Diagram and Component Locations	7
9.5 LED Power Meter Assembly (PX00) Schematic Diagram and Component Locations	8
9.6 Head Phone Assembly (PS00) Schematic Diagram and Component Locations	8
9.7 Filter Assembly (PH00) Schematic Diagram and Component Locations (PM500 and PM700)	8
9.8 Tape and In Tape Out Assembly (PJ00) Schematic Diagram and Component Locations	9
9.9 Graphic Amp. Assembly (PF00) Schematic Diagram and Component Locations	9
9.10 Graphic Volume Assembly (PF01) Schematic Diagram and Component Locations (PM500 and PM700)	10
9.11 Phono Amp. Assembly (P400) Schematic Diagram and Component Locations (PM500 and PM700)	11
10. BLOCK DIAGRAM (PM500 and PM700)	14
11. EXPLODED VIEW AND PARTS LIST	15
12. ELECTRICAL PARTS LIST	22
13. TECHNICAL SPECIFICATIONS (PM500 and PM700)	29
14. SCHEMATIC DIAGRAM (PM500 and PM700)	32. 33

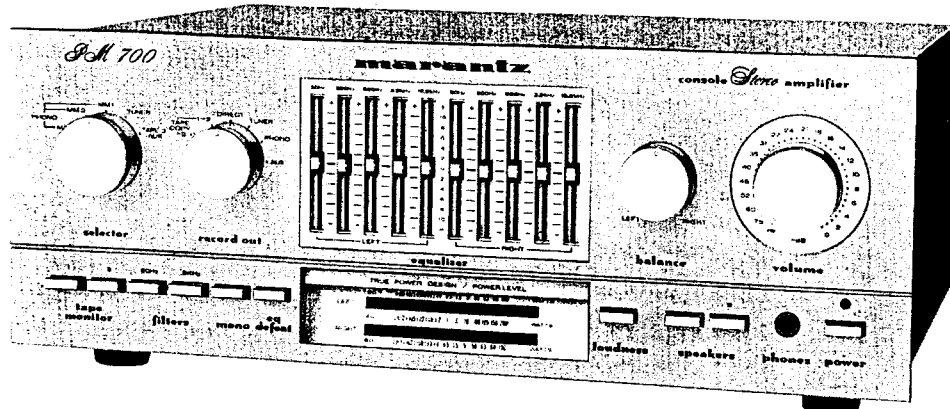

1. INTRODUCTION

This service manual was prepared for use by Authorized Warranty Stations and contains service information for the Marantz PM500/PM700 Stereo Console Amplifier. Servicing information and voltage data included in this manual are intended for use by knowledgeable and experienced personnel only. All instructions should be read carefully. No attempt should be made to proceed without a good understanding of circuitry operation.

The parts list furnishes complete ordering information. Most replacement parts should be ordered from the Marantz Company. However, a simple description is included for parts which can be obtained locally.

2. PRE-AMPLIFIER

The input signal from the PHONO-MM1 or PHONO-MM2 terminal, selected with the SELECTOR SWITCH, is applied to the PHONO AMP where it is RIAA-equalized and amplified 36 dB.

(In PM700, the signal from the PHONO-MC terminal is amplified 56 dB.)

The PHONO AMP output signal is returned to the SELECTOR switch and is also fed to the RECORDING SELECTOR (SJ04). The signals from the TUNER and AUX/TAPE 3 terminals are applied to the SELECTOR SWITCH (SJ01) and to the RECORDING SELECTOR (SJ04). (PM700 only)

The signals from the TAPE 1 IN and TAPE 2 IN are applied to the TAPE MONITOR SWITCH (SJ07) and the RECORDING SELECTOR (SJ04).

One of five signals applied to the RECORDING SELECTOR (SJ04) is selected with the RECORDING SELECTOR and fed from the TAPE 1 OUT and TAPE 2 OUT terminals.

The signal from the SELECTOR SWITCH (SJ01) is fed to the TAPE MONITOR SWITCH (SJ07), MONO SW (SH01-2) and then level controlled with the BALANCE (RG01) and VOLUME (RG02) controls.

In the volume control circuit, the signal is controlled by the loudness control in the LOUDNESS circuit when the LOUDNESS SWITCH (SG01) is ON. The signal from the VOLUME (RG02) control is amplified 19 dB with the FLAT AMP (QE01-LCH, QE02-RCH), then fed to the EQ DEFEAT SWITCH (SH01-1). The amplified signal is also fed to the ZONE CONTROL (GRAPHIC EQUALIZ-

ER) circuit. The ZONE CONTROL output signal is applied to the EQ DEFEAT SWITCH (SH01-1).

The signal selected by the EQ DEFEAT SWITCH (SH011) is supplied to the main amplifier via the FILTER SWITCH (SH01-3 for PM500, SH01-3 and SH01-4 for PM700).

3. TROUBLESHOOTING ANALYSIS

1. Excessive line consumption
 - a. Check for shorting in QN01 through to AN04.
 - b. Check for any shorted transistors Q717 through to Q728.
 - c. Check for open Q715, Q716, Q743, Q744, R737 and R738.
2. No line consumption or zero bias voltage
 - a. Check line cord and fuse. Check for a shorted Q715 and Q716.
 - b. Check for open circuits in rectifiers Q717 through to Q728 and QN01 through to QN04 or for L001.
3. High hum and noise level
 - a. Check capacitors C421, C422, C803, C804, C811, C812 and Q801 through to Q806.

4. POWER AMPLIFIER ADJUSTMENT

ADJUSTING IDLING CURRENT

Connect a DC voltmeter between the emitters of Q725 and Q727. Adjust R741 for 14 mV meter reading. Perform similar adjustment to R742, Q726 and Q728.

5. POWER METER ADJUSTMENT

PM500

Connect an 8Ω load to the left speaker terminals. Connect VTVM across the 8Ω load and an 1kHz oscillator to the left AUX/TAPE 3. Adjust the oscillator level for a 20V VTVM reading. Adjust RX39 (L-CH) so that the power meter indicates 50W. Perform the same adjustment for the right channel (RX40).

PM700

Connect an 8Ω load to the left speaker terminals. Connect VTVM across the 8Ω load and an 1kHz oscillator to the

left AUX/TAPE 3. Adjust the oscillator level for a 23.6V VTVM reading. Adjust RX39 (L-CH) so that the power meter indicates 70W. Carry out the same adjustment for the right channel (RX40).

6. TEST EQUIPMENT REQUIRED FOR SERVICING

Table 1 lists the test equipment required for servicing the PM500/PM700 Stereo Console Amplifier. The wattmeter, AC voltmeter, and variable autotransformer may be assembled as a test fixture as shown schematically in Figure 1. The load resistors and AC ammeter may be assembled into a second test fixture as shown in Figure 2.

7. PERFORMANCE VERIFICATION

TEST PROCEDURE

A. TEST EQUIPMENT

Refer to Table 1 for required test equipment.

B. PRELIMINARY PROCEDURES

1. Make the test setup shown in Figure 1 with the instrument controls set in the following positions:

Line Switch	OFF
Variable-line switch	Variable
Wattmeter Switch	ON
Variable Autotransformer	0 V (fully CCW)
Load	8 ohms (0.5 mfd—OFF)
Audio Generator	1 kHz
Output	5 V range
Gain	Minimum
AC Voltmeter	30 V range

2. Make sure that connections between the resistive load and the system terminals of the PM500/PM700 have negligible resistance when compared with the resistance of the load itself. Appreciable resistance in wiring adds to the total load, resulting in inaccurate measurements of output power.
3. Connect amplifier output to load and connect AC cord to line power. Connect shorting plugs to the Phono input jacks of the PM500/PM700.

Table 1. Test Equipment Required for Servicing

Item	Manufacturer and Model No.	Use
Distortion Analyzer Audio Oscillator AC Voltmeter	Sound Technology Model 1700B	Distortion Measurements Sinewave and squarewave signal source voltage measurements (AC)
Oscilloscope	Tektronix Model T932 Philips Model 3232	Waveform analysis and trouble shooting and ASO alignment
Circuit Tester		Trouble shooting
DC Voltmeter	Fluke Model 8000 "Digital" Simpson Model 313, Triplet Model 801	Voltage measurements (DC)
AC Wattmeter	Simpson Model 1379	Monitors primary power to amplifier
AC Ammeter	Commercial Grade (1 ~ 10 A)	Monitors amplifier output under short circuit condition
Line Voltmeter	Simpson Model 1359	Monitors potential of primary power to amplifier
Variable Autotransformer	Superior Electronic Co., Powerstet Model 116B-10A	Adjusts level of primary power to amplifier
Shorting Plug	Use phono plug with 600 ohm across center pin and shell	Shorts amplifier input to eliminate noise pickup
Output Load (8 ohms, $\pm 0.5\%$ 100 W)	Commercial Grade	Provides 8-ohm load for amplifier output termination
Output Load (4 ohms, $\pm 0.5\%$ 100 W)	Commercial Grade	Provides 4-ohm load for amplifier output termination
Output Load Capacitor (0.5 mfd)	Mylar	Provides capacitive load for instability checks
AC Power Control Box	Optional Item. Fabricate in accordance with Figure 1	Monitors and controls primary power for amplifier
Amplifier Output Load Box	Optional Item. Fabricate in accordance with Figure 2	Provides various amplifier loads and can monitor shorted output

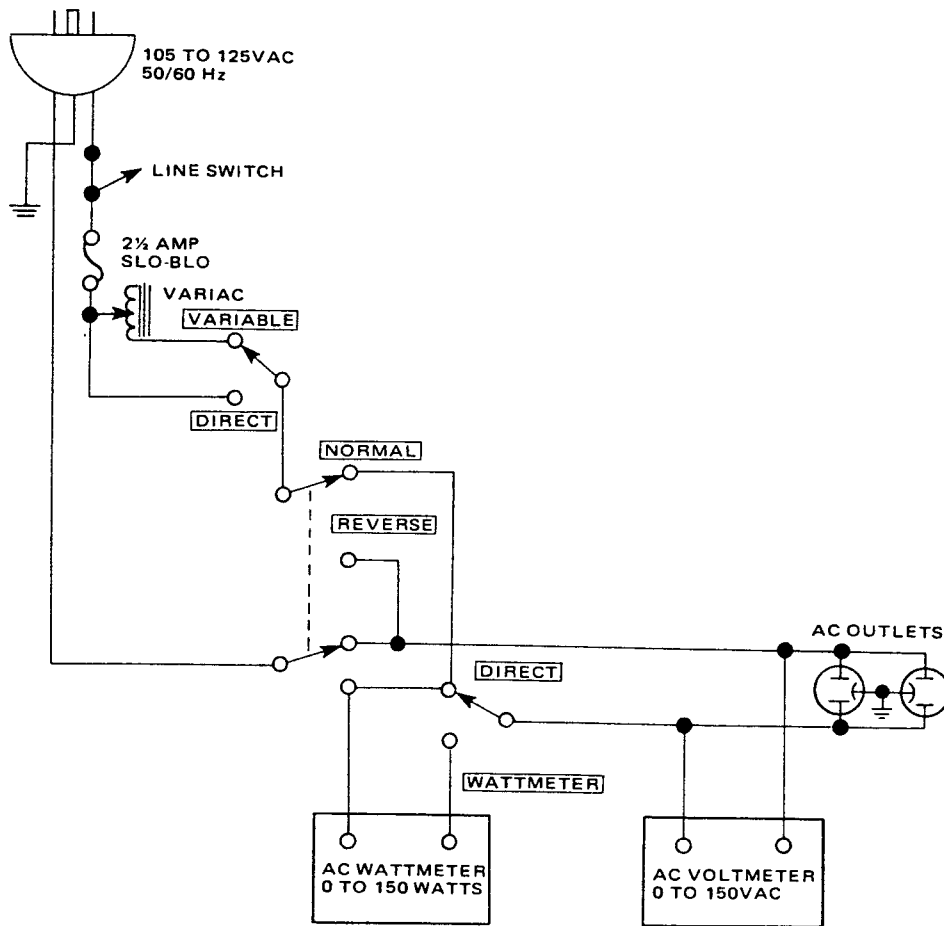

Figure 1. AC Power Control Box Simplified Schematic

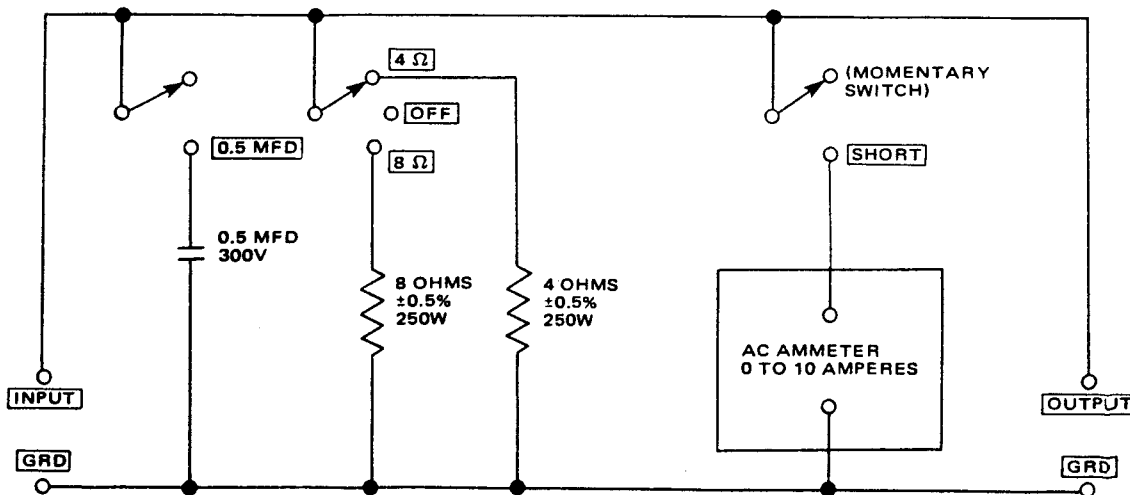

Figure 2. Amplifier Output Load Box Simplified Schematic

C. TOTAL HUM AND NOISE TEST

1. With shorting plugs connected to the Phono input jacks and an 8 ohm resistive load connected across the speaker system output terminals, connect a distortion analyzer across the load.

NOTE:

If the distortion analyzer does not contain a built-in voltmeter, an AC VTVM may be substituted.

2. Set the distortion analyzer controls for voltage measurements and apply power to the amplifier. Set the volume control fully CCW. Set the SELECTOR switch to PHONO.
3. If the distortion analyzer indicates more than 1.0 mV refer to the trouble analysis section of this manual.
4. Set the volume control fully CW. If the distortion analyzer indicates more than 15 mV, refer to the trouble analysis section of this manual.

D. MAXIMUM POWER OUTPUT

1. Connect the audio oscillator to the AUX input. Set audio oscillator frequency to 1 kHz. Set SELECTOR switch to AUX.
2. With the distortion analyzer connected across the output load (8-ohm), set the analyzer on the 30 VAC scale.
3. Turn the analyzer on and increase the audio oscillator output to 150 mV. The AC VTVM should read 23.6 VAC (20 VAC For Model PM500 only) or more.

E. HARMONIC DISTORTION TEST

1. Set the frequency of the audio oscillator and the distortion analyzer to 20 kHz.
2. Set the controls of the analyzer for voltage measurement on the 30 volt scale.
3. Adjust the audio oscillator output level until the analyzer meter indicates 23.6 VAC. (20 VAC For Model PM500 only)
4. Switch the distortion analyzer to Set Level and adjust SENSITIVITY for full scale reading on 0 ~ 0.1% scale.
5. Measure the total harmonic distortion with the analyzer and verify it is less than 0.03%.

NOTE:

Any parasitic oscillation in the amplifier will be displayed on the oscilloscope when capacitance is switched into the load.

6. Switch the distortion analyzer back to SET LEVEL. (Do not readjust sensitivity of analyzer.)
7. Change the frequency of the audio oscillator and distortion analyzer to 1 kHz. Adjust audio oscillator output for a full scale reading on the 0 ~ 1% scale.
8. Measure the distortion, verifying it is no greater than 0.03%.
9. Repeat steps 7 and 8, changing frequency to 20 Hz. Distortion should be no more than 0.03%.
10. Check for parasitic oscillation; there should be none.

CAUTION (For Model PM700 only)

PM700 Heat-loop type Cooling System

The Model PM700 uses a heat pipe loop to cool power transistors. At the bottom of the pipe loop, the Freon enclosed in evaporatively cools the power transistors, then moves through the pipe to be cooled and liquefied by cooling fins.

The Freon liquid drops back to the bottom of the pipe loop, to continue the cooling cycle.

The heat loop is designed to give best performance when

the PM700 is properly set. However, in a case of repair or measurement, approximately the same performance can be obtained if the PM700 is set up as shown in the following figures. If the inclination of the case exceeds the maximum value shown below, the liquefied Freon cannot return to the bottom of the pipe loop and the convection cycle ceases, so that transistors are not cooled, resulting in problems from overheating.

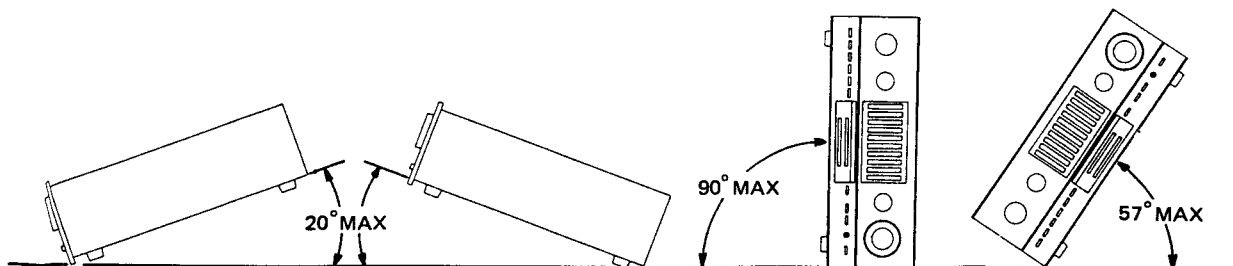

8. VOLTAGE CONVERSION

To convert the unit to a different power source voltage, change the position as illustrated in the drawing below.

CAUTION: DISCONNECT POWER SUPPLY CORD FROM AC OUTLET BEFORE CONVERTING VOLTAGE. PLEASE DO NOT DISASSEMBLE THE VOLTAGE SELECTOR ABSOLUTELY.

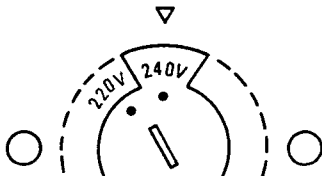
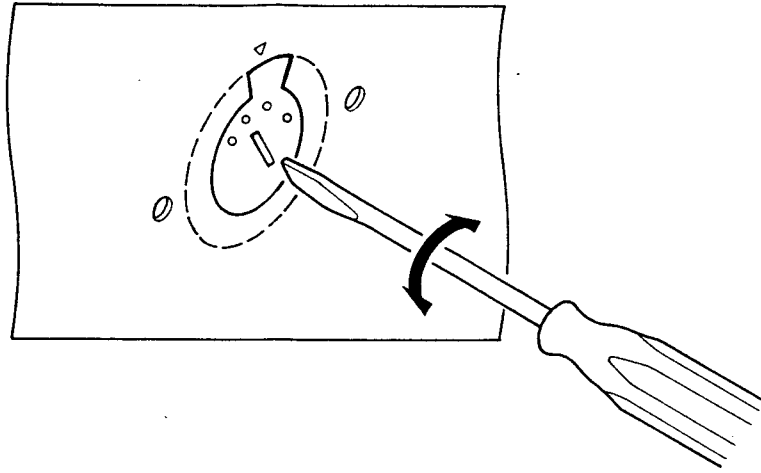

(T) (A) Versions

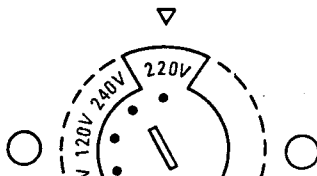

(N) Version

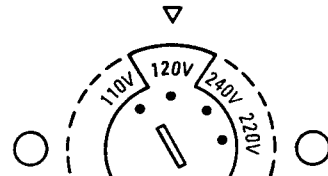

(P) Version

Note on safety: The parts marked with \triangle are important parts on the safety. Please use the parts having the designated parts number without fail.

9. DIAGRAM AND COMPONENT LOCATIONS

9.1 Main Amp. Assembly (P700) Schematic Diagram and Component Locations

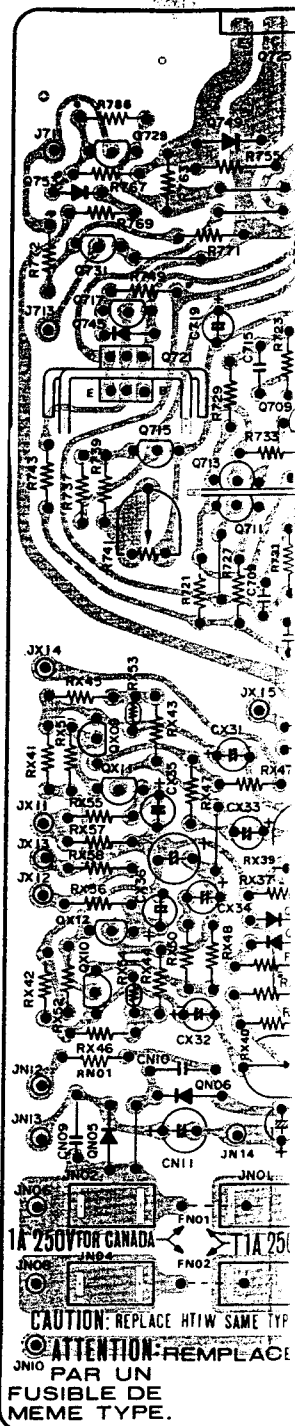
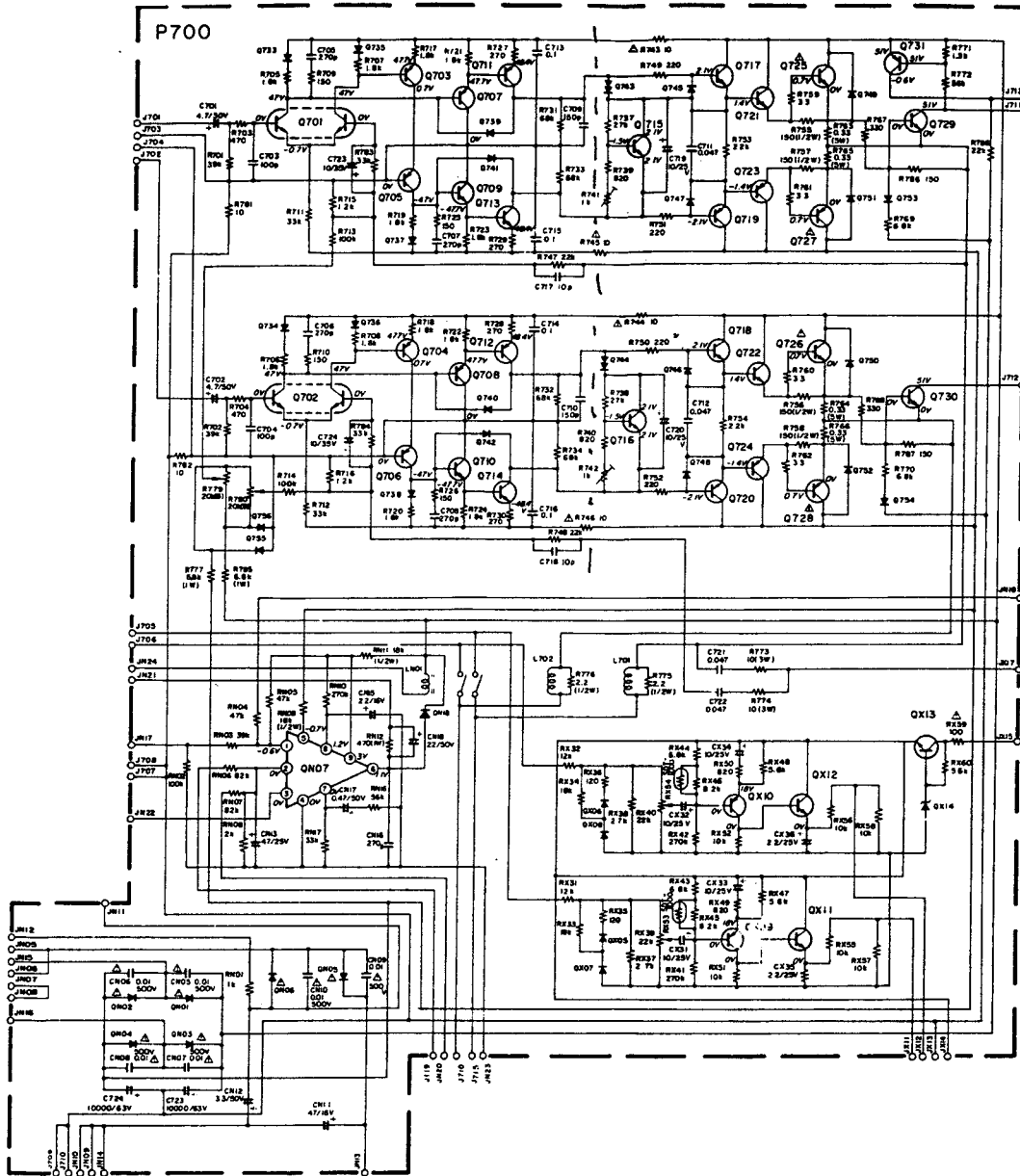

9.2 Volume and Balance Assembly (PG00) Schematic Diagram and Component Locations

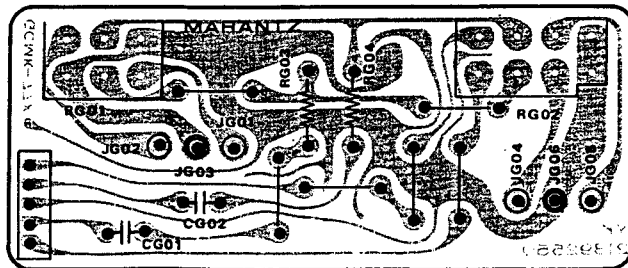
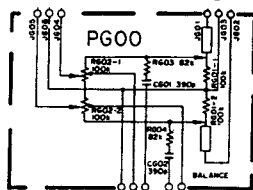

9.5 LED Power Meter Assembly (PX00)
Schematic Diagram and Component Locations

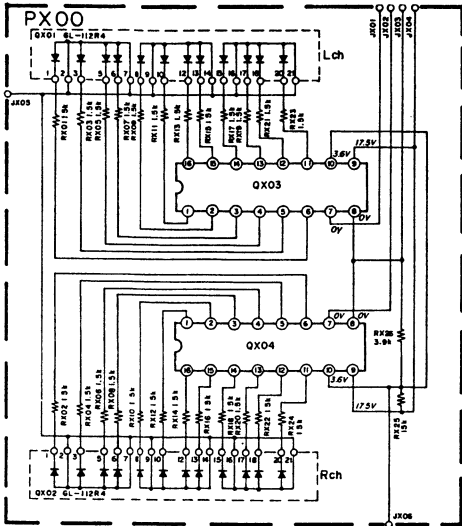

9.6 Head Phone Assembly (PS00)
Schematic Diagram and Component Locations

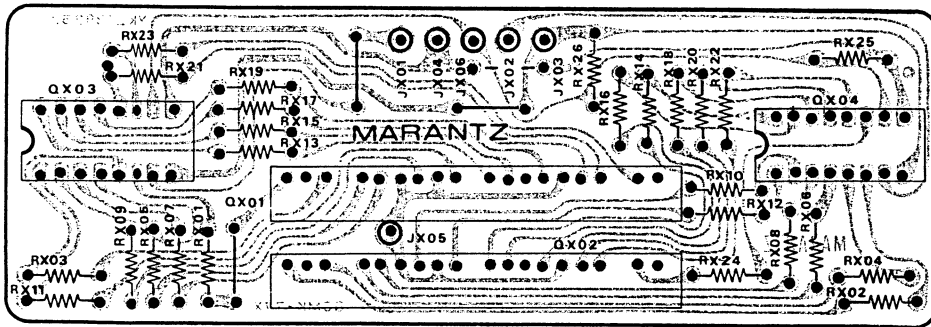
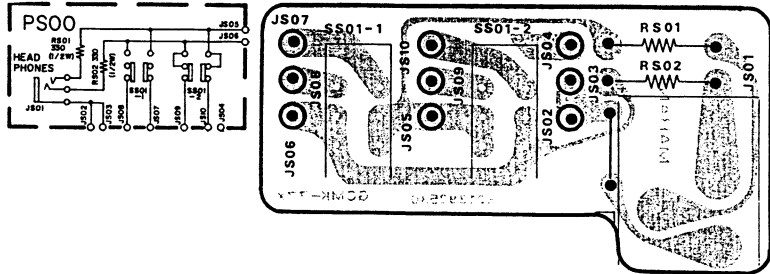

9.7 Filter Assembly (PH00) Schematic Diagram and Component Locations (PM500 and PM700)

(PM500 ONLY)

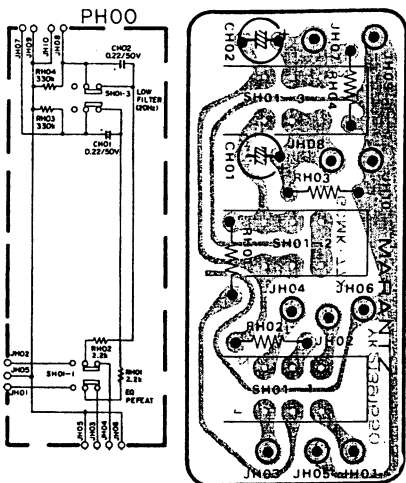

(PM700 ONLY)

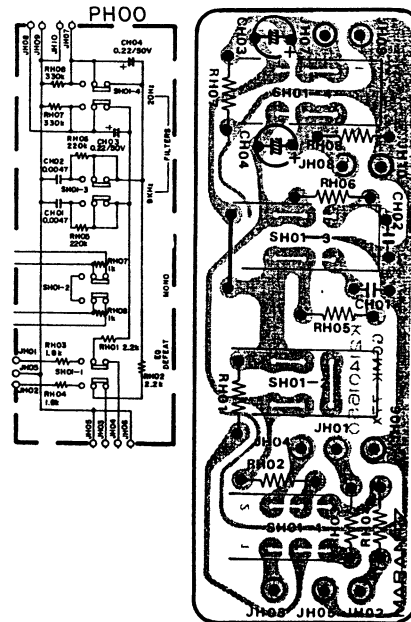

9.10 Graphic Volume Assembly (PF01) Schematic Diagram and Component Locations (PM500 and PM700)

(PM500 ONLY)

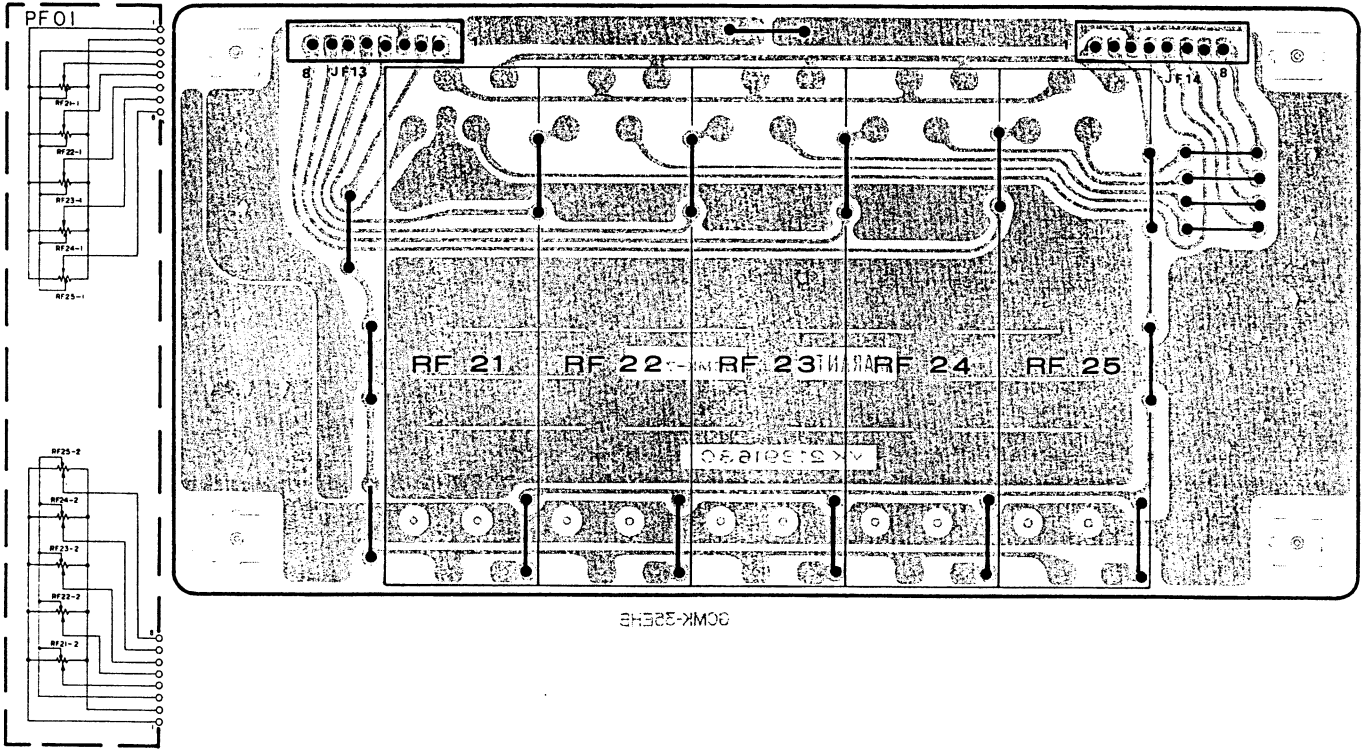

(PM700 ONLY)

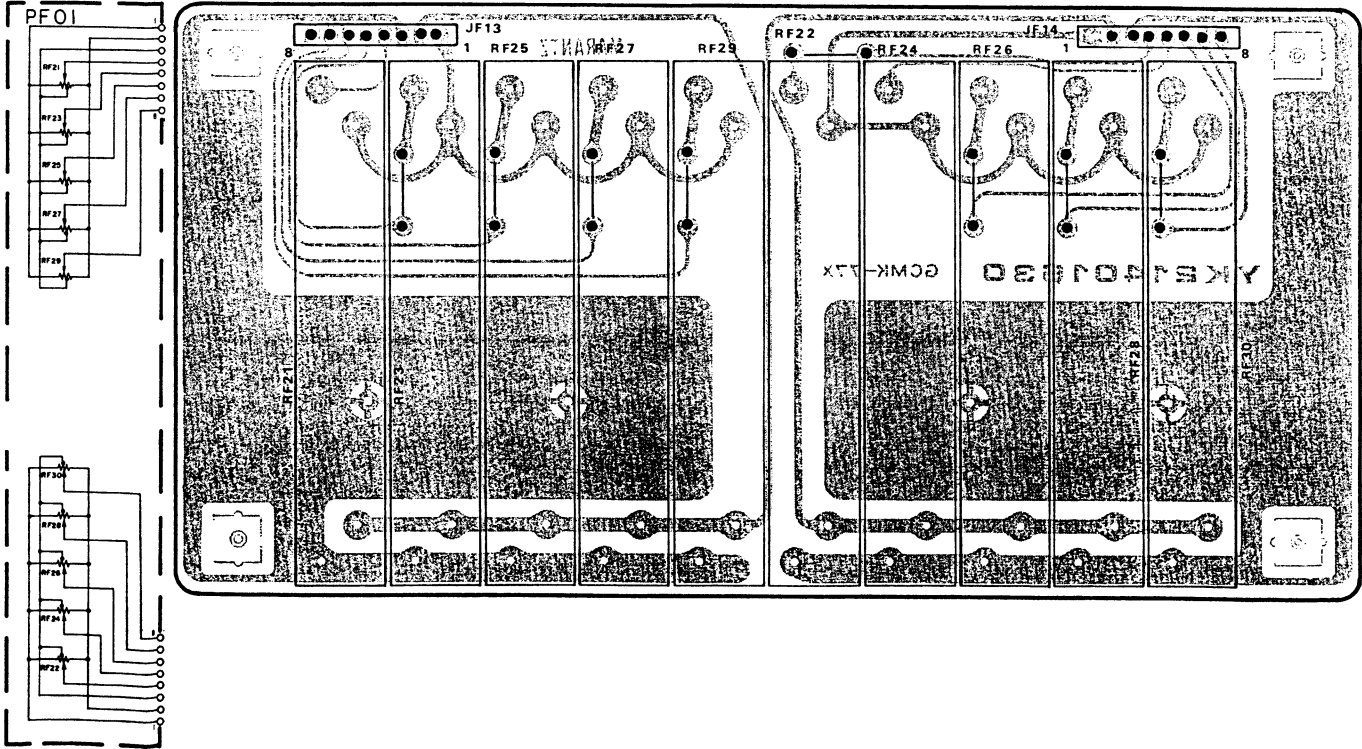

9.11 Phono Amp. Assembly (P400) Schematic Diagram and Component Locations (PM500 and PM700)

(PM500 ONLY)

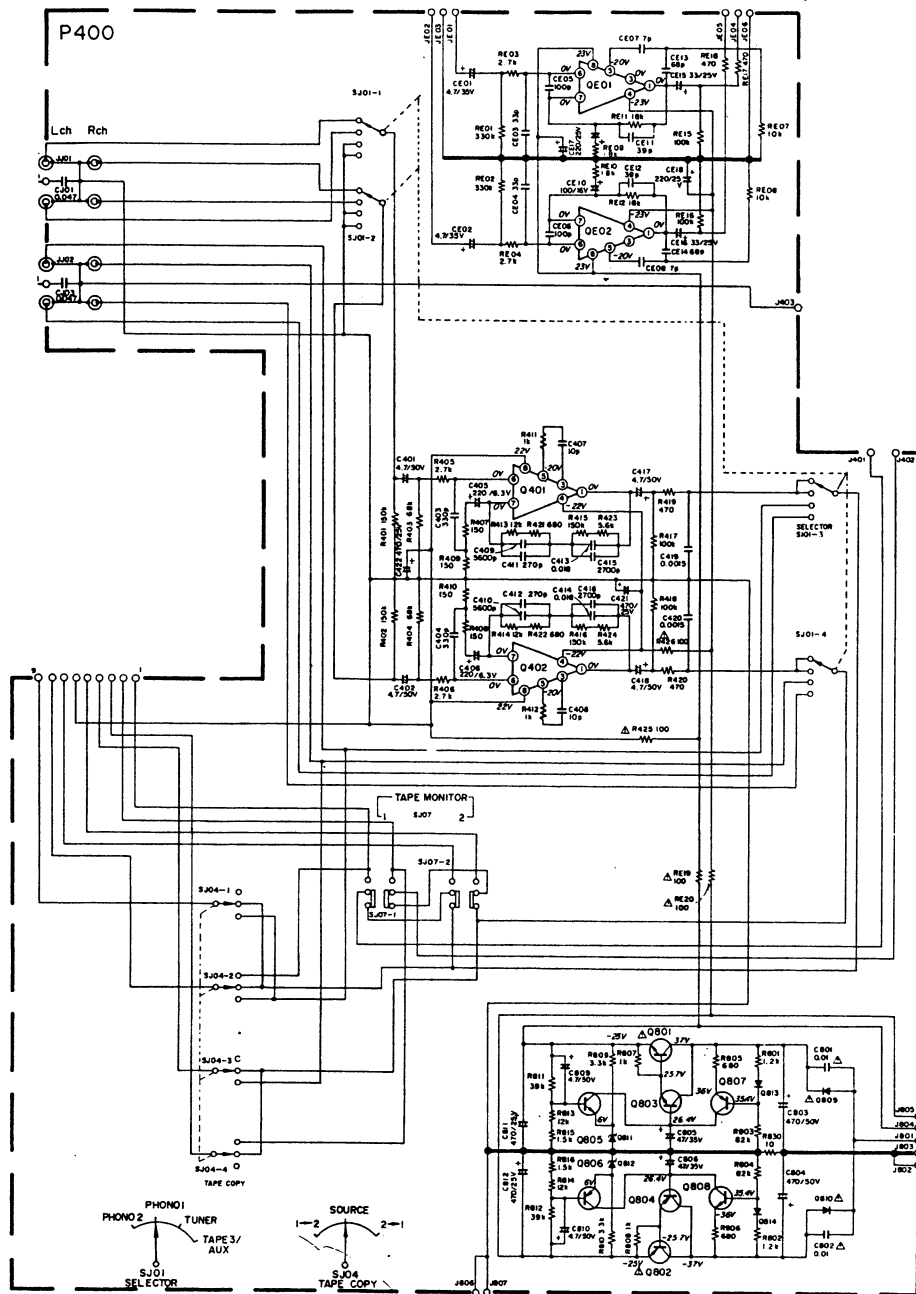

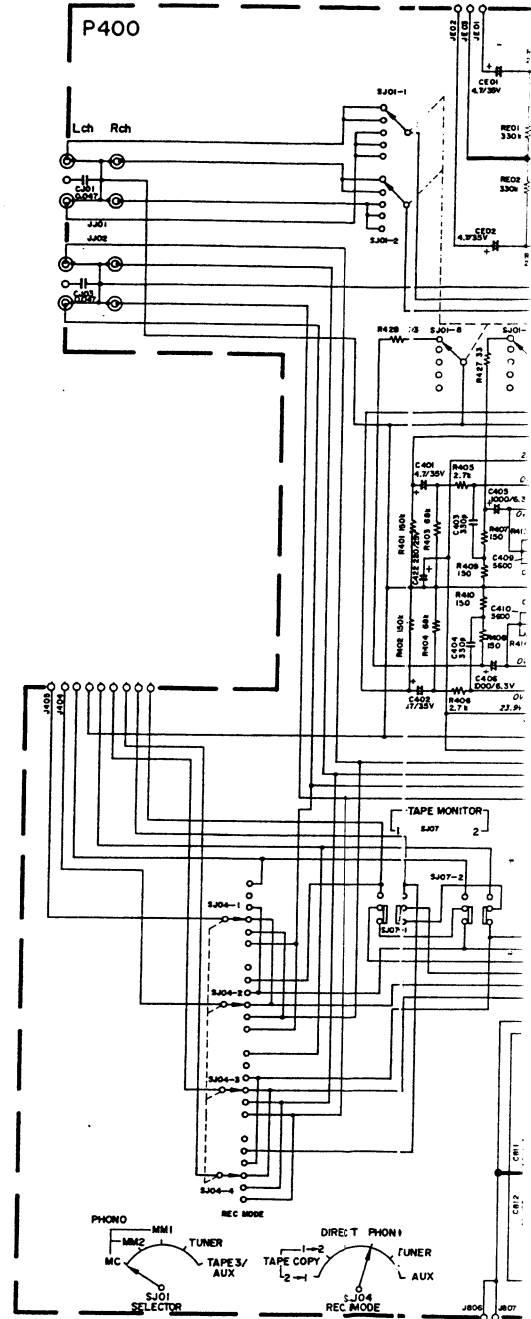
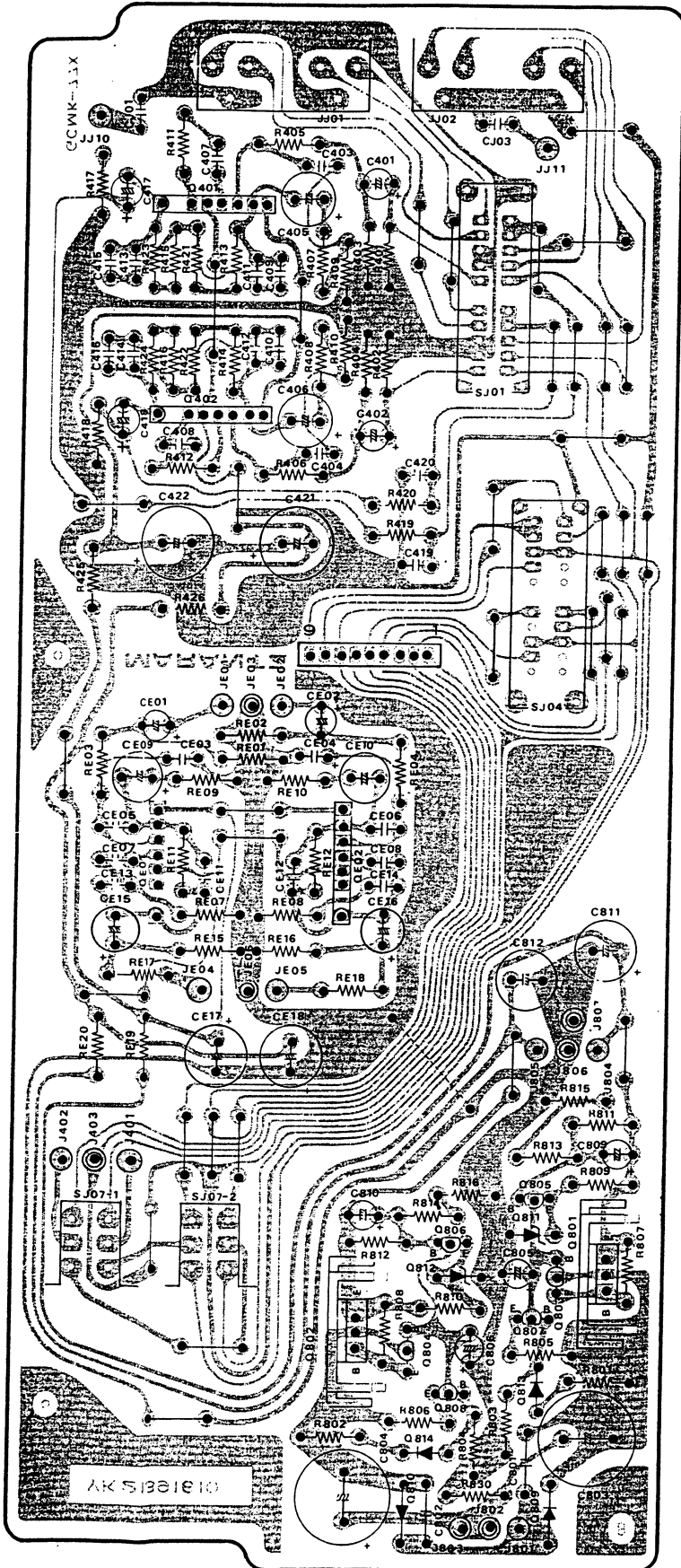

10. BLOCK DIAGRAM (PM500 and PM700)

MODEL PM500

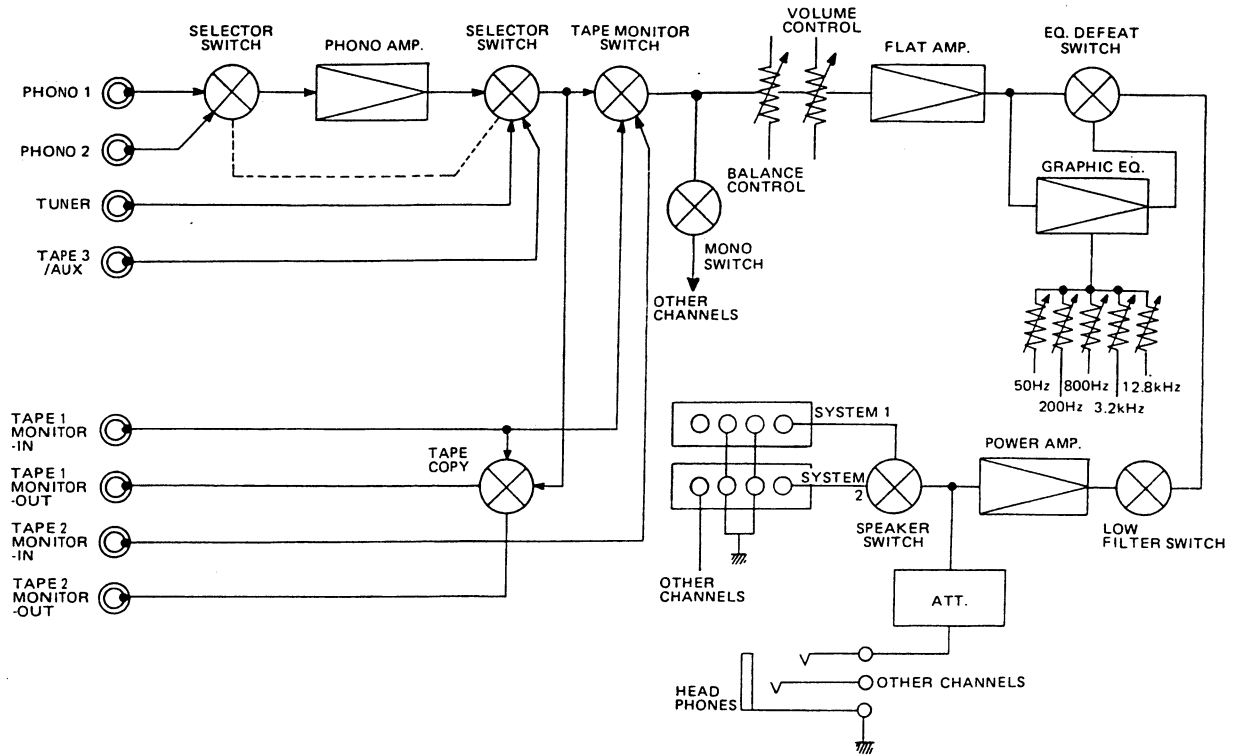

MODEL PM700

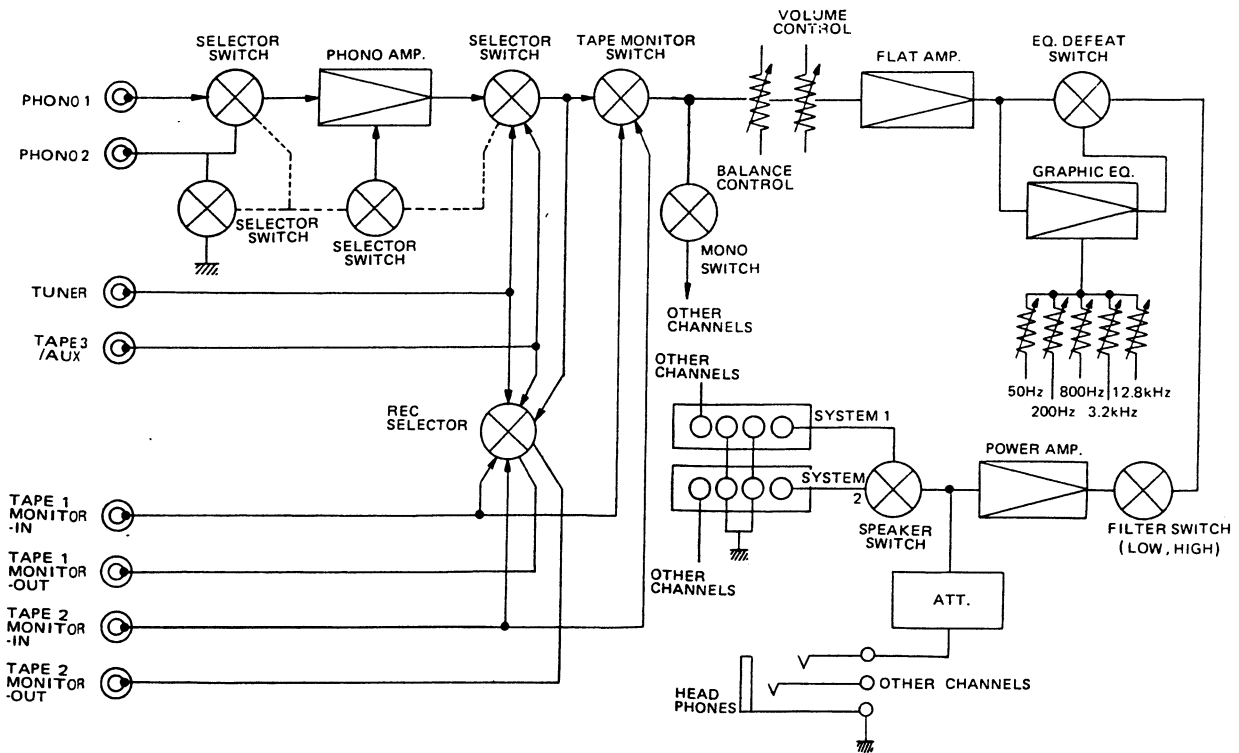

11. EXPLODED VIEW AND PARTS LIST

• [C01-99] Front Panel

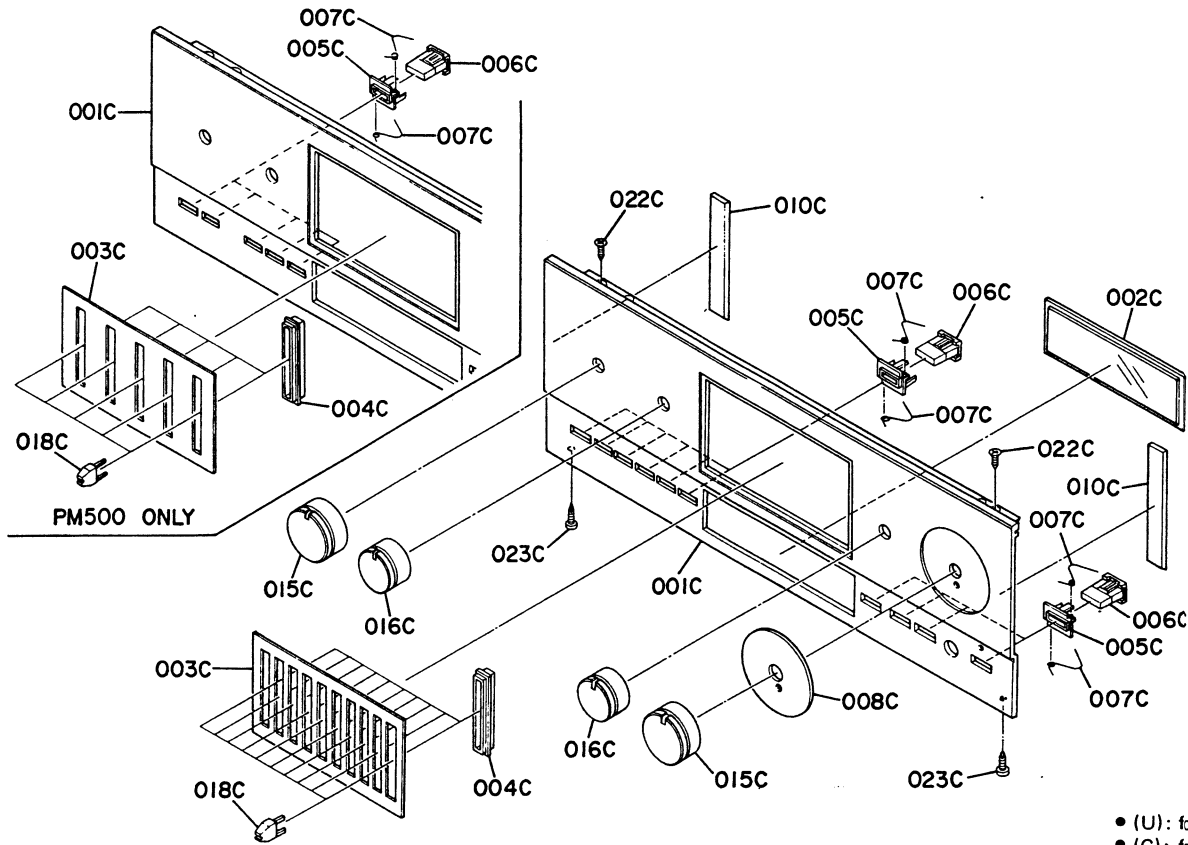

- (U): for U.S.A.
- (C): for Canada
- (N): for Europe
- (A): for Australia

REF. DESIG.	Q'TY				PART NO.	DESCRIPTION
	U	C	N	A		
						(PM500, ONLY)
A	1	1	1	1	2139063400	Front Panel Assembly
001C	1	1	1	1	2139063010	Escutcheon, Front Panel
002C	1	1	1	1	2129158020	Window, Meter
003C	1	1	1	1	2139063020	Escutcheon, Slide VR.
004C	5	5	5	5	2129259023	Bushing, Slide VR.
005C	9	9	9	9	2127259010	Bushing, Push SW.
008C	1	1	1	1	2129063030	Escutcheon, Volume
010C	2	2	2	2	2128118010	Spacer
						(PM700, ONLY)
A	1	1	1	1	2140063400	Front Panel Assembly
001C	1	1	1	1	2140063010	Escutcheon, Front Panel
002C	1	1	1	1	2140158010	Window, Meter
003C	1	1	1	1	2140063020	Escutcheon, Slide VR.
004C	10	10	10	10	2129259020	Bushing, Slide VR.
005C	10	10	10	10	2127259010	Bushing, Push SW.
008C	1	1	1	1	2129063030	Escutcheon, Volume
010C	2	2	2	2	2128118010	Spacer

REF. DESIG.	Q'TY				PART NO.	DESCRIPTION
	U	C	N	A		
006C	9	9	9	9	2127154010	Knob (PM500, Only)
006C	10	10	10	10	2127154010	Knob (PM700, Only)
007C	18	18	18	18	2127115010	Spring (PM500, Only)
007C	20	20	20	20	2127115010	Spring (PM700, Only)
015C	2	2	2	2	2129154010	Knob
016C	2	2	2	2	2129154020	Knob
018C	5	5	5	5	2129154040	Knob (PM500, Only)
018C	10	10	10	10	2129154040	Knob (PM700, Only)
022C	2	2	2	2	51340308A0	F.H. Tapped Screw F3 x 8
023C	2	2	2	2	51280308B0	B.H. Tapped Screw B3 x 8

• [C02-99] Top Cover

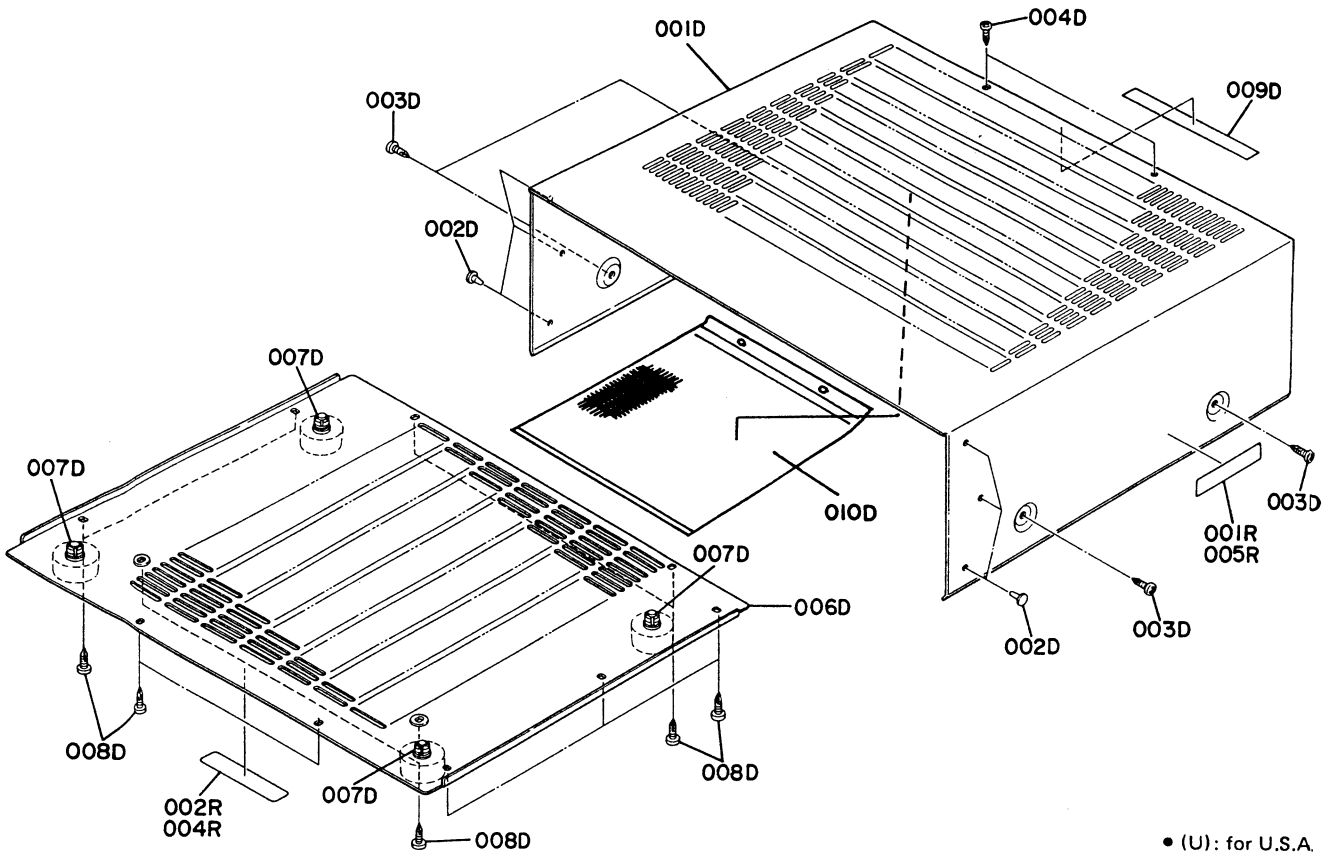

- (U): for U.S.A.
- (C): for Canada
- (N): for Europe
- (A): for Australia

REF. DESIG.	Q'TY				PART NO.	DESCRIPTION
	U	C	N	A		
001D			1		2140257010	Lid, Top Cover
002D	6	6	6	6	2991259010	Bushing
003D	4	4	4	4	51260408U0	F.Washer Screw 4 x 8
004D	2	2	2	2	51280308U0	B.H. Tapped Screw B3 x 8
006D	1	1	1	1	2140257020	Lid, Bottom Cover
007D	4	4	4	4	2259057010	Leg
008D	11	11	11	11	51280410U0	B.H. Tapped Screw B4 x 10
009D	1	1		1	2918107270	Sheet
010D			1		2140202010	Net
001D	1	1		1	2140257110	Lid, Top Cover

REF. DESIG.	Q'TY				PART NO.	DESCRIPTION
	U	C	N	A		
001R	1		1	1	2932861010	Label
002R	1		1	1	2578861010	Label
004R			1		2911861110	Label
005R			1		2911861140	Label

• [C03-99] Rear Panel

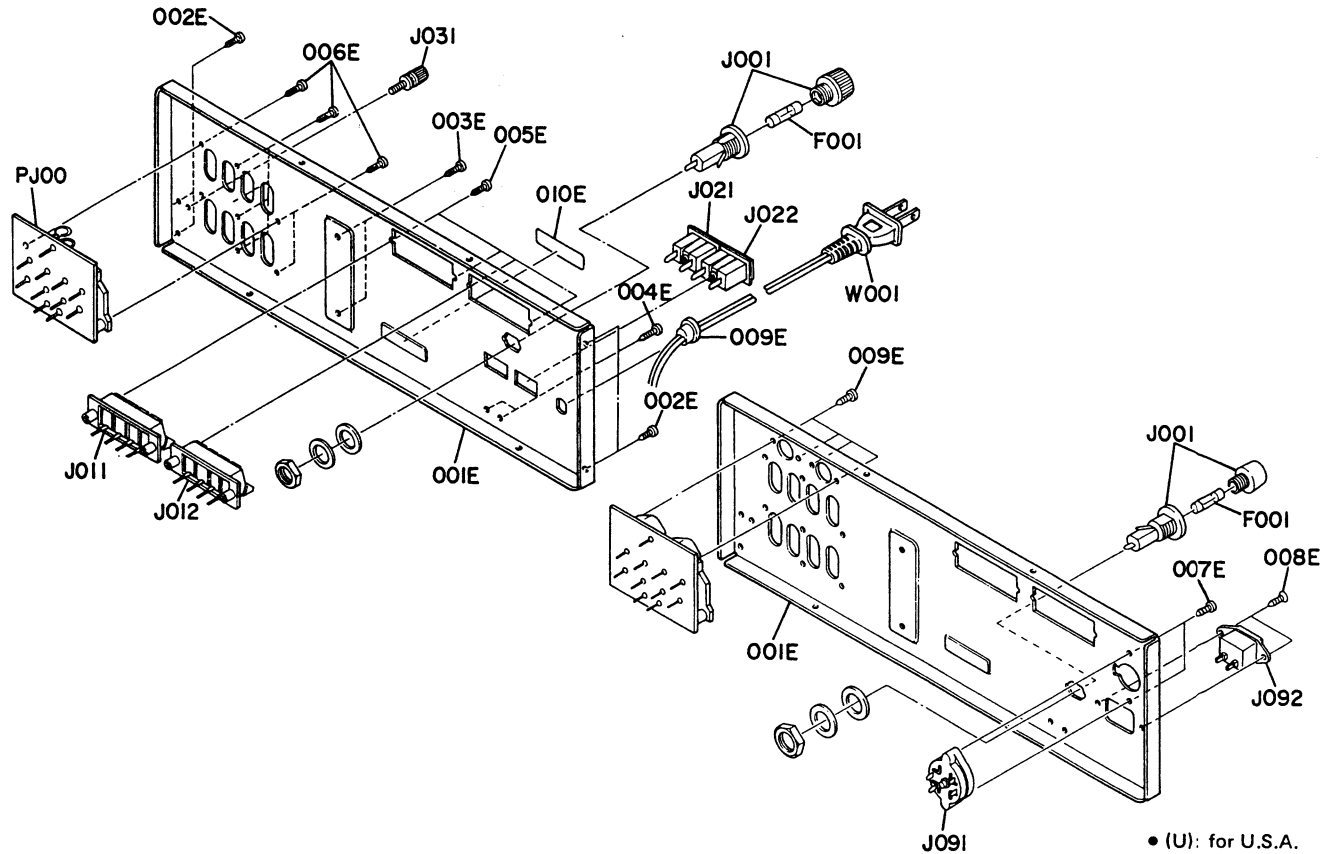

- (U): for U.S.A.
- (C): for Canada
- (N): for Europe
- (A): for Australia

REF. DESIG.	Q'TY				PART NO.	DESCRIPTION
	U	C	N	A		
001E	1				2139160210	(PM500, ONLY) Bracket, Rear Panel
001E		1			2139160270	Bracket, Rear Panel
001E			1		2139160220	Bracket, Rear Panel
001E				1	2139160240	Bracket, Rear Panel
001E	1				2140160210	(PM700, ONLY) Bracket, Rear Panel
001E		1			2140160260	Bracket, Rear Panel
001E			1		2140160220	Bracket, Rear Panel
001E				1	2140160250	Bracket, Rear Panel
002E	4	4	4	4	51280308U0	B.H. Tapped Screw B3 x 8
003E	2	2	2	2	51280308U0	B.H. Tapped Screw B3 x 8
004E	2	2	2	2	51280308U0	B.H. Tapped Screw B3 x 8
005E	4	4	4	4	51280308U0	B.H. Tapped Screw B3 x 8
006E	8	8	8	8	51280308U0	B.H. Tapped Screw B3 x 8
007E		2	2		51280310U0	B.H. Tapped Screw B3 x 10
008E		2	2		51420308T0	O.C.H. Tapped Screw O3 x 8
009E	1	1			1455259030	Bushing, AC Cord
009E		4	4		51100306S9	B.H.M. Screw B3 x 6
010E		1	1		4581861010	Label

REF. DESIG.	Q'TY				PART NO.	DESCRIPTION
	U	C	N	A		
Δ F001	1	1			FS10350010	Fuse, 3.5A (PM500, Only)
Δ F001			1	1	FS10125800	Fuse, 1.25A (PM500, Only)
Δ F001	1	1			FS10500040	Fuse, 5A (PM700, Only)
Δ F001			1	1	FS10200800	Fuse, 2A (PM700, Only)
Δ J001	1				YJ08000310	Jack, Fuse Holder
Δ J001		1			YJ08000300	Jack, Fuse Holder
Δ J001		1	1		YJ08000290	Jack, Fuse Holder
J011	1	1	1	1	YT03040170	Terminal, System 1
J012	1	1	1	1	YT03040170	Terminal, System 2
Δ J021	1	1			YJ04000560	Jack, AC Outlet
Δ J022	1	1			YJ04000560	Jack, AC Outlet
J031	1	1	1	1	YL03010240	Terminal, GND
Δ J091		1	1		BY05080010	Voltage Selector
Δ J092			1	1	YP04000590	Plug, AC Inlet
Δ W001	1	1			YC01900070	A.C. Power Cord

● [P01-99] Chassis and General Parts

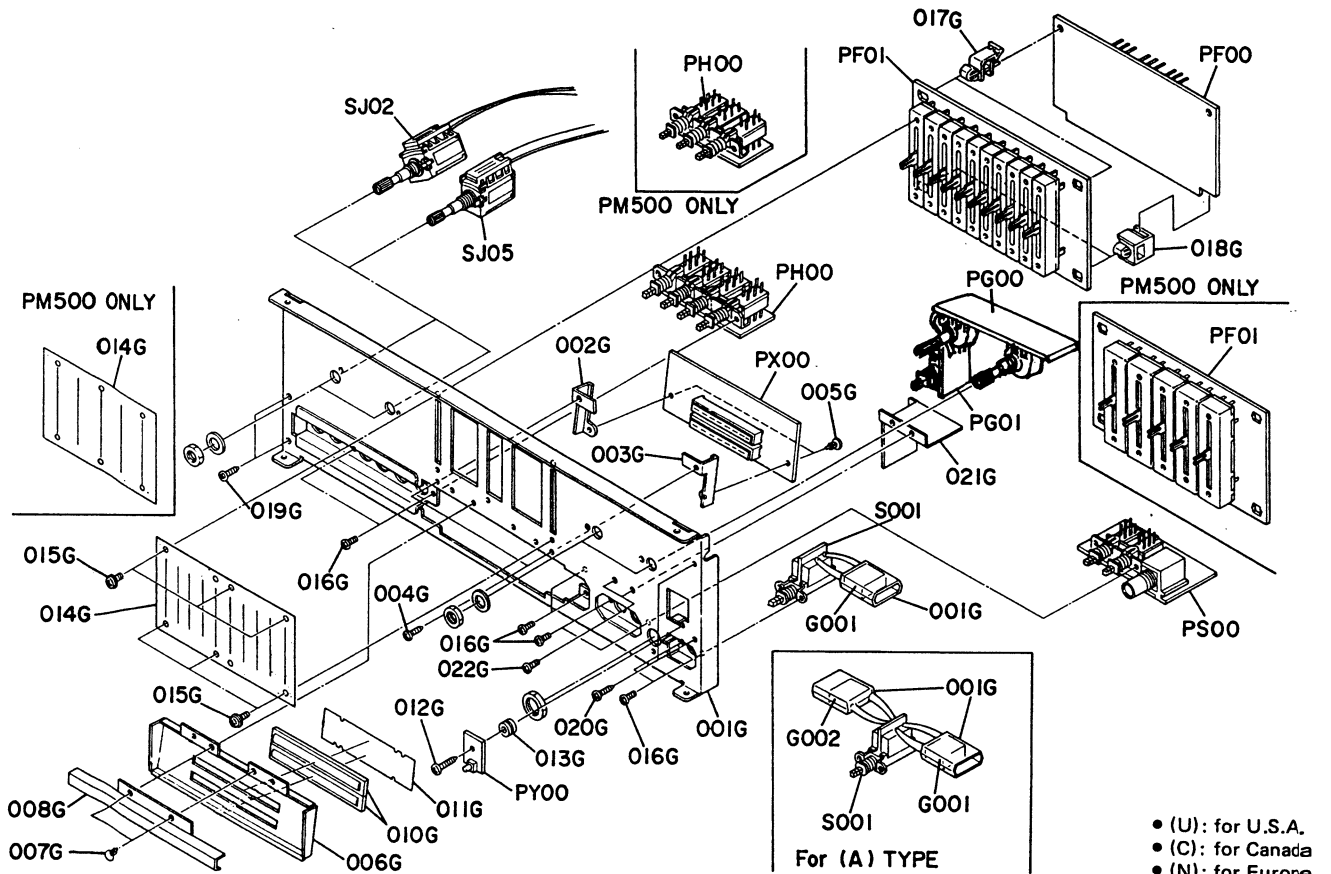

- (U): for U.S.A.
- (C): for Canada
- (N): for Europe
- (A): for Australia

REF. DESIG.	Q'TY				PART NO.	DESCRIPTION
	U	C	N	A		
001G	1	1	1	1	2140160010	Bracket, Front Chassis
002G	1	1	1	1	2140160040	Bracket
003G	1	1	1	1	2140160050	Bracket
004G	2	2	2	2	2912259020	Bushing
005G	2	2	2	2	2912259020	Bushing
006G	1	1	1	1	2139302010	Dial (PM500, Only)
006G	1	1	1	1	2140302010	Dial (PM700, Only)
007G	2	2	2	2	2276005050	Bushing
008G	1	1	1	1	2140063030	Escutcheon, Cover
010G	2	2	2	2	2127355010	Lens
011G	1	1	1	1	2129303040	Mask
012G	1	1	1	1	5128031480	B.H. Tapped Screw B3 x 14
013G	1	1	1	1	4367259020	Bushing
014G	1	1	1	1	2139303010	Mask (PM500, Only)
014G	1	1	1	1	2140303010	Mask (PM700, Only)
015G	6	6	6	6	51450306S9	F. Washer Screw F3 x 6
016G	8	8	8	8	51100306A9	B.H.M. Screw B3 x 6
017G	2	2	2	2	2139271010	Holder
018G	2	2	2	2	2139271020	Holder

REF. DESIG.	Q'TY				PART NO.	DESCRIPTION
	U	C	N	A		
019G	2	2	2	2	51280306B0	B.H. Tapped Screw B3 x 6
020G	2	2	2	2	51280306B0	B.H. Tapped Screw B3 x 6
021G	1	1	1	1	2139109010	Shield
022G	2	2	2	2	51280308B0	B.H. Tapped Screw B3 x 8
001G	1	1			2219120010	Insulator
001G			1	2	3926120010	Insulator
△ S001	1	1			SP01010280	Push Switch, Power
△ S001			1	1	SP02010440	Push Switch, Power
JS02	1	1	1	1	SR00040060	Rotary Switch
JS05	1	1	1	1	SR00030030	Rotary Switch
△ G001	1				BF10400030	Cap. Comp. Spark Killer
△ G001		1			BF33300020	Cap. Comp. (PM500, Only)
△ G001			1		BF10400050	Cap. Comp. (PM700, Only)
△ G001			1	1	DF17223800	Film Cap. 0.022μF ±20%
△ G002				1	DF17223800	Film Cap. 0.022μF ±20%

● [P02-99] Main P.W. Board and General Parts (PM500 ONLY)

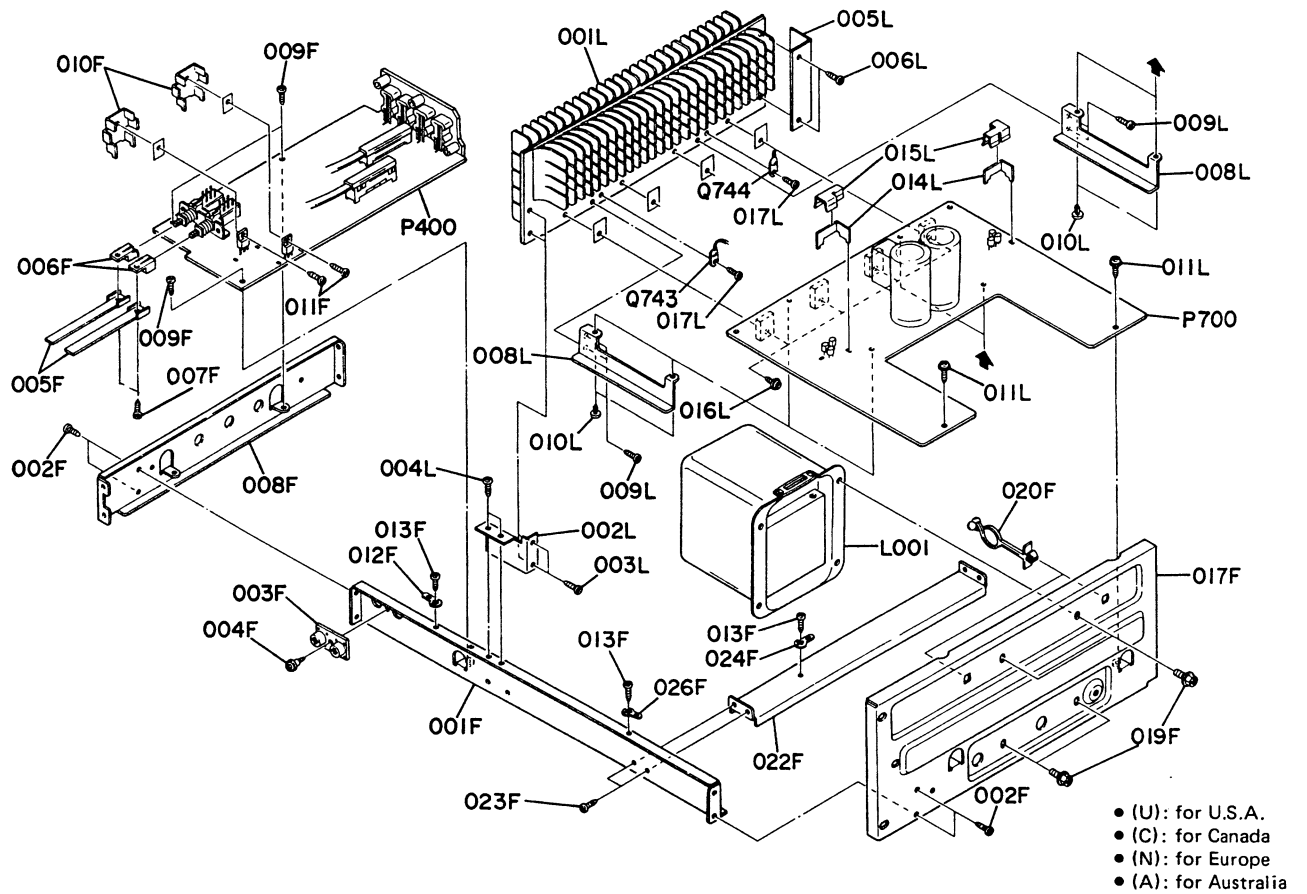

REF. DESIG.	Q'TY				PART NO.	DESCRIPTION
	U	C	N	A		
(PM500, ONLY)						
001F	1	1	1	1	2140126010	Stay, Front
002F	4	4	4	4	51280308U0	B.H. Tapped Screw B3 x 8
003F	1	1	1	1	2213106010	Sustainer
004F	1	1	1	1	4367051030	Guide
005F	2	2	2	2	2140354010	Lever
006F	2	2	2	2	2891271010	Holder
007F	2	2	2	2	51280308B0	B.H. Tapped Screw B3 x 8
008F	1	1	1	1	2140160030	Bracket (L)
009F	3	3	3	3	51260308B0	B.H. Tapped Screw B3 x 8
010F	2	2	2	2	2963267020	Heatsink
011F	2	2	2	2	51280306B0	B.H. Tapped Screw B3 x 6
012F	1	1	1	1	62030049W0	Lug
013F	3	3	3	3	51280306B0	B.H. Tapped Screw B3 x 6
017F	1	1	1	1	2140160020	Bracket (R)
019F	4	4	4	4	52040410A0	H. Head Bolt, S. F H4 x 10
020F	2	2	2	2	2139005010	Clamper
022F	1	1	1	1	2140126020	Stay
023F	2	2	2	2	51280306B0	B.H. Tapped Screw B3 x 6
024F	1	1	1	1	62030049W0	Lug
026F	1	1	1	1	62030049W0	Lug
001L	1			1	2139267110	Heatsink
001L		1	1		2139267010	Heatsink
002L	1	1	1	1	2140160070	Bracket

REF. DESIG.	Q'TY				PART NO.	DESCRIPTION
	U	C	N	A		
003L	2	2	2	2	51280306B0	B.H. Tapped Screw B3 x 6
004L	2	2	2	2	51280306B0	B.H. Tapped Screw B3 x 6
005L	1	1	1	1	2140160080	Bracket
006L	2	2	2	2	51280306B0	B.H. Tapped Screw B3 x 6
008L	2	2	2	2	2140160090	Bracket
009L	4	4	4	4	51280306B0	B.H. Tapped Screw B3 x 6
010L	4	4	4	4	2276005050	Clamper
011L	2	2	2	2	51260308B0	B.H. Tapped Screw B3 x 8
014L	2	2	2	2	2990267080	Heatsink
015L	2	2	2	2	2990115020	Spring
016L	4	4	4	4	51780314B0	B.H. Tapped Screw B3 x 14
017L	2	2	2	2	51280306B0	B.H. Tapped Screw B3 x 6
Δ L001	1				TS18505030	Power Transformer
Δ L001		1			TS18505040	Power Transformer
Δ L001			1		TS19613010	Power Transformer
Δ L001				1	TS19613020	Power Transformer
Q743	1	1	1	1	HV00010120	Varistor MV-11Y
Q744	1	1	1	1	HV00010120	Varistor MV-11Y

• [P02-99] Main P.W. Board and General Parts (PM700 ONLY)

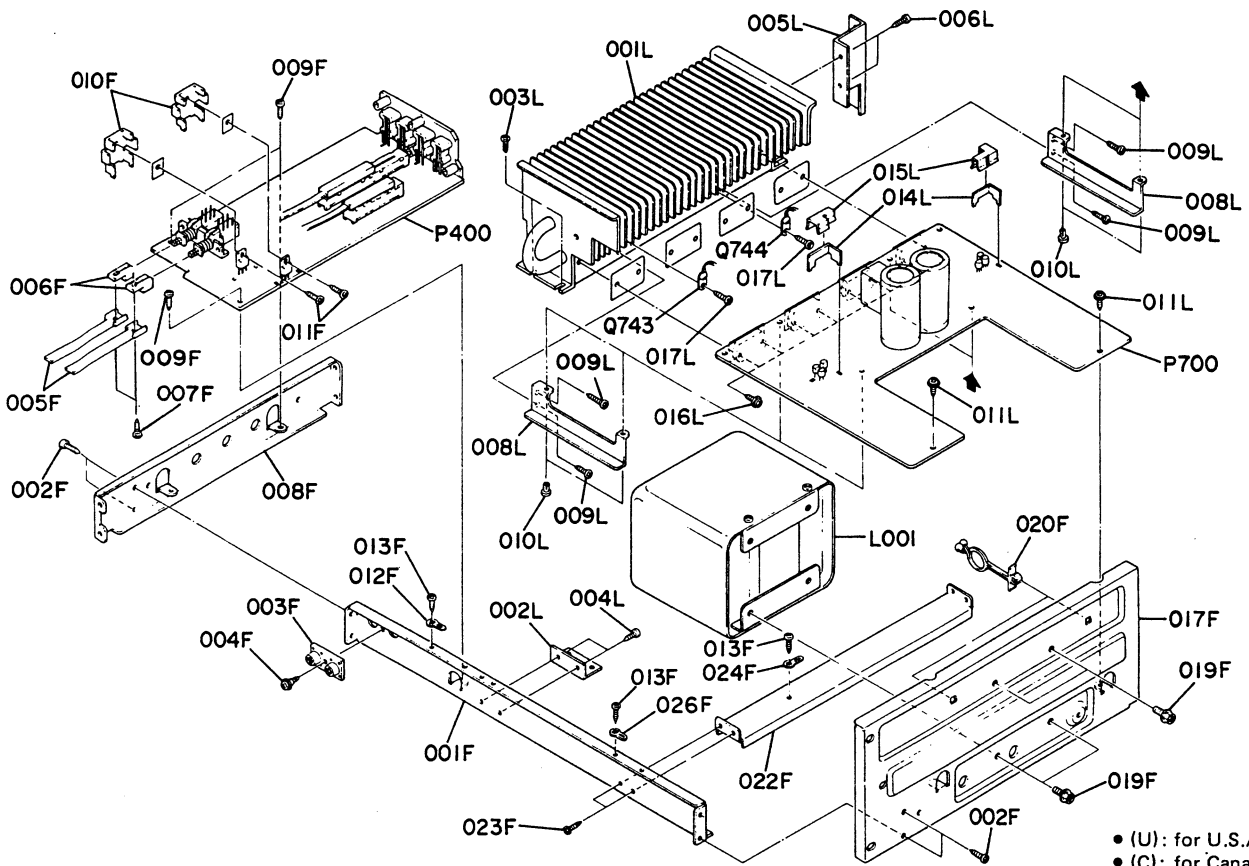

- (U): for U.S.A.
- (C): for Canada
- (N): for Europe
- (A): for Australia

REF. DESIG.	Q'TY				PART NO.	DESCRIPTION
	U	C	N	A		
(PM700, ONLY)						
001F	1	1	1	1	2140126010	Stay, Front
002F	4	4	4	4	51280308U0	B.H. Tapped Screw B3 x 8
003F	1	1	1	1	2213106010	Sustainer
004F	1	1	1	1	4367051030	Guide
005F	2	2	2	2	2140354010	Lever
006F	2	2	2	2	2891271010	Holder
007F	2	2	2	2	51280308B0	B.H. Tapped Screw B3 x 8
008F	1	1	1	1	2140160030	Bracket (L)
009F	3	3	3	3	51260308B0	B.H. Tapped Screw B3 x 8
010F	2	2	2	2	2963267020	Heatsink
011F	2	2	2	2	51280306B0	B.H. Tapped Screw B3 x 6
012F	1	1	1	1	62030049W0	Lug
013F	3	3	3	3	51280306B0	B.H. Tapped Screw B3 x 6
017F	1	1	1	1	2140160020	Bracket (R)
019F	4	4	4	4	52040410A0	H. Head Bolt, S. F H4 x 10
020F	2	2	2	2	2139005010	Clamper
022F	1	1	1	1	2140126020	Stay
023F	2	2	2	2	51280306B0	B.H. Tapped Screw B3 x 6
024F	1	1	1	1	62030049W0	Lug
026F	1	1	1	1	62030049W0	Lug
001L	1	1	1	1	2140160090	Heatsink
002L	1	1	1	1	2140160100	Bracket

REF. DESIG.	Q'TY				PART NO.	DESCRIPTION
	U	C	N	A		
003L	2	2	2	2	51280306B0	B.H. Tapped Screw B3 x 6
004L	2	2	2	2	51280306B0	B.H. Tapped Screw B3 x 6
005L	1	1	1	1	2140160110	Bracket
006L	2	2	2	2	51280306B0	B.H. Tapped Screw B3 x 6
008L	2	2	2	2	2140267010	Bracket
009L	4	4	4	4	51280306B0	B.H. Tapped Screw B3 x 6
010L	4	4	4	4	2276005050	Clamper
011L	2	2	2	2	51260308B0	B.H. Tapped Screw B3 x 8
014L	2	2	2	2	2990267080	Heatsink
015L	2	2	2	2	2990115020	Spring
016L	8	8	8	8	51780314B0	B.H. Tapped Screw B3 x 14
017L	2	2	2	2	51280306B0	B.H. Tapped Screw B3 x 6
ΔL001	1				TS19613040	Power Transformer
ΔL001		1			TS19613080	Power Transformer
ΔL001			1		TS19613050	Power Transformer
ΔL001				1	TS19613060	Power Transformer
Q743	1	1	1	1	HV00010120	Varistor MV-11Y
Q744	1	1	1	1	HV00010120	Varistor MV-11Y

• [H01-99] Packing Materials

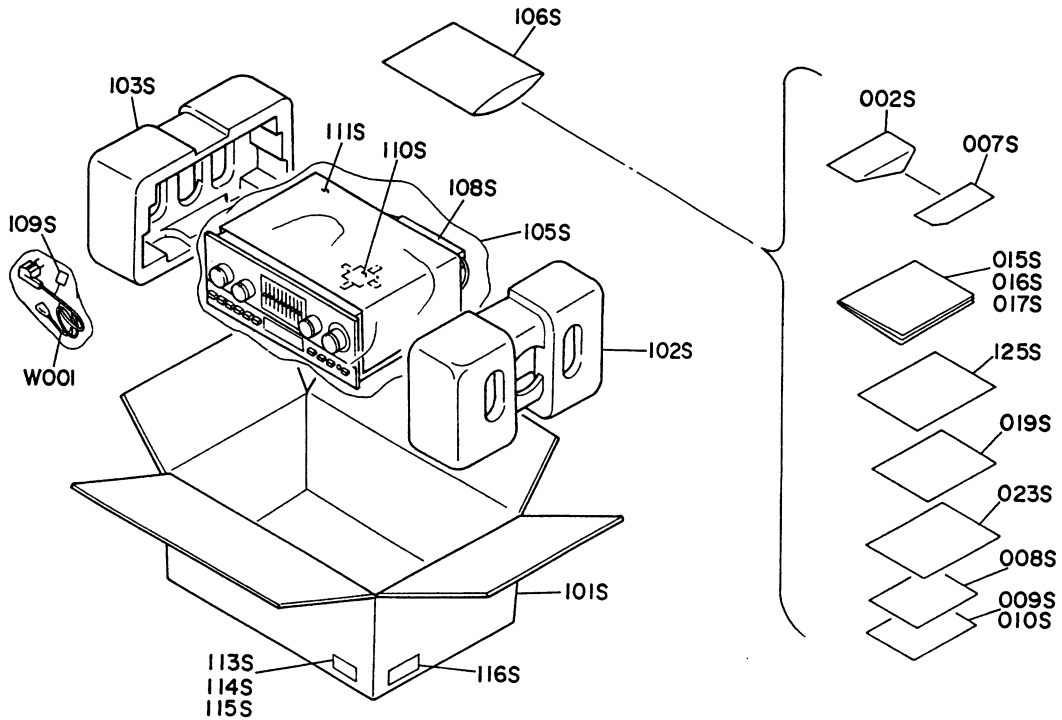

- (U): for U.S.A.
- (C): for Canada
- (N): for Europe
- (A): for Australia

REF. DESIG.	Q'TY				PART NO.	DESCRIPTION
	U	C	N	A		
002S	1				2225813010	Envelope
007S	1				9630000180	Guarantee Card
008S	1				9650000053	S. Station Card
009S	1				2818854020	Guarantee Card
010S	1				2818854040	Guarantee Card
015S	1				2128851010	Instructions
016S			1	1	2128851310	Instructions
017S		1			2128851310	Instructions
019S	1				2139851020	Instructions (PM500, Only)
019S	1				2140851020	Instructions (PM700, Only)
019S	1				2139851320	Instructions (PM500, Only)
019S	1				2140851320	Instructions (PM700, Only)
019S			1	1	2139851330	Instructions (PM500, Only)
019S			1	1	2140851330	Instructions (PM700, Only)
023S		1			2886851100	Instructions
101S	1	1			2139801010	Packing Case (PM500, Only)
101S	1	1			2140801010	Packing Case (PM700, Only)
101S			1	1	2139801030	packing Case (PM500, Only)
101S			1	1	2140801040	Packing Case (PM700, Only)
102S	1	1	1	1	2139809010	Cushion

REF. DESIG.	Q'TY				PART NO.	DESCRIPTION
	U	C	N	A		
103S	1	1	1	1	2139809020	Cushion
105S	1	1	1	1	9090909040	Polyethy Sheet
106S	1	1	1	1	9013025010	Polyethy Bag
108S	1	1	1	1	2864804010	Sleeve
109S	1	1	1	1	9560000043	Hang Tag
110S			1		2731821010	Silicagel
111S	1	1	1	1	2918107180	Sheet
113S	3				9526019010	Serial No. Card
114S		3			9526019020	Serial No. Card
115S			3	3	9526019060	Serial No. Card
116S		2			9510901020	Label
125S			1	1	2139856010	(PM500, ONLY) Circuit Diagram
125S			1	1	2140856010	(PM700, ONLY) Circuit Diagram
Δ W001			1	1	ZC01805020	A.C. Power Cord

12. ELECTRICAL PARTS LIST

- (U): for U.S.A.
- (C): for Canada
- (N): for Europe
- (A): for Australia

REF. DESIG.	Q'TY				PART NO.	DESCRIPTION
	U	C	N	A		
P400	1	1	1	1	YK21391610 ZZ21391610	P400-PHONO AMP. CIRCUIT BOARD (PM500, ONLY) P.W. Board, Phono Amp. P.W. Board Assembly
P400	1	1	1	1	YK21401610 ZZ21401610	(PM700, ONLY) P.W. Board, Phono Amp. P.W. Board Assembly
P400-CAPACITORS						
CE01	1	1	1	1	EA47505030	Elect 4.7μF 50V
CE02	1	1	1	1	EA47505030	Elect 4.7μF 50V
CE03	1	1	1	1	DD15330370	Ceramic 33pF ±5%
CE04	1	1	1	1	DD15330370	Ceramic 33pF ±5%
CE05	1	1	1	1	DD15101370	Ceramic 100pF ±5%
CE06	1	1	1	1	DD15101370	Ceramic 100pF ±5%
CE07	1	1	1	1	DD11070370	Ceramic 7pF ±0.5pF
CE08	1	1	1	1	DD11070370	Ceramic 7pF ±0.5pF
CE09	1	1	1	1	EA10701030	Elect 100μF 10V
CE10	1	1	1	1	EA10701030	Elect 100μF 10V
CE11	1	1	1	1	DD15390370	Ceramic 39pF ±5%
CE12	1	1	1	1	DD15390370	Ceramic 39pF ±5%
CE13	1	1	1	1	DD15680370	Ceramic 68pF ±5%
CE14	1	1	1	1	DD15680370	Ceramic 68pF ±5%
CE15	1	1	1	1	EA33602530	Elect 33μF 25V
CE16	1	1	1	1	EA33602530	Elect 33μF 25V
CE17	1	1	1	1	EA22702530	Elect 220μF 25V
CE18	1	1	1	1	EA22702530	Elect 220μF 25V
CJ01	1	1	1	1	DK18473320	Ceramic 0.047μF
CJ02	1	1	1	1	DK18473320	Ceramic 0.047μF
C401	1	1	1	1	EA47505030	Elect 4.7μF 50V
C402	1	1	1	1	EA47505030	Elect 4.7μF 50V
C403	1	1	1	1	DD15331370	Ceramic 330pF ±5%
C404	1	1	1	1	DD15331370	Ceramic 330pF ±5%
C409	1	1	1	1	DF15562300	Film 5600pF ±5%
C410	1	1	1	1	DF15562300	Film 5600pF ±5%
C411	1	1	1	1	DD15271370	Ceramic 270pF ±5%
C412	1	1	1	1	DD15271370	Ceramic 270pF ±5%
C413	1	1	1	1	DF15183300	Film 0.018μF ±5%
C414	1	1	1	1	DF15183300	Film 0.018μF ±5%
C415	1	1	1	1	DF15272300	Film 2700pF ±5%
C416	1	1	1	1	DF15272300	Film 2700pF ±5%
C417	1	1	1	1	EA47505030	Elect 4.7μF 50V
C418	1	1	1	1	EA47505030	Elect 4.7μF 50V
C419	1	1	1	1	DF17152300	Film 1500pF ±20%
C420	1	1	1	1	DF17152300	Film 1500pF ±20%
C421	1	1	1	1	EA47702530	Elect 470μF 25V
C422	1	1	1	1	EA47702530	Elect 470μF 25V
(PM500, ONLY)						
C405	1	1	1	1	EA22700630	Elect 220μF 6.3V
C406	1	1	1	1	EA22700630	Elect 220μF 6.3V
C407	1	1	1	1	DD11100370	Ceramic 10pF ±5%
C408	1	1	1	1	DD11100370	Ceramic 10pF ±5%
(PM700, ONLY)						
C405	1	1	1	1	EA10800630	Elect 1000μF 6.3V
C406	1	1	1	1	EA10800630	Elect 1000μF 6.3V
C407	1	1	1	1	DD15101370	Ceramic 100μF ±5%
C408	1	1	1	1	DD15101370	Ceramic 100μF ±5%
C423	1	1	1	1	DD15471370	Ceramic 470pF ±5%
C424	1	1	1	1	DD15471370	Ceramic 470pF ±5%

REF. DESIG.	Q'TY				PART NO.	DESCRIPTION
	U	C	N	A		
ΔC801	1	1	1	1	DK18103510	Ceramic 0.01μF
ΔC802	1	1	1	1	DK18103510	Ceramic 0.01μF
C803	1	1	1	1	EA47705030	Elect 470μF 50V
C804	1	1	1	1	EA47705030	Elect 470μF 50V
C805	1	1	1	1	EA47603530	Elect 47μF 35V
C806	1	1	1	1	EA47603530	Elect 47μF 35V
C809	1	1	1	1	EA47503530	Elect 4.7μF 35V
C810	1	1	1	1	EA47503530	Elect 4.7μF 35V
C811	1	1	1	1	EA47702530	Elect 470μF 25V
C812	1	1	1	1	EA47702530	Elect 470μF 25V
P400-RESISTORS (All Resistors are ±5% & ¼W)						
RE01	1	1	1	1	GD05334140	330KΩ
RE02	1	1	1	1	GD05334140	330KΩ
RE03	1	1	1	1	GD05272140	2.7KΩ
RE04	1	1	1	1	GD05272140	2.7KΩ
RE07	1	1	1	1	GD05103140	10KΩ
RE08	1	1	1	1	GD05103140	10KΩ
RE09	1	1	1	1	GD05222140	2.2KΩ
RE10	1	1	1	1	GD05222140	2.2KΩ
RE11	1	1	1	1	GD05183140	18KΩ
RE12	1	1	1	1	GD05183140	18KΩ
RE15	1	1	1	1	GD05104140	100KΩ
RE16	1	1	1	1	GD05104140	100KΩ
RE17	1	1	1	1	GD05471140	470Ω
RE18	1	1	1	1	GD05471140	470Ω
ΔRE19	1	1	1	1	GG05101140	100Ω
ΔRE20	1	1	1	1	GG05101140	100Ω
R401	1	1	1	1	GD05154140	150KΩ
R402	1	1	1	1	GD05154140	150KΩ
R403	1	1	1	1	GD05683140	68KΩ
R404	1	1	1	1	GD05683140	68KΩ
R405	1	1	1	1	GD05272140	2.7KΩ
R406	1	1	1	1	GD05272140	2.7KΩ
R407	1	1	1	1	GD05151140	150Ω
R408	1	1	1	1	GD05151140	150Ω
R409	1	1	1	1	GD05151140	150Ω
R410	1	1	1	1	GD05151140	150Ω
R413	1	1	1	1	GD05123140	12KΩ
R414	1	1	1	1	GD05123140	12KΩ
R415	1	1	1	1	GD05154140	150KΩ
R416	1	1	1	1	GD05154140	150KΩ
R417	1	1	1	1	GD05104140	100KΩ
R418	1	1	1	1	GD05104140	100KΩ
R419	1	1	1	1	GD05471140	470Ω
R420	1	1	1	1	GD05471140	470Ω
R421	1	1	1	1	GD05681140	680Ω
R422	1	1	1	1	GD05681140	680Ω
R423	1	1	1	1	GD05562140	5.6KΩ
R424	1	1	1	1	GD05562140	5.6KΩ
ΔR425	1	1	1	1	GG05101140	100Ω
ΔR426	1	1	1	1	GG05101140	100Ω

- (U): for U.S.A.
- (C): for Canada
- (N): for Europe
- (A): for Australia

REF. DESIG.	Q'TY				PART NO.	DESCRIPTION
	U	C	N	A		
						(PM500, ONLY)
R411	1	1	1	1	GD05102140	1K Ω
R412	1	1	1	1	GD05102140	1K Ω
						(PM700, ONLY)
R411	1	1	1	1	GD05152140	1.5K Ω
R412	1	1	1	1	GD05152140	1.5K Ω
R427	1	1	1	1	GD05330140	33 Ω
R428	1	1	1	1	GD05330140	33 Ω
R429	1	1	1	1	GD05101140	100 Ω
R430	1	1	1	1	GD05101140	100 Ω
R431	1	1	1	1	GD05473140	47K Ω
R432	1	1	1	1	GD05473140	47K Ω
R801	1	1	1	1	GG05122140	1.2K Ω
R802	1	1	1	1	GG05122140	1.2K Ω
R803	1	1	1	1	GD05823140	82K Ω
R804	1	1	1	1	GD05823140	82K Ω
R805	1	1	1	1	GG05681140	680 Ω
R806	1	1	1	1	GG05681140	680 Ω
R807	1	1	1	1	GD05102140	1K Ω
R808	1	1	1	1	GD05102140	1K Ω
R809	1	1	1	1	GD05332140	3.3K Ω
R810	1	1	1	1	GD05332140	3.3K Ω
R811	1	1	1	1	GD05393140	39K Ω
R812	1	1	1	1	GD05393140	39K Ω
R813	1	1	1	1	GD05123140	12K Ω
R814	1	1	1	1	GD05123140	12K Ω
R815	1	1	1	1	GD05152140	1.5K Ω
R816	1	1	1	1	GD05152140	1.5K Ω
R830	1	1	1	1	GD05100140	10 Ω
						P400-SEMICONDUCTORS
QE01	1	1	1	1	HC10034010	IC HA1457W
QE02	1	1	1	1	HC10034010	IC HA1457W
						(PM500, ONLY)
Q401	1	1	1	1	HC10034010	IC HA1457W
Q402	1	1	1	1	HC10034010	IC HA1457W
						(PM700, ONLY)
Q401	1	1	1	1	HC10035010	IC HA12017
Q402	1	1	1	1	HC10035010	IC HA12017
△Q801	1	1	1	1	HT323442A0	Transistor 2SC2344(D or E)
△Q802	1	1	1	1	HT110112A0	Transistor 2SC1011(D or E)
Q803	1	1	1	1	HT314001E0	Transistor 2SC1400(E)
Q804	1	1	1	1	HT107501E0	Transistor 2SA750(E)
Q805	1	1	1	1	HT314001E0	Transistor 2SC1400(E)
Q806	1	1	1	1	HT107501E0	Transistor 2SA750(E)
Q807	1	1	1	1	HT107501E0	Transistor 2SA750(E)
Q808	1	1	1	1	HT314001E0	Transistor 2SC1400(E)
△Q809	1	1	1	1	HD20015030	Diode DS-135D
△Q810	1	1	1	1	HD20015030	Diode DS-135D
Q811	1	1	1	1	HD30008010	Zener HZ6L(B)
Q812	1	1	1	1	HD30008010	Zener HZ6L(B)
Q813	1	1	1	1	HD20001210	Diode 1S2473, YEL
Q814	1	1	1	1	HD20001210	Diode 1S2473, YEL

REF. DESIG.	Q'TY				PART NO.	DESCRIPTION
	U	C	N	A		
						P400-MISCELLANEOUS
JJ01	1	1	1	1	YT02040260	Terminal, Phono 1/2 In
JJ02	1	1	1	1	YT02040260	Terminal, Tuner/Aux In
SJ07	1	1	1	1	SP02020260	Push Switch, Tape Monitor
						(PM500, ONLY)
SJ02	1	1	1	1	SR00040060	Rotary Switch
SJ03	1	1	1	1	SS04040010	Slide Switch
SJ05	1	1	1	1	SR00030030	Rotary Switch
SJ06	1	1	1	1	SS04040010	Slide Switch
						(PM700, ONLY)
SJ02	1	1	1	1	SR00050020	Rotary Switch
SJ03	1	1	1	1	SS08060010	Slide Switch
SJ05	1	1	1	1	SR00060010	Rotary Switch
SJ06	1	1	1	1	SS04060020	Slide Switch
						P700-MIAN AMP. CIRCUIT BOARD
						(PM500, ONLY)
P700	1	1	1	1	YK21392510	P.W. Board, Main Amp.
					ZZ21392510	P.W. Board Assembly
					ZZ21398510	P.W. Board Assembly
						(PM700, ONLY)
P700	1	1	1	1	YK21402510	P.W. Board, Main Amp.
					ZZ21402510	P.W. Board Assembly
					ZZ21408510	P.W. Board Assembly
						P700-CAPACITORS
△CN05	1	1	1	1	DK18103510	Ceramic 0.0 μ F
△CN06	1	1	1	1	DK18103510	Ceramic 0.0 μ F
△CN07	1	1	1	1	DK18103510	Ceramic 0.0 μ F
△CN08	1	1	1	1	DK18103510	Ceramic 0.0 μ F
△CN09	1	1	1	1	DK18103510	Ceramic 0.0 μ F
△CN10	1	1	1	1	DK18103510	Ceramic 0.0 μ F
CN11	1	1	1	1	EA47601630	Elect 4 μ F 16V
CN12	1	1	1	1	EA33505030	Elect 3.3 μ F 50V
CN13	1	1	1	1	EA47602530	Elect 4 μ F 25V
CN15	1	1	1	1	EA22601630	Elect 2 μ F 16V
CN16	1	1	1	1	DD15271370	Ceramic 27 μ F \pm 5%
CN17	1	1	1	1	EA47405030	Elect 0.4 μ F 50V
CX31	1	1	1	1	EA10602530	Elect 10 μ F 25V
CX32	1	1	1	1	EA10602530	Elect 10 μ F 25V
CX33	1	1	1	1	EA10602530	Elect 10 μ F 25V
CX34	1	1	1	1	EA10602530	Elect 10 μ F 25V
CX35	1	1	1	1	EA22505030	Elect 2.2 μ F 50V
CX36	1	1	1	1	EA22505030	Elect 2.2 μ F 50V
C701	1	1	1	1	EA47505030	Elect 4.7 μ F 50V
C702	1	1	1	1	EA47505030	Elect 4.7 μ F 50V
C703	1	1	1	1	DD15101370	Ceramic 10 μ F \pm 5%
C704	1	1	1	1	DD15101370	Ceramic 10 μ F \pm 5%
C705	1	1	1	1	DD15221370	Ceramic 22 μ F \pm 5%
C706	1	1	1	1	DD15221370	Ceramic 22 μ F \pm 5%
C707	1	1	1	1	DD15221370	Ceramic 22 μ F \pm 5%
C708	1	1	1	1	DD15221370	Ceramic 22 μ F \pm 5%
C709	1	1	1	1	DK16101500	Ceramic 10 μ F \pm 10%
C710	1	1	1	1	DK16101500	Ceramic 10 μ F \pm 10%

- (U): for U.S.A.
- (C): for Canada
- (N): for Europe
- (A): for Australia

REF. DESIG.	Q'TY				PART NO.	DESCRIPTION
	U	C	N	A		
C711	1	1	1	1	DF17473300	Film 0.047μF ±20%
C712	1	1	1	1	DF17473300	Film 0.047μF ±20%
C717	1	1	1	1	DD11100370	Ceramic 10pF ±5%
C718	1	1	1	1	DD11100370	Ceramic 10pF ±5%
C719	1	1	1	1	EA10602530	Elect 10μF 25V
C720	1	1	1	1	EA10602530	Elect 10μF 25V
C721	1	1	1	1	DF17473520	Film 0.047μF ±20%
C722	1	1	1	1	DF17473520	Film 0.047μF ±20%
(PM500, ONLY)						
C723	1	1	1	1	EB82805010	Elect 8200μF 50V
C724	1	1	1	1	EB82805010	Elect 8200μF 50V
(PM700, ONLY)						
C723	1	1	1	1	EB10906310	Elect 10000μF 63V
C724	1	1	1	1	EB10906310	Elect 10000μF 63V
P700-RESISTORS (All Resistors are ±5% & ¼W)						
RN01	1	1	1	1	GD05102140	1KΩ
RN02	1	1	1	1	GD05104140	100KΩ
RN03	1	1	1	1	GD05393140	39KΩ
RN04	1	1	1	1	GD05473140	47KΩ
RN05	1	1	1	1	GD05473140	47KΩ
RN06	1	1	1	1	GD05823140	82KΩ
RN07	1	1	1	1	GD05823140	82KΩ
RN08	1	1	1	1	GD05223140	22KΩ
RN09	1	1	1	1	GG05183120	18KΩ ½W
RN10	1	1	1	1	GD05274140	270KΩ
RN11	1	1	1	1	GG05183120	18KΩ ½W
RN12	1	1	1	1	GA05471010	470Ω 1W
RN16	1	1	1	1	GD05563140	56KΩ
RN17	1	1	1	1	GD05333140	33KΩ
(PM500, ONLY)						
RX31	1	1	1	1	GD05103140	10KΩ
RX32	1	1	1	1	GD05103140	10KΩ
(PM700, ONLY)						
RX31	1	1	1	1	GD05123140	12KΩ
RX32	1	1	1	1	GD05123140	12KΩ
RX33	1	1	1	1	GD05182140	1.8KΩ
RX34	1	1	1	1	GD05182140	1.8KΩ
RX35	1	1	1	1	GD05121140	120Ω
RX36	1	1	1	1	GD05121140	120Ω
RX37	1	1	1	1	GD05272140	2.7KΩ
RX38	1	1	1	1	GD05272140	2.7KΩ
RX39	1	1	1	1	RA02030060	20KΩ (B) Trimming
RX40	1	1	1	1	RA02030060	20KΩ (B) Trimming
RX41	1	1	1	1	GD05274140	270KΩ
RX42	1	1	1	1	GD05274140	270KΩ
RX43	1	1	1	1	GD05682140	6.8KΩ
RX44	1	1	1	1	GD05682140	6.8KΩ
RX45	1	1	1	1	GD05822140	8.2KΩ
RX46	1	1	1	1	GD05822140	8.2KΩ
RX47	1	1	1	1	GD05562140	5.6KΩ
RX48	1	1	1	1	GD05562140	5.6KΩ
RX49	1	1	1	1	GD05821140	820Ω
RX50	1	1	1	1	GD05821140	820Ω
RX51	1	1	1	1	GD05103140	10KΩ
RX52	1	1	1	1	GD05103140	10KΩ

REF. DESIG.	Q'TY				PART NO.	DESCRIPTION
	U	C	N	A		
RX53	1	1	1	1	HH00008030	Thermistor STD-1000
RX54	1	1	1	1	HH00008030	Thermistor STD-1000
RX55	1	1	1	1	GD05103140	10KΩ
RX56	1	1	1	1	GD05103140	10KΩ
RX57	1	1	1	1	GD05103140	10KΩ
RX58	1	1	1	1	GD05103140	10KΩ
ΔRX59	1	1	1	1	GG05101140	100Ω
RX60	1	1	1	1	GD05562140	5.6KΩ
(PM500, ONLY)						
R701	1	1	1	1	GD05393140	39KΩ
R702	1	1	1	1	GD05393140	39KΩ
R703	1	1	1	1	GD05471140	470Ω
R704	1	1	1	1	GD05471140	470Ω
R705	1	1	1	1	GD05182140	1.8KΩ
R706	1	1	1	1	GD05182140	1.8KΩ
R707	1	1	1	1	GD05182140	1.8KΩ
R708	1	1	1	1	GD05182140	1.8KΩ
R709	1	1	1	1	GD05151140	150Ω
R710	1	1	1	1	GD05151140	150Ω
R711	1	1	1	1	GD05333140	33KΩ
R712	1	1	1	1	GD05333140	33KΩ
R713	1	1	1	1	GD05104140	100KΩ
R714	1	1	1	1	GD05104140	100KΩ
R717	1	1	1	1	GD05182140	1.8KΩ
R718	1	1	1	1	GD05182140	1.8KΩ
R719	1	1	1	1	GD05182140	1.8KΩ
R720	1	1	1	1	GD05182140	1.8KΩ
R721	1	1	1	1	GD05182140	1.8KΩ
R722	1	1	1	1	GD05182140	1.8KΩ
R723	1	1	1	1	GD05182140	1.8KΩ
R724	1	1	1	1	GD05182140	1.8KΩ
R725	1	1	1	1	GD05151140	150Ω
R726	1	1	1	1	GD05151140	150Ω
R727	1	1	1	1	GG05271140	270Ω
R728	1	1	1	1	GG05271140	270Ω
R729	1	1	1	1	GG05271140	270Ω
R730	1	1	1	1	GG05271140	270Ω
R731	1	1	1	1	GD05683140	68KΩ
R732	1	1	1	1	GD05683140	68KΩ
R733	1	1	1	1	GD05683140	68KΩ
R734	1	1	1	1	GD05683140	68KΩ
R737	1	1	1	1	GD05272140	2.7KΩ
R738	1	1	1	1	GD05272140	2.7KΩ
R739	1	1	1	1	GD05821140	820Ω
R740	1	1	1	1	GD05821140	820Ω
R741	1	1	1	1	RA01020320	1KΩ (B) Trimming
R742	1	1	1	1	RA01020320	1KΩ (B) Trimming
R743	1	1	1	1	GG05100140	10Ω
R744	1	1	1	1	GG05100140	10Ω
R745	1	1	1	1	GG05100140	10Ω
R746	1	1	1	1	GG05100140	10Ω
R747	1	1	1	1	GD05223140	22KΩ
R748	1	1	1	1	GD05223140	22KΩ
R749	1	1	1	1	GG05221140	220Ω
R750	1	1	1	1	GG05221140	220Ω
R751	1	1	1	1	GG05221140	220Ω
R752	1	1	1	1	GG05221140	220Ω
R753	1	1	1	1	GG05222140	2.2KΩ
R754	1	1	1	1	GG05222140	2.2KΩ

- (U): for U.S.A.
- (C): for Canada
- (N): for Europe
- (A): for Australia

REF. DESIG.	Q'TY				PART NO.	DESCRIPTION
	U	C	N	A		
R755	1	1	1	1	GG05151120	150Ω
R756	1	1	1	1	GG05151120	150Ω
R757	1	1	1	1	GG05151120	150Ω
R758	1	1	1	1	GG05151120	150Ω
R759	1	1	1	1	GD05033140	3.3Ω
R760	1	1	1	1	GD05033140	3.3Ω
R761	1	1	1	1	GD05033140	3.3Ω
R762	1	1	1	1	GD05033140	3.3Ω
R763	1	1	1	1	GO10332050	0.33Ω ±10% 5W
R764	1	1	1	1	GO10332050	0.33Ω ±10% 5W
R765	1	1	1	1	GO10332050	0.33Ω ±10% 5W
R766	1	1	1	1	GO10332050	0.33Ω ±10% 5W
R767	1	1	1	1	GD05331140	330Ω
R768	1	1	1	1	GD05331140	330Ω
R769	1	1	1	1	GD05682140	6.8KΩ
R770	1	1	1	1	GD05682140	6.8KΩ
R771	1	1	1	1	GD05152140	1.5KΩ
R772	1	1	1	1	GD05663140	56KΩ
R773	1	1	1	1	GA05100030	10Ω 3W
R774	1	1	1	1	GA05100030	10Ω 3W
R775	1	1	1	1	RC10022120	2.2Ω ±10% ½W
R776	1	1	1	1	RC10022120	2.2Ω ±10% ½W
R777	1	1	1	1	GA05682010	6.8KΩ 1W
R779	1	1	1	1	RA02030150	20KΩ (B) Trimming
R780	1	1	1	1	RA02030150	20KΩ (B) Trimming
R781	1	1	1	1	GD05100140	10Ω
R782	1	1	1	1	GD05100140	10Ω
R783	1	1	1	1	GD05393140	39KΩ
R784	1	1	1	1	GD05393140	39KΩ
R785	1	1	1	1	GA05682010	6.8KΩ 1W
R786	1	1	1	1	GD05151140	150Ω
R787	1	1	1	1	GD05151140	150Ω
R715	1	1	1	1	GD05152140	(PM500, ONLY) 1.5KΩ
R716	1	1	1	1	GD05152140	1.5KΩ
R715	1	1	1	1	GD05122140	(PM700, ONLY) 1.2KΩ
R716	1	1	1	1	GD05122140	1.2KΩ
△QN01	1	1	1	1	HD20011290	Diode S3V-20
△QN02	1	1	1	1	HD20011290	Diode S3V-20
△QN03	1	1	1	1	HD20011290	Diode S3V-20
△QN04	1	1	1	1	HD20011290	Diode S3V-20
△QN05	1	1	1	1	HD20015030	Diode DS-135D
△QN06	1	1	1	1	HD20015030	Diode DS-135D
QN07	1	1	1	1	HC10042050	IC TA7317P
QN08	1	1	1	1	HD20003210	Diode 1S2471
QX05	1	1	1	1	HD20001210	Diode 1S2473
QX06	1	1	1	1	HD20001210	Diode 1S2473
QX07	1	1	1	1	HD20001210	Diode 1S2473
QX08	1	1	1	1	HD20001210	Diode 1S2473
QX09	1	1	1	1	HT107501E0	Transistor 2SA750(E)
QX10	1	1	1	1	HT107501E0	Transistor 2SA750(E)
QX11	1	1	1	1	HT314001E0	Transistor 2SC1400(E)
QX12	1	1	1	1	HT314001E0	Transistor 2SC1400(E)
QX13	1	1	1	1	HT314001E0	Transistor 2SC1400(E)
QX14	1	1	1	1	HD30047090	Zener WZ-192

REF. DESIG.	Q'TY				PART NO.	DESCRIPTION
	U	C	N	A		
Q701	1	1	1	1	HT322592G0	Transistor 2SC2259(F or G)
Q702	1	1	1	1	HT322592G0	Transistor 2SC2259(F or G)
Q703	1	1	1	1	HT107501E0	Transistor 2SA750(E)
Q704	1	1	1	1	HT107501E0	Transistor 2SA750(E)
Q705	1	1	1	1	HT107501E0	Transistor 2SA750(E)
Q706	1	1	1	1	HT107501E0	Transistor 2SA750(E)
Q707	1	1	1	1	HT107501E0	Transistor 2SA750(E)
Q708	1	1	1	1	HT107501E0	Transistor 2SA750(E)
Q709	1	1	1	1	HT314001E0	Transistor 2SC1400(E)
Q710	1	1	1	1	HT314001E0	Transistor 2SC1400(E)
Q711	1	1	1	1	HT109702A0	Transistor 2SA970(GR or BL)
Q712	1	1	1	1	HT109702A0	Transistor 2SA970(GR or BL)
Q713	1	1	1	1	HT322402A0	Transistor 2SC2240(GR or BL)
Q714	1	1	1	1	HT322402A0	Transistor 2SC2240(GR or BL)
Q715	1	1	1	1	HT314001E0	Transistor 2SC1400(E)
Q716	1	1	1	1	HT314001E0	Transistor 2SC1400(E)
Q717	1	1	1	1	HT322292A0	Transistor 2SC2229(O or Y)
Q718	1	1	1	1	HT322292A0	Transistor 2SC2229(O or Y)
Q719	1	1	1	1	HT109492A0	Transistor 2SA949(Q or Y)
Q720	1	1	1	1	HT109492A0	Transistor 2SA949(Q or Y)
Q721	1	1	1	1	HT325913A0	Transistor 2SC2591(P, Q or R)
Q722	1	1	1	1	HT325913A0	Transistor 2SC2591(P, Q or R)
Q729	1	1	1	1	HT314001E0	Transistor 2SC1400(E)
Q730	1	1	1	1	HT314001E0	Transistor 2SC1400(E)
Q731	1	1	1	1	HT107501E0	Transistor 2SA750(E)
Q733	1	1	1	1	HD20001210	Diode 1S2473, YEL
Q734	1	1	1	1	HD20001210	Diode 1S2473, YEL
Q735	1	1	1	1	HD20001210	Diode 1S2473, YEL
Q736	1	1	1	1	HD20001210	Diode 1S2473, YEL
Q737	1	1	1	1	HD20001210	Diode 1S2473, YEL
Q738	1	1	1	1	HD20001210	Diode 1S2473, YEL
Q739	1	1	1	1	HD20008210	Diode 1S2471F, WHT
Q740	1	1	1	1	HD20008210	Diode 1S2471F, WHT
Q741	1	1	1	1	HD20008210	Diode 1S2471F, WHT
Q742	1	1	1	1	HD20008210	Diode 1S2471F, WHT
Q743	1	1	1	1	HV00010120	Varistor MV-11Y
Q744	1	1	1	1	HV00010120	Varistor MV-11Y
Q745	1	1	1	1	HD20001210	Diode 1S2473, YEL
Q746	1	1	1	1	HD20001210	Diode 1S2473, YEL
Q747	1	1	1	1	HD20001210	Diode 1S2473, YEL
Q748	1	1	1	1	HD20001210	Diode 1S2473, YEL
Q749	1	1	1	1	HD20015030	Diode DS135D
Q750	1	1	1	1	HD20015030	Diode DS135D
Q751	1	1	1	1	HD20015030	Diode DS135D
Q752	1	1	1	1	HD20015030	Diode DS135D
Q753	1	1	1	1	HD20003210	Diode 1S2471, BLK
Q754	1	1	1	1	HD20003210	Diode 1S2471, BLK
Q755	1	1	1	1	HD20001210	Diode 1S2473, YEL
Q756	1	1	1	1	HD20001210	Diode 1S2473, YEL
Q723	1	1	1	1	HT111113A0	(PM500, ONLY) Transistor 2SA1111(P, Q or R)
Q724	1	1	1	1	HT111113A0	Transistor 2SA1111(P, Q or R)
△Q725	1	1	1	1	HT326812A0	Transistor 2SC2681(Q or R)
△Q726	1	1	1	1	HT326812A0	Transistor 2SC2681(Q or R)
△Q727	1	1	1	1	HT111412A0	Transistor 2SA1141(Q or R)
△Q728	1	1	1	1	HT111412A0	Transistor 2SA1141(Q or R)
Q723	1	1	1	1	HT111113A0	(PM700, ONLY) Transistor 2SA1111(P, Q or R)
Q724	1	1	1	1	HT111113A0	Transistor 2SA1111(P, Q or R)
△Q725	1	1	1	1	HT325882A0	Transistor 2SC2588A(Q or R)
△Q726	1	1	1	1	HT325882A0	Transistor 2SC2588A(Q or R)
△Q727	1	1	1	1	HT111082A0	Transistor 2SA1108A(Q or R)
△Q728	1	1	1	1	HT111082A0	Transistor 2SA1108A(Q or R)

- (U): for U.S.A.
- (C): for Canada
- (N): for Europe
- (A): for Australia

REF. DESIG.	Q'TY				PART NO.	DESCRIPTION
	U	C	N	A		
FN01	1				FS1010080	Fuse 1A, UL
FN01		1			FS1010080	Fuse 1A, Semko
FN02	1				FS1010080	Fuse 1A, UL
FN02			1		FS1010080	Fuse 1A, Semko
JN01				4	YJ08000170	Jack, Fuse Clip
JN04						
JN01				4	YJ08000270	Jack, Fuse Clip
JN04						
LN01	1	1	1	1	LY20240150	Relay JC-2A DC24V
L701	1	1	1	1	LL23915120	Coil
L702	1	1	1	1	LL23915120	Coil
						PF00-GRAPHIC EQ AMP. CIRCUIT BOARD (PM500, ONLY)
PF00	1	1	1	1	YK21391640	P.W. Board, Graphic EQ Amp.
	1	1	1	1	ZZ21401640	P.W. Board Assembly
						(PM700, ONLY)
PF00	1	1	1	1	YK21401640	P.W. Board, Graphic EQ Amp.
	1	1	1	1	ZZ21401640	P.W. Board Assembly
						PF00-CAPACITORS
CF01	1	1	1	1	DD15330370	Ceramic 33pF ±5%
CF02	1	1	1	1	DD15330370	Ceramic 33pF ±5%
CF03	1	1	1	1	DD15331370	Ceramic 330pF ±5%
CF04	1	1	1	1	DD15331370	Ceramic 330pF ±5%
CF05	1	1	1	1	EA10701030	Elect 100µF 10V
CF06	1	1	1	1	EA10701030	Elect 100µF 10V
CF07	1	1	1	1	EA10701030	Elect 100µF 10V
CF08	1	1	1	1	EA10701030	Elect 100µF 10V
CF11	1	1	1	1	EA22702530	Elect 220µF 25V
CF12	1	1	1	1	EA22702530	Elect 220µF 25V
CF31	1	1	1	1	EA22505030	Elect 2.2µF 50V
CF32	1	1	1	1	EA22505030	Elect 2.2µF 50V
CF33	1	1	1	1	EA47405030	Elect 0.47µF 50V
CF34	1	1	1	1	EA47405030	Elect 0.47µF 50V
CF35	1	1	1	1	DF17154300	Film 0.15µF ±20%
CF36	1	1	1	1	DF17154300	Film 0.15µF ±20%
CF37	1	1	1	1	DF17333300	Film 0.033µF ±20%
CF38	1	1	1	1	DF17333300	Film 0.033µF ±20%
CF39	1	1	1	1	DF17822300	Film 8200pF ±20%
CF40	1	1	1	1	DF17822300	Film 8200pF ±20%
CF41	1	1	1	1	EA10405030	Elect 0.1µF 50V
CF42	1	1	1	1	EA10405030	Elect 0.1µF 50V
CF43	1	1	1	1	DF17223300	Film 0.022µF ±20%
CF44	1	1	1	1	DF17223300	Film 0.022µF ±20%
CF45	1	1	1	1	DF17562300	Film 5600pF ±20%
CF46	1	1	1	1	DF17562300	Film 5600pF ±20%
CF47	1	1	1	1	DF17152300	Film 1500pF ±20%
CF48	1	1	1	1	DF17152300	Film 1500pF ±20%
CF49	1	1	1	1	DD15391370	Ceramic 390pF ±5%
CF50	1	1	1	1	DD15391370	Ceramic 390pF ±5%

REF. DESIG.	Q'TY				PART NO.	DESCRIPTION
	U	C	N	A		
CF51	1	1	1	1	DD11100370	Ceramic 10pF ±0.5pF
CF52	1	1	1	1	DD11100370	Ceramic 10pF ±0.5pF
CF53	1	1	1	1	DD11100370	Ceramic 10pF ±0.5pF
CF54	1	1	1	1	DD11100370	Ceramic 10pF ±0.5pF
CF55	1	1	1	1	DD11100370	Ceramic 10pF ±0.5pF
CF56	1	1	1	1	DD11100370	Ceramic 10pF ±0.5pF
CF57	1	1	1	1	DD11100370	Ceramic 10pF ±0.5pF
CF58	1	1	1	1	DD11100370	Ceramic 10pF ±0.5pF
CF59	1	1	1	1	DD11100370	Ceramic 10pF ±0.5pF
CF60	1	1	1	1	DD11100370	Ceramic 10pF ±0.5pF
						PF00-RESISTORS (All Resistors are ±5% & ¼W)
RF01	1	1	1	1	GD05223140	22KΩ
RF02	1	1	1	1	GD05223140	22KΩ
RF03	1	1	1	1	GD05392140	3.9KΩ
RF04	1	1	1	1	GD05392140	3.9KΩ
RF05	1	1	1	1	GD05392140	3.9KΩ
RF06	1	1	1	1	GD05392140	3.9KΩ
RF07	1	1	1	1	GD05103140	10KΩ
RF08	1	1	1	1	GD05103140	10KΩ
ΔRF09	1	1	1	1	GG05101140	100Ω
ΔRF10	1	1	1	1	GG05101140	100Ω
RF11	1	1	1	1	GD05224140	220KΩ
RF12	1	1	1	1	GD05224140	220KΩ
RF31	1	1	1	1	GD05102140	1KΩ
RF32	1	1	1	1	GD05102140	1KΩ
RF33	1	1	1	1	GD05102140	1KΩ
RF34	1	1	1	1	GD05102140	1KΩ
RF35	1	1	1	1	GD05102140	1KΩ
RF36	1	1	1	1	GD05102140	1KΩ
RF37	1	1	1	1	GD05102140	1KΩ
RF38	1	1	1	1	GD05102140	1KΩ
RF39	1	1	1	1	GD05102140	1KΩ
RF40	1	1	1	1	GD05102140	1KΩ
RF41	1	1	1	1	GD05473140	47KΩ
RF42	1	1	1	1	GD05473140	47KΩ
RF43	1	1	1	1	GD05473140	47KΩ
RF44	1	1	1	1	GD05473140	47KΩ
RF45	1	1	1	1	GD05473140	47KΩ
RF46	1	1	1	1	GD05473140	47KΩ
RF47	1	1	1	1	GD05473140	47KΩ
RF48	1	1	1	1	GD05473140	47KΩ
RF49	1	1	1	1	GD05473140	47KΩ
RF50	1	1	1	1	GD05473140	47KΩ
RF51	1	1	1	1	GD05101140	100Ω
RF52	1	1	1	1	GD05101140	100Ω
RF53	1	1	1	1	GD05101140	100Ω
RF54	1	1	1	1	GD05101140	100Ω
RF55	1	1	1	1	GD05101140	100Ω
RF56	1	1	1	1	GD05101140	100Ω
RF57	1	1	1	1	GD05101140	100Ω
RF58	1	1	1	1	GD05101140	100Ω
RF59	1	1	1	1	GD05101140	100Ω
RF60	1	1	1	1	GD05101140	100Ω
RF61	1	1	1	1	GD05472140	4.7KΩ
RF62	1	1	1	1	GD05472140	4.7KΩ
RF63	1	1	1	1	GD05472140	4.7KΩ

- (U): for U.S.A.
- (C): for Canada
- (N): for Europe
- (A): for Australia

REF. DESIG.	Q'TY				PART NO.	DESCRIPTION
	U	C	N	A		
RF64	1	1	1	1	GD05472140	4.7K Ω
RF65	1	1	1	1	GD05472140	4.7K Ω
RF66	1	1	1	1	GD05472140	4.7K Ω
RF67	1	1	1	1	GD05472140	4.7K Ω
RF68	1	1	1	1	GD05472140	4.7K Ω
RF69	1	1	1	1	GD05472140	4.7K Ω
RF70	1	1	1	1	GD05472140	4.7K Ω
PF00-SEMICONDUCTORS						
QF01	1	1	1	1	HC10034010	IC HA1457W
QF02	1	1	1	1	HC10034010	IC HA1457W
QF03	1	1	1	1	HT314001E0	Transistor 2SC1400(E)
QF04	1	1	1	1	HT314001E0	Transistor 2SC1400(E)
QF05	1	1	1	1	HT314001E0	Transistor 2SC1400(E)
QF06	1	1	1	1	HT314001E0	Transistor 2SC1400(E)
QF07	1	1	1	1	HT314001E0	Transistor 2SC1400(E)
QF08	1	1	1	1	HT314001E0	Transistor 2SC1400(E)
QF09	1	1	1	1	HT314001E0	Transistor 2SC1400(E)
QF10	1	1	1	1	HT314001E0	Transistor 2SC1400(E)
QF11	1	1	1	1	HT314001E0	Transistor 2SC1400(E)
QF12	1	1	1	1	HT314001E0	Transistor 2SC1400(E)
PF01-GRAPHIC VR CIRCUIT BOARD (PM500, ONLY)						
PF01	1	1	1	1	YK21391630	P.W. Board, Graphic VR
	1	1	1	1	ZZ21391630	P.W. Board Assembly
RF21	1	1	1	1	RS05030340	50K Ω (B) x 2 Variable
RF22	1	1	1	1	RS05030340	50K Ω (B) x 2 Variable
RF23	1	1	1	1	RS05030340	50K Ω (B) x 2 Variable
RF24	1	1	1	1	RS05030340	50K Ω (B) x 2 Variable
RF25	1	1	1	1	RS05030340	50K Ω (B) x 2 Variable
(PM700, ONLY)						
PF01	1	1	1	1	YK21401630	P.W. Board, Graphic VR
	1	1	1	1	ZZ21401630	P.W. Board Assembly
RF21	1	1	1	1	RX05030170	50K Ω (B) Variable
RF22	1	1	1	1	RX05030170	50K Ω (B) Variable
RF23	1	1	1	1	RX05030170	50K Ω (B) Variable
RF24	1	1	1	1	RX05030170	50K Ω (B) Variable
RF25	1	1	1	1	RX05030170	50K Ω (B) Variable
RF26	1	1	1	1	RX05030170	50K Ω (B) Variable
RF27	1	1	1	1	RX05030170	50K Ω (B) Variable
RF28	1	1	1	1	RX05030170	50K Ω (B) Variable
RF29	1	1	1	1	RX05030170	50K Ω (B) Variable
RF30	1	1	1	1	RX05030170	50K Ω (B) Variable
PG00-VOLUME/BALANCE CIRCUIT BOARD						
PG00	1	1	1	1	YK21392550	P.W. Board, Volume/Balance
	1	1	1	1	ZZ21392550	P.W. Board Assembly
PG00-CAPACITORS						
CF01	1	1	1	1	DD15391370	Ceramic 390 μ F \pm 5%
CF02	1	1	1	1	DD15391370	Ceramic 390 μ F \pm 5%
PG00-RESISTORS						
RG01	1	1	1	1	RM01040300	100K Ω Variable
RG02	1	1	1	1	RM01040310	100K Ω (B) Variable
RG03	1	1	1	1	GD05823140	82K Ω \pm 5% $\frac{1}{4}$ W
RG04	1	1	1	1	GD05823140	82K Ω \pm 5% $\frac{1}{4}$ W
RG05	1	1	1	1	GD05822140	8.2K Ω \pm 5% $\frac{1}{4}$ W
RG06	1	1	1	1	GD05822140	8.2K Ω \pm 5% $\frac{1}{4}$ W

REF. DESIG.	Q'TY				PART NO.	DESCRIPTION
	U	C	N	A		
PG01-LOUDNESS CIRCUIT BOARD						
PG01	1	1	1	1	YK21391660	P.W. Board, Loudness
	1	1	1	1	ZZ21391660	P.W. Board Assembly
CG03	1	1	1	1	DF17683300	Film Cap. 0.068 μ F \pm 20%
CG04	1	1	1	1	DF17683300	Film Cap. 0.068 μ F \pm 20%
SG01	1	1	1	1	SP02010240	Push Switch, Loudness
PH00-FILTER CIRCUIT BOARD (PM500, ONLY)						
PH00	1	1	1	1	YK21391650	P.W. Board, Filter
	1	1	1	1	ZZ21391650	P.W. Board Assembly
PH00-CAPACITORS						
CH01	1	1	1	1	EA22405030	Elect 0.22 μ F 50V
CH02	1	1	1	1	EA22405030	Elect 0.22 μ F 50V
PH00-RESISTORS						
RH01	1	1	1	1	GD05222140	2.2K Ω \pm 5% $\frac{1}{4}$ W
RH02	1	1	1	1	GD05222140	2.2K Ω \pm 5% $\frac{1}{4}$ W
RH03	1	1	1	1	GD05334140	330K Ω \pm 5% $\frac{1}{4}$ W
RH04	1	1	1	1	GD05334140	330K Ω \pm 5% $\frac{1}{4}$ W
PH00-SWITCH						
SH01	1	1	1	1	SP02030100	Push Switch
(PM700, ONLY)						
PH00	1	1	1	1	YK21401650	P.W. Board, Filter
	1	1	1	1	ZZ21401650	P.W. Board Assembly
PH00-CAPACITORS						
CH01	1	1	1	1	DF17472300	Film 4700pF \pm 20%
CH02	1	1	1	1	DF17472300	Film 4700pF \pm 20%
CH03	1	1	1	1	EA22405030	Elect 0.22 μ F 50V
CH04	1	1	1	1	EA22405030	Elect 0.22 μ F 50V
PH00-RESISTORS (All Resistors are \pm5% & $\frac{1}{4}$W)						
RH01	1	1	1	1	GD05222140	2.2K Ω
RH02	1	1	1	1	GD05222140	2.2K Ω
RH03	1	1	1	1	GD05182140	1.8K Ω
RH04	1	1	1	1	GD05182140	1.8K Ω
RH05	1	1	1	1	GD05224140	220K Ω
RH06	1	1	1	1	GD05224140	220K Ω
RH07	1	1	1	1	GD05334140	330K Ω
RH08	1	1	1	1	GD05334140	330K Ω
PH00-SWITCH						
SH01	1	1	1	1	SP02040070	Push Switch

- (U): for U.S.A.
- (C): for Canada
- (N): for Europe
- (A): for Australia

REF. DESIG.	Q'TY				PART NO.	DESCRIPTION
	U	C	N	A		
PJ00	1	1	1	1	YK21391620	PJ00-TAPE IN/OUT CIRCUIT BOARD (PM500, ONLY) P.W. Board, Tape IN/OUT
	1	1			ZZ21391620	P.W. Board Assembly
			1	1	ZZ21398620	P.W. Board Assembly
PJ00	1	1	1	1	YK21401620	(PM700, ONLY) P.W. Board, Tape IN/OUT
	1	1			ZZ21401620	P.W. Board Assembly
			1	1	ZZ21408620	P.W. Board Assembly
CJ03	1	1	1	1	DK18473320	PJ00-CAPACITORS Ceramic 0.047μF
CJ04	1	1	1	1	DK18473320	Ceramic 0.047μF
						PJ00-RESISTORS (All Resistors are ±5% & ¼W)
RJ01			1	1	GD05394140	390KΩ
RJ02			1	1	GD05394140	390KΩ
RJ03			1	1	GD05104140	100KΩ
RJ04			1	1	GD05104140	100KΩ
RJ05			1	1	GD05394140	390KΩ
RJ06			1	1	GD05394140	390KΩ
RJ07			1	1	GD05104140	100KΩ
RJ08			1	1	GD05104140	100KΩ
						PJ00-MISCELLANEOUS
JJ03	1	1	1	1	YT02040150	Terminal, Tape 1
JJ04	1	1	1	1	YT02040150	Terminal, Tape 2
JJ05			1	1	YJ11000170	Jack, Din
JJ06			1	1	YJ11000170	Jack, Din
						PS00-HEAD PHONE CIRCUIT BOARD
PS00	1	1	1	1	YK21392530	P.W. Board, Head Phone
	1	1	1	1	ZZ21392530	P.W. Board Assembly
RS01	1	1	1	1	GA05331010	Resistor 330Ω ±5% 1W
RS02	1	1	1	1	GA05331010	Resistor 330Ω ±5% 1W
JS01	1	1	1	1	YJ01001340	Jack, Head Phone
SS01	1	1	1	1	SP02020480	Push Switch
						PY00-LED POWER LAMP CIRCUIT BOARD
PY00	1	1	1	1	YK21392540	P.W. Board, Led Power Lamp
	1	1	1	1	ZZ21392540	P.W. Board Assembly
QY01	1	1	1	1	HI10009020	L.E.D. LN26RP

REF. DESIG.	Q'TY				PART NO.	DESCRIPTION
	U	C	N	A		
PX00	1	1	1	1	YK21392520	PX00-LED METER CIRCUIT BOARD P.W. Board, Led Meter
	1	1	1	1	ZZ21392520	P.W. Board Assembly
						PX00-RESISTORS (All Resistors are ±5% & ¼W)
RX01	1	1	1	1	GD05152140	1.5KΩ
RX02	1	1	1	1	GD05152140	1.5KΩ
RX03	1	1	1	1	GD05152140	1.5KΩ
RX04	1	1	1	1	GD05152140	1.5KΩ
RX05	1	1	1	1	GD05152140	1.5KΩ
RX06	1	1	1	1	GD05152140	1.5KΩ
RX07	1	1	1	1	GD05152140	1.5KΩ
RX08	1	1	1	1	GD05152140	1.5KΩ
RX09	1	1	1	1	GD05152140	1.5KΩ
RX10	1	1	1	1	GD05152140	1.5KΩ
RX11	1	1	1	1	GD05152140	1.5KΩ
RX12	1	1	1	1	GD05152140	1.5KΩ
RX13	1	1	1	1	GD05152140	1.5KΩ
RX14	1	1	1	1	GD05152140	1.5KΩ
RX15	1	1	1	1	GD05152140	1.5KΩ
RX16	1	1	1	1	GD05152140	1.5KΩ
RX17	1	1	1	1	GD05152140	1.5KΩ
RX18	1	1	1	1	GD05152140	1.5KΩ
RX19	1	1	1	1	GD05152140	1.5KΩ
RX20	1	1	1	1	GD05152140	1.5KΩ
RX21	1	1	1	1	GD05152140	1.5KΩ
RX22	1	1	1	1	GD05152140	1.5KΩ
RX23	1	1	1	1	GD05152140	1.5KΩ
RX24	1	1	1	1	GD05152140	1.5KΩ
RX25	1	1	1	1	GD05153140	15KΩ
RX26	1	1	1	1	GD05392140	3.9KΩ
						PX00-SEMICONDUCTORS
QX01	1	1	1	1	HI11202320	L.E.D. GL-112R4
QX02	1	1	1	1	HI11202320	L.E.D. GL-112R4
QX03	1	1	1	1	HC10002320	IC IR2148A
QX04	1	1	1	1	HC10002320	IC IR2148A

(W01-99)	Assembly and Wiring
(T01-99)	Adjustment
(X01-00)	Correction

13. TECHNICAL SPECIFICATIONS (PM500 and PM700)**MODEL PM500****AUDIO SECTION**

POWER OUTPUT, DIN, 4 OHM, PER CHANNEL	83W
POWER OUTPUT, FTC AMERICAN STANDARDS, 4 OHM, PER CHANNEL	63W
TOTAL HARMONIC DISTORTION AT RATED POWER OUTPUT	0.06%
I.M. DISTORTION AT RATED POWER OUTPUT (250 Hz AND 8 kHz MIXED, AMPLITUDE RATIO 4:1)	0.06%
POWER OUTPUT, DIN, 8 OHM, PER CHANNEL	58W
POWER OUTPUT, FTC AMERICAN STANDARDS, 8 OHM, PER CHANNEL	50W
TOTAL HARMONIC DISTORTION AT RATED POWER OUTPUT	0.03%
I.M. DISTORTION AT RATED POWER OUTPUT (250 Hz AND 8 kHz MIXED, AMPLITUDE RATIO 4:1)	0.03%
POWER BANDWIDTH	10 Hz ~ 70 kHz
DAMPING FACTOR 8 OHM	110
Frequency Response	
Phono (RIAA)	±0.25 dB
Aux (±1 dB)	10 Hz ~ 60 kHz
Signal-to-Noise Ratio (IHF-A Network)	
Phono (MM)	88 dB
Aux	93 dB
Input Terminals	
Phono: Input Impedance	47 k ohms
Input Capacitance	220 pF
Input Sensitivity	1.8 mV
Overload Margin	38 dB
Aux: Input Impedance	25 k ohms
Input Sensitivity	21 mV
Phono Equivalent Input Noise	0.4 µV
Phono Dynamic Range (Ratio of input overload to equivalent input noise)	108 dB
Channel Balance (0 to -40 dB/40 Hz ~ 16 kHz)	
Phono	2.0 dB
Aux	1.6 dB
Interchannel Crosstalk	
Phono, 1 kHz	50 dB
Aux, 1 kHz	65 dB
Tape, 1 kHz	65 dB
Intersource Crosstalk (Worst Point), 1 kHz	58 dB
Output Voltage, 1 kHz	
Tape Out	415 mV
Output Impedance, 1 kHz	
Tape Out	220 ohms

GENERAL

Power Requirements	220 V AC, 50 Hz
(E and N versions are featuring an external voltage selector for use on 110V. Other versions can be converted by a qualified technician to operate on 240V.)	
Power Consumption at Rated Output, both Channels Driven	230W ± 20W
Idling Power	45W ± 5W
Semiconductor Complement	
Transistors	54
Diodes	66
Integrated Circuits	9
Dimensions	
Panel Width	416 mm (16-3/8 inches)
Panel Height	146 mm (5-3/4 inches)
Depth	330 mm (13 inches)
Weight	
Unit Alone	9.5 kg (20.9 lbs)
Packed for Shipment	11 kg (24.2 lbs)

MODEL PM700

AUDIO SECTION

POWER OUTPUT, DIN, 4 OHM, PER CHANNEL	100W
POWER OUTPUT, FTC AMERICAN STANDARDS, 4 OHM, PER CHANNEL	88W
TOTAL HARMONIC DISTORTION AT RATED POWER OUTPUT	0.06%
I.M. DISTORTION AT RATED POWER OUTPUT (250 Hz AND 8 kHz MIXED, AMPLITUDE RATIO 4:1)	0.06%
POWER OUTPUT, DIN, 8 OHM, PER CHANNEL	80W
POWER OUTPUT, FTC AMERICAN STANDARDS, 8 OHM, PER CHANNEL	70W
TOTAL HARMONIC DISTORTION AT RATED POWER OUTPUT	0.03%
I.M. DISTORTION AT RATED POWER OUTPUT (250 Hz AND 8 kHz MIXED, AMPLITUDE RATIO 4:1)	0.03%
POWER BANDWIDTH	10 Hz ~ 70 kHz
DAMPING FACTOR 8 OHM	110

Frequency Response

Phono (RIAA)	±0.25 dB
Aux (±1 dB)	10 Hz ~ 60 kHz
Signal-to-Noise Ratio (IHF-A Network)	
Phono (MC)	78 dB
(MM)	88 dB
Aux	93 dB

Input Terminals

Phono: Input Impedance	47 k ohms
Input Capacitance	220 pF
Input Sensitivity	0.33 mV
Overload Margin	38 dB
Aux: Input Impedance	25 k ohms
Input Sensitivity	18 mV
Phono Equivalent Input Noise	0.38 µV
Phono Dynamic Range (Ratio of input overload to equivalent input noise)	112 dB

Channel Balance (0 to -40 dB/40 Hz ~ 16 kHz)

Phono	2.0 dB
Aux	1.6 dB

Interchannel Crosstalk

Phono, 1 kHz	50 dB
Aux, 1 kHz	65 dB
Tape, 1 kHz	65 dB
Intersource Crosstalk (Worst Point), 1 kHz	58 dB

Output Voltage, 1 kHz

Tape Out	415 mV
Output Impedance, 1 kHz	
Tape Out	220 ohms

GENERAL

Power Requirements	220 V AC, 50 Hz (E and N versions are featuring an external voltage selector for use on 110V. Other versions can be converted by a qualified technician to operate on 240V.)
Power Consumption at Rated Output, both Channels Driven	300W ± 20W
Idling Power	50W ± 5W
Semiconductor Complement	
Transistors	54
Diodes	66
Integrated Circuits	9
Dimensions	
Panel Width	416 mm (16-3/8 inches)
Panel Height	146 mm (5-3/4 inches)
Depth	330 mm (13 inches)
Weight	
Unit Alone	10 kg (22 lbs)
Packed for Shipment	11.5 kg (25.3 lbs)

Model PM 500

09, 0710, Q715
6, 0729, Q730
3140Q1E
IC14001E)

0711, Q712
HT109702AO
25A970(QRvBL)

0713, Q714
HT322402AO
25C224(QRvBL)

0717, Q718
HT322292AO
25C222(QRvY)

0719, Q720
HT109492AO
25A949(QRvY)

0721, Q722
HT322913AO
25C2291(QRvR)

0723, Q724
HT11113AD
25A1113

0725, Q726
HT32262AO
25C226(QRvR)

0727, Q728
HT11412AO
25A114(QRvR)

0733~0738
0745~0748
0755, 0756
HD2000210
152473

0739~0742
0753, 0754
HD2000210
152471

0743, 0744
HV0001020
MV-11Y

0749~0752
HD20015030
DS135 (D)

Q801
HT323442AO
25C2344

Q802
HT10122AO
25A1011

Q803, Q805, Q808
HT34001E
25C1400

Q804, Q806, Q807
HT107501E
25A750

Q809, Q810
HD20015030
DS135 (D)

Q811, Q812
HD30008010
HZ6L (B)

Q401, Q402
HC10034010
HA1457W

QE01, QE02
HC10034010
HA1457W

QF01, QF02
HC10034010
HA1457W

QF03~QF12
HT314001E
25C1400

QX01~QX04
HD2001290
S3V20

QX05, QX06
HD20015030
DS135 (D)

QX07
HC10048050
TA2317P

QX08, QX09
HD2001290
S3V20

QX10, QX11
HD2001290
S3V20

QX12, QX13
HT107501E
25A750

QX14
HD30047090
WZ192

QX15
HT106672E
25D667

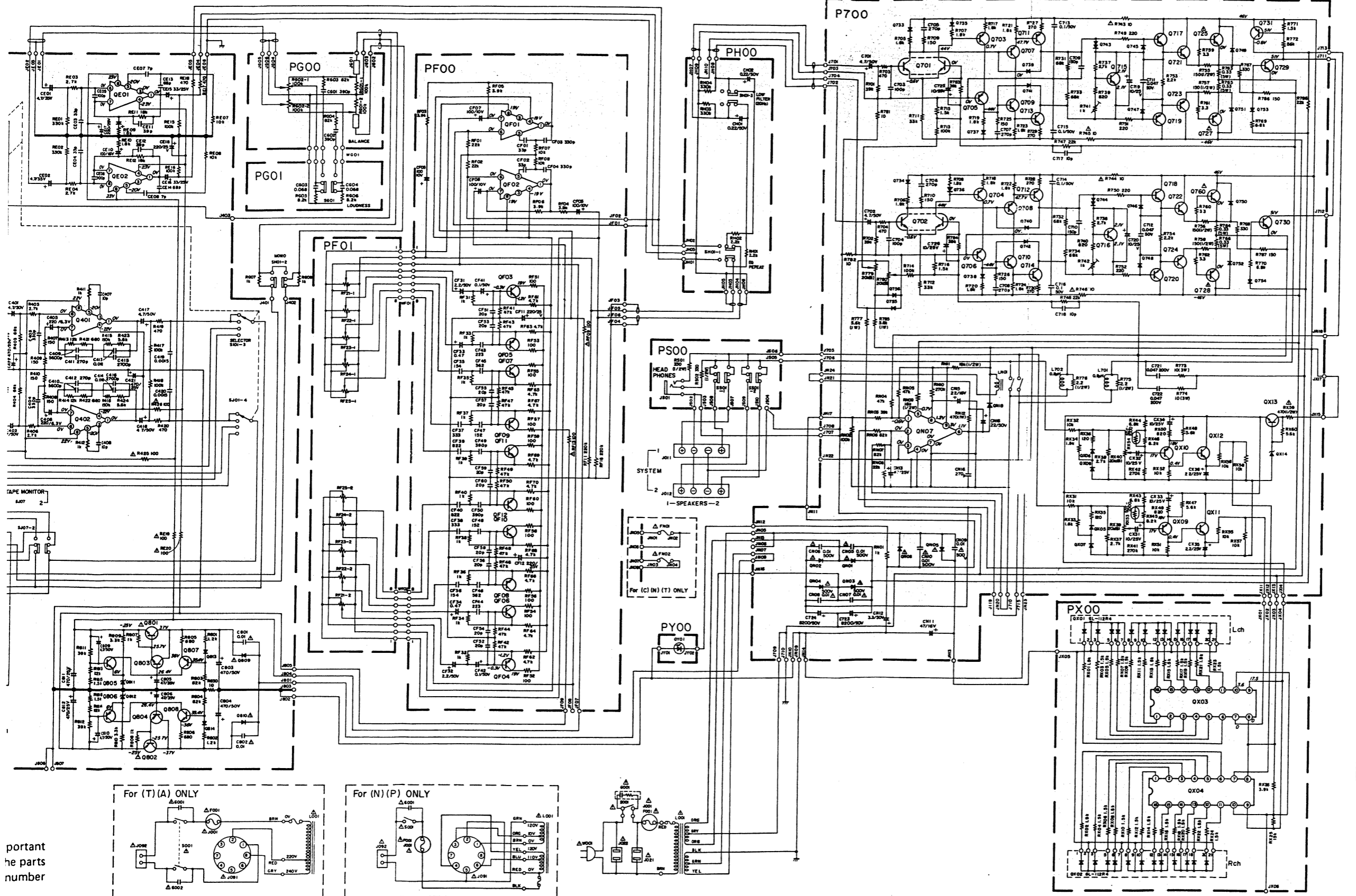

- MARKING SIDE
- Q721~Q724
- Q701, Q702
- Q725~Q728
- BOTTOM VIEW
- QX13
- BOTTOM VIEW
- Q401, Q402
QE01, QE02
QF01, QF02
- BOTTOM VIEW
- Q703~Q720
Q729~Q731
Q801~Q807
- TOP VIEW
- QX01, QX02
- QX03, QX04
QX05~QX12
- QX07

portant
he parts
number

Q701, Q702 HT322592G0 25C2259(F or G)
 Q703 ~ Q708, Q731 HT107501E0 25A7501(E)
 Q709, Q710, Q715 HT322402A0 25C2240(A or B)
 Q716, Q729, Q730 HT314001E0 25C1400(E)
 Q711, Q712 HT109702A0 25A970(G or B/L)
 Q713, Q714 HT322402A0 25C2240(A or B)
 Q717, Q718 HT322292A0 25C2229(A or Y)
 Q719, Q720 HT109492A0 25A949(Q or Y)
 Q721, Q722 HT3225913A0 25C2591(K or R)
 Q723, Q724 HT111113A0 25A1111(H or R)
 Q725, Q726 HT3225982A0 25C2598(A or R)
 Q727, Q728 HT111082A0 25A1108(A or R)
 Q733 ~ Q738 Q745 ~ Q758 Q753, Q754 HT20008210 1S2473
 Q739 ~ Q742 HT20008210 1S2471
 Q743, Q744 HV00010120 MV-11Y
 Q749 ~ Q752 HD20015030 D5135 (D)
 Q801 HT323442A0 25C2344
 Q802 HT11012A0 25A1011
 Q803, Q805, Q808 HT34001E 25C1400
 Q804, Q806, Q807 HT107501E0 25A750
 Q809, Q810 HD20015030 D5135 (D)
 Q811, Q812 HD30008010 HZ6L (B)
 Q401, Q402 HC10035010 HAI2017
 QE01, QE02 HC10034010 HAI457W

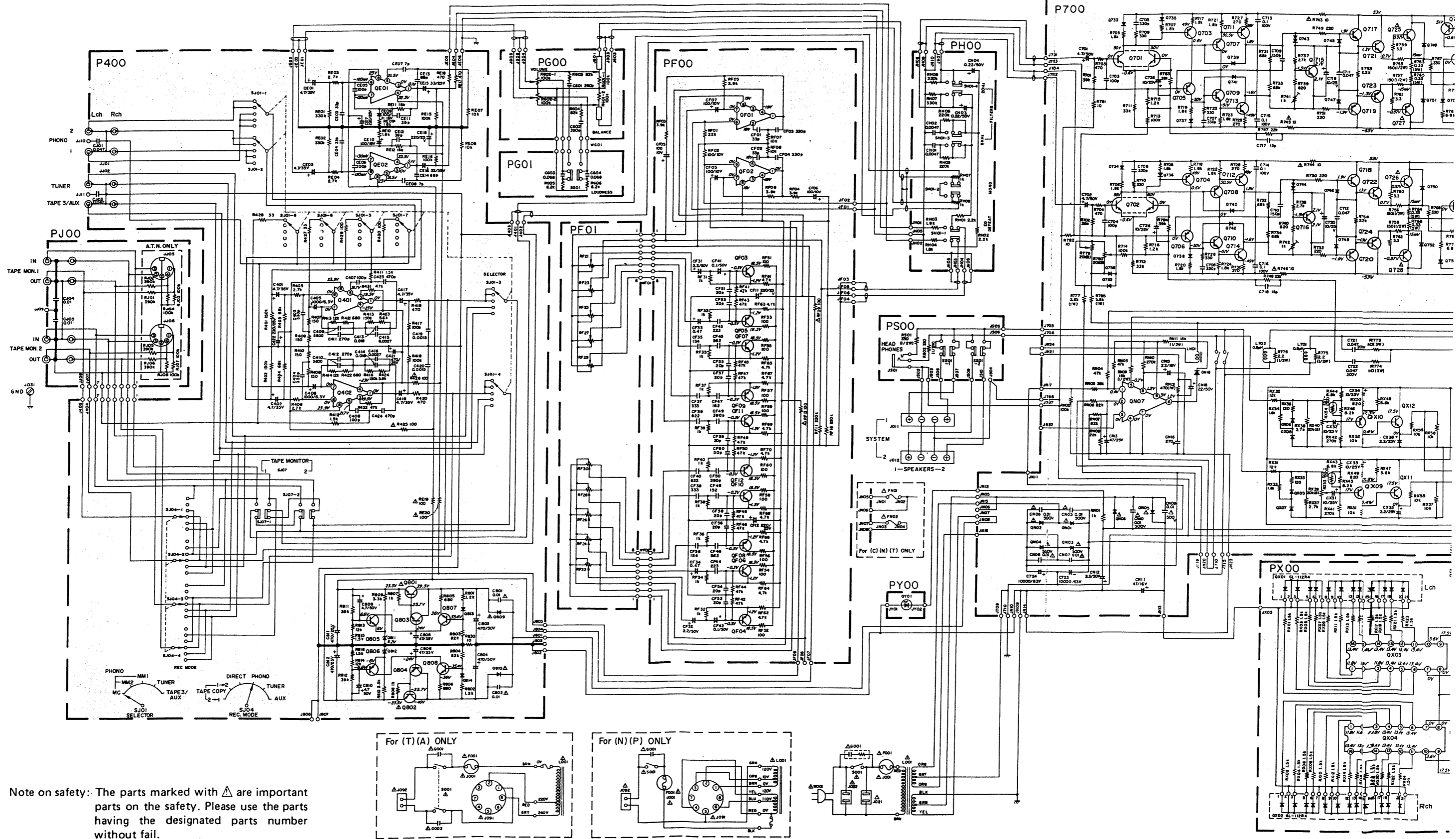

Model PM 700

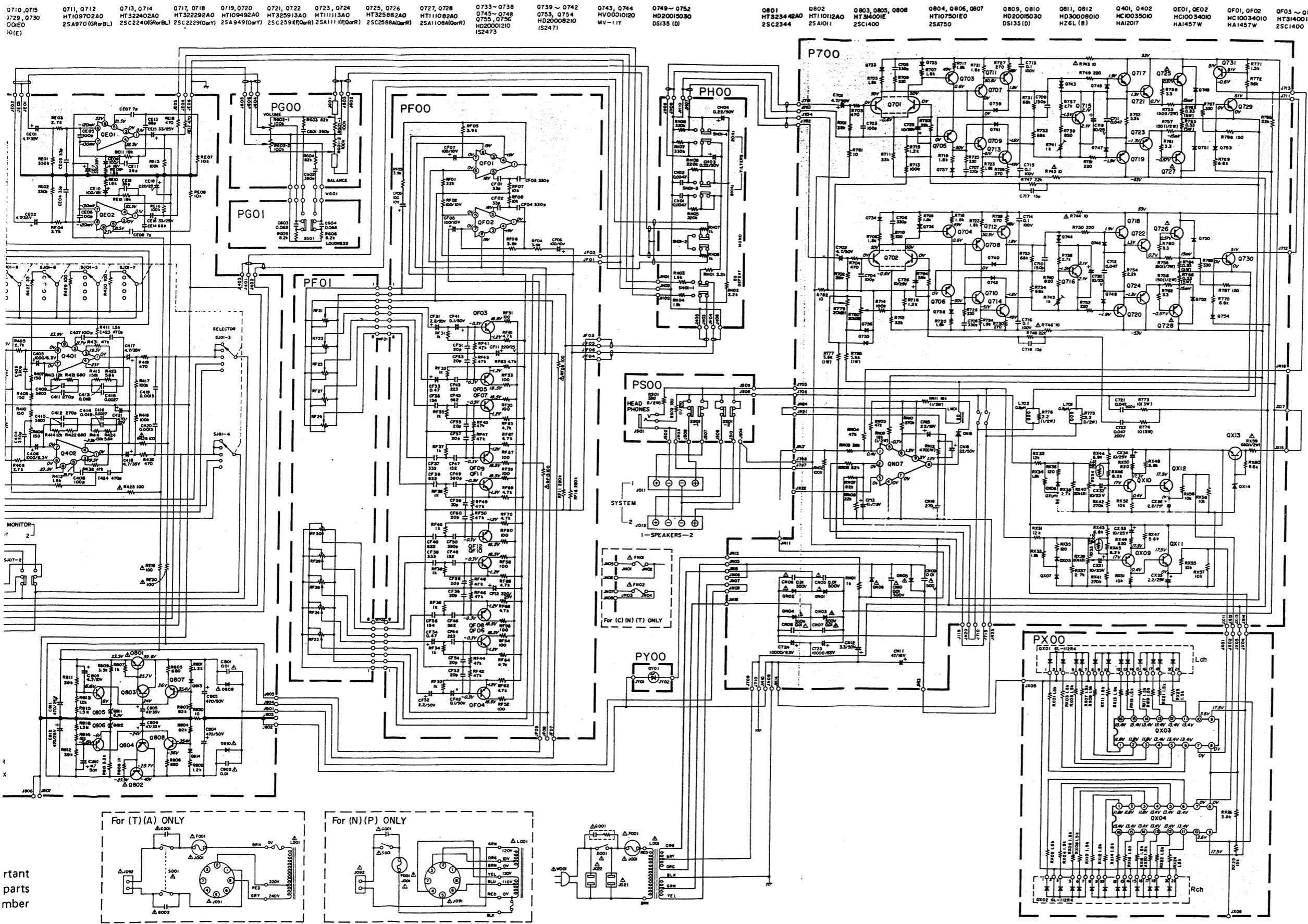

Q710, Q715
Q729, Q730
Q710E

Q711, Q712
HT109702AO
25A970 (GRwL)

Q713, Q714
HT322402AO
25C2240 (GRwBL)

Q717, Q718
HT32292AO
25C2292 (GRw)

Q719, Q720
HT109492AO
25A949 (GRwY)

Q721, Q722
HT325913AO
25C25913 (GRwR)

Q723, Q724
HT11113AO
25A1111 (HPGRwR)

Q725, Q726
HT325882AO
25C25882 (GRwR)

Q727, Q728
HT1108A2AO
25A1108A (GRwR)

Q733~Q738
Q745~Q748
Q755, Q756
HD200012IO
IS2473

Q739~Q742
Q753, Q754
HD200082IO
IS2471

Q743, Q744
HV0001012O
MV-11Y

Q749~Q752
HD2001503O
DS135 (D)

Q801

Q802

Q803, Q805, Q808

Q804, Q806, Q807

Q809, Q810

Q811, Q812

Q401, Q402

Q601, Q602

QF01, QF02

QF03~QF12

QX01~QX04

QX05, QX06

QX03, QX04

QX05~QX08

QX09, QX10

QX11~QX12

QX13

QX14

QX01, QX02

QX03, QX04

QX05~QX08

QX09, QX10

QX11~QX12

QX13

QX14

QX01, QX02

QX03, QX04

QX05~QX08

QX09, QX10

QX11~QX12

QX13

QX14

QX01, QX02

QX03, QX04

QX05~QX08

QX09, QX10

QX11~QX12

QX13

QX14

QX01, QX02

QX03, QX04

QX05~QX08

QX09, QX10

QX11~QX12

QX13

QX14

QX01, QX02

QX03, QX04

QX05~QX08

QX09, QX10

QX11~QX12

QX13

QX14

QX01, QX02

QX03, QX04

QX05~QX08

QX09, QX10

QX11~QX12

QX13

QX14

QX01, QX02

QX03, QX04

QX05~QX08

QX09, QX10

QX11~QX12

QX13

QX14

QX01, QX02

QX03, QX04

QX05~QX08

QX09, QX10

QX11~QX12

QX13

QX14

QX01, QX02

QX03, QX04

QX05~QX08

QX09, QX10

QX11~QX12

QX13

QX14

QX01, QX02

QX03, QX04

QX05~QX08

QX09, QX10

QX11~QX12

QX13

QX14

QX01, QX02

QX03, QX04

QX05~QX08

QX09, QX10

QX11~QX12

QX13

QX14

QX01, QX02

QX03, QX04

QX05~QX08

QX09, QX10

QX11~QX12

QX13

QX14

QX01, QX02

QX03, QX04

QX05~QX08

QX09, QX10

QX11~QX12

QX13

QX14

QX01, QX02

QX03, QX04

QX05~QX08

QX09, QX10

QX11~QX12

QX13

QX14

QX01, QX02

QX03, QX04

QX05~QX08

QX09, QX10

QX11~QX12

QX13

QX14

QX01, QX02

QX03, QX04

QX05~QX08

QX09, QX10

QX11~QX12

QX13

QX14

QX01, QX02

QX03, QX04

QX05~QX08

QX09, QX10

QX11~QX12

QX13

QX14

QX01, QX02

QX03, QX04

QX05~QX08

QX09, QX10

QX11~QX12

QX13

QX14

QX01, QX02

QX03, QX04

QX05~QX08

QX09, QX10

QX11~QX12

QX13

QX14

QX01, QX02

QX03, QX04

QX05~QX08

QX09, QX10

QX11~QX12

QX13

QX14

QX01, QX02

QX03, QX04

QX05~QX08

QX09, QX10

QX11~QX12

QX13

QX14

QX01, QX02

QX03, QX04

QX05~QX08

QX09, QX10

QX11~QX12

QX13

QX14

QX01, QX02

QX03, QX04

QX05~QX08

QX09, QX10

QX11~QX12

QX13

QX14

QX01, QX02

QX03, QX04

QX05~QX08

QX09, QX10

QX11~QX12

QX13

QX14

QX01, QX02

QX03, QX04

QX05~QX08

QX09, QX10

QX11~QX12

QX13

QX14

- Q801 HT323442AO 25C2344
- Q802 HT11012AO 25A1011
- Q803, Q805, Q808 HT3400IE 25C1400
- Q804, Q806, Q807 HT107501EO 25A750
- Q809, Q810 HD200503O DS135 (D)
- Q811, Q812 HD300801O HZ6L (B)
- Q401, Q402 HC100350O HAI2017
- Q601, Q602 HC1003401O HAI457W
- QF01, QF02 HC1003401O HAI457W
- QF03~QF12 HT314001EO 25C1400
- QX01~QX04 HD200129O 53V20
- QX05, QX06 HD2001503O DS135 (D)
- QX07 HC1004205O TA2317P
- QX08, QX02 H11120232O GL-112R4
- QX03, QX04 HC1000232O IR2418A
- QX05~QX08 HD2000210 IS2473
- QX09, QX10 HT107501EO 25A750
- QX11~QX12 HT314001EO 25C1400
- QX13 HT406672EO 25D667
- QX14 HD3004709O WZ192
- Q721~Q724
- Q701, Q702
- Q725~Q728
- Q401, Q402
Q601, Q602
QX07
- BOTTOM VIEW
Q703~Q720
Q729~Q731
Q801~Q807
- TOP VIEW
QX01, QX02
- QX07

rtant
parts
mber