

Service Manual

74 PM53 / 01B / 02B / 05B
/ 01G / 02G

Integrated stereo amplifier

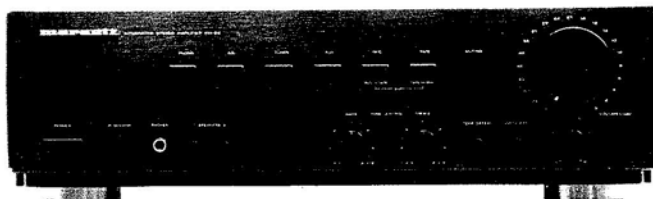

TABLE OF CONTENTS

SECTION	PAGE
1. BLOCK DIAGRAM	2
2. SCHEMATIC DIAGRAM AND PARTS LOCATION (Pattern Side).....	4
3. EXPLODED VIEW AND PARTS LIST	17
4. TEST EQUIPMENT REQUIRED FOR SERVICING	19
5. IDLING CURRENT ADJUSTMENT	19
6. USE OF SERVICE HOLE	19
7. VOLTAGE CONVERSION	20
8. HOW TO CHANGE THE SUPPLY VOLTAGE.....	20
9. MICROPROCESSOR	20
10. ELECTRICAL PARTS LIST	21

marantz®

model PM-53

First issue : 1993
4822 725 51027
PCS 70 786

TECHNICAL SPECIFICATIONS (DIN)

Power output
 RMS 8 Ohms (20 Hz - 20 kHz) 65 / 80 W
 Din 8 Ohms / 4 Ohms 70 / 90 W

IHF dynamic power
 8 Ohms / 4 Ohms 90 / 110 W
 THD at 8 Ohms RMS rated output 0.008 %
 Intermodulation distortion 0.008 %
 Damping factor 100

Magnetic cartridge input
 Input sensitivity impedance 2.5 mV / 47 k ohms
 Accuracy of frequency response to RIAA 0.5 dB
 Signal to noise ratio 93 dB

Tuner / CD / Aux / Tape inputs
 Input sensitivity impedance 150 mV / 33 k ohms
 Signal to noise ratio 103 dB
 Frequency response (-1 dB) 10 - 70 kHz
 Tone characteristic (100 Hz and 10 kHz) ± 6 dB
 Channel separation > 85 dB

General

Power Requirements
 / 01B / 01G version (4 voltages) 110 / 120 / 220 / 240 V AC, 50 / 60 Hz
 / 02B / 02G version 230 V AC 50 Hz
 / 05B version 240 V AC 50 Hz

Dimensions
 Panel width 420 mm
 Panel Height 118 mm
 Depth 300 mm

Weight
 Unit alone 6.3 kg

Specifications subject to change without prior notice.

1. BLOCK DIAGRM

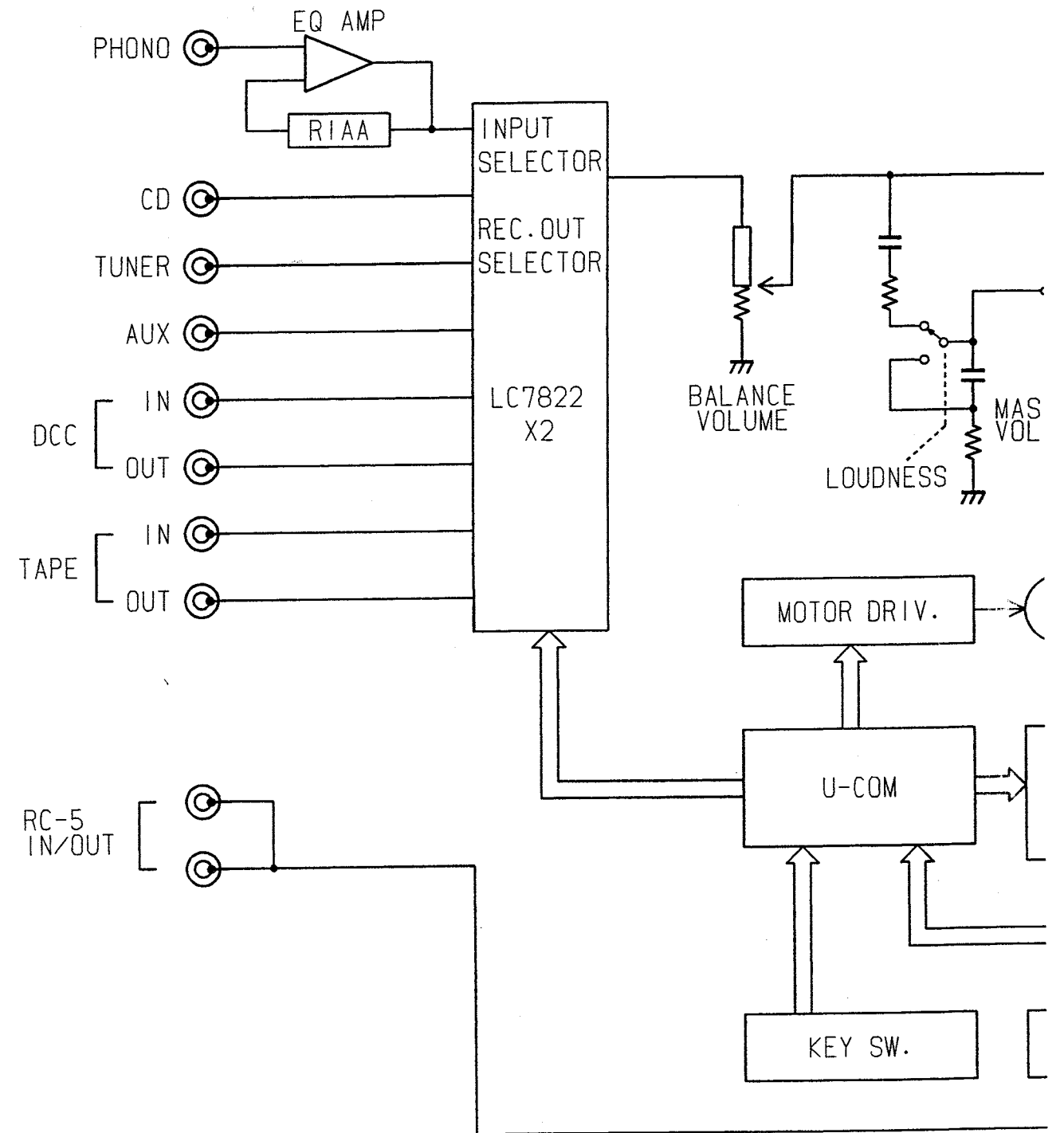

1. BLOCK DIAGRM

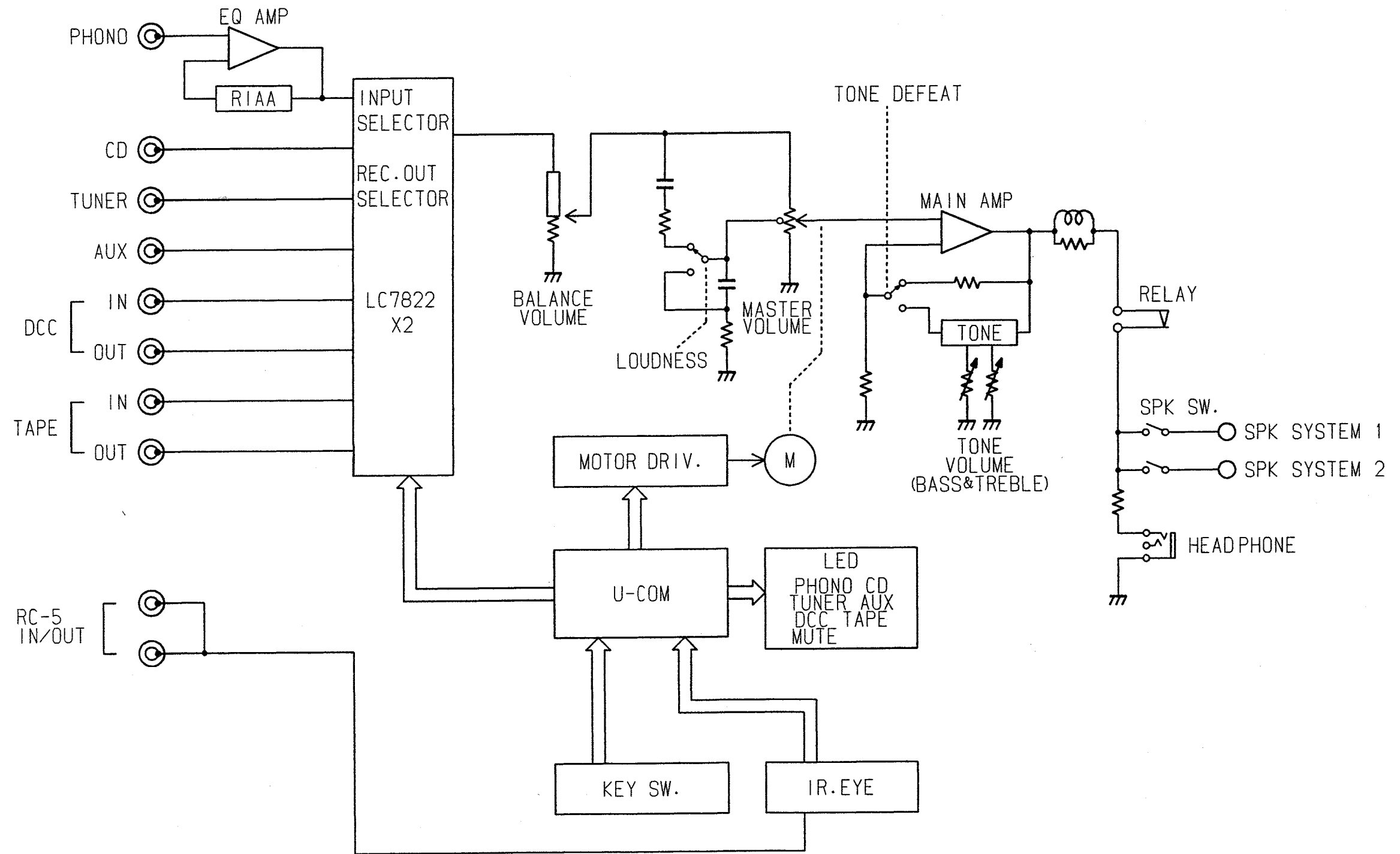

..... 65 / 80 W
 70 / 90 W

 90 / 110 W
 0.008 %
 0.008 %
 100

 mV / 47 k ohms
 0.5 dB
 93 dB

 mV / 33 k ohms
 103 dB
 10 - 70 kHz
 ± 6 dB
 > 85 dB

 / AC, 50 / 60 Hz
 230 V AC 50 Hz
 240 V AC 50 Hz

 420 mm
 118 mm
 300 mm

 6.3 kg

2. SCHEMATIC DIAGRAM AND PARTS LOCATION (Pattern Side)

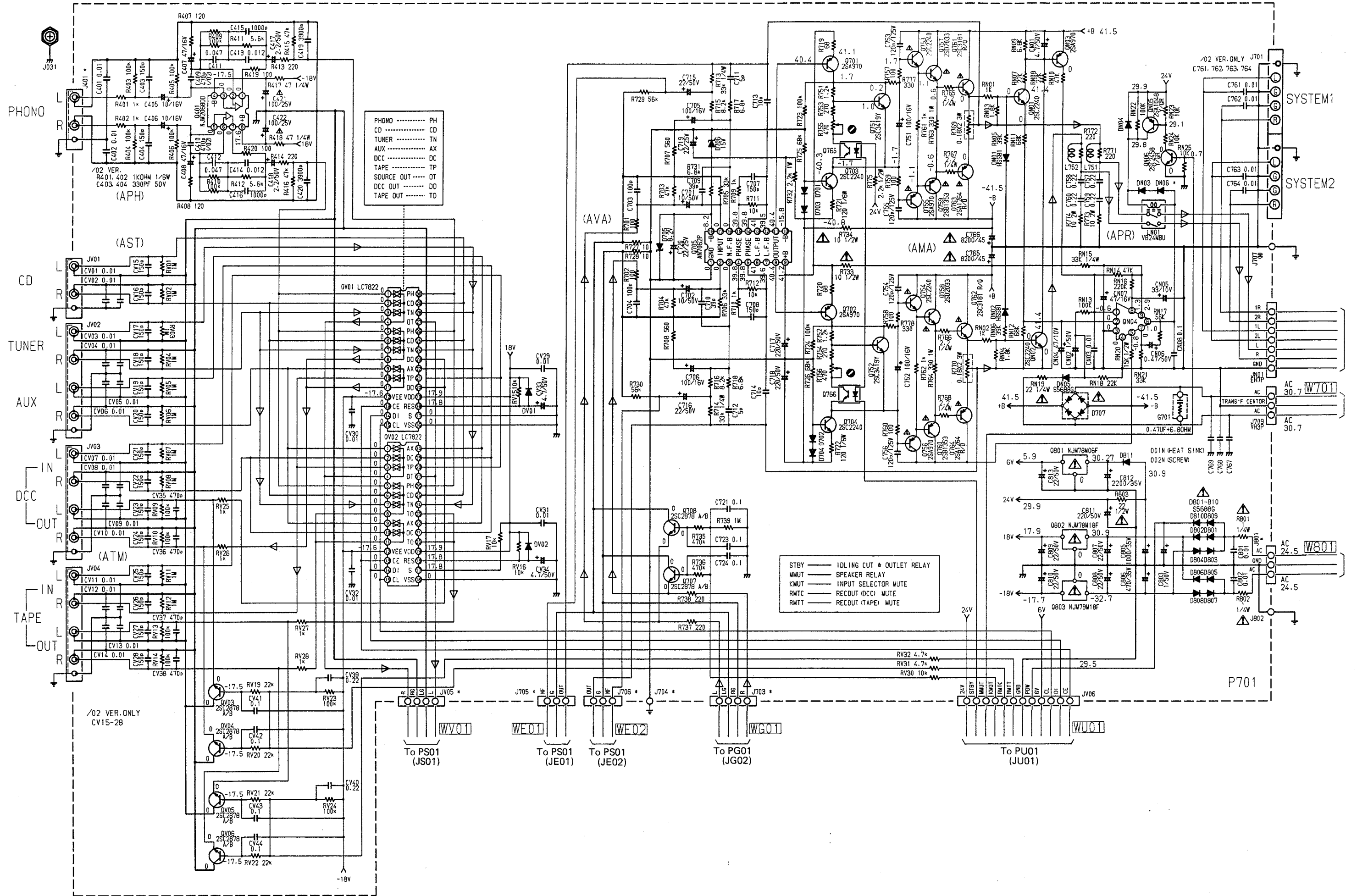

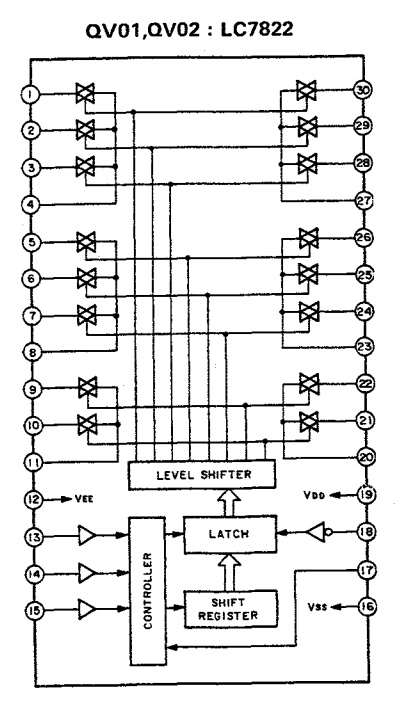
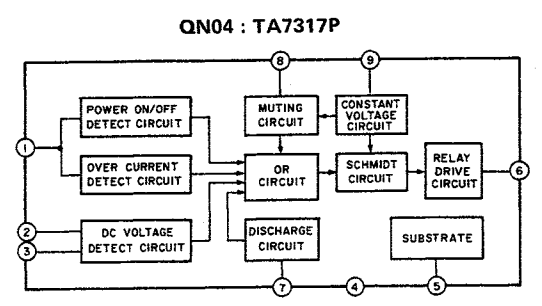
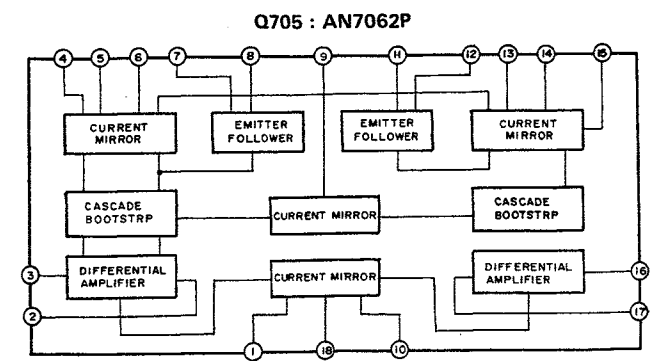
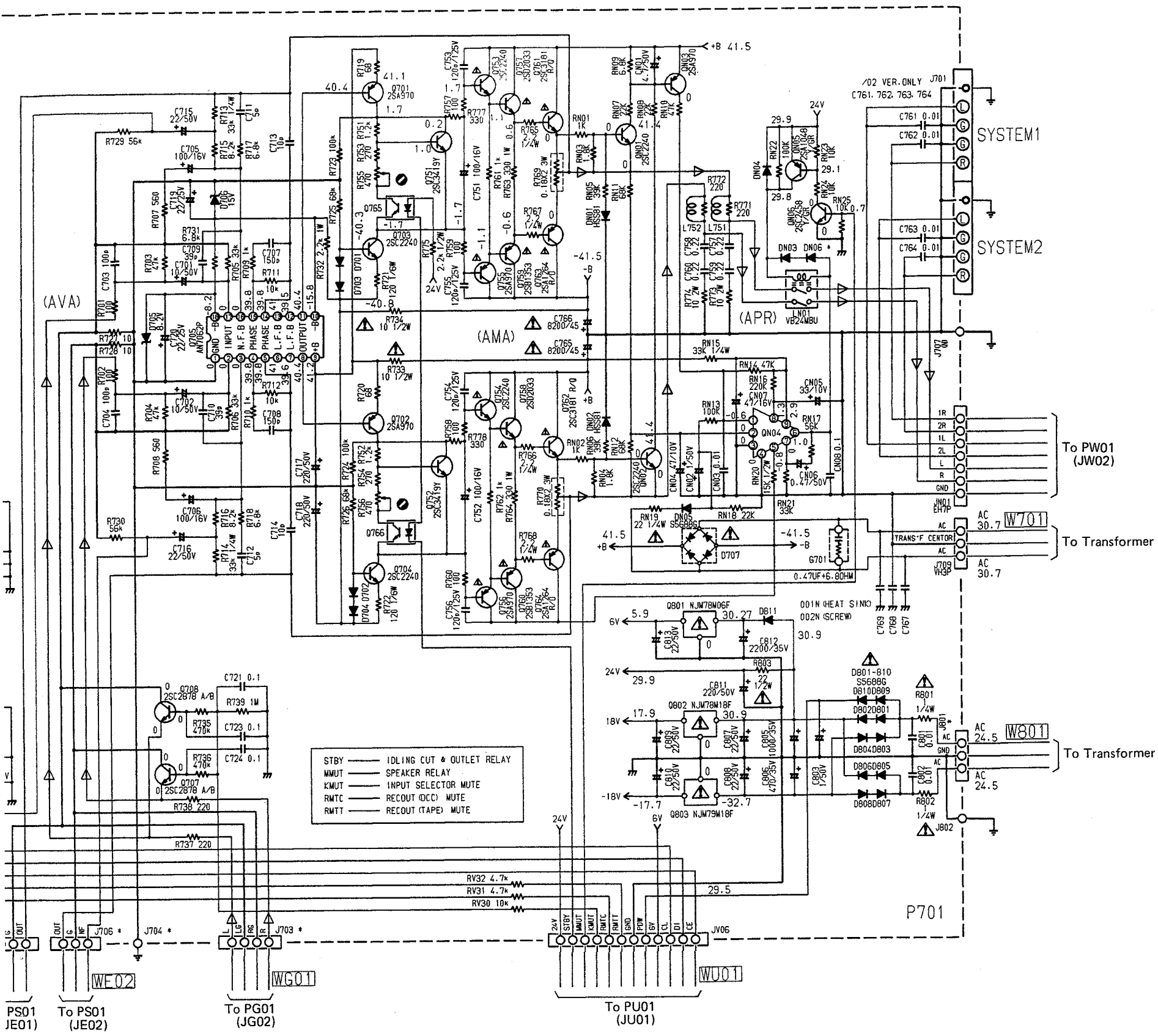

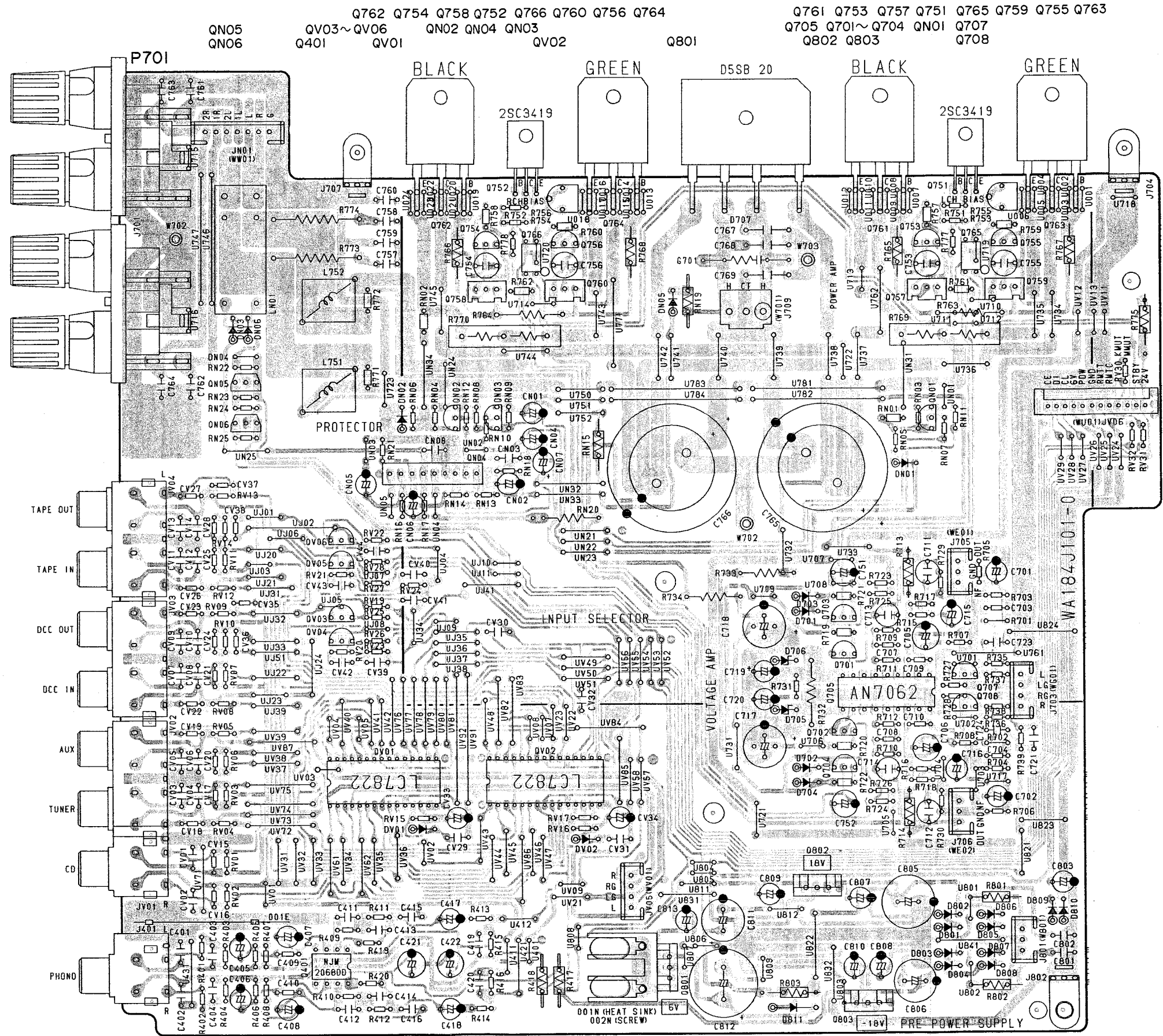

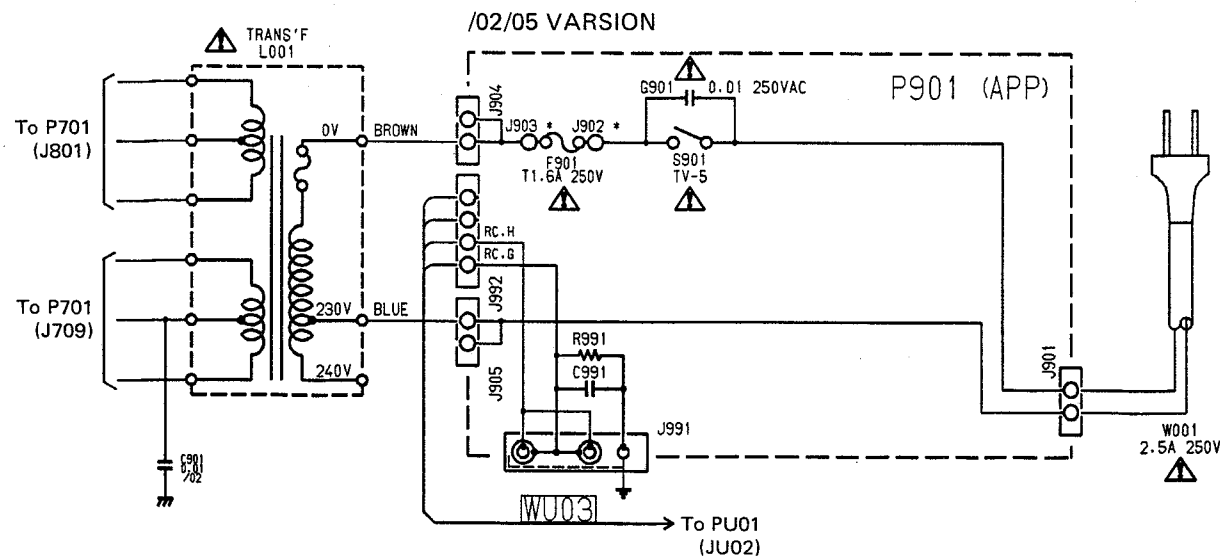
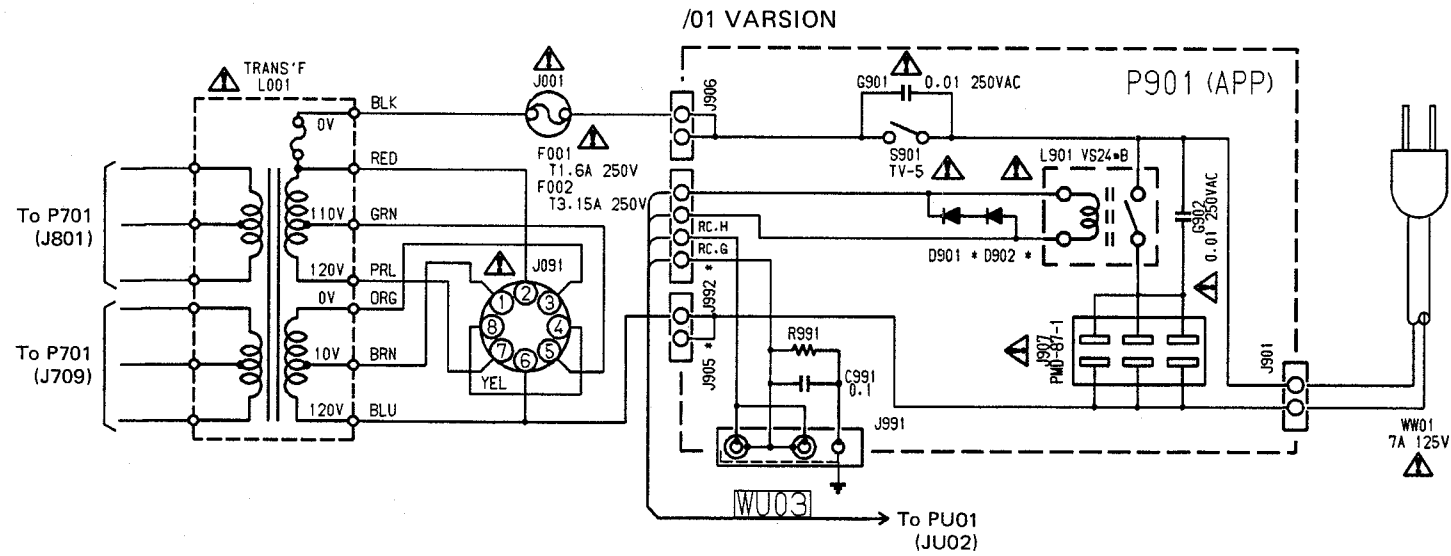
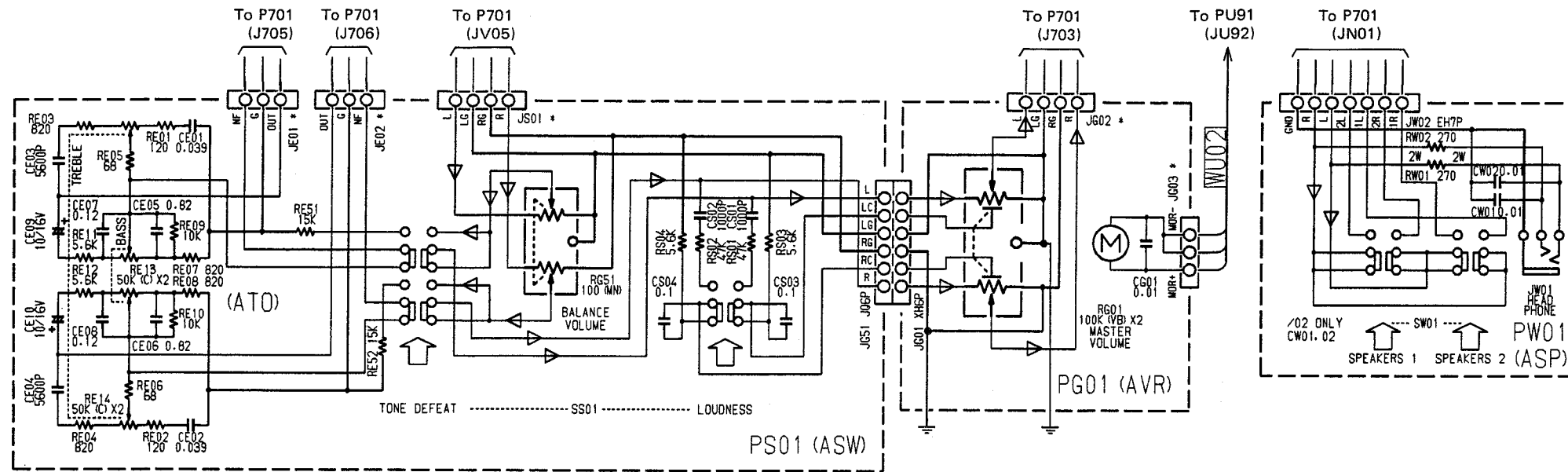

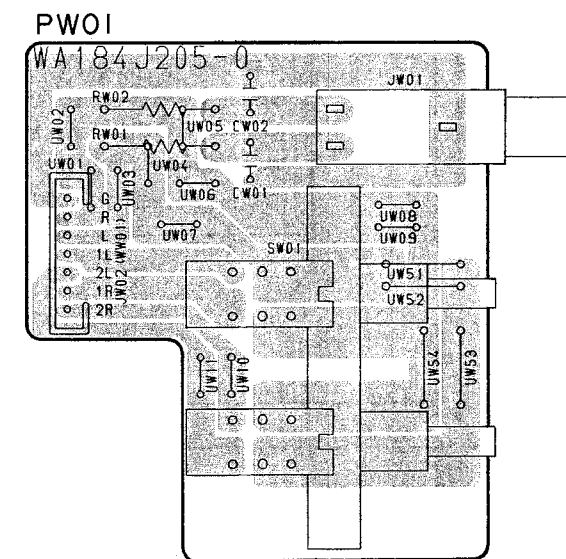
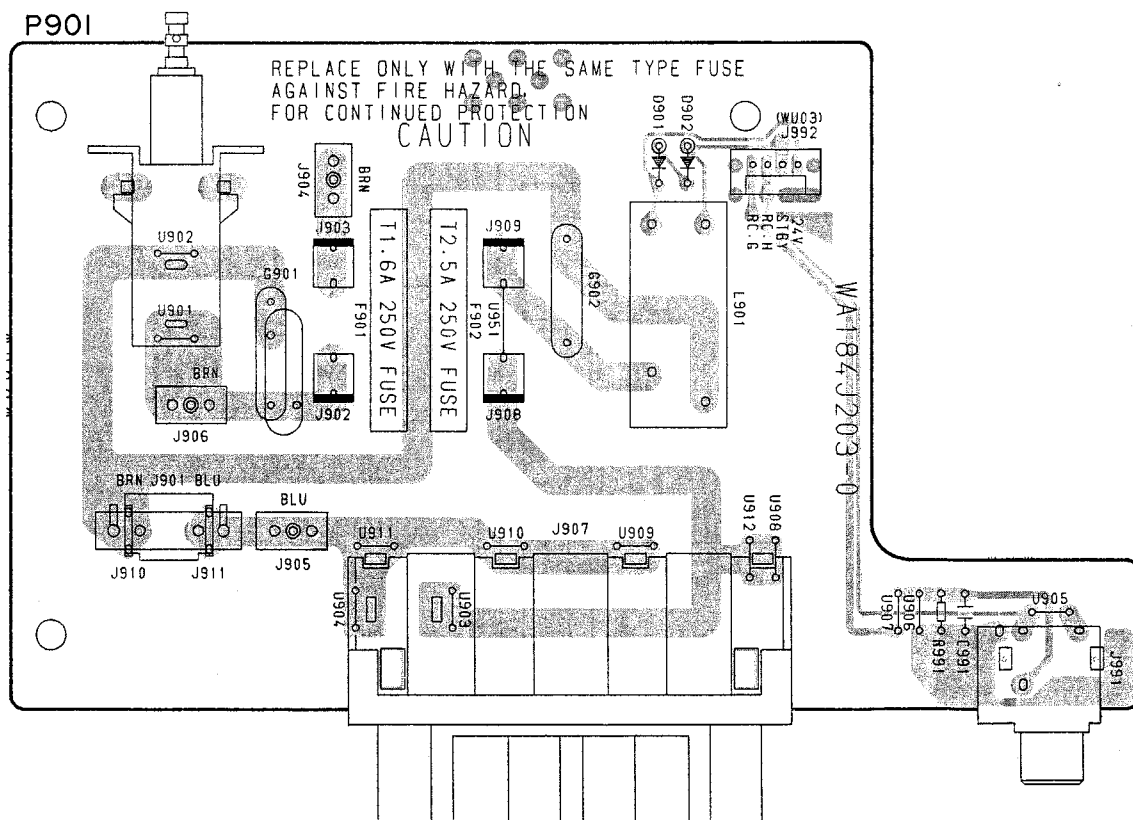
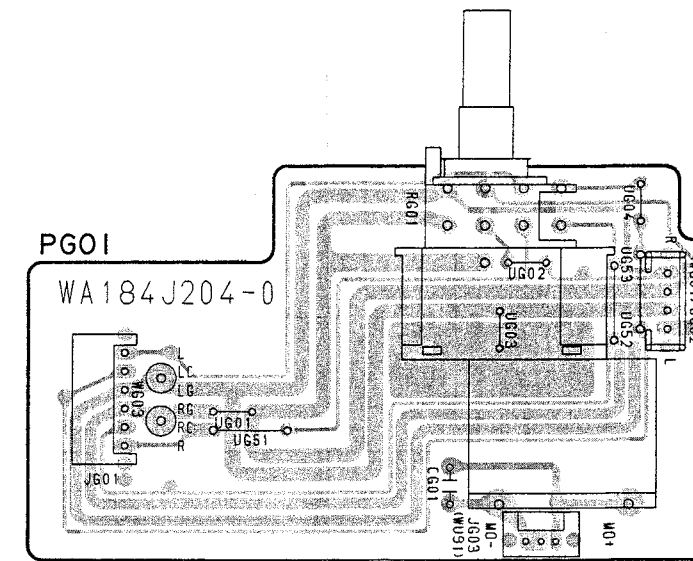
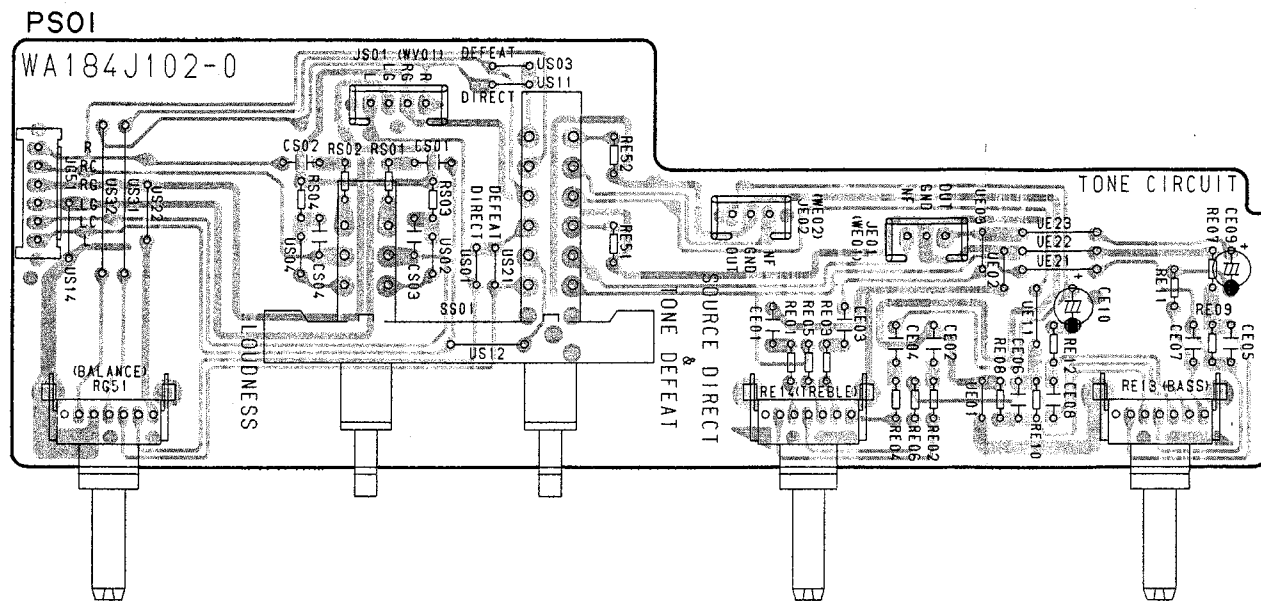

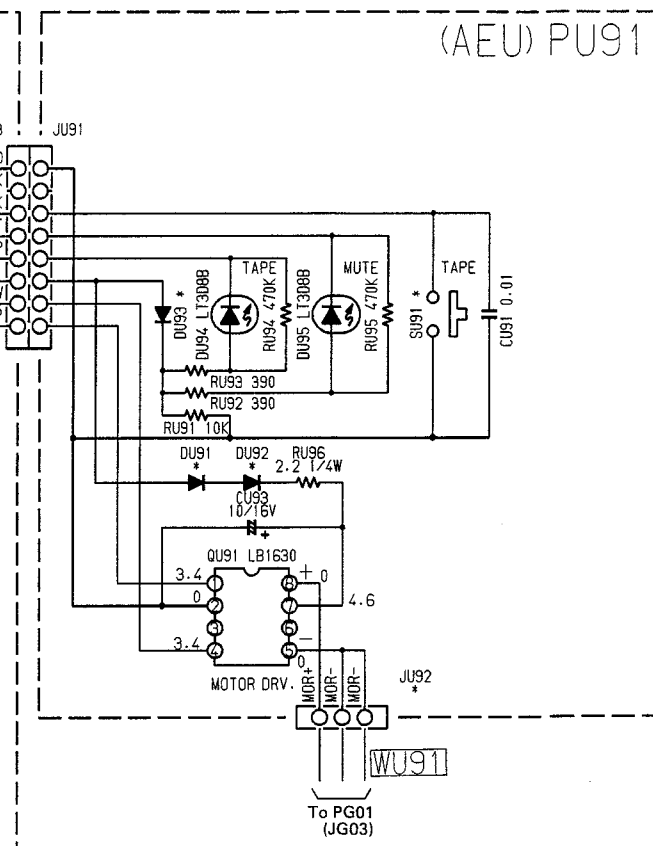
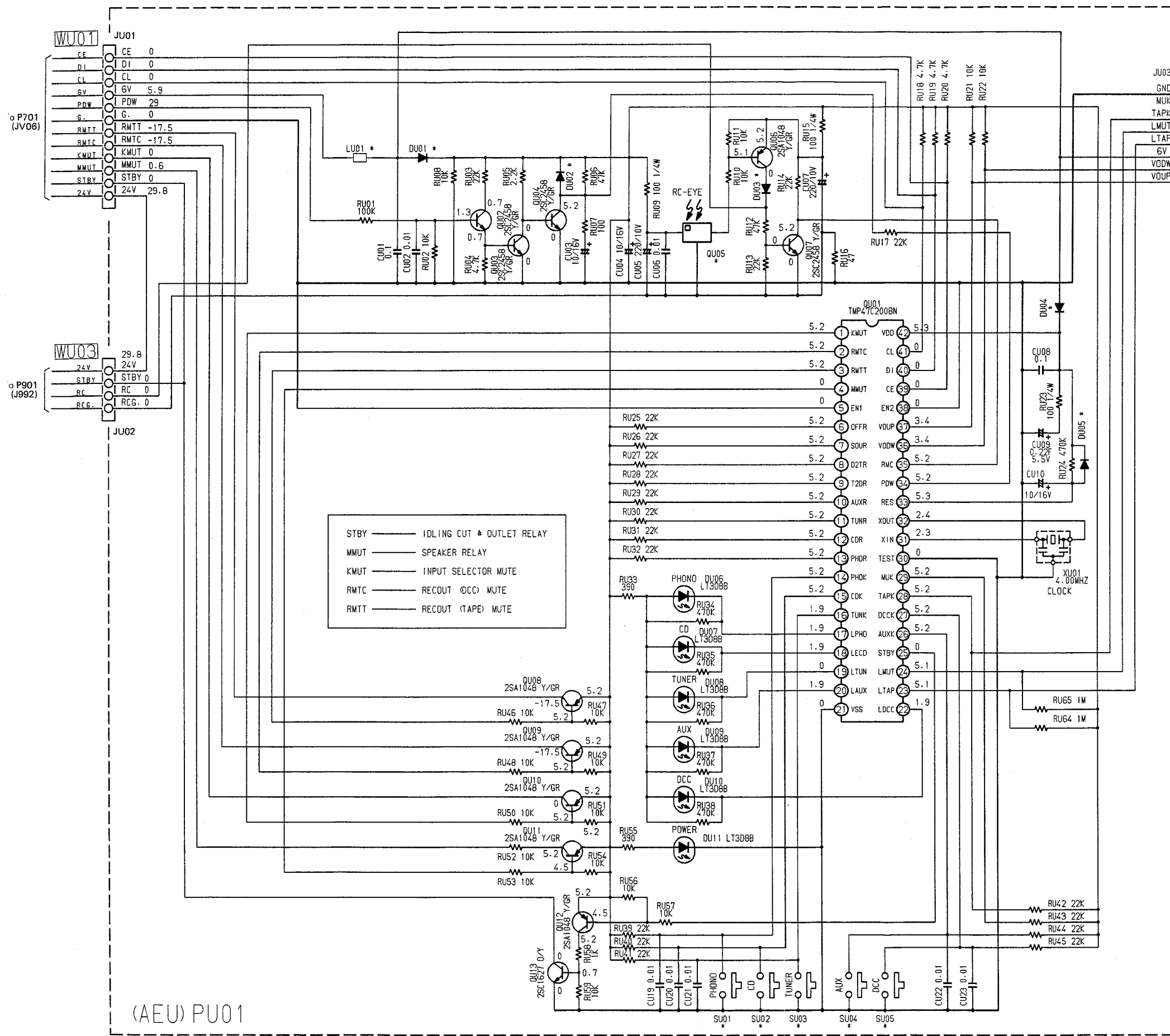

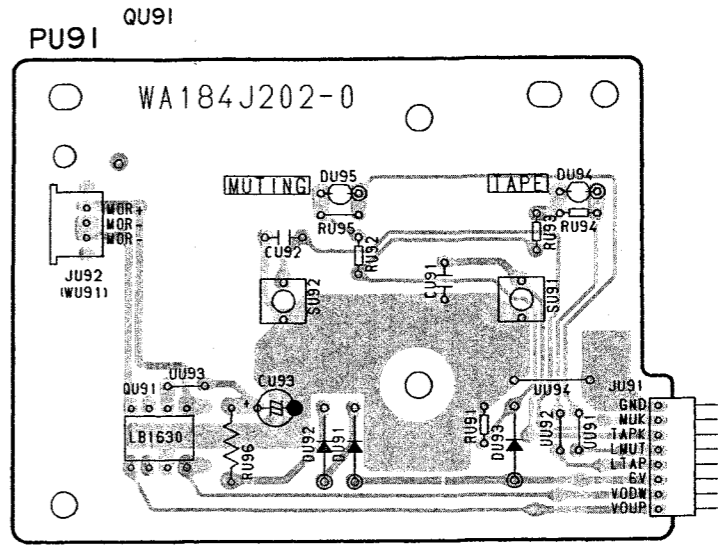
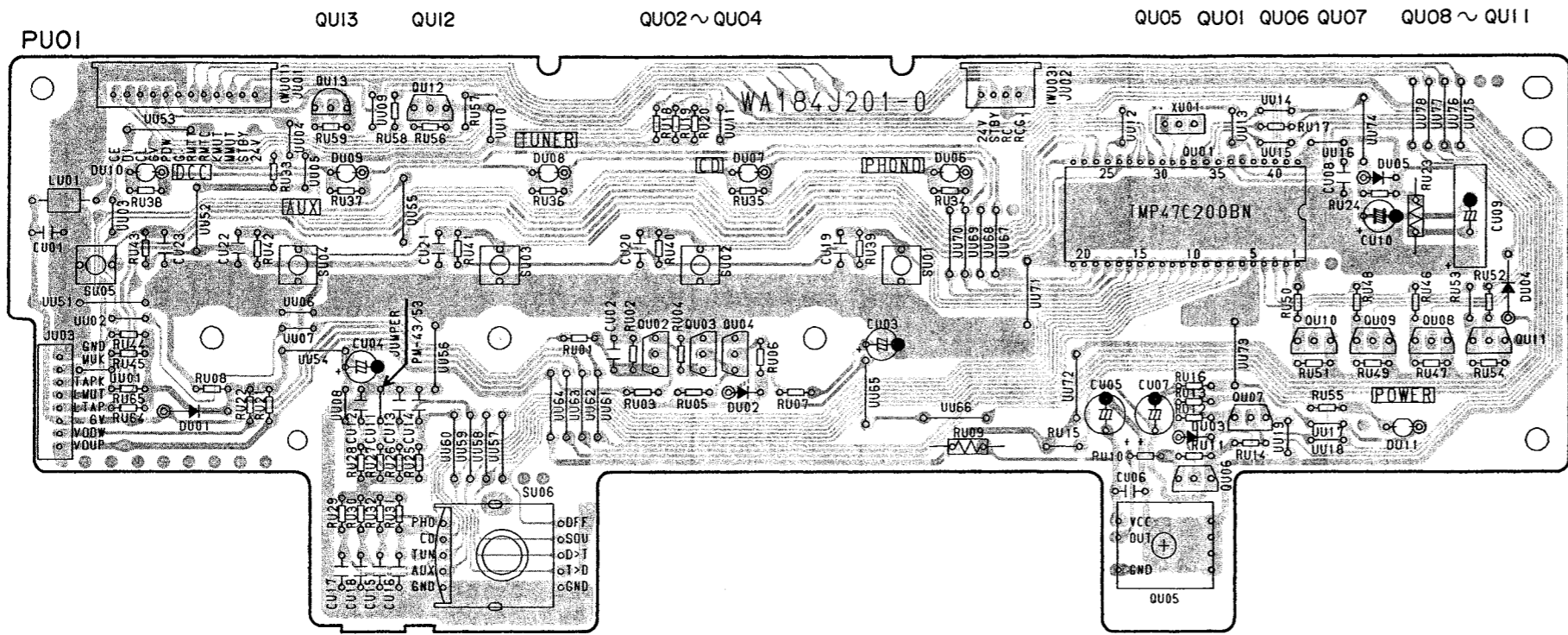

QU01 : TMP47C200BN

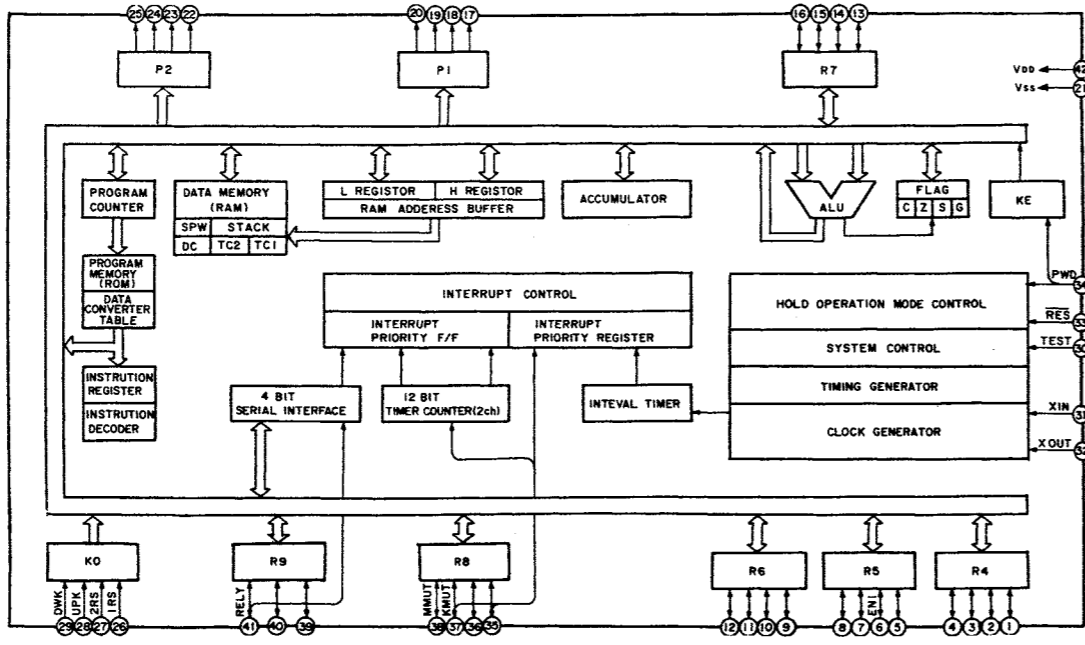

QU91 : LB1630

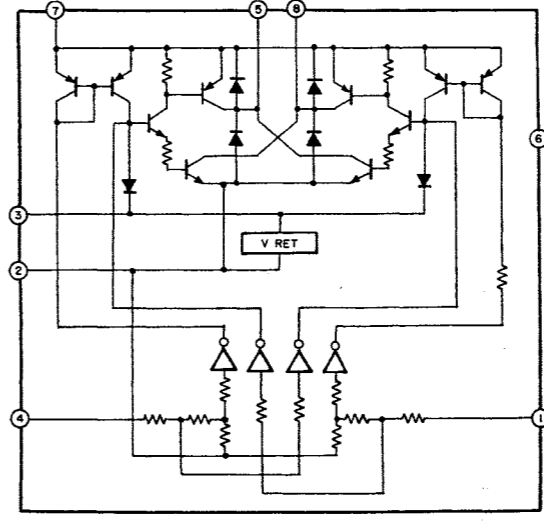

3. EXPLODED VIEW AND PARTS LIST

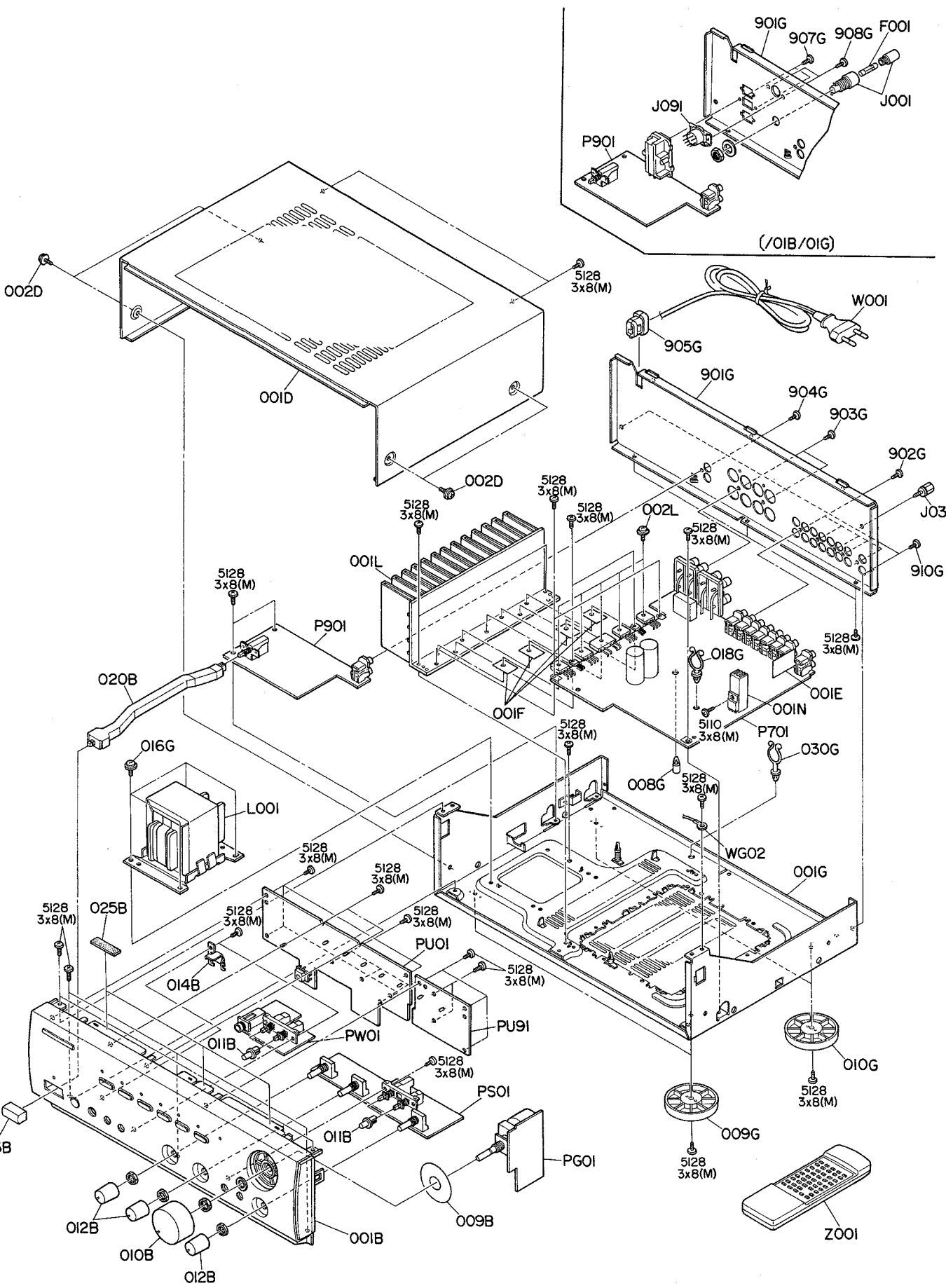

POS.NO	VERSION	PART NO. (FOR EUROPE)	DESCRIPTION	PART NO.
001B	/ 01B/ 02B / 05B	4822 426 51672	Front Panel Assembly (BLK)	185J248510
010B	/ 01G/ 02G	4822 426 51673	Front Panel Assembly (GLD)	185J248540
	/ 01B/ 02B / 05B	4822 413 41679	Knob, Volume (BLK)	063J154080
011B	/ 01G/ 02G	4822 413 41683	Knob, Volume (GLD)	063J154090
	/ 01B/ 02B / 05B	4822 410 60343	Button, Push (BLK)	058J270030
012B	/ 01G/ 02G	4822 410 60334	Button, Push (GLD)	058J270130
	/ 01B/ 02B / 05B	4822 413 41813	Knob, Tone (BLK)	185J154010
013B	/ 01G/ 02G	4822 413 41814	Knob, Tone (GLD)	185J154020
	/ 01B/ 02B / 05B	4822 410 62744	Button, Power (BLK)	285K270010
020B	/ 01G/ 02G	4822 410 62745	Button, Power (GLD)	285K270110
		4822 404 60772	Link, Power SW.	185J121010
002D		4822 502 12511	B.T.Screw (W/W) 3 x 8 (M)	51260308M0
001F		4822 466 62033	Insulator, DENKA Sheet	242H120020
009G		4822 462 42045	Leg, Front	183J057010
010G		4822 462 42048	Leg, Rear	183J057110
016G		4822 502 12511	B.T.Screw (W/ W) 3 x 8 (M)	51260308M0
902G		4822 502 13636	PH, Tap. Screw 3 x 8 (M)	51270308M0
903G		4822 502 13636	PH, Tap. Screw 3 x 8 (M)	51270308M0
904G		4822 502 13636	PH, Tap. Screw 3 x 8 (M)	51270308M0
905G		4822 532 60948	Bushing, AC Cord	450H259010
907G	/ 01B/ 01G	4822 502 13636	PH, Tap. Screw 3 x 8 (M)	51270308M0
908G	/ 01B/ 01G	4822 502 13636	PH, Tap. Screw 3 x 8 (M)	51270308M0
910G		4822 502 13636	PH, Tap. Screw 3 x 8 (M)	51270308M0
002L		4822 502 12512	B.T.Screw (W/ W) 3 x 12 (M)	51260312M0
001T		4822 736 21809	User Manual	184J851310
▲ F001	/ 01B/ 01G	4822 253 30415	Fuse T1.6A 250V	FS10160850
▲ F002	/ 01B/ 01G	4822 070 33152	Fuse T3.15A 250V	FS10315850
▲ J001	/ 01B/ 01G	4822 256 30233	Jack, Fuse Holder	YJ08000290
J031		4822 290 40297	Terminal, GND	YL03010280
▲ J091	/ 01B/ 01G	4822 272 10327	Voltage Selector	BY05080070
▲ J092	/ 01B/ 01G	4822 265 10092	Jack, AC Adapter	YJ04001240
▲ L001	/ 01B/ 01G / 01B/ 02B / 05B	4822 146 21743	Power Transformer	TS17650020
		4822 146 21744	Power Transformer	TS17650010
Z001		4822 218 10519	Unit K, Remoto Control	ZK185J0010

4. TEST EQUIPMENT REQUIRED FOR SERVICING

Item	Use
Distortion Analyzer	Distortion measurements
Audio Oscillator	Sinewave and squarewave signal source
ACVTVM	Voltage measurements (AC)
Oscilloscope	Waveform analysis and trouble shooting and ASO alignment
Circuit Tester	Trouble shooting
DCVTVM	Voltage measurements (DC)
AC Wattmeter	Monitors primary power to amplifier
Line Voltmeter	Monitors potential of primary power to amplifier
Variable Autotransformer	Adjust level of primery power to amplifier
Shorting Plug	Shorts amplifier input to eliminate noise pickup

5. IDLING CURRENT ADJUSTMENT

- Before switching the power ON, set the Master Volume control to the minimum position and the Balance and Tone controls to the center positions. Also set semi-fixed resistors R755 (L CH) and R756 (R CH) on PCB P701 to the center positions.
- Each of the cement resistors R769 (L CH) and R770 (R CH) on the PCB P701 is provided with three test points. Connect a digital voltmeter, set for the DC voltage input, to the test points at the two extremities of the three test points of R769 or R770.
- After the setup above, switch the power ON and adjust semi-fixed resistor R755 (L CH) or R756 (R CH) on PCB P701 according to the digital voltmeter reading. The target setting value is 18 mV (50 mA) for both the L CH and R CH.

Please refer to the table below.

Elapsed time after power ON	Idling current setting value
1 min. - 2 min.	17 mV
2 min. - 3 min.	17.5 mV
More than 3 min.	18 mV

Note on Safety:

Symbol ▲ Fire or electrical shock hazard. Only original parts should be used to replace any part marked with symbol ▲. Any other component substitution (other than original type), may increase risk of fire or electrical shock hazard.

6. USE OF SERVICE HOLE

- If the use of the service hole is required, remove the cover by cutting 10 bridges (A) using a tool such as a pair of cutters.
- During this work, be careful of the sharp edges at the cut positions.
- After using the service hole, rotate the cover and fix it using screws [3 x 6 (M)].

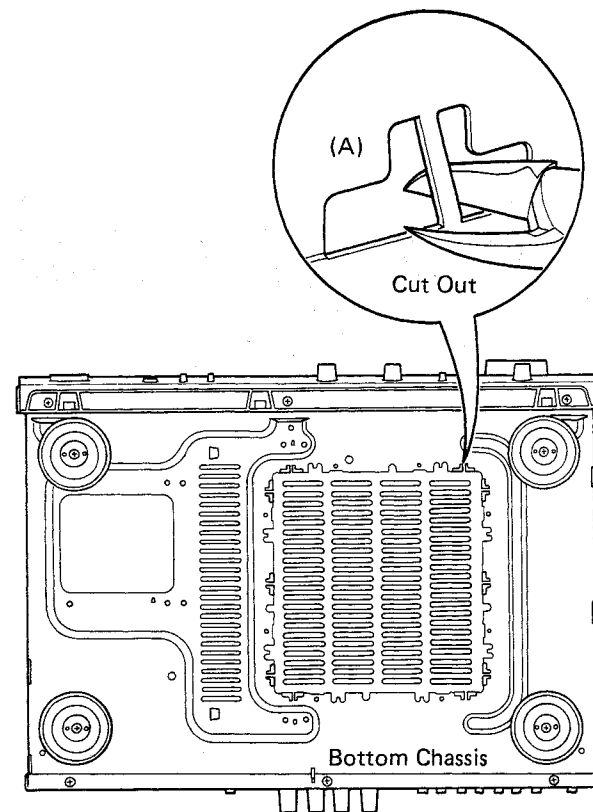

7. VOLTAGE CONVERSION

● EUROPEAN MODEL ONLY (/ 01)

To convert the unit to a different power source voltage, change the position as illustrated in the drawing below.

VOLTAGE SELECTOR

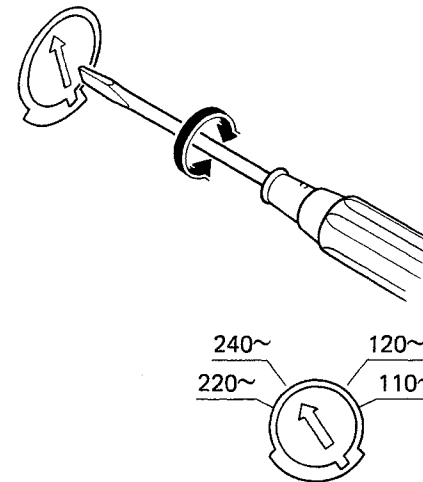

CAUTION
DISCONNECT POWER SUPPLY CORD FROM AC OUTLET BEFORE CONVERTING VOLTAGE.

8. HOW TO CHANGE THE SUPPLY VOLTAGE (/ 02 / 05 Versions)

With the / 05 Version, the rated supply voltage of 240V can be changed to 230V. In the same way, the 230V rated supply voltage of the / 02 Version can be changed to 240V.

Refer to the following diagram for the voltage change procedure.

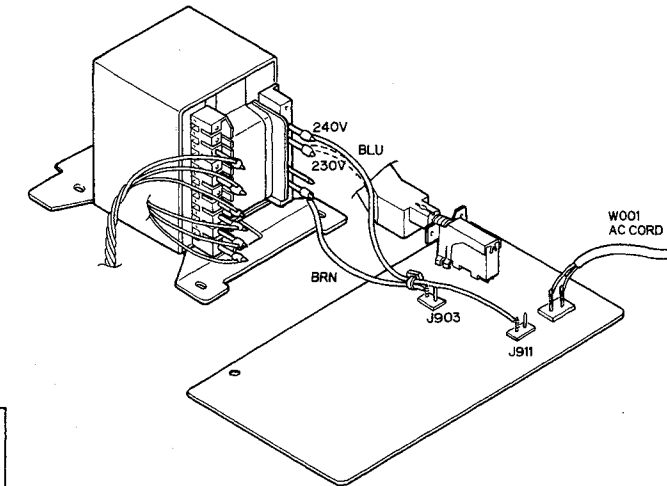

9. MICROPROCESSOR QU01 : TMP47C200BN

PIN NO.	PORT NAME	I/O	ACT	FUNCTION	PIN NO.	PORT NAME	I/O	ACT	FUNCTION		
1	R40	KMUT	O	L	SOURCE MUTE	22	P20	LDCC	O	L	LED INDICATOR DCC
2	R41	RMTC	O	L	TAPE OUT MUTE FOR DCC	23	P21	LTAP	O	L	LED INDICATOR TAPE
3	R42	RMTT	O	L	TAPE OUT MUTE FOR TAPE	24	P22	LMUT	O	L	LED INDICATOR MUTE
4	R43	MMUT	O	H	SPEAKER OUT MUTE	25	P23	STBY	O	H	STAND-BY OTHER CONTROL
5	R50	EN1	I	-	MODEL SELECT #1	26	K00	AUXK	I	L	KEY INPUT AUX
6	R51	OFFR	I	L	RECORDING OUT OFF	27	K01	DCKK	I	L	KEY INPUT DCC
7	R52	SOUR	I	L	RECORDING OUT SOURCE	28	K02	TAPK	I	L	KEY INPUT TAPE
8	R53	D2TR	I	L	RECORDING OUT COPY DCC→TAPE	29	K03	MUK	I	L	KEY INPUT MANUAL MUTE
9	R60	T2DR	I	L	RECORDING OUT COPY TAPE→DCC	30	TEST	TEST	-	-	NOT USED (GND)
10	R61	AUXR	I	L	RECORDING OUT AUX	31	XIN	XIN	-	-	CLOCK 4.00 MHz
11	R62	TUNR	I	L	RECORDING OUT TUNER	32	XOUT	XOUT	-	-	
12	R63	CDR	I	L	RECORDING OUT CD	33	RESET	RES	I	L	SYSTEM RESET
13	R70	PHOR	I	L	RECORDING OUT PHONO	34	HOLD	PDW	I	L	POWER DOWN CHECK
14	R71	PHOK	I	L	KEY INPUT PHONO	35	R80	PMC	I	L	REMOTE CONTROL (RC-5) INPUT
15	R72	CDK	I	L	KEY INPUT CD	36	R81	VODW	O	L	VOLUME CONTROL (DOWN)
16	R73	TUNK	I	L	KEY INPUT TUNER	37	R82	VOUP	O	L	VOLUME CONTROL (UP)
17	P10	LPHO	O	L	LED INDICATOR PHONO	38	R83	EN2	I	-	MODEL SELECT #2
18	P11	LECD	O	L	LED INDICATOR CD	39	R90	CE	O	H	SERIAL OUTPUT (ENABLE)
19	P12	LTUN	O	L	LED INDICATOR TUNER	40	R91	DL	O	H	SERIAL OUTPUT (DATA)
20	P13	LAUX	O	L	LED INDICATOR AUX	41	R92	CL	O	H	SERIAL OUTPUT (CLOCK)
21	VSS	VSS	-	-	GND	42	VDD	VDD	-	-	POWER SUPPLY +5.4V

10. ELECTRICAL PARTS LIST

ASSIGNMENT OF COMMON PARTS CODES.

RESISTOR
R*** : (1) GD05 x x x 140, Carbon film fixed resistor, ± 5% 1/4W
R*** : (2) GD05 x x x 160, Carbon film fixed resistor, ± 5% 1/6W

① — Resistance value
 Examples :
 ① Resistance value
 0.1Ω...001 10Ω...100 1kΩ...102 100kΩ...104
 0.5Ω...005 18Ω...180 2.7kΩ...272 680kΩ...684
 1Ω...010 100Ω...101 10kΩ...103 1MΩ...105
 6.8Ω...068 390Ω...391 22kΩ...223 4.7MΩ...475



(Note) Please distinguish 1/4W from 1/6W by the shape of parts used actually.

C*** : CERAMIC CAP.
 (1) DD1x x x x 370, Ceramic capacitor
 Disc type
 Temp.coeff.P350~N1000,50V
 ① ②
 Capacity value
 Tolerance

Examples
 ① Tolerance (Capacity deviation)
 ± 0.25pF ... 0
 ± 0.5pF ... 1
 ± 5% ... 5
 * Tolerance of COMMON PARTS handled here are as follows :
 0.5pF~ 5pF...± 0.25pF
 6pF~ 10pF...± 0.5pF
 12pF~ 560pF...± 5%
 ② Capacity value
 0.5pF...005 3pF...030 100pF...101
 1pF...010 10pF...100 220pF...221
 1.5pF...015 47pF...470 560pF...561

C*** : CERAMIC CAP.
 (1) DK16 x x x 300, High dielectric constant ceramic capacitor
 Disc type
 Temp.chara. 2B4, 50V
 ①
 Capacity value

Examples
 ② Capacity value
 100pF...101 1000pF...102 10000pF...103
 470pF...471 2200pF...222

C*** : ELECTROLY CAP. (), FILM CAP. ()
 (1) EA x x x x x x 10, Electrolytic capacitor
 One-way lead type, Tolerance ± 20%
 ① ②
 Working voltage
 Capacity value

Examples
 ① Capacity value
 0.1μF...104 4.7μF...475 100μF...107
 0.33μF...334 10μF...106 330μF...337
 1μF...105 22μF...226 1100μF...118
 2200μF...228
 ② Working voltage
 6.3V...006 25V...025
 10V...010 35V...035
 16V...016 50V...050

(2) DF15 x x x 350, Plastic film capacitor
 One-way type, Mylar ± 5% 50V
 ①
 Capacity value

Examples
 ① Capacity value
 0.001μF(1000pF)...102 0.1μF...104
 0.0018μF...182 0.56μF...564
 0.01μF...103 1μF...105
 0.015μF...153

NOTE : The above CODES (**R*****, **R*****, **C*****, **C***** and **C*****) are omitted on the schematic diagram in some case.
 On the occasion, be confirmed the common parts on the parts list.

POS.NO	VERSION	PART NO. (FOR EUROPE)	DESCRIPTION	PART NO.
PG01			PG01-MASTER VOLUME CIRCUIT BOARD	
CG01		4822 122 30043	MASTER VOLUME PCB	WA184J2040
RG01		4822 101 30832	Cermic Cap. 0.01μF +80% -20% 50V	DK18103310
			Variable Resistor 100K Ω (VB) x 2	RY01040230
PS01			PS01-TONE / DIRECT / LOUDNESS / BAL. CIRCUIT BOARD	
			TONE / DIRECT / LOUDNESS / BAL. PCB	WA184J1020
CE09		4822 124 90352	PS01-CAPACITORS	
CE10		4822 124 90352	Elect 10μF 16V	OA10601620
			Elect 10μF 16V	OA10601620
			PS01-CAPACITORS (COMMON)	
C***			Plastic Film Capacitor, ±5% 50V: CE01~CE08, CS01~CS04	
RE13		4822 101 30831	PS01-RESISTORS	
RE14		4822 101 30831	50K Ω (C), Variable Bass	RM05032000
			50K Ω (C), Variable Treble	RM05032000
RG51		4822 101 30828	100K Ω (MN), Variable Balance	RM01041540
			PS01-RESISTOR (COMMON)	
R***			Carbon Film Fixed Resistor, ±5%: RE01~RE12, RE51, RE52, RS01~RS04	
SS01		4822 276 13435	PS01-MISCELLANEOUS	
			Push Switch, Direct/ Loudness	SP04020600
PU01			PU01-U-COM CIRCUIT BOARD	
			U-COM PCB	WA184J2010
CU01		4822 122 40617	PU01-CAPACITORS	
CU02		4822 122 30043	Ceramic 0.1μF +80% -20% 50V	DD38104010
CU03		4822 124 90352	Ceramic 0.01μF +80% -20% 50V	DK18103310
CU04		4822 124 90352	Elect 10μF 16V	OA10601620
CU05		4822 124 90363	Elect 10μF 16V	OA10601620
CU06		4822 122 30043	Elect 220μF 10V	OA22701020
CU07		4822 124 90363	Ceramic 0.01μF +80% -20% 50V	DK18103310
CU08		4822 124 90363	Elect 220μF 10V	OA22701020
CU09		4822 122 40617	Ceramic 0.1μF +80% -20% 50V	DD38104010
CU10		4822 124 90406	Big Elect 0.022F 5.5V	EX22300530
			Elect 10μF 16V	OA10601620
CU19				
CU23		4822 122 30043	Ceramic 0.01μF +80% -20% 50V	DK18103310
			PU01-RESISTORS	
RU09		4822 050 21021	100 Ω ±5% 1/4W	GG05101140
RU15		4822 050 21021	100 Ω ±5% 1/4W	GG05101140
RU23		4822 050 21021	100 Ω ±5% 1/4W	GG05101140
			PU01-RESISTORS (COMMON)	
R***			Carbon Film Fixed Resistor, ±5%: RU01~RU08, RU10~RU14, RU16~RU22, RU24~RU59, RU64, RU65	
			PU01-SEMICONDUCTORS	
DU01		4822 130 32508	Diode DSF10C/ RL103E	HD20003000
DU02		4822 130 33305	Diode 1SS176, etc.	HD20002000
DU04		4822 130 32508	Diode DSF10C/ RL103E	HD20003000
DU05		4822 130 33305	Diode 1SS176, etc.	HD20002000
DU06				
DU11		4822 130 80326	L.E.D. LT3D8B (RED)	HI10062320

POS.NO	VERSION	PART NO. (FOR EUROPE)	DESCRIPTION	PART NO.
QU01		4822 209 32576	Microprocessor TMP47C200BN	HU10085050
QU02		4822 130 60839	Transistor 2SC2458 (Y/GR)	HT324582B0
QU03		4822 130 60839	Transistor 2SC2458 (Y/GR)	HT324582B0
QU04		4822 130 60839	Transistor 2SC2458 (Y/GR)	HT324582B0
QU05		4822 130 82139	Photo Unit PAS-C0618	HW10005550
QU06		4822 130 60107	Transistor 2SA1048 (Y/GR)	HT110482B0
QU07		4822 130 60839	Transistor 2SC2458 (Y/GR)	HT324582B0
QU08				
QU12		4822 130 60107	Transistor 2SA1048 (Y/GR)	HT110482B0
QU13		4822 130 60696	Transistor 2SC1627 (O/Y)	HT316272B0
			PU01-MISCELLANEOUS	
LU01		4822 158 60605	Ferrite Core	FC90050060
SU01		4822 276 20508	Push Switch, Tact	SP01011280
SU05				
XU01		4822 242 72223	Ceramic Resonator 4.00MHz	FQ04004030
			PU91-MOTOR VOL. DRIVE CIRCUIT BOARD	
PU91			MOTOR VOL. DRIVE PCB	WA184J2020
			PU91-CAPACITORS	
CU91		4822 122 30043	Ceramic 0.01 μ F +80% -20% 50V	DK18103310
CU93		4822 124 90352	Elect 10 μ F 16V	OA10601620
			PU91-RESISTORS (COMMON)	
R***			Carbon Film Fixed Resistor, \pm 5%: RU91~RU96	
			PU91-SEMICONDUCTORS	
DU91		4822 130 32508	Diode DSF10C/ RL103E	HD20003000
DU92		4822 130 32508	Diode DSF10C/ RL103E	HD20003000
DU93		4822 130 32508	Diode DSF10C/ RL103E	HD20003000
DU94		4822 130 80326	L.E.D. LT3D8B (RED)	HI10062320
DU95		4822 130 80326	L.E.D. LT3D8B (RED)	HI10062320
QU91		4822 209 73287	IC LB1630	HC10235030
			PU91-MISCELLANEOUS	
SU91		4822 276 20508	Push Switch, Tact	SP01011280
			PW01-HEADPHONE / SPK 1/2 SW. CIRCUIT BOARD	
PW01			HEADPHONE/SPK 1/2 SW. PCB	WA184J2050
CW01	/02B/02G	4822 122 30043	Ceramic Cap. 0.01 μ F +80% -20% 50V	DK18103310
CW02	/02B/02G	4822 122 30043	Ceramic Cap. 0.01 μ F +80% -20% 50V	DK18103310
RW01		4822 116 60455	Resistor 270 Ω \pm 5% 2W Metal	NK05271020
RW02		4822 116 60455	Resistor 270 Ω \pm 5% 2W Metal	NK05271020
JW01	/01B/02B /05B	4822 267 31274	Jack, Headphone	YJ01003340
	/01G/02G	4822 267 31365	Jack, Headphone	YJ01003410
SW01		4822 276 12423	Push Switch, Speaker 1/2	SP02021010
			P701-MAIN CIRCUIT BOARD	
P701			MAIN PCB	WA184J1010
			P701-CAPACITORS	
CN01		4822 124 22274	Elect 4.7 μ F 50V	OA47505020
CN02		4822 124 41543	Elect 1 μ F 50V	OA10505020
CN04		4822 124 22275	Elect 47 μ F 10V	OA47601020
CN05		4822 124 23417	Elect 33 μ F 10V	OA33601020
CN06		4822 124 22273	Elect 0.47 μ F 50V	OA47405020

POS.NO	VERSION	PART NO. (FOR EUROPE)	DESCRIPTION	PART NO.	
CN07 CN08		4822 124 41539 4822 122 40617	Elect 47 μ F 16V Ceramic 0.1 μ F +80% -20% 50V	OA47601620 DD38104010	
CV01 } CV14 CV15 }	/02B/ 02G	4822 122 30043	Ceramic 0.01 μ F +80% -20% 50V	DK18103310	
CV28 CV29 }		4822 126 11069	Ceramic 150pF \pm 10% 50V	DA16151110	
CV32 CV33 }		4822 122 30043	Ceramic 0.01 μ F +80% -20% 50V	DK18103310	
CV34 CV35 }		4822 124 22274	Elect 4.7 μ F 50V	OA47505020	
CV38 CV41 }		4822 124 22274	Elect 4.7 μ F 50V	OA47505020	
CV44		4822 126 11127	Ceramic 470pF \pm 10% 50V	DA16471110	
C401 C402 C403		/01B/ 01G /05B	4822 122 30043 4822 122 30043 4822 126 11069	Ceramic 0.01 μ F +80% -20% 50V Ceramic 0.01 μ F +80% -20% 50V Ceramic 150pF \pm 10% 50V	DK18103310 DK18103310 DA16151110
C404		/01B/ 01G /05B	4822 126 11069	Ceramic 150pF \pm 10% 50V	DA16151110
C405 C406 C407 C408		/02B/ 02G /02B/ 02G	4822 124 90352 4822 124 90352 4822 124 41539 4822 124 41539	Elect 10 μ F 16V Elect 10 μ F 16V Elect 47 μ F 16V Elect 47 μ F 16V	OA10601620 OA10601620 OA47601620 OA47601620
C409 C410			4822 126 11127 4822 126 11127	Ceramic 470pF \pm 10% 50V Ceramic 470pF \pm 10% 50V	DA16471110 DA16471110
C417 C418 C421 C422	4822 124 90357 4822 124 90357 4822 124 41535 4822 124 41535		Elect 2.2 μ F 50V Elect 2.2 μ F 50V Elect 100 μ F 25V Elect 100 μ F 25V	OA22505020 OA22505020 OA10702520 OA10702520	
C701 C702 C703 C704 C705 C706 C707 C708 C709 C710	4822 124 22571 4822 124 22571 4822 126 10364 4822 126 10364 4822 124 90354 4822 124 90354 4822 126 11069 4822 126 11069 4822 126 11068 4822 126 11068		Elect 10 μ F 50V Elect 10 μ F 50V Ceramic 100pF \pm 10% 50V Ceramic 100pF \pm 10% 50V Elect 100 μ F 16V Elect 100 μ F 16V Ceramic 150pF \pm 10% 50V Ceramic 150pF \pm 10% 50V Ceramic 39pF \pm 10% 50V Ceramic 39pF \pm 10% 50V	OA10605020 OA10605020 DA16101110 DA16101110 OA10701620 OA10701620 DA16151110 DA16151110 DA16390110 DA16390110	
C711 C712 C713 C714 C715 C716 C717 C718 C719 C720	4822 121 43127 4822 121 43127 4822 121 43128 4822 121 43128 4822 124 90362 4822 124 90362 4822 124 90366 4822 124 90366 4822 124 90361 4822 124 90361		Film 5pF \pm 10% 50V Film 5pF \pm 10% 50V Film 10pF \pm 10% 50V Film 10pF \pm 10% 50V Elect 22 μ F 50V Elect 22 μ F 50V Elect 220 μ F 50V Elect 220 μ F 50V Elect 22 μ F 25V Elect 22 μ F 25V	DF56050090 DF56050090 DF56100090 DF56100090 OA22605020 OA22605020 OA22705020 OA22705020 OA22602520 OA22602520	
C721 C723 C724 C751 C752 C753 } C756 C761 } C764	/02B/ 02G		4822 122 40617 4822 122 40617 4822 122 40617 4822 124 90354 4822 124 90354 4822 121 50548 4822 122 30043	Ceramic 0.1 μ F +80% -20% 50V Ceramic 0.1 μ F +80% -20% 50V Ceramic 0.1 μ F +80% -20% 50V Elect 100 μ F 16V Elect 100 μ F 16V Film 120pF \pm 5% 125V Ceramic 0.01 μ F +80% -20% 50V	DD38104010 DD38104010 DD38104010 OA10701620 OA10701620 DF55121510 DK18103310
▲C765 ▲C766			4822 124 42042 4822 124 42042	Elect 8200 μ F 45V Elect 8200 μ F 45V	OB82804510 OB82804510
C801 C802 C803 C805 C806			4822 122 30043 4822 122 30043 4822 124 41543 4822 124 90356 4822 124 41541	Ceramic 0.01 μ F +80% -20% 50V Ceramic 0.01 μ F +80% -20% 50V Elect 1 μ F 50V Elect 1000 μ F 35V Elect 470 μ F 35V	DK18103310 DK18103310 OA10505020 OA10803520 OA47703520

POS.NO	VERSION	PART NO. (FOR EUROPE)	DESCRIPTION	PART NO.
C807 }		4822 124 90362	Elect 22 μ F 50V	OA22605020
C810		4822 124 90366	Elect 220 μ F 50V	OA22705020
C811		4822 124 22695	Elect 2200 μ F 35V	OA22803520
C812		4822 124 90362	Elect 22 μ F 50V	OA22605020
C813				
G701		4822 121 20263	Component RFD2B474K	BF47400010
			P701-CAPACITORS (COMMON)	
C***			Plastic Film Capacitor, \pm 10%: CN03, C419, C420	
C***			Plastic Film Capacitor, \pm 5%: CV39, CV40, C411~C416, C757, C758, (C759, C760 [/ 02B/ 02G/ 05B])	
C***			High Dielectric Constant Ceramic Capacitor, 50V: (C403, C404 [/ 02B/ 02G])	
			P701-RESISTORS	
RN01		4822 052 10102	1K Ω \pm 5% 1/6W	GG05102160
RN02		4822 052 10102	1K Ω \pm 5% 1/6W	GG05102160
RN15		4822 050 23303	33K Ω \pm 5% 1/4W	GG05333140
▲ RN19		4822 113 90119	22 Ω \pm 2% 1/4W, Fusible	NF02220140
RN20		4822 050 21503	15K Ω \pm 5% 1/2W	GG05153120
▲ R417		4822 111 90731	47 Ω \pm 2% 1/4W, Fusible	NF02470140
▲ R418		4822 111 90731	47 Ω \pm 2% 1/4W, Fusible	NF02470140
R713		4822 050 23303	33K Ω \pm 5% 1/4W	GG05333140
R714		4822 050 23303	33K Ω \pm 5% 1/4W	GG05333140
R719	/ 02B/ 02G / 05B	4822 050 26809	68 Ω \pm 5% 1/6W	GG05680160
R720	/ 02B/ 02G / 05B	4822 050 26809	68 Ω \pm 5% 1/6W	GG05680160
R721	/ 02B/ 02G / 05B	4822 117 10159	120 Ω \pm 5% 1/6W	GG05121160
R722	/ 02B/ 02G / 05B	4822 117 10159	120 Ω \pm 5% 1/6W	GG05121160
R732		4822 053 10222	2.2K Ω \pm 5% 1W	GA05222010
▲ R733		4822 116 60313	10 Ω \pm 5% 1/2W, Fusible	NH05100120
▲ R734		4822 116 60313	10 Ω \pm 5% 1/2W, Fusible	NH05100120
R755		4822 100 11426	470 Ω , Trimming	RA04710780
R756		4822 100 11426	470 Ω , Trimming	RA04710780
R757				
R760		4822 052 10101	100 Ω \pm 5% 1/6W	GG05101160
R761		4822 052 10102	1K Ω \pm 5% 1/6W	GG05102160
R762		4822 052 10102	1K Ω \pm 5% 1/6W	GG05102160
R763		4822 053 10331	330 Ω \pm 5% 1W	GA05331010
R764		4822 053 10331	330 Ω \pm 5% 1W	GA05331010
R765				
R768		4822 116 83963	2.2 Ω \pm 5% 1/4W	GG05022140
R769		4822 116 82049	0.18 Ω x 2 3W	BZ10182010
R770		4822 116 82049	0.18 Ω x 2 3W	BZ10182010
R771		4822 052 10221	220 Ω \pm 5% 1/6W	GG05221160
R772		4822 052 10221	220 Ω \pm 5% 1/6W	GG05221160
R773		4822 053 11109	10 Ω \pm 5% 2W	GA05100020
R774		4822 053 11109	10 Ω \pm 5% 2W	GA05100020
R775		4822 117 10002	2.2K Ω \pm 5% 1/2W	GG05222120
▲ R801		4822 117 10158	1 Ω \pm 5% 1/4W	GG05010140
▲ R802		4822 117 10158	1 Ω \pm 5% 1/4W	GG05010140
▲ R803		4822 111 50613	22 Ω \pm 5% 1/2W	GG05220120
			P701-RESISTORS (COMMON)	
R***			Carbon Film Fixed Resistor, \pm 5%: RN03~RN14, RN16~RN18, RN21~RN25, RV01~RV17, RV19~RV28, RV30~RV32, R401~R416, R419, R420, R703~R712, R715~R718, (R719~R722 [/ 01B/ 01G]) R723~R731, R735~R739, R751~R754, R777, R778	

POS.NO	VERSION	PART NO. (FOR EUROPE)	DESCRIPTION	PART NO.
P701-SEMICONDUCTORS				
DN01		4822 130 80837	Diode HSS81	HD20027010
DN02		4822 130 80837	Diode HSS81	HD20027010
DN03		4822 130 33305	Diode 1SS176, etc.	HD20002000
DN04		4822 130 33305	Diode 1SS176, etc.	HD20002000
DN05		4822 130 80839	Diode S5688G	HD20029050
DN06		4822 130 33305	Diode 1SS176, etc.	HD20002000
DV01		4822 130 33305	Diode 1SS176, etc.	HD20002000
DV02		4822 130 33305	Diode 1SS176, etc.	HD20002000
D701		4822 130 33305	Diode 1SS176, etc.	HD20002000
D704		4822 130 80273	Zener NTJ8.2C	HD30821000
D705		4822 130 80322	Zener NTJ15B	HD31501000
D706		4822 130 83438	Diode D5SB-20	HE20016290
▲ D707		4822 130 80839	Diode S5688G	HD20029050
▲ D801	/ 02B/ 02G	4822 130 80839	Diode S5688G	HD20029050
▲ D802	/ 05B	4822 130 80839	Diode S5688G	HD20029050
▲ D803	/ 02B/ 02G	4822 130 80839	Diode S5688G	HD20029050
▲ D804	/ 05B	4822 130 80839	Diode S5688G	HD20029050
▲ D805	/ 02B/ 02G	4822 130 80839	Diode S5688G	HD20029050
▲ D806	/ 05B	4822 130 80839	Diode S5688G	HD20029050
▲ D807	/ 02B/ 02G	4822 130 80839	Diode S5688G	HD20029050
▲ D808	/ 05B	4822 130 80839	Diode S5688G	HD20029050
▲ D809	/ 02B/ 02G	4822 130 80839	Diode S5688G	HD20029050
▲ D810	/ 05B	4822 130 80839	Diode S5688G	HD20029050
D811		4822 130 32508	Diode RL103E/ DSF10C	HD20003000
QN01		4822 130 43233	Transistor 2SC2240 (GR/ BL)	HT322402A0
QN02		4822 130 43233	Transistor 2SC2240 (GR/ BL)	HT322402A0
QN03		4822 130 42951	Transistor 2SA970 (GR/ BL)	HT109702A0
QN04		4822 209 83312	IC TA7317P	HC10042050
QN05		4822 130 60107	Transistor 2SA1048 (Y/ GR)	HT110482B0
QN06		4822 130 60839	Transistor 2SC2458 (Y/ GR)	HT324582B0
QV01		4822 209 73321	IC LC7822	HC10241030
QV02		4822 209 73321	IC LC7822	HC10241030
QV03		4822 130 43819	Transistor 2SC2878 (A/ B)	HT328782A0
QV06		4822 130 43819	Transistor 2SC2878 (A/ B)	HT328782A0
Q401		4822 209 73064	IC NJM2068DD	HC10053090
Q701		4822 130 42951	Transistor 2SA970 (GR/ BL)	HT109702A0
Q702		4822 130 42951	Transistor 2SA970 (GR/ BL)	HT109702A0
Q703		4822 130 43233	Transistor 2SC2240 (GR/ BL)	HT322402A0
Q704		4822 130 43233	Transistor 2SC2240 (GR/ BL)	HT322402A0
Q705		4822 209 83732	IC AN7062	HC10066020
Q707		4822 130 43819	Transistor 2SC2878 (A/ B)	HT328782A0
Q708		4822 130 43819	Transistor 2SC2878 (A/ B)	HT328782A0
Q751		4822 130 60117	Transistor 2SC3419 (Y)	HT334191Y0
Q752		4822 130 60117	Transistor 2SC3419 (Y)	HT334191Y0
Q753		4822 130 43233	Transistor 2SC2240 (GR/ BL)	HT322402A0
Q754		4822 130 43233	Transistor 2SC2240 (GR/ BL)	HT322402A0
Q755		4822 130 42951	Transistor 2SA970 (GR/ BL)	HT109702A0
Q756		4822 130 42951	Transistor 2SA970 (GR/ BL)	HT109702A0
▲ Q757		4822 130 62335	Transistor 2SD2033	HT420331E0
▲ Q758		4822 130 62335	Transistor 2SD2033	HT420331E0
▲ Q759		4822 130 62334	Transistor 2SB1353	HT213531E0
▲ Q760		4822 130 62334	Transistor 2SB1353	HT213531E0
▲ Q761		4822 130 61319	Transistor 2SC3181 (R/ O)	HT331812A0
▲ Q762		4822 130 61319	Transistor 2SC3181 (R/ O)	HT331812A0
▲ Q763		4822 130 43018	Transistor 2SA1264 (R/ O)	HT112642A0
▲ Q764		4822 130 43018	Transistor 2SA1264 (R/ O)	HT112642A0
Q765		4822 130 90347	Photo Unit PC-817	HW10006320
Q766		4822 130 90347	Photo Unit PC-817	HW10006320
▲ Q801		4822 209 62423	IC 78M06F	HC3850609F
▲ Q802		4822 209 80675	IC 78M18F	HC3851809F
▲ Q803		4822 209 31788	IC 79M18F	HC3951809F

POS.NO	VERSION	PART NO. (FOR EUROPE)	DESCRIPTION	PART NO.
P701-MISCELLANEOUS				
JV01		4822 290 81598	Terminal, 2P RCA	YT02021130
JV02		4822 290 81603	Terminal, 4P RCA	YT02041030
JV03		4822 290 81603	Terminal, 4P RCA	YT02041030
JV04		4822 290 81603	Terminal, 4P RCA	YT02041030
J401		4822 290 81598	Terminal, 2P RCA	YT02021130
J701		4822 290 61179	Terminal, Speaker	YT01080120
▲ LN01		4822 280 70354	Relay VB24MBU	LY20240310
L751		4822 157 63085	Air Coil, SPK	ML08010010
L752		4822 157 63085	Air Coil, SPK	ML08010010
P901-POWER SW. / AC FUSE CIRCUIT BOARD				
P901			POWER SW. / AC FUSE PCB	WA184J2030
P901-CAPACITORS				
C901	/02B/02G	4822 122 30043	Ceramic 0.01 μ F +80% -20% 50V	DK18103310
C991		4822 122 40617	Ceramic 0.1 μ F +80% -20% 50V	DD38104010
▲ G901	/01B/01G /02B/02G	4822 121 43732	Film 0.01 μ F \pm 20% 250V AC	DF77103500
▲ G901	/05B	4822 122 33276	Ceramic 0.01 μ F \pm 20% 50V	DK17103840
▲ G902	/01B/01G	4822 121 43732	Film 0.01 μ F \pm 20% 250V AC	DF77103500
P901-SEMICONDUCTORS				
D901	/01B/01G	4822 130 33305	Diode 1SS176, etc.	HD20002000
D902	/01B/01G	4822 130 33305	Diode 1SS176, etc.	HD20002000
P901-MISCELLANEOUS				
▲ F901	/02B/02G /05B	4822 253 30415	Fuse T1.6A 250V	FS10160850
▲ J907	/01B/01G	4822 267 40815	Jack, AC Outlet 3P	YJ04001470
J991		4822 267 41009	Terminal, 2P RCA	YT02020890
▲ L901	/01B/01G	4822 280 20517	Relay V524MBU	LY10240190
▲ S901		4822 276 12924	Push Switch, Power	SP01011540
<p>NOTE ON SAFETY : Symbol ▲ Fire or electrical shock hazard. Only original parts should be used to replace any part marked with symbol ▲ . Any other component substitution (other than original type), may increase risk of fire or electrical shock hazard.</p>				