

Service Manual

80PM65
74PM63 / 01B / 02B
/ 01G / 02G

Integrated stereo amplifier

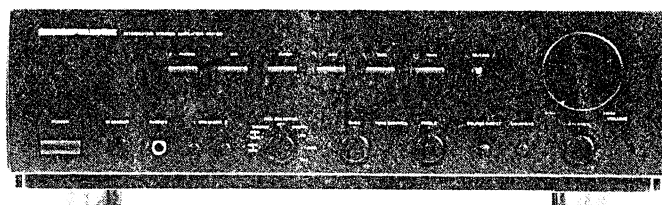

TABLE OF CONTENTS

SECTION	PAGE
1. BLOCK DIAGRAM	2
2. SCHEMATIC DIAGRAM AND PARTS LOCATION (Pattern Side).....	4
3. EXPLODED VIEW AND PARTS LIST	17
4. TEST EQUIPMENT REQUIRED FOR SERVICING	19
5. IDLING CURRENT ADJUSTMENT	19
6. USE OF SERVICE HOLE	19
7. VOLTAGE CONVERSION	20
8. HOW TO CHANGE THE SUPPLY VOLTAGE.....	20
9. MICROPROCESSOR	20
10. ELECTRICAL PARTS LIST	21

marantz®

model PM-63

PM-65

First issue : 1993
4822 725 51031

DOC 70 017

MARANTZ DESIGN AND SERVICE

Using superior design and selected high grade components, MARANTZ company has created the ultimate in stereo sound. Only **original MARANTZ parts** can insure that your MARANTZ product will continue to perform to the specifications for which it is famous.

Parts for your MARANTZ equipment are generally available at our National Marantz Subsidiary or Agent.

MARANTZ EUROPE B.V.
P.O. Box 80002
Building SFF 2
5600 JB Eindhoven
The Netherlands
Phone : +31-40-732241
Fax : +31-40-735578

ORDERING PARTS

Parts can be ordered either by mail or by telex. In both cases, the correct part number has to be specified. The following information must be supplied to eliminate delays in processing your order:

1. Complete address
2. Complete part numbers and quantities required
3. Description of parts
4. Model number for which the part is required
5. Way of shipment
6. Signature: any order form or telex must be signed, otherwise such part order will be considered as null and void.

ADDRESSES

AUSTRALIA MARANTZ AUSTRALIA Figtree Drive Australia Centre Homebush, NSW 2140 AUSTRALIA	FINLAND MARANTZ Kuortaneagatan 1 00520 Helsingfors 52 Finland	ITALY MARANTZ ITALIANA SPA Piazza IV Novembre 3 20124 Milano Italy	NORWAY MARANTZ Postboks 7034 Assiden 3007 Drammen Norway	SPAIN MARANTZ SPAIN Martinez Vilegas 2 Apartado 2065 Madrid 28027 Spain
AUSTRIA MARANTZ Hietzinger Kai 137a 1130 Wien Austria	FRANCE MARANTZ FRANCE 4 Rue Bernard Palissy 92600 Asnières France	JAPAN MARANTZ JAPAN INC. 35-1, 7-chome, Sagamiyone Sagamihara-shi, Kanagawa Japan	PORTUGAL COREL Av. da Liberdade 211-2 Esq. 1200 Lisboa Portugal	SWEDEN MARANTZ Box 1324 17125 Solna Sweden
BELGIUM MARANTZ EUROPE B.V. Div. Benelux P.O.Box 80002 Building SFF 2 5600 JB Eindhoven The Netherlands	GERMANY MARANTZ GERMANY GmbH Kleine Heide 12 Postfach 4802 Halle-Westfalen Germany	KUWAIT AL ALAMIAH ELECTRONICS P.O.Box 8196 Salmiah 22052 Kuwait	SAUDI ARABIA AL ALAMIAH ELECTRONICS P.O.Box 5954 University Street Riyadh 11432 Saudi Arabia	SWITZERLAND MARANTZ SWITZERLAND Postfach 8010 Zürich-Müllingen Switzerland
CHILE MARANTZ DIVISION OF PHILIPS S.A. Av.Santa Maria 0760 Casilla 2687 Santiago Chile	GREAT BRITAIN MARANTZ HiFi UK Ltd. Kingsbridge House Padbury Oaks 575-583 Bath Road Lingford Middlesex UB7 0EH, U.K.	NETHERLANDS MARANTZ EUROPE B.V. Div. Benelux P.O.Box 80002 Building SFF 2 5600 JB Eindhoven The Netherlands	SOUTH AFRICA MARANTZ S.A. 10 Bond Street Randburg 2194 P.O. Box 7703 Johannesburg 2000 South Africa	TRADING MARANTZ TRADING P.O.Box 20008 Building SFF 2 5600 JB Eindhoven The Netherlands
DENMARK MARANTZ Horsvinget 5 2630 Tastrup Denmark	GREECE ADAMCO ELECTR. SA P.O.Box 21025 Hippocratus Str. 188 Athens 11471 Greece			

All of the above locations are fully equipped to take care of your total service needs or can advise you. Because various countries have differing configuration requirements, it is necessary that you contact the service facility in your particular country. In the event that there is no service location listed for your country, please contact the nearest facility for the necessary assistance.

In case of difficulties, do not hesitate to contact the Technical Department at above mentioned address.

TECHICAL SPECIFICATIONS (DIN)

Power output
RMS 8 ohms (20 Hz - 20 kHz) 70 / 95 W
DIN 8 ohms / 4 ohms 80 / 115W

IHF dynamic power
8 ohms / 4 ohms 105 / 140W
THD at 8 ohms RMS rated output 0.007 %
Intermodulation distortion 0.007 %
Damping factor 120

Magnetic cartridge input
Input sensitivity impedance 2.5 mV / 47 k ohms
Accuracy of frequency response to RIAA 0.5 dB
Signal to noise ratio 94 dB

Tuner / CD / Aux / Tape inputs
Input sensitivity impedance 150 mV / 33 k ohms
Signal to noise ratio 104 dB
Frequency response (- 1 dB) 10 - 70 kHz
Tone characteristic (100 Hz and 10 kHz) ± 6 dB
Channel separation > 85 dB

General
Power Requirements
/ 01B / 01G version (4 voltages) 110 / 120 / 220 / 240 V AC, 50 / 60 Hz
/ 02B version 230 V AC, 50 Hz
Dimensions
Panel width 420 mm
Panel Height 118 mm
Depth 300 mm
Weight
Unit alone 6.9 kg

Specifications subject to change without prior notice.

1. BLOCK DIAGM

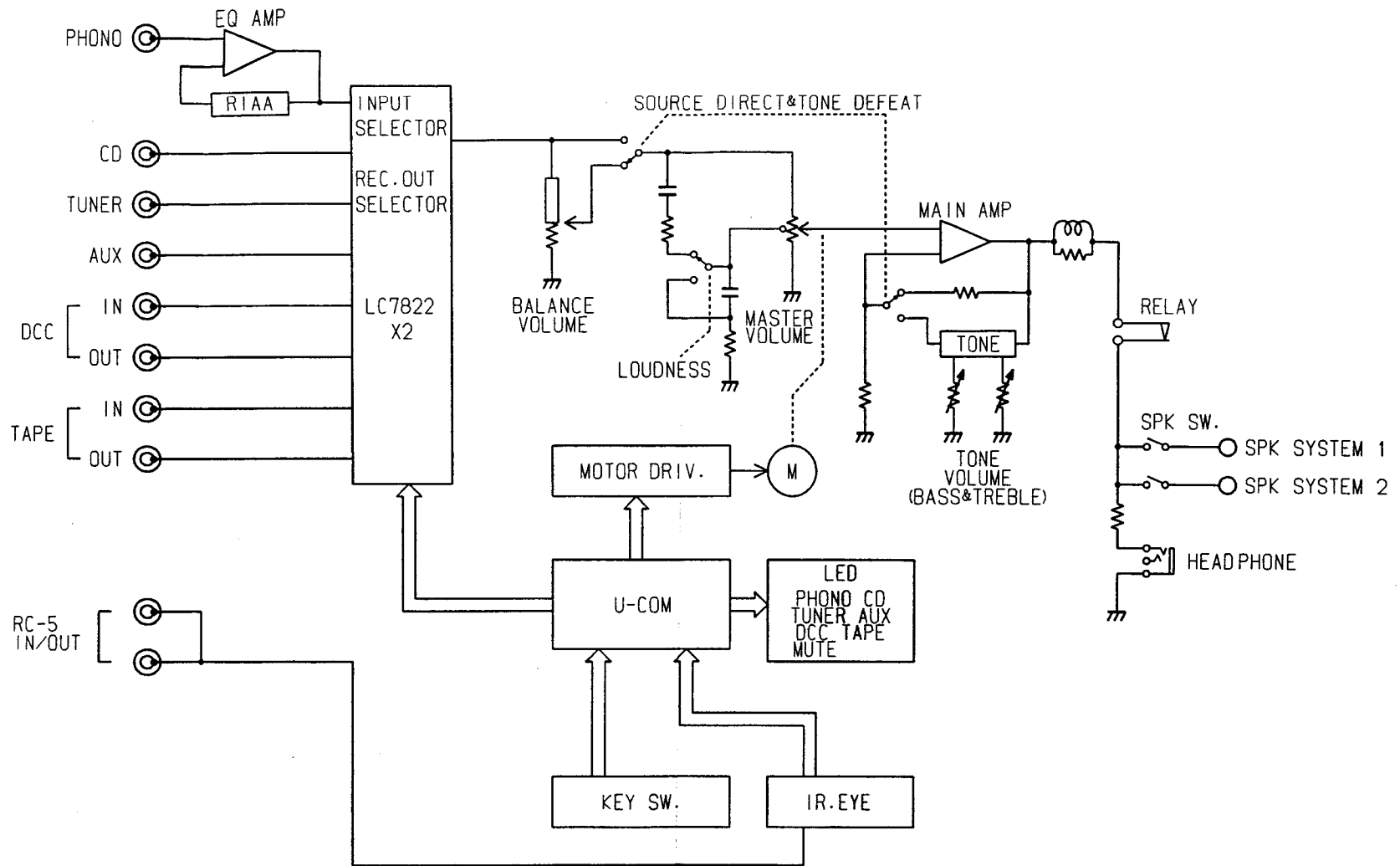

2. SCHEMATIC DIAGRAM AND PARTS LOCATION (Pattern Side)

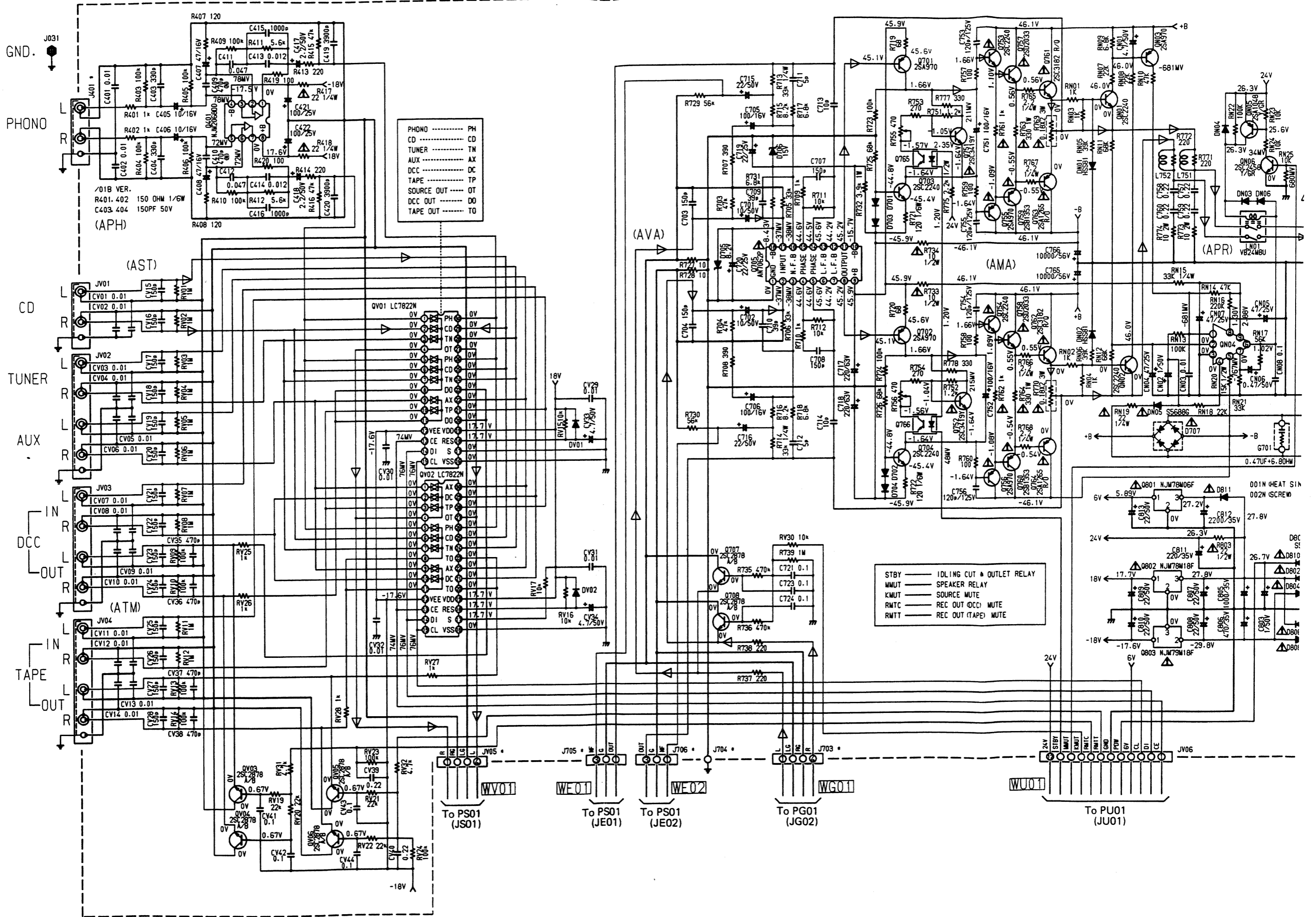

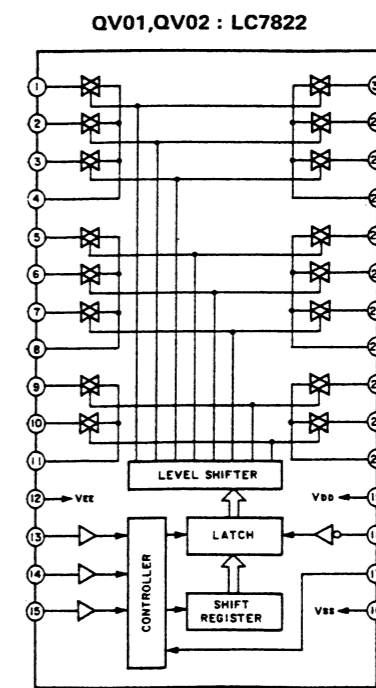
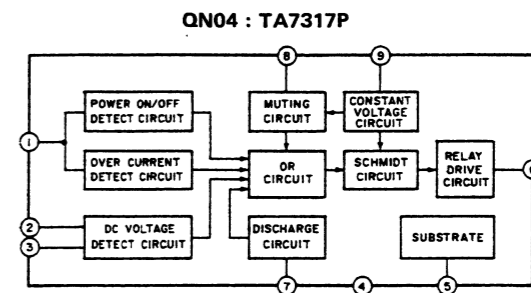
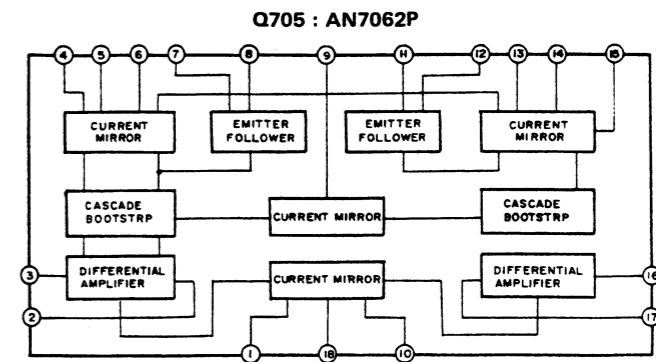
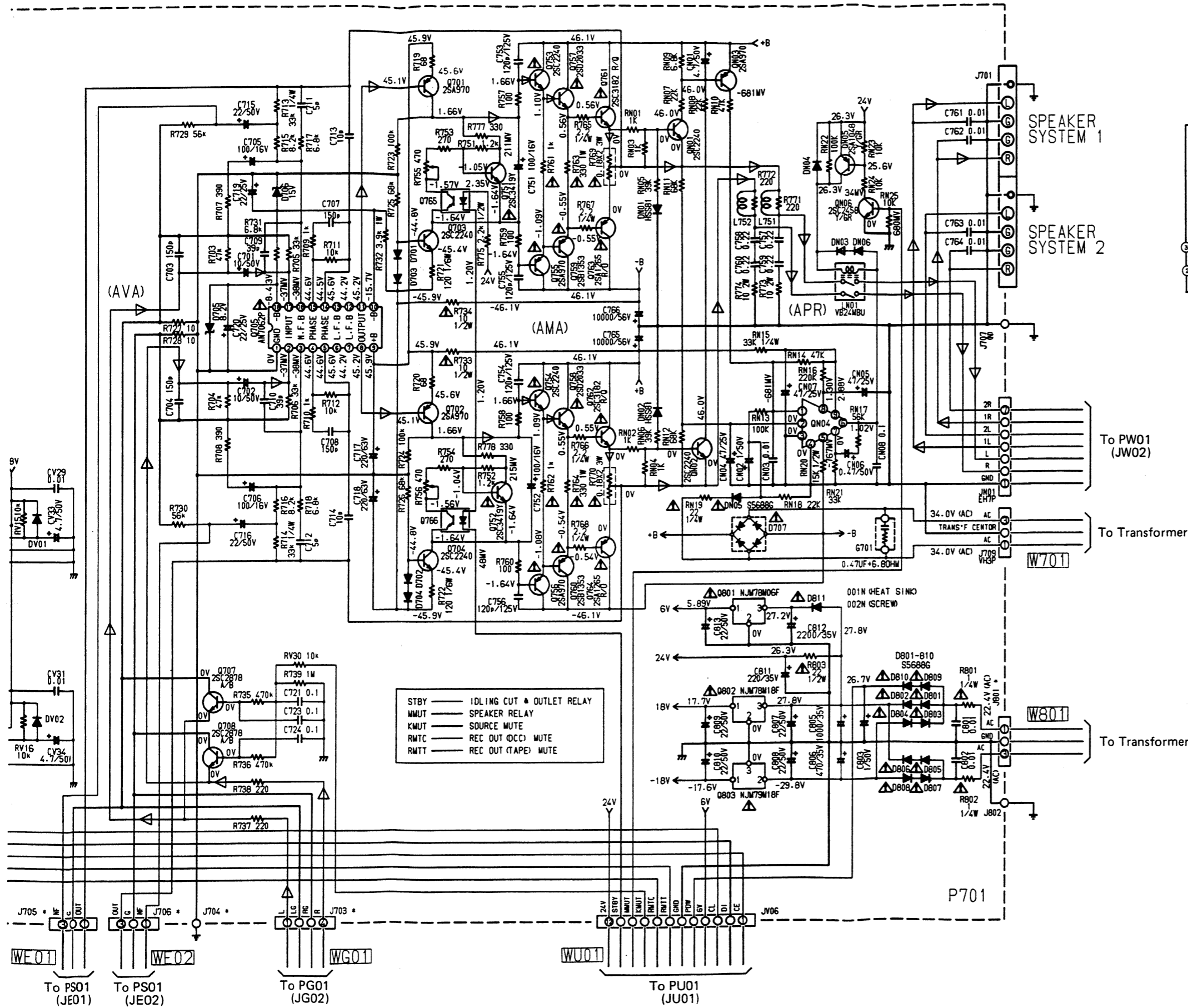

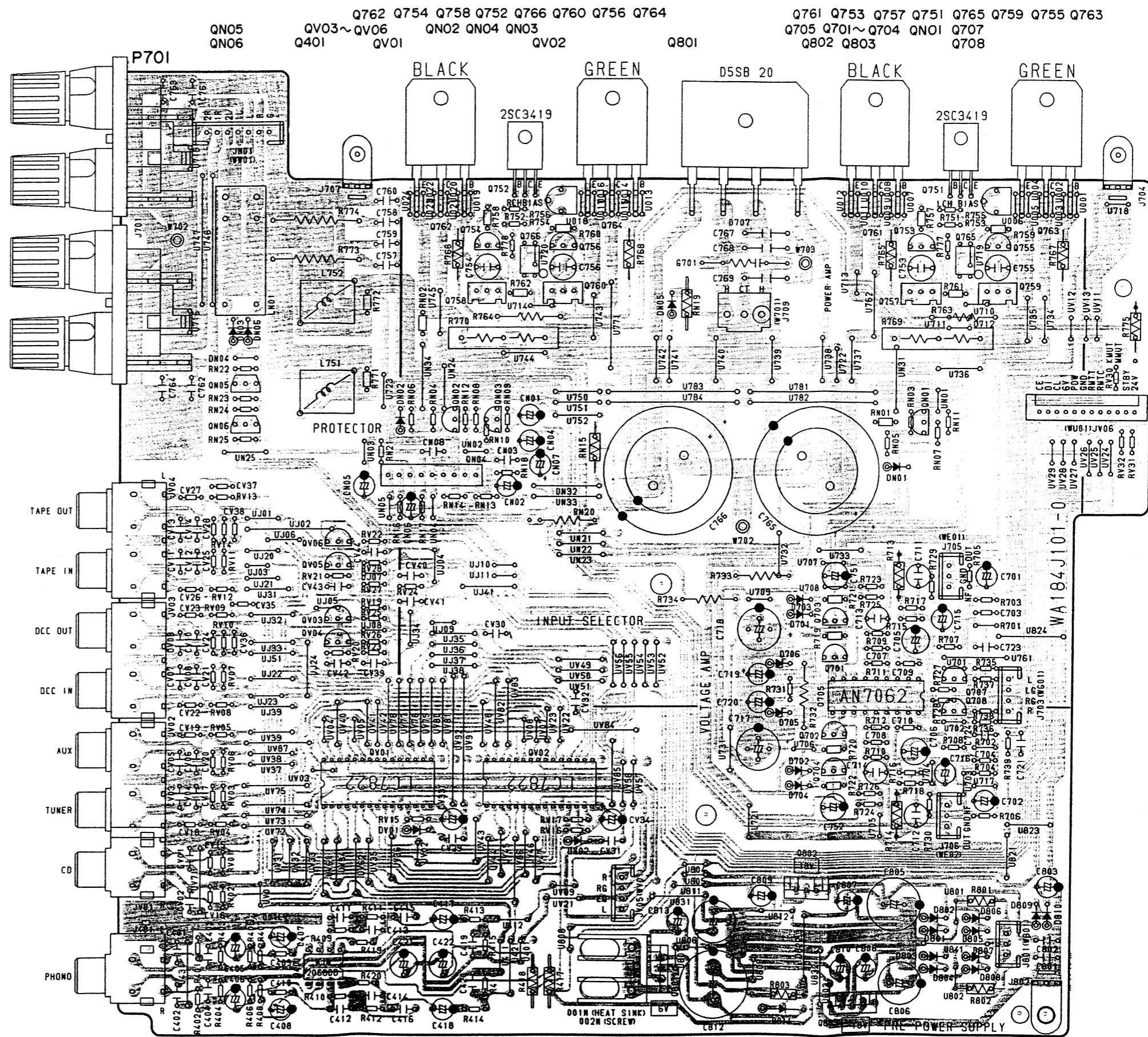

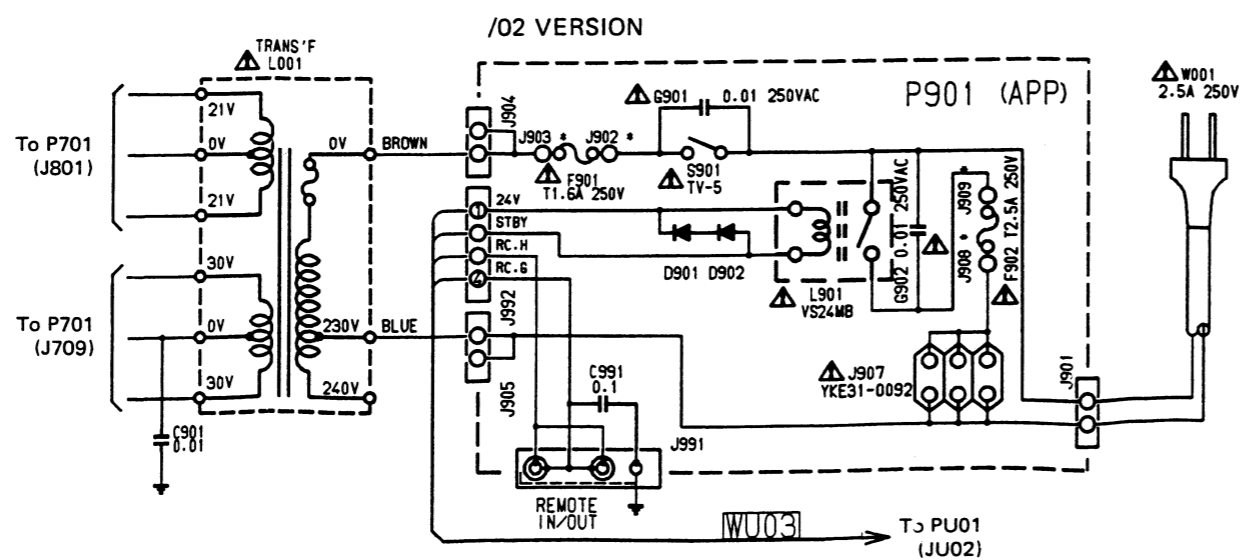
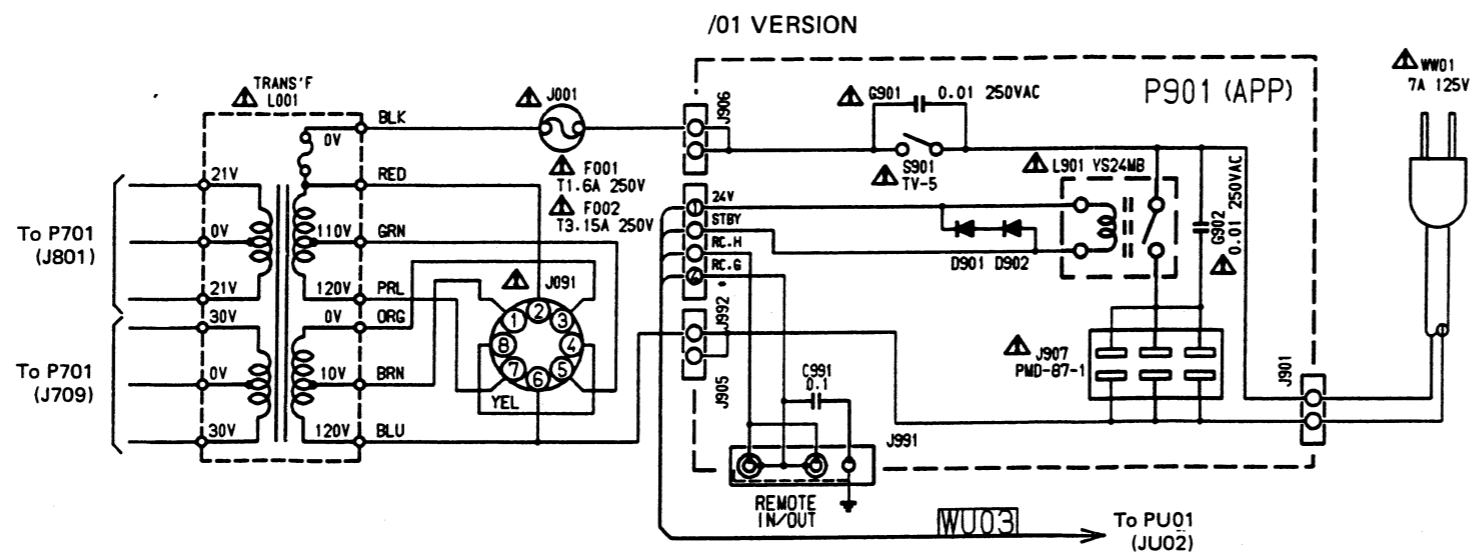
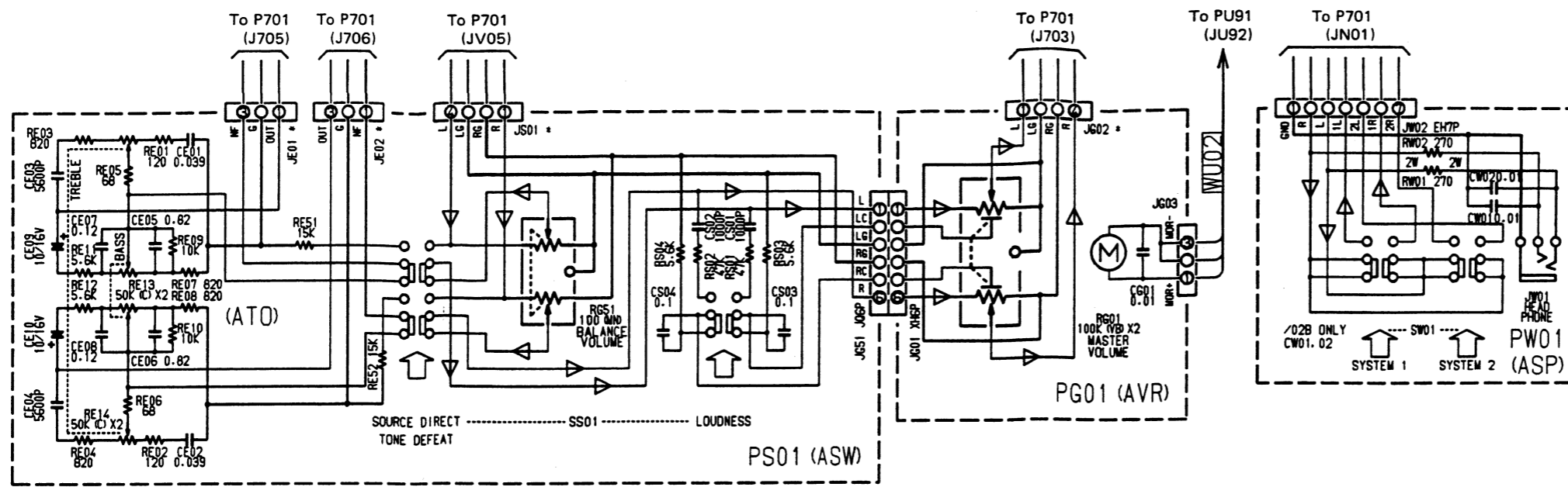

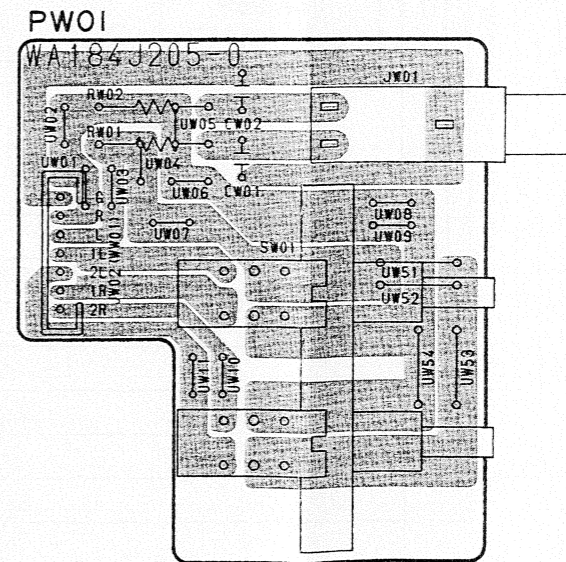
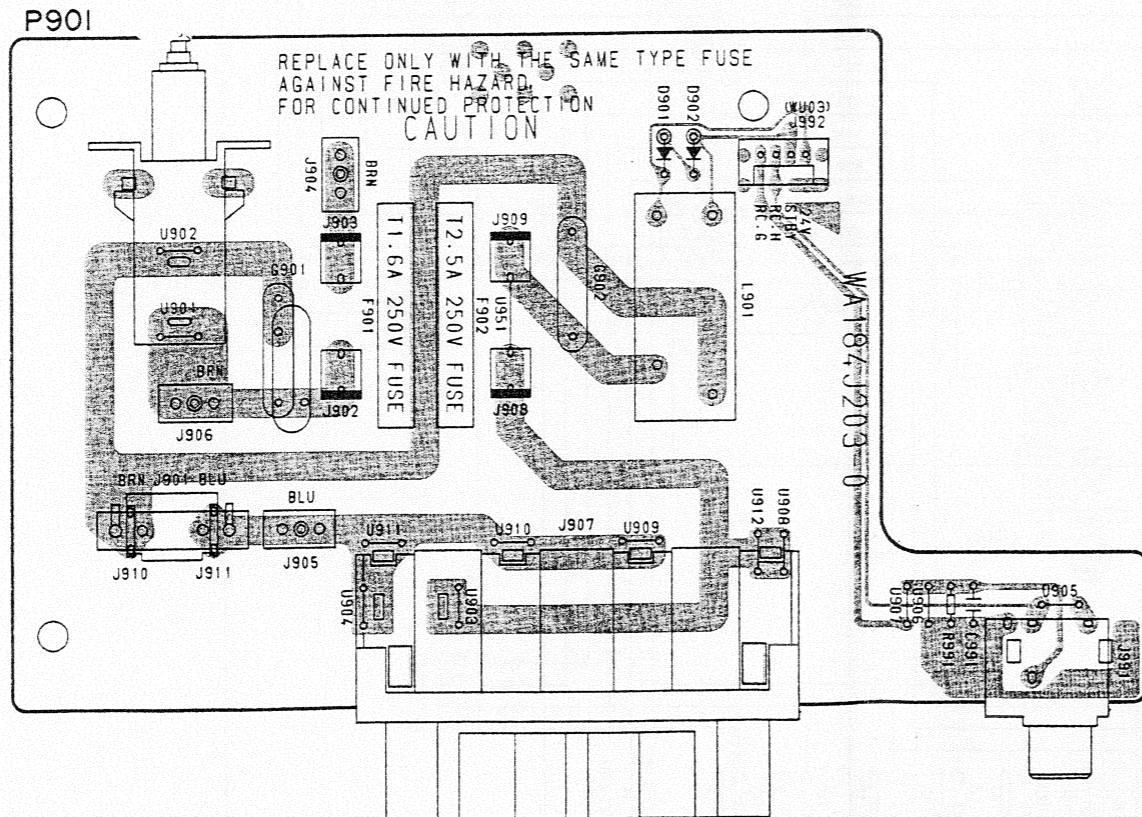
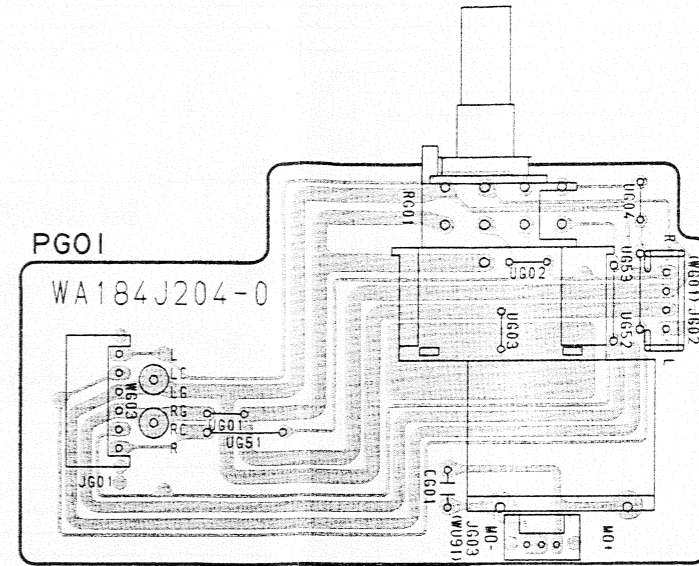
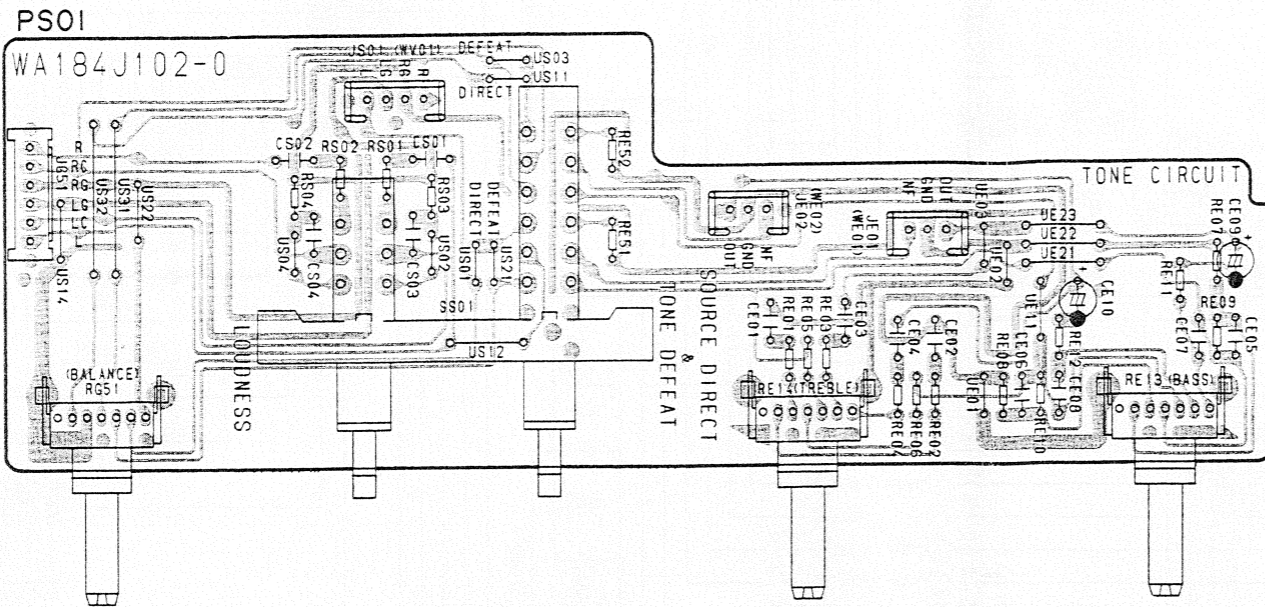

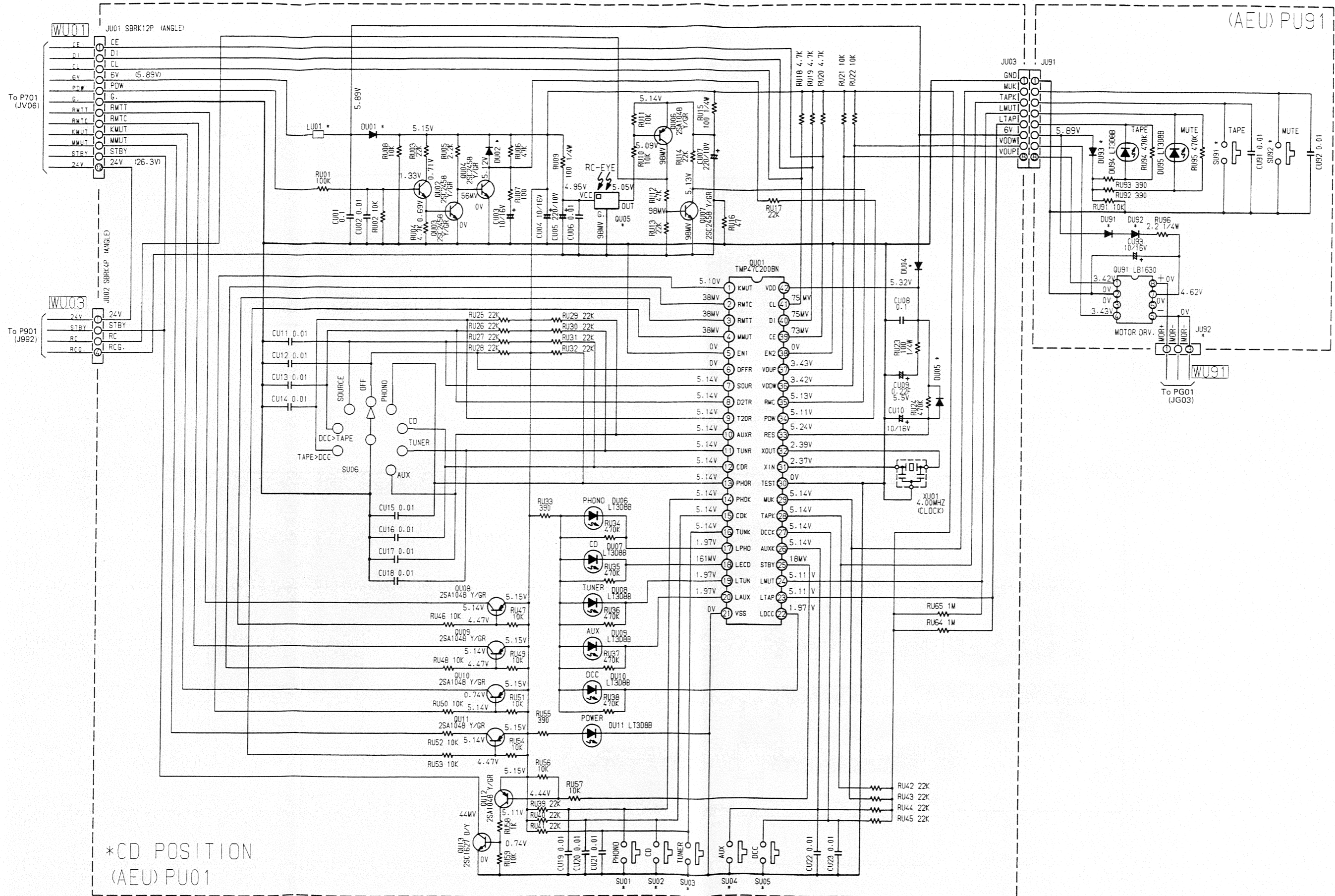

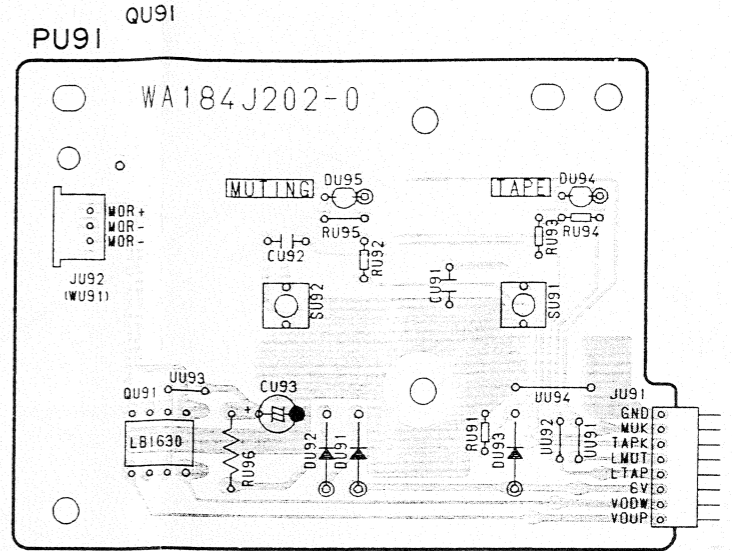
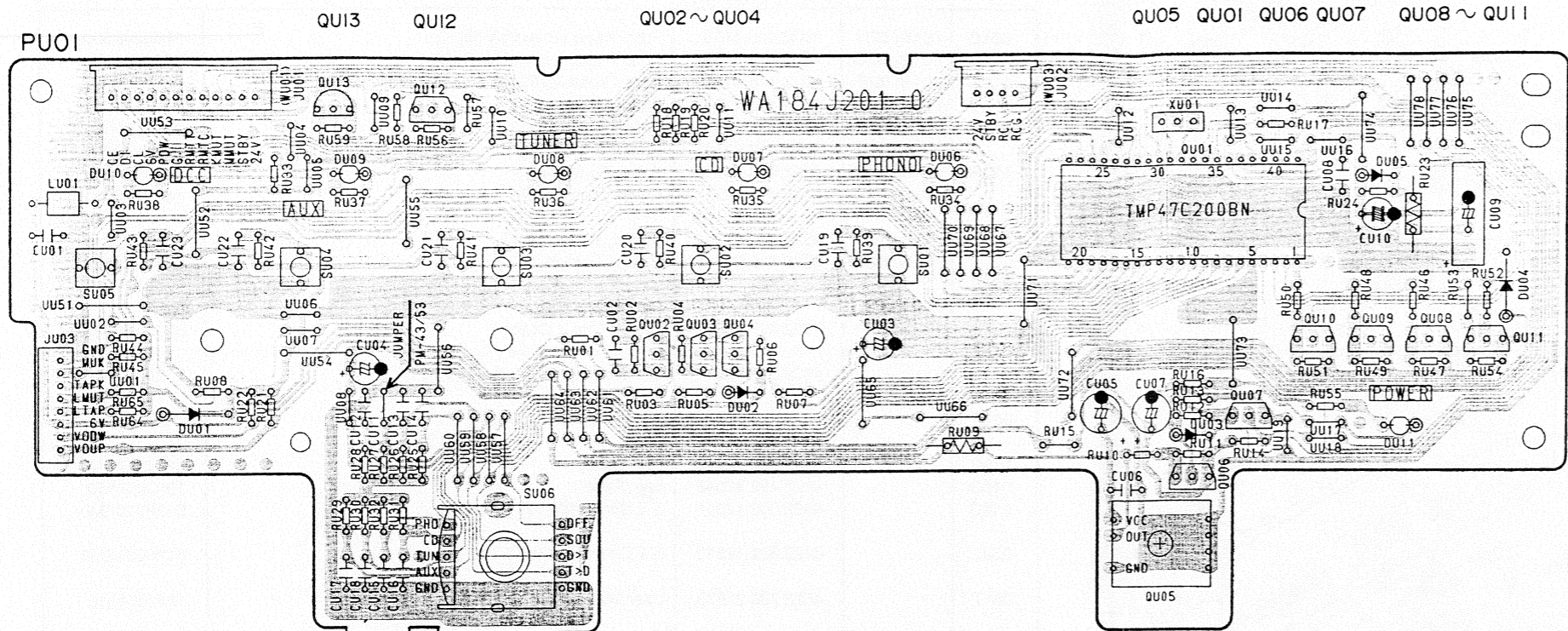

QU01 : TMP47C200BN

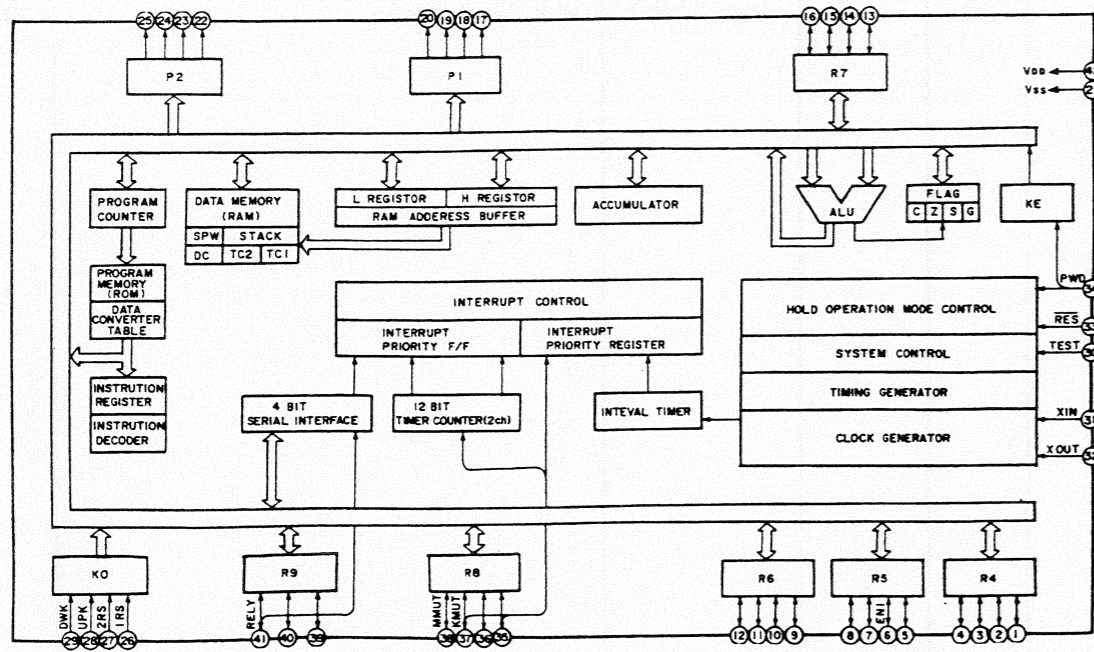

QU91 : LB1630

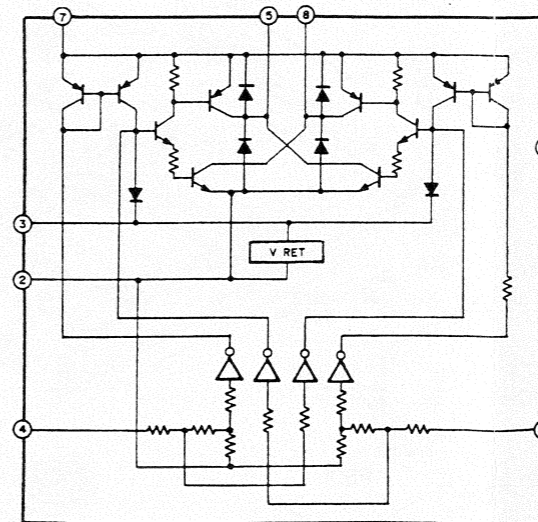

3. EXPLODED VIEW AND PARTS LIST

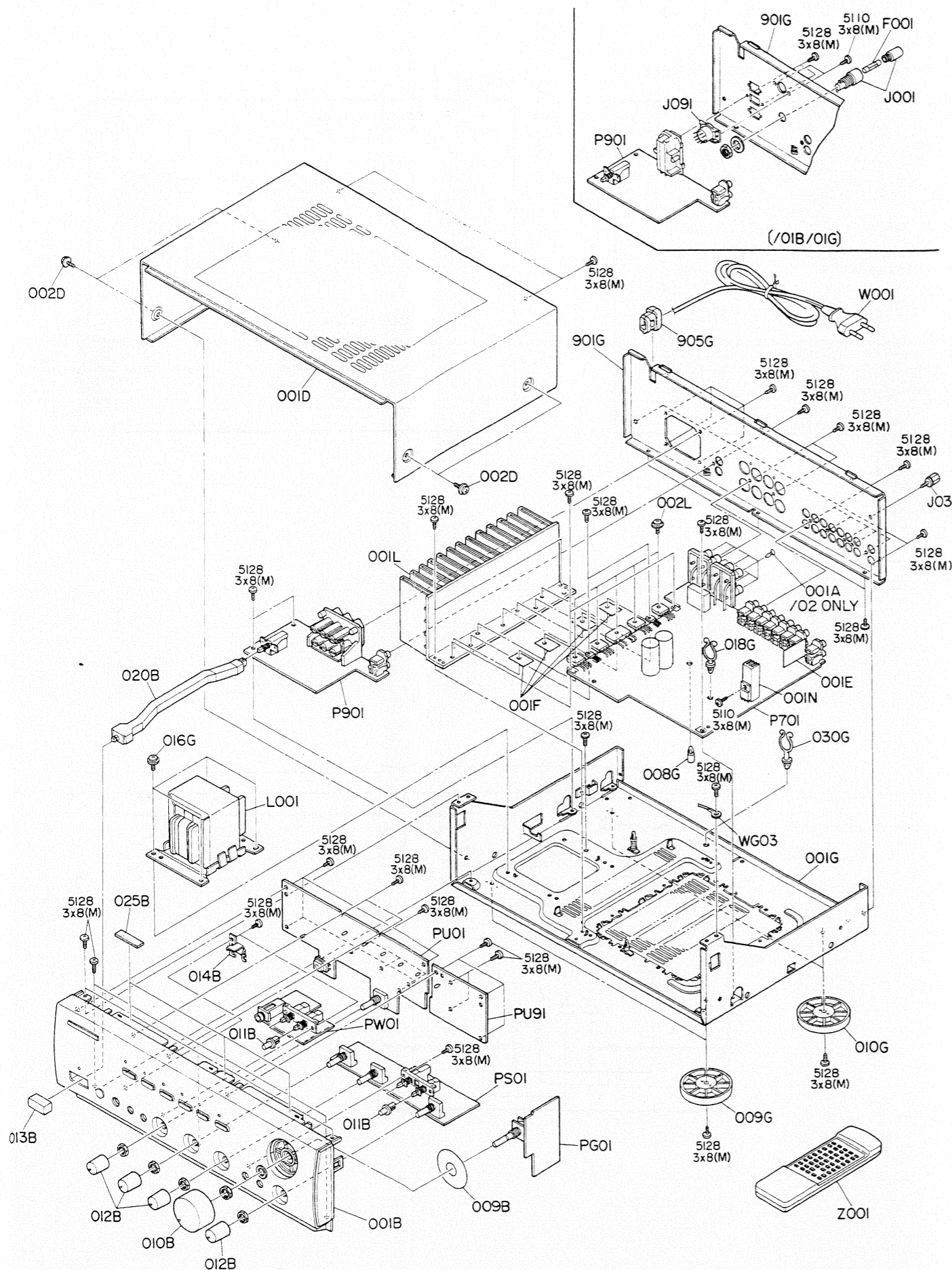

POS.NO	VERSION	PART NO. (FOR EUROPE)	DESCRIPTION	PART NO.
001B	/01B/02B	4822 426 51681	Front Panel Assembly (BLK)	185J248500
	/01G/02G	4822 426 51682	Front Panel Assembly (GLD)	185J248530
010B	/01B/02B	4822 413 41679	Knob, Volume (BLK)	063J154080
	/01G/02G	4822 413 41683	Knob, Volume (GLD)	063J154090
011B	/01B/02B	4822 410 60343	Button, Push (BLK)	058J270030
	/01G/02G	4822 410 62867	Button, Push (GLD)	058J270230
012B	/01B/02B	4822 413 41813	Knob, Tone (BLK)	185J154010
	/01G/02G	4822 413 41814	Knob, Tone (GLD)	185J154020
013B	/01B/02B	4822 410 62744	Button, Power (BLK)	285K270010
	/01G/02G	4822 410 62745	Button, Power (GLD)	285K270110
020B		4822 404 60772	Link, Power SW.	185J121010
001A	/02B/02G	4822 417 20618	Canoe Crip (Cover)	306V259030
002D		4822 502 12511	B.T.Screw (W/W) 3 x 8 (M)	51260308M0
001F		4822 466 62033	Insulator, DENKA Sheet	242H120020
009G		4822 462 42045	Leg, Front	183J057010
010G		4822 462 42048	Leg, Rear	183J057110
016G		4822 502 12511	B.T.Screw (W/ W) 3 x 8 (M)	51260308M0
002L		4822 502 12512	B.T.Screw (W/ W) 3 x 12 (M)	51260312M0
001T		4822 736 21838	User Manual	185J851310
▲ F001	/01B/01G	4822 253 30415	Fuse T1.6A 250V	FS10160850
▲ F002	/01B/01G	4822 070 33152	Fuse T3.15A 250V	FS10315850
▲ J001	/01B/01G	4822 256 30233	Jack, Fuse Holder	YJ08000290
J031		4822 290 40297	Terminal, GND	YL03010280
▲ J091	/01B/01G	4822 272 10327	Voltage Selector	BY05080070
▲ J092	/01B/01G	4822 265 10092	Jack, AC Adapter	YJ04001240
▲ L001	/01B/01G	4822 146 21754	Power Transformer	TS18620150
	/02B/02G	4822 146 21755	Power Transformer	TS18620140
Z001		4822 218 10519	Unit K, Remoto Control	ZK185J0010

4. TEST EQUIPMENT REQUIRED FOR SERVICING

Item	Use
Distortion Analyzer	Distortion measurements
Audio Oscillator	Sinewave and squarewave signal source
ACVTVM	Voltage measurements (AC)
Oscilloscope	Waveform analysis and trouble shooting and ASO alignment
Circuit Tester	Trouble shooting
DCVTVM	Voltage measurements (DC)
AC Wattmeter	Monitors primary power to amplifier
Line Voltmeter	Monitors potential of primary power to amplifier
Variable Autotransformer	Adjust level of primary power to amplifier
Shorting Plug	Shorts amplifier input to eliminate noise pickup

5. IDLING CURRENT ADJUSTMENT

- Before switching the power ON, set the Master Volume control to the minimum position and the Balance and Tone controls to the center positions. Also set semi-fixed resistors R755 (L CH) and R756 (R CH) on PCB P701 to the center positions.
- Each of the cement resistors R769 (L CH) and R770 (R CH) on the PCB P701 is provided with three test points. Connect a digital voltmeter, set for the DC voltage input, to the test points at the two extremities of the three test points of R769 or R770.
- After the setup above, switch the power ON and adjust semi-fixed resistor R755 (L CH) or R756 (R CH) on PCB P701 according to the digital voltmeter reading. The target setting value is 18 mV (50 mA) for both the L CH and R CH.

Please refer to the table below.

Elapsed time after power ON	Idling current setting value
1 min. - 1.5 min.	16 mV
1.5 min. - 2 min.	17.5 mV
2 min. - 3 min.	19 mV
3 min. - 5 min.	20 mV

Note on Safety:

Symbol ▲ Fire or electrical shock hazard. Only original parts should be used to replace any part marked with symbol ▲. Any other component substitution (other than original type), may increase risk of fire or electrical shock hazard.

6. USE OF SERVICE HOLE

- If the use of the service hole is required, remove the cover by cutting 10 bridges (A) using a tool such as a pair of cutter.
- During this work, be careful of the sharp edges at the cut positions.
- After using the service hole, rotate the cover and fix it using screws [3 x 6 (M)].

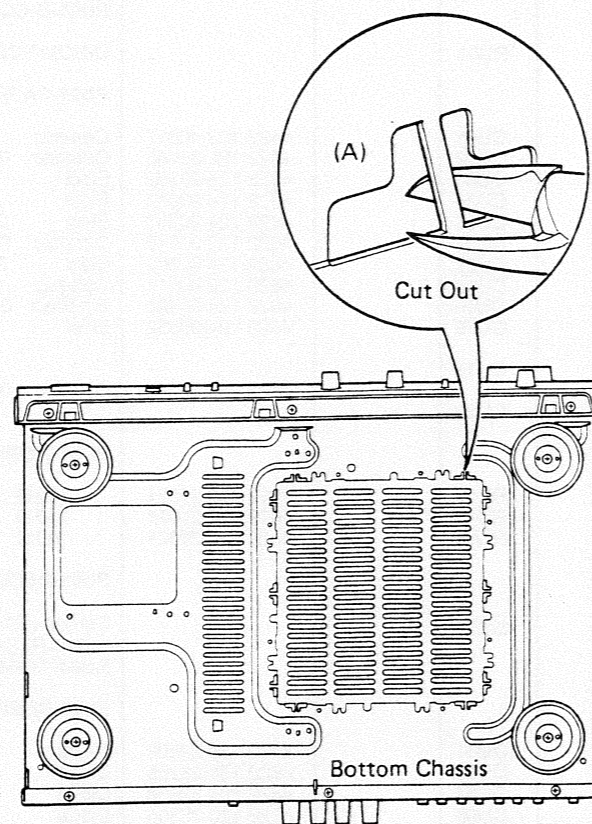

7. VOLTAGE CONVERSION

● EUROPEAN MODEL ONLY (/ 01)

To convert the unit to a different power source voltage, change the position as illustrated in the drawing below.

VOLTAGE SELECTOR

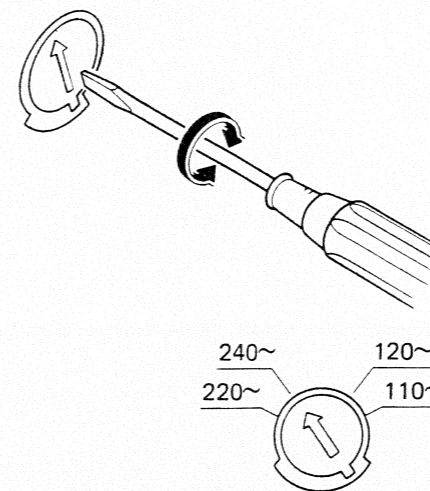

CAUTION
DISCONNECT POWER SUPPLY CORD FROM AC OUTLET BEFORE CONVERTING VOLTAGE.

8. HOW TO CHANGE THE SUPPLY VOLTAGE

(/ 02 Version)

With the 230V rated supply voltage of the / 02 Version can be changed to 240V.

Refer to the following diagram for the voltage change procedure.

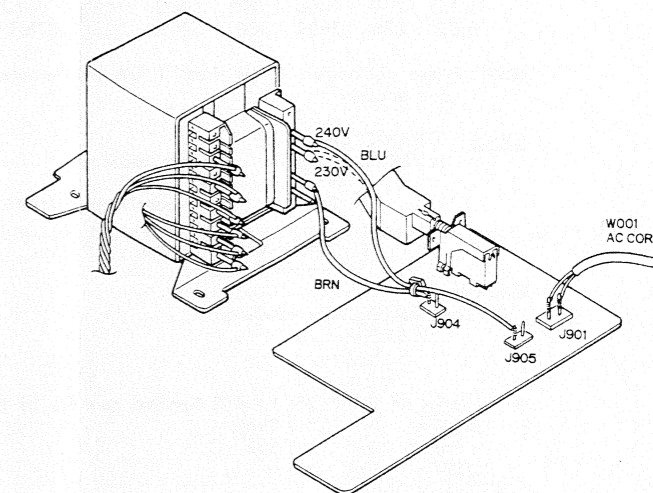

9. MICROPROCESSOR

QU01 : TMP47C200BN

PIN NO.	PORT NAME	I/O	ACT	FUNCTION	PIN NO.	PORT NAME	I/O	ACT	FUNCTION		
1	R40	KMUT	O	L	SOURCE MUTE	22	P20	LDCC	O	L	LED INDICATOR DCC
2	R41	RMTC	O	L	TAPE OUT MUTE FOR DCC	23	P21	LTAP	O	L	LED INDICATOR TAPE
3	R42	RMTT	O	L	TAPE OUT MUTE FOR TAPE	24	P22	LMUT	O	L	LED INDICATOR MUTE
4	R43	MMUT	O	H	SPEAKER OUT MUTE	25	P23	STBY	O	H	STAND-BY OTHER CONTROL
5	R50	EN1	I	-	MODEL SELECT #1	26	K00	AUXK	I	L	KEY INPUT AUX
6	R51	OFFR	I	L	RECORDING OUT OFF	27	K01	DCCK	I	L	KEY INPUT DCC
7	R52	SOUR	I	L	RECORDING OUT SOURCE	28	K02	TAPK	I	L	KEY INPUT TAPE
8	R53	D2TR	I	L	RECORDING OUT COPY DCC→TAPE	29	K03	MUK	I	L	KEY INPUT MANUAL MUTE
9	R60	T2DR	I	L	RECORDING OUT COPY TAPE→DCC	30	TEST	TEST	-	-	NOT USED (GND)
10	R61	AUXR	I	L	RECORDING OUT AUX	31	XIN	XIN	-	-	CLOCK 4.00 MHz
11	R62	TUNR	I	L	RECORDING OUT TUNER	32	XOUT	XOUT	-	-	
12	R63	CDR	I	L	RECORDING OUT CD	33	RESET	RES	I	L	SYSTEM RESET
13	R70	PHOR	I	L	RECORDING OUT PHONO	34	HOLD	POW	I	L	POWER DOWN CHECK
14	R71	PHOK	I	L	KEY INPUT PHONO	35	R80	RMK	I	L	REMOTE CONTROL (RC-5) INPUT
15	R72	CDK	I	L	KEY INPUT CD	36	R81	VODW	O	L	VOLUME CONTROL (DOWN)
16	R73	TUNK	I	L	KEY INPUT TUNER	37	R82	VOUP	O	L	VOLUME CONTROL (UP)
17	P10	LPHO	O	L	LED INDICATOR PHONO	38	R83	EN2	I	-	MODEL SELECT #2
18	P11	LECD	O	L	LED INDICATOR CD	39	R90	CE	O	H	SERIAL OUTPUT (ENABLE)
19	P12	LTUN	O	L	LED INDICATOR TUNER	40	R91	DL	O	H	SERIAL OUTPUT (DATA)
20	P13	LAUX	O	L	LED INDICATOR AUX	41	R92	CL	O	H	SERIAL OUTPUT (CLOCK)
21	VSS	VSS	-	-	GND	42	VDD	VDD	-	-	POWER SUPPLY +5.4V

10. ELECTRICAL PARTS LIST

ASSIGNMENT OF COMMON PARTS CODES.

RESISTOR

R*** : (1) GD05 x x x 140. Carbon film fixed resistor, ± 5 % 1/4W
 R*** : (2) GD05 x x x 160. Carbon film fixed resistor, ± 5 % 1/6W

① — Resistance value

Examples :

① Resistance value

0.1Ω...001	10Ω...100	1kΩ...102	100kΩ...104
0.5Ω...005	18Ω...180	2.7kΩ...272	680kΩ...684
1Ω...010	100Ω...101	10kΩ...103	1MΩ...105
6.8Ω...068	390Ω...391	22kΩ...223	4.7MΩ...475

(Note) Please distinguish 1/4W from 1/6W by the shape of parts used actually.

C*** : CERAMIC CAP.

(1) DD1 x x x x 370. Ceramic capacitor
 Disc type
 Temp.coeff.P350~N1000,50V

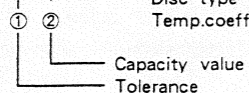

Examples

① Tolerance (Capacity deviation)

- ± 0.25pF ... 0
- ± 0.5pF ... 1
- ± 5% ... 5

* Tolerance of COMMON PARTS handled here are as follows :

- 0.5pF~ 5pF...± 0.25pF
- 6pF~ 10pF...± 0.5pF
- 12pF~ 560pF...± 5%

② Capacity value

0.5pF...005	3pF...030	100pF...101
1pF...010	10pF...100	220pF...221
1.5pF...015	47pF...470	560pF...561

C*** : CERAMIC CAP.

(1) DK16 x x x 300. High dielectric constant ceramic capacitor
 Disc type
 Temp.chara. 2B4, 50V

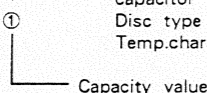

Examples

② Capacity value

100pF...101	1000pF...102	10000pF...103
470pF...471	2200pF...222	

C*** : ELECTROLY CAP. (⚡), FILM CAP. (⚡)

(1) EA x x x x x 10. Electrolytic capacitor
 One-way lead type. Tolerance ± 20 %

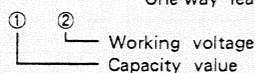

Examples

① Capacity value

0.1μF...104	4.7μF...475	100μF...107
0.33μF...334	10μF...106	330μF...337
1μF...105	22μF...226	1100μF...118
		2200μF...228

② Working voltage

6.3V...006	25V...025
10V...010	35V...035
16V...016	50V...050

(2) DF15 x x x 350. Plastic film capacitor
 One-way type. Mylar ± 5 % 50V

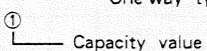

Examples

① Capacity value

0.001μF(1000pF)...102	0.1μF...104
0.0018μF...182	0.56μF...564
0.01μF...103	1μF...105
0.015μF...153	

NOTE : The above CODES (R***, R***, C***, C*** and C***) are omitted on the schematic diagram in some case.

On the occasion, be confirmed the common parts on the parts list.

POS.NO	VERSION	PART NO. (FOR EUROPE)	DESCRIPTION	PART NO.
PG01			PG01-MASTER VOLUME CIRCUIT BOARD	
CG01		4822 122 30043	MASTER VOLUME PCB	WA184J2040
RG01		4822 101 30832	Cermic Cap. 0.01μF +80% -20% 50V	DK18103310
			Variable Resistor 100K Ω (VB) x 2	RY01040230
PS01			PS01-TONE / DIRECT / LOUDNESS / BAL. CIRCUIT BOARD	
			TONE / DIRECT / LOUDNESS / BAL. PCB	WA184J1020
CE09		4822 124 90352	PS01-CAPACITORS	
CE10		4822 124 90352	Elect 10μF 16V	OA10601620
			Elect 10μF 16V	OA10601620
C***			PS01-CAPACITORS (COMMON)	
			Plastic Film Capacitor, ±5% 50V: CE01~CE08, CS01~CS04	
RE13		4822 101 30831	PS01-RESISTORS	
RE14		4822 101 30831	50K Ω (C), Variable Bass	RM05032000
			50K Ω (C), Variable Treble	RM05032000
RG51		4822 101 30828	100K Ω (MN), Variable Balance	RM01041540
R***			PS01-RESISTOR (COMMON)	
			Carbon Film Fixed Resistor, ±5%: RE01~RE12, RE51, RE52, RS01~RS04	
SS01		4822 276 13435	PS01-MISCELLANEOUS	
			Push Switch, Direct / Loudness	SP04020600
PU01			PU01-U-COM CIRCUIT BOARD	
			U-COM PCB	WA184J2010
CU01		4822 122 40617	PU01-CAPACITORS	
CU02		4822 122 30043	Ceramic 0.1μF +80% -20% 50V	DD38104010
CU03		4822 124 90352	Ceramic 0.01μF +80% -20% 50V	DK18103310
CU04		4822 124 90352	Elect 10μF 16V	OA10601620
CU05		4822 124 90363	Elect 10μF 16V	OA10601620
CU06		4822 122 30043	Elect 220μF 10V	OA22701020
CU07		4822 124 90363	Ceramic 0.01μF +80% -20% 50V	DK18103310
CU08		4822 122 40617	Elect 220μF 10V	OA22701020
CU09		4822 124 90406	Ceramic 0.1μF +80% -20% 50V	DD38104010
CU10		4822 124 90352	Big Elect 0.022F 5.5V	EX22300530
			Elect 10μF 16V	OA10601620
CU11				
CU23		4822 122 30043	Ceramic 0.01μF +80% -20% 50V	DK18103310
RU09		4822 050 21021	PU01-RESISTORS	
RU15		4822 050 21021	100 Ω ±5% 1/4W	GG05101140
RU23		4822 050 21021	100 Ω ±5% 1/4W	GG05101140
			100 Ω ±5% 1/4W	GG05101140
R***			PU01-RESISTORS (COMMON)	
			Carbon Film Fixed Resistor, ±5%: RU01~RU08, RU10~RU14, RU16~RU22, RU24~RU59, RU64, RU65	
DU01		4822 130 32508	PU01-SEMICONDUCTORS	
DU02		4822 130 33305	Diode DSF10C / RL103E	HD20003000
DU04		4822 130 32508	Diode 1SS176, etc.	HD20002000
DU05		4822 130 32508	Diode DSF10C / RL103E	HD20003000
DU06		4822 130 33305	Diode 1SS176, etc.	HD20002000
DU11		4822 130 80326	L.E.D. LT3D8B (RED)	HI10062320

POS.NO	VERSION	PART NO. (FOR EUROPE)	DESCRIPTION	PART NO.
QU01		4822 209 32576	Microprocessor TMP47C200BN	HU10085050
QU02		4822 130 60839	Transistor 2SC2458 (Y / GR)	HT324582B0
QU03		4822 130 60839	Transistor 2SC2458 (Y / GR)	HT324582B0
QU04		4822 130 60839	Transistor 2SC2458 (Y / GR)	HT324582B0
QU05		4822 130 82139	Photo Unit PAS-C0618	HW10005550
QU06		4822 130 60107	Transistor 2SA1048 (Y / GR)	HT110482B0
QU07		4822 130 60839	Transistor 2SA1048 (Y / GR)	HT324582B0
QU08				
?		4822 130 60107	Transistor 2SA1048 (Y / GR)	HT110482B0
QU12				
QU13		4822 130 60696	Transistor 2SC1627 (O / Y)	HT316272B0
			PU01-MISCELLANEOUS	
LU01		4822 158 60605	Ferrite Core	FC90050060
SU01		4822 276 20508	Push Switch, Tact	SP01011280
SU05		4822 273 10274	Rotary Switch, Rec Selector	SR01080060
SU06				
XU01		4822 242 72223	Ceramic Resonator 4.00MHz	FQ04004030
			PU91-MOTOR VOL. DRIVE CIRCUIT BOARD	
PU91			MOTOR VOL. DRIVE PCB	WA184J2020
			PU91-CAPACITORS	
CU91		4822 122 30043	Ceramic 0.01 μ F +80% -20% 50V	DK18103310
CU92		4822 122 30043	Ceramic 0.01 μ F +80% -20% 50V	DK18103310
CU93		4822 124 90352	Elect 10 μ F 16V	OA10601620
			PU91-RESISTORS	
RU96		4822 116 60309	2.2 Ω \pm 5% 1/4W, Fusible	NH05022140
			PU91-RESISTORS (COMMON)	
R***			Carbon Film Fixed Resistor, \pm 5%: RU91~RU95	
			PU91-SEMICONDUCTORS	
DU91		4822 130 32508	Diode DSF10C / RL103E	HD20003000
DU92		4822 130 32508	Diode DSF10C / RL103E	HD20003000
DU93		4822 130 32508	Diode DSF10C / RL103E	HD20003000
DU94		4822 130 80326	L.E.D. LT3D8B (RED)	HI10062320
DU95		4822 130 80326	L.E.D. LT3D8B (RED)	HI10062320
QU91		4822 209 73287	IC LB1630	HC10235030
			PU91-MISCELLANEOUS	
SU91		4822 276 20508	Push Switch, Tape	SP01011280
SU92		4822 276 20508	Push Switch, Mute	SP01011280
			PW01-HEADPHONE / SPK 1/2 SW. CIRCUIT BOARD	
PW01			HEADPHONE / SPK 1/2 SW. PCB	WA184J2050
CW01	/ 02B/ 02G	4822 122 30043	Ceramic Cap. 0.01 μ F +80% -20% 50V	DK18103310
CW02	/ 02B/ 02G	4822 122 30043	Ceramic Cap. 0.01 μ F +80% -20% 50V	DK18103310
RW01		4822 116 60455	Resistor 270 Ω \pm 5% 2W Metal	NK05271020
RW02		4822 116 60455	Resistor 270 Ω \pm 5% 2W Metal	NK05271020
JW01	/ 01B/ 02B / 01G/ 02G	4822 267 31274	Jack, Headphone	YJ01003340
		4822 267 31365	Jack, Headphone	YJ01003410
SW01		4822 276 12423	Push Switch, Speaker 1/2	SP02021010

POS.NO	VERSION	PART NO. (FOR EUROPE)	DESCRIPTION	PART NO.
P701			P701-MAIN CIRCUIT BOARD Main PCB	WA184J1010
			P701-CAPACITORS	
CN01		4822 124 22274	Elect 4.7 μ F 50V	OA47505020
CN02		4822 124 41543	Elect 1 μ F 50V	OA10505020
CN04		4822 124 22698	Elect 47 μ F 25V	OA47602520
CN05		4822 124 22698	Elect 47 μ F 25V	OA47602520
CN06		4822 124 22273	Elect 0.47 μ F 50V	OA47405020
CN07		4822 124 22698	Elect 47 μ F 25V	OA47602520
CN08		4822 122 40617	Ceramic 0.1 μ F +80% -20% 50V	DD38104010
CV01				
CV14		4822 122 30043	Ceramic 0.01 μ F +80% -20% 50V	DK18103310
CV15				
CV28	/02B/02G	4822 126 11069	Ceramic 150pF \pm 10% 50V	DA16151110
CV29				
CV32		4822 122 30043	Ceramic 0.01 μ F +80% -20% 50V	DK18103310
CV33		4822 124 22274	Elect 4.7 μ F 50V	OA47505020
CV34		4822 124 22274	Elect 4.7 μ F 50V	OA47505020
CV35				
CV38		4822 126 11127	Ceramic 470pF \pm 10% 50V	DA16471110
CV41				
CV44		4822 122 40617	Ceramic 0.1 μ F +80% -20% 50V	DD38104010
C401		4822 122 30043	Ceramic 0.01 μ F +80% -20% 50V	DK18103310
C402		4822 122 30043	Ceramic 0.01 μ F +80% -20% 50V	DK18103310
C403	/01B/01G	4822 126 11069	Ceramic 150pF \pm 10% 50V	DA16151110
C404	/01B/01G	4822 126 11069	Ceramic 150pF \pm 10% 50V	DA16151110
C405		4822 124 90352	Elect 10 μ F 16V	OA10601620
C406		4822 124 90352	Elect 10 μ F 16V	OA10601620
C407		4822 124 41539	Elect 47 μ F 16V	OA47601620
C408		4822 124 41539	Elect 47 μ F 16V	OA47601620
C409	/02B/02G	4822 126 11127	Ceramic 470pF \pm 10% 50V	DA16471110
C410	/02B/02G	4822 126 11127	Ceramic 470pF \pm 10% 50V	DA16471110
C417		4822 124 90357	Elect 2.2 μ F 50V	OA22505020
C418		4822 124 90357	Elect 2.2 μ F 50V	OA22505020
C421		4822 124 41535	Elect 100 μ F 25V	OA10702520
C422		4822 124 41535	Elect 100 μ F 25V	OA10702520
C701		4822 124 22571	Elect 10 μ F 50V	OA10605020
C702		4822 124 22571	Elect 10 μ F 50V	OA10605020
C703		4822 126 11069	Ceramic 150pF \pm 10% 50V	DA16151110
C704		4822 126 11069	Ceramic 150pF \pm 10% 50V	DA16151110
C705		4822 124 90354	Elect 100 μ F 16V	OA10701620
C706		4822 124 90354	Elect 100 μ F 16V	OA10701620
C707		4822 126 11069	Ceramic 150pF \pm 10% 50V	DA16151110
C708		4822 126 11069	Ceramic 150pF \pm 10% 50V	DA16151110
C709		4822 126 11068	Ceramic 39pF \pm 5% 50V	DA15390110
C710		4822 126 11068	Ceramic 39pF \pm 5% 50V	DA15390110
C711		4822 121 43127	Film 5pF \pm 10% 50V	DF56050090
C712		4822 121 43127	Film 5pF \pm 10% 50V	DF56050090
C713		4822 121 43128	Film 10pF \pm 10% 50V	DF56100090
C714		4822 121 43128	Film 10pF \pm 10% 50V	DF56100090
C715		4822 124 90362	Elect 22 μ F 50V	OA22605020
C716		4822 124 90362	Elect 22 μ F 50V	OA22605020
C717		4822 124 23068	Elect 220 μ F 63V	OA22706320
C718		4822 124 23068	Elect 220 μ F 63V	OA22706320
C719		4822 124 90361	Elect 22 μ F 25V	OA22602520
C720		4822 124 90361	Elect 22 μ F 25V	OA22602520
C721		4822 122 40617	Ceramic 0.1 μ F +80% -20% 50V	DD38104010
C723		4822 122 40617	Ceramic 0.1 μ F +80% -20% 50V	DD38104010
C724		4822 122 40617	Ceramic 0.1 μ F +80% -20% 50V	DD38104010
C751		4822 124 90354	Elect 100 μ F 16V	OA10701620
C752		4822 124 90354	Elect 100 μ F 16V	OA10701620
C753				
CV756		4822 121 50548	Film 120pF \pm 5% 125V	DF55121510
CV761				
CV764	/02B/02G	4822 122 30043	Ceramic 0.01 μ F +80% -20% 50V	DK18103310

POS.NO	VERSION	PART NO. (FOR EUROPE)	DESCRIPTION	PART NO.
▲ C765		4822 124 80692	Elect 1000µF 56V	OB10905610
▲ C766		4822 124 80692	Elect 1000µF 56V	OB10905610
C801		4822 122 30043	Ceramic 0.01µF +80% -20% 50V	DK18103310
C802		4822 122 30043	Ceramic 0.01µF +80% -20% 50V	DK18103310
C803		4822 124 41543	Elect 1µF 50V	OA10505020
C805		4822 124 90356	Elect 1000µF 35V	OA10803520
C806		4822 124 41541	Elect 470µF 35V	OA47703520
C807				
C810		4822 124 90362	Elect 22µF 50V	OA22605020
C811		4822 124 41538	Elect 220µF 35V	OA22703520
C812		4822 124 22695	Elect 2200µF 35V	OA22803520
C813		4822 124 90362	Elect 22µF 50V	OA22605020
G701		4822 121 20263	Component RFD2B474K	BF47400010
C***			P701-CAPACITORS (COMMON) Plastic Film Capacitor, ±10%: CN03, C419, C420 Plastic Film Capacitor, ±5%: CV39, CV40, C411~C416, C757, C758, (C759, C760 [/ 02B/ 02G]) High Dielectric Constant Ceramic Capacitor, 50V: (C403, C404 [/ 02B/ 02G])	
C***				
C***				
RN01		4822 052 10102	1K Ω ±5% 1/6W	GG05102160
RN02		4822 052 10102	1K Ω ±5% 1/6W	GG05102160
RN15		4822 050 23303	33K Ω ±5% 1/4W	GG05333140
▲ RN19		4822 113 90119	22 Ω ±2% 1/4W, Fusible	NF02220140
RN20		4822 050 21503	15K Ω ±5% 1/2W	GG05153120
▲ R417		4822 116 90119	22 Ω ±2% 1/4W, Fusible	NF02220140
▲ R418		4822 116 90119	22 Ω ±2% 1/4W, Fusible	NF02220140
R713		4822 050 23303	33K Ω ±5% 1/4W	GG05333140
R714		4822 050 23303	33K Ω ±5% 1/4W	GG05333140
R719	/ 02B/ 02G	4822 050 26809	68 Ω ±5% 1/6W	GG05680160
R720	/ 02B/ 02G	4822 050 26809	68 Ω ±5% 1/6W	GG05680160
R721	/ 02B/ 02G	4822 117 10159	120 Ω ±5% 1/6W	GG05121160
R722	/ 02B/ 02G	4822 117 10159	120 Ω ±5% 1/6W	GG05121160
R732		4822 116 51137	3.9K Ω ±5% 1W	GA05392010
▲ R733		4822 116 60313	10 Ω ±5% 1/2W, Fusible	NH05100120
▲ R734		4822 116 60313	10 Ω ±5% 1/2W, Fusible	NH05100120
R755		4822 100 11426	470 Ω, Trimming	RA04710780
R756		4822 100 11426	470 Ω, Trimming	RA04710780
R757		4822 052 10101	100 Ω ±5% 1/6W	GG05101160
R760				
R761		4822 052 10102	1K Ω ±5% 1/6W	GG05102160
R762		4822 052 10102	1K Ω ±5% 1/6W	GG05102160
R763		4822 053 10331	330 Ω ±5% 1W	GA05331010
R764		4822 053 10331	330 Ω ±5% 1W	GA05331010
R765		4822 116 83963	2.2 Ω ±5% 1/4W	GG05022140
R768				
R769		4822 116 82049	0.18 Ω x 2 3W	BZ10182010
R770		4822 116 82049	0.18 Ω x 2 3W	BZ10182010
R771		4822 052 10221	220 Ω ±5% 1/6W	GG05221160
R772		4822 052 10221	220 Ω ±5% 1/6W	GG05221160
R773		4822 053 11109	10 Ω ±5% 2W	GA05100020
R774		4822 053 11109	10 Ω ±5% 2W	GA05100020
R775		4822 117 10002	2.2K Ω ±5% 1/2W	GG05222120
▲ R801		4822 117 10158	1 Ω ±5% 1/4W	GG05010140
▲ R802		4822 117 10158	1 Ω ±5% 1/4W	GG05010140
▲ R803		4822 116 80653	22 Ω ±5% 1/2W, Fusible	NH05220120

POS.NO	VERSION	PART NO. (FOR EUROPE)	DESCRIPTION	PART NO.
<u>R***</u>			P701-RESISTORS (COMMON) Carbon Film Fixed Resistor, ±5%: RN03~RN14, RN16~RN18, RN21~RN25, RV01~RV17, RV19~RV28, RV30~RV32, R401~R416, R419, R420, R703~R712, R715~R718, (R719~R722 (/01B/ 01G)) R723~R731, R735~R739, R751~R754, R777, R778	
			P701-SEMICONDUCTORS	
DN01		4822 130 80837	Diode HSS81	HD20027010
DN02		4822 130 80837	Diode HSS81	HD20027010
DN03		4822 130 33305	Diode 1SS176, etc.	HD20002000
DN04		4822 130 33305	Diode 1SS176, etc.	HD20002000
DN05		4822 130 80839	Diode S5688G	HD20029050
DN06		4822 130 33305	Diode 1SS176, etc.	HD20002000
DV01		4822 130 33305	Diode 1SS176, etc.	HD20002000
DV02		4822 130 33305	Diode 1SS176, etc.	HD20002000
D701		4822 130 33305	Diode 1SS176, etc.	HD20002000
D704		4822 130 80273	Zener NTJ8.2C	HD30821000
D705		4822 130 80322	Zener NTJ15B	HD31501000
D706		4822 130 83438	Diode D5SB-20 5A 200V	HE20016290
▲D707		4822 130 83438	Diode D5SB-20 5A 200V	HE20016290
▲D801	/02B/ 02G	4822 130 80839	Diode S5688G	HD20029050
▲D802	/02B/ 02G	4822 130 80839	Diode S5688G	HD20029050
▲D803	/02B/ 02G	4822 130 80839	Diode S5688G	HD20029050
▲D804	/02B/ 02G	4822 130 80839	Diode S5688G	HD20029050
▲D805	/02B/ 02G	4822 130 80839	Diode S5688G	HD20029050
▲D806	/02B/ 02G	4822 130 80839	Diode S5688G	HD20029050
▲D807	/02B/ 02G	4822 130 80839	Diode S5688G	HD20029050
▲D808	/02B/ 02G	4822 130 80839	Diode S5688G	HD20029050
▲D809	/02B/ 02G	4822 130 80839	Diode S5688G	HD20029050
▲D810	/02B/ 02G	4822 130 80839	Diode S5688G	HD20029050
D811		4822 130 32508	Diode RL103E /DSF10C	HD20003000
QN01		4822 130 43233	Transistor 2SC2240 (GR / BL)	HT322402A0
QN02		4822 130 43233	Transistor 2SC2240 (GR / BL)	HT322402A0
QN03		4822 130 42951	Transistor 2SA970 (GR / BL)	HT109702A0
QN04		4822 209 83312	IC TA7317P	HC10042050
QN05		4822 130 60107	Transistor 2SA1048 (Y / GR)	HT110482B0
QN06		4822 130 60839	Transistor 2SC2458 (Y / GR)	HT324582B0
QV01		4822 209 32553	IC LC7822N	HC10309030
QV02		4822 209 32553	IC LC7822N	HC10309030
QV03		4822 130 43819	Transistor 2SC2878 (A / B)	HT328782A0
QV06		4822 130 43819	Transistor 2SC2878 (A / B)	HT328782A0
Q401		4822 209 73064	IC NJM2068DD	HC10053090
Q701		4822 130 42951	Transistor 2SA970 (GR / BL)	HT109702A0
Q702		4822 130 42951	Transistor 2SA970 (GR / BL)	HT109702A0
Q703		4822 130 43233	Transistor 2SC2240 (GR / BL)	HT322402A0
Q704		4822 130 43233	Transistor 2SC2240 (GR / BL)	HT322402A0
Q705		4822 209 83732	IC AN7062	HC10066020
Q707		4822 130 43819	Transistor 2SC2878 (A / B)	HT328782A0
Q708		4822 130 43819	Transistor 2SC2878 (A / B)	HT328782A0
Q751		4822 130 60117	Transistor 2SC3419 (Y)	HT334191Y0
Q752		4822 130 60117	Transistor 2SC3419 (Y)	HT334191Y0
Q753		4822 130 43233	Transistor 2SC2240 (GR / BL)	HT322402A0
Q754		4822 130 43233	Transistor 2SC2240 (GR / BL)	HT322402A0
Q755		4822 130 42951	Transistor 2SA970 (GR / BL)	HT109702A0
Q756		4822 130 42951	Transistor 2SA970 (GR / BL)	HT109702A0
▲Q757		4822 130 62335	Transistor 2SD2033	HT420331E0
▲Q758		4822 130 62335	Transistor 2SD2033	HT420331E0
▲Q759		4822 130 62334	Transistor 2SB1353	HT213531E0
▲Q760		4822 130 62334	Transistor 2SB1353	HT213531E0
▲Q761		4822 130 43306	Transistor 2SC3182 (R / O)	HT331822A0
▲Q762		4822 130 43306	Transistor 2SC3182 (R / O)	HT331822A0
▲Q763		4822 130 43019	Transistor 2SA1265 (R / O)	HT112652A0
▲Q764		4822 130 43019	Transistor 2SA1265 (R / O)	HT112652A0
Q765		4822 130 90347	Photo Unit PC-817	HW10006320
Q766		4822 130 90347	Photo Unit PC-817	HW10006320

POS.NO	VERSION	PART NO. (FOR EUROPE)	DESCRIPTION	PART NO.
▲ Q801		4822 209 62423	IC 78M06F	HC3850609F
▲ Q802		4822 209 80675	IC 78M18F	HC3851809F
▲ Q803		4822 209 31788	IC 79M18F	HC3951809F
			P701-MISCELLANEOUS	
JV01		4822 290 81598	Terminal, 2P RCA	YT02021130
JV02		4822 290 81603	Terminal, 4P RCA	YT02041030
JV03		4822 290 81603	Terminal, 4P RCA	YT02041030
JV04		4822 290 81603	Terminal, 4P RCA	YT02041030
J401		4822 290 81598	Terminal, 2P RCA	YT02021130
J701		4822 290 61179	Terminal, Speaker	YT01080120
▲ LN01		4822 280 70354	Relay VB24MBU	LY20240310
L751		4822 157 63085	Air Coil, SPK	ML08010010
L752		4822 157 63085	Air Coil, SPK	ML08010010
			P901-POWER SW. / AC FUSE CIRCUIT BOARD	
P901			POWER SW. / AC FUSE PCB	WA184J2030
			P901-CAPACITORS	
C901	/02B/02G	4822 122 30043	Ceramic 0.01 μ F +80% -20% 50V	DK18103310
C991		4822 122 40617	Ceramic 0.1 μ F +80% -20% 50V	DD38104010
▲ G901		4822 121 43732	Film 0.01 μ F \pm 20% 250V AC	DF77103500
▲ G902		4822 121 43732	Film 0.01 μ F \pm 20% 250V AC	DF77103500
			P901-SEMICONDUCTORS	
D901		4822 130 33305	Diode 1SS176, etc.	HD20002000
D902		4822 130 33305	Diode 1SS176, etc.	HD20002000
			P901-MISCELLANEOUS	
▲ F901	/02B/02G	4822 253 30415	Fuse T1.6A 250V	FS10160850
▲ F902	/02B/02G	4822 253 40166	Fuse T2.5A 250V	FS10250850
▲ J907	/01B/01G /02B/02G	4822 267 40815	Jack, AC Outlet 3P	YJ04001470
		4822 265 31056	Jack, AC Outlet 3P	YJ04001740
J991		4822 267 41009	Terminal, 2P RCA	YT02020890
▲ L901		4822 280 20517	Relay V524MBU	LY10240190
▲ S901		4822 276 12924	Push Switch, Power	SP01011540

NOTE ON SAFETY:

Symbol ▲ Fire or electrical shock hazard. Only original parts should be used to replace any part marked with symbol ▲. Any other component substitution (other than original type), may increase risk of fire or electrical shock hazard.