

MX673

4822 725 50807

TUNER:ST673/ST673L / AMP: PM673 / CASSETTE DECK: SD873



marantz®

model MX673

System Component

MARANTZ DESIGN AND SERVICE

Using superior design and selected high grade components, MARANTZ company has created the ultimate in stereo sound.

Only **original MARANTZ parts** can insure that your MARANTZ product will continue to perform to the specifications for which it is famous.

Parts for your MARANTZ equipment are generally available to our National Marantz Subsidiary or Agent.

ORDERING PARTS:

Parts can be ordered either by mail or by telex. In both cases, correct part number has to be specified. The following information must be supplied to eliminate delays in processing your order:

1. Complete address
2. Complete part numbers and quantities required
3. Description of parts
4. Model number for which part is required
5. Way of shipment
6. Signature: any order form or telex must be signed otherwise such part order will be considered as null and void.

MARANTZ INTERNATIONAL
Vestdijk 9
5600 MD Eindhoven
The Netherlands
Phone: +31/40.758290
Telefax: +31/40.75.82.99
Telex: 35000 PHTC NL routing IND NLMTFAT

PARTS ORDERING

Parts may be ordered at the following addresses:

AUSTRIA
MARANTZ
Hietzinger Kai 137a
1130 Wien

BELGIUM
SVD DIVISION MARANTZ
Industrialaan 1
1720 Groot-Bijgaarden
Belgium
Telex: 24466

CHILE
MARANTZ
DIVISION OF PHILIPS S.A.
AV. Santa Maria, 0760
Casilla 2687
Santiago
Telex: 240.239

DENMARK
MARANTZ
Horsvinget 5
2630 Tastrup

NORWAY
MARANTZ
Postboks 7034
Assiden
3007 Drammen

FRANCE
MARANTZ FRANCE
4 Rue Bernard Palissy
92600 Asnières
France
Telex: 611651

GERMANY
MARANTZ GERMANY GmbH
Alexanderstrasse 1
2000 Hamburg
Germany

THE NETHERLANDS
Elpro Marantz
Wint Hontlaan 28
3526 KV Utrecht
The Netherlands
Telex: 4748

SWEDEN
MARANTZ
Box 1324
171 25 Solna

FINLAND
MARANTZ
Kuortanegatan 1
00520 Helsingfors 52

GREAT BRITAIN
MARANTZ HiFi U.K. Ltd
Kingsbridge House
Padbury oaks
575-583 Bath Road
Long ford
Middlesex UB7 0EH
Faxnr.: 0753 680 428

GREECE
SHERTON ELECTRONICS S.A.
P.O.Box 21025
Hippocrates Street 188
Athens 11471
Greece
Telex: 216.795

JAPAN
MARANTZ JAPAN, Inc.
35-1, 7-chome, Sagamiono
Sagamihara-shi, Kanagawa
Japan

KUWAIT
AL ALAMIAH ELECTRONICS
Ussama Building
Fahd al Saleem Street
P.O.Box 23781
Safat-Kuwait
Telex: 22694

ITALY
MARANTZ ITALIANA S.P.A.
Via Chiase, 74
20126 Milano
Italy

SAUDI ARABIA
AL ALAMIAH ELECTRONICS
P.O.Box 5954
University Street
Riyadh 11432
Saudi Arabia
Telex: 401530

SOUTH AFRICA
MARANTZ
DIVISION OF PHILIPS S.A.
Main Road Martindale
P.O. Box. 58088
Newville 21114
South Africa

SPAIN
Euroservice S.A.
Bernardo obrégón, 26
28012 Madrid
faxnr.: 3412 306 198

SWITZERLAND
MARANTZ
Technischer Service
Duenstrasse 3
3188 Dürdingen
Switzerland

TURKEY
DOGRUOL Ltd.
I.M.C.
6 Blok N°6310
Unkapani
Istanbul
Turkey
Telex: 22085

MALTA
CACHIA & GALEA
Republic Street, 68D
Valletta
Telex: 1682

PORTUGAL
MARANTZ
Divisao philips S.A. service
Oturela-carnaxide
2795 LINDA-A-VELHA
Telex: 43906

All of the above locations are fully equipped to take care of your total service needs. Because various countries have differing configuration requirements, it is necessary that you contact the service facility in your particular country. In the event that there is no service location listed for your country, please, contact the nearest facility for the necessary assistance.

In case of difficulties, do not hesitate to contact the Technical Department at abovementioned address.

TABLE OF CONTENTS

SECTION	PAGE
AMPLIFIER SECTION	
1. TEST EQUIPMENT REQUIRED FOR SERVICING	1
2. P.W. BOARDS	1
3. ADJUSTMENT PROCEDURES	1
4. CIRCUIT DESCRIPTION	2
5. BLOCK DIAGRAM	10
6. SCHEMATIC DIAGRAM	12
7. WIRING DIAGRAM	28
8. COMPONENT LOCATIONS	30
9. EXPLODED VIEW AND PARTS LIST	36
10. ELECTRICAL PARTS LIST	40
TUNER SECTION	
1. TEST EQUIPMENT REQUIRED FOR SERVICING	47
2. P.W. BOARDS	47
3. TUNER ALIGNMENT PROCEDURES	48
4. TEST POINT AND ALIGNMENT POINTS	49
5. ONE-CHIP MICROPROCESSOR FOR TUNER-LC6514B-3357 (Q505)	50
6. BLOCK DIAGRAM	53
7. SCHEMATIC DIAGRAM	54
8. COMPONENT LOCATIONS	50
9. EXPLODED VIEW AND PARTS LIST	62
10. ELECTRICAL PARTS LIST	64
DECK SECTION	
1. P.W. BOARDS	66
2. TEST EQUIPMENT REQUIRED FOR SERVICING	66
3. OPERATIONAL DESCRIPTIONS OF AUDIO AND PERIPHERAL CIRCUITS	67
4. OPERATIONAL DESCRIPTION OF MICROPROCESSOR AND ITS PERIPHERAL CIRCUITS	69
5. MOTOR DRIVE CIRCUIT	71
6. OTHER INPUTS AND OUTPUTS	72
7. SINGLE-CHIP 4-BIT MICROCOMPUTER FOR LM6413E (QU11/QU31) N-CHANNEL E/D MOS LSI	73
8. MECHANISM OPERATIONAL DESCRIPTION	78
9. DISASSEMBLY	79
10. ELECTRICAL ADJUSTMENTS	80
11. LEVEL DIAGRAMS	84
12. WIRING DIAGRAM	86
13. SCHEMATIC DIAGRAM	88
14. PARTS LOCATIONS	94
15. EXPLODED VIEW AND PARTS LIST	97
16. ELECTRICAL PARTS LIST	103
TECHNICAL SPECIFICATIONS	107

How to use this service manual

- The "Common parts" which Marantz Japan, Inc. has established are eliminated from this service manual.
- These "Common parts" are applied to all models in the service manuals arranged and issued by MJI.
- To indicate clearly the common parts in the schematic diagram, a line is drawn above or under the Ref. Desig. No. of applicable parts.
- "Common parts" can be supplied from the Marantz service center as ever.
In case of ordering, please establish the parts number of 12 N/C'S following the procedure mentioned in this service manual "How to establish the parts number for common parts".

(NOTE)

When you order parts to the Marantz parts center, please take notice of the following points.

- 1) Please correctly write the parts number of 12 N/C'S following the rule.
- 2) Since ordering parts by the Ref. Desig. No. or ratings indicated in the schematic diagram does not satisfy the above conditions, the Marantz parts supply system does not work properly.
As this case is apt to cause a trouble, please pay attention to it.

AMPLIFIER SECTION

1. TEST EQUIPMENT REQUIRED FOR SERVICING

This table lists the test equipment required for servicing the Stereo Amplifier.

Item	Use
Distortion Analyzer	Distortion measurements
Audio Oscillator	Sinewave and squarewave signal source
AC VTVM	Voltage measurements (AC)
Oscilloscope	Waveform analysis and trouble shooting and ASO alignment
Circuit Tester	Trouble shooting
DC VTVM	Voltage measurements (DC)
AC Wattmeter	Monitors primary power to amplifier
Line Voltmeter	Monitors potential of primary power to amplifier
Variable Autotransformer (0 ~ 140V AC, 10A)	Adjust level of primary power to amplifier
Shorting Plug	Shorts amplifier input to eliminate noise pickup

2. P.W. BOARDS

As can be seen from the circuit diagram the chassis of Model PM673 consists of the following units. Each unit mounted on a printed circuit board is described within the square enclosed by a bold dotted line on the circuit diagram.

1. Relay mounted on P.W. Board PA14
2. Connector mounted on P.W. Board PJ14
3. Video Amp. mounted on P.W. Board PL04
4. Pin Jack Switch mounted on P.W. Board PL14
5. R.G.B. Connector mounted on P.W. Board PL24
6. Selector mounted on P.W. Board PS04
7. Rec Selector mounted on P.W. Board PS34
8. Speaker Switch mounted on P.W. Board PS44
9. Function 1 mounted on P.W. Board PS84
10. Function 3 Switch. mounted on P.W. Board PS94
11. Transf. Wire mounted on P.W. Board PT24
12. U-CON FL Driver mounted on P.W. Board PU04
13. F.I.P. mounted on P.W. Board PU14
14. Tact Switch mounted on P.W. Board PU24
15. U-COM 2 mounted on P.W. Board PU54
16. Speaker Terminal mounted on P.W. Board PW04
17. Dolby Surround mounted on P.W. Board P604
18. Power Amp. Driver mounted on P.W. Board P704
19. TR. L ch mounted on P.W. Board P714
20. TR. R ch mounted on P.W. Board P724
21. TR. Dolby mounted on P.W. Board P734
22. Power Amp./Supply mounted on P.W. Board P754

3. ADJUSTMENT PROCEDURES

- **Adjustment of Main Amp Idling Current**
Connect a digital voltmeter to the R755, R756, and R776 emitter resistor adjustment terminals, turn the power on, then adjust variable resistors R711, R712, and R731 when the power becomes stable so that the reading on the voltmeter is between 1 mV and 1.5 mV.
- **Adjustment of Dolby Surround Output Distortion**
Input 1 kHz to the L or R input terminals, set the mode switch to Dolby Surround, increase the input for a voltage of 1.6 V at the test point (J601), then adjust variable resistor R630 so that the distortion is minimum.

4. CIRCUIT DESCRIPTION

1. μ PD75208 (QU01) 64-pin plastic shrink DIP microprocessor

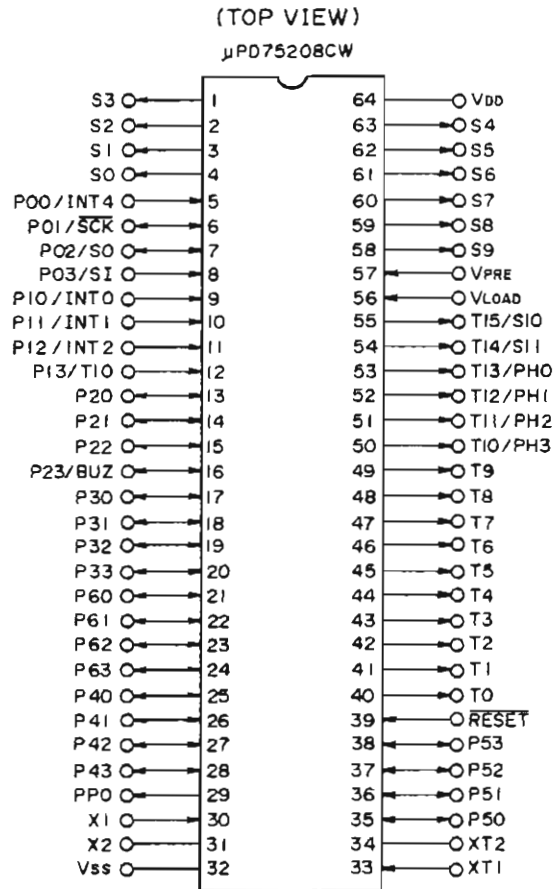

P00 – P03: Port 0
 P10 – P13: Port 1
 P20 – P23: Port 2
 P30 – P33: Port 3
 P40 – P43: Port 4
 P50 – P53: Port 5
 P60 – P63: Port 6
 PH0 – PH3: Port H
 T0 – T1: Digit output
 S0 – S11: Segment output
 PP0: Pulse output
 BUZ: Fixed frequency output

$\overline{\text{SCK}}$: Serial clock input/output
 SO: Serial output/serial input/output
 SI: Serial input
 INT0, INT1: External vector interrupt input
 INT2: External test input
 INT4: External vector interrupt input
 T10: Timer input
 X1, X2: Main system clock oscillation pin
 XT1, XT2: Subsystem clock oscillation pin
 RESET: Reset input
 VLOAD, VPRE: FIP driver power pin

● Function of Digital Input/Output Port Pins

Pin	Input/Output	Pin with which used	Function	Type of Input/Output Circuit	
P00	Input	INT4	4-bit input port (Port 0)	B	
P01	Input/Output	\overline{SCK}		F	
P02	Input/Output	S0		G	
P03	Input	SI		B	
P10	Input	INT0	4-bit input port (Port 1)	B	
P11		INT1			w/ noise reduction function
P12		INT2			w/ noise reduction function
P13		T10			
P20	Input/Output	—	4-bit input/output port (Port 2)	E	
P21		—			
P22		—			
P23		BUZ			
P30 – P33	Input/Output	—	Programmable 4-bit input/output port (Port 3) Input/output settable in bit units.	E	
P40 – P43	Input/Output	—	4-bit input/output port (Port 4) Direct drive of LED possible.	E	
P50 – P53	Input/Output	—	4-bit input/output port (Port 5) Direct drive of LED possible.	E	
P60 – P63	Input/Output	—	Programmable 4-bit input/output port (Port 6) Input/output settable in bit units. Built-in pull-down resistor (mask option). Optimum for key input.	V	
PH0	Output	T13	4-bit P-ch open. drain high voltage resistant high current output port (Port H). Direct drive of LED possible. Built-in pull-down resistor (mask option).	I	
PH1		T12			
PH2		T11			
PH3		T10			

● Function of Other Pins

Pin	Input/Output	Pin with which used	Function	Type of Input/Output Circuit	
T0 – T9	Output	–	FIP controller/ driver output pins. Bit units built-in pull-down resistor (mask option)	I	
T10 – T13		PH3 – PH0			High voltage resistant high current output pin for digit output. Leftover pins can be used for Port H.
T14 / S11 T15 / S10		–			High voltage resistant high current output pin for digit/segment output. Static output possible.
S9		–			High voltage resistant output pin for segment output. Static output possible.
S0 – S8		–			High voltage resistant output pin for segment output.
PP0	Output	–	Time/pulse generator pulse output pin.	D	
T10	Input	P13	External event pulse input to timer/event counter.	B	
\overline{SCK}	Input/Output	P01	Serial clock input/output pin.	F	
SO	Input/Output	P02	Serial data output pin or serial data input pin.	G	
SI	Input	P03	Serial data input pin, or normal input pin.	B	
INT4	Input	P00	Edge detection vector interrupt input pin. (detection of either leading or trailing edge)	B	
INT0	Input	P00	Edge detection vector interrupt input pin w/ noise reduction. (detected edge settable)	B	
INT1		P11			
INT2	Input	P12	Edge detection testable input pin. (detection of leading edge)	B	
BUZ	Input/Output	P23	Fixed frequency output pin. (for buzzer or system clock trimming)	E	
X1, X2		–	Crystal/ceramic connection pin for main system clock generation. For external clock, input to X1, X2 open.		
XT1, XT2		–	Crystal connection pin for subsystem clock generation. For external clock, input to XT1, XT2 open.		
\overline{RESET}	Input	–	System reset input pin. (low level active)	B	
V _{PRE}		–	FIP controller/driver output buffer power supply pin.	I	
V _{LOAD}		–	FIP controller/driver pull-down resistor connection pin.	I	
V _{DD}		–	Regular power source pin.		
V _{SS}		–	GND potential pin.		

● Pin Input/Output Circuits

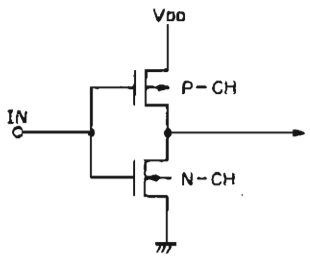
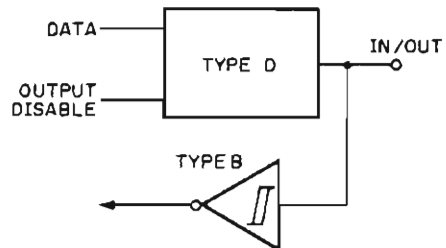
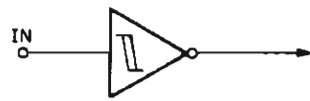
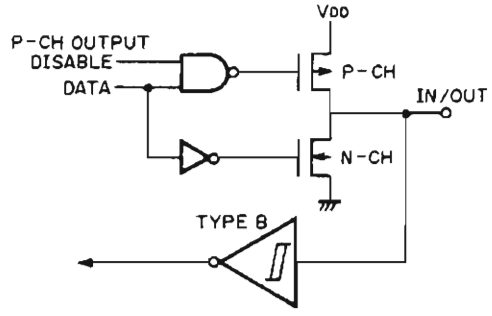
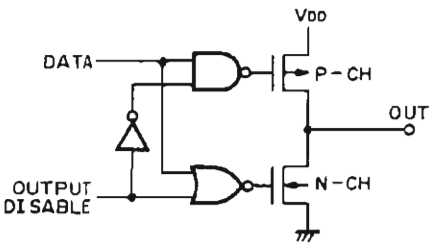
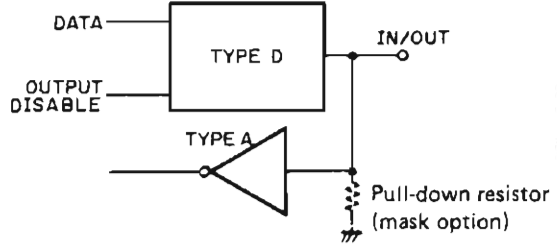
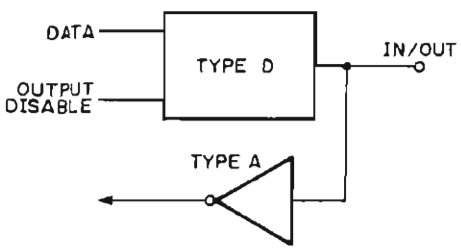
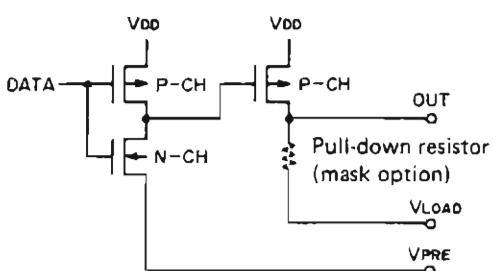
<p>TYPE A</p>  <p>Input buffer conforming to CMOS standards.</p>	<p>TYPE F</p>  <p>Input/output circuit consisting of Type D pushable output and Type B Schmitt trigger input.</p>
<p>TYPE B</p>  <p>Schmitt trigger input with hysteresis.</p>	<p>TYPE G</p>  <p>Input/output circuit which can be switched between pushable output and N-ch open drain output (P-ch off).</p>
<p>TYPE D</p>  <p>Pushable output in which output can be given high impedance (both P-ch and N-ch off).</p>	<p>TYPE V</p>  <p>Pull-down resistor (mask option)</p>
<p>TYPE E</p>  <p>Input/output circuit consisting of Type D pushable output and Type A input buffer.</p>	<p>TYPE I</p>  <p>Pull-down resistor (mask option)</p> <p>VLOAD</p> <p>VPRE</p>

2. Distribution of Voltage for Circuit Diagrams

Excluding the main amplifier, the voltages of the ICs and transistors for the various circuits differ totally depending on the function, mode and what has been selected by the microprocessor. The following shows the voltages of the various parts on matrices or diagrams.

The following matrix shows the base voltage for main amplifier muting circuit transistors QN51 – QN54, QN56, and QN58.

Operation	QN51 QN52 QN58	QN53 QN54	QN56
Normal operation	-36.5V	-2.2V	-2.2V
When function/mode switched (100 ms pulse)	-36.5V	0.6V	0.6V
When power turned off (until power relay turns off)	-36.5V	0.6V	0.6V
When Dolby calibration switch on	-36.5V	0.6V	-2.2V
When mute switch on	0.6V	-2.2V	-2.2V
After monitor operation	-36.5V	-2.2V	0.6V

NOTE: When the voltage is 0.6 V, the transistor is on. If the mute switch is on during the after monitor operation, the base of QN51, QN52, and QN58 is of course 0.6 V.

Voltage of Selector Board (PS04) Parts

• QS01

The voltage of pins 10 – 15, 17, 20, and differs according to the position of the DIRECT REC selector on the direct front pocket. The positions of the switch and the IC pin voltage is shown on the following matrix. For pins 20 and 21, the operation is shown on the diagram following. The normal voltage is 0 V.

Selector Position	QS01 Pin No.					
	11	12	13	14	15	10/17
SOURCE	H	H	H	H	H	L
PHONO	L	H	H	H	H	H
TUNER	H	L	H	H	H	H
CD	H	H	L	H	H	H
LV	H	H	H	L	H	H
VCR-1	H	H	H	H	L	H

For H, the voltage should be in the range 16 – 15 volts, 0 to +1.0 V. If no sound is produced from the source when pins 10 and 17 are low, set the capacity of CS41 on the PS84 board to 47 μ F.

Pins 20 and 21 operate as shown below. When any of pins 11 – 15 or 17 is switched to low:

Pin 20—22 waves generated, then stops.

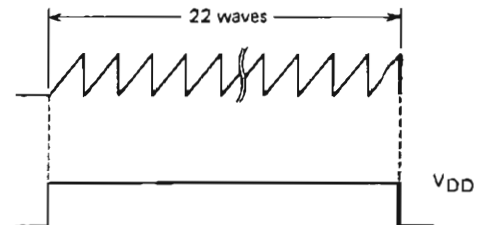

Pin 21 becomes high (same as power source voltage) only while the above 22 waves are being generated.

• QS02

The voltage of pins 11 – 15 differs according to the function selected. Pins 20 and 21 operate in the same way as for QS01.

Selected Function	QS02 Pin No.				
	11	12	13	14	15
TUNER (F specifications only)	L	H	H	H	H
AM/FM (A, E, N, T, W specifications)	L	H	H	H	H
CD	H	H	L	H	H
PHONO	H	L	H	H	H
LV	H	H	H	L	H
TV (F specifications only)	L	H	H	H	H
TV (A, E, N, T, W specifications)	H	H	H	H	L
Others (TAPE, VCR-1, VCR-2)	*	*	*	*	*

* indicates that the voltage directly before the function in selected is held. Thus, if VCR-1 is selected after CD, pin 13 is low, the others are high.

● QS03, QS04, and QS05

The voltage of the QS03 – QS05 control pins (5, 6, 12, and 13) differ according to the selected function, as follows:

Selected Function	QS03		QS04				QS05	
	5, 6	12, 13	5	6	12	13	5, 6	12, 13
TAPE	L	L	L	H	H	L	H	H
VCR-1	H	L	H	L	L	H	L	H
VCR-2	L	H	H	L	L	H	H	L
After Monitor TAPE	L	L	H	H	H	H	H	H
After Monitor VCR-1	H	L	H	L	L	H	*	H
After Monitor VCR-2	L	H	H	L	L	H	H	H
Others	L	L	H	L	L	H	H	H

*: Low when the DIRECT REC SELECTOR is at the VCR-1 position, otherwise high.

H = +13 – 16 V, L = –16 – –13 V.

● QS06, QS11, QS13 and QS12, QS14

This is a 5-element transistor array, consisting of an NPN (QS06, QS11, and QS13) and PNP (QS12 and QS14) transistors. The circuit is shown below. Pins 1 and 7 are common pins (emitter) and are connected internally.

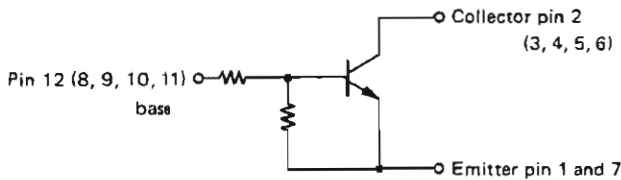

The output is low 0 V (QS06) – 16 V (QS12, QS14) depending on the QS07 signal.

Elements A and B in the QS08 constitute a set-reset flip-flop. A \square signal enters B pins 1 and 2 from the microprocessor board (PU04) only during after-monitoring, pin 9 becomes low (0 V), pin 6 becomes high (5 V), voltage shift (+16 V) is performed between QS11 pins 11 – 2 and QS12 pins 11 – 2, and QG07 pins 5 and 6 become high (16 V).

Element C operates in the same way when the TAPE, VCR-1, or VCR-2 function is selected (including after monitoring), making QG06 pins 5 and 6 low (–16 V) and switching the monitor section and source section on the input side.

QS15 – QS18, QS24, and QG08 generate the inverted signals of the various signals.

● QS07

QS07 is an IC for expanding the microprocessor ports. One of pins 5 – 9 and one of pins 10, 12 – 20 emit a high signal depending on the command from the microprocessor. The relationship between the selected modes or functions and the voltage of the pins is shown below.

Selected Mode	QS07 Pin No.				
	5	6	7	8	9
Dolby	L	L	L	L	H
Matrix	L	L	L	H	L
Spacial	L	L	H	L	L
Stereo	L	H	L	L	L
Mono	H	L	L	L	L

Selected Function	QS07 Pin No.							
	10	13	14	15	17	18	19	20
TUNER (AM/FM)	L	L	L	L	L	L	L	H
PHONO	L	L	L	L	L	L	H	L
CD	L	L	L	L	L	H	L	L
TAPE	L	L	L	L	H	L	L	L
LV	L	L	L	H	L	L	L	L
TV	L	L	H	L	L	L	L	L
VCR-1	L	H	L	L	L	L	L	L
VCR-2	H	L	L	L	L	L	L	L

Initially Dolby and TUNER (or FM) are selected, so pins 5 and 20 are high.

● PL04 (VIDEO AMP)

Status	QL06 base	QL05 collector and QL04 Pin 12	QL05 base	QL06 collector and QL14 Pin 13	QL07 base	QL07 collector and QL14 Pin 14	QL08 base	QL08 collector and QL14 Pin 15	QL14 Pin 5	QL09 base	QL09 collector and QL01 Pin 6	QL14 Pin 4	QL10 base	QL10 collector and QL01 Pin 5	QL14 Pin 3	QL11 base	QL11 collector and QL01 Pin 12	QL14 Pin 2	QL12 base	QL12 collector and QL01 Pin 13
Function - TV	0	6.8	0.6	0	0	6.8	0	6.8	6.8	6.8	-6.8	0	6.2	6.8	6.8	6.8	-6.8	6.8	6.8	-6.8
Function - LV	0	6.8	0	6.8	0	6.8	0.6	0	6.8	6.8	-6.8	6.8	6.8	-6.8	6.8	6.8	-6.8	0	6.2	6.8
Function - VCR-1	0.6	0	0	6.8	0	6.8	0	6.8	0	6.2	6.8	6.8	6.8	-6.8	6.8	6.8	-6.8	6.8	6.8	-6.8
Function - VCR-2	0	6.8	0	6.8	0.6	0	0	6.8	6.8	6.8	-6.8	6.8	6.8	-6.8	0	6.2	6.8	6.8	6.8	-6.8
Function - other audio	0	6.8	0	6.8	0	6.8	0	6.8	6.8	6.8	-6.8	6.8	6.8	-6.8	6.8	6.8	-6.8	6.8	6.8	-6.8
Function - after monitor VCR-1	0.6	0	0	6.8	0	6.8	0	6.8	0	6.2	6.8	6.8	6.8	-6.8	6.8	6.8	-6.8	6.8	6.8	-6.8
Function - after monitor VCR-2	0	6.8	0	6.8	0.6	0	0	6.8	6.8	6.8	-6.8	6.8	6.8	-6.8	0	6.2	6.8	6.8	6.8	-6.8
Function - after monitor TAPE	0	6.8	0	6.8	0	6.8	0	6.8	6.8	6.8	-6.8	6.8	6.8	-6.8	6.8	6.8	-6.8	6.8	6.8	-6.8

NOTES 1) 0 refers to a voltage of 0 V - 0.3 V, 6.8 V is the power source voltage.

2) -6.8 is the negative power source voltage. For both ±6.8, a discrepancy of 0.3 V can be tolerated.

3) QL14 has a latch function, so if an audio function is selected after a video function (TV, LV, VCR-1, or VCR-2), the circuits have stored the status for the previous selection. When checking video functions (including after monitor), always change only between video functions to avoid errors.

4) QL01 is an analog switch which switches the monitor output.

5) QL04 pin 9 only has a voltage of 6.8 V when one of QL14 pins 12 - 15 is 0. If there is no input, the voltage is 0.

Status	QL22 base	QL22 collector	QL23 base	QL23 collector and QL03 Pin 26	QL24 base	QL24 collector and QL02 Pin 6	QL25 base	QL25 collector	QL03 Pin 4	QL03 Pins 8 and 12	QL03 Pins 1, 10 and 13	QL03 Pins 6, 9, and 11	QL09 Pin 3 and QL02 Pin 12	QL02 Pin 6	QL02 Pin 13
DIRECT REC SELECTOR - LV	0.8	0	6.2	6.8	9.3	-6.8	6.2	6.8	-6.8	*	*	*	-6.8	6.8	6.8
DIRECT REC SELECTOR - VCR-1	0.6	0	6.2	6.8	6.2	6.8	6.2	-6.8	-6.8	*	*	*	-6.8	-6.8	-6.8
DIRECT REC SELECTOR - other than LV, VCR-1, and SOURCE	0.6	0	6.2	6.8	9.3	-6.8	9.3	-6.8	-6.8	*	*	*	-6.8	-6.8	-6.8
DIRECT REC SELECTOR - SOURCE, Function - video (TV or LV)	0	6.8	6.8	-6.8	9.3	-6.8	9.3	-6.8	**	**	**	**	**	6.8	**
DIRECT REC SELECTOR - SOURCE, Function - VCR-1, VCR-2, and audio	0	6.8	6.8	-6.8	9.3	-6.8	9.3	-6.8	***	***	***	***	***	6.8	***

NOTES * If the TV function is selected, QL03 pins 8, 9, 9, and 11 have a voltage of 6.8 V, and pins 1, 10, and 13 have a voltage of -6.8 V. If LV is selected, this is reversed, and there is no output, so ignore.

** When TV is selected, QL03 pins 8, 9, 9, and 11 have a voltage of 6.8 V, pins 1, 4, 10, 12, and 13 a voltage of -6.8 V. For LV, this is reversed.

*** Voltages are that of the previously selected function (either TV or LV). For the voltage distribution, refer to note ** above.

3. PL14 P.W. Board

	QL26 Base	QL26 Collector	QL27 Base	QL27 Collector
(1) When function LV, VCR-1, or VCR-2 is selected:	0.8	0	14.4	15
(2) When other functions are selected:	0	15	15	0

Normal pulse only when remote control signal is input.



The voltage of the collector depends on the connected euro-connector (21-pin).

Open (0 V) when no euro-connector is connected.

4. P604 P.W. Board

● Dolby (P604) Board Semi-conductor Voltage Matrix

Selected Mode	Q561				Q562			Q563		Q564			
	5	6	12	13	5	6, 12	13	Base	Coil	Base	Coil		
Dolby	L	L	H	L	L	L	H	H	-0.6V	H	L	+0.6V	L
Matrix	L	H	L	H	L	L	H	H	-0.6V	H	L	-0.6V	L
Spatial	H	H	L	L	L	L	L	H	L	L	L	+0.6V	L
Stereo	L	L	L	L	L	L	H	H	-0.6V	H	L	H	H
Mono	H	L	L	L	H	H	H	H	-0.6V	H	L	H	H

NOTE: H refers to a + power source voltage within the range of 16 V to 13 V.

L refers to a - power source voltage within the range of -16 V to -13 V.

Discrepancies in the voltage are due to voltage drop in the diodes and transistor in the circuit.

Discrepancies of the power source voltage x 0.7 can be tolerated for the above Q561 and Q562 pins, for both high and low.

The input/output voltage of operational amplifier NTM4558 is shown as 0 V. However, there are variations as potential for voltages of 0 V to ±100 mV due to input drift of the various OP amps, but this can be ignored.

5. BLOCK DIAGRAM

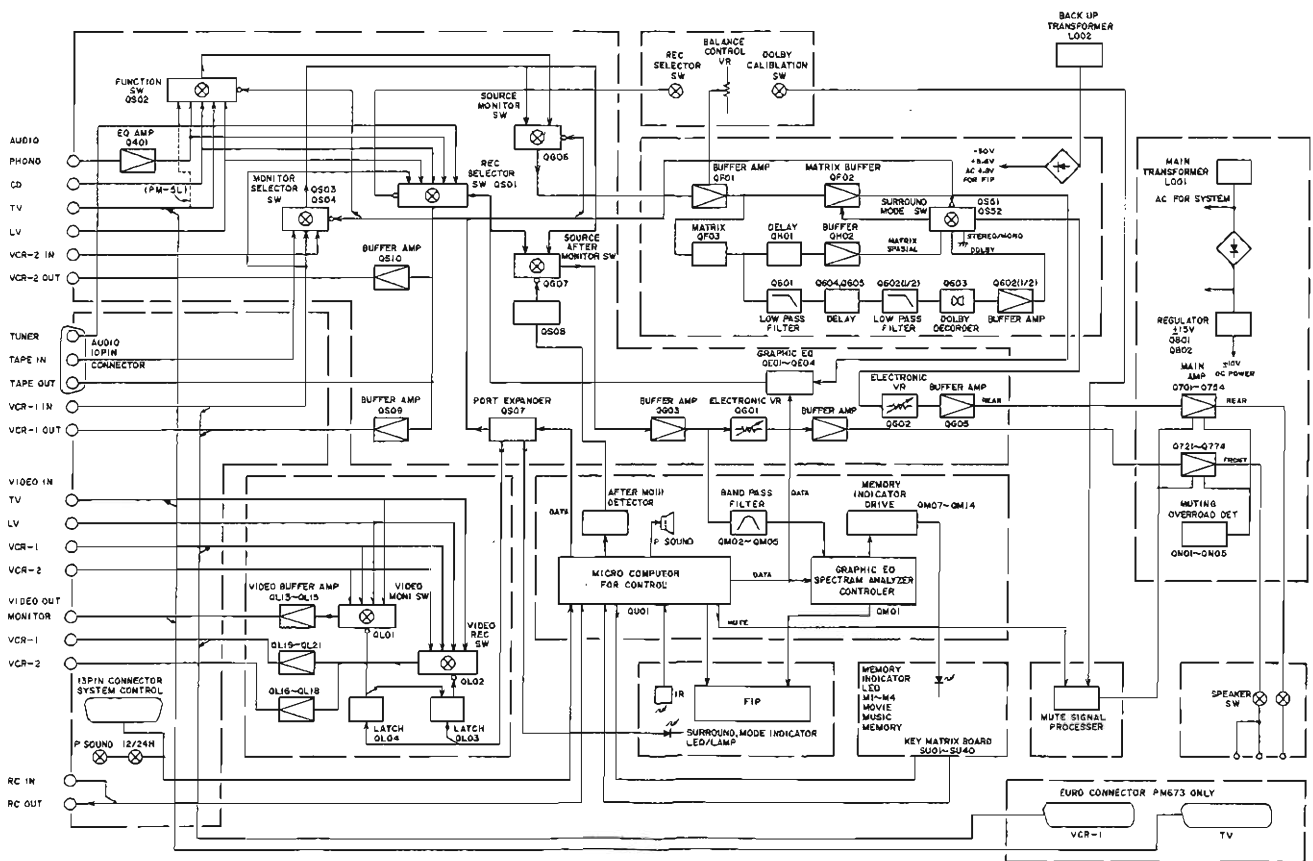

6. SCHEMATIC DIAGRAM

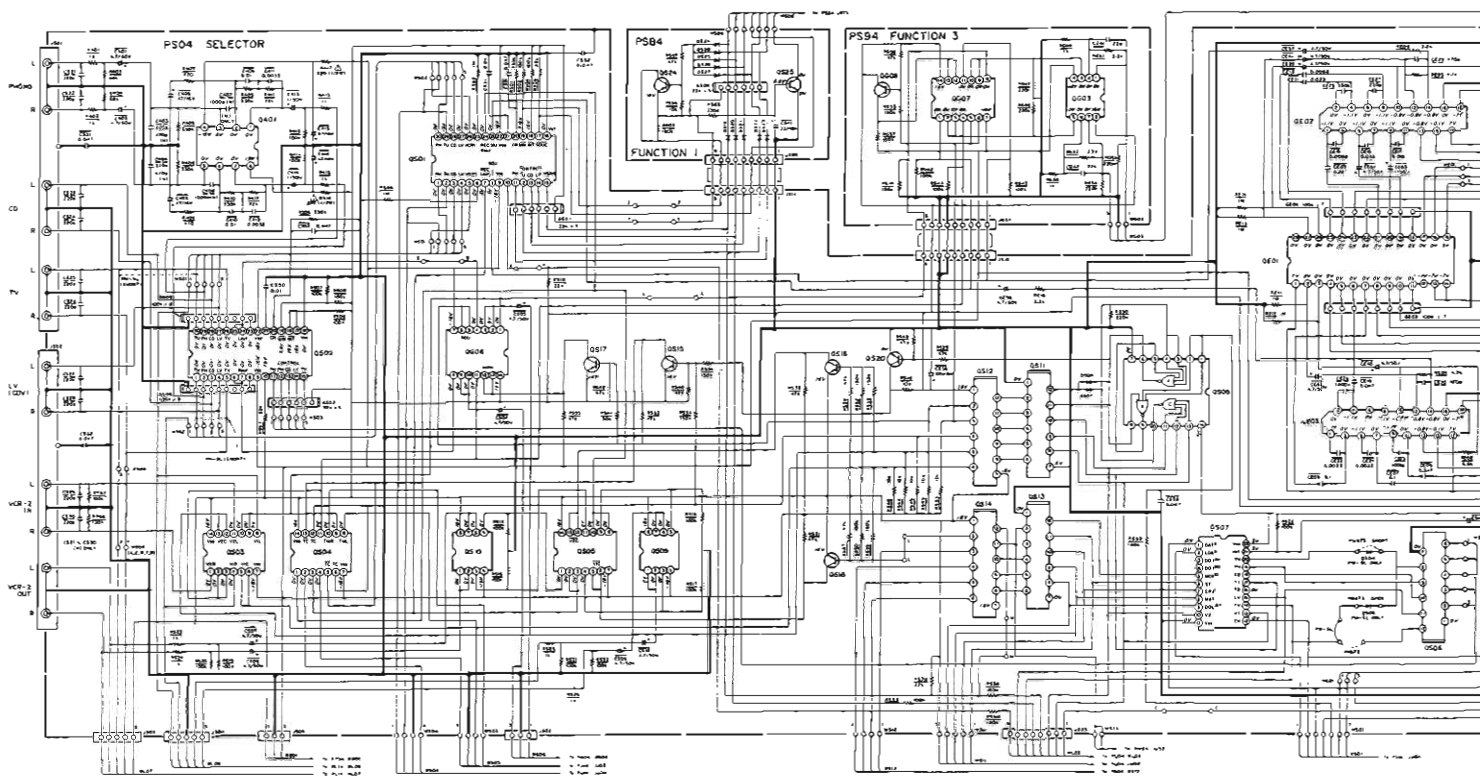

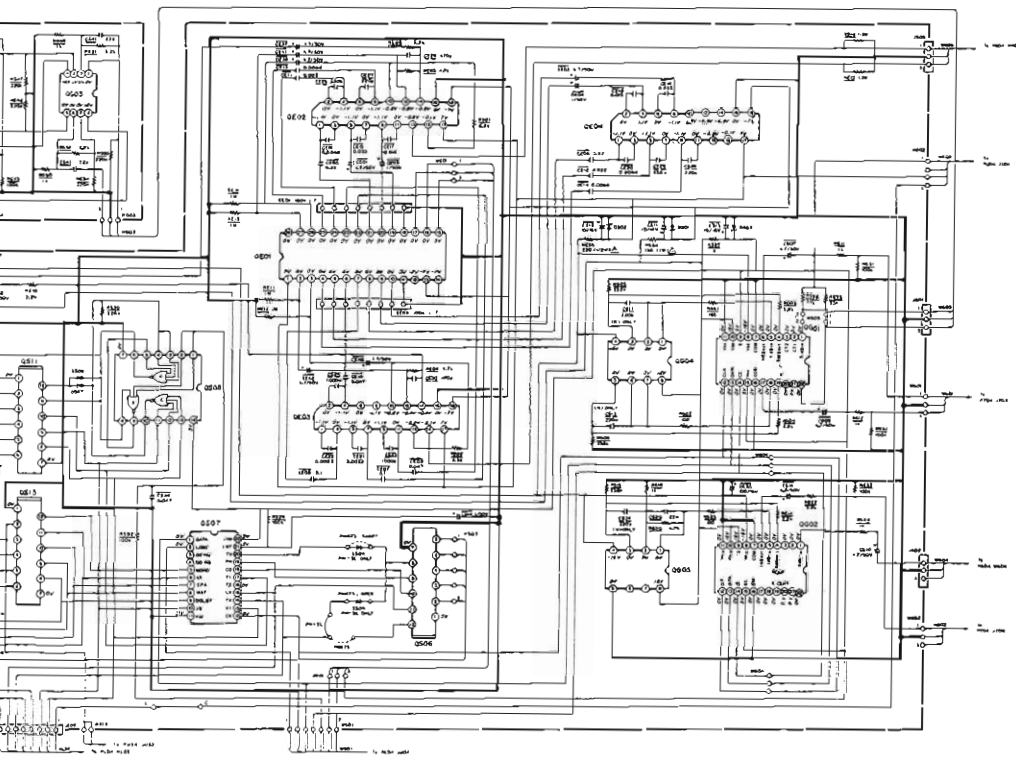

- Q601
- LC7325
- Q602-Q604
- BA5912L
- Q601, Q602
- LC7935
- Q603-Q605, Q609
- Q610, Q601
- NJM4558D-Q
- Q606, Q607
- Q608-Q608
- LC4966
- Q601, Q602
- LC7818
- Q606, Q611, Q613
- DT5C144E
- Q607
- M3M59371NE
- Q608
- P040258C
- Q618, Q614
- DT5A144E
- Q609, Q613-Q614
- Q609
- 25A4008PFP, (J)
- Q620, Q625
- 25C3368PFP, (J)
- TOP VIEW
- LC7818
- TOP VIEW
- LC7822
- TOP VIEW
- M3M59371NS
- DT5C144E
- DT5A144E
- 25C3368PFP, (J)
- 25A4008PFP, (J)
- M3M12L

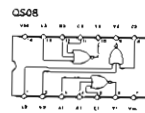
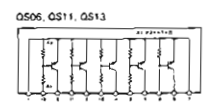
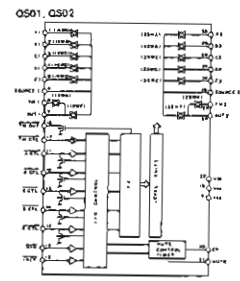
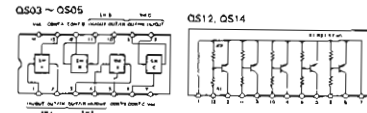
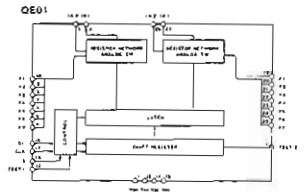

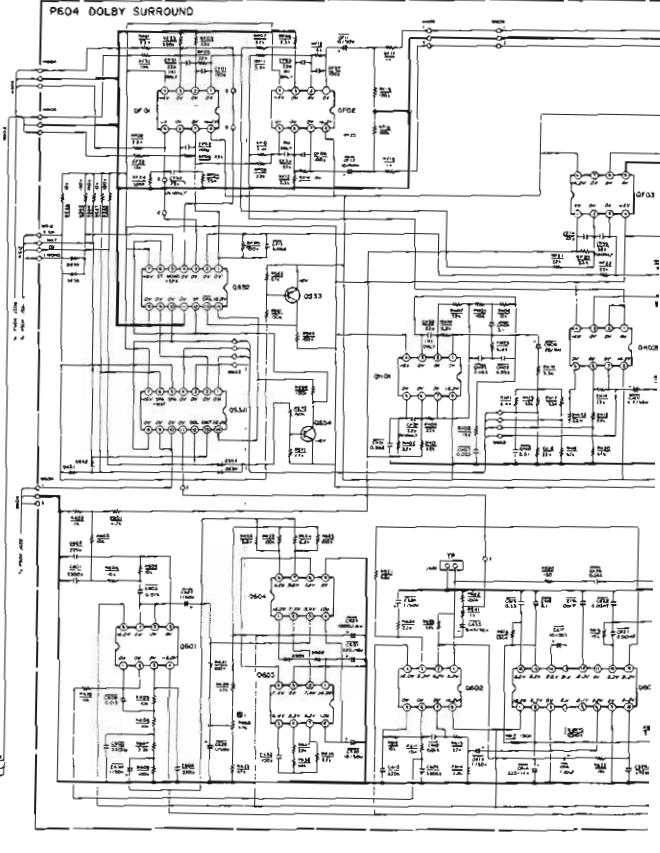
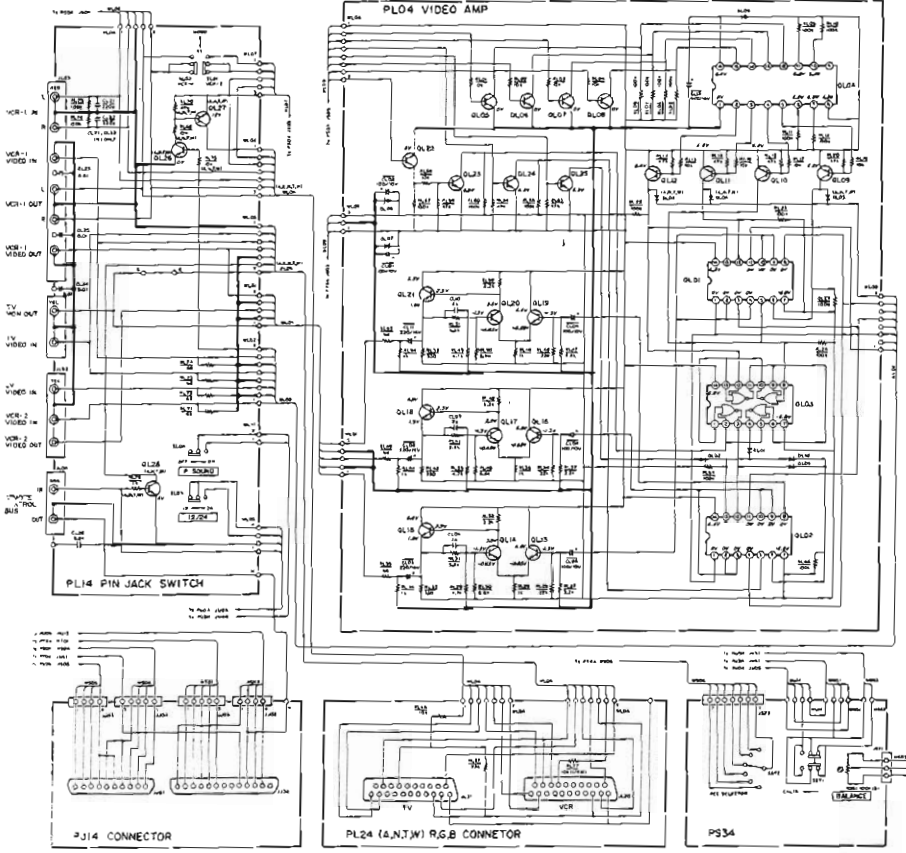

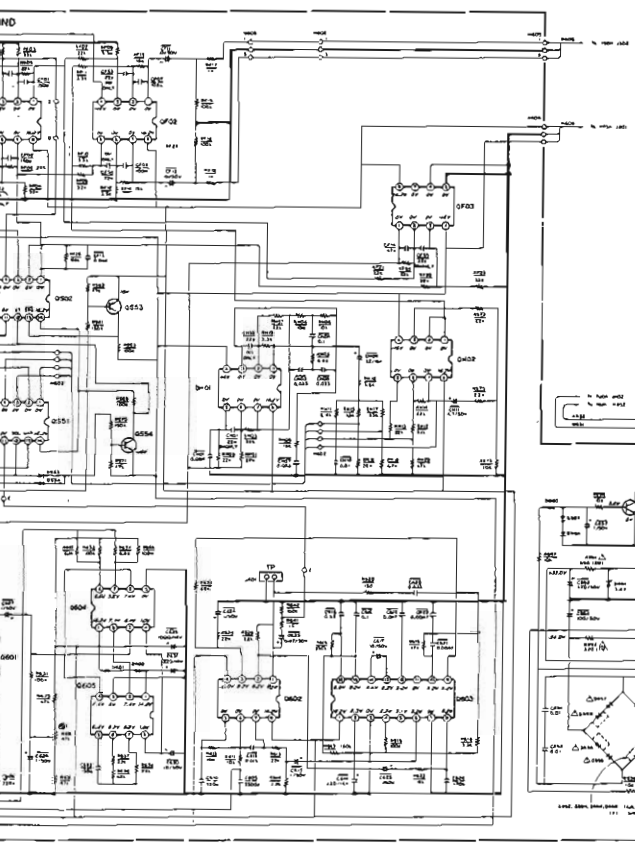

- Q601, Q602, Q603, Q604, Q605, Q606, Q607, Q608, Q609, Q610, Q611, Q612, Q613, Q614, Q615, Q616, Q617, Q618, Q619, Q620, Q621, Q622, Q623, Q624, Q625, Q626, Q627, Q628, Q629, Q630, Q631, Q632, Q633, Q634, Q635, Q636, Q637, Q638, Q639, Q640, Q641, Q642, Q643, Q644, Q645, Q646, Q647, Q648, Q649, Q650, Q651, Q652, Q653, Q654, Q655, Q656, Q657, Q658, Q659, Q660, Q661, Q662, Q663, Q664, Q665, Q666, Q667, Q668, Q669, Q670, Q671, Q672, Q673, Q674, Q675, Q676, Q677, Q678, Q679, Q680, Q681, Q682, Q683, Q684, Q685, Q686, Q687, Q688, Q689, Q690, Q691, Q692, Q693, Q694, Q695, Q696, Q697, Q698, Q699, Q700, Q701, Q702, Q703, Q704, Q705, Q706, Q707, Q708, Q709, Q710, Q711, Q712, Q713, Q714, Q715, Q716, Q717, Q718, Q719, Q720, Q721, Q722, Q723, Q724, Q725, Q726, Q727, Q728, Q729, Q730, Q731, Q732, Q733, Q734, Q735, Q736, Q737, Q738, Q739, Q740, Q741, Q742, Q743, Q744, Q745, Q746, Q747, Q748, Q749, Q750, Q751, Q752, Q753, Q754, Q755, Q756, Q757, Q758, Q759, Q760, Q761, Q762, Q763, Q764, Q765, Q766, Q767, Q768, Q769, Q770, Q771, Q772, Q773, Q774, Q775, Q776, Q777, Q778, Q779, Q780, Q781, Q782, Q783, Q784, Q785, Q786, Q787, Q788, Q789, Q790, Q791, Q792, Q793, Q794, Q795, Q796, Q797, Q798, Q799, Q800, Q801, Q802, Q803, Q804, Q805, Q806, Q807, Q808, Q809, Q810, Q811, Q812, Q813, Q814, Q815, Q816, Q817, Q818, Q819, Q820, Q821, Q822, Q823, Q824, Q825, Q826, Q827, Q828, Q829, Q830, Q831, Q832, Q833, Q834, Q835, Q836, Q837, Q838, Q839, Q840, Q841, Q842, Q843, Q844, Q845, Q846, Q847, Q848, Q849, Q850, Q851, Q852, Q853, Q854, Q855, Q856, Q857, Q858, Q859, Q860, Q861, Q862, Q863, Q864, Q865, Q866, Q867, Q868, Q869, Q870, Q871, Q872, Q873, Q874, Q875, Q876, Q877, Q878, Q879, Q880, Q881, Q882, Q883, Q884, Q885, Q886, Q887, Q888, Q889, Q890, Q891, Q892, Q893, Q894, Q895, Q896, Q897, Q898, Q899, Q900, Q901, Q902, Q903, Q904, Q905, Q906, Q907, Q908, Q909, Q910, Q911, Q912, Q913, Q914, Q915, Q916, Q917, Q918, Q919, Q920, Q921, Q922, Q923, Q924, Q925, Q926, Q927, Q928, Q929, Q930, Q931, Q932, Q933, Q934, Q935, Q936, Q937, Q938, Q939, Q940, Q941, Q942, Q943, Q944, Q945, Q946, Q947, Q948, Q949, Q950, Q951, Q952, Q953, Q954, Q955, Q956, Q957, Q958, Q959, Q960, Q961, Q962, Q963, Q964, Q965, Q966, Q967, Q968, Q969, Q970, Q971, Q972, Q973, Q974, Q975, Q976, Q977, Q978, Q979, Q980, Q981, Q982, Q983, Q984, Q985, Q986, Q987, Q988, Q989, Q990, Q991, Q992, Q993, Q994, Q995, Q996, Q997, Q998, Q999, Q1000.

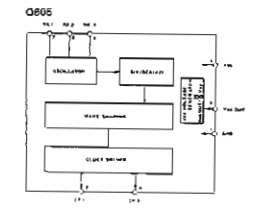
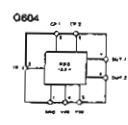
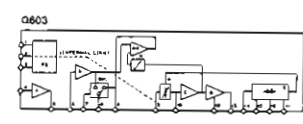
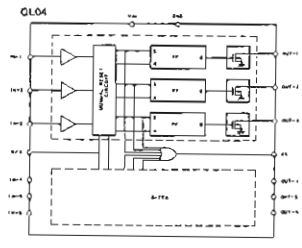
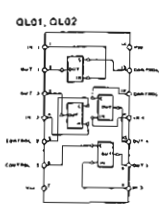

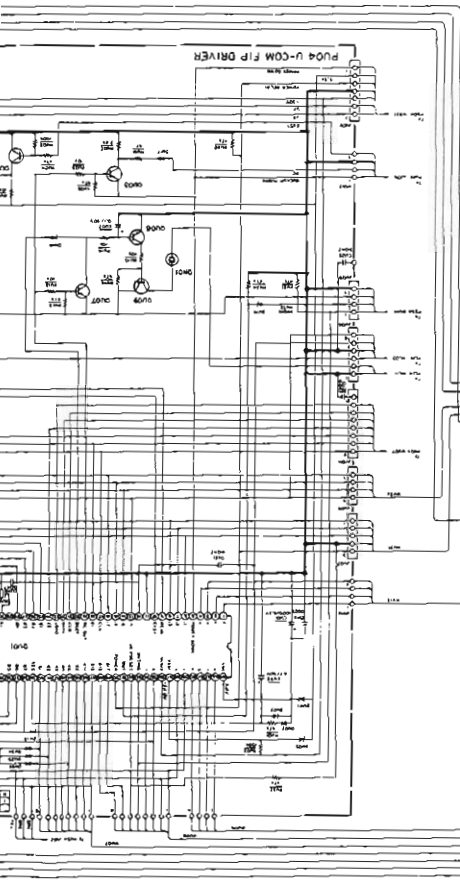
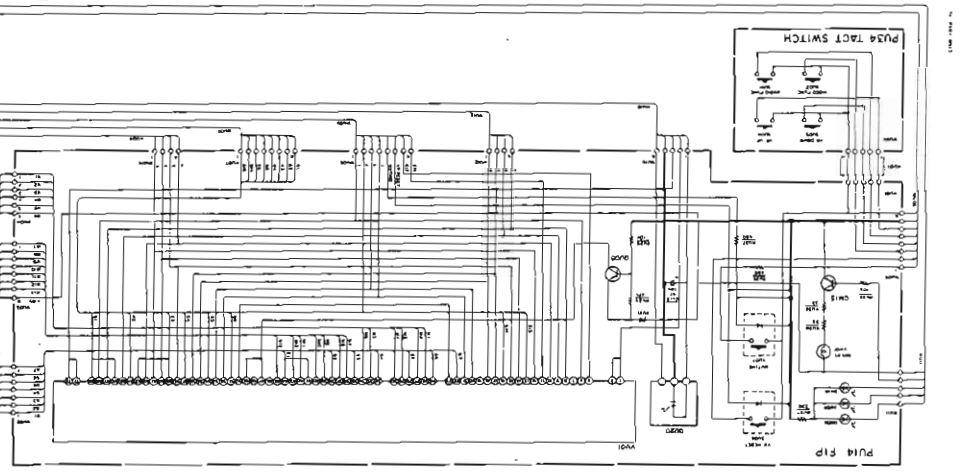
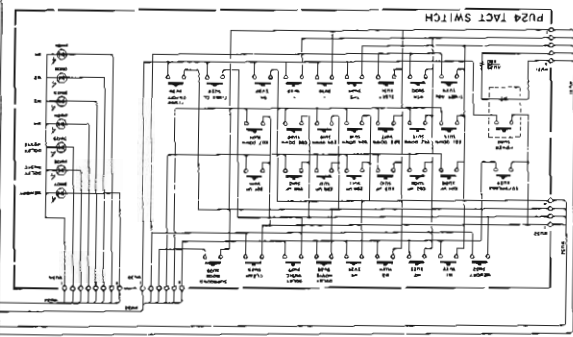
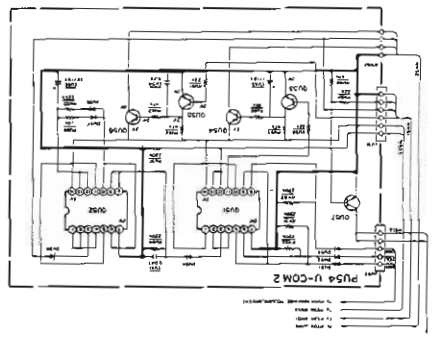
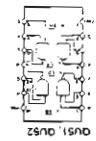

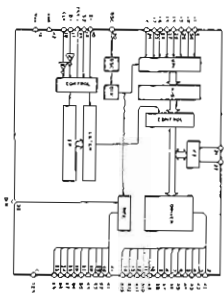
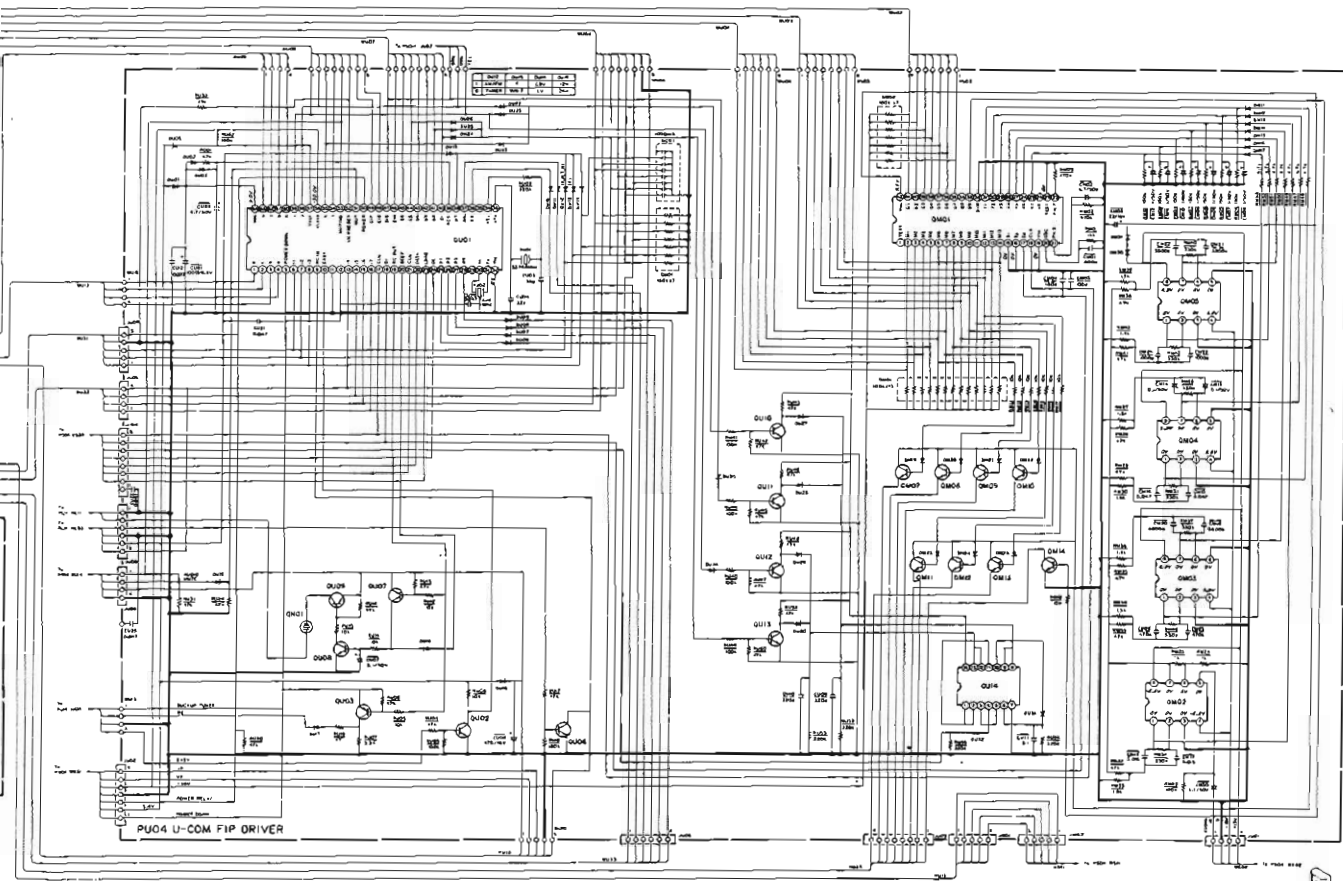

- QW01 QM01~QM10
- LC7545 L7300B
- QM02~QM05 QM11~QM19 QM20
- QM21~QM23 QM24~QM25
- QM26~QM27 QM28~QM29 QM30
- QM31~QM32 QM33~QM34 QM35
- QM36~QM37 QM38~QM39 QM40
- QM41~QM42 QM43~QM44 QM45
- QM46~QM47 QM48~QM49 QM50
- QM51~QM52 QM53~QM54 QM55
- QM56~QM57 QM58~QM59 QM60
- QM61~QM62 QM63~QM64 QM65
- QM66~QM67 QM68~QM69 QM70
- QM71~QM72 QM73~QM74 QM75
- QM76~QM77 QM78~QM79 QM80
- QM81~QM82 QM83~QM84 QM85
- QM86~QM87 QM88~QM89 QM90
- QM91~QM92 QM93~QM94 QM95
- QM96~QM97 QM98~QM99 QM100
- QM101~QM102 QM103~QM104 QM105
- QM106~QM107 QM108~QM109 QM110
- QM111~QM112 QM113~QM114 QM115
- QM116~QM117 QM118~QM119 QM120
- QM121~QM122 QM123~QM124 QM125
- QM126~QM127 QM128~QM129 QM130
- QM131~QM132 QM133~QM134 QM135
- QM136~QM137 QM138~QM139 QM140
- QM141~QM142 QM143~QM144 QM145
- QM146~QM147 QM148~QM149 QM150
- QM151~QM152 QM153~QM154 QM155
- QM156~QM157 QM158~QM159 QM160
- QM161~QM162 QM163~QM164 QM165
- QM166~QM167 QM168~QM169 QM170
- QM171~QM172 QM173~QM174 QM175
- QM176~QM177 QM178~QM179 QM180
- QM181~QM182 QM183~QM184 QM185
- QM186~QM187 QM188~QM189 QM190
- QM191~QM192 QM193~QM194 QM195
- QM196~QM197 QM198~QM199 QM200

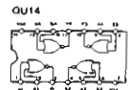
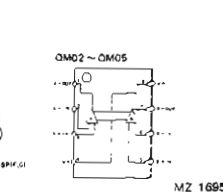

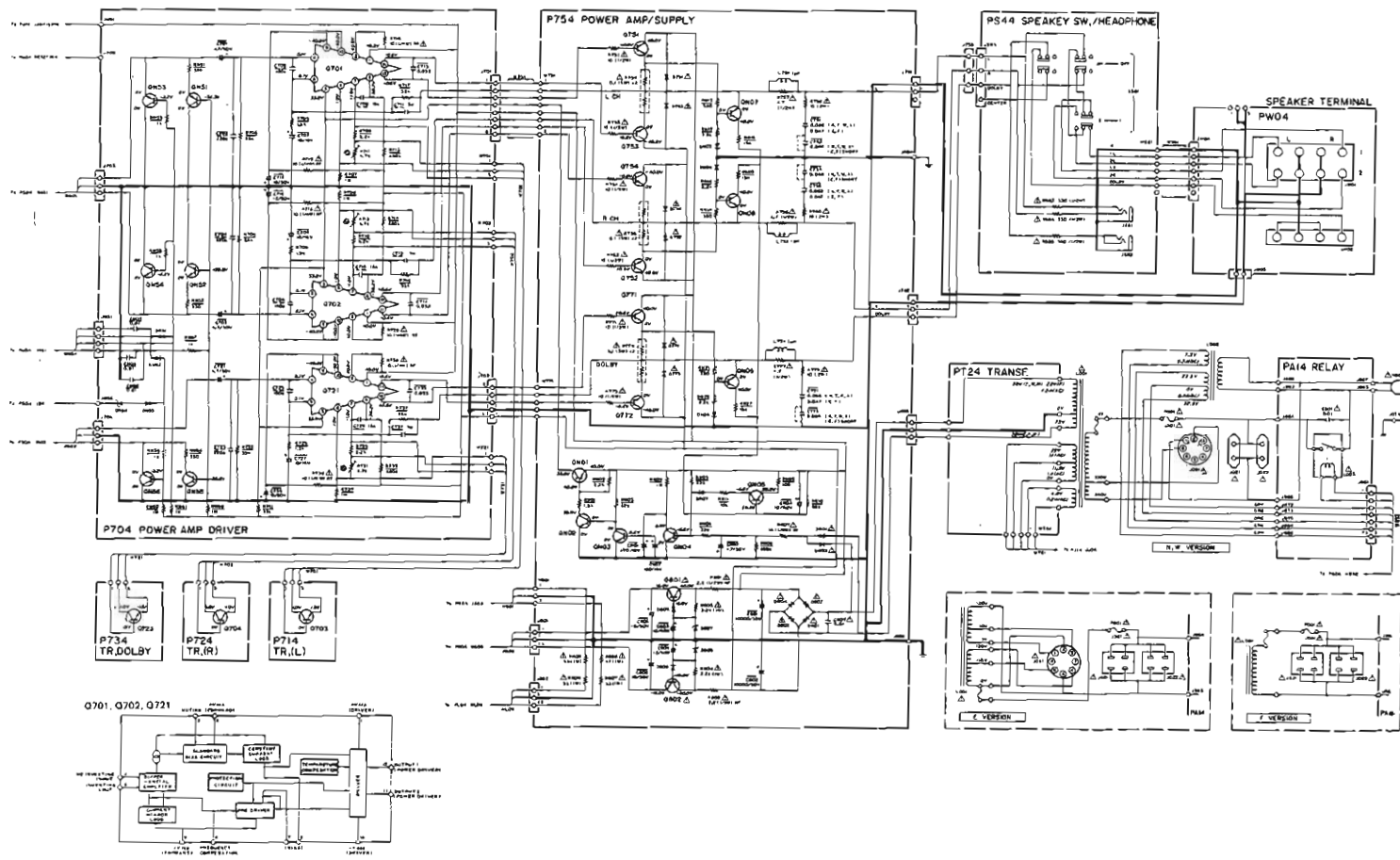

- Q701, Q702
- Q703, Q704
- Q705, Q706
- Q707, Q708
- Q709, Q710
- Q711, Q712
- Q713, Q714
- Q715, Q716
- Q717, Q718
- Q719, Q720
- Q721, Q722
- Q723, Q724
- Q725, Q726
- Q727, Q728
- Q729, Q730
- Q731, Q732
- Q733, Q734
- Q735, Q736
- Q737, Q738
- Q739, Q740
- Q741, Q742
- Q743, Q744
- Q745, Q746
- Q747, Q748
- Q749, Q750
- Q751, Q752
- Q753, Q754
- Q755, Q756
- Q757, Q758
- Q759, Q760
- Q761, Q762
- Q763, Q764
- Q765, Q766
- Q767, Q768
- Q769, Q770
- Q771, Q772
- Q773, Q774
- Q775, Q776
- Q777, Q778
- Q779, Q780
- Q781, Q782
- Q783, Q784
- Q785, Q786
- Q787, Q788
- Q789, Q790
- Q791, Q792
- Q793, Q794
- Q795, Q796
- Q797, Q798
- Q799, Q800

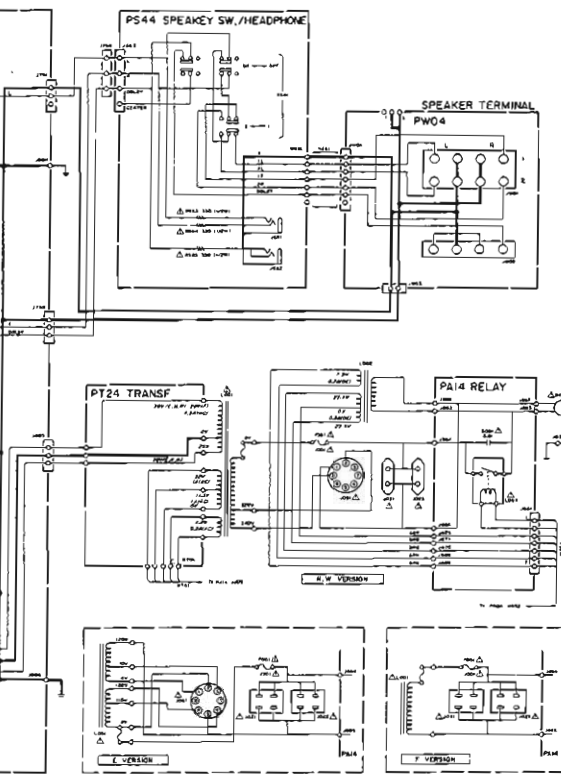

- 0701,0702,0721
- 0703,0704,0723
- 25C24181Y1
- 0761,732,0771
- 25D171412,P1
- 0753,0754,0772
- 15B115113,P1
- 0801
- 25D12650,P1
- 0802
- 15A130610,Y1
- 0751-0754,0771
- 0773,0802,0807
- 0601-0604
- 53V20
- 0802,0806
- 0803-0805,0807
- 0808-0853
- 155133, etc.
- 0807,0808
- 16V
- 0854
- 12V

- 0N01
- 25A6069P1,01
- 0N02,0N03-0N08
- 25C2781FF,01
- 0N03,0N04
- 25C5188P1F,01
- 0N05
- 25A11701FF,01
- 0N06,0N07,0N08
- 0N09
- 25C28781A1

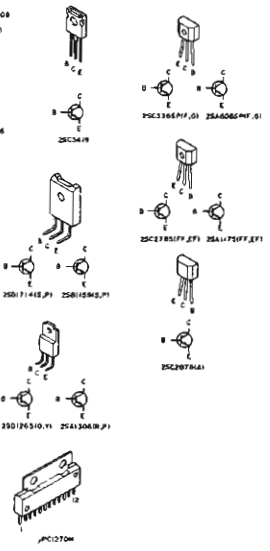

7. WIRING DIAGRAM

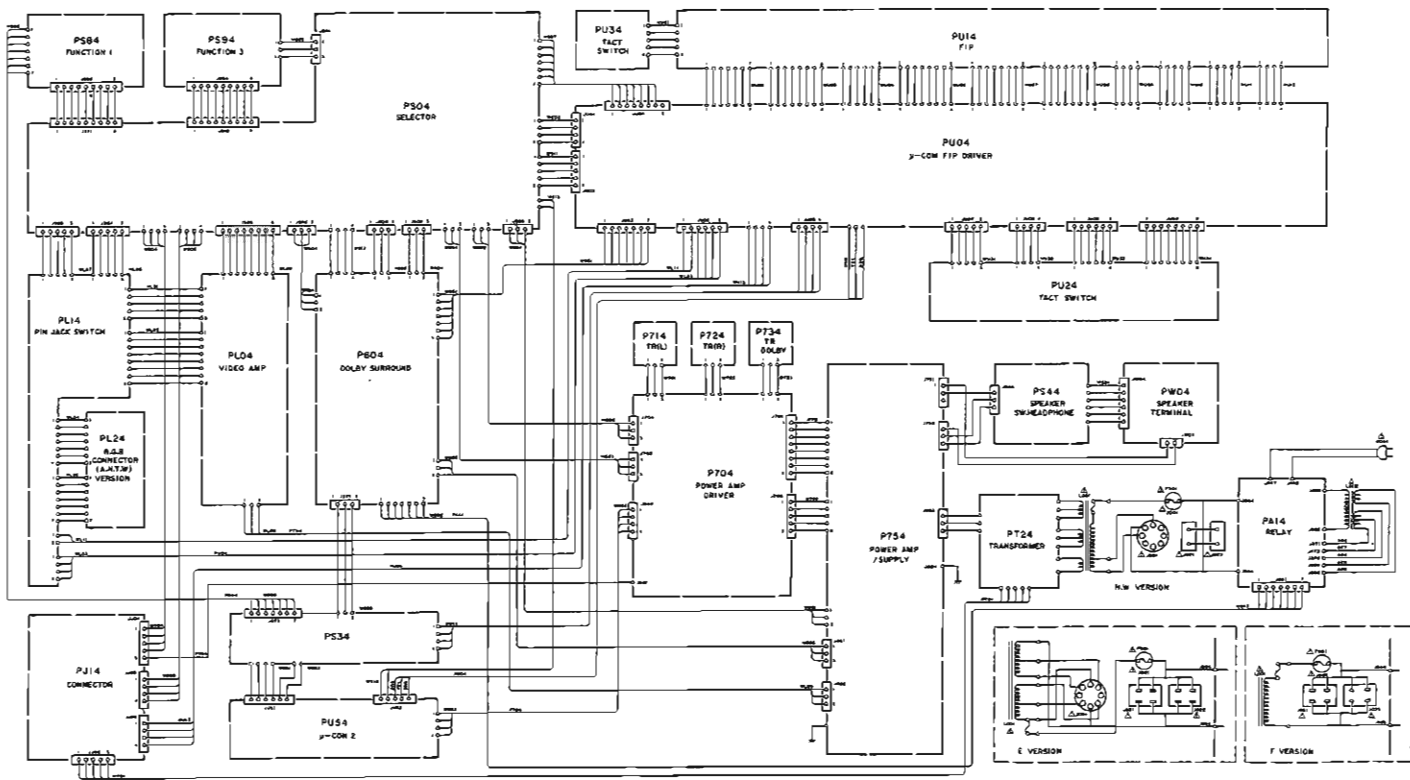

8. COMPONENT LOCATIONS

Video Amp. (PL04)

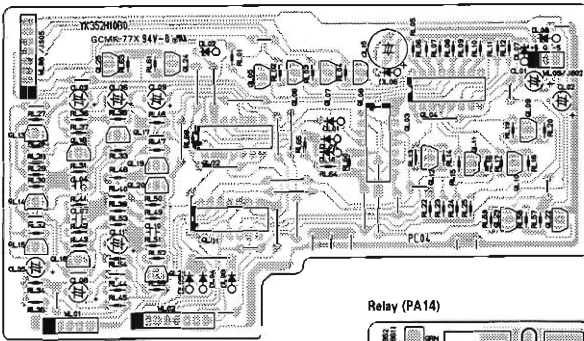

Relay (PA14)

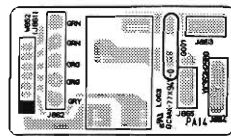

Pin Jack Switch (PL14)

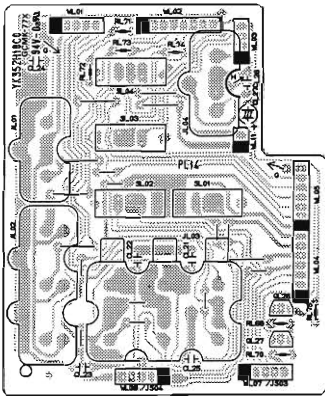

Connector (PJ14)

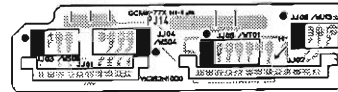

R. G. B. Connector (PL24)

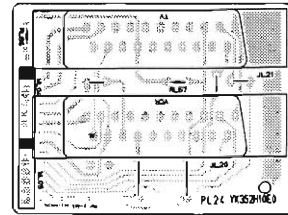

U-COM 2 (PU54)

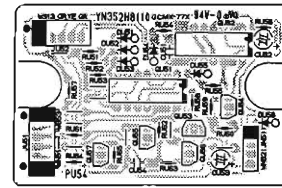

Transf. Wire (PT24)

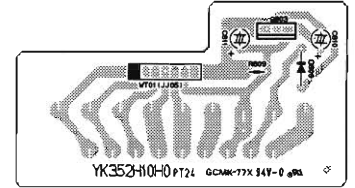

Speaker Terminal (PW04)

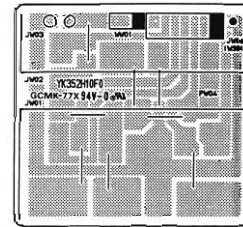

Tact (PU24)

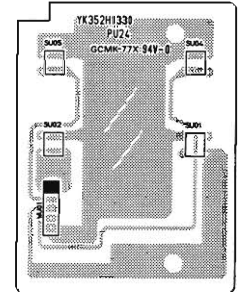

Power Amp. Driver (P704)

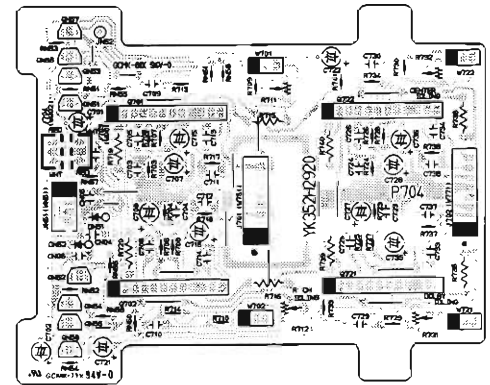

Selector (PS04)

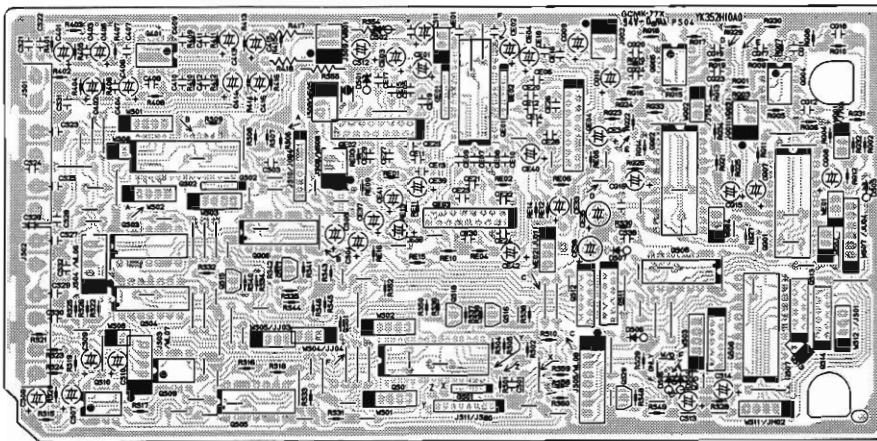

Rec Selector (PS34)

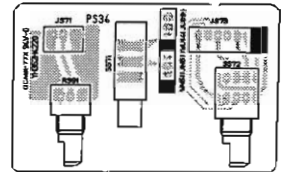

Speaker Switch (PS44)

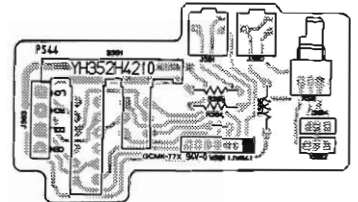

U-COM FL Driver (PU04)

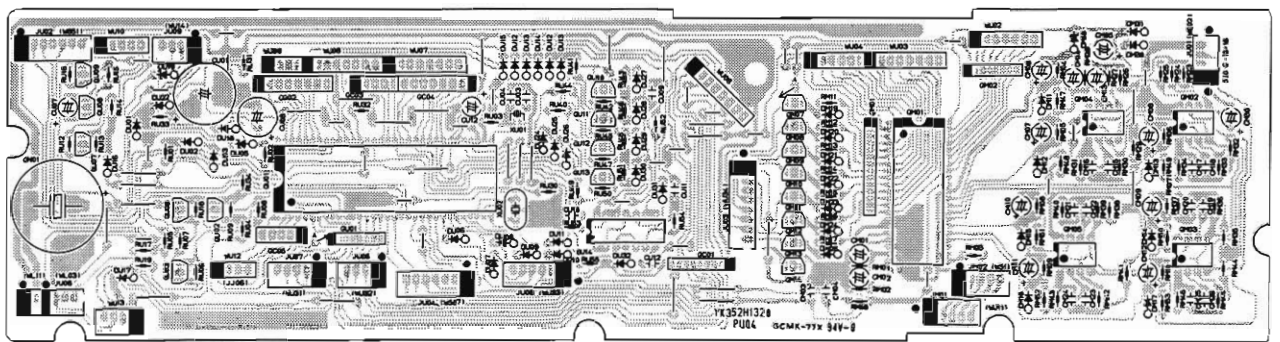

9. EXPLODED VIEW AND PARTS LIST

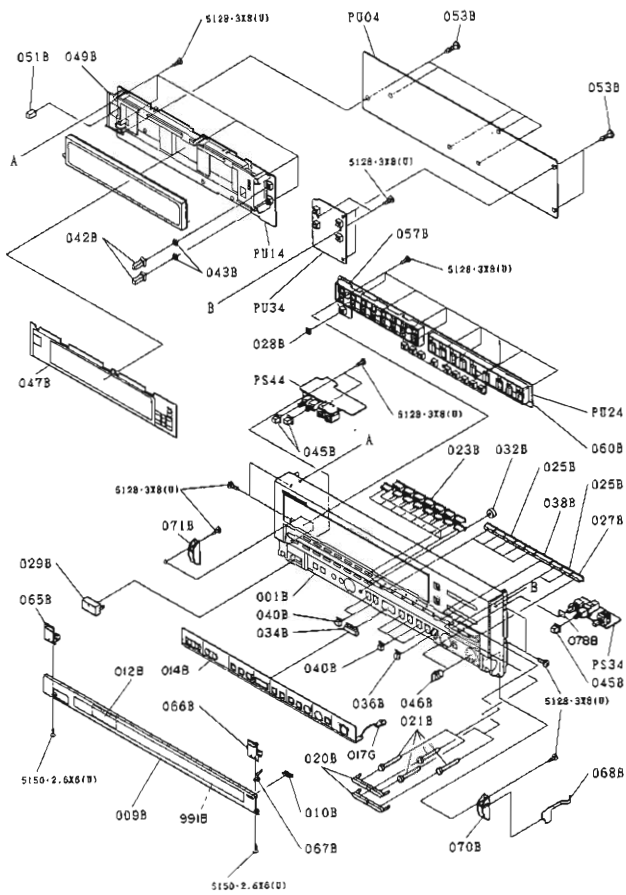

REF. DESIG.	PART NO.	DESCRIPTION
001B	4822 426 51191	Front Panel Assembly
009B	4822 454 11967	Escutcheon, Hinge
010B	4822 412 20098	Knob, Hinge
014B	4822 454 30391	Indicator Assembly
020B	4822 410 25819	Button, Volume
021B	4822 535 71094	Pin, Volume
022B	4822 410 25821	Button, EQ
025B	4822 410 25822	Button, Surround
027B	4822 410 25823	Button, Mode
028B	4822 532 51719	Bushing, Power Switch
029B	4822 410 25829	Button, K, Power Switch
032B	4822 410 25825	Button, Timer
034B	4822 410 25826	Button, Timer Mode
036B	4822 410 25827	Button, Clear
038B	4822 410 25828	Button, EQ Flat
040B	4822 410 25782	Button, Tact
042B	4822 381 10696	Lens, Muting
043B	4822 532 51718	Bushing, Muting
045B	4822 410 25753	Button, Pan
046B	4822 412 20897	Knob, Volume
065B	4822 417 10985	Hinge, Left
066B	4822 417 10986	Hinge, Right
067B	4822 278 80277	Contact
068B	4822 278 80281	Contact
070B	4822 526 50097	Click, Right
071B	4822 526 50098	Click, Left

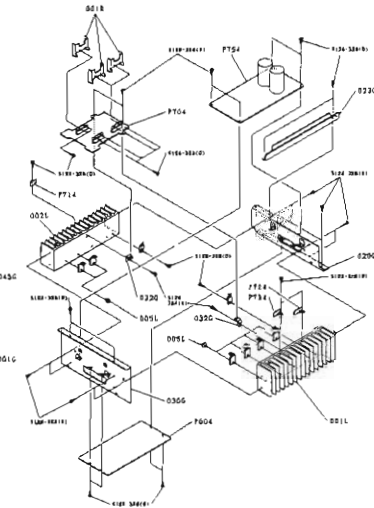
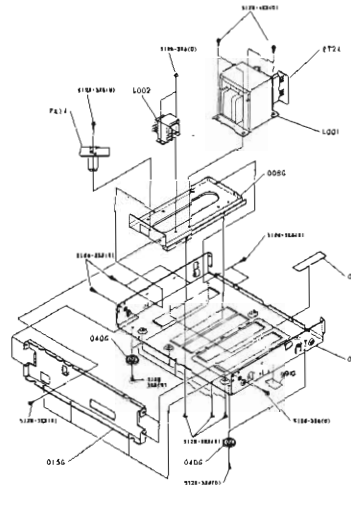
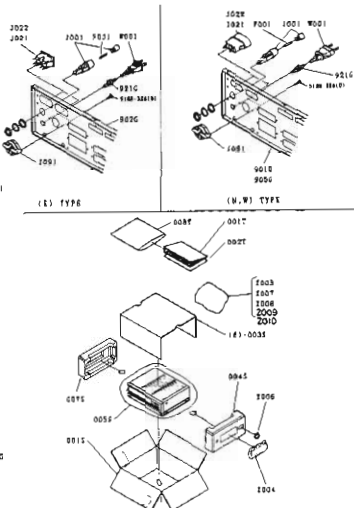
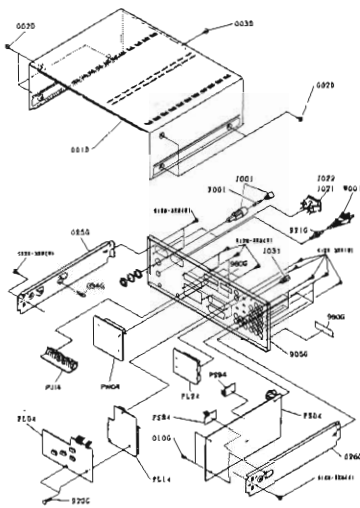

REF. DESIG.	PART NO.	DESCRIPTION
001D	4822 426 51233	Lid, Top Cover
002D	4822 502 12385	B.T. Screw 83 x 8
003D	4822 502 12355	B.T. Screw 93 x 8
010G	4822 530 80277	Clamper
034G	4822 530 80277	Clamper
901G	4822 426 20118	Rear Panel [N]
902G	4822 426 20137	Rear Panel [E]
905G	4822 426 20138	Rear Panel [W]
920G	4822 535 11081	Spacer, Video P.W. Board
921G	4822 532 51314	Bushing, AC Power Cord
Δ F001	4822 253 30024	Fuse 1.6A 250V
Δ J001	4822 265 30233	Jack, Fuse Holder
Δ J021	4822 267 30587	Jack, AC Outlet [N, W]
	4822 265 10051	Jack, AC Outlet [E]
Δ J022	4822 265 10587	Jack, AC Outlet [N, W]
	4822 265 10091	Jack, AC Outlet [E]
Δ J031	4822 290 40297	Terminal, GND
Δ J091	4822 272 10236	Voltage Selector [N, W]
	4822 272 10235	Voltage Selector [E]
Δ W001	4822 321 10428	A.C. Power Cord [N, W]
	4822 321 10429	A.C. Power Cord [E]

REF. DESIG.	PART NO.	DESCRIPTION
		PACKING
001S	4822 600 70472	Packing Case [N, W]
004S	4822 600 70473	Cushion, Right
005S	4822 600 70347	Polyethylene Sheet
001T	4822 736 13576	User Manual
008T	4822 600 70363	Polyethylene Bag
2003	4822 321 21443	Connective Cord
2004	4822 218 10203	Remoon Unit (RMC-73)
2006	4822 138 10156	Battery, SUM-3
2007	4822 321 22384	Connective Cord, 10P
2008	4822 321 22388	Connective Cord, 13P
2009	4822 253 30148	Fuse [E]
2010	4822 265 10092	Jack, AC Adaptor [E]

REF. DESIG.	PART NO.	DESCRIPTION
001G	4822 464 50894	Chassis K, Main
040G	4822 462 41186	Leg
991G	4822 600 70229	Label, Caution

REF. DESIG.	PART NO.	DESCRIPTION
001R	4822 265 40581	Heatsink, Sub
Δ L001	4822 148 60173	Power Transformer, Main [N, W]
	4822 148 60175	Power Transformer, Main [E]
L002	4822 148 60166	Power Transformer, Sub [N, W]
	4822 148 60174	Power Transformer, Sub [E]

ASSIGNMENT OF COMMON PARTS CODES.

RESISTOR

- R***: (1) GD05 --- 140, Carbon film fixed resistor, $\pm 5\%$, 1/4W
 R***: (2) GD05 --- 180, Carbon film fixed resistor, $\pm 5\%$, 1/6W

① — Resistance value

Examples

① Resistance value

0.1 Ω ...001	10 Ω ...100	1k Ω ...102	100k Ω ...104
0.5 Ω ...005	18 Ω ...180	2.7k Ω ...272	680k Ω ...684
1 Ω ...010	100 Ω ...101	10k Ω ...103	1Mk Ω ...105
6.8 Ω ...068	390 Ω ...391	22k Ω ...223	4.7Mk Ω ...475

(Note) Please distinguish 1/4W from 1/6W by the shape of parts used actually.

C***: CERAMIC CAP.

- (1) DD1 --- 370, Ceramic condenser
 Disc type
 Temp. coeff. P350 ~ N1000, 50V
- ① ②
- Capacity value
 Tolerance

Examples

- ① Tolerance (Capacity deviation)
- | |
|--------------------------|
| $\pm 0.25\text{pF}$...0 |
| $\pm 0.5\text{pF}$...1 |
| $\pm 5\%$...5 |

* Tolerance of COMMON PARTS handled here are as follows:

- | |
|------------------------------------|
| 0.5pF ~ 5pF... $\pm 0.25\text{pF}$ |
| 6pF ~ 10pF... $\pm 0.5\text{pF}$ |
| 12pF ~ 560pF... $\pm 5\%$ |
- ② Capacity value
- | | | |
|-------------|------------|-------------|
| 0.5pF...005 | 3pF...030 | 100pF...101 |
| 1pF...010 | 10pF...100 | 220pF...221 |
| 1.5pF...015 | 47pF...470 | 560pF...561 |

C***: CERAMIC CAP.

- (1) DK16 --- 300, High dielectric constant ceramic condenser
 Disc type
 Temp. chara. 2B4, 50V
- ①
- Capacity value

Example

- ② Capacity value
- | | | |
|-------------|--------------|---------------|
| 100pF...101 | 1000pF...102 | 10000pF...103 |
| 470pF...471 | 2200pF...222 | |

C***: ELECTROLY CAP. ($\frac{\mu}{\text{F}}$), FILM CAP. ($\frac{\mu}{\text{F}}$)

- (1) EA --- 10, Electrolytic condenser
 One-way lead type, Tolerance $\pm 20\%$
- ① ②
- Dielectric strength
 Capacity value

Examples

- ① Capacity value
- | | | |
|---------------------------|--------------------------|---------------------------|
| 0.1 μF ...104 | 4.7 μF ...475 | 100 μF ...107 |
| 0.33 μF ...334 | 10 μF ...106 | 330 μF ...337 |
| 1 μF ...105 | 22 μF ...226 | 1100 μF ...108 |
| | | 2200 μF ...228 |

- ② Working voltage
- | | |
|------------|-----------|
| 6.3V...006 | 25V...025 |
| 10V...010 | 35V...035 |
| 16V...016 | 50V...050 |

- (2) DF15 --- 350, Plastic film condenser
 One-way type, Mylar $\pm 5\%$ 50V
- ①
- Capacity value

Examples

- ① Capacity value
- | | |
|------------------------------------|---------------------------|
| 0.001 μF (1000pF)...102 | 0.1 μF ...104 |
| 0.0018 μF ...182 | 0.56 μF ...564 |
| 0.01 μF ...103 | 1 μF ...105 |
| 0.015 μF ...153 | |

10. ELECTRICAL PARTS LIST

REF. DESIG.	PART NO.	DESCRIPTION
Δ G001	4822 122 40305	PA14-RELAY CIRCUIT BOARD Ceramic Cap. 0.01 μF 400V
J861	4822 265 10064	Jack, 7P
Δ L003	4822 280 70219 4822 280 70331	Relay (N, W) Relay (E)
JJ01	4822 266 30305	PJ14-CONNECTOR CIRCUIT BOARD Terminal, 10P
JJ02	4822 266 30306	Terminal, 13P
JJ03	4822 265 10105	Jack, 4P
JJ04	4822 265 10061	Jack, 5P
JJ05	4822 265 10064	Jack, 7P
JJ06	4822 265 10105	Jack, 4P
		PL04-VIDEO AMP CIRCUIT BOARD
		PL04-CAPACITORS
CL04	4822 122 40297	Ceramic 2pF $\pm 0.25\text{pF}$
CL07	4822 122 40297	Ceramic 2pF $\pm 0.25\text{pF}$
CL10	4822 122 40297	Ceramic 2pF $\pm 0.25\text{pF}$
		PL04-SEMICONDUCTORS
DL01	4822 130 33305	Diode 1SS133, etc.
DL02	4822 130 33305	Diode 1SS133, etc.
DL03	4822 130 33305	Diode 1SS133, etc. (N, W)
DL04	4822 130 33305	Diode 1SS133, etc. (N, W)
DL05	4822 130 33305	Diode 1SS133, etc. (N, W)
DL06	4822 130 33305	Diode 1SS133, etc.
DL07	4822 130 80318	Zener RD6.8J
DL08	4822 130 80318	Zener RD6.8J
DL09	4822 130 33305	Diode 1SS133, etc.
DL10	4822 130 33305	Diode 1SS133, etc.
QL01	4822 209 83067	IC LC4066B
QL02	4822 209 83067	IC LC4066B
QL03	4822 209 83832	IC LC4001B
QL04	4822 209 71781	IC TC9135P
QL05		
}	4822 130 42483	Transistor 2SC536SP (F, G)
QL08		
QL09		
}	4822 130 42715	Transistor 2SA608SP (F, G)
QL12		
QL13		
}	4822 130 42483	Transistor 2SC536SP (F, G)
QL22		
QL23	4822 130 42715	Transistor 2SA608SP (F, G)
QL24	4822 130 42715	Transistor 2SA608SP (F, G)
QL25	4822 130 42715	Transistor 2SA608SP (F, G)

REF. DESIG.	PART NO.	DESCRIPTION
WL02	4822 323 10183	PL04-MISCELLANEOUS Jumper Lead, 8P
WL08	4822 323 10119	
WL09	4822 323 10107	
		PL14-PIN JACK/SW. CIRCUIT BOARD
		PL14-CAPACITORS
CL23	4822 122 32486	Ceramic 0.01 μ F +80% -20%
CL24	4822 122 32486	Ceramic 0.01 μ F +80% -20%
CL25	4822 122 32486	Ceramic 0.01 μ F +80% -20%
CL26	4822 122 32486	Ceramic 0.01 μ F +80% -20%
		PL14-SEMICONDUCTORS
QL26	4822 130 42483	Transistor 2SC536SP(F, G) [N, W]
QL27	4822 130 42715	Transistor 2SA608SP(F, G) [N, W]
QL28	4822 130 42483	Transistor 2SC536SP(F, G) [N, W]
		PL14-MISCELLANEOUS
JL01	4822 266 30301	Terminal, 2P; RCA
JL02	4822 266 30302	Terminal, 3P; RCA
JL03	4822 266 30304	Terminal, 6P; RCA
JL04	4822 266 30236	Terminal, 2P; RCA
SL01	4822 277 21146	Slide Switch
SL02	4822 277 21146	Slide Switch
SL03	4822 277 21146	Slide Switch
SL04	4822 277 21146	Slide Switch
WL01	4822 323 10159	Jumper Lead, 5P
WL04	4822 323 10119	Jumper Lead, 7P
WL05	4822 323 10119	Jumper Lead, 7P
WL06	4822 323 10113	Jumper Lead, 5P
WL11	4822 323 10286	Jumper Lead, 2P
		PL24-R.G.B. CONNECTOR CIRCUIT BOARD
JL20	4822 266 30307	Terminal, 21P; RGB
JL21	4822 266 30307	Terminal, 21P; RGB
		PS04-SELECTOR CIRCUIT BOARD
		PS04-CAPACITORS
CS50	4822 122 32486	Ceramic 0.01 μ F +80% -20%
CS51	4822 122 32486	Ceramic 0.01 μ F +80% -20%
CS52	4822 122 40306	Ceramic 0.047 μ F +80% -20%

REF. DESIG.	PART NO.	DESCRIPTION
		PS04-RESISTORS
GE01	4822 111 91398	100K Ω x7 Composite
GE02	4822 111 91398	100K Ω x7 Composite
GS01	4822 111 91401	22K Ω x5 Composite
GS02	4822 111 91401	22K Ω x5 Composite
GS05	4822 111 91513	100K Ω x8 Composite
GS06	4822 111 91513	100K Ω x8 Composite
Δ RS54	4822 116 60513	150 Ω \pm 5% $\frac{1}{2}$ W
Δ RS55	4822 111 90727	220 Ω \pm 5% $\frac{1}{2}$ W
R417	4822 111 90727	220 Ω \pm 5% $\frac{1}{2}$ W
R418	4822 111 90727	220 Ω \pm 5% $\frac{1}{2}$ W
		PS04-SEMICONDUCTORS
DS01	4822 130 80318	Zener RD6.8J
DS02	4822 130 80318	Zener RD6.8J
DS03	4822 130 80317	Zener RD5.1J
DS06	4822 130 33305	Diode 1SS133
DS07	4822 130 33305	Diode 1SS133
QE01	4822 209 71783	IC LC7522
QE02	4822 209 83338	IC BA3812L
QE03	4822 209 83338	IC BA3812L
QE04	4822 209 83338	IC BA3812L
QG01	4822 209 71784	IC LC7535
QG02	4822 209 71784	IC LC7535
QG04	4822 209 83631	IC NJM4558D-D
QG05	4822 209 83631	IC NJM4558D-D
QG06	4822 209 83804	IC LC4966
QS01	4822 209 83315	IC LC7818
QS02	4822 209 83315	IC LC7818
QS03	4822 209 83804	IC LC4966
QS04	4822 209 83804	IC LC4966
QS05	4822 209 83804	IC LC4966
QS06	4822 209 71779	IC DT5C144E
QS07	4822 209 83594	IC MSM59371RS
QS08	4822 209 83836	IC μ PD4025BC
QS09	4822 209 83631	IC NJM4558D-D
QS10	4822 209 83631	IC NJM4558D-D
QS11	4822 209 71779	IC DT5C144E
QS12	4822 209 71778	IC DT5A144E
QS13	4822 209 71779	IC DT5C144E
QS14	4822 209 71778	IC DT5A144E
QS15	4822 130 42715	Transistor 2SA608SP(F, G)
QS16	4822 130 42715	Transistor 2SA608SP(F, G)
QS17	4822 130 42715	Transistor 2SA608SP(F, G)
QS18	4822 130 42715	Transistor 2SA608SP(F, G)
QS20	4822 130 42483	Transistor 2SC536SP(F, G)
Q401	4822 209 83631	IC NJM4558D-D
		PS04-MISCELLANEOUS
JG01	4822 265 10062	Jack, 3P
JG02	4822 265 10062	Jack, 3P
JS01	4822 265 30457	Terminal, 6P; RCA
JS02	4822 265 30457	Terminal, 6P; RCA
JS03	4822 265 10061	Jack, 5P
JS04	4822 265 10061	Jack, 5P
JS05	4822 265 10059	Jack, 8P

REF. DESIG.	PART NO.	DESCRIPTION
JS06	4822 265 10078	Plug, 3P
JS08	4822 265 10062	Jack, 3P
JS09	4822 265 10062	Jack, 3P
JS10	4822 267 50779	Jack, 9P
WE01	4822 323 10107	Jumper Lead, 3P
WE02	4822 323 10143	Jumper Lead, 4P
WG01	4822 321 21744	Connective Cord, 3P
WG02	4822 321 21744	Connective Cord, 3P
WG03	4822 323 10107	Jumper Lead, 3P
WG04	4822 323 10105	Jumper Lead, 3P
WG05	4822 323 10104	Jumper Lead, 2P
WS01	4822 323 10113	Jumper Lead, 5P
WS02	4822 323 10092	Jumper Lead, 5P
WS03	4822 323 10056	Jumper Lead, 5P
WS04	4822 323 10056	Jumper Lead, 5P
WS05	4822 323 10112	Jumper Lead, 4P
WS07	4822 323 10188	Jumper Lead, 7P
WS08	4822 323 10104	Jumper Lead, 2P
WS10	4822 323 10114	Jumper Lead, 5P
WS11	4822 323 10155	Jumper Lead, 5P
WS12	4822 323 10128	Jumper Lead, 4P
		PS34-REC SELECTOR CIRCUIT BOARD
RS91	4822 100 20614	Variable Resistor 100K Ω (B)
SS71	4822 276 20458	Push Switch, Surround
SS72	4822 273 70114	Rotary Switch, Speaker
JS71	4822 265 10062	Jack, 3P
JS73	4822 265 10064	Jack, 7P
WN51	4822 323 10089	Jumper Lead, 4P
		PS44-SPEAKER SW. CIRCUIT BOARD
△ RS83	4822 111 90724	Resistor 330 Ω \pm 5% $\frac{1}{2}$ W
△ RS84	4822 111 90724	Resistor 330 Ω \pm 5% $\frac{1}{2}$ W
△ RS85	4822 111 90724	Resistor 330 Ω \pm 5% $\frac{1}{2}$ W
JS81	4822 267 30834	Jack, Headphone
JS82	4822 267 30834	Jack, Headphone
JS83	4822 265 30544	Plug, 4P
SS81	4822 276 20459	Push Switch, Speaker

REF. DESIG.	PART NO.	DESCRIPTION
GS04	4822 111 91401	PS84-FUNCTION-1 CIRCUIT BOARD Resistor Composite 22K Ω x5
DS19 }	4822 130 33305	Diode 1SS133, etc.
DS28		
QS24	4822 130 42715	Transistor 2SA608SP(F, G)
QS25	4822 130 42483	Transistor 2SC536SP(F, G)
JS80	4822 267 50779	Jack, 9P
WS06	4822 323 10196	Jumper Lead, 7P
		PS94-FUNCTION-3 CIRCUIT BOARD
QG03	4822 209 83631	IC NJM4558D-D
QG07	4822 209 83804	IC LC4966
QG08	4822 130 42715	Transistor 2SA608SP(F, G)
		PT24-TRANSFORMER WIRE CIRCUIT BOARD
WT01	4822 323 10094	Jumper Lead, 5P
		PU04-U-COM FL DRIVER CIRCUIT BOARD
		PU04-CAPACITORS
CU03	4822 122 32917	Ceramic 33pF \pm 5%
CU04	4822 122 32143	Ceramic 22pF \pm 5%
CU12	4822 122 40491	Ceramic 0.022 μ F +80% -20%
CU20	4822 122 40306	Ceramic 0.047 μ F +80% -20%
CU21	4822 122 40306	Ceramic 0.047 μ F +80% -20%
CU22	4822 122 40306	Ceramic 0.047 μ F +80% -20%
CU23	4822 122 40306	Ceramic 0.047 μ F +80% -20%
		PU04-RESISTORS
GC01	4822 111 91393	1000P \times 8 C.R. Composite
GM01	4822 111 91397	100K Ω x13 Composite
GM02	4822 111 91398	100K Ω x7 Composite
GU01	4822 111 91398	100K Ω x7 Composite
		PU04-SEMICONDUCTORS
DM11 }	4822 130 33305	Diode 1SS133, etc.
DM17		
DM19 }	4822 130 33305	Diode 1SS133, etc.
DM25		
DM30	4822 130 33305	Diode 1SS133, etc.
DM31	4822 130 33305	Diode 1SS133, etc.

REF. DESIG.	PART NO.	DESCRIPTION
DU01	4822 130 33305	Diode 1SS133, etc.
DU02	4822 130 33305	Diode 1SS133, etc.
DU03	4822 130 33305	Diode 1SS133, etc.
DU05	4822 130 80319	Zener RD9.1JB2
DU06 }	4822 130 33305	Diode 1SS133, etc.
DU11		
DU12	4822 130 33305	Diode 1SS133, etc.
DU15 }	4822 130 33305	Diode 1SS133, etc.
DU18		
DU19	4822 130 80132	Zener RD3.9J
DU22 }	4822 130 33305	Diode 1SS133, etc.
DU35		
QM01	4822 209 71782	IC LC7565
QM02	4822 209 80401	IC NJM4558D-D
QM03	4822 209 80401	IC NJM4558D-D
QM04	4822 209 80401	IC NJM4558D-D
QM05	4822 209 80401	IC NJM4558D-D
QM07 }	4822 130 42483	Transistor 2SC536SP(F, G)
QM14		
QN01	4822 280 10191	Elect Buzzer
QU01	4822 209 71787	Microprocessor μ PD7520B
QU02	4822 130 42483	Transistor 2SC536SP(F, G)
QU03	4822 130 42715	Transistor 2SA608SP(F, G)
QU06	4822 130 42483	Transistor 2SC536SP(F, G)
QU07	4822 130 42715	Transistor 2SA608SP(F, G)
QU08	4822 130 42483	Transistor 2SC536SP(F, G)
QU09	4822 130 42715	Transistor 2SA608SP(F, G)
QU10	4822 130 42483	Transistor 2SC536SP(F, G)
QU11	4822 130 42483	Transistor 2SC536SP(F, G)
QU12	4822 130 42483	Transistor 2SC536SP(F, G)
QU13	4822 130 42483	Transistor 2SC536SP(F, G)
QU14	4822 209 83832	IC 4001
		PU04-MISCELLANEOUS
JM01	4822 265 10061	Jack, 5P
JM02	4822 265 10061	Jack, 5P
JU01	4822 265 10105	Jack, 4P
JU02	4822 265 10064	Jack, 6P
JU03	4822 265 10059	Jack, 7P
JU04	4822 265 10064	Jack, 6P
JU05	4822 265 10105	Jack, 4P
JU06	4822 265 10063	Jack, 6P
JU07	4822 265 10061	Jack, 5P
JU08	4822 265 10063	Jack, 6P
JU09	4822 265 10105	Jack, 4P
WU03	4822 323 10183	Jumper Lead, 8P
WU06	4822 323 10061	Jumper Lead, 8P
XU01	4822 242 71775	Crystal 32.768KHz
XU02	4822 242 71774	Ceramic Bibrator 4.19MHz

REF. DESIG.	PART NO.	DESCRIPTION
		PU14-F.I.P. CIRCUIT BOARD
		PU14-SEMICONDUCTORS
DM08	4822 130 80326	L.E.D. LT3D88
DM09	4822 130 80326	L.E.D. LT3D88
DM10	4822 130 80326	L.E.D. LT3D88
DU21	4822 130 80316	Zener MTZJ3.6A
QM15	4822 130 42483	Transistor 2SC536SP(F, G)
QU05	4822 130 42715	Transistor 2SA608SP(F, G)
QU20	4822 130 10009	Photo Unit
		PU14-MISCELLANEOUS
SU06	4822 276 11559	Push Switch
SU07	4822 276 11559	Push Switch
VM01	4822 134 40853	Lamp 12V
VU01	4822 130 90435	Display Unit FIP18BMW24
WU01	4822 323 10159	Jumper Lead, 5P
WU02	4822 323 10117	Jumper Lead, 7P
WU04	4822 323 10169	Jumper Lead, 6P
WU07	4822 323 10183	Jumper Lead, 8P
WU08	4822 323 10183	Jumper Lead, 8P
WU10	4822 323 10159	Jumper Lead, 5P
WU11	4822 323 10159	Jumper Lead, 5P
WU12	4822 323 10111	Jumper Lead, 4P
		PU24-TACT SWITCH CIRCUIT BOARD
		PU24-SEMICONDUCTORS
DM01 }	4822 130 80326	L.E.D. LT3D88
DM07		
		PU24-MISCELLANEOUS
SU03	4822 276 11559	Push Switch, Tact
SU08 }	4822 276 11559	Push Switch, Tact
SU39		
SU40	4822 276 11656	Push Switch, Tact REDLED
WU31	4822 323 10113	Jumper Lead, 5P
WU32	4822 323 10087	Jumper Lead, 4P
WU33	4822 323 10058	Jumper Lead, 6P
WU34	4822 323 10158	Jumper Lead, 8P
		PU34-TACT SWITCH CIRCUIT BOARD
SU01	4822 276 11559	Push Switch, Tact
SU02	4822 276 11559	Push Switch, Tact
SU04	4822 276 11559	Push Switch, Tact
SU05	4822 276 11559	Push Switch, Tact

REF. DESIG.	PART NO.	DESCRIPTION
		PU54-U-COM 2 CIRCUIT BOARD
		PU54-SEMICONDUCTORS
DU51 ? DU55 DU57	4822 130 33305	Diode 1SS133, etc.
QU51 QU52 QU53 QU54 QU55 QU56 QU57	4822 209 70088 4822 209 70088 4822 130 42483 4822 130 42715 4822 130 42483 4822 130 42715 4822 130 42483	IC HD14011BP IC HD14011BP Transistor 2SC536SP(F, G) Transistor 2SA608SP(F, G) Transistor 2SC536SP(F, G) Transistor 2SA608SP(F, G) Transistor 2SC536SP(F, G)
		PU54-MISCELLANEOUS
JU51 JU52	4822 265 10063 4822 265 10061	Jack, 6P Jack, 5P
WN52	4822 323 10226	Jumper Lead, 4P
		PW04-SPEAKER TERMINAL CIRCUIT BOARD
JW01 JW02 JW03 JW04	4822 267 20233 4822 266 30308 4822 264 30226 4822 265 10217	Terminal, 8P; Speaker Terminal, 4P; Speaker Plug, 2P Jack, 6P
		P604-DOLBY SURROUND CIRCUIT BOARD
		P604-CAPACITORS
C851 C852	4822 122 32486 4822 122 32486	Ceramic 0.01 μ F +80% -20% Ceramic 0.01 μ F +80% -20%
		P604-RESISTORS
R630 Δ R851 Δ R852 Δ R853	4822 100 11042 4822 116 60268 4822 116 60246 4822 116 60246	47K Ω , Trimming 680 Ω \pm 5% 2W 220 Ω \pm 5% 1W [A] 220 Ω \pm 5% 1W
		P604-SEMICONDUCTORS
DS51 ? DS56	4822 130 33305	Diode 1SS133, etc.
D601 D602	4822 130 33305 4822 130 33305	Diode 1SS133, etc. Diode 1SS133, etc.
Δ D851 Δ D852 Δ D853 Δ D854 Δ D855	4822 130 32508 4822 130 32508 4822 130 32508 4822 130 32508 4822 130 32508	Diode DSF10C, etc. Diode DSF10C, etc. [N, W] Diode DSF10C, etc. Diode DSF10C, etc. [N, W] Diode DSF10C, etc.

REF. DESIG.	PART NO.	DESCRIPTION
Δ D856 Δ D857 Δ D858	4822 130 32508 4822 130 32508 4822 130 32508	Diode DSF10C, etc. [N, W] Diode DSF10C, etc. Diode DSF10C, etc. [N, W]
D859 D860 D861 D864 D865 D866 D867	4822 130 32508 4822 130 32508 4822 130 33948 4822 130 33305 4822 130 33305 4822 130 80091 4822 130 33305	Diode DSF10C, etc. Zener RD5.6J Diode 1SS133, etc. Diode 1SS133, etc. Zener RD12J Diode 1SS133, etc.
QF01 QF02 QF03	4822 209 83631 4822 209 83631 4822 209 83631	IC NJM4558D-D IC NJM4558D-D IC NJM4558D-D
QH01 QH02	4822 209 83631 4822 209 83631	IC NJM4558D-D IC NJM4558D-D
QS51 QS52 QS53 QS54	4822 209 83804 4822 209 83804 4822 130 42715 4822 130 42483	IC LC4966 IC LC4966 Transistor 2SA608SP(F, G) Transistor 2SC536SP(F, G)
Q601 Q602 Q603 Q604 Q605	4822 209 83631 4822 209 83631 4822 209 82826 4822 209 71777 4822 209 81763	IC NJM4558D-D IC NJM4558D-D IC TA7629P IC MN3007 IC MN3101
Q852 Q853 Q854	4822 130 60839 4822 130 42483 4822 130 42715	Transistor 2SC2458(Y, GR) Transistor 2SC536SP(F, G) Transistor 2SA608SP(F, G)
JS51 J601	4822 265 10105 4822 265 10158	P604-MISCELLANEOUS Jack, 4P Plug, 2P
W602 W603 W606 W608	4822 323 10111 4822 323 10108 4822 321 21744 4822 323 10076	Jumper Lead, 4P Jumper Lead, 3P Connective Cord, 3P Jumper Lead, 3P
W851 W852	4822 323 10154 4822 323 10154	Jumper Lead, 7P Jumper Lead, 7P
		P704-POWER AMP DRIVER CIRCUIT BOARD
		P704-CAPACITORS
CN04 ? CN06	4822 122 32486	Ceramic 0.01 μ F +80% -20%
R711 R712 Δ R715 Δ R716 Δ R719 Δ R720 R731 Δ R735 Δ R739	4822 100 20524 4822 100 20524 4822 116 60314 4822 116 60314 4822 116 60314 4822 116 60314 4822 100 20524 4822 116 60314 4822 116 60314	4.7K Ω , Trimming 4.7K Ω , Trimming 10 Ω \pm 5% $\frac{1}{4}$ W, Fusible 10 Ω \pm 5% $\frac{1}{4}$ W, Fusible 10 Ω \pm 5% $\frac{1}{4}$ W, Fusible 10 Ω \pm 5% $\frac{1}{4}$ W, Fusible 4.7K Ω , Trimming 10 Ω \pm 5% $\frac{1}{4}$ W, Fusible 10 Ω \pm 5% $\frac{1}{4}$ W, Fusible

REF. DESIG.	PART NO.	DESCRIPTION
		P704-SEMICONDUCTORS
DN51	4822 130 33305	Diode 1SS133, etc.
DN52	4822 130 33305	Diode 1SS133, etc.
DN53	4822 130 33305	Diode 1SS133, etc.
DN54	4822 130 80091	Zener RD12J
QN51 }	4822 130 43818	Transistor 2SC2878(A)
QN54		
QN56	4822 130 43818	Transistor 2SC2878(A)
QN58	4822 130 43818	Transistor 2SC2878(A)
Q701	4822 209 83779	IC μ PC1270H
Q702	4822 209 83779	IC μ PC1270H
Q721	4822 209 83779	IC μ PC1270H
		P704-MISCELLANEOUS
JN51	4822 265 10105	Jack, 4P
J701	4822 265 10059	Jack, 8P
J702	4822 265 10061	Jack, 5P
J703	4822 265 10078	Plug, 3P
J704	4822 265 10078	Plug, 3P
W701	4822 323 10105	Jumper Lead, 3P
W702	4822 323 10105	Jumper Lead, 3P
W721	4822 323 10105	Jumper Lead, 3P
		P714-TRANSISTOR (L-CH) CIRCUIT BOARD
Q703	4822 130 60117	Transistor 2SC3419(Y)
		P724-TRANSISTOR (R-CH) CIRCUIT BOARD
Q704	4822 130 60117	Transistor 2SC3419(Y)
		P734-TRANSISTOR (DOLBY) CIRCUIT BOARD
Q723	4822 130 60117	Transistor 2SC3419(Y)
		P754-POWER AMP/SUPPLY CIRCUIT BOARD
		P754-CAPACITORS
C801	4822 124 21861	Elect 10000 μ F 50V
C802	4822 124 21861	Elect 10000 μ F 50V
Δ C807	4822 122 30043	Ceramic 0.01 μ F +80% -20%

REF. DESIG.	PART NO.	DESCRIPTION
		P754-RESISTORS
Δ RN07	4822 116 60314	10 Ω \pm 5% $\frac{1}{4}$ W, Fusible
Δ R751	4822 116 52332	10 Ω \pm 5% $\frac{1}{4}$ W
Δ R752	4822 116 52332	10 Ω \pm 5% $\frac{1}{4}$ W
Δ R753	4822 116 52332	10 Ω \pm 5% $\frac{1}{4}$ W
Δ R754	4822 116 52332	10 Ω \pm 5% $\frac{1}{4}$ W
Δ R755	4822 111 91402	0.1 Ω x2 3W
Δ R756	4822 111 91402	0.1 Ω x2 3W
Δ R757	4822 116 52858	4.7 Ω \pm 5% $\frac{1}{4}$ W
Δ R758	4822 116 52858	4.7 Ω \pm 5% $\frac{1}{4}$ W
Δ R759	4822 111 90726	10 Ω \pm 5% 2W
Δ R760	4822 111 90726	10 Ω \pm 5% 2W
Δ R771	4822 116 52332	10 Ω \pm 5% $\frac{1}{4}$ W
Δ R773	4822 116 52332	10 Ω \pm 5% $\frac{1}{4}$ W
Δ R775	4822 111 91402	0.1 Ω x2 3W
Δ R777	4822 116 52858	4.7 Ω \pm 5% $\frac{1}{4}$ W
Δ R779	4822 111 90726	10 Ω \pm 5% 2W
Δ R801	4822 116 60308	2.2 Ω \pm 5% $\frac{1}{4}$ W, Fusible
Δ R802	4822 116 60308	2.2 Ω \pm 5% $\frac{1}{4}$ W, Fusible
Δ R803	4822 116 60346	2.2K Ω \pm 5% 1W
Δ R804	4822 116 60346	2.2K Ω \pm 5% 1W
Δ R805	4822 116 60266	47 Ω \pm 5% 1W
Δ R806	4822 116 60266	47 Ω \pm 5% 1W
Δ R807	4822 116 60266	47 Ω \pm 5% 1W
Δ R808	4822 116 60266	47 Ω \pm 5% 1W
		P754-SEMICONDUCTORS
Δ DN01	4822 130 32508	Diode DSF10C, etc.
Δ DN02	4822 130 32508	Diode DSF10C, etc.
DN03	4822 130 33305	Diode 1SS133, etc.
DN04	4822 130 33305	Diode 1SS133, etc.
DN05	4822 130 33305	Diode 1SS133, etc.
DN07	4822 130 33305	Diode 1SS133, etc.
Δ D751	4822 130 32508	Diode DSF10C, etc.
Δ D752	4822 130 32508	Diode DSF10C, etc.
Δ D753	4822 130 32508	Diode DSF10C, etc.
Δ D754	4822 130 32508	Diode DSF10C, etc.
Δ D771	4822 130 32508	Diode DSF10C, etc.
Δ D773	4822 130 32508	Diode DSF10C, etc.
Δ D801	4822 130 33063	Diode S3V20
Δ D802	4822 130 33063	Diode S3V20
Δ D803	4822 130 33063	Diode S3V20
Δ D804	4822 130 33063	Diode S3V20
D805	4822 130 33305	Diode 1SS133, etc.
D806	4822 130 33305	Diode 1SS133, etc.
D807	4822 130 80498	Zener RD16J
D808	4822 130 80498	Zener RD16J
QN01	4822 130 42715	Transistor 2SA608SP(F, G)
QN02	4822 130 42052	Transistor 2SC2785(FF, EF)
QN03	4822 130 42483	Transistor 2SC2458, etc.
QN04	4822 130 42483	Transistor 2SC2458, etc.
QN05	4822 130 42591	Transistor 2SA1175(FF, EF)
QN07	4822 130 42052	Transistor 2SC2785(FF, EF)
QN08	4822 130 42052	Transistor 2SC2785(FF, EF)
QN09	4822 130 42052	Transistor 2SC2785(FF, EF)

REF. DESIG.	PART NO.	DESCRIPTION
Q751	4822 130 60698	Transistor 2SD1714(S, P)
Q752	4822 130 60698	Transistor 2SD1714(S, P)
Q753	4822 130 60695	Transistor 2SB1159(S, P)
Q754	4822 130 60695	Transistor 2SB1159(S, P)
Q771	4822 130 60698	Transistor 2SD1714(S, P)
Q773	4822 130 60695	Transistor 2SB1159(S, P)
Δ Q801	4822 130 42073	Transistor 2SD1265(O, P)
Δ Q802	4822 130 43023	Transistor 2SA1306(O, Y)
P754-MISCELLANEOUS		
J751	4822 265 20205	Plug, 3P
J752	4822 265 20205	Plug, 3P
J755	4822 265 10097	Jack, 3P
J801	4822 265 10062	Jack, 3P
J802	4822 265 10062	Jack, 3P
J803	4822 265 20205	Plug, 3P
J804	4822 290 40209	Terminal, Earth
J805	4822 290 40209	Terminal, Earth
L751	4822 157 51739	Coil, 1μH
L752	4822 157 51739	Coil, 1μH
L771	4822 157 51739	Coil, 1μH
W751	4822 323 10244	Jumper Lead, 8P
W771	4822 323 10238	Jumper Lead, 5P
W801	4822 323 10083	Jumper Lead, 3P

(W01-99)	Assembly and Wiring
(T01-99)	Adjustment
(X01-00)	Correction

TUNER SECTION

1. TEST EQUIPMENT REQUIRED FOR SERVICING

Item	Use
AM Signal Generator	Signal source for AM alignment
Test Loop	Use with AM signal generator
FM Signal Generator	Signal source for FM alignment
MPX Signal Generator	Stereo separation alignment and trouble shooting
Distortion Analyzer	Distortion measurements
Audio Oscillator	Sinewave and squarewave signal source
AC VTVM	Voltage measurements (AC)
Oscilloscope	Waveform analysis and trouble shooting and ASO alignment
Frequency Counter	MPX oscillator adjustment (VCO)
Circuit Tester	Trouble shooting
DC VTVM	Voltage measurements (DC)
AC Wattmeter	Monitors primary power to tuner
Line Voltmeter	Monitors potential of primary power to tuner
Variable Autotransformer (0 ~ 140V AC, 10A)	Adjusts level of primary power to tuner

2. P.W. BOARDS

As can be seen from the circuit diagram the chassis of Model ST673/ST673L consists of the following units. Each unit mounted on a printed circuit board is described within the square enclosed by a bold dotted line on the circuit diagram.

1. Tuner mounted on P.W. Board P102
2. Preset Mode mounted on P.W. Board PT02
3. Preset UP/DOWN mounted on P.W. Board PS02
4. Input Output mounted on P.W. Board PW02

3. TUNER ALIGNMENT PROCEDURES

A dummy resistor of 47 kohms must be connected across the tuner output terminals before alignment.

3.1 FM Alignment Procedures (Function switch in the "FM" position, MODE switch in the MONO position.)

1. FM RF Alignment

Step	Signal Source Connection	Signal Frequency	Indicator Connection	Set the Digital Readout Frequency	Adjust:
1	FM signal generator to FM antenna terminal (75Ω) through matching network. Set the SG RF output level so that some noise can be observed on the upper and lower side of the output waveform.	98.00 MHz	VTVM to L or R channel output (JW02, ⑨ or ⑩)	98.00 MHz	FRONT END IFT (A101: L8) for maximum output and minimum distortion.
2	FM signal generator 500μV output to FM antenna terminal (75Ω) through matching network. Modulation Level: DIN 40 kHz DEV. IHF 75 kHz DEV.	98.00 MHz	"O" center meter or DC current meter in 100 μA range (J201)	98.00 MHz	L201 (Primary) core so that the meter indicates its center or may read "O".
3	FM signal generator 500μV output to FM antenna terminal (75Ω) through matching network.	98.00 MHz	Distortion meter to L or R channel output (JW02, ⑨ or ⑩)	98.00 MHz	L201 (Secondary) core for minimum distortion.

3.2 Muting Level Alignment (Function switch in the "FM" position, MODE switch in the "AUTO STEREO" position.)

Step	Signal Source Connection	Signal Frequency	Indicator Connection	Set the Digital Readout Frequency	Adjust:
1	FM signal generator 6.3μV output to FM antenna terminal through matching network (75Ω)	98.00 MHz	VTVM to L or R channel output (JW02, ⑨ or ⑩)	98.00 MHz	Adjust R211 until output is developed.

3.3 Multiplex Alignment Procedures (Function switch in the "FM" position, MODE switch in the "AUTO STEREO" position.)

Step	Signal Source Connection	Signal Frequency	Indicator Connection	Set the Digital Readout Frequency	Adjust:
1	FM signal generator 500μV output modulated by MPX signal generator to FM antenna terminal (75Ω) through matching network. Modulation Level: DIN 40 kHz+8% Pilot DEV. IHF 67.5 kHz+9% Pilot DEV.	No modulation	Frequency counter to (J301)	98.00 MHz	R314 so that Frequency may precisely read 228.0 kHz.
2		Stereo left (1,000 Hz)	VTVM to right channel output (JW02 ⑩)		R301 for same separation in both channels.
3		Stereo right (1,000 Hz)	VTVM to left channel output (JW02 ⑨)		
4	Repeat steps 2 and 3.				
5	RF generator to FM antenna terminals through matching network (75Ω) with 500μV FM stereo signal.	Pilot only	VTVM to right and left channel output (JW02 ⑨ or ⑩)	98.00 MHz	R312 so that minimum output should be the same in both channels.

3.4 AM Alignment Procedures (Function switch in the "AM" position.)

1. AM IF Alignment

Step	Signal Source Connection	Signal Frequency	Indicator Connection	Set the Digital Readout Frequency	Adjust:
1	Sweep generator to AM Antenna Terminal.	450 kHz marker	Oscilloscope to (RA15)	—	FA01 for maximum and symmetric response.

AM RF Alignment

Step	Signal Source Connection	Signal Frequency	Indicator Connection	Set the Digital Readout Frequency	Adjust:
1	Apply the signal to the AM loop antenna from the AM signal generator using the test loop.	603 kHz (600 kHz)	VTVM to L or R channel output (JW02 ⑨ or ⑩)	603 kHz (600 kHz)	LA01 for maximum output.
2		1,404 kHz (1,400 kHz)		1,404 kHz (1,400 kHz)	CA01 for maximum output.
3	Repeat steps 1 and 2.				

AM Signal Alignment (Function switch in the "AM" position)

Step	Signal Source Connection	Signal Frequency	Indicator Connection	Set the Digital Readout Frequency	Adjust:
1	Apply a signal to the AM loop antenna from the RF generator via the test loop. 500 μ V signal	999 kHz (1000 kHz)	—	999 kHz (1000 kHz)	Adjust RA13 so that light. "TUNED"

LW RF Alignment (Function in the "LW" position) ST673L Only

Step	Signal Source Connection	Signal Frequency	Indicator Connection	Set the Digital Readout Frequency	Adjust:
1	Apply the signal to the AM loop antenna from the RF generator using the test loop.	173 kHz	VTVM to L or R channel output (JW02, ⑨ or ⑩)	173 kHz	LA03 for maximum output.
2		272 kHz		272 kHz	CA08 for maximum output.
3	Repeat steps 1 and 2 as necessary to obtain maximum sensitivity.				

4. TEST POINT AND ALIGNMENT POINTS

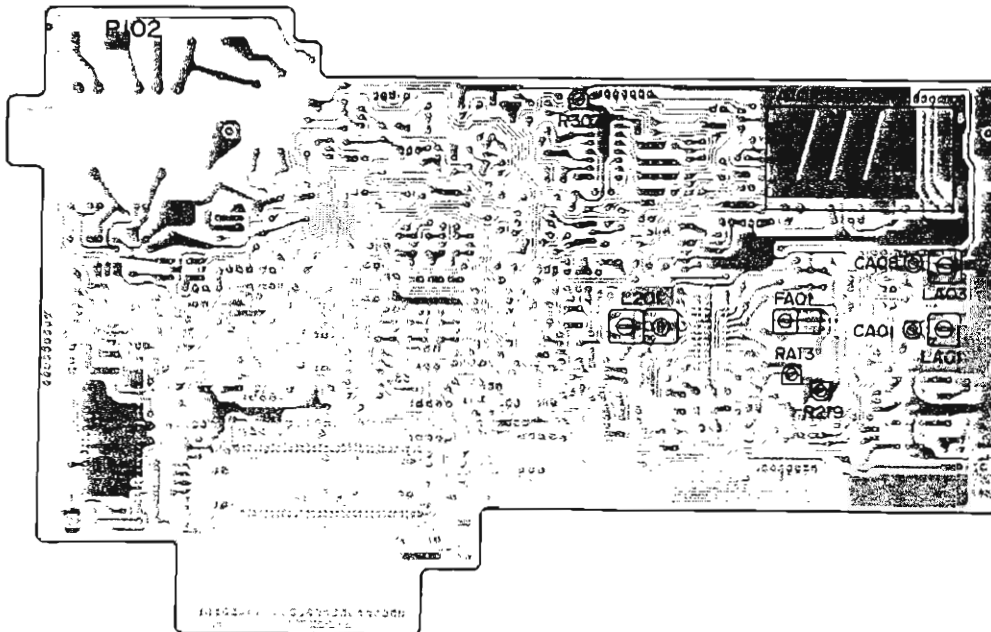

5. ONE-CHIP MICROPROCESSOR FOR TUNER-LC6514B-3357 (Q505)

1. Receiving Frequency Range, Channel Space, Reference Frequency, Intermediate Frequency

			Channel Space	Reference Frequency	Intermediate Frequency
Europe	FM	87.5 – 108.0MHz	50kHz	25kHz	+10.7MHz
	MW	531 – 1602kHz	9kHz	9kHz	+450kHz
	LW	152 – 282kHz	1kHz	1kHz	+450kHz

2. Tuning Function

- 1) Automatic Up/Down Tuning (sawtooth wave mode)
- 2) Manual Up/Down Tuning
The frequency changes in steps when the momentary switch is pressed or rapidly at a speed of approximately 70ms/step when the switch is depressed for 0.5 seconds or more. If the finger is released automatic tuning is performed.
- 3) Preset Memory Recall
16 FM stations + 8 AM stations
For FM, 8 keys x 2 = 16
M1 to M8 when keys pressed for less than 0.5 sec.
M9 to M16 when keys pressed for more than 0.5 sec.
For AM (MW + LW) – 8
M1 to M8 (random for MW and LW)

3. Remote Control Function

Remote control operation with Philips RC-5 bus code signals.

- a) Band switching
- b) Preset recall
- c) Tuning up/down
- d) Mode (mono/stereo) switching

4. Easy Bus Out Function

The signal for switching the audio amplifier's input selector to TUNER is output as an RC-5 bus code. (For band switching, preset recall, and tuning up/down)

5. IF Count Function

For the LW band only, when the SD pin becomes high after the PLL frequency is changed, the IF frequency is counted and "TUNED" lights on the fluorescent display if the result is 450 kHz. If in the auto scan mode, scanning stops. (There is no IF count function for the FM and MW bands.)

6. Key Matrix

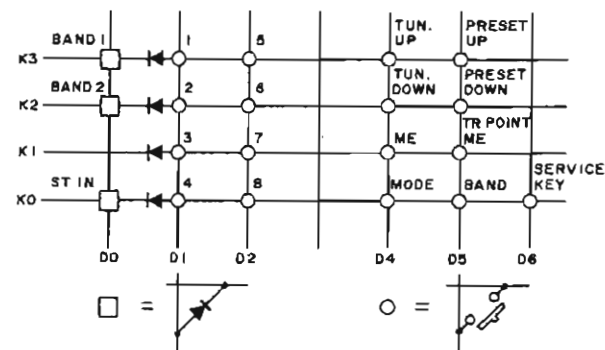

Description of Keys

- * **BAND 1**, **BAND 2** Initial setting diodes for directivity selection

	USA	JAPAN	EUROPE (w/o LW)	EUROPE (w/ LW)	
BAND 1	0	1	0	1	BAND 1: D501
BAND 2	0	0	1	1	BAND 2: D502

0: No diode
1: Diode

- * **ST IN** (Transistor switch)
Inputs PLL IC LM7000 ST. OUT. (When IF frequency becomes 450 ± 0.6 kHz, ST. OUT becomes low and transistor switch turns ON.)

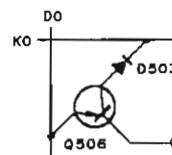

- * **1 – 8** Preset memory setting and recall keys
- * **TUNE UP**, **DOWN** Tuning up and down keys
The frequency increases or decreases by 1 step when pressed once (0.5 sec. or less) and changes continuously at a speed of approximately 70 ms/step when pressed for more than 0.5 seconds. If the finger is released, automatic tuning is performed.
- * **ME** Memory setting key
When the key is pressed, "MEMORY" will light for approximately 5 seconds indicating that memory setting is possible. If pressed again, "MEMORY" will remain lit for another 5 seconds.
For AM, the frequency is stored at that key number when any key is pressed. For FM, the frequency is stored at numbers 1 to 8 if the keys are pressed for less than 0.5 seconds, and at numbers 9 to 16 if the keys are pressed for more than 0.5 seconds.
- * **MODE** Mono/stereo output select key
When pressed in FM, the mono/stereo output changes cyclicly between low and high. This can also be stored in the memory with the preset memory frequency.

* **BAND** Band select key. Band switches each time key is pressed.



* **PRESET UP**, **DOWN** Preset scan up and down keys
The preset address increases or decreases by 1 step when pressed once (0.5 sec. or less) and changes continuously at a speed of approximately 0.5 sec/step when pressed for more than 0.5 seconds.

TR POINT ME (Tracking point memory key)

When test point J501 ① and ② on the P102 P.W. board are shorted, the following frequencies are written into the memory:

FM: P1=90.0 MHz, P2=98.0 MHz, P3=106.0 MHz

AM: P1=603 kHz, P2=999 kHz, P3=1404 kHz

P4=173 kHz, P5=209 kHz, P6=272 kHz (LW only)

SERVICE (Service program start key)

When test points D6 and K0 on the P102 P.W. board are shorted, the following service program is started;

- 1) The muting signal is output.
- 2) First all displays on the fluorescent display turn off, then the segments light in order one at a time starting from the "a" segment for the fourth digit.
- 3) After the last segment lights, all segments remain lit for approximately 3 seconds, then the unit returns to the same status as before the service program was started.

Pin Connections Diagram

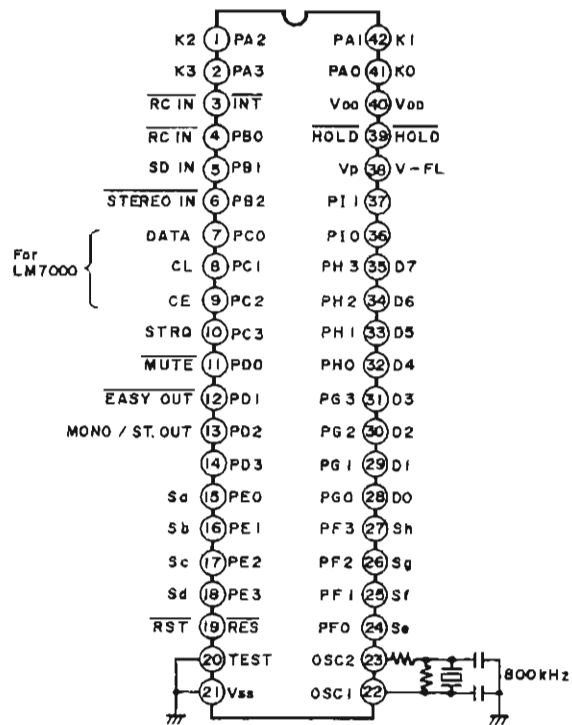

Description of Pins

- Sa – Sh: Fluorescent display segment signals.
- Do – D7: Fluorescent display digit signals and key return signals.
D0 – Diode matrix return signal
D1 – D6 – Key return signals
D1 – D7 – Digit signals
- K0 – K3: Key input, diode matrix input
- DATA }
CL } Signals transferred to LM7000N
CE }
- R.C IN: For inputting remote control signal.
- SD IN: Stop signal input pin for auto tuning.
For FM and MW, when the SD IN pin becomes high, "TUNED" lights on the fluorescent display, and if in the auto tuning mode, scanning stops.
For LW, when the SD IN pin becomes high, the STRQ pin becomes high and the LM7000N performs IF counting. If the result is 450 kHz ±0.6 kHz, ST IN becomes low, "TUNED" lights, and if in the auto tuning mode, scanning stops.
- ST RQ: Signal for making LM7000N perform IF counting.
For the LW band only, if the SD IN pin is high after the PLL data is changed, the ST RQ pin becomes high for approximately 180 ms.
- MUTE OUT: Audio mute signal.
Output when the band is switched, preset frequencies are recalled, the power is turned on, etc. Low when active.

- EASY OUT:** Easy operation out signal.
Outputs a 14-bit RC-5 code synchronized with the MUTE OUT output.
- MONO/ST. OUT:** Mode switch output.
For FM, the output changes between low and high depending on the MODE key. When the output is high, "AUTO" lights on the fluorescent display, and when low, "AUTO" is not lit.
- STEREO IN:** Pin for lighting "STEREO" on fluorescent display.
For FM, when this pin becomes low, "STEREO" lights only when "TUNED" is lit.

System Block Diagram

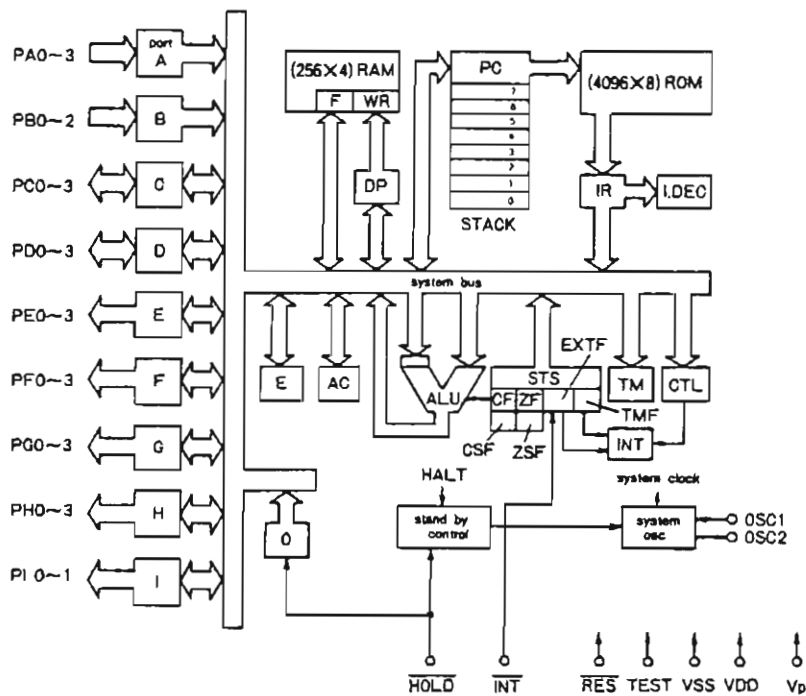

- RAM: Data Memory
- F: Flag
- WR: Working Resist
- AC: Accumulator
- ALU: Logic Operation unit
- DP: Data Pointer
- E: E Register
- CTL: Control Register
- OSC: OSC Circuit
- TM: Timer
- STS: Status Register
- ROM: Program Memory
- PC: Program Counter
- INT: Interrupt Control
- IR: Inst. Resister
- I. DEC: Inst. Decoder
- DF, CSF: Carry Flag
- ZF, ZSF: Zero Flag

7. SCHEMATIC DIAGRAM

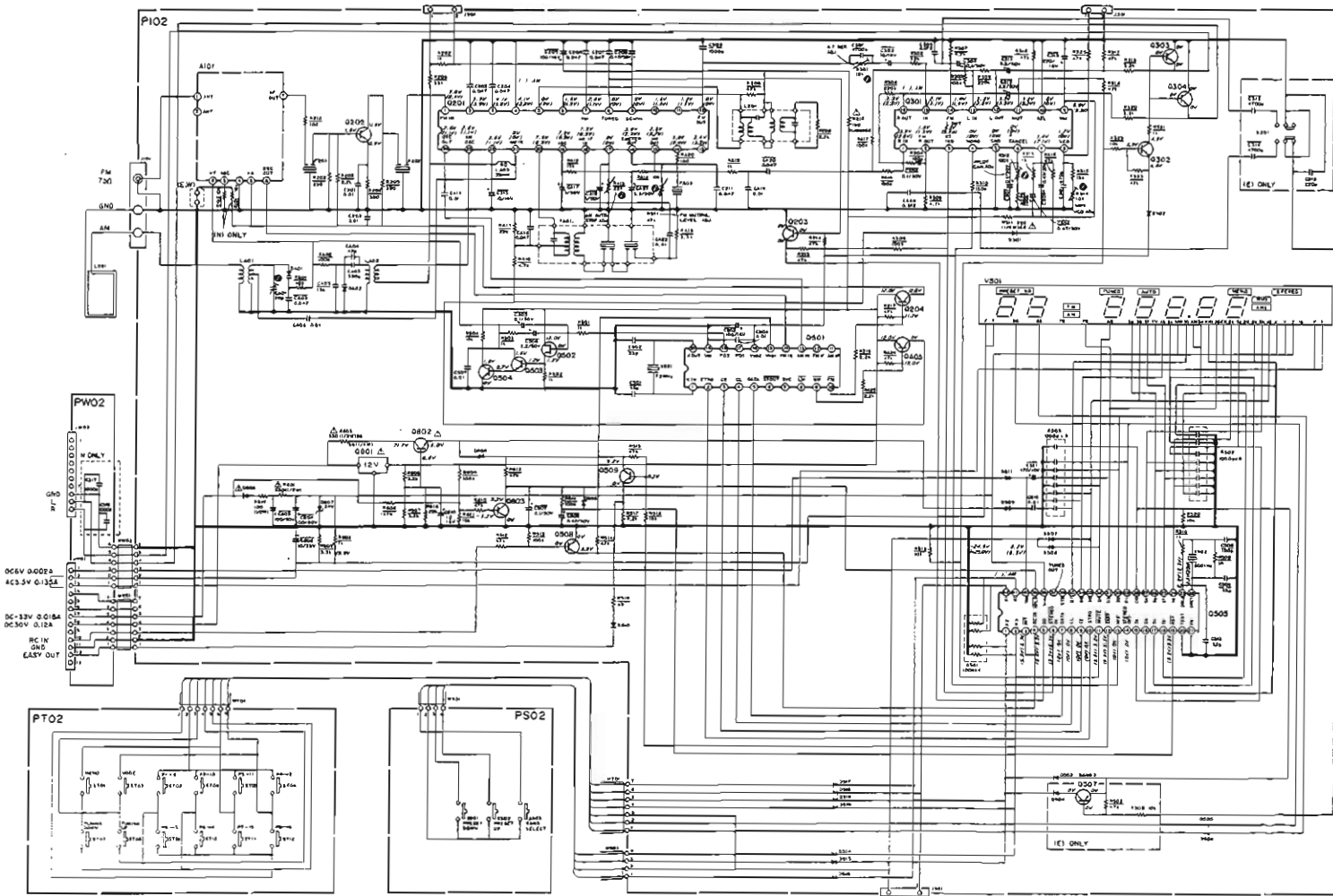

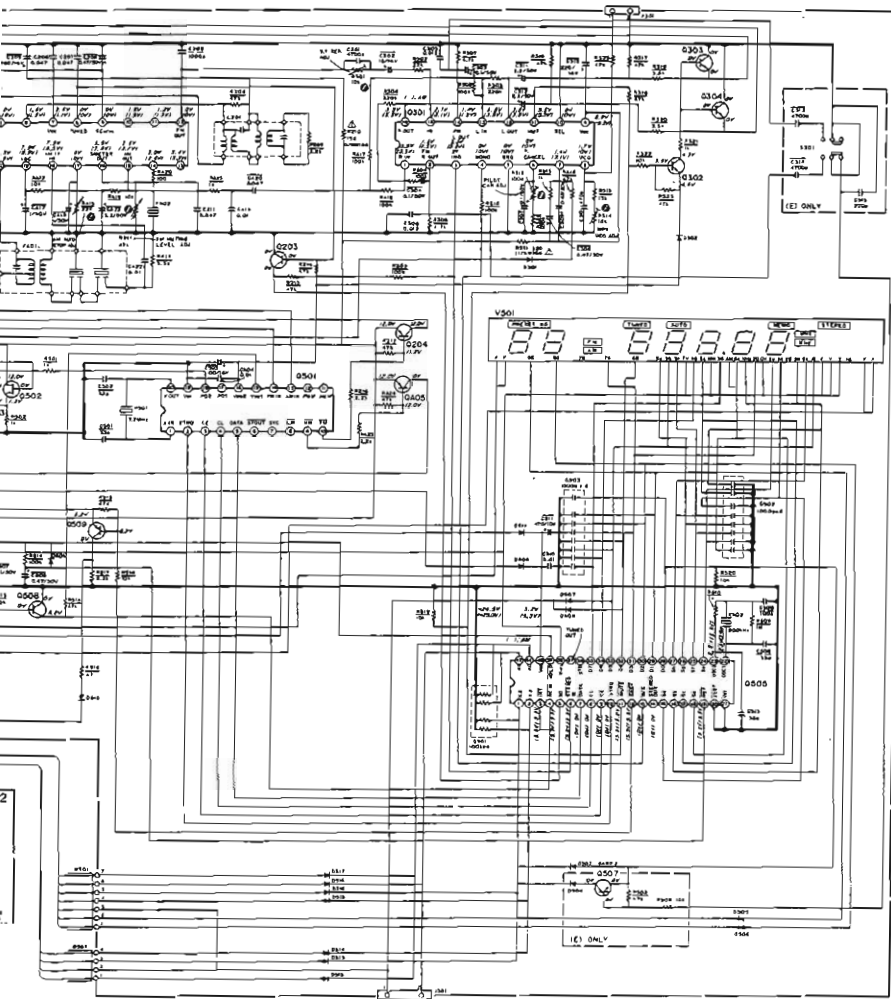

Model ST673

Q201
LA1266 FM/AM IF

Q202
Z5C1047C



Q203, Q203, Q204, Q203
Q204, Q208, Q203
Z5C336SP(F, G)
Z5C4501Y, (G)
Z5C331A, (G, R)
Z5C1740SR, (S)

Q204, Q202
4B07, Q209, Q2A05

ZM4008SP(F, G)
Z5A1048Y, (G)
Z5A130HAR, (R)
Z5A5335R, (S)

Q301
TEA5881 FM MPX

Q501
LM7000N

Q502
25X304

Q505
LC82148-3357

Q801
NJM7812A

Q802
Z0D863E

Q803
RQ24B2
MTJ240

Q801, Q802
EVC1315P

Q501 VOLTAGE

VOLTAGE	1	2	3	4	5	6	7	8	9	10
V _{CC}	5.0	5.0	5.0	5.0	5.0	5.0	5.0	5.0	5.0	5.0
V _{EE}	0.0	0.0	0.0	0.0	0.0	0.0	0.0	0.0	0.0	0.0
V _{IN}	0.0	0.0	0.0	0.0	0.0	0.0	0.0	0.0	0.0	0.0
V _{OUT}	0.0	0.0	0.0	0.0	0.0	0.0	0.0	0.0	0.0	0.0
V _{REF}	0.0	0.0	0.0	0.0	0.0	0.0	0.0	0.0	0.0	0.0
V _{TEST}	0.0	0.0	0.0	0.0	0.0	0.0	0.0	0.0	0.0	0.0

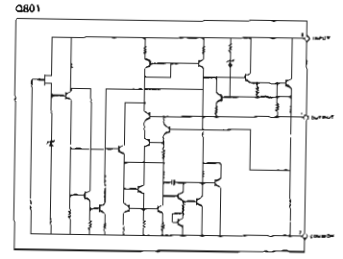
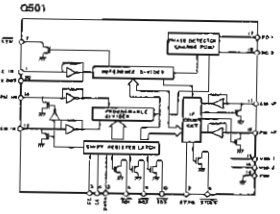
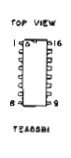
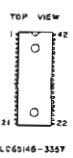
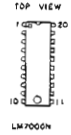
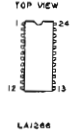
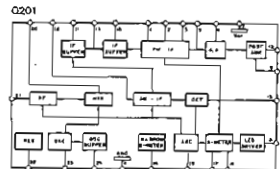
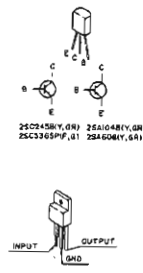

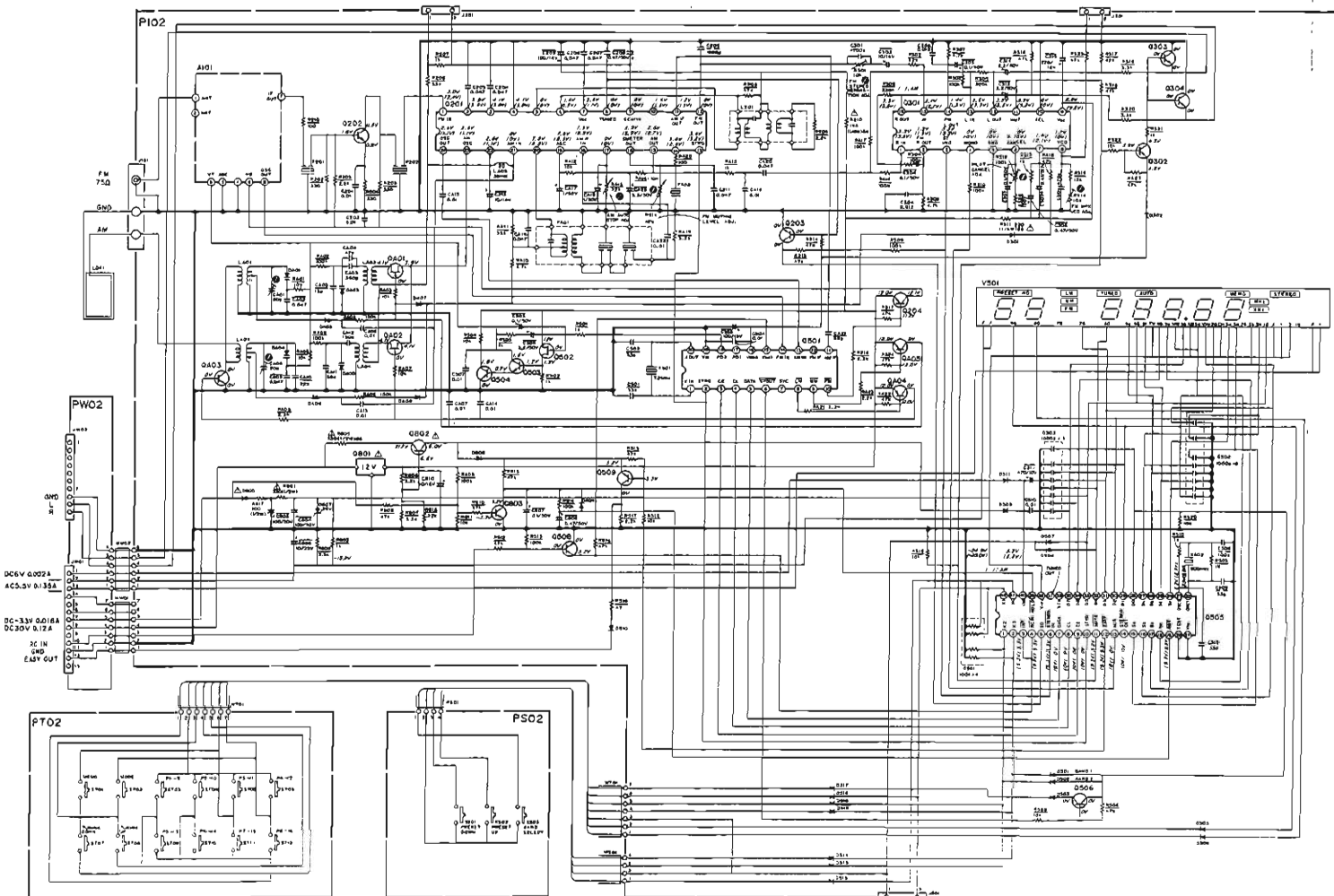

- Q201
- LA1256
- Q202
- 2SC1047
- Q203, Q3
- Q800, Q8
- 2SC536
- 2SC245
- 2SC331
- 2SC1740
- Q204, Q3
- Q509, Q8
- 2SA6096
- 2SA1748
- 2SA1308
- 2SA9339
- Q301
- TEA5681
- Q301
- LM7000
- Q802
- 29083E
- Q506
- LC6248
- Q801
- NJM7812
- Q401, QAC
- 25V30M
- Q403
- 250302
- Q501, Q30
- Q502 - 55
- 2A07, QAC
- 15S13.16
- Q803, Q80
- RL03E, Q5
- Q807
- R604-Q82
- MF124D
- Q403, QAC
- 15S13D
- Q501 V0

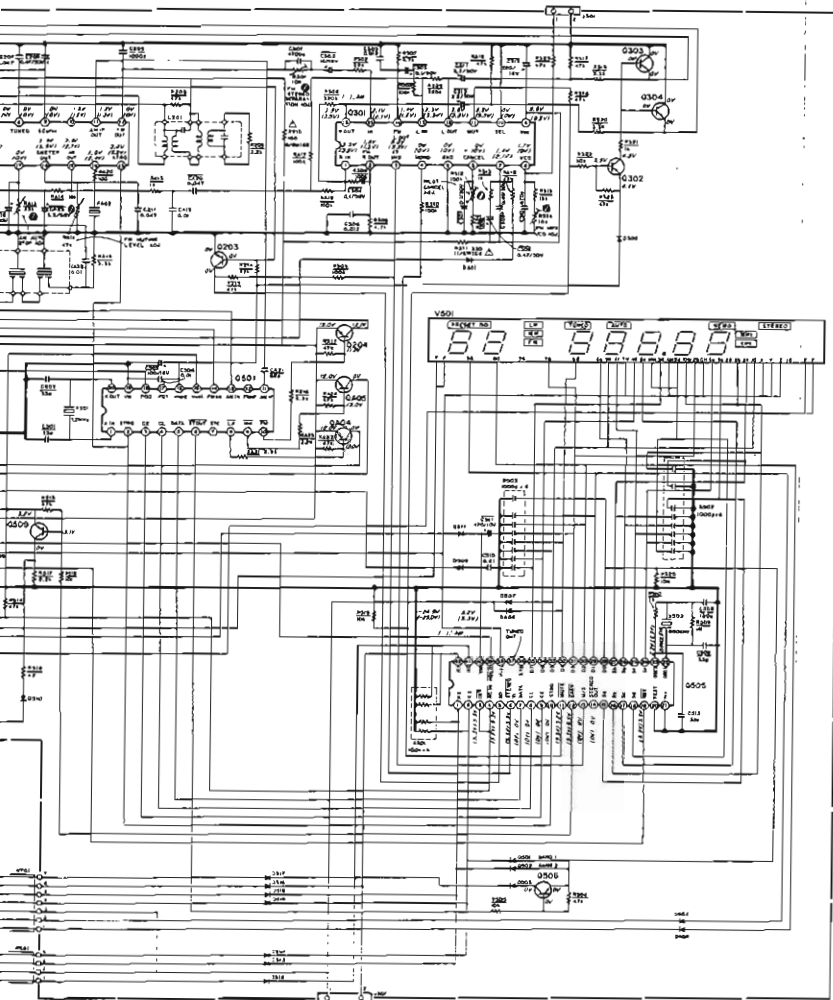

Model ST673L

Q201 LA1266 FM/AM IF

Q202 2SC1047C

Q203, Q303, Q304, Q403
Q504, Q508, Q503
2SC3365P (P, S)
2SC2458Y (Y, BR)
2SC33181G (G)
2SC174051R (S)

Q204, Q302, Q506
Q509, Q404, Q405

2BA6085P (P, S)
2SA1048Y (Y, BR)
2SA1309A (A, S)
2SA9335P (P, S)

Q301 TEA591 FM MPX

Q501 LM7000

Q302 2SD1043E

Q503 LC6514B-3357

Q801 NJM7812A

Q401, Q402, Q502 2SK304Y (Y)

Q403 2SD1302 (S, T)

Q505, Q509, Q501 ~ Q505
Q506 ~ Q511, Q513 ~ Q515
Q407, Q408
1SS133, 1SS176, MA16S

Q606, Q808, Q609

RL103K, DSF 10C

D807

ROM-JR2 MTJ214D

Q401, Q402, Q404, Q405

5VC521EP

DA03, DA06

1SS135

Q501	VOLTAGE
C	+5V
1	+5V
2	+5V
3	+5V
4	+5V
5	+5V
6	+5V
7	+5V
8	+5V
9	+5V
10	+5V
11	+5V
12	+5V
13	+5V
14	+5V
15	+5V
16	+5V
17	+5V
18	+5V
19	+5V
20	+5V
21	+5V
22	+5V
23	+5V
24	+5V
25	+5V
26	+5V
27	+5V
28	+5V
29	+5V
30	+5V
31	+5V
32	+5V
33	+5V
34	+5V
35	+5V
36	+5V
37	+5V
38	+5V
39	+5V
40	+5V
41	+5V
42	+5V
43	+5V
44	+5V
45	+5V
46	+5V
47	+5V
48	+5V
49	+5V
50	+5V
51	+5V
52	+5V
53	+5V
54	+5V
55	+5V
56	+5V
57	+5V
58	+5V
59	+5V
60	+5V
61	+5V
62	+5V
63	+5V
64	+5V
65	+5V
66	+5V
67	+5V
68	+5V
69	+5V
70	+5V
71	+5V
72	+5V
73	+5V
74	+5V
75	+5V
76	+5V
77	+5V
78	+5V
79	+5V
80	+5V
81	+5V
82	+5V
83	+5V
84	+5V
85	+5V
86	+5V
87	+5V
88	+5V
89	+5V
90	+5V
91	+5V
92	+5V
93	+5V
94	+5V
95	+5V
96	+5V
97	+5V
98	+5V
99	+5V
100	+5V

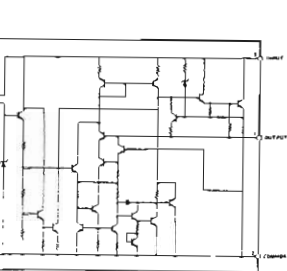
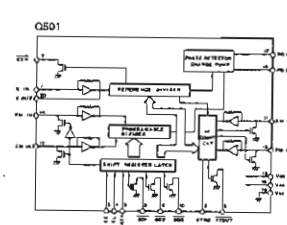
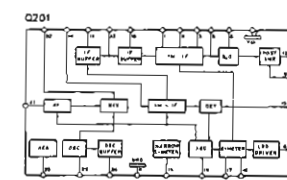
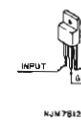
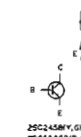
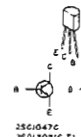

8. COMPONENT LOCATIONS

Tuner (P102)

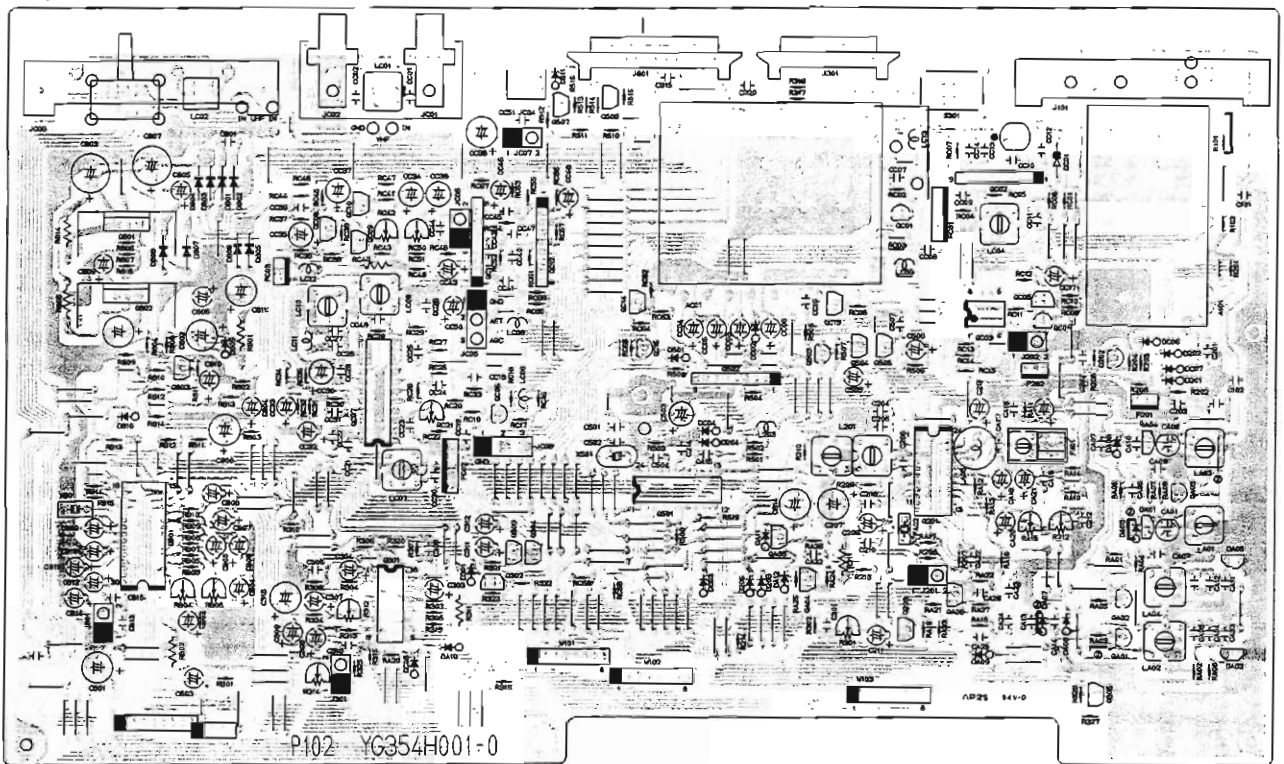

Preset Mode (PT02)

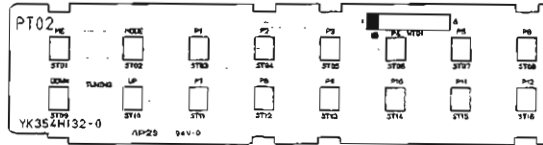

Input Output (P)



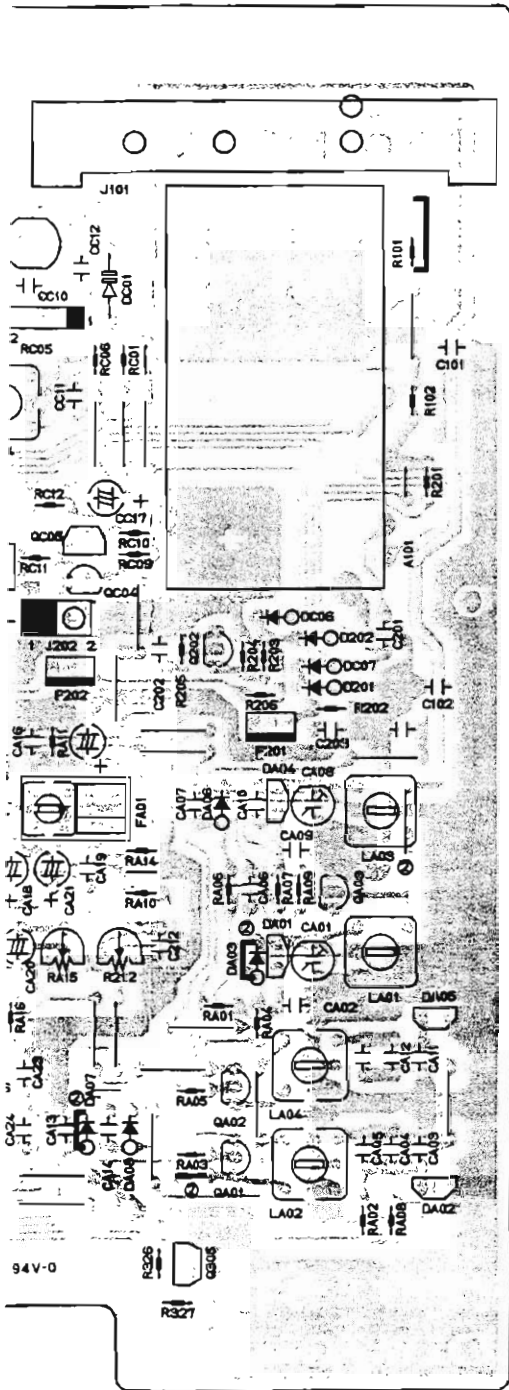

Input Output (PW02)

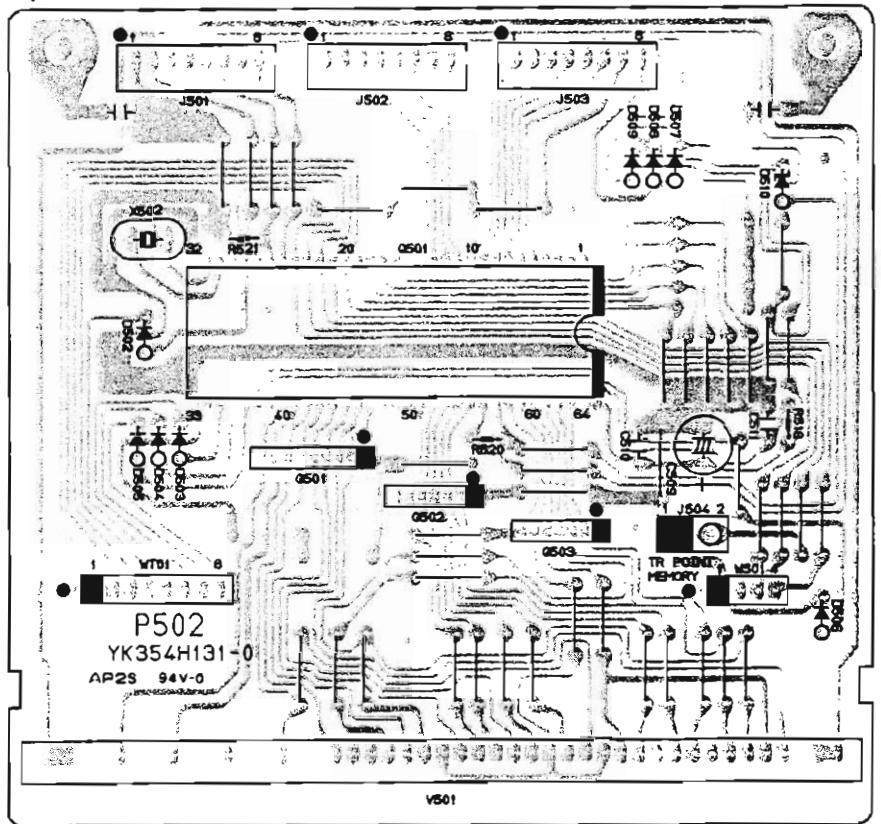

Preset UP/DOWN (PS02)

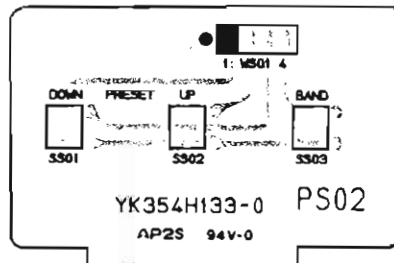

9. EXPLODED VIEW AND PARTS LIST

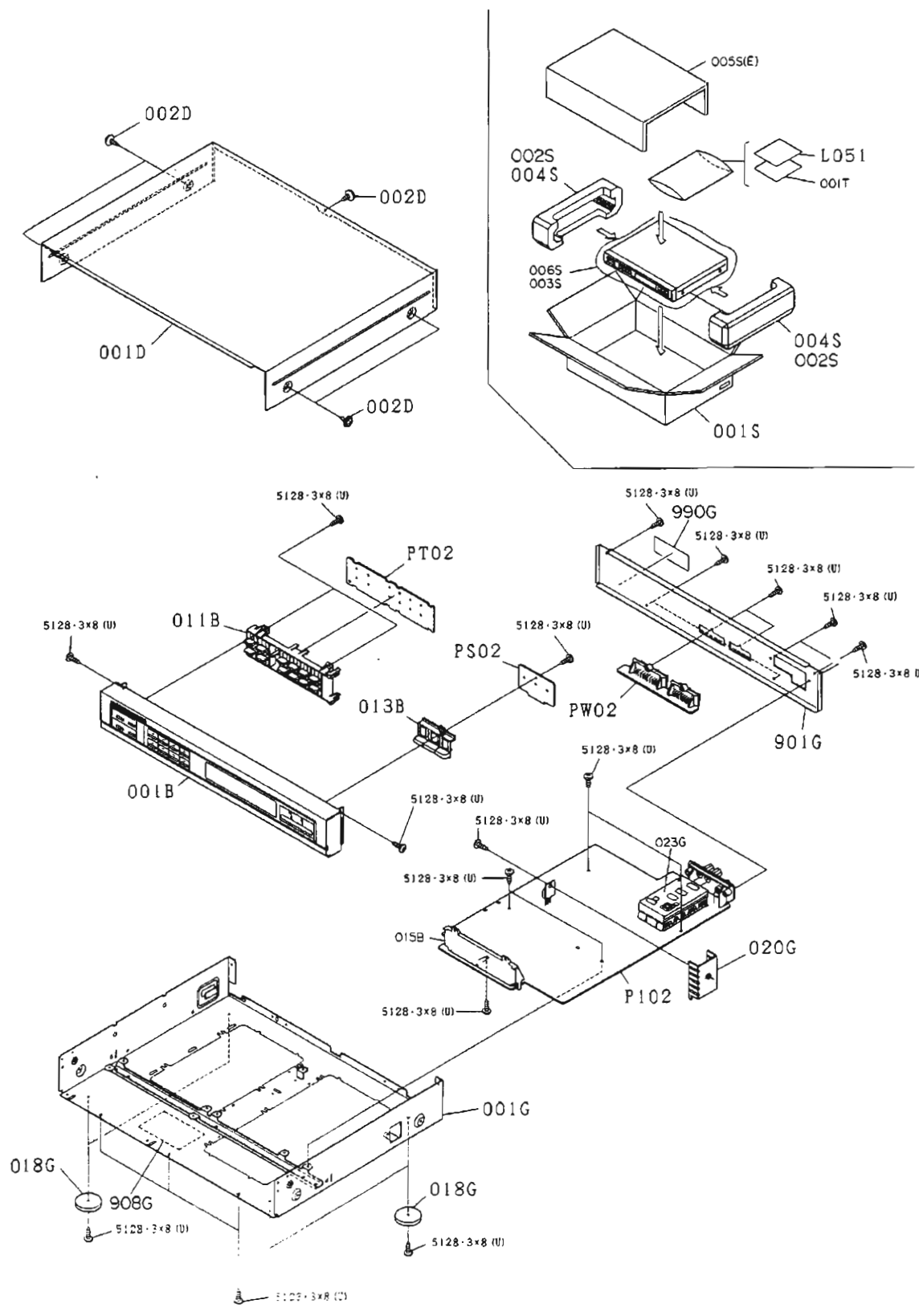

REF. DESIG.	PART NO.	DESCRIPTION
001B	4822 426 51189	Front Panel Assembly (ST673)
	4822 426 51208	Front Panel Assembly (ST673L)
011B	4822 410 25817	Button, Preset
013B	4822 410 25831	Button, Tuning Up/Down
001D	4822 426 40368	Lid, Top Cover
002D	4822 502 12355	B.T. Screw 83 x 8
018G	4822 462 41143	Leg
020G	4822 255 40532	Heatsink
901G	4822 426 20135	Rear Panel (ST673) [N]
	4822 426 20136	Rear Panel (ST673) [E]
	4822 426 20117	Rear Panel (ST673) [W]
	4822 426 20149	Rear Panel (ST673L)
908G	4822 600 70229	Label, Caution
990G	4822 454 11873	Indicator, Made in Japan (ST673L)

REF. DESIG.	PART NO.	DESCRIPTION
		PACKING
001S	4822 600 70471	Packing Case (ST673) [N, W]
002S	4822 600 70474	Cushion (ST673L)
004S	4822 600 70474	Cushion (ST673)
L051	4822 157 53089	Antenna Coil, Loop

10. ELECTRICAL PARTS LIST

ASSIGNMENT OF COMMON PARTS CODES.

RESISTOR

R*:** (1) GD05 --- 140, Carbon film fixed resistor, $\pm 5\%$, 1/4W

R*:** (2) GD05 --- 160, Carbon film fixed resistor, $\pm 5\%$, 1/6W

① — Resistance value

Examples

① Resistance value

0.1 Ω ...001	10 Ω ...100	1k Ω ...102	100k Ω ...104
0.5 Ω ...005	18 Ω ...180	2.7k Ω ...272	680k Ω ...684
1 Ω ...010	100 Ω ...101	10k Ω ...103	1Mk Ω ...105
6.8 Ω ...068	390 Ω ...391	22k Ω ...223	4.7Mk Ω ...475

(Note) Please distinguish 1/4W from 1/6W by the shape of parts used actually.

C***: CERAMIC CAP.

(1) DD1 --- 370, Ceramic condenser
Disc type
Temp. coeff. P350 ~ N1000, 50V

①②

Capacity value
Tolerance

Examples

① Tolerance (Capacity deviation)

$\pm 0.25\text{pF}$...0
 $\pm 0.5\text{pF}$...1
 $\pm 5\%$...5

* Tolerance of COMMON PARTS handled here are as follows:

0.5pF ~ 5pF... $\pm 0.25\text{pF}$

6pF ~ 10pF... $\pm 0.5\text{pF}$

12pF ~ 560pF... $\pm 5\%$

② Capacity value

0.5pF...005 3pF...030 100pF...101
1pF...010 10pF...100 220pF...221
1.5pF...015 47pF...470 560pF...561

C***: CERAMIC CAP.

(1) DK16 --- 300, High dielectric constant ceramic condenser
Disc type
Temp. chara. 2B4, 50V

①

Capacity value

Example

② Capacity value

100pF...101 1000pF...102 10000pF...103
470pF...471 2200pF...222

C***: ELECTROLY CAP. (---), FILM CAP. (---)

(1) EA --- 10, Electrolytic condenser
One-way lead type, Tolerance $\pm 20\%$

①②

Dielectric strength
Capacity value

Examples

① Capacity value

0.1 μF ...104 4.7 μF ...475 100 μF ...107
0.33 μF ...334 10 μF ...106 330 μF ...337
1 μF ...105 22 μF ...226 1100 μF ...108
2200 μF ...228

② Working voltage

6.3V...006 25V...025
10V...010 35V...035
16V...016 50V...050

(2) DF15 --- 350, Plastic film condenser
One-way type, Mylar $\pm 5\%$ 50V

①

Capacity value

Examples

① Capacity value

0.001 μF (1000pF)...102 0.1 μF ...104
0.0018 μF ...182 0.56 μF ...564
0.01 μF ...103 1 μF ...105
0.015 μF ...153

REF. DESIG.	PART NO.	DESCRIPTION
P102-TUNER CIRCUIT BOARD		
P102-CAPACITORS		
CA01	4822 125 60104	Trimming 20pF
CA04	4822 122 31205	Ceramic 47pF $\pm 5\%$
CA05	4822 121 42466	Film 390pF $\pm 5\%$
CA06	4822 122 32486	Ceramic 0.01 μF +80% -20%
CA07	4822 122 32486	Ceramic 0.01 μF +80% -20%
CA08	4822 125 60104	Trimming 20pF (ST673L)
CA12	4822 122 10367	Ceramic 150pF $\pm 5\%$ (ST673L)
CA13	4822 122 32486	Ceramic 0.01 μF +80% -20% (ST673L)
CA14	4822 122 32486	Ceramic 0.01 μF +80% -20% (ST673L)
CA15	4822 122 32486	Ceramic 0.01 μF +80% -20%
CA16	4822 122 40306	Ceramic 0.047 μF +80% -20%
CA19	4822 122 32486	Ceramic 0.01 μF +80% -20%
CA22	4822 122 32486	Ceramic 0.01 μF +80% -20%
C201	4822 122 32486	Ceramic 0.01 μF +80% -20%
C202	4822 122 32486	Ceramic 0.01 μF +80% -20%
C203	4822 122 40306	Ceramic 0.047 μF +80% -20%
C204	4822 122 40306	Ceramic 0.047 μF +80% -20%
C206	4822 122 40306	Ceramic 0.047 μF +80% -20%
C207	4822 122 40306	Ceramic 0.047 μF +80% -20%
C211	4822 122 40306	Ceramic 0.047 μF +80% -20%
C310	4822 121 41626	Film 470pF $\pm 5\%$
C504	4822 122 32486	Ceramic 0.01 μF $\pm 5\%$
C507	4822 122 32486	Ceramic 0.01 μF +80% -20%
C510	4822 122 32486	Ceramic 0.01 μF +80% -20%
C512	4822 122 32486	Ceramic 0.01 μF +80% -20%
C801	4822 122 32827	Ceramic 4700pF +80% -20%
G502	4822 111 91393	Alloy 1000pFx8
G503	4822 111 91393	Alloy 1000pFx8
P102-RESISTORS		
RA13	4822 100 20545	22K Ω , Trimming
R210	4822 111 91404	150 Ω $\pm 5\%$ 1/6W
R211	4822 100 11042	47K Ω , Trimming
R301	4822 100 11041	10K Ω , Trimming
R311	4822 111 91405	220 Ω $\pm 5\%$ 1/6W
R312	4822 100 20552	100K Ω , Trimming
R314	4822 100 11041	10K Ω , Trimming
R801	4822 116 52846	150 Ω $\pm 5\%$ 1/8W
R804	4822 111 90724	330 Ω $\pm 5\%$ 1/8W
G501	4822 111 91399	100K Ω x4 $\pm 5\%$ 1/6W, Alloy
P102-SEMICONDUCTORS		
DA01	4822 130 31542	Varicap SVC3215F
DA02	4822 130 31542	Varicap SVC3215F
DA03	4822 130 33697	Diode 1SS135 (ST673L)
DA04	4822 130 31542	Varicap SVC3215F (ST673L)
DA05	4822 130 31542	Varicap SVC3215F (ST673L)
DA06	4822 130 33697	Diode 1SS135 (ST673L)
DA07	4822 130 33305	Diode 1SS133, etc. (ST673L)
DA08	4822 130 33305	Diode 1SS133, etc. (ST673L)

REF. DESIG.	PART NO.	DESCRIPTION
D301	4822 130 33305	Diode 1SS133, etc.
D302	4822 130 33305	Diode 1SS133, etc.
D501	4822 130 33305	Diode 1SS133, etc. (ST673L)
D502	4822 130 33305	Diode 1SS133, etc. (N, W)
D503	4822 130 33305	Diode 1SS133, etc.
D504	4822 130 33305	Diode 1SS133, etc. (ST673)(E)
D506	4822 130 33305	Diode 1SS133, etc.
D511		
D513	4822 130 33305	Diode 1SS133, etc.
D519		
D801	4822 130 32508	Diode DSF10C, etc.
D806		
D807	4822 130 80116	Zener 24V
D808	4822 130 33305	Diode 1SS133, etc.
D809	4822 130 33305	Diode 1SS133, etc.
QA01	4822 130 42121	F.E.T. 2SK30A(Y) (ST673L)
QA02	4822 130 42121	F.E.T. 2SK30A(Y) (ST673L)
QA03	4822 130 42125	Transistor 2SD1302(S, T) (ST673L)
QA04	4822 130 42715	Transistor 2SA608SP(F, G) (ST673L)
QA05	4822 130 42715	Transistor 2SA608SP(F, G)
Q201	4822 209 71785	IC LA1266
Q202	4822 130 42082	Transistor 2SC1047(C)
Q203	4822 130 42483	Transistor 2SC536SP(F, G), etc.
Q204	4822 130 42715	Transistor 2SA608SP(F, G), etc.
Q301	4822 209 71776	IC TEA5581
Q302	4822 130 42715	Transistor 2SA608SP(F, G), etc.
Q303	4822 130 42483	Transistor 2SC536SP(F, G), etc.
Q304	4822 130 42483	Transistor 2SC536SP(F, G), etc.
Q501	4822 209 83314	IC LM7000N
Q502	4822 130 42121	F.E.T. 2SK30A(Y)
Q503	4822 130 42483	Transistor 2SC536SP(F, G), etc.
Q504	4822 130 42483	Transistor 2SC536SP(F, G), etc.
Q505	4822 209 71788	Microprocessor LC8514B-3357
Q506	4822 130 42715	Transistor 2SA608SP(F, G), etc. (ST673L)
Q507	4822 130 42715	Transistor 2SA608SP(F, G), etc. (ST673) [E]
Q508	4822 130 42483	Transistor 2SC536SP(F, G), etc.
Q509	4822 130 42715	Transistor 2SA608SP(F, G), etc.
Q801	4822 209 70084	IC NJM7812A
Q802	4822 130 60173	Transistor 2SC2060(Q, R)
Q803	4822 130 42483	Transistor 2SC536SP(F, G), etc.
A101	4822 210 10246	P102-MISCELLANEOUS V.H.F. Tuner, FE306-A14 (ST673) [E W]
	4822 210 10267	V.H.F. Tuner, FE307-G44 (ST673)(N)
	4822 210 10246	V.H.F. Tuner, FE306-A14 (ST673L)
FA01	4822 242 71509	Ceramic Filter, SFL450J3
FA02	4822 242 71217	Ceramic Filter, BFU450C
F201	4822 242 71135	Ceramic Filter, SFE10.7MS3-A [N, W]
	4822 242 70911	Ceramic Filter, SFE10.7MA8-A (ST673) [E]
F202	4822 242 71135	Ceramic Filter, SFE10.7MS3-A

REF. DESIG.	PART NO.	DESCRIPTION
J101	4822 266 30298	Terminal, FM Pal
J201	4822 265 10158	Plug, 2P
J301	4822 265 10158	Plug, 2P
J501	4822 265 10158	Plug, 2P
LA01	4822 157 52328	Antenna Coil, MW
LA02	4822 157 52716	OSC Coil, MW
LA03	4822 157 52714	Antenna Coil, LW (ST673L)
LA04	4822 157 52717	OSC Coil, LW (ST673L)
LA05	4822 152 20595	Choke Coil, 39mH
L201	4822 157 52715	I.F.T. Coil, FM DET
S301	4822 277 20968	Slide Switch, Scan/Step (ST673) [E]
V501	4822 130 90433	Display Unit, FIP10TM8
X501	4822 242 71219	Crystal, 7.2MHz
X502	4822 242 71405	Ceramic Vibrator, CS8800K
PS02-PRESET UP/DOWN CIRCUIT BOARD		
SS01	4822 276 11559	Push Switch, Preset Up
SS02	4822 276 11559	Push Switch, Preset Down
SS03	4822 276 11559	Push Switch, Band
WS01	4822 323 10111	Jumper Lead, 4P
PT02-PRESET MODE CIRCUIT BOARD		
ST01	4822 276 11559	Push Switch, Preset Mode
ST12		
WT01	4822 323 10059	Jumper Lead, 7P
PW02-INPUT/OUTPUT CIRCUIT BOARD		
JW01	4822 266 30306	Terminal, 13P
JW02	4822 266 30305	Terminal, 10P
WW01	4822 323 10157	Jumper Lead, 7P
WW02	4822 323 10096	Jumper Lead, 6P

(W01-99)	Assembly and Wiring
(T01-99)	Adjustment
(X01-00)	Correction

DECK SECTION

1. P.W. BOARDS

As can be seen from the circuit diagram, the chassis of your Cassette Deck consists of the following units. Each unit mounted on a printed circuit board is described within the square enclosed by a bold dotted line on the circuit diagram.

1. Dolby B/C mounted on P.W. Board P603
2. Audio mounted on P.W. Board PJ03
3. NR Switch/
Mix Mic Amp. mounted on P.W. Board PJ23
4. Wire Connect mounted on P.W. Board PS03
5. Key Switch QMS/
Memory mounted on P.W. Board PS13
6. Key Switch Dubb./
Continuos mounted on P.W. Board PS23
7. Logic mounted on P.W. Board PU03
8. Multi Connection mounted on P.W. Board PU53
9. Regulator mounted on P.W. Board PU73
10. Key Switch LED
Indicator mounted on P.W. Board PY03
11. Cassette LED M-1 mounted on P.W. Board PY13
12. Cassette LED M-2 mounted on P.W. Board PY23
13. Connect mounted on P.W. Board PY33

2. TEST EQUIPMENT REQUIRED FOR SERVICING

For measuring or checking your Cassette Deck, the following instruments and materials are necessary.

- VTVM
- Audio Oscillator (AF OSC)
- Attenuator (600 Ω)
- Oscilloscope
- Bandpass Filter (1 kHz)
- IEC A-Curve Filter
- Wow and Flutter Meter
- Torque Meter (Cassette Type)
- Digital Frequency Counter
- Distortion Meter
- Black Tapes (Completely erased with bulk eraser)
 - TDK AC-212 (Normal)
 - TDK AC-512 (Special/CrO₂)
 - TDK AC-712 (Metal)

NOTE:

If any doubt is noted in a measured value, use new tape.

- Test tape (New Tape)

TCC-111•MTT-111	Wow and Flutter, Tape Speed
TCC-140•MTT-112B	Signal-toNoise Ratio
TCC-130•MTT-150	Level Adjustment
TCC-161•MTT-256	Frequency Response (for Normal)
TCC-261•MTT-356	Frequency Response (for CrO ₂ and Metal)
TCC-192•MTT-121	Cross Talk
TCC-194•MTT-141	Channel Separation
TCC-120 MTT-212	Output

(A-BEX)•(TEAC)

3. OPERATIONAL DESCRIPTIONS OF AUDIO AND PERIPHERAL CIRCUITS

3.1 Playback Equalizer Amp and Bias Oscillator IC TDA1600

3.1.1 Built-in circuit of IC and features (Refer to Fig. 1)

- (1) PB EQ amp: Playback equalizer circuit including rec/play head switching and $120 \mu/70 \mu$ sec time constant switching circuits.
- (2) Bias OSC: Tape bias oscillator circuit including CrO_2 /Metal indication switching circuit and Normal/ CrO_2 /Metal shift function.

3.1.2 Block diagram

Figure 1 shows the block diagram incorporating TDA1600.

- (1) Each switching operation is performed by an electronic switching method and the input conditions are as follows:

Pin ③ Tape Selector: (Normal) V+, (CrO_2) V/2, (Metal) V-,
 Pin ⑩ Rec/Play: (Play) V-, (Rec) V+

- (2) This IC operates as a DC 15 V single power supply, however, since the audio circuit ground is fixed at 1/2 V, it functions as a ± 7.5 V dual-power supply externally.

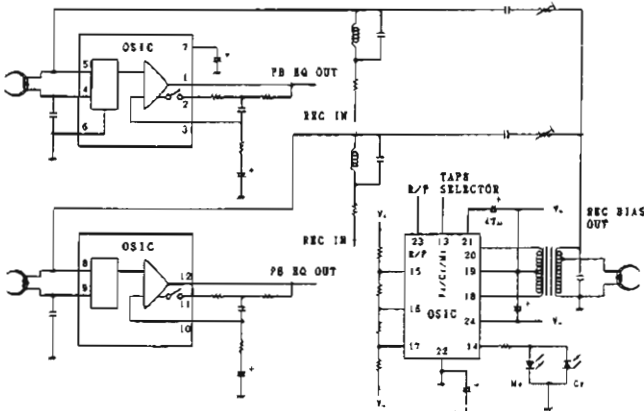
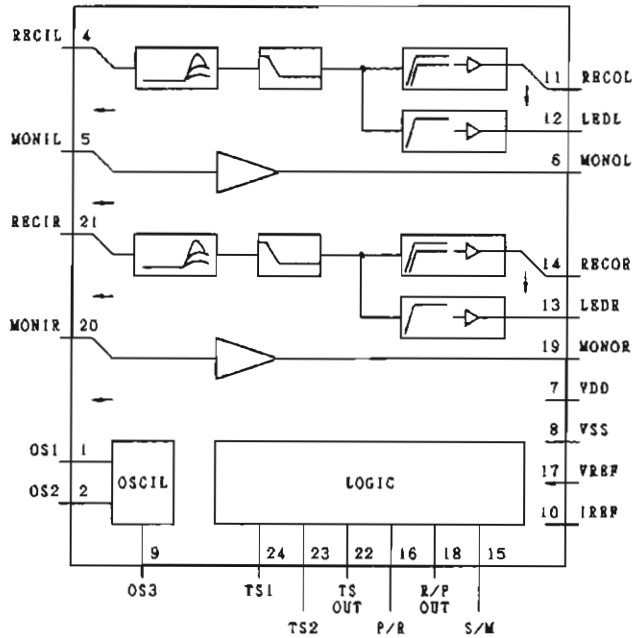

Figure 1

3.2 Recording Equalizer Amp IC TDD1601

3.2.1 Built-in circuit of IC and features

Figure 2 shows the internal construction of IC and pin connections.



PIN	SIGNAL	DEFINITION
1	OS1	Oscillator input
2	OS2	Oscillator output
3	N.C.	
4	RECIL	Recording path input left channel
5	MONIL	Monitor path input left channel
6	MONOL	Monitor path output left channel
7	VDD	Highest power supply
8	VSS	Lowest power supply
9	OS3	Oscillator control
10	IREF	Current adjustment
11	RECOL	Recording path output left channel
12	LEDL	Ledbar output left channel
13	LEDR	Ledbar output right channel
14	RECOR	Recording path output right channel
15	S/M	Signal/mute input
16	P/R	Playback/record selection input
17	VREF	AC ground
18	R/P OUT	Record/playback selection output
19	MONOR	Monitor path output right channel
20	MONIR	Monitor path input right channel
21	RECIR	Recording path input right channel
22	TS OUT	Tape selection output
23	TS2	Tape selection input 2
24	TS1	Tape selection input 1

Figure 2

(1) Rec EQ Amp: Recording equalizer amp using the switched capacitor method, and its compensation levels conform to IEC standard tapes. The peak frequency is determined by the clock frequency and shifted to each tape type programmably.

	Normal (500kHz)	High-Speed (500kHz) Dubbing (OS3 ⁺ H ^r)
Normal	17.5kHz	34.0kHz
CrO ₂	18.5kHz	36.0kHz
Metal	19.5kHz	40.0kHz

(Table 1)

(2) Monitor Path: By passing through this IC as a line output path, pop noise on Rec/play switching will be reduced.

(3) Electrical Switching: Rec/play and Tape Selector switching signals are output for IC internal switching and the switching between two TDA1600s, by each Rec/play, Tape Selector and Play Back Mute input. The input signals correspond to V- to V- +5 V for mechanism logic, and output signals are shifted to V- to V+ level to perform electronic switching.

3.2.2 Circuit configuration (Block diagram)

Figure 3 shows the simplified block diagram of TDA1600, TDD1601 and TEA0665 (Dolby NR IC).

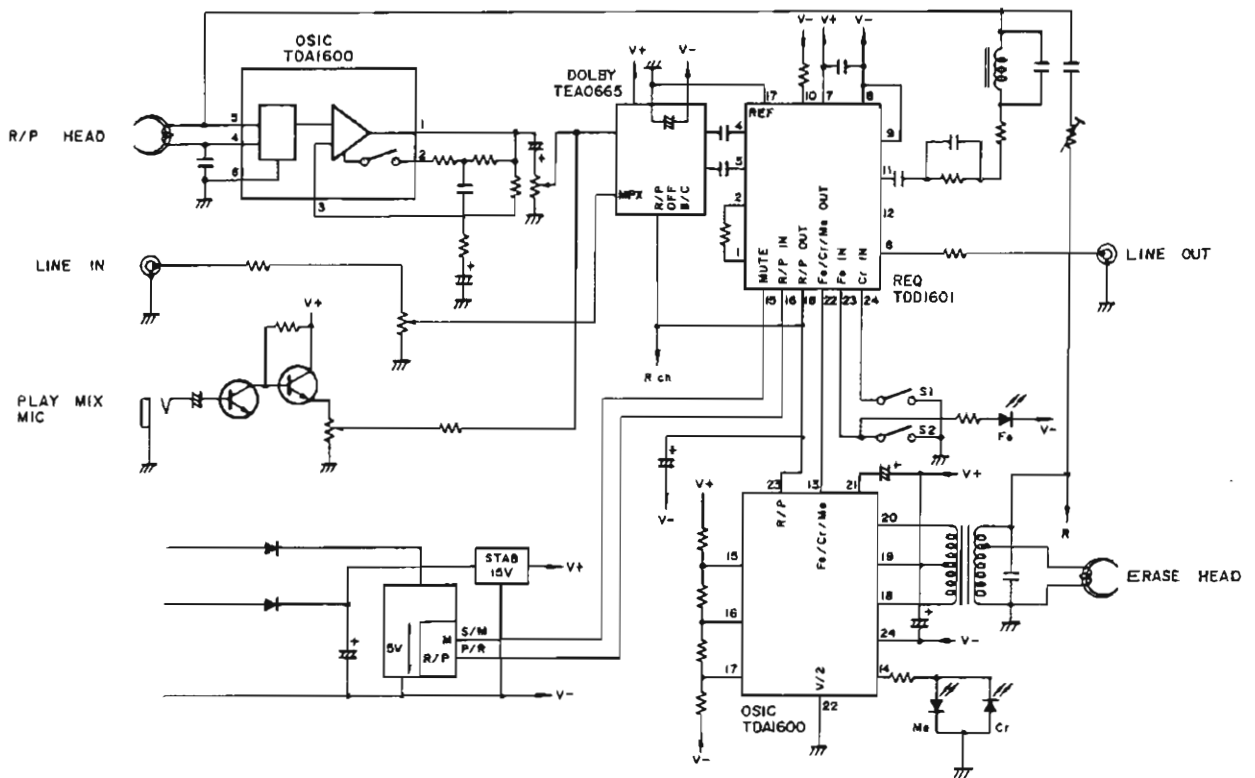

Figure 3

4. OPERATIONAL DESCRIPTION OF MICROPROCESSOR AND ITS PERIPHERAL CIRCUITS

4.1 Mechanism of This Unit

The rotational energy of the flywheel operates the head chassis movement, head rotation, braking, etc. A plunger is used to eliminate flywheel energy, so, when the mechanism is switched, pulse voltage is applied to the capstan motor and plunger.

4.2 Initial check

With a tape loaded in the cassette holder, set the Power switch to ON and check the following operations.

- (1) The display in reverse mode is " \supset ". The display is switched from " \supset ", " \supset " and back to " \supset " each time the REV. MODE selector button is pressed.
- (2) The tape running direction indicator, forward play or reverse play, depends on the tape running direction before the power was last switched off.

- (3) The operation buttons become operable 4 seconds after the power is switched on.

a) When a cassette tape is loaded in the cassette holder, the tape running direction indicator flashes, then lights 4 seconds later.

b) When a cassette tape is not loaded in the cassette holder, the tape running indicator lights 4 seconds later.

- (4) When the mechanism is not in the stop mode, turning the power switch on resumes the stop mode.

4.3 Microprocessor Operational Check

4.3.1 VDD, INT, RES power ON/OFF condition

Figure 5 shows the leading and trailing characteristics of each VDD, INT and RES pin of the feature control microprocessor (QU01), mechanism control microprocessor (QU11, QU31), and figure 4 shows its diagram. Each timing is important for the normal function the microprocessors.

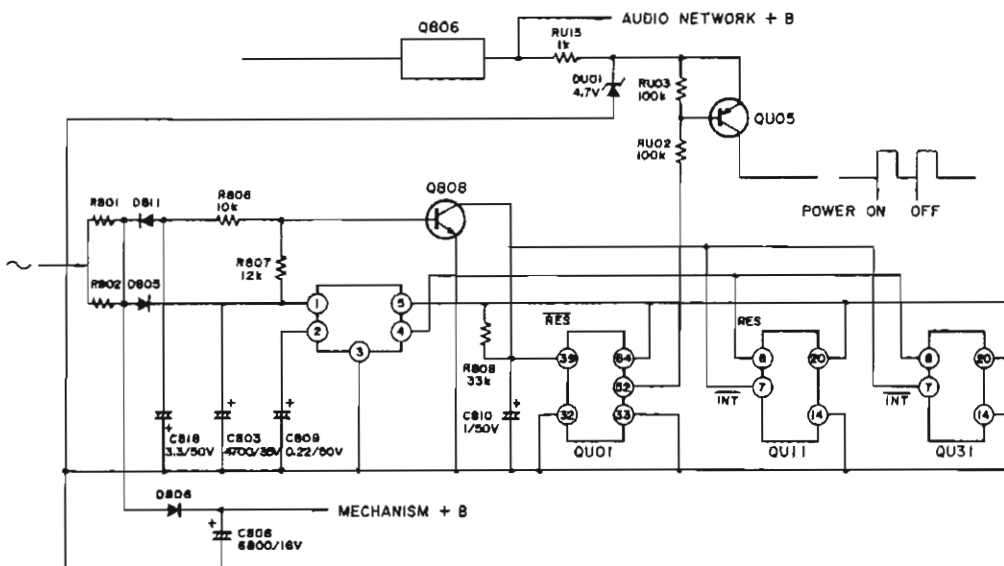

Figure 4

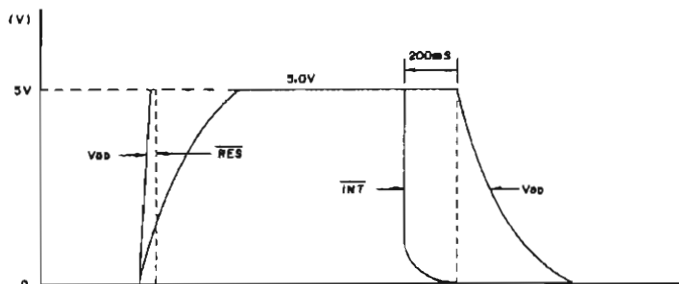

Figure 5

4.3.2 Operational description of each section

(1) Q807: Regulator with reset function

L78MR05 RESET OPERATION $C_d = 0.1 \mu F$

The microprocessor \overline{RES} input is set so the signal is applied slightly after the rising of VDD (power ON), and slightly before the trailing time (power OFF). This time lag is determined by C809 connected to IC pin ②. Figure 7 shows the timing diagram.

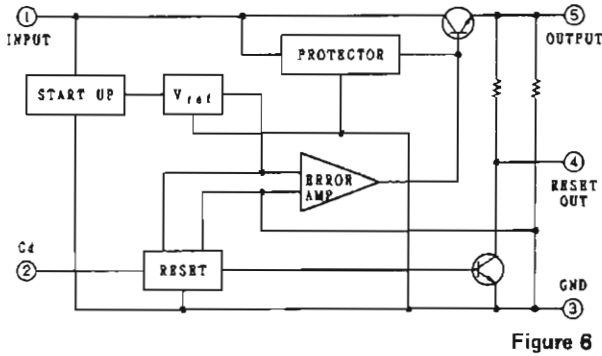

Figure 6

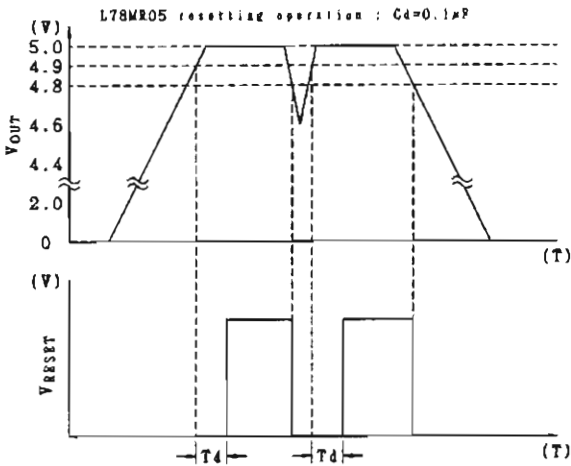

Figure 7

(2) R801, D805, C803

Used for VDD back up in the microprocessor; backs up the microprocessor for the time required to return the mechanism to the initial condition (stop mode) when the power is turned off.

(3) R802, D806, C806

Used for the power back up of the mechanism. Backs up the solenoids and capstan motor for the time required to return the mechanism to the initial condition (stop mode) when the power is turned off.

(4) C810, C818, D811, Q808, R806 ~ R808

Generates signals for the feature microprocessor \overline{RES} and mechanism microprocessor \overline{INT} . The feature microprocessor \overline{RES} goes high from low after the mechanism microprocessor has been set. The stop condition on turning the power off is set at the mechanism microprocessor \overline{INT} pin, and the stop operation is activated when it goes low from high. To obtain the fast trailing characteristic on power off, the charged energy of the ripple filter C808 is discharged via R803.

(5) RU03, RU02, QU05

Outputs the audio mute signal when the power is turned on/off. When transistor QU05 turns on, the QU01 output turns these on immediately to reduce pop noise.

4.3.3 Feature microprocessor and mechanism microprocessor

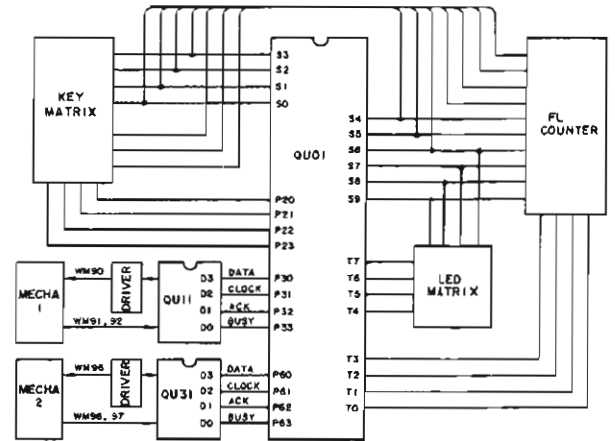

Figure 8

- Transmission/reception of feature microprocessor and mechanism microprocessor. Bidirectional transmitting/receiving is performed with 4 I/O lines.
- When the \overline{RES} pin of feature microprocessor goes high from low, RES command is output to the mechanism microprocessor via DATA line.
- Mechanism microprocessor has the function to the control mechanism and to judge the interval between tunes when searching.

4.3.4 Key matrix

	④ S0	③ S1	② S2	① S3	⑥ S4	⑤ S5	⑥ S6
⑫ P20	—	—	—	—	Counter Res	Blank Skip	—
⑭ P21	—	Memory	Hi-speed Dubbing	Normal Dubbing	—	Pause	Stop
⑮ P22	—	QMS	Deck B	Continuous Play	Rec Mute	F.F	Rew
⑯ P23	—	Reverse Mode	Deck A	—	Rec	Fad Play	Rev Play

4.3.5 Initialization

Turn the power switch on.

- (1) When the $\overline{\text{RES}}$ signal from QU01, QU11, QU31 rises the capstan motor rotates to return the head chassis to the stop position, if it is not in the stop mode.
- (2) When the head chassis is already in the stop position, or 4 seconds after the head chassis has been returned to the stop position, the tape running direction indicator lights.
- (3) When the tape running direction indicator lights, the microprocessors begin accepting the timer-play, timer-rec and each operation key.

Check points on abnormal initialization

★ When operation (1) does not function (when head chassis is not in the stop position):

- a) Check the waveform of QU11 pin ⑥.



- b) Check the rising characteristics of VDD, $\overline{\text{INT}}$ and $\overline{\text{RES}}$. When they go high with the rising characteristics shown in Fig. 5, they are normal.
- c) When the head is not returned to the stop position, check the motor drive circuit and its vicinity.

★ When operation (2) does not function:

- a) When the tape running direction indicator is not lit, check the display PC board and surrounding wiring, etc. When the indicator does not blink after four seconds with the tape loaded, check that QU11, QU31 pin ⑥ is low with the tape loaded. (When the power is turned on, the initial condition of the mechanism is transmitted to the feature microprocessor.)
- b) When the forward direction indicator (▷) lights in spite of the head being in the reverse direction, check the wiring of FWD/REV switch, etc. QU11, QU31 pin ⑥ is low when in reverse mode.

★ When operation (3) does not function:

- a) Key operation does not function:
When more than two keys are pressed causing switch binding on the mechanism control key switch PC board, the key operations are not accepted.
- b) When the cassette-in switch of the mechanism is not set ON, check the switch condition and wiring, etc.

5. MOTOR DRIVE CIRCUIT

5.1 F/R Motor Drive Circuit

The direction of F/R motor rotation is determined by the output from pins ⑬ ⑭ of QU11/31, and the winding torques in PLAY and FF/REW modes are switched by pin ⑮ of QU11/31.

The Output according to the pin operating condition is shown below.

QU11/31 PIN NO.	STOP	FF	REW	FORWARD PLAY	REVERSE PLAY
⑮	L	H	L	H	L
⑬	L	L	H	L	H
⑭	H	H	H	L	L

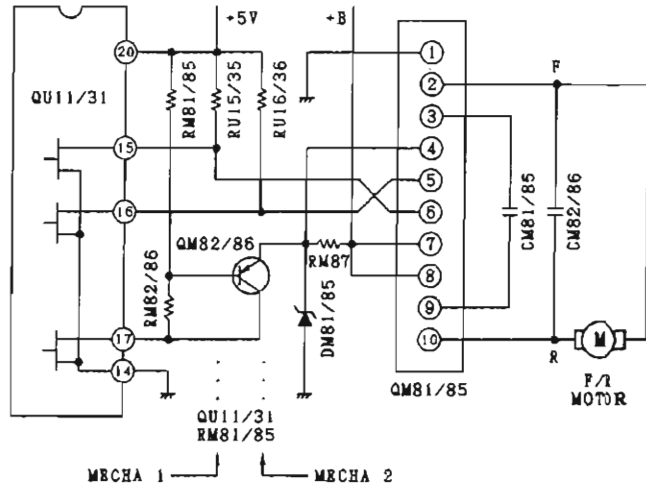

Figure 9

5.2 Capstan Motor Drive Circuit

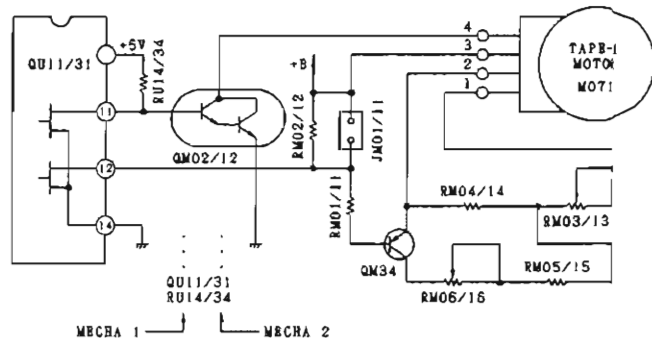

Figure 10

Other than the normal tape running condition, the capstan motor also rotates when the head chassis is shifted up and down. Therefore, when a malfunction occurs in the capstan motor drive circuit, the head chassis cannot be moved.

High-Speed Mode:

To rotate the capstan motor in high speed mode, set QM34 to OFF. By short-circuiting JM01/11, the capstan motor is changed to the high-speed mode during Play. When performing speed adjustment, first adjust in the high speed mode, then perform normal speed adjustment.

5.3 Solenoid Drive Circuit

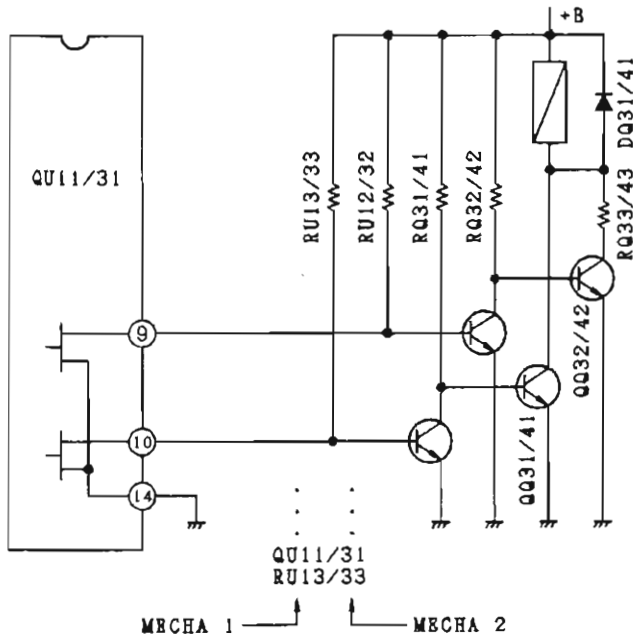

Figure 11

To shift the head chassis up/down, solenoids are energized for a fixed time so that the cam gear and the flywheel gear can engage.

Depending on the shape of the gear and its purpose, the energizing time differs.

RQ33/34 prevent heating of solenoid when it is pulled continuously such as Cue/Rev mode.

QU11/31 PIN NO.	STOP → FWD PLAY	STOP → REV PLAY	FWD/REV PLAY → STOP	CUE/REV
⑨				—
⑩				—

6. OTHER INPUTS AND OUTPUTS

6.1 QMS

Press the QMS button repeatedly by the number of tuned to be skipped during STOP or PLAY mode, and then press FF or REW button (◀/▶) in the direction of the desired tune to be selected to activate the tune select function. At this time, the FL counter shows the number (1 to 15) pressed.

The QMS circuit converts the playback signal through the comparator so that the microprocessor can be read. The level setting is performed by the QMS circuit, and judgement of the interval time between tunes is set internally in the microprocessor.

6.1.1 Playback speed and time constant

If the FF/REW time is set to 100 sec, the FF/REW speed at the beginning of the tape is 11 times normal PLAY speed, and becomes approx. 25 times at the end of the tape. The interval between tunes is usually set to 4 seconds in PLAY speed. Therefore, the interval time between tunes in the CUE/REVIEW mode becomes 160–370 msec.

6.1.2 Microprocessor setting

The mechanism microprocessor provided with this unit uses the time-read system for detecting the interval between tunes. For this, it takes 3 seconds in PLAY mode and 120 msec in CUE/REVIEW mode to read out the intervals.

6.1.3 Judgement level setting

(0dB, 200nWB: The characteristic that Q01 output goes high from low according to the recording level on the tape)

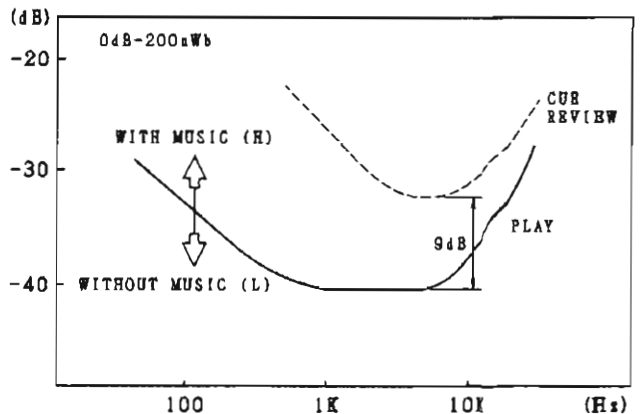

Figure 12

a) Frequency response is changed between PLAY mode and search mode, to prevent malfunction with the music signal. In PLAY mode, Q02 is turned ON and the frequency response is widened.

Switching between PLAY mode and search mode is performed by pin ⑨ of QU01; it goes low in PLAY mode.

6.2 REEL PULSE Terminal

Pin ⑩ of QU11/31 is connected to the output of the reel rotation sensor. Using this output, Auto Shut-off, Memory Rewind Stop and cueing compensation in QMS mode are performed.

The Auto Shut-off function is operated 5.2 seconds after the reel rotation output pulse is stopped.

7. SINGLE-CHIP 4-BIT MICROCOMPUTER FOR LM6413E (QU11/QU31) N-CHANNEL E/D MOS LSI

● SYSTEM BLOCK DIAGRAM

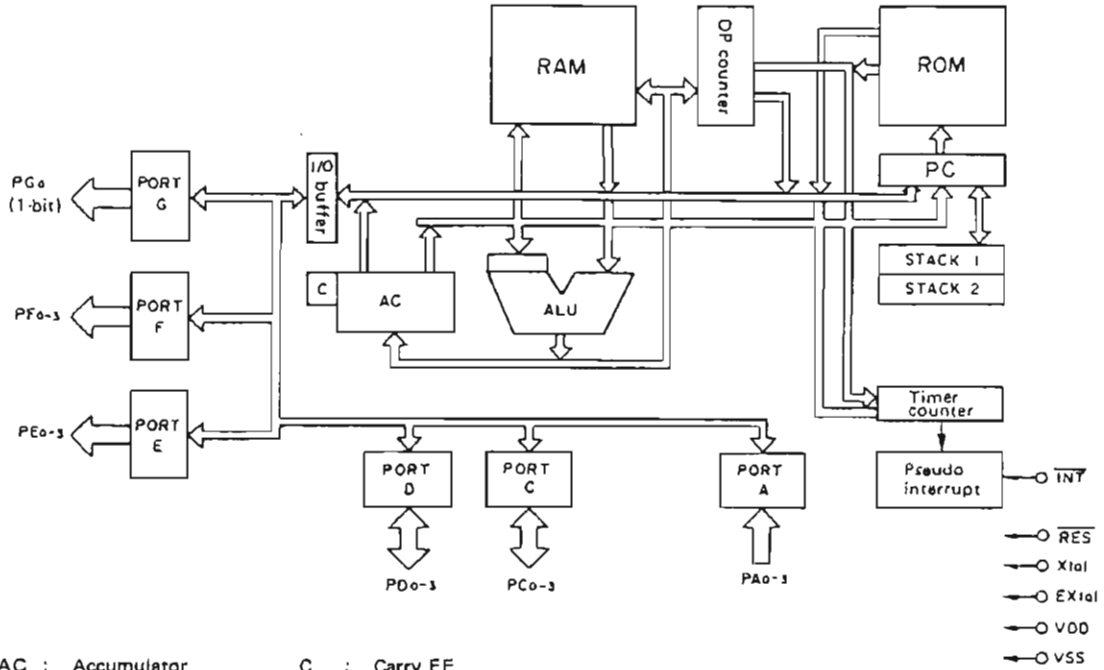
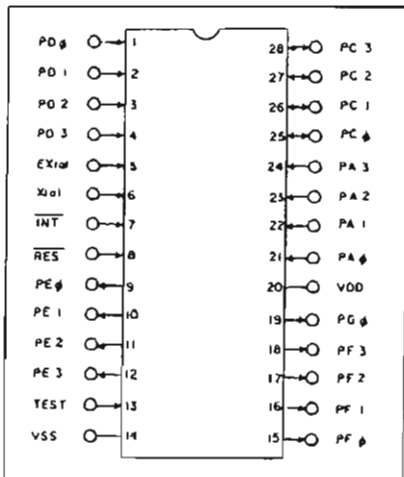

Figure 13

● PACKAGE AND TERMINAL NAME



(Terminal Name)

Xtal, EXtal : Resonator for oscillator
 INT : Interrupt
 RES : Reset
 PA₀₋₃ : Input port A₀₋₃
 PC₀₋₃ : I/O port C₀₋₃
 PD₀₋₃ : I/O port D₀₋₃
 PE₀₋₃ : Output port E₀₋₃
 PF₀₋₃ : Output port F₀₋₃
 PG₀ : Output port G₀
 TEST : Test

● TERMINAL FUNCTION (LM6413E QU11/QU31)

Terminal Name	I/O	Function
$\overline{\text{INT}}$	Input	Pseudo interrupt request input terminal.
$\overline{\text{RES}}$	Input	Reset input terminal.
PA_{3-0}	Input	Input ports A_3 to A_0 . In input mode, 4-bit input and bit test are allowed.
PC_{3-0}	I/O	I/O ports C_3 to C_0 . In input mode, 4-bit input and bit test are allowed. In output mode, 4-bit output, bit set/reset and immediate data output are allowed.
PD_{3-0}	I/O	I/O ports D_3 to D_0 . In input mode, 4-bit input and bit test are allowed. In output mode, 4-bit output, bit set/reset and immediate data output are allowed.
PE_{3-0}	Output	Output ports E_3 to E_0 . 4-bit output and bit set/reset are allowed.
PF_{3-0}	Output	Output ports F_3 to F_0 . 4-bit output and bit set/reset are allowed.
PG_0	Output	Output port G_0 . In output mode, 1-bit output and bit set/reset are allowed.
X'tal	I/O	External terminal of the resonance circuit for local clock signal oscillation. A ceramic resonator and CR are connected to the space between this terminal and Ex'tal terminal.
Ex'tal	Input	Terminal operated with clock signal externally supplied. A ceramic resonator and CR are connected to the space between the X'tal and this terminals when using the local clock signal oscillator.
VDD	Input	Power terminal, usually connected to +5V.
VSS		Connected to 0V of power supply.
TEST	Input	LSI test terminal, usually connected to V_{SS} (0V).

μ PD75206CW (QU01) W-MECHA FEATURE & COUNTURE DRIVER

BLOCK DIAGRAM

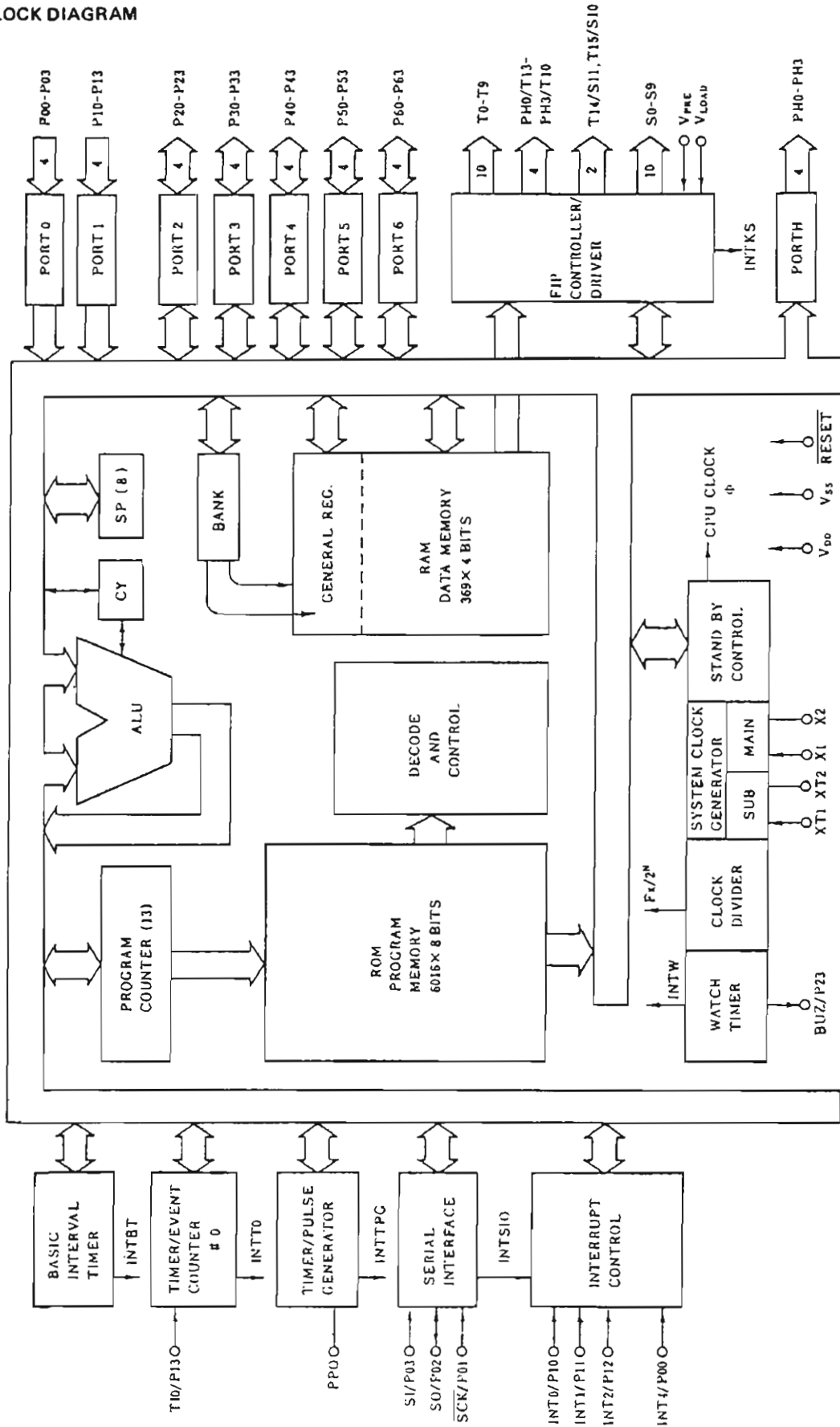
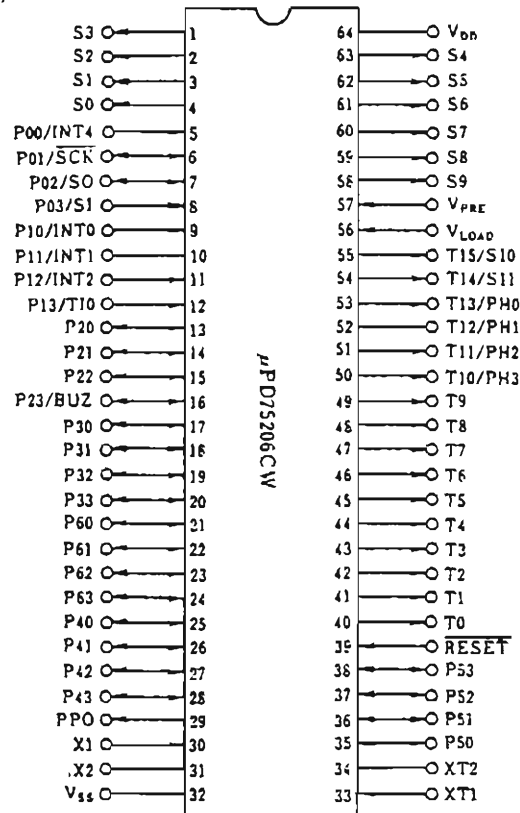

Figure 14

Terminal Connection (Top View)



1. Terminal Function

1.1.

Pin	Input/Output	Combined Terminal	Function	When Reset
P00	Input	INT4	4-bit input port (PORT0)	Input
P01	Input/Output	SCK		
P02	Input/Output	SO		
P03	Input	SI		
P10	Input	INT0	4-bit input port (PORT1)	Input
P11		INT1		
P12		INT2		
P13		T10		
P20	Input/Output	—	4-bit I/O port (PORT2)	Input
P21		—		
P22		—		
P23		BUZ		
P30–P33	Input/Output	—	Programmable 4-bit I/O port (PORT3). I/O setting is possible in 1-bit units.	Input
P40–P43	Input/Output	—	4-bit I/O port (PORT4). Permits direct LED control.	Input
P50–P53	Input/Output	—	4-bit I/O port (PORT5). Permits direct LED control.	Input
P60–P63	Input/Output	—	Programmable 4-bit I/O port (PORT6). I/O setting is possible in 1-bit units. Built-in pulldown resistor. Optimum for key input.	Input
PH0	Output	T11	4-bit P-ch open-drain, high voltage resistance, large current output port (PORTH). Permits direct LED control. Pulldown resistor attachable (mask option).	Low level (with pulldown resistor attached) or high impedance.
PH1		T12		
PH2		T13		
PH3		T14		

1.2.

Pin	Input/Output	Combined Terminal	Function		When Reset
T0–T9	Output	—	FIP controller/ driver output port (1-bit units). Pulldown resistor attachable (mask option).	High voltage resistance, large current digit output port.	Low level (with pulldown resistor attached) or high impedance (w/o pulldown resistor).
T10–T13		PH3–PH0		High voltage resistance, large current digit output port. Surplus pins can be used as PORTH.	
T14/S11, T15/S10		—		High voltage resistance, large current digit/segment output port. Can also be used for static output.	
S9		—		High voltage resistance segment output port. Can also be used for static output.	
S0–S8		—		High voltage resistance segment output port.	
P0	Output	—	Timer/pulse generator pulse output port.	High impedance	
T10	Input	P13	External event pulse input port for the timer/event counter.		
SCK	Input/Output	P01	Serial clock input port.	Input	
SO	Input/Output	P02	Serial data output or input/output port.	Input	
SI	Input	P03	Serial data input or normal input port.	Input	
INT4	Input	P00	Edge detection vector insertion input port (both rising and falling edges are detected).		
INT0	Input	P10	Edge detection vector insertion input port (with noise reduction) (the detected edge can be selected).		
INT1		P11			
INT2	Input	P12	Edge detection testable input port (rising edge is detected).		
BUZ	Input/Output	P23	Fixed frequency output port (for buzzer or system clock trimming).	Input	
X1, X2		—	Main system clock oscillator crystal/ceramic connection port. When using an external clock, input to X1, and its opposite phase to X2.		
XT1, XT2		—	Sub system clock oscillator crystal connection port. When using an external clock, input to XT1, and open XT2.		
RESET	Input	—	System reset input port (low level active).		
VPRE		—	FIP controller/driver output buffer power supply port.		
VLOAD		—	FIP controller/driver pulldown resistance connection port.		
VDD		—	Positive power terminal.		
VSS		—	Ground terminal.		

8. MECHANISM OPERATIONAL DESCRIPTION

8.1 STOP

The head position is always pointed in the FWD direction. (Refer to Fig. 15.)

8.2 FWD (FORWARD) PLAY

a) When voltage is applied to the solenoid, the play arm is released by the stopper of the cam, and the cam gear is engaged with the flywheel gear and rotation starts.

By the rotation of the cam gear, the head chassis is driven as shown in Fig. 18.

b) When the cam of Item a operates, it is guided towards the cam section for FWD operation and locked in the condition shown in Fig. 19.

8.3 REVERSE PLAY

a) When voltage is applied to the solenoid, it is held for a duration longer than the FWD PLAY.

While the solenoid is held for a longer period, it is guided to the can slot for REVERSE operation and locked in the condition shown in Fig. 20.

b) The head chassis is driven in the same way as Item. 6.2 a above.

8.4 FWD/REV PLAY → STOP

Voltage is applied to the solenoid to rotate the cam gear, and the mechanism returns to the condition shown in Fig. 6.

(The head position always points in the FWD direction.)

8.5 CUE/REVIEW (PLAY → CUE/REVIEW)

To start CUE/REVIEW (QMS) from FWD/REVERSE PLAY, voltage begins to be applied during PLAY and the condition is as shown in Fig. 17.

8.6 CUE/REVIEW → PLAY

When voltage is applied to the solenoid in, the condition of Item 6.5, the cam is returned to STOP mode condition and STOP then PLAY is operated.

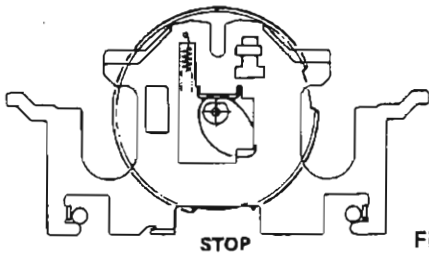

Figure 15

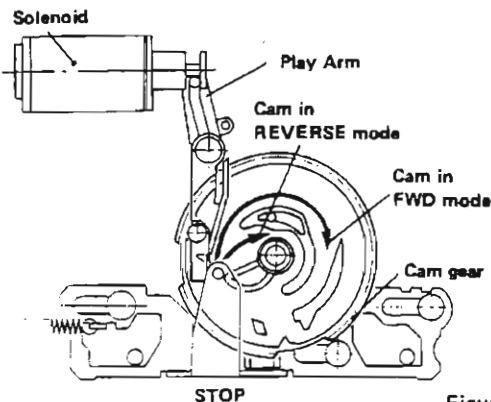

Figure 16

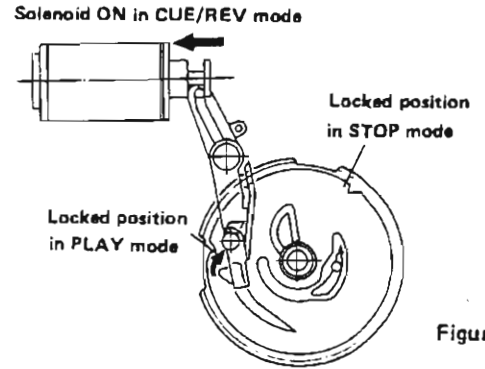

Figure 17

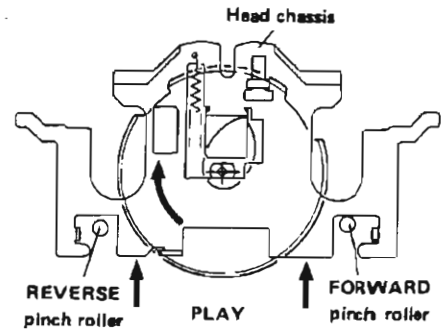

Figure 18

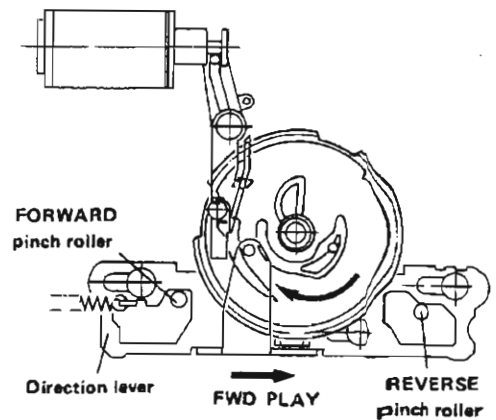

Figure 19

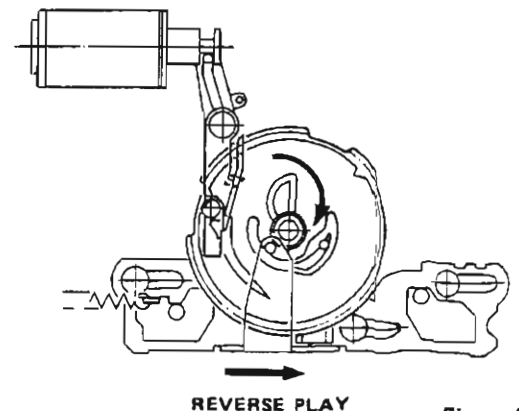
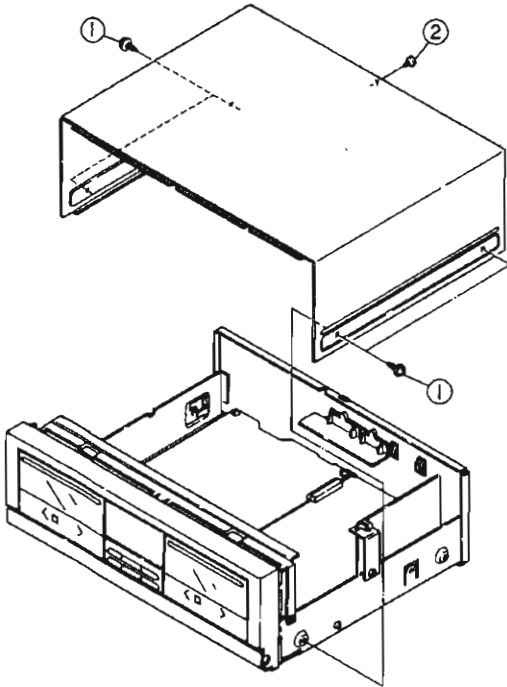

Figure 20

9. DISASSEMBLY

9.1 REMOVING THE TOP COVER

Remove the fixing screws ① 4 and ② 1 shown in the figure.



9.3 REMOVING THE MECHANISM

After removing the cassette covers ④ as shown in the figure, remove the ⑤ 1 and ⑥ 8 fixing screws.

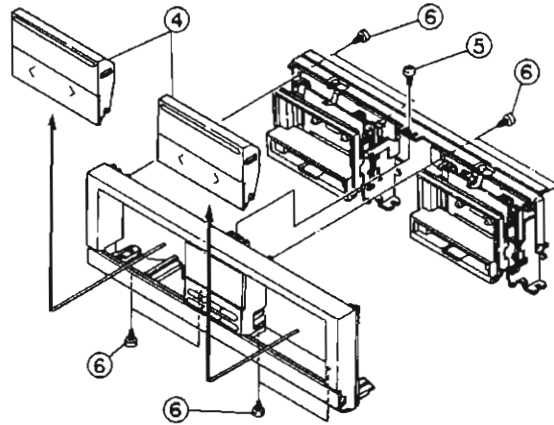

9.2 REMOVING THE FRONT PANEL

After removing the top cover, remove the 7 fixing screws ③ shown in the figure.

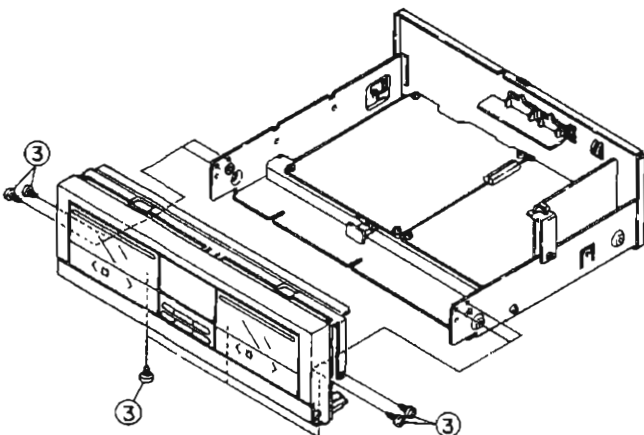

9.4 REMOVING THE MAIN P.W. BOARD

After removing the bracket ⑧ and the fixing screw ⑦ as shown in the figure, remove the 6 board fixing screws ⑨.

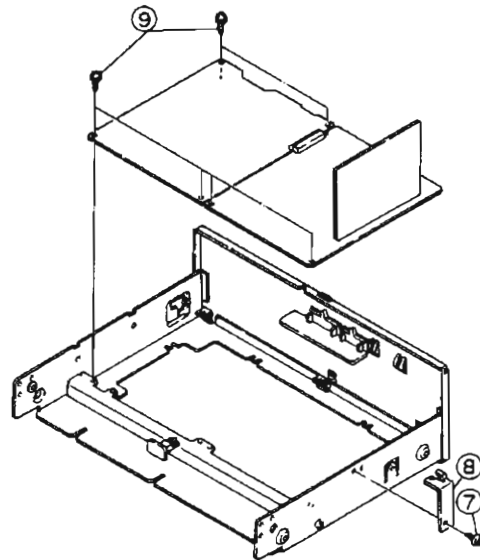

10. ELECTRICAL ADJUSTMENTS

Precautions before Adjustment

1. Before playing the test tape back, thoroughly demagnetize the heads, capstan and similar metal parts using an eraser as the test tape-recorded tone is easily erased.
2. Do not place the test tape on any measuring instrument.
3. Do not put the test tape near a place where the eraser is used.
4. Method of Demagnetization: — Turn the eraser power switch on at a remote position far away from the heads. Bring the eraser close to the heads, capstan and other parts to be demagnetized, and move it up and down four or five times to demagnetize. Slowly separate the eraser far away from the parts, and turn the power switch off.
5. Do not use any magnetize it from time to time in the course of each adjustment.
6. Do not turn semi-fixed resistor more than needed.
7. Do not apply locking bone excessively.

ADJUSTMENT POINT (COMPONENT SIDE)

PU03

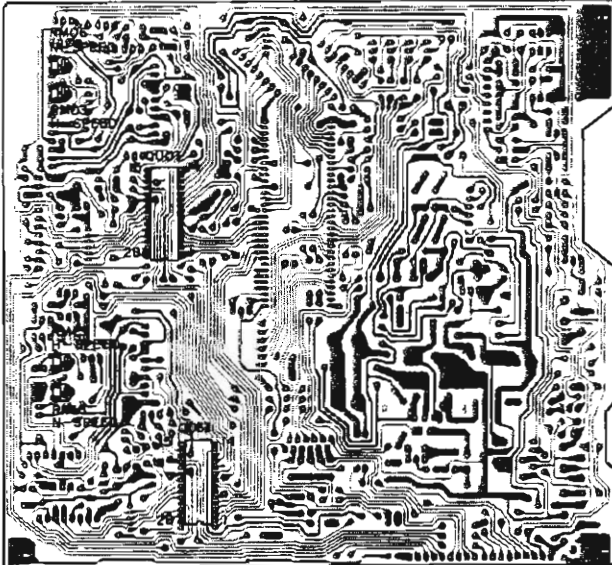

PJ03

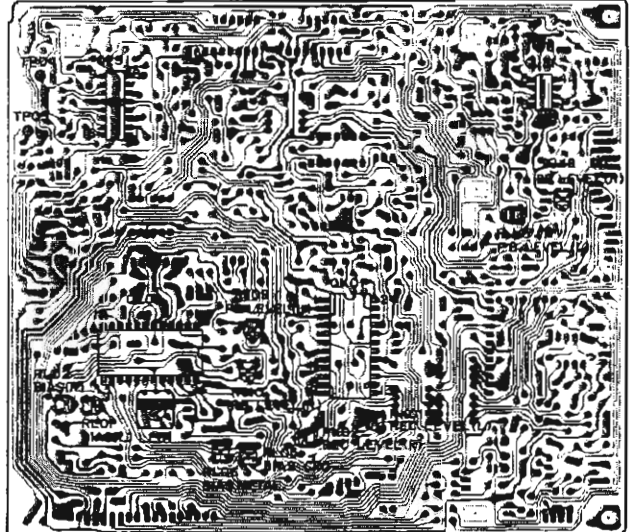

P603

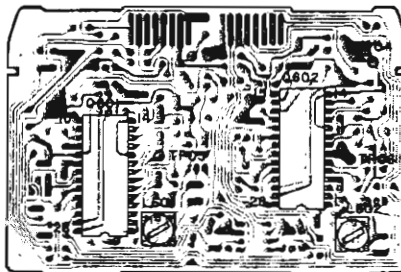

10.1 TAPE SPEED ADJUSTMENT

(TAPE 1)

1. Play back the middle section of the test tape TCW-211, and adjust the tape speed adjusting semi-fixed resistor (RM03) for 3000 to 3010 Hz frequency counter indication. (High speed mode: 9.5 cm/sec)
Before above adjustment, short-circuit JM01.
2. Play back the middle section of the test tape TCC-111, and adjust the tape speed adjusting semi-fixed resistor (RM06) for 2990 to 3010 Hz counter indication. (Normal speed mode: 4.8 cm/sec)
3. To check that the adjustment is correctly performed, rewind the tape and play back again to confirm the counter values are within the allowable range.

(TAPE 2)

1. Play back the middle section of the test tape TCW-211, and adjust the tape speed adjusting semi-fixed resistor (RM13) for 2980 to 2990 Hz counter indication. (High speed mode: 9.5 cm/sec)
At this time, short-circuit JM11 before adjustment.
2. Play back the middle section of the test tape TCC-111, and adjust the tape speed adjusting semi-fixed resistor (RM16) for 2990 to 3010 counter indication. (Normal speed mode: 4.8 cm/sec)
3. To check that the adjustment is performed correctly, rewind the test tape and play back again to confirm the counter reading value is within the allowable range.

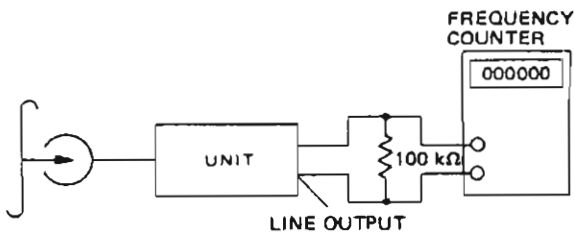

NOTES:

1. Do not adjust after the unit is subjected to an excessive temperature change.
2. Be careful that the frequency counter may indicate an incorrect value because of too low of a counter input level.
3. Perform the above adjustments, after approx. 10 to 20 seconds.
4. When adjusting, be sure to perform the high-speed adjustment. To set the unit to high speed mode, short-circuit the pin of JY01? (JM01 for TAPE 1, JM11 for TAPE 2) from the normal playback mode.

10.2 HEAD AZIMUTH ADJUSTMENT

1. Play back the 14 kHz signal of the test tape MTT-256, and rotate the head azimuth adjusting screw for a maximum VTVM reading.
2. If the peak level reads of the right and left channels are different, set the lower channel to maximum.
3. After adjustment, be sure to lock the screws with bond.

NOTE:

Be sure to adjust with the same section on the same side of the tape of both TAPE 1 and TAPE 2.

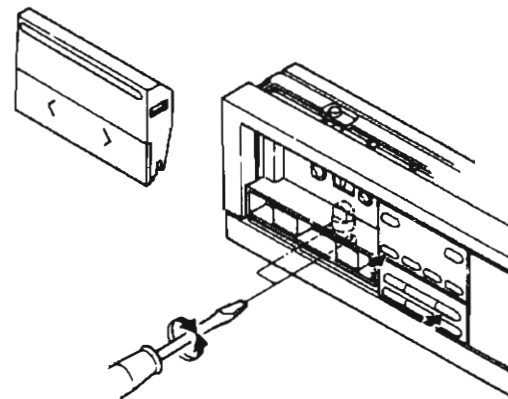
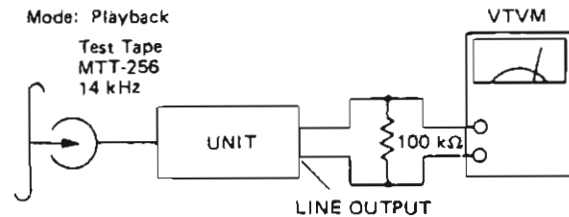

10.3 PLAYBACK OUTPUT LEVEL ADJUSTMENT

1. Play back the test tape MTT-150, and adjust RJ47(L)/RJ48(R) for TAPE 1, RJ09(L)/RJ10(R) for TAPE 2, so that the pin voltage at the Dolby test point (TP5, 6) becomes 387.5 mV.
2. Rewind the tape and play back again to confirm that both levels are the same.

10.4 RECORDING/PLAYBACK LEVEL ADJUSTMENT

1. Load a normal tape.
2. Set the ALC circuit to its maximum sensitive condition. (Short-circuit between test points TP04 and TP05 with short-circuiting pin.)
3. Apply the 1 kHz, 230 mV signal to the Line Input terminal and record it. Then play it back and adjust RK01 (L) and RK02 (R) so that it becomes the same level as the monitor level. For CrO₂ and Metal tape, adjust following the same procedure and confirm that the level difference between the recording (input) level and the playback (monitor) level is within 1 dB.

10.5 REC/PLAY FREQUENCY RESPONSE ADJUSTMENT AND MEASUREMENT

(NORMAL)

1. Load the AC-212 test tape and set the deck to the recording mode (input: 230 mV). Then reduce the level by 22 dB with the attenuator and record 1 kHz and 10 kHz on the non-recorded section. (DOLBY C position)
2. Rewind the tape and play it again, and adjust RL01 (L) and RLO2 (R) so that the playback level differences of 1 kHz and 10 kHz is within 0 to ± 1.0 dB.
3. After adjustment, record 1 kHz, 10 kHz and 12.5 kHz signals, and check that the playback level differences of these frequencies are as gives below.
4. Set the DOLBY switch to OFF, record 1 kHz and 12.5 kHz signals, and check that the playback level differences are as given below.
5. With the DOLBY switch OFF, check that the L/R channel balance for 10 kHz is less than 3 dB.

NOTE:

When 1 kHz level difference in DOLBY C mode is 1 dB or more compared to the monitor level, adjust RK01 (L) and RK02 (R) for the recording level adjustment previously, so that the level difference is within 1 dB.

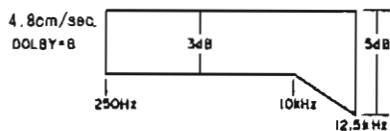
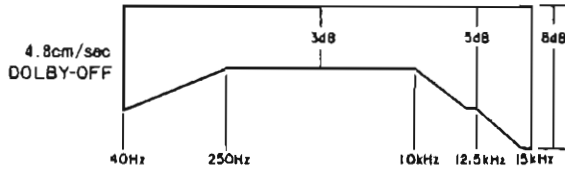

(CrO₂)

1. Load the AC-512 test tape and set the deck to the recording mode (input: 230 mV). Then reduce the level by 22 dB with the attenuator, and record 1 kHz and 10 kHz signals on the non-recorded section. (Dolby C position)
2. Rewind the tape and play it again, and adjust the Bias semi-fixed resistor RL05 so that the playback level differences of 1 kHz and 10 kHz is within 0 to ± 1 dB.
3. After adjustment, record 1 kHz, 10 kHz and 12.5 kHz signals, and check that the playback level differences are as given below.
4. Set the Dolby switch to OFF, and record 1 kHz and 12.5 kHz signals, and check that the playback level differences are as given below.
5. With the Dolby switch OFF, check that the L/R channel balance for 10 kHz is less than 3 dB.

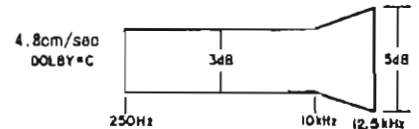
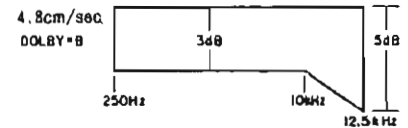
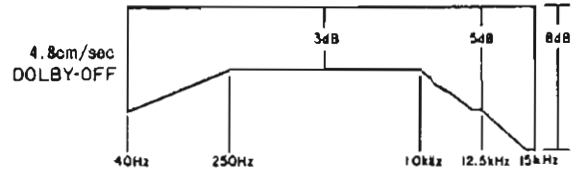

(METAL)

1. Load the AC-712 test tape and set the deck to the recording mode (input: 230 mV). Then reduce the level by 22 dB, and record 1 kHz and 10 kHz on the non-recorded section. (DOLBY C position)
2. Rewind the tape and play it, and adjust the BIAS semi-fixed resistor RL06 so that the 1 kHz and 10 kHz level difference is within 0 to ± 1 dB.
3. After adjustment, record 1 kHz, 10 kHz and 12.5 kHz signals, and check the playback level differences are as given below.
4. Set the Dolby switch to OFF, and record 1 kHz and 10 kHz signals, and check that the playback level differences are as given below.
5. With the Dolby switch OFF, check that the L/R channel balance for 10 kHz is less than 3 dB.

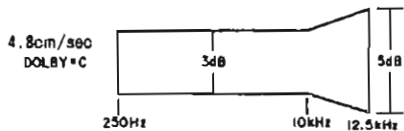
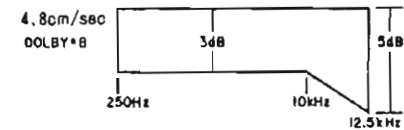
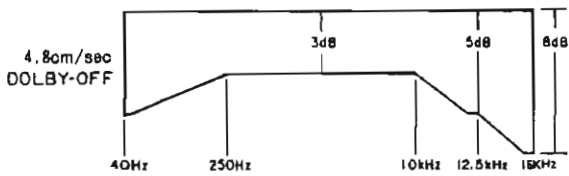

10.6 DUBBING REC/PLAY LEVEL MEASUREMENT

1. Load the MTT-150 test tape into TAPE 1 and AC-212 test tape into TAPE 2.
2. Set the deck to the dubbing recording mode of TAPE 1 to TAPE 2.
3. Rewind the AC-212 loaded into TAPE 2 and play back. Then measure it at DOLBY test points TP5 and TP6 to check that the playback output level becomes 387.5 mV ± 1 dB.

10.7 DUBBING REC/PLAY FREQUENCY RESPONSE MEASUREMENT

1. Load the MTT-256 test tape into TAPE 1 and AC-212 into TAPE 2.
2. Set the deck to the TAPE 1 to TAPE 2 dubbing recording mode.
3. Rewind the AC-212 loaded into TAPE 2 and play it back, and check that the level differences of 1 kHz and 12.5 kHz is as shown in the figure below.

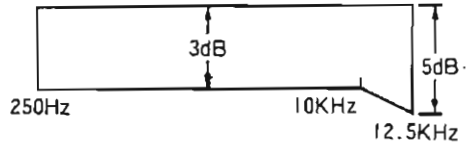

11. LEVEL DIAGRAMS

11.1 REC. LEVEL DIAGRAM

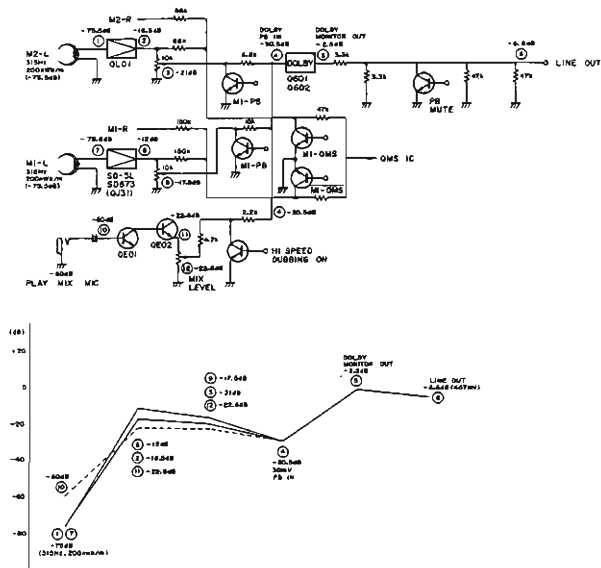

11.2 PLAYBACK LEVEL DIAGRAM

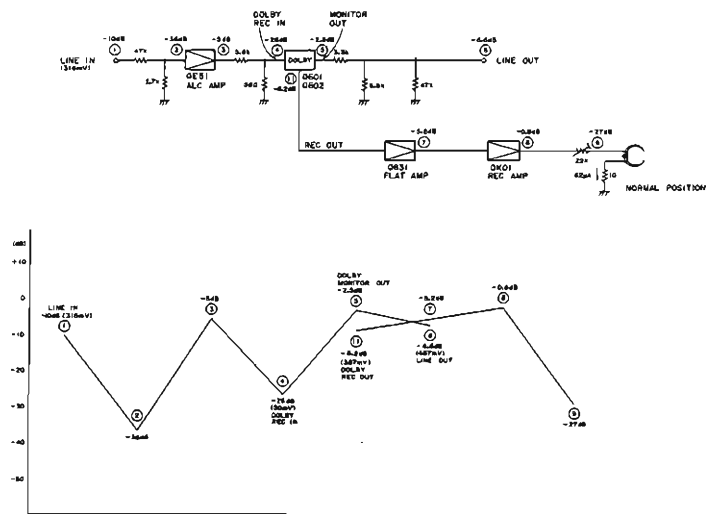

12. WIRING DIAGRAM

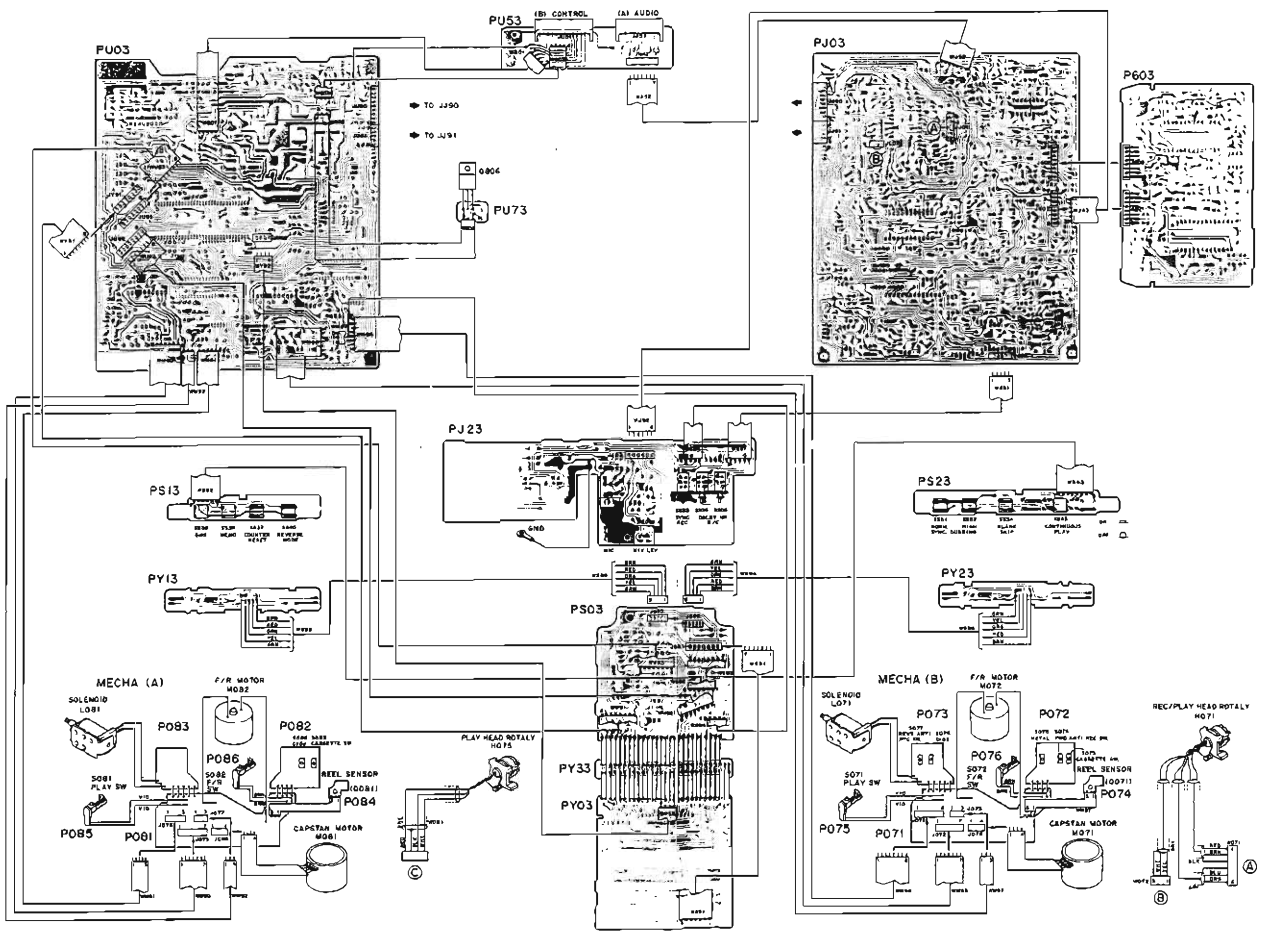

13. SCHEMATIC DIAGRAM

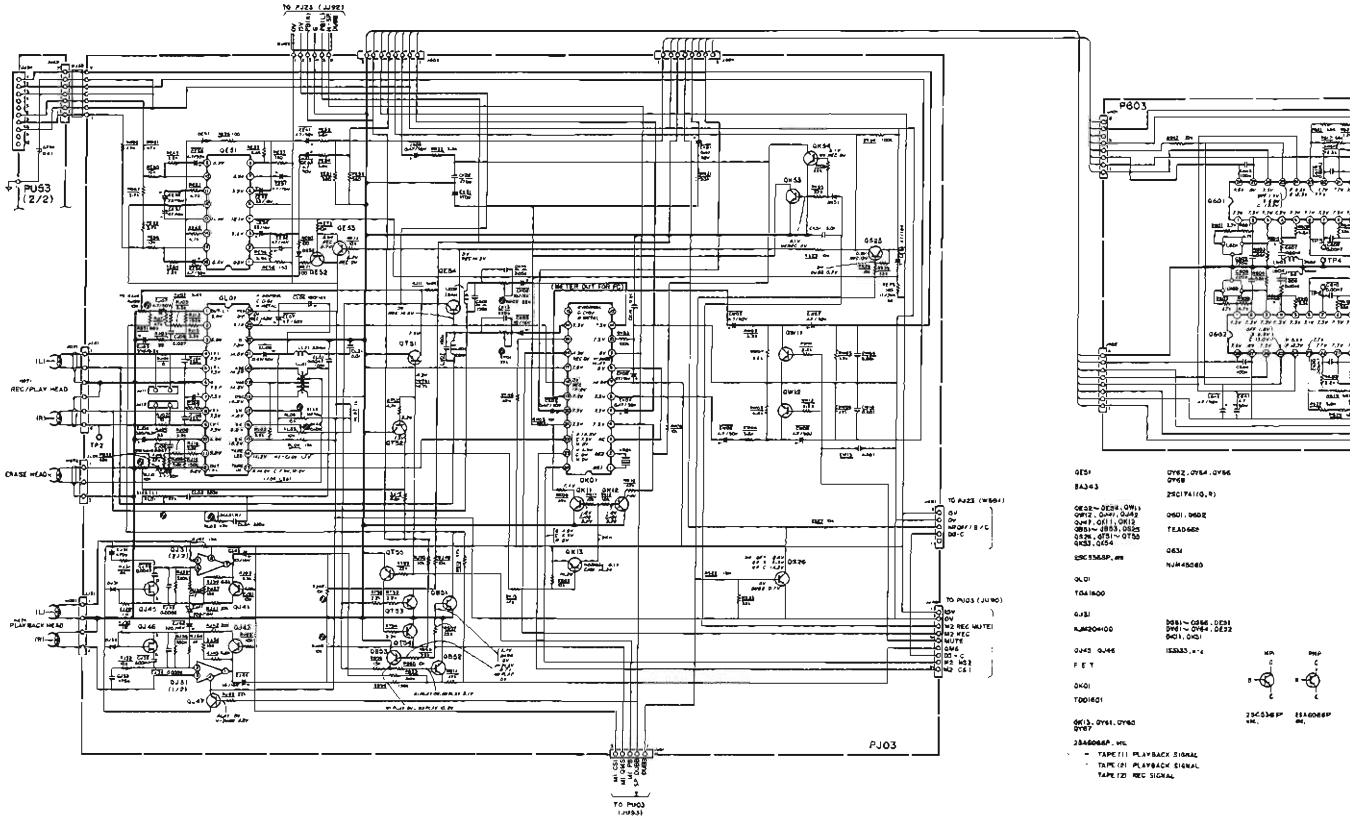

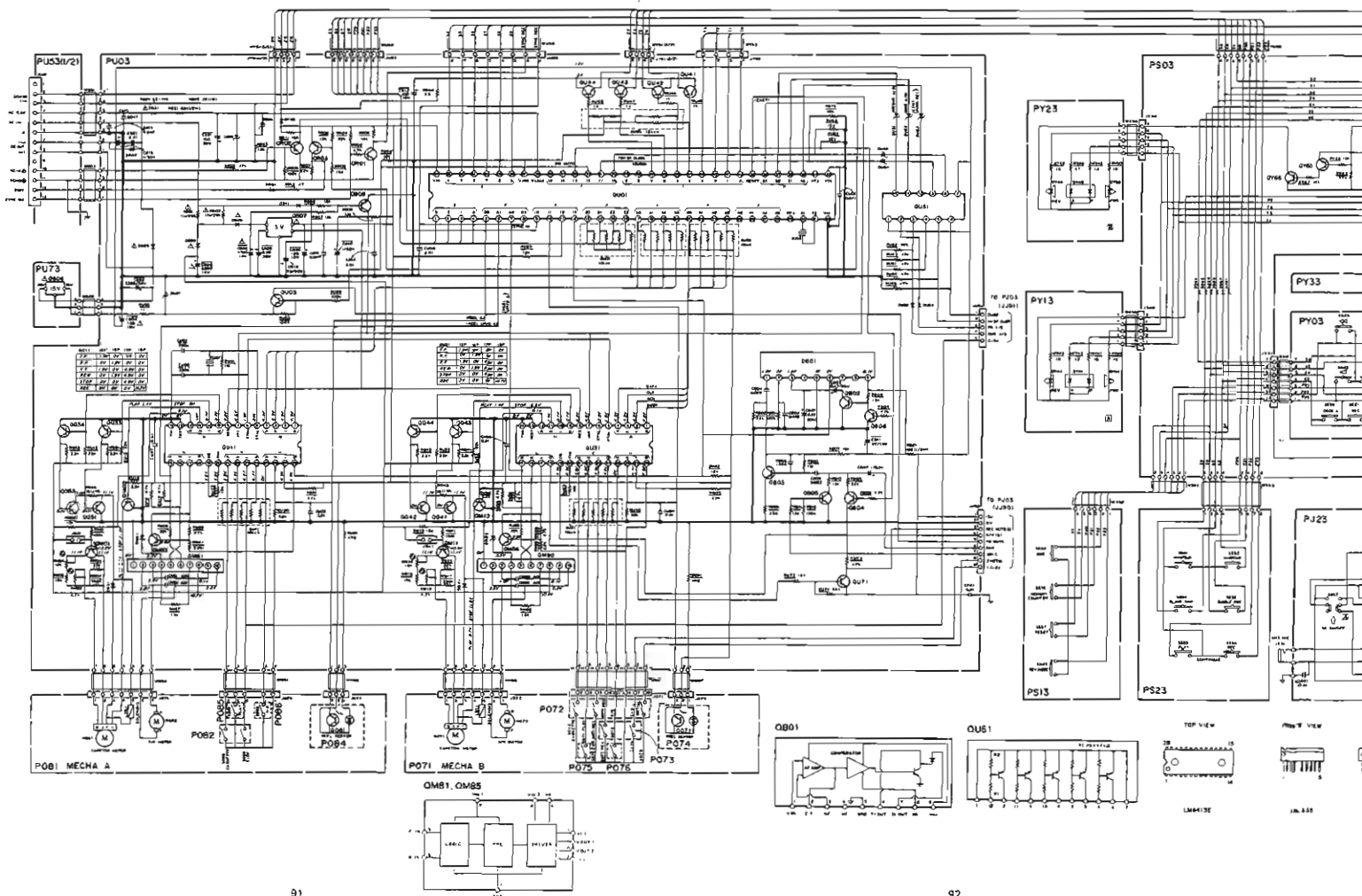

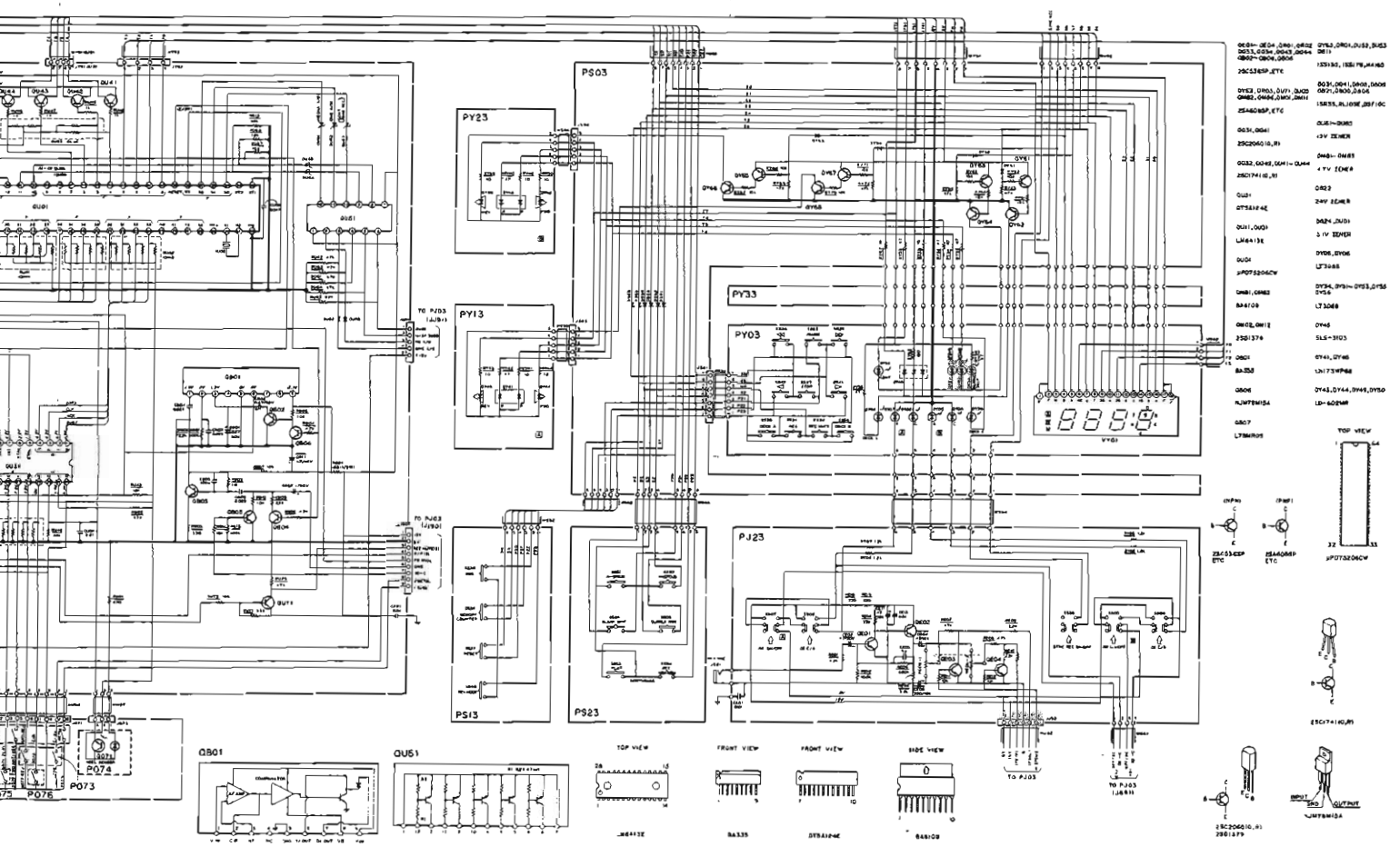

14. PARTS LOCATIONS (Patern Side)

PS03 - Wire Connect P.W. Board

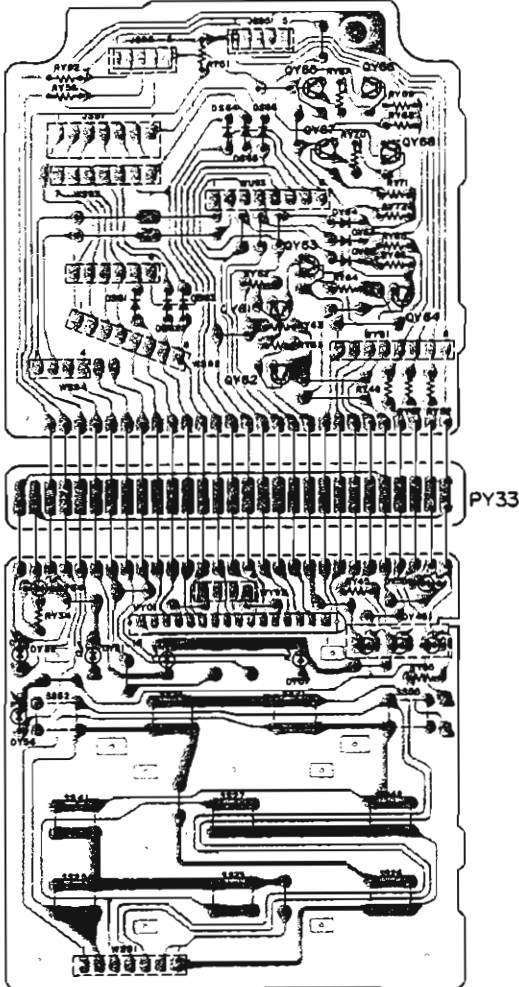

PS13 - Key Switch QMS/Memory



PS23 - Key Switch Dubb/Continuous



PY13 - Cassette LED M1



PY23 - Cassette LED M2



PY03 - Key Switch LED Indicator P.W. Board

PJ23 - NR Switch/Mix Mic Amp P.W. Board

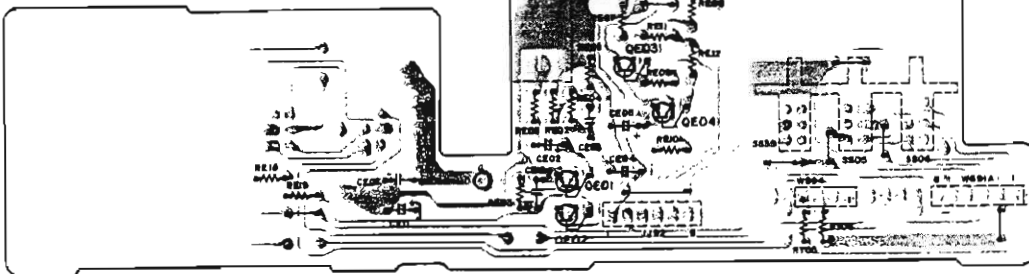

PU03 - Logic P.W. Board

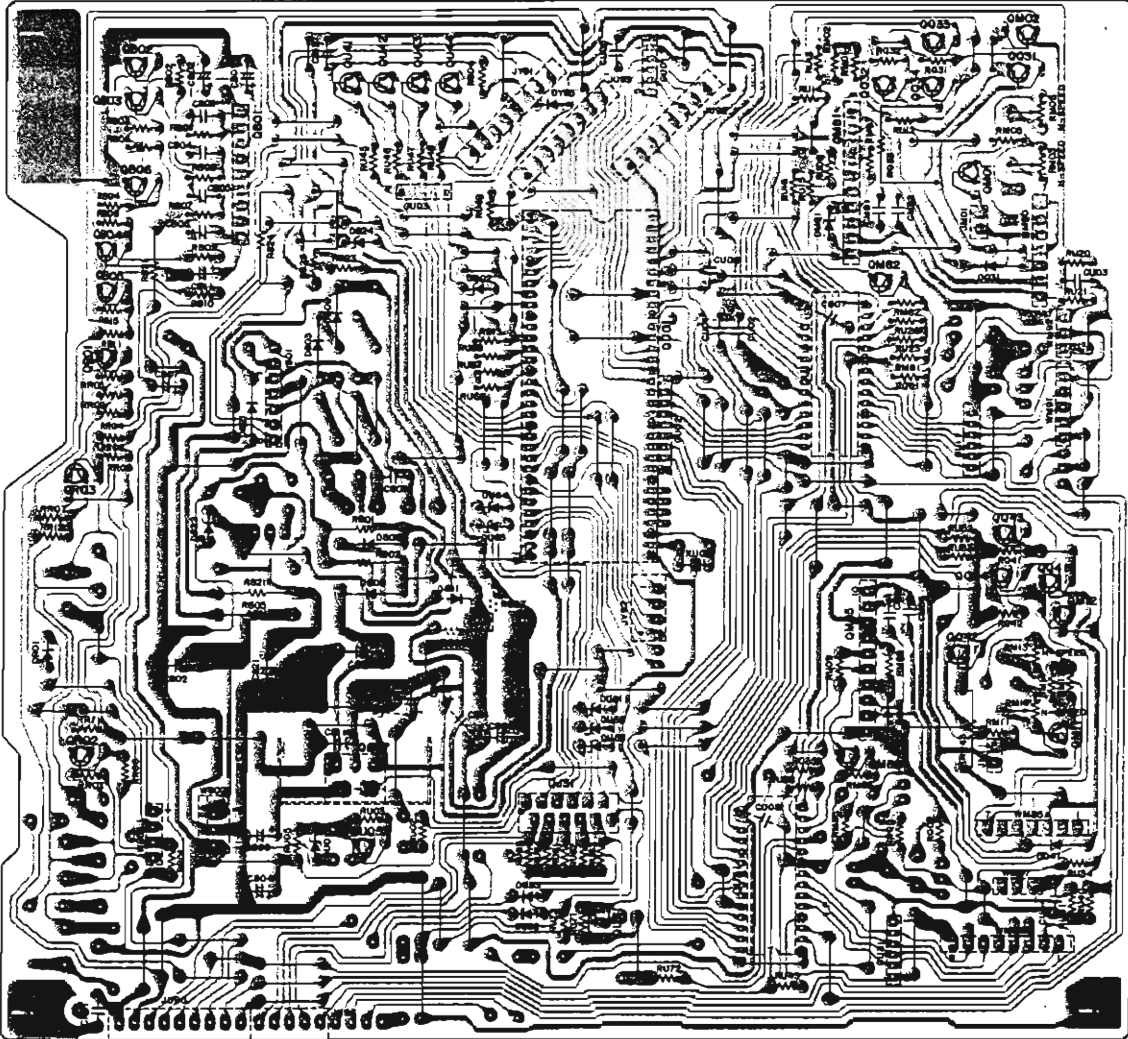

P603 - Dolby B/C P.W. Board

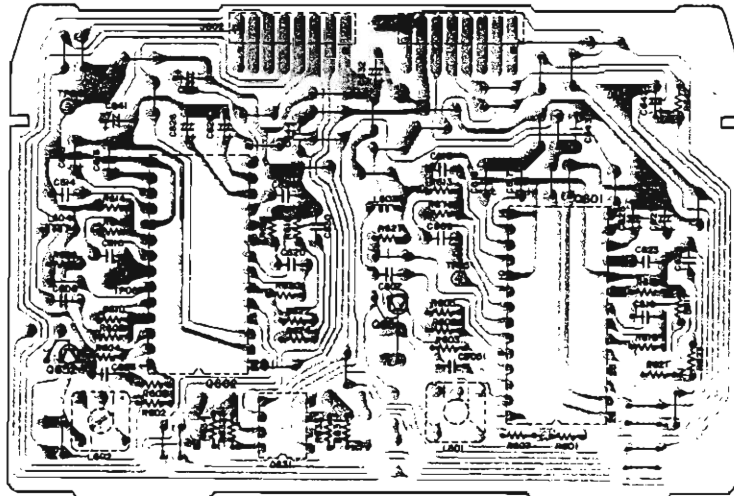

PJ03 - Audio Main P.W. Board

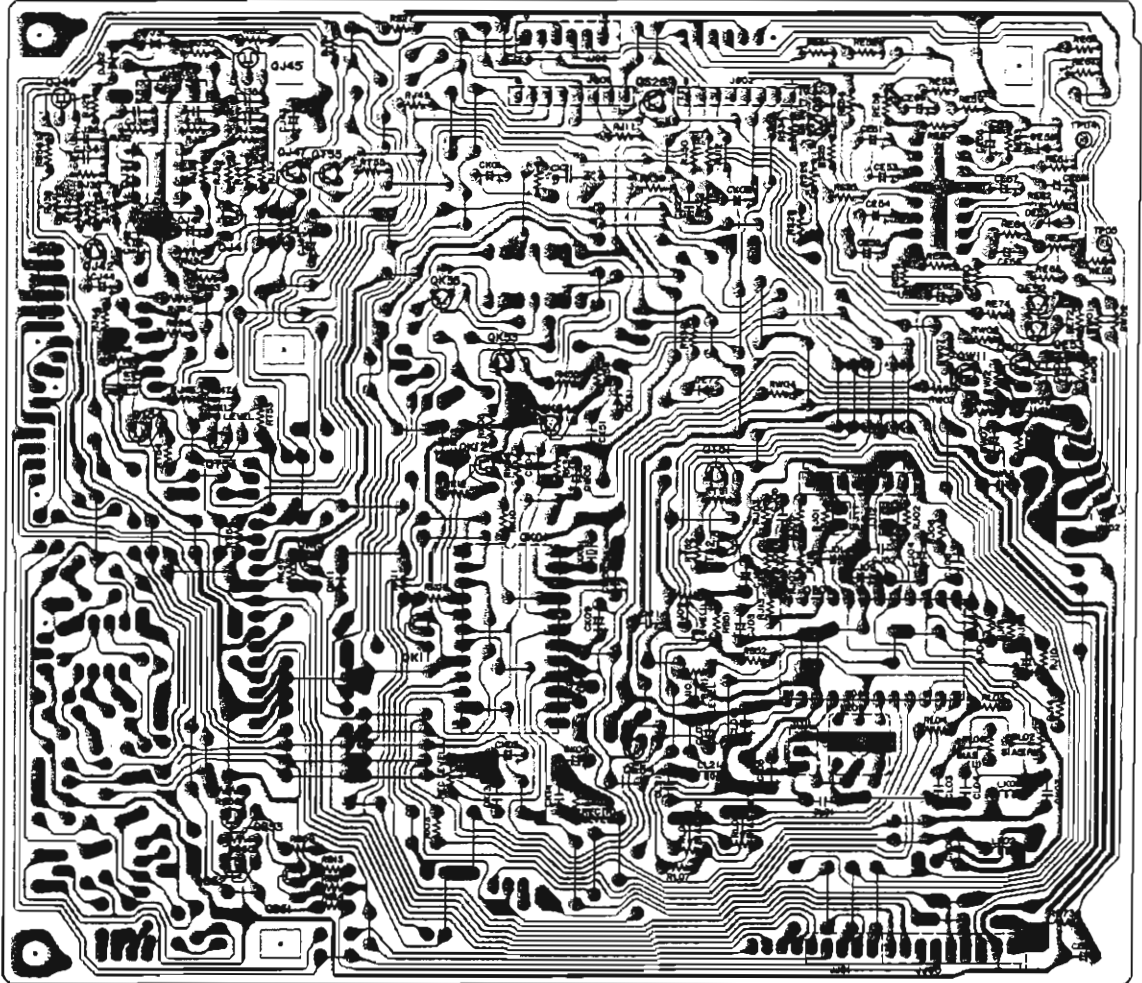

PU73 - Regulator



PU53 - Multi Connection P.W. Board

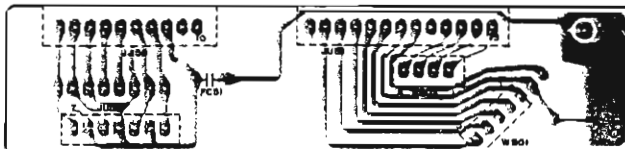

15. EXPLODED VIEW AND PARTS LIST

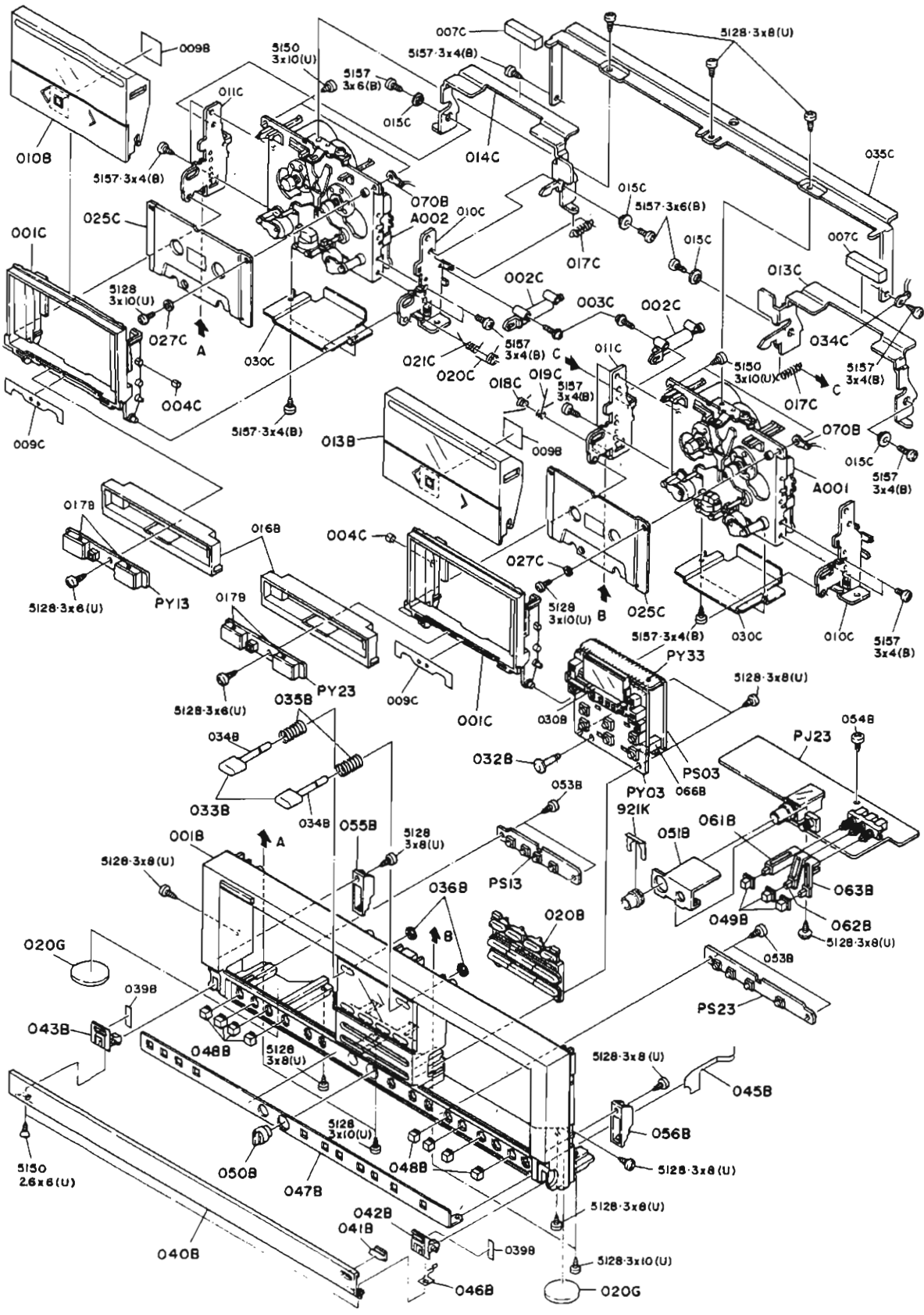

REF. DESIG.	PART NO.	DESCRIPTION
001B	4822 426 51184	Front Panel Assembly
010B	4822 459 20483	Cassette Window (A) Assembly
013B	4822 459 20484	Cassette Window (B) Assembly
020B	4822 410 25789	Button Assembly, Mecha
032B	4822 535 92013	Spacer
035B	4822 492 42164	Spring, Eject Button
036B	4822 532 11301	RG Ring, E Type $\phi 2.5$
040B	4822 454 20699	Escutcheon, Panel
041B	4822 412 20998	Knob, Panel
042B	4822 417 10983	Hinge (R), Panel
043B	4822 417 10984	Hinge (L), Panel
045B	4822 278 80275	Contact, Earth
046B	4822 278 80276	Contact, Earth
047B	4822 454 20701	Indicator, Button
048B	4822 410 25782	Button, Tact
049B	4822 410 25783	Button, Push
050B	4822 412 20997	Knob, Mix Level
051B	4822 532 21286	Retainer, Mic Jack
053B	4822 502 12115	B.T. Screw 83 x 6
054B	4822 502 12355	B.T. Screw 83 x 8
055B	4822 526 50096	Click (L)
056B	4822 526 50097	Click (R)
061B	4822 403 53185	Joint, Push Button
062B	4822 403 53186	Joint, Push Button
063B	4822 403 53187	Joint, Push Button
070B	4822 323 10103	Lub, Earth
001C	4822 459 20391	Door Assembly, Cassette Holder
002C	4822 464 50528	Dumper
003C	4822 502 12557	Screw, Dumper
004C	4822 492 63414	Leaf Spring, Holder Lock
013C	4822 403 53188	Hook (R), Eject
014C	4822 403 53189	Hook (L), Eject
017C	4822 492 32672	Spring, Eject Hook
018C	4822 492 41643	Spring, Door Open
019C	4822 492 41644	Spring, Cassette Open
020C	4822 492 42165	Spring, Door Open
021C	4822 492 42166	Spring, Cassette Open
025C	4822 454 11477	Escutcheon, Mecha Cover
027C	4822 532 11388	T.L. Washer, OR
034C	4822 290 30276	Lug, Earth
020G	4822 462 41142	Leg, Front
921K	4822 462 41037	Stopper, Headphone Jack
A001	4822 464 50666	Mechanism Assembly, Rec/Play
A002	4822 464 50667	Mechanism Assembly, Play

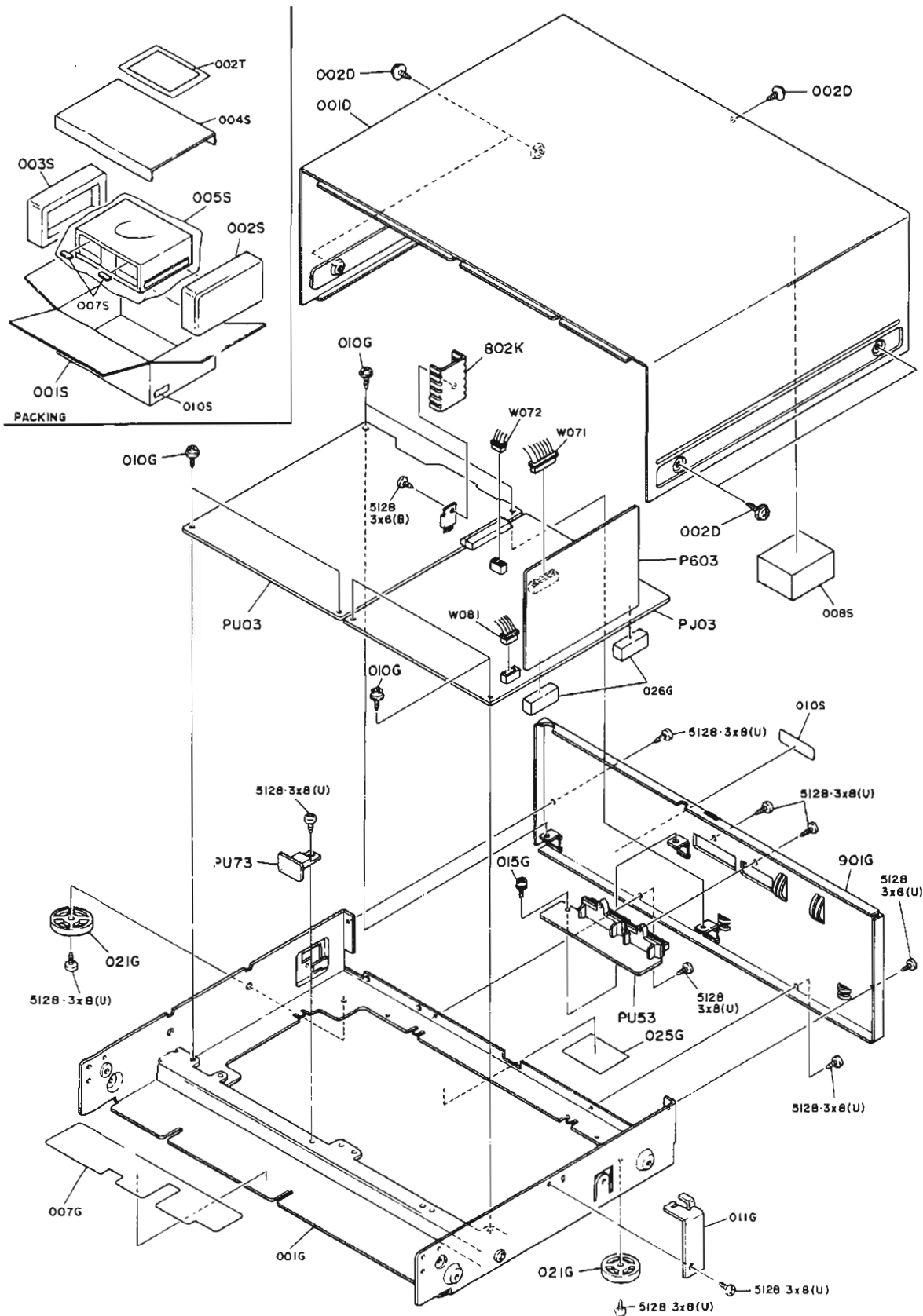

REF. DESIG.	PART NO.	DESCRIPTION
001D	4822 426 40367	Lid, Top Cover
002D	4822 502 12355	B.T. Screw B3 x 8
010G	4822 502 12355	B.T. Screw B3 x 8
015G	4822 502 12355	B.T. Screw B3 x 8
021G	4822 462 41143	Leg, Rear
025G	4822 600 70229	Label, Caution
901G	4822 426 20111	Rear Panel Assembly (N)
	4822 426 20112	Rear Panel Assembly (E)
802K	4822 255 40532	Heatsink (Q807)
		PACKING
001S	4822 600 70466	Packing Case (N)
002S	4822 600 70473	Cushion (R)
005S	4822 600 70347	Polyethylene Sheet

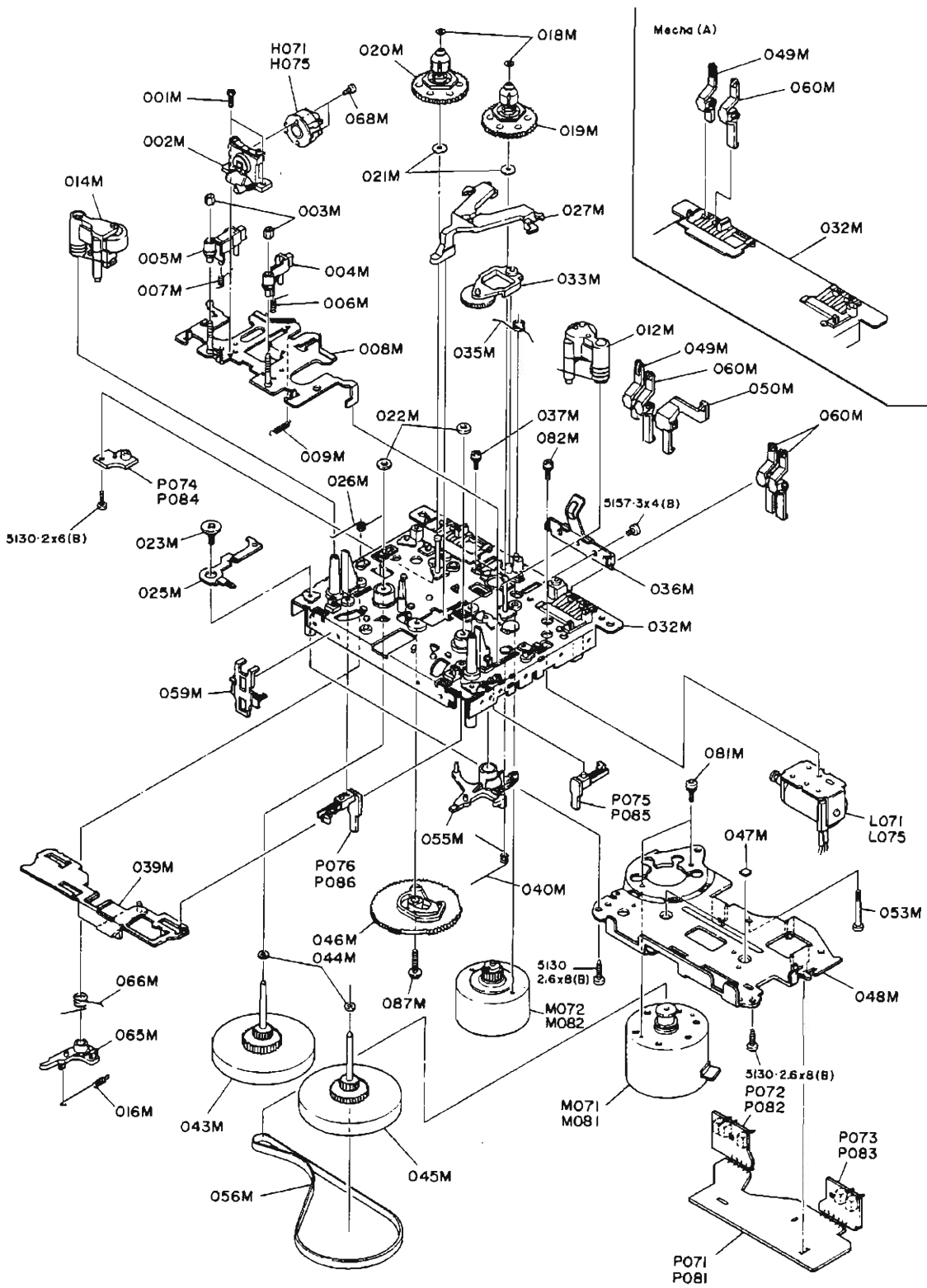

REF. DESIG.	PART NO.	DESCRIPTION
001M	4822 502 12149	L. Washer Screw L2 x 5
002M	4822 464 50575	Bracket, Head (Mecha B)
	4822 403 53191	Bracket, Head (Mecha A)
003M	4822 505 10805	Nut, Tape Guide
004M	4822 403 30525	Guide (R), Tape
005M	4822 403 30526	Guide (L), Tape
006M	4822 492 41675	Spring (R), Tape Guide
007M	4822 492 41676	Spring (L), Tape Guide
008M	4822 464 50592	Chassis S, Head
009M	4822 492 41677	Spring, Head Chassis
012M	4822 403 40483	Pinch Roller S (R)
014M	4822 403 53225	Pinch Roller S (L)
016M	4822 492 41681	Spring, Turn Gear
018M	4822 535 71232	Spacer, Reel
019M	4822 528 10588	Table S, Supply
020M	4822 528 10589	Table S, Take-up
021M	4822 502 12167	Washer, Reel
022M	4822 535 71101	Spacer, Oil Fence
023M	4822 502 12922	Screw, Eject Lock Arm
025M	4822 403 40307	Arm, Eject Lock
026M	4822 492 41683	Spring, Eject Lock
027M	4822 403 52695	Lever, Hold
032M	4822 464 50683	Chassis S, Main
033M	4822 403 40306	Idler S
035M	4822 492 41684	Spring, Hold Lever
036M	4822 492 41689	Leaf Spring, Cassette Hold
037M	4822 502 12427	L. Washer Screw L2.6 x 6
039M	4822 404 20944	Lever S, Slide Board
040M	4822 492 32758	Spring, Slide Board
043M	4822 528 60308	Flywheel, REVS
044M	4822 532 11398	Washer
045M	4822 528 60323	Flywheel, FWD
046M	4822 522 32357	Gear, Cam
047M	4822 535 71233	Spacer, Flywheel
048M	4822 403 53224	Bracket, Flywheel
049M	4822 403 52696	Lever, Pack
050M	4822 403 52697	Lever, Metal (Mecha B)
053M	4822 502 12923	Screw, Earth
055M	4822 403 53223	Arm S, Play
056M	4822 358 30794	Belt, Main
059M	4822 256 90897	Holder, Read
060M	4822 403 52698	Lever, Anti Rec
065M	4822 403 40482	Arm, Direction
066M	4822 492 32759	Spring
068M	4822 502 12467	P.H.M. Screw P1.4 x 5
081M	4822 532 11594	L. Washer Screw L2.6 x 3
082M	4822 532 11594	L. Washer Screw L2.6 x 3
087M	4822 502 12892	Screw, Cam Gear

REF. DESIG.	PART NO.	DESCRIPTION
H071	4822 249 10328	Head, Rotary; R-P/Erase (Mecha B)
H075	4822 249 30107	Head, Rotary; Play (Mecha A)
L071	4822 157 53126	Solenoid Coil (Mecha B)
L081	4822 157 53126	Solenoid Coil (Mecha A)
M071	4822 361 60458	D.C. Motor, Main (Mecha B)
M072	4822 361 60457	D.C. Motor, F/R (Mecha B)
M081	4822 361 60458	D.C. Motor, Main (Mecha A)
M082	4822 361 60436	D.C. Motor, F/R (Mecha A)
		(MECHA-B)
J071	4822 265 10059	Jack, 8P
J072	4822 265 10064	Jack, 7P
J073	4822 265 10062	Jack, 3P
J078	4822 265 10214	Jack, 4P
J079	4822 265 10216	Jack, 4P
Q071	4822 130 10023	Photo Unit
S071	4822 277 21151	Mini Switch, Play
S072	4822 277 21151	Mini Switch, Direction
S073	4822 276 12258	Push Switch, Cassette
S074	4822 276 12258	Push Switch, Anti Rec
S075	4822 276 12258	Push Switch, Metal
S076	4822 276 12258	Push Switch, CrO ₂
S077	4822 276 12258	Push Switch, REV Anti Rec
		(MECHA-A)
J075	4822 265 10064	Jack, 7P
J076	4822 265 10061	Jack, 5P
J077	4822 265 10062	Jack, 3P
J088	4822 265 10214	Jack, 4P
J089	4822 265 10215	Jack, 4P
Q081	4822 130 10023	Photo Unit
S081	4822 277 21151	Mini Switch, Play
S082	4822 277 21151	Mini Switch, Direction
S083	4822 276 12258	Push Switch, Cassette
S086	4822 276 12258	Push Switch, CrO ₂

16. ELECTRICAL PARTS LIST

ASSIGNMENT OF COMMON PARTS CODES.

RESISTOR

R*:** (1) GD05 --- 140, Carbon film fixed resistor, ±5%, 1/4W

R*:** (2) GD05 --- 180, Carbon film fixed resistor, ±5%, 1/6W

① — Resistance value

Examples

① Resistance value

0.1Ω...001	10Ω...100	1kΩ...102	100kΩ...104
0.5Ω...005	18Ω...180	2.7kΩ...272	680kΩ...684
1Ω...010	100Ω...10T	10kΩ...103	1MkΩ...105
6.8Ω...068	390Ω...391	22kΩ...223	4.7MkΩ...475

(Note) Please distinguish 1/4W from 1/6W by the shape of parts used actually.

C***: CERAMIC CAP.

(1) DD1 --- 370, Ceramic condenser
Disc type
Temp. coeff. P350 ~ N1000, 50V

① ②
Capacity value
Tolerance

Examples

① Tolerance (Capacity deviation)

±0.25pF...0
±0.5pF...1
±5%...5

* Tolerance of COMMON PARTS handled here are as follows:

0.5pF ~ 5pF...±0.25pF
6pF ~ 10pF...±0.5pF
12pF ~ 560pF...±5%

② Capacity value

0.5pF...005 3pF...030 100pF...101
1pF...010 10pF...100 220pF...221
1.5pF...015 47pF...470 560pF...561

C***: CERAMIC CAP.

(1) DK16 --- 300, High dielectric constant ceramic condenser
Disc type
Temp. chara. 2B4, 50V

①
Capacity value

Example

② Capacity value

100pF...101 1000pF...102 10000pF...103
470pF...471 2200pF...222

C***: ELECTROLY CAP. ($\frac{\square}{\square}$), FILM CAP. ($\frac{\square}{\square}$)

(1) EA --- 10, Electrolytic condenser
One-way lead type, Tolerance ±20%

① ②
Dielectric strength
Capacity value

Examples

① Capacity value

0.1μF...104	4.7μF...475	100μF...107
0.33μF...334	10μF...106	330μF...337
1μF...105	22μF...226	1100μF...108
		2200μF...228

② Working voltage

6.3V...006 25V...025
10V...010 35V...035
16V...016 50V...050

(2) DF15 --- 350, Plastic film condenser

One-way type, Mylar ±5% 50V

①
Capacity value

Examples

① Capacity value

0.001μF (1000pF)...102	0.1μF...104
0.0018μF...182	0.56μF...564
0.01μF...103	1μF...105
0.015μF...153	

REF. DESIG.	PART NO.	DESCRIPTION
		PJ03-AUDIO MAIN CIRCUIT BOARD
CF03	4822 122 32486	Ceramic 0.01μF +80% -20%
CF06	4822 122 32486	Ceramic 0.01μF +80% -20%
		PJ03-CAPACITORS
CJ01	4822 121 42713	Film 680pF ±5%
CJ02	4822 121 42713	Film 680pF ±5%
CJ31	4822 121 42327	Film 470pF ±5%
CJ32	4822 121 42327	Film 470pF ±5%
CK11	4822 122 32486	Ceramic 0.01μF +80% -20%
CK51	4822 122 32486	Ceramic 0.01μF +80% -20%
CL01	4822 121 42791	Film 4700pF ±5%
CL03	4822 121 42344	Film 220pF ±5%
CL04	4822 121 42344	Film 220pF ±5%
CL21	4822 122 32486	Ceramic 0.01μF +80% -20%
CW51	4822 122 32486	Ceramic 0.01μF +80% -20%
		PJ03-RESISTORS
RE73	4822 111 41137	180Ω ±5% 1/4W
RJ09	4822 100 11041	10KΩ, Trimming
RJ10	4822 100 11041	10KΩ, Trimming
RJ47	4822 100 11041	10KΩ, Trimming
RJ48	4822 100 11041	10KΩ, Trimming
RK01	4822 100 20545	22KΩ, Trimming
RK02	4822 100 20545	22KΩ, Trimming
RL01	4822 100 11042	47KΩ, Trimming
RL02	4822 100 11042	47KΩ, Trimming
RL05	4822 100 11041	10KΩ, Trimming
RL06	4822 100 11041	10KΩ, Trimming
		PJ03-SEMICONDUCTORS
DE51	4822 130 33305	Diode 1SS133, etc.
DE52	4822 130 33305	Diode 1SS133, etc.
DJ31	4822 130 33305	Diode 1SS133, etc.
DJ32	4822 130 33305	Diode 1SS133, etc.
DK11	4822 130 33305	Diode 1SS133, etc.
DK51	4822 130 33305	Diode 1SS133, etc.
QB51	4822 130 42483	Transistor 2SC536SP(F, G), etc.
QB52	4822 130 42483	Transistor 2SC536SP(F, G), etc.
QB53	4822 130 42483	Transistor 2SC536SP(F, G), etc.
QE51	4822 209 82434	IC BA343
QE52	4822 130 42483	Transistor 2SC536SP(F, G), etc.
QE53	4822 130 42483	Transistor 2SC536SP(F, G), etc.
QE54	4822 130 42483	Transistor 2SC536SP(F, G), etc.
QJ31	4822 209 81565	IC NJM2041DD
QJ41	4822 130 42483	Transistor 2SC536SP(F, G), etc.
QJ42	4822 130 42483	Transistor 2SC536SP(F, G), etc.
QJ45	4822 130 42836	F.E.T.
QJ46	4822 130 42836	F.E.T.
QJ47	4822 130 42483	Transistor 2SC536SP(F, G), etc.
QK01	4822 209 70379	IC TDD1601
QK11	4822 130 42483	Transistor 2SC536SP(F, G), etc.
QK12	4822 130 42483	Transistor 2SC536SP(F, G), etc.
QK13	4822 130 42715	Transistor 2SA608SP(F, G), etc.
QK53	4822 130 42483	Transistor 2SC536SP(F, G), etc.
QK54	4822 130 42483	Transistor 2SC536SP(F, G), etc.
QL01	4822 209 70378	IC TDA1600

REF. DESIG.	PART NO.	DESCRIPTION
QS25	4822 130 42483	Transistor 2SC536SP(F, G), etc.
QS26	4822 130 42483	Transistor 2SC536SP(F, G), etc.
QT51 }	4822 130 42483	Transistor 2SC536SP(F, G), etc.
QT55		
QW11	4822 130 42483	Transistor 2SC536SP(F, G), etc.
QW12	4822 130 42483	Transistor 2SC536SP(F, G), etc.
PJ03-MISCELLANEOUS		
JJ01	4822 265 30473	Plug, 6P
JJ11	4822 265 20311	Plug, 2P
JJ12	4822 265 20311	Plug, 2P
JJ31	4822 265 30482	Plug, 4P
JL01	4822 265 10078	Plug, 3P
JJ90	4822 267 50681	Jack, 9P
JJ91	4822 267 40727	Jack, 5P
J691	4822 265 10061	Jack, 5P
LK01	4822 152 20564	Choke Coil, 22mH
LK02	4822 152 20564	Choke Coil, 22mH
LL01	4822 146 10184	OSC Transformer
LL21	4822 152 20622	Choke Coil, 22mH
WJ52	4822 323 10059	Jumper Lead, 7P
WJ92	4822 323 10099	Jumper Lead, 6P
XK01	4822 242 71533	Ceramic Vibrator, CSB500E
PJ23-NR SWITCH/MIX MIC AMP CIRCUIT BOARD		
PJ23-CAPACITORS		
CE01	4822 122 32486	Ceramic 0.01 μ F +80% -20%
CE03	4822 122 40103	Ceramic 5pF \pm 0.25pF
CE12	4822 122 32486	Ceramic 0.01 μ F +80% -20%
PJ23-RESISTOR		
RE06	4822 100 20616	10K Ω (A), Variable
PJ23-SEMICONDUCTORS		
QE01 }	4822 130 42483	Transistor 2SC536SP(F, G), etc.
QE04		
PJ23-MISCELLANEOUS		
JE01	4822 267 30756	Jack, Mix Mic
JJ92	4822 265 10063	Jack, 6P
SS05	4822 276 12221	Push Switch, NR ON/OFF
SS06	4822 276 12221	Push Switch, Dolby B/C
SS35	4822 276 12221	Push Switch, Sync Rec ON/OFF
WS94	4822 323 10088	Jumper lead, 4P
W691	4822 323 10094	Jumper Lead, 5P

REF. DESIG.	PART NO.	DESCRIPTION
PS03-WIRE CONNECT CIRCUIT BOARD		
PS03-SEMICONDUCTORS		
DS61 }	4822 130 33305	Diode 1SS133, etc.
DS66		
DY61 }	4822 130 33305	Diode 1SS133, etc.
DY64		
QY61	4822 130 42715	Transistor 2SA608SP(F, G), etc.
QY62	4822 130 43191	Transistor 2SC1741(Q, R)
QY64	4822 130 43191	Transistor 2SC1741(Q, R)
QY65	4822 130 42715	Transistor 2SA608SP(F, G), etc.
QY66	4822 130 43191	Transistor 2SC1741(Q, R)
QY67	4822 130 42715	Transistor 2SA608SP(F, G), etc.
QY68	4822 130 43191	Transistor 2SC1741(Q, R)
PS03-MISCELLANEOUS		
JS91	4822 265 10064	Jack, 7P
JS95	4822 265 10112	Jack, 5P
JS96	4822 265 10112	Jack, 5P
PS13-KEY SWITCH CIRCUIT BOARD		
SS36	4822 276 11559	Push Switch, Memory
SS37	4822 276 11559	Push Switch, Counter Reset
SS38	4822 276 11559	Push Switch, QMS
SS45	4822 276 11559	Push Switch, Reverse Mode
WS92	4822 323 10239	Jumper Lead, 6P
PS23-KEY SWITCH CIRCUIT BOARD		
SS34	4822 276 11559	Push Switch, Blank Skip
SS51	4822 276 11559	Push Switch, N-Speed Dubbing
SS52	4822 276 11559	Push Switch, H-Speed Dubbing
SS53	4822 276 11559	Push Switch, Continuous Play
WS93	4822 323 10154	Jumper Lead 7P
PU03-LOGIC MAIN CIRCUIT BOARD		
PU03-CAPACITORS		
CB03	4822 122 40491	Ceramic 0.022 μ F +80% -20%
CB04	4822 122 40491	Ceramic 0.022 μ F +80% -20%
CB05	4822 122 31626	Ceramic 100pF \pm 5%
CB06	4822 122 40491	Ceramic 0.022 μ F +80% -20%
CF51	4822 122 32486	Ceramic 0.01 μ F +80% -20%
CF81	4822 122 32486	Ceramic 0.01 μ F +80% -20%

REF. DESIG.	PART NO.	DESCRIPTION
CM81	4822 122 32486	Ceramic 0.01 μ F +80% -20%
CM82	4822 122 32486	Ceramic 0.01 μ F +80% -20%
CM85	4822 122 32486	Ceramic 0.01 μ F +80% -20%
CM86	4822 122 32486	Ceramic 0.01 μ F +80% -20%
CU03 }	4822 122 32486	Ceramic 0.01 μ F +80% -20%
CU05		
CU06	4822 122 32486	Ceramic 0.01 μ F +80% -20%
CU07	4822 122 32486	Ceramic 0.01 μ F +80% -20%
CU08	4822 122 32486	Ceramic 0.01 μ F +80% -20%
C801	4822 122 32486	Ceramic 0.01 μ F +80% -20%
C811	4822 122 40306	Ceramic 0.047 μ F +80% -20%
C813	4822 122 32486	Ceramic 0.01 μ F +80% -20%
PU03-RESISTORS		
RB21	4822 111 41137	180 Ω \pm 5% $\frac{1}{2}$ W
RM03	4822 100 20524	4.7K Ω , Trimming
RM06	4822 100 11041	10K Ω , Trimming
RM13	4822 100 20524	4.7K Ω , Trimming
RM16	4822 100 11041	10K Ω , Trimming
RQ33	4822 116 60444	180 Ω \pm 5% 1W, Metal
RQ43	4822 116 60444	180 Ω \pm 5% 1W, Metal
Δ R801	4822 116 60306	10 Ω \pm 5% $\frac{1}{2}$ W, Fusible
Δ R802	4822 116 60306	10 Ω \pm 5% $\frac{1}{2}$ W, Fusible
R804	4822 111 91403	3.3 Ω \pm 5% 1/6W
R805	4822 116 60306	10 Ω \pm 5% $\frac{1}{2}$ W, Fusible
R821	4822 111 41284	68 Ω \pm 5% $\frac{1}{2}$ W
R824	4822 116 60355	33 Ω \pm 5% 1W
R825	4822 111 41132	22 Ω \pm 5% 1W
GU01	4822 111 91185	10K Ω x4, Alloy
GU02	4822 111 91395	10K Ω x8, Alloy
GU03	4822 111 91185	10K Ω x4, Alloy
GU11	4822 111 91186	10K Ω x5, Alloy
GU31	4822 111 91186	10K Ω x5, Alloy
PU03-SEMICONDUCTORS		
DM81	4822 130 33759	Zener 4.7V
DM85	4822 130 33759	Zener 4.7V
DQ31	4822 130 32508	Diode 1SR35-200A
DQ41	4822 130 32508	Diode 1SR35-200A
DR01	4822 130 33305	Diode 1SS133, etc.
DU01	4822 130 80317	Zener RD5.1JB2
DU52	4822 130 33305	Diode 1SS133, etc.
DU53	4822 130 33305	Diode 1SS133, etc.
DU61 }	4822 130 80091	Zener 12V
DU65		
DY65	4822 130 33305	Diode 1SS133, etc.
D803	4822 130 32508	Diode 1SR35-200A
Δ D805	4822 130 32508	Diode 1SR35-200A
Δ D806	4822 130 32508	Diode 1SR35-200A
Δ D809	4822 130 32508	Diode 1SR35-200A
D811	4822 130 33305	Diode 1SS133, etc.
D812	4822 130 33948	Zener 5.6V
Δ D821	4822 130 32508	Diode 1SR35-200A
D822	4822 130 80116	Zener 24V
D824	4822 130 80272	Zener 5.1V

REF. DESIG.	PART NO.	DESCRIPTION
QB01	4822 209 83706	IC BA335
QB02 }	4822 130 42483	Transistor 2SC536SP(F, G), etc.
QB06		
QM01	4822 130 42715	Transistor 2SA608SP(F, G), etc.
QM02	4822 130 60174	Transistor 2SD1379
QM11	4822 130 42715	Transistor 2SA608SP(F, G), etc.
QM12	4822 130 60174	Transistor 2SD1379
QM81	4822 209 82059	IC BA6109
QM82	4822 130 42715	Transistor 2SA608SP(F, G), etc.
QM85	4822 209 82059	IC BA6109
QM86	4822 130 42715	Transistor 2SA608SP(F, G), etc.
QQ31	4822 130 60173	Transistor 2SC2060(Q, R)
QQ32	4822 130 43191	Transistor 2SC1741(Q, R)
QQ33	4822 130 42483	Transistor 2SC536SP(F, G), etc.
QQ34	4822 130 42483	Transistor 2SC536SP(F, G), etc.
QQ41	4822 130 60173	Transistor 2SC2060(Q, R)
QQ42	4822 130 43191	Transistor 2SC1741(Q, R)
QQ43	4822 130 42483	Transistor 2SC536SP(F, G), etc.
QQ44	4822 130 42483	Transistor 2SC536SP(F, G), etc.
QR01	4822 130 42483	Transistor 2SC536SP(F, G), etc.
QR02	4822 130 42483	Transistor 2SC536SP(F, G), etc.
QR03	4822 130 42715	Transistor 2SA608SP(F, G), etc.
QU01	4822 209 71763	Microprocessor μ PD75206CW
QU05	4822 130 42715	Transistor 2SA608SP(F, G), etc.
QU11	4822 209 70386	IC LM6413E
QU31	4822 209 70386	IC LM6413E
QU41	4822 130 43191	Transistor 2SC1741(Q, R)
QU42	4822 130 43191	Transistor 2SC1741(Q, R)
QU43	4822 130 43191	Transistor 2SC1741(Q, R)
QU44	4822 130 43191	Transistor 2SC1741(Q, R)
QU51	4822 209 70381	IC DT5A124E
QU71	4822 130 42715	Transistor 2SA608SP(F, G), etc.
QY63	4822 130 42715	Transistor 2SA608SP(F, G), etc.
Δ Q807	4822 209 70385	IC L78MR05
PU03-MISCELLANEOUS		
JM01	4822 265 20311	Plug, 2P
JM11	4822 265 20311	Plug, 2P
JU90	4822 265 40602	Plug, 9P
JU91	4822 265 30542	Plug, 5P
JU92	4822 265 10059	Jack, 8P
JU93	4822 265 10059	Jack, 8P
JY91	4822 265 10059	Jack, 8P
JY92	4822 265 10105	Jack, 4P
W801	4822 323 10056	Jumper Lead, 7P
W802	4822 323 10081	Jumper Lead, 3P
W803	4822 323 10113	Jumper Lead, 5P
XU01	4822 242 71405	Ceramic Vibrator, CSB800K
XY02	4822 242 71774	Ceramic Vibrator, CST4.19MT

REF. DESIG.	PART NO.	DESCRIPTION
		PU53-MULTI CONNECTION CIRCUIT BOARD
JJ51	4822 266 30305	Terminal, 10P
JU51	4822 266 30306	Terminal, 13P
JU52	4822 265 10064	Jack, 7P
		PU73-REGULATOR CIRCUIT BOARD
Δ Q806	4822 209 82829	IC NJM78M15A
		PY03-KEY SW./LED INDICATOR CIRCUIT BOARD
DY05	4822 130 80327	L.E.D. LT3G8B
DY06	4822 130 80326	L.E.D. LT3D8B
DY34	4822 130 80326	L.E.D. LT3D8B
DY45	4822 130 80323	L.E.D. SLS-3103
DY51	4822 130 80326	L.E.D. LT3D8B
DY52	4822 130 80326	L.E.D. LT3D8B
DY53	4822 130 80326	L.E.D. LT3D8B
DY55	4822 130 80326	L.E.D. LT3D8B
DY56	4822 130 80326	L.E.D. LT3D8B
SS21	4822 276 11559	Push Switch, REC
SS23	4822 276 11559	Push Switch, Pause
SS24	4822 276 11559	Push Switch, REC Mute
SS25	4822 276 11559	Push Switch, FF
SS26	4822 276 11559	Push Switch, REW
SS27	4822 276 11559	Push Switch, Stop
SS41	4822 276 11559	Push Switch, FWD Play
SS42	4822 276 11559	Push Switch, REV Play
SS55	4822 276 11559	Push Switch, Deck A
SS56	4822 276 11559	Push Switch, Deck B
VY01	4822 130 90431	Display Unit
WS91	4822 323 10135	Jumper Lead, 7P
WY92	4822 323 10186	Jumper Lead, 4P
		PY13-CASSETTE LED M1 CIRCUIT BOARD
DY41	4822 130 80118	L.E.D. LN173WP68
DY43	4822 130 80324	L.E.D. LD-602MR
DY44	4822 130 80324	L.E.D. LD-602MR
WS95	4822 321 21419	Connective Cord, 5P
		PY23-CASSETTE LED M2 CIRCUIT BOARD
DY48	4822 130 80118	L.E.D. LN173WP68
DY49	4822 130 80324	L.E.D. LD-602MR
DY50	4822 130 80324	L.E.D. LD-602MR
WS96	4822 321 21419	Connective Cord, 5P

REF. DESIG.	PART NO.	DESCRIPTION
		P603-DOLBY B/C CIRCUIT BOARD
		P603-CAPACITORS
C617	4822 124 41188	Elect 0.68μF 50V
C618	4822 124 41188	Elect 0.68μF 50V
C627	4822 124 41188	Elect 0.68μF 50V
C628	4822 124 41188	Elect 0.68μF 50V
		P603-SEMICONDUCTORS
Q601	4822 209 83614	IC TEA0665
Q602	4822 209 83614	IC TEA0665
Q631	4822 209 80401	IC 4558D
		P603-MISCELLANEOUS
J601	4822 265 40544	Plug, 8P
J602	4822 265 40544	Plug, 8P
L601	4822 157 52461	M.P.X. Coil
L602	4822 157 52461	M.P.X. Coil
L603	4822 156 10842	Choke Coil, 36mH
L604	4822 156 10842	Choke Coil, 36mH

(W01-99)	Assembly and Wiring
(T01-99)	Adjustment
(X01-00)	Correction

TECHINICAL SPECIFICATIONS (DIN)

MODEL PM673

AUDIO SECTION

IHF Dynamic Power	
8 OHMS	75 W
POWER OUTPUT PER CHANNEL	
EIAJ 6 OHMS	65 W x 3
DIN 8 OHMS	50 W x 3
TOTAL HARMONIC DISTORTION	0.05 %
I.M. DISTORTION	0.05 %
DAMPING FACTOR 8 OHMS (1 kHz)	50

MM CARTRIDGE INPUT

Frequency Response (IEC)	±0.5 dB
Signal-to-Noise Ratio (IEC A weighted)	75 dB
Input Impedance	47 k ohms
Input Capacitance	200 pF
Input Sensitivity	3.0 mV

CD INPUT

Input Impedance	25 k ohms
Input Sensitivity	180 mV
Signal to Noise Ratio (IEC A weighted)	90 dB

OUTPUT VOLTAGE

VCR Out [7.75 mV PHONO (MM) Input]	500 mV
--	--------

OUTPUT IMPEDANCE

VCR Out (Source PHONO)	1 k ohms
------------------------------	----------

GENERAL

Power Requirements	T version	240 V AC, 50 Hz
	N version	220/240 V AC, 50/60 Hz
	E version	110 ~ 120/220 ~ 240 V AC, 50/60 Hz

Dimensions

Panel Width	360 mm
Panel Height	120 mm
Depth	300 mm

Weight

Unit Alone	11.0 kg
------------------	---------

MODEL ST673/ST673L

FM TUNER SECTION

Frequency Range	87.5 ~ 108 MHz
Usable Sensitivity	
Mono (S/N 26 dB, 75 ohms)	0.9 μ V
Stereo (S/N 46 dB, 75 ohms)	25 μ V
Alternate Channel Selectivity 98 MHz (W/N)	65 dB
Image Response Rejection	60 dB
IF Rejection	80 dB
Spurious Response Rejection	75 dB
AM Suppression	60 dB
Signal-to-Noise Ratio	
Unweighted	
Mono	75 dB
Stereo	70 dB
Weighted	
Mono	78 dB
Stereo	72 dB
Pilot Signal & Subcarrier Rejection	
19 kHz	50 dB
38 kHz	55 dB
Total Harmonic Distortion	
Mono (W/N)	0.1 %
Stereo (W/N)	0.2 %
Frequency Response	
30 Hz ~ 15 kHz	+0.5, -2.0 dB
Separation	
Stereo (W/N)	48 dB
Channel Balance	0.2 dB

MW TUNER SECTION

Frequency Range	531 ~ 1602 kHz
Usable Sensitivity 20 dB S/N 30% Mod., 999 kHz	400 μ V/m
Selectivity 999 kHz, \pm 9 kHz	35 dB
Image Rejection, 999 kHz	45 dB
IF Rejection, 999 kHz	70 dB
Signal-to-Noise Ratio, 999 kHz	52 dB
Total Harmonic Distortion, 999 kHz	0.3 %

LW TUNER SECTION

Frequency Range	152 ~ 282 kHz
Usable Sensitivity 20 dB S/N 30% Mod., 209 kHz	800 μ V
Image Rejection, 209 kHz	45 dB
IF Rejection, 209 kHz	65 dB
Signal-to-Noise Ratio, 209 kHz	50 dB

GENERAL

Power Requirement	N and T versions	110/120/220/240 V AC, 50/60 Hz
	E version	220/240 V AV, 50/60 Hz

Dimensions

Panel Width	360 mm
Panel Height	55 mm
Depth	300 mm

Weight

Unit Alone	3.0 kg
------------	--------

MODEL SD873

Style	Front load
Tape Drive System	Single Capstan Drive
Cartridge	Philips type compact cassette
Track System	Compatible Stereo 4-track 2-channel
Tape Speed	4.75 cm/sec
Heads	3 Head System
Composition	2 Rec/Play: Super Hard Metal Alloy
	Erase: Dual Gap Ferrite x 1
Motor	2 Motor System x 2
	Capstan: DC Servo Motor
	Mechanism: DC Motor
Overall Frequency Response at -20 dB	
Normal Tape	25 Hz ~ 17 kHz
CrO ₂ Tape	25 Hz ~ 19 kHz
Metal Tape	25 Hz ~ 20 kHz
Signal-to-Noise Ratio:	
Dolby B/C (ON)	64/73 dB
Dolby (OFF)	56 dB
Wow and Flutter	
DIN WTD	0.1 %
Outputs	
Line Level/Impedance	500 mV/2.2 k ohms
Input (Level at 0 VU)	
Line Sensitivity/Impedance	230 mV/40 k ohms
Mic Sensitivity/Impedance	0.6 mV/6 k ohms
Fast Rewind Time	95 sec. (C-60)
Fast Forward Time	95 sec. (C-60)
Power Requirements	
N and T versions	220/240 V AC, 50/60 Hz
E version	110/120/220/240 V AC, 50/60 Hz
Power Consumption at Rated Output, both Channels Operating	25 W
Dimensions	
Panel Width	360 mm
Panel Height	120 mm
Depth	300 mm
Weight	4.8 kg

MARANTZ SERVICE BULLETIN		Date: 21-09-1988	Model: PM 673
		Page: 1	NBR: 88-012
Circulation:	Application	Subject:	
for information customer complaint in case of service mandatory	W100001 N220001 T100001 A100001 E210001	Change of microprocessor	
		Int. ref: PM673-005	

	Old	Changed Into
QU01	uPD75208CW/083 4822 209 71787	uPD75208CW/G-134 4822 209 73844
CN01	470 uF	220 uF/16V 4822 124 41153
RN04	1 MOhm	580 k 4822 116 52298
RN59	1 MOhm	470 k 4822 116 52285

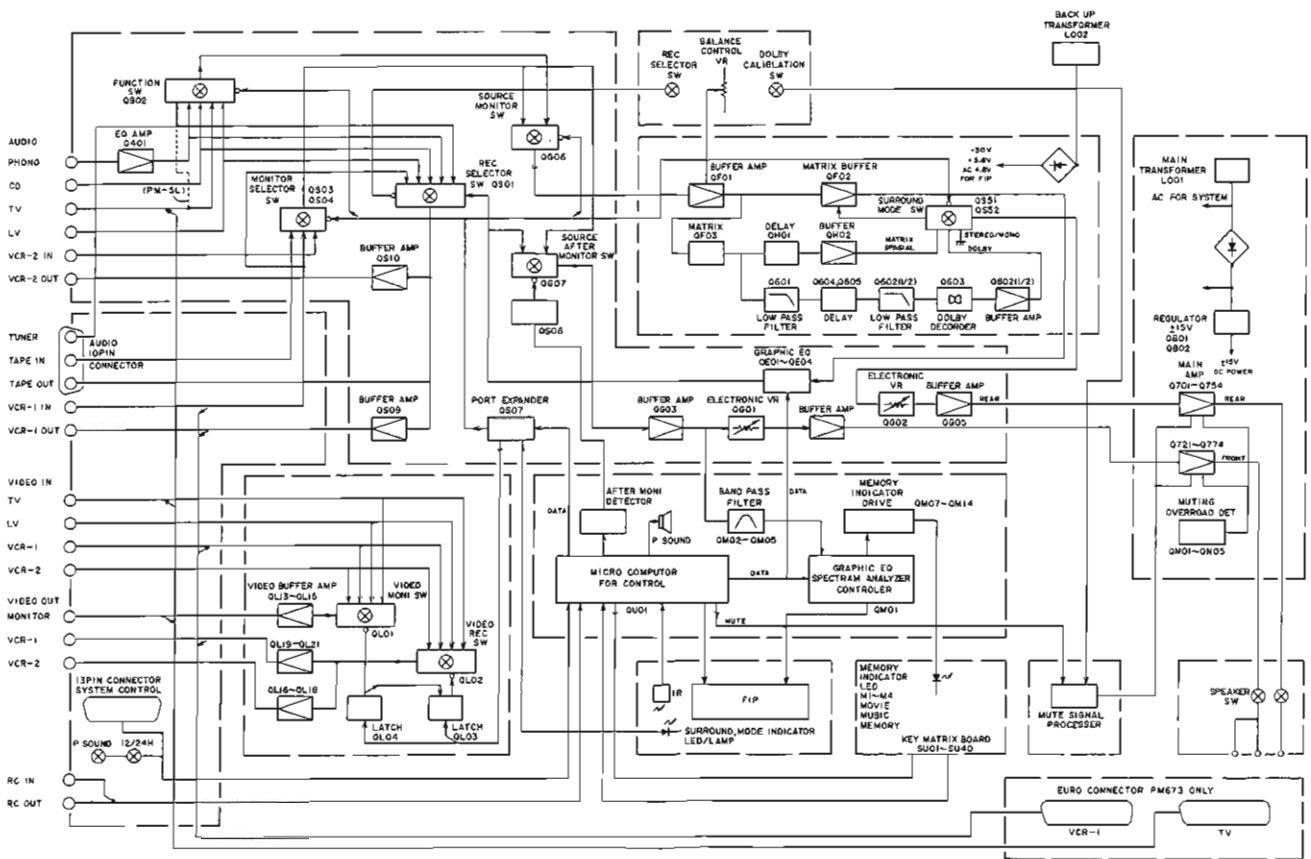

PM-5L/PM673

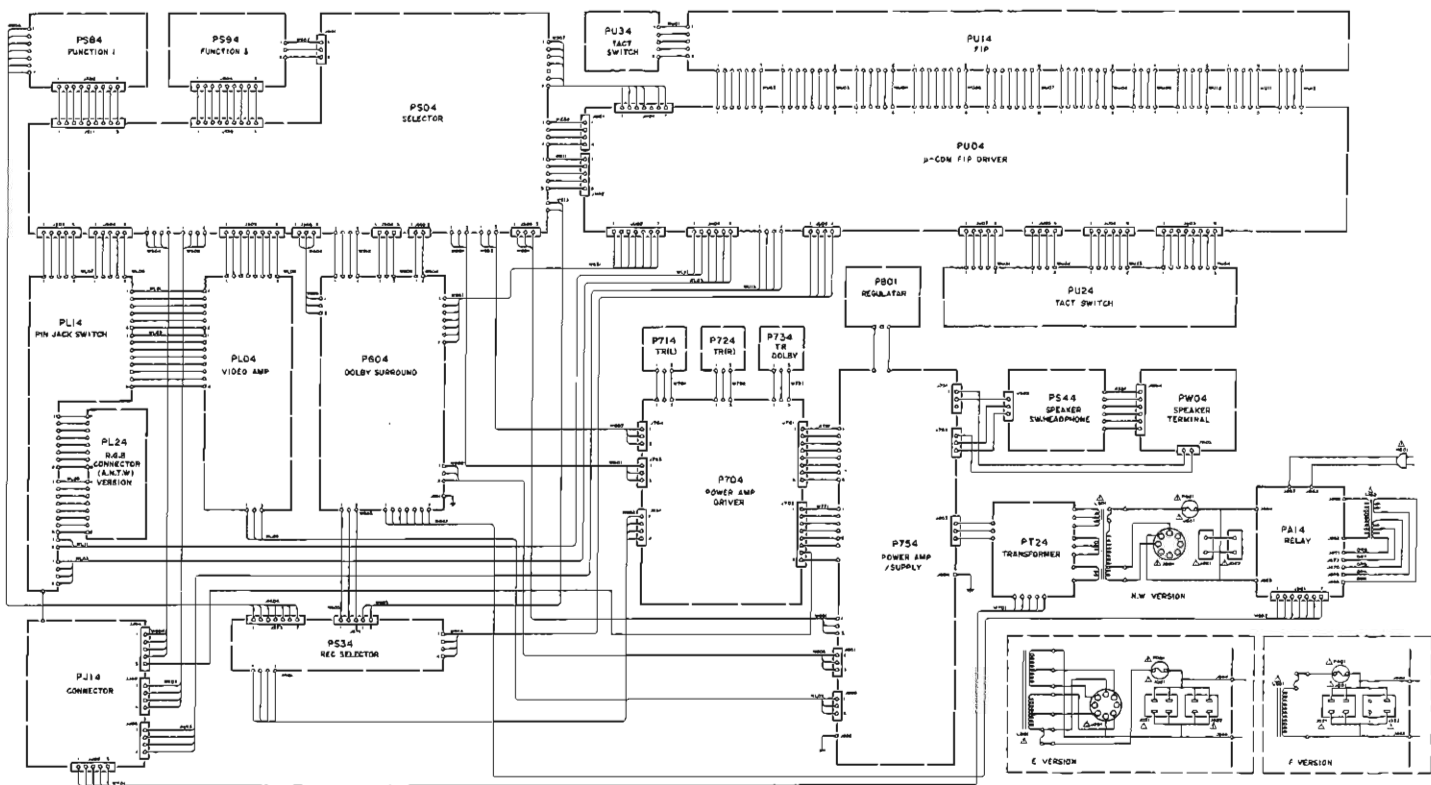

PM-5L/PM673

PU24 - TACT SWITCH

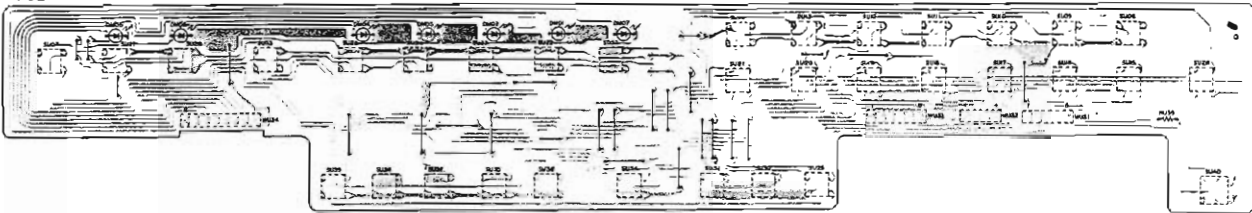

PU14 - FIP

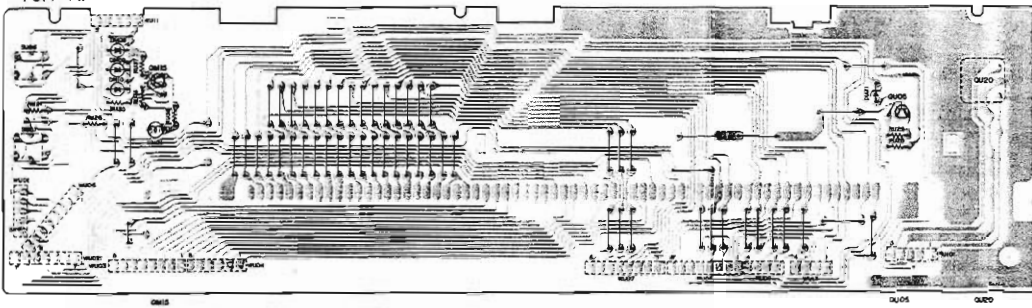

P754 - POWER AMP/SUPPLY

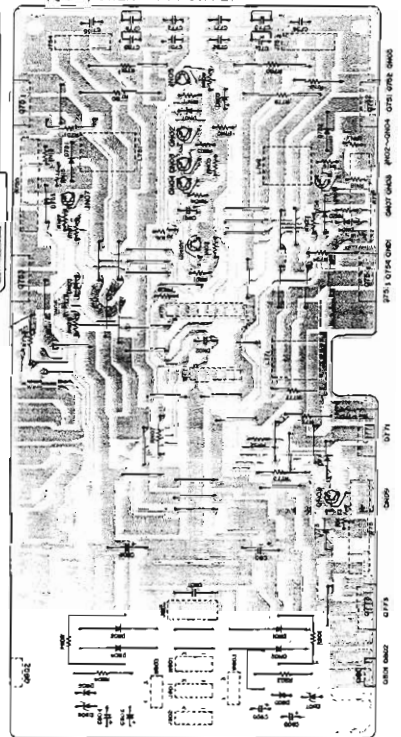

P604 - DOLBY SURROUND

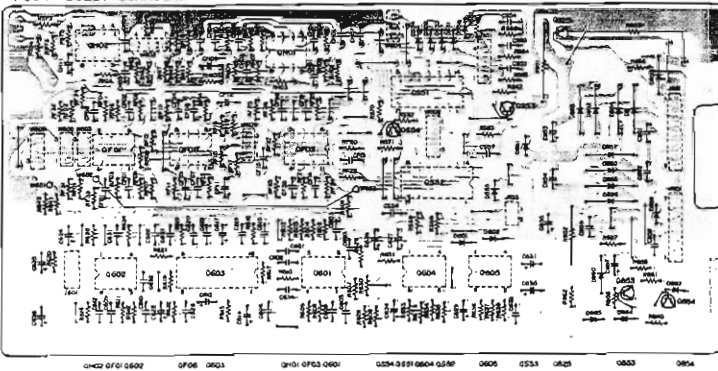

Power Switch (PS94)

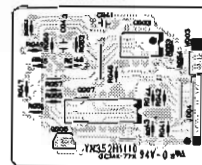

P714 - TR(L)



P724 - TR(R)



P734 - TR DOLBY



P801 - REG.



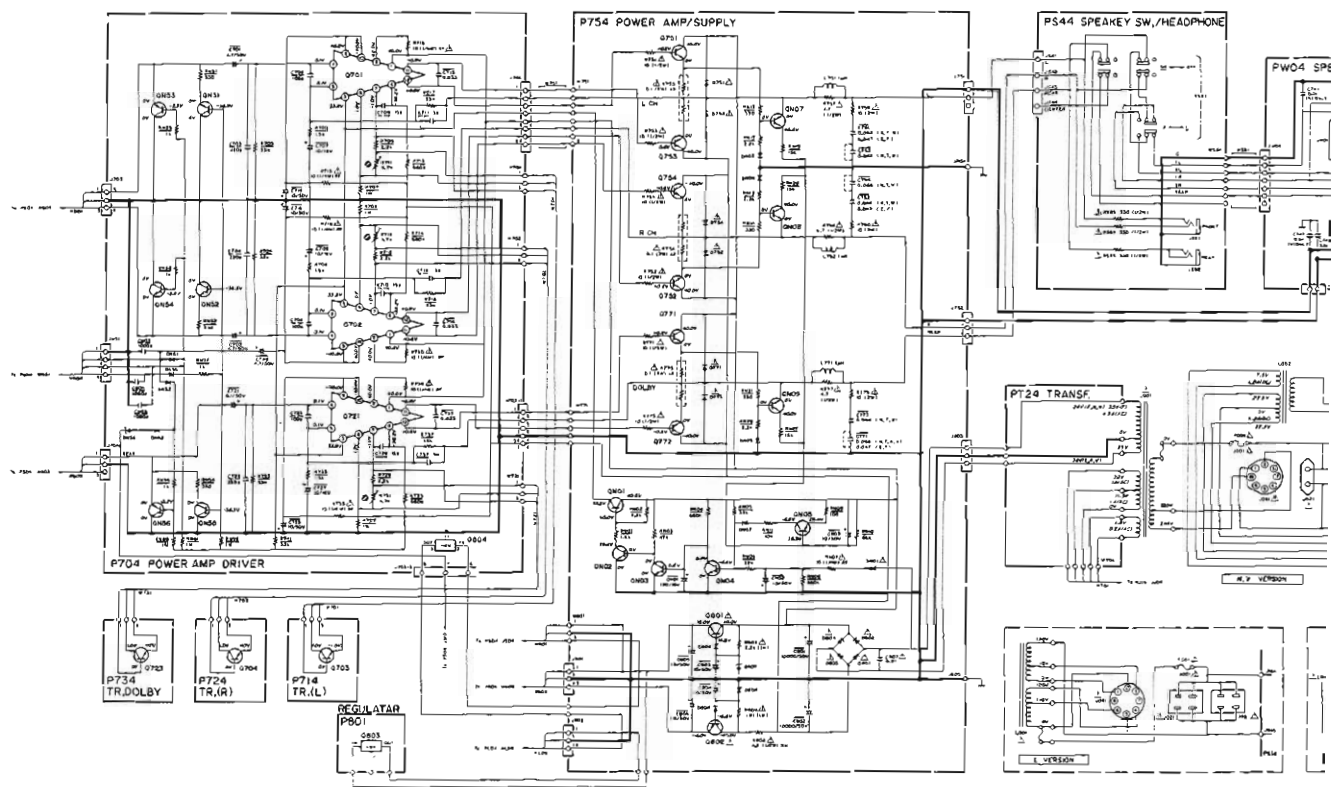

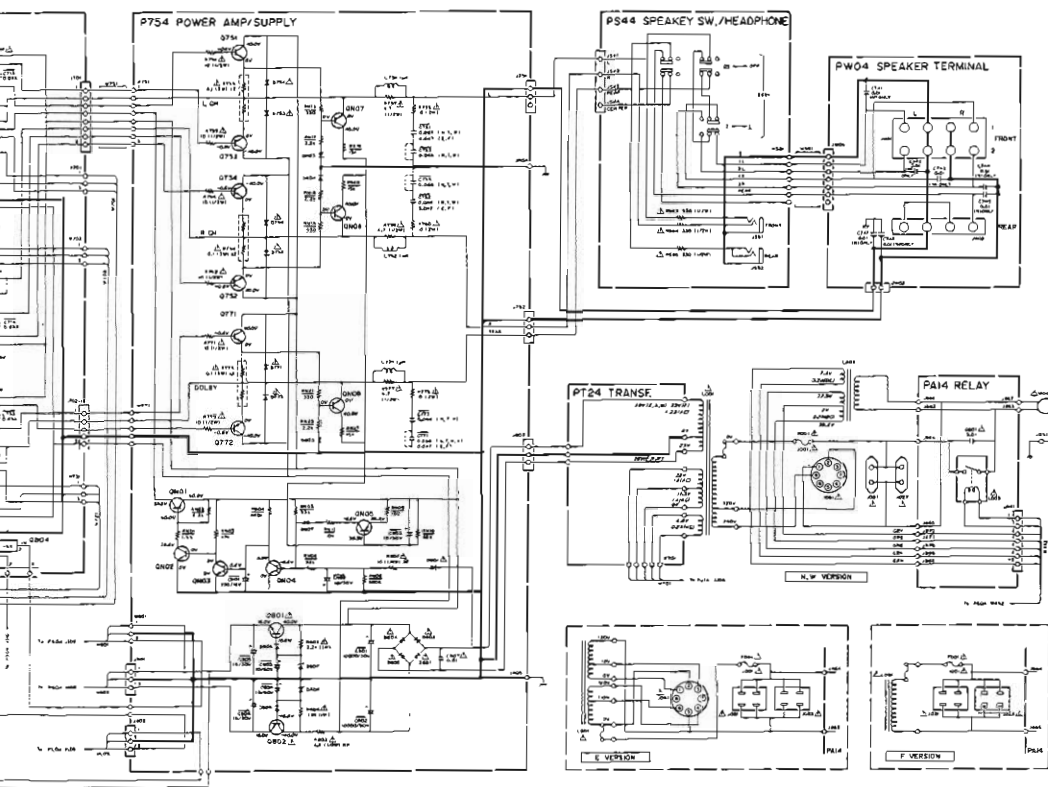

- | | | | | | | | | | | | | | | | | | | | | | | | |
|---|--|---|---|---------------------------------|------------------------------------|---------------------------------|-------------------------------------|--|--|-----------------------------------|---|---------------------------------|---|---|---------------------------------|------------------------------------|---------------------------------|-------------------------------------|--|--|-----------------------------------|---|---------------------------------|
| Q701-Q702-Q721
=C1014050
P/C12704 | Q703-Q704-Q723
=C15341110
P/C3418171 | Q751-Q752-Q771
=T1712180
250171415,P1 | Q773-Q774-Q772
=T1155180
259115512,P1 | Q801
=T1158250
2501285,P1 | Q802
=T11308200
254130800,P1 | Q803
=C13000090
N/JMT8M04 | Q804
=T10001000
R610000P/F,01 | Q805-Q807-Q809
=T1218250
25C2185,P1,P1 | Q803-Q804
=T13000100
P/C3385P/F,01 | Q805
=T1175200
254117507,P1 | Q805A-Q805B-Q806
=T13000100
P/C3385P/F,01 | Q806
=C13000090
N/JMT8M04 | Q701-Q702-Q771
=T1712180
250171415,P1 | Q773-Q774-Q772
=T1155180
259115512,P1 | Q801
=T1158250
2501285,P1 | Q802
=T11308200
254130800,P1 | Q803
=C13000090
N/JMT8M04 | Q804
=T10001000
R610000P/F,01 | Q805-Q807-Q809
=T1218250
25C2185,P1,P1 | Q803-Q804
=T13000100
P/C3385P/F,01 | Q805
=T1175200
254117507,P1 | Q805A-Q805B-Q806
=T13000100
P/C3385P/F,01 | Q806
=C13000090
N/JMT8M04 |
|---|--|---|---|---------------------------------|------------------------------------|---------------------------------|-------------------------------------|--|--|-----------------------------------|---|---------------------------------|---|---|---------------------------------|------------------------------------|---------------------------------|-------------------------------------|--|--|-----------------------------------|---|---------------------------------|

SCHEMATIC DIAGRAM OF PM-5L (4/4)

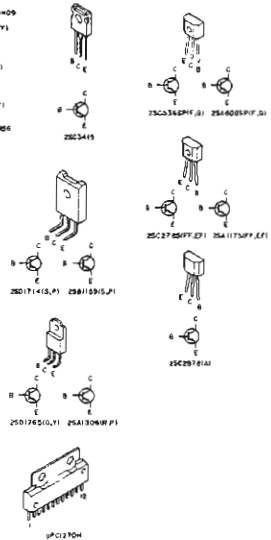

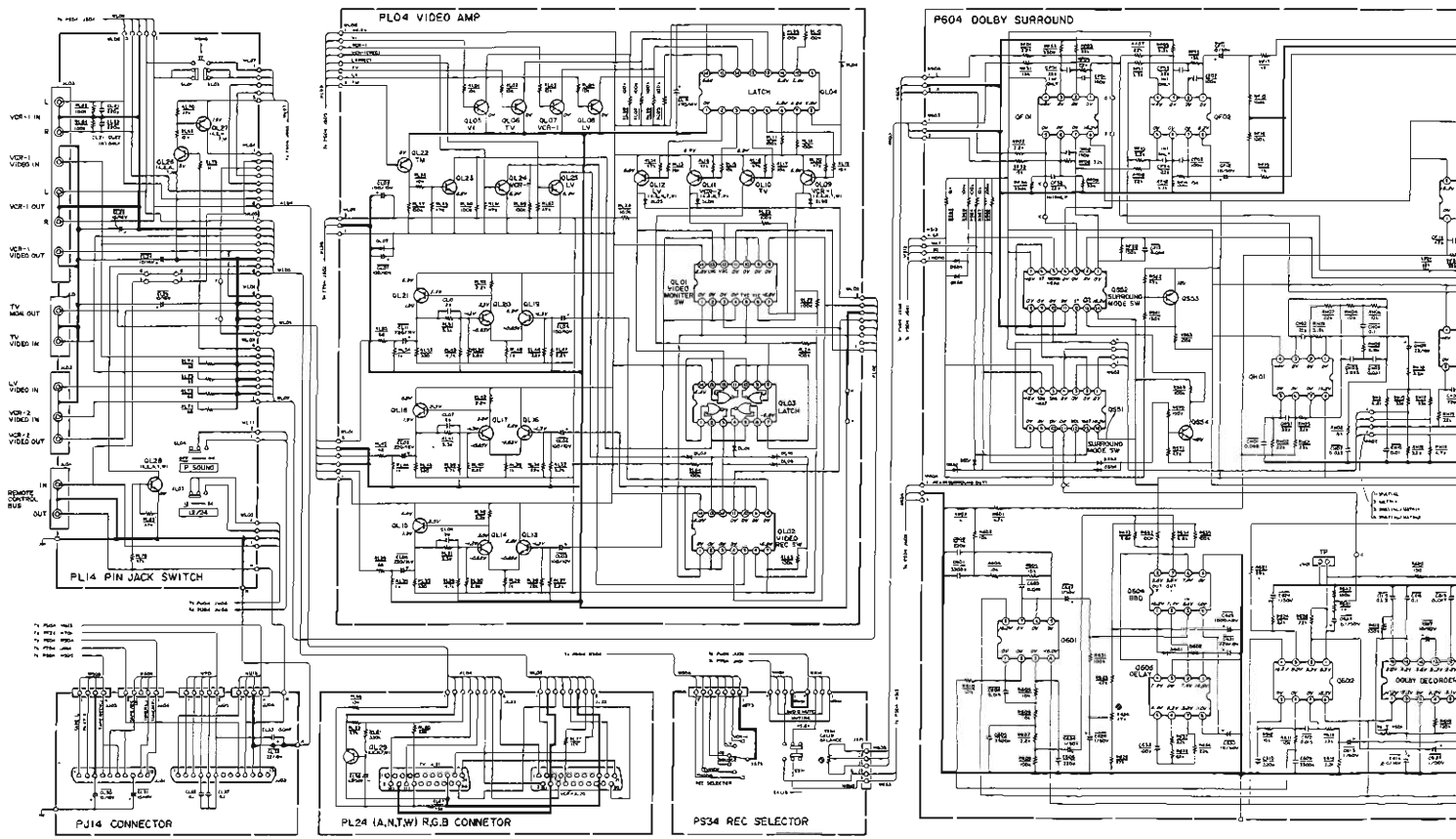

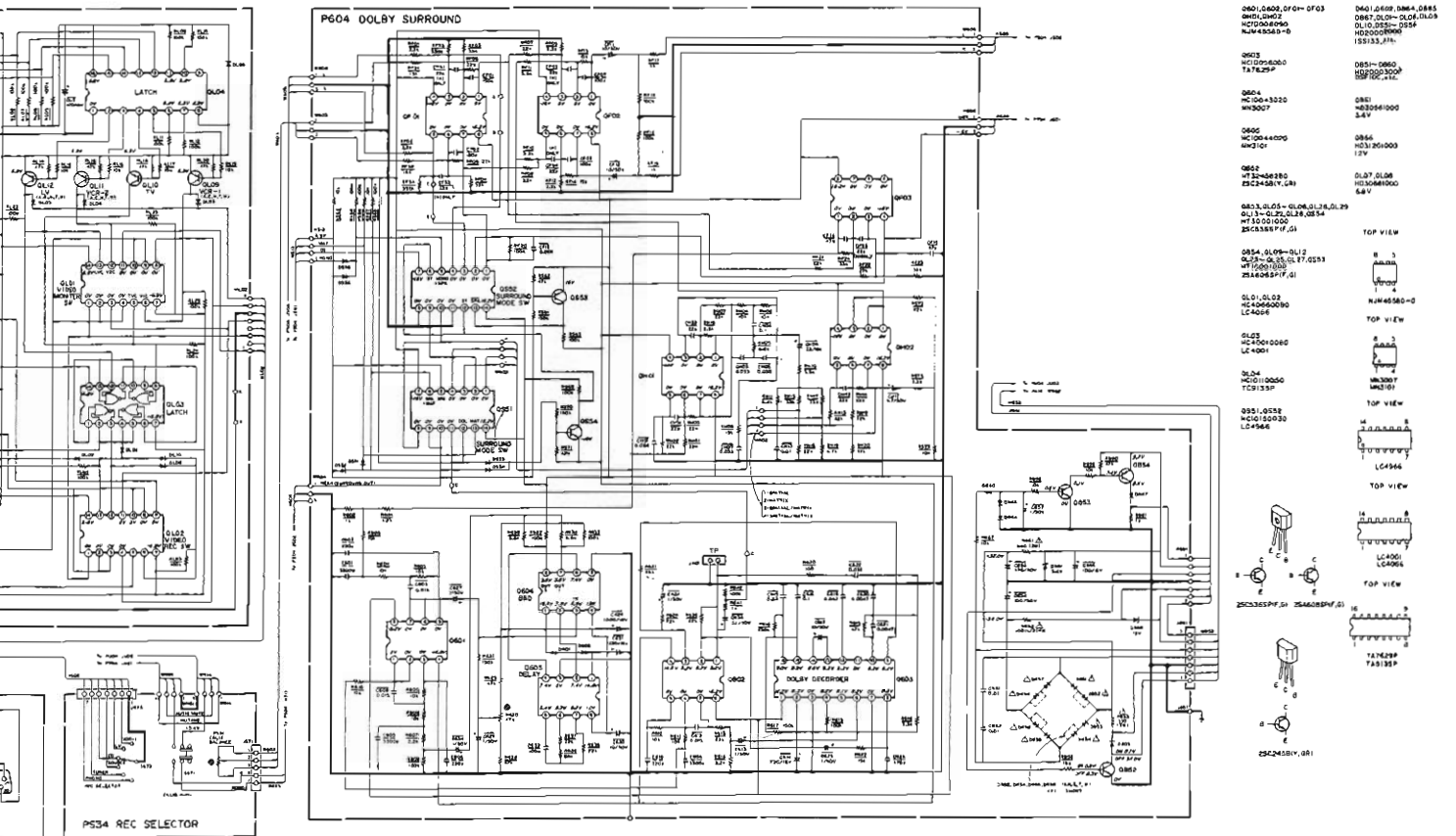

PM-51
SCHEMATIC DIAGRAM OF PM673 (2/4)

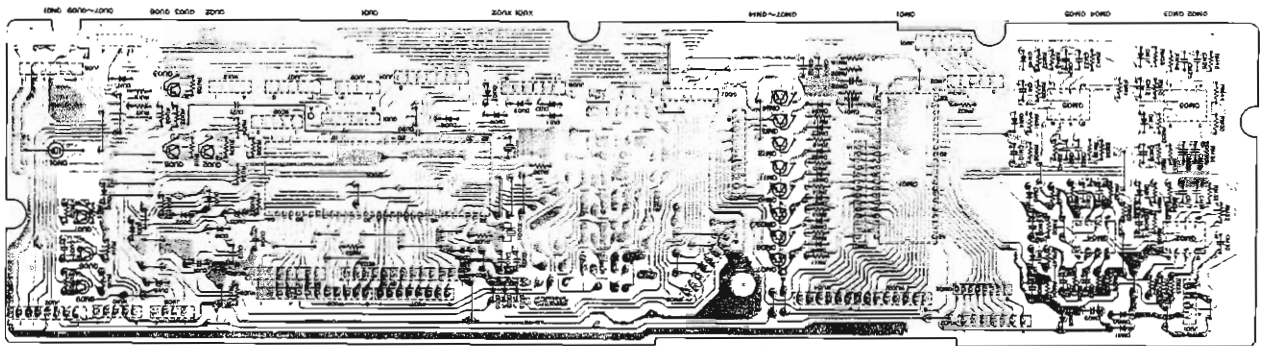

PU04 - μ-COM

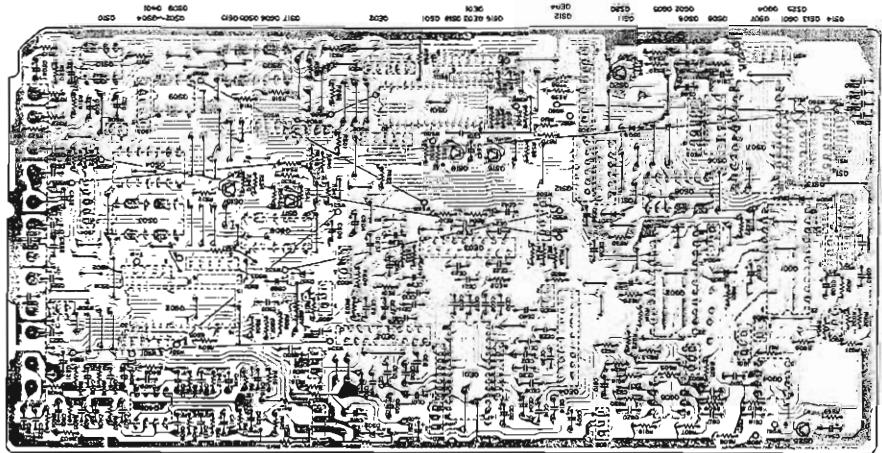

PS04 - SELECTOR

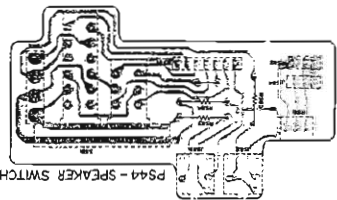

PS44 - SPEAKER SWITCH

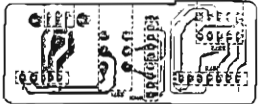

PS34 - REC SELECTOR



PS34-REC SELECTOR

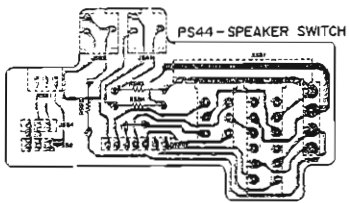
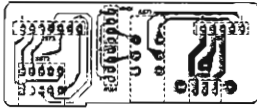

PS44-SPEAKER SWITCH

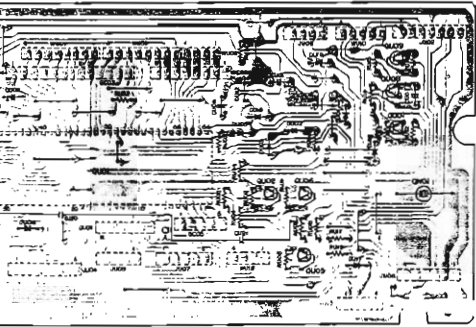

0401 1007-0109 0401 1007-0109 0401

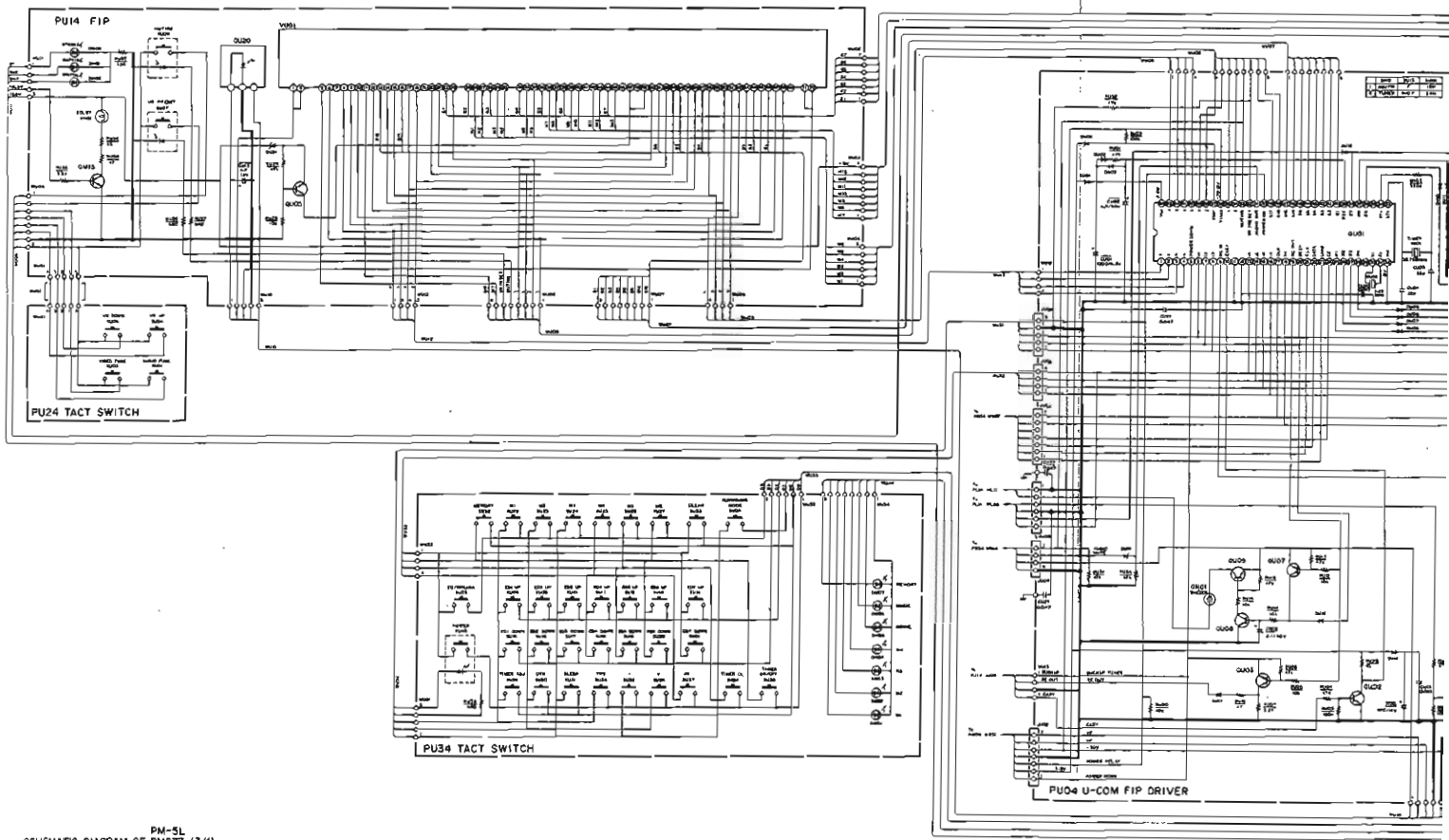

PM-5L
SCHEMATIC DIAGRAM OF PM673 (3/4)

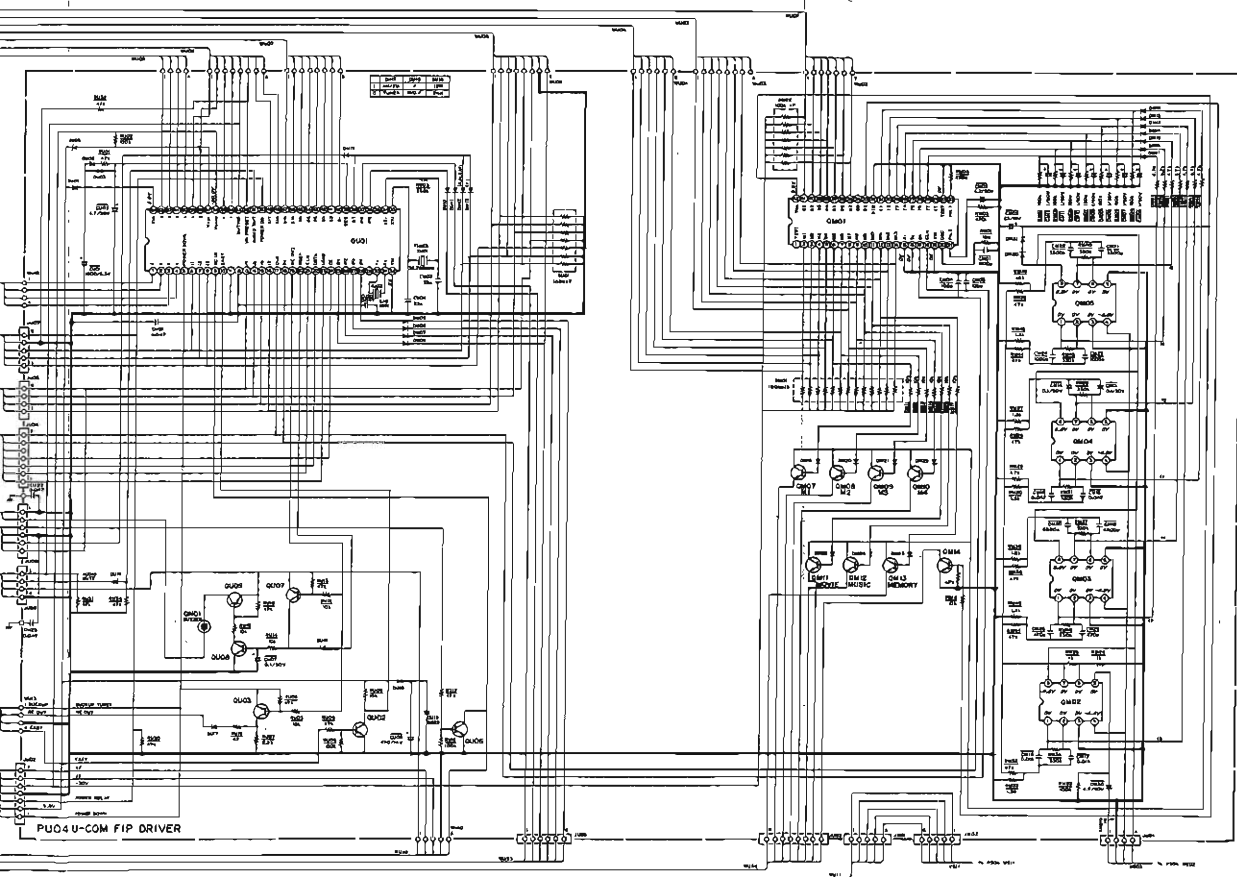

- | | | | | | | |
|------|-----------|---------|------|------------------|------------------------|---|
| Q101 | MS0000250 | LC7565 | Q102 | MS10 | HT0000250 | LT 3088 |
| Q103 | MS0000300 | MS15180 | Q104 | MS17, MS19, MS20 | MS21, MS22, MS23, MS24 | MS25, MS26, MS27, MS28, MS29, MS30, MS31, MS32, MS33, MS34, MS35, MS36, MS37, MS38, MS39, MS40, MS41, MS42, MS43, MS44, MS45, MS46, MS47, MS48, MS49, MS50, MS51, MS52, MS53, MS54, MS55, MS56, MS57, MS58, MS59, MS60, MS61, MS62, MS63, MS64, MS65, MS66, MS67, MS68, MS69, MS70, MS71, MS72, MS73, MS74, MS75, MS76, MS77, MS78, MS79, MS80, MS81, MS82, MS83, MS84, MS85, MS86, MS87, MS88, MS89, MS90, MS91, MS92, MS93, MS94, MS95, MS96, MS97, MS98, MS99, MS100 |
| Q105 | MS0000350 | MS15180 | Q106 | MS10 | HT0000250 | LT 3088 |
| Q107 | MS0000400 | MS15180 | Q108 | MS10 | HT0000250 | LT 3088 |
| Q109 | MS0000450 | MS15180 | Q110 | MS10 | HT0000250 | LT 3088 |
| Q111 | MS0000500 | MS15180 | Q112 | MS10 | HT0000250 | LT 3088 |
| Q113 | MS0000550 | MS15180 | Q114 | MS10 | HT0000250 | LT 3088 |
| Q115 | MS0000600 | MS15180 | Q116 | MS10 | HT0000250 | LT 3088 |
| Q117 | MS0000650 | MS15180 | Q118 | MS10 | HT0000250 | LT 3088 |
| Q119 | MS0000700 | MS15180 | Q120 | MS10 | HT0000250 | LT 3088 |
| Q121 | MS0000750 | MS15180 | Q122 | MS10 | HT0000250 | LT 3088 |
| Q123 | MS0000800 | MS15180 | Q124 | MS10 | HT0000250 | LT 3088 |
| Q125 | MS0000850 | MS15180 | Q126 | MS10 | HT0000250 | LT 3088 |
| Q127 | MS0000900 | MS15180 | Q128 | MS10 | HT0000250 | LT 3088 |
| Q129 | MS0000950 | MS15180 | Q130 | MS10 | HT0000250 | LT 3088 |
| Q131 | MS0001000 | MS15180 | Q132 | MS10 | HT0000250 | LT 3088 |
| Q133 | MS0001050 | MS15180 | Q134 | MS10 | HT0000250 | LT 3088 |
| Q135 | MS0001100 | MS15180 | Q136 | MS10 | HT0000250 | LT 3088 |
| Q137 | MS0001150 | MS15180 | Q138 | MS10 | HT0000250 | LT 3088 |
| Q139 | MS0001200 | MS15180 | Q140 | MS10 | HT0000250 | LT 3088 |
| Q141 | MS0001250 | MS15180 | Q142 | MS10 | HT0000250 | LT 3088 |
| Q143 | MS0001300 | MS15180 | Q144 | MS10 | HT0000250 | LT 3088 |
| Q145 | MS0001350 | MS15180 | Q146 | MS10 | HT0000250 | LT 3088 |
| Q147 | MS0001400 | MS15180 | Q148 | MS10 | HT0000250 | LT 3088 |
| Q149 | MS0001450 | MS15180 | Q150 | MS10 | HT0000250 | LT 3088 |
| Q151 | MS0001500 | MS15180 | Q152 | MS10 | HT0000250 | LT 3088 |
| Q153 | MS0001550 | MS15180 | Q154 | MS10 | HT0000250 | LT 3088 |
| Q155 | MS0001600 | MS15180 | Q156 | MS10 | HT0000250 | LT 3088 |
| Q157 | MS0001650 | MS15180 | Q158 | MS10 | HT0000250 | LT 3088 |
| Q159 | MS0001700 | MS15180 | Q160 | MS10 | HT0000250 | LT 3088 |
| Q161 | MS0001750 | MS15180 | Q162 | MS10 | HT0000250 | LT 3088 |
| Q163 | MS0001800 | MS15180 | Q164 | MS10 | HT0000250 | LT 3088 |
| Q165 | MS0001850 | MS15180 | Q166 | MS10 | HT0000250 | LT 3088 |
| Q167 | MS0001900 | MS15180 | Q168 | MS10 | HT0000250 | LT 3088 |
| Q169 | MS0001950 | MS15180 | Q170 | MS10 | HT0000250 | LT 3088 |
| Q171 | MS0002000 | MS15180 | Q172 | MS10 | HT0000250 | LT 3088 |
| Q173 | MS0002050 | MS15180 | Q174 | MS10 | HT0000250 | LT 3088 |
| Q175 | MS0002100 | MS15180 | Q176 | MS10 | HT0000250 | LT 3088 |
| Q177 | MS0002150 | MS15180 | Q178 | MS10 | HT0000250 | LT 3088 |
| Q179 | MS0002200 | MS15180 | Q180 | MS10 | HT0000250 | LT 3088 |
| Q181 | MS0002250 | MS15180 | Q182 | MS10 | HT0000250 | LT 3088 |
| Q183 | MS0002300 | MS15180 | Q184 | MS10 | HT0000250 | LT 3088 |
| Q185 | MS0002350 | MS15180 | Q186 | MS10 | HT0000250 | LT 3088 |
| Q187 | MS0002400 | MS15180 | Q188 | MS10 | HT0000250 | LT 3088 |
| Q189 | MS0002450 | MS15180 | Q190 | MS10 | HT0000250 | LT 3088 |
| Q191 | MS0002500 | MS15180 | Q192 | MS10 | HT0000250 | LT 3088 |
| Q193 | MS0002550 | MS15180 | Q194 | MS10 | HT0000250 | LT 3088 |
| Q195 | MS0002600 | MS15180 | Q196 | MS10 | HT0000250 | LT 3088 |
| Q197 | MS0002650 | MS15180 | Q198 | MS10 | HT0000250 | LT 3088 |
| Q199 | MS0002700 | MS15180 | Q200 | MS10 | HT0000250 | LT 3088 |

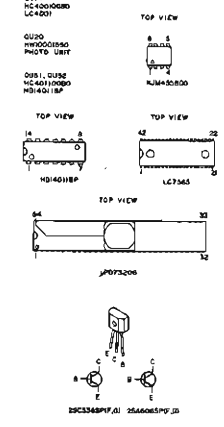

PU04 U-COM FIP DRIVER

PU24 - TACT SWITCH

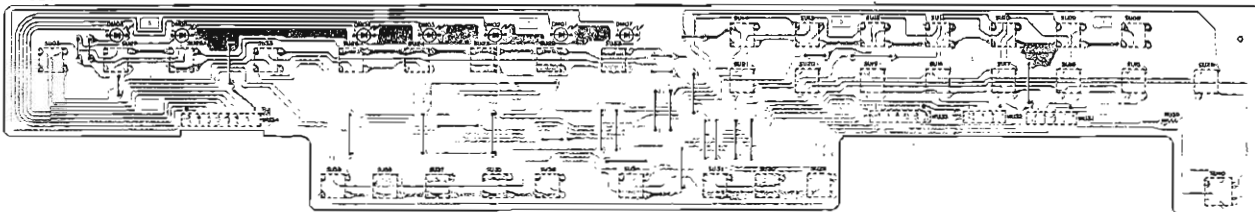

PU14 - FIP

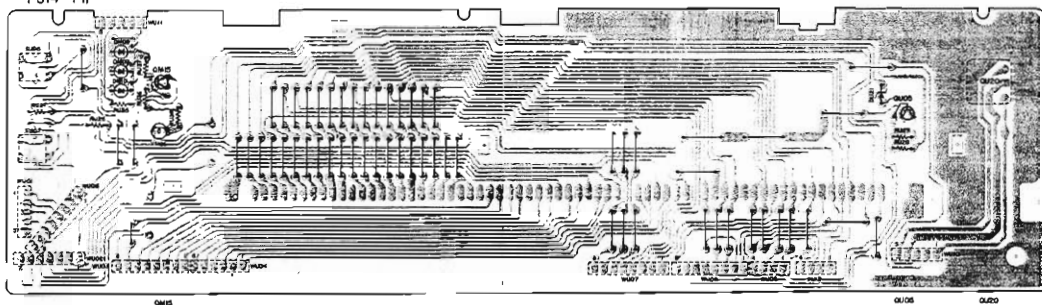

P754 - POWER AMP / SUPPLY

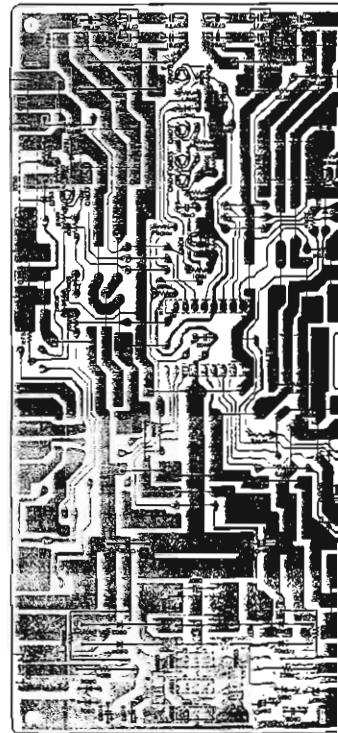

P604 - DOLBY SURROUND

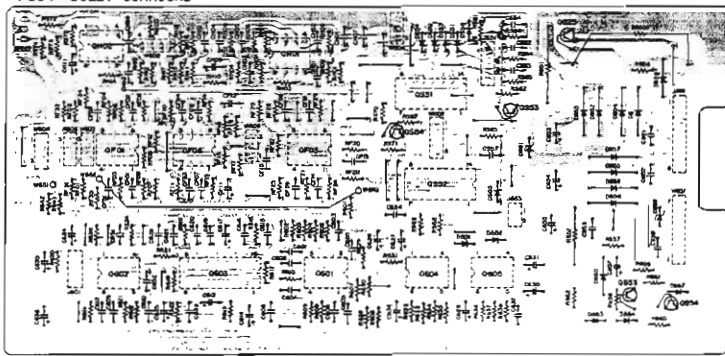

FOREIGNER 3 (PS94)

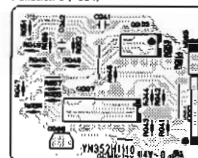

P714 - TR (L)



F724 - TR (R)



P734 - TR DOLBY



P801 - REG.



0402 0F04 0602 0F06 0603 0401 0F03 0601 0504 0.050 0604 0502 0605 0603 0605 0604

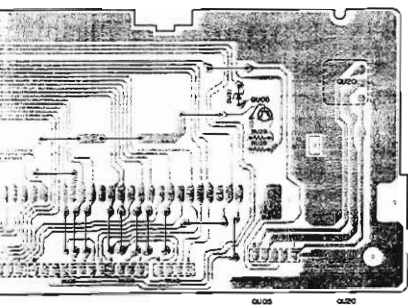
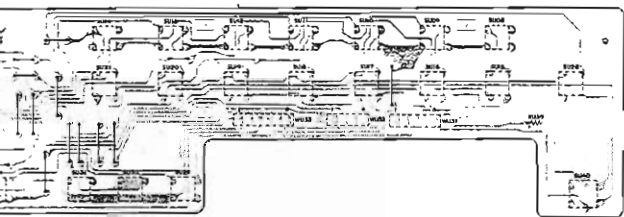

P754 - POWER AMP/SUPPLY

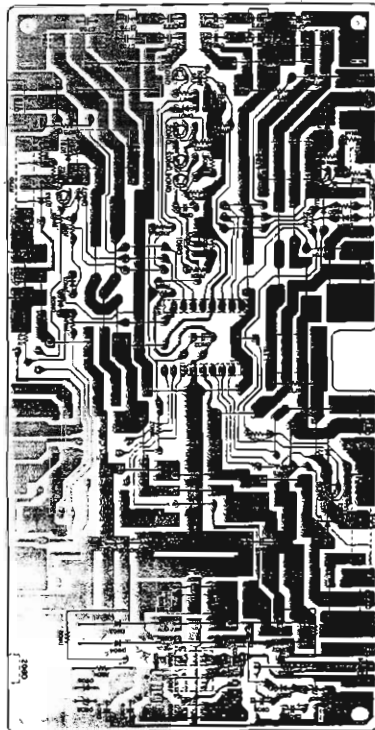

FUNCTION J (P594)

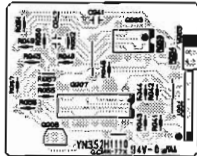

P714 - TR(L)



P724 - TR(R)



P734 - TR DOLBY



P801 - REG.



0793 0794 0800 0801 0802 0803 0804 0805 0806 0807 0808 0809 0810 0811 0812 0813 0814 0815 0816 0817 0818 0819 0820 0821 0822 0823 0824 0825 0826 0827 0828 0829 0830 0831 0832 0833 0834 0835 0836 0837 0838 0839 0840 0841 0842 0843 0844 0845 0846 0847 0848 0849 0850 0851 0852 0853 0854 0855 0856 0857 0858 0859 0860 0861 0862 0863 0864 0865 0866 0867 0868 0869 0870 0871 0872 0873 0874 0875 0876 0877 0878 0879 0880 0881 0882 0883 0884 0885 0886 0887 0888 0889 0890 0891 0892 0893 0894 0895 0896 0897 0898 0899 0900

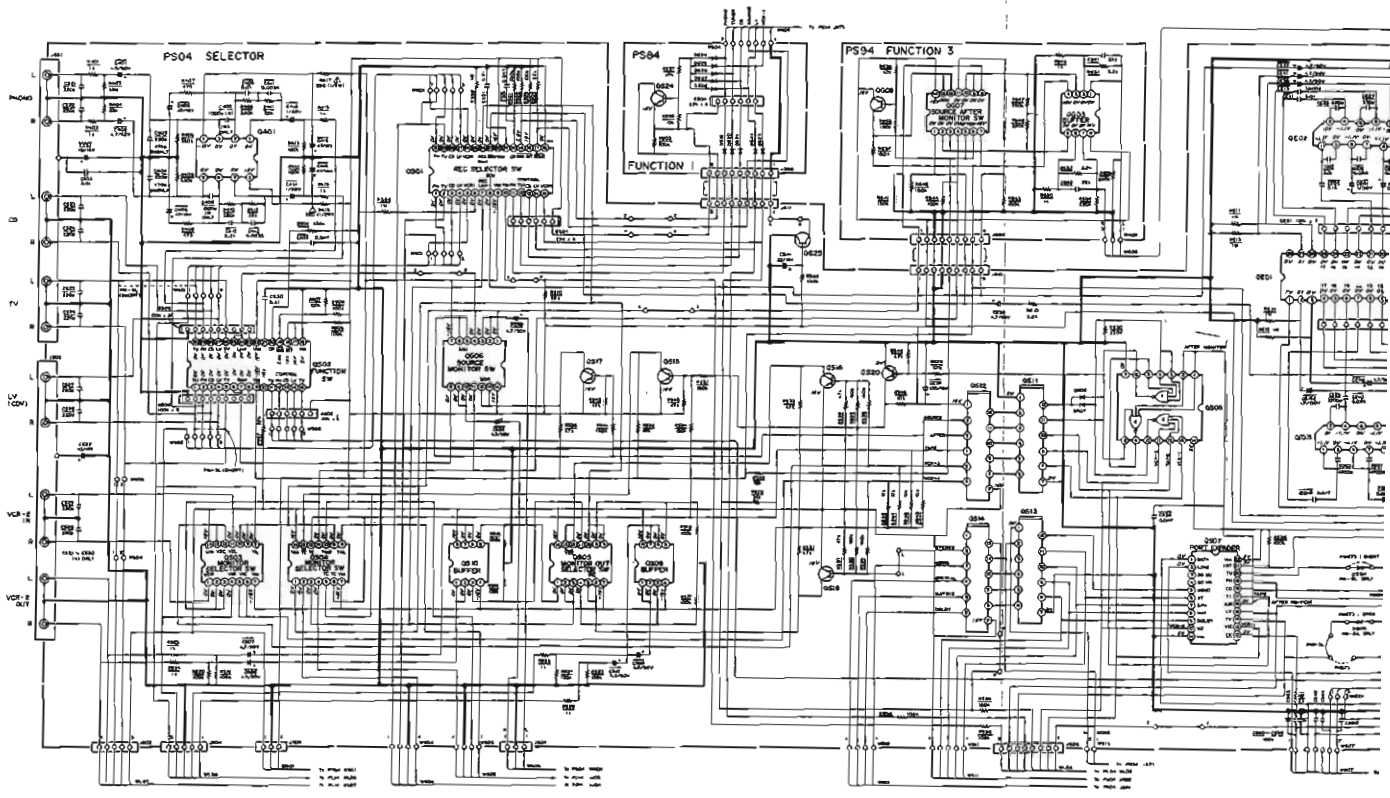

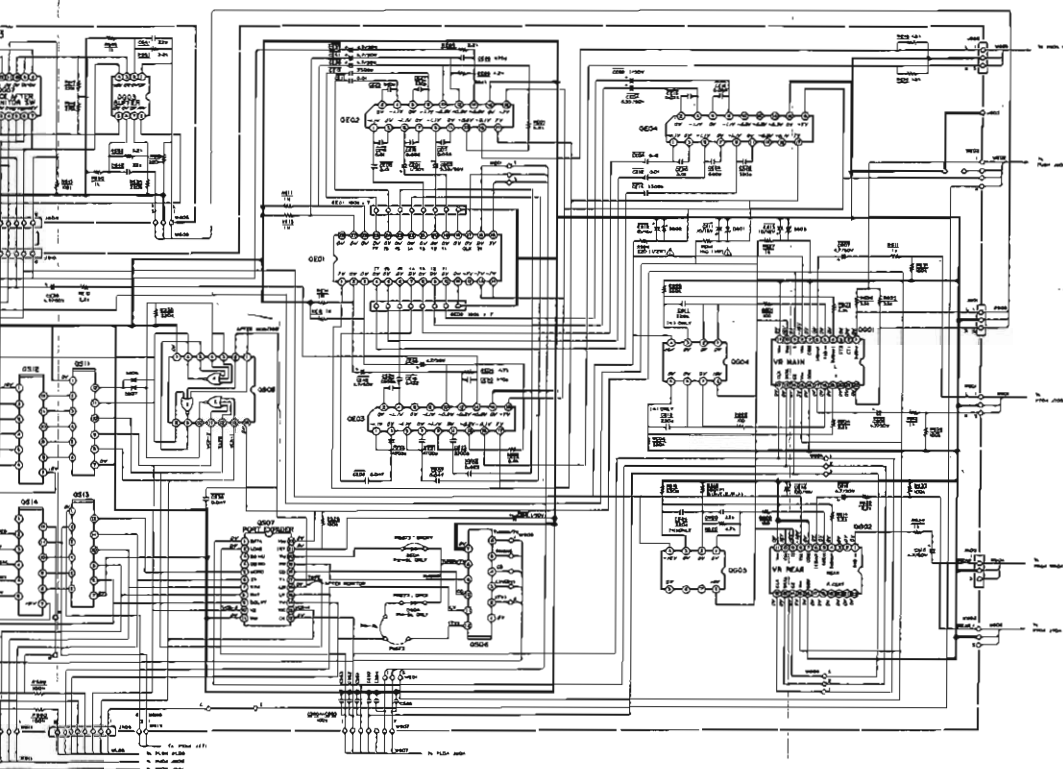

- 0E01 0E02
HC0010050
L7152
- 0E03-0E04
HC0004210
BA3812C
- 0E05-0E06
HC0011035
L7153
- 0E07-0E08, 0E09
0E10, 0E11
HC0000050
N18M4589-0
- 0E09-0E07
0E03-0E05, 0E09
0E10, 0E11
HC0000050
N18M4589-0
- 0E01, 0E02
HC0010050
L7152
- 0E06, 0E11, 0E13
HC0041310
D78114E
- 0E07
HC0000050
N18M4589-0
- 0E08
HC0005090
J140050C
- 0E12, 0E14
HC0008010
D78114E
- 0E03, 0E05-0E09
0E10
N18M4589-0
- 0E20, 0E25
HC0010050
L7152
- 0E01, 0E02
HC0010050
L7152
- 0E03
HC0010050
L7152
- 0E04-0E07
0E08-0E09
0E10-0E11
HC0000050
N18M4589-0
- 0E01, 0E02
HC0010050
L7152
- 0E06, 0E11, 0E13
HC0041310
D78114E
- 0E07
HC0000050
N18M4589-0
- 0E08
HC0005090
J140050C
- 0E12, 0E14
HC0008010
D78114E
- 0E03, 0E05-0E09
0E10
N18M4589-0
- 0E20, 0E25
HC0010050
L7152

SCHEMATIC DIAGRAM OF PM673 / PM-5L (1/4)

PLO4-VIDEO AMP

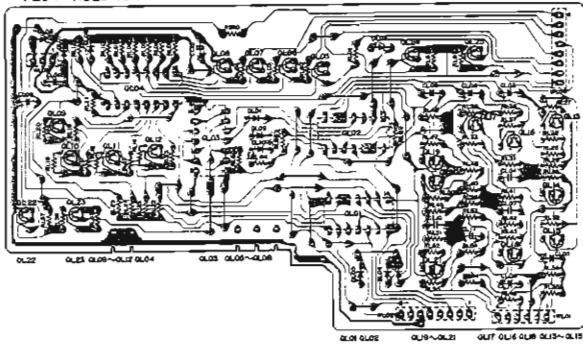

PS84 - FUNCTION

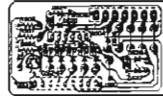

PT24 - TRANSF.



PT04-SPEAKER TERMINAL

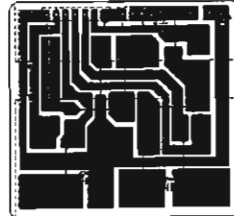

PU34 - TACT SWITCH

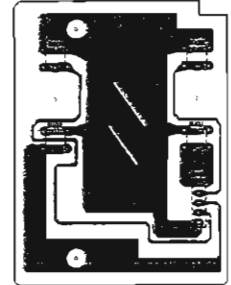

PJ14 - CONECTOR

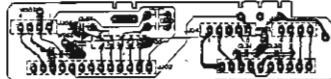

PL14 - PIN JACK SWITCH

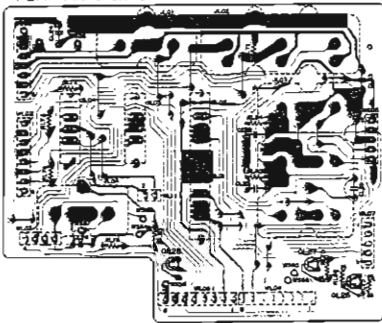

PA14 - RELAY (E) VERSION

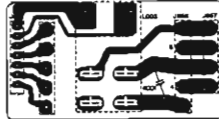

PA14 - RELAY (A,N,T,W) VERSION

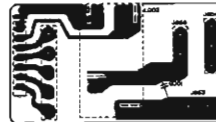

FL24 - R.G.B. CONECTOR

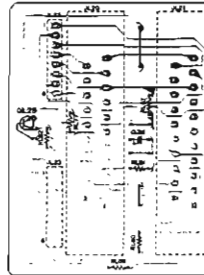

P704 - POWER AMP DRIVER

