

SERVICE  
MANUAL

PM683

4822 725 50877

**marantz®**

model PM683

*Stereo Amplifier*

## MARANTZ DESIGN AND SERVICE

Using superior design and selected high grade components, MARANTZ company has created the ultimate in stereo sound.

Only **original MARANTZ parts** can insure that your MARANTZ product will continue to perform to the specifications for which it is famous.

Parts for your MARANTZ equipment are generally available to our National Marantz Subsidiary or Agent.

### ORDERING PARTS:

Parts can be ordered either by mail or by telex. In both cases, correct part number has to be specified. The following information must be supplied to eliminate delays in processing your order:

1. Complete address
2. Complete part numbers and quantities required
3. Description of parts
4. Model number for which part is required
5. Way of shipment
6. Signature: any order form or telex must be signed otherwise such part order will be considered as null and void.

### PARTS ORDERING

Parts may be ordered at the following addresses:

<b>AUSTRIA</b> HORNYPHON Vertriebsgesellschaft GmbH Wienerbergstrasse 1 A 1101 Wien Austria Telex: 132.332	<b>FINLAND</b> MARANTZ DIVISION OF OY PHILIPS Ab Kaivokatu 8 00100 Helsinki Finland Telex: 124811	<b>GREAT BRITAIN</b> MARANTZ AUDIO U.K. Ltd Unit 15/16 Saxon Way Industrial Estate Moor Lane Harmondsworth UB7 0LW Great Britain Telex: 935196	<b>SAUDI ARABIA</b> AL ALAMIAH ELECTRONICS P.O.Box 5954 University Street Riyadh 11432 Saudi Arabia Telex: 401530	<b>SWITZERLAND</b> DYNAVOX ELECTRONICS Route de Villars 105 1701 Fribourg Switzerland Telex: 942377
<b>BELGIUM</b> SVD DIVISION MARANTZ Industrialaan 1 1720 Groot-Bijgaarden Belgium Telex: 24466	<b>FRANCE</b> MARANTZ FRANCE 4 Rue Bernard Palissy 92600 Asnières France Telex: 611651	<b>GREECE</b> SHERTON ELECTRONICS S.A. P.O.Box 21025 Hippocrates Street 188 Athens 11471 Greece Telex: 216.795	<b>SOUTH AFRICA</b> MARANTZ DIVISION OF PHILIPS S.A. Main Road Martindale P.O. Box. 58088 Newville 21114 South Africa	<b>TURKEY</b> DOGRUOL Ltd. I.M.C. 6 Blok N°6310 Unkapani Istanbul Turkey Telex: 22085
<b>CHILE</b> MARANTZ DIVISION OF PHILIPS S.A. AV. Santa Maria, 0760 Casilla 2687 Santiago Telex: 240.239	<b>GERMANY</b> MARANTZ GERMANY GmbH Max-Planck-Strasse 22 6072 Dreieich 1 Germany Telex: 529821	<b>JAPAN</b> MARANTZ JAPAN, Inc. 35-1, 7-chome, Sagamiono Sagamihara-shi, Kanagawa Japan	<b>SPAIN</b> PHONO S.A. Ignacio Iglesias 10 Badalona (Barcelona) Spain Telex: 59355	<b>MALTA</b> CACHIA & GALEA Republic Street, 68D Valetta Telex: 1682
<b>DENMARK</b> MARANTZ DIVISION OF PHILIPS SERVICE A/S Prags Boulevard 80 Postbox 1919 DK-2300 København S Denmark Telex: 31201	<b>THE NETHERLANDS</b> Elpro Marantz Wint Hontlaan 28 3526 KV Utrecht The Netherlands Telex: 4748	<b>KUWAIT</b> AL ALAMIAH ELECTRONICS Ussama Building Fahd al Saleem Street P.O.Box 23781 Safat-Kuwait Telex: 22694	<b>SWEDEN</b> MARANTZ DIVISION OF PHILIPS Försäljning AB Tegeluddsvägen 1 S-115 84 Stockholm Sweden Telex: 14060	<b>PORTUGAL</b> MARANTZ Divisao philips S.A. service Outurela-carnaxide 2795 Linda-A-VELHA Telex: 43906
	<b>NORWAY</b> MARANTZ DIVISION OF PHILIPS A/S Sandstuveien 40 0680 Oslo 6 Norway Telex: 72640	<b>ITALY</b> MARANTZ ITALIANA S.P.A. Via Chiese, 74 20126 Milano Italy		

All of the above locations are fully equipped to take care of your total service needs. Because various countries have differing configuration requirements, it is necessary that you contact the service facility in your particular country. In the event that there is no service location listed for your country, please, contact the nearest facility for the necessary assistance.

In case of difficulties, do not hesitate to contact the Technical Department at abovementioned address.

## 1. TEST EQUIPMENT REQUIRED FOR SERVICING

This table lists the test equipment required for servicing the Model PM683 Stereo Amplifier.

Item	Use
Distortion Analyzer	Distortion measurements
Audio Oscillator	Sinewave and squarewave signal source
ACVTVM	Voltage measurements (AC)
Oscilloscope	Waveform analysis and trouble shooting and ASO alignment
Circuit Tester	Trouble shooting
DCVTVM	Voltage measurements (DC)
AC Wattmeter	Monitors primary power to amplifier
Line Voltmeter	Monitors potential of primary power to amplifier
Variable Autotransformer (0 to 140V AC, 10A)	Adjust level of primery power to amplifier
Shorting Plug	Shorts amplifier input to eliminate noise pickup

## 2. P.W. BOARDS

As can be seen from the circuit diagram the chassis of Model PM683 consists of the following units. Each unit mounted on a printed circuit board is described within the square enclosed by a bold dotted line on the circuit diagram.

1. Relay ..... mounted on P.W. Board PA14
2. Connector ..... mounted on P.W. Board PJ14
3. Video Amp ..... mounted on P.W. Board PL04
4. Pin Jack/Switch ..... mounted on P.W. Board PL14
5. R.G.B. Connector ..... mounted on P.W. Board PL24
6. Selector ..... mounted on P.W. Board PS04
7. REC Selector ..... mounted on P.W. Board PS34
8. Speaker Switch ..... mounted on P.W. Board PS44
9. Function-1 ..... mounted on P.W. Board PS84
10. Speaker Terminal ..... mounted on P.W. Board PT04
11. U-COM FL Driver ..... mounted on P.W. Board PU04
12. F.I.P. Circuit Board ... mounted on P.W. Board PU14
13. Tact Switch ..... mounted on P.W. Board PU24
14. Tact Switch ..... mounted on P.W. Board PU34
15. Dolby Sorround ..... mounted on P.W. Board P604
16. Power Amp Driver .... mounted on P.W. Board P704
17. Transistor (DOLBY) ... mounted on P.W. Board P714
18. Transistor (DOLBY) ... mounted on P.W. Board P724
19. Transistor (DOLBY) ... mounted on P.W. Board P734
20. Power Amp/Supply ... mounted on P.W. Board P754
21. Regulator ..... mounted on P.W. Board P801
22. Regulator ..... mounted on P.W. Board P802

## 3. ADJUSTMENT PROCEDURES

### • Adjustment of Main Amp Idling Current

Connect a digital voltmeter to the R755, R756, and R776 emitter resistor adjustment terminals, turn the power on, then adjust variable resistors R711, R712, and R731 when the power becomes stable so that the reading on the voltmeter is between 1 mV and 1.5 mV.

### • Adjustment of Dolby Surround Output Distortion

Input 1 kHz to the L or R input terminals, set the mode switch to Dolby Surround, increase the input for a voltage of 1.6 V at the test point (J601), then adjust variable resistor R630 so that the distortion is minimum.

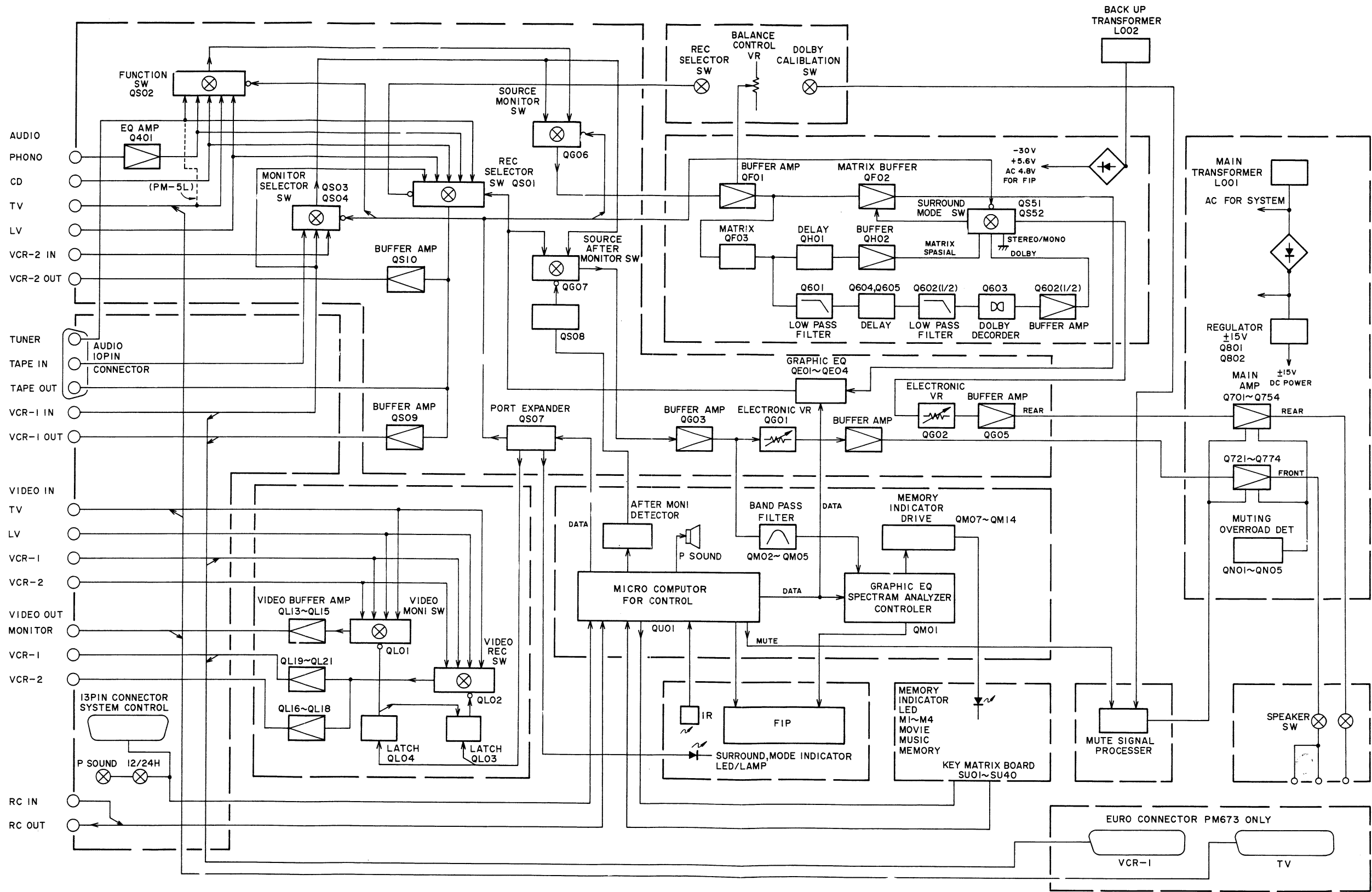

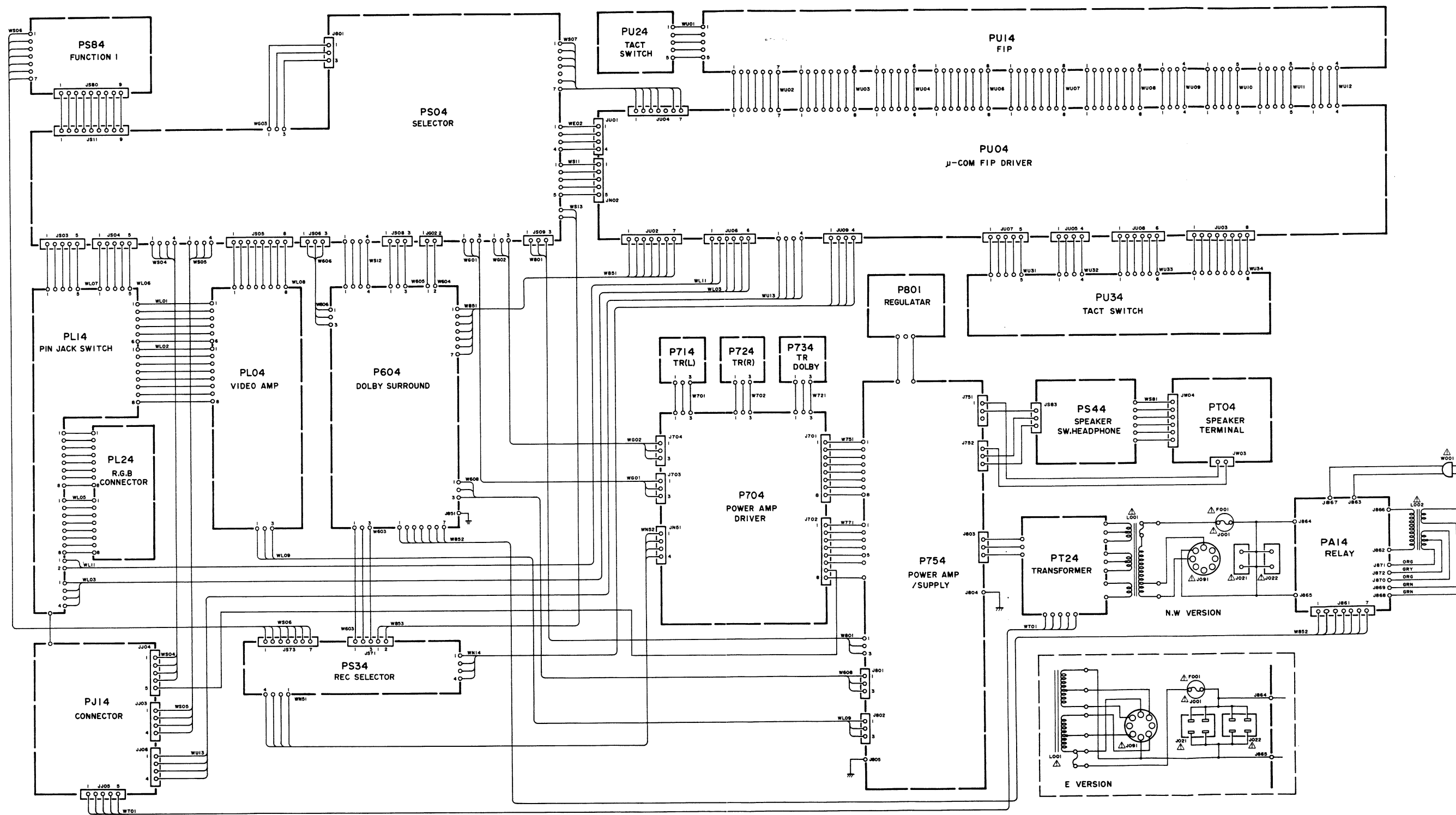



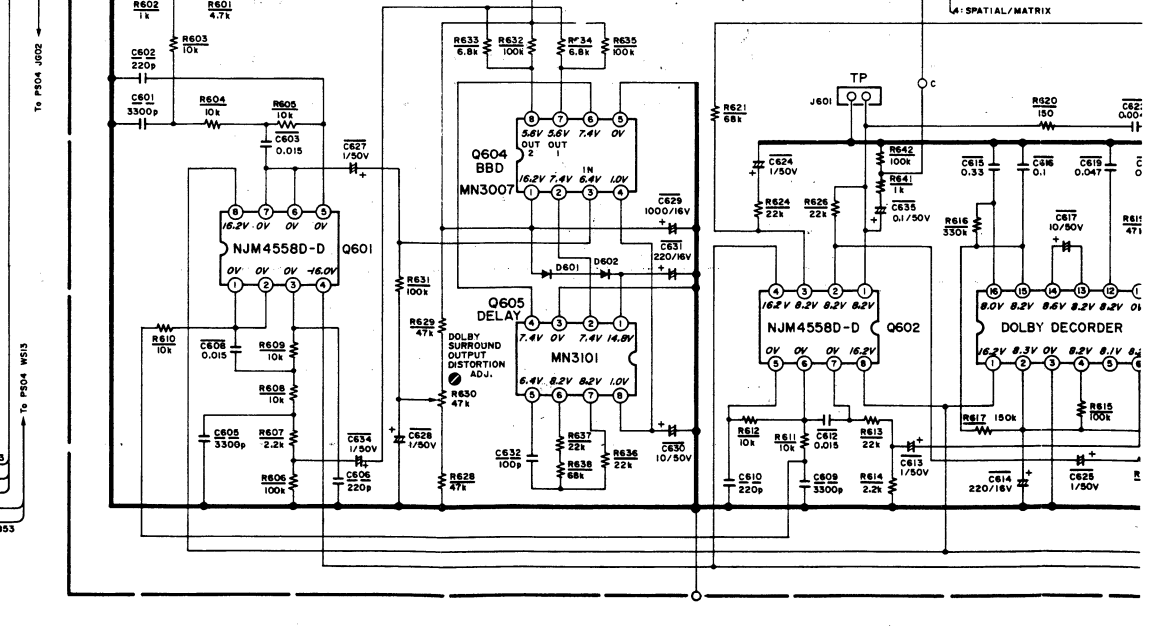
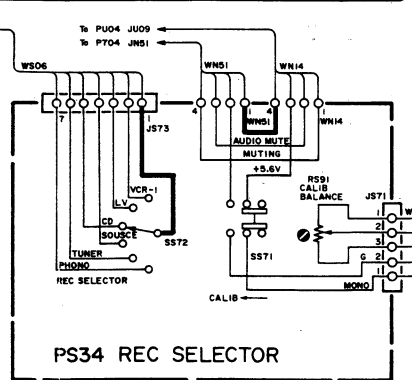
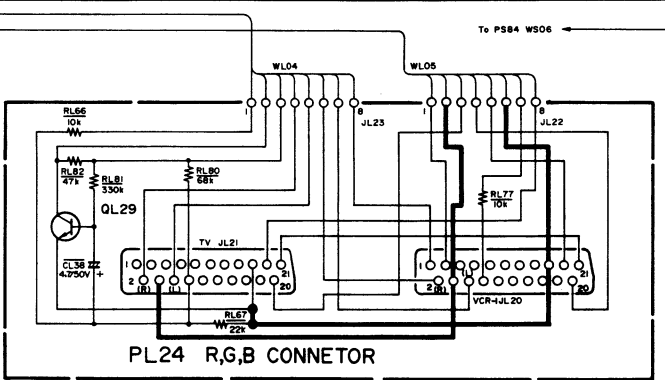
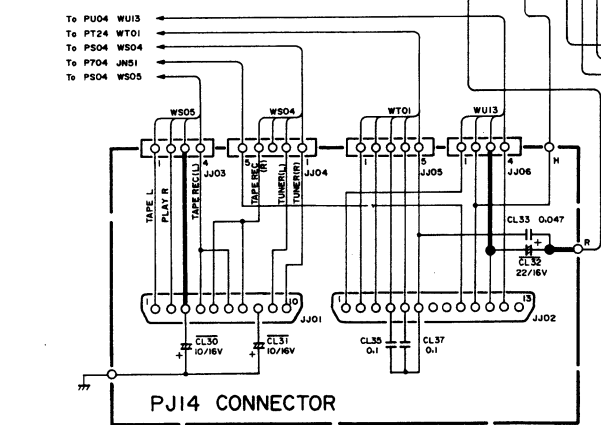
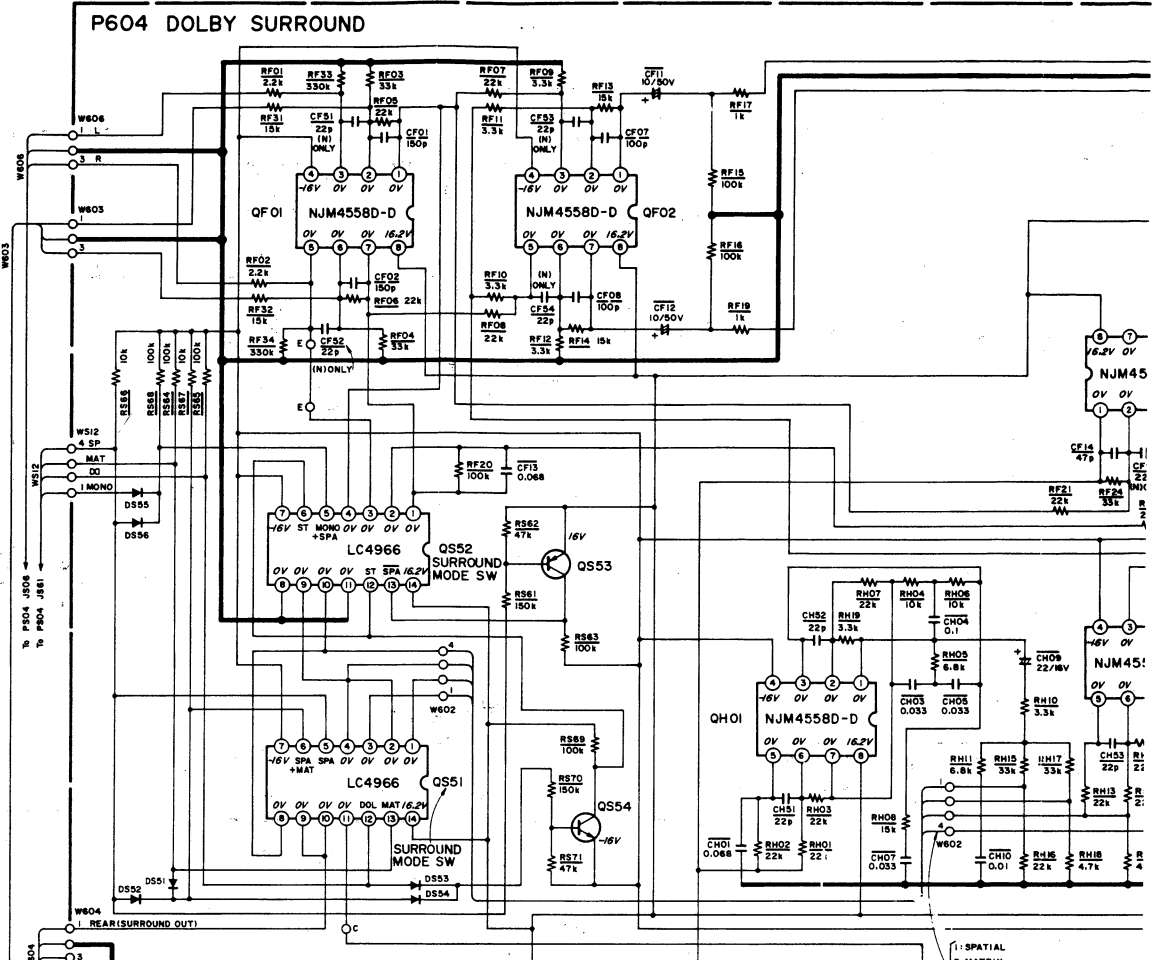
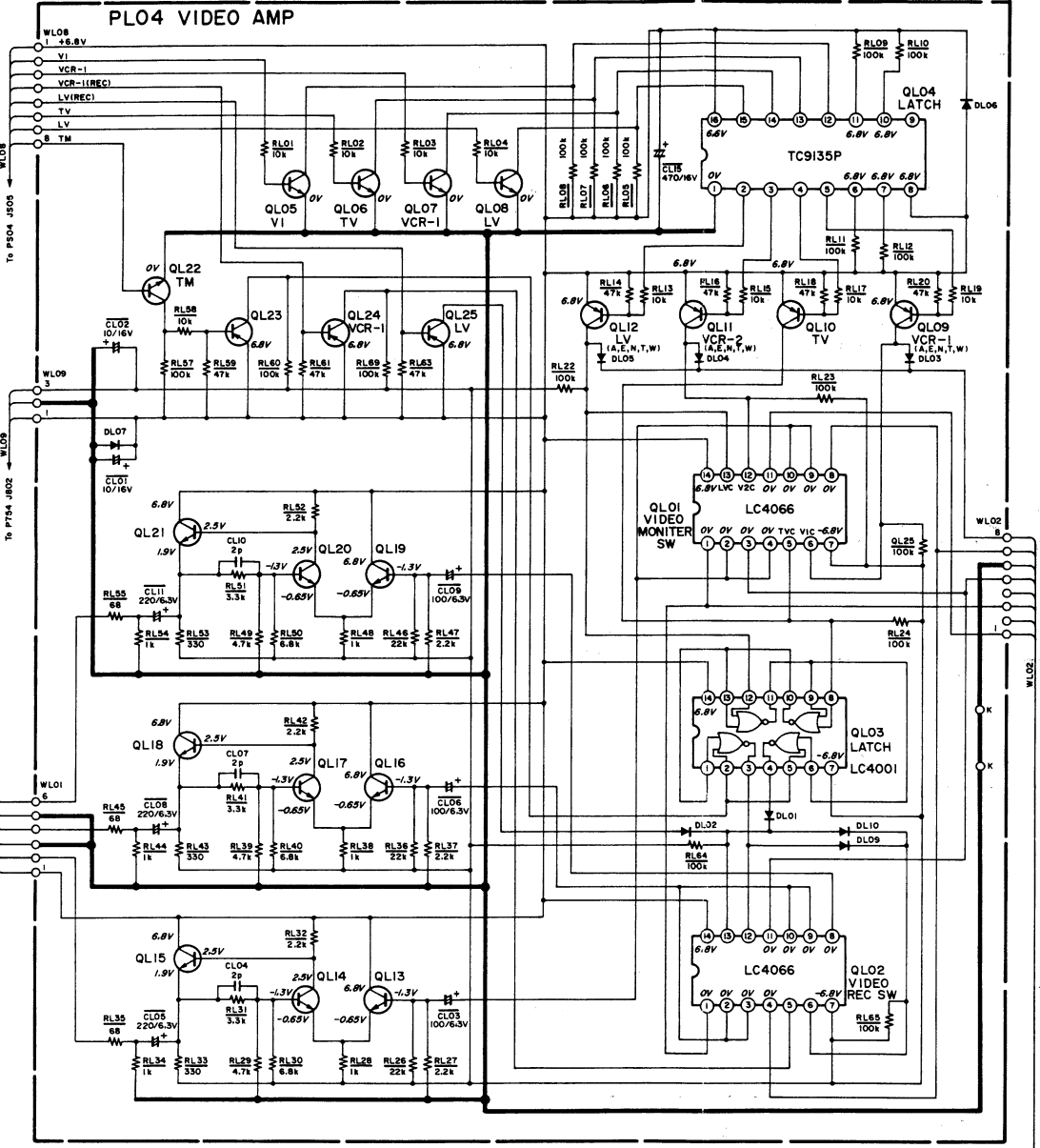
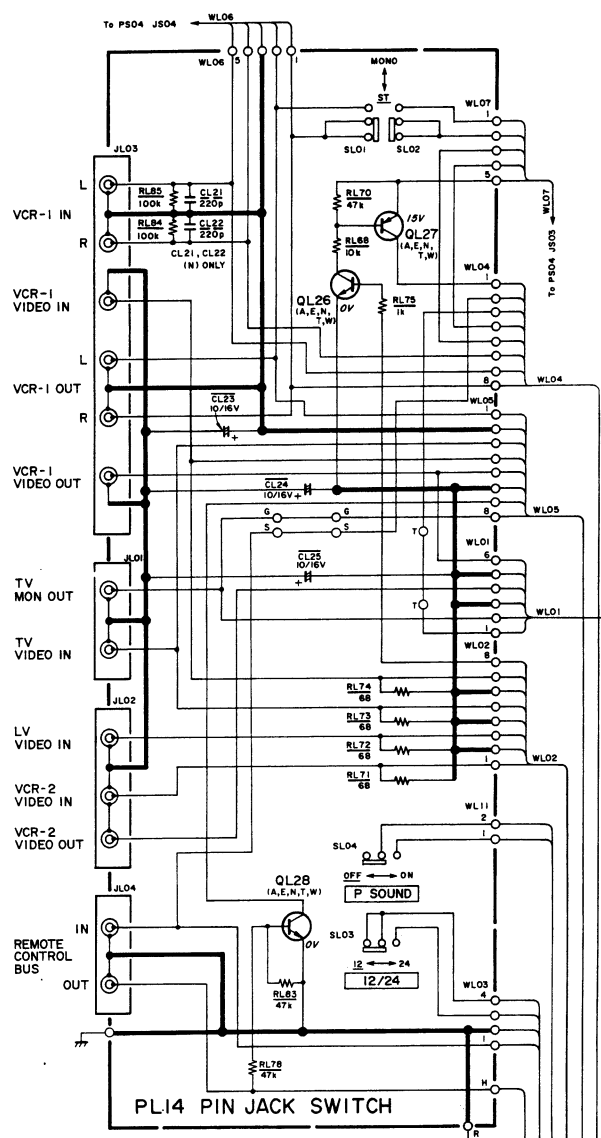

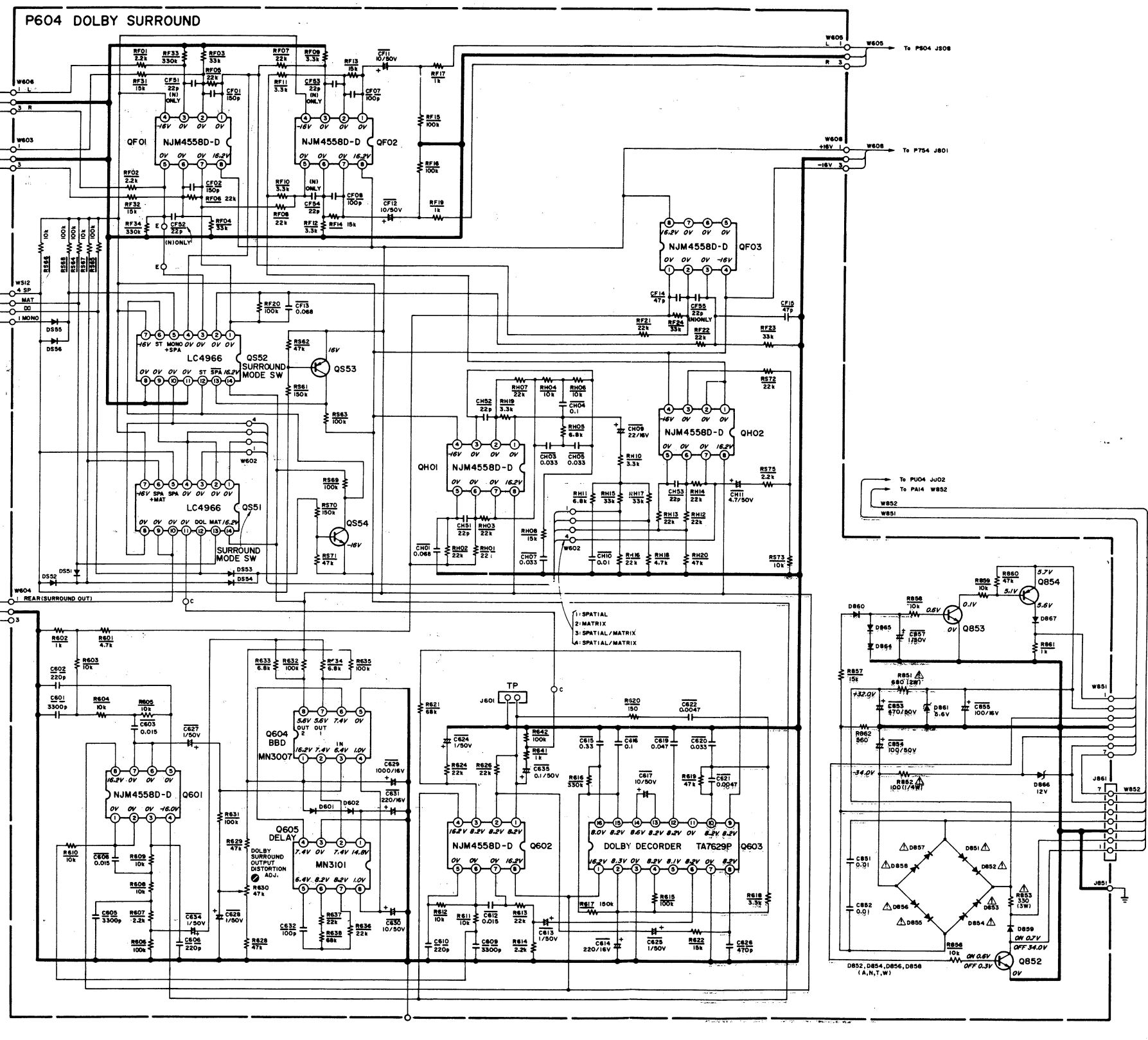
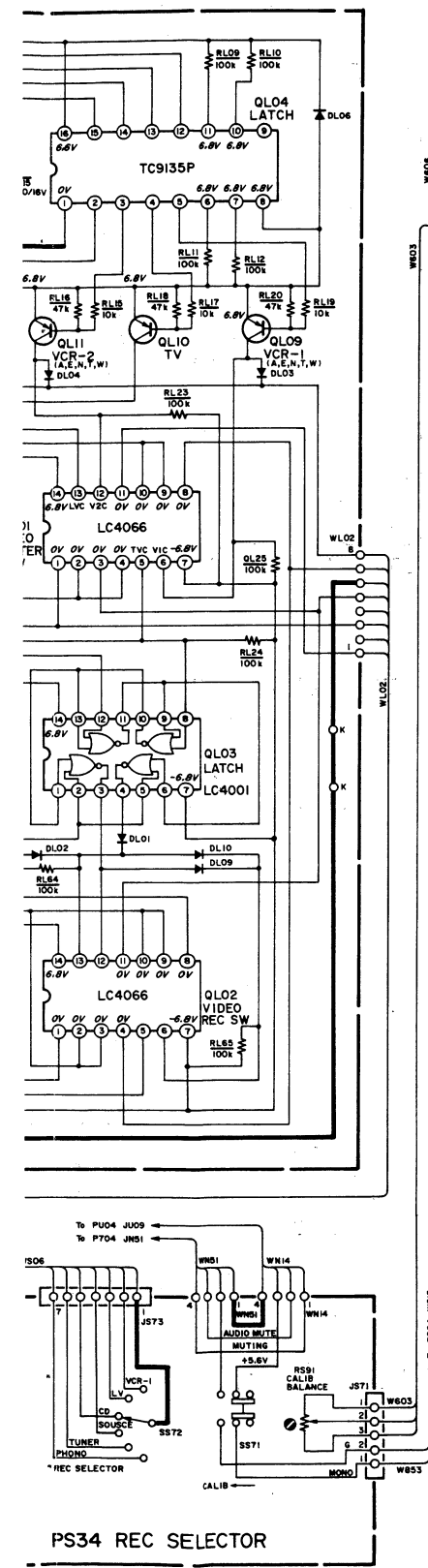

- |                             |                        |
|-----------------------------|------------------------|
| Q601, Q602, QF01~QF03       | D601, D602, D864, D865 |
| QH01, QH02                  | D867, DL01~DL06, DL09  |
| HC10008090                  | DL10, DS51~DS56        |
| NJM4558D-D                  | HD20002000             |
|                             | ISS133, etc.           |
| Q603                        | D851~D860              |
| HC10058050                  | HD20003000             |
| TA7629P                     | DSF10C, etc.           |
| Q604                        | D861                   |
| HC10043020                  | HD30561000             |
| MN3007                      | 5.6V                   |
| Q605                        | D866                   |
| HC10044020                  | HD31201000             |
| MN3101                      | 12V                    |
| Q852                        | DL07, DL08             |
| HT32458280                  | HD30681000             |
| 2SC2458(Y,GR)               | 6.8V                   |
| Q853, QL05~QL08, QL28, QL29 |                        |
| QL13~QL22, QL26, QS54       |                        |
| HT30001000                  |                        |
| 2SC536SP(F,G)               | TOP VIEW               |
| Q854, QL09~QL12             |                        |
| QL23~QL25, QL27, QS53       |                        |
| HT10001000                  |                        |
| 2SA608SP(F,G)               | 8 5                    |
|                             | 1 4                    |
| QL01, QL02                  | NJM4558D-D             |
| HC40010080                  | TOP VIEW               |
| LC4066                      | 8 5                    |
|                             | 1 4                    |
| QL03                        | LC4001                 |
| HC40010080                  | TOP VIEW               |
| LC4001                      | 8 5                    |
|                             | 1 4                    |
| QL04                        | MN3007                 |
| HC10110050                  | MN3101                 |
| TC9135P                     | TOP VIEW               |
| QS51, QS52                  | 14 8                   |
| HC10150030                  | 1 7                    |
| LC4966                      | LC4966                 |
|                             | TOP VIEW               |
|                             | 14 8                   |
|                             | 1 7                    |
|                             | LC4001                 |
|                             | LC4066                 |
|                             | TOP VIEW               |
|                             | 16 9                   |
|                             | 1 8                    |
|                             | TA7629P                |
|                             | TA9135P                |
|                             | TOP VIEW               |
|                             | 16 9                   |
|                             | 1 8                    |
|                             | 2SC2458(Y,GR)          |



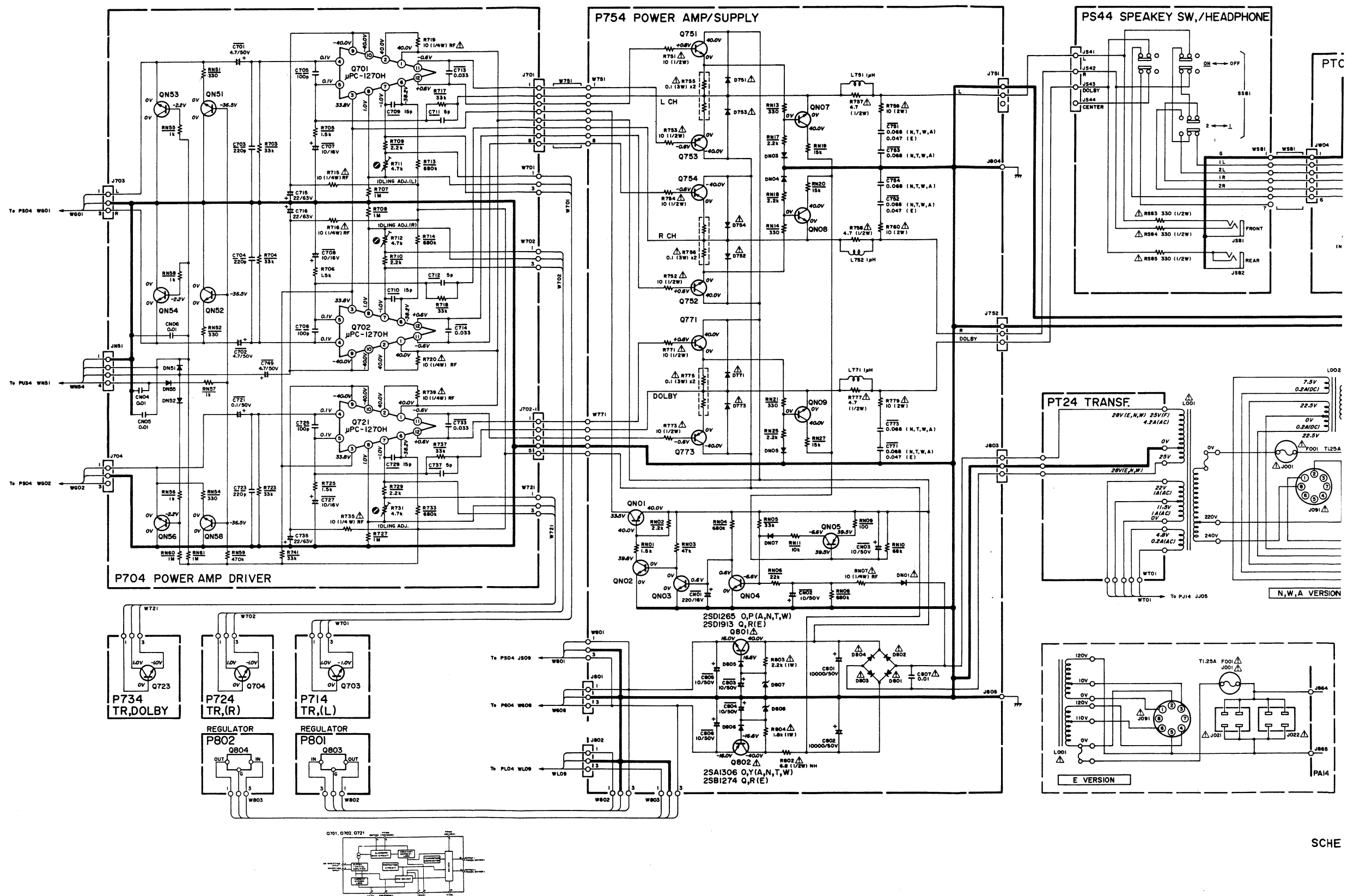

SCHE

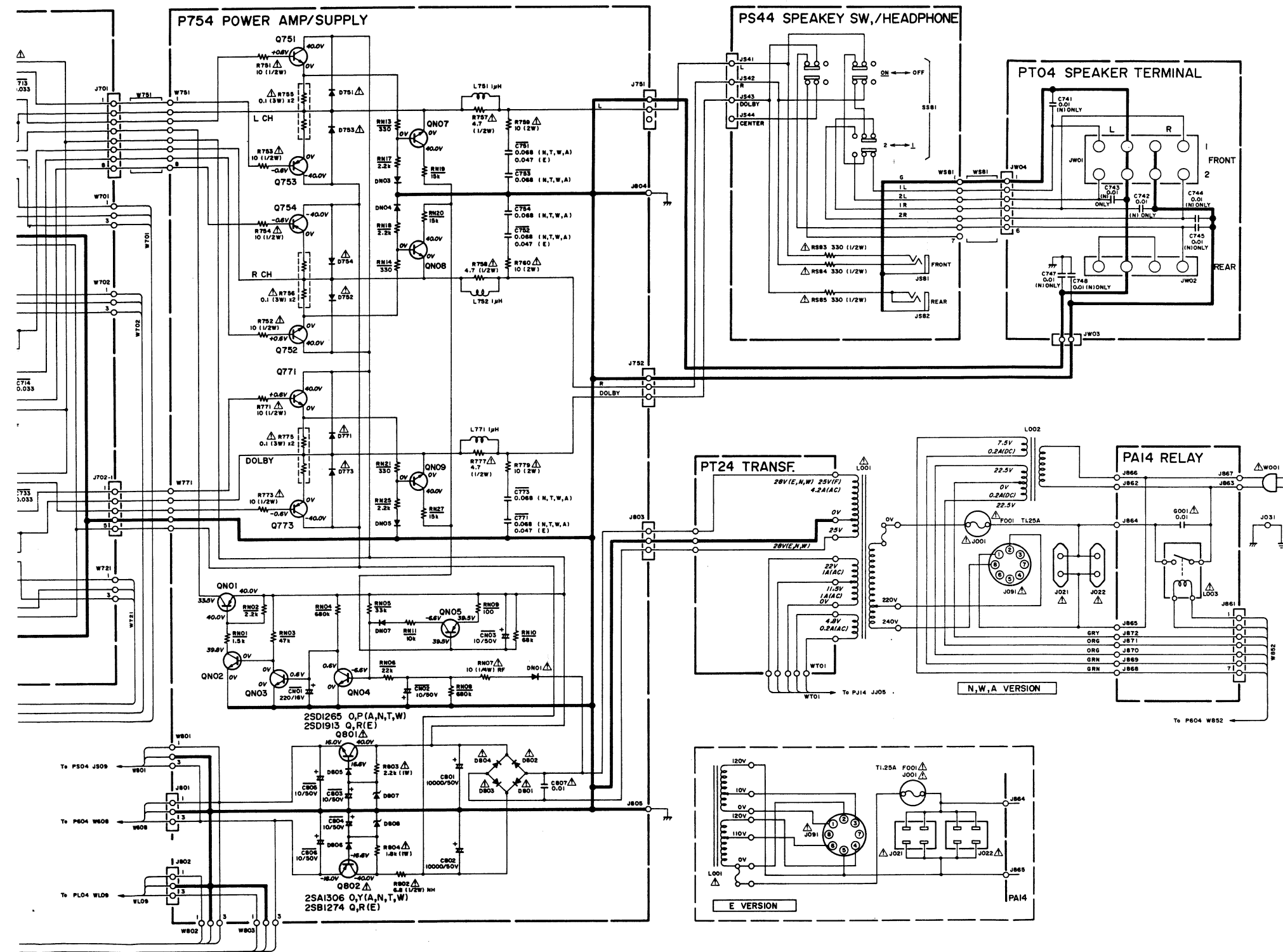

Q701, Q702, Q721  
HC10114060  
µPCI270H

Q703, Q704, Q723  
HT334191Y0  
2SC3419(Y)

Q751, Q752, Q771  
HT417142B0  
2SD1714(S,P)

Q753, Q754, Q773  
HT211592B0  
2SB1159(S,P)

Q801  
HT412652A0  
2SD1265(R,P)

Q802  
HT113062D0  
2SA1306(O,Y)

Q803  
HC39506090  
NJM79M06A

QN01  
HT10001000  
2SA608SP(F,G)

QN02, QN07~QN09  
HY327852D0  
2SC2785(FF,EF)

QN03, QN04  
HT30001000  
2SC536SP(F,G)

QN05  
HT111752D0  
2SA1175(FF,EF)

QN51~QN54, QN56  
QN58  
HT328781A0  
2SC2878(A)

Q804  
HC39506090  
NJM79M06

D751~D754, D771  
D773, DN01, DN02  
HD20003000  
DSF10C, etc.

D801~D804  
HD20011290  
S3V20

D805, D806  
DN03~DN05, DN07  
DN51~DN53  
HD20002000  
1S5133, etc.

D807, D808  
HD31601000  
16V

DN54  
HD31201000  
12V

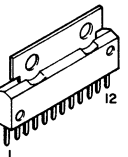
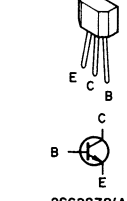
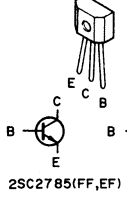
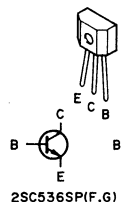
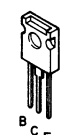

SCHEMATIC DIAGRAM OF PM683 (4/4)

µPCI270H



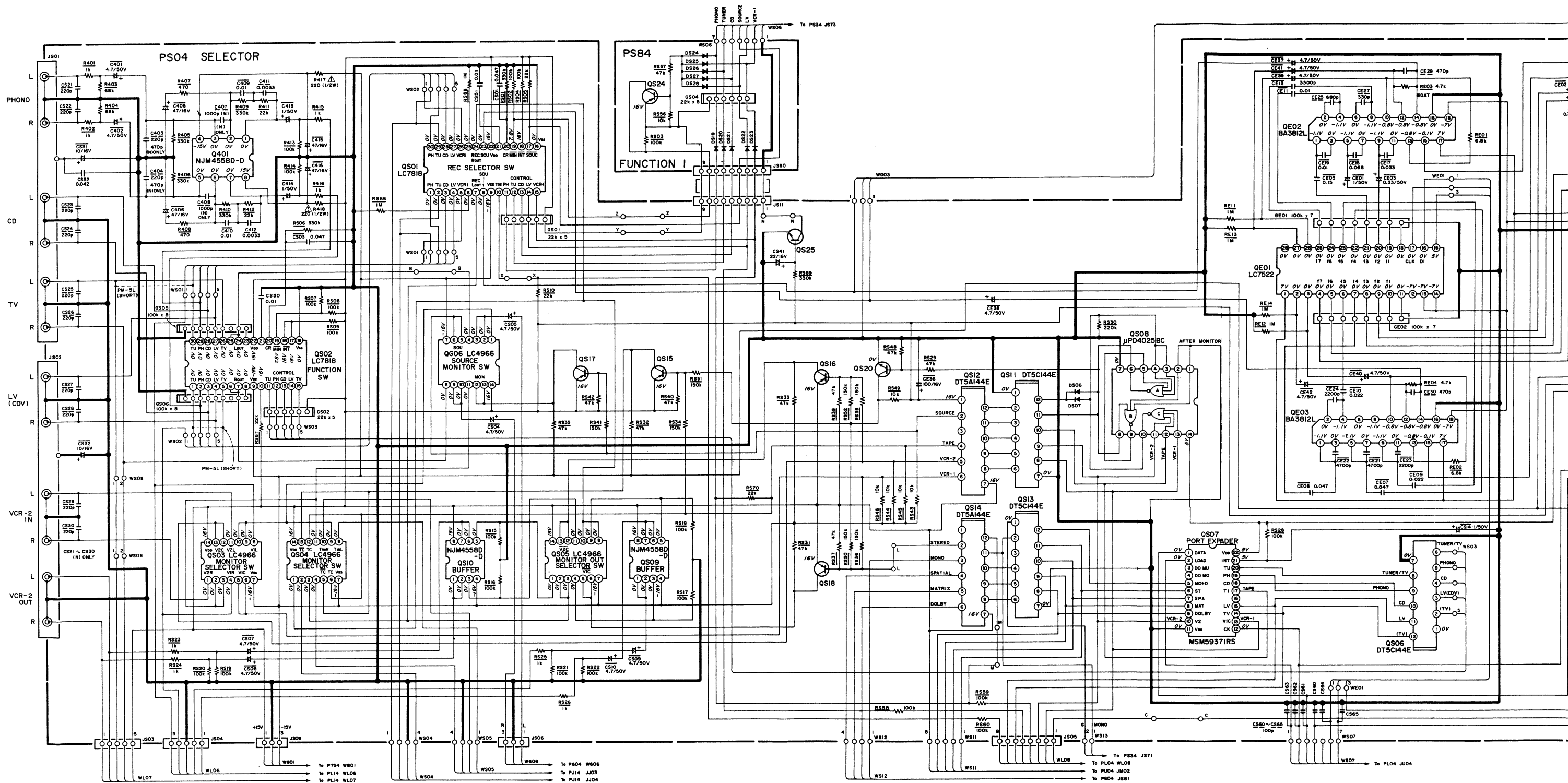

TOP VIEW  
 8 5  
  
 NJM4558D

TOP VIEW  
 14  
  
 μPD4025B

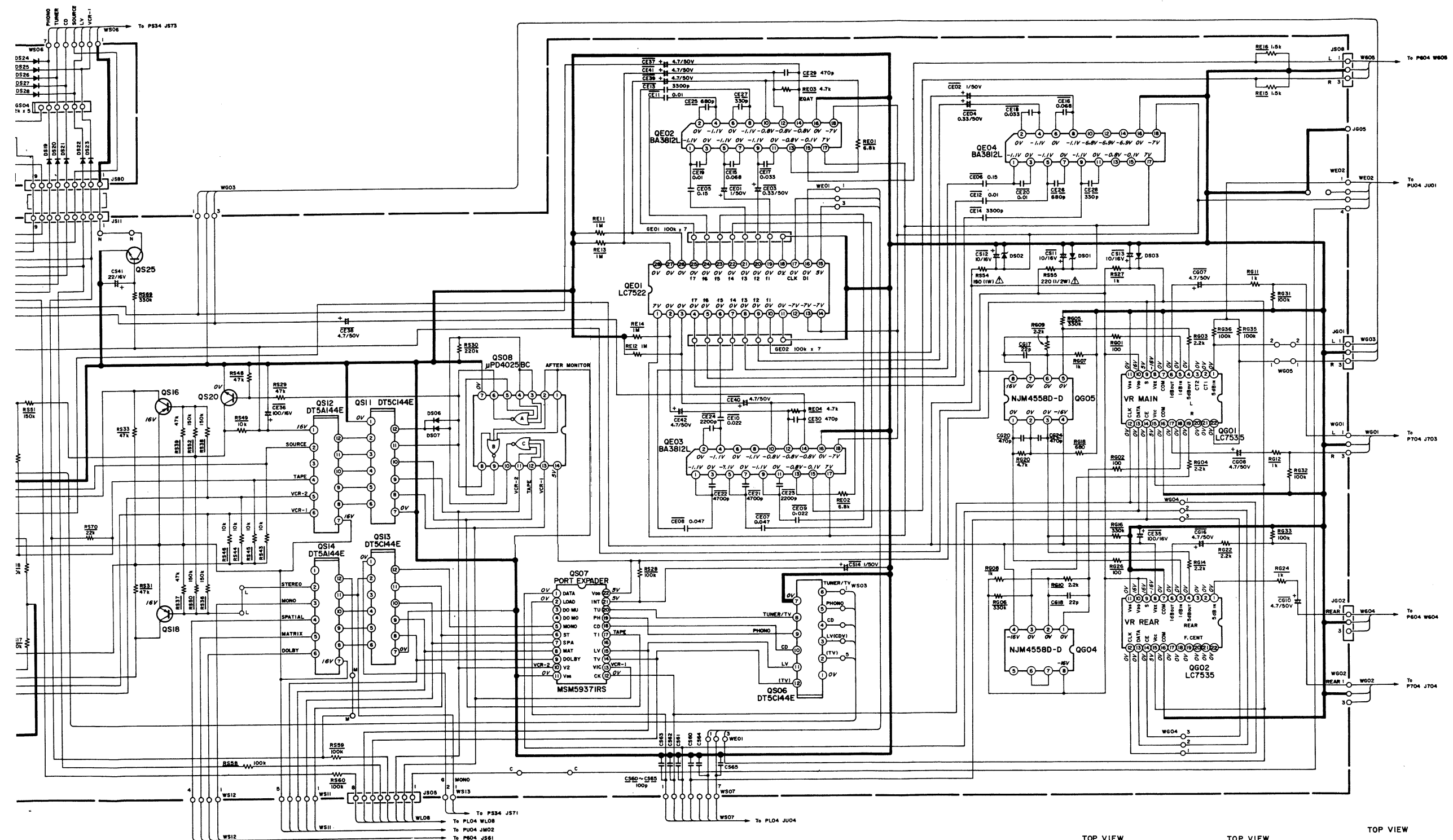

- QE01  
HC10216030  
LC7522
- QE02~QE04  
HC10052210  
BA3812L
- QG01  
HC10217030  
LC7535
- QG04, QG05, QG09  
QS10, Q401  
HC10008090  
NJM4558D-D
- QG06  
QS03~QS05  
HC10150030  
LC4966
- QS01, QS02  
HC10168030  
LC7818
- QS06, QS11, QS13  
HC10069210  
DT5C144E
- QS07  
HC10001260  
MSM5937IRS
- QS08  
HC402500B0  
μPD4025BC
- QS12, QS14  
HC10068210  
DT5A144E
- QS15~QS18  
QS24  
HT10001000  
2SA608SP(F,G)
- QS20, QS25  
HT30001000  
2SC536SP(F,G)
- DS01, DS02  
HD30681000  
6.8V
- DS03  
HD30511000  
5.1V
- DS04~DS07  
DS19~DS28  
HD20002000  
ISS133, etc.

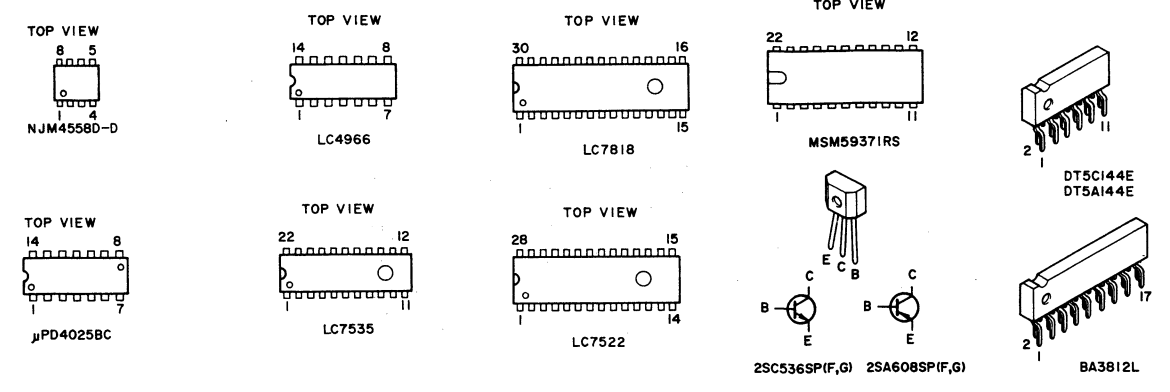



# PS04 - SELECTOR

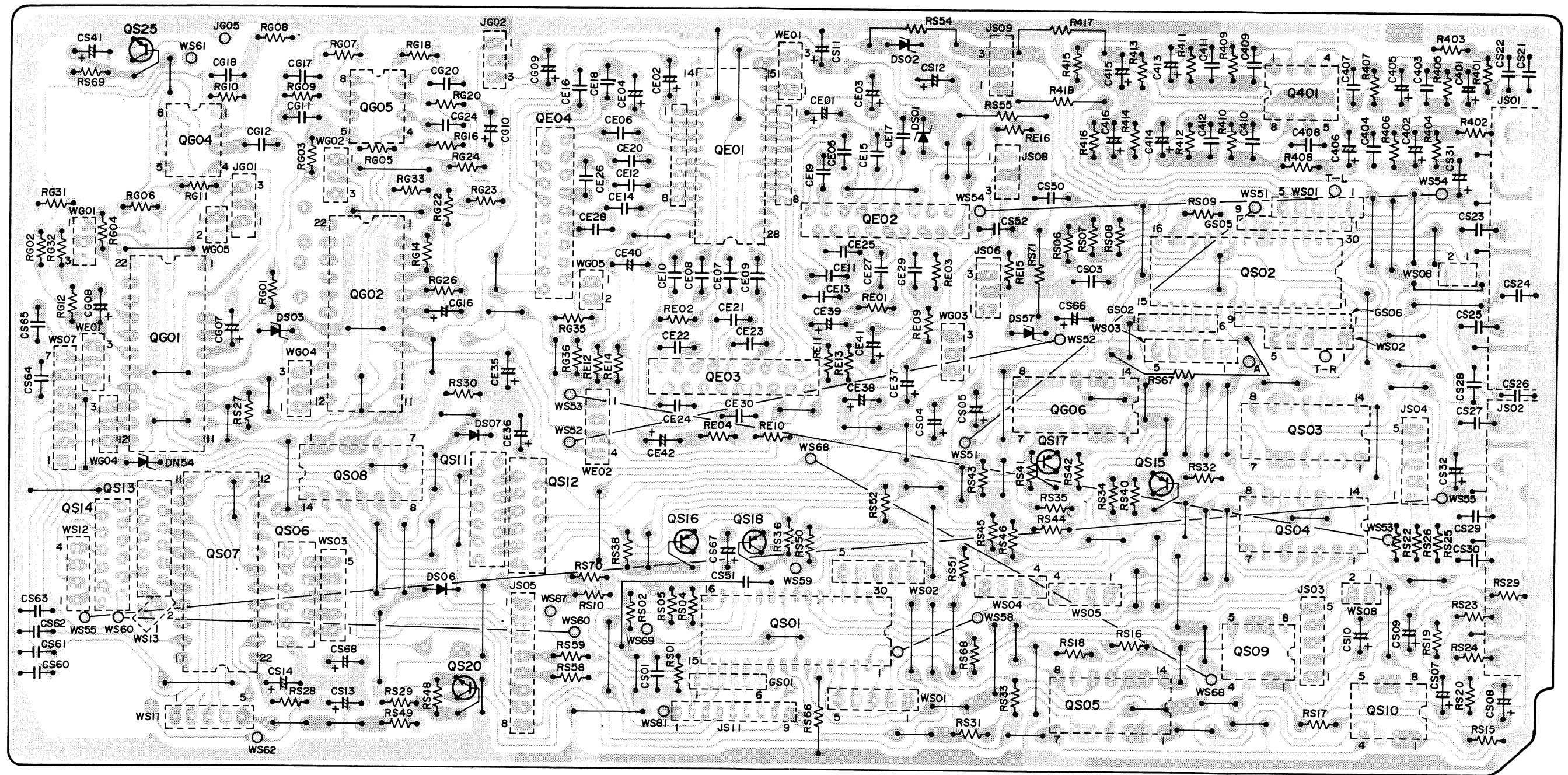

QSI4 QSI3 QG01 QS07 QS06 QS08 QSI1 QSI2 QSI6 QE03 QSI8 QSO1 QE02 QSI7 QG06 QS05 QSI5 QS02~QS04 QSI0  
 QS25 QG04 QG02 QG05 QS20 QE04 QSO1 QSO2 QSO3 QSO4 QSO5 QSO9 Q401

PU04 - μ-COM

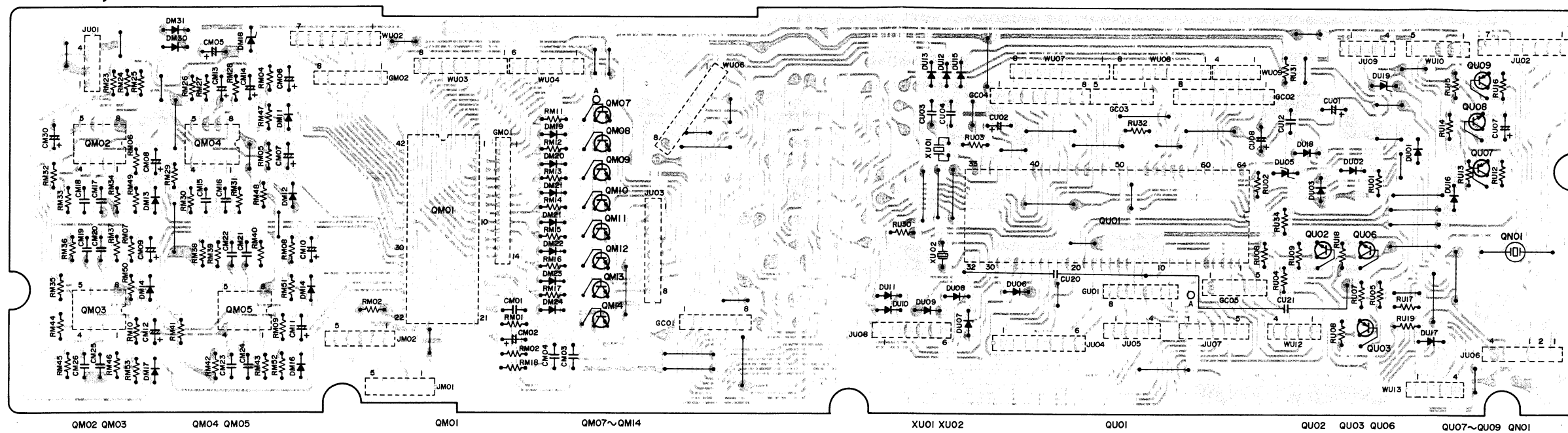

PU24 - TACT SWITCH

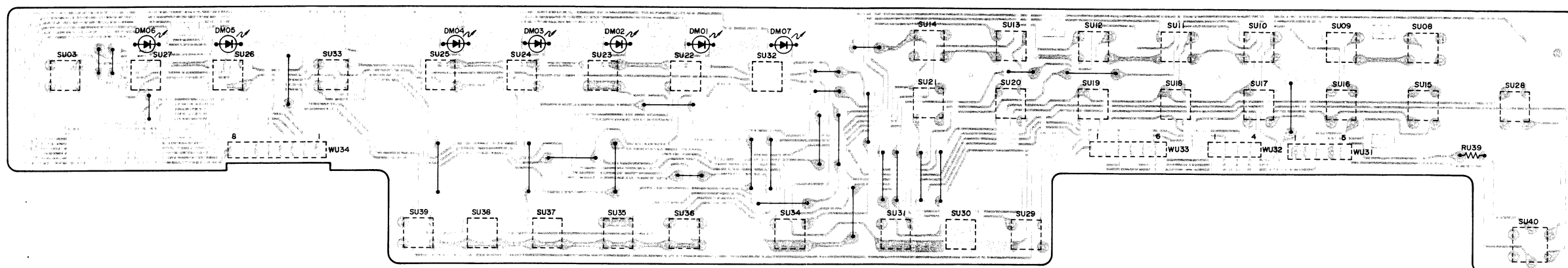

PUI4 - FIP

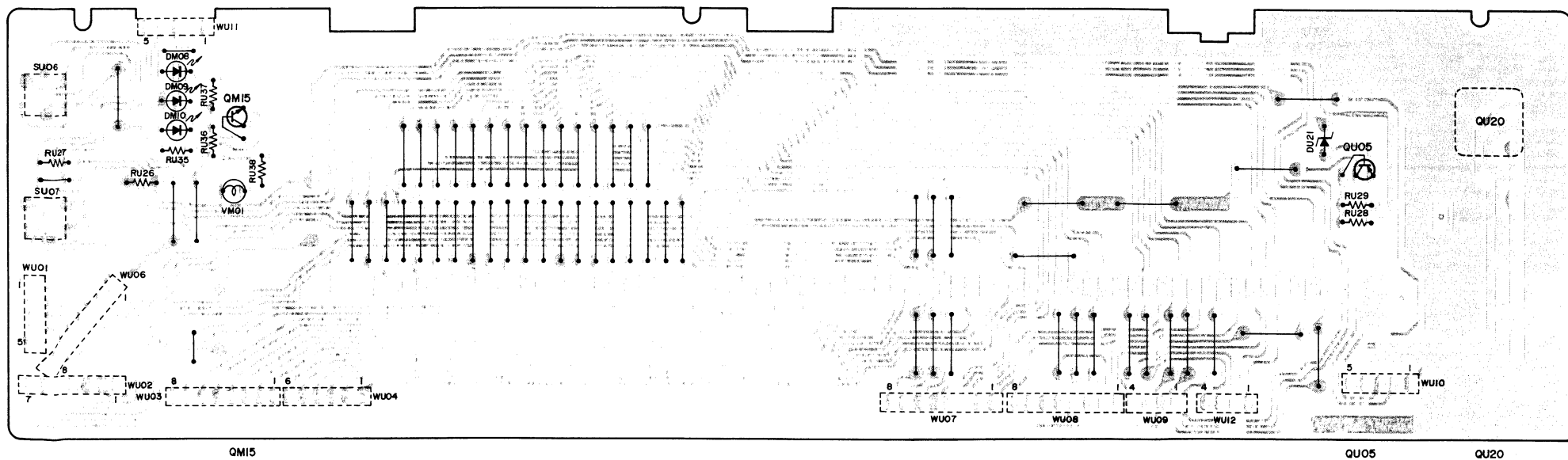

PU34 - TACT SWITCH

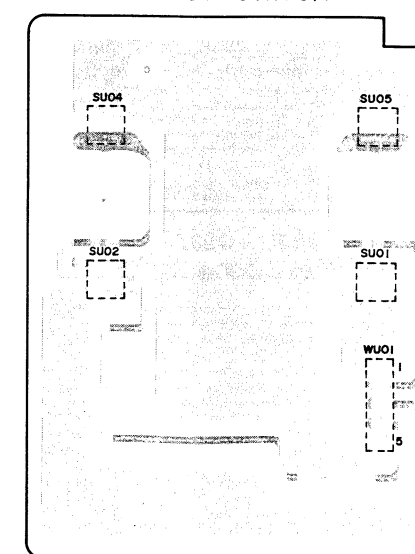





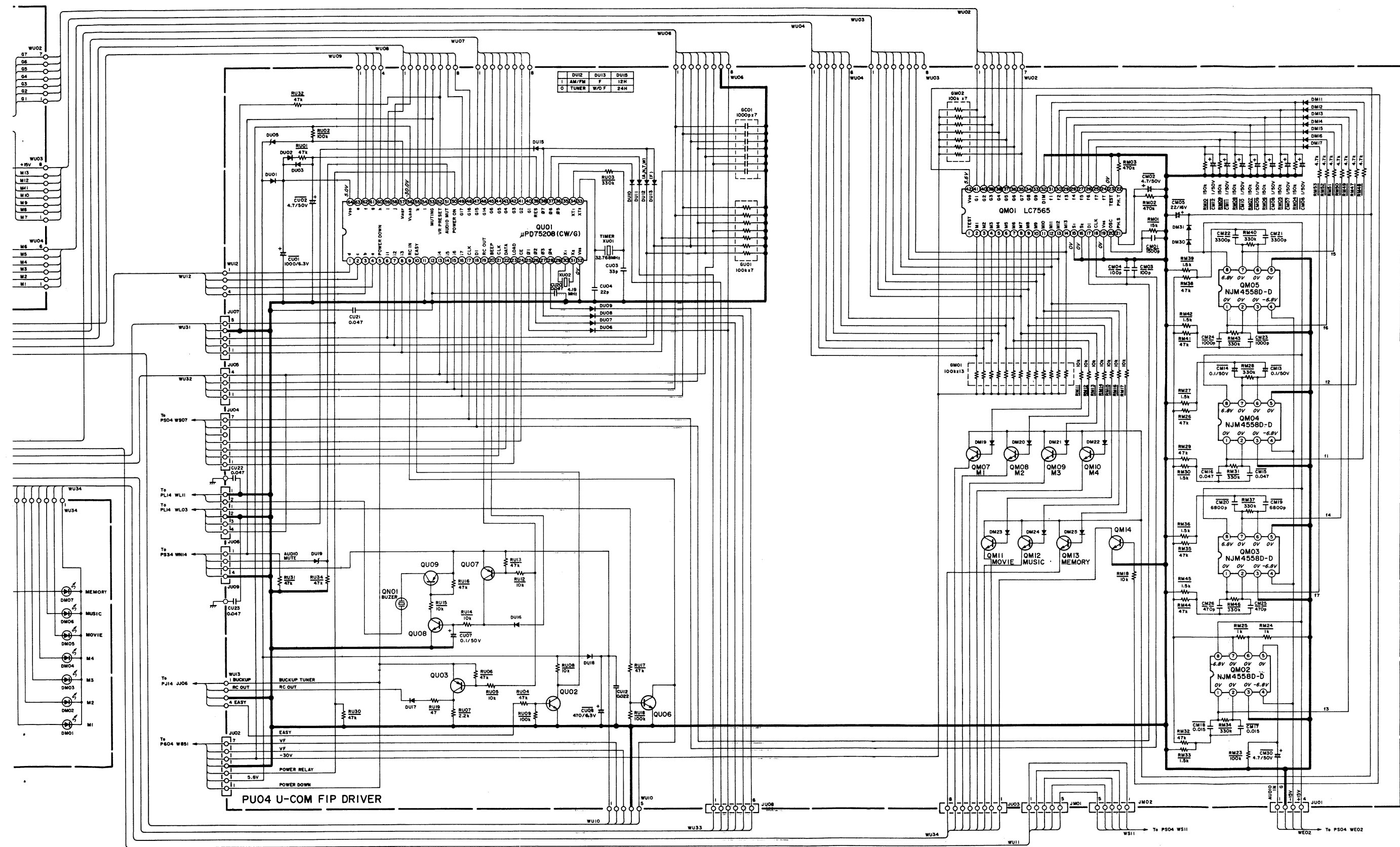

- QMO1  
HC10215030  
LC7565
- QMO2~QMO5  
HC10003090  
NJM4558DD
- QMO7~QMO15  
QU02, QU06  
QU08  
HT30001000  
25C536SP (F, G)
- QNO1  
ZUI0012020  
BUZZER
- QU01  
HUI0005060  
µPD75208
- QU03, QU05, QU07  
QU09,  
HT10001000  
25A608SP (F, G)
- DM01~DM10  
HI10062320  
LT3D88
- DM11~DM17, DM19~DM25  
DM30, DM31, DU01~DU03  
DU06~DU13, DU15~DU18  
ISSI33, etc.
- DU05  
HD30911000  
RD9.1JB2
- DU19  
HD30391000  
3.9V
- DU21  
HD30361000  
MTZJ3.6A

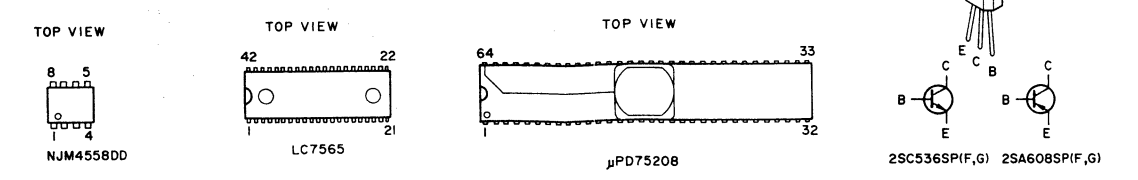

ASSIGNMENT OF COMMON PARTS CODES.

**RESISTOR**  
**R\*\*\*:** (1) GD05 --- 140, Carbon film fixed resistor, ±5%, 1/4W  
**R\*\*\*:** (2) GD05 --- 160, Carbon film fixed resistor, ±5%, 1/6W  
 ① — Resistance value

**Examples**  
 ① Resistance value  
 0.1Ω...001 10Ω...100 1kΩ...102 100kΩ...104  
 0.5Ω...005 18Ω...180 2.7kΩ...272 680kΩ...684  
 1Ω...010 100Ω...101 10kΩ...103 1MkΩ...105  
 6.8Ω...068 390Ω...391 22kΩ...223 4.7MkΩ...475

(Note) Please distinguish 1/4W from 1/6W by the shape of parts used actually.

**C\*\*\*: CERAMIC CAP.**  
 (1) DD1 --- 370, Ceramic condenser  
 Disc type  
 Temp. coeff. P350 ~ N1000, 50V  
 ① ②  
 Capacity value  
 Tolerance

**Examples**  
 ① Tolerance (Capacity deviation)  
 ±0.25pF...0  
 ±0.5pF...1  
 ±5%...5  
 \* Tolerance of COMMON PARTS handled here are as follows:  
 0.5pF ~ 5pF...±0.25pF  
 6pF ~ 10pF...±0.5pF  
 12pF ~ 560pF...±5%  
 ② Capacity value  
 0.5pF...005 3pF...030 100pF...101  
 1pF...010 10pF...100 220pF...221  
 1.5pF...015 47pF...470 560pF...561

**C\*\*\*: CERAMIC CAP.**  
 (1) DK16 --- 300, High dielectric constant ceramic condenser  
 Disc type  
 Temp. chara. 2B4, 50V  
 ①  
 Capacity value

**Example**  
 ② Capacity value  
 100pF...101 1000pF...102 10000pF...103  
 470pF...471 2200pF...222

**C\*\*\*: ELECTROLY CAP. (E), FILM CAP. (F)**  
 (1) EA --- 10, Electrolytic condenser  
 One-way lead type, Tolerance ±20%  
 ① ②  
 Dielectric strength  
 Capacity value

**Examples**  
 ① Capacity value  
 0.1μF...104 4.7μF...475 100μF...107  
 0.33μF...334 10μF...106 330μF...337  
 1μF...105 22μF...226 1100μF...108  
 2200μF...228  
 ② Working voltage  
 6.3V...006 25V...025  
 10V...010 35V...035  
 16V...016 50V...050

(2) DF15 --- 350, Plastic film condenser  
 One-way type, Mylar ±5% 50V  
 ①  
 Capacity value

**Examples**  
 ① Capacity value  
 0.001μF (1000pF)...102 0.1μF...104  
 0.0018μF...182 0.56μF...564  
 0.01μF...103 1μF...105  
 0.015μF...153

5. ELECTRICAL PARTS LIST

REF. DESIG.	PART NO.	DESCRIPTION	REF. DESIG.	PART NO.	DESCRIPTION	REF. DESIG.	PART NO.	DESCRIPTION	REF. DESIG.	PART NO.	DESCRIPTION
G001	4822 122 40305	<b>PA14-RELAY CIRCUIT BOARD</b> Ceramic Cap. 0.01μF 400V	QL29	4822 130 42298	<b>PL24-R.G.B. CONNECTOR CIRCUIT BOARD</b> Transistor 2SC536SP(F, G), etc.	RS91	4822 100 20614	<b>PS34-REC SELECTOR CIRCUIT BOARD</b> Variable Resistor 100KΩ(B)	DM11		
L003	4822 280 70219 4822 280 70331	Relay [N, W, A] Relay [E]	JL20	4822 266 30307	Terminal, 21P; RGB	SS71	4822 276 20458	Push Switch, Surround	DM17		
JJ01	4822 266 30305	<b>PJ14-CONNECTOR CIRCUIT BOARD</b> Terminal, 10P	JL21	4822 266 30307	Terminal, 21P; RGB	SS72	4822 273 70114	Rotary Switch, Speaker	DM19		4822 130 33305
JJ02	4822 266 30306	Terminal, 13P							DM25		
CL33	4822 122 40306	Ceramic Cap. 0.047μF +80% -20%				Δ RS83	4822 111 90724	<b>PS44-SPEAKER SW. CIRCUIT BOARD</b> Resistor 330Ω ±5% 1/4W	DM30	4822 130 33305	
CL35	4822 122 40617	Ceramic Cap. 0.1μF +80% -20%	CS50	4822 122 32486	<b>PS04-SELECTOR CIRCUIT BOARD</b> Ceramic 0.01μF +80% -20%	Δ RS84	4822 111 90724	Resistor 330Ω ±5% 1/4W	DM31	4822 130 33305	
CL37	4822 122 40617	Ceramic Cap. 0.1μF +80% -20%	CS51	4822 122 32486	Ceramic 0.01μF +80% -20%	Δ RS85	4822 111 90724	Resistor 330Ω ±5% 1/4W	DU01	4822 130 33305	
CL04	4822 122 40297	<b>PL04-VIDEO AMP CIRCUIT BOARD</b> Ceramic 2pF ±0.25pF	CS52	4822 122 40306	Ceramic 0.047μF +80% -20%	JS81	4822 267 30834	Jack, Headphone	DU02	4822 130 33305	
CL07	4822 122 40297	Ceramic 2pF ±0.25pF	GE01	4822 111 91398	<b>PS04-CAPACITORS</b> Ceramic 0.01μF +80% -20%	JS82	4822 267 30834	Jack, Headphone	DU03	4822 130 33305	
CL10	4822 122 40297	Ceramic 2pF ±0.25pF	GE02	4822 111 91398	Ceramic 0.01μF +80% -20%	SS81	4822 276 20459	Push Switch, Speaker	DU05	4822 130 80319	
DL01	4822 130 33305	<b>PL04-CAPACITOR</b> Ceramic 2pF ±0.25pF	GS01	4822 111 91401	Ceramic 0.047μF +80% -20%				DU06		4822 130 33305
DL02	4822 130 33305	Ceramic 2pF ±0.25pF	GS02	4822 111 91401	<b>PS04-RESISTORS</b> 100KΩx7 Composite	GS04	4822 111 91401	Resistor Composite 22KΩx5	DU12		
DL03	4822 130 33305	Diode 1SS133, etc.	GS05	4822 111 91513	100KΩx7 Composite	DS19			DU15		
DL04	4822 130 33305	Diode 1SS133, etc.	GS06	4822 111 91513	22KΩx5 Composite	DS28			DU18		
DL05	4822 130 33305	Diode 1SS133, etc.	Δ RS54	4822 116 60337	22KΩx5 Composite	QS24	4822 130 42715	Diode 1SS133, etc.	DU19	4822 130 80132	
DL06	4822 130 33305	Diode 1SS133, etc.	Δ RS55	4822 116 52849	100KΩx8 Composite	QS25	4822 130 42298	Transistor 2SA608SP(F, G), etc.	QM01	4822 209 71782	
DL07	4822 130 33305	Diode 1SS133, etc.	Δ RS71	4822 116 52849	150Ω ±5% 1W				QM02	4822 209 80401	
DL09	4822 130 33305	Diode 1SS133, etc.	Δ R417	4822 116 52849	220Ω ±5% 1/2W				QM03	4822 209 80401	
DL10	4822 130 33305	Diode 1SS133, etc.	Δ R418	4822 116 52849	220Ω ±5% 1/2W				QM04	4822 209 80401	
QL01	4822 209 83067	<b>PL04-SEMICONDUCTORS</b> Diode 1SS133, etc.	DS01	4822 130 80318	220Ω ±5% 1/2W				QM05	4822 209 80401	
QL02	4822 209 83067	Diode 1SS133, etc.	DS02	4822 130 80318	220Ω ±5% 1/2W				QM07		4822 130 42298
QL03	4822 209 83832	Diode 1SS133, etc.	DS03	4822 130 80317	150Ω ±5% 1W				QM14		
QL04	4822 209 71781	Diode 1SS133, etc.	DS06	4822 130 33305	220Ω ±5% 1/2W				QN01	4822 280 10191	
QL05		Diode 1SS133, etc.	DS07	4822 130 33305	220Ω ±5% 1/2W				QU01	4822 209 71787	
QL08		Diode 1SS133, etc.	DS08	4822 130 80932	220Ω ±5% 1/2W				QU02	4822 130 42298	
QL09		Diode 1SS133, etc.	DS09	4822 130 33305	Zener RD6.8J				QU03	4822 130 42715	
QL12		Diode 1SS133, etc.	DS10	4822 130 80932	Zener RD6.8J				QU06	4822 130 42715	
QL13		Diode 1SS133, etc.	DS11	4822 130 80932	Zener RD5.1J				QU07	4822 130 42715	
QL22		Diode 1SS133, etc.	DS12	4822 130 80932	Diode 1SS133				QU08	4822 130 42298	
QL23	4822 130 42715	Diode 1SS133, etc.	DS13	4822 130 80932	Diode 1SS133				QU09	4822 130 42715	
QL24	4822 130 42715	Diode 1SS133, etc.	DS14	4822 130 80932	Zener RD6.2J						
QL25	4822 130 42715	Diode 1SS133, etc.	DS15	4822 130 80932	Zener RD6.2J						
QL26	4822 130 42298	Transistor 2SC536SP(F, G), etc.	DS16	4822 130 80932	Zener RD6.2J						
QL27	4822 130 42715	Transistor 2SA608SP(F, G), etc.	DS17	4822 130 80932	Zener RD6.2J						
QL28	4822 130 42298	Transistor 2SC536SP(F, G), etc.	DS18	4822 130 80932	Zener RD6.2J						
JL01	4822 266 30301	<b>PL14-PIN JACK/SW. CIRCUIT BOARD</b> Transistor 2SC536SP(F, G), etc.	QE01	4822 209 71783	IC LC7522						
JL02	4822 266 30302	Transistor 2SA608SP(F, G), etc.	QE02	4822 209 83338	IC BA3812L						
JL03	4822 266 30304	Transistor 2SA608SP(F, G), etc.	QE03	4822 209 83338	IC BA3812L						
JL04	4822 266 30236	Transistor 2SA608SP(F, G), etc.	QE04	4822 209 83338	IC BA3812L						
SL01	4822 277 21146	<b>PL14-SEMICONDUCTORS</b> Transistor 2SC536SP(F, G), etc.	QG01	4822 209 71784	IC LC7535						
SL02	4822 277 21146	Transistor 2SA608SP(F, G), etc.	QG02	4822 209 71784	IC LC7535						
SL03	4822 277 21146	Transistor 2SC536SP(F, G), etc.	QG04	4822 209 83631	IC NJM4558D-D						
SL04	4822 277 21146	Transistor 2SC536SP(F, G), etc.	QG05	4822 209 83631	IC NJM4558D-D						
JL01	4822 266 30301	<b>PL14-MISCELLANEOUS</b> Terminal, 2P; RCA	QG06	4822 209 83804	IC LC4966						
JL02	4822 266 30302	Terminal, 3P; RCA	QS01	4822 209 83315	IC LC7818						
JL03	4822 266 30304	Terminal, 6P; RCA	QS02	4822 209 83315	IC LC7818						
JL04	4822 266 30236	Terminal, 2P; RCA	QS03	4822 209 83804	IC LC4966						
SL01	4822 277 21146	Slide Switch	QS04	4822 209 83804	IC LC4966						
SL02	4822 277 21146	Slide Switch	QS05	4822 209 83804	IC LC4966						
SL03	4822 277 21146	Slide Switch	QS06	4822 209 71779	IC DT5C144E						
SL04	4822 277 21146	Slide Switch	QS07	4822 209 83594	IC MSM59371RS						
			QS08	4822 209 83836	IC μPD4025BC						
			QS09	4822 209 83631	IC NJM4558D-D						
			QS10	4822 209 83631	IC NJM4558D-D						
			QS11	4822 209 71779	IC DT5C144E						
			QS12	4822 209 71778	IC DT5A144E						
			QS13	4822 209 71779	IC DT5C144E						
			QS14	4822 209 71778	IC DT5A144E						
			QS15	4822 130 42715	Transistor 2SA608SP(F, G), etc.						
			QS16	4822 130 42715	Transistor 2SA608SP(F, G), etc.						
			QS17	4822 130 42715	Transistor 2SA608SP(F, G), etc.						
			QS18	4822 130 42715	Transistor 2SA608SP(F, G), etc.						
			QS20	4822 130 42298	Transistor 2SC536SP(F, G), etc.						
			Q401	4822 209 83631	IC NJM4558D-D						
			JS01	4822 265 30457	<b>PS04-MISCELLANEOUS</b> Terminal, 6P; RCA						
			JS02	4822 265 30457	Terminal, 6P; RCA						



REF. DESIG.	PART NO.	DESCRIPTION
Q703	4822 130 60117	<b>P714-TRANSISTOR (L-CH) CIRCUIT BOARD</b> Transistor 2SC3419(Y)
Q704	4822 130 60117	<b>P724-TRANSISTOR (R-CH) CIRCUIT BOARD</b> Transistor 2SC3419(Y)
Q723	4822 130 60117	<b>P734-TRANSISTOR (DOLBY) CIRCUIT BOARD</b> Transistor 2SC3419(Y)
		<b>P754-POWER AMP/SUPPLY CIRCUIT BOARD</b>
		<b>P754-CAPACITORS</b>
C801	4822 124 21861	Elect 10000 $\mu$ F 50V
C802	4822 124 21861	Elect 10000 $\mu$ F 50V
△C807	4822 122 30043	Ceramic 0.01 $\mu$ F +80% -20%
		<b>P754-RESISTORS</b>
△RN07	4822 116 60314	10 $\Omega$ $\pm$ 5% 1/4W, Fusible
△R751	4822 116 52332	10 $\Omega$ $\pm$ 5% 1/2W
△R752	4822 116 52332	10 $\Omega$ $\pm$ 5% 1/2W
△R753	4822 116 52332	10 $\Omega$ $\pm$ 5% 1/2W
△R754	4822 116 52332	10 $\Omega$ $\pm$ 5% 1/2W
△R755	4822 111 91402	0.1 $\Omega$ x2 3W
△R756	4822 111 91402	0.1 $\Omega$ x2 3W
△R757	4822 116 52858	4.7 $\Omega$ $\pm$ 5% 1/2W
△R758	4822 116 52858	4.7 $\Omega$ $\pm$ 5% 1/2W
△R759	4822 111 90726	10 $\Omega$ $\pm$ 5% 2W
△R760	4822 111 90726	10 $\Omega$ $\pm$ 5% 2W
△R771	4822 116 52332	10 $\Omega$ $\pm$ 5% 1/2W
△R773	4822 116 52332	10 $\Omega$ $\pm$ 5% 1/2W
△R775	4822 111 91402	0.1 $\Omega$ x2 3W
△R777	4822 116 52858	4.7 $\Omega$ $\pm$ 5% 1/2W
△R779	4822 111 90726	10 $\Omega$ $\pm$ 5% 2W
△R802	4822 111 20384	6.8 $\Omega$ $\pm$ 5% 1/2W, Fusible
△R803	4822 116 60346	2.2K $\Omega$ $\pm$ 5% 1W
△R804	4822 116 60343	1.8K $\Omega$ $\pm$ 5% 1W
		<b>P754-SEMICONDUCTORS</b>
△DN01	4822 130 32508	Diode DSF 10C, etc.
DN03	4822 130 33305	Diode 1SS133, etc.
DN04	4822 130 33305	Diode 1SS133, etc.
DN05	4822 130 33305	Diode 1SS133, etc.
DN07	4822 130 33305	Diode 1SS133, etc.
△D751	4822 130 32508	Diode DSF 10C, etc.
△D752	4822 130 32508	Diode DSF 10C, etc.
△D753	4822 130 32508	Diode DSF 10C, etc.
△D754	4822 130 32508	Diode DSF 10C, etc.
△D771	4822 130 32508	Diode DSF 10C, etc.
△D773	4822 130 32508	Diode DSF 10C, etc.
△D801	4822 130 33074	Diode 30DF-2
△D802	4822 130 33074	Diode 30DF-2
△D803	4822 130 33074	Diode 30DF-2
△D804	4822 130 33074	Diode 30DF-2
D805	4822 130 33305	Diode 1SS133, etc.
D806	4822 130 33305	Diode 1SS133, etc.
D807	4822 130 80498	Zener RD16J
D808	4822 130 80498	Zener RD16J

REF. DESIG.	PART NO.	DESCRIPTION
QN01	4822 130 42715	Transistor 2SA608SP(F, G)
QN02	4822 130 42052	Transistor 2SC2785(FF, EF)
QN03	4822 130 42298	Transistor 2SC2458, etc.
QN04	4822 130 42298	Transistor 2SC2458, etc.
QN05	4822 130 42591	Transistor 2SA1175(FF, EF)
QN07	4822 130 42052	Transistor 2SC2785(FF, EF)
QN08	4822 130 42052	Transistor 2SC2785(FF, EF)
QN09	4822 130 42052	Transistor 2SC2785(FF, EF)
Q751	4822 130 60698	Transistor 2SD1714(S, P)
Q752	4822 130 60698	Transistor 2SD1714(S, P)
Q753	4822 130 60695	Transistor 2SB1159(S, P)
Q754	4822 130 60695	Transistor 2SB1159(S, P)
Q771	4822 130 60698	Transistor 2SD1714(S, P)
Q773	4822 130 60695	Transistor 2SB1159(S, P)
△Q801	4822 130 42073	Transistor 2SD1265(O,P)[N,W,A]
	4822 130 61364	Transistor 2SD1913(Q,R)[E]
△Q802	4822 130 43023	Transistor 2SA1306(O,Y)[N,W,A]
	4822 130 61359	Transistor 2SB1274(Q,R)[E]
		<b>P754-MISCELLANEOUS</b>
L751	4822 157 51739	Coil, 1 $\mu$ H
L752	4822 157 51739	Coil, 1 $\mu$ H
L771	4822 157 51739	Coil, 1 $\mu$ H
		<b>P801-REGULATOR CIRCUIT BOARD</b>
△Q803	4822 209 83821	IC NJM78M06FA
		<b>P802-REGULATOR CIRCUIT BOARD</b>
△Q804	4822 209 72332	IC NJM79M06FA

**NOTE ON SAFETY:**

Symbol  $\Delta$  Fire or electrical shock hazard. Only original parts should be used to replace any part marked with symbol  $\Delta$ . Any other component substitution (other than original type), may increase risk of fire or electrical shock hazard.

REF. DESIG.	PART NO.	DESCRIPTION
001B	4822 443 40758	Front Panel Assembly
009B	4822 454 11967	Escutcheon, Hinge
010B	4822 412 20998	Knob, Hinge
014B	4822 454 30391	Indicator Assembly
020B	4822 410 25819	Button, Volume
021B	4822 535 71094	Pin, Volume
023B	4822 410 25821	Button, EQ
025B	4822 410 25822	Button, Surround
027B	4822 410 25823	Button, Mode
028B	4822 532 51719	Bushing, Power Switch
029B	4822 410 25829	Button K, Power Switch
032B	4822 410 25825	Button, Timer
034B	4822 410 25826	Button, Timer Mode
036B	4822 410 25827	Button, Clear
038B	4822 410 25828	Button, EQ Flat
040B	4822 410 25782	Button, Tact
042B	4822 381 10895	Lens, Muting
043B	4822 532 51719	Bushing, Muting
045B	4822 410 25783	Button, Push
046B	4822 412 20997	Knob, Volume
051B	4822 466 61642	Spacer
065B	4822 417 10985	Hinge, Left
066B	4822 417 10986	Hinge, Right
067B	4822 278 80277	Contactactor
068B	4822 278 80281	Contactactor
070B	4822 526 50097	Click, Right
071B	4822 526 50096	Click, Left

4. EXPLODED VIEW AND PARTS LIST

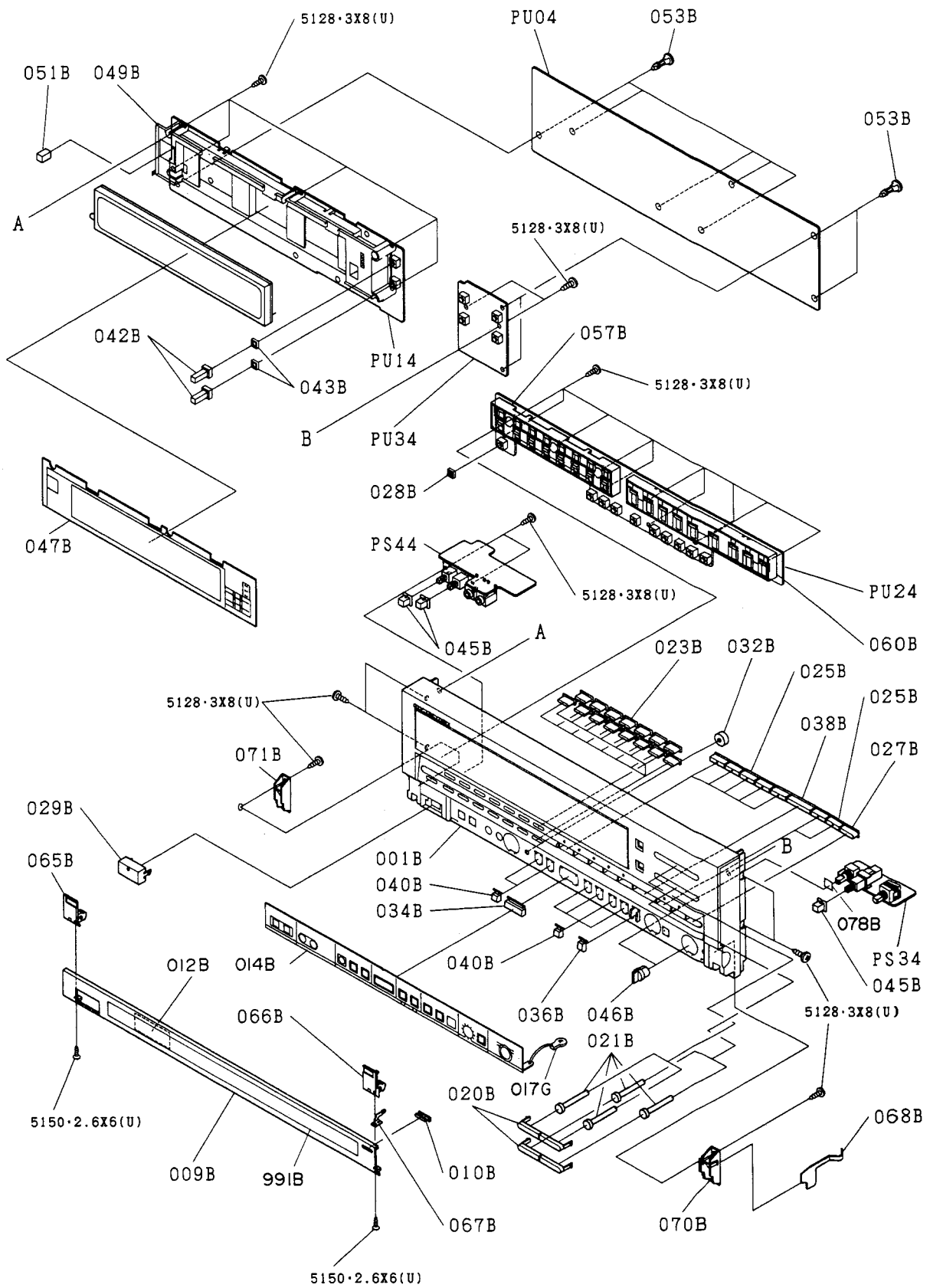

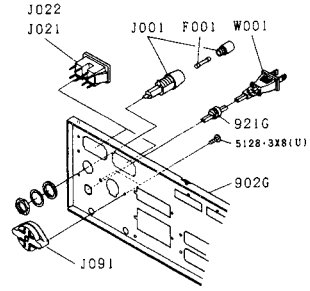
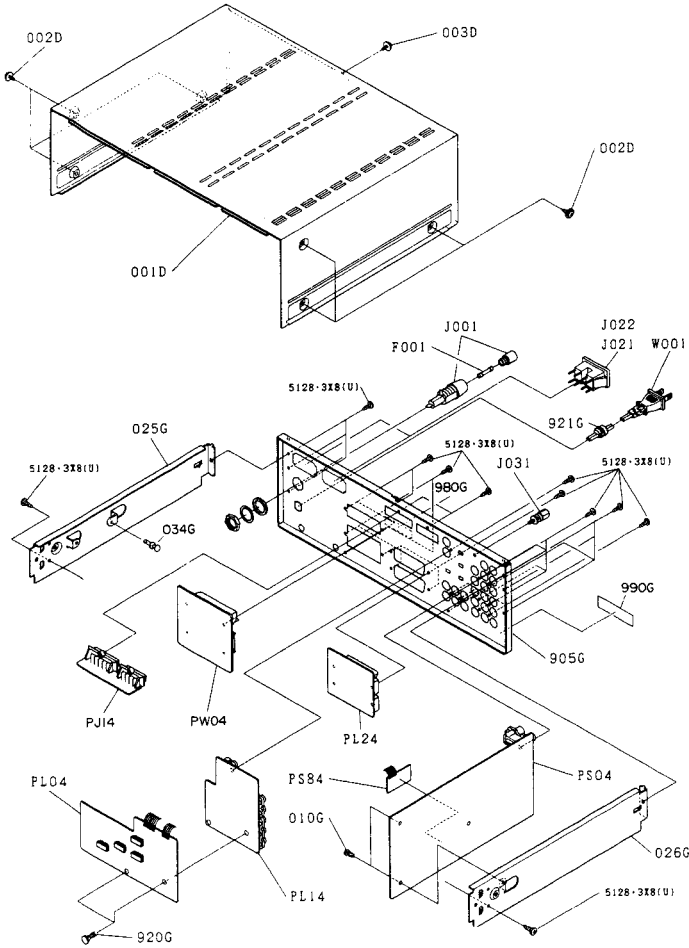

(E) TYPE

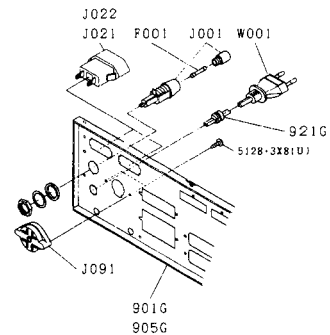

(N,W) TYPE

REF. DESIG.	PART NO.	DESCRIPTION
001D	4822 426 51233	Lid, Top Cover
002D	4822 502 12355	B.T. Screw B3 x 8
003D	4822 502 12355	B.T. Screw B3 x 8
△ F001	4822 253 30022	Fuse T1.25A 250V
△ J001	4822 256 30233	Jack, Fuse Holder
△ J021	4822 267 30597	Jack, AC Outlet [N, W, A]
	4822 265 10091	Jack, AC Outlet [E]
△ J022	4822 267 30597	Jack, AC Outlet [N, W, A]
	4822 265 10091	Jack, AC Outlet [E]
J031	4822 290 40297	Terminal, GND
△ J091	4822 272 10236	Voltage Selector [N, W, A]
	4822 272 10235	Voltage Selector [E]

REF. DESIG.	PART NO.	DESCRIPTION
001T	4822 736 20153	User Manual
Z004	4822 218 10203	Remocon Unit (RMC-73)
Z006	4822 138 10155	Battery, SUM-3
Z007	4822 321 22384	Connective Cord, 10P
Z008	4822 321 22385	Connective Cord, 13P
Z009	4822 253 30026	Fuse [E]
Z010	4822 265 10092	Jack, AC Adaptor [E]

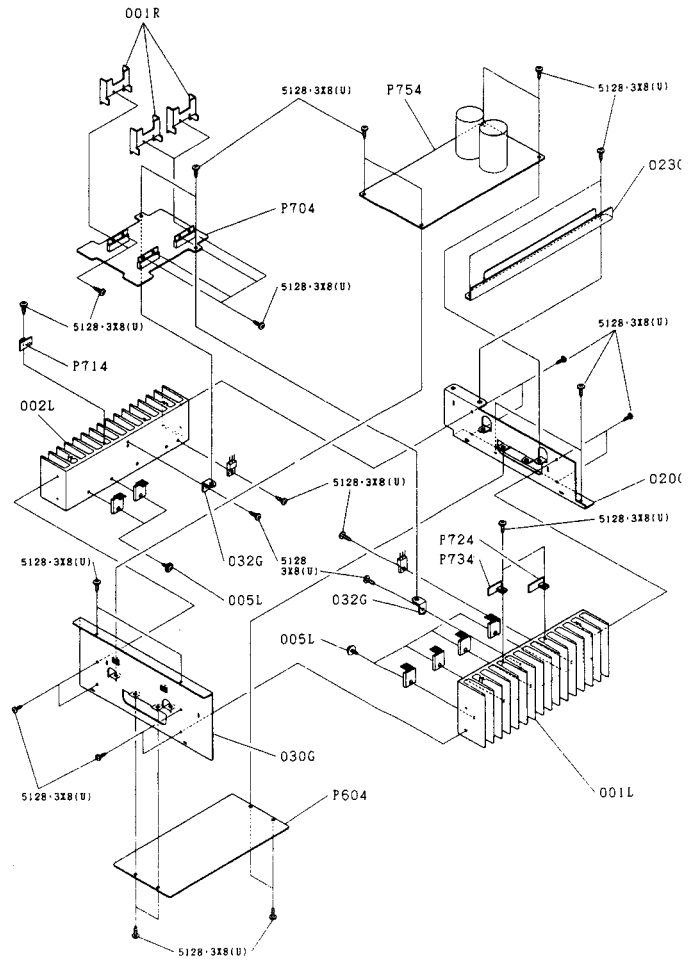
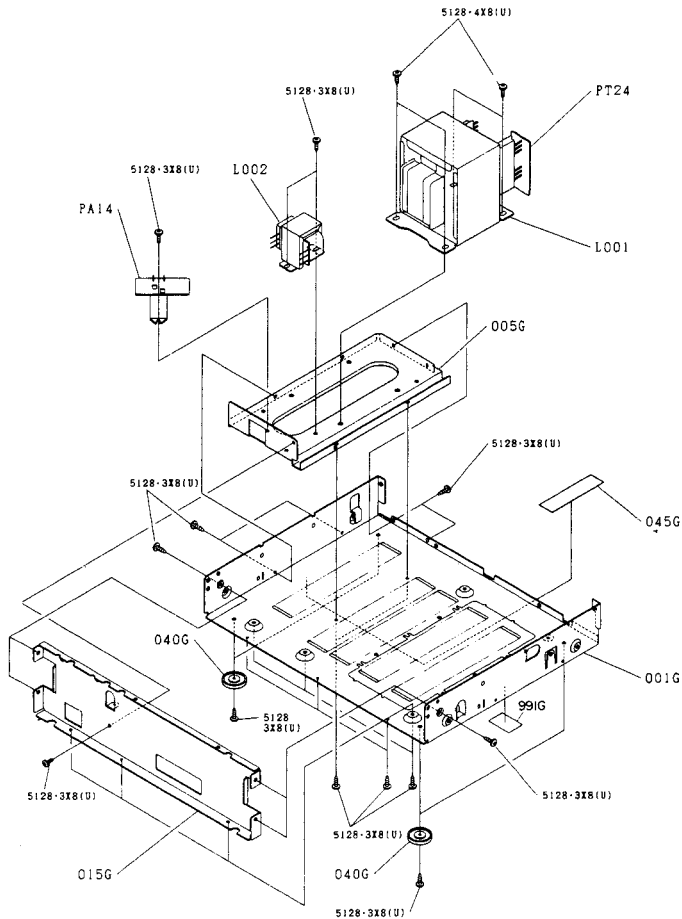

REF. DESIG.	PART NO.	DESCRIPTION
040G	4822 462 41186	Leg

REF. DESIG.	PART NO.	DESCRIPTION
△L001	4822 148 60173	Power Transformer, Main [N,W,A]
	4822 148 60175	Power Transformer, Main [E]
△L002	4822 148 60166	Power Transformer, Sub [N,W,A]
	4822 148 60174	Power Transformer, Sub [E]