

Service Manual

PM7200 / N1B/N1G
Integrated Amplifier

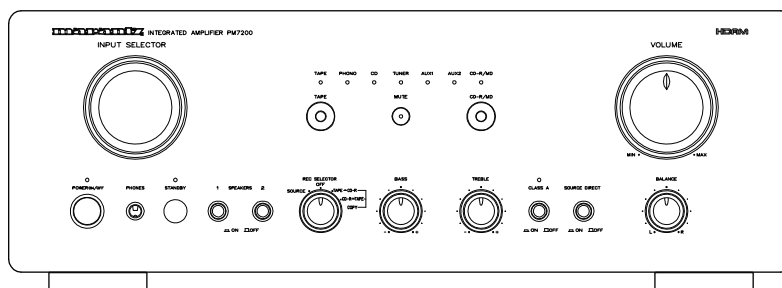

PM7200

POS. NO.	VERS. COLOR	PART NO. (FOR EUR)	DESCRIPTION	PART NO. (MJI)
200	/N1B	20AW248010	FRONT PANEL BLACK	20AW248010
200	/N1G	20AW248020	FRONT PANEL GOLD	20AW248020
387		20AW851310	USER GUIDE	20AW851310

修理の際は、必ず取扱説明書を準備し操作方法を確認の上作業を行ってください。

marantz®

PM7200

20AW855010 MIT
First Issue 2002.07

Service Manual

PM7000 /N1B, /N1G, /U1B
PM8000 /N1B, /N1G, /F1B, /F1N
Integrated amplifier

PM7000/8000

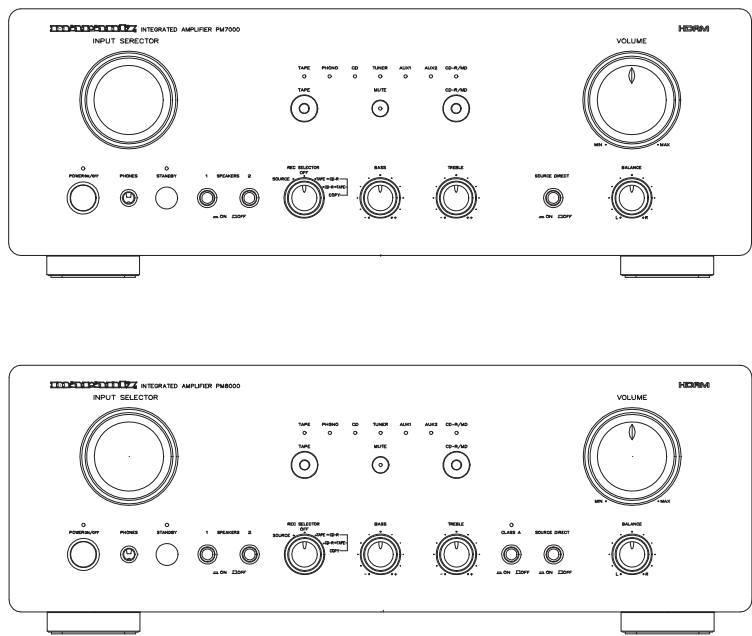

TABLE OF CONTENTS

SECTION	PAGE
1. SPECIFICATIONS	1
2. TEST EQUIPMENT REQUIRED SERVICING	2
3. IC INFORMATIONS	3
4. BLOCK DIAGRAM	5
5. WIRING DIAGRAM	7
6. SCHEMATIC DIAGRAM AND PARTS LOCATION (PARTS SIDE)	9
7. EXPLODED VIEW AND PARTS LIST	33
8. IDLING CURRENT AND DC OFFSET VOLTAGE ALIGNMENT	34
9. ELECTRICAL PARTS LIST	35

Please use this service manual with referring to the user guide (D.F.U) without fail.
修理の際は、必ず取扱説明書を準備し操作方法を確認の上作業を行って下さい。

marantz®

- PM7000 / PM8000 -

MARANTZ DESIGN AND SERVICE

Using superior design and selected high grade components, **MARANTZ** company has created the ultimate in stereo sound. Only original **MARANTZ** parts can insure that your **MARANTZ** product will continue to perform to the specifications for which it is famous.

Parts for your **MARANTZ** equipment are generally available to our National Marantz Subsidiary or Agent.

ORDERING PARTS :

Parts can be ordered either by mail or by Fax.. In both cases, the correct part number has to be specified.

The following information must be supplied to eliminate delays in processing your order :

1. Complete address
2. Complete part numbers and quantities required
3. Description of parts
4. Model number for which part is required
5. Way of shipment
6. Signature : any order form or Fax. must be signed, otherwise such part order will be considered as null and void.

USA

MARANTZ AMERICA, INC.
440 MEDINAH ROAD
ROSELLE, ILLINOIS 60172
USA
PHONE : 630 - 307 - 3100
FAX : 630 - 307 - 2687

EUROPE / TRADING

MARANTZ EUROPE B.V.
P.O.BOX 80002, BUILDING SFF2
5600 JB EINDHOVEN
THE NETHERLANDS
PHONE : +31 - 40 - 2732241
FAX : +31 - 40 - 2735578

BRAZIL

MARANTZ BRAZIL
CAIXA POSTAL 21462
CEP 04698-970
SAO PAULO, SP, BRAZIL
PHONE : 0800 - 123123(Discagem Direta Gratuita)
FAX : +55 11 534. 8988

PROFESSIONAL AMERICAS

SUPERSCOPE TECHNOLOGIES, INC.
MARANTZ PROFESSIONAL PRODUCTS
2640 WHITE OAK CIRCLE, SUITE A
AURORA, ILLINOIS 60504 USA
PHONE : 630 - 820 - 4800
FAX : 630 - 820 - 8103

CANADA

LENBROOK INDUSTRIES LIMITED
633 GRANITE COURT,
PICKERING, ONTARIO L1W 3K1
CANADA
PHONE : 905 - 831 - 6333
FAX : 905 - 831 - 6936

AUSTRALIA

JAMO AUSTRALIA PTY LTD
1 EXPO COURT, P.O. BOX 350
MT. WAVERLEY VIC 3149
AUSTRALIA
PHONE : +61 - 3 - 9543 - 1522
FAX : +61 - 3 - 9543 - 3677

THAILAND

MRZ STANDARD CO.,LTD
746 - 754 MAHACHAI ROAD.,
WANGBURAPAPIROM, PHRANAKORN,
BANGKOK, 10200 THAILAND
PHONE : +66 - 2 - 222 9181
FAX : +66 - 2 - 224 6795

SINGAPORE

WO KEE HONG (S) PTE LTD
WO KEE HONG CENTRE
NO.23, LORONG 8, TOA PAYOH
SINGAPORE 319257
PHONE : +65 2544555
FAX : +65 2502213

TAIWAN

PAI- YUING CO., LTD.
6 TH FL NO, 148 SUNG KIANG ROAD,
TAIPEI, 10429, TAIWAN R.O.C.
PHONE : +886 - 2 - 25221304
FAX : +886 - 2 - 25630415

MALAYSIA

WO KEE HONG ELECTRONICS SDN. BHD.
SUITE 8.1, LEVEL 8, MENARA GENESIS,
NO. 33, JALAN SULTAN ISMAIL,
50250 KUALA LUMPUR, MALAYSIA
PHONE : +60 3 - 2457677
FAX : +60 3 - 2458180

JAPAN *Technical*

MARANTZ JAPAN, INC.
35- 1, 7- CHOME, SAGAMIONO
SAGAMIHARA - SHI, KANAGAWA
JAPAN 228-8505
PHONE : +81 42 748 1013
FAX : +81 42 741 9190

日本マランツ株式会社

本社 〒228-8505
神奈川県相模原市相模大野7-35-1
営業本部 〒150-0022
東京都渋谷区恵比寿南1-11-9

KOREA

MK ENTERPRISES LTD.
ROOM 604/605, ELECTRO-OFFICETEL, 16-58,
3GA, HANGANG-RO, YONGSAN-KU, SEOUL
KOREA
PHONE : +822 - 3232 - 155
FAX : +822 - 3232 - 154

SHOCK, FIRE HAZARD SERVICE TEST :

CAUTION : After servicing this appliance and prior to returning to customer, measure the resistance between either primary AC cord connector pins (with unit NOT connected to AC mains and its Power switch ON), and the face or Front Panel of product and controls and chassis bottom.

Any resistance measurement less than 1 Megohms should cause unit to be repaired or corrected before AC power is applied, and verified before it is return to the user/customer.

Ref. UL Standard No. 1492.

In case of difficulties, do not hesitate to contact the Technical
Department at above mentioned address.

1. SPECIFICATIONS

Power output (class AB operation)

RMS 8ohms (20 Hz - 20 kHz)	95W
DIN 8 ohms	105W
THD at 8 ohms RMS rated output	0.03%
Damping factor	150

Power out put (PM8000 classA operation)

RMS 8 ohms (20 Hz - 20 kHz)	25 W
DIN 8 ohms	28 W
THD at 8 ohms RMS. rated output	0.03%
Damping factor	130

IHF dynamic power (class AB operation)

8 ohms	120 W
--------------	-------

IHF dynamic power (PM8000 class A operation)

8 ohms	35 W
--------------	------

Magnetic cartridge input (MM)

input sensitivity impedance	2.5 mV/47 kOhms
Accuracy of frequency response to IEC RIAA	0.5 dB
Signal to noise ratio	85 dB

Tuner/CD/Aux/Tape inputs

input sensitivity impedance	150 mV/40 kOhms
Signal to noise ratio	109dB
Frequency response	
(-1 dB limits, Source Direct)	10 Hz - 50 kHz
Tone characteristic (100 Hz and 10 kHz)	±8 dB
Channel separation	
(1 kHz/10 kHz, Source direct)	>80 / >70 dB

General

Power Requirements

/N versions	230 V AC,50 Hz
/U versions	120 V AC,60 Hz

Dimensions

Width	440 mm
Height	159 mm
Depth	370.5 mm

Weight

Unit alone	12.3 kg
------------------	---------

Specifications subject to change without prior notice

定格出力(20 Hz - 20 kHz 両チャンネル同時駆動)

クラスAB.....95 W × 2 (8 Ω 負荷)

クラスA.....25 W × 2 (8 Ω 負荷)

全高周波歪率(20 Hz - 20 kHz, 10 W出力時8 Ω負荷)

クラスAB.....0.015%

クラスA.....0.010%

混変調歪率 (SMPTE).....0.015%

出力帯域幅 (8Ω負荷,0.08%歪率).....10 Hz - 80 kHz

周波数特性

(CD,ソースダイレクト).....10 Hz - 50 kHz +0 dB -1 dB

ダンピングファクター (8 Ω負荷,100 Hz - 10 kHz).....130

入力感度/入力インピーダンス

PHONO (MM).....2.5 mV/47 kΩ

HIGH LEVEL 150 mV/40 kΩ |

PHONO最大許容入力 (1 kHz)

(MM) 150 mV |

RIAA偏差 (20 Hz).....-2 dB

(40 Hz - 20 kHz).....±0.5 dB

S/N比 (IHF,Aネットワーク,入力ショート)

PHONO (MM).....85 dB

HIGH LEVEL 109 dB |

トーンコントロール

BASS (100 Hz) ±8 dB |

TREBLE (10 kHz).....±8 dB

電源電圧 AC 100 V, 50 Hz/60 Hz |

消費電力 (電気用品取締法).....160 W

最大外形寸法

幅 440 mm |

高さ 159 mm |

奥行き 370.5 mm |

質量 12.3 kg |

付属品

リモートコントロール送信機(RC8000PM).....1台

本機の規格および外観は改良のため予告なく変更することがあります。

1

2.TEST EQUIPMENT REQUIRED FOR SERVICING

Item	Use
Distortion Analyzer	Distortion measurements
Audio Oscillator	Sinewave and squarewave signal source
AC VTVM	Voltage measurements (AC)
Oscilloscope	Waveform analysis and trouble shooting and ASO alignment
DC VTVM	Voltage measurements (DC)
AC Wattmeter	Monitors primary power to amplifier
Line Voltmeter	Monitors of primary voltage to amplifier
Variable Autotransformer	Adjust level of primary voltage to amplifier
Circuit Tester	Trouble shooting
Shorting Plug	Shorts amplifier input to eliminate noise pickup

項 目	使 用 方 法
歪 率 計	歪の測定
低 周 波 発 振 器	正弦波および矩形波の信号源
A C V T V M	交流電圧の測定
オ シ ロ ス コ ー プ	波計分析、トラブルシューティングおよびASOの調整
D C V T V M	直流電圧の測定
交流ワットメーター	アンプの一次側消費電力のモニター
電 源 電 圧 計	アンプの一次側電圧のモニター
ス ラ イ ダ ッ ク	アンプの一次側電圧の調整
テ ス タ ー	トラブルシューティング
ショート用プラグ	雑音を拾わないようにアンプ入力を短絡する

3. IC INFORMATIONS

MICROPROCESSOR TMP47C200BM BLOCK DIAGRAM

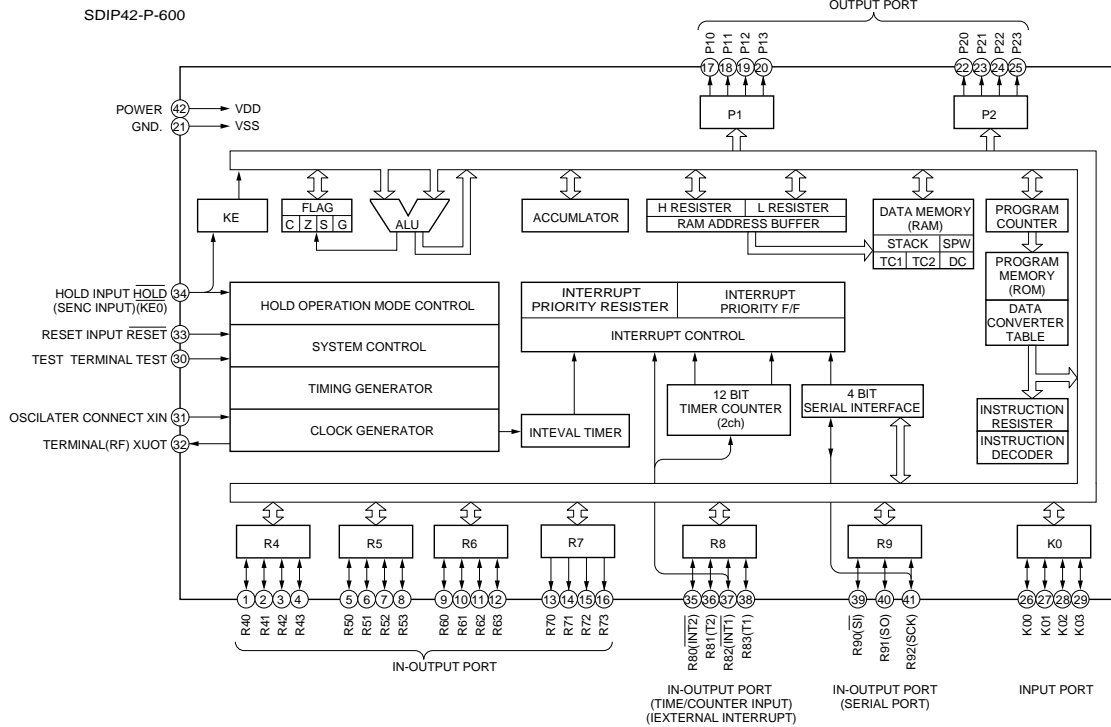

PIN no.	PORT NAME	ACT	FUNCTION
1	R40	MMUT	H MANUAL MUTE SIGNAL MUTE
2	R41	FMUT	L SIGNAL(SOURCE/MONITOR SWITCH)
3	R42	VOUP	L MOTOR DRIVE VOLUME UP
4	R43	VODW	L MOTOR DRIVE VOLUME DOWN
5	R50	T3K	L MONITOR INPUT SWITCH (TAPE3)
6	R51	T2K	L MONITOR INPUT SWITCH (TAPE2)
7	R52	T1K	L MONITOR INPUT SWITCH (TAPE1)
8	R53	AX2K	L SOURCE INPUT SWITCH (AUX2)
9	R60	AX1K	L SOURCE INPUT SWITCH (AUX1)
10	R61	TUNK	L SOURCE INPUT SWITCH (TUNER)
11	R62	CDK	L SOURCE INPUT SWITCH (CD)
12	R63	PHOK	L SOURCE INPUT SWITCH (PHONO)
13	R70	LSTB	L LED INDICATOR STAND BY DISPLAY
14	R71	LMUT	L LED INDICATOR MUTE DISPLAY
15	R72	LPRO	L LED INDICATOR PROCESSOR DISPLAY
16	R73	LTP3	L LED INDICATOR TAPE3 DISPLAY
17	P10	LTP2	L LED INDICATOR TAPE2 DISPLAY
18	P11	LTP1	L LED INDICATOR TAPE1 DISPLAY
19	P12	LSOU	L LED INDICATOR SOURCE DISPLAY
20	P13	LAX2	L LED INDICATOR AUX2 DISPLAY
21	VSS		GND.
22	P20	LAX1	L LED INDICATOR AUX1 DISPLAY
23	P21	LTUN	L LED INDICATOR TUNER DISPLAY
24	P22	LECD	L LED INDICATOR CD DISPLAY
25	P23	LPHO	L LED INDICATOR PHONO DISPLAY
26	K00	1RS	L SOURCE INPUT SWITCH(ROTARY ENCODER) bit1
27	K01	2RS	L SOURCE INPUT SWITCH(ROTARY ENCODER) bit2
28	K02	PRK	L PROCESSOR IN-OUT SWITCH
29	K03	MUK	L MANUAL MUTE
30	TEST		NOT USED (GND)
31	XIN		CLOCK 4.00 MHz (IN)
32	XOUT		CLOCK 4.00 MHz (OUT)
33	RESET	RES	L SYSTEM RESET
34	HOLD	PDW	L POWER DOWN CHECK
35	R80	RXRC	L REMOTE CONTROL INPUT (RC-5)
36	R81	EN1	MODEL SELECT 1
37	R82	EN2	MODEL SELECT 2
38	R83	EN3	MODEL SELECT 3
39	R90	TXRC	L SERIAL DATA(RC-5 REMOTE CONTROL)
40	R91	ENTX	L ENABLE (REMOTE CONTROL)
41	R92	RELY	L STAND-BY RELAY CONTROL
42	VDD		POWER SUPPLY

MICROPROCESSOR TMP47C200BM

Position NO.7401

SDIP42-P-600

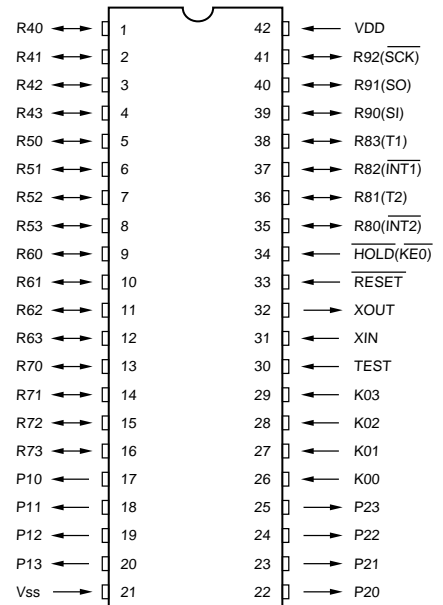

TA7317P (Position NO.7290)

TA7317P

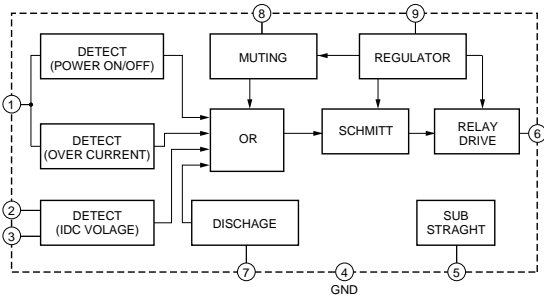
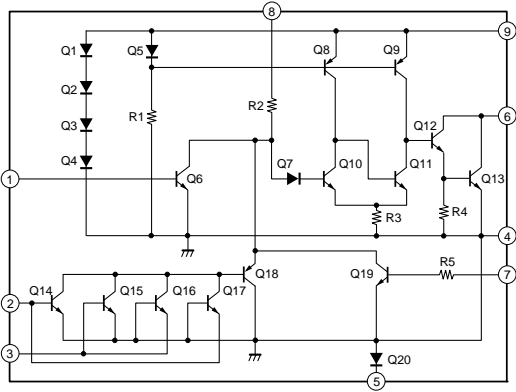
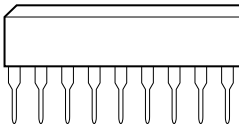

LB1641(Position NO.7402)

LB1641

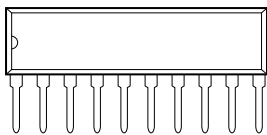

LB1641

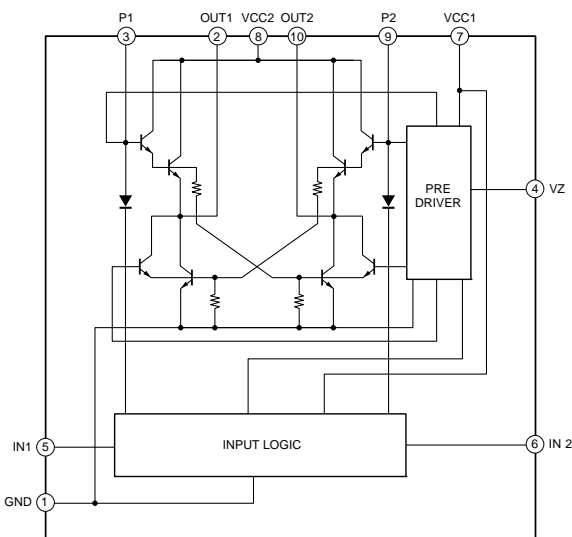

NJM2068 (Position NO.7501,7502,7503)

NJM2068

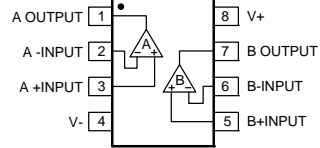

NJM2068

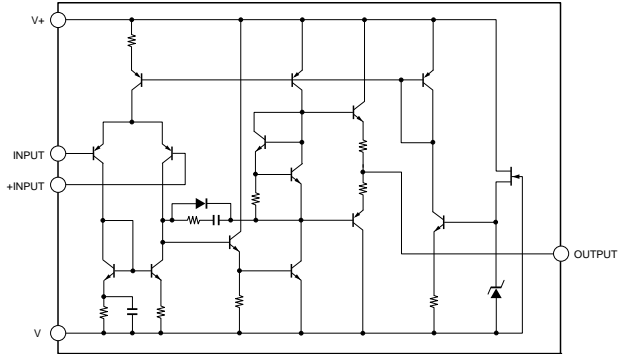

PC817 (Position NO.7269,7270)

PC817

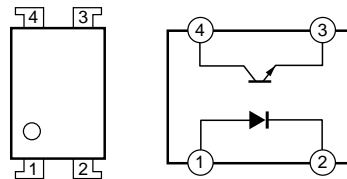

NJM2114(Position NO.7555,7655)

NJM2114

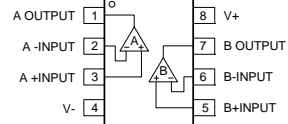

NJM2114

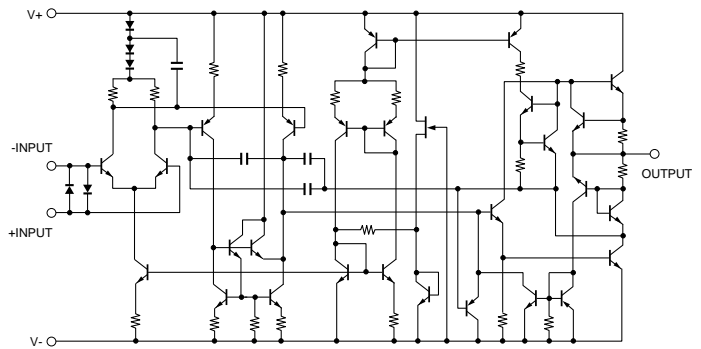

4. BLOCK DIAGRAM

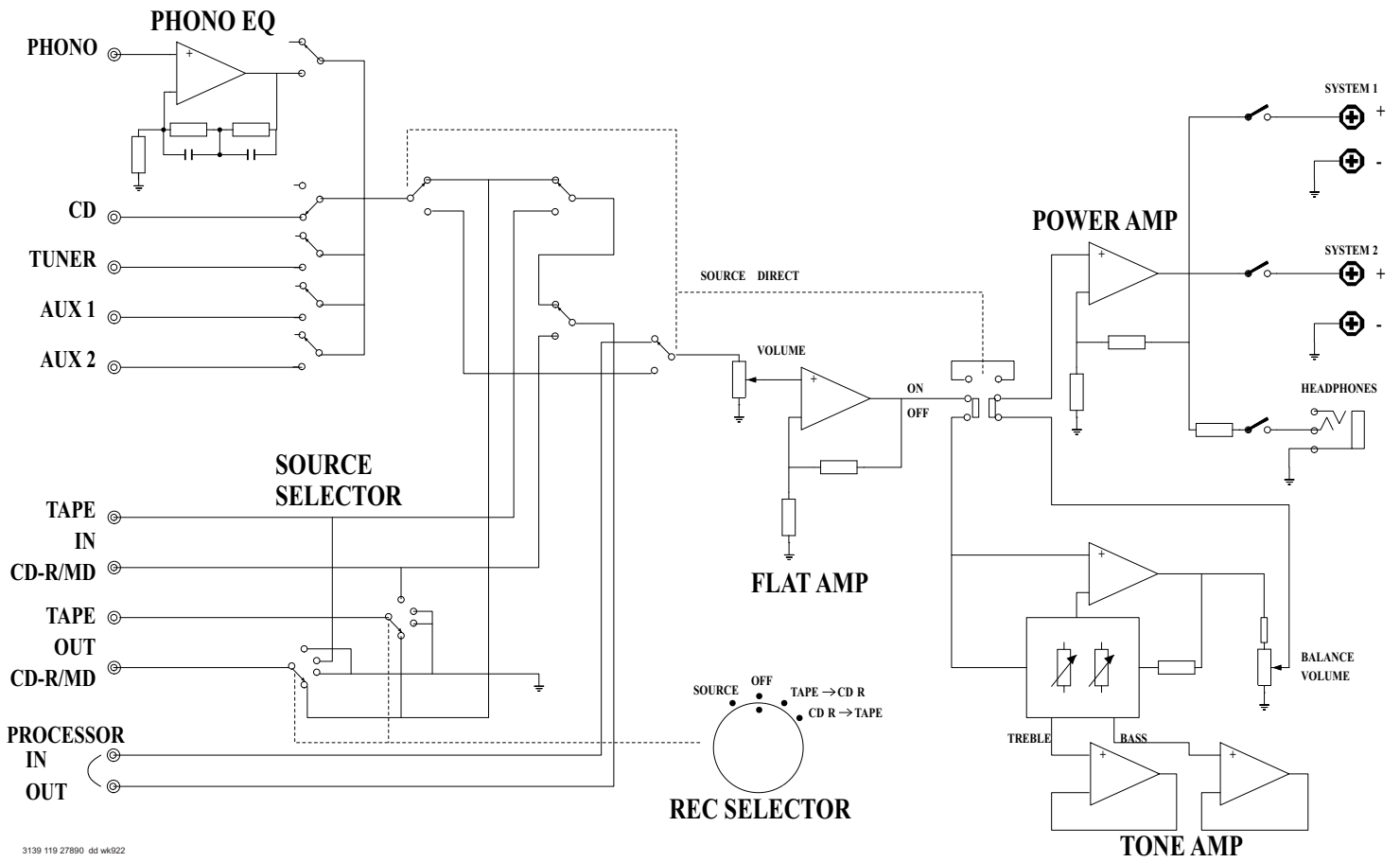

3139 119 27890 dd wk922

5. WIRING DIAGRAM

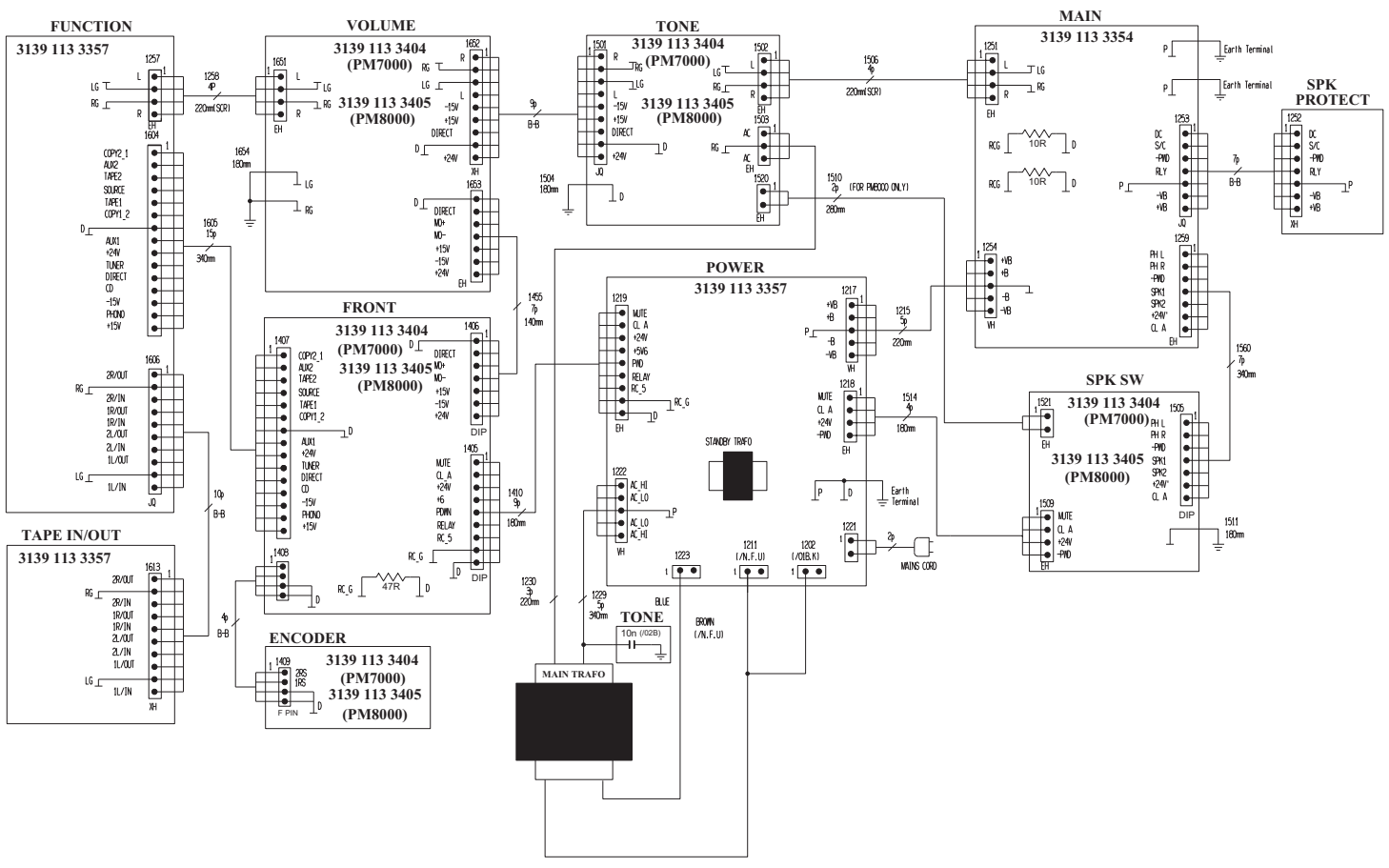

6. SCHEMATIC DIAGRAM AND PARTS LOCATION (PARTS SIDE)
 FUNCTION & TAPE IN/OUT CIRCUIT

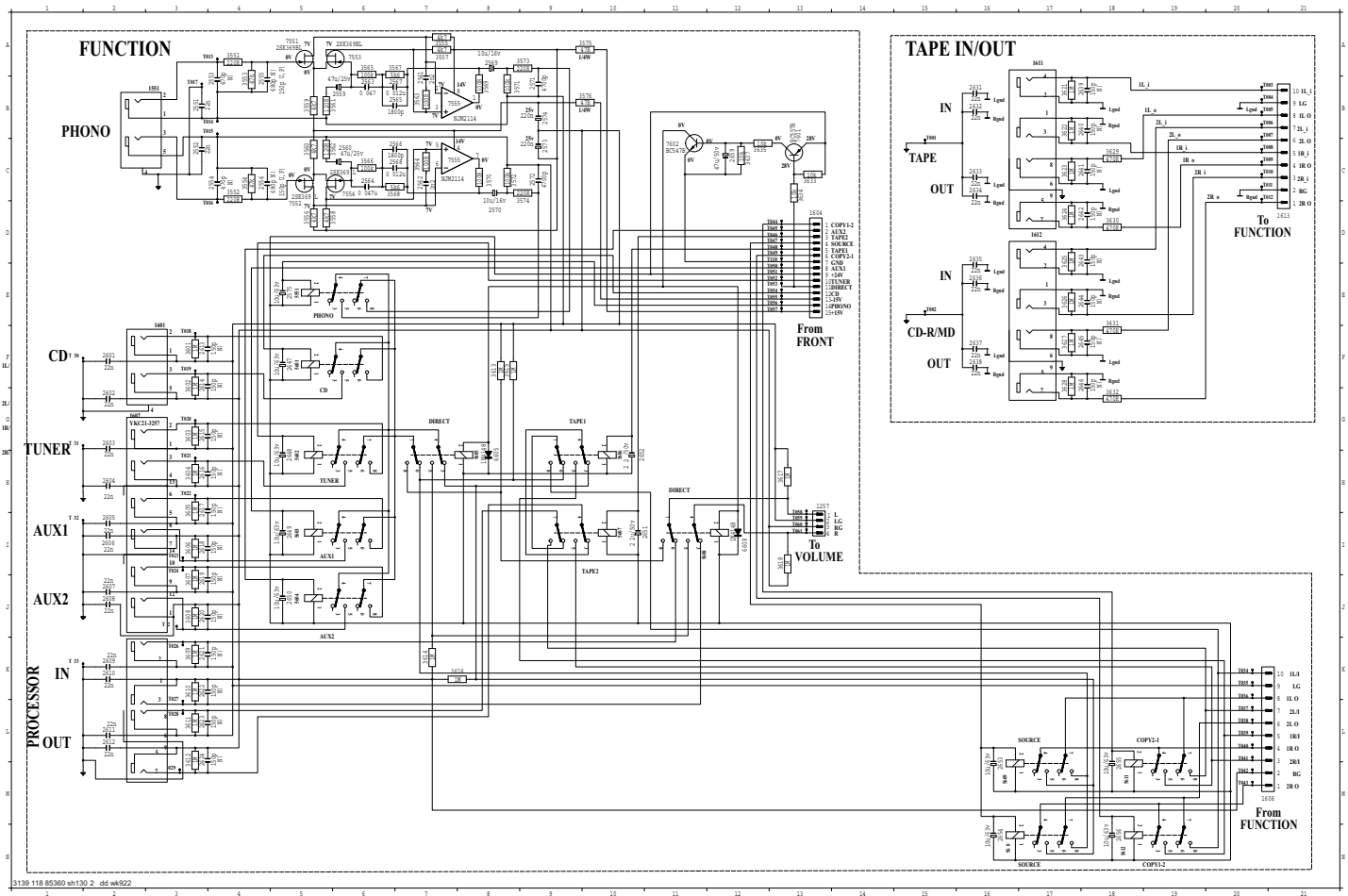

POWER CIRCUIT

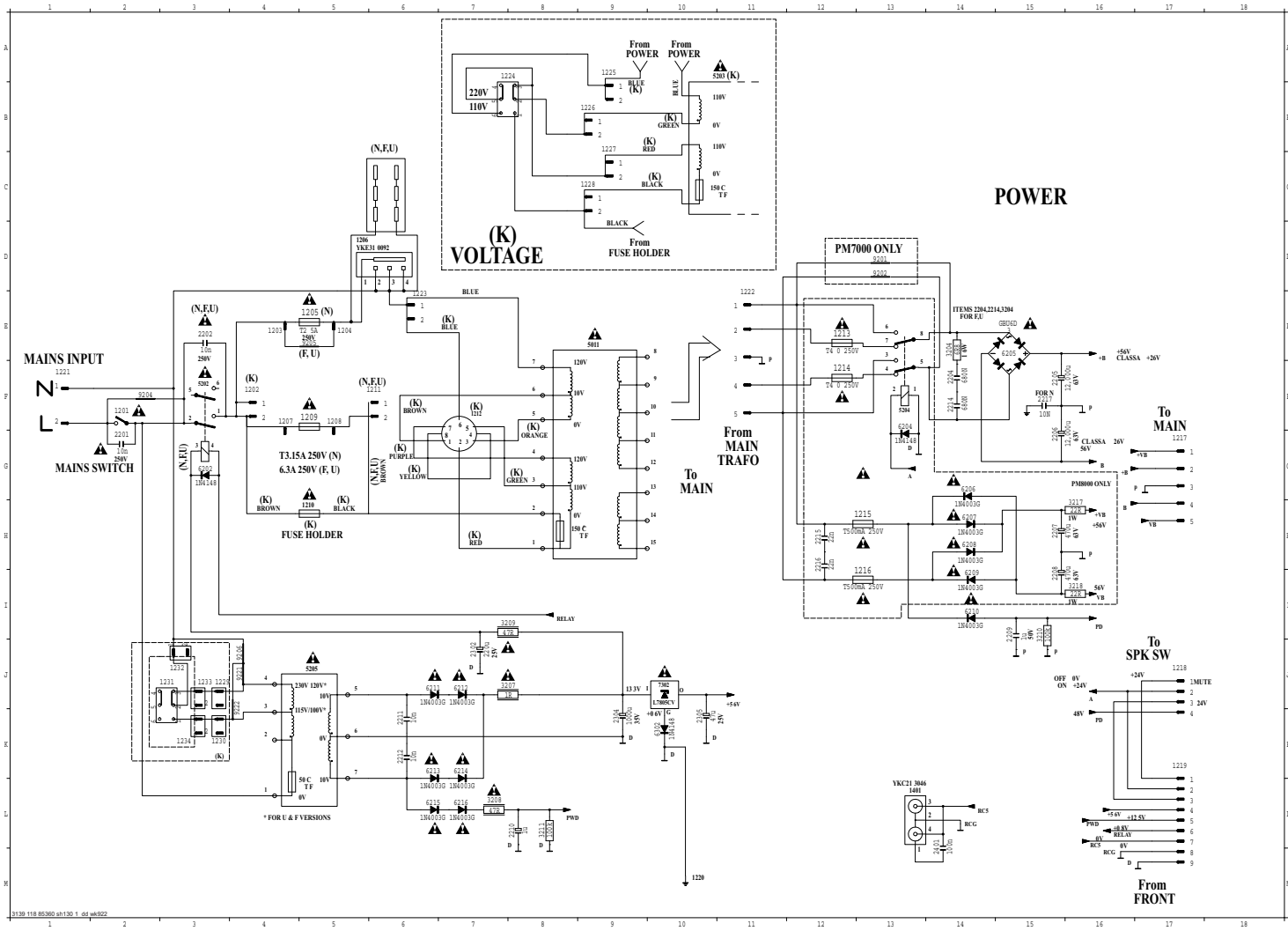

FRONT CIRCUIT

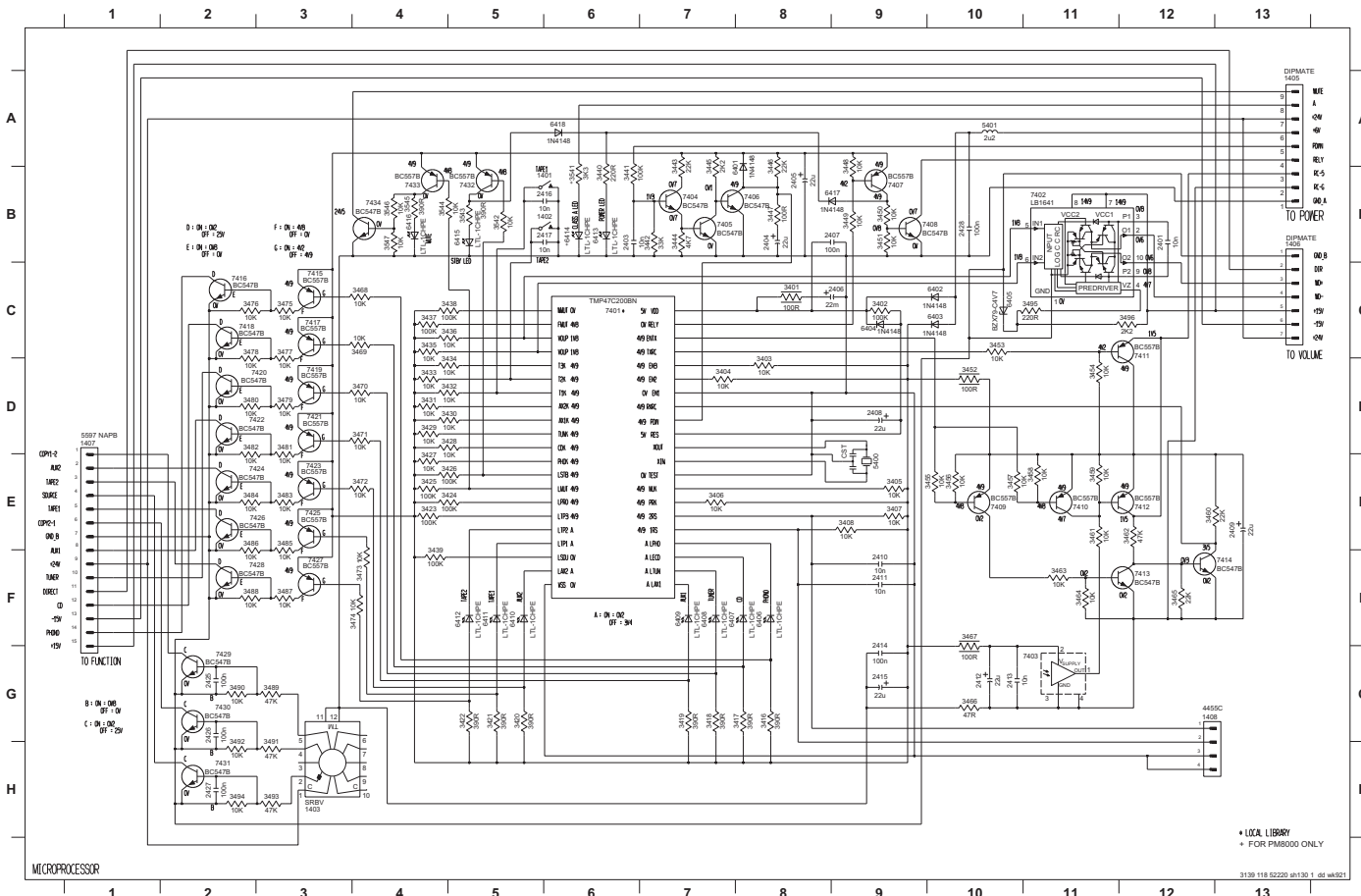

- 1401 BE 3487 F3
- 1402 BE 3488 F2
- 1403 A1 3489 G3
- 1404 A1 3490 G2
- 1405 B1 3491 H3
- 1406 B1 3492 H2
- 1407 G1 3493 H3
- 1408 G1 3494 H2
- 1409 G1 3495 H3
- 1410 H1 3496 H2
- 1411 H1 3497 H3
- 1412 H1 3498 H2
- 1413 H1 3499 H3
- 1414 H1 3500 H2
- 1415 H1 3501 H3
- 1416 H1 3502 H2
- 1417 H1 3503 H3
- 1418 H1 3504 H2
- 1419 H1 3505 H3
- 1420 H1 3506 H2
- 1421 H1 3507 H3
- 1422 H1 3508 H2
- 1423 H1 3509 H3
- 1424 H1 3510 H2
- 1425 H1 3511 H3
- 1426 H1 3512 H2
- 1427 H1 3513 H3
- 1428 H1 3514 H2
- 1429 H1 3515 H3
- 1430 H1 3516 H2
- 1431 H1 3517 H3
- 1432 H1 3518 H2
- 1433 H1 3519 H3
- 1434 H1 3520 H2
- 1435 H1 3521 H3
- 1436 H1 3522 H2
- 1437 H1 3523 H3
- 1438 H1 3524 H2
- 1439 H1 3525 H3
- 1440 H1 3526 H2
- 1441 H1 3527 H3
- 1442 H1 3528 H2
- 1443 H1 3529 H3
- 1444 H1 3530 H2
- 1445 H1 3531 H3
- 1446 H1 3532 H2
- 1447 H1 3533 H3
- 1448 H1 3534 H2
- 1449 H1 3535 H3
- 1450 H1 3536 H2
- 1451 H1 3537 H3
- 1452 H1 3538 H2
- 1453 H1 3539 H3
- 1454 H1 3540 H2
- 1455 H1 3541 H3
- 1456 H1 3542 H2
- 1457 H1 3543 H3
- 1458 H1 3544 H2
- 1459 H1 3545 H3
- 1460 H1 3546 H2
- 1461 H1 3547 H3
- 1462 H1 3548 H2
- 1463 H1 3549 H3
- 1464 H1 3550 H2
- 1465 H1 3551 H3
- 1466 H1 3552 H2
- 1467 H1 3553 H3
- 1468 H1 3554 H2
- 1469 H1 3555 H3
- 1470 H1 3556 H2
- 1471 H1 3557 H3
- 1472 H1 3558 H2
- 1473 H1 3559 H3
- 1474 H1 3560 H2
- 1475 H1 3561 H3
- 1476 H1 3562 H2
- 1477 H1 3563 H3
- 1478 H1 3564 H2
- 1479 H1 3565 H3
- 1480 H1 3566 H2
- 1481 H1 3567 H3
- 1482 H1 3568 H2
- 1483 H1 3569 H3
- 1484 H1 3570 H2
- 1485 H1 3571 H3
- 1486 H1 3572 H2
- 1487 H1 3573 H3
- 1488 H1 3574 H2
- 1489 H1 3575 H3
- 1490 H1 3576 H2
- 1491 H1 3577 H3
- 1492 H1 3578 H2
- 1493 H1 3579 H3
- 1494 H1 3580 H2
- 1495 H1 3581 H3
- 1496 H1 3582 H2
- 1497 H1 3583 H3
- 1498 H1 3584 H2
- 1499 H1 3585 H3
- 1500 H1 3586 H2
- 1501 H1 3587 H3
- 1502 H1 3588 H2
- 1503 H1 3589 H3
- 1504 H1 3590 H2
- 1505 H1 3591 H3
- 1506 H1 3592 H2
- 1507 H1 3593 H3
- 1508 H1 3594 H2
- 1509 H1 3595 H3
- 1510 H1 3596 H2
- 1511 H1 3597 H3
- 1512 H1 3598 H2
- 1513 H1 3599 H3
- 1514 H1 3600 H2
- 1515 H1 3601 H3
- 1516 H1 3602 H2
- 1517 H1 3603 H3
- 1518 H1 3604 H2
- 1519 H1 3605 H3
- 1520 H1 3606 H2
- 1521 H1 3607 H3
- 1522 H1 3608 H2
- 1523 H1 3609 H3
- 1524 H1 3610 H2
- 1525 H1 3611 H3
- 1526 H1 3612 H2
- 1527 H1 3613 H3
- 1528 H1 3614 H2
- 1529 H1 3615 H3
- 1530 H1 3616 H2
- 1531 H1 3617 H3
- 1532 H1 3618 H2
- 1533 H1 3619 H3
- 1534 H1 3620 H2
- 1535 H1 3621 H3
- 1536 H1 3622 H2
- 1537 H1 3623 H3
- 1538 H1 3624 H2
- 1539 H1 3625 H3
- 1540 H1 3626 H2
- 1541 H1 3627 H3
- 1542 H1 3628 H2
- 1543 H1 3629 H3
- 1544 H1 3630 H2
- 1545 H1 3631 H3
- 1546 H1 3632 H2
- 1547 H1 3633 H3
- 1548 H1 3634 H2
- 1549 H1 3635 H3
- 1550 H1 3636 H2
- 1551 H1 3637 H3
- 1552 H1 3638 H2
- 1553 H1 3639 H3
- 1554 H1 3640 H2
- 1555 H1 3641 H3
- 1556 H1 3642 H2
- 1557 H1 3643 H3
- 1558 H1 3644 H2
- 1559 H1 3645 H3
- 1560 H1 3646 H2
- 1561 H1 3647 H3
- 1562 H1 3648 H2
- 1563 H1 3649 H3
- 1564 H1 3650 H2
- 1565 H1 3651 H3
- 1566 H1 3652 H2
- 1567 H1 3653 H3
- 1568 H1 3654 H2
- 1569 H1 3655 H3
- 1570 H1 3656 H2
- 1571 H1 3657 H3
- 1572 H1 3658 H2
- 1573 H1 3659 H3
- 1574 H1 3660 H2
- 1575 H1 3661 H3
- 1576 H1 3662 H2
- 1577 H1 3663 H3
- 1578 H1 3664 H2
- 1579 H1 3665 H3
- 1580 H1 3666 H2
- 1581 H1 3667 H3
- 1582 H1 3668 H2
- 1583 H1 3669 H3
- 1584 H1 3670 H2
- 1585 H1 3671 H3
- 1586 H1 3672 H2
- 1587 H1 3673 H3
- 1588 H1 3674 H2
- 1589 H1 3675 H3
- 1590 H1 3676 H2
- 1591 H1 3677 H3
- 1592 H1 3678 H2
- 1593 H1 3679 H3
- 1594 H1 3680 H2
- 1595 H1 3681 H3
- 1596 H1 3682 H2
- 1597 H1 3683 H3
- 1598 H1 3684 H2
- 1599 H1 3685 H3
- 1600 H1 3686 H2
- 1601 H1 3687 H3
- 1602 H1 3688 H2
- 1603 H1 3689 H3
- 1604 H1 3690 H2
- 1605 H1 3691 H3
- 1606 H1 3692 H2
- 1607 H1 3693 H3
- 1608 H1 3694 H2
- 1609 H1 3695 H3
- 1610 H1 3696 H2
- 1611 H1 3697 H3
- 1612 H1 3698 H2
- 1613 H1 3699 H3
- 1614 H1 3700 H2
- 1615 H1 3701 H3
- 1616 H1 3702 H2
- 1617 H1 3703 H3
- 1618 H1 3704 H2
- 1619 H1 3705 H3
- 1620 H1 3706 H2
- 1621 H1 3707 H3
- 1622 H1 3708 H2
- 1623 H1 3709 H3
- 1624 H1 3710 H2
- 1625 H1 3711 H3
- 1626 H1 3712 H2
- 1627 H1 3713 H3
- 1628 H1 3714 H2
- 1629 H1 3715 H3
- 1630 H1 3716 H2
- 1631 H1 3717 H3
- 1632 H1 3718 H2
- 1633 H1 3719 H3
- 1634 H1 3720 H2
- 1635 H1 3721 H3
- 1636 H1

MAIN CIRCUIT

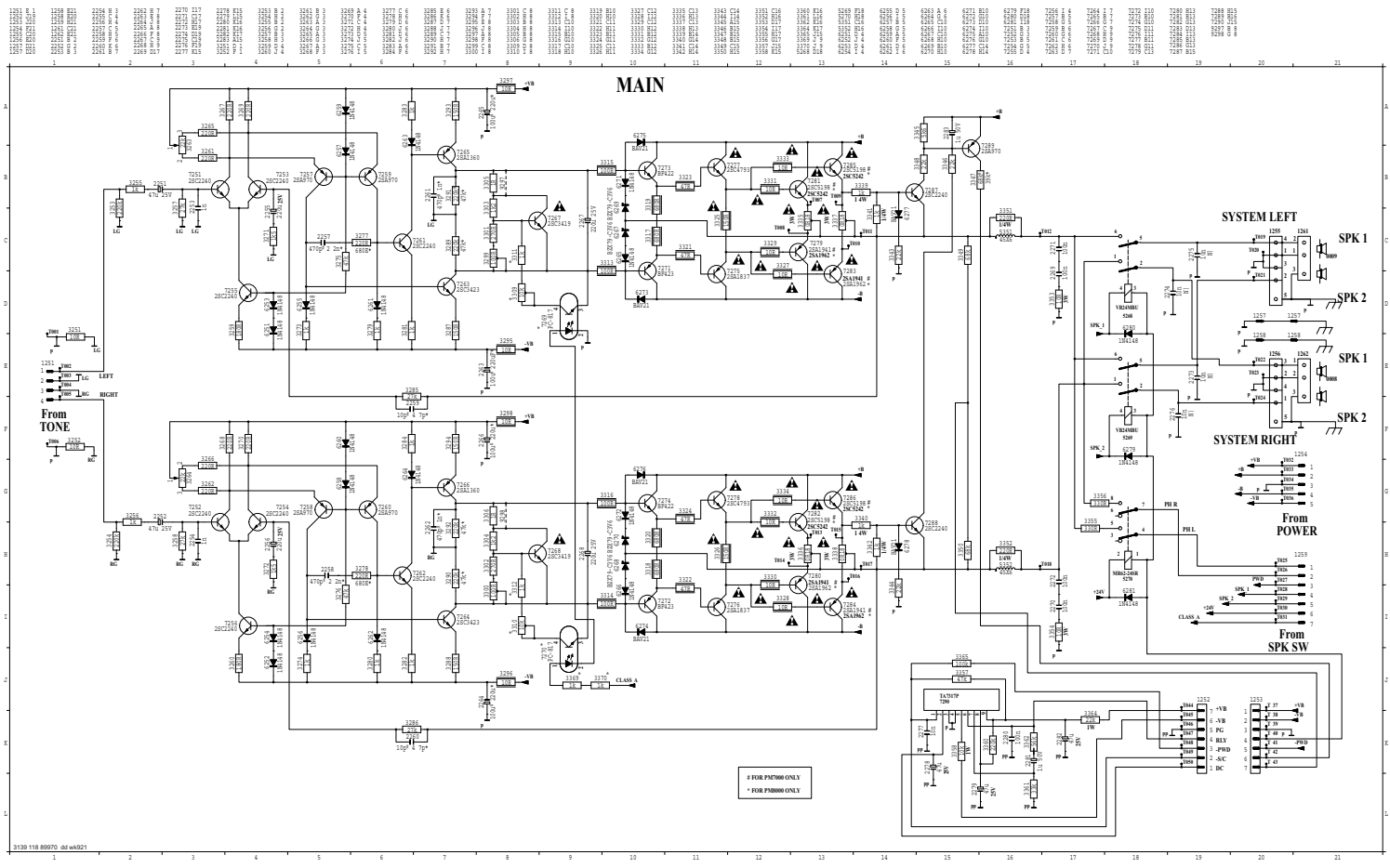

TO NE CIRCUIT

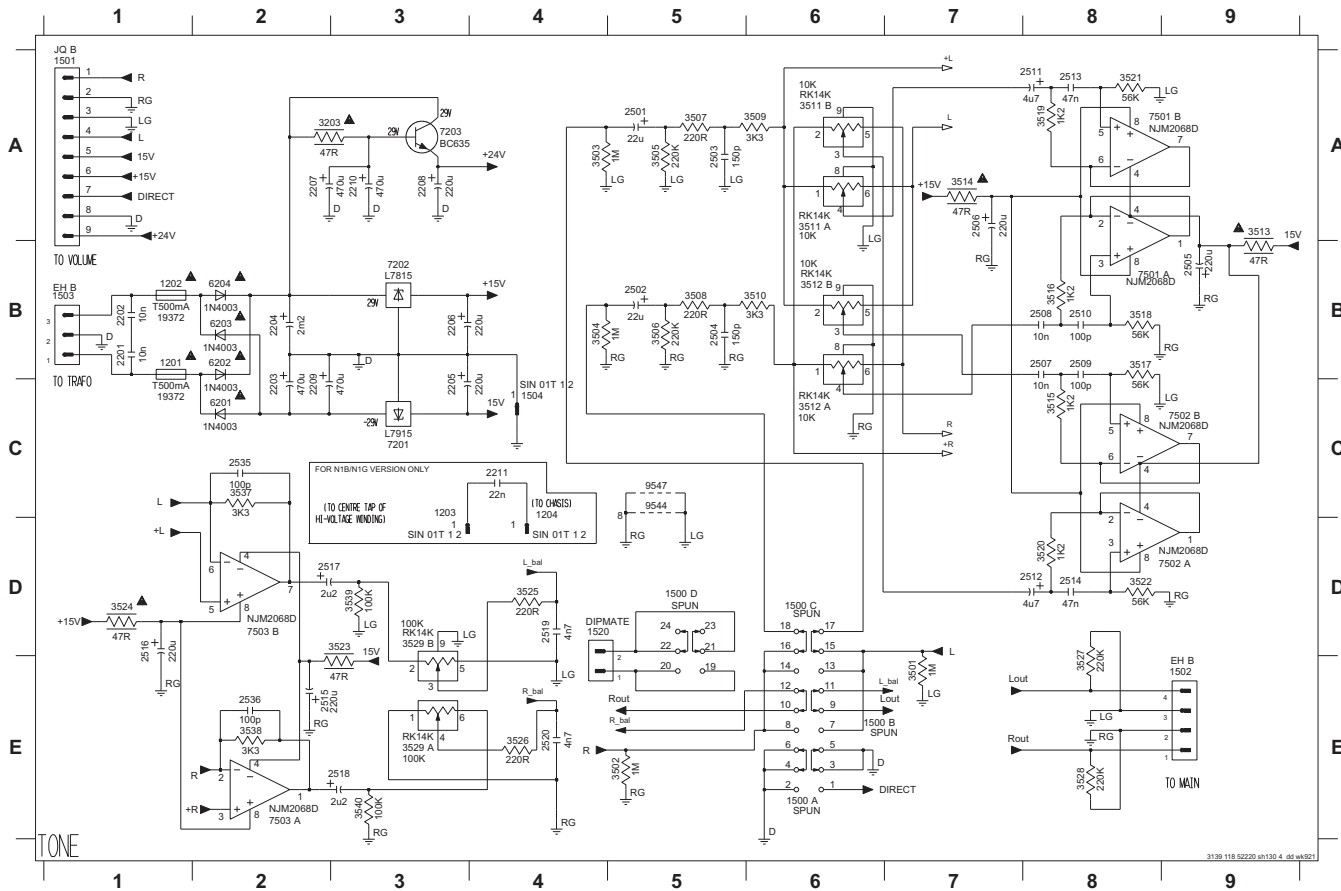

1201 B1	3524 D1
1202 B1	3525 D4
1203 C3	3526 E4
1204 C4	3527 E8
1500 A E6	3528 E8
1500 B E7	3529 A E3
1500 C D6	3529 B D3
1500 D D5	3537 C2
1501 A1	3538 E2
1501 A1	3539 D3
1503 B1	3540 E3
1504 C4	6201 C2
1520 D5	6202 B2
2201 B1	6203 B2
2202 B1	6204 B2
2203 C2	7201 C3
2204 B2	7202 B3
2205 C3	7203 A3
2206 B3	7501 A B8
2207 A2	7501 B A8
2208 A3	7502 A D8
2209 C2	7502 B C9
2210 A3	7503 A E2
2211 C4	7503 B D2
2501 A5	9544 C5
2502 B5	9545 C5
2503 A5	
2504 B5	
2505 B9	
2506 A7	
2507 B8	
2508 B8	
2509 B8	
2510 B8	
2511 A8	
2512 D8	
2513 A8	
2514 D8	
2515 E2	
2516 D1	
2517 D2	
2518 E3	
2519 D4	
2520 E4	
2535 C2	
2536 E2	
3203 A2	
3501 E7	
3502 E5	
3503 A4	
3504 B4	
3505 A5	
3506 B5	
3507 A5	
3508 B5	
3509 A6	
3510 B6	
3511 A A6	
3512 A C6	
3512 B B6	
3513 A9	
3514 A7	
3515 C8	
3516 B8	
3517 B8	
3518 B8	
3519 A8	
3520 D8	
3521 A8	
3522 D8	
3523 D3	

SPK SW CIRCUIT

1505 A1	1509 C4	1521 E4	3530 E2	3533 A2	6529 D1	9508 C2
1507 A B2	1510 A3	2533 A2	3531 E2	3534 A2	7529 D2	
1507 B B3	1511 E2	2534 A2	3532 D3	3535 D2	7530 D2	

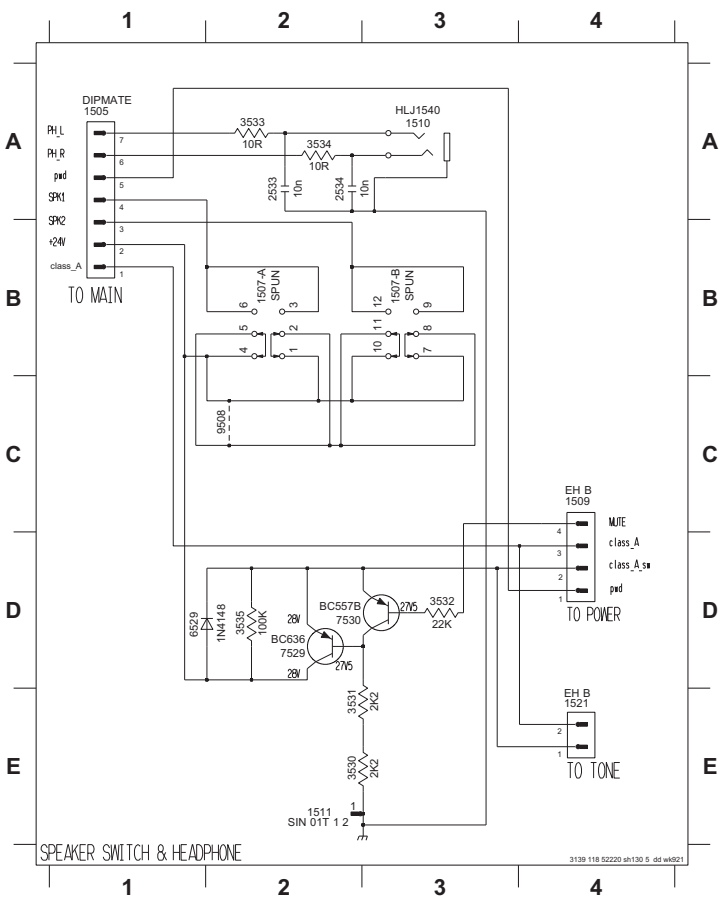

ENCODER CIRCUIT

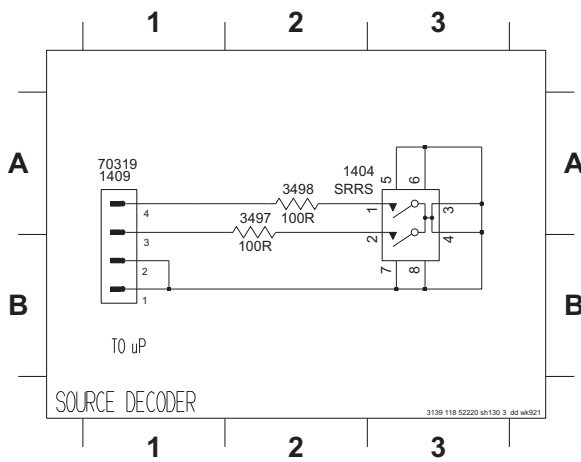

1404 A3
1409 A1
3497 A2
3498 A2

ENCODER BOARD

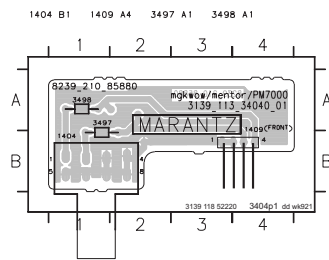

VOLUME CONTROL CIRCUIT (PM7000)

1651 B1	1655 D1	2654 D3	2658 C4	2662 D6	2666 C6	2670 C4	3653 A2	3657 B3	3661 A3	3665 B4	3669 B5	3673 B6	3681 A C2	7651 B3	7655 A D5
1652 B8	2651 A1	2655 B3	2659 A4	2663 B7	2667 A1	2671 A1	3654 D2	3658 C3	3662 D3	3666 D4	3670 D5	3674 D6	3681 B C2	7652 D3	7655 B B5
1653 A8	2652 D2	2656 D3	2660 D4	2664 D7	2668 A2	3651 B2	3655 B3	3659 A3	3663 B4	3667 C4	3671 B6	3675 A7	3681 C C2	7653 B4	
1654 D1	2653 B3	2657 B4	2661 B6	2665 C6	2669 B4	3652 D2	3656 D3	3660 D3	3664 D4	3668 C4	3672 D6	3676 A7	3681 D B1	7654 D4	

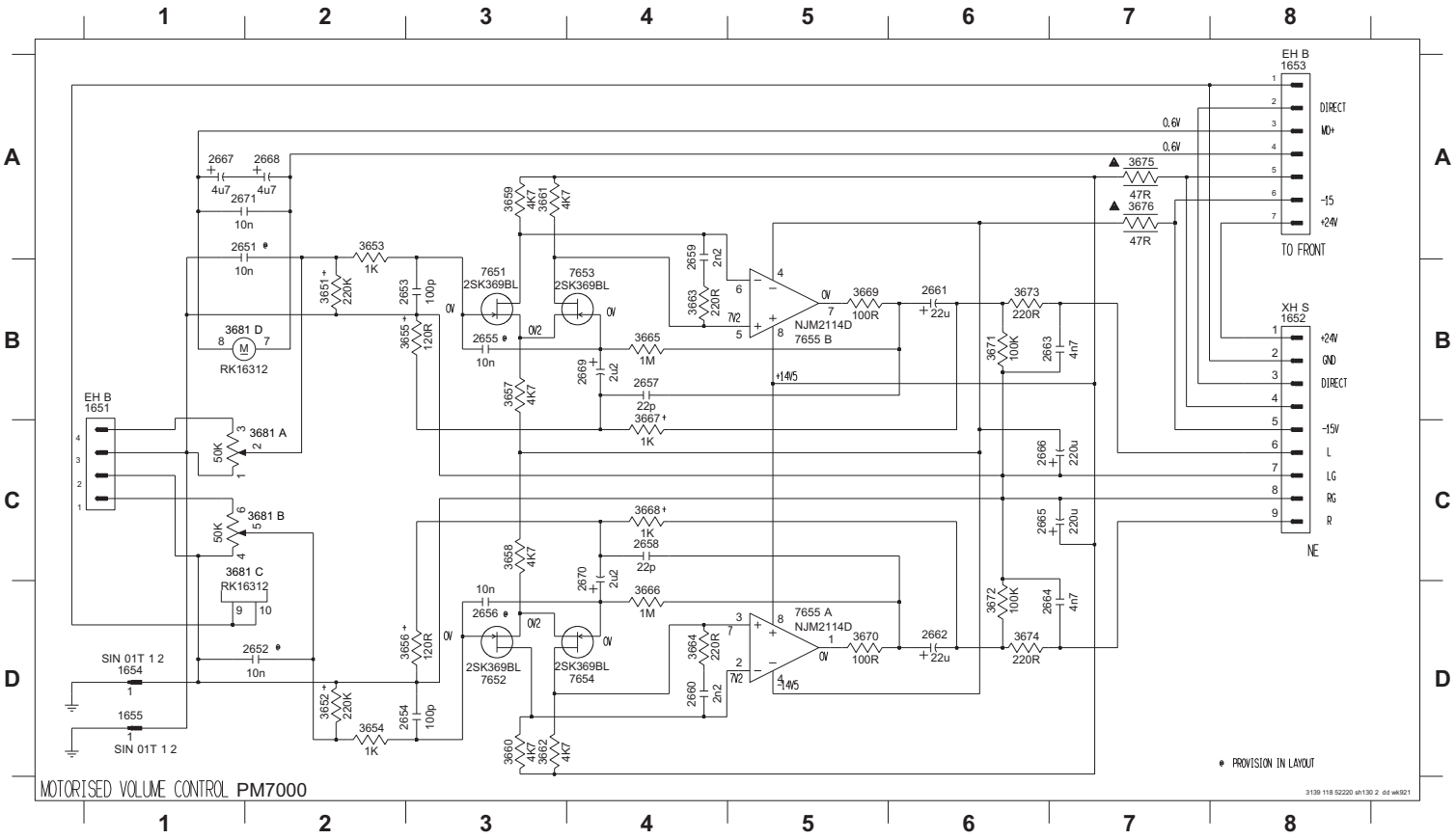

TONE BOARD (PM7000)

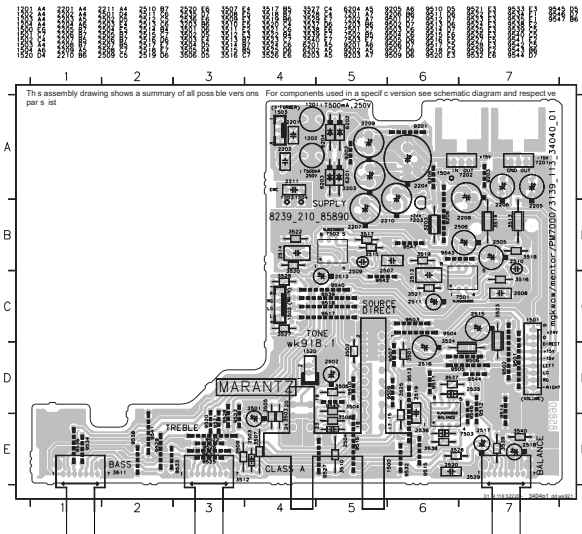

TONE BOARD (PM8000)

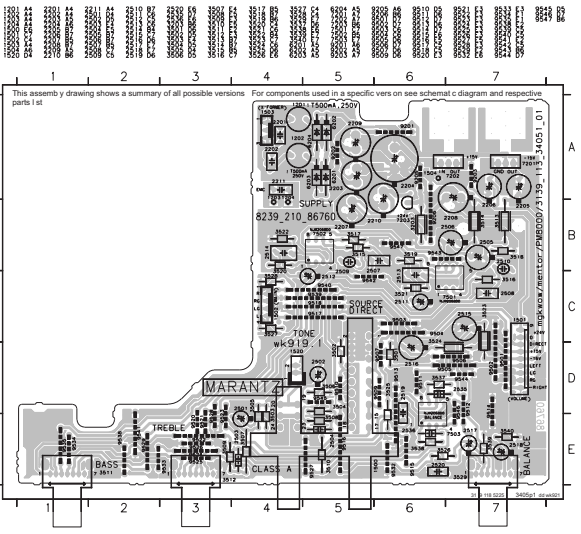

FRONT BOARD

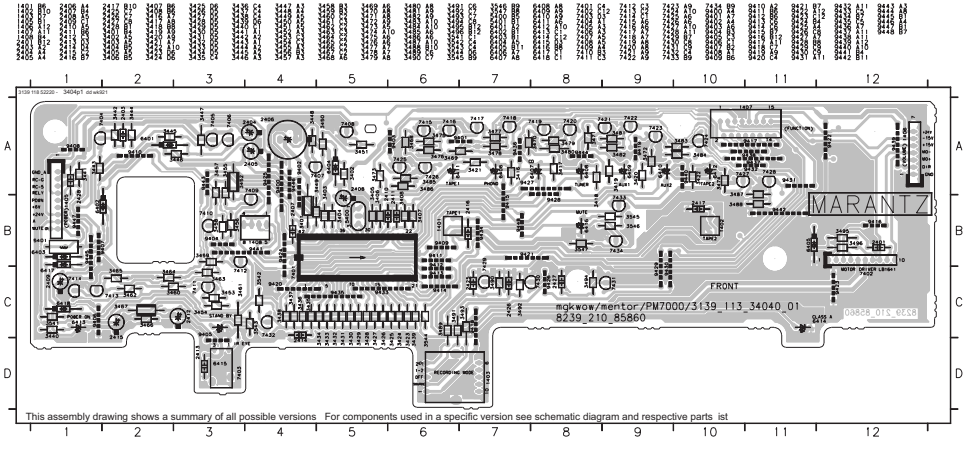

SPK SW BOARD

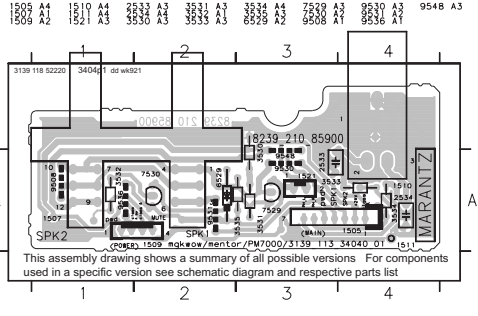

VOLUME BOARD (PM7000)

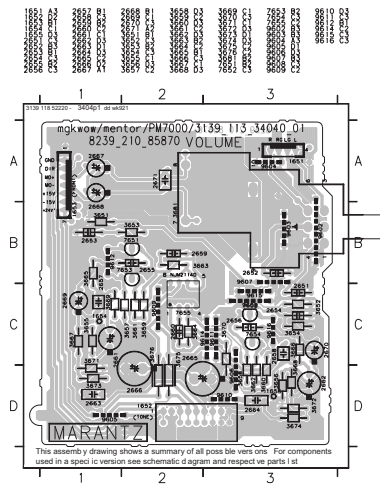

VOLUME BOARD (PM8000)

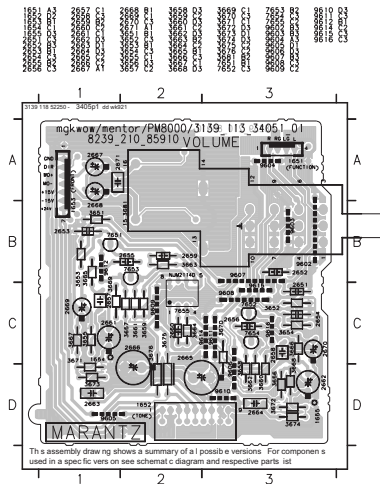

MAIN & SP PROTECT BOARD

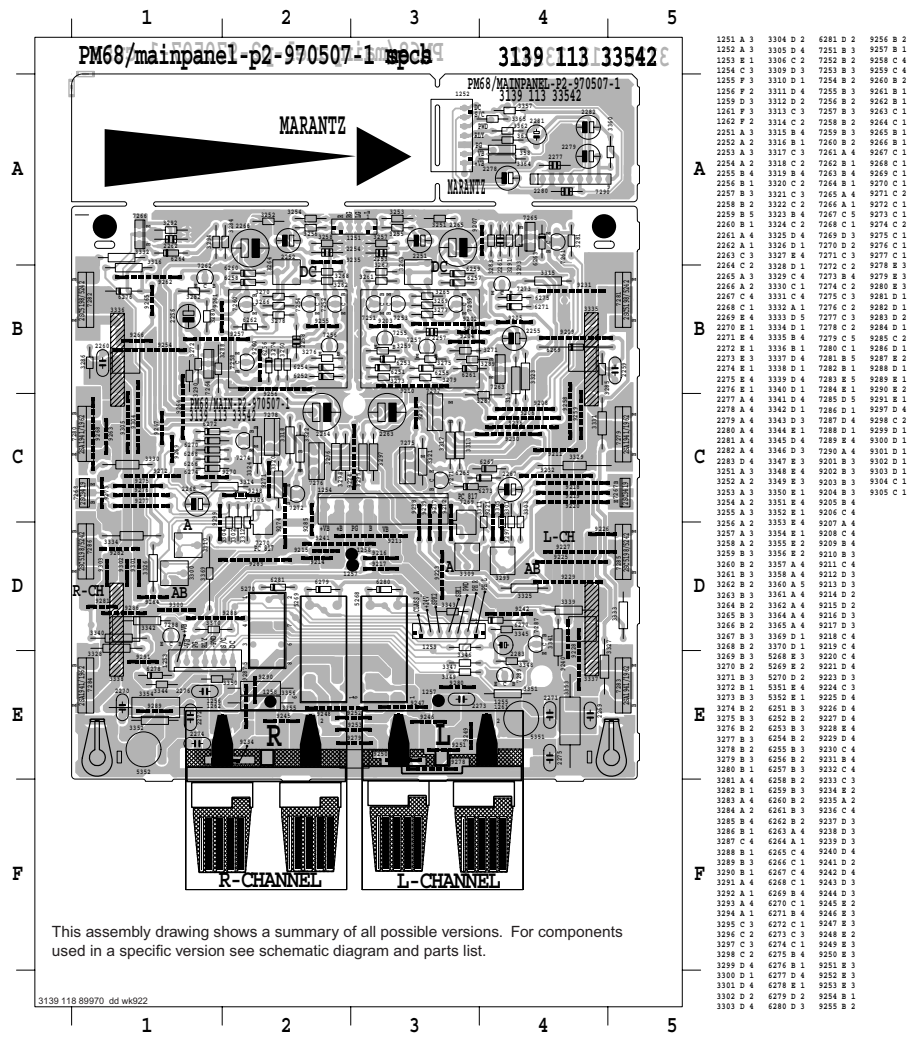

POS. NO	VERS. COLOR	PART NO. (PCS)	DESCRIPTION
200	PM7000 BLK	3139 117 88070	FRONT PANEL BLACK
200	PM8000 BLK	3139 117 88080	FRONT PANEL BLACK
200	PM7000 GLD	3139 117 88050	FRONT PANEL GOLD
200	PM8000 GLD	3139 117 88060	FRONT PANEL GOLD
201		4822 454 11825	PLATE, INDICATION
202	BLK	3139 114 66790	WINDOW IR BLACK
202	GLD	3139 114 66800	WINDOW IR GOLD
203		3139 114 66920	LIGHT GUIDE POWER/CLASS
204		3139 114 66900	LIGHT GUIDE MUTE
206		3139 114 66910	LIGHT GUIDE SOURCE
207	BLK	3139 114 66940	CABINET, FRONT BLACK
207	GLD	3139 117 88580	CABINET, FRONT GOLD
210	BLK	3139 114 66930	BUTTON TAPE BLACK
210	GLD	3139 117 88610	BUTTON TAPE GOLD
215	BLK	4822 410 12499	PUSH BUTTON, POWER
215	GLD	4822 410 12552	PUSH BUTTON, POWER
216		3139 114 66970	LINK, POWER
217	BLK	3139 114 66770	BUTTON, PUSH BLACK
217	GLD	3139 117 88600	BUTTON, PUSH GOLD
218	BLK	3139 114 66750	KNOB, ROTARY BLACK
218	GLD	3139 117 88590	KNOB, ROTARY GOLD
219	BLK	3139 117 88040	KNOB, SELECTOR BLACK
219	GLD	3139 117 88110	KNOB, SELECTOR GOLD
220	BLK	3139 117 88030	KNOB, VOL BLACK
220	GLD	3139 117 88090	KNOB, VOL GOLD
223		4822 462 42129	FOOT FRONT
224		4822 462 42129	FOOT REAR
252		4822 532 60948	BUSH, PLASTIC
256		4822 502 13921	SCREW, STEEL
271		4822 404 10933	PLASTIC SUPPORT(LCBS 22)
▲ 385	N	4822 321 11139	MAINS CORD
▲ 385	U	4822 321 11464	MAINS CORD
▲ 385	F	4822 321 11349	MAINS CORD
1605		4822 323 10406	FLEX CABLE 15P
▲ 5011	PM7000 N	4822 146 10823	MAINS TRANSFORMER
▲ 5011	PM8000 N	4822 146 10844	MAINS TRANSFORMER
▲ 5011	PM7000 U	4822 146 10854	MAINS TRANSFORMER
▲ 5011	PM8000 F	4822 146 10853	MAINS TRANSFORMER
			PACKING
384		3139 228 82240	REMOTE CONTROL RC0465/02
387	N	3139 116 18910	USER GUIDE
387	U	3139 116 18920	USER GUIDE
387	F	3139 116 18930	USER GUIDE

8. IDLING CURRENT AND DC OFFSET VOLTAGE ALIGNMENT

8.1 Quiescent Current Adjustment for Class AB

-Set to CD mode with no input, minimum volume position & mains supply at 230 V \pm 5 %.

-Power up the unit, adjust SLOWLY 3299 (L) & 3300 (R) until voltage across L-Channel -----3335 (T007 / T006) & 3337 (T009 / T010), R-Channel ----- 3336 (T013 / T014) & 3338 (T015 / T016) is as per the table below.

Time	Voltege
after 30 sec to 1 min*	0.3 mV to < 0.4 mV

- After 30 min, the voltage should settle down to 18 mV \pm 3 mV.

* Start from cold condition.

8.2 Quiescent Current Adjustment for Class A.

- Next, switch to Class A operation. Adjust SLOWLY 3309 (L) & 3310 (R) until voltage across L-Channel ----- 3335 (T007 / T006) & 3337 (T009 / T010) , R-Channel ----- 3336 (T013 / T014) & 3338 (T015 / T016) is as per the table below.

Time	Voltage
after 0 sec to 30 sec**	65 mV to <70 mV

- After 30 min, the voltage should settle down to 90 mV \pm 5 mV.

** Continue immediately after 8.1

REMARKS:

- Please take note that for both Class AB & A alignment, at all time during adjustment, refer to the higher reading of each channel.

Quiescent Current Measurement point

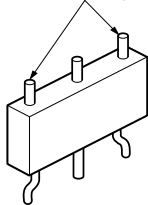

POS.No.
3335
3337
3336
3338

8.3 DC Offset.

- Adjust 3263 and 3264 until DC offset voltage is less than \pm 10 mV at Speaker output terminal.

8.アイドリング電流およびDCオフセット 電圧調整

8.1 アイドリング電流調整 (Class AB)

- 1) 本体の電源スイッチを入れる前に、ボリュームを最小に、バランス及びトーンコントロールをセンターに合わせます。
- 2) CDモードにし、電源電圧を100Vにします。
- 3) セメント抵抗、3335 (T007 / T006) 、3337 (T009 / T010) のLチャンネルと3336 (T013 / T014) 、3338 (T015 / T016) のRチャンネル各々の電圧が下記の値になるまで、半固定抵抗3299 (L) と3300 (R) をゆっくり調整します。

時間	電圧
30秒ー1分*	0.3mV以上0.4mV以下

30分後、電圧は18mV \pm 3mVに安定します。

*冷却状態からスタートします。

8.2アイドリング電流調整 (Class A)

- 1) A クラス動作に切り換えます。
- 2) セメント抵抗3335 (T007 / T006)、3337 (T009 / T010) のLチャンネルと3336 (T013 / T014)、3338(T015 / T016)のRチャンネル各々の電圧が下記の値になるまで、半固定抵抗3309 (L) と3310 (R) ゆっくり調整します。

時間	電圧
0秒ー30秒 **	65mV以上70mV以下

30分後、電圧は90mV \pm 5mVに安定します。

** 切換え後、すぐに行ってください。

注意：Aクラス動作及びABクラス動作のアイドル電流調整において、同チャンネル内の2ヶ所の測定点で指示値に差異があった場合は、高い方の電圧値が調整範囲内となるようにします。

アイドリング電流測定点

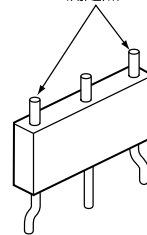

POS.No.
3335
3337
3336
3338

8.3 DCオフセット 電圧調整

DCオフセット電圧が、スピーカー出力端子で10mV以下になるまで半固定抵抗3263と3264を調整します。

9. ELECTRICAL PARTS LIST

ASSIGNMENT OF COMMON PARTS CODES. RESISTORS

R* ** : 1) GD05 x x x 140, Carbon film fixed resistor, ±5% 1/4W
 R* ** : 2) GD05 x x x 160, Carbon film fixed resistor, ±5% 1/6W
 ① Resistance value

Examples :

① Resistance value
 0.1 Ω 001 10 Ω 100 1k Ω... 102 100k Ω 104
 0.5 Ω 005 18 Ω 180 2.7k Ω... 272 680k Ω 684
 1 Ω 010 100 Ω 101 10k Ω... 103 1M Ω 105
 6.8 Ω 068 390 Ω 391 22k Ω... 223 4.7M Ω 475

Note : Please distinguish 1/4W from 1/6W by the shape of parts used actually.

CAPACITORS

C* ** : CERAMIC CAP.

3) DD1 x x x x 370, Ceramic capacitor
 Disc type
 Temp.coeff. P350-N1000, 50V
 ③ Capacity value
 ② Tolerance

Examples

② ATolerance (Capacity deviation)

± 0.25 pF 0
 ± 0.5 pF 1
 ± 5 % 5

* Tolerance of COMMON PARTS handled here are as follows :

0.5 pF - 5 p ± 0.25 pF
 6 pF - 10 pF ± 0.5 pF
 12 F - 560 pF ... ± 5 %

③ Capacity value

0.5 pF 005 3 pF 030 100 pF 101
 1 pF 010 10 pF 100 220 pF 221
 1.5 p 015 47 pF 470 560 pF 561

C* ** : CERAMIC CAP.



4) DK16 x x x 300, High dielectric constant ceramic capacitor
 Disc type
 Temp.chara. 2B4, 50V
 ④ Capacity value

Examples

④ Capacity value

100 pF 101 1000 pF 102 10000 pF 103
 470 pF 471 2200 pF 222

C* **

5) ELECTROLY CAP. () , 6) FILM CAP ()
 5) EA x x x x x x 10, Electrolytic capacitor
 One-way lead type Tolerance ±20%
 ⑤ Capacity value
 ⑥ Working voltage

Examples

⑤ Capacity value

0.1μ F 04 4.7μ F 475 100μ F 107
 0.33μ F 334 10μ F 106 330μ F 337
 1μ F 105 22μ F 226 1100μ F 118
 2200μ F 228

⑥ Working voltage

6.3 V. . .006 25 V. . .025
 10 V. . .010 35 V. . .035
 16 V. . .016 50 V. . .050

6) DF15 x x x 350 → Plastic film capacitor
 DF15 x x x 310 → One-way type, Mylar ±5% 50V
 DF16 x x x 310 → Plastic film capacitor
 One-way type, Mylar ±10% 50V

⑦ Capacity value

Examples

⑦ Capacity value

0.001μ F (1000pF) 102 0.1μ F 104
 0.0018μ F 182 0.56μ F 564
 0.01μ F 103 1μ F 105
 0.015μ F 151

NOTE : 1) The above CODES (R* **, R* **, C* **, C* **, C* **, and C* **) are omitted on the schematic diagram in some case.

- 2) On the occasion, be confirmed the common parts on the parts list.
- 3) Refer to "Common Parts List" for the other common parts (R105, DD4, DK4).

NOTE ON SAFETY FOR FUSIBLE RESISTOR :

The suppliers and their type numbers of fusible resistors are as follows :

1. KOA Corporation

Part No.(MJI)	Type No.(KOA)	Description
NH05 x x x 140	RF25S x x x x Ω J	(±5% 1/4W)
NH05 x x x 120	RF50S x x x x Ω J	(±5% 1/2W)
NH85 x x x 110	RF73B2A x x x x Ω J	(±5% 1/10W)
NH95 x x x 140	RF73B2E x x x x Ω J	(±5% 1/4W)

*Resistance value

Resistance value(0.1 Ω- 10k Ω)

2. Matsushita Electronic Components Co., Ltd

Part No.(MJI)	Type No.(MEC)	Description
NF05 x x x 140	ERD-2FCJ x x x	(±5% 1/4W)
RF05 x x x 140		
NF02 x x x 140	ERD-2FCG x x x	(±2% 1/4W)
RF02 x x x 140		

Examples :



* Resistance value

0.1 Ω 001 10 Ω 100 1k Ω.. 102 100k Ω 104
 0.5 Ω 005 18 Ω 180 2.7k Ω.. 272 680k Ω 684
 1 Ω 010 100 Ω 101 10k Ω.. 103 1M Ω 105
 6.8 Ω 068 390 Ω 391 22k Ω.. 23 4.7M Ω 475

ABBREVIATION AND MARKS

ANT. : ANTENNA	BATT. : BATTERY
CAP. : CAPACITOR	CER. : CERAMIC
CONN. : CONNECTING	DIG. : DIGITAL
HP : HEADPHONE	MIC. : MICROPHONE
μ -PRO : MICROPROCESSOR	REC. : RECORDING
RES. : RESISTOR	SPK : SPEAKER
SW : SWITCH	TRANSF. : TRANSFORMER
TRIM. : TRIMMING	TRS. : TRANSISTOR
VAR. : VARIABLE	X ' TAL : CRYSTAL

NOTE ON SAFETY:

Symbol  Fire or electrical shock hazard. Only original parts should be used to replaced any part marked with symbol  . Any other component substitution (other than original type), may increase risk of fire or electrical shock hazard.

安全上の注意 :

 がついている部品は、安全上重要な部品です。必ず指定されている部品番号の部品を使用して下さい。

POS. NO	VERS. COLOR	PART NO. (PCS)	DESCRIPTION	POS. NO	VERS. COLOR	PART NO. (PCS)	DESCRIPTION
			FUNCTION CIRCUIT BOARD				SEMICONDUCTORS
2551		4822 126 12147	CER. 22NF 10% 25V	6605		4822 130 30621	DIODE 1N4148
2552		4822 126 12147	CER. 22NF 10% 25V	6608		4822 130 30621	DIODE 1N4148
2553	N	4822 122 33519	CER. 470pF 10% 50V	7555		4822 209 31153	IC NJM2114D
2554	N	4822 122 33519	CER. 470pF 10% 50V	7551			
2555	N	4822 126 14316	CER. 680pF 10% 50V	}		4822 130 42839	FET 2SK369BL
2555	U, F	4822 122 33849	CER. 150pF 10% 50V	7554			
2556	N	4822 126 14316	CER. 680pF 10% 50V	7601		4822 130 44568	TRS. BC557B
2556	U, F	4822 122 33849	CER. 150pF 10% 50V	7602		4822 130 40959	TRS. BC547B
2559		4822 124 12023	ELECT 47μF 20% 25V				MISCELLANEOUS
2560		4822 124 12023	ELECT 47μF 20% 25V	1551		4822 265 10311	CONNECTOR, 2P
2561		4822 121 70654	FILM 2N2 10% 50V	1601		4822 265 10311	CONNECTOR, 2P
2562		4822 121 70654	FILM 2N2 10% 50V	1602	PM7000	4822 267 20453	CONNECTOR, 6P
2563		4822 121 51399	FILM 47NF 10% 50V	1602	PM8000	4822 265 11061	CONNECTOR, 6P
2564		4822 121 51399	FILM 47NF 10% 50V	1603	PM7000	4822 267 31452	CONNECTOR, CABLE/WIRE
2565		4822 121 10685	FILM 1.8NF 10% 50V	1603	PM8000	4822 265 30996	CONNECTOR, CABLE/WIRE
2566		4822 121 10685	FILM 1.8NF 10% 50V	1604		4822 267 50915	CONNECTOR, 15P
2567		4822 121 41935	FILM 12NF 5% 250V	5551		4822 280 20501	RELAY MR62 24SR
2568		4822 121 41935	FILM 12NF 5% 250V	5601			
2569		4822 124 12024	ELECT 10μF 20% 16V	}		4822 280 20501	RELAY MR62 24SR
2570		4822 124 12024	ELECT 10μF 20% 16V	5612			
2571		4822 121 10696	FILM 4.7NF 2% 50V				TAPE IN/OUT CIRCUIT BOARD
2572		4822 121 10696	FILM 4.7NF 2% 50V				CAPACITORS
2573		4822 124 12022	ELECT 220μF 20% 25V				
2574		4822 124 12022	ELECT 220μF 20% 25V	2631		4822 126 12147	CER. 22NF 10% 25V
2575		4822 124 40248	ELECT 10μF 20% 63V	}			
2601				2638			
}		4822 126 12147	CER. 22NF 10% 25V	2639			
2612				}	N	4822 122 33849	CER. 150pF 10% 50V
2613				2646			
}	N	4822 122 33849	CER. 150pF 10% 50V				RESISTORS
2624							
2647				3621			
}		4822 124 40248	ELECT 10μF 20% 63V	}		4822 116 83866	1M 5% 1/6W
2656				3628			
2659		4822 124 11566	ELECT 47μF 20% 50V	3629			
				}		4822 116 83883	470R 5% 0.5W
				3632			
			RESISTORS				MISCELLANEOUS
3551		4822 116 83872	220R 5% 0.5W				
3552		4822 116 83872	220R 5% 0.5W	1611	PM7000	4822 267 31452	CONNECTOR, CABLE/WIRE
3553		4822 116 83884	47K 5% 0.5W	1611	PM8000	4822 265 30996	CONNECTOR, CABLE/WIRE
3554		4822 116 83884	47K 5% 0.5W	1612	PM7000	4822 267 31452	CONNECTOR, CABLE/WIRE
3555				1612	PM8000	4822 265 30996	CONNECTOR, CABLE/WIRE
}		4822 116 52283	4K7 5% 0.5W				VOLUME CIRCUIT BOARD
3560							CAPACITORS
3561		4822 116 52206	120E 5% 0.5W				
3562		4822 116 52206	120E 5% 0.5W	2653		4822 122 33195	CER. 100pF 10% 50V
3563		4822 116 52175	100E 5% 0.5W	2654		4822 122 33195	CER. 100pF 10% 50V
3564		4822 116 52175	100E 5% 0.5W	2657		4822 122 33524	CER. 22pF 5% 50V
3565		4822 116 52234	100K 5% 0.5W	2658		4822 122 33524	CER. 22pF 5% 50V
3566		4822 116 52234	100K 5% 0.5W	2659		4822 126 12339	CER. 2.2NF 10%
3567		4822 116 52289	5K6 5% 0.5W	2660		4822 126 12339	CER. 2.2NF 10%
3568		4822 116 52289	5K6 5% 0.5W	2661		4822 124 12026	ELECT 22μF 20% 25V
3569		4822 116 52175	100E 5% 0.5W	2662		4822 124 12026	ELECT 22μF 20% 25V
3570		4822 116 52175	100E 5% 0.5W	2663		4822 121 10686	FILM 4.7NF 10% 50V
3571		4822 116 52234	100K 5% 0.5W	2664		4822 121 10686	FILM 4.7NF 10% 50V
3572		4822 116 52234	100K 5% 0.5W	2665		4822 124 12434	ELECT 220μF 20% 16V
3573		4822 116 83872	220R 5% 0.5W	2666		4822 124 12434	ELECT 220μF 20% 16V
3574		4822 116 83872	220R 5% 0.5W	2666		4822 124 40769	ELECT 4.7μF 20% 100V
3575		4822 052 10479	47R 5% 0.33W	2667		4822 124 40769	ELECT 4.7μF 20% 100V
3576		4822 052 10479	47R 5% 0.33W	2668		4822 124 40769	ELECT 4.7μF 20% 100V
3601				2669		4822 124 12027	ELECT 2.2μF 20% 50V
}		4822 116 83866	1M 5% 0.5W	2670		4822 124 12027	ELECT 2.2μF 20% 50V
3618				2671		4822 122 30043	CER. 10NF 80% 63V
3633		4822 050 21003	10K 1% 0.6W				
3634		4822 050 21003	10K 1% 0.6W				
3635		4822 050 21003	10K 1% 0.6W				
3637		4822 050 21003	10K 1% 0.6W				

POS. NO	VERS. COLOR	PART NO. (PCS)	DESCRIPTION	POS. NO	VERS. COLOR	PART NO. (PCS)	DESCRIPTION
			RESISTORS				
3651	PM7000	4822 116 83874	220K 5% 0.5W	3416			
3651	PM8000	4822 116 52244	15K 5% 0.5W	}		4822 116 83881	390R 5% 0.5W
3652	PM7000	4822 116 83874	220K 5% 0.5W	3422			
3652	PM8000	4822 116 52244	15K 5% 0.5W	3423			
3653		4822 050 11002	1K 1% 0.4W	}		4822 116 52234	100K 5% 0.5W
3654		4822 050 11002	1K 1% 0.4W	3426			
3655	PM7000	4822 116 52206	120E 5% 0.5W	3427			
3655	PM8000	4822 116 83876	270R 5% 0.5W	}		4822 050 21003	10K 1% 0.6W
3656	PM7000	4822 116 52206	120E 5% 0.5W	3436			
3656	PM8000	4822 116 83876	270R 5% 0.5W	3437		4822 116 52234	100K 5% 0.5W
3657				3438		4822 116 52234	100K 5% 0.5W
}		4822 116 52283	4K7 5% 0.5W	3439		4822 116 52234	100K 5% 0.5W
3662				3440		4822 116 83872	220R 5% 0.5W
3663		4822 116 83872	220R 5% 0.5W	3441		4822 116 52234	100K 5% 0.5W
3664		4822 116 83872	220R 5% 0.5W	3442		4822 050 23303	33K 1% 0.6W
3665		4822 116 83866	1M 5% 0.5W	3443		4822 116 52257	22K 5% 0.5W
3666		4822 116 83866	1M 5% 0.5W	3444		4822 116 52283	4K7 5% 0.5W
3667	PM7000	4822 050 11002	1K 1% 0.4W	3445		4822 116 52256	2K2 5% 0.5W
3667	PM8000	4822 116 52256	2K2 5% 0.5W	3446		4822 116 52257	22K 5% 0.5W
3668	PM7000	4822 050 11002	1K 1% 0.4W	3447		4822 116 52175	100E 5% 0.5W
3668	PM8000	4822 116 52256	2K2 5% 0.5W	3448			
3669		4822 116 52175	100E 5% 0.5W	}		4822 050 21003	10K 1% 0.6W
3670		4822 116 52175	100E 5% 0.5W	3451			
3671		4822 116 52234	100K 5% 0.5W	3452		4822 052 10101	100R 5% 0.33W
3672		4822 116 52234	100K 5% 0.5W	3453			
3673		4822 116 83872	220R 5% 0.5W	}		4822 050 21003	10K 1% 0.6W
3674		4822 116 83872	220R 5% 0.5W	3459			
▲ 3675		4822 052 10479	47R 5% 0.33W	3460		4822 116 52257	22K 5% 0.5W
▲ 3676		4822 052 10479	47R 5% 0.33W	3461		4822 050 21003	10K 1% 0.6W
3681	PM7000	4822 101 11789	VARIAB. 50K X2 20% 0.05W	3462		4822 116 83884	47K 5% 0.5W
3681	PM8000	4822 101 11803	VARIAB. RK16314MC(50KX2)	3463		4822 050 21003	10K 1% 0.6W
				3464		4822 050 21003	10K 1% 0.6W
				3465		4822 116 52257	22K 5% 0.5W
			SEMICONDUCTORS	3466		4822 116 52195	47E 5% 0.5W
7651				3467		4822 052 10101	100R 5% 0.33W
}		4822 130 42839	FET 2SK369BL	3468			
7654				}		4822 050 21003	10K 1% 0.6W
7655		4822 209 31153	IC NJM2114D	3488			
				3489		4822 116 83884	47K 5% 0.5W
			FRONT CIRCUIT BOARD	3490		4822 050 21003	10K 1% 0.6W
			CAPACITORS	3491		4822 116 83884	47K 5% 0.5W
2401		4822 121 51387	FILM 10NF 20% 16V	3492		4822 050 21003	10K 1% 0.6W
2403		4822 121 51387	FILM 10NF 20% 16V	3493		4822 116 83884	47K 5% 0.5W
2404		4822 124 81151	ELECT 22µF 50V	3494		4822 050 21003	10K 1% 0.6W
2405		4822 124 81151	ELECT 22µF 50V	3495		4822 116 83872	220R 5% 0.5W
2406		4822 124 80818	ELECT 22M 5.5V	3496		4822 116 52256	2K2 5% 0.5W
2407		4822 126 12882	CER. 100NF +80 20% 50V	3541	PM8000	4822 053 10332	3K30 5% 1W
2408		4822 124 81151	ELECT 22µF 50V	3542		4822 050 21003	10K 1% 0.6W
2409		4822 124 81151	ELECT 22µF 50V	3543		4822 116 83881	390R 5% 0.5W
2410		4822 121 51387	FILM 10NF 20% 16V	3544		4822 050 21003	10K 1% 0.6W
2411		4822 121 51387	FILM 10NF 20% 16V	3545		4822 116 83881	390R 5% 0.5W
2412		4822 124 81151	ELECT 22µF 50V	3546		4822 050 21003	10K 1% 0.6W
2413		4822 121 51387	FILM 10NF 20% 16V	3547		4822 050 21003	10K 1% 0.6W
2414		4822 126 12882	CER. 100NF +80 20% 50V				
2415		4822 124 81151	ELECT 22µF 50V				
2416		4822 121 51387	FILM 10NF 20% 16V				
2417		4822 121 51387	FILM 10NF 20% 16V	6401			
2425				}		4822 130 30621	DIODE 1N4148
}		4822 126 12882	CER. 100NF +80 20% 50V	6404			
2428				6405		4822 130 34174	DIODE BZX79 B4V7
				6406			
				}		4822 130 82978	LED LTL 16KPE P
			RESISTORS	6413			
3401		4822 052 10101	100R 5% 0.33W	6414	PM8000	4822 130 82978	LED LTL 16KPE P
3402		4822 116 52234	100K 5% 0.5W	6415		4822 130 82978	LED LTL 16KPE P
3403				6416		4822 130 82978	LED LTL 16KPE P
}		4822 050 21003	10K 1% 0.6W	6417		4822 130 30621	DIODE 1N4148
3408				6418		4822 130 30621	DIODE 1N4148
				7401		4822 209 15719	IC TMP47C200BN
				7402		4822 209 30193	IC LB1641

POS. NO	VERS. COLOR	PART NO. (PCS)	DESCRIPTION	POS. NO	VERS. COLOR	PART NO. (PCS)	DESCRIPTION
7404		4822 130 40959	TRS. BC547B	2509		4822 122 33293	CER. 100pF 5% 50V
7405		4822 130 40959	TRS. BC547B	2510		4822 122 33293	CER. 100pF 5% 50V
7406		4822 130 40959	TRS. BC547B	2511		4822 124 40769	ELECT 4.7μF 20% 100V
7407		4822 130 44568	TRS. BC557B	2512		4822 124 40769	ELECT 4.7μF 20% 100V
7408		4822 130 40959	TRS. BC547B	2513		4822 121 51399	FILM 47NF 10% 50V
7409				2514		4822 121 51399	FILM 47NF 10% 50V
7412		4822 130 44568	TRS. BC557B	2515		4822 124 12022	ELECT 220μF 20% 25V
7413		4822 130 40959	TRS. BC547B	2516		4822 124 12022	ELECT 220μF 20% 25V
7414		4822 130 40959	TRS. BC547B	2517		4822 124 40763	ELECT 2.2μF 100 V
7415		4822 130 44568	TRS. BC557B	2518		4822 124 40763	ELECT 2.2μF 100 V
7416		4822 130 40959	TRS. BC547B	2519		4822 121 10686	FILM 4.7NF 10% 50V
7417		4822 130 44568	TRS. BC557B	2520		4822 121 10686	FILM 4.7NF 10% 50V
7418		4822 130 40959	TRS. BC547B	2535		4822 122 33195	CER. 100pF 10% 50V
7419		4822 130 44568	TRS. BC557B	2536		4822 122 33195	CER. 100pF 10% 50V
7420		4822 130 40959	TRS. BC547B				
7421		4822 130 44568	TRS. BC557B	▲ 3203		4822 052 10479	RESISTORS 47R 5% 0.33W
7422		4822 130 40959	TRS. BC547B	3501			
7423		4822 130 44568	TRS. BC557B	}		4822 116 83866	1M 5% 0.5W
7424		4822 130 40959	TRS. BC547B	3504			
7425		4822 130 44568	TRS. BC557B	3505		4822 116 83874	220K 5% 0.5W
7426		4822 130 40959	TRS. BC547B	3506		4822 116 83874	220K 5% 0.5W
7427		4822 130 44568	TRS. BC557B	3507		4822 116 83872	220R 5% 0.5W
7428				3508		4822 116 83872	220R 5% 0.5W
7431		4822 130 40959	TRS. BC547B	3509		4822 116 52269	3K3 5% 0.5W
7432		4822 130 44568	TRS. BC557B	3510		4822 116 52269	3K3 5% 0.5W
7433		4822 130 44568	TRS. BC557B	3511		4822 101 11788	VARIAB. 10K X2 20% 0.05W
7434		4822 130 40959	TRS. BC547B	3512		4822 101 11788	VARIAB. 10K X2 20% 0.05W
			MISCELLANEOUS	▲ 3513		4822 052 10479	47R 5% 0.33W
1401		4822 276 13114	SWITCH, PUSH BUTTON	▲ 3514		4822 052 10479	47R 5% 0.33W
1402		4822 276 13114	SWITCH, PUSH BUTTON	3515		4822 116 52207	1K2 5% 0.5W
1403		4822 273 10336	SWITCH, ROTARY	3516		4822 116 52207	1K2 5% 0.5W
			SRBV14 F1620 11	3517		4822 116 52291	56K 5% 0.5W
1407		4822 267 51322	CONNECTOR, 15P	3518		4822 116 52291	56K 5% 0.5W
5400		4822 242 72527	FILTER, CERAMIC	3519		4822 116 52207	1K2 5% 0.5W
			CST4.00MGW TF01	3520		4822 116 52207	1K2 5% 0.5W
5401		4822 157 50963	COIL 2.2μH	3521		4822 116 52291	56K 5% 0.5W
7403		4822 130 10165	REMOTE RECEIVER GP1U28XP	3522		4822 116 52291	56K 5% 0.5W
				3523		4822 052 10479	47R 5% 0.33W
				▲ 3524		4822 052 10479	47R 5% 0.33W
				3525		4822 116 83872	220R 5% 0.5W
			ENCODER CIRCUIT BOARD	3526		4822 116 83872	220R 5% 0.5W
3497		4822 116 52175	RES. 100E 5% 0.5W	3527		4822 116 83874	220K 5% 0.5W
3498		4822 116 52175	RES. 100E 5% 0.5W	3528		4822 116 83874	220K 5% 0.5W
				3529		4822 101 30828	VARIAB. 100K
1404		4822 273 10237	SWITCH, ROTARY	3537		4822 116 52269	3K3 5% 0.5W
			SRRS1C(G79424930)	3538		4822 116 52269	3K3 5% 0.5W
				3539		4822 116 52234	100K 5% 0.5W
			TONE CIRCUIT BOARD	3540		4822 116 52234	100K 5% 0.5W
			CAPACITORS				SEMICONDUCTORS
2201		4822 122 30043	CER. 10NF 80% 63V			4822 130 31878	DIODE 1N4003G
2202		4822 122 30043	CER. 10NF 80% 63V	▲ 6201		4822 130 31878	DIODE 1N4003G
2203		4822 124 12025	ELECT 470μF 20% 35V	▲ 6202		4822 130 31878	DIODE 1N4003G
2204		4822 124 41329	ELECT 2200μF 20% 35V	▲ 6203		4822 130 31878	DIODE 1N4003G
2205		4822 124 12022	ELECT 220μF 20% 25V	▲ 6204		4822 130 31878	DIODE 1N4003G
2206		4822 124 12022	ELECT 220μF 20% 25V	7201		5322 209 86361	IC MC7915CT
2207		4822 124 12025	ELECT 470μF 20% 35V	7202		5322 209 71759	IC MCT7815CT
2208		4822 124 40257	ELECT 220μF 20% 63V	7203		5322 130 44349	TRS. BC635
2209		4822 124 12025	ELECT 470μF 20% 35V	7501		4822 209 73064	IC NJM2068DD
2210		4822 124 12025	ELECT 470μF 20% 35V	7502		4822 209 73064	IC NJM2068DD
2211	N	4822 122 30103	CER. 22NF 80% 63V	7503		4822 209 73064	IC NJM2068DD
2501		4822 124 81151	ELECT 22μF 50V				
2502		4822 124 81151	ELECT 22μF 50V				
2503		4822 122 33849	CER. 150pF 10% 50V	▲ 1201		4822 071 55001	FUSE 19372(500MA)
2504		4822 122 33849	CER. 150pF 10% 50V	▲ 1202		4822 071 55001	FUSE 19372(500MA)
2505		4822 124 12022	ELECT 220μF 20% 25V	1500		2422 128 02902	SWITCH, PUSH
2506		4822 124 12022	ELECT 220μF 20% 25V				
2507		4822 121 41857	FILM 10NF 5% 250V				
2508		4822 121 41857	FILM 10NF 5% 250V				

POS. NO	VERS. COLOR	PART NO. (PCS)	DESCRIPTION	POS. NO	VERS. COLOR	PART NO. (PCS)	DESCRIPTION
			POWER CIRCUIT BOARD CAPACITORS				MAIN CIRCUIT BOARD CAPACITORS
▲ 2201		2020 558 90382	CER. CERSAF KC F 250V S 10N PM20	2251		4822 124 12023	ELECT 47μF 20% 25V
▲ 2202		2020 558 90382	CER. CERSAF KC F 250V S 10N PM20	2252		4822 124 12023	ELECT 47μF 20% 25V
2204	U, F	5322 121 42498	CER. 680NF 5% 63V	2253		4822 122 33197	CER. 1NF 10% 50V
2205		4822 124 12028	ELECT 12000μF 20% 63V	2254		4822 122 33197	CER. 1NF 10% 50V
2206		4822 124 12028	ELECT 12000μF 20% 63V	2255		4822 124 12022	ELECT 220μF 20% 25V
2207	PM8000	4822 124 42391	ELECT 470μF 20% 63V	2256		4822 124 12022	ELECT 220μF 20% 25V
2208	PM8000	4822 124 42391	ELECT 470μF 20% 63V	2257	PM7000	4822 122 33519	CER. 470pF 10% 50V
2209		4822 121 51319	FILM 1μF 1% 63V	2257	PM8000	4822 126 12339	CER. 2.2NF 10%
2210		4822 124 21913	ELECT 1μF 20% 63V	2258	PM7000	4822 122 33519	CER. 470pF 10% 50V
2211		4822 124 80141	CER. 10NF 10% 50V	2258	PM8000	4822 126 12339	CER. 2.2NF 10%
2212		4822 124 80141	CER. 10NF 10% 50V	2259	PM7000	4822 122 31822	CER. 4.7pF 10% 100V
2214	U, F	5322 121 42498	CER. 680NF 5% 63V	2259	PM8000	4822 126 14164	CER. 10pF 5% 50V
2217	N	4822 121 51387	FILM 10NF 20% 16V	2260	PM7000	4822 126 14164	CER. 10pF 5% 50V
2302		4822 124 12022	ELECT 220μF 20% 25V	2260	PM8000	4822 122 31822	CER. 4.7pF 10% 100V
2304		4822 124 12056	ELECT 1000μF 20% 35V	2261	PM7000	4822 122 33519	CER. 470pF 10% 50V
2305		4822 124 40433	ELECT 47μF 20% 25V	2261	PM8000	4822 122 33197	CER. 1NF 10% 50V
2401		4822 126 12333	CER. 100NF 10% 25V	2262	PM7000	4822 122 33519	CER. 470pF 10% 50V
			RESISTORS	2262	PM8000	4822 122 33197	CER. 1NF 10% 50V
3204	U, F	4822 050 26808	6R8 1% 0.6W	2263	PM7000	2020 012 93547	ELECT 100μF 20% 63V
▲ 3207		4822 052 10108	1R 5% 0.33W	2263	PM8000	4822 124 40257	ELECT 220μF 20% 63V
▲ 3208		4822 052 10479	47R 5% 0.33W	2264	PM7000	2020 012 93547	ELECT 100μF 20% 63V
▲ 3209		4822 052 10479	47R 5% 0.33W	2264	PM8000	4822 124 40257	ELECT 220μF 20% 63V
3210		4822 116 52234	100K 5% 0.5W	2265	PM7000	2020 012 93547	ELECT 100μF 20% 63V
3211		4822 116 52234	100K 5% 0.5W	2266	PM8000	4822 124 40257	ELECT 220μF 20% 63V
3217	PM8000	4822 053 10229	22R 5% 1W	2266		4822 124 12022	ELECT 220μF 20% 25V
3218	PM8000	4822 053 10229	22R 5% 1W	2267		4822 124 12022	ELECT 220μF 20% 25V
			SEMICONDUCTORS	2269			
6202		4822 130 30621	DIODE 1N4148	2272		5322 121 42386	FILM 100NF 0.05 63V
6204	PM8000	4822 130 30621	DIODE 1N4148	2273			
▲ 6205		4822 130 10944	DIODE BRIDGE GBU6D	2273	N	4822 124 80141	CER. 10NF 10% 50V
6206				2276			
6209	PM8000	4822 130 31878	DIODE 1N4003G	2283		4822 124 21913	ELECT 1μF 20% 63V
▲ 6210							RESISTORS
6216		4822 130 31878	DIODE 1N4003G	3251		4822 116 52176	10E 5% 0.5W
6302		4822 130 30621	DIODE 1N4148	3252		4822 116 52176	10E 5% 0.5W
▲ 7302		4822 209 80817	IC L7805CV	3253		4822 116 83874	220K 5% 0.5W
			MISCELLANEOUS	3254		4822 116 83874	220K 5% 0.5W
▲ 1201		2422 128 02898	SWITCH, PUSH	3255		4822 050 11002	1K00 1% 0.4W
▲ 1205	N	4822 070 32502	FUSE 21802.5(2.5A)	3256		4822 050 11002	1K00 1% 0.4W
▲ 1206	N	4822 265 11009	MAINS OUTLET	3257		4822 116 52264	27K 5% 0.5W
▲ 1206	U, F	4822 265 11081	MAINS OUTLET	3258		4822 116 52264	27K 5% 0.5W
▲ 1209	N	4822 070 33152	FUSE 2183.15(3.15A)	3259		4822 116 52213	180E 5% 0.5W
▲ 1209	U, F	4822 070 36302	FUSE 21806.3(6.3A)	3260		4822 116 52213	180E 5% 0.5W
▲ 1213	PM8000	4822 071 54002	FUSE 19372(4A)	3261		4822 116 83872	220R 5% 0.5W
▲ 1214	PM8000	4822 071 54002	FUSE 19372(4A)	3262		4822 116 83872	220R 5% 0.5W
▲ 1215		4822 071 55001	FUSE 19372(500MA)	3263		4822 100 11213	VARIAB. 22K 30% LIN 0.1W
▲ 1216	PM8000	4822 071 55001	FUSE 19372(500MA)	3264		4822 100 11213	VARIAB. 22K 30% LIN 0.1W
1401		4822 267 41009	CONNECTOR, CABLE/WIRE	3265			
▲ 5202		4822 280 10337	RELAY VS 12MB NR (1P 12V)	3270		4822 116 83872	220R 5% 0.5W
▲ 5204	PM8000	4822 280 10344	RELAY LY2 0 DC24 B	3271		4822 116 52243	1K5 5% 0.5W
▲ 5205	N	4822 146 10828	TRANSFORMER	3272		4822 116 52243	1K5 5% 0.5W
▲ 5205	U, F	4822 146 10861	TRANSFORMER	3273		4822 050 11002	1K00 1% 0.4W
				3274		4822 050 11002	1K00 1% 0.4W
				3275		4822 116 83884	47K 5% 0.5W
				3276		4822 116 83884	47K 5% 0.5W
				3277	PM7000	4822 116 83872	220R 5% 0.5W
				3278	PM8000	4822 116 52228	680E 5% 0.5W
				3278	PM7000	4822 116 83872	220R 5% 0.5W
				3278	PM8000	4822 116 52228	680E 5% 0.5W
				3279			
				3284		4822 050 11002	1K 1% 0.4W

POS. NO	VERS. COLOR	PART NO. (PCS)	DESCRIPTION	POS. NO	VERS. COLOR	PART NO. (PCS)	DESCRIPTION
3285		4822 116 52264	27K 5% 0.5W				SEMICONDUCTORS
3286		4822 116 52264	27K 5% 0.5W	6251			
3287		4822 116 83868	150R 5% 0.5W	}		4822 130 30621	DIODE 1N4148
3288		4822 116 83868	150R 5% 0.5W	6266			
3289	PM7000	4822 116 83874	220K 5% 0.5W	6267			
3289	PM8000	4822 116 83884	47K 5% 0.5W	}		5322 130 34834	DIODE BZX79 C3V6
3290	PM7000	4822 116 83874	220K 5% 0.5W	6270			
3290	PM8000	4822 116 83884	47K 5% 0.5W	6271		4822 130 30621	DIODE 1N4148
3291	PM7000	4822 116 83874	220K 5% 0.5W	6272		4822 130 30621	DIODE 1N4148
3291	PM8000	4822 116 83884	47K 5% 0.5W	6273			
3292	PM7000	4822 116 83874	220K 5% 0.5W	}		4822 130 30842	DIODE BAV21
3292	PM8000	4822 116 83884	47K 5% 0.5W	6278			
3293		4822 116 83868	150R 5% 0.5W	6279		4822 130 30621	DIODE 1N4148
3294		4822 116 83868	150R 5% 0.5W	6280		4822 130 30621	DIODE 1N4148
3295				6281		4822 130 30621	DIODE 1N4148
}		4822 052 10109	10E 5% 0.33W	7251			
3298				}		4822 130 43233	TRS. 2SC2240GR
3299		4822 101 11787	VARIAB. 100R 30% 0.1W	7256			
3300		4822 101 11787	VARIAB. 100R 30% 0.1W	7257			
3301		4822 116 83876	270R 5% 0.5W	}		4822 130 42949	TRS. 2SA970GR
3302		4822 116 83876	270R 5% 0.5W	7260			
3303		4822 116 52207	1K2 5% 0.5W	7261		4822 130 43233	TRS. 2SC2240GR
3304		4822 116 52207	1K2 5% 0.5W	7262		4822 130 43233	TRS. 2SC2240GR
3305		4822 116 80176	1E 5% 0.5W	7263		4822 130 61009	TRS. 2SC3423(O)
3306		4822 116 80176	1E 5% 0.5W	7264		4822 130 61009	TRS. 2SC3423(O)
3309	PM8000	4822 100 20166	VARIAB. 10K 30% LIN 0.1W	7265		5322 130 61728	TRS. 2SA1360 Y
3310	PM8000	4822 100 20166	VARIAB. 10K 30% LIN 0.1W	7266		5322 130 61728	TRS. 2SA1360 Y
3311		4822 050 11002	1K 1% 0.4W	▲ 7267		4822 130 60117	TRS. 2SC3419
3312		4822 050 11002	1K 1% 0.4W	▲ 7268		4822 130 60117	TRS. 2SC3419
3313				7269	PM8000	4822 130 90347	COUPLER /PHOTO PC817
}		4822 052 10101	100R 5% 0.33W	7270	PM8000	4822 130 90347	COUPLER /PHOTO PC817
3316				7271		4822 130 41646	TRS. BF423
3317				7272		4822 130 41646	TRS. BF423
}		4822 052 10681	680R 5% 0.33W	7273		4822 130 41782	TRS. BF422
3320				7274		4822 130 41782	TRS. BF422
3321				▲ 7275		4822 130 63634	TRS. 2SA1837Y
}		4822 052 10479	47R 5% 0.33W	▲ 7276		4822 130 63634	TRS. 2SA1837Y
3324				▲ 7277		4822 130 10941	TRS. 2SC4793
▲ 3325		4822 052 10151	150R 5% 0.33W	▲ 7278		4822 130 10941	TRS. 2SC4793
▲ 3326		4822 052 10151	150R 5% 0.33W	▲ 7279	PM7000	4822 130 10942	TRS. 2SA1941
▲ 3327				▲ 7279	PM8000	4822 130 37279	TRS. 2SA1962
}		4822 052 10109	10R 5% 0.33W	▲ 7280	PM7000	4822 130 10942	TRS. 2SA1941
▲ 3334				▲ 7280	PM8000	4822 130 10983	TRS. 2SA1962
▲ 3335				▲ 7281	PM7000	4822 130 10943	TRS. 2SC5198
}		4822 116 82049	2 X R18 3W	▲ 7281	PM8000	4822 130 10984	TRS. 2SC5242
▲ 3338				▲ 7282	PM7000	4822 130 10943	TRS. 2SC5198
3339				▲ 7282	PM8000	4822 130 10984	TRS. 2SC5242
}		4822 050 21002	1K 1% 0.6W	▲ 7283	PM7000	4822 130 10942	TRS. 2SA1941
3342				▲ 7283	PM8000	4822 130 10983	TRS. 2SA1962
3343		4822 116 52257	22K 5% 0.5W	▲ 7284	PM7000	4822 130 10942	TRS. 2SA1941
3344		4822 116 52257	22K 5% 0.5W	▲ 7284	PM8000	4822 130 10983	TRS. 2SA1962
3345		4822 116 52289	5K6 5% 0.5W	▲ 7285	PM7000	4822 130 10943	TRS. 2SC5198
3346		4822 116 52257	22K 5% 0.5W	▲ 7285	PM8000	4822 130 10984	TRS. 2SC5242
3347	PM7000	4822 116 52297	68K 5% 0.5W	▲ 7286	PM7000	4822 130 10943	TRS. 2SC5198
3347	PM8000	4822 116 83882	39K 5% 0.5W	▲ 7286	PM8000	4822 130 10984	TRS. 2SC5242
3348		4822 116 52257	22K 5% 0.5W	7287		4822 130 43233	TRS. 2SC2240GR
3349		4822 116 52297	68K 5% 0.5W	7288		4822 130 43233	TRS. 2SC2240GR
3350		4822 116 52297	68K 5% 0.5W	7289		4822 130 42949	TRS. 2SA970GR
3351		4822 052 10221	220R 5% 0.33W				
3352		4822 052 10221	220R 5% 0.33W				
3353		4822 053 12109	10R 5% 3W	1255		4822 265 11068	MISCELLANEOUS CONNECTOR,LOUDSPEAKER
3354		4822 053 12109	10R 5% 3W				SOCKET LEFT
3355		4822 053 11331	330R 5% 2W	1256		4822 265 11069	CONNECTOR,LOUDSPEAKER
3356		4822 053 11331	330R 5% 2W				SOCKET RIGHT
3369	PM8000	4822 050 11002	1K 1% 0.4W	5268		4822 280 70354	RELAY VB 24MBU 510
3370	PM8000	4822 050 11002	1K 1% 0.4W	5269		4822 280 70354	RELAY VB 24MBU 510
				5270		4822 280 20501	RELAY MR62 24SR
				5351		4822 157 70599	COIL
				5352		4822 157 70599	COIL

POS. NO	VERS. COLOR	PART NO. (PCS)	DESCRIPTION	POS. NO	VERS. COLOR	PART NO. (PCS)	DESCRIPTION
			SPK PROTECT CIRCUIT BOARD				
			CAPACITORS				
2277		4822 121 51387	FILM 10NF 20% 16V				
2278		4822 124 40433	ELECT 47 μ F 20% 25V				
2279		4822 124 40433	ELECT 47 μ F 20% 25V				
2281		4822 124 21913	ELECT 1 μ F 20% 63V				
2282		4822 124 40433	ELECT 47 μ F 20% 25V				
			RESISTORS				
3357		4822 116 83884	47K 5% 0.5W				
3358		4822 053 10103	10K 5% 1W				
3360		4822 116 83874	220K 5% 0.5W				
3361		4822 050 23303	33K 1% 0.6W				
3362		4822 116 52291	56K 5% 0.5W				
3364		4822 053 10223	22K 5% 1W				
3365		4822 116 52234	100K 5% 0.5W				
			SEMICONDUCTOR				
7290		4822 209 83312	IC TA7317P				
			SPK SW CIRCUIT BOARD				
			CAPACITORS				
2533		4822 122 30043	CER. 10NF 80% 63V				
2534		4822 122 30043	CER. 10NF 80% 63V				
			RESISTORS				
3530		4822 116 52256	2K2 5% 0.5W				
3531		4822 116 52256	2K2 5% 0.5W				
3532		4822 116 52257	22K 5% 0.5W				
3533		4822 116 52176	10E 5% 0.5W				
3534		4822 116 52176	10E 5% 0.5W				
3535		4822 116 52234	100K 5% 0.5W				
			SEMICONDUCTORS				
6529		4822 130 30621	DIODE 1N4148				
7529		4822 130 44283	TRS. BC636				
7530		4822 130 44568	TRS. BC557B				
			MISCELLANEOUS				
1507		2422 128 02897	SWITCH UNIT				
1510		4822 267 31453	CONNECTOR, HLJ1540				