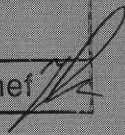

9/1353

1300x

25

ARCHIEF			
Red.	Cod.	Techn.	Art. Chef 

SERVICE
MANUAL

PM-80

8 DEC. 1989
4822 725 50887

marantz®

model PM-80

Integrated Amplifier

MARANTZ DESIGN AND SERVICE

Using superior design and selected high grade components, MARANTZ company has created the ultimate in stereo sound.

Only **original MARANTZ parts** can insure that your MARANTZ product will continue to perform to the specifications for which it is famous.

Parts for your MARANTZ equipment are generally available to our National Marantz Subsidiary or Agent.

ORDERING PARTS:

Parts can be ordered either by mail or by telex. In both cases, correct part number has to be specified. The following information must be supplied to eliminate delays in processing your order:

1. Complete address
2. Complete part numbers and quantities required
3. Description of parts
4. Model number for which part is required
5. Way of shipment
6. Signature: any order form or telex must be signed otherwise such part order will be considered as null and void.

PARTS ORDERING

Parts may be ordered at the following addresses:

AUSTRIA HORNYPHON Vertriebsgesellschaft GmbH Wienerbergstrasse 1 A 1101 Wien Austria Telex: 132.332	FINLAND MARANTZ DIVISION OF OY PHILIPS Ab Kaivokatu 8 00100 Helsinki Finland Telex: 124811	GREAT BRITAIN MARANTZ AUDIO U.K. Ltd Unit 15/16 Saxon Way Industrial Estate Moor Lane Harmondsworth UB7 0LW Great Britain Telex: 935196	SAUDI ARABIA AL ALAMIAH ELECTRONICS P.O.Box 5954 University Street Riyadh 11432 Saudi Arabia Telex: 401530	SWITZERLAND DYNAVOX ELECTRONICS Route de Villars 105 1701 Fribourg Switzerland Telex: 942377
BELGIUM SVD DIVISICN MARANTZ Industrialaan 1 1720 Groot-Bijgaarden Belgium Telex: 24466	FRANCE MARANTZ FRANCE 4 Rue Bernard Palissy 92600 Asnières France Telex: 611651	GREECE SHERTON ELECTRONICS S.A. P.O.Box 21025 Hippocrates Street 188 Athens 11471 Greece Telex: 216.795	SOUTH AFRICA MARANTZ DIVISION OF PHILIPS S.A. Main Road Martindale P.O. Box. 58088 Newville 21114 South Africa	TURKEY DOGRUOL Ltd. I.M.C. 6 Blok N°6310 Unkapani Istanbul Turkey Telex: 22085
CHILE MARANTZ DIVISION OF PHILIPS S.A. AV. Santa Maria, 0760 Casilla 2687 Santiago Telex: 240.239	GERMANY MARANTZ GERMANY GmbH Max-Planck-Strasse 22 6072 Dreieich 1 Germany Telex: 529821	JAPAN MARANTZ JAPAN, Inc. 35-1, 7-chome, Sagamiono Sagamihara-shi, Kanagawa Japan	SPAIN PHONO S.A. Ignacio Iglesias 10 Badalona (Barcelona) Spain Telex: 59355	MALTA CACHIA & GALEA Republic Street, 68D Valetta Telex: 1682
DENMARK MARANTZ DIVISION OF PHILIPS SERVICE A/S Prags Boulevard 80 Postbox 1919 DK-2300 København S Denmark Telex: 31201	THE NETHERLANDS Elpro Marantz Wint Hontlaan 28 3526 KV Utrecht The Netherlands Telex: 4748	KUWAIT AL ALAMIAH ELECTRONICS Ussama Building Fahd al Saleem Street P.O.Box 23781 Safat-Kuwait Telex: 22694	SWEDEN MARANTZ DIVISION OF PHILIPS Försäljning AB Tegeluddsvägen 1 S-115 84 Stockholm Sweden Telex: 14060	PORTUGAL MARANTZ Divisao philips S.A. service Outurela-carnaxide 2795 LinDA-A-VELHA Telex: 43906
	NORWAY MARANTZ DIVISION OF PHILIPS A/S Sandstuveien 40 0680 Oslo 6 Norway Telex: 72640	ITALY MARANTZ ITALIANA S.P.A. Via Chiese, 74 20126 Milano Italy		

All of the above locations are fully equipped to take care of your total service needs. Because various countries have differing configuration requirements, it is necessary that you contact the service facility in your particular country. In the event that there is no service location listed for your country, please, contact the nearest facility for the necessary assistance.

In case of difficulties, do not hesitate to contact the Technical Department at abovementioned address.

MODEL PM-80 INTEGRATED AMPLIFIER



TABLE OF CONTENTS

SECTION	PAGE
1. BLOCK DIAGRAM	4
2. SCHEMATIC DIAGRAM AND PARTS LOCATION (PATTERN SIDE)	6
3. EXPLODED VIEW AND PARTS LIST	17
4. TEST EQUIPMENT REQUIRED FOR SERVICING	21
5. VOLTAGE CONVERSION	21
6. IDLING CURRENT ADJUSTMENTS	22
7. HOW TO CHANGE THE SUPPLY VOLTAGE (A/N/T/W Versions)	22
8. ELECTRICAL PARTS LIST	23

MODEL PM-80 TECHNICAL SPECIFICATIONS (DIN)

Power output

FTC8 Ohms (20 Hz–20 kHz)	100/25 W (Class A)
DIN 8 Ohms/4 Ohms	110/180 W

IHF dynamic power

8 Ohms/4 Ohms/2 Ohms	135/220/340 W
THD at 8 Ohms RMS rated output	0.008%
Intermodulation distortion	0.008%
Damping factor	150

Magnetic cartridge input

Input sensitivity impedance	2.5 mV/47kOhm
Accuracy of frequency response to IEC RIAA	0.5 dB
Signal to noise ratio	86 dB

Moving coil cartridge input

Input sensitivity impedance	250 μ V/100 Ohm
Signal to noise ratio	72 dB

Tuner/CD/Aux/Tape inputs

Input sensitivity impedance	150 mV/33kOhm
Signal to noise ratio	96 dB
Frequency response (–3 dB limits)	10 Hz–70 kHz
Tone characteristic (100 Hz and 10 kHz)	\pm 6 dB
Channel separation (1 kHz/10 kHz)	>85/>65 dB

General

Power Requirements

N and W/T versions	220/240V AC, 50/60 Hz
E versions (4 voltages)	110/120/220/240V AC, 50/60 Hz

Dimensions

Panel Width	420 mm
Panel Height	146 mm
Depth	334 mm

Weight

Unit alone	13 kg
------------------	-------

Specifications subject to change without prior notice.

1. BLOCK DIAGRAM

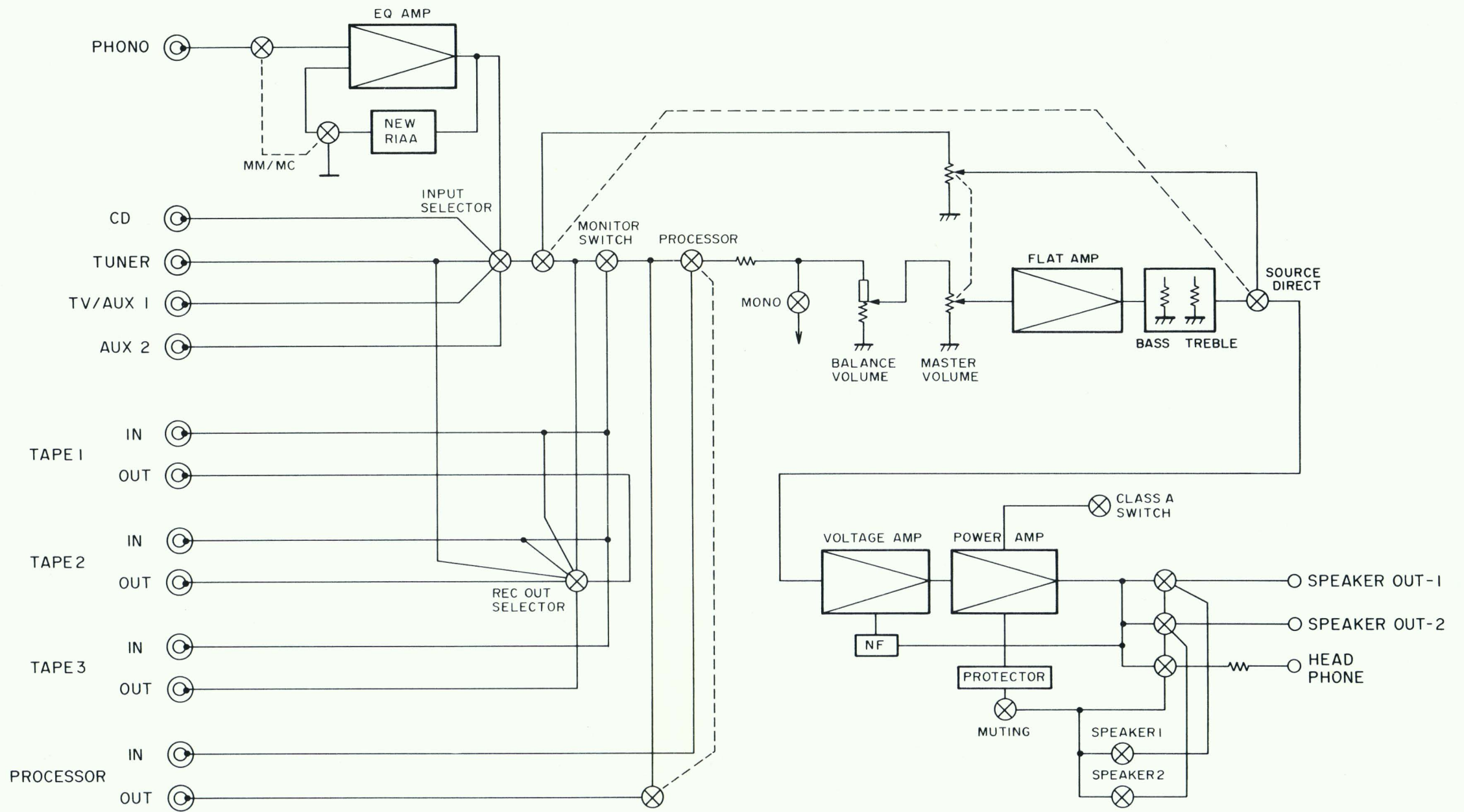

2. SCHEMATIC DIAGRAM AND PARTS LOCATIONS (PATTERN SIDE)

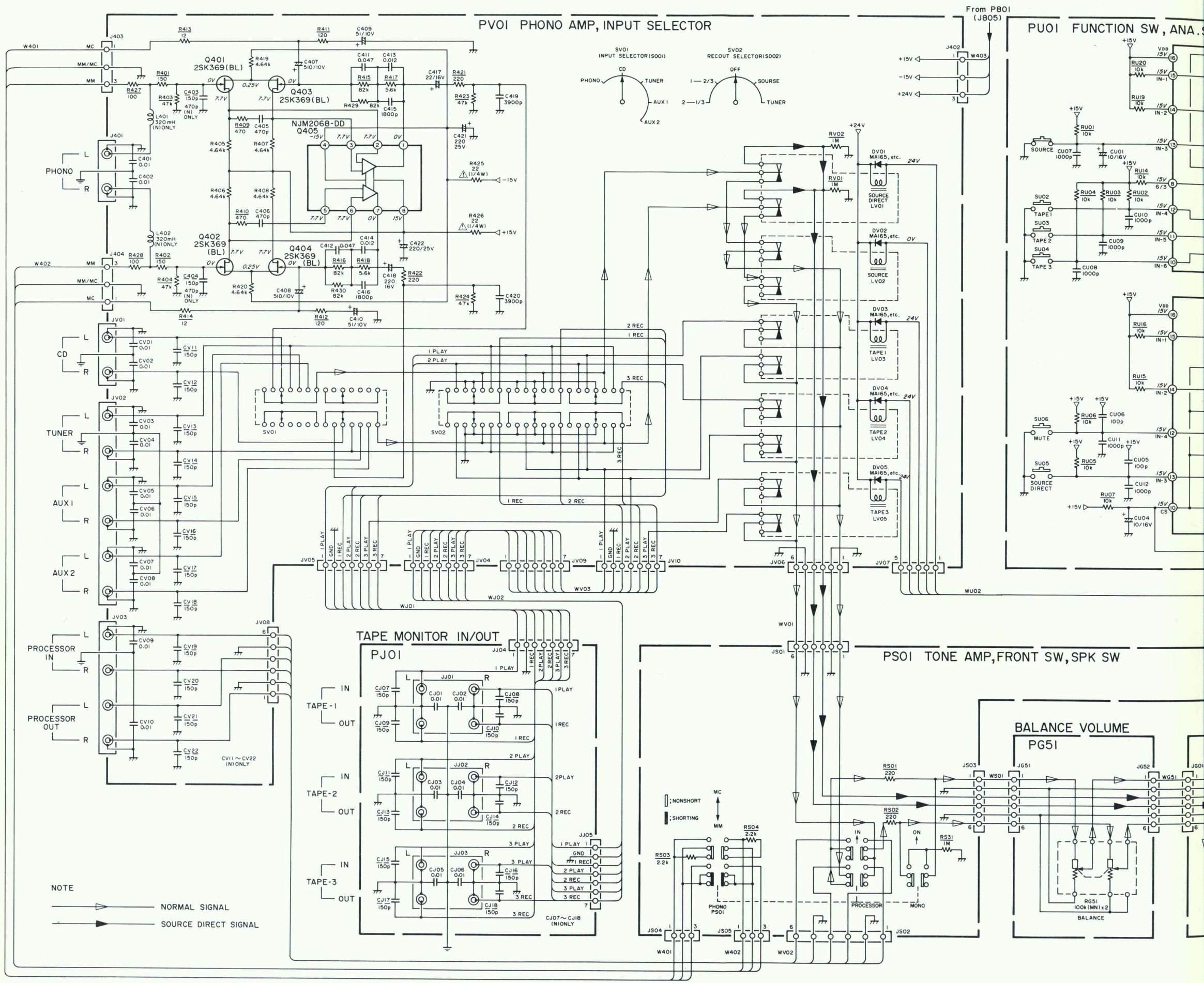

THE SIGNAL LINES OF L-CH AND R-CH HAVE BE SEPARATED THE GROUND LINES.

PU01 FUNCTION SW, ANA. SW

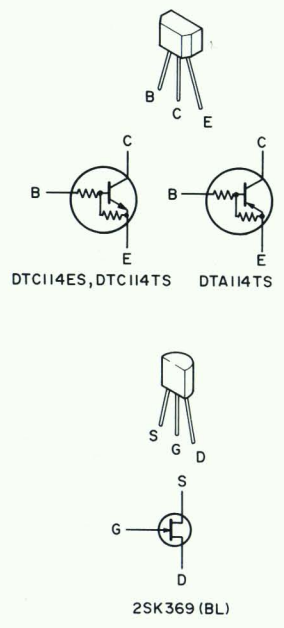
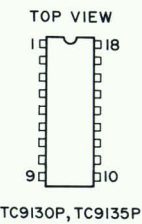
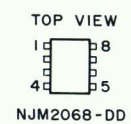
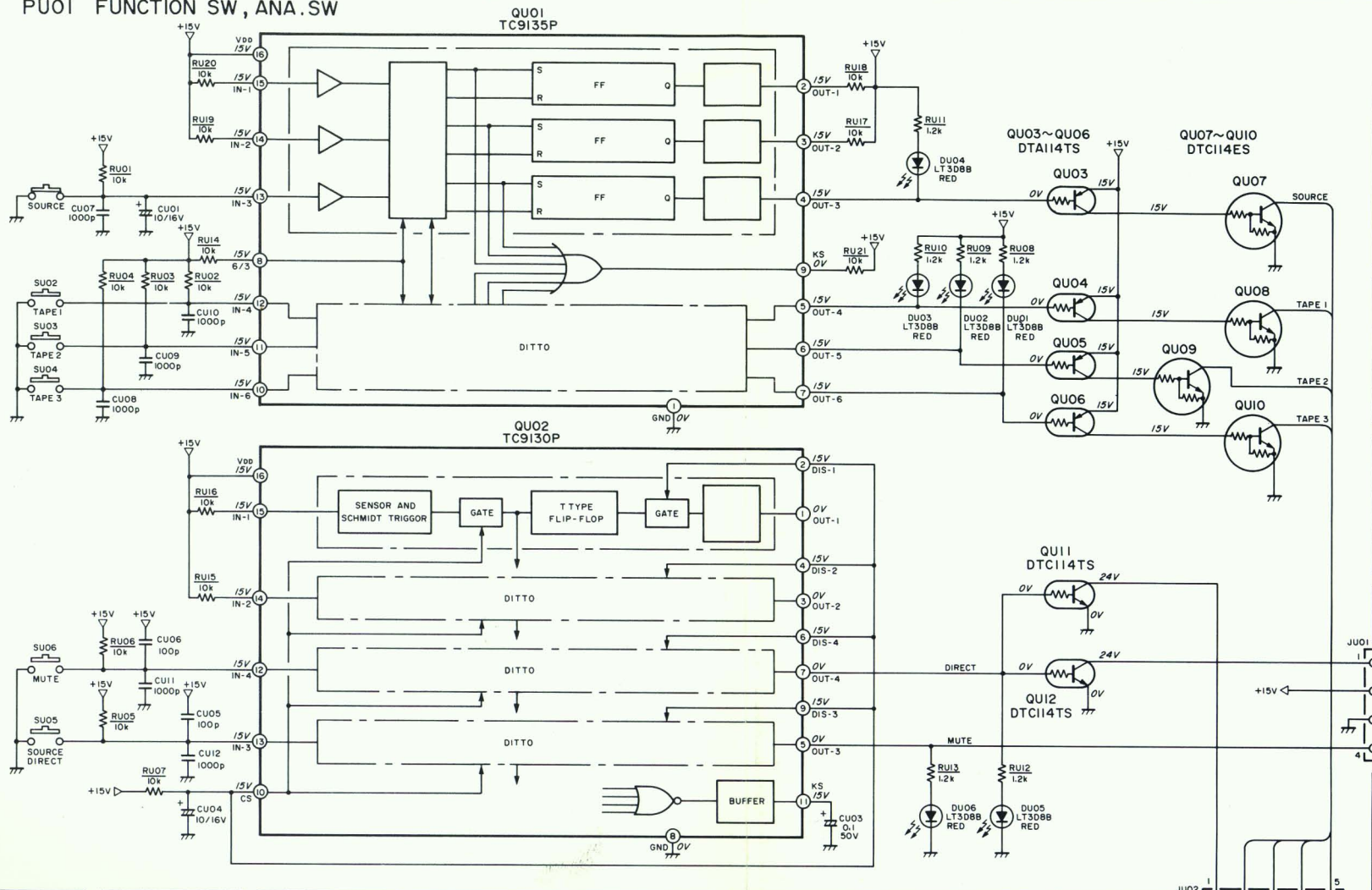

FRONT SW, SPK SW

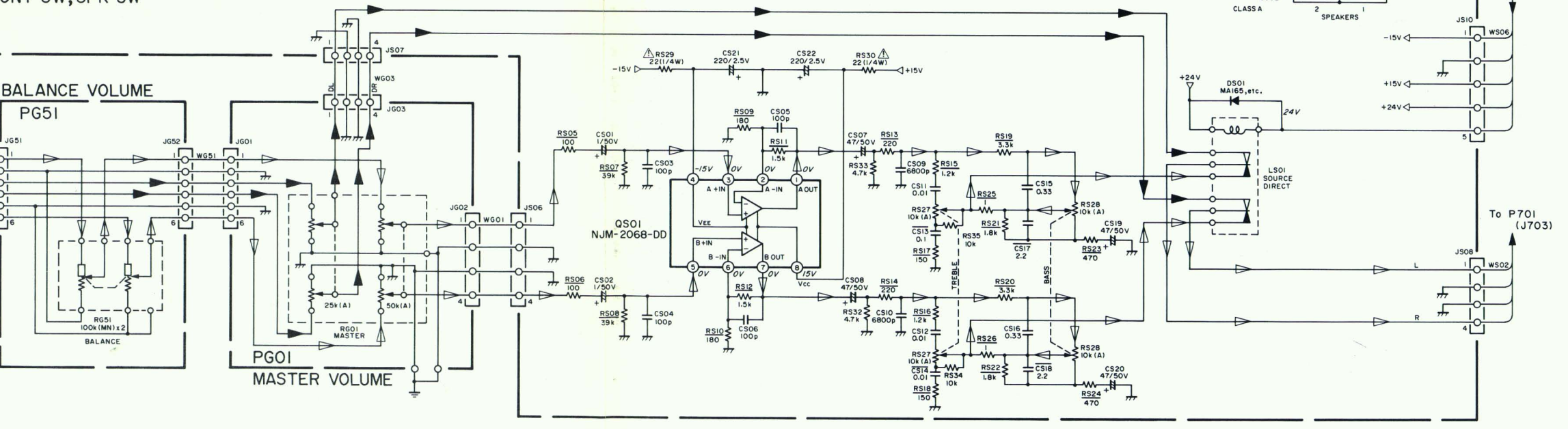

PS01

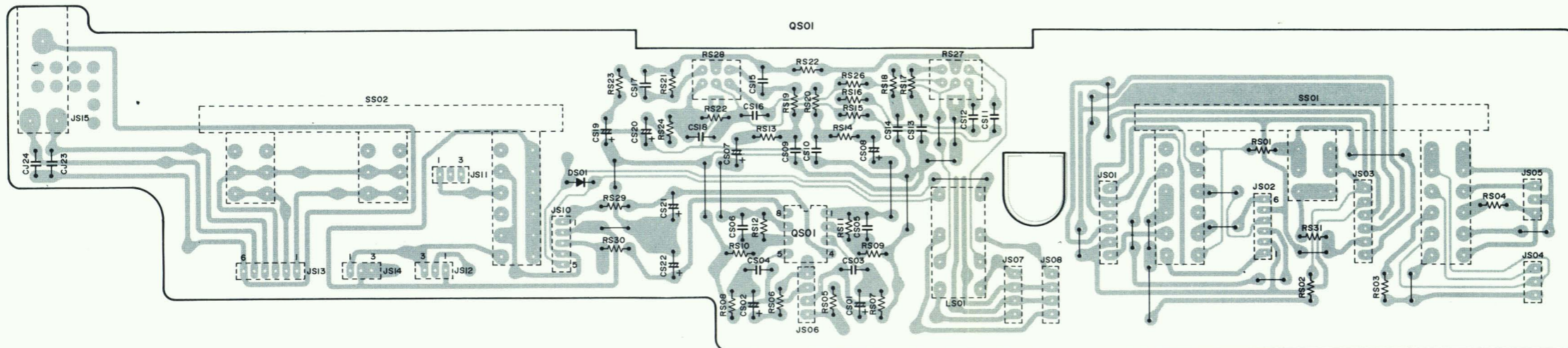

PG01

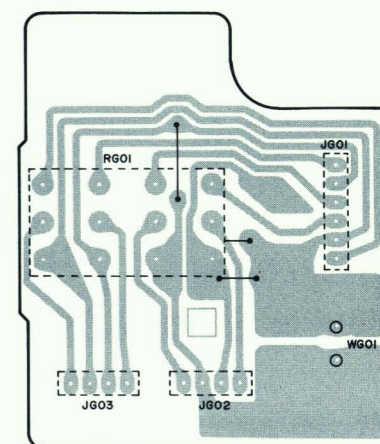

Q401~Q404

Q405

PV01

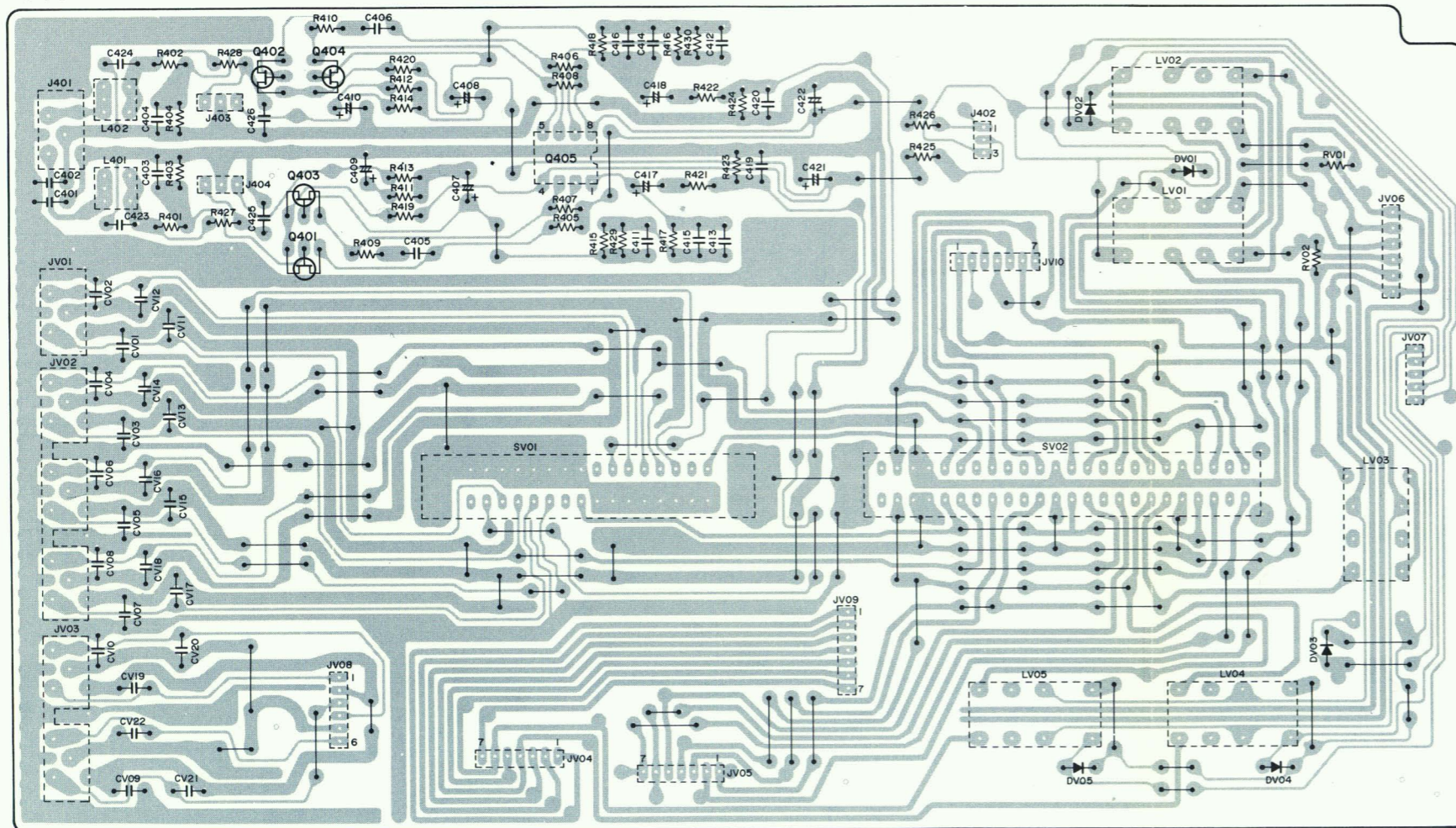

PJ01

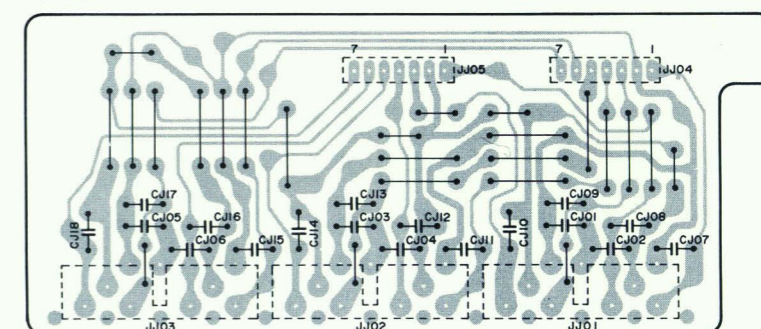

QU02 QU03~QU12 QU01

PU01

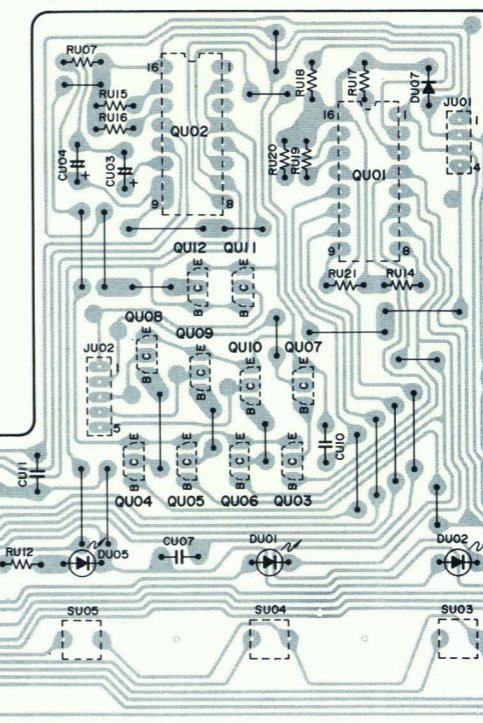

PG51

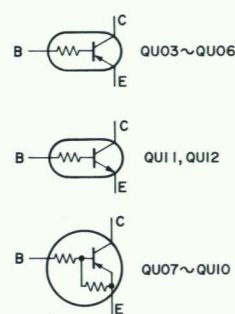
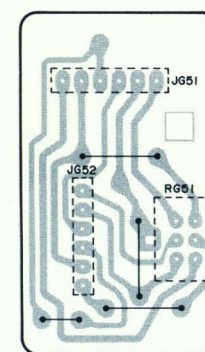

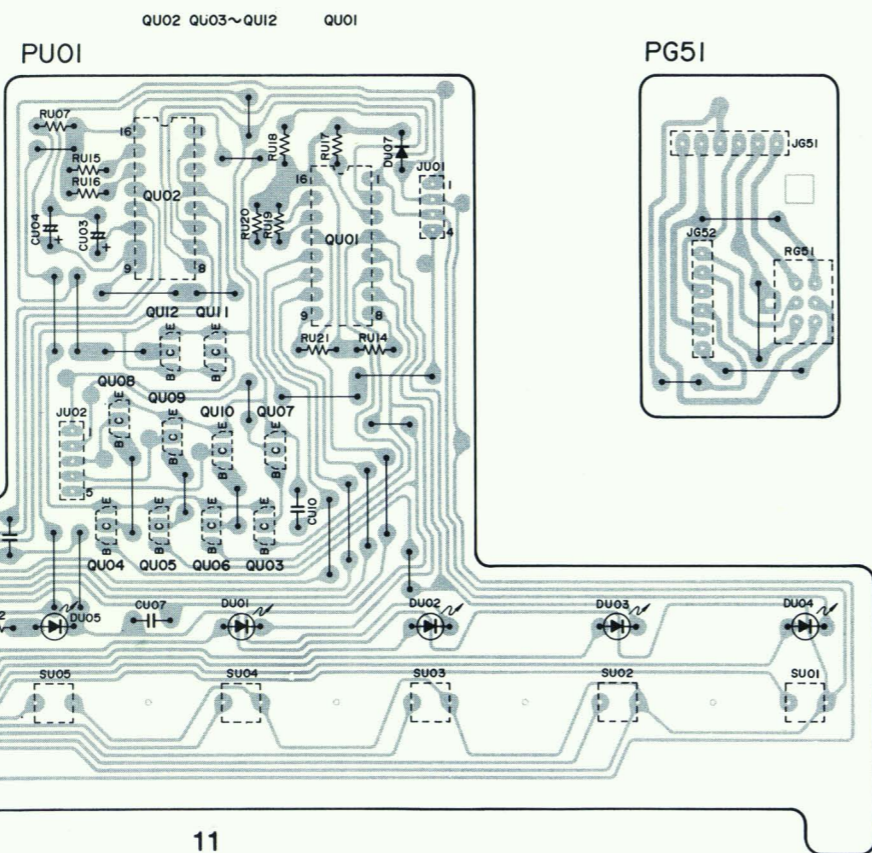
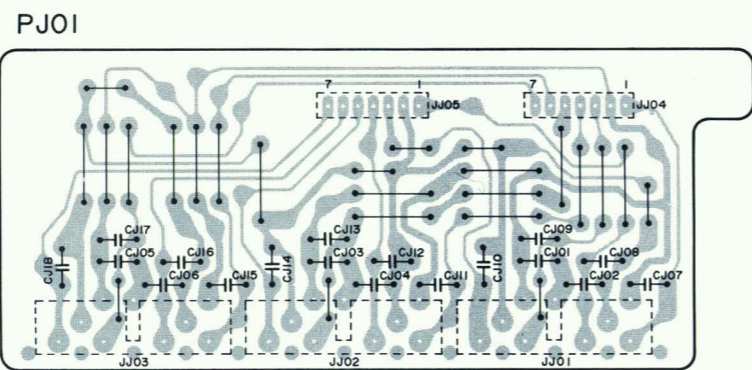
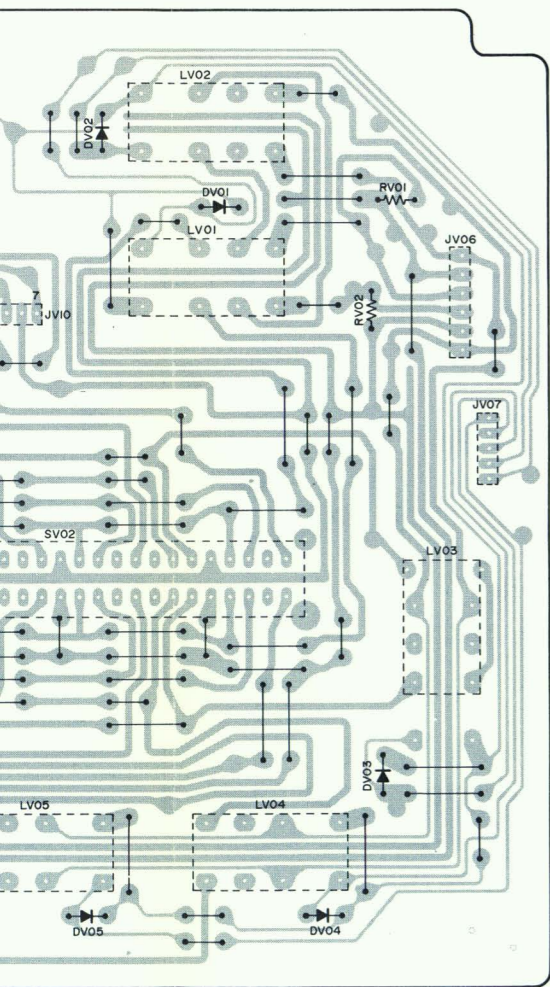
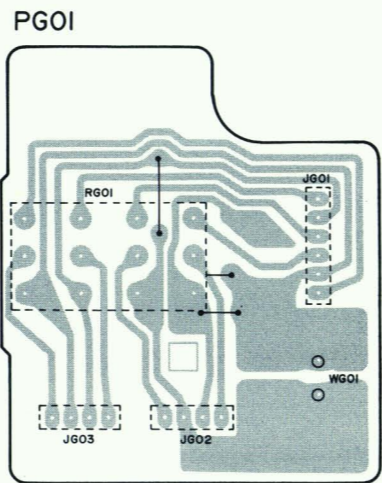
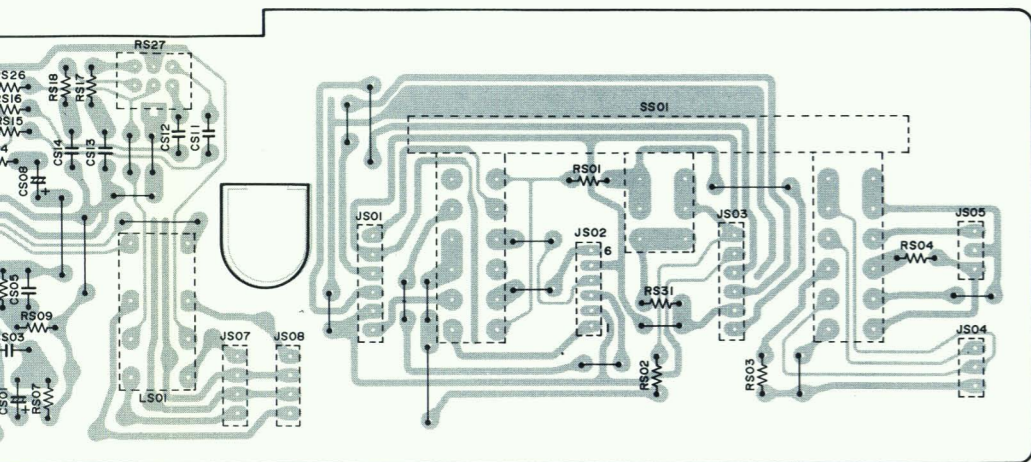

P701 MAIN AMP.

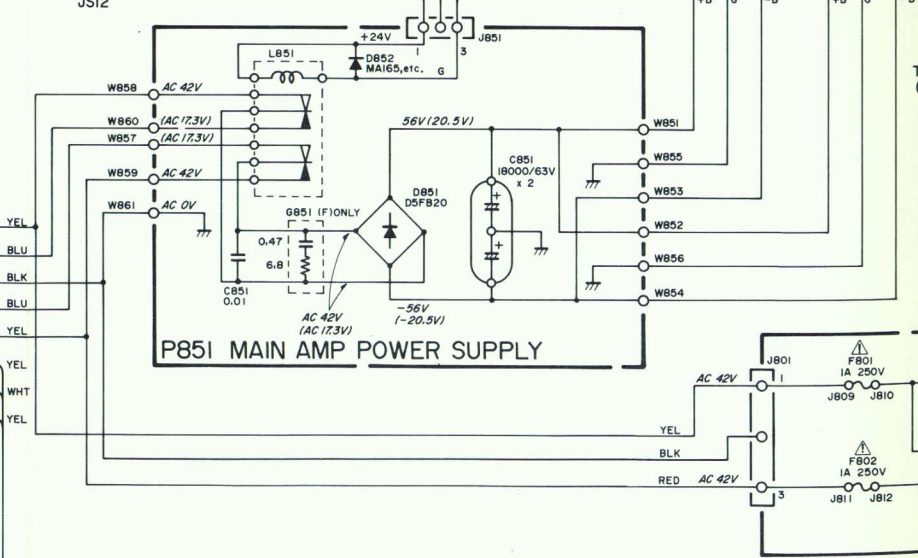
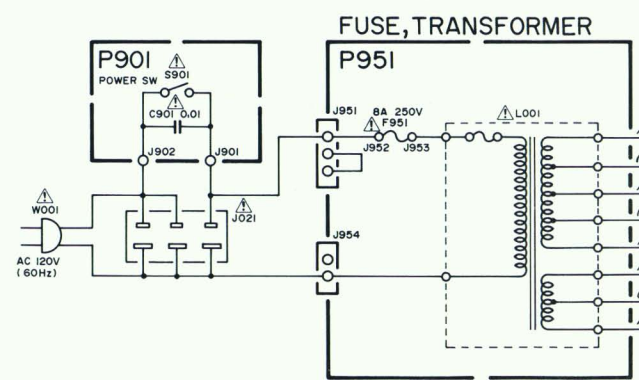
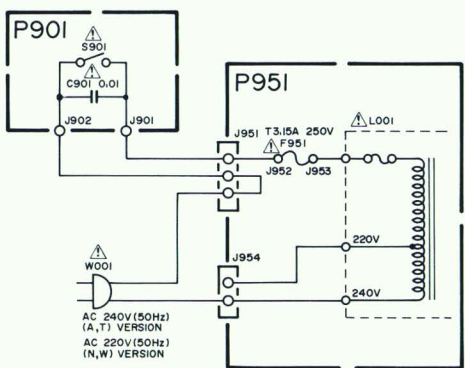
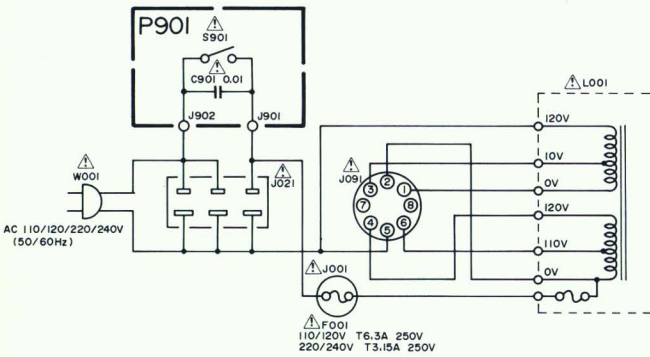
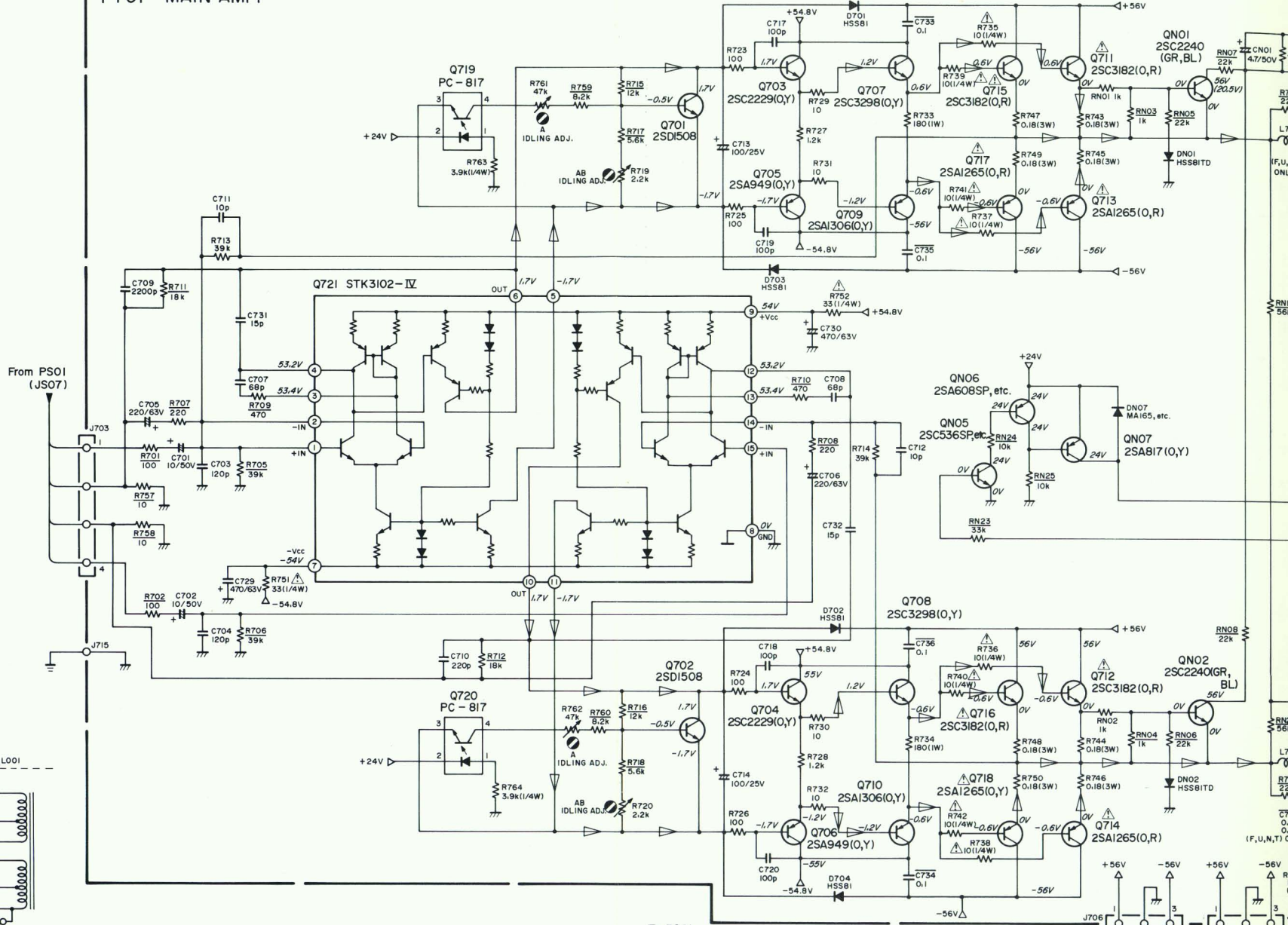

NOTE NORMAL SIGNAL

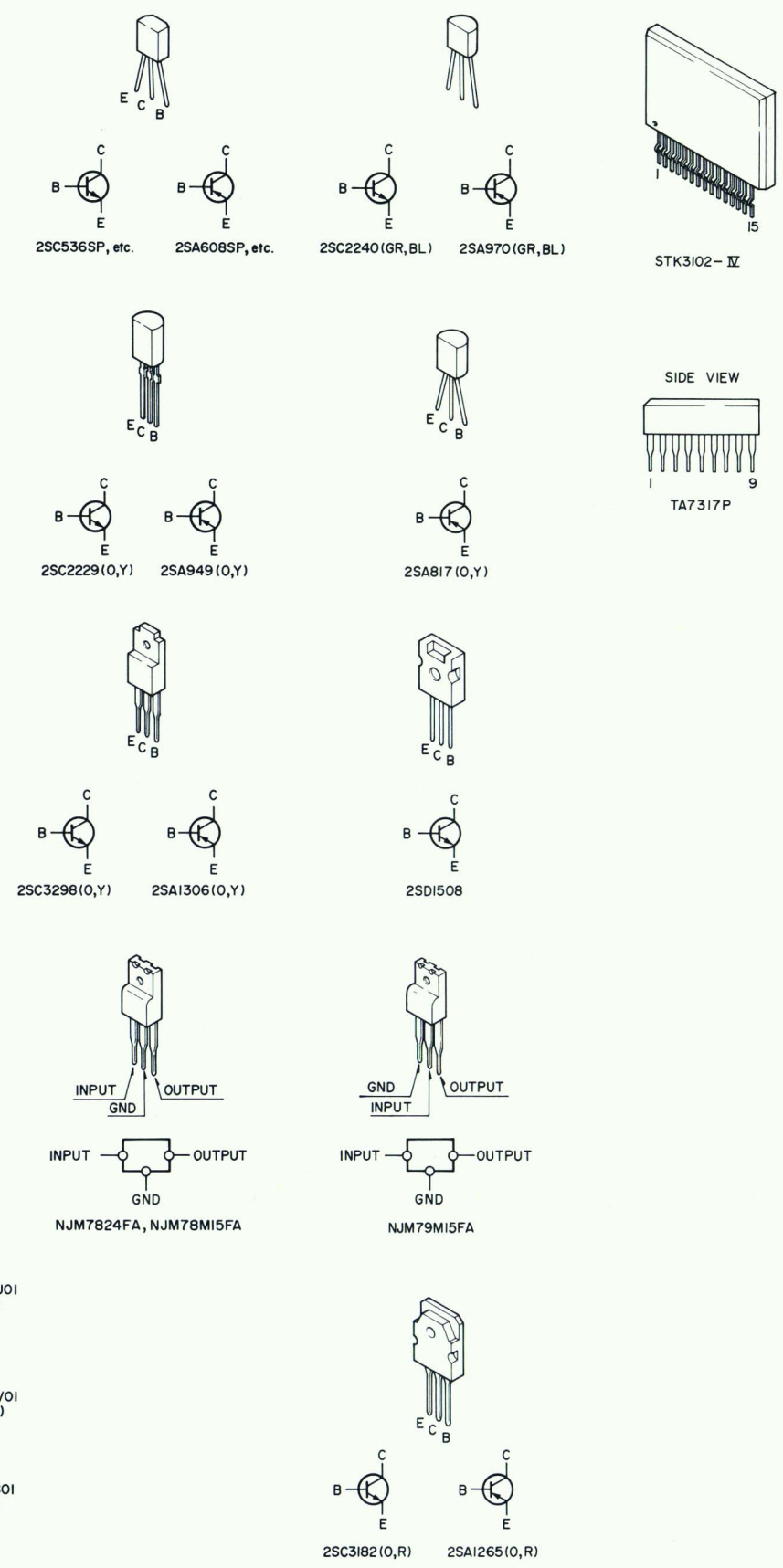
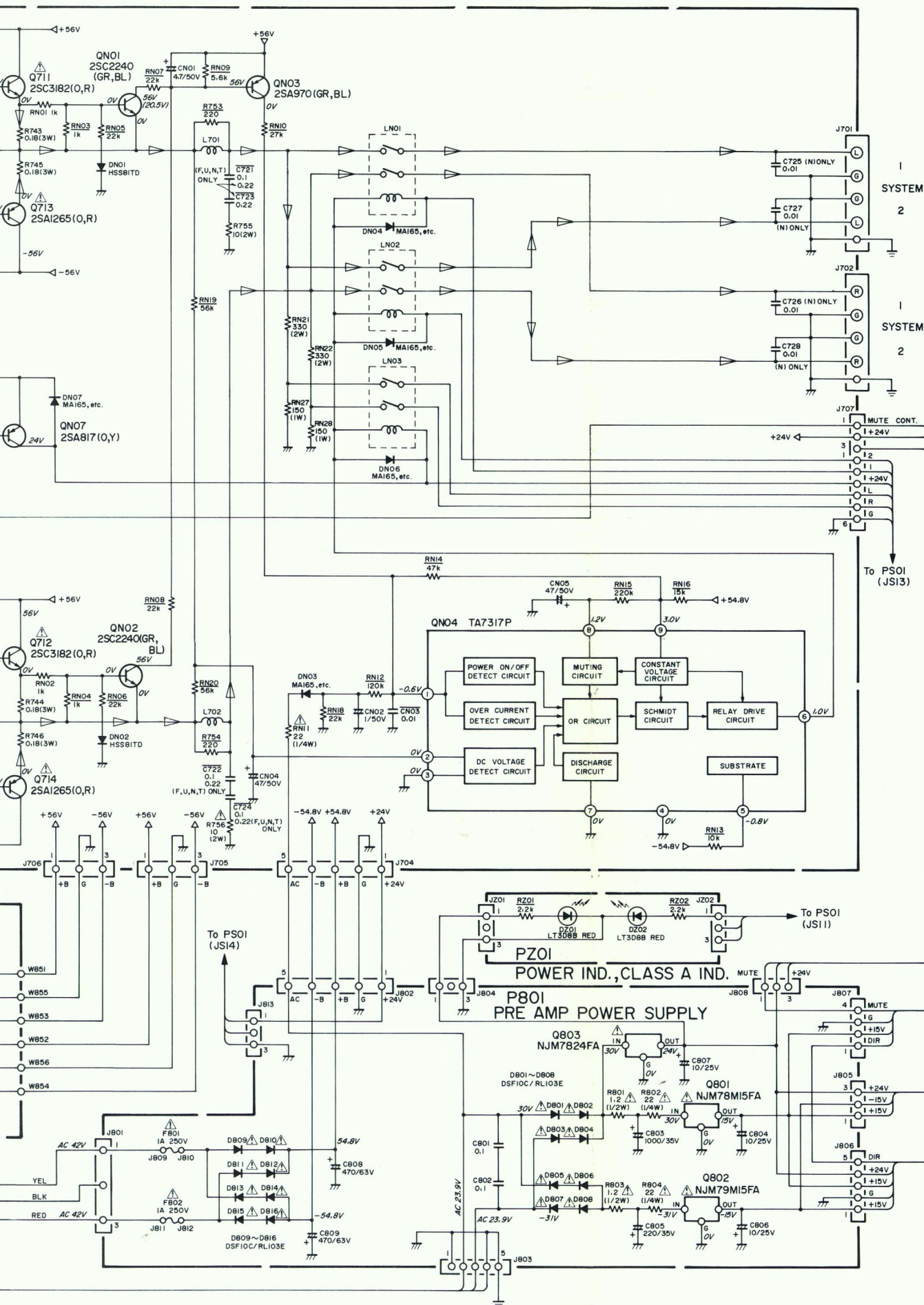

P951

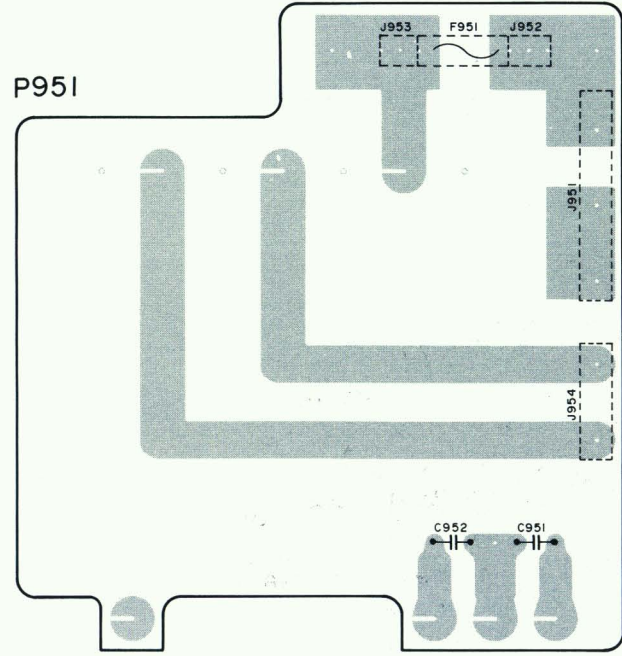

P701

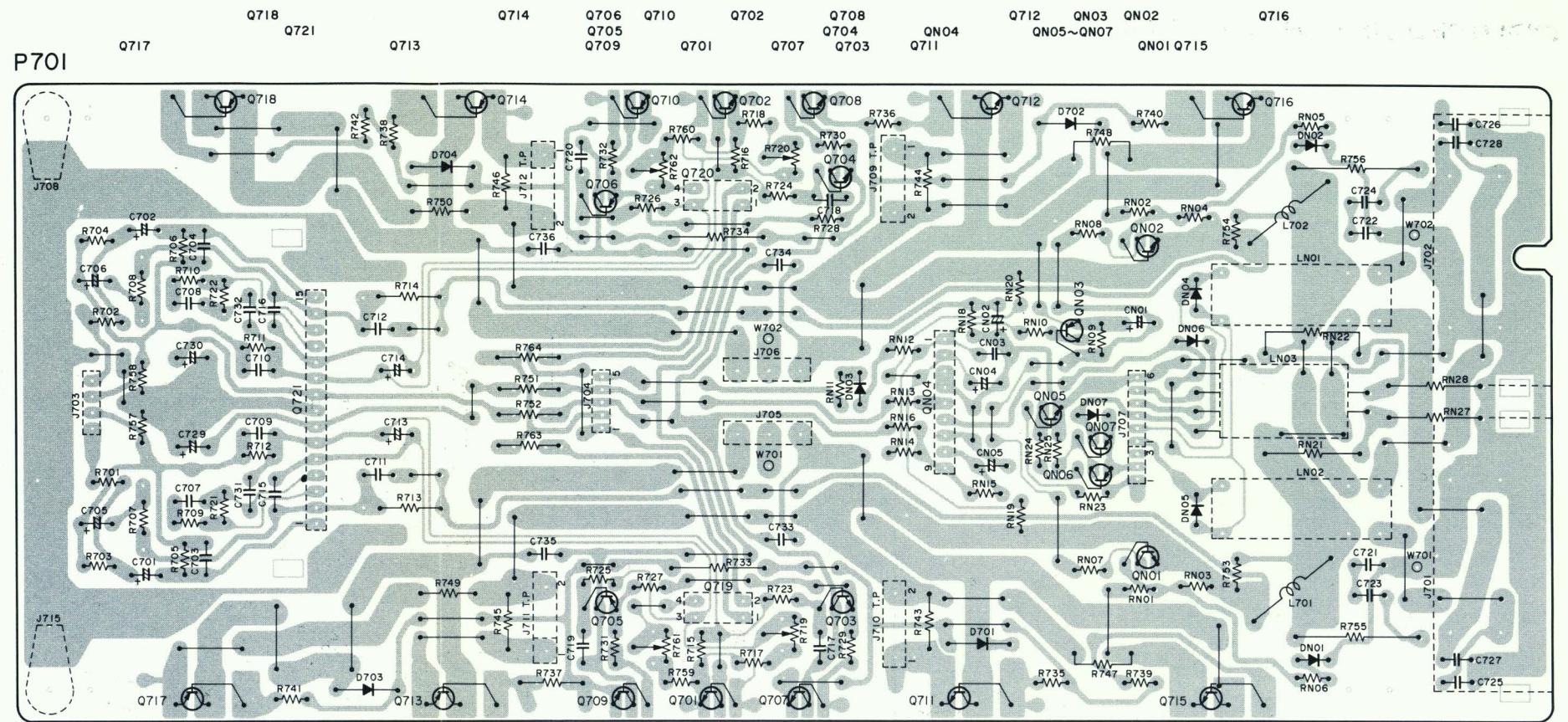

P851

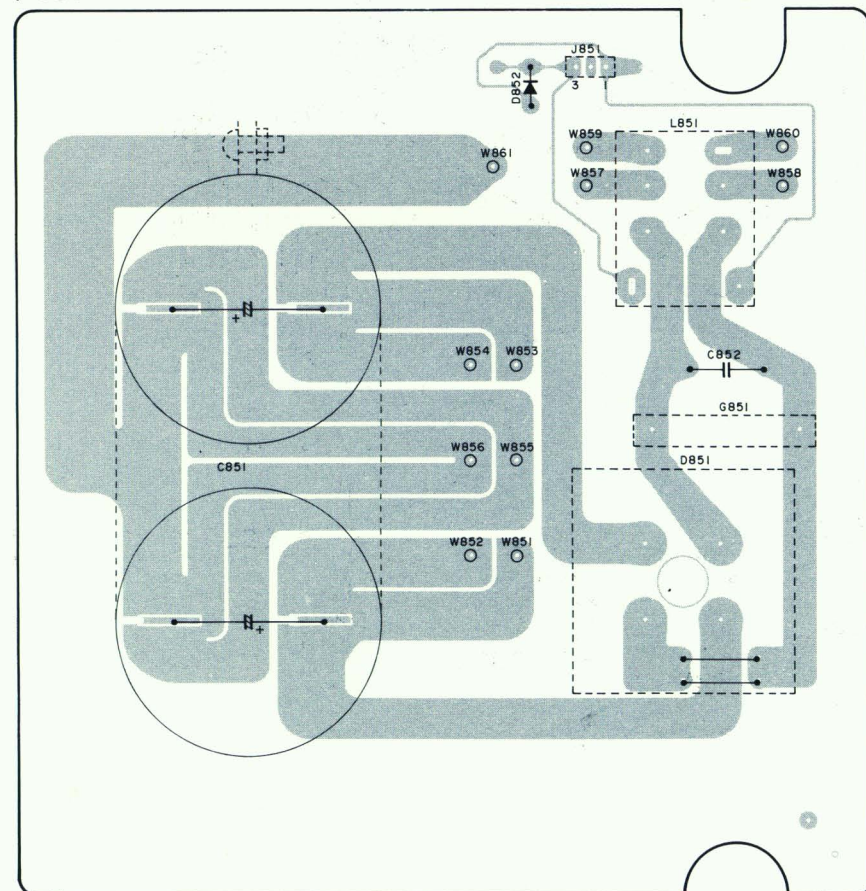

P801

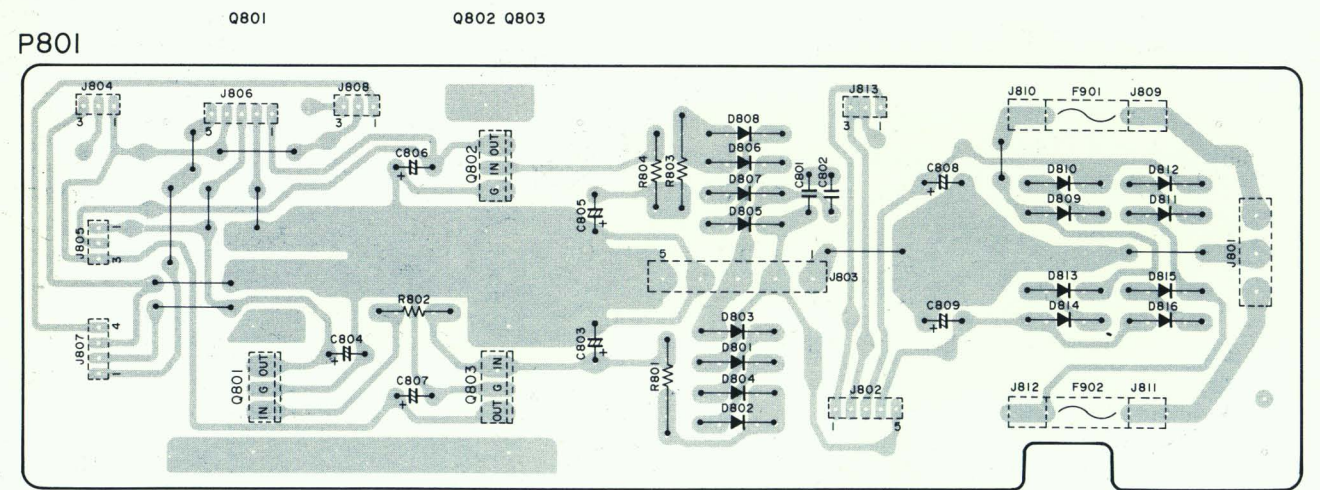

P901

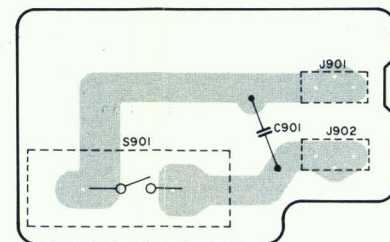

PZ01

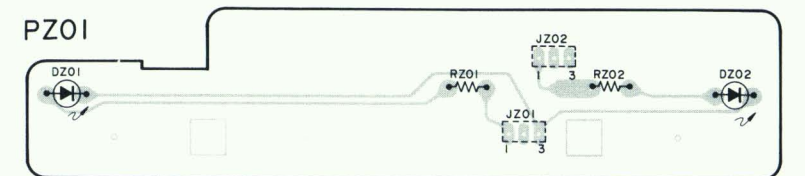

3. EXPLODED VIEW AND PARTS LIST

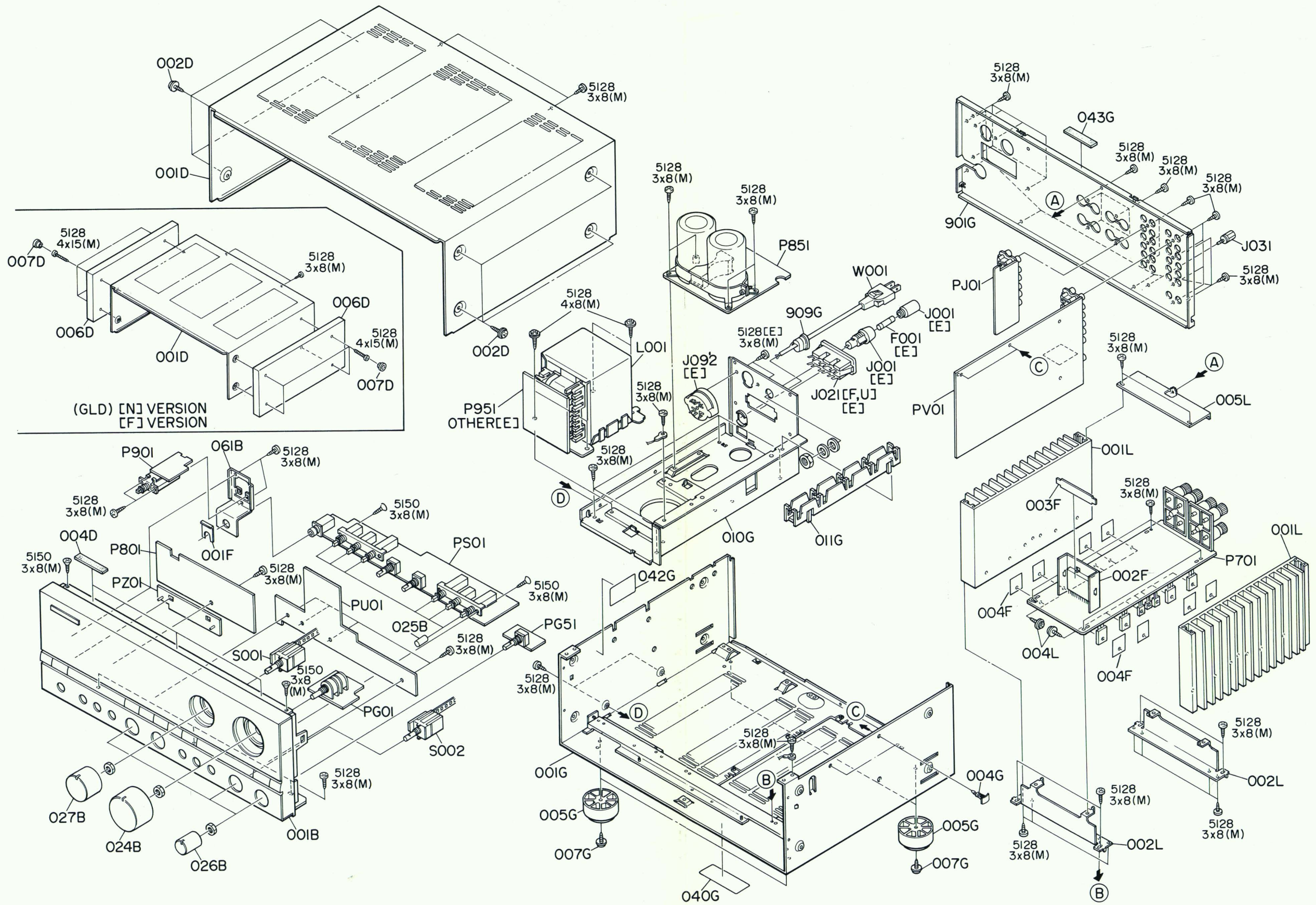

REF. DESIG.	PART NO.	DESCRIPTION
001B		Front Panel Assembly (BLK) [A, E, N, T, W] Front Panel Assembly (GLD) [E, W] Front Panel Assembly (GLD) [N]
024B	4822 413 41542	Knob, Volume (GLD)
	4822 413 41544	Knob, Volume (BLK)
025B	4822 410 60334	Button, Push (GLD)
	4822 410 60343	Button, Push (BLK)
026B	4822 411 10051	Knob, Rec/Tone/Bal. (GLD)
	4822 413 31551	Knob, Rec/Tone/Bal. (BLK)
027B	4822 413 31582	Knob, Selector (GLD)
	4822 413 41545	Knob, Selector (BLK)
007D	4822 444 60607	Cap, Side Panel (GLD) [N]
003F 004F	4822 492 63973	Spring (Q721) Insulator
005G 909G	4822 462 41189 4822 532 60948	Leg Bushing, AC Cord [A, N, T, W] Bushing, AC Cord [E]
004L	4822 502 12512	B.T. Screw B3 x 12
F001	4822 253 30027	Fuse 3.15A 250V [E]
F002	4822 253 30243	Fuse 6.3A 250V [E]
J001	4822 256 30233	Jack, Fuse Holder [E]
J021	4822 264 30266	Jack, AC Outlet [E]
J031	4822 290 40297	Terminal, GND
J092	4822 272 10227	Voltage Selector [E]
△ L001	4822 146 21453 4822 146 21454	Power Transformer [A, N, T, W] Power Transformer [E]
S001	4822 273 10188	Rotary Switch, Input
S002	4822 273 10189	Rotary Switch, Recout
001T	4822 736 20417	User Manual

4. TEST EQUIPMENT REQUIRED FOR SERVICING

This table lists the test equipment required for servicing the Model PM-80 Stereo Amplifier.

Item	Use
Distortion Analyzer	Distortion measurements
Audio Oscillator	Sinewave and squarewave signal source
ACVTVM	Voltage measurements (AC)
Oscilloscope	Waveform analysis and trouble shooting and ASO aignment
Circuit Tester	Trouble shooting
DCVTVM	Voltage measurements (DC)
AC Wattmeter	Monitors primary power to amplifier
Line Voltmeter	Monitors potential of primary power to amplifier
Variable Autotransformer	Adjust level of primery power to amplifier
Shorting Plug	Shorts amplifier input to eliminate noise pickup

5. VOLTAGE CONVERSION

● EUROPEAN MODEL ONLY

To convert the unit to a different power source voltage, change the position as illustrated in the drawing below.

VOLTAGE SELECTOR

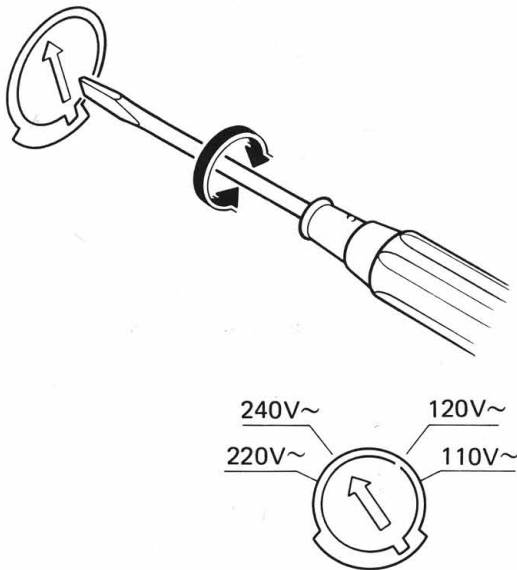

CAUTION

DISCONNECT POWER SUPPLY CORD FROM AC OUTLET BEFORE CONVERTING VOLTAGE.

6. IDLING CURRENT ADJUSTMENT

- (1) Before switching the power ON, set the Master Volume control to the minimum position and the Balance and Tone controls to the center positions. Then, rotate the semi-fixed resistors R719/R761 (L CH) and R720/R762 (R CH) on the PC board P701 fully counterclockwise.
- (2) Connect a digital voltmeter, set for the DC voltage input, to the pertinent test points (the marked ones of P709-P712) on the PC board P701. (Positive: J709/J710, Negative: J711/J712)
- (3) After the completion of the above setup, perform the class-AB idling current adjustment as follows:
Switch the power ON and adjust the semi-fixed resistors R719 (L CH) and R720 (R CH) on the PC board P701 according to the reading of the digital voltmeter. The setting values are 18 mV (50.0 mA) of the both channels.
- (4) After the completion of the class-AB idling current adjustment, perform the class-A idling current adjustment as follows:
Press the Class-A switch and adjust the semi-fixed resistors R761 (L CH) and R762 (R CH) on the PC board P701 to set 198 mV (500 mA).

Note: For idling current adjustment, be sure to perform first class-AB, then class-A.

Please refer to the table below.

Elapsed time after power ON	Idling current setting value
30 sec. ~ 1 min.	17.5 mV
1 min. ~ 2 min.	19 mV
2 min. ~ 4 min.	19.5 mV
More than 4 min.	18 mV

Elapsed time after Class-A switch ON	Idling current setting value
30 sec. ~ 1 min.	205 mV
1 min. ~ 2 min.	205 mV
2 min. ~ 4 min.	200 mV
More than 4 min.	198 mV

Note on Safety:

Symbol Δ Fire or electrical shock hazard. Only original parts should be used to replace any part marked with symbol Δ . Any other component substitution (other than original type), may increase risk of fire or electrical shock hazard.

7. HOW TO CHANGE THE SUPPLY VOLTAGE (A/N/T/W Versions)

With the PM-80 A and T Versions, the rated supply voltage of 240V can be changed to 220V. In the same way, the 220V rated supply voltage of the PM-80 N and W Versions can be changed to 240V.

Refer to the following diagram for the voltage change procedure.

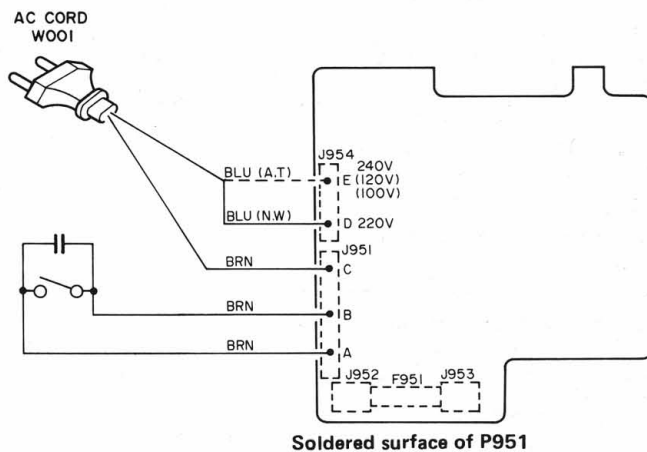

After binding solder around the terminal, bundle the brown wire and blue wire together and tighten them with a tightener.

Note on Terminals J951 and J954

Wrapping terminals J951 and J954 on the P951 PC board are critical components for the safety. Please observe the following caution when working these terminals.

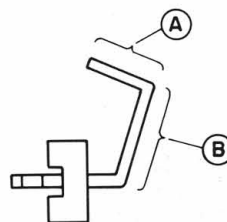

Terminal side view

Wrapping shall be performed within range A .
When binding up solder, apply solder within range B .

8. ELECTRICAL PARTS LIST

ASSIGNMENT OF COMMON PARTS CODES.

RESISTOR

- R*****: (1) GD05 --- 140, Carbon film fixed resistor, ±5%, 1/4W
R***: (2) GD05 --- 160, Carbon film fixed resistor, ±5%, 1/6W

① — Resistance value

Examples

- ① Resistance value
 0.1Ω...001 10Ω...100 1kΩ...102 100kΩ...104
 0.5Ω...005 18Ω...180 2.7kΩ...272 680kΩ...684
 1Ω...010 100Ω...101 10kΩ...103 1MkΩ...105
 6.8Ω...068 390Ω...391 22kΩ...223 4.7MkΩ...475

(Note) Please distinguish 1/4W from 1/6W by the shape of parts used actually.

C***: CERAMIC CAP.

- (1) DD1 --- 370, Ceramic condenser
 Disc type
 Temp. coeff. P350 ~ N1000, 50V

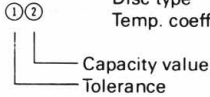

Examples

- ① Tolerance (Capacity deviation)
 ±0.25pF...0
 ±0.5pF...1
 ±5%...5

* Tolerance of COMMON PARTS handled here are as follows:

- 0.5pF ~ 5pF...±0.25pF
 6pF ~ 10pF...±0.5pF
 12pF ~ 560pF...±5%

② Capacity value

- 0.5pF...005 3pF...030 100pF...101
 1pF...010 10pF...100 220pF...221
 1.5pF...015 47pF...470 560pF...561

C***: CERAMIC CAP.

- (1) DK16 --- 300, High dielectric constant ceramic condenser
 Disc type
 Temp. chara. 2B4, 50V

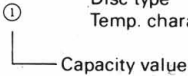

Example

- ② Capacity value
 100pF...101 1000pF...102 10000pF...103
 470pF...471 2200pF...222

C***: ELECTROLY CAP. (≠), FILM CAP. (≠)

- (1) EA --- 10, Electrolytic condenser
 One-way lead type, Tolerance ±20%

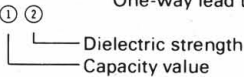

Examples

- ① Capacity value
 0.1μF...104 4.7μF...475 100μF...107
 0.33μF...334 10μF...106 330μF...337
 1μF...105 22μF...226 1100μF...108
 2200μF...228

- ② Working voltage
 6.3V...006 25V...025
 10V...010 35V...035
 16V...016 50V...050

- (2) DF15 --- 350, Plastic film condenser
 One-way type, Mylar ±5% 50V

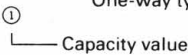

Examples

- ① Capacity value
 0.001μF (1000pF)...102 0.1μF...104
 0.0018μF...182 0.56μF...564
 0.01μF...103 1μF...105
 0.015μF...153

REF. DESIG.	PART NO.	DESCRIPTION
		PG01-MASTER VOLUME CIRCUIT BOARD
PG01	4822 101 30649	Variable Resistor 50KΩx2 Special
		PG51-BALANCE VOLUME CIRCUIT BOARD
RG51	4822 101 30652	Variable Resistor 100KΩ(MN)x2
		PJ01-TAPE MONITOR IN/OUT CIRCUIT BOARD
CJ01 ? CJ06	4822 122 32486	Ceramic 0.01μF +80% -20%
JJ01	4822 266 30284	Terminal, 4P; RCA
JJ02	4822 266 30284	Terminal, 4P; RCA
JJ03	4822 266 30284	Terminal, 4P; RCA
		PS01-TONE AMP/FRONT/SPK. CIRCUIT BOARD
		PS01-CAPACITORS
CJ23	4822 122 32486	Ceramic 0.01μF +80% -20% [N]
CJ24	4822 122 32486	Ceramic 0.01μF +80% -20% [N]
CS01	4822 124 41543	Elect 1μF 50V
CS02	4822 124 41543	Elect 1μF 50V
CS03		Film 100pF ±5%
CS04		Film 100pF ±5%
CS05		Film 100pF ±5%
CS06		Film 100pF ±5%
CS07	4822 124 22276	Elect 47μF 50V
CS08	4822 124 22276	Elect 47μF 50V
CS09	4822 121 42824	Film 6800pF ±5%
CS10	4822 121 42824	Film 6800pF ±5%
CS11	4822 121 42754	Film 0.01μF ±5%
CS12	4822 121 42754	Film 0.01μF ±5%
CS17		Elect 2.2μF 50V (BP)
CS18		Elect 2.2μF 50V (BP)
CS19	4822 124 22276	Elect 47μF 50V
CS20	4822 124 22276	Elect 47μF 50V
CS21	4822 124 90365	Elect 220μF 25V
CS22	4822 124 90365	Elect 220μF 25V
		PS01-RESISTORS
RS27	4822 101 30651	10KΩ(A)x2
RS28	4822 101 30651	10KΩ(A)x2
△ RS29	4822 113 90119	22Ω ±2% ¼W, Fuse
△ RS30	4822 113 90119	22Ω ±2% ¼W, Fuse
		PS01-SEMICONDUCTORS
QS01	4822 209 73064	IC NJM2068DD
DS01	4822 130 33305	Diode 1SS176, etc.
		PS01-MISCELLANEOUS
JS15	4822 267 31119 4822 267 31126	Jack, Headphone (GRY/GLD) Jack, Headphone (BLK/GLD)
SS01	4822 276 30346	Push Switch
SS02	4822 276 30405	Push Switch
LS01	4822 280 20195	Relay, SZ-2104

REF. DESIG.	PART NO.	DESCRIPTION
C711	4822 121 43128	Film 10pF ±10%
C712	4822 121 43128	Film 10pF ±10%
C713	4822 124 41535	Elect 100μF 25V
C714	4822 124 41535	Elect 100μF 25V
C717	4822 121 51036	Film 100pF ±5%
C718	4822 121 51036	Film 100pF ±5%
C719	4822 121 51036	Film 100pF ±5%
C720	4822 121 51036	Film 100pF ±5%
C725	4822 122 32486	Ceramic 0.01μF +80% -20% [N]
C726	4822 122 32486	Ceramic 0.01μF +80% -20% [N]
C727	4822 122 32486	Ceramic 0.01μF +80% -20% [N]
C728	4822 122 32486	Ceramic 0.01μF +80% -20% [N]
C729	4822 124 23071	Elect 470μF 63V
C730	4822 124 23071	Elect 470μF 63V
C731	4822 121 43129	Film 15pF ±10%
C732	4822 121 43129	Film 15pF ±10%
P701-RESISTORS		
RN01	4822 111 91257	1KΩ ±5% 1/6W
RN02	4822 111 91257	1KΩ ±5% 1/6W
△ RN11	4822 113 90119	22Ω ±2% ¼W, Fuse
RN21	4822 116 60494	330Ω ±5% 2W, Metal
RN22	4822 116 60494	330Ω ±5% 2W, Metal
RN27	4822 116 60337	150Ω ±5% 1W
RN28	4822 116 60337	150Ω ±5% 1W
R713	4822 116 82032	39KΩ ±5% ½W
R714	4822 116 82032	39KΩ ±5% ½W
R716	4822 100 20681	2.2KΩ, Trimming
R719	4822 100 20681	2.2KΩ, Trimming
R723	4822 111 91285	100Ω ±5% 1/6W
R724	4822 111 91285	100Ω ±5% 1/6W
R725	4822 111 91285	100Ω ±5% 1/6W
R726	4822 111 91285	100Ω ±5% 1/6W
R727	4822 111 91287	1.2KΩ ±5% 1/6W
R728	4822 111 91287	1.2KΩ ±5% 1/6W
R729	4822 111 91291	10Ω ±5% 1/6W
R730	4822 111 91291	10Ω ±5% 1/6W
R731	4822 111 91291	10Ω ±5% 1/6W
R732	4822 111 91291	10Ω ±5% 1/6W
R733	4822 116 60342	180Ω ±5% 1W
R734	4822 116 60342	180Ω ±5% 1W
△ R735	4822 111 41271	10Ω ±5% ¼W
△ R742	4822 116 80171	0.18Ω ±10% 3W
R743		
R750		
△ R751	4822 116 60445	33Ω ±5% ½W, Fusible
△ R752	4822 116 60445	33Ω ±5% ½W, Fusible
R755	4822 111 90726	10Ω ±5% 2W
△ R756	4822 111 90726	10Ω ±5% 2W
R761	4822 100 11372	47KΩ, Trimming
R762	4822 100 11372	47KΩ, Trimming
R763	4822 111 91249	3.9KΩ ±5% ¼W
R764	4822 111 91249	3.9KΩ ±5% ¼W
P701-SEMICONDUCTORS		
DN01	4822 130 80837	Diode HSS81TD
DN02	4822 130 80837	Diode HSS81TD
DN03	4822 130 33305	Diode MA165, etc.
DN07		
D701	4822 130 80837	Diode HSS81TD
D704		

REF. DESIG.	PART NO.	DESCRIPTION
QN01	4822 130 43233	Transistor 2SC2240(GR, BL)
QN02	4822 130 43233	Transistor 2SC2240(GR, BL)
QN03	4822 130 42951	Transistor 2SA970(GR, BL)
QN04	4822 209 83312	IC TA7317P
QN05	4822 130 42298	Transistor 2SC536SP, etc.
QN06	4822 130 42715	Transistor 2SA608SP, etc.
QN07	4822 130 60693	Transistor 2SA817(O, Y)
Q701	4822 130 60526	Transistor 2SD1508
Q702	4822 130 60526	Transistor 2SD1508
Q703	4822 130 43225	Transistor 2SC2229(O, Y)
Q704	4822 130 43225	Transistor 2SC2229(O, Y)
Q705	4822 130 42941	Transistor 2SA949(O, Y)
Q706	4822 130 42941	Transistor 2SA949(O, Y)
Q707	4822 130 60525	Transistor 2SC3298(O, Y)
Q708	4822 130 60525	Transistor 2SC3298(O, Y)
Q709	4822 130 60524	Transistor 2SA1306(O, Y)
Q710	4822 130 60524	Transistor 2SA1306(O, Y)
△ Q711	4822 130 43306	Transistor 2SC3182(O, R)
△ Q712	4822 130 43306	Transistor 2SC3182(O, R)
△ Q713	4822 130 43019	Transistor 2SA1265(O, R)
△ Q714	4822 130 43019	Transistor 2SA1265(O, R)
△ Q715	4822 130 43306	Transistor 2SC3182(O, R)
△ Q716	4822 130 43306	Transistor 2SC3182(O, R)
△ Q717	4822 130 43019	Transistor 2SA1265(O, R)
△ Q718	4822 130 43019	Transistor 2SA1265(O, R)
Q719	4822 130 90347	Photo Unit PC-817
Q720	4822 130 90347	Photo Unit PC-817
Q721	4822 209 73453	IC STK3102-4
J701	4822 290 60837	Terminal, Speaker [A, E, T, W]
J702	4822 290 60841	Terminal, Speaker [N]
J702	4822 290 60836	Terminal, Speaker [A, E, T, W]
J702	4822 290 60839	Terminal, Speaker [N]
LN01	4822 280 20197	Relay DH24SU
LN02	4822 280 20197	Relay DH24SU
LN03	4822 280 20196	Relay L-24(M)
L701	4822 157 51739	Coil, Speaker
L702	4822 157 51739	Coil, Speaker
P701-MISCELLANEOUS		
Terminal, Speaker [A, E, T, W]		
Terminal, Speaker [N]		
Terminal, Speaker [A, E, T, W]		
Terminal, Speaker [N]		
P801-PRE AMP POWER SUPPLY CIRCUIT BOARD		
P801-CAPACITORS		
C801	4822 122 32486	Ceramic 0.01μF +80% -20%
C802	4822 122 32486	Ceramic 0.01μF +80% -20% [N, T]
C803	4822 124 90356	Elect 1000μF 35V
C804	4822 124 41534	Elect 10μF 25V
C805	4822 124 41538	Elect 220μF 35V
C806	4822 124 41534	Elect 10μF 25V
C807	4822 124 41534	Elect 10μF 25V
C808	4822 124 23071	Elect 470μF 63V
C809	4822 124 23071	Elect 470μF 63V
P801-RESISTORS		
△ R801	4822 116 82032	1.2Ω ±5% ½W [A, E, W]
△ R802	5322 116 53479	1.2Ω ±5% ½W, Fusible [N, T]
△ R802	4822 113 90119	22Ω ±5% ¼W [A, E, W]
△ R803	4822 116 82032	22Ω ±2% ¼W, Fuse [N, T]
△ R803	4822 116 82032	1.2Ω ±5% ½W [A, E, W]
△ R804	5322 116 53479	1.2Ω ±5% ½W, Fusible [N, T]
△ R804	4822 113 90119	22Ω ±5% ¼W [A, E, W]
△ R804	4822 113 90119	22Ω ±2% ¼W, Fuse [N, T]

REF. DESIG.	PART NO.	DESCRIPTION		
		PU01-FUNCTION/ANA SWITCH CIRCUIT BOARD		
		PU01-CAPACITORS		
CU01	4822 124 90352	Elect	10 μ F	16V
CU03	4822 124 90351	Elect	0.1 μ F	50V
CU04	4822 124 90352	Elect	10 μ F	16V
CU07 } CU14		Ceramic	1000pF	\pm 10%
		PU01-SEMICONDUCTORS		
DU01 }	4822 130 80326	L.E.D.	LT3D8B RED 30	
DU06				
QU01	4822 209 71781	IC	TC9135P	
QU02	4822 209 70069	IC	TC9130P	
QU03 }	4822 130 61186	Transistor	DTA114TS, Digital	
QU06 QU07 }	4822 130 42594	Transistor	DTC144ES, Digital	
QU10				
QU11	4822 130 61189	Transistor	DTC114TS, Digital	
QU12	4822 130 61189	Transistor	DTC114TS, Digital	
		PU01-MISCELLANEOUS		
SU01 } SU06	4822 276 12455	Push Switch, Tact		
		PV01-PHONO AMP/INPUT SELECTOR CIRCUIT BOARD		
		PV01-CAPACITORS		
CV01 } CV10	4822 122 32486	Ceramic	0.01 μ F	+80% -20%
C401	4822 122 32486	Ceramic	0.01 μ F	+80% -20%
C402	4822 122 32486	Ceramic	0.01 μ F	+80% -20%
C403	4822 121 51037	Film	150pF	\pm 5% [A,E,T,W]
C404	4822 121 51037	Film	150pF	\pm 5% [A,E,T,W]
C405	4822 121 41518	Film	470pF	\pm 5%
C406	4822 121 41518	Film	470pF	\pm 5%
C407	4822 124 22279	Elect	510 μ F	10V
C408	4822 124 22279	Elect	510 μ F	10V
C409	4822 124 22278	Elect	51 μ F	10V
C410	4822 124 22278	Elect	51 μ F	10V
C411	4822 121 42764	Film	0.047 μ F	\pm 5%
C412	4822 121 42764	Film	0.047 μ F	\pm 5%
C413	4822 121 42755	Film	0.012 μ F	\pm 5%
C414	4822 121 42755	Film	0.012 μ F	\pm 5%
C415	4822 121 42758	Film	1800pF	\pm 5%
C416	4822 121 42758	Film	1800pF	\pm 5%
C417	4822 124 90358	Elect	22 μ F	16V
C418	4822 124 90358	Elect	22 μ F	16V
C419	4822 121 42763	Film	3900pF	\pm 5%
C420	4822 121 42763	Film	3900pF	\pm 5%
C421	4822 124 90365	Elect	220 μ F	25V
C422	4822 124 90365	Elect	220 μ F	25V

REF. DESIG.	PART NO.	DESCRIPTION		
		PV01-RESISTORS		
R405	4822 116 53691	4.64K Ω	\pm 1%	1/6W
R406	4822 116 53691	4.64K Ω	\pm 1%	1/6W
R407	4822 116 53691	4.64K Ω	\pm 1%	1/6W
R408	4822 116 53691	4.64K Ω	\pm 1%	1/6W
R419	4822 116 53691	4.64K Ω	\pm 1%	1/6W
R420	4822 116 53691	4.64K Ω	\pm 1%	1/6W
Δ R425	4822 113 90119	22 Ω	\pm 2%	1/4W, Fuse
Δ R426	4822 113 90119	22 Ω	\pm 2%	1/4W, Fuse
		PV01-SEMICONDUCTORS		
DV01 }	4822 130 33305	Diode	MA165, etc.	
DV05				
Q401	4822 130 42839	F.E.T.	2SK369(BL)	
Q402	4822 130 42839	F.E.T.	2SK369(BL)	
Q403	4822 130 42839	F.E.T.	2SK369(BL)	
Q404	4822 130 42839	F.E.T.	2SK369(BL)	
Q405	4822 209 73064	IC	NJM2068DD	
		PV01-MISCELLANEOUS		
JV01	4822 266 30282	Terminal, 2P; RCA		
JV02	4822 266 30285	Terminal, 6P; RCA		
JV03	4822 266 30284	Terminal, 4P; RCA		
		PV01-MISCELLANEOUS		
J401	4822 266 30282	Terminal, 2P; RCA		
		PV01-MISCELLANEOUS		
LV01 }	4822 280 20195	Relay	SZ-2104	
LV05				
L401	4822 156 11019	Choke Coil	320mH [N]	
L402	4822 156 11019	Choke Coil	320mH [N]	
SV01	4822 277 20832	Slide Switch, Input		
SV02	4822 277 21352	Slide Switch, Recout		
		PZ01-POWER/CLASS A INDICATOR CIRCUIT BOARD		
DZ01	4822 130 80326	L.E.D.	LT3D8B RED 30	
DZ02	4822 130 80326	L.E.D.	LT3D8B RED 30	
		P710-MAIN AMP CIRCUIT BOARD		
		P701-CAPACITORS		
CN01	4822 124 22274	Elect	4.7 μ F	50V
CN02	4822 124 41543	Elect	1 μ F	50V
CN04	4822 124 22276	Elect	47 μ F	50V
CN05	4822 124 22276	Elect	47 μ F	50V
C701	4822 124 23082	Elect	10 μ F	50V
C702	4822 124 23082	Elect	10 μ F	50V
C703	4822 121 43126	Film	120pF	\pm 5%
C704	4822 121 43126	Film	120pF	\pm 5%
C705	4822 124 23068	Elect	220 μ F	63V
C706	4822 124 23068	Elect	220 μ F	63V
C707		Film	68pF	\pm 10%
C708		Film	68pF	\pm 10%
C709	4822 121 51038	Film	220pF	\pm 5%
C710	4822 121 51038	Film	220pF	\pm 5%

REF. DESIG.	PART NO.	DESCRIPTION
P801-SEMICONDUCTORS		
△ D801	4822 130 32508	Diode DSF10C/RL103E
△ D802	4822 130 32508	Diode DSF10C/RL103E [N, T]
△ D803	4822 130 32508	Diode DSF10C/RL103E
△ D804	4822 130 32508	Diode DSF10C/RL103E [N, T]
△ D805	4822 130 32508	Diode DSF10C/RL103E
△ D806	4822 130 32508	Diode DSF10C/RL103E [N, T]
△ D807	4822 130 32508	Diode DSF10C/RL103E
△ D808	4822 130 32508	Diode DSF10C/RL103E [N, T]
△ D809	4822 130 32508	Diode DSF10C/RL103E
△ D810	4822 130 32508	Diode DSF10C/RL103E [N, T]
△ D811	4822 130 32508	Diode DSF10C/RL103E
△ D812	4822 130 32508	Diode DSF10C/RL103E [N, T]
△ D813	4822 130 32508	Diode DSF10C/RL103E
△ D814	4822 130 32508	Diode DSF10C/RL103E [N, T]
△ D815	4822 130 32508	Diode DSF10C/RL103E
△ D816	4822 130 32508	Diode DSF10C/RL103E [N, T]
△ Q801	4822 209 82829	IC NJM78M15FA
△ Q802	4822 209 61526	IC NJM79M15FA
△ Q803	4822 209 73873	IC NJM7824FA
P801-MISCELLANEOUS		
△ F801	4822 253 30201	Fuse 1A 250V
△ F802	4822 253 30201	Fuse 1A 250V
P851-MAIN AMP POWER SUPPLY CIRCUIT BOARD		
C851	4822 124 23067	Elect Cap. 18000 μ F/63V x 2
C852	4822 122 40545	Ceramic Cap. 0.01 μ F \pm 10%
D851	4822 130 33132	Diode D5FB20
D852	4822 130 33305	Diode MA165, etc.
L851	4822 280 20403	Relay MC24D2-0
P901-POWER SWITCH CIRCUIT BOARD		
△ C901	4822 122 33276	Ceramic Cap. 0.01 μ F \pm 20%
△ S901	4822 276 12647	Push Switch, Power
P951-FUSE/TRANSFORMER CIRCUIT BOARD		
△ F951	4822 253 30027	Fuse 3.15A 250V [A,N,T,W]
△ L001	4822 146 21453 4822 146 21454	Power Transformer [A, N, T, W] Power Transformer [E]

NOTE ON SAFETY:

Symbol Δ Fire or electrical shock hazard. Only original parts should be used to replace any part marked with symbol Δ . Any other component substitution (other than original type), may increase risk of fire or electrical shock hazard.



marantz®