

Service Manual

PM7000 /N1B, /N1G, /U1B
PM8000 /N1B, /N1G, /F1B, /F1N
Integrated amplifier

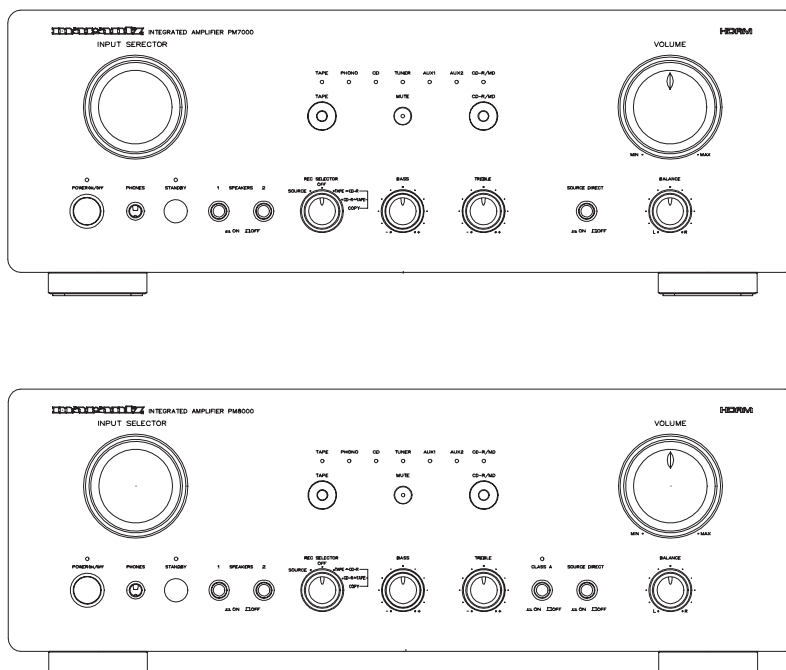

PM7000/8000

TABLE OF CONTENTS

SECTION	PAGE
1. SPECIFICATIONS	1
2. TEST EQUIPMENT REQUIRED SERVICING	2
3. IC INFORMATIONS	3
4. BLOCK DIAGRAM	5
5. WIRING DIAGRAM	7
6. SCHEMATIC DIAGRAM AND PARTS LOCATION (PARTS SIDE)	9
7. EXPLODED VIEW AND PARTS LIST	33
8. IDLING CURRENT AND DC OFFSET VOLTAGE ALIGNMENT	34
9. ELECTRICAL PARTS LIST	35

Please use this service manual with referring to the user guide (D.F.U) without fail.
修理の際は、必ず取扱説明書を準備し操作方法を確認の上作業を行って下さい。

marantz®

- PM7000 / PM8000 -

MARANTZ DESIGN AND SERVICE

Using superior design and selected high grade components, **MARANTZ** company has created the ultimate in stereo sound. Only original **MARANTZ** parts can insure that your **MARANTZ** product will continue to perform to the specifications for which it is famous.

Parts for your **MARANTZ** equipment are generally available to our National Marantz Subsidiary or Agent.

ORDERING PARTS :

Parts can be ordered either by mail or by Fax.. In both cases, the correct part number has to be specified.

The following information must be supplied to eliminate delays in processing your order :

1. Complete address
2. Complete part numbers and quantities required
3. Description of parts
4. Model number for which part is required
5. Way of shipment
6. Signature : any order form or Fax. must be signed, otherwise such part order will be considered as null and void.

USA

MARANTZ AMERICA, INC.
440 MEDINAH ROAD
ROSELLE, ILLINOIS 60172
USA
PHONE : 630 - 307 - 3100
FAX : 630 - 307 - 2687

EUROPE / TRADING

MARANTZ EUROPE B.V.
P.O.BOX 80002, BUILDING SFF2
5600 JB EINDHOVEN
THE NETHERLANDS
PHONE : +31 - 40 - 2732241
FAX : +31 - 40 - 2735578

BRAZIL

MARANTZ BRAZIL
CAIXA POSTAL 21462
CEP 04698-970
SAO PAULO, SP, BRAZIL
PHONE : 0800 - 123123(Discagem Direta Gratuita)
FAX : +55 11 534. 8988

PROFESSIONAL AMERICAS

SUPERSCOPE TECHNOLOGIES, INC.
MARANTZ PROFESSIONAL PRODUCTS
2640 WHITE OAK CIRCLE, SUITE A
AURORA, ILLINOIS 60504 USA
PHONE : 630 - 820 - 4800
FAX : 630 - 820 - 8103

CANADA

LENBROOK INDUSTRIES LIMITED
633 GRANITE COURT,
PICKERING, ONTARIO L1W 3K1
CANADA
PHONE : 905 - 831 - 6333
FAX : 905 - 831 - 6936

AUSTRALIA

JAMO AUSTRALIA PTY LTD
1 EXPO COURT, P.O. BOX 350
MT. WAVERLEY VIC 3149
AUSTRALIA
PHONE : +61 - 3 - 9543 - 1522
FAX : +61 - 3 - 9543 - 3677

THAILAND

MRZ STANDARD CO.,LTD
746 - 754 MAHACHAI ROAD.,
WANGBURAPAPIROM, PHRANAKORN,
BANGKOK, 10200 THAILAND
PHONE : +66 - 2 - 222 9181
FAX : +66 - 2 - 224 6795

SINGAPORE

WO KEE HONG (S) PTE LTD
WO KEE HONG CENTRE
NO.23, LORONG 8, TOA PAYOH
SINGAPORE 319257
PHONE : +65 2544555
FAX : +65 2502213

TAIWAN

PAI- YUING CO., LTD.
6 TH FL NO, 148 SUNG KIANG ROAD,
TAIPEI, 10429, TAIWAN R.O.C.
PHONE : +886 - 2 - 25221304
FAX : +886 - 2 - 25630415

MALAYSIA

WO KEE HONG ELECTRONICS SDN. BHD.
SUITE 8.1, LEVEL 8, MENARA GENESIS,
NO. 33, JALAN SULTAN ISMAIL,
50250 KUALA LUMPUR, MALAYSIA
PHONE : +60 3 - 2457677
FAX : +60 3 - 2458180

JAPAN *Technical*

MARANTZ JAPAN, INC.
35- 1, 7- CHOME, SAGAMIONO
SAGAMIHARA - SHI, KANAGAWA
JAPAN 228-8505
PHONE : +81 42 748 1013
FAX : +81 42 741 9190

日本マランツ株式会社

本社 〒228-8505
神奈川県相模原市相模大野7-35-1
営業本部 〒150-0022
東京都渋谷区恵比寿南1-11-9

KOREA

MK ENTERPRISES LTD.
ROOM 604/605, ELECTRO-OFFICETEL, 16-58,
3GA, HANGANG-RO, YONGSAN-KU, SEOUL
KOREA
PHONE : +822 - 3232 - 155
FAX : +822 - 3232 - 154

SHOCK, FIRE HAZARD SERVICE TEST :

CAUTION : After servicing this appliance and prior to returning to customer, measure the resistance between either primary AC cord connector pins (with unit NOT connected to AC mains and its Power switch ON), and the face or Front Panel of product and controls and chassis bottom.

Any resistance measurement less than 1 Megohms should cause unit to be repaired or corrected before AC power is applied, and verified before it is return to the user/customer.

Ref. UL Standard No. 1492.

In case of difficulties, do not hesitate to contact the Technical Department at above mentioned address.

1. SPECIFICATIONS

Power output (class AB operation)

RMS 8ohms (20 Hz - 20 kHz)	95W
DIN 8 ohms	105W
THD at 8 ohms RMS rated output	0.03%
Damping factor	150

Power out put (PM8000 classA operation)

RMS 8 ohms (20 Hz - 20 kHz)	25 W
DIN 8 ohms	28 W
THD at 8 ohms RMS. rated output	0.03%
Damping factor	130

IHF dynamic power (class AB operation)

8 ohms	120 W
--------------	-------

IHF dynamic power (PM8000 class A operation)

8 ohms	35 W
--------------	------

Magnetic cartridge input (MM)

input sensitivity impedance	2.5 mV/47 kOhms
Accuracy of frequency response to IEC RIAA	0.5 dB
Signal to noise ratio	85 dB

Tuner/CD/Aux/Tape inputs

input sensitivity impedance	150 mV/40 kOhms
Signal to noise ratio	109dB
Frequency response	
(-1 dB limits, Source Direct)	10 Hz - 50 kHz
Tone characteristic (100 Hz and 10 kHz)	±8 dB
Channel separation	
(1 kHz/10 kHz, Source direct)	>80 / >70 dB

General

Power Requirements

/N versions	230 V AC,50 Hz
/U versions	120 V AC,60 Hz

Dimensions

Width	440 mm
Height	159 mm
Depth	370.5 mm

Weight

Unit alone	12.3 kg
------------------	---------

Specifications subject to change without prior notice

定格出力(20 Hz - 20 kHz 両チャンネル同時駆動)

クラスAB.....95 W × 2 (8 Ω 負荷)

クラスA.....25 W × 2 (8 Ω 負荷)

全高周波歪率(20 Hz - 20 kHz, 10 W出力時8 Ω負荷)

クラスAB.....0.015%

クラスA.....0.010%

混変調歪率 (SMPTE).....0.015%

出力帯域幅 (8Ω負荷,0.08%歪率).....10 Hz - 80 kHz

周波数特性

(CD,ソースダイレクト).....10 Hz - 50 kHz +0 dB -1 dB

ダンピングファクター (8 Ω負荷,100 Hz - 10 kHz).....130

入力感度/入力インピーダンス

PHONO (MM).....2.5 mV/47 kΩ

HIGH LEVEL 150 mV/40 kΩ |

PHONO最大許容入力 (1 kHz)

(MM) 150 mV || RIAA偏差 (20 Hz)..... | -2 dB |
(40 Hz - 20 kHz).....	±0.5 dB
S/N比 (IHF,Aネットワーク,入力ショート)	
PHONO (MM).....	85 dB
HIGH LEVEL	109 dB
トーンコントロール	
BASS (100 Hz).....	±8 dB
TREBLE (10 kHz).....	±8 dB
電源電圧	AC 100 V, 50 Hz/60 Hz
消費電力 (電気用品取締法).....	160 W
最大外形寸法	
幅	440 mm
高さ	159 mm
奥行き	370.5 mm
質量	12.3 kg
付属品	
リモートコントロール送信機(RC8000PM).....	1台

本機の規格および外観は改良のため予告なく変更することがあります。

2.TEST EQUIPMENT REQUIRED FOR SERVICING

Item	Use
Distortion Analyzer	Distortion measurements
Audio Oscillator	Sinewave and squarewave signal source
AC VTVM	Voltage measurements (AC)
Oscilloscope	Waveform analysis and trouble shooting and ASO alignment
DC VTVM	Voltage measurements (DC)
AC Wattmeter	Monitors primary power to amplifier
Line Voltmeter	Monitors of primary voltage to amplifier
Variable Autotransformer	Adjust level of primary voltage to amplifier
Circuit Tester	Trouble shooting
Shorting Plug	Shorts amplifier input to eliminate noise pickup

項 目	使 用 方 法
歪 率 計	歪の測定
低 周 波 発 振 器	正弦波および矩形波の信号源
A C V T V M	交流電圧の測定
オシロスコープ	波計分析、トラブルシューティングおよびASOの調整
D C V T V M	直流電圧の測定
交流ワットメーター	アンプの一次側消費電力のモニター
電 源 電 圧 計	アンプの一次側電圧のモニター
ス ラ イ ダ ッ ク	アンプの一次側電圧の調整
テ ス タ ー	トラブルシューティング
ショート用プラグ	雑音を拾わないようにアンプ入力を短絡する

3. IC INFORMATIONS

MICROPROCESSOR TMP47C200BM BLOCK DIAGRAM

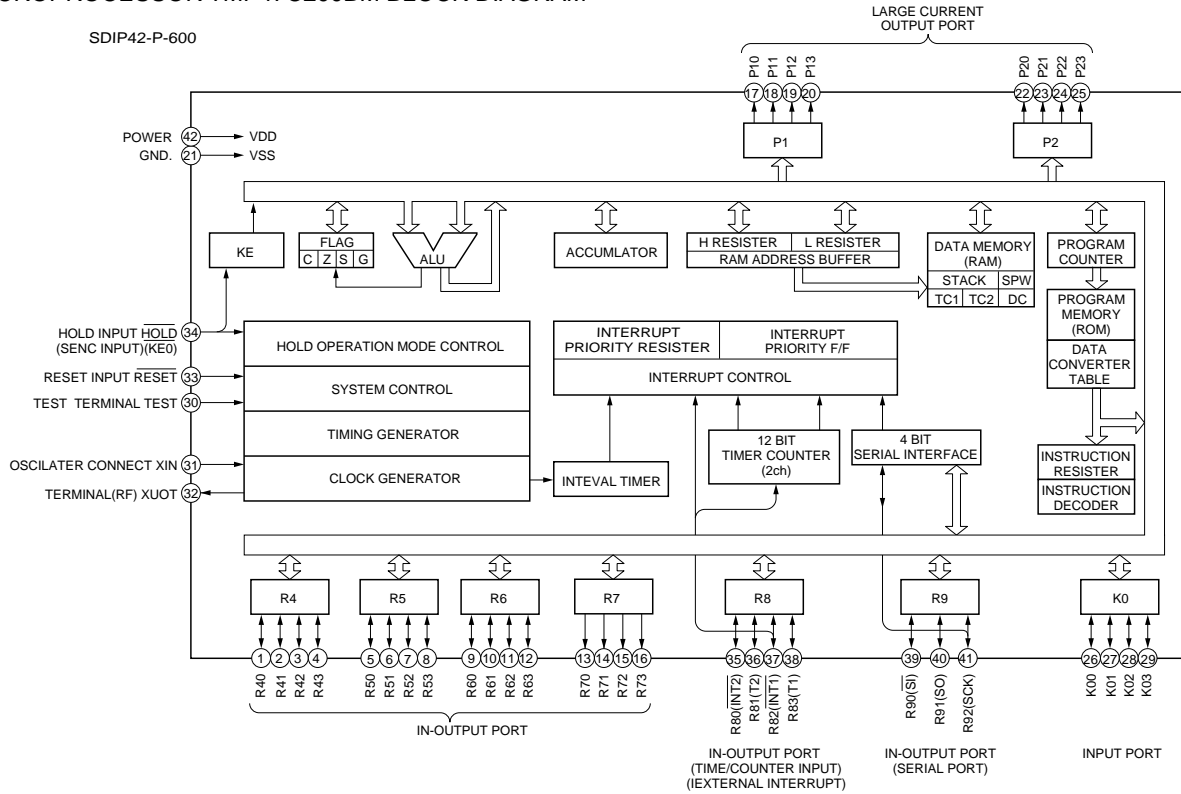

PIN no.	PORT NAME	ACT	FUNCTION
1	R40	MMUT	H MANUAL MUTE SIGNAL MUTE
2	R41	FMUT	L SIGNAL(SOURCE/MONITOR SWITCH)
3	R42	VOUP	L MOTOR DRIVE VOLUME UP
4	R43	VODW	L MOTOR DRIVE VOLUME DOWN
5	R50	T3K	L MONITOR INPUT SWITCH (TAPE3)
6	R51	T2K	L MONITOR INPUT SWITCH (TAPE2)
7	R52	T1K	L MONITOR INPUT SWITCH (TAPE1)
8	R53	AX2K	L SOURCE INPUT SWITCH (AUX2)
9	R60	AX1K	L SOURCE INPUT SWITCH (AUX1)
10	R61	TUNK	L SOURCE INPUT SWITCH (TUNER)
11	R62	CDK	L SOURCE INPUT SWITCH (CD)
12	R63	PHOK	L SOURCE INPUT SWITCH (PHONO)
13	R70	LSTB	L LED INDICATOR STAND BY DISPLAY
14	R71	LMUT	L LED INDICATOR MUTE DISPLAY
15	R72	LPRO	L LED INDICATOR PROCESSOR DISPLAY
16	R73	LTP3	L LED INDICATOR TAPE3 DISPLAY
17	P10	LTP2	L LED INDICATOR TAPE2 DISPLAY
18	P11	LTP1	L LED INDICATOR TAPE1 DISPLAY
19	P12	LSOU	L LED INDICATOR SOURCE DISPLAY
20	P13	LAX2	L LED INDICATOR AUX2 DISPLAY
21	VSS		GND.
22	P20	LAX1	L LED INDICATOR AUX1 DISPLAY
23	P21	LTUN	L LED INDICATOR TUNER DISPLAY
24	P22	LECD	L LED INDICATOR CD DISPLAY
25	P23	LPHO	L LED INDICATOR PHONO DISPLAY
26	K00	1RS	L SOURCE INPUT SWITCH(ROTARY ENCODER) bit1
27	K01	2RS	L SOURCE INPUT SWITCH(ROTARY ENCODER) bit2
28	K02	PRK	L PROCESSOR IN-OUT SWITCH
29	K03	MUK	L MANUAL MUTE
30	TEST		NOT USED (GND)
31	XIN		CLOCK 4.00 MHz (IN)
32	XOUT		CLOCK 4.00 MHz (OUT)
33	RESET	RES	L SYSTEM RESET
34	HOLD	PDW	L POWER DOWN CHECK
35	R80	RXRC	L REMOTE CONTROL INPUT (RC-5)
36	R81	EN1	MODEL SELECT 1
37	R82	EN2	MODEL SELECT 2
38	R83	EN3	MODEL SELECT 3
39	R90	TXRC	L SERIAL DATA(RC-5 REMOTE CONTROL)
40	R91	ENTX	L ENABLE (REMOTE CONTROL)
41	R92	RELY	L STAND-BY RELAY CONTROL
42	VDD		POWER SUPPLY

MICROPROCESSOR TMP47C200BM

Position NO.7401

SDIP42-P-600

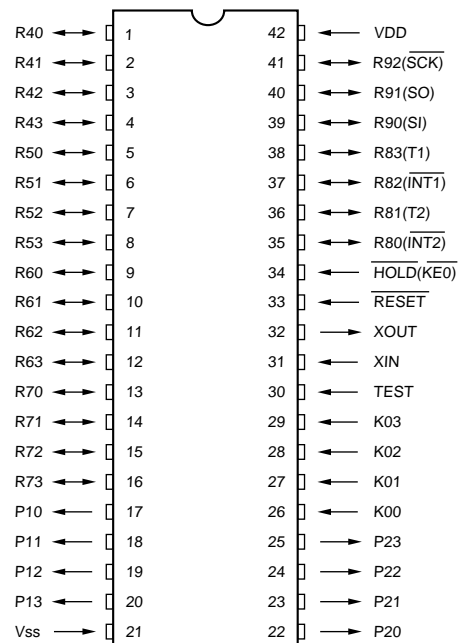

TA7317P (Position NO.7290)

TA7317P

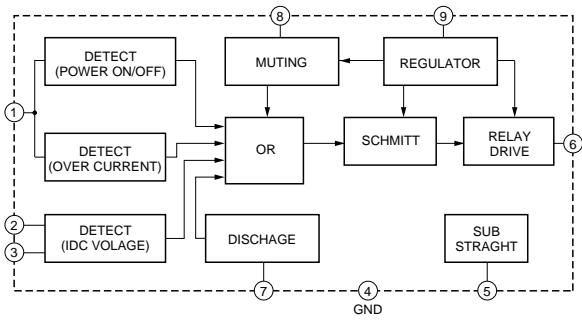
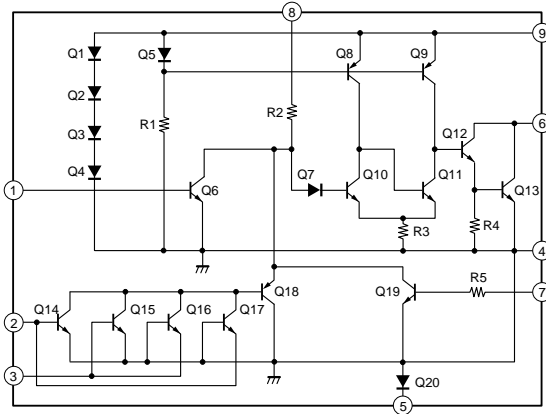
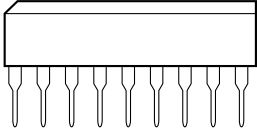

LB1641(Position NO.7402)

LB1641

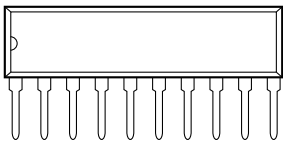

LB1641

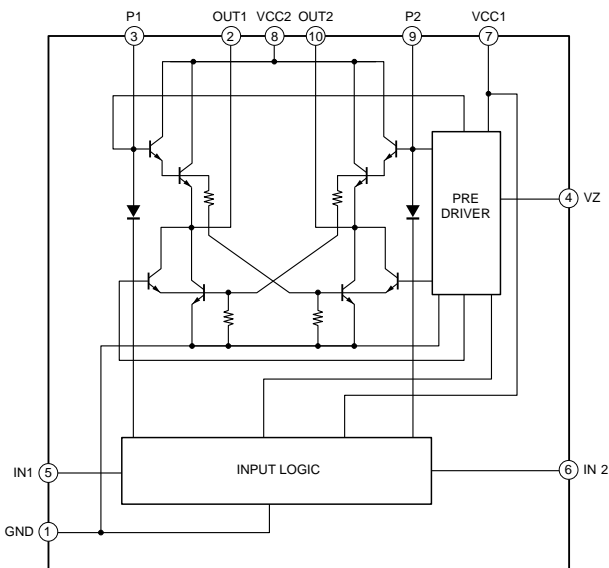

NJM2068 (Position NO.7501,7502,7503)

NJM2068

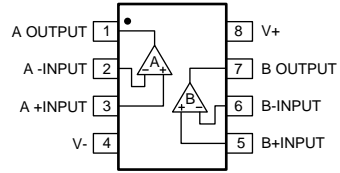

NJM2068

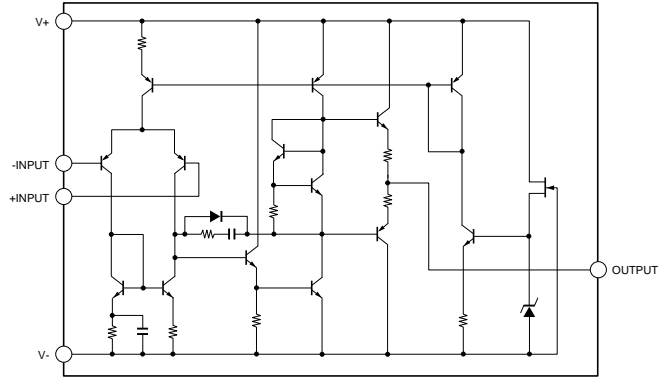

PC817 (Position NO.7269,7270)

PC817

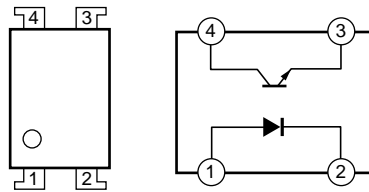

NJM2114(Position NO.7555,7655)

NJM2114

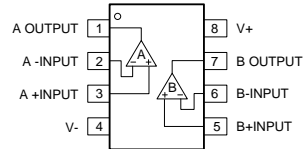

NJM2114

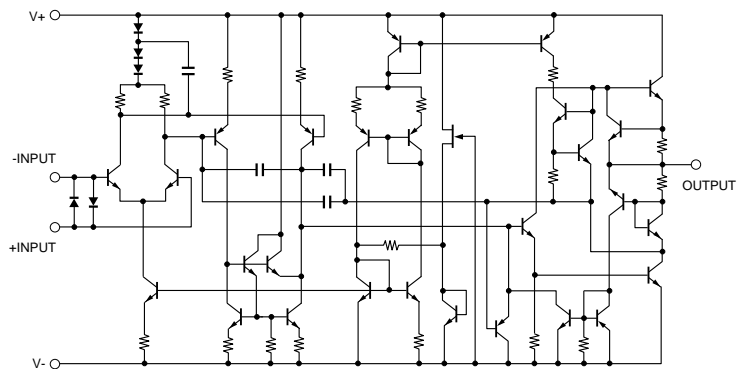

4. BLOCK DIAGRAM

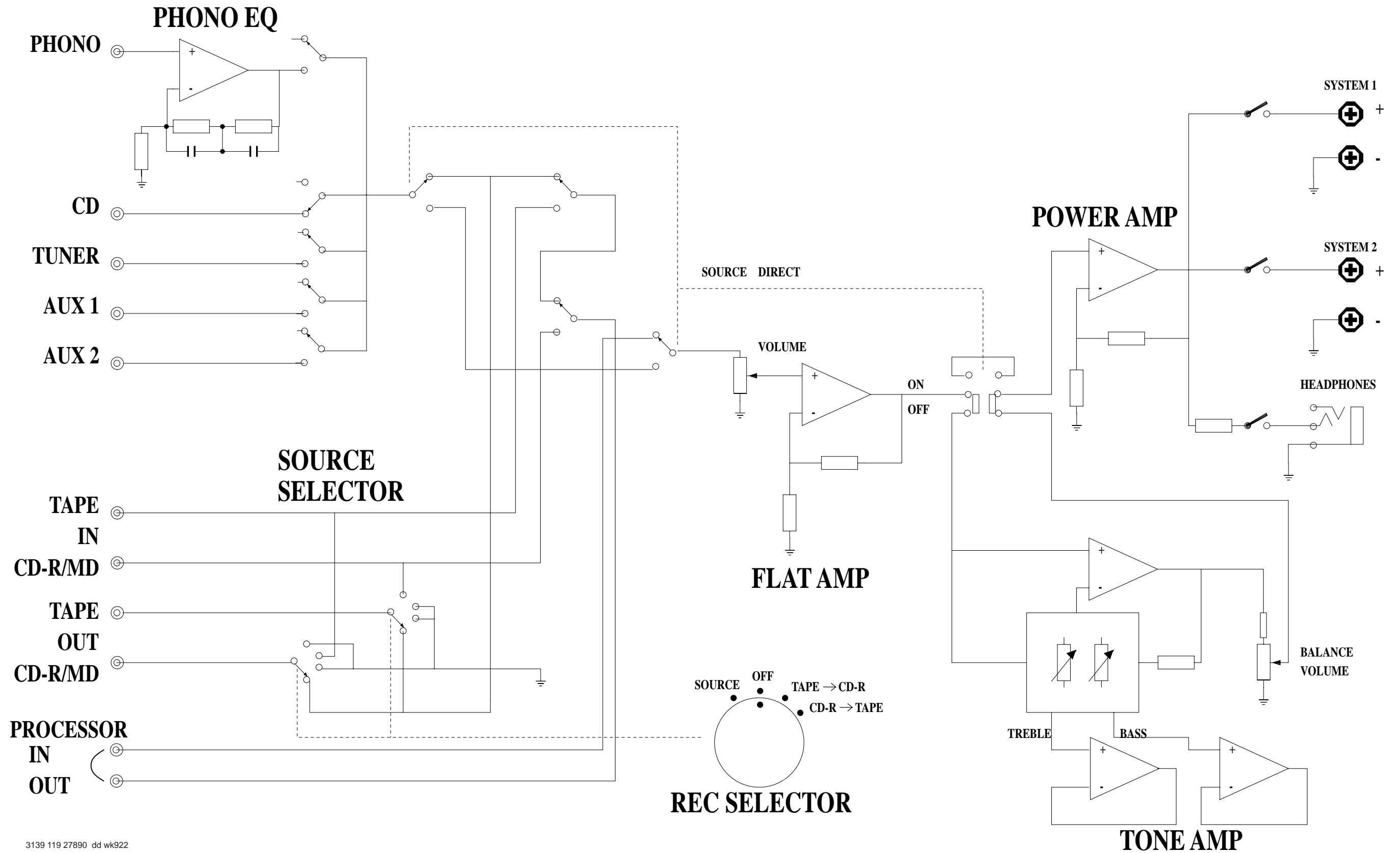

3139 119 27890 dd wk922

5. WIRING DIAGRAM

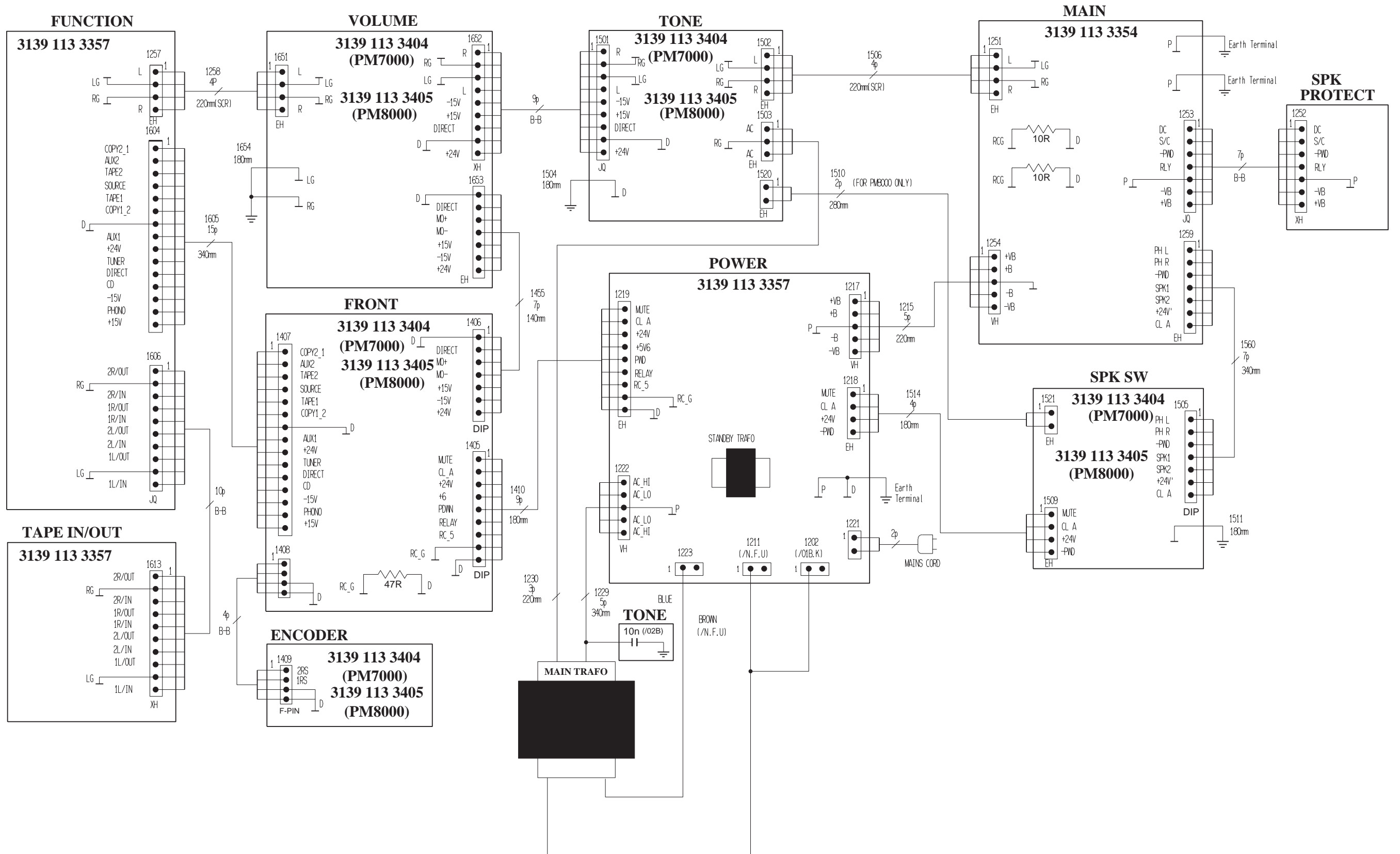

6. SCHEMATIC DIAGRAM AND PARTS LOCATION (PARTS SIDE)

FUNCTION & TAPE IN/OUT CIRCUIT

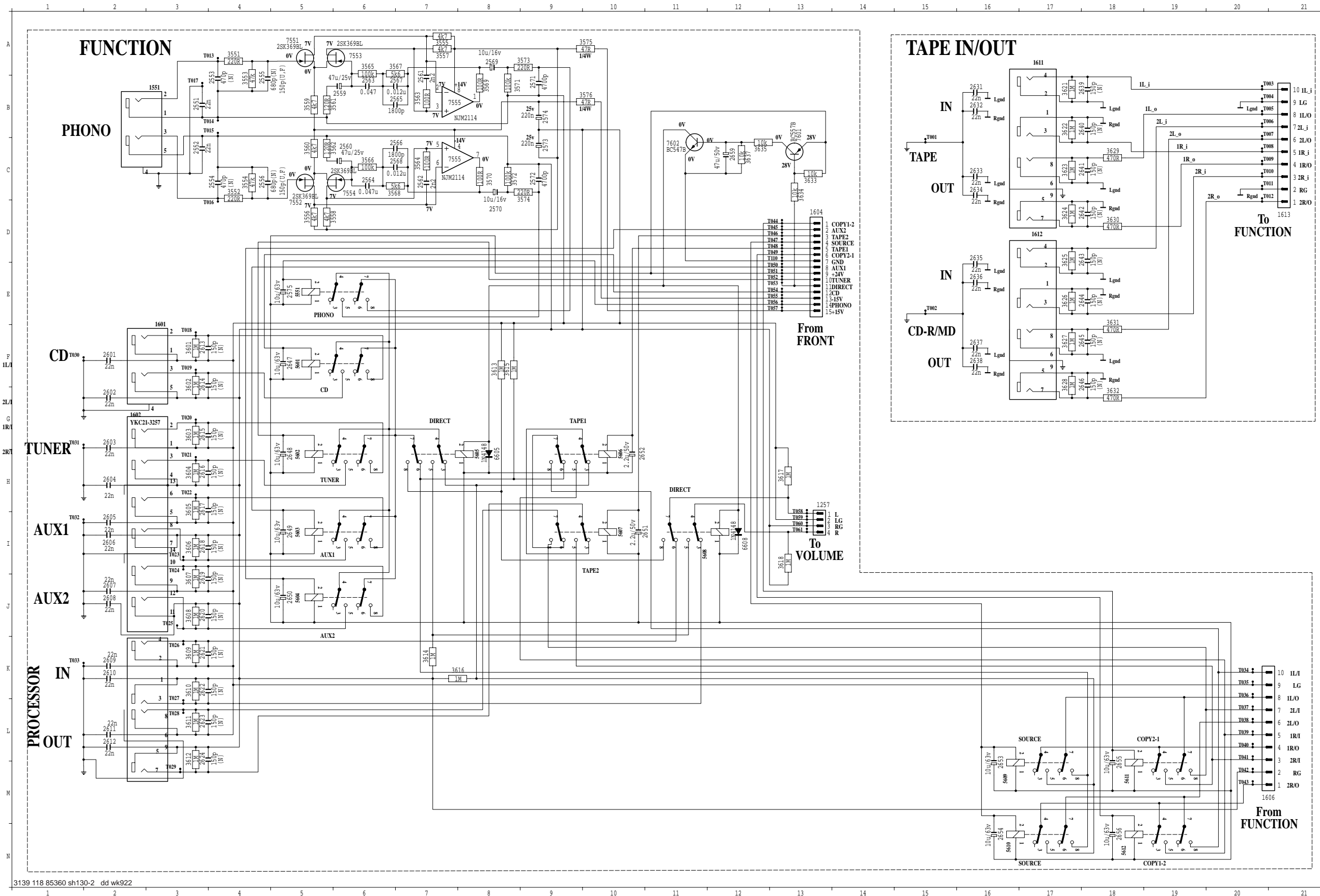

3139 118 85360 sh130-2 dd wk922

1257	1258	1259	1260	1261	1262	1263	1264	1265	1266	1267	1268	1269	1270	1271	1272	1273	1274	1275	1276	1277	1278	1279	1280	1281	1282	1283	1284	1285	1286	1287	1288	1289	1290	1291	1292	1293	1294	1295	1296	1297	1298	1299	1300	1301	1302	1303	1304	1305	1306	1307	1308	1309	1310	1311	1312	1313	1314	1315	1316	1317	1318	1319	1320	1321	1322	1323	1324	1325	1326	1327	1328	1329	1330	1331	1332	1333	1334	1335	1336	1337	1338	1339	1340	1341	1342	1343	1344	1345	1346	1347	1348	1349	1350	1351	1352	1353	1354	1355	1356	1357	1358	1359	1360	1361	1362	1363	1364	1365	1366	1367	1368	1369	1370	1371	1372	1373	1374	1375	1376	1377	1378	1379	1380	1381	1382	1383	1384	1385	1386	1387	1388	1389	1390	1391	1392	1393	1394	1395	1396	1397	1398	1399	1400	1401	1402	1403	1404	1405	1406	1407	1408	1409	1410	1411	1412	1413	1414	1415	1416	1417	1418	1419	1420	1421	1422	1423	1424	1425	1426	1427	1428	1429	1430	1431	1432	1433	1434	1435	1436	1437	1438	1439	1440	1441	1442	1443	1444	1445	1446	1447	1448	1449	1450	1451	1452	1453	1454	1455	1456	1457	1458	1459	1460	1461	1462	1463	1464	1465	1466	1467	1468	1469	1470	1471	1472	1473	1474	1475	1476	1477	1478	1479	1480	1481	1482	1483	1484	1485	1486	1487	1488	1489	1490	1491	1492	1493	1494	1495	1496	1497	1498	1499	1500
------	------	------	------	------	------	------	------	------	------	------	------	------	------	------	------	------	------	------	------	------	------	------	------	------	------	------	------	------	------	------	------	------	------	------	------	------	------	------	------	------	------	------	------	------	------	------	------	------	------	------	------	------	------	------	------	------	------	------	------	------	------	------	------	------	------	------	------	------	------	------	------	------	------	------	------	------	------	------	------	------	------	------	------	------	------	------	------	------	------	------	------	------	------	------	------	------	------	------	------	------	------	------	------	------	------	------	------	------	------	------	------	------	------	------	------	------	------	------	------	------	------	------	------	------	------	------	------	------	------	------	------	------	------	------	------	------	------	------	------	------	------	------	------	------	------	------	------	------	------	------	------	------	------	------	------	------	------	------	------	------	------	------	------	------	------	------	------	------	------	------	------	------	------	------	------	------	------	------	------	------	------	------	------	------	------	------	------	------	------	------	------	------	------	------	------	------	------	------	------	------	------	------	------	------	------	------	------	------	------	------	------	------	------	------	------	------	------	------	------	------	------	------	------	------	------	------	------	------	------	------	------	------	------	------	------	------	------	------	------	------	------	------	------

POWER CIRCUIT

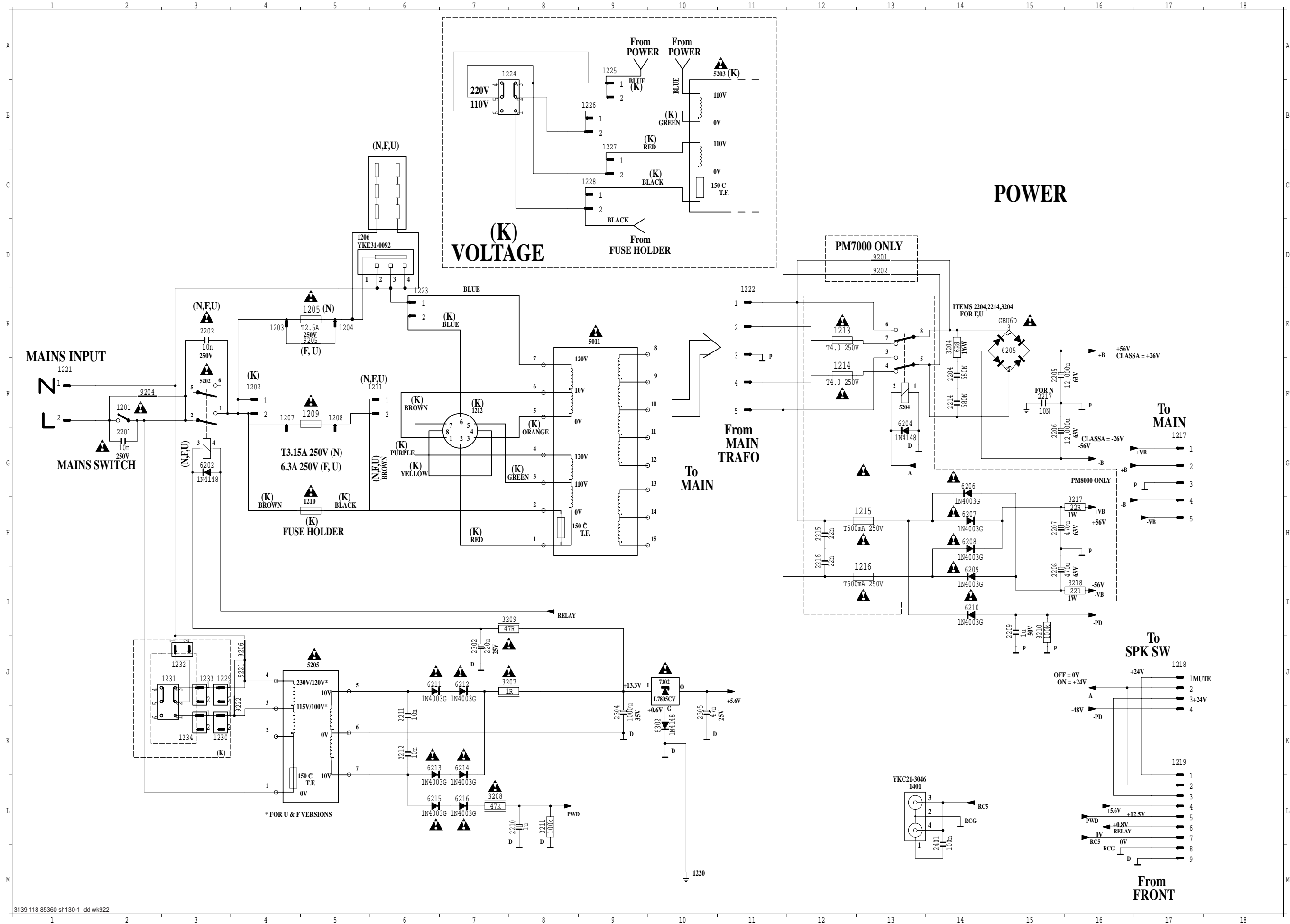

1203 P 2
1204 P 4
1205 P 4
1206 P 4
1207 P 4
1208 P 4
1209 P 4
1210 P 4
1211 P 4
1212 P 4
1213 P 4
1214 P 4
1215 P 4
1216 P 4
1217 P 4
1218 P 4
1219 P 4
1220 P 4
1221 P 4
1222 P 4
1223 P 4
1224 P 4
1225 P 4
1226 P 4
1227 P 4
1228 P 4
1229 P 4
1230 P 4
1231 P 4
1232 P 4
1233 P 4
1234 P 4
1235 P 4
1236 P 4
1237 P 4
1238 P 4
1239 P 4
1240 P 4
1241 P 4
1242 P 4
1243 P 4
1244 P 4
1245 P 4
1246 P 4
1247 P 4
1248 P 4
1249 P 4
1250 P 4
1251 P 4
1252 P 4
1253 P 4
1254 P 4
1255 P 4
1256 P 4
1257 P 4
1258 P 4
1259 P 4
1260 P 4
1261 P 4
1262 P 4
1263 P 4
1264 P 4
1265 P 4
1266 P 4
1267 P 4
1268 P 4
1269 P 4
1270 P 4
1271 P 4
1272 P 4
1273 P 4
1274 P 4
1275 P 4
1276 P 4
1277 P 4
1278 P 4
1279 P 4
1280 P 4
1281 P 4
1282 P 4
1283 P 4
1284 P 4
1285 P 4
1286 P 4
1287 P 4
1288 P 4
1289 P 4
1290 P 4
1291 P 4
1292 P 4
1293 P 4
1294 P 4
1295 P 4
1296 P 4
1297 P 4
1298 P 4
1299 P 4
1300 P 4

FRONT CIRCUIT

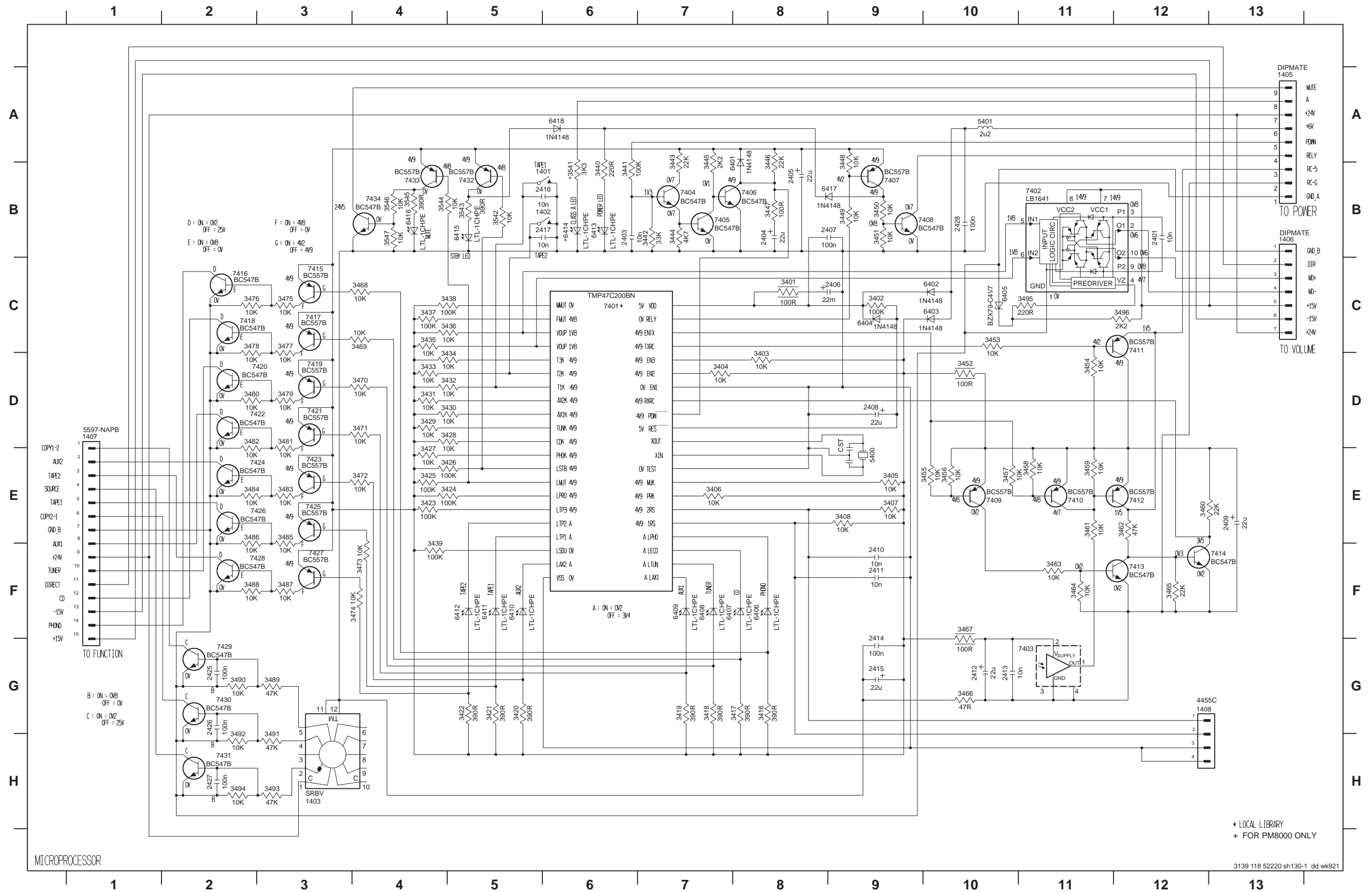

- 1401 B6
- 1402 B6
- 1403 H3
- 1405 A13
- 1406 B13
- 1407 D1
- 1408 G12
- 2401 B12
- 2403 B6
- 2404 B8
- 2405 B8
- 2406 C9
- 2407 B9
- 2408 D9
- 2409 E13
- 2410 F9
- 2411 F9
- 2412 G10
- 2413 G10
- 2414 G9
- 2415 G9
- 2416 B6
- 2417 B6
- 2425 G2
- 2426 C9
- 2427 H2
- 2428 B10
- 3401 C8
- 3402 C9
- 3403 D8
- 3404 D7
- 3405 E9
- 3406 E7
- 3407 E9
- 3408 E9
- 3415 G8
- 3417 G8
- 3418 G7
- 3419 G7
- 3420 G5
- 3421 G5
- 3422 G5
- 3423 E4
- 3424 E5
- 3425 E4
- 3426 E5
- 3427 E4
- 3428 D5
- 3429 D4
- 3430 D5
- 3431 D4
- 3432 D5
- 3433 D4
- 3434 D5
- 3435 D4
- 3436 C5
- 3437 C4
- 3438 C5
- 3439 F4
- 3440 B6
- 3441 B6
- 3442 B7
- 3443 B7
- 3444 B7
- 3445 B7
- 3446 B8
- 3447 B8
- 3448 B9
- 3449 B9
- 3450 B9
- 3451 B9
- 3452 D10
- 3453 C10
- 3454 D11
- 3455 E10
- 3456 E10
- 3457 E10
- 3458 E11
- 3459 E11
- 3460 E12
- 3461 E11
- 3462 E12
- 3463 F11
- 3464 F11
- 3465 F12
- 3466 G10
- 3467 F10
- 3468 C4
- 3469 C4
- 3470 D4
- 3471 D4
- 3472 E4
- 3473 F4
- 3474 F3
- 3475 C3
- 3476 C2
- 3477 C3
- 3478 C2
- 3479 D3
- 3480 D2
- 3481 D3
- 3482 D2
- 3483 E3
- 3484 E2
- 3485 E3
- 3486 E2
- 3487 F3
- 3488 F2
- 3489 G3
- 3490 G2
- 3491 H3
- 3492 H2
- 3493 H3
- 3494 H2
- 3495 C11
- 3496 C12
- 3541 B6
- 3542 B5
- 3543 B5
- 3544 B4
- 3545 B4
- 3546 B4
- 3547 B4
- 5400 E9
- 5401 A10
- 6401 B8
- 6402 C10
- 6403 C10
- 6404 C9
- 6405 C10
- 6406 F8
- 6407 F7
- 6408 F7
- 6409 F7
- 6410 F5
- 6411 F5
- 6412 F5
- 6413 B6
- 6414 B6
- 6415 B5
- 6416 B4
- 6417 B9
- 6418 A8
- 7401 G1
- 7402 B1
- 7403 G11
- 7404 B7
- 7405 B7
- 7406 B8
- 7407 B9
- 7408 B9
- 7409 E10
- 7410 E11
- 7411 C12
- 7412 E12
- 7413 F12
- 7414 F13
- 7415 C3
- 7416 C2
- 7417 C3
- 7418 C2
- 7419 D3
- 7420 D3
- 7421 D3
- 7422 D3
- 7423 E3
- 7424 E3
- 7425 E3
- 7426 E3
- 7427 F3
- 7428 F3
- 7429 G2
- 7430 G2
- 7431 H2
- 7432 B5
- 7433 B4
- 7434 B4

MICROPROCESSOR

* LOCAL LIBRARY
+ FOR PM8000 ONLY

3139 118 52220 sh130-1 dd wk921

MAIN CIRCUIT

1251	E 1	1258	E 21	2254	H 3	2262	H 7	2270	I 17	2278	K 15	325		326		3277		328		329		330		331		332		333		334		335		336		5269	F 18	6255	D 5	6263	G 6	6271	B 10	6279	F 18	7256	I 4	7264	I 7	7272	I 10	7280	H 13	7288	H 15
1252	F 116	1259	E 20	2255	H 3	2263	H 7	2271	I 17	2279	K 15	326		327		3278		329		330		331		332		333		334		335		336		5270	F 18	6256	D 5	6264	G 6	6272	B 10	6280	F 18	7257	I 4	7265	I 7	7273	I 10	7281	H 13	7289	H 15		
1253	F 120	1260	E 21	2256	H 3	2264	H 7	2272	I 17	2280	K 15	327		328		3279		330		331		332		333		334		335		336		5271	F 18	6257	D 5	6265	G 6	6273	B 10	6281	F 18	7258	I 4	7266	I 7	7274	I 10	7282	H 13	7290	H 15				
1254	F 124	1261	E 21	2257	H 3	2265	H 7	2273	I 17	2281	K 15	328		329		3280		331		332		333		334		335		336		5272	F 18	6258	D 5	6266	G 6	6274	B 10	6282	F 18	7259	I 4	7267	I 7	7275	I 10	7283	H 13	7291	H 15						
1255	F 130	1262	E 21	2258	H 3	2266	H 7	2274	I 17	2282	K 15	329		330		3281		332		333		334		335		336		5273	F 18	6259	D 5	6267	G 6	6275	B 10	6283	F 18	7260	I 4	7268	I 7	7276	I 10	7284	H 13	7292	H 15								
1256	F 134	1263	E 21	2259	H 3	2267	H 7	2275	I 17	2283	K 15	330		331		3282		333		334		335		336		5274	F 18	6260	D 5	6268	G 6	6276	B 10	6284	F 18	7261	I 4	7269	I 7	7277	I 10	7285	H 13	7293	H 15										
1257	F 140	1264	E 21	2260	H 3	2268	H 7	2276	I 17	2284	K 15	331		332		3283		334		335		336		5275	F 18	6261	D 5	6269	G 6	6277	B 10	6285	F 18	7262	I 4	7270	I 7	7278	I 10	7286	H 13	7294	H 15												
1258	F 144	1265	E 21	2261	H 3	2269	H 7	2277	I 17	2285	K 15	332		333		3284		335		336		5276	F 18	6262	D 5	6270	G 6	6278	B 10	6286	F 18	7263	I 4	7271	I 7	7279	I 10	7287	H 13	7295	H 15														
1259	F 150	1266	E 21	2262	H 3	2270	H 7	2278	I 17	2286	K 15	333		334		3285		336		337		5277	F 18	6263	D 5	6271	G 6	6279	B 10	6287	F 18	7264	I 4	7272	I 7	7280	I 10	7288	H 13	7296	H 15														
1260	F 154	1267	E 21	2263	H 3	2271	H 7	2279	I 17	2287	K 15	334		335		3286		337		338		5278	F 18	6264	D 5	6272	G 6	6280	B 10	6288	F 18	7265	I 4	7273	I 7	7281	I 10	7289	H 13	7297	H 15														
1261	F 160	1268	E 21	2264	H 3	2272	H 7	2280	I 17	2288	K 15	335		336		3287		338		339		5279	F 18	6265	D 5	6273	G 6	6281	B 10	6289	F 18	7266	I 4	7274	I 7	7282	I 10	7290	H 13	7298	H 15														
1262	F 164	1269	E 21	2265	H 3	2273	H 7	2281	I 17	2289	K 15	336		337		3288		339		340		5280	F 18	6266	D 5	6274	G 6	6282	B 10	6290	F 18	7267	I 4	7275	I 7	7283	I 10	7291	H 13	7299	H 15														
1263	F 170	1270	E 21	2266	H 3	2274	H 7	2282	I 17	2290	K 15	337		338		3289		340		341		5281	F 18	6267	D 5	6275	G 6	6283	B 10	6291	F 18	7268	I 4	7276	I 7	7284	I 10	7292	H 13	7300	H 15														
1264	F 174	1271	E 21	2267	H 3	2275	H 7	2283	I 17	2291	K 15	338		339		3290		341		342		5282	F 18	6268	D 5	6276	G 6	6284	B 10	6292	F 18	7269	I 4	7277	I 7	7285	I 10	7293	H 13	7301	H 15														
1265	F 180	1272	E 21	2268	H 3	2276	H 7	2284	I 17	2292	K 15	339		340		3291		342		343		5283	F 18	6269	D 5	6277	G 6	6285	B 10	6293	F 18	7270	I 4	7278	I 7	7286	I 10	7294	H 13	7302	H 15														
1266	F 184	1273	E 21	2269	H 3	2277	H 7	2285	I 17	2293	K 15	340		341		3292		343		344		5284	F 18	6270	D 5	6278	G 6	6286	B 10	6294	F 18	7271	I 4	7279	I 7	7287	I 10	7295	H 13	7303	H 15														
1267	F 190	1274	E 21	2270	H 3	2278	H 7	2286	I 17	2294	K 15	341		342		3293		344		345		5285	F 18	6271	D 5	6279	G 6	6287	B 10	6295	F 18	7272	I 4	7280	I 7	7288	I 10	7296	H 13	7304	H 15														
1268	F 194	1275	E 21	2271	H 3	2279	H 7	2287	I 17	2295	K 15	342		343		3294		345		346		5286	F 18	6272	D 5	6280	G 6	6288	B 10	6296	F 18	7273	I 4	7281	I 7	7289	I 10	7297	H 13	7305	H 15														
1269	F 200	1276	E 21	2272	H 3	2280	H 7	2288	I 17	2296	K 15	343		344		3295		346		347		5287	F 18	6273	D 5	6281	G 6	6289	B 10	6297	F 18	7274	I 4	7282	I 7	7290	I 10	7298	H 13	7306	H 15														
1270	F 204	1277	E 21	2273	H 3	2281	H 7	2289	I 17	2297	K 15	344		345		3296		347		348		5288	F 18	6274	D 5	6282	G 6	6290	B 10	6298	F 18	7275	I 4	7283	I 7	7291	I 10	7299	H 13	7307	H 15														
1271	F 210	1278	E 21	2274	H 3	2282	H 7	2290	I 17	2298	K 15	345		346		3297		348		349		5289	F 18	6275	D 5	6283	G 6	6291	B 10	6299	F 18	7276	I 4	7284	I 7	7292	I 10	7300	H 13	7308	H 15														
1272	F 214	1279	E 21	2275	H 3	2283	H 7	2291	I 17	2299	K 15	346		347		3298		349		350		5290	F 18	6276	D 5	6284	G 6	6292	B 10	6300	F 18	7277	I 4	7285	I 7	7293	I 10	7301	H 13	7309	H 15														
1273	F 220	1280	E 21	2276	H 3	2284	H 7	2292	I 17	2300	K 15	347		348		3299		350		351		5291	F 18	6277	D 5	6285	G 6	6293	B 10	6301	F 18	7278	I 4	7286	I 7	7294	I 10	7302	H 13	7310	H 15														

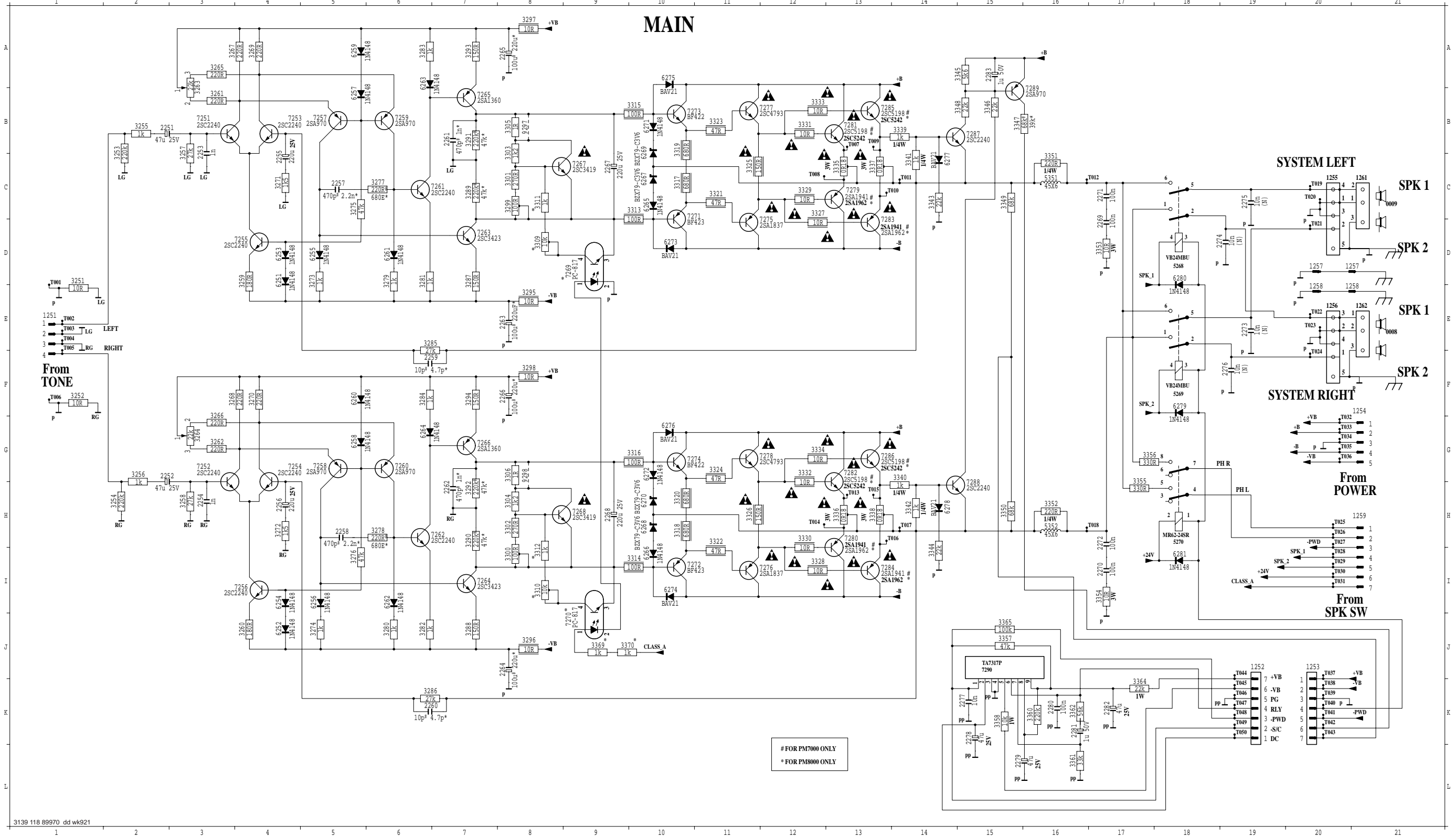

STONE CIRCUIT

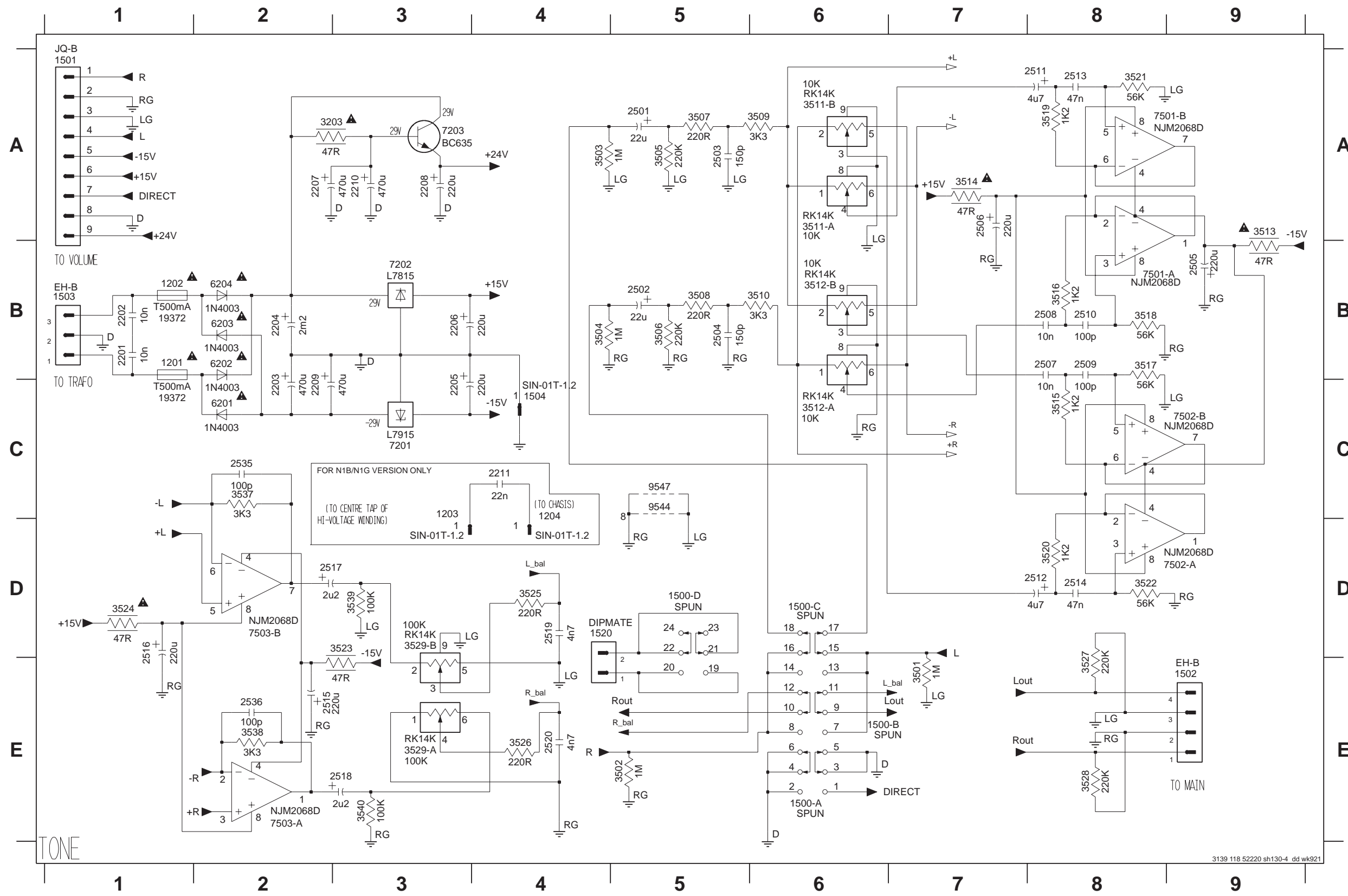

- 1201 B1
- 1202 B1
- 1203 C3
- 1204 C4
- 1500-A E6
- 1500-B E7
- 1500-C D6
- 1500-D D5
- 1501 A1
- 1502 E9
- 1503 B1
- 1504 C4
- 1520 D5
- 2201 B1
- 2202 B1
- 2203 C2
- 2204 B2
- 2205 C3
- 2206 B3
- 2207 A2
- 2208 A3
- 2209 C2
- 2210 A3
- 2211 C4
- 2501 A5
- 2502 B5
- 2503 A5
- 2504 B5
- 2505 B9
- 2506 A7
- 2507 B8
- 2508 B8
- 2509 B8
- 2510 B8
- 2511 A8
- 2512 D8
- 2513 A8
- 2514 D8
- 2515 E2
- 2516 D1
- 2517 D2
- 2518 E3
- 2519 D4
- 2520 E4
- 2535 C2
- 2536 E2
- 3203 A2
- 3501 E7
- 3502 E5
- 3503 A4
- 3504 B4
- 3505 A5
- 3506 B5
- 3507 A5
- 3508 B5
- 3509 A6
- 3510 B6
- 3511-A A6
- 3511-B A6
- 3512-A C6
- 3512-B B6
- 3513 A9
- 3514 A7
- 3515 C8
- 3516 B8
- 3517 B8
- 3518 B8
- 3519 A8
- 3520 D8
- 3521 A8
- 3522 D8
- 3523 D3
- 3524 D1
- 3525 D4
- 3526 E4
- 3527 E8
- 3528 E8
- 3529-A E3
- 3529-B D3
- 3537 C2
- 3538 E2
- 3539 D3
- 3540 E3
- 6201 C2
- 6202 B2
- 6203 B2
- 6204 B2
- 7201 C3
- 7202 B3
- 7203 A3
- 7501-A B8
- 7501-B A8
- 7502-A D8
- 7502-B C9
- 7503-A E2
- 7503-B D2
- 9544 C5
- 9547 C5

SPK SW CIRCUIT

1505 A1	1509 C4	1521 E4	3530 E2	3533 A2	6529 D1	9508 C2
1507-A B2	1510 A3	2533 A2	3531 E2	3534 A2	7529 D2	
1507-B B3	1511 E2	2534 A2	3532 D3	3535 D2	7530 D2	

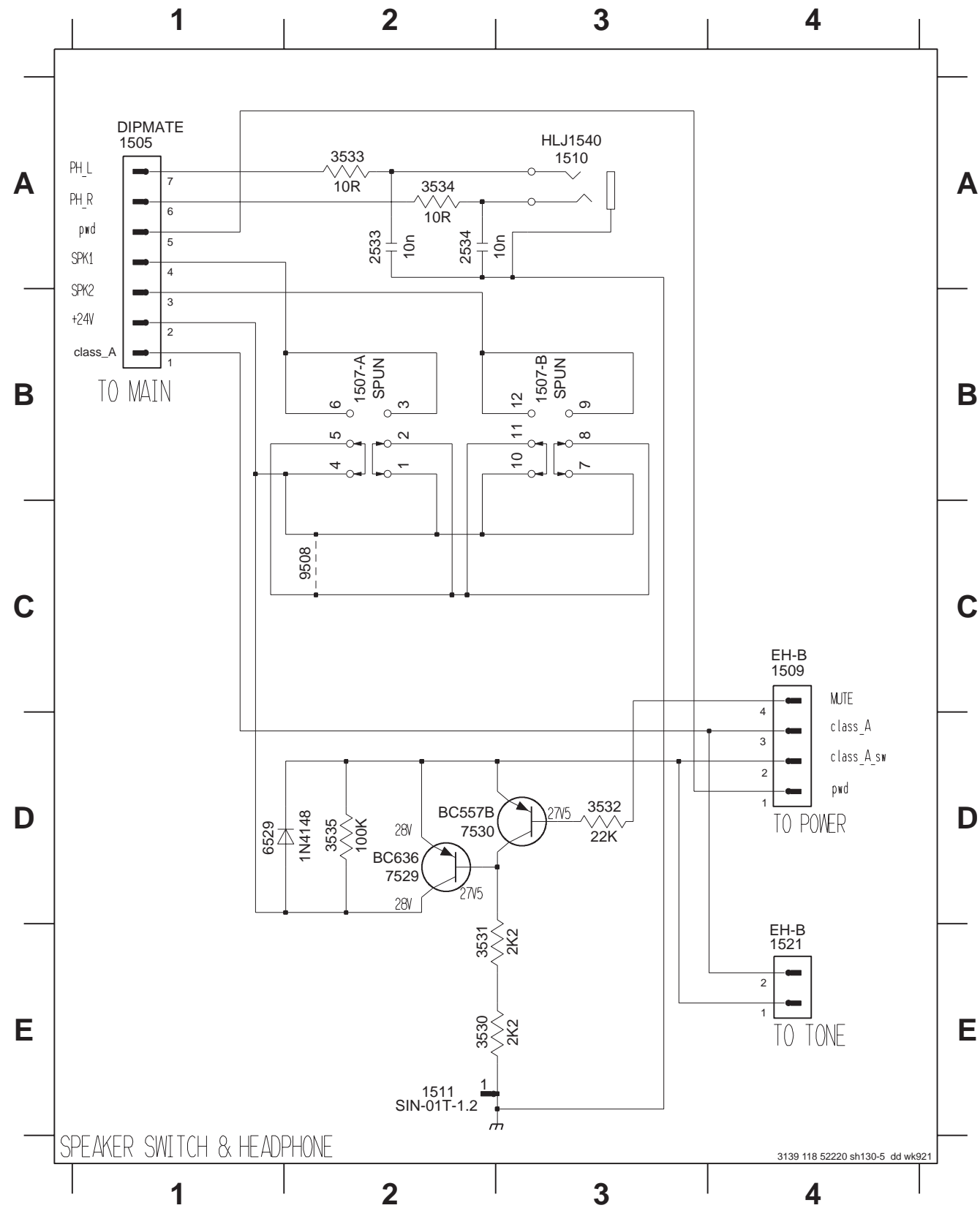

ENCODER CIRCUIT

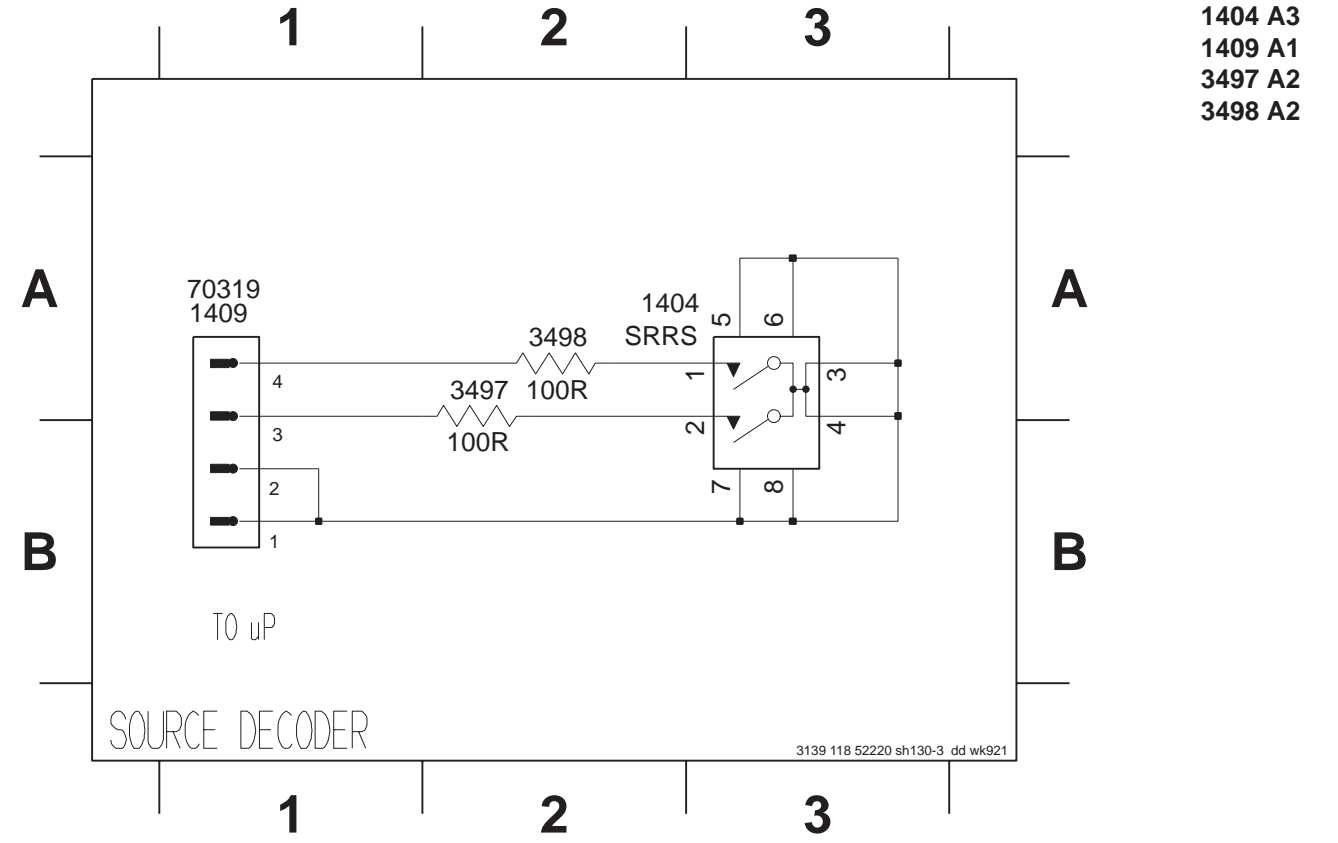

1404 A3
1409 A1
3497 A2
3498 A2

ENCODER BOARD

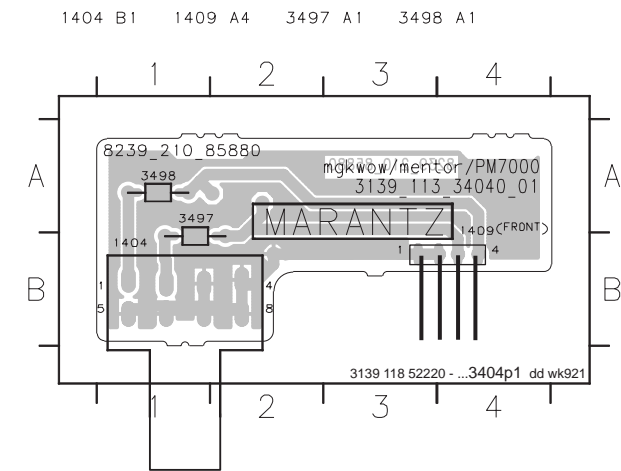

VOLUME CONTROL CIRCUIT (PM7000)

1651 B1	1655 D1	2654 D3	2658 C4	2662 D6	2666 C6	2670 C4	3653 A2	3657 B3	3661 A3	3665 B4	3669 B5	3673 B6	3681-A C2	7651 B3	7655-A D5
1652 B8	2651 A1	2655 B3	2659 A4	2663 B7	2667 A1	2671 A1	3654 D2	3658 C3	3662 D3	3666 D4	3670 D5	3674 D6	3681-B C2	7652 D3	7655-B B5
1653 A8	2652 D2	2656 D3	2660 D4	2664 D7	2668 A2	3651 B2	3655 B3	3659 A3	3663 B4	3667 C4	3671 B6	3675 A7	3681-C C2	7653 B4	
1654 D1	2653 B3	2657 B4	2661 B6	2665 C6	2669 B4	3652 D2	3656 D3	3660 D3	3664 D4	3668 C4	3672 D6	3676 A7	3681-D B1	7654 D4	

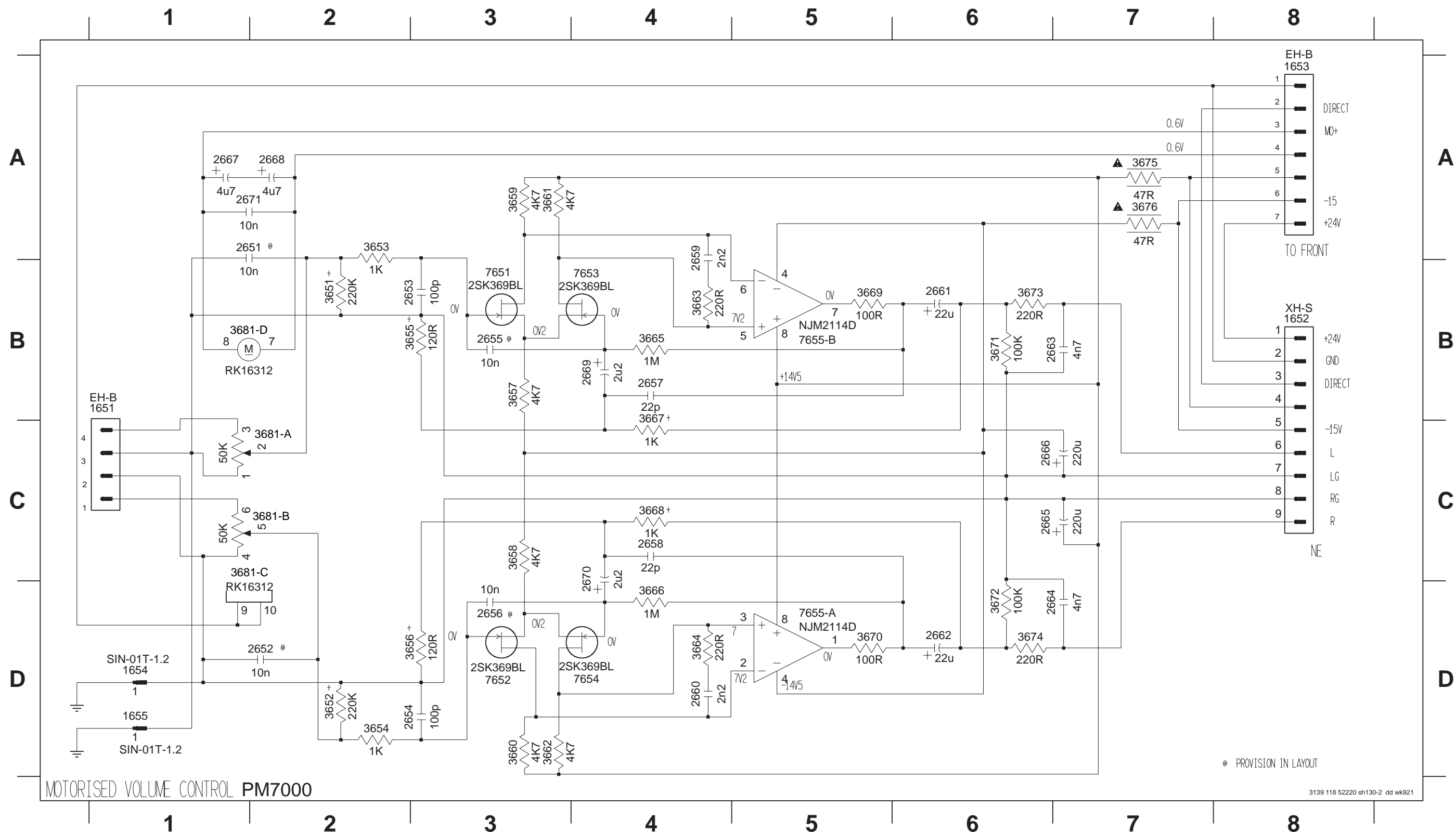

MOTORISED VOLUME CONTROL PM7000

⊗ PROVISION IN LAYOUT

3139 118 52220 sh130-2 dd wk921

VOLUME CONTROL CIRCUIT (PM8000)

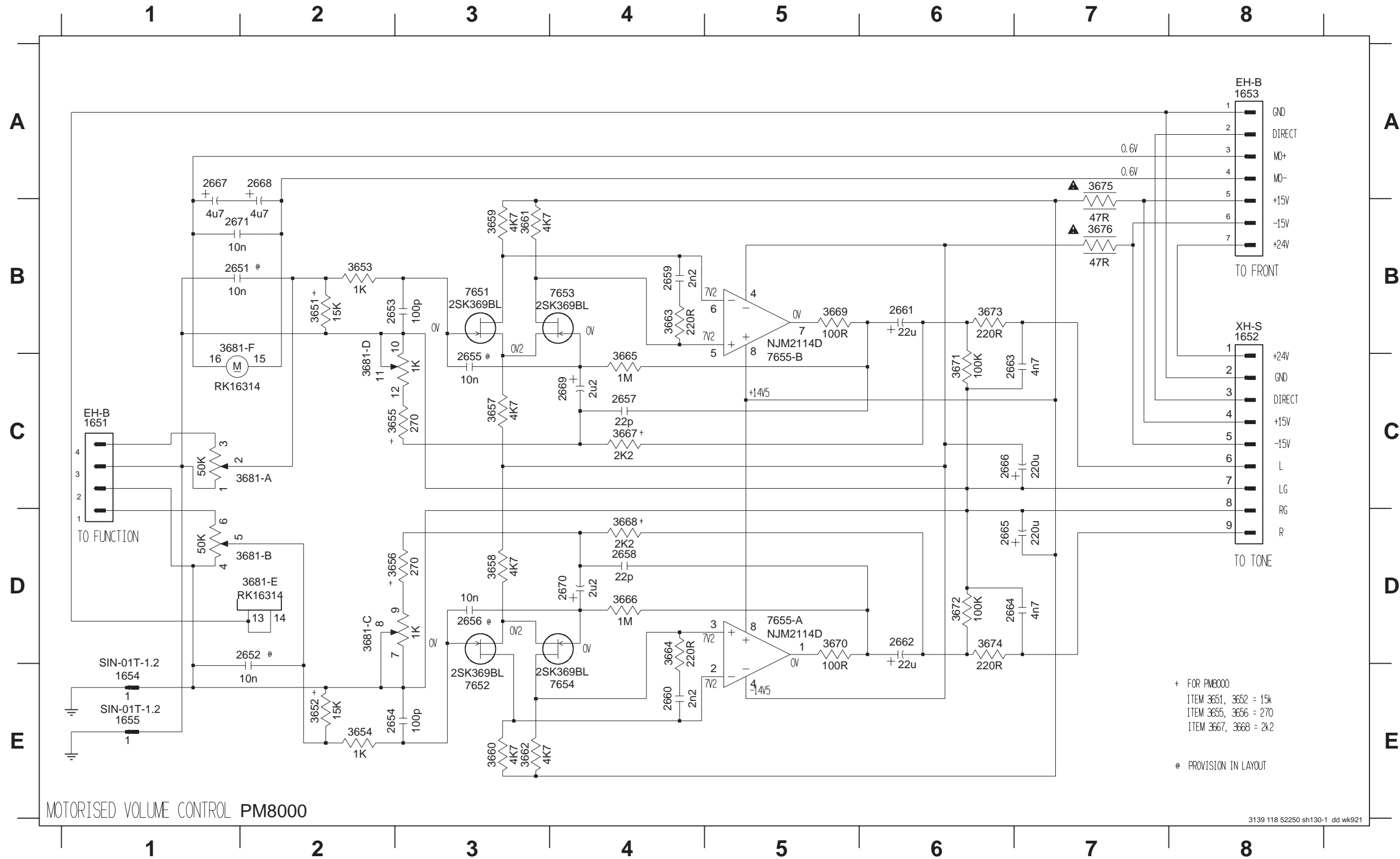

- 1651 C1
- 1652 B8
- 1653 A8
- 1654 E1
- 1655 E1
- 2651 B1
- 2652 D2
- 2653 B2
- 2654 E2
- 2655 C3
- 2656 D3
- 2657 C4
- 2658 D4
- 2659 B4
- 2660 E4
- 2661 B6
- 2662 D6
- 2663 C6
- 2664 D6
- 2665 D6
- 2666 C6
- 2667 A1
- 2668 A2
- 2669 C4
- 2670 D4
- 2671 B1
- 3651 B2
- 3652 E2
- 3653 B2
- 3654 E2
- 3655 C3
- 3656 D3
- 3657 C3
- 3658 D3
- 3659 B3
- 3660 E3
- 3661 B3
- 3662 E3
- 3663 B4
- 3664 D4
- 3665 C4
- 3666 D4
- 3667 C4
- 3668 D4
- 3669 B5
- 3670 D5
- 3671 C6
- 3672 D6
- 3673 B6
- 3674 D6
- 3675 A7
- 3676 B7
- 3681-A C1
- 3681-B D1
- 3681-C D2
- 3681-D C2
- 3681-E D2
- 3681-F B1
- 7651 B3
- 7652 E3
- 7653 B4
- 7654 E4
- 7655-A D5
- 7655-B B5
- T117 C1
- T118 C1
- T119 C1
- T120 C1
- T121 A8
- T122 A8
- T123 A8
- T124 A8
- T125 A8
- T126 B8
- T127 B8
- T128 B8
- T129 C8
- T130 C8
- T131 C8
- T132 C8
- T133 C8
- T134 C8
- T135 C8
- T136 D8

+ FOR PM8000
 ITEM 3651, 3652 = 15k
 ITEM 3655, 3656 = 270
 ITEM 3667, 3668 = 2k2
 * PROVISION IN LAYOUT

MOTORISED VOLUME CONTROL PM8000

3139 118 52250 sh130-1 dd wk921

FUNCTION & TAPE IN / OUT & POWER BOARD

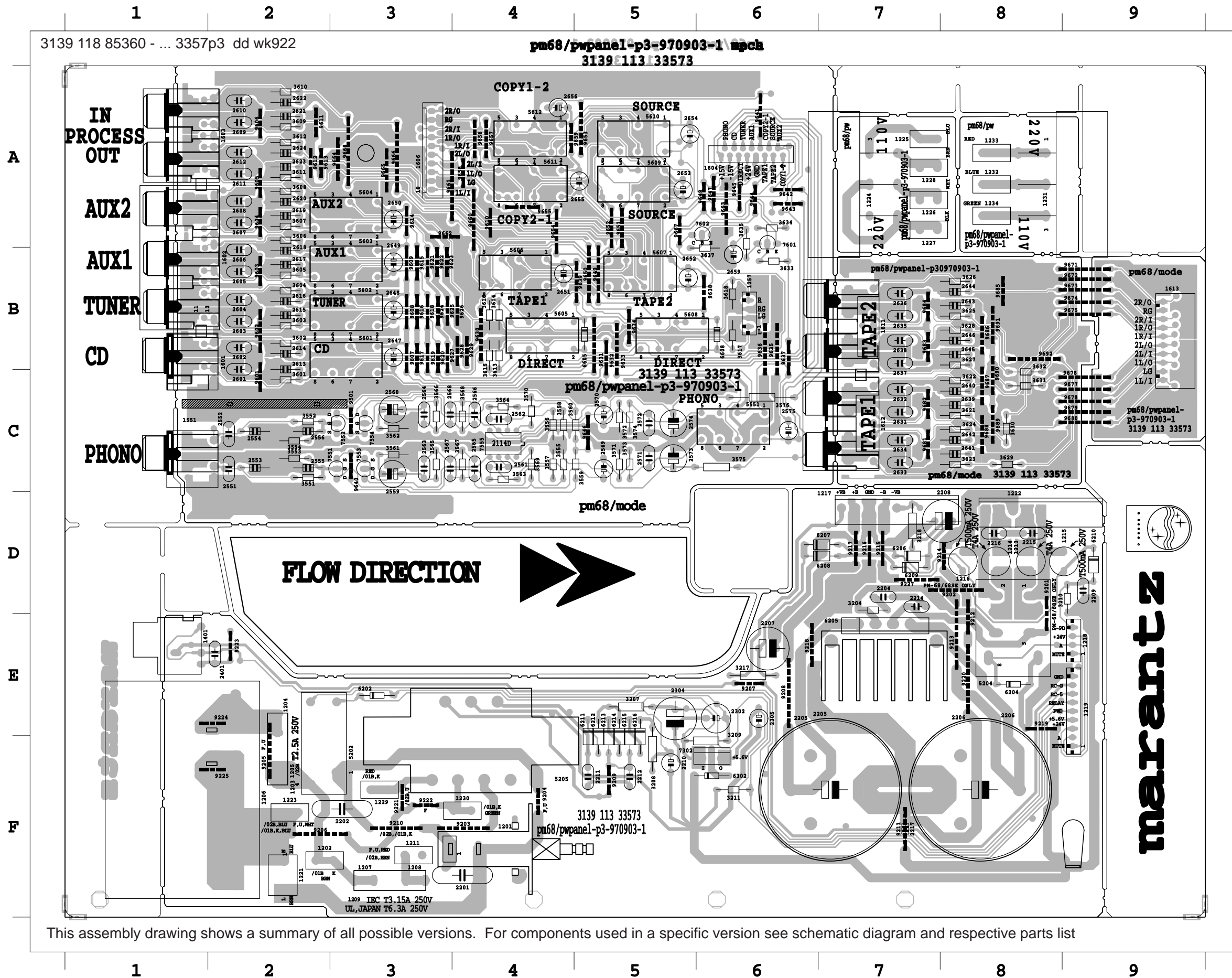

1257	B	6	3562	C	3	9624	B	3	1232	A	8
1551	C	1	3563	C	4	9625	B	3	1233	A	8
1601	B	1	3564	C	4	9626	B	4	1234	A	8
1602	B	1	3565	C	3	9627	B	3	1401	E	1
1603	A	1	3566	C	3	9628	B	4	2201	F	4
1604	A	6	3567	C	4	9629	B	4	2202	F	3
1606	A	3	3568	C	4	9630	B	4	2204	D	7
1611	B	7	3569	C	4	9631	B	5	2205	F	7
1612	C	7	3570	C	4	9632	B	5	2206	F	8
1613	B	9	3571	C	5	9633	B	5	2207	E	6
2551	C	2	3572	C	5	9634	B	5	2208	D	8
2552	C	2	3573	C	5	9635	B	6	2209	D	9
2553	C	2	3574	C	5	9636	B	6	2210	F	5
2554	C	2	3575	C	6	9637	B	6	2211	F	5
2555	C	2	3576	C	6	9638	B	6	2212	F	5
2556	C	2	3601	C	2	9639	B	5	2214	D	7
2559	C	3	3602	B	2	9640	C	3	2215	D	8
2560	C	3	3603	B	2	9641	A	6	2216	D	8
2561	C	4	3604	B	2	9642	A	6	2217	F	7
2562	C	4	3605	B	2	9643	A	6	2302	E	6
2563	C	3	3606	A	2	9644	A	6	2304	E	5
2564	C	3	3607	A	2	9645	A	6	2305	E	6
2565	C	4	3608	A	2	9646	C	5	2401	E	2
2566	C	4	3609	A	2	9647	A	6	3204	D	7
2567	C	3	3610	A	2	9648	A	6	3207	E	5
2568	C	3	3611	A	2	9649	B	5	3208	F	6
2569	C	5	3612	A	2	9650	B	5	3209	F	5
2570	C	5	3613	B	4	9651	A	5	3210	D	9
2571	C	5	3614	B	4	9652	A	5	3211	F	6
2572	C	5	3615	B	4	9653	A	5	3212	E	6
2573	C	5	3616	B	4	9654	A	4	3218	D	7
2574	C	5	3617	B	6	9655	A	4	5202	F	2
2575	C	6	3618	B	6	9656	A	4	5204	E	8
2601	C	2	3621	C	8	9657	A	4	6202	C	3
2602	B	2	3622	C	8	9658	A	4	6204	E	8
2603	B	2	3623	C	8	9659	A	4	6205	E	7
2604	B	2	3624	C	8	9660	A	4	6206	D	7
2605	B	2	3625	B	8	9661	A	3	6207	D	7
2606	B	2	3626	B	8	9662	A	3	6208	D	7
2607	A	2	3627	B	8	9663	A	6	6209	D	7
2608	A	2	3628	B	8	9664	A	3	6210	D	9
2609	A	2	3629	C	8	9665	A	3	6211	F	5
2610	A	2	3630	C	8	9666	A	3	6212	F	5
2611	A	2	3631	C	8	9667	A	5	6213	F	5
2612	A	2	3632	C	8	9668	A	3	6214	F	5
2613	C	2	3633	B	6	9671	B	9	6215	F	5
2614	B	2	3634	A	6	9672	B	9	6216	F	5
2615	B	2	3635	A	6	9673	B	9	6302	F	6
2616	B	2	3637	B	6	9674	B	9	7302	F	8
2617	B	2	5551	C	6	9675	B	9	9201	E	8
2618	B	2	5601	B	3	9676	C	9	9202	D	8
2619	A	2	5602	B	3	9677	C	9	9203	F	4
2620	A	2	5603	B	3	9678	C	9	9204	F	4
2621	A	2	5604	A	3	9679	C	9	9205	F	2
2622	A	2	5605	B	4	9680	C	9	9206	F	2
2623	A	2	5606	B	4	9681	C	7	9207	E	6
2624	A	2	5607	B	5	9682	C	7	9208	E	6
2631	C	7	5608	B	5	9683	B	7	9209	F	3
2632	C	7	5609	A	5	9684	B	7	9210	F	3
2633	C	7	5610	A	5	9685	B	8	9211	F	7
2634	C	7	5611	A	4	9686	B	8	9212	E	8
2635	B	7	5612	A	4	9687	C	8	9213	E	8
2636	B	7	6605	B	5	9688	C	8	9214	D	8
2637	B	7	6608	B	6	9689	C	8	9215	D	7
2638	B	7	7551	C	3	9690	C	8	9216	D	7
2639	C	8	7552	C	3	9691	B	8	9217	D	7
2640	C	8	7553	C	3	9692	B	8	9218	E	6
2641	C	8	7554	C	3	---	---	---	9219	E	8
2642	C	8	7555	C	4	---	---	---	9220	E	8
2643	B	8	7601	A	6	1201	F	3	9221	F	3
2644	B	8	7602	A	6	1202	F	2	9222	F	3
2645	B	8	9501	C	3	1203	F	2	9223	E	2
2646	B	8	9601	C	2	1204	F	2	9224	E	2
2647	B	3	9602	B	2	1206	F	2	9225	F	2
2648	B	3	9603	B	2	1207	F	3	9227	D	7
2649	B	3	9604	A	2	1208	F	3	---	---	---
2650	A	3	9605	A	2	1211	F	3	---	---	---
2651	B	4	9606	A	2	1213	D	8	---	---	---
2652	B	5	9607	B	3	1214	D	8	---	---	---
2653	A	5	9608	B	3	1215	D	9	---	---	---
2654	A	5	9609	B	3	1216	D	8	---	---	---
2655	A	5	9610	A	4	1217	D	7	---	---	---
2656	A	4	9611	A	2	1218	E	9	---	---	---
2659	B	6	9612	A	2	1219	E	9	---	---	---
3551	C	2	9613	A	2	1221	F	2	---	---	---
3552	C	2	9614	A	3	1222	D	8	---	---	---
3553	C	2	9615	B	3	1223	F	2	---	---	---
3554	C	2	9616	B	3	1224	A	7	---	---	---
3555	C	4	9617	B	3	1225	A	7	---	---	---
3556	C	4	9618	B	3	1226	A	7	---	---	---
3557	C	4	9619	B	3	1227	A	7	---	---	---
3558	C	4	9620	B	3	1228	A	7	---	---	---
3559	C	5	9621	B	3	1229	F	3	---	---	---
3560	C	5	9622	B	3	1230	F	4	---	---	---
3561	C	3	9623	B	3	1231	A	8	---	---	---

This assembly drawing shows a summary of all possible versions. For components used in a specific version see schematic diagram and respective parts list

1 TONE BOARD (PM7000)

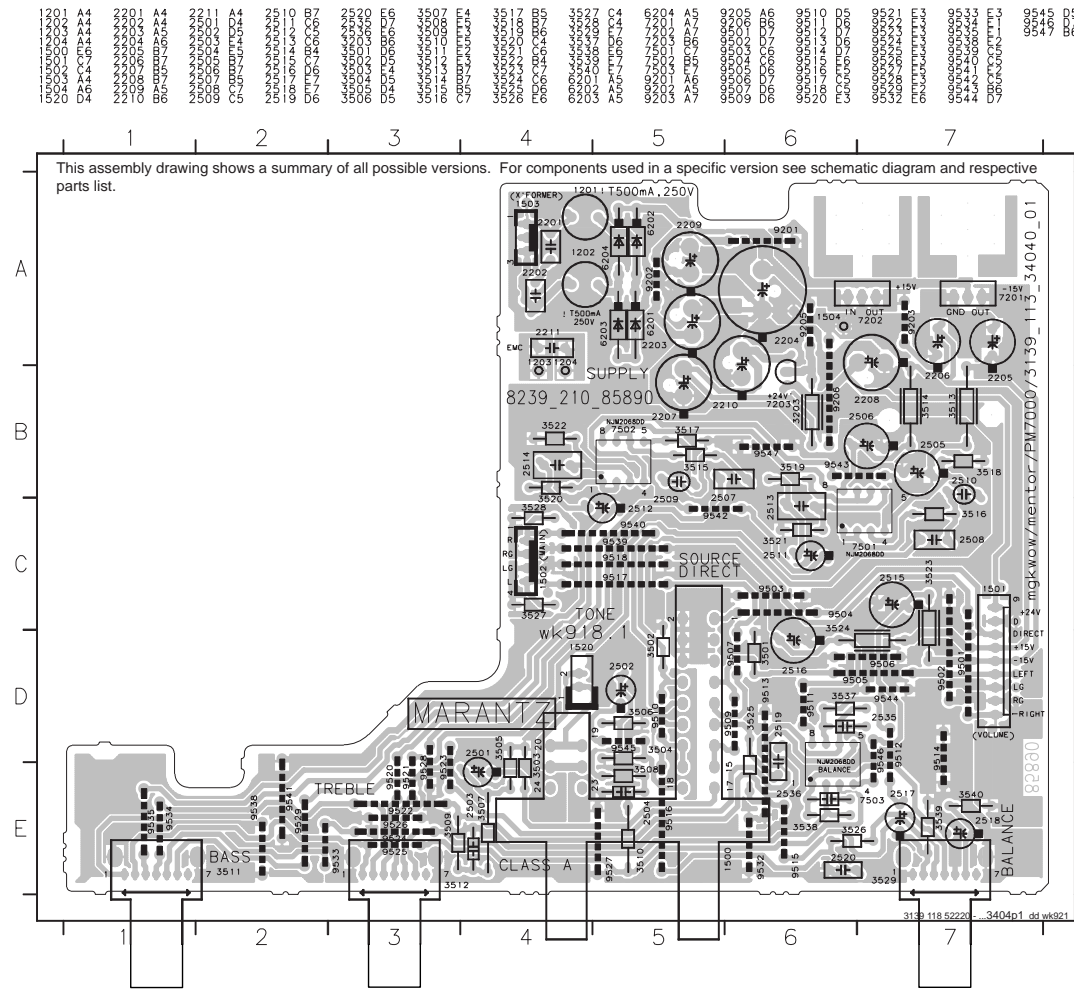

2 TONE BOARD (PM8000)

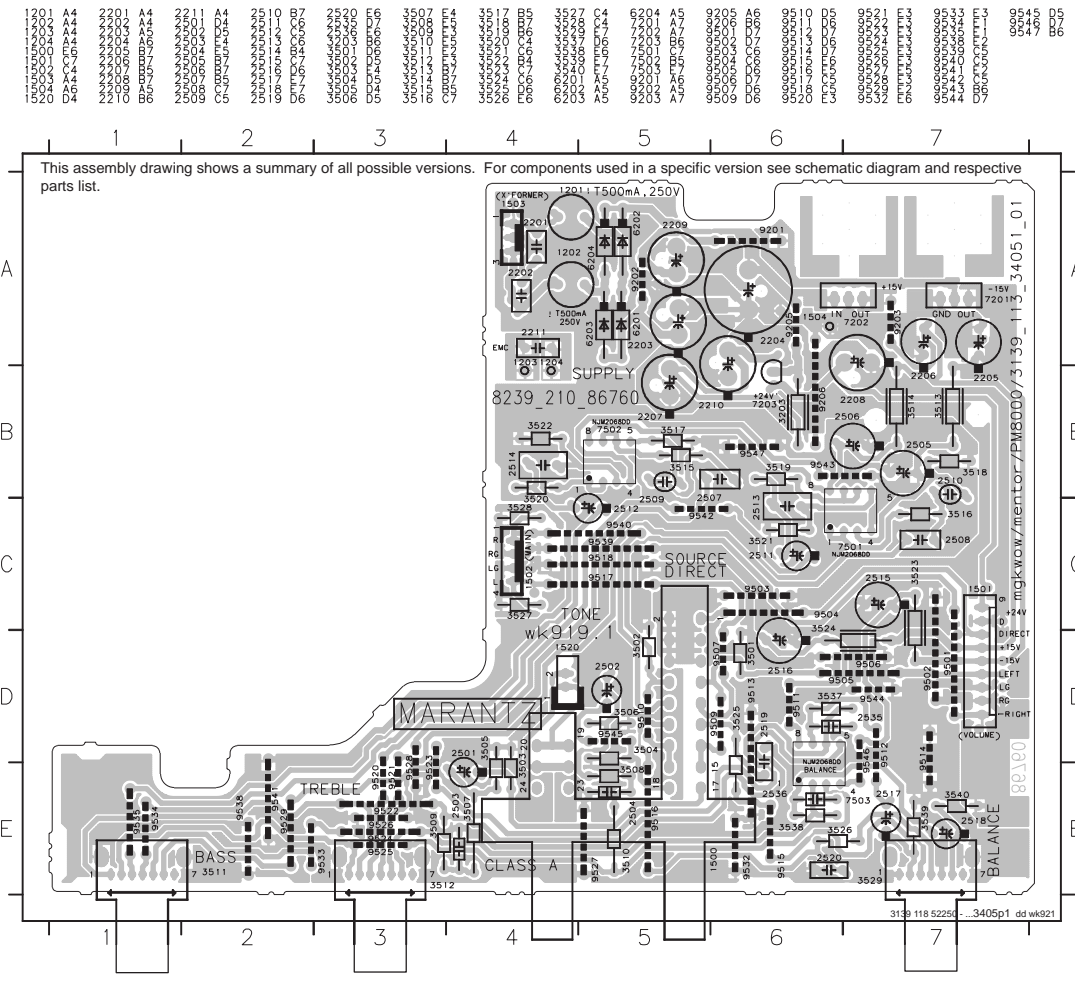

3 FRONT BOARD

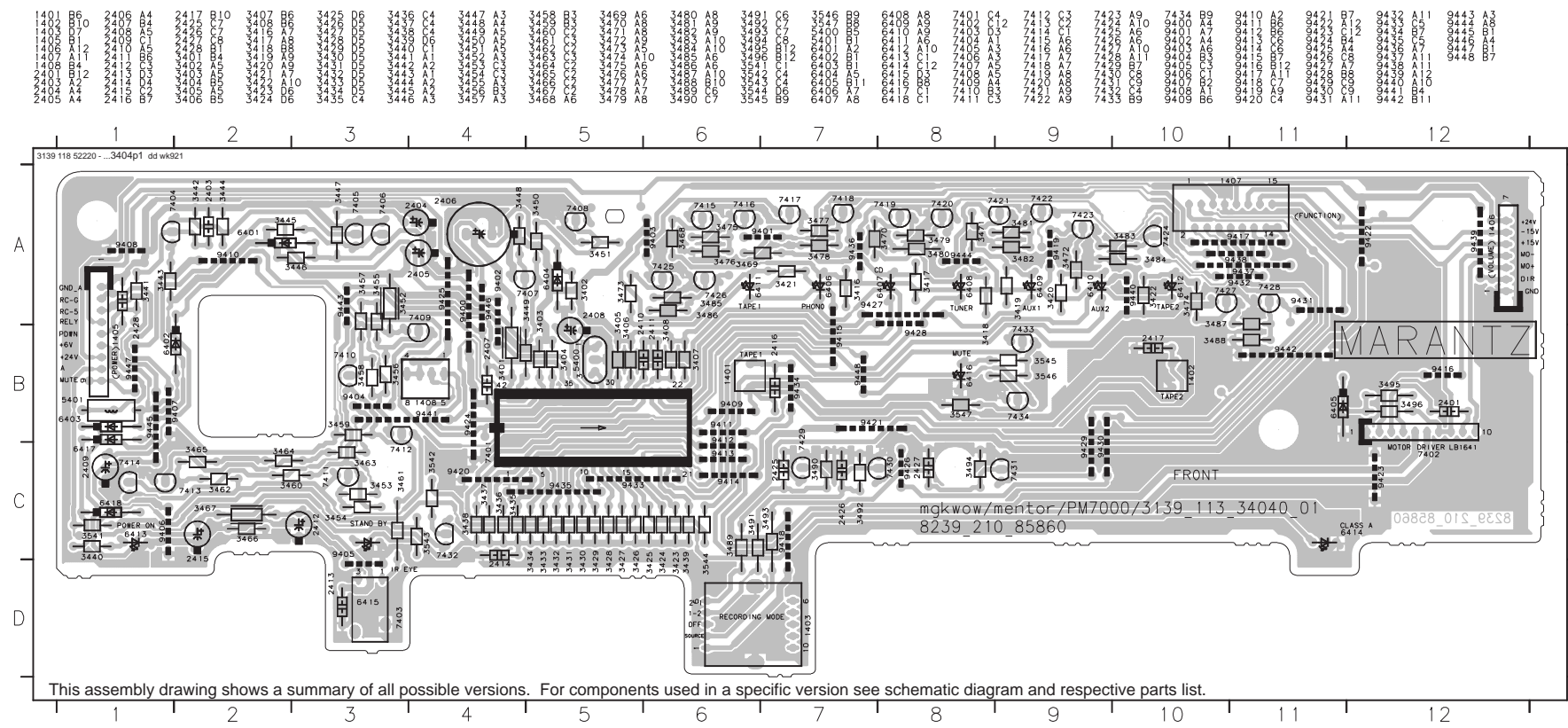

4 SPK SW BOARD

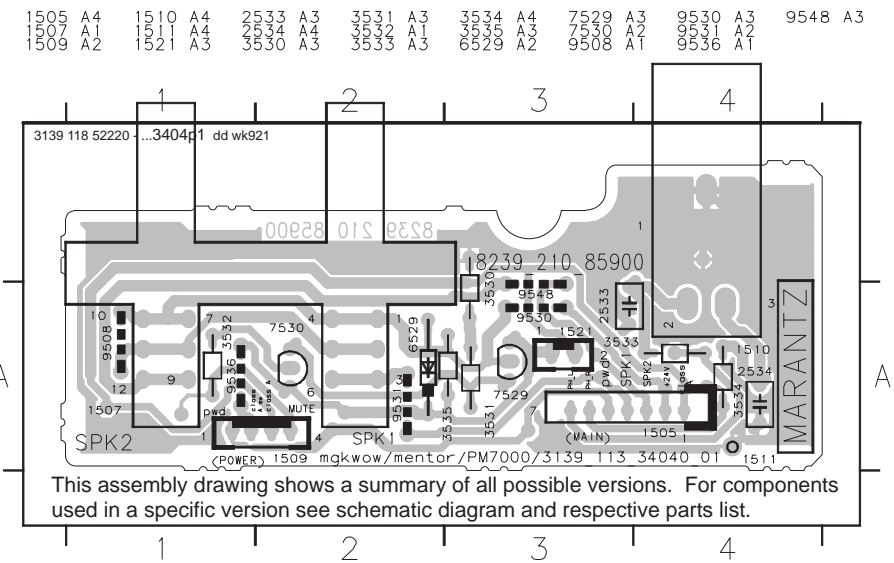

VOLUME BOARD (PM7000)

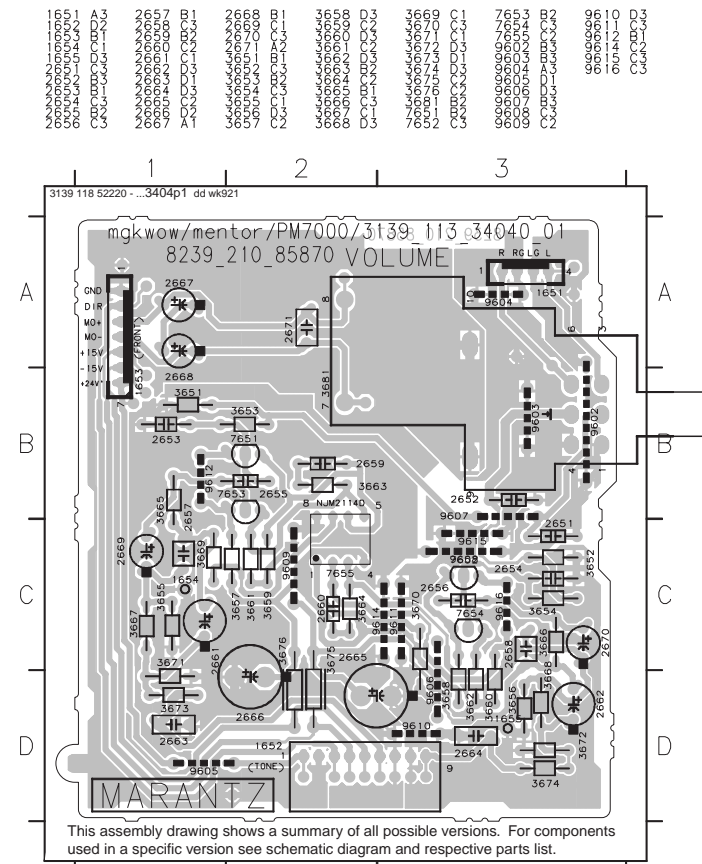

VOLUME BOARD (PM8000)

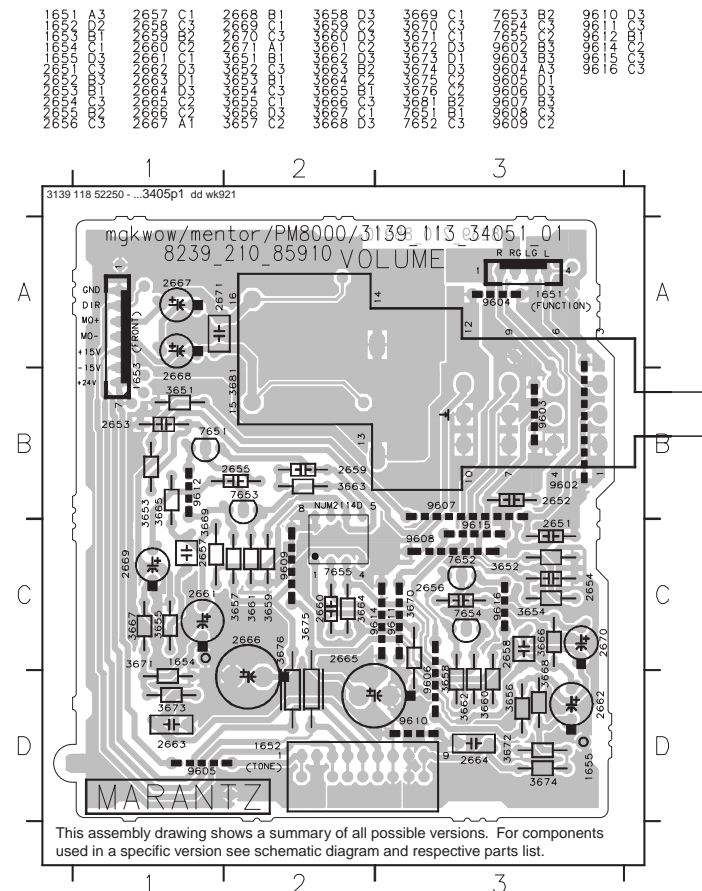

MAIN & SP PROTECT BOARD

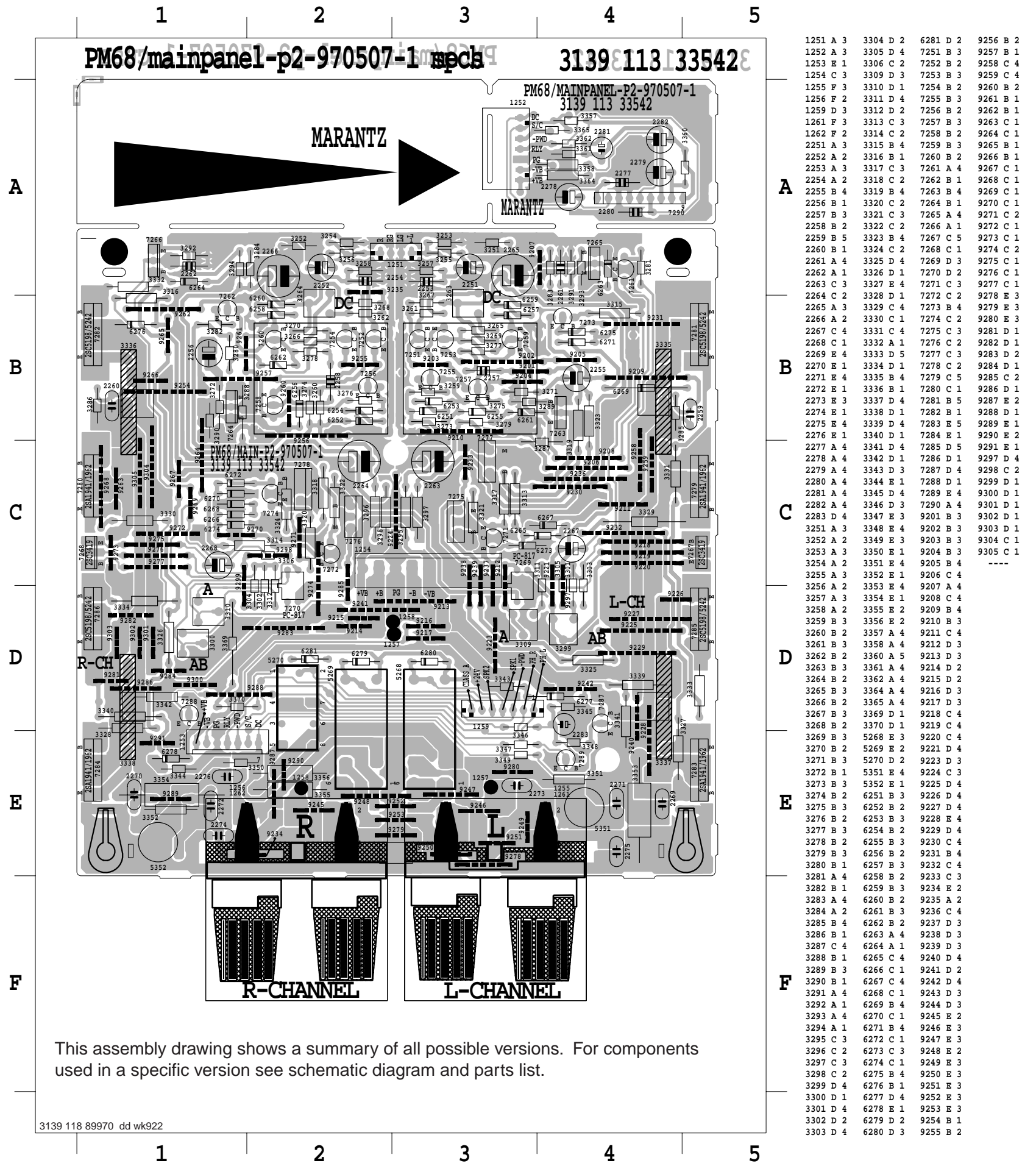

7. EXPLODED VIEW AND PARTS LIST
EXPLODED VIEW

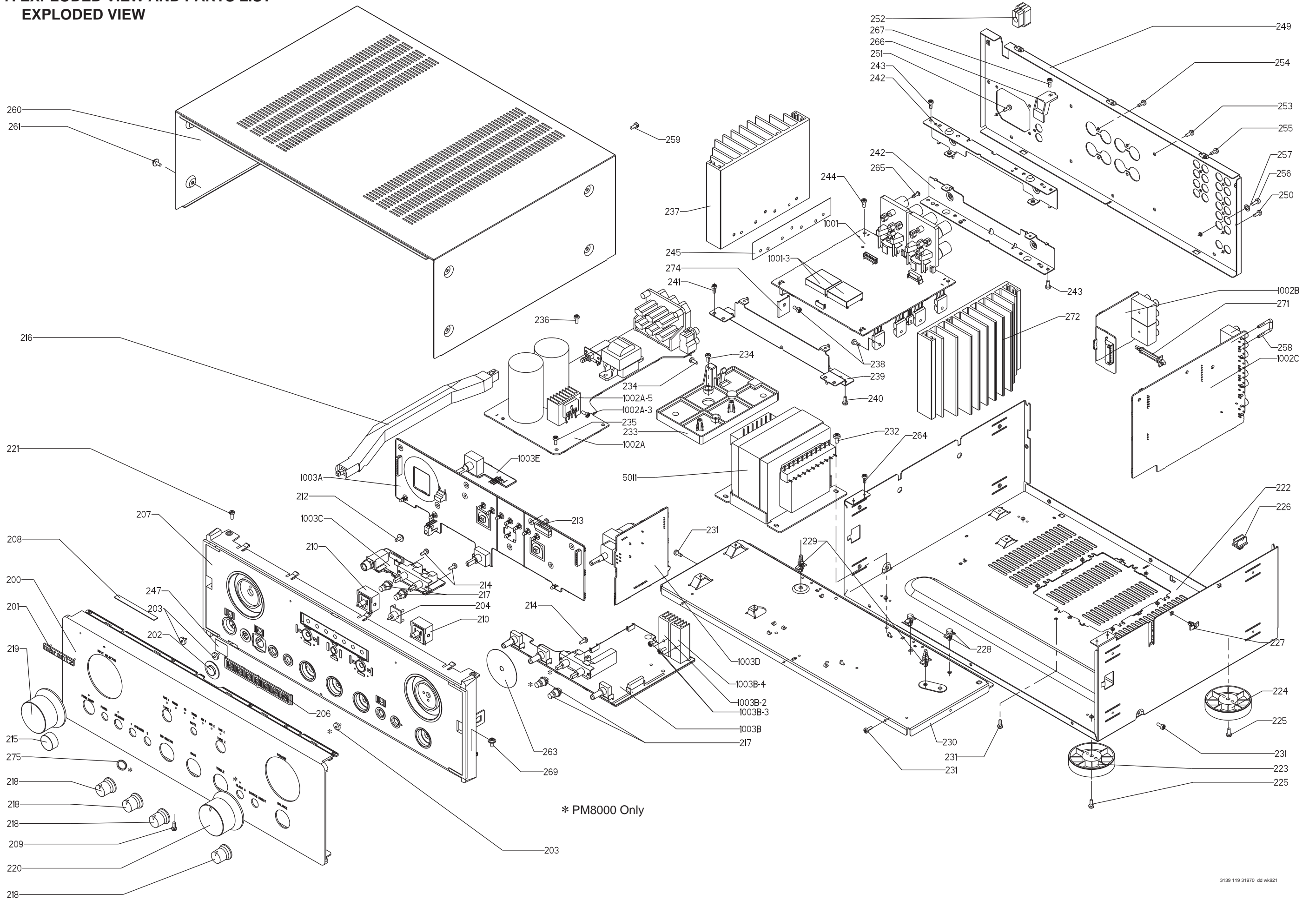

POS. NO	VERS. COLOR	PART NO. (PCS)	DESCRIPTION
200	PM7000 BLK	3139 117 88070	FRONT PANEL BLACK
200	PM8000 BLK	3139 117 88080	FRONT PANEL BLACK
200	PM7000 GLD	3139 117 88050	FRONT PANEL GOLD
200	PM8000 GLD	3139 117 88060	FRONT PANEL GOLD
201		4822 454 11825	PLATE, INDICATION
202	BLK	3139 114 66790	WINDOW IR BLACK
202	GLD	3139 114 66800	WINDOW IR GOLD
203		3139 114 66920	LIGHT GUIDE POWER/CLASS
204		3139 114 66900	LIGHT GUIDE MUTE
206		3139 114 66910	LIGHT GUIDE SOURCE
207	BLK	3139 114 66940	CABINET, FRONT BLACK
207	GLD	3139 117 88580	CABINET, FRONT GOLD
210	BLK	3139 114 66930	BUTTON TAPE BLACK
210	GLD	3139 117 88610	BUTTON TAPE GOLD
215	BLK	4822 410 12499	PUSH BUTTON, POWER
215	GLD	4822 410 12552	PUSH BUTTON, POWER
216		3139 114 66970	LINK, POWER
217	BLK	3139 114 66770	BUTTON, PUSH BLACK
217	GLD	3139 117 88600	BUTTON, PUSH GOLD
218	BLK	3139 114 66750	KNOB, ROTARY BLACK
218	GLD	3139 117 88590	KNOB, ROTARY GOLD
219	BLK	3139 117 88040	KNOB, SELECTOR BLACK
219	GLD	3139 117 88110	KNOB, SELECTOR GOLD
220	BLK	3139 117 88030	KNOB, VOL BLACK
220	GLD	3139 117 88090	KNOB, VOL GOLD
223		4822 462 42129	FOOT FRONT
224		4822 462 42129	FOOT REAR
252		4822 532 60948	BUSH, PLASTIC
256		4822 502 13921	SCREW, STEEL
271		4822 404 10933	PLASTIC SUPPORT(LCBS-22)
▲ 385	N	4822 321 11139	MAINS CORD
▲ 385	U	4822 321 11464	MAINS CORD
▲ 385	F	4822 321 11349	MAINS CORD
1605		4822 323 10406	FLEX CABLE 15P
▲ 5011	PM7000 N	4822 146 10823	MAINS TRANSFORMER
▲ 5011	PM8000 N	4822 146 10844	MAINS TRANSFORMER
▲ 5011	PM7000 U	4822 146 10854	MAINS TRANSFORMER
▲ 5011	PM8000 F	4822 146 10853	MAINS TRANSFORMER
			PACKING
384		3139 228 82240	REMOTE CONTROL RC0465/02
387	N	3139 116 18910	USER GUIDE
387	U	3139 116 18920	USER GUIDE
387	F	3139 116 18930	USER GUIDE

8. IDLING CURRENT AND DC OFFSET VOLTAGE ALIGNMENT

8.1 Quiescent Current Adjustment for Class AB

-Set to CD mode with no input, minimum volume position & mains supply at 230 V \pm 5 %.

-Power up the unit, adjust **SLOWLY** 3299 (L) & 3300 (R) until voltage across L-Channel -----3335 (T007 / T006) & 3337 (T009 / T010), R-Channel ----- 3336 (T013 / T014) & 3338 (T015 / T016) is as per the table below.

Time	Voltege
after 30 sec to 1 min*	0.3 mV to < 0.4 mV

- After 30 min, the voltage should settle down to 18 mV \pm 3 mV.

* Start from cold condition.

8.2 Quiescent Current Adjustment for Class A.

- Next, switch to Class A operation. Adjust **SLOWLY** 3309 (L) & 3310 (R) until voltage across L-Channel ----- 3335 (T007 / T006) & 3337 (T009 / T010) , R-Channel ----- 3336 (T013 / T014) & 3338 (T015 / T016) is as per the table below.

Time	Voltage
after 0 sec to 30 sec**	65 mV to <70 mV

- After 30 min, the voltage should settle down to 90 mV \pm 5 mV.

** Continue immediately after 8.1

REMARKS:

- Please take note that for both Class AB & A alignment, at all time during adjustment, refer to the higher reading of each channel.

Quiescent Current
Measurement point

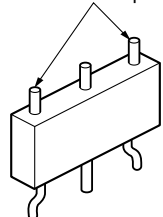

POS.No.
3335
3337
3336
3338

8.3 DC Offset.

- Adjust 3263 and 3264 until DC offset voltage is less than \pm 10 mV at Speaker output terminal.

8.アイドリング電流およびDCオフセット電圧調整

8.1 アイドリング電流調整 (Class AB)

- 1) 本体の電源スイッチを入れる前に、ボリュームを最小に、バランス及びトーンコントロールをセンターに合わせます。
- 2) CDモードにし、電源電圧を100Vにします。
- 3) セメント抵抗、3335 (T007 / T006) 、3337 (T009 / T010) のLチャンネルと3336 (T013 / T014) 、3338 (T015 / T016) のRチャンネル各々の電圧が下記の値になるまで、半固定抵抗3299 (L) と3300 (R) をゆっくり調整します。

時間	電圧
30秒ー1分*	0.3mV以上0.4mV以下

30分後、電圧は18mV \pm 3mVに安定します。

*冷却状態からスタートします。

8.2アイドリング電流調整 (Class A)

- 1) A クラス動作に切り換えます。
- 2) セメント抵抗3335 (T007 / T006)、3337 (T009 / T010) のLチャンネルと3336 (T013 / T014)、3338(T015 / T016)のRチャンネル各々の電圧が下記の値になるまで、半固定抵抗3309 (L) と3310 (R) ゆっくり調整します。

時間	電圧
0秒ー30秒 **	65mV以上70mV以下

30分後、電圧は90mV \pm 5mVに安定します。

**切換え後、すぐに行ってください。

注意：Aクラス動作及びABクラス動作のアイドル電流調整において、同チャンネル内の2ヶ所の測定点で指示値に差異があった場合は、高い方の電圧値が調整範囲内となるようにします。

アイドル電流
測定点

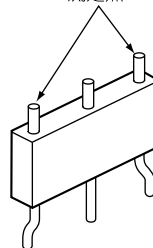

POS.No.
3335
3337
3336
3338

8.3 DCオフセット電圧調整

DCオフセット電圧が、スピーカー出力端子で10mV以下になるまで半固定抵抗3263と3264を調整します。

9. ELECTRICAL PARTS LIST

ASSIGNMENT OF COMMON PARTS CODES.

RESISTORS

R* ** : 1) GD05 x x x 140, Carbon film fixed resistor, ±5% 1/4W
 R* ** : 2) GD05 x x x 160, Carbon film fixed resistor, ±5% 1/6W
 ① Resistance value

Examples ;

① Resistance value
 0.1 Ω 001 10 Ω 100 1k Ω... 102 100k Ω 104
 0.5 Ω 005 18 Ω 180 2.7k Ω... 272 680k Ω 684
 1 Ω 010 100 Ω 101 10k Ω... 103 1M Ω 105
 6.8 Ω 068 390 Ω 391 22k Ω... 223 4.7M Ω 475

Note : Please distinguish 1/4W from 1/6W by the shape of parts used actually.

CAPACITORS

C* ** : CERAMIC CAP.

3) DD1 x x x x 370, Ceramic capacitor
 Disc type
 Temp.coef. P350~N1000, 50V
 ③ Capacity value
 ② Tolerance

Examples

② ATolerance (Capacity deviation)
 ± 0.25 pF 0
 ± 0.5 pF 1
 ± 5 % 5

* Tolerance of COMMON PARTS handled here are as follows :

0.5 pF - 5 p ± 0,25 pF
 6 pF - 10 pF ± 0.5 pF
 12 F - 560 pF... ± 5 %

③ Capacity value

0.5 pF 005 3 pF 030 100 pF 101
 1 pF 010 10 pF 100 220 pF 221
 1.5 p 015 47 pF 470 560 pF 561

C* ** : CERAMIC CAP.

4) DK16 x x x 300, High dielectric constant ceramic capacitor
 Disc type
 Temp.chara. 2B4, 50V
 ④ Capacity value

Examples

④ Capacity value
 100 pF 101 1000 pF 102 10000 pF 103
 470 pF 471 2200 pF 222

C* ** 5) ELECTROLY CAP. (), 6) FILM CAP ()

5) EA x x x x x 10, Electrolytic capacitor
 One-way lead type Tolerance ±20%
 ⑤ Capacity value
 ⑥ Working voltage

Examples

⑤ Capacity value
 0.1 μ F 04 4.7 μ F 475 100 μ F 107
 0.33 μ F 334 10 μ F 106 330 μ F 337
 1 μ F 105 22 μ F 226 1100 μ F 118
 2200 μ F 228

⑥ Working voltage

6.3 V. . .006 25 V. . .025
 10 V. . .010 35 V. . .035
 16 V. . .016 50 V. . .050
 6) DF15 x x x 350 → Plastic film capacitor
 DF15 x x x 310 → One-way type, Mylar ±5% 50V
 DF16 x x x 310 → Plastic film capacitor
 One-way type, Mylar ±10% 50V

⑦ Capacity value

Examples

⑦ Capacity value
 0.001 μ F (1000pF) 102 0.1 μ F 104
 0.0018 μ F 182 0.56 μ F 564
 0.01 μ F 103 1 μ F 105
 0.015 μ F 151

NOTE : 1) The above CODES(R* **, R* **C* **C* ** and C* **) are omitted on the schematic diagram in some case.

- 2) On the occasion, be confirmed the common parts on the parts list.
- 3) Refer to "Common Parts List" for the other common parts(RI05, DD4, DK4).

NOTE ON SAFETY FOR FUSIBLE RESISTOR :

The suppliers and their type numbers of fusible resistors are as follows ;

1 . KOA Corporation
 Part No.(MJI) Type No.(KOA) Description
 NH05 x x x 140 → RF25S x x x x Ω J (±5% 1/4W)
 NH05 x x x 120 → RF50S x x x x Ω J (±5% 1/2W)
 NH85 x x x 110 → RF73B2A x x x x Ω J (±5% 1/10W)
 NH95 x x x 140 → RF73B2E x x x x Ω J (±5% 1/4W)
 *Resistance value Resistance value(0.1 Ω- 10k Ω)

2. Matsushita Electronic Components Co., Ltd

Part No.(MJI) Type No.(MEC) Description
 NF05 x x x 140 → ERD-2FCJ x x x (±5% 1/4W)
 RF05 x x x 140 → ERD-2FCG x x x (±2% 1/4W)
 NF02 x x x 140 → ERD-2FCG x x x
 RF02 x x x 140 → ERD-2FCG x x x
 *Resistance value



Examples :

* Resistance value
 0.1 Ω 001 10 Ω 100 1k Ω.. 102 100k Ω 104
 0.5 Ω 005 18 Ω 180 2.7k Ω.. 272 680k Ω 684
 1 Ω 010 100 Ω 101 10k Ω.. 103 1M Ω 105
 6.8 Ω 068 390 Ω 391 22k Ω.. 23 4.7M Ω 475

ABBREVIATION AND MARKS

ANT. : ANTENNA	BATT. : BATTERY
CAP. : CAPACITOR	CER. : CERAMIC
CONN. : CONNECTING	DIG. : DIGITAL
HP : HEADPHONE	MIC. : MICROPHONE
μ -PRO : MICROPROCESSOR	REC. : RECORDING
RES. : RESISTOR	SPK : SPEAKER
SW : SWITCH	TRANSF. : TRANSFORMER
TRIM. : TRIMMING	TRS. : TRANSISTOR
VAR. : VARIABLE	X ' TAL : CRYSTAL

NOTE ON SAFETY:

Symbol  Fire or electrical shock hazard. Only original parts should be used to replaced any part marked with symbol  . Any other component substitution (other than original type), may increase risk of fire or electrical shock hazard.

安全上の注意 :

 がついている部品は、安全上重要な部品です。必ず指定されている部品番号の部品を使用して下さい。

POS. NO	VERS. COLOR	PART NO. (PCS)	DESCRIPTION	POS. NO	VERS. COLOR	PART NO. (PCS)	DESCRIPTION
			FUNCTION CIRCUIT BOARD CAPACITORS				SEMICONDUCTORS
2551		4822 126 12147	CER. 22NF 10% 25V	6605		4822 130 30621	DIODE 1N4148
2552		4822 126 12147	CER. 22NF 10% 25V	6608		4822 130 30621	DIODE 1N4148
2553	N	4822 122 33519	CER. 470pF 10% 50V	7555		4822 209 31153	IC NJM2114D
2554	N	4822 122 33519	CER. 470pF 10% 50V	7551			
2555	N	4822 126 14316	CER. 680pF 10% 50V	}		4822 130 42839	FET 2SK369BL
2555	U, F	4822 122 33849	CER. 150pF 10% 50V	7554			
2556	N	4822 126 14316	CER. 680pF 10% 50V	7601		4822 130 44568	TRS. BC557B
2556	U, F	4822 122 33849	CER. 150pF 10% 50V	7602		4822 130 40959	TRS. BC547B
2559		4822 124 12023	ELECT 47μF 20% 25V				
2560		4822 124 12023	ELECT 47μF 20% 25V	1551		4822 265 10311	CONNECTOR, 2P
2561		4822 121 70654	FILM 2N2 10% 50V	1601		4822 265 10311	CONNECTOR, 2P
2562		4822 121 70654	FILM 2N2 10% 50V	1602	PM7000	4822 267 20453	CONNECTOR, 6P
2563		4822 121 51399	FILM 47NF 10% 50V	1602	PM8000	4822 265 11061	CONNECTOR, 6P
2564		4822 121 51399	FILM 47NF 10% 50V	1603	PM7000	4822 267 31452	CONNECTOR, CABLE/WIRE
2565		4822 121 10685	FILM 1.8NF 10% 50V	1603	PM8000	4822 265 30996	CONNECTOR, CABLE/WIRE
2566		4822 121 10685	FILM 1.8NF 10% 50V	1604		4822 267 50915	CONNECTOR, 15P
2567		4822 121 41935	FILM 12NF 5% 250V	5551		4822 280 20501	RELAY MR62-24SR
2568		4822 121 41935	FILM 12NF 5% 250V	5601			
2569		4822 124 12024	ELECT 10μF 20% 16V	}		4822 280 20501	RELAY MR62-24SR
2570		4822 124 12024	ELECT 10μF 20% 16V	5612			
2571		4822 121 10696	FILM 4.7NF 2% 50V				
2572		4822 121 10696	FILM 4.7NF 2% 50V				
2573		4822 124 12022	ELECT 220μF 20% 25V				
2574		4822 124 12022	ELECT 220μF 20% 25V	2631			
2575		4822 124 40248	ELECT 10μF 20% 63V	}		4822 126 12147	CER. 22NF 10% 25V
2601				2638			
}		4822 126 12147	CER. 22NF 10% 25V	2639			
2612				}	N	4822 122 33849	CER. 150pF 10% 50V
2613				2646			
}	N	4822 122 33849	CER. 150pF 10% 50V				
2624				3621			
2647				}		4822 116 83866	1M 5% 1/6W
}		4822 124 40248	ELECT 10μF 20% 63V	3628			
2656				3629			
2659		4822 124 11566	ELECT 47μF 20% 50V	}		4822 116 83883	470R 5% 0.5W
				3632			
			RESISTORS				
3551		4822 116 83872	220R 5% 0.5W				
3552		4822 116 83872	220R 5% 0.5W	1611	PM7000	4822 267 31452	CONNECTOR, CABLE/WIRE
3553		4822 116 83884	47K 5% 0.5W	1611	PM8000	4822 265 30996	CONNECTOR, CABLE/WIRE
3554		4822 116 83884	47K 5% 0.5W	1612	PM7000	4822 267 31452	CONNECTOR, CABLE/WIRE
3555				1612	PM8000	4822 265 30996	CONNECTOR, CABLE/WIRE
}		4822 116 52283	4K7 5% 0.5W				
3560							
3561		4822 116 52206	120E 5% 0.5W				
3562		4822 116 52206	120E 5% 0.5W	2653		4822 122 33195	CER. 100pF 10% 50V
3563		4822 116 52175	100E 5% 0.5W	2654		4822 122 33195	CER. 100pF 10% 50V
3564		4822 116 52175	100E 5% 0.5W	2657		4822 122 33524	CER. 22pF 5% 50V
3565		4822 116 52234	100K 5% 0.5W	2658		4822 122 33524	CER. 22pF 5% 50V
3566		4822 116 52234	100K 5% 0.5W	2659		4822 126 12339	CER. 2.2NF 10%
3567		4822 116 52289	5K6 5% 0.5W	2660		4822 126 12339	CER. 2.2NF 10%
3568		4822 116 52289	5K6 5% 0.5W	2661		4822 124 12026	ELECT 22μF 20% 25V
3569		4822 116 52175	100E 5% 0.5W	2662		4822 124 12026	ELECT 22μF 20% 25V
3570		4822 116 52175	100E 5% 0.5W	2663		4822 121 10686	FILM 4.7NF 10% 50V
3571		4822 116 52234	100K 5% 0.5W	2664		4822 121 10686	FILM 4.7NF 10% 50V
3572		4822 116 52234	100K 5% 0.5W	2665		4822 124 12434	ELECT 220μF 20% 16V
3573		4822 116 83872	220R 5% 0.5W	2666		4822 124 12434	ELECT 220μF 20% 16V
3574		4822 116 83872	220R 5% 0.5W	2667		4822 124 40769	ELECT 4.7μF 20% 100V
3575		4822 052 10479	47R 5% 0.33W	2668		4822 124 40769	ELECT 4.7μF 20% 100V
3576		4822 052 10479	47R 5% 0.33W	2669		4822 124 12027	ELECT 2.2μF 20% 50V
3601				2670		4822 124 12027	ELECT 2.2μF 20% 50V
}		4822 116 83866	1M 5% 0.5W	2671		4822 122 30043	CER. 10NF 80% 63V
3618							
3633		4822 050 21003	10K 1% 0.6W				
3634		4822 050 21003	10K 1% 0.6W				
3635		4822 050 21003	10K 1% 0.6W				
3637		4822 050 21003	10K 1% 0.6W				

POS. NO	VERS. COLOR	PART NO. (PCS)	DESCRIPTION	POS. NO	VERS. COLOR	PART NO. (PCS)	DESCRIPTION
			RESISTORS				
3651	PM7000	4822 116 83874	220K 5% 0.5W	3416			
3651	PM8000	4822 116 52244	15K 5% 0.5W	3422		4822 116 83881	390R 5% 0.5W
3652	PM7000	4822 116 83874	220K 5% 0.5W	3423			
3652	PM8000	4822 116 52244	15K 5% 0.5W	3426		4822 116 52234	100K 5% 0.5W
3653		4822 050 11002	1K 1% 0.4W	3427			
3654		4822 050 11002	1K 1% 0.4W	3436		4822 050 21003	10K 1% 0.6W
3655	PM7000	4822 116 52206	120E 5% 0.5W	3437		4822 116 52234	100K 5% 0.5W
3655	PM8000	4822 116 83876	270R 5% 0.5W	3438		4822 116 52234	100K 5% 0.5W
3656	PM7000	4822 116 52206	120E 5% 0.5W	3439		4822 116 52234	100K 5% 0.5W
3656	PM8000	4822 116 83876	270R 5% 0.5W	3440		4822 116 83872	220R 5% 0.5W
3657				3441		4822 116 52234	100K 5% 0.5W
3662		4822 116 52283	4K7 5% 0.5W	3442		4822 050 23303	33K 1% 0.6W
3663		4822 116 83872	220R 5% 0.5W	3443		4822 116 52257	22K 5% 0.5W
3664		4822 116 83872	220R 5% 0.5W	3444		4822 116 52283	4K7 5% 0.5W
3665		4822 116 83866	1M 5% 0.5W	3445		4822 116 52256	2K2 5% 0.5W
3666		4822 116 83866	1M 5% 0.5W	3446		4822 116 52257	22K 5% 0.5W
3667	PM7000	4822 050 11002	1K 1% 0.4W	3447		4822 116 52175	100E 5% 0.5W
3667	PM8000	4822 116 52256	2K2 5% 0.5W	3448			
3668	PM7000	4822 050 11002	1K 1% 0.4W	3451		4822 050 21003	10K 1% 0.6W
3668	PM8000	4822 116 52256	2K2 5% 0.5W	3452		4822 052 10101	100R 5% 0.33W
3669		4822 116 52175	100E 5% 0.5W	3453			
3670		4822 116 52175	100E 5% 0.5W	3459		4822 050 21003	10K 1% 0.6W
3671		4822 116 52234	100K 5% 0.5W	3460		4822 116 52257	22K 5% 0.5W
3672		4822 116 52234	100K 5% 0.5W	3461		4822 050 21003	10K 1% 0.6W
3673		4822 116 83872	220R 5% 0.5W	3462		4822 116 83884	47K 5% 0.5W
3674		4822 116 83872	220R 5% 0.5W	3463		4822 050 21003	10K 1% 0.6W
▲ 3675		4822 052 10479	47R 5% 0.33W	3464		4822 050 21003	10K 1% 0.6W
▲ 3676		4822 052 10479	47R 5% 0.33W	3465		4822 116 52257	22K 5% 0.5W
3681	PM7000	4822 101 11789	VARIAB. 50K X2 20% 0.05W	3466		4822 116 52195	47E 5% 0.5W
3681	PM8000	4822 101 11803	VARIAB. RK16314MC(50KX2)	3467		4822 052 10101	100R 5% 0.33W
			SEMICONDUCTORS	3468			
7651				3488		4822 050 21003	10K 1% 0.6W
7654		4822 130 42839	FET 2SK369BL	3489		4822 116 83884	47K 5% 0.5W
7655		4822 209 31153	IC NJM2114D	3490		4822 050 21003	10K 1% 0.6W
			FRONT CIRCUIT BOARD	3491		4822 116 83884	47K 5% 0.5W
			CAPACITORS	3492		4822 050 21003	10K 1% 0.6W
2401		4822 121 51387	FILM 10NF 20% 16V	3493		4822 116 83884	47K 5% 0.5W
2403		4822 121 51387	FILM 10NF 20% 16V	3494		4822 050 21003	10K 1% 0.6W
2404		4822 124 81151	ELECT 22µF 50V	3495		4822 116 83872	220R 5% 0.5W
2405		4822 124 81151	ELECT 22µF 50V	3496		4822 116 52256	2K2 5% 0.5W
2406		4822 124 80818	ELECT 22M 5.5V	3541	PM8000	4822 053 10332	3K30 5% 1W
2407		4822 126 12882	CER. 100NF +80-20% 50V	3542		4822 050 21003	10K 1% 0.6W
2408		4822 124 81151	ELECT 22µF 50V	3543		4822 116 83881	390R 5% 0.5W
2409		4822 124 81151	ELECT 22µF 50V	3544		4822 050 21003	10K 1% 0.6W
2410		4822 121 51387	FILM 10NF 20% 16V	3545		4822 116 83881	390R 5% 0.5W
2411		4822 121 51387	FILM 10NF 20% 16V	3546		4822 050 21003	10K 1% 0.6W
2412		4822 124 81151	ELECT 22µF 50V	3547		4822 050 21003	10K 1% 0.6W
2413		4822 121 51387	FILM 10NF 20% 16V				
2414		4822 126 12882	CER. 100NF +80-20% 50V				
2415		4822 124 81151	ELECT 22µF 50V				
2416		4822 121 51387	FILM 10NF 20% 16V	6401			
2417		4822 121 51387	FILM 10NF 20% 16V	6404		4822 130 30621	DIODE 1N4148
2425				6405		4822 130 34174	DIODE BZX79-B4V7
2428		4822 126 12882	CER. 100NF +80-20% 50V	6406		4822 130 82978	LED LTL-16KPE-P
			RESISTORS	6413			
3401		4822 052 10101	100R 5% 0.33W	6414	PM8000	4822 130 82978	LED LTL-16KPE-P
3402		4822 116 52234	100K 5% 0.5W	6415		4822 130 82978	LED LTL-16KPE-P
3403				6416		4822 130 82978	LED LTL-16KPE-P
3408		4822 050 21003	10K 1% 0.6W	6417		4822 130 30621	DIODE 1N4148
				6418		4822 130 30621	DIODE 1N4148
				7401		4822 209 15719	IC TMP47C200BN
				7402		4822 209 30193	IC LB1641

POS. NO	VERS. COLOR	PART NO. (PCS)	DESCRIPTION	POS. NO	VERS. COLOR	PART NO. (PCS)	DESCRIPTION
7404		4822 130 40959	TRS. BC547B	2509		4822 122 33293	CER. 100pF 5% 50V
7405		4822 130 40959	TRS. BC547B	2510		4822 122 33293	CER. 100pF 5% 50V
7406		4822 130 40959	TRS. BC547B	2511		4822 124 40769	ELECT 4.7μF 20% 100V
7407		4822 130 44568	TRS. BC557B	2512		4822 124 40769	ELECT 4.7μF 20% 100V
7408		4822 130 40959	TRS. BC547B	2513		4822 121 51399	FILM 47NF 10% 50V
7409				2514		4822 121 51399	FILM 47NF 10% 50V
7412		4822 130 44568	TRS. BC557B	2515		4822 124 12022	ELECT 220μF 20% 25V
7413		4822 130 40959	TRS. BC547B	2516		4822 124 12022	ELECT 220μF 20% 25V
7414		4822 130 40959	TRS. BC547B	2517		4822 124 40763	ELECT 2.2μF 100 V
7415		4822 130 44568	TRS. BC557B	2518		4822 124 40763	ELECT 2.2μF 100 V
7416		4822 130 40959	TRS. BC547B	2519		4822 121 10686	FILM 4.7NF 10% 50V
7417		4822 130 44568	TRS. BC557B	2520		4822 121 10686	FILM 4.7NF 10% 50V
7418		4822 130 40959	TRS. BC547B	2535		4822 122 33195	CER. 100pF 10% 50V
7419		4822 130 44568	TRS. BC557B	2536		4822 122 33195	CER. 100pF 10% 50V
7420		4822 130 40959	TRS. BC547B				RESISTORS
7421		4822 130 44568	TRS. BC557B	▲ 3203		4822 052 10479	47R 5% 0.33W
7422		4822 130 40959	TRS. BC547B	3501			
7423		4822 130 44568	TRS. BC557B	}		4822 116 83866	1M 5% 0.5W
7424		4822 130 40959	TRS. BC547B	3504			
7425		4822 130 44568	TRS. BC557B	3505		4822 116 83874	220K 5% 0.5W
7426		4822 130 40959	TRS. BC547B	3506		4822 116 83874	220K 5% 0.5W
7427		4822 130 44568	TRS. BC557B	3507		4822 116 83872	220R 5% 0.5W
7428				3508		4822 116 83872	220R 5% 0.5W
7431		4822 130 40959	TRS. BC547B	3509		4822 116 52269	3K3 5% 0.5W
7432		4822 130 44568	TRS. BC557B	3510		4822 116 52269	3K3 5% 0.5W
7433		4822 130 44568	TRS. BC557B	3511		4822 101 11788	VARIAB. 10K X2 20% 0.05W
7434		4822 130 40959	TRS. BC547B	3512		4822 101 11788	VARIAB. 10K X2 20% 0.05W
			MISCELLANEOUS	▲ 3513		4822 052 10479	47R 5% 0.33W
1401		4822 276 13114	SWITCH, PUSH BUTTON	▲ 3514		4822 052 10479	47R 5% 0.33W
1402		4822 276 13114	SWITCH, PUSH BUTTON	3515		4822 116 52207	1K2 5% 0.5W
1403		4822 273 10336	SWITCH, ROTARY	3516		4822 116 52207	1K2 5% 0.5W
			SRBV14-F1620-11	3517		4822 116 52291	56K 5% 0.5W
1407		4822 267 51322	CONNECTOR, 15P	3518		4822 116 52291	56K 5% 0.5W
5400		4822 242 72527	FILTER, CERAMIC	3519		4822 116 52207	1K2 5% 0.5W
			CST4.00MGW-TF01	3520		4822 116 52207	1K2 5% 0.5W
5401		4822 157 50963	COIL 2.2μH	3521		4822 116 52291	56K 5% 0.5W
7403		4822 130 10165	REMOTE RECEIVER GP1U28XP	3522		4822 116 52291	56K 5% 0.5W
			ENCODER CIRCUIT BOARD	3523		4822 052 10479	47R 5% 0.33W
3497		4822 116 52175	RES. 100E 5% 0.5W	▲ 3524		4822 052 10479	47R 5% 0.33W
3498		4822 116 52175	RES. 100E 5% 0.5W	3525		4822 116 83872	220R 5% 0.5W
				3526		4822 116 83872	220R 5% 0.5W
1404		4822 273 10237	SWITCH, ROTARY	3527		4822 116 83874	220K 5% 0.5W
			SRRS1C(G79424930)	3528		4822 116 83874	220K 5% 0.5W
			TONE CIRCUIT BOARD	3529		4822 101 30828	VARIAB. 100K
			CAPACITORS	3537		4822 116 52269	3K3 5% 0.5W
2201		4822 122 30043	CER. 10NF 80% 63V	3538		4822 116 52269	3K3 5% 0.5W
2202		4822 122 30043	CER. 10NF 80% 63V	3539		4822 116 52234	100K 5% 0.5W
2203		4822 124 12025	ELECT 470μF 20% 35V	3540		4822 116 52234	100K 5% 0.5W
2204		4822 124 41329	ELECT 2200μF 20% 35V	▲ 6201		4822 130 31878	SEMICONDUCTORS
2205		4822 124 12022	ELECT 220μF 20% 25V	▲ 6202		4822 130 31878	DIODE 1N4003G
2206		4822 124 12022	ELECT 220μF 20% 25V	▲ 6203		4822 130 31878	DIODE 1N4003G
2207		4822 124 12025	ELECT 470μF 20% 35V	▲ 6204		4822 130 31878	DIODE 1N4003G
2208		4822 124 40257	ELECT 220μF 20% 63V	7201		5322 209 86361	IC MC7915CT
2209		4822 124 12025	ELECT 470μF 20% 35V	7202		5322 209 71759	IC MCT7815CT
2210		4822 124 12025	ELECT 470μF 20% 35V	7203		5322 130 44349	TRS. BC635
2211	N	4822 122 30103	CER. 22NF 80% 63V	7501		4822 209 73064	IC NJM2068DD
2501		4822 124 81151	ELECT 22μF 50V	7502		4822 209 73064	IC NJM2068DD
2502		4822 124 81151	ELECT 22μF 50V	7503		4822 209 73064	IC NJM2068DD
2503		4822 122 33849	CER. 150pF 10% 50V	▲ 1201		4822 071 55001	MISCELLANEOUS
2504		4822 122 33849	CER. 150pF 10% 50V	▲ 1202		4822 071 55001	FUSE 19372(500MA)
2505		4822 124 12022	ELECT 220μF 20% 25V	1500		2422 128 02902	FUSE 19372(500MA)
2506		4822 124 12022	ELECT 220μF 20% 25V				SWITCH, PUSH
2507		4822 121 41857	FILM 10NF 5% 250V				
2508		4822 121 41857	FILM 10NF 5% 250V				

POS. NO	VERS. COLOR	PART NO. (PCS)	DESCRIPTION	POS. NO	VERS. COLOR	PART NO. (PCS)	DESCRIPTION
			POWER CIRCUIT BOARD CAPACITORS				MAIN CIRCUIT BOARD CAPACITORS
▲ 2201		2020 558 90382	CER. CERSAF KC-F 250V S 10N PM20	2251		4822 124 12023	ELECT 47μF 20% 25V
▲ 2202		2020 558 90382	CER. CERSAF KC-F 250V S 10N PM20	2252		4822 124 12023	ELECT 47μF 20% 25V
2204	U, F	5322 121 42498	CER. 680NF 5% 63V	2253		4822 122 33197	CER. 1NF 10% 50V
2205		4822 124 12028	ELECT 12000μF 20% 63V	2254		4822 122 33197	CER. 1NF 10% 50V
2206		4822 124 12028	ELECT 12000μF 20% 63V	2255		4822 124 12022	ELECT 220μF 20% 25V
2207	PM8000	4822 124 42391	ELECT 470μF 20% 63V	2256		4822 124 12022	ELECT 220μF 20% 25V
2208	PM8000	4822 124 42391	ELECT 470μF 20% 63V	2257	PM7000	4822 122 33519	CER. 470pF 10% 50V
2209		4822 121 51319	FILM 1μF 1% 63V	2258	PM8000	4822 126 12339	CER. 2.2NF 10%
2210		4822 124 21913	ELECT 1μF 20% 63V	2259	PM7000	4822 126 14164	CER. 10pF 5% 50V
2211		4822 124 80141	CER. 10NF 10% 50V	2259	PM8000	4822 122 31822	CER. 4.7pF 10% 100V
2212		4822 124 80141	CER. 10NF 10% 50V	2260	PM7000	4822 126 14164	CER. 10pF 5% 50V
2214	U, F	5322 121 42498	CER. 680NF 5% 63V	2260	PM8000	4822 122 31822	CER. 4.7pF 10% 100V
2217	N	4822 121 51387	FILM 10NF 20% 16V	2261	PM7000	4822 122 33519	CER. 470pF 10% 50V
2302		4822 124 12022	ELECT 220μF 20% 25V	2261	PM8000	4822 122 33197	CER. 1NF 10% 50V
2304		4822 124 12056	ELECT 1000μF 20% 35V	2262	PM7000	4822 122 33519	CER. 470pF 10% 50V
2305		4822 124 40433	ELECT 47μF 20% 25V	2262	PM8000	4822 122 33197	CER. 1NF 10% 50V
2401		4822 126 12333	CER. 100NF 10% 25V	2263	PM7000	2020 012 93547	ELECT 100μF 20% 63V
			RESISTORS	2263	PM8000	4822 124 40257	ELECT 220μF 20% 63V
3204	U, F	4822 050 26808	6R8 1% 0.6W	2264	PM7000	2020 012 93547	ELECT 100μF 20% 63V
▲ 3207		4822 052 10108	1R 5% 0.33W	2264	PM8000	4822 124 40257	ELECT 220μF 20% 63V
▲ 3208		4822 052 10479	47R 5% 0.33W	2265	PM7000	2020 012 93547	ELECT 100μF 20% 63V
▲ 3209		4822 052 10479	47R 5% 0.33W	2265	PM8000	4822 124 40257	ELECT 220μF 20% 63V
3210		4822 116 52234	100K 5% 0.5W	2266	PM7000	2020 012 93547	ELECT 100μF 20% 63V
3211		4822 116 52234	100K 5% 0.5W	2266	PM8000	4822 124 40257	ELECT 220μF 20% 63V
3217	PM8000	4822 053 10229	22R 5% 1W	2267		4822 124 12022	ELECT 220μF 20% 25V
3218	PM8000	4822 053 10229	22R 5% 1W	2268		4822 124 12022	ELECT 220μF 20% 25V
			SEMICONDUCTORS	2269			
6202		4822 130 30621	DIODE 1N4148	}		5322 121 42386	FILM 100NF 0.05 63V
6204	PM8000	4822 130 30621	DIODE 1N4148	2272			
▲ 6205		4822 130 10944	DIODE BRIDGE GBU6D	2273			
6206				}	N	4822 124 80141	CER. 10NF 10% 50V
}	PM8000	4822 130 31878	DIODE 1N4003G	2276		4822 124 21913	ELECT 1μF 20% 63V
6209				2283			
▲ 6210		4822 130 31878	DIODE 1N4003G	3251		4822 116 52176	10E 5% 0.5W
}				3252		4822 116 52176	10E 5% 0.5W
▲ 6216		4822 130 30621	DIODE 1N4148	3253		4822 116 83874	220K 5% 0.5W
6302		4822 130 30621	DIODE 1N4148	3254		4822 116 83874	220K 5% 0.5W
▲ 7302		4822 209 80817	IC L7805CV	3255		4822 050 11002	1K00 1% 0.4W
			MISCELLANEOUS	3256		4822 050 11002	1K00 1% 0.4W
▲ 1201		2422 128 02898	SWITCH, PUSH	3257		4822 116 52264	27K 5% 0.5W
▲ 1205	N	4822 070 32502	FUSE 21802.5(2.5A)	3258		4822 116 52264	27K 5% 0.5W
▲ 1206	N	4822 265 11009	MAINS OUTLET	3259		4822 116 52213	180E 5% 0.5W
▲ 1206	U, F	4822 265 11081	MAINS OUTLET	3260		4822 116 52213	180E 5% 0.5W
▲ 1209	N	4822 070 33152	FUSE 2183.15(3.15A)	3261		4822 116 83872	220R 5% 0.5W
▲ 1209	U, F	4822 070 36302	FUSE 21806.3(6.3A)	3262		4822 116 83872	220R 5% 0.5W
▲ 1213	PM8000	4822 071 54002	FUSE 19372(4A)	3263		4822 100 11213	VARIAB. 22K 30% LIN 0.1W
▲ 1214	PM8000	4822 071 54002	FUSE 19372(4A)	3264		4822 100 11213	VARIAB. 22K 30% LIN 0.1W
▲ 1215		4822 071 55001	FUSE 19372(500MA)	3265			
▲ 1216	PM8000	4822 071 55001	FUSE 19372(500MA)	}		4822 116 83872	220R 5% 0.5W
1401		4822 267 41009	CONNECTOR, CABLE/WIRE	3270			
▲ 5202		4822 280 10337	RELAY VS-12MB-NR (1P-12V)	3271		4822 116 52243	1K5 5% 0.5W
▲ 5204	PM8000	4822 280 10344	RELAY LY2-0-DC24 B	3272		4822 116 52243	1K5 5% 0.5W
▲ 5205	N	4822 146 10828	TRANSFORMER	3273		4822 050 11002	1K00 1% 0.4W
▲ 5205	U, F	4822 146 10861	TRANSFORMER	3274		4822 050 11002	1K00 1% 0.4W
				3275		4822 116 83884	47K 5% 0.5W
				3276		4822 116 83884	47K 5% 0.5W
				3277	PM7000	4822 116 83872	220R 5% 0.5W
				3277	PM8000	4822 116 52228	680E 5% 0.5W
				3278	PM7000	4822 116 83872	220R 5% 0.5W
				3278	PM8000	4822 116 52228	680E 5% 0.5W
				3279			
				}		4822 050 11002	1K 1% 0.4W
				3284			

POS. NO	VERS. COLOR	PART NO. (PCS)	DESCRIPTION	POS. NO	VERS. COLOR	PART NO. (PCS)	DESCRIPTION
3285		4822 116 52264	27K 5% 0.5W				SEMICONDUCTORS
3286		4822 116 52264	27K 5% 0.5W	6251			
3287		4822 116 83868	150R 5% 0.5W	}		4822 130 30621	DIODE 1N4148
3288		4822 116 83868	150R 5% 0.5W	6266			
3289	PM7000	4822 116 83874	220K 5% 0.5W	6267			
3289	PM8000	4822 116 83884	47K 5% 0.5W	}		5322 130 34834	DIODE BZX79-C3V6
3290	PM7000	4822 116 83874	220K 5% 0.5W	6270			
3290	PM8000	4822 116 83884	47K 5% 0.5W	6271		4822 130 30621	DIODE 1N4148
3291	PM7000	4822 116 83874	220K 5% 0.5W	6272		4822 130 30621	DIODE 1N4148
3291	PM8000	4822 116 83884	47K 5% 0.5W	6273			
3292	PM7000	4822 116 83874	220K 5% 0.5W	}		4822 130 30842	DIODE BAV21
3292	PM8000	4822 116 83884	47K 5% 0.5W	6278			
3293		4822 116 83868	150R 5% 0.5W	6279		4822 130 30621	DIODE 1N4148
3294		4822 116 83868	150R 5% 0.5W	6280		4822 130 30621	DIODE 1N4148
3295				6281		4822 130 30621	DIODE 1N4148
}		4822 052 10109	10E 5% 0.33W	7251			
3298				}		4822 130 43233	TRS. 2SC2240GR
3299		4822 101 11787	VARIAB. 100R 30% 0.1W	7256			
3300		4822 101 11787	VARIAB. 100R 30% 0.1W	7257			
3301		4822 116 83876	270R 5% 0.5W	}		4822 130 42949	TRS. 2SA970GR
3302		4822 116 83876	270R 5% 0.5W	7260			
3303		4822 116 52207	1K2 5% 0.5W	7261		4822 130 43233	TRS. 2SC2240GR
3304		4822 116 52207	1K2 5% 0.5W	7262		4822 130 43233	TRS. 2SC2240GR
3305		4822 116 80176	1E 5% 0.5W	7263		4822 130 61009	TRS. 2SC3423(O)
3306		4822 116 80176	1E 5% 0.5W	7264		4822 130 61009	TRS. 2SC3423(O)
3309	PM8000	4822 100 20166	VARIAB. 10K 30% LIN 0.1W	7265		5322 130 61728	TRS. 2SA1360-Y
3310	PM8000	4822 100 20166	VARIAB. 10K 30% LIN 0.1W	7266		5322 130 61728	TRS. 2SA1360-Y
3311		4822 050 11002	1K 1% 0.4W	▲7267		4822 130 60117	TRS. 2SC3419
3312		4822 050 11002	1K 1% 0.4W	▲7268		4822 130 60117	TRS. 2SC3419
3313				7269	PM8000	4822 130 90347	COUPLER /PHOTO PC817
}		4822 052 10101	100R 5% 0.33W	7270	PM8000	4822 130 90347	COUPLER /PHOTO PC817
3316				7271		4822 130 41646	TRS. BF423
3317				7272		4822 130 41646	TRS. BF423
}		4822 052 10681	680R 5% 0.33W	7273		4822 130 41782	TRS. BF422
3320				7274		4822 130 41782	TRS. BF422
3321				▲7275		4822 130 63634	TRS. 2SA1837Y
}		4822 052 10479	47R 5% 0.33W	▲7276		4822 130 63634	TRS. 2SA1837Y
3324				▲7277		4822 130 10941	TRS. 2SC4793
▲3325		4822 052 10151	150R 5% 0.33W	▲7278		4822 130 10941	TRS. 2SC4793
▲3326		4822 052 10151	150R 5% 0.33W	▲7279	PM7000	4822 130 10942	TRS. 2SA1941
▲3327				▲7279	PM8000	4822 130 37279	TRS. 2SA1962
}		4822 052 10109	10R 5% 0.33W	▲7280	PM7000	4822 130 10942	TRS. 2SA1941
▲3334				▲7280	PM8000	4822 130 10983	TRS. 2SA1962
▲3335				▲7281	PM7000	4822 130 10943	TRS. 2SC5198
}		4822 116 82049	2 X R18 3W	▲7281	PM8000	4822 130 10984	TRS. 2SC5242
▲3338				▲7282	PM7000	4822 130 10943	TRS. 2SC5198
3339				▲7282	PM8000	4822 130 10984	TRS. 2SC5242
}		4822 050 21002	1K 1% 0.6W	▲7283	PM7000	4822 130 10942	TRS. 2SA1941
3342				▲7283	PM8000	4822 130 10983	TRS. 2SA1962
3343		4822 116 52257	22K 5% 0.5W	▲7284	PM7000	4822 130 10942	TRS. 2SA1941
3344		4822 116 52257	22K 5% 0.5W	▲7284	PM8000	4822 130 10983	TRS. 2SA1962
3345		4822 116 52289	5K6 5% 0.5W	▲7285	PM7000	4822 130 10943	TRS. 2SC5198
3346		4822 116 52257	22K 5% 0.5W	▲7285	PM8000	4822 130 10984	TRS. 2SC5242
3347	PM7000	4822 116 52297	68K 5% 0.5W	▲7286	PM7000	4822 130 10943	TRS. 2SC5198
3347	PM8000	4822 116 83882	39K 5% 0.5W	▲7286	PM8000	4822 130 10984	TRS. 2SC5242
3348		4822 116 52257	22K 5% 0.5W	7287		4822 130 43233	TRS. 2SC2240GR
3349		4822 116 52297	68K 5% 0.5W	7288		4822 130 43233	TRS. 2SC2240GR
3350		4822 116 52297	68K 5% 0.5W	7289		4822 130 42949	TRS. 2SA970GR
3351		4822 052 10221	220R 5% 0.33W				
3352		4822 052 10221	220R 5% 0.33W				
3353		4822 053 12109	10R 5% 3W	1255		4822 265 11068	MISCELLANEOUS CONNECTOR,LOUDSPEAKER SOCKET LEFT
3354		4822 053 12109	10R 5% 3W				
3355		4822 053 11331	330R 5% 2W	1256		4822 265 11069	CONNECTOR,LOUDSPEAKER SOCKET RIGHT
3356		4822 053 11331	330R 5% 2W				
3369	PM8000	4822 050 11002	1K 1% 0.4W	5268		4822 280 70354	RELAY VB-24MBU-510
3370	PM8000	4822 050 11002	1K 1% 0.4W	5269		4822 280 70354	RELAY VB-24MBU-510
				5270		4822 280 20501	RELAY MR62-24SR
				5351		4822 157 70599	COIL
				5352		4822 157 70599	COIL

POS. NO	VERS. COLOR	PART NO. (PCS)	DESCRIPTION	POS. NO	VERS. COLOR	PART NO. (PCS)	DESCRIPTION
			SPK PROTECT CIRCUIT BOARD CAPACITORS				
2277		4822 121 51387	FILM 10NF 20% 16V				
2278		4822 124 40433	ELECT 47 μ F 20% 25V				
2279		4822 124 40433	ELECT 47 μ F 20% 25V				
2281		4822 124 21913	ELECT 1 μ F 20% 63V				
2282		4822 124 40433	ELECT 47 μ F 20% 25V				
			RESISTORS				
3357		4822 116 83884	47K 5% 0.5W				
3358		4822 053 10103	10K 5% 1W				
3360		4822 116 83874	220K 5% 0.5W				
3361		4822 050 23303	33K 1% 0.6W				
3362		4822 116 52291	56K 5% 0.5W				
3364		4822 053 10223	22K 5% 1W				
3365		4822 116 52234	100K 5% 0.5W				
			SEMICONDUCTOR				
7290		4822 209 83312	IC TA7317P				
			SPK SW CIRCUIT BOARD CAPACITORS				
2533		4822 122 30043	CER. 10NF 80% 63V				
2534		4822 122 30043	CER. 10NF 80% 63V				
			RESISTORS				
3530		4822 116 52256	2K2 5% 0.5W				
3531		4822 116 52256	2K2 5% 0.5W				
3532		4822 116 52257	22K 5% 0.5W				
3533		4822 116 52176	10E 5% 0.5W				
3534		4822 116 52176	10E 5% 0.5W				
3535		4822 116 52234	100K 5% 0.5W				
			SEMICONDUCTORS				
6529		4822 130 30621	DIODE 1N4148				
7529		4822 130 44283	TRS. BC636				
7530		4822 130 44568	TRS. BC557B				
			MISCELLANEOUS				
1507		2422 128 02897	SWITCH UNIT				
1510		4822 267 31453	CONNECTOR, HLJ1540				