

Service Manual

74PM-82/00B/01B/02B/05B/07B
/01G/02G

Integrated stereo amplifier

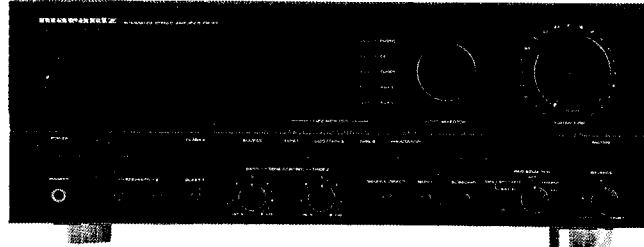

TABLE OF CONTENTS

SECTION	PAGE
1. BLOCK DIAGRAM	2
2. SCHEMATIC DIAGRAM AND PARTS LOCATION (Pattern Side)	4
3. EXPLODED VIEW AND PARTS LIST	17
4. TEST EQUIPMENT REQUIRED FOR SERVICING	19
5. IDLING CURRENT ADJUSTMENT	19
6. VOLTAGE CONVERSION	19
7. HOW TO CHANGE THE SUPPLY VOLTAGE	20
8. MICROPROCESSOR	20
9. ELECTRICAL PARTS LIST	21

marantz®

model PM-82

First issue : 1992

4822 725 50972

A.O

PCS 67 342

MARANTZ DESIGN AND SERVICE

Using superior design and selected high grade components, MARANTZ company has created the ultimate in stereo sound.

Only **original MARANTZ parts** can insure that your MARANTZ product will continue to perform to the specifications for which it is famous.

Parts for your MARANTZ equipment are generally available to our National Marantz Subsidiary or Agent.

ORDERING PARTS:

Parts can be ordered either by mail or by telex. In both cases, correct part number has to be specified.

The following information must be supplied to eliminate delays in processing your order:

1. Complete address
2. Complete part numbers and quantities required
3. Description of parts
4. Model number for which part is required
5. Way of shipment
6. Signature: any order form or telex must be signed otherwise such part order will be considered as null and void.

MARANTZ INTERNATIONAL
Vestdijk 9
5600 MD Eindhoven
The Netherlands
Phone: +31/40.758290
Telefax: +31/40.75.82.99
Telex: 35000 PHTC NL routing IND NLMTFAT

PARTS ORDERING

Parts may be ordered at the following addresses:

AUSTRIA
HORNYPHON
Vertriebsgesellschaft GmbH
Wienerbergstrasse 1
A 1101 Wien
Austria
Telex: 132.332

FINLAND
MARANTZ
DIVISION OF OY PHILIPS Ab
Kaivokatu 8
00100 Helsinki
Finland
Telex: 124811

GREAT BRITAIN
MARANTZ AUDIO U.K. Ltd
Unit 15/16
Saxon Way Industrial Estate
Moor Lane
Harmondsworth UB7 0LW
Great Britain
Telex: 935196

SAUDI ARABIA
AL ALAMIAH ELECTRONICS
P.O.Box 5954
University Street
Riyadh 11432
Saudi Arabia
Telex: 401530

SWITZERLAND
MARANTZ
Technischer Service
Duenstrasse 3
3186 Düringen
Switzerland

BELGIUM
SVD DIVISION MARANTZ
Industrialaan 1
1720 Groot-Bijgaarden
Belgium
Telex: 24466

FRANCE
MARANTZ FRANCE
4 Rue Bernard Palissy
92600 Asnières
France
Telex: 611651

GREECE
SHERTON ELECTRONICS S.A.
P.O.Box 21025
Hippocrates Street 188
Athens 11471
Greece
Telex: 216.795

SOUTH AFRICA
MARANTZ
DIVISION OF PHILIPS S.A.
Main Road Martindale
P.O. Box. 58088
Newville 21114
South Africa

TURKEY
DOGRUOL Ltd.
I.M.C.
6 Blok N°6310
Unkapani
Istanbul
Turkey
Telex: 22085

CHILE
MARANTZ
DIVISION OF PHILIPS S.A.
AV. Santa Maria, 0760
Casilla 2687
Santiago
Telex: 240.239

GERMANY
MARANTZ GERMANY GmbH
Alexanderstrasse 1
2000 Hamburg
Germany

JAPAN
MARANTZ JAPAN, Inc.
35-1, 7-chome, Sagamiono
Sagamihara-shi, Kanagawa
Japan

SPAIN
PHONO S.A.
Ignacio Iglesias 10
Badalona (Barcelona)
Spain
Telex: 59355

MALTA
CACHIA & GALEA
Republic Street, 68D
Valetta
Telex: 1682

DENMARK
MARANTZ
DIVISION OF PHILIPS
SERVICE A/S
Prags Boulevard 80
Postbox 1919
DK-2300 København S
Denmark
Telex: 31201

THE NETHERLANDS
Elpro Marantz
Wint Hontlaan 28
3526 KV Utrecht
The Netherlands
Telex: 4748

KUWAIT
AL ALAMIAH ELECTRONICS
Ussama Building
Fahd al Saleem Street
P.O.Box 23781
Safat-Kuwait
Telex: 22694

SWEDEN
MARANTZ
DIVISION OF PHILIPS
Försäljning AB
Tegeluddsvägen 1
S-115 84 Stockholm
Sweden
Telex: 14060

PORTUGAL
MARANTZ
Divisao philips S.A. service
Ourela-carnaxide
2795 LinDA-A-VELHA
Telex: 43906

NORWAY
MARANTZ
DIVISION OF PHILIPS A/S
Sandstuveien 40
0680 Oslo 6
Norway
Telex: 72640

ITALY
MARANTZ ITALIANA S.P.A.
Via Chiese, 74
20126 Milano
Italy

All of the above locations are fully equipped to take care of your total service needs. Because various countries have differing configuration requirements, it is necessary that you contact the service facility in your particular country. In the event that there is no service location listed for your country, please, contact the nearest facility for the necessary assistance.

In case of difficulties, do not hesitate to contact the Technical Department at abovementioned address.

TECHNICAL SPECIFICATIONS (DIN)

Power output

FTC 8Ω (20Hz – 20 kHz) 100/25W (Class A)
 DIN 8Ω/4Ω 120/170W

IHF dynamic power

8Ω/4Ω /2Ω 135/220/260W
 THD at 8Ω RMC rated output 0.008%
 Intermodulation distortion 0.008%
 Damping factor 120

Magnetic cartridge input

Input sensitivity impedance 2.5mV/47k Ω
 Accuracy of frequency response to IEC RIAA 0.5dB
 Signal to noise ratio 84dB

Moving coil cartridge input

Input sensitivity impedance250 μV/100 Ω
 Signal to noise ratio 74dB

Tuner/CD/Aux/Tape inputs

Input sensitivity impedance 150mV/33k Ω
 Signal to noise ratio 86dB
 Frequency response (-3 dB limits) 10Hz-100KHz
 Tone characteristic (100Hz/10KHZ) ±6dB
 Channel separation (1kHz/10KHz) > 85/> 65dB

General

Power Requirements
 00/02 versions 230V AC, 50/60Hz
 05/07 versions 240V AC, 50/60Hz
 01 versions (4 voltages) 110/120/220/240V AC, 50/60Hz

Dimensions (w/side panel)
 Panel Width 454mm
 Panel Height 164mm
 Depth 380mm

Weight
 Unit alone 17kg

Dimensions
 Panel Width 420mm
 Panel Height 162mm
 Depth 380mm

Weight
 Unit alone 13Kg

Specifications subject to change without prior notice.

1. BLOCK DIAGRAM

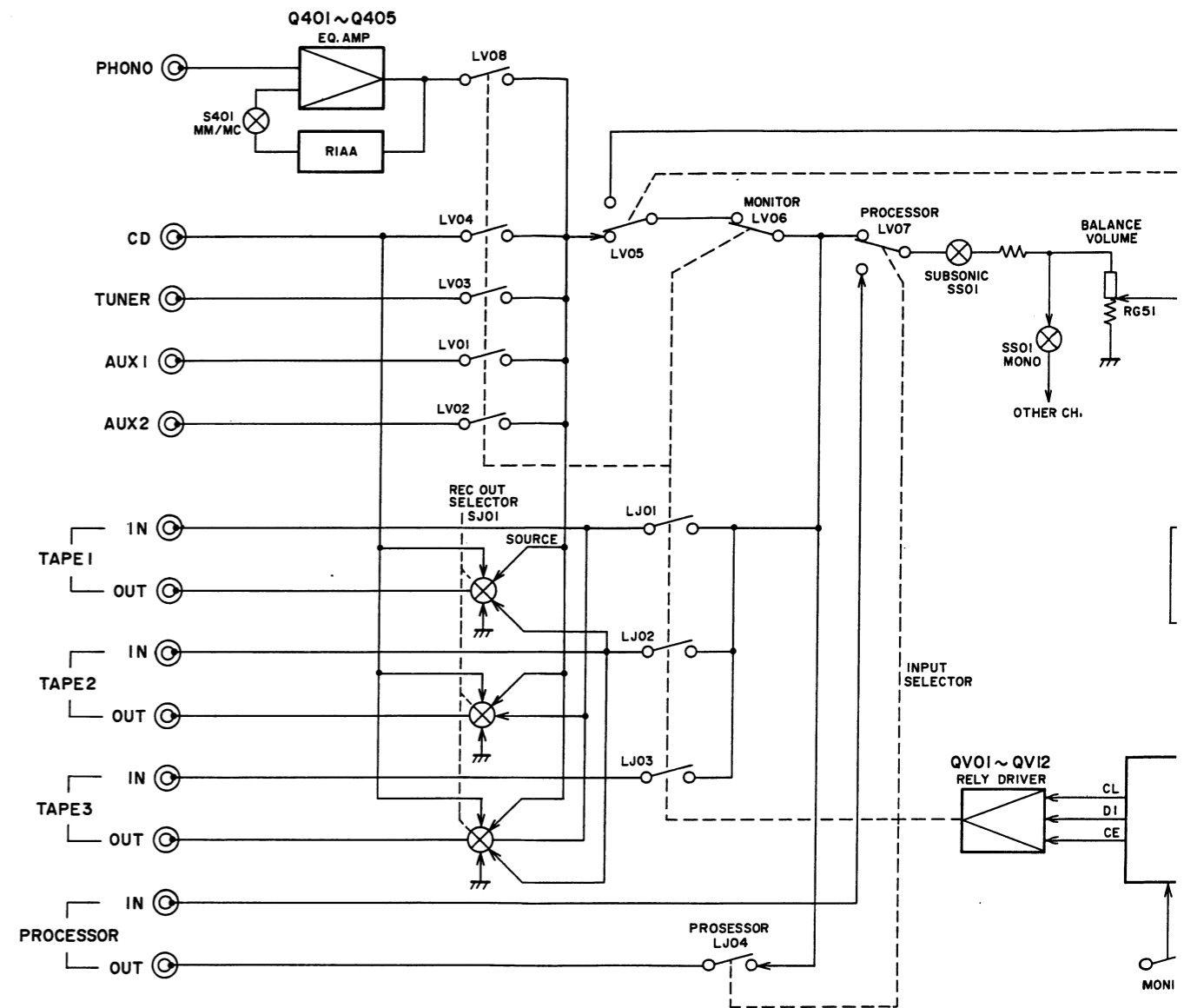

1. BLOCK DIAGRAM

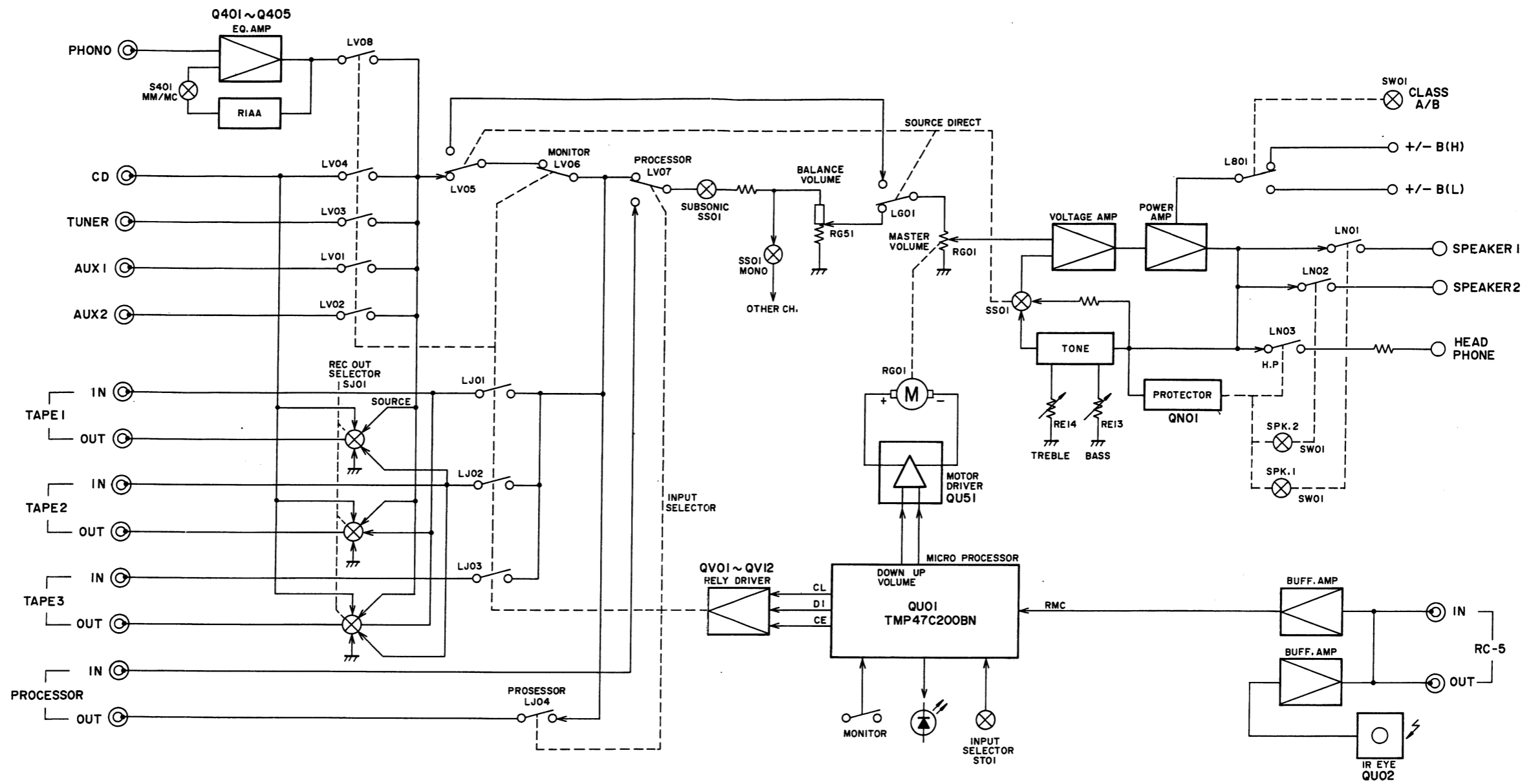

3ss A)
'170W

260W
008%
008%
. 120

47k Ω
0.5dB
84dB

100 Ω
74dB

33k Ω
86dB
0KHz
±6dB
65dB

60Hz
60Hz
60Hz

4mm
4mm
0mm

17kg

0mm
2mm
0mm

13Kg

2. SCHEMATIC DIAGRAM AND PARTS LOCATION (Pattern side)

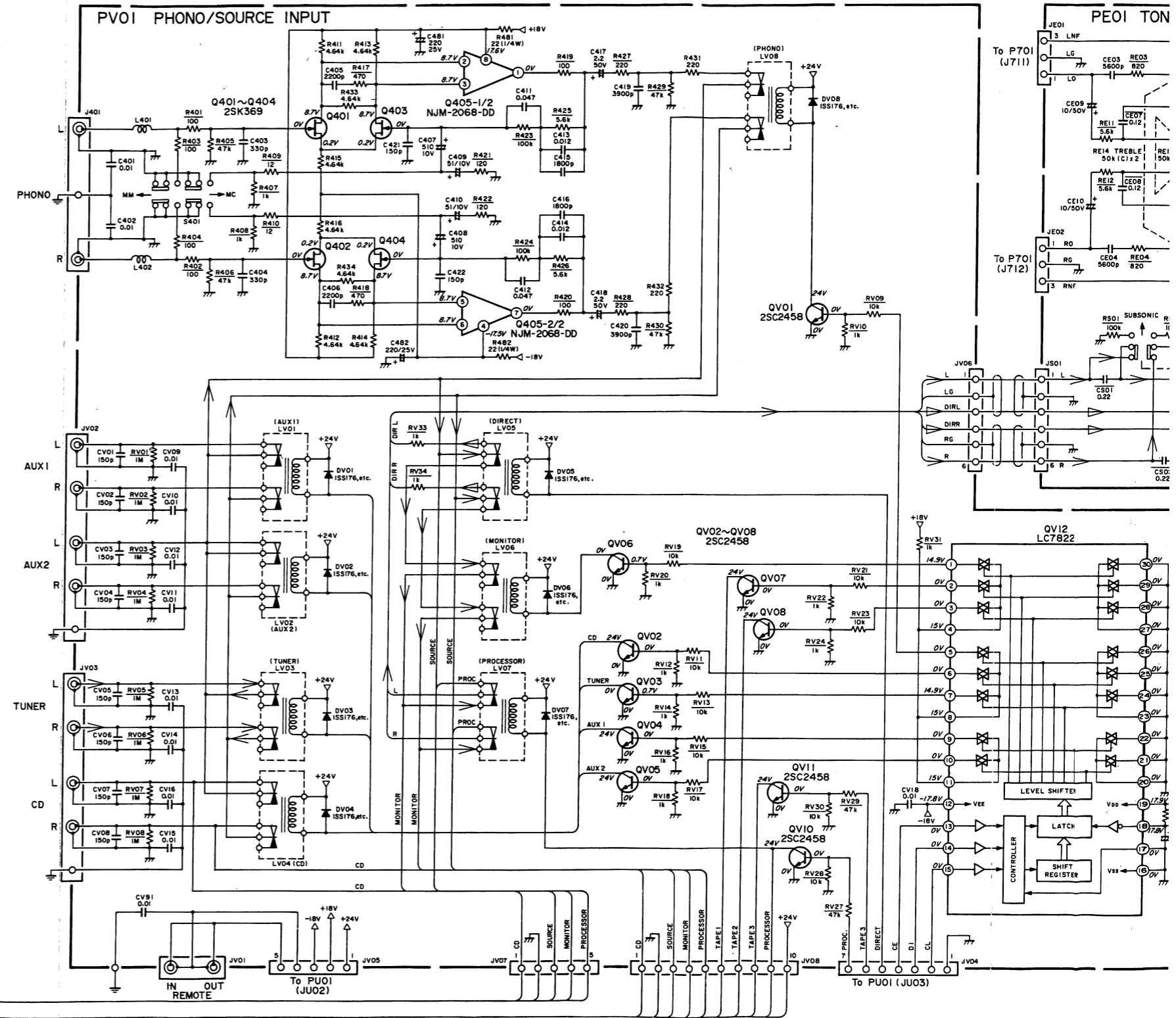
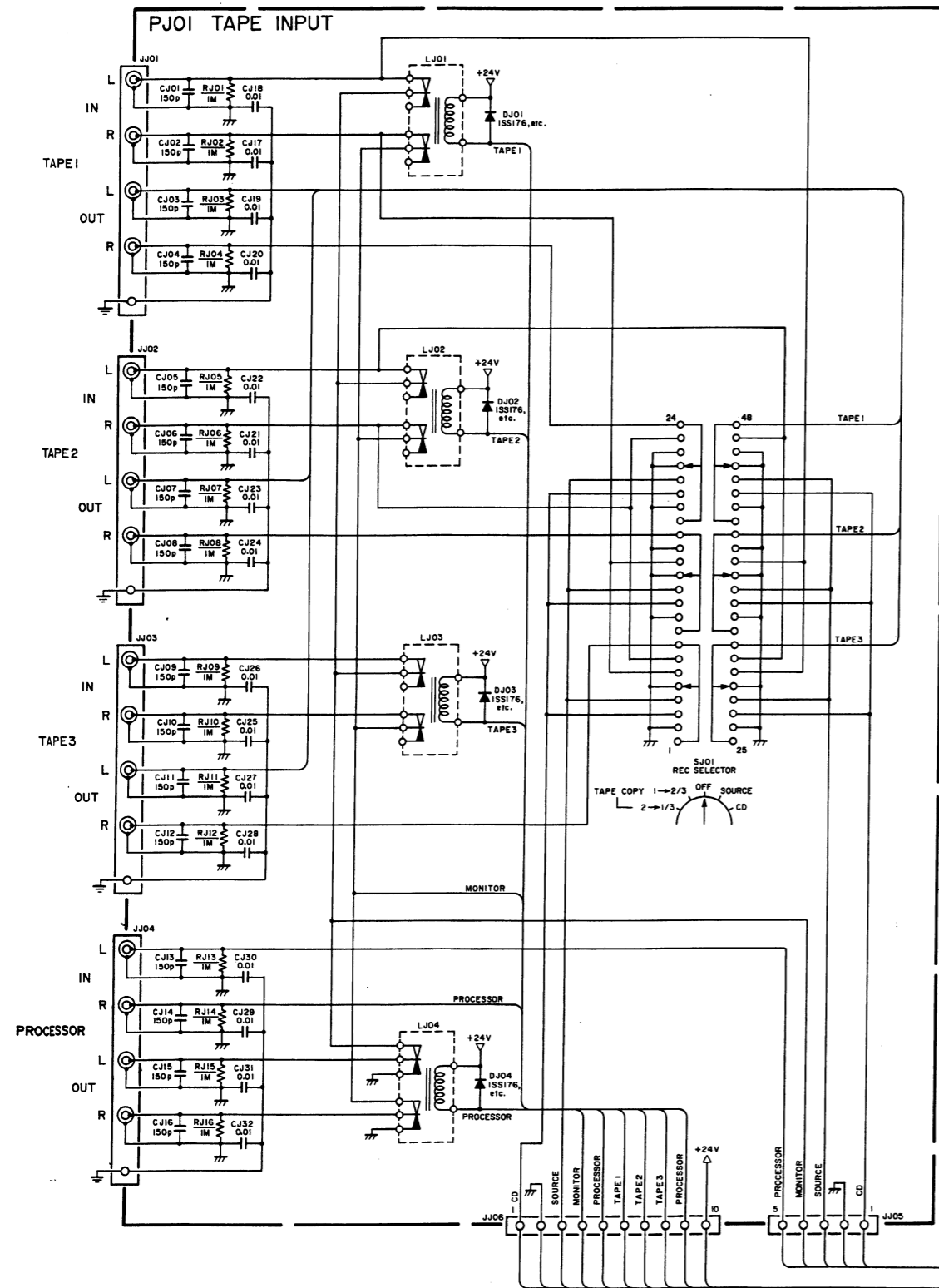

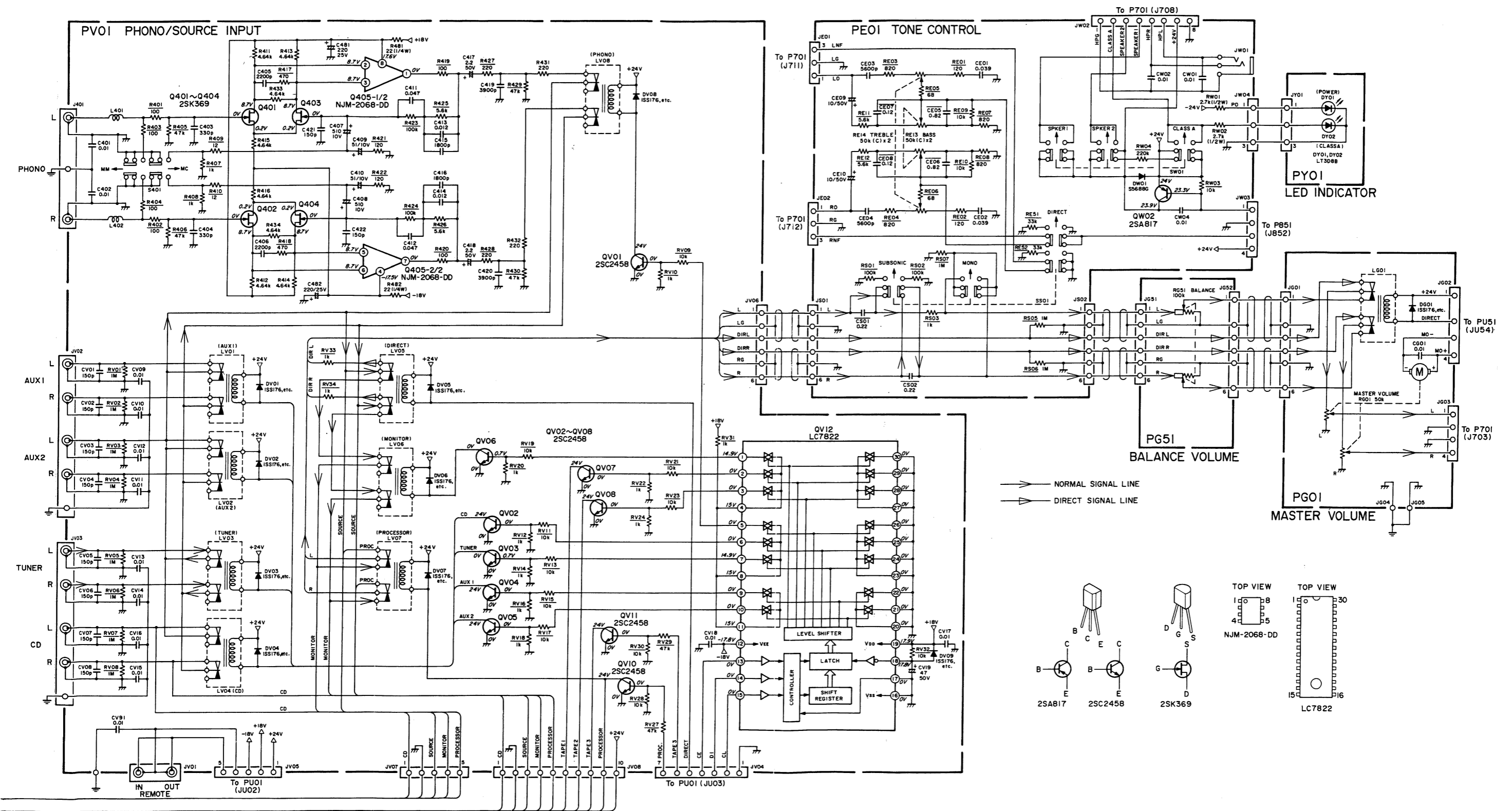

PV01

QV10~QV12 QV01~QV08

Q405

Q401~Q404

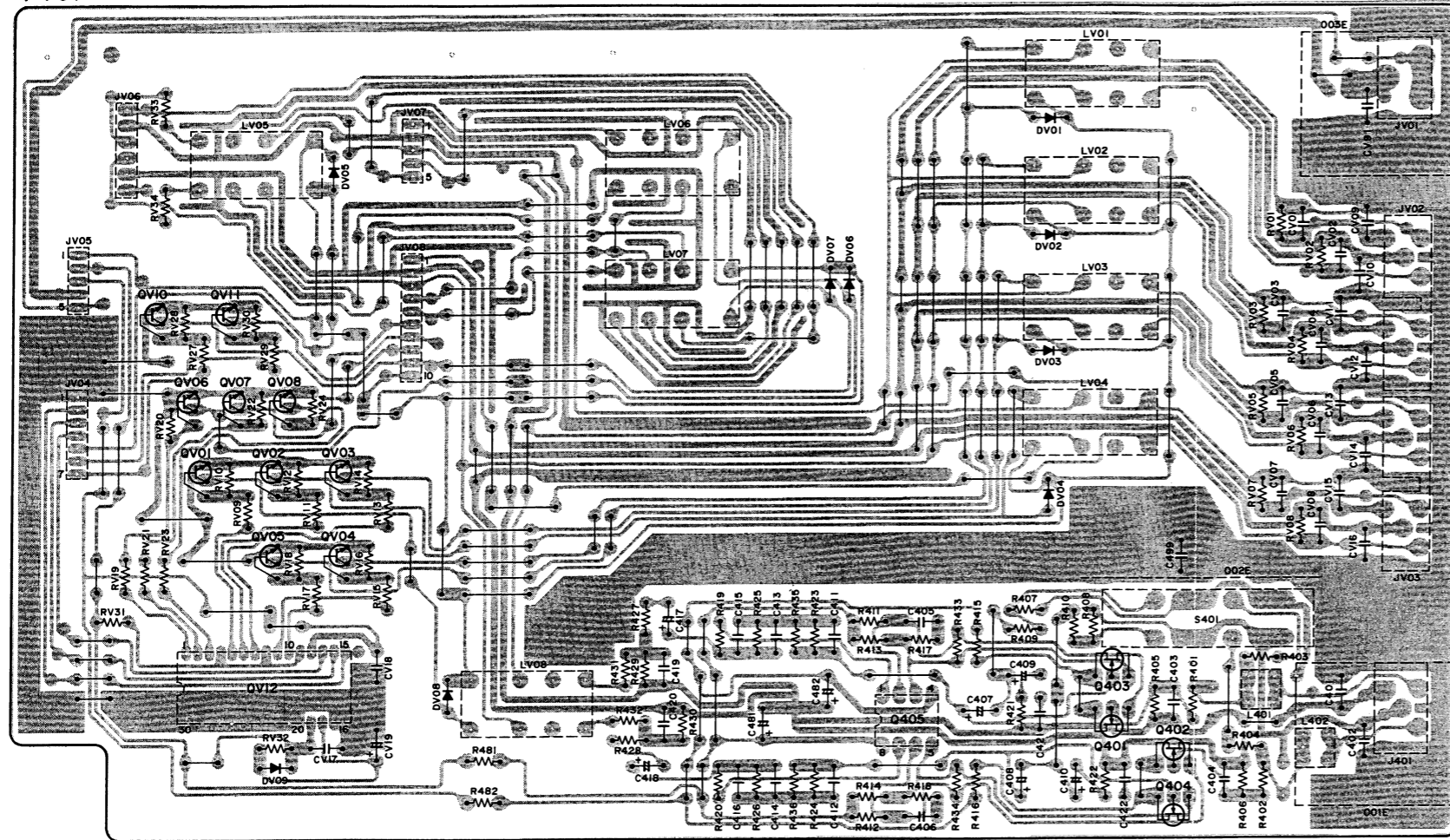

PJ01

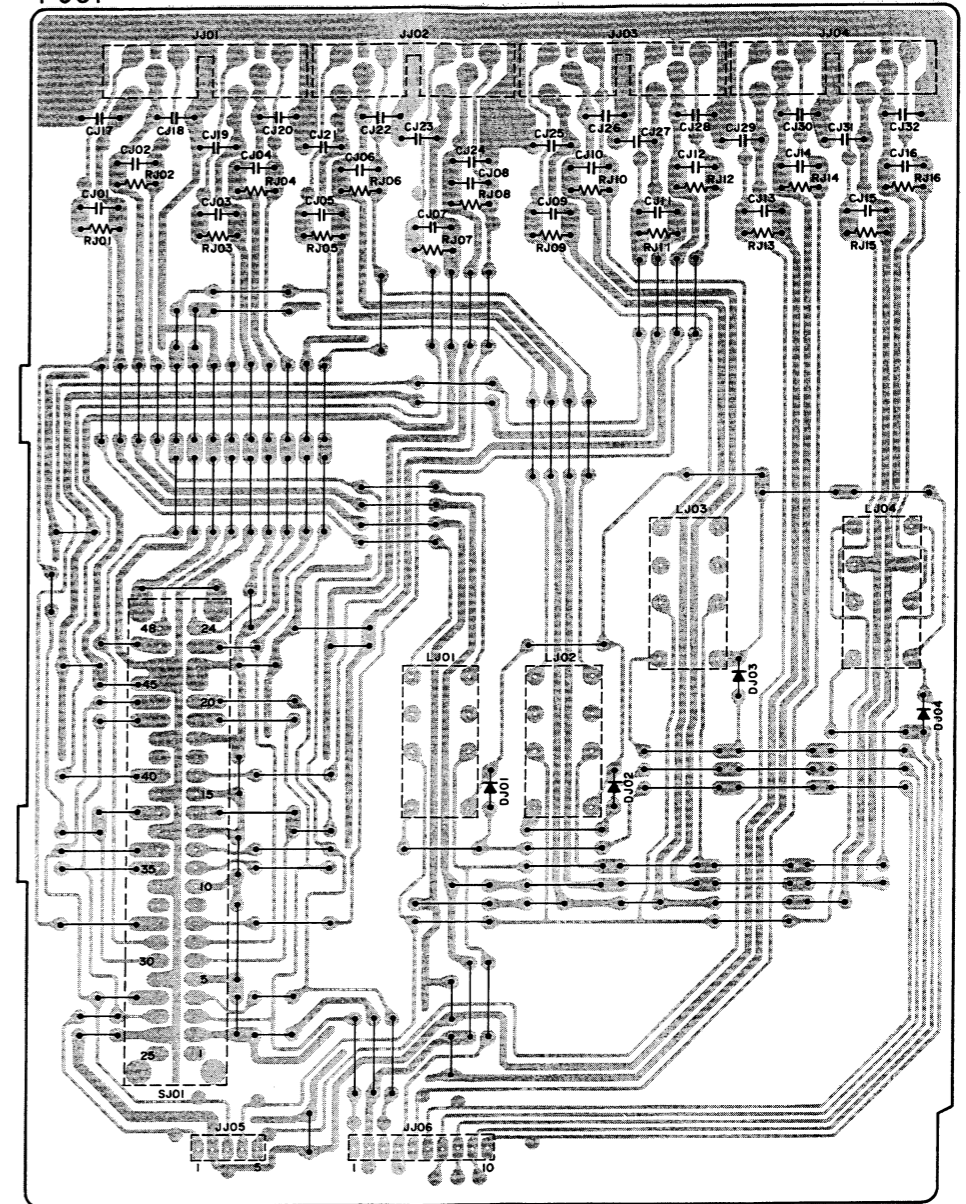

PY01

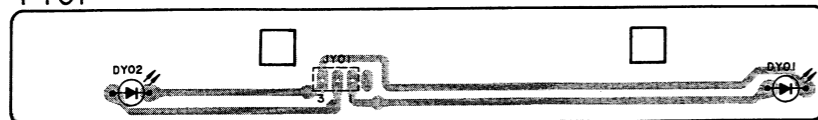

PG51

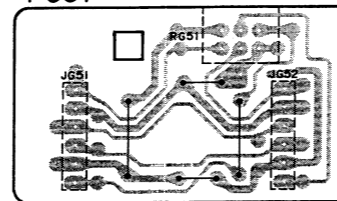

PE01

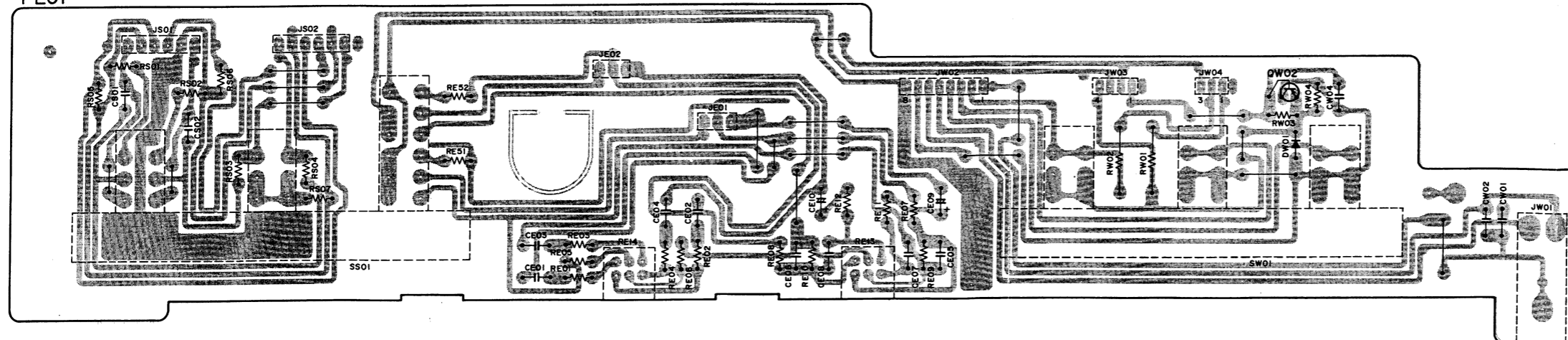

QW02

PG01

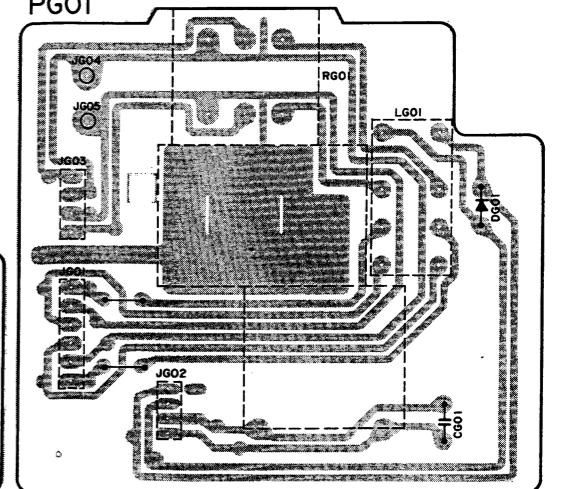

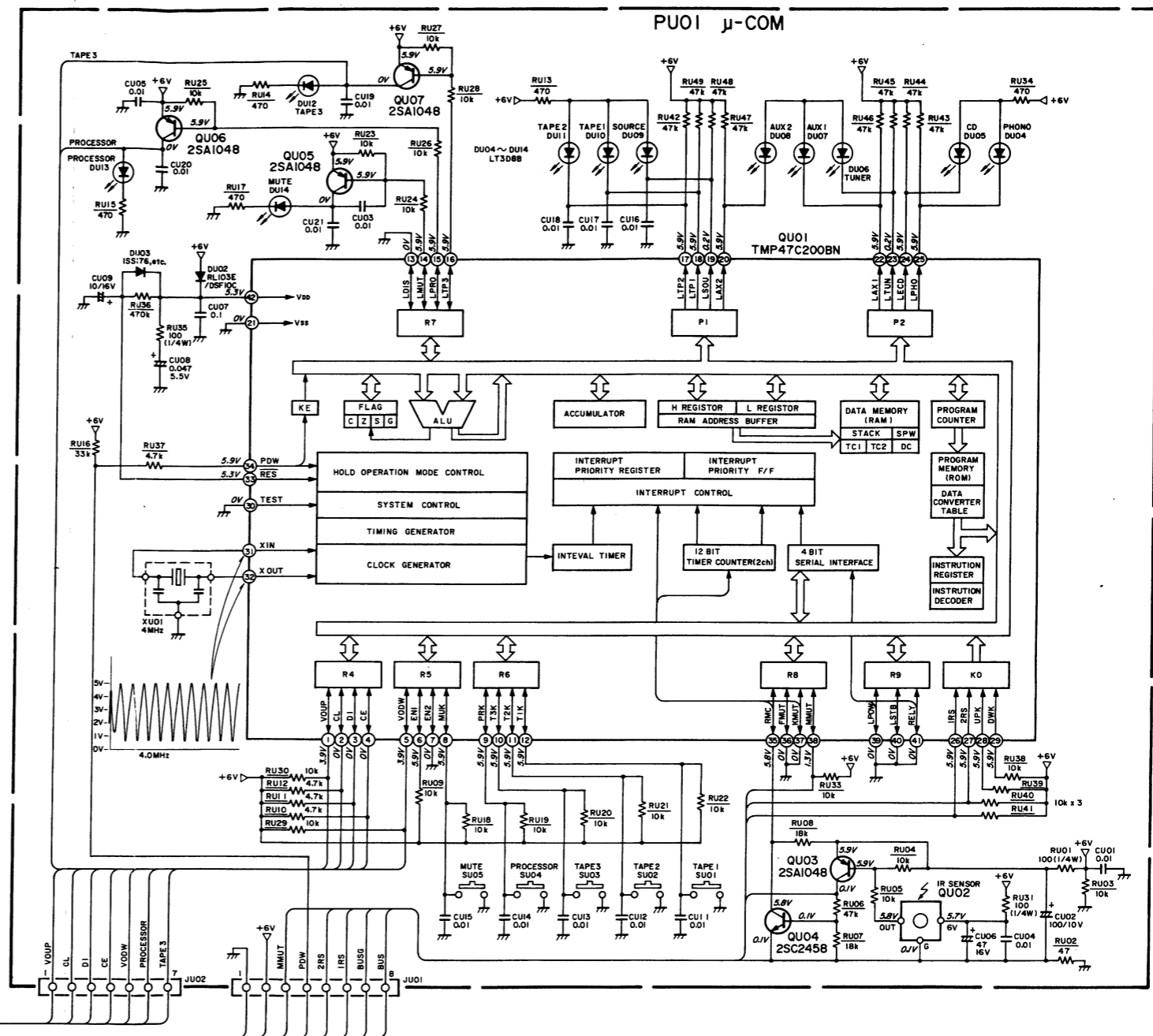
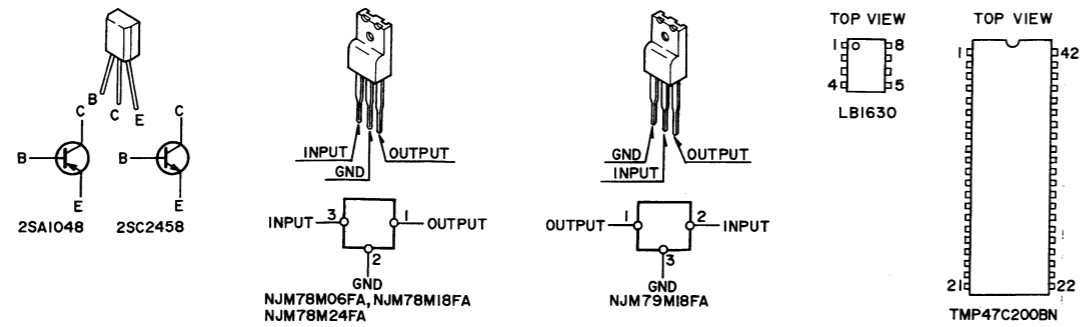
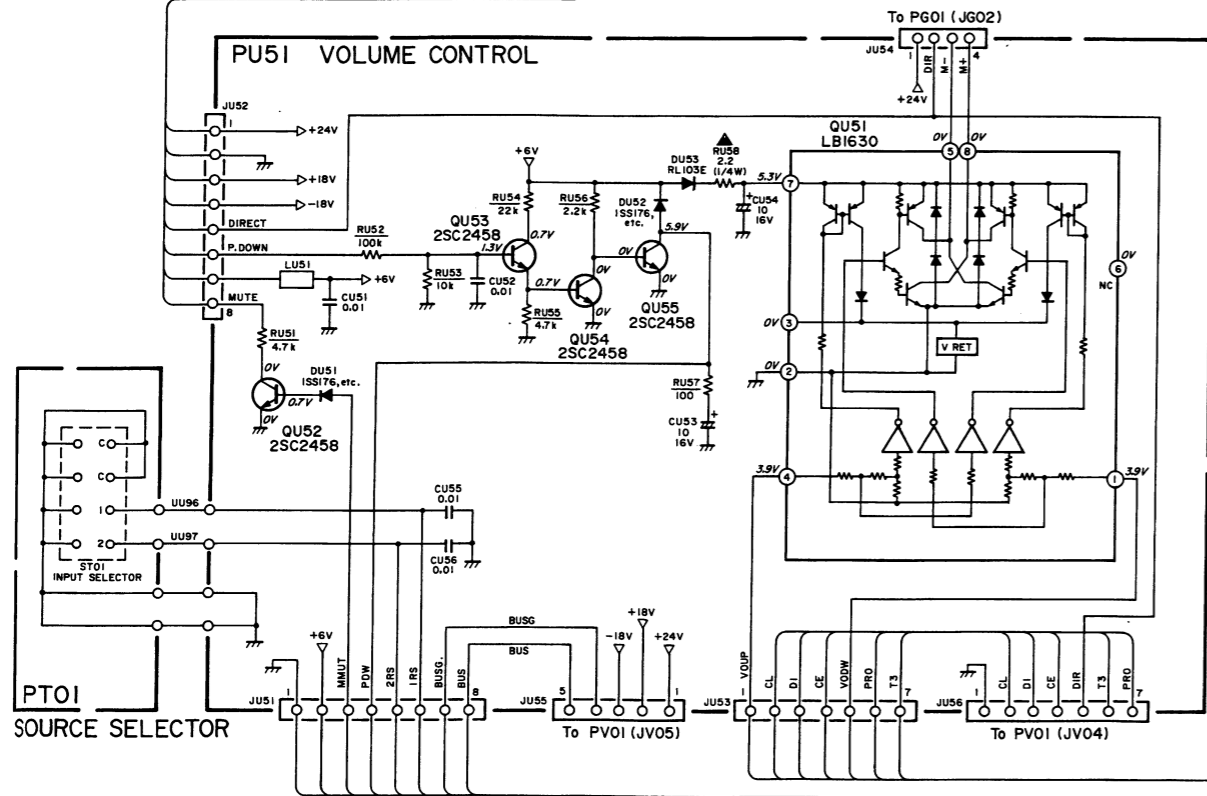
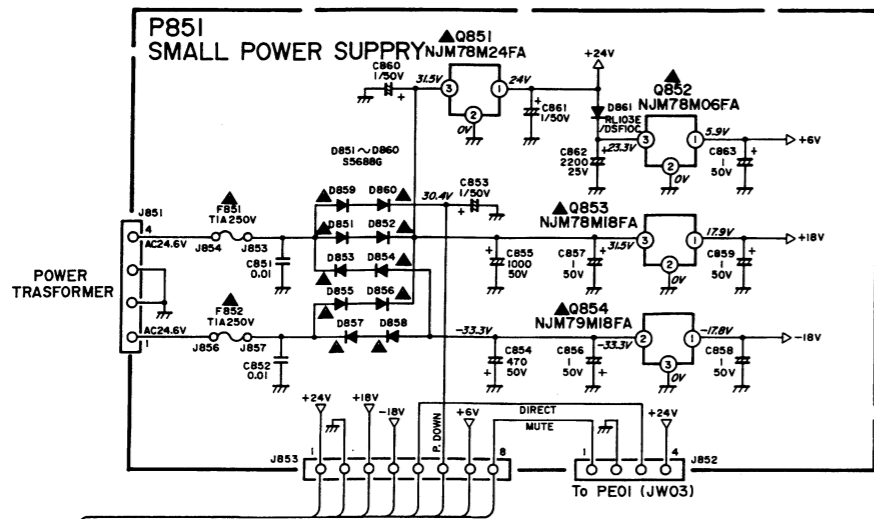

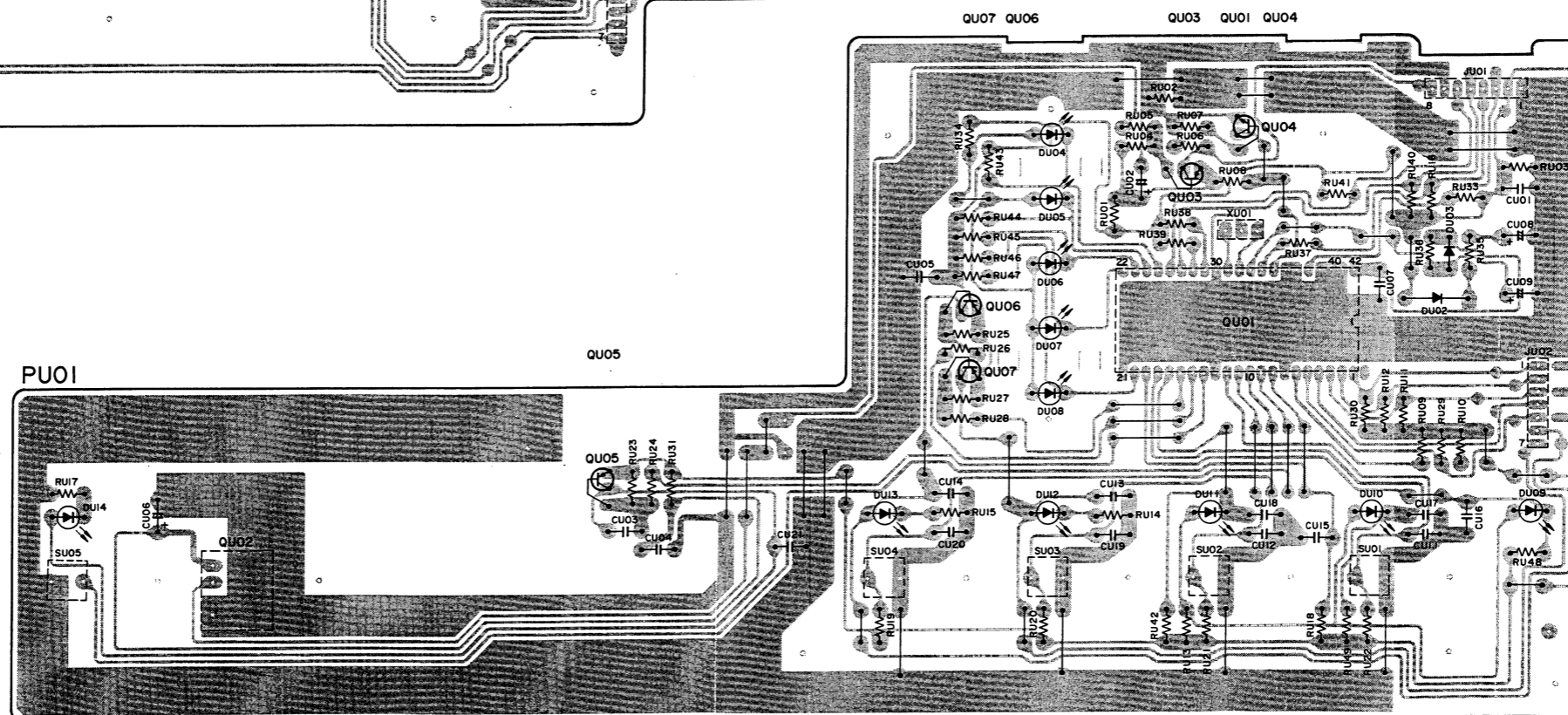
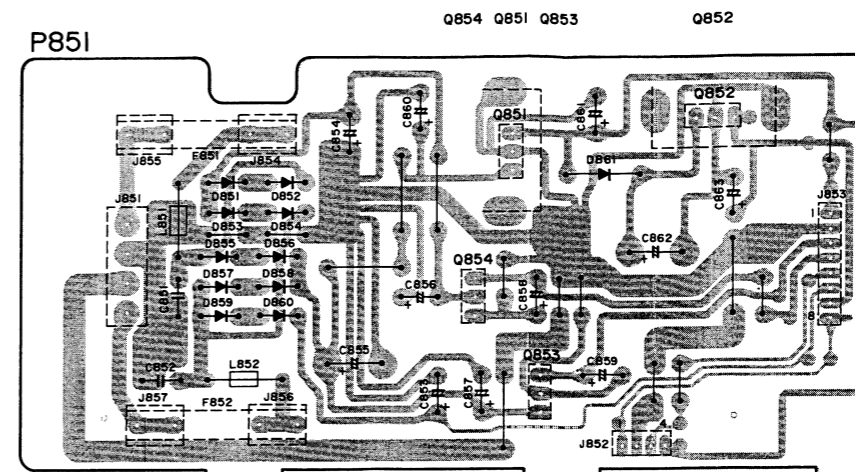
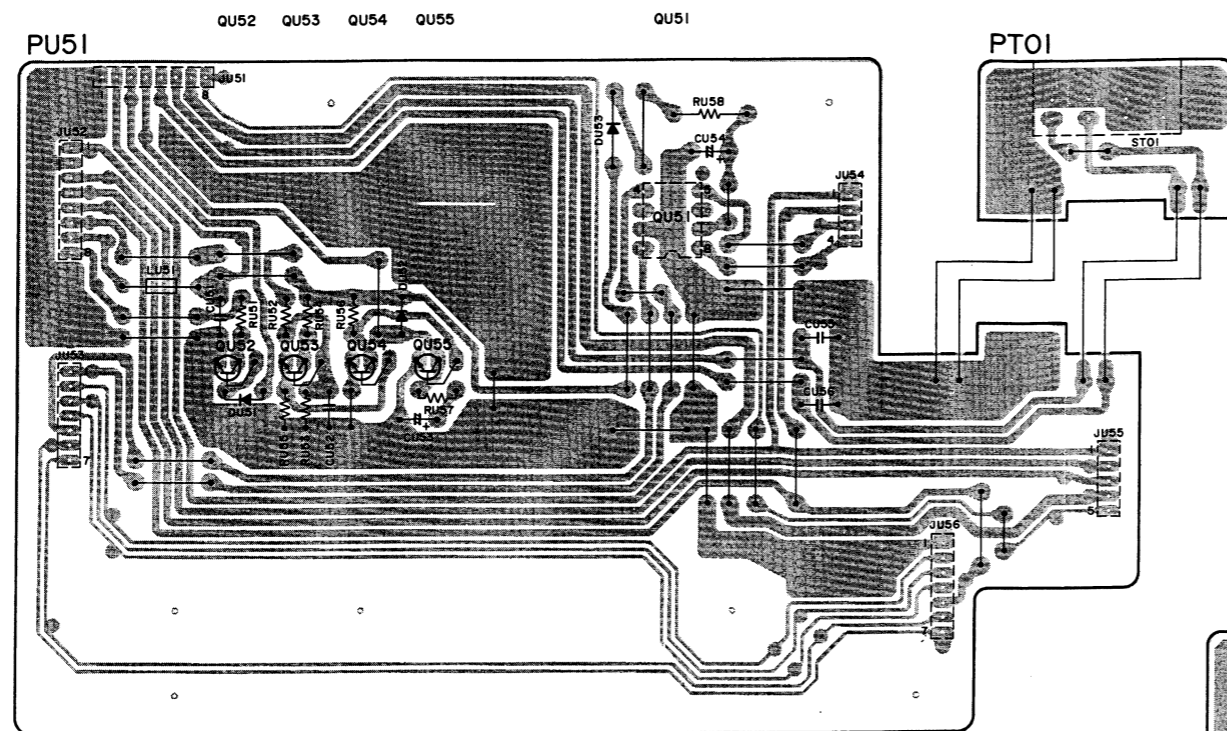

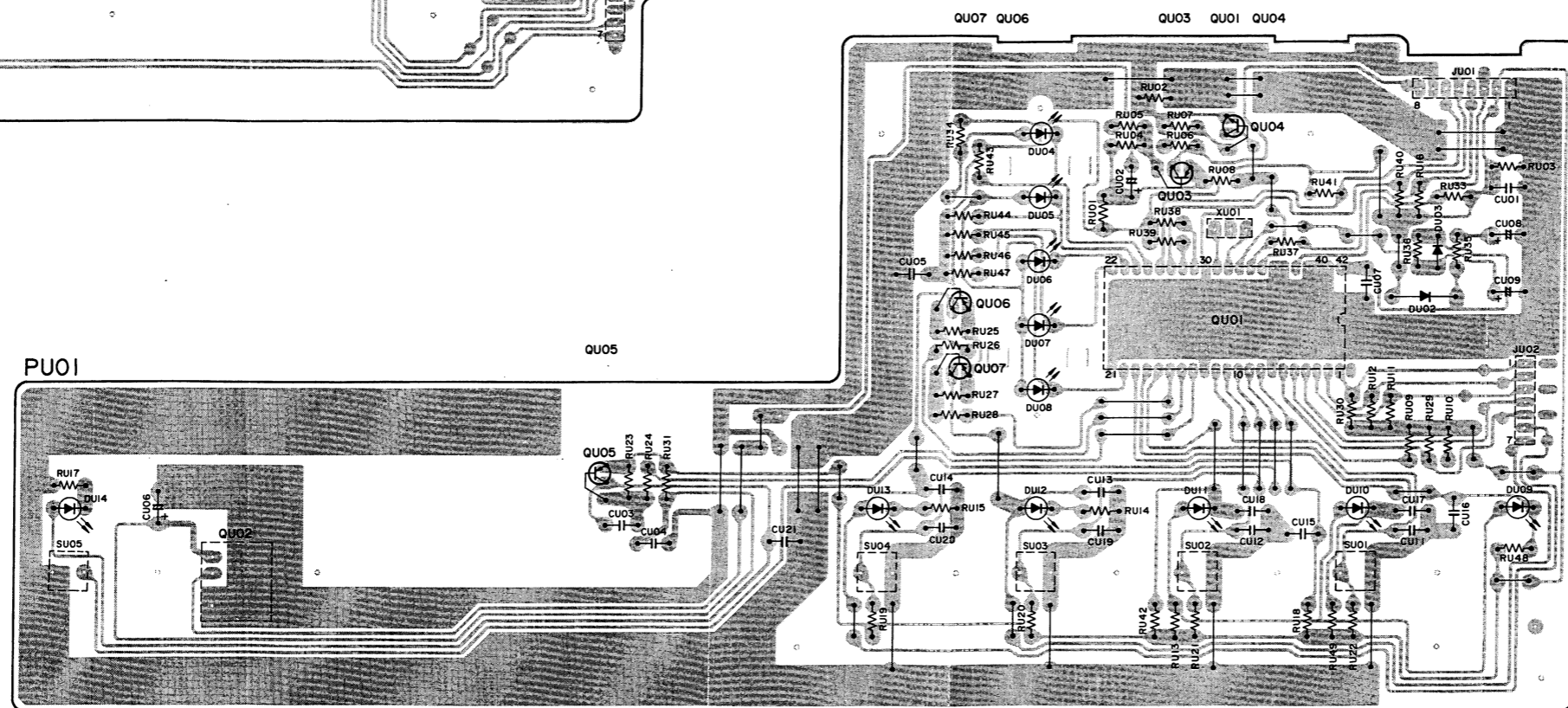
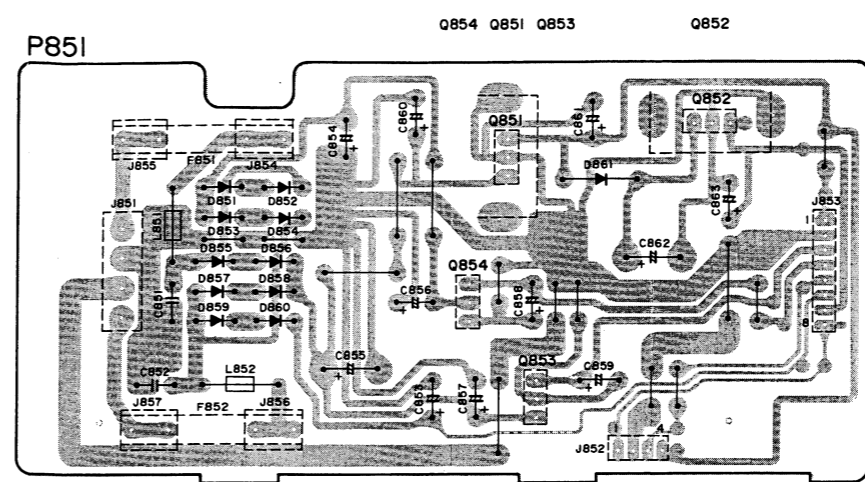
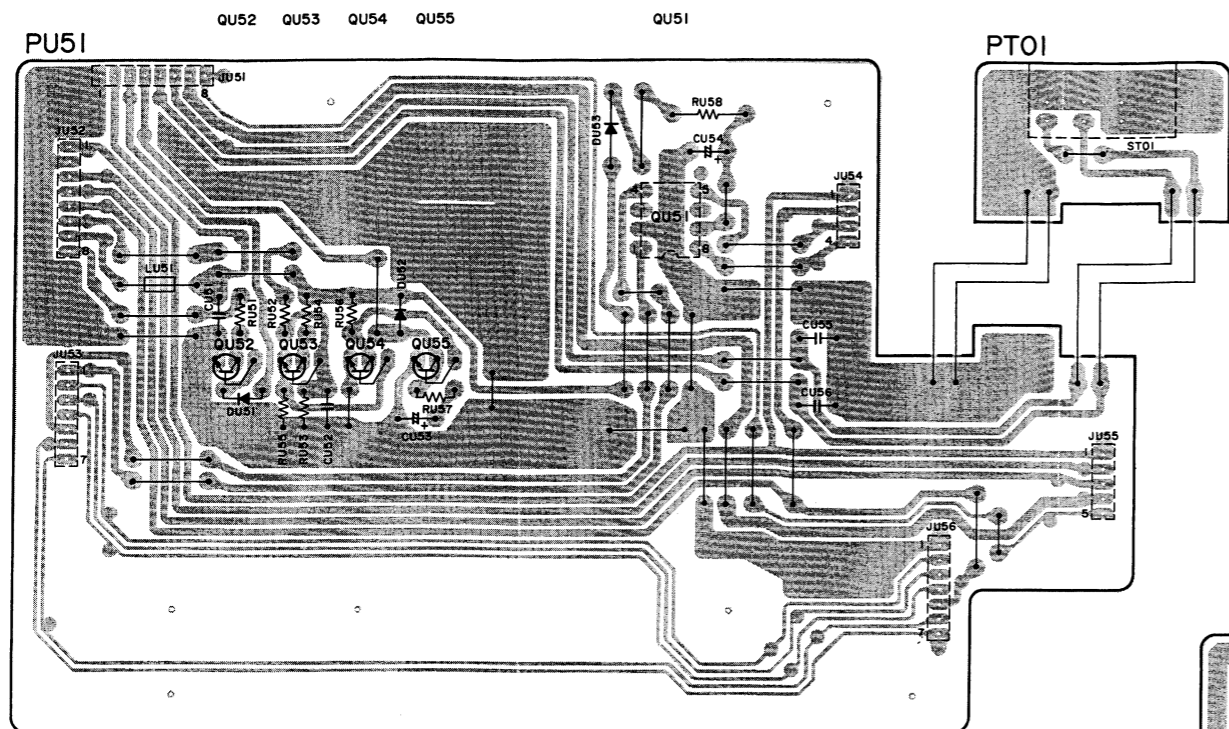

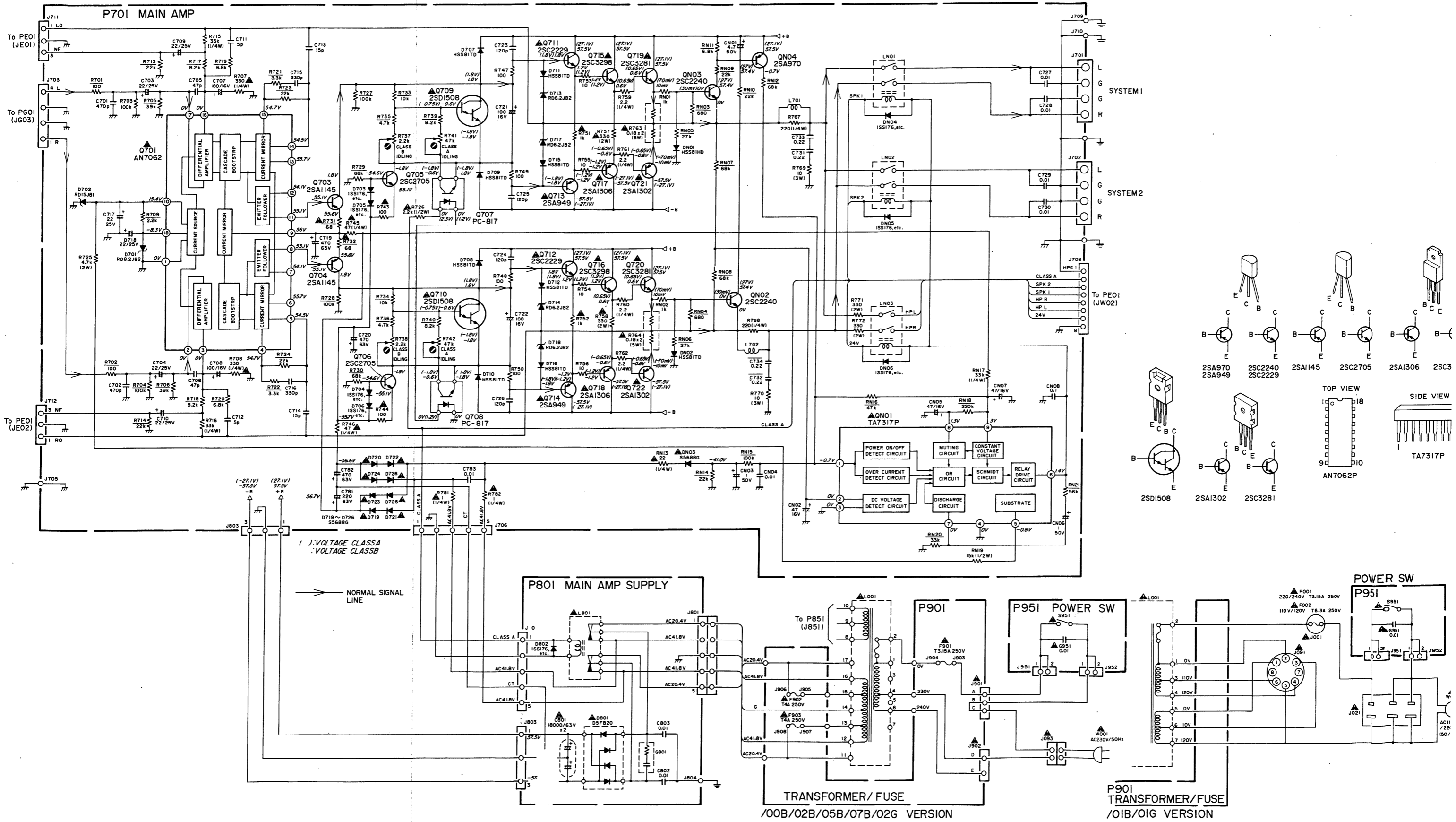

() VOLTAGE CLASS A
 () VOLTAGE CLASS B

➔ NORMAL SIGNAL LINE

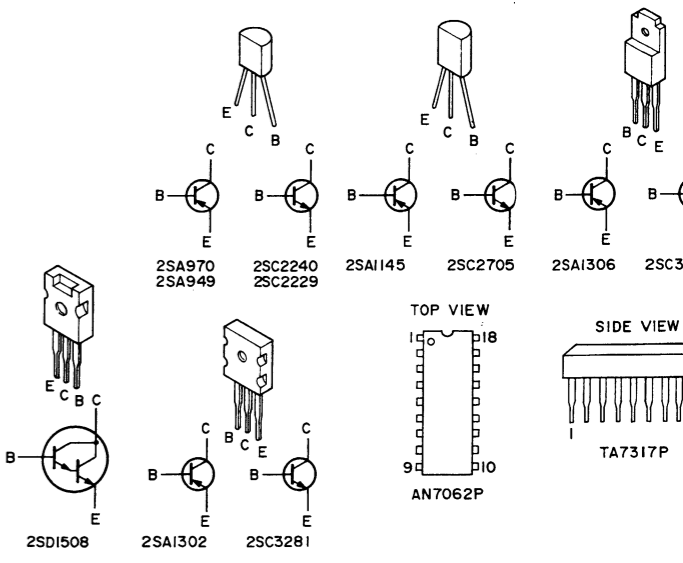

I MAIN AMP

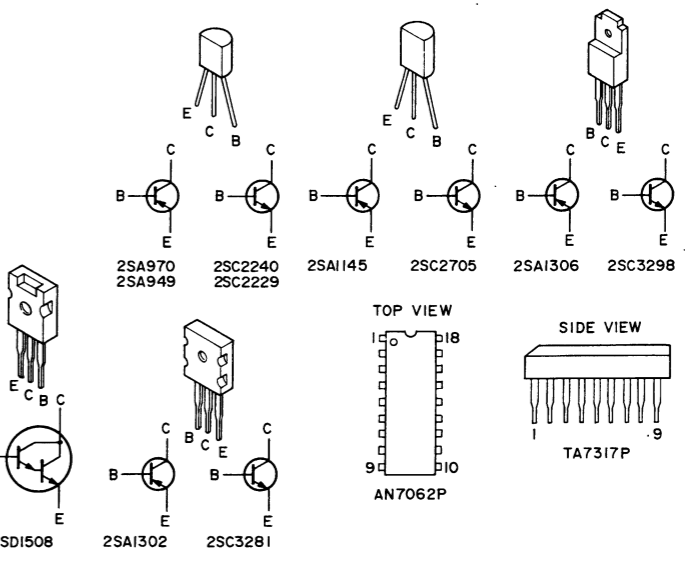
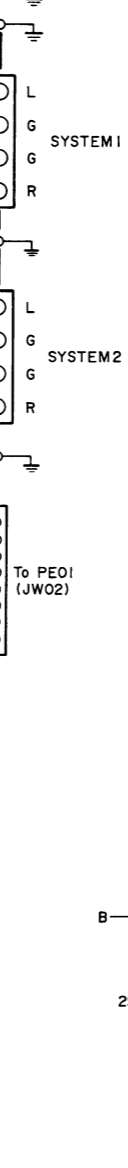
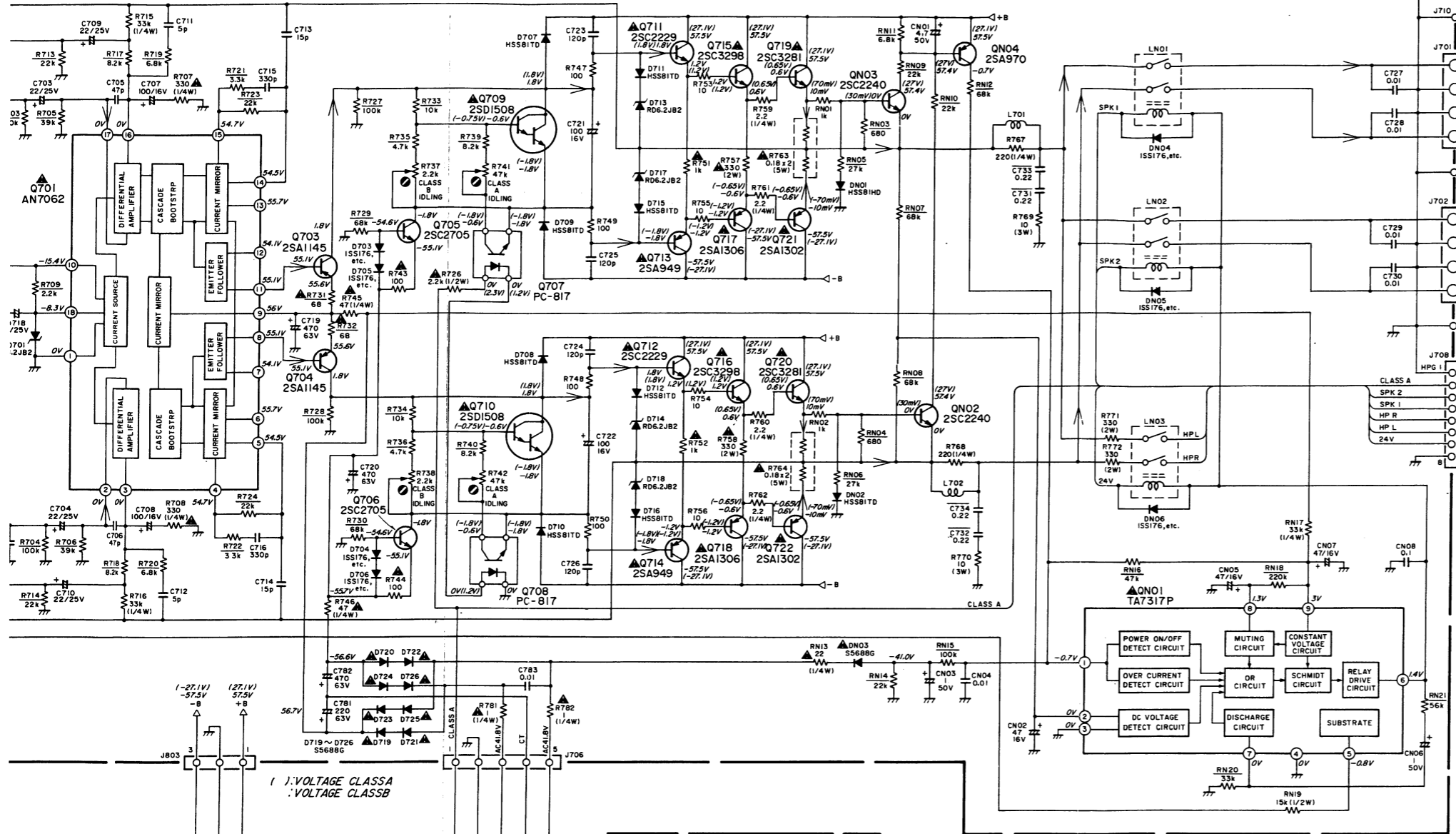

VOLTAGE CLASS A
VOLTAGE CLASS B

NORMAL SIGNAL LINE

P801 MAIN AMP SUPPLY

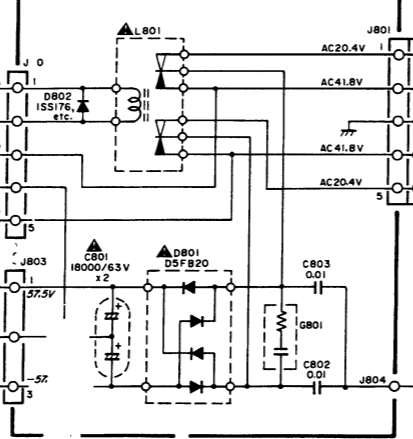

TRANSFORMER/FUSE
/00B/02B/05B/07B/02G VERSION

P901

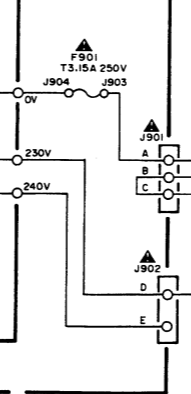

P951 POWER SW

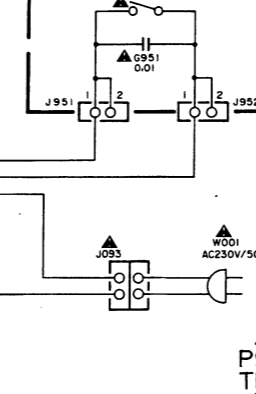

P901 TRANSFORMER/FUSE
/01B/01G VERSION

Q701 Q703~Q706 Q721 Q722 Q717 Q718 Q713 Q714 Q707~Q710 Q711 Q712 Q715 Q716 Q719 Q720 QN04 QN01~QN03

P701

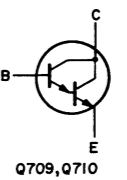
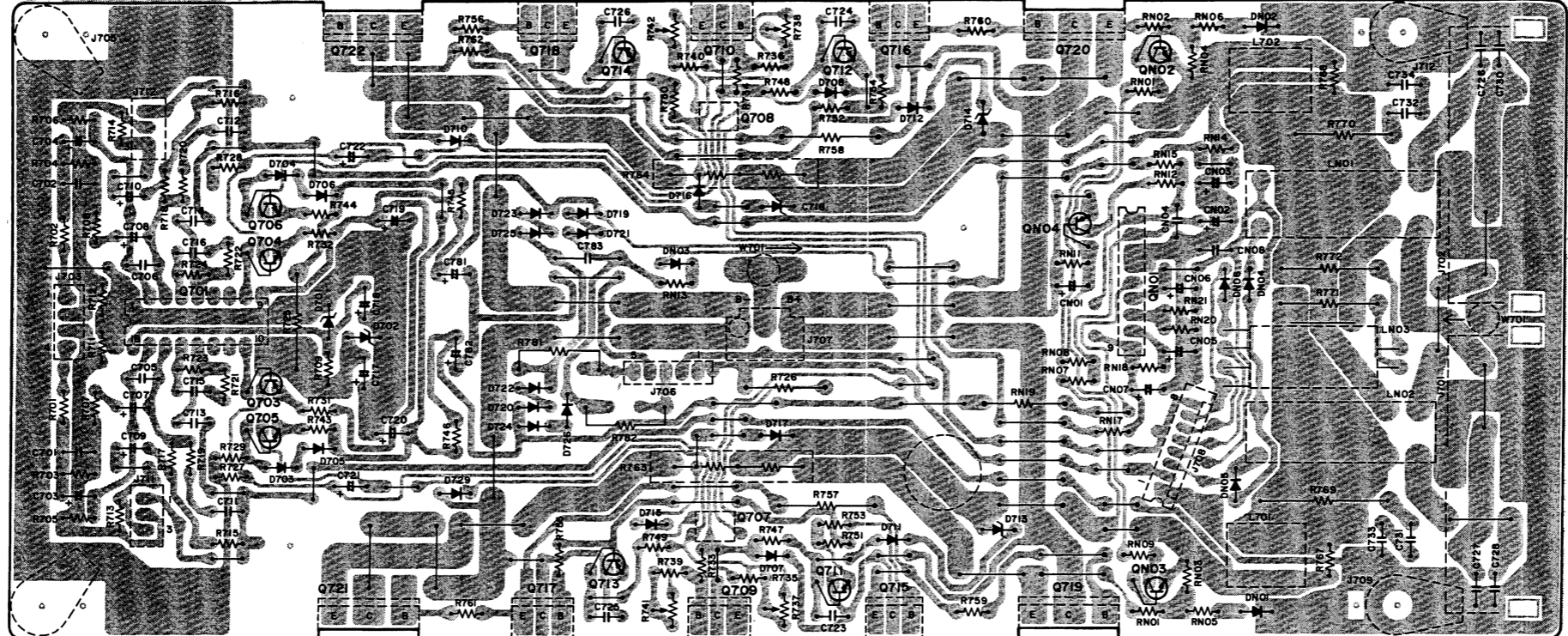

P801

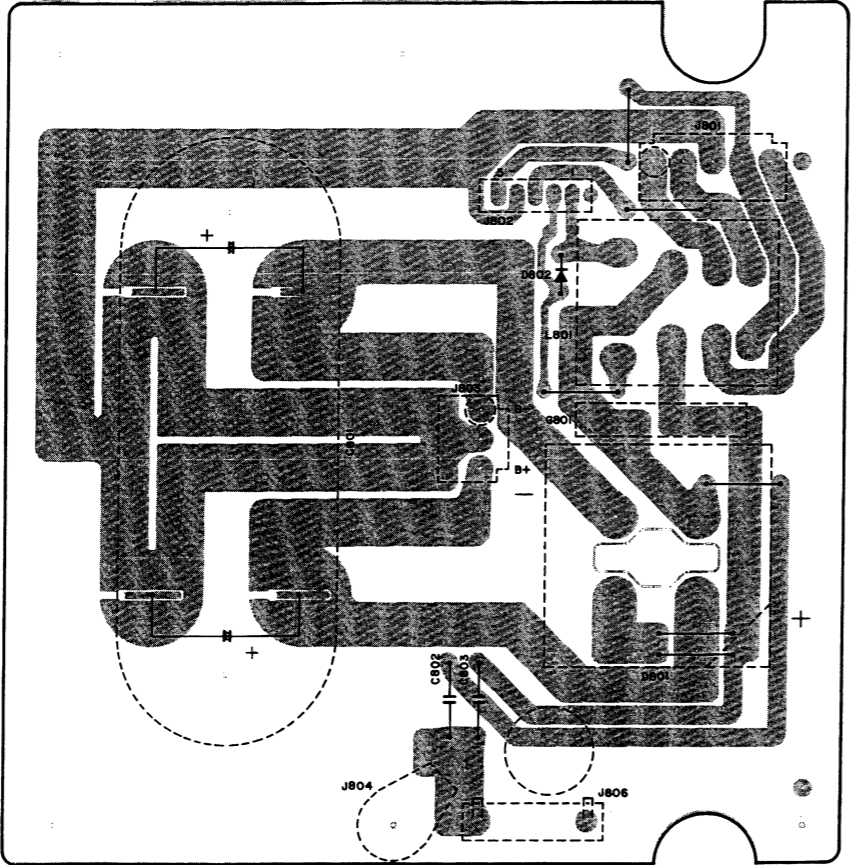

P951

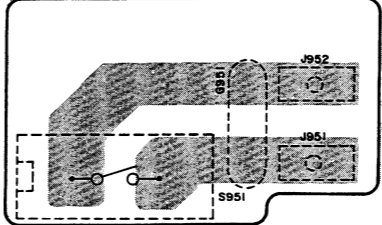

P901

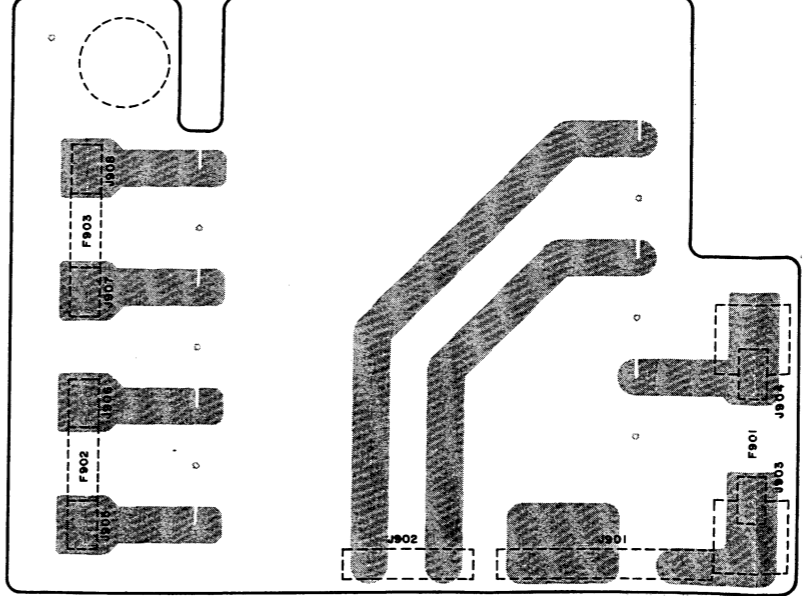

3. EXPLODED VIEW AND PARTS LIST

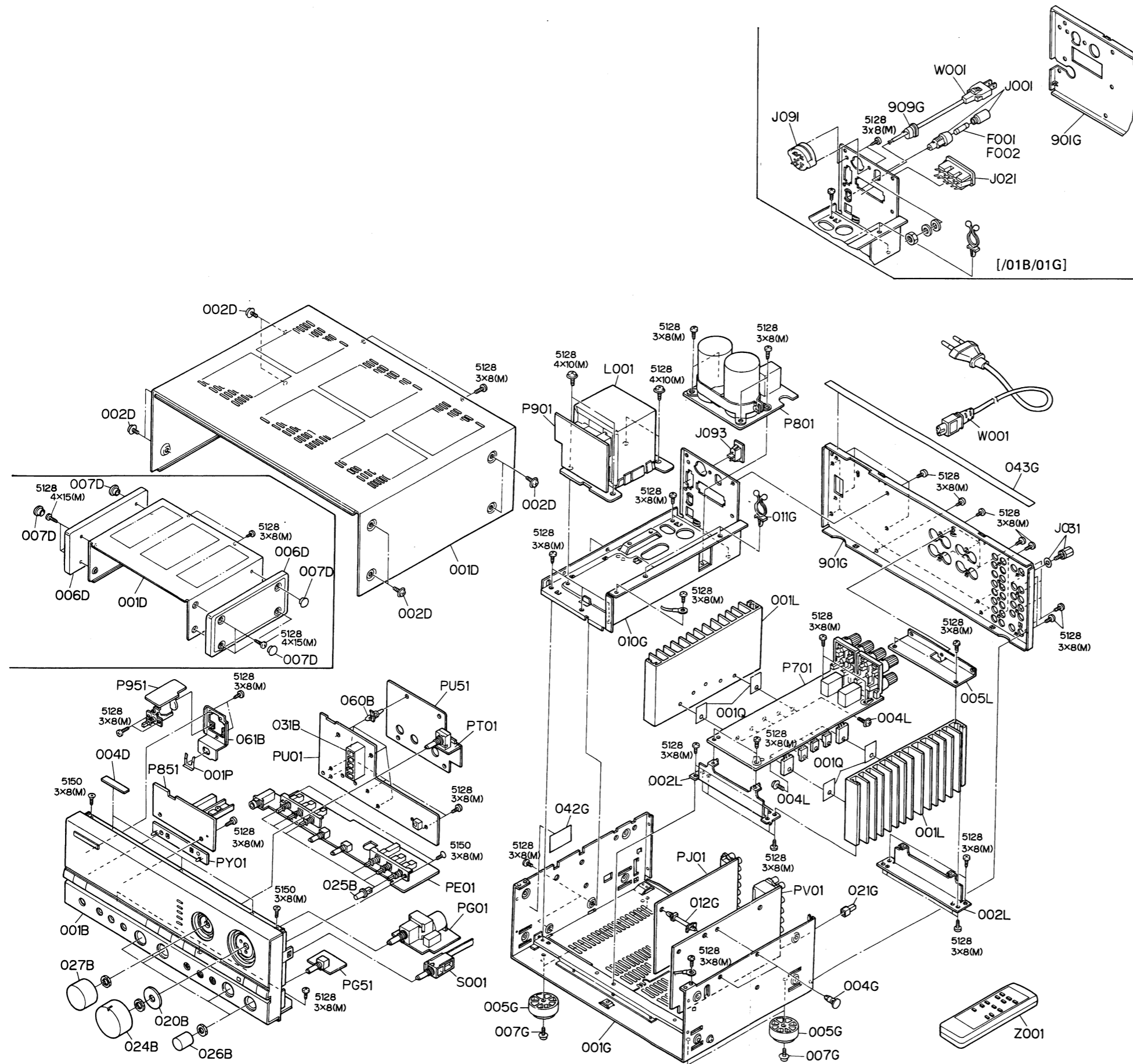

REF DESIG.	PART NO	DESCRIPTION
001B	4822 426 51581	Front Panel Assembly [00B/01B/02B/05B/07B]
024B	4822 426 51584 4822 413 41679	Front Panel Assembly [01G/02G] Knob, Volume [00B/01B/02B/05B/07B]
025B	4822 413 41683 4822 410 60343	Knob, Volume [01G/02G] Button, Push [00B/01B/02B/05B/07B]
026B	4822 410 60334 4822 413 41678	Button, Push [01G/02G] Knob, Rec/ Tone/ Bal. [00B/01B/02B/05B/07B]
027B	4822 413 41682 4822 413 41745	Knob, Rec/ Tone/ Bal. [01G/02G] Knob, Selector [00B/01B/02B/05B/07B]
031B	4822 413 41752 4822 380 20442	Knob, Selector [01G/02G] Reflector
006D	4822 426 30148	Side Panel [01G/02G]
007D	4822 444 60607	Cap [01G/02G]
005G	4822 462 41383	Leg
021G	4822 412 20506	Knob, MM/ MC
909G	4822 532 52145	Bushing, AC Cord [01G/02G]
001Q	4822 466 92249	Insulator, DENKA Sheet
▲ F001	4822 070 33152	Fuse 3.15A 250V [01B/01G]
▲ F002	4822 253 30243	Fuse 6.3A 250V [01B/01G]
▲ J001	4822 256 30233	Fuse Holder [01B/01G]
▲ J021	4822 267 40663	AC Outlet 3P [01B/01G]
J031	4822 267 31544	Ground Terminal
▲ J091	4822 272 10227	Voltage Selector [01B/01G]
▲ J092	4822 265 10092	Jack, AC Adapter [01B/01G]
▲ J093	4822 267 30986	Plug, AC Inlet [02G/02B/05B/07B/00B]
▲ L001	4822 146 21691	Power Transformer [00B/02B/05B/07B/02G]
	4822 146 21692	Power Transformer [01B/01G]
S001	4822 273 10255	Switch, Rotary
001T	4822 736 21542	User Manual
Z001	4822 218 10479	Remote Control

4. TEST EQUIPMENT REQUIRED FOR SERVICING

Item	Use
Distortion Analyzer	Distortion measurements
Audio Oscillator	Sinewave and squarewave signal source
ACVTVM	Voltage measurements (AC)
Oscilloscope	Waveform analysis and trouble shooting and ASO alignment
Circuit Tester	Trouble shooting
DCVTVM	Voltage measurements (DC)
AC Wattmeter	Monitors primary power to amplifier
Line Voltmeter	Monitors potential of primary power to amplifier
Variable Autotransformer	Adjust level of primary power to amplifier
Shorting Plug	Shorts amplifier input to eliminate noise pickup

5. IDLING CURRENT ADJUSTMENT

- Before switching the power on, set the Master Volume control to the minimum position and the Balance and Tone controls to the center positions. Then, turn off the class-A Switch and set the semi-fixed resistors R737 (Lch) and R738 (Rch) on the PC board P701 to the center positions.
- Each of the cement resistors R763 (Lch) and R764 (Rch) on the PC board is provided with three test points. Connect a Digital Voltmeter, set for the DC voltage input, to the test points at the two extremities of the three test points of R763 or R764.
- After the completion of the above setup, perform the class-B idling current adjustment as follows: Switch the power ON and adjust the semi-fixed resistors R737 (Lch) and R738 (Rch) on the PC board P701 according to the reading of the digital voltmeter. The setting values are 18m (50 mA) of the both channels.
- After the completion of the class-B idling current adjustment, perform the class-A current adjustment as follows: Press the class-A switch and adjust the semi-fixed resistors R741 (Lch) and R742 (Rch) on the PC board P701 to set 180 mV (500 mA).

Note: For idling current adjustment, be sure to perform first class-B, then class-A.

Please refer to the table below.

Elapsed time after power ON	Idling current setting value
30 sec. - 1 min.	16.5 mV
1 min. - 2 min.	19.5 mV
2 min. - 4 min.	21.5 mV
More than 10 min	18.0 mV

Elapsed time after class-A switch ON	Idling current setting value
20 sec. - 1 min.	195 mV
1 min. - 2 min.	185 mV
More than 2 min.	180 mV

Note on Safety:

Symbol ▲ Fire or electrical shock hazard. Only original parts should be used to replace any part marked with symbol ▲. Any other component substitution (other than original type), may increase risk of fire or electrical shock hazard.

6. VOLTAGE CONVERSION

● EUROPEAN MODEL ONLY

To convert the unit to a different power source voltage, change the position as illustrated in the drawing below.

VOLTAGE SELECTOR

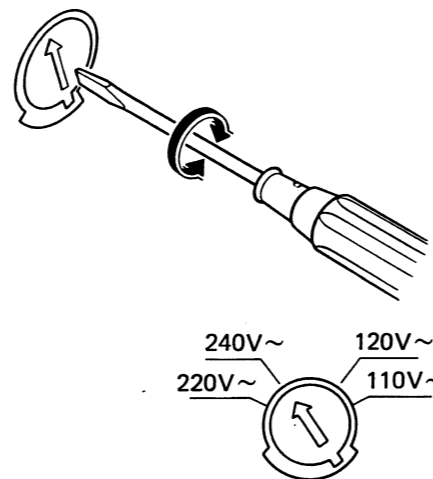

CAUTION
DISCONNECT POWER SUPPLY CORD FROM AC OUTLET BEFORE CONVERTING VOLTAGE.

7. HOW TO CHANGE THE SUPPLY VOLTAGE (/00/02/05/07 Versions)

With the /07 and /05 Versions, the rated supply voltage of 240V can be changed to 230V. In the same way, the 230V rated supply voltage of the /02 and /00 Versions can be changed to 240V.

Refer to the following diagram for the voltage change procedure.

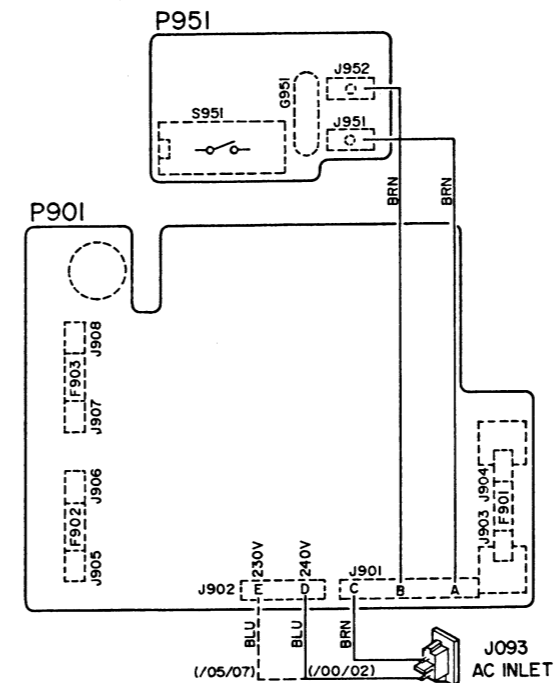

Soldered surface of P901

After binding solder around the terminal, bundle the brown wire and blue wire together and tighten them with a tightener.

● Note on Terminals J901 and J902

Wrapping terminals J901 and J902 on the P901 PC board are critical components for the safety. Please observe the following caution when working these terminals.

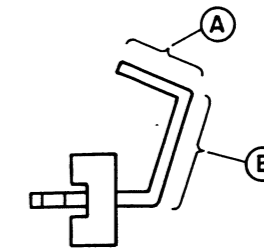

Terminal side view

Wrapping shall be performed within range A. When binding up solder, apply solder within range B.

8. MICROPROCESSOR

QU01 : TMP47C200BN

PIN NO.	PORT NAME	I/O	ACT	FUNCTION	PIN NO.	PORT NAME	I/O	ACT	FUNCTION		
1	R40	VOUP	O	L	VOLUME CONTROL (UP)	22	P20	LAX1	O	L	LED DISPLAY AUX1
2	R41	CL	O	H	SERIAL OUTPUT (CLOCK)	23	P21	LTUN	O	L	LED DISPLAY TUNER
3	R42	D1	O	H	SERIAL OUTPUT (DATA)	24	P22	LECD	O	L	LED DISPLAY CD
4	R43	CE	O	H	SERIAL OUTPUT (ENABLE)	25	P23	LPHO	O	L	LED DISPLAY PHONO
5	R50	VODW	O	L	VOLUME CONTROL (DOWN)	26	K00	1RS	I	L	ROTARY ENCODER BIT1
6	R51	EN1	I	-	MODEL SELECT #1	27	K01	2RS	I	L	ROTARY ENCODER BIT2
7	R52	EN2	I	-	MODEL SELECT #2	28	K02	UPK	I	L	SEQUENCE UP
8	R53	MUK	I	L	KEY INPUT MUTE	29	K03	DWK	I	L	SEQUENCE DOWN
9	R60	PRK	I	L	KEY INPUT PROCESSOR	30	TEST	TEST	-	-	NOT USED (GND.)
10	R61	T3K	I	L	KEY INPUT TAPE3	31	XIN	XIN	-	-	CLOCK 4.00MHz
11	R62	T2K	I	L	KEY INPUT TAPE2	32	XOUT	XOUT	-	-	
12	R63	T1K	I	L	KEY INPUT TAPE1	33	RESET	RES	I	L	RESET
13	R70	LDIS	O	L	LED DISPLAY OTHER	34	HOLD	PDW	I	L	POWER DOWN CHECK
14	R71	LMUT	O	L	LED DISPLAY MUTE	35	R80	RMC	I	L	REMOTE CONTROL (RC-5) INPUT
15	R72	LPRO	O	L	LED DISPLAY PROCESSOR	36	R81	FMUT	O	L	KMUT + MMUT
16	R73	LTP3	O	L	LED DISPLAY TAPE3	37	R82	KMUT	O	L	FUNCTION MUTING
17	P10	LTP2	O	L	LED DISPLAY TAPE2	38	R83	MMUT	O	L	MANUAL MUTING
18	P11	LTP1	O	L	LED DISPLAY TAPE1	39	R90	LPOW	O	L	LED DISPLAY POWER
19	P12	LSOU	O	L	LED DISPLAY SOURCE	40	R91	LSTB	O	L	LED DISPLAY STAND-BY
20	P13	LAX2	O	L	LED DISPLAY AUX2	41	R92	RELY	O	H	STAND-BY RELAY CONTROL
21	VSS	VSS	-	-	GND.	42	VDD	VDD	-	-	POWER SUPPLY +5.4V

9. ELECTRICAL PARTS LIST

ASSIGNMENT OF COMMON PARTS CODES.

RESISTOR
R*:** (1) GD05 --- 140, Carbon film fixed resistor, ±5%, 1/4W
R*:** (2) GD05 --- 160, Carbon film fixed resistor, ±5%, 1/6W
 ① — Resistance value

Examples
 ① Resistance value
 0.1Ω...001 10Ω...100 1kΩ...102 100kΩ...104
 0.5Ω...005 18Ω...180 2.7kΩ...272 680kΩ...684
 1Ω...010 100Ω...101 10kΩ...103 1MΩ...105
 6.8Ω...068 390Ω...391 22kΩ...223 4.7MΩ...475

(Note) Please distinguish 1/4W from 1/6W by the shape of parts used actually.

C*:** CERAMIC CAP.
 (1) DD1 --- 370, Ceramic condenser
 Disc type
 Temp. coeff. P350 ~ N1000, 50V
 ① ②
 Capacity value
 Tolerance

Examples
 ① Tolerance (Capacity deviation)
 ±0.25pF...0
 ±0.5pF...1
 ±5%...5
 * Tolerance of COMMON PARTS handled here are as follows:
 0.5pF ~ 5pF...±0.25pF
 6pF ~ 10pF...±0.5pF
 12pF ~ 560pF...±5%

② Capacity value
 0.5pF...005 3pF...030 100pF...101
 1pF...010 10pF...100 220pF...221
 1.5pF...015 47pF...470 560pF...561

C*:** CERAMIC CAP.
 (1) DK16 --- 300, High dielectric constant ceramic condenser
 Disc type
 Temp. chara. 2B4, 50V
 ①
 Capacity value

Example
 ② Capacity value
 100pF...101 1000pF...102 10000pF...103
 470pF...471 2200pF...222

C*:** ELECTROLY CAP. ($\frac{\pm}{\pm}$), FILM CAP. ($\frac{\pm}{\pm}$)
 (1) EA --- 10, Electrolytic condenser
 One-way lead type, Tolerance ±20%
 ① ②
 Dielectric strength
 Capacity value

Examples
 ① Capacity value
 0.1μF...104 4.7μF...475 100μF...107
 0.33μF...334 10μF...106 330μF...337
 1μF...105 22μF...226 1100μF...108
 2200μF...228
 ② Working voltage
 6.3V...006 25V...025
 10V...010 35V...035
 16V...016 50V...050

(2) DF15 --- 350, Plastic film condenser
 One-way type, Mylar ±5% 50V
 ①
 Capacity value

Examples
 ① Capacity value
 0.001μF (1000pF)...102 0.1μF...104
 0.0018μF...182 0.56μF...564
 0.01μF...103 1μF...105
 0.015μF...153

REF DESIG.	PART NO	DESCRIPTION
		PE01-TONE CONTROL CIRCUIT BOARD
		PE01-CAPACITORS
CE01	4822 121 43133	Film 0.039μF ±5%
CE02	4822 121 43133	Film 0.039μF ±5%
CE03	4822 121 51389	Film 5600pF ±5%
CE04	4822 121 51389	Film 5600pF ±5%
CE09	4822 124 22571	Elect 10μF 50V
CE10	4822 124 22571	Elect 10μF 50V
CW01	4822 122 32486	Ceramic 0.01μF +80% -20% [01B/01G/02B/02G]
CW02	4822 122 32486	Ceramic 0.01μF +80% -20% [01B/01G/02B/02G]
CW04	4822 122 32486	Ceramic 0.01μF +80% -20%
		PE01-RESISTORS
RE13	4822 101 30654	50KΩ Variable
RE14	4822 101 30654	50KΩ Variable
RW01	4822 050 22702	2.7KΩ ±5% 1/2W
RW02	4822 050 22702	2.7KΩ ±5% 1/2W
		PE01-SEMICONDUCTOR
DW01	4822 130 80839	Diode S5688G
		PE01-MISCELLANEOUS
QW02	4822 130 60693	Transistor 2SA817 (O, Y)
JW01	4822 267 31274	Jack, Peadphone [00B/01B/02B/05B/07B]
	4822 267 31365	Jack, Peadphone [01G/02G]
SS01	4822 276 30416	Push switch,
SW01	4822 276 30415	Push switch
		PG01-MASTER VOLUME CIRCUIT BOARD
CG01	4822 122 32486	Ceramic 0.01μF +80% -20%
RG01	4822 100 11906	Res. 50KΩ Variable
DG01	4822 130 33305	Diode 1SS176, etc.
LG01	4822 280 20469	Relay SVR24A
		PG51-BALANCE VOL. CIRCUIT BOARD
RG51	4822 101 30652	Variable Resistor 100KΩ
		PJ01-TAPE INPUT CIRCUIT BOARD
CJ01	4822 126 11069	Ceramic 150pF [01B/02B/01G/02G]
CJ16		
CJ17	4822 122 32486	Ceramic, Cap. 0.01μF +80% -20%
CJ32		
DJ01	4822 130 33305	Diode 1SS176, etc.
DJ04		
JJ01	4822 267 20348	Terminal, 4p RCA Pin
JJ04		
LJ01	4822 280 20469	Relay SVR24A
LJ04		
SJ01	4822 277 21352	Slide switch

REF DESIG.	PART NO	DESCRIPTION
		PT01-SOURCE SELECTOR CIRCUIT BOARD
ST01	4822 273 20368	Rotary switch
		PU01-μ-COM CIRCUIT BOARD
		PU01-CAPACITORS
CU01	4822 122 32486	Ceramic 0.01μF +80% -20%
CU02	4822 124 90352	Elect 10μF 16V
CU03	4822 122 32486	Ceramic 0.01μF +80% -20%
CU04	4822 122 32486	Ceramic 0.01μF +80% -20%
CU05	4822 122 32486	Ceramic 0.01μF +80% -20%
CU06	4822 124 41246	Elect 47μF 16V
CU07	4822 122 40617	Ceramic 0.1μF +80% -20%
CU08	4822 124 23128	Elect, big 0.047F 5.5V
CU09	4822 124 90352	Elect 10μF 16V
CU11		
CU21	4822 122 32486	Ceramic 0.01μF +80% -20%
		PU01-RESISTORS
RU01	4822 050 21021	100Ω ±5% 1/4W
RU31	4822 050 21021	100Ω ±5% 1/4W
RU35	4822 050 21021	100Ω ±5% 1/4W
		PU01-SEMICONDUCTORS
DU02	4822 130 32508	Diode RL103/DSF10C
DU03	4822 130 33305	Diode 1SS176, etc.
DU04		
DU14	4822 130 80326	L.E.D. LT3D8B (RED)
QU01	4822 209 31741	Microprocessor TMP47C200BN
QU02	4822 218 10343	Photo unit
QU03	4822 130 60107	Transistor 2SA1048 (Y, GR)
QU04	4822 130 60839	Transistor 2SC2458 (Y, GR)
QU05	4822 130 60107	Transistor 2SA1048 (Y, GR)
QU06	4822 130 60107	Transistor 2SA1048 (Y, GR)
QU07	4822 130 60107	Transistor 2SA1048 (Y, GR)
		PU01-MISCELLANEOUS
SU01	4822 276 20508	Push switch, Tact
SU05		
XU01	4822 242 72223	Ceramic Resonator, 4.00MHz
		PU51-VOLUME CONTROL CIRCUIT BOARD
CU51	4822 122 32486	Ceramic Cap. 0.01μF +80% -20%
CU52	4822 122 32486	Ceramic Cap. 0.01μF +80% -20%
CU53	4822 124 90352	Elect Cap 10μF 16V
CU54	4822 124 90352	Elect Cap. 10μF 16V
CU55	4822 122 32486	Ceramic Cap. 0.01μF +80% -20%
CU56	4822 122 32486	Ceramic Cap. 0.01μF +80% -20%
RU58	4822 116 60309	Resistor 2.2Ω ±5% 1/4W Fusible
DU51	4822 130 33305	Diode 1SS176, etc.
DU52	4822 130 33305	Diode 1SS176, etc.
DU53	4822 130 32508	Diode RL103/DSF10C
QU51	4822 209 73287	IC LB1630
QU52	4822 130 60839	Transistor 2SC2458 (Y, GR)
QU53	4822 130 60839	Transistor 2SC2458 (Y, GR)
QU54	4822 130 60839	Transistor 2SC2458 (Y, GR)
QU55	4822 130 60839	Transistor 2SC2458 (Y, GR)
LU51	4822 158 60605	Ferrite Core

REF DESIG.	PART NO	DESCRIPTION
		PV01-PHONO/SOURCE CIRCUIT BOARD
		PV01-CAPACITORS
CV01	4822 126 11069	Ceramic 150pF [01B/02B/01G/02G]
CV08		
CV09	4822 122 32486	Ceramic 0.01μF +80% -20%
CV18		
CV19	4822 124 22274	Elect 4.7μF 50V
CV91	4822 122 32486	Ceramic 0.01μF +80% -20%
C401	4822 122 32486	Ceramic 0.01μF +80% -20%
C402	4822 122 32486	Ceramic 0.01μF +80% -20%
C403	5322 121 54059	Film 220pF ±5% [00B/05B/07B]
	4822 126 11071	Ceramic 330pF ±10% 50V [01B/01G/02B/02G]
C404	5322 121 54059	Film 220pF ±5% [00B/05B/07B]
	4822 126 11071	Ceramic 330pF ±10% 50V [01B/01G/02B/02G]
C405	5322 121 42823	Film 2200pF ±5%
C406	5322 121 42823	Film 2200pF ±5%
C407	4822 124 22279	Elect 510μF 10V
C408	4822 124 22279	Elect 510μF 10V
C409	4822 124 22278	Elect 51μF 10V
C410	4822 124 22278	Elect 51μF 10V
C413	5322 121 42755	Film 0.012μF ±5%
C414	5322 121 42755	Film 0.012μF ±5%
C415	5322 121 42758	Film 1800pF ±5%
C416	5322 121 42758	Film 1800pF ±5%
C417	4822 124 90357	Elect 2.2μF 50V
C418	4822 124 90357	Elect 2.2μF 50V
C419	4822 121 70198	Film 3900pF ±5%
C420	4822 121 70198	Film 3900pF ±5%
C481	4822 124 90051	Elect 220μF 25V
C482	4822 124 90051	Elect 220μF 25V
		PV01-RESISTORS
R411	4822 050 24642	4.64KΩ ±1% 1/6W
R416		
R433	4822 050 24642	4.64KΩ ±1% 1/6W
R434	4822 050 24642	4.64KΩ ±1% 1/6W
R481	4822 113 90119	220Ω ±2% 1/4W (Fuse)
R482	4822 113 90119	220Ω ±2% 1/4W (Fuse)
		PV01-SEMICONDUCTORS
DV01	4822 130 33305	Diode 1SS176, etc.
DV09		
QV01	4822 130 60839	Transistor 2SC2458 (Y, GR)
QV08		
QV10	4822 130 60839	Transistor 2SC2458 (Y, GR)
QV11	4822 130 60839	Transistor 2SC2458 (Y, GR)
QV12	4822 209 73321	IC LC7822
Q401	4822 130 42839	F.E.T. 2SK369 (BL)
Q404		
Q405	4822 209 73064	IC NJM2068DD
		PV01-MISCELLANEOUS
JV01	4822 266 30274	Terminal, 2P RCA Pin
JV02	4822 267 20348	Terminal, 4P RCA Pin
JV03	4822 267 20348	Terminal, 4P RCA Pin
J401	4822 266 30232	Terminal, 2P RCA Pin
LV01	4822 280 20469	Relay SVR24A
LV08		
L401	4822 156 11019	Choke coil 320mH [01B/01G/02B/02G]
L402	4822 156 11019	Choke coil 320mH [01B/01G/02B/02G]
S401	4822 276 20468	Push switch

REF DESIG.	PART NO	DESCRIPTION
		PY01-LED INDICATOR CIRCUIT BOARD
DY01	4822 130 80326	L.E.D. LT3D8B (RED)
DY02	4822 130 80326	L.E.D. LT3D8B (RED)
		P701-MAIN AMP CIRCUIT BOARD
		P701-CAPACITORS
CN01	4822 124 22274	Elect 4.7 μ F 50V
CN02	4822 124 41539	Elect 47 μ F 16V
CN03	4822 124 41543	Elect 1 μ F 50V
CN04	4822 122 32486	Ceramic 0.01 μ F +80% -20%
CN05	4822 124 41539	Elect 47 μ F 16V
CN06	4822 124 41543	Elect 1 μ F 50V
CN07	4822 124 41539	Elect 47 μ F 16V
CN08	4822 122 32486	Ceramic 0.01 μ F +80% -20%
C701	5322 121 54078	Film 470pF \pm 5% [J00B/05B/07B]
	4822 126 11127	Ceramic 470pF \pm 10% 50V [J01B/01G/02B/02G]
C702	5322 121 54078	Film 470pF \pm 5% [J00B/05B/07B]
	4822 126 11127	Ceramic 470pF \pm 10% 50V [J01B/01G/02B/02G]
C703	4822 124 90361	Elect 22 μ F 25V
C704	4822 124 90361	Elect 22 μ F 25V
C705	4822 126 10513	Ceramic 47pF [J01B/01G/02B/02G]
C706	4822 126 10513	Ceramic 47pF [J01B/01G/02B/02G]
C707	4822 124 90354	Elect 100 μ F 16V
C708	4822 124 90354	Elect 100 μ F 16V
C709	4822 124 90361	Elect 22 μ F 25V
C710	4822 124 90361	Elect 22 μ F 25V
C711	4822 121 43127	Film 5pF \pm 10%
C712	4822 121 43127	Film 5pF \pm 10%
C713	4822 126 11126	Ceramic 5.6pF \pm 10%
C714	4822 126 11126	Ceramic 5.6pF \pm 10%
C715	4822 121 50562	Film 100pF \pm 5%
C716	4822 121 50562	Film 100pF \pm 5%
C717	4822 124 90361	Elect 22 μ F 25V
C718	4822 124 90361	Elect 22 μ F 25V
C719	4822 124 23071	Elect 470 μ F 63V
C720	4822 124 23071	Elect 470 μ F 63V
C721	4822 124 90354	Elect 100 μ F 16V
C722	4822 124 90354	Elect 100 μ F 16V
C723		
	4822 121 50548	Film 120pF \pm 5%
C726		
C727		
	4822 122 32486	Ceramic 0.01 μ F +80% -20% [J01B/01G/02B/02G]
C730		
C781	4822 124 23068	Elect 220 μ F 63V
C782	4822 124 23071	Elect 470 μ F 63V
C783	4822 122 30043	Ceramic 0.01 μ F +80% -20%
		P701-RESISTORS
▲ RN13	4822 113 90119	220 Ω \pm 2% 1/4W (Fuse)
RN17	4822 050 23303	33K Ω \pm 5% 1/4W
RN19	4822 050 21503	56K Ω \pm 5% 1/2W
▲ R707	4822 116 81748	330 Ω \pm 2% 1/4W (Fuse)
▲ R708	4822 116 81748	330 Ω \pm 2% 1/4W (Fuse)
R715	4822 050 23303	33K Ω \pm 5% 1/4W
R716	4822 050 23303	33K Ω \pm 5% 1/4W
▲ R725	4822 117 10031	4.7K Ω \pm 5% 2W (Metal)
▲ R726	4822 117 10002	2.2K Ω \pm 5% 1/2W
R737	4822 100 20681	2.2K Ω , Trimming
R738	4822 100 20681	2.2K Ω , Trimming
R741	4822 100 11372	47K Ω , Trimming
R742	4822 100 11372	47K Ω , Trimming
▲ R743	4822 052 10101	100 Ω \pm 5% 1/6W
▲ R744	4822 052 10101	100 Ω \pm 5% 1/6W
▲ R745	4822 052 10479	47 Ω \pm 5% 1/4W
▲ R746	4822 052 10479	47 Ω \pm 5% 1/4W
R747	4822 052 10101	100 Ω \pm 5% 1/6W
R748	4822 052 10101	100 Ω \pm 5% 1/6W
R749	4822 052 10101	100 Ω \pm 5% 1/6W
R750	4822 052 10101	100 Ω \pm 5% 1/6W

REF DESIG.	PART NO	DESCRIPTION
▲ R751	4822 052 10102	1K Ω \pm 5% 1/6W
▲ R752	4822 052 10102	1K Ω \pm 5% 1/6W
R753	4822 052 10109	10 Ω \pm 5% 1/6W
R754	4822 052 10109	10 Ω \pm 5% 1/6W
R755	4822 052 10109	10 Ω \pm 5% 1/6W
R756	4822 052 10109	10 Ω \pm 5% 1/6W
▲ R757	4822 116 60494	330 Ω \pm 5% 2W (Metal)
▲ R758	4822 116 60494	330 Ω \pm 5% 2W (Metal)
R759		
	4822 116 83963	2.2 Ω \pm 5% 1/4W
R762		
▲ R763	4822 113 80612	0.18 Ω x2 \pm 10% 5W
▲ R764	4822 113 80612	0.18 Ω x2 \pm 10% 5W
R767	4822 116 83929	220 Ω \pm 5% 1/4W
R768	4822 116 83929	220 Ω \pm 5% 1/4W
R769	4822 116 83353	10 Ω \pm 5% 3W (Metal)
R770	4822 116 83353	10 Ω \pm 5% 3W (Metal)
R771	4822 116 60494	330 Ω \pm 5% 2W (Metal)
R772	4822 116 60494	330 Ω \pm 5% 2W (Metal)
▲ R781	4822 050 21008	1 Ω \pm 5% 1/4W
▲ R782	4822 050 21008	1 Ω \pm 5% 1/4W
		P701-SEMICONDUCTORS
DN01	4822 130 80837	Diode HSS81TD
DN02	4822 130 80837	Diode HSS81TD
▲ DN03	4822 130 80839	Diode S5688G
DN04	4822 130 33305	Diode 1SS176, etc.
DN05	4822 130 33305	Diode 1SS176, etc.
DN06	4822 130 33305	Diode 1SS176, etc.
D701	4822 130 80273	Zener RD8.2JB2/MTZJ8.2C
D702	4822 130 80322	Zener RD15JB3/MTZJ16A
D703		
	4822 130 33305	Diode 1SS176, etc.
D706		
D707		
	4822 130 80837	Diode HSS81TD
D712		
D713	4822 130 80932	Zener RD6.2JB2/MTZJ6.2B
D714	4822 130 80932	Zener RD6.2JB2/MTZJ6.2B
D715	4822 130 80837	Diode HSS81TD
D716	4822 130 80837	Diode HSS81TD
D717	4822 130 80932	Zener RD6.2JB2/MTZJ6.2B
D718	4822 130 80932	Zener RD6.2JB2/MTZJ6.2B
▲ D719		
	4822 130 80839	Diode S5688G
▲ D726		
▲ QN01	4822 209 83312	IC TA7317P:
QN02	4822 130 43233	Transistor 2SC2240 (GR,BL)
QN03	4822 130 43233	Transistor 2SC2240 (GR,BL)
QN04	4822 130 42951	Transistor 2SA970 (GR,BL)
▲ Q701	4822 209 83732	IC AN7062
Q703	4822 130 42999	Transistor 2SA1145 (O,Y)
Q704	4822 130 42999	Transistor 2SA1145 (O,Y)
Q705	4822 130 43283	Transistor 2SC2705 (O,Y)
Q706	4822 130 43283	Transistor 2SC2705 (O,Y)
Q707	4822 130 90347	Photo unit PC-817
Q708	4822 130 90347	Photo unit PC-817
▲ Q709	4822 130 60526	Transistor 2SD1508
▲ Q710	4822 130 60526	Transistor 2SD1508
▲ Q711	4822 130 43225	Transistor 2SC2229 (O,Y)
▲ Q712	4822 130 43225	Transistor 2SC2229 (O,Y)
▲ Q713	4822 130 63145	Transistor 2SA949 (O,Y)
▲ Q714	4822 130 63145	Transistor 2SA949 (O,Y)
▲ Q715	4822 130 63149	Transistor 2SC3298 (O,Y)
▲ Q716	4822 130 63149	Transistor 2SC3298 (O,Y)
▲ Q717	4822 130 63147	Transistor 2SA1306 (O,Y)
▲ Q718	4822 130 63147	Transistor 2SA1306 (O,Y)
▲ Q719	4822 130 63148	Transistor 2SC3281 (R,O)
▲ Q720	4822 130 63148	Transistor 2SC3281 (R,O)
▲ Q721	4822 130 63146	Transistor 2SA1302 (R,O)
▲ Q722	4822 130 63146	Transistor 2SA1302 (R,O)
		P701-MISCELLANEOUS
J701	4822 290 61072	Terminal,SPK [J00B/01B/01G/05B/07B]
J702	4822 290 60841	Terminal,SPK [J02B/02G]
	4822 290 61071	Terminal,SPK [J00B/01B/01G/05B/07B]
	4822 290 60839	Terminal,SPK [J02B/02G]

REF DESIG.	PART NO	DESCRIPTION
LN01	4822 280 70354	Relay 5A 24V
LN02	4822 280 70354	Relay 5A 24V
LN03	4822 280 20196	Relay 24V
L701	4822 157 70022	Air Coil
L702	4822 157 70022	Air Coil
P801-MAIN POWER SUPPLY CIRCIT BOARD		
▲ C801	4822 124 23067	Elect Cap. 18000 μ F /63Vx2
C802	4822 122 30043	Ceramic 0.01 μ F +80% -20% [O1B/O1G/O2B/O2G]
C803	4822 122 30043	Ceramic 0.01 μ F +80% -20% [O1B/O1G/O2B/O2G]
▲ G801	4822 121 20263	Spark killer RFD2B474K
▲ D801	4822 130 33132	Diode D5FB20
▲ D802	4822 130 33305	Diode 1SS176,etc.
▲ L801	4822 280 20403	Relay MC24D20
P851-SMALL POWER SUPPLY CIRCIT BOARD		
P851-CAPACITORS		
C851	4822 122 32486	Ceramic 0.01 μ F +80% -20%
C852	4822 122 32486	Ceramic 0.01 μ F +80% -20%
C853	4822 124 41543	Elect 1 μ F 50V
C854	4822 124 41542	Elect 470 μ F 50V
C855	4822 124 23918	Elect 1000 μ F 50V
C856		
?	4822 124 41543	Elect 1 μ F 50V
C861		
C862	4822 124 90367	Elect 2200 μ F 25V
C863	4822 124 41543	Elect 1 μ F 50V
P851-SEMICONDUCTORS		
▲ D851		
?	4822 130 80839	Diode S5688G
▲ D860		
D861	4822 130 32508	Diode RL103E/DSF10C
▲ Q851	4822 209 83823	IC NJM78M24FA
▲ Q852	4822 209 62423	IC NJM78M06FA
▲ Q853	4822 209 80675	IC NJM78M18FA
▲ Q854	4822 209 31788	IC NJM79M18FA
P851-MISCELLANEOUS		
▲ F851	4822 070 31002	Fuse, 1A 250V
▲ F852	4822 070 31002	Fuse, 1A 250V
P901-TRANSFORMER/FUSE CIRCIT BOARD		
▲ F901	4822 070 33152	Fuse, 3.15A 250V [O2G/O2B/O5B/O7B/O0B]
▲ F902	4822 253 30387	Fuse, 4A 250V
▲ F903	4822 253 30387	Fuse, 4A 250V
P951-POWER SW CIRCT BOARD		
▲ G951	4822 122 33276	Ceramic Cap. 0.01 μ F \pm 20%
▲ S951	4822 276 12647	Push switch, Power

NOTE ON SAFETY :

Symbol ▲ Fire or electrical shock hazard. Only original parts should be used to replace any part marked with symbol ▲ . Any other component substitution (other than original type), may increase risk of fire or electrical shock hazard.