

**SERVICE  
MANUAL**

**marantz®**

**model PM-84II**

*Stereo Amplifier*

## MARANTZ DESIGN AND SERVICE

Using superior design and selected high grade components, MARANTZ company has created the ultimate in stereo sound. Only **original MARANTZ parts** can insure that your MARANTZ product will continue to perform to the specifications for which it is famous.

Parts for your MARANTZ equipment are generally available to our National Marantz Subsidiary or Agent.

### ORDERING PARTS:

Parts can be ordered either by mail or by telex. In both cases, MARANTZ part number has to be specified. If you order by mail, fulfil MARANTZ order forms.

MARANTZ TRADING S.A.  
326 Avenue Louise Bte 32  
1050 Brussels  
Belgium

The following information must be supplied to eliminate delays in processing your order:

1. Complete address
2. Complete part numbers and quantities required
3. Description of parts
4. Model number for which part is required
5. Way of shipment
6. Signature: any order form or telex must be signed otherwise such part order will be considered as null and void.

### PARTS ORDERING:

Parts may be ordered from the following addresses:

#### EUROPE

##### MARANTZ EUROPE

326 Avenue Louise Bte 32  
1050 Brussels  
Belgium

##### MARANTZ TRADING S.A.

326 Avenue Louise Bte 32  
1050 Brussels  
Belgium

##### AUSTRIA

HORNYPHON  
Vertriebsgesellschaft GmbH  
Wienerbergstrasse 1  
A 1101 Wien  
Austria

##### BELGIUM

SVD DIVISION MARANTZ  
Industrialaan 1  
B 1720 Groot-Bijgaarden  
Belgium

##### DENMARK

MARANTZ  
Division of Philips Service A/S  
Prags Boulevard 80  
Postbox 1919  
DK 2300 København S  
Denmark

##### FINLAND

MARANTZ  
Division of Oy Philips Ab  
Kaivokatu 8  
00100 Helsinki  
Finland

##### FRANCE

MARANTZ FRANCE  
4 Rue Bernard Palissy  
F 92600 Asnières  
France

##### SWITZERLAND

DYNAVOX ELECTRONICS  
Route de Villars 105  
CH 1701 Fribourg  
Switzerland

##### SPAIN

PHONO S.A.  
Ignacio Iglesias 10  
Barcelona (Badalona)  
Spain

##### THE NETHERLANDS

MARANTZ  
De Ilimiet 3  
NL 4131 NR Vianen  
The Netherlands

##### GERMANY

MARANTZ GERMANY GmbH  
Max-Planck-Strasse 22  
D 6072 Dreieich 1  
Germany

##### GREAT BRITAIN

MARANTZ AUDIO U.K. Ltd  
Unit 15/16  
Saxon Way Industrial Estate  
Moor Lane  
Harmondsworth UB7 0LW  
Great Britain

##### TURKEY

DOGRUOL LTD  
I.M.C  
6 Blok No 6310  
Unkapani  
Istanbul  
Turkey

##### NORWAY

MARANTZ  
Division of Philips A/S  
Sandstuveien 40  
Oslo 6  
Norway

##### ITALY

MARANTZ ITALIANA S. P. A.  
Via Chiese, 74  
20126 Milano  
Italy

##### SWEDEN

MARANTZ  
Division of Philips Försäljning AB  
Tegeluddsvägen 1  
S115 84 Stockholm  
Sweden

##### YUGOSLAVIA

VELEBIT OOUR  
Inoz Zastupstva  
Babukiceva 3A  
P.O. Box 1044  
41000 Zagreb  
Yugoslavia

##### GREECE

ADAMCO S.A.  
P.O. Box 21025  
Ippocrates Street 188  
Athens 11410  
Greece

##### AUSTRALIA

MARANTZ AUSTRALIA PTY., LTD.  
19 Chard Road  
Brookvale, NSW 2100  
Australia  
Telex: 24121

All of the above locations are fully equipped to take care of your total service needs. Because various countries have differing configuration requirements, it is necessary that you contact the service facility in your particular country. In the event that there is no service location listed for your country, please, contact the nearest facility for the necessary assistance.

In case of difficulties, do not hesitate to contact the Technical Department at abovementioned address.

**marantz**®

## TABLE OF CONTENTS

SECTION	PAGE
INTRODUCTION .....	1
1. P.W. BOARDS .....	1
2. TEST EQUIPMENT REQUIRED FOR SERVICING .....	2
3. ADJUSTMENT PROCEDURE .....	2
4. VOLTAGE CONVERSION .....	3
5. BLOCK DIAGRAM .....	4
6. SCHEMATIC DIAGRAM AND COMPONENT LOCATIONS .....	5
6.1 Tape Monitor Switch Assembly (PT01) Schematic Diagram and Component Locations .....	5
6.2 Speaker Relay/Terminal Assembly (PW01) Schematic Diagram and Component Locations .....	5
6.3 Voltage Amp Assembly (P701) Schematic Diagram and Component Locations .....	6
6.4 Power Amp Bias TR Assembly (P711) Schematic Diagram and Component Locations .....	6
6.5 Power Amp Bias TR Assembly (P721) Schematic Diagram and Component Locations .....	6
6.6 Tape IN/OUT Assembly (PJ01) Schematic Diagram and Component Locations .....	8
6.7 Tape Monitor Assembly (PY51) Schematic Diagram and Component Locations .....	8
6.8 Phono/MC, MM Input Assembly (PV01) Schematic Diagram and Component Locations .....	9
6.9 Power MOS FET Assembly (PL01) Schematic Diagram and Component Locations .....	11
6.10 Main Power Diode Assembly (P801) Schematic Diagram and Component Locations .....	12
6.11 Main Power Supply Assembly (P851) Schematic Diagram and Component Locations .....	13
6.12 Subsonic, Mono, CD, Direct Assembly (PS01) Schematic Diagram and Component Locations .....	15
6.13 Flat/Tone Amp Assembly (PE01) Schematic Diagram and Component Locations .....	16
6.14 Tone Volume (R) Assembly (PF01) Schematic Diagram and Component Locations .....	16
6.15 Tone Volume (L) Assembly (PF51) Schematic Diagram and Component Locations .....	16
6.16 Headphone, Speaker, Switch Assembly (PW51) Schematic Diagram and Component Locations .....	18
6.17 Master Volume Assembly (PG01) Schematic Diagram and Component Locations .....	18
6.18 Function LED Assembly (PY01) Schematic Diagram and Component Locations .....	18
7. EXPLODED VIEW AND PARTS LIST .....	19
8. ELECTRICAL PARTS LIST .....	25
9. TECHNICAL SPECIFICATIONS .....	31
10. SCHEMATIC DIAGRAM .....	32

### How to use this service manual

- The "Common parts" which Marantz Japan, Inc. has established are eliminated from this service manual.
- These "Common parts" are applied to all models in the service manuals arranged and issued by MJI.
- To indicate clearly the common parts in the schematic diagram, a line is drawn above or under the Ref. Desig. No. of applicable parts.
- "Common parts" can be supplied from the Marantz service center as ever.  
In case of ordering, please establish the parts number of 10 figures following the procedure mentioned in this service manual "How to establish the parts number for common parts".

**(NOTE)**

When you order parts to the Marantz parts center, please take notice of the following points.

- 1) Please correctly write the parts number of 10 figures following the rule.
- 2) Since ordering parts by the Ref. Desig. No. or ratings indicated in the schematic diagram does not satisfy the above conditions, the Marantz parts supply system does not work properly.  
As this case is apt to cause a trouble, please pay attention to it.

M 7014 TB

## MODEL PM-84II STEREO AMPLIFIER

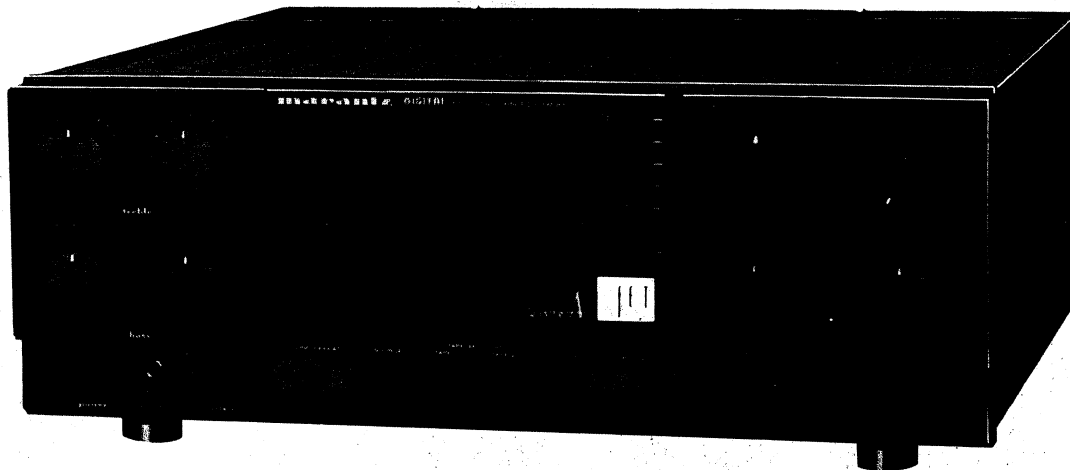

### INTRODUCTION

This service manual was prepared for use by Authorized Warranty Stations and contains service information for the Marantz Model PM-84II Stereo Amplifier.

Servicing information and voltage data included in this manual are intended for use by knowledgeable and experienced personnel only. All instructions should be read carefully. No attempt should be made to proceed without a good understanding of circuitry operation.

The parts list furnishes complete ordering information. Most replacement parts should be ordered from the Marantz Company. However, a simple description is included for parts which can be obtained locally.

### 1. P.W. BOARDS

As can be seen from the circuit diagram the chassis of Model PM-84II consists of the following units. Each unit mounted on a printed circuit board is described within the square enclosed by a bold dotted line on the circuit diagram.

1. Flat/Tone Amp . . . . . mounted on P.W. Board PE01
2. Tone Volume (R) . . . . . mounted on P.W. Board PF01
3. Tone Volume (L) . . . . . mounted on P.W. Board PF51
4. Master Volume . . . . . mounted on P.W. Board PG01
5. Tape IN/OUT . . . . . mounted on P.W. Board PJ01
6. Power MOS FET . . . . . mounted on P.W. Board PL01
7. Subsonic, Mono, CD,  
Direct . . . . . mounted on P.W. Board PS01
8. Tape Monitor Switch . . . . . mounted on P.W. Board PT01
9. Phono/MC, MM Input . . . . . mounted on P.W. Board PV01
10. Speaker Relay/  
Terminal . . . . . mounted on P.W. Board PW01
11. Headphone,  
Speaker Switch . . . . . mounted on P.W. Board PW51
12. Function LED . . . . . mounted on P.W. Board PY01
13. Tape Monitor . . . . . mounted on P.W. Board PY51
14. Voltage Amp . . . . . mounted on P.W. Board P701
15. Power Amp Bias TR . . . . . mounted on P.W. Board P711
16. Power Amp Bias TR . . . . . mounted on P.W. Board P721
17. Main Power Diode . . . . . mounted on P.W. Board P801
18. Main Power Supply . . . . . mounted on P.W. Board P851

1  
11

M7015

## 2. TEST EQUIPMENT REQUIRED FOR SERVICING

This table lists the test equipment required for servicing the Model PM-84II Stereo Amplifier.

Item	Use
Distortion Analyzer	Distortion measurements
Audio Oscillator	Sinewave and squarewave signal source
AC VTVM	Voltage measurements (AC)
Oscilloscope	Waveform analysis and trouble shooting and ASO alignment
Circuit Tester	Trouble shooting
DC VTVM	Voltage measurements (DC)
AC Wattmeter	Monitors primary power to amplifier
Line Voltmeter	Monitors potential of primary power to amplifier
Variable Autotransformer (0 ~ 140V AC, 10A)	Adjust level of primary power to amplifier
Shorting Plug	Shorts amplifier input to eliminate noise pickup

## 3. ADJUSTMENT PROCEDURE

### Idling Adjustment

1. With no signal and no load, short-circuit TP-5 and TP-6 on the P.W. Board (P701).
2. Connect the digital voltmeter at the DC range to the center of the RL09 and RL13 (RL10 and RL14) cement resistors on the P.W. Board (PL01) and adjust R727 (R728) on the P.W. Board (P701) for a voltage of 40 mV.
3. Open TP-5 and TP-6 and adjust R725 (R726) on the P.W. Board (P701) so that the digital voltmeter reads 112 mV.
4. Next short-circuit TP-6 and TP-7 and adjust R723 (R724) on the P.W. Board (P701) so that the digital voltmeter reads 250 mV.
5. Perform the same adjustment for the right channel using the parts indicated in parentheses.

M 2016

2 T<sub>h</sub>

#### 4. VOLTAGE CONVERSION

• EUROPEAN MODEL ONLY

To convert the unit to a different power source voltage, change the position as illustrated in the drawing below.

**CAUTION**  
DISCONNECT POWER SUPPLY CORD FROM AC  
OUTLET BEFORE CONVERTING VOLTAGE.

Voltage Conversion Chart

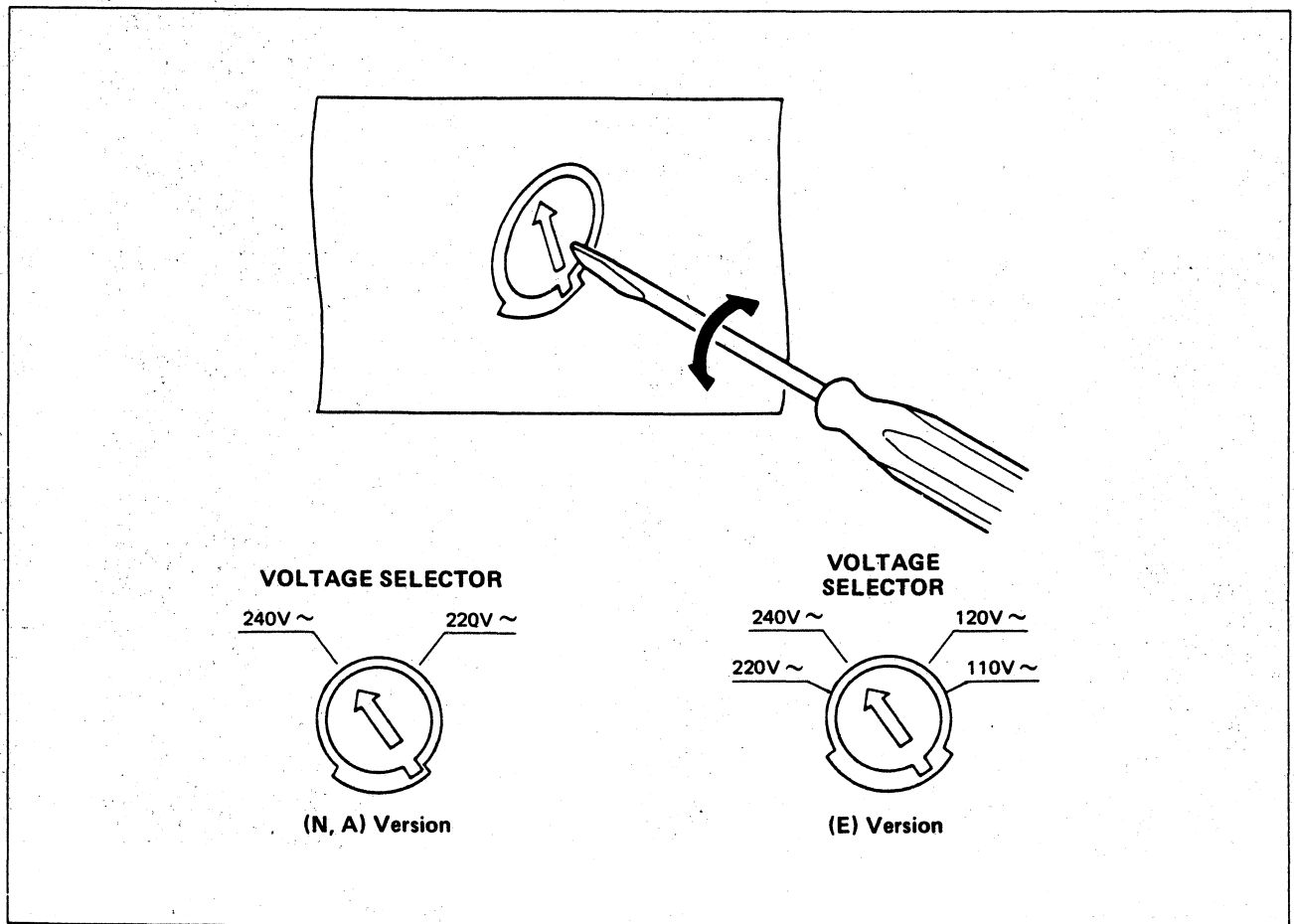

**Note on safety:** Symbol  $\triangle$  Fire or electrical shock hazard. Only original parts should be used to replace any part marked with symbol  $\triangle$ . Any other component substitution (other than original type), may increase risk of fire or electrical shock hazard.

# 5. BLOCK DIAGRAM

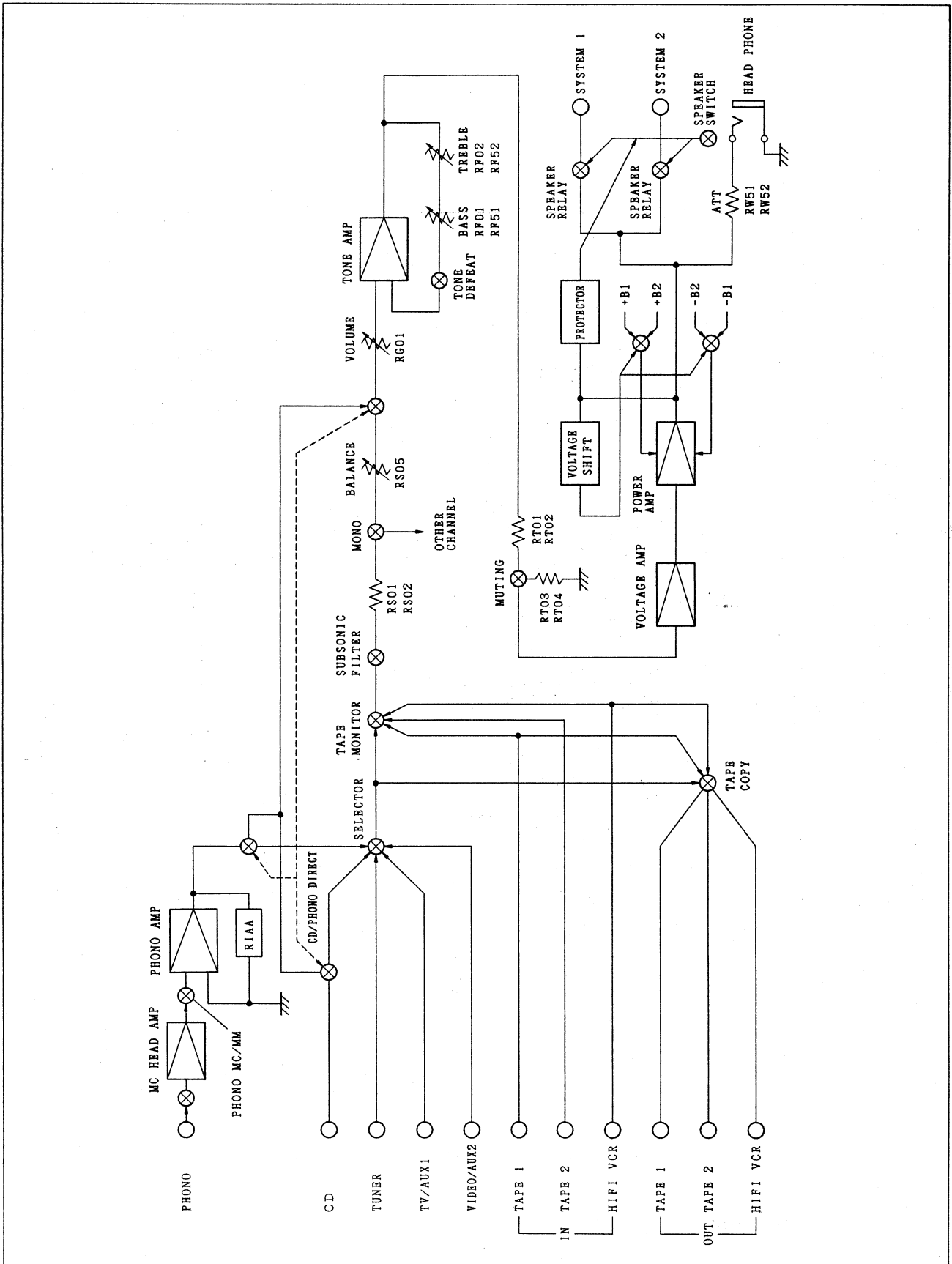

M7018

4 16

## 6. SCHEMATIC DIAGRAM AND COMPONENT LOCATIONS

### 6.1 Tape Monitor Switch Assembly (PT01) Schematic Diagram and Component Locations

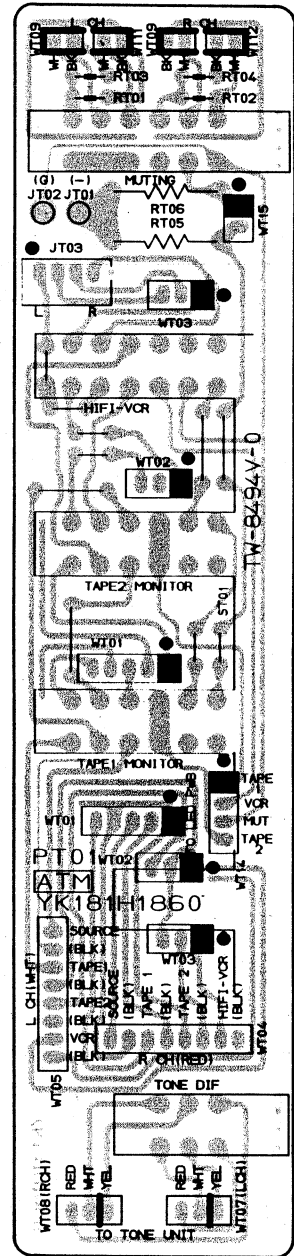
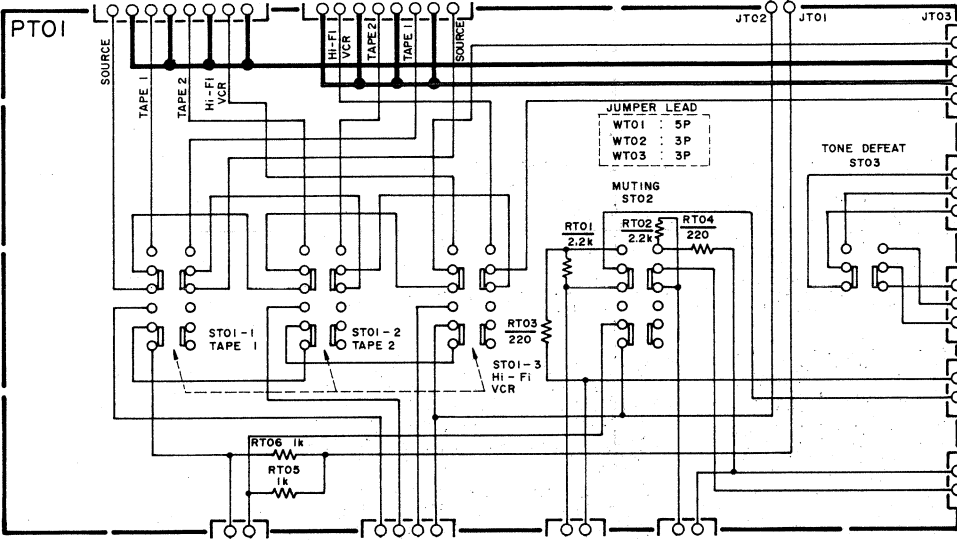

### 6.2 Speaker Relay/Terminal Assembly (PW01) Schematic Diagram and Component Locations

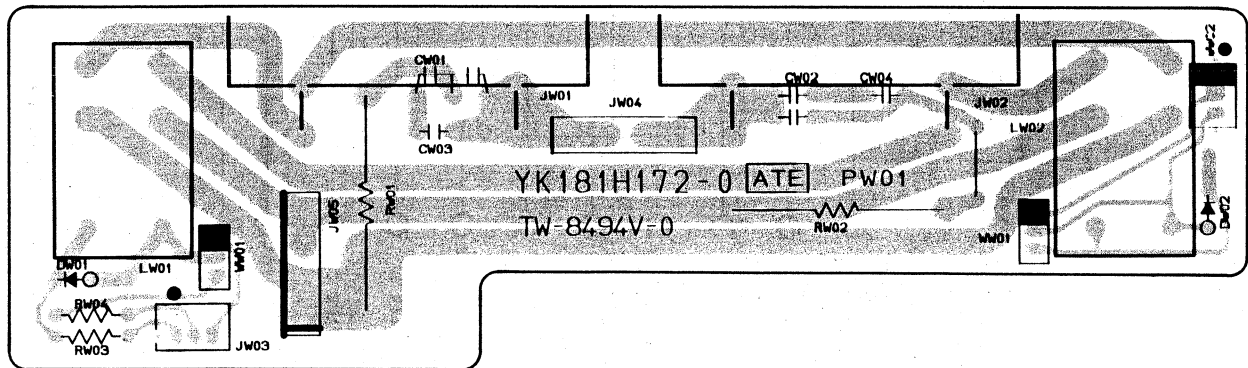
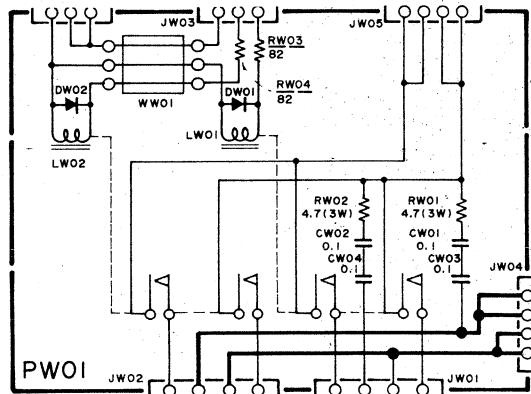



6.3 Voltage Amp Assembly (P701) Schematic Diagram and Component Locations

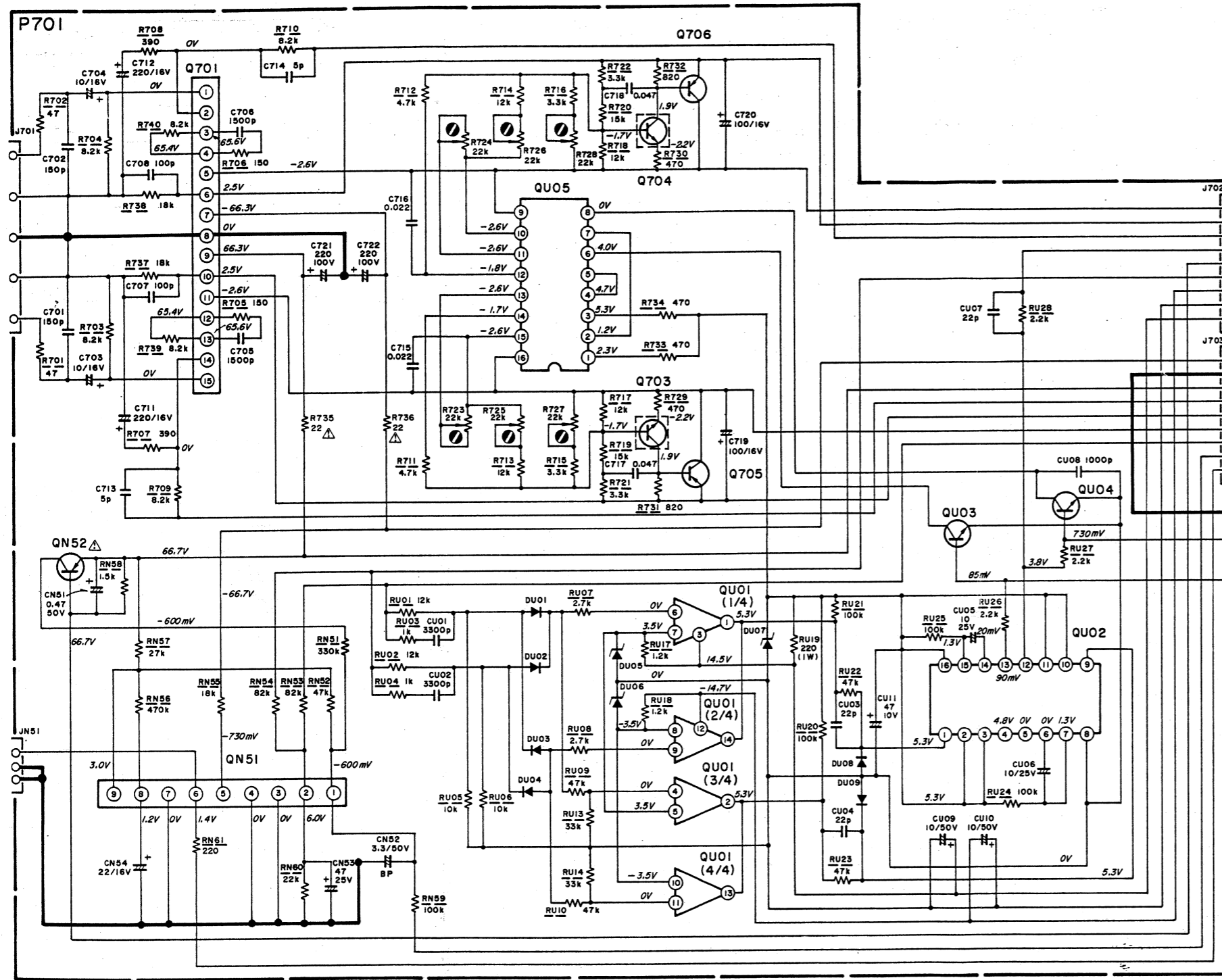

6.4 Power Amp Bias TR Assembly (P711) Schematic Diagram and Component Locations



6.5 Power Amp Bias TR Assembly (P721) Schematic Diagram and Component Locations

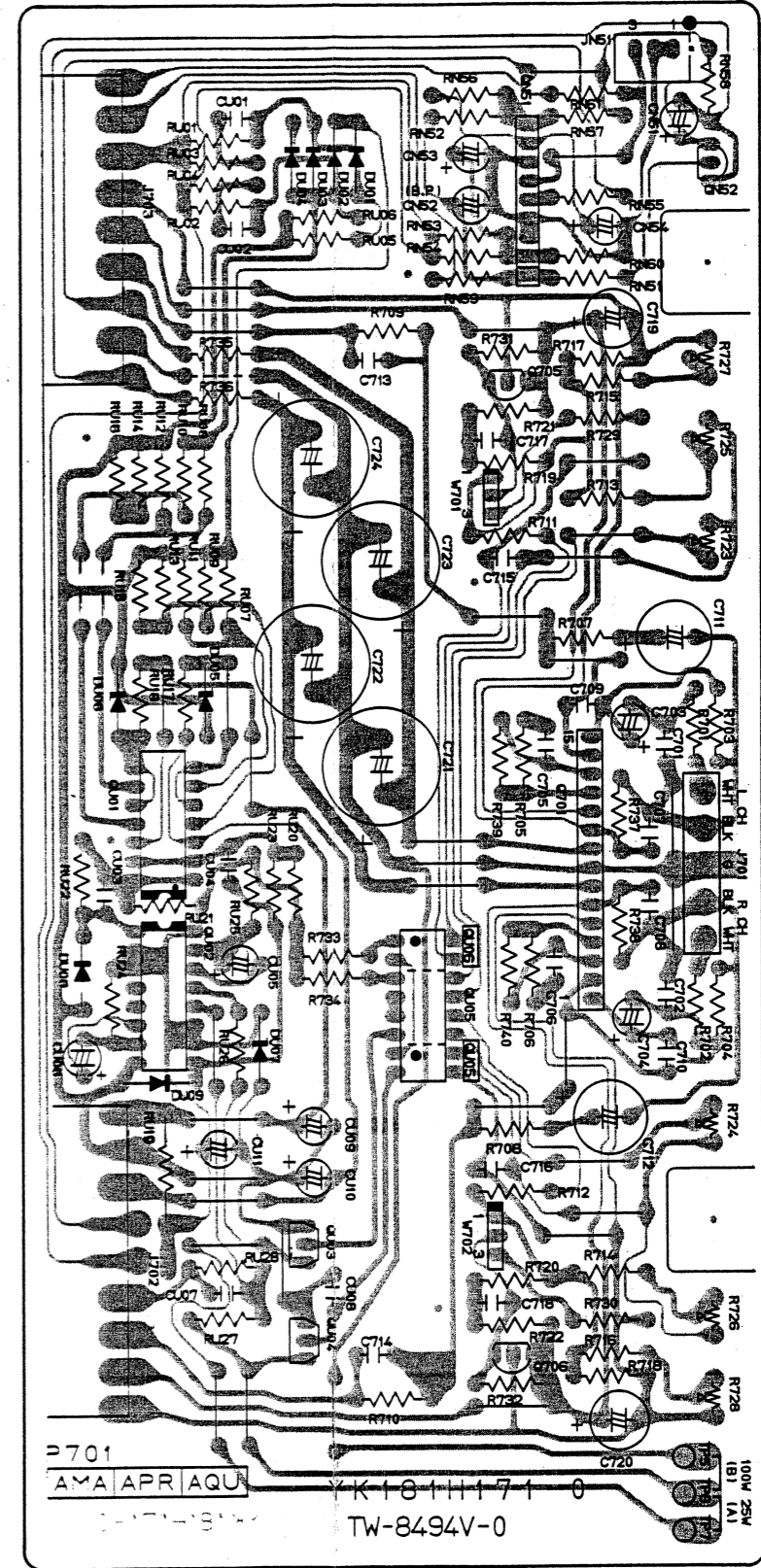
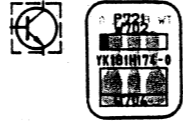

M7020

6 TB

7 TB

**6.6 Tape IN/OUT Assembly (PJ01)**  
Schematic Diagram and Component Locations

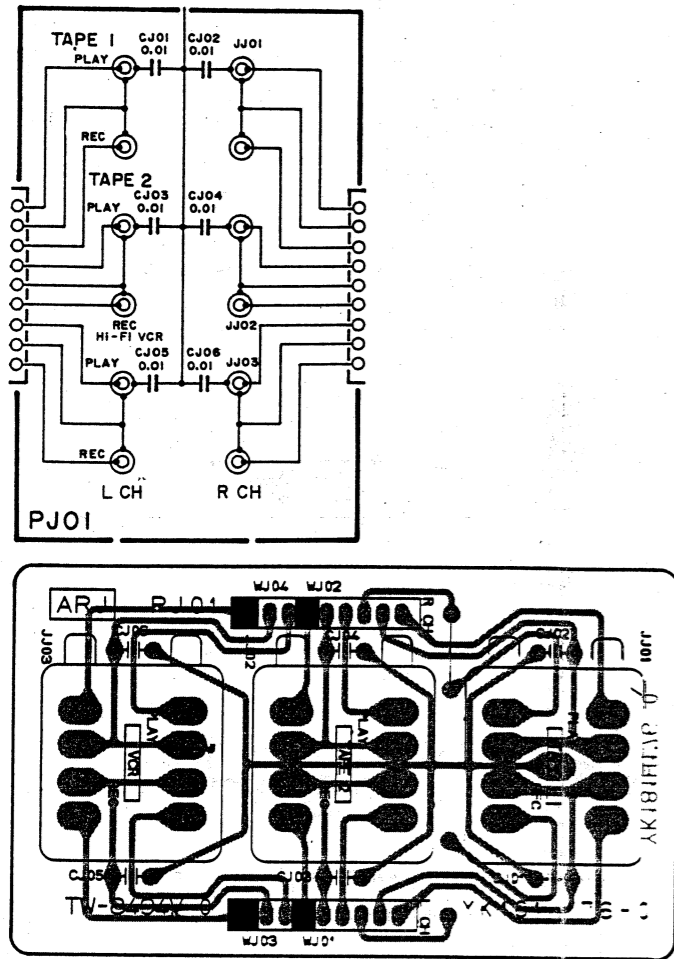

**6.7 Tape Monitor Assembly (PY51)**  
Schematic Diagram and Component Locations

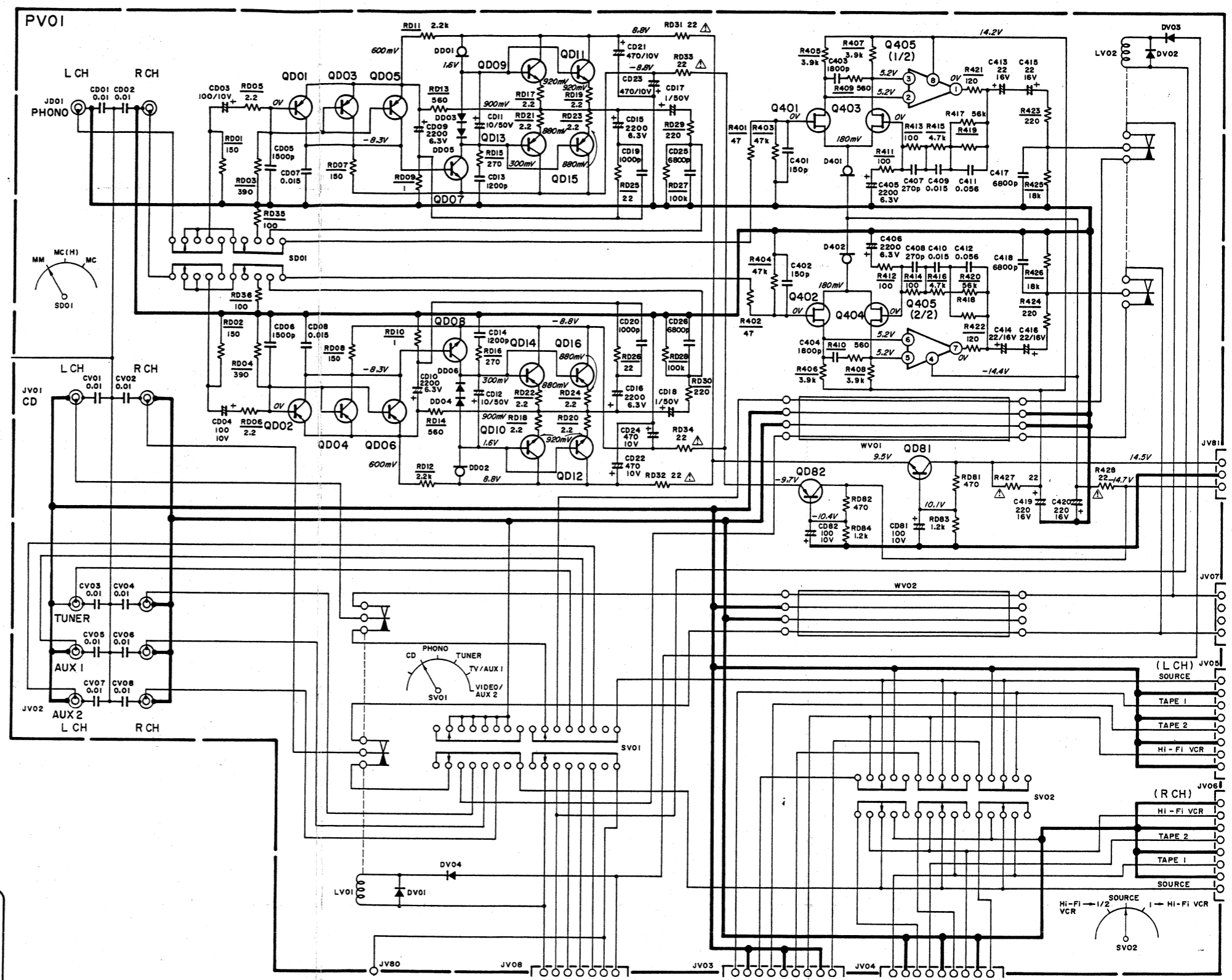
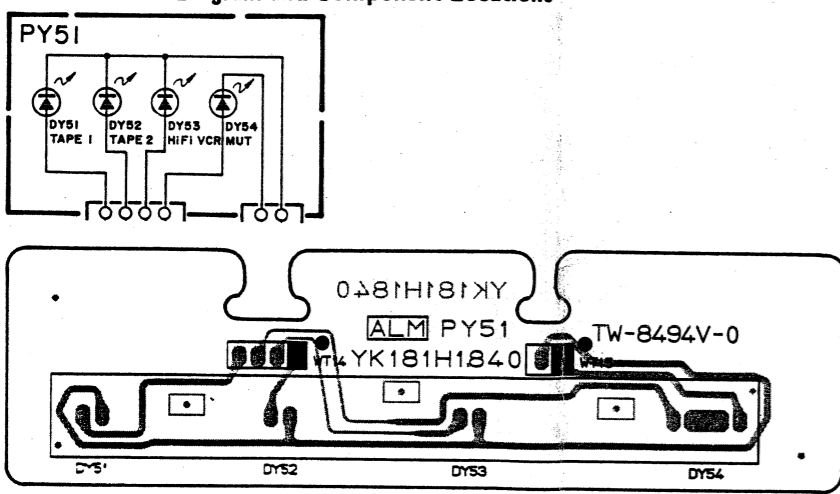

8 1/4

9 1/2

M7021

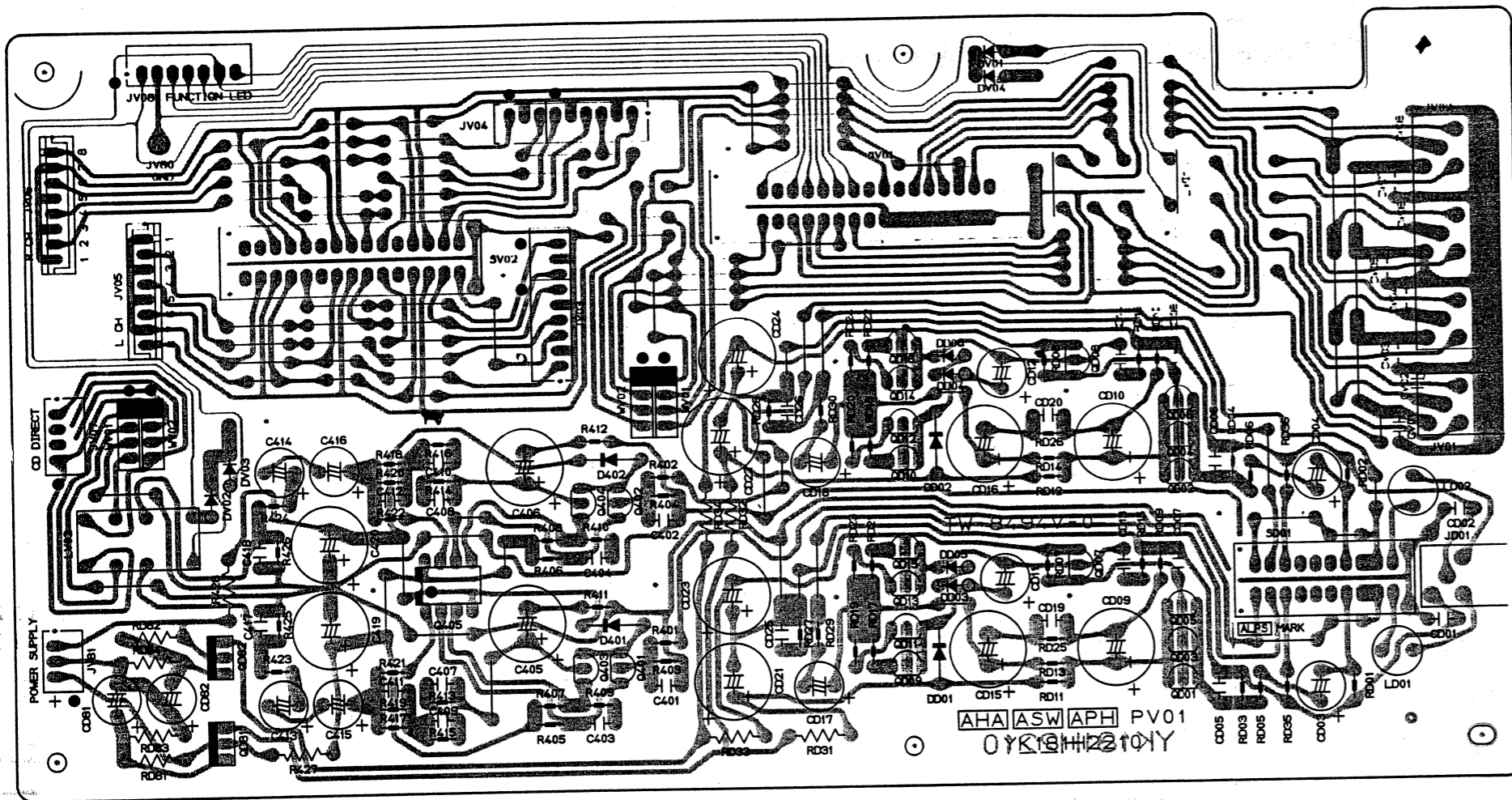

6.9 Power MOS FET Assembly (PL01)  
Schematic Diagram and Component Locations

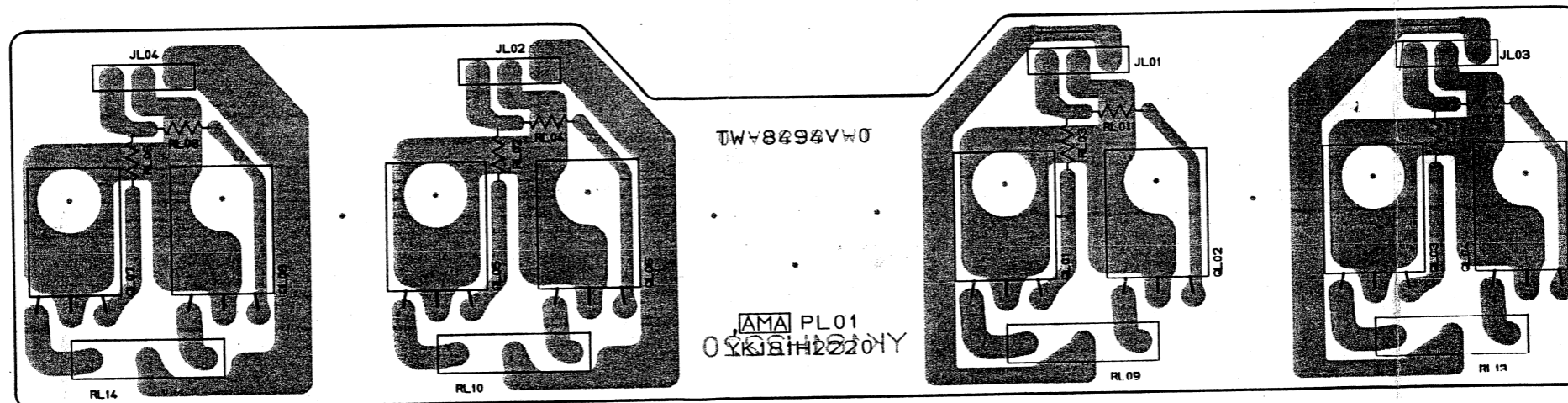
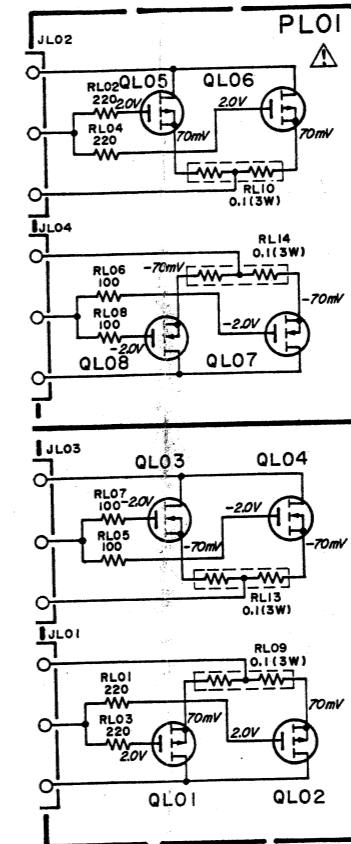

6.11 Main Power Supply Assembly (P851) Schematic Diagram and Component Locations

6.10 Main Power Diode Assembly (P801) Schematic Diagram and Component Locations

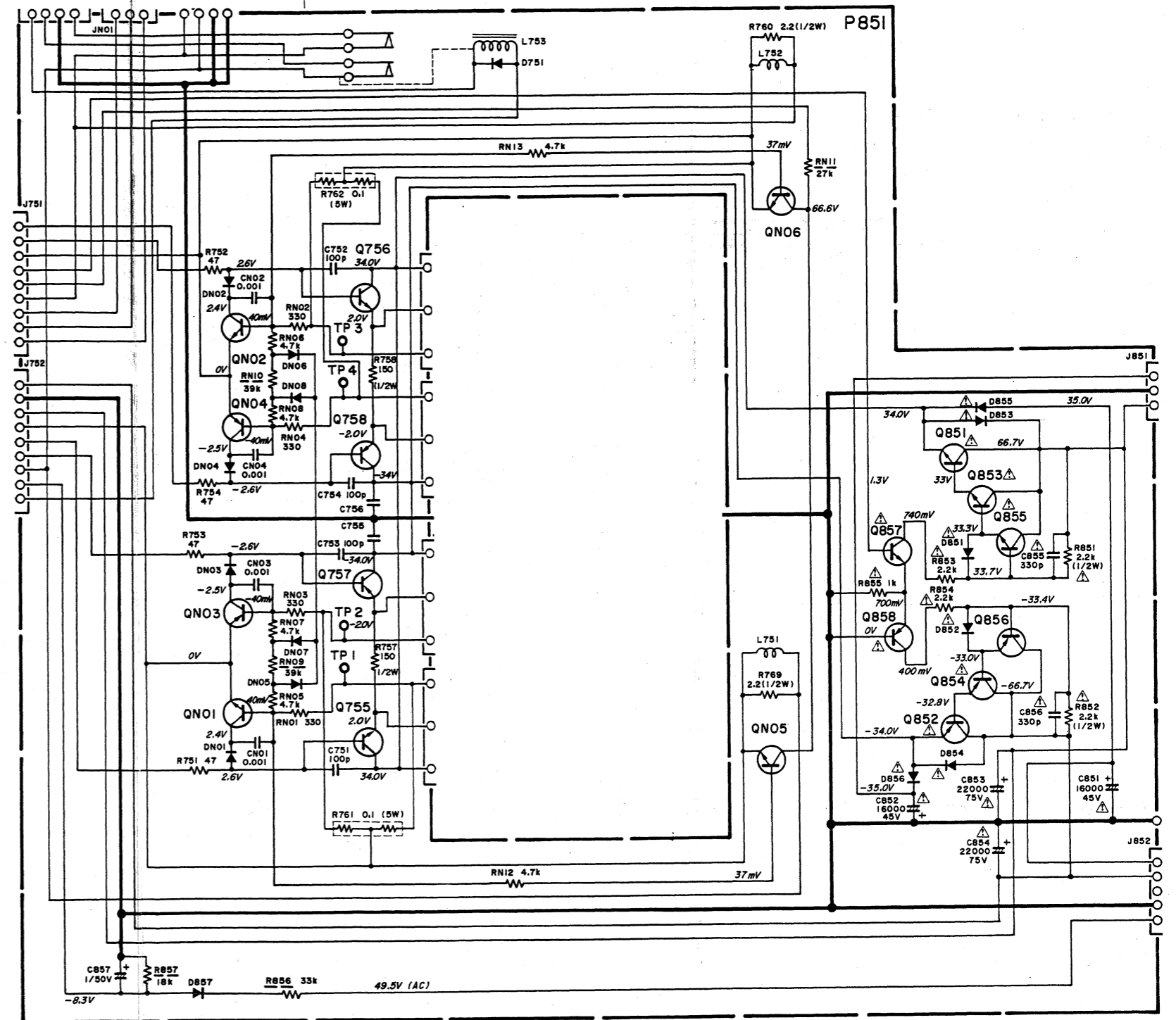
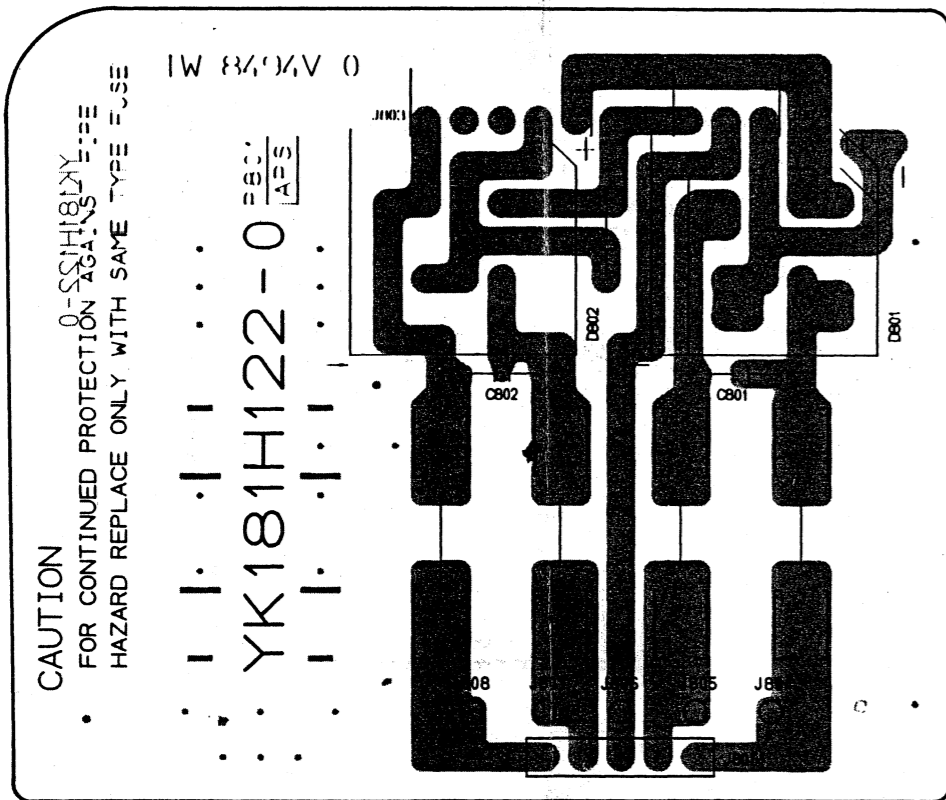
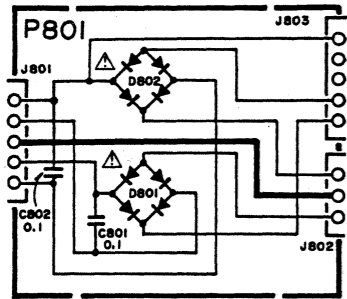

15

15

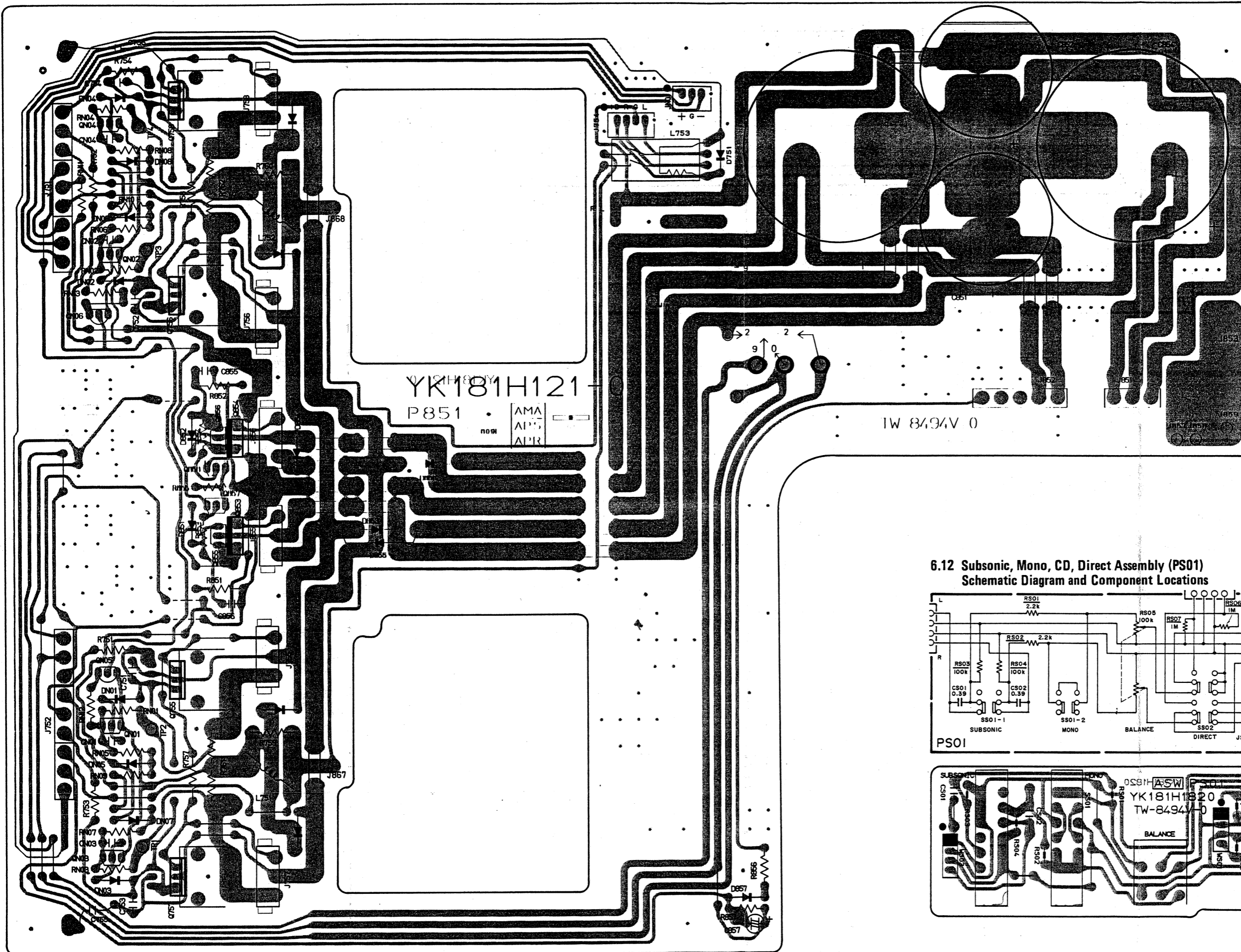

6.12 Subsonic, Mono, CD, Direct Assembly (PS01)  
Schematic Diagram and Component Locations

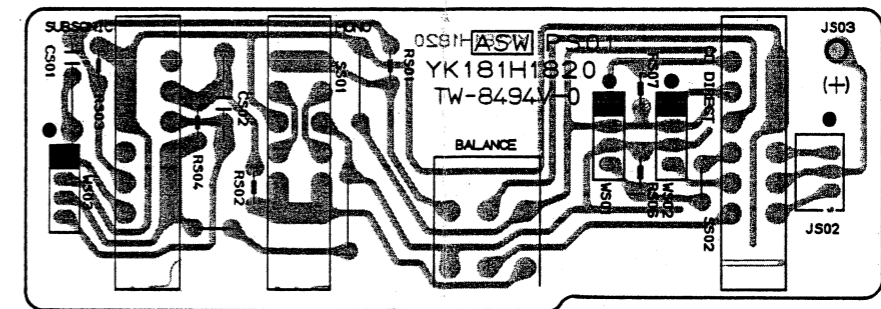
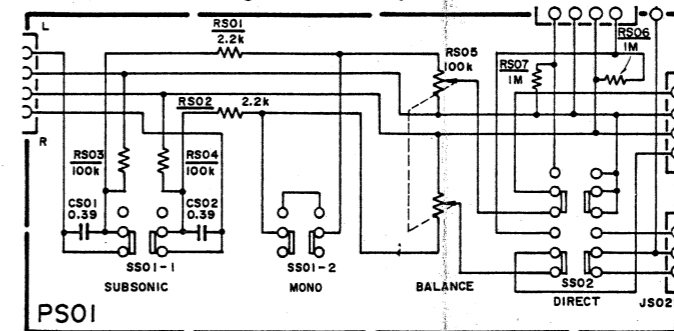

6.13 Flat/Tone Amp Assembly (PE01) Schematic Diagram and Component Locations

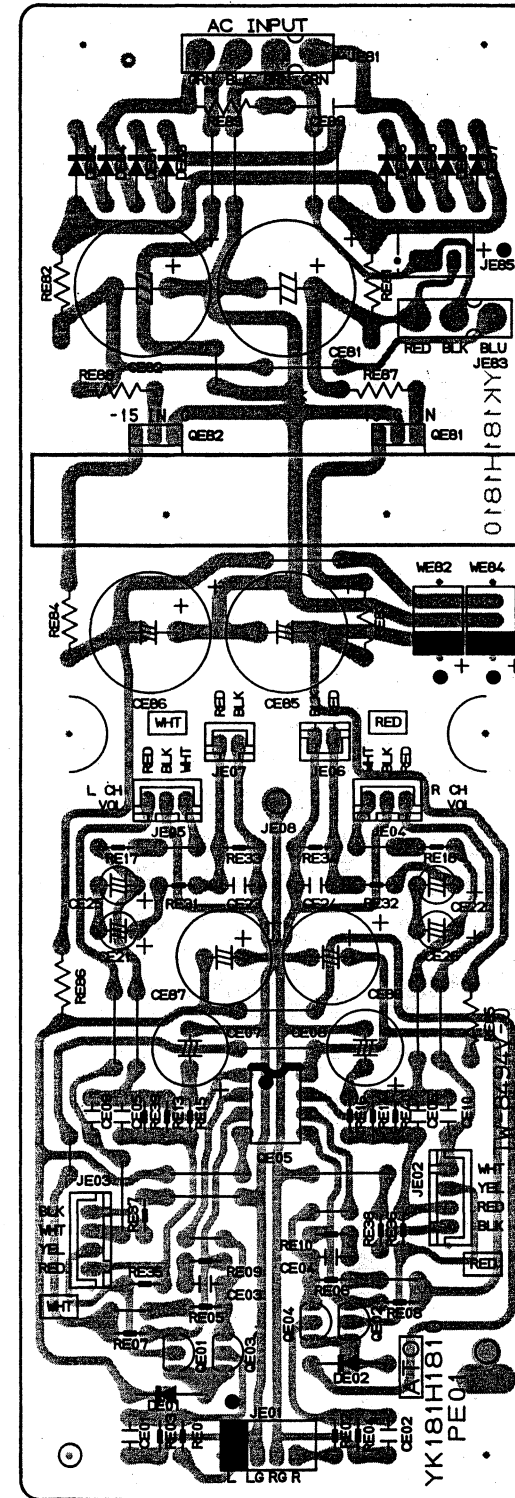
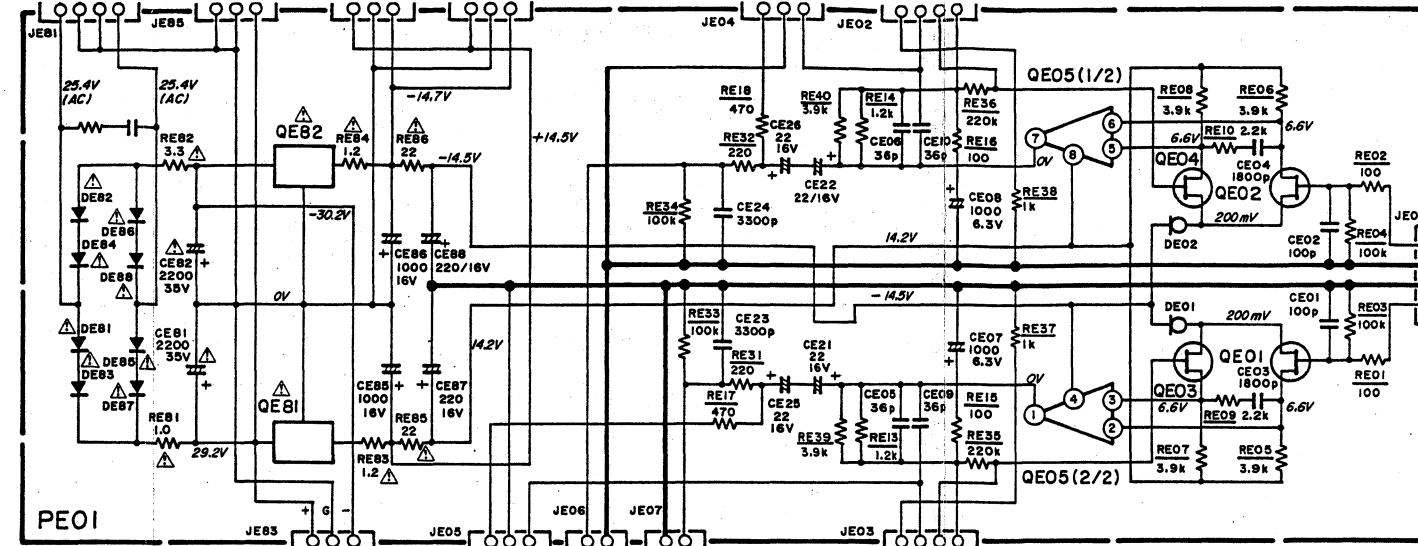

6.14 Tone Volume (R) Assembly (PF01) Schematic Diagram and Component Locations

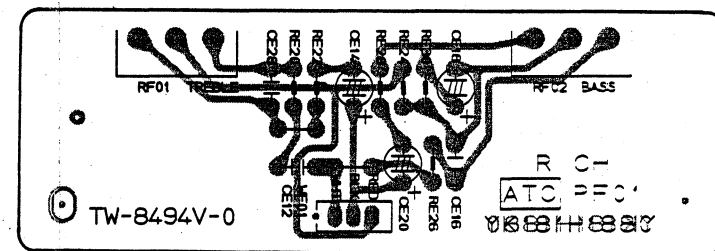
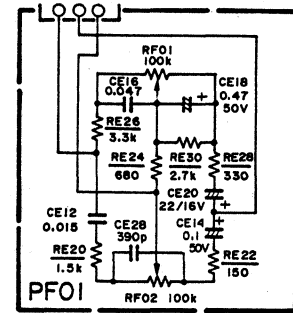

6.15 Tone Volume (L) Assembly (PF51) Schematic Diagram and Component Locations

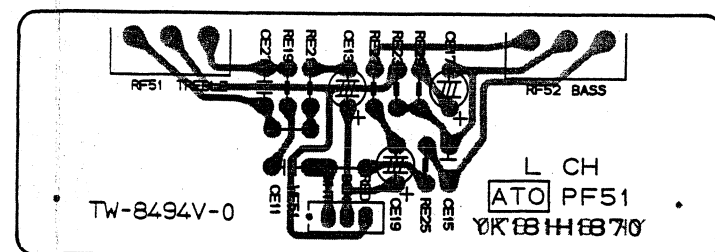
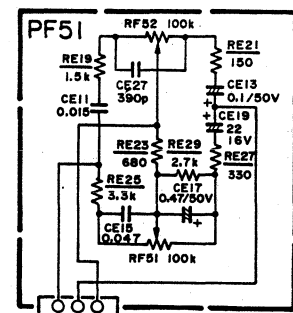

**6.16 Headphone, Speaker, Switch Assembly (PW51) Schematic Diagram and Component Locations**

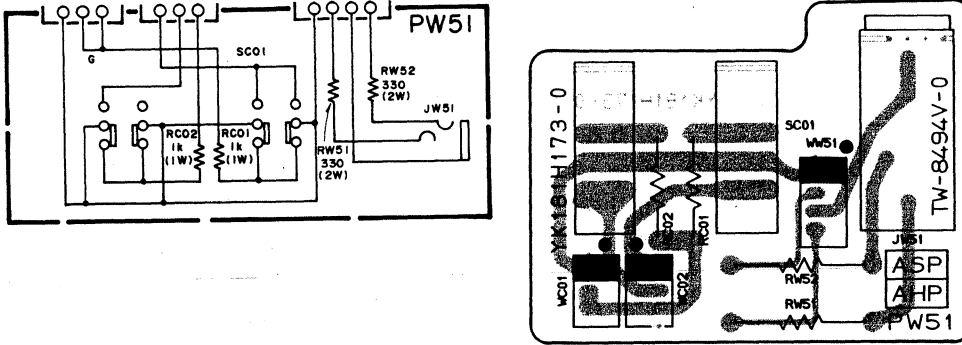

**6.17 Master Volume Assembly (PG01) Schematic Diagram and Component Locations**

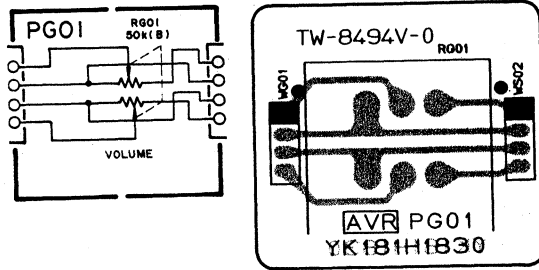

**6.18 Function LED Assembly (PY01) Schematic Diagram and Component Locations**

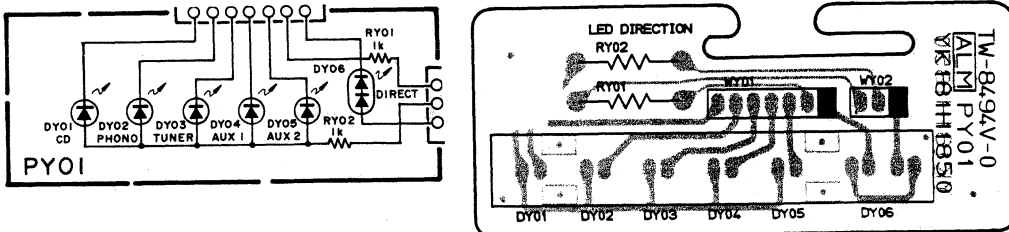

M 70 26

# 7. EXPLODED VIEW AND PARTS LIST

[C01-99] Front Panel and Chassis

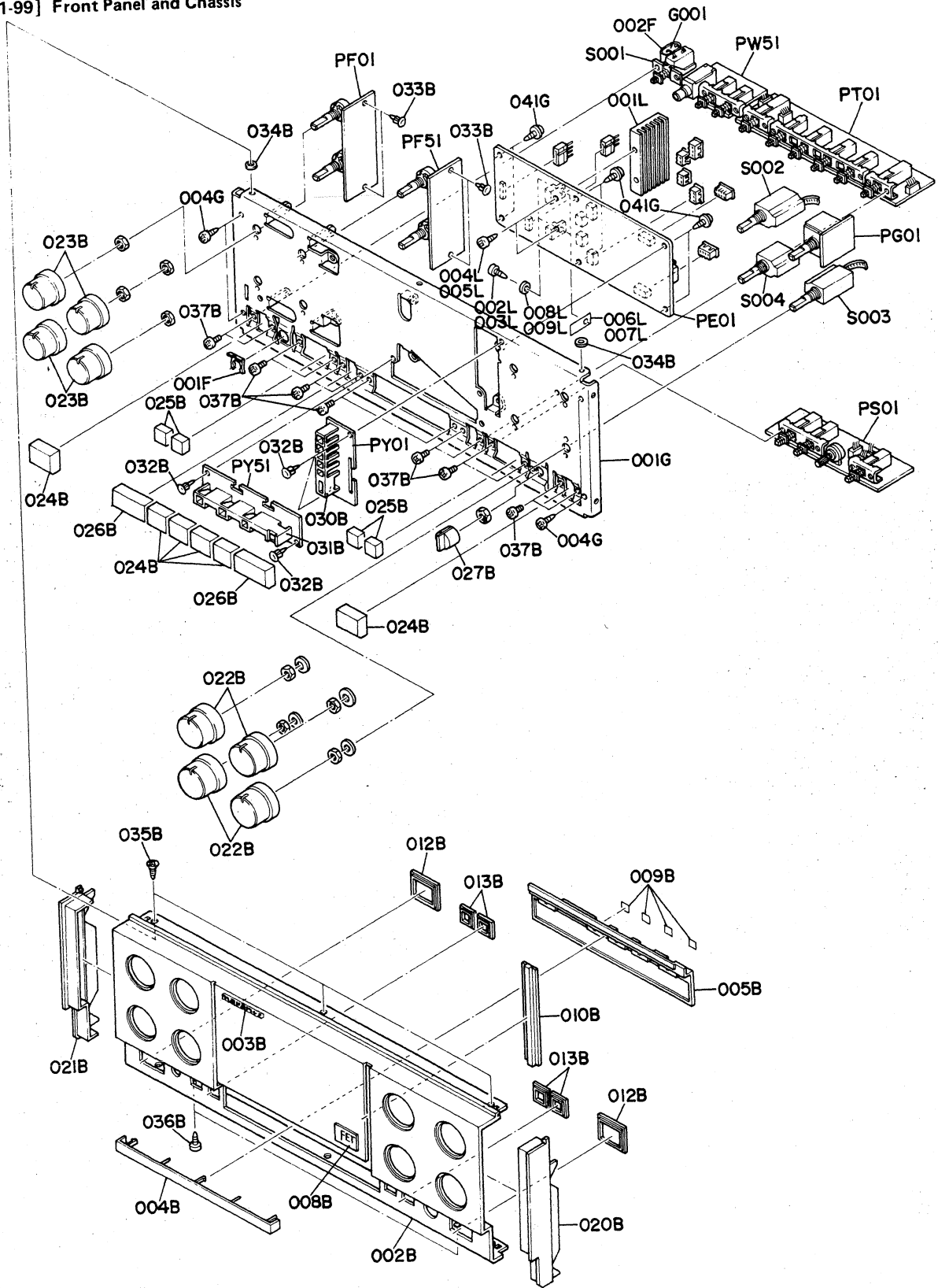

TH

M7027



- (N): for Europe
- (E): for Europe
- (A): for Australia
- (F): for Japan

REF. DESIG.	PART NO.	DESCRIPTION
		<b>PM-84MK11</b>
A	181H248400	Front Panel Assembly (Black)
A1	181H248410	Front Panel Assembly (Gold)
002B	181H248010	Front Panel (Black)
	181H248030	Front Panel (Gold)
003B	274H251020	Badge, Marantz
004B	274H053010	Cover, Bushing (Black)
	274H053110	Cover, Bushing (Gold)
005B	274H259510	Bushing, (K)
008B	274H251010	Badge, MOS FET.
010B	274H158010	Window
012B	242H259120	Bushing, Power/CD Direct (Black)
	242H259020	Bushing, Power/CD Direct (Gold)
013B	242H259130	Bushing, Speaker/Mono (Black)
	242H259030	Bushing, Speaker/Mono (Gold)
020B	242H067110	Cap, Right, Side (Black) [N, E, A]
	242H067010	Cap, Right Side (Gold) [N, E, A]
021B	242H067120	Cap, Left Side (Black) [N, E, A]
	242H067020	Cap, Left Side (Gold) [N, E, A]
		<b>PM-84D</b>
A	181H248420	Front Panel Assembly
002B	181H248020	Front Panel
003B	274H251020	Badge, Marantz
004B	274H053010	Cover, Bushing
005B	274H259510	Bushing, (K)
008B	274H251010	Bushing, MOS FET.
010B	274H158010	Window
012B	242H259120	Bushing, Power/CD Direct
013B	242H259130	Bushing, Speaker/Mono
009B	274H151010	Introducer
022B	242H154210	Knob, (Black)
	242H154310	Knob, (Gold)
023B	242H154220	Knob, (Black)
	242H154320	Knob, (Gold)
024B	242H270110	Button, Power/CD/Phono (Black)
	242H270010	Button, Power/CD/Phono (Gold)
025B	242H270120	Button, (Black)
	242H270020	Button, (Gold)
026B	274H270010	Button, Tone Defeat/Muting (Black)
	274H270110	Button, Tone Defeat/Muting (Gold)
027B	263H154130	Knob, Balance (Black)
	263H154030	Knob, Balance (Gold)
030B	274H271010	Holder, Function LED
031B	274H271020	Holder, Tape Monitor LED
032B	2276005050	Clamper
033B	2276005050	Clamper
034B	2232118300	Spacer
035B	51500308M0	F.H. Taptite Screw F3 x 8
036B	51280308M0	B.H. Tapped Screw B3 x 8
037B	51100306M0	B.H.M. Screw B3 x 6

REF. DESIG.	PART NO.	DESCRIPTION
001G	274H105120	Chassis, Front
004G	51280308M0	B.H. Tapped Screw B3 x 8
041G	51260308M0	B.T. Screw B3 x 8
001L	274H267030	Heatsink
002L	51280308M0	B.H. Tapped Screw B3 x 8
003L	51280308M0	B.H. Tapped Screw B3 x 8
004L	51260306M0	B.T. Screw B3 x 6
005L	51260306M0	B.T. Screw B3 x 6
006L	127H120010	Insulator
007L	127H120010	Insulator
008L	127H120020	Insulator, Bush
009L	127H120020	Insulator, Bush
Δ G001	DK18103840 BF10400060	Ceramic Cap. 0.01μF [N, E, A] Spark Killer 120Ω/0.1μF [F]
Δ S001	SP01010820	Push Switch, Power
S002	SR00050220	Rotary Switch, Selector
S003	SR00030120	Rotary Switch, Tape Copy
S004	SR00030130	Rotary Switch, Phone
001F	198T114010	Stopper, Headphone Jack
002F	139T120200	Insulator

[C02-99] Lid and Packing Materials

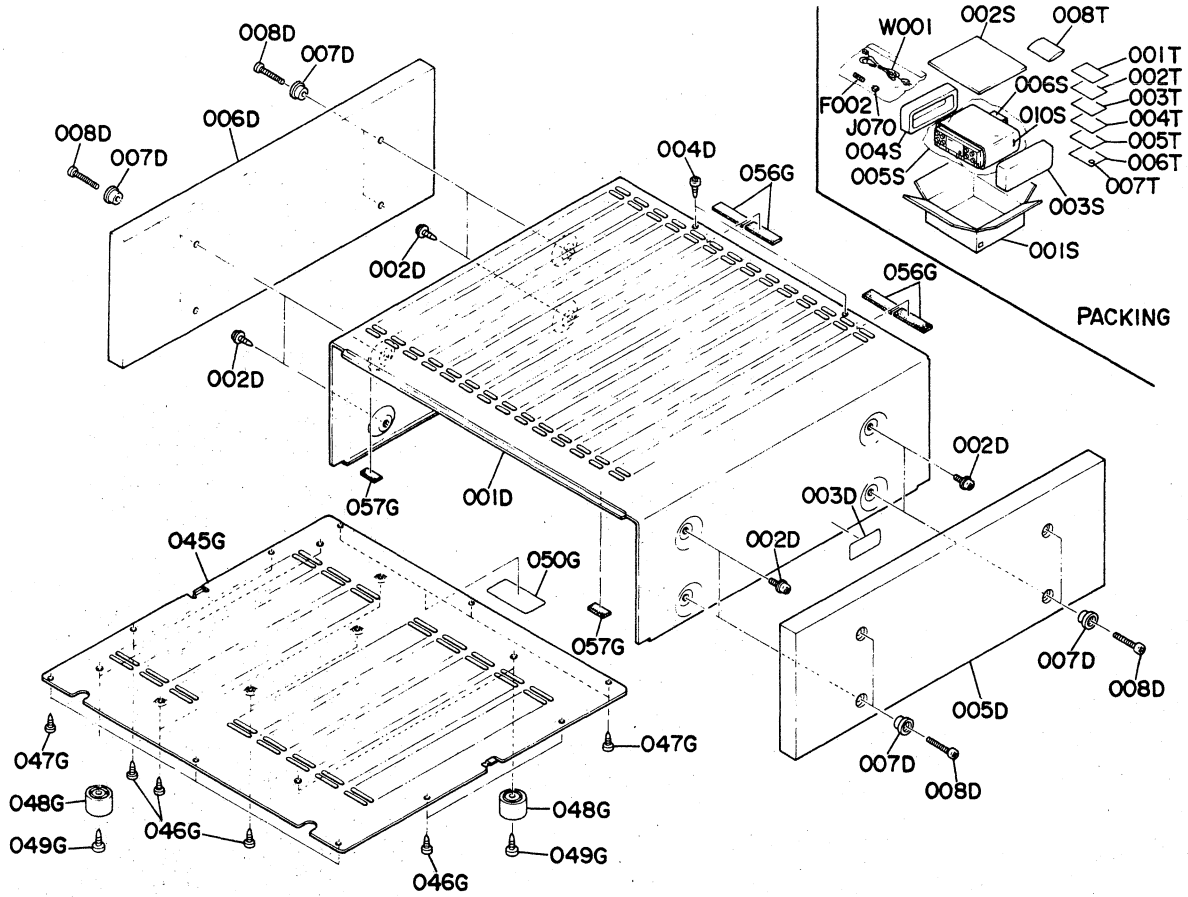

REF. DESIG.	PART NO.	DESCRIPTION
001D	242H257050	Lid, Top Cover; (Black)
	242H257040	Lid, Top Cover; (Gold)
	242H257030	Lid, Top Cover; (Black) [F]
002D	51260408M0	B.T. Screw B4 x 8 [N,E,A]
003D	2911861140	Label, Caution [N, E, A]
004D	51280308M0	B.H. Tapped Screw B3 x 8 [N,E,A]
	274H010010	Screw [F]
005D	181H249110	Side Panel, Right
006D	181H249120	Side Panel, Left
007D	3906259010	Bushing
008D	51280430M0	B.H. Tapped Screw B4 x 30
045G	242H257020	Lid, Bottom Cover
046G	51280308M0	B.H. Tapped Screw B3 x 8
047G	51280308M0	B.H. Tapped Screw B3 x 8
048G	2759057010	Leg [N, E, A]
	2759057020	Leg [F]
049G	51280410M0	B.H. Tapped Screw B4 x 10
050G	2911861110	Label, Caution
056G	2965118010	Spacer
057G	242H118010	Spacer

REF. DESIG.	PART NO.	DESCRIPTION
		<b>PACKING</b>
001S	181H801010	Packing Case [N, A]
	181H801020	Packing Case [E]
	181H801030	Packing Case [F]
002S	181H807010	Reinforcing [E]
003S	242H809010	Cushion, Right
004S	242H809020	Cushion, Left
005S	9091111030	Polyethylene Sheet
006S	2864804010	Sleeve, AC Cord
010S	181H107010	Sheet
001T	181H851310	User Manual [N, E, A]
	181H851110	User Manual [F]
002T	181H851320	User Manual, Spec [N, E, A]
003T	181H856010	Circuit Diagram [N, E]
004T	9631000090	Warranty Card [A]
	9631000130	Warranty Card [F]
005T	128T854010	Warranty Card [F]
006T	9611000050	User's Card [F]
007T	9540000010	License [F]
008T	9012540010	Polyethylene Bag
△ F002	FS10800700	Fuse 8A 250V [E]
△ J070	YJ04001240	Jack, AC Adapter
△ W001	ZC01805030	A.C. Power Cord [N]
	ZC02006030	A.C. Power Cord [A]

Th

M 7020

[C03-99] Rear Panel

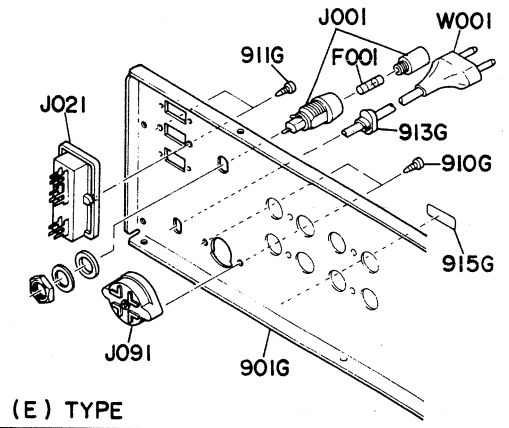
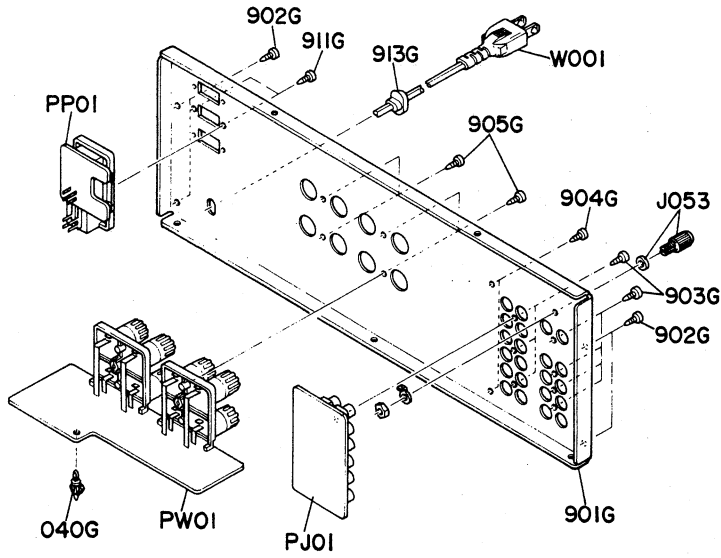

(E) TYPE

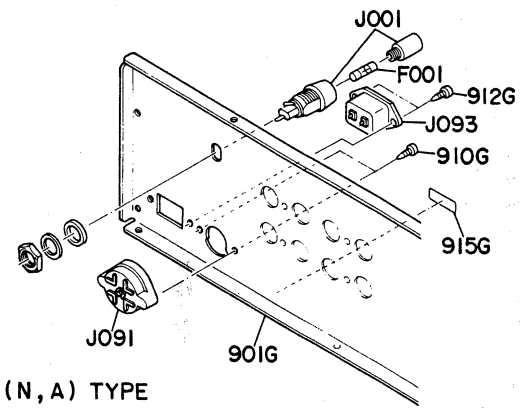

(N, A) TYPE

REF. DESIG.	PART NO.	DESCRIPTION
040G	3896101010	Support, Speaker P.W. Board
901G	181H250020	Rear Panel [N, A]
	181H250030	Rear Panel [E]
	181H250010	Rear Panel [F]
902G	51280308M0	B.H. Tapped Screw B3 x 8
903G	51280308M0	B.H. Tapped Screw B3 x 8
904G	51280308M0	B.H. Tapped Screw B3 x 8
905G	51280308M0	B.H. Tapped Screw B3 x 8
910G	51280308M0	B.H. Tapped Screw B3 x 8 [N,E,A]
911G	51280308M0	B.H. Tapped Screw B3 x 8 [E, F]
912G	51280308M0	B.H. Tapped Screw B3 x 8 [N, A]
913G	1455259210	Bushing, AC Power Cord [E, F]
915G	4581861010	Label, Made in Japan [N, E, A]

REF. DESIG.	PART NO.	DESCRIPTION
Δ F001	FS10400850	Fuse T4.0A 250V [N, A]
	FS10400700	Fuse 4.0A 250V [E]
Δ J001	YJ08000290	Jack, Fuse Holder [N, E, A]
Δ J021	YJ04000730	Jack, AC Outlet [E, F]
J053	YT01010150	Terminal, GND
Δ J091	BY05030040	Voltage Selector [N, A]
	BY05080040	Voltage Selector [E]
Δ J093	YP04000610	Plug, AC Inlet
Δ W001	YC01800240	A.C. Power Cord [E, F]

M7030

[P01-99] Main Chassis

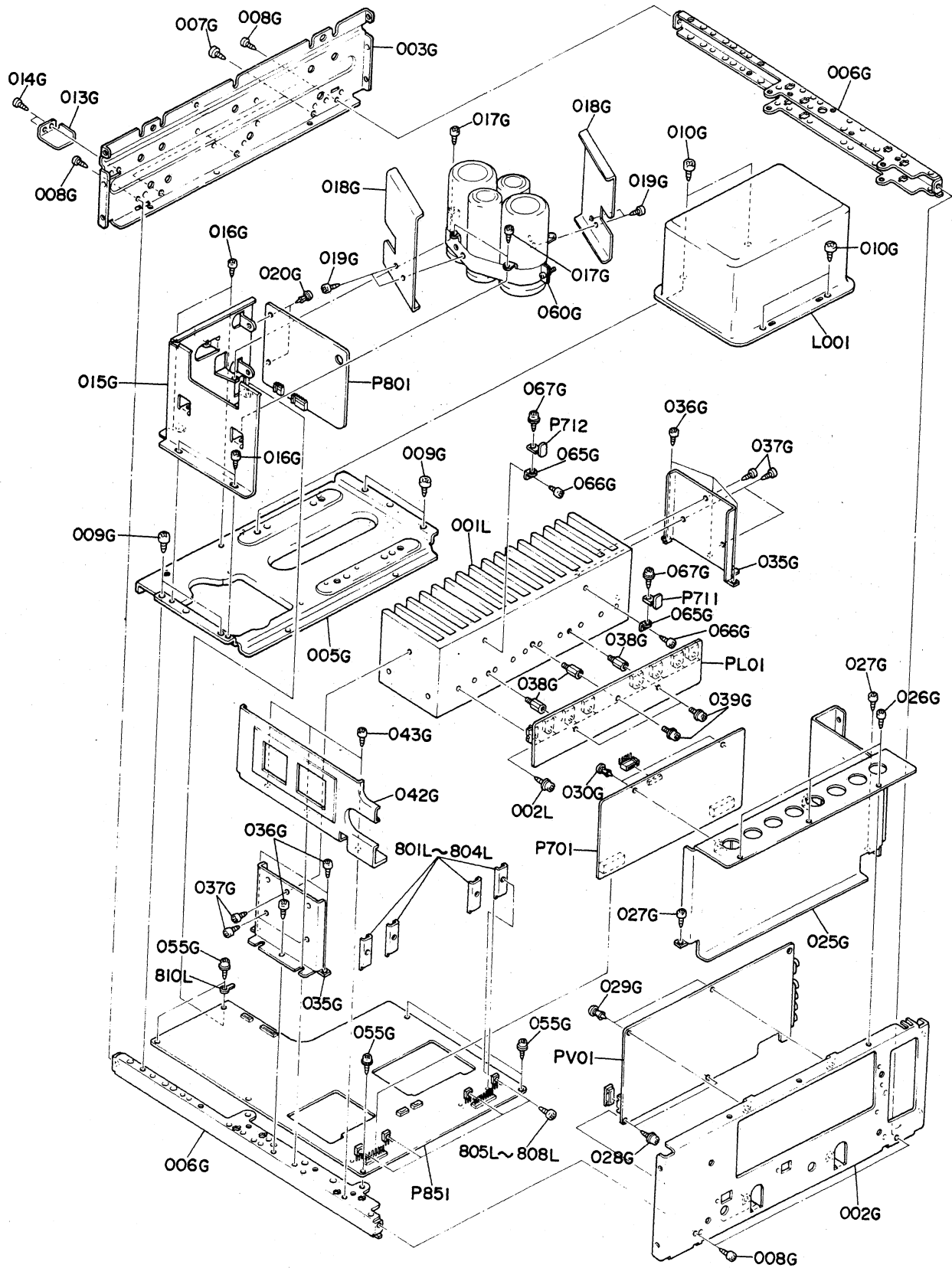

REF. DESIG.	PART NO.	DESCRIPTION
002G	242H105020	Chassis, Right Side
003G	242H105130	Chassis, Left Side
005G	242H105040	Chassis, Transformer
006G	242H104010	Retainer, Center
007G	51280410M0	B.H. Tapped Screw B4 x 10
008G	51280308M0	B.H. Tapped Screw B3 x 8
009G	51280410M0	B.H. Tapped Screw B4 x 10
010G	51280410M0	B.H. Tapped Screw B4 x 10
013G	181H109030	Shield
014G	51280308M0	B.H. Tapped Screw B3 x 8
015G	242H104020	Retainer, Cemicon
016G	51280308M0	B.H. Tapped Screw B3 x 8
017G	51280308M0	B.H. Tapped Screw B3 x 8
018G	181H104010	Retainer, Cemicon Block
019G	51280306M0	B.H. Tapped Screw B3 x 6
020G	2276005050	Clamper
025G	181H109010	Shield
026G	51280308M0	B.H. Tapped Screw B3 x 8
027G	51280308M0	B.H. Tapped Screw B3 x 8
028G	51260308M0	B.T. Screw B3 x 8
029G	2276005050	Clamper
030G	2276005050	Clamper
035G	242H104030	Retainer, Heatsink
036G	51280308M0	B.H. Tapped Screw B3 x 8
037G	51280308M0	B.H. Tapped Screw B3 x 8

REF. DESIG.	PART NO.	DESCRIPTION
038G	181H101010	Support
039G	51100306M0	B.H.M. Screw B3 x 6
042G	181H109020	Shield
043G	51280308M0	B.H. Tapped Screw B3 x 8
055G	51260308M0	B.T. Screw B3 x 8
060G	181H121010	Link, Cemicon
065G	2231160040	Bracket
066G	51280308M0	B.H. Tapped Screw B3 x 8
067G	51260308M0	B.T. Screw B3 x 8
001L	181H267010	Heatsink, Main
002L	51260312M0	B.T. Screw B3 x 12
801L	181H267020	Heatsink
802L	181H267020	Heatsink
803L	181H267020	Heatsink
804L	181H267020	Heatsink
805L	51260308M0	B.T. Screw B3 x 8
806L	51260308M0	B.T. Screw B3 x 8
807L	51260308M0	B.T. Screw B3 x 8
808L	51260308M0	B.T. Screw B3 x 8
810L	62030049W0	Lug, Earth
ΔL001	TS60508160	Power Transformer [N, A]
	TS60508170	Power Transformer [E]
	TS60508180	Power Transformer [F]

M7032

## 8. ELECTRICAL PARTS LIST

- (N): for Europe
- (E): for Europe
- (A): for Australia
- (F): for Japan

### ASSIGNMENT OF COMMON PARTS CODES.

#### RESISTOR

R\*\*\*: (1) GD05 --- 140, Carbon film fixed resistor, ±5%, 1/4W

R\*\*\*: (2) GD05 --- 160, Carbon film fixed resistor, ±5%, 1/6W

① — Resistance value

#### Examples

① Resistance value

0.1Ω...001	10Ω...100	1kΩ...102	100kΩ...104
0.5Ω...005	18Ω...180	2.7kΩ...272	680kΩ...684
1Ω...010	100Ω...101	10kΩ...103	1MkΩ...105
6.8Ω...068	390Ω...391	22kΩ...223	4.7MkΩ...475

(Note) Please distinguish 1/4W from 1/6W by the shape of parts used actually.

#### C\*\*\*: CERAMIC CAP.

(1) DD1 --- 370, Ceramic condenser  
Disc type  
Temp. coeff. P350 ~ N1000, 50V

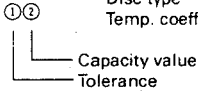

#### Examples

① Tolerance (Capacity deviation)

±0.25pF...0
±0.5pF...1
±5%...5

\* Tolerance of COMMON PARTS handled here are as follows:

0.5pF ~ 5pF...±0.25pF
6pF ~ 10pF...±0.5pF
12pF ~ 560pF...±5%

② Capacity value

0.5pF...005	3pF...030	100pF...101
1pF...010	10pF...100	220pF...221
1.5pF...015	47pF...470	560pF...561

#### C\*\*\*: CERAMIC CAP.

(1) DK16 --- 300, High dielectric constant ceramic condenser  
Disc type  
Temp. chara. 2B4, 50V

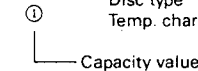

#### Example

② Capacity value

100pF...101	1000pF...102	10000pF...103
470pF...471	2200pF...222	

#### C\*\*\*: ELECTROLY CAP. ( ⚡ ), FILM CAP. ( ⚡ )

(1) EA --- 10, Electrolytic condenser  
One-way lead type, Tolerance ±20%

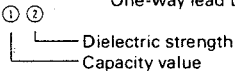

#### Examples

① Capacity value

0.1μF...104	4.7μF...475	100μF...107
0.33μF...334	10μF...106	330μF...337
1μF...105	22μF...226	1100μF...108
		2200μF...228

② Working voltage

6.3V...006	25V...025
10V...010	35V...035
16V...016	50V...050

(2) DF15 --- 350, Plastic film condenser

One-way type, Mylar ±5% 50V

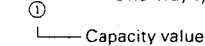

#### Examples

① Capacity value

0.001μF (1000pF)...102	0.1μF...104
0.0018μF...182	0.56μF...564
0.01μF...103	1μF...105
0.015μF...153	

REF. DESIG.	PART NO.	DESCRIPTION
P701	YK181H1710 ZZ181H8710	<b>P701-VOLTAGE AMP CIRCUIT BOARD</b> P.W. Board, Voltage Amp P.W. Board Assembly
		<b>P701-CAPACITORS</b>
CN51	OA47405010	Elect 0.47μF 50V
CN52	EQ33505030	Elect 3.3μF 50V (B, P)
CN53	OA47602510	Elect 47μF 25V
CN54	OA22601610	Elect 22μF 16V
CU01	OF15332010	Film 3300pF ±5%
CU02	OF15332010	Film 3300pF ±5%
CU03	DF35220520	Mica 22pF ±5%
CU04	DF35220520	Mica 22pF ±5%
CU05	OA10602510	Elect 10μF 25V
CU06	OA10602510	Elect 10μF 25V
CU07	DF35220520	Mica 22μF ±5%
CU08	OF15102010	Mica 1000pF ±5%
CU09	OA10601610	Elect 10μF 16V
CU10	OA10601610	Elect 10μF 16V
CU11	OA47601010	Elect 47μF 10V
C701	DF55151520	Film 150pF ±5%
C702	DF55151520	Film 150pF ±5%
C703	OA10601610	Elect 10μF 16V
C704	OA10601610	Elect 10μF 16V
C705	OF15152010	Film 1500pF ±5%
C706	OF15152010	Film 1500pF ±5%
C707	DF35101520	Mica 100pF ±5%
C708	DF35101520	Mica 100pF ±5%
C711	OA22701610	Elect 220μF 16V
C712	OA22701610	Elect 220μF 16V
C713	DF31050520	Mica 5pF ±0.5pF
C714	DF31050520	Mica 5pF ±0.5pF
C715	OF15223010	Film 0.022μF ±5%
C716	OF15223010	Film 0.022μF ±5%
C717	OF15473010	Film 0.047μF ±5%
C718	OF15473010	Film 0.047μF ±5%
C719	OA10701610	Elect 100μF 16V
C720	OA10701610	Elect 100μF 16V
C721	OA22710010	Elect 220μF 100V
C722	OA22710010	Elect 220μF 100V
		<b>P701-RESISTORS</b>
RU19	GA05221010	220Ω ±5% 1W
R723	RA02230760	22KΩ, Trimming
ΔR735	NH05220140	220Ω ±5% ¼W, Fusible
ΔR736	NH05220140	220Ω ±5% ¼W, Fusible
		<b>P701-SEMICONDUCTORS</b>
DU01	HD20011050	Diode 1S1555
DU02	HD20011050	Diode 1S1555
DU03	HD20011050	Diode 1S1555
DU04	HD20011050	Diode 1S1555
DU05	HD30001020	Zener MA1033
DU06	HD30001020	Zener MA1033
DU07	HD30004020	Zener MA1051
DU08	HD20011050	Diode 1S1555
DU09	HD20011050	Diode 1S1555
QN51	HC10042050	IC TA7317P
ΔQN52	HT109701A0	Transistor 2SA970(GR)

REF. DESIG.	PART NO.	DESCRIPTION
QU01	HC10009090	IC NJM2901
QU02	HC712301A0	IC 74LS123P
QU03	HT327852C0	Transistor 2SC2785(EF, FF)
QU04	HT327852C0	Transistor 2SC2785(EF, FF)
QU05	HW10005320	Photo Unit PC847
Q701	HC10141030	IC STK3122
Q705	HT110152A0	Transistor 2SA1015(O, Y)
Q706	HT110152A0	Transistor 2SA1015(O, Y)
JN51	YJ06002430	<b>P701-MISCELLANEOUS</b> Jack, 3P
J701	YP06001050	Plug, 5P
J702	YJ06001250	Jack, 5P
J703	YJ06001430	Jack, 9P
J704	YJ06001430	Jack, 9P
W701	YU03220260	Jumper Lead, 3P
W702	YU03220260	Jumper Lead, 3P
P711	YK181H1750 ZZ181H8750	<b>P711-POWER AMP BIAS TRANSISTOR CIRCUIT BOARD</b> P.W. Board, Power Amp Bias Transistor P.W. Board Assembly
Q703	HT334191Y0	Transistor 2SC3419(Y)
P721	YK181H1740 ZZ181H8740	<b>P721-POWER AMP BIAS TRANSISTOR CIRCUIT BOARD</b> P.W. Board, Power Amp Bias Transistor P.W. Board Assembly
Q704	HT334191Y0	Transistor 2SC3419(Y)
P801	YK181H1220 ZZ181H8220	<b>P801-MAIN POWER DIODE CIRCUIT BOARD</b> P.W. Board, Main Power Diode P.W. Board Assembly
C801	DF16104510	Film Cap. 0.1µF ±10%
C802	DF16104510	Film Cap. 0.1µF ±10%
Δ D801	HE20009290	Diode S5VB20
Δ D802	HE20013290	Diode D5FB20
J802	YJ06001240	Jack, 3P
J803	YJ06001250	Jack, 5P
P851	YK181H1210 ZZ181H8210	<b>P851-MAIN POWER SUPPLY CIRCUIT BOARD</b> P.W. Board, Main Power Supply P.W. Board Assembly
CN01	OF15102010	Film 1000pF ±5%
CN04		
C751		
C754	DF35101520	Mica 100pF ±5%

REF. DESIG.	PART NO.	DESCRIPTION
Δ C851	EC16904510	Elect 16000µF 45V
Δ C852	EC16904510	Elect 16000µF 45V
Δ C853	EC22907520	Elect 22000µF 75V
Δ C854	EC22907520	Elect 22000µF 75V
C855	DF35221520	Mica 220pF ±5%
C856	DF35221520	Mica 220pF ±5%
C857	OA10505010	Elect 1µF 50V
<b>P851-RESISTORS</b> (All Resistors are ±5% and ¼W)		
RN01	GG05331140	330Ω
RN02	GG05331140	330Ω
RN03	GG05331140	330Ω
RN04	GG05331140	330Ω
RN05	GG05472140	4.7KΩ
RN06	GG05472140	4.7KΩ
RN07	GG05472140	4.7KΩ
RN08	GG05472140	4.7KΩ
RN12	GG05472140	4.7KΩ
RN13	GG05472140	4.7KΩ
R751	NH05470140	470Ω
R752	NH05470140	470Ω
R753	NH05470140	470Ω
R754	NH05470140	470Ω
R757	GG05151120	150Ω ¼W
R758	GG05151120	150Ω ¼W
R759	GG05022120	2.2Ω ¼W
R760	GG05022120	2.2Ω ¼W
R761	BW10000050	0.1Ωx2 ±10% 5W, Composite
R762	BW10000050	0.1Ωx2 ±10% 5W, Composite
Δ R851	GG05222120	2.2KΩ ¼W
Δ R852	GG05222120	2.2KΩ ¼W
Δ R853	GG05222120	2.2KΩ ¼W
Δ R854	GG05222120	2.2KΩ ¼W
Δ R855	GG05102140	1KΩ
<b>P851-SEMICONDUCTORS</b>		
DN01		
DN08	HD20014010	Diode 1SS81
D751	HD20011050	Diode 1S1555
Δ D851	HD20011050	Diode 1S1555
Δ D852	HD20011050	Diode 1S1555
Δ D853	HD20022030	Diode DSF10C
Δ D854	HD20022030	Diode DSF10C
Δ D855	HD20027100	Diode 30DF-2
Δ D856	HD20027100	Diode 30DF-2
D857	HD20022030	Diode DSF10C
QN01	HT322402A0	Transistor 2SC2240(GR, BL)
QN02	HT322402A0	Transistor 2SC2240(GR, BL)
QN03	HT109702A0	Transistor 2SA970(GR, BL)
QN04	HT109702A0	Transistor 2SA970(GR, BL)
QN05	HT322402A0	Transistor 2SC2240(GR, BL)
QN06	HT322402A0	Transistor 2SC2240(GR, BL)
Q755	HT326823A0	Transistor 2SC2682(P, Q, R)
Q756	HT326823A0	Transistor 2SC2682(P, Q, R)
Q757	HT111423A0	Transistor 2SA1142(P, Q, R)
Q758	HT111423A0	Transistor 2SA1142(P, Q, R)

REF. DESIG.	PART NO.	DESCRIPTION
Δ Q851	HT335193A0	Transistor 2SC3519(O, P, Y)
Δ Q852	HT113863A0	Transistor 2SA1386(O, P, Y)
Δ Q853	HT332982D0	Transistor 2SC3298(O, Y)
Δ Q854	HT113062D0	Transistor 2SA1306(O, Y)
Δ Q855	HT322402A0	Transistor 2SC2240(GR, BL)
Δ Q856	HT109702A0	Transistor 2SA970(GR, BL)
Δ Q857	HT322402A0	Transistor 2SC2240(GR, BL)
Δ Q858	HT109702A0	Transistor 2SA970(GR, BL)
JN01	YJ06002430	<b>P851-MISCELLANEOUS</b> Jack, 3P
J751	YP06001070	Plug, 9P
J752	YP06001070	Plug, 9P
J754	YJ06002440	Jack, 4P
J755	YJ06006020	Jack, 3P
J756	YJ06006020	Jack, 3P
J757	YJ06006020	Jack, 3P
J758	YJ06006020	Jack, 3P
J851	YP06001040	Plug, 3P
J852	YP06001050	Plug, 5P
J853	YL01010110	Terminal, GND
J855	YJ05000390	Jack, 3P
J856	YJ05000390	Jack, 3P
L751	LL23905120	Coil
L752	LL23905120	Coil
L753	LY20240240	Relay, 24V
W801	YB00450160	Connective Cord
W802	YB00420180	Connective Cord
PE01	YK181H1810 ZZ181H8810	<b>PE01-FLAT TONE AMP CIRCUIT BOARD</b> P.W. Board, Flat Tone Amp P.W. Board Assembly
CE01	DF35101520	Mica 100pF ±5%
CE02	DF35101520	Mica 100pF ±5%
CE03	OF15182010	Film 1800pF ±5%
CE04	OF15182010	Film 1800pF ±5%
CE05	DF35360520	Mica 36pF ±5%
CE06	DF35360520	Mica 36pF ±5%
CE07	OA10800610	Elect 1000µF 6.3V
CE08	OA10800610	Elect 1000µF 6.3V
CE09	DF35360520	Mica 36pF ±5%
CE10	DF35360520	Mica 36pF ±5%
CE21	OA22601610	Elect 22µF 16V
CE22	OA22601610	Elect 22µF 16V
CE23	OF15332010	Film 3300pF ±5%
CE24	OF15332010	Film 3300pF ±5%
CE25	OA22601610	Elect 22µF 16V
CE26	OA22601610	Elect 22µF 16V
CE81	OA22803510	Elect 2200µF 35V
CE82	OA22803510	Elect 2200µF 35V
CE85	OA10801610	Elect 1000µF 16V
CE86	OA10801610	Elect 1000µF 16V
CE87	OA22701610	Elect 220µF 16V
CE88	OA22701610	Elect 220µF 16V

REF. DESIG.	PART NO.	DESCRIPTION
<b>PE01-RESISTORS</b> (All Resistor are ±5% and ¼W)		
Δ RE81	NH05010140	1Ω, Fusible
Δ RE82	NH05010140	1Ω, Fusible
Δ RE83	NH05012140	1.2Ω, Fusible
Δ RE84	NH05012140	1.2Ω, Fusible
Δ RE85	NH05220140	22Ω, Fusible
Δ RE86	NH05220140	22Ω, Fusible
<b>PE01-SEMICONDUCTORS</b>		
DE01	HD60001160	C.R. Diode 4.5mA
DE02	HD60001160	C.R. Diode 4.5mA
Δ DE81		
Δ DE88	HD20022030	Diode DSF-10C
QE01	HF203691B0	F.E.T. 2SK369BL
QE02	HF203691B0	F.E.T. 2SK369BL
QE03	HF203691B0	F.E.T. 2SK369BL
QE04	HF203691B0	F.E.T. 2SK369BL
QE05	HC10026090	IC NJM2041DD
Δ QE81	HC38515090	IC NJM78M15A
Δ QE82	HC39515090	IC NJM78M15A
<b>PE01-MISCELLANEOUS</b>		
JE01	YJ06002440	Jack, 4P
JE02	YP06003440	Plug, 4P
JE03	YP06003440	Plug, 4P
JE04	YP06003330	Plug, 3P
JE05	YP06003330	Plug, 3P
JE06	YP06003410	Plug, 2P
JE07	YP06003410	Plug, 2P
JE81	YP06004330	Plug, 4P
JE82	YJ06006010	Jack, 4P
JE83	YP06001040	Plug, 3P
JE84	YJ06001040	Jack, 3P
JE85	YJ06002430	Jack, 3P
WE82	YU03420260	Jumper Lead, 3P
WE84	YU03160260	Jumper Lead, 3P
PF01	YK181H1880 ZZ181H8880	<b>PF01-TONE VOLUME (R) CIRCUIT BOARD</b> P.W. Board, Tone Volume (R) P.W. Board Assembly
CE12	OF15153010	Film Cap. 0.015µF ±5%
CE14	OA10405010	Elect Cap. 0.1µF 50V
CE16	OF15473010	Film Cap. 0.047µF ±5%
CE18	OA47405010	Elect Cap. 0.47µF 50V
CE20	OA22601610	Elect Cap. 22µF 16V
CE28	DF55391530	Film 390pF ±5%
RF01	RK01030630	Variable Resistor 10KΩ(C)
RF02	RK01030630	Variable Resistor 10KΩ(C)
WF01	YB00160260	Connective Cord, 3P

M2034





REF. DESIG.	PART NO.	DESCRIPTION
LV01	LY20240230	Relay, SZ-2104
LV02	LY20240230	Relay, SZ-2104
SD01	SS04030260	Slide Switch
SV01	SS04060050	Slide Switch
SV02	SS06030220	Slide Switch
WV01	YU04140260	Jumper Lead, 4P
WV02	YU04120260	Jumper Lead, 4P
		<b>PW01-SPEAKER RELAY/TERMINAL CIRCUIT BOARD</b>
PW01	YK181H1720 ZZ181H8720	P.W. Board, Speaker Relay/Terminal P.W. Board Assembly
		<b>PW01-CAPACITORS</b>
CW01 }	OF15104010	Film 0.1 $\mu$ F $\pm$ 5%
		<b>PW01-RESISTORS</b>
RW01	GA05047030	4.7 $\Omega$ $\pm$ 5% 3W
RW02	GA05047030	4.7 $\Omega$ $\pm$ 5% 3W
		<b>PW01-SEMICONDUCTORS</b>
DW01	HD20011050	Diode 1S1555
DW02	HD20011050	Diode 1S1555
		<b>PW01-MISCELLANEOUS</b>
JW01	YT01040360	Terminal, Speaker (L)
JW02	YT01040370	Terminal, Speaker (R)
JW03	YJ06002430	Jack, 3P
JW04	YP06004330	Plug, 4P
JW05	YP06004330	Plug, 4P
LW01	LY20240150	Relay
LW02	LY20240150	Relay
WW01	YU03180260	Jumper Lead, 3P
WW02	YU03220260	Jumper Lead, 3P
		<b>PW51-HEADPHONE/SPEAKER CIRCUIT BOARD</b>
PW51	YK181H1730 ZZ181H8730	P.W. Board, Headphone/Speaker P.W. Board Assembly
RC01	GA05102010	Resistor 1K $\Omega$ $\pm$ 5% 1W
RC02	GA05102010	Resistor 1K $\Omega$ $\pm$ 5% 1W
RW51	GA05331020	Resistor 330 $\Omega$ $\pm$ 5% 2W
RW52	GA05331020	Resistor 330 $\Omega$ $\pm$ 5% 2W
JW51	YJ01002080	Jack, Headphone
SC01	SP02020860	Push Switch, Speaker
WC01	YU03160260	Jumper Lead, 3P
WC02	YU03560260	Jumper Lead, 3P
WW51	YU04200260	Jumper Lead, 4P

REF. DESIG.	PART NO.	DESCRIPTION
		<b>PY01-FUNCTION CIRCUIT BOARD</b>
PY01	YK181H1850 ZZ181H8850	P.W. Board, Function P.W. Board Assembly
RY01	GA05102010	Resistor 1K $\Omega$ $\pm$ 5% 1W
RY02	GA05102010	Resistor 1K $\Omega$ $\pm$ 5% 1W
DY01		
}	HI10048320	L.E.D. GL-3HD7
DY05		
DY06	HI10037320	L.E.D. LT-9200N
WY01	YU07320260	Jumper Lead, 7P
WY02	YU03180260	Jumper Lead, 3P
		<b>PY51-TAPE MONITOR CIRCUIT BOARD</b>
PY51	YK181H1840 ZZ181H8840	P.W. Board, Tape Monitor P.W. Board Assembly
DY51	HI10048320	L.E.D. GL-3HD7
DY52	HI10048320	L.E.D. GL-3HD7
DY53	HI10048320	L.E.D. GL-3HD7
DY54	HI10037320	L.E.D. LT-9200N

(W01-99)	Assembly and Wiring
(T01-99)	Adjustment
(X01-00)	Correction

**NOTE ON SAFETY :**

Symbol  $\Delta$  Fire or electrical shock hazard. Only original parts should be used to replace any part marked with symbol  $\Delta$ . Any other component substitution (other than original type), may increase risk of fire or electrical shock hazard.

M7036

## 9. TECHNICAL SPECIFICATIONS

### AUDIO SECTION

IHF Dynamic Power	
4 OHMS	300 W
8 OHMS	180 W

### POWER OUTPUT PER CHANNEL

DIN 4 OHMS	190 W
RMS 4 OHMS (20 Hz – 20 kHz THD 0.05%)	125 W
DIN 8 OHMS AT 1 kHz	140 W
RMS 8 OHMS (20 Hz – 20 kHz THD 0.03%)	100 W
TOTAL HARMONIC DISTORTION AT RMS 8 OHMS	0.015 %
I.M. DISTORTION	0.015 %
DAMPING FACTOR 8 OHMS (1 kHz)	100

### MM CARTRIDGE INPUT

Frequency Response (IEC RIAA)	±0.25 dB
Signal-to-Noise Ratio (IEC A weighted)	90 dB
Input Impedance	47 k ohms
Input Capacitance	200 pF
Input Sensitivity	2.5 mV
Equivalent Input Noise	0.22 µV
Dynamic Range	116 dB

### MC CARTRIDGE INPUT

Input Sensitivity	125 µV
Input Impedance	100 ohms

### CD-TUNER-TAPE INPUT

Input Impedance	30 k ohms
Input Sensitivity	150 mV
Frequency Response ±1.0 dB	15 Hz ~ 70 kHz
Signal to Noise Ratio (IEC A weighted)	98 dB

### OUTPUT VOLTAGE

Tape Out [7.75 mV PHONO (MM) Input]	465 mV
-------------------------------------	--------

### OUTPUT IMPEDANCE

Tape Out (Source PHONO)	220 ohms
-------------------------	----------

### GENERAL

Power Requirements	N and T versions	220/240 V AC, 50/60 Hz
	E version	110/120/220/240 V AC, 50/60 Hz
Power Consumption at Rated Output, both Channels Operating		490 W
Dimensions		
Panel Width		416 mm
Panel Height		146 mm
Depth		410 mm
Weight		
Unit Alone		18.0 kg

10. SCHEMATIC DIAGRAM

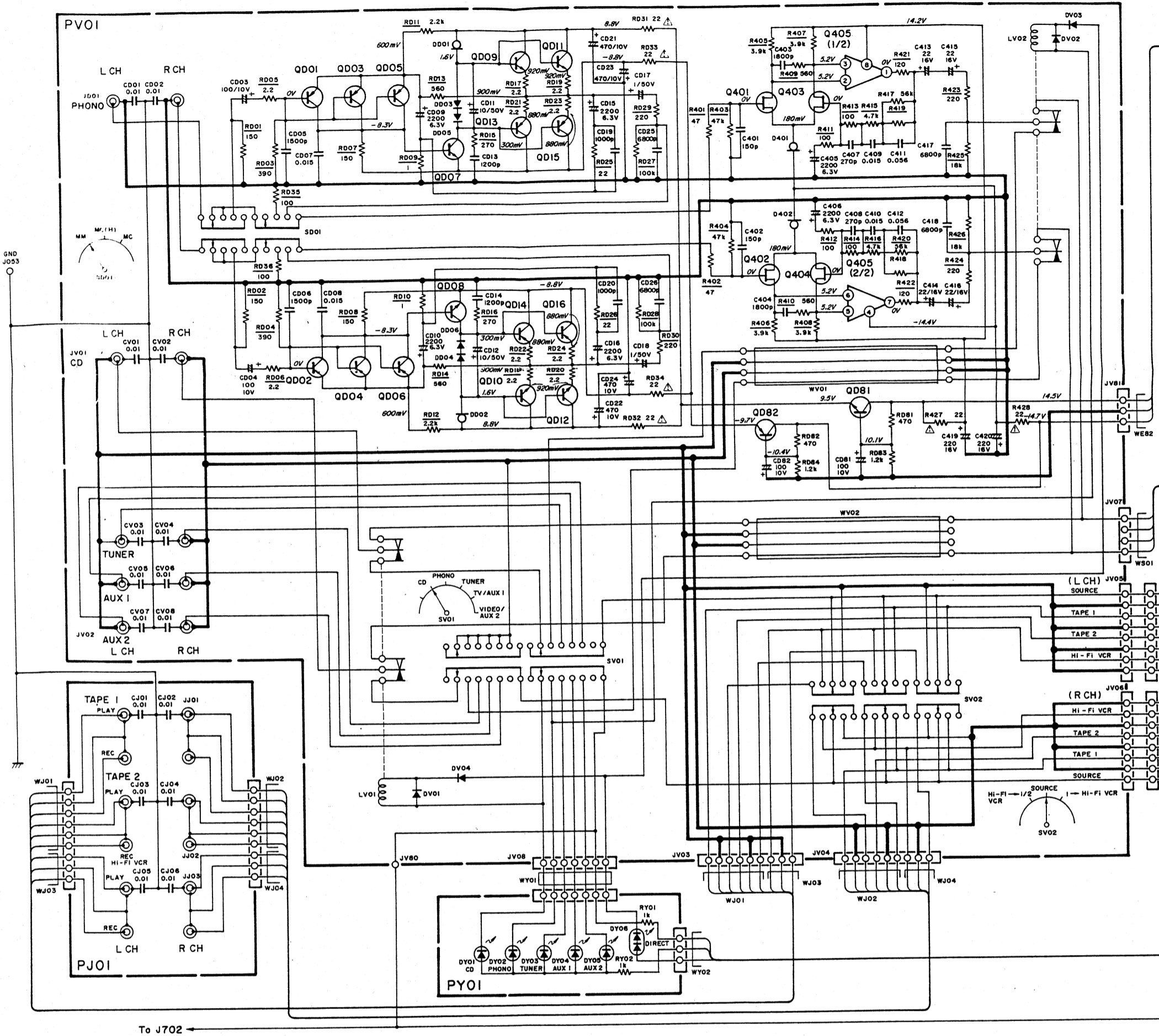

To J702 ←

Q401 ~ Q404  
QE01 ~ QE04  
HF203691B0  
25K3698L

Q405, QE05  
HC10026090  
NJM2041DD

QD01 ~ QD06, QD13 ~ QD16  
HT113162A0  
25A1316 (GR, BL)

QD07 ~ QD12  
HT333292A0  
25C3329 (GR, BL)

QD81  
HT332982D0  
25C3298 (O, Y)

QD82  
HT113062D0  
25A1306 (O, Y)

QE81  
HC38515090  
NJM78M15A

QE82  
HC39515090  
NJM79M15A

D401, D402  
DD01, DD02, DE01, DE02  
HD6001160  
C.R.D/4.5MA

DD03 ~ DD06, DV01 ~ DV04  
HD20002000  
ISS133

DE81 ~ DE88  
HD20022030  
DSF-10C

DY01 ~ DY05  
DY51 ~ DY53  
HI10048320  
LED GL-3HD7

DY06, DY54  
HI10037320  
L.E.D LT-9200N

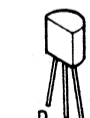

25K3698L

TOP VIEW

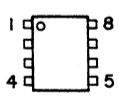

NJM2041DD

25C3298 (O, Y)

- |      |            |                        |
|------|------------|------------------------|
| F001 | FS10400850 | FUSE [N, A]            |
|      | FS10400700 | FUSE [E]               |
| L001 | TS60508160 | POWER TRANSF. [N, A]   |
|      | TS60508170 | POWER TRANSF. [E]      |
| S001 | SP01010820 | PUSH SWITCH POWER      |
| S002 | SR00050220 | ROTARY SWITCH FUNCTION |
| S003 | SR00030120 | ROTARY SWITCH REC MODE |
| S004 | SR00030120 | ROTARY SWITCH PHONO    |
| RF01 | RK01030630 | VARIABLE 10KΩ TONE     |
| RF02 | RK01030630 | VARIABLE 10KΩ TONE     |
| RF51 | RK01030630 | VARIABLE 10KΩ TONE     |
| RF52 | RK01030630 | VARIABLE 10KΩ TONE     |
| RG01 | RM05031210 | VARIABLE 50KΩ MASTER   |
| RS05 | RM01040890 | VARIABLE 100KΩ BALANCE |

- |      |            |                         |
|------|------------|-------------------------|
| SS01 | SP04020470 | PUSH SWITCH SUBSONIC    |
| SS02 | SP04010500 | PUSH SWITCH CD DIRECT   |
| ST01 | SP04040360 | PUSH SWITCH TAPE 1, 2   |
| ST02 | SP04010480 | PUSH SWITCH MUTING      |
| ST03 | SP02011490 | PUSH SWITCH TONE DEFECT |
| SD01 | SS04030260 | SLIDE SWITCH            |
| LV01 | LY20240230 | RELAY CD DIRECT         |
| LV02 | LY20240230 | RELAY PHONO DIRECT      |
| SV01 | SS04060050 | SLIDE SWITCH            |
| SV02 | SS06030220 | SLIDE SWITCH            |
| LW01 | SY20240150 | RELAY SPEAKER           |
| LW02 | SY20240150 | RELAY SPEAKER           |
| SC01 | SP02020860 | PUSH SWITCH SPEAKER     |
| R723 |            |                         |
| R728 | RA02230760 | TRIMMING 22KΩ           |

NOTE ON SAFETY :

Symbol  $\Delta$  Fire or electrical shock hazard. Only original parts should be used to replace any part marked with symbol  $\Delta$ . Any other component substitution (other than original type), may increase risk of fire or electrical shock hazard.

Components and wiring are subject to change fo

# Model PM-84II

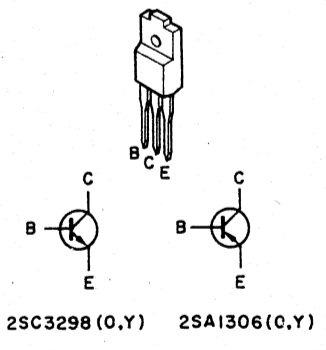
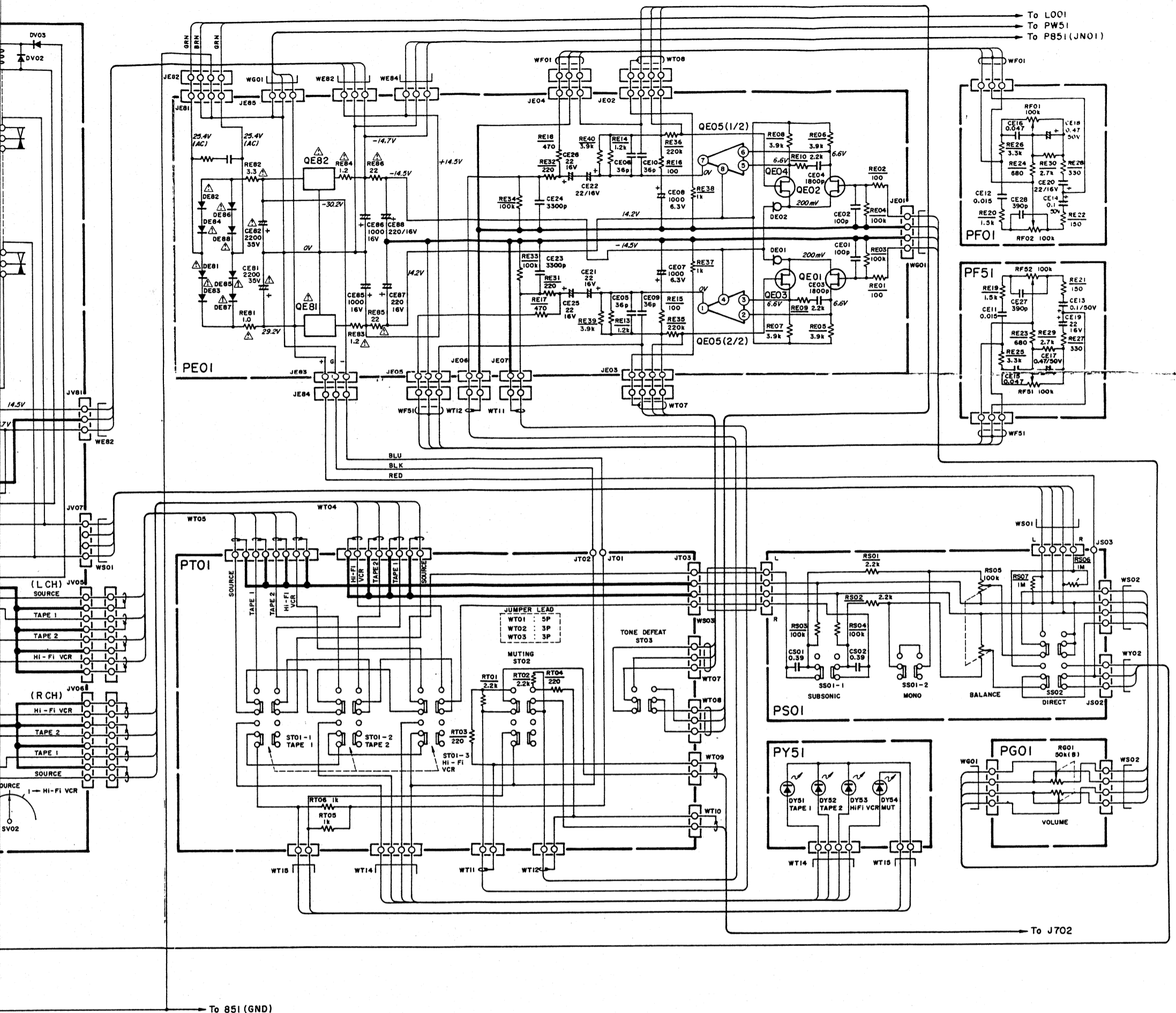

2SA1316 (GR BL)  
2SC3329 (GR BL)

"SERVICE INFORMATION IS FOR USE BY QUALIFIED PERSONNEL ONLY - ANY MISADJUSTMENT OR MISALIGNMENT MAY BE TREATED AS A NON-WARRANTY REPAIR BY ANY MARANTZ SERVICE CENTRE -"

### Kind of Common Parts

- RESISTOR**  
**R\*\*\*** (1) GD05 --- 140, Carbon film fixed resistor, ±5% 1/4W  
**R\*\*\*** (2) GD05 --- 160, Carbon film fixed resistor, ±5% 1/6W  
**C\*\*\*** : CERAMIC CAP.  
 (1) DD1 --- 370, Ceramic condenser, disc type (titan condenser) Temp. coeff. P350 ~ N1000 50V  
**C\*\*\*** : CERAMIC CAP.  
 (1) DK16 --- 300, High dielectric constant ceramic condenser, disc type (titan variable) Temp. chara. 2B4 50V

- C\*\*\*** : ELECTROLYTIC CAP. (≡) / FILM CAP. (≡≡)  
 (1) EA --- 10, Electrolytic condenser, one-way lead type, tolerance ±20%  
 (2) DF15 --- 350, Plastic film condenser, one-way type, Mylar, ±5% 50V

\*In case of ordering the common parts, please establish the correct figure number of 10 figures by the procedure "ASSIGNMENT OF COMMON PARTS CODES"

subject to change for modification without notice.

M7038

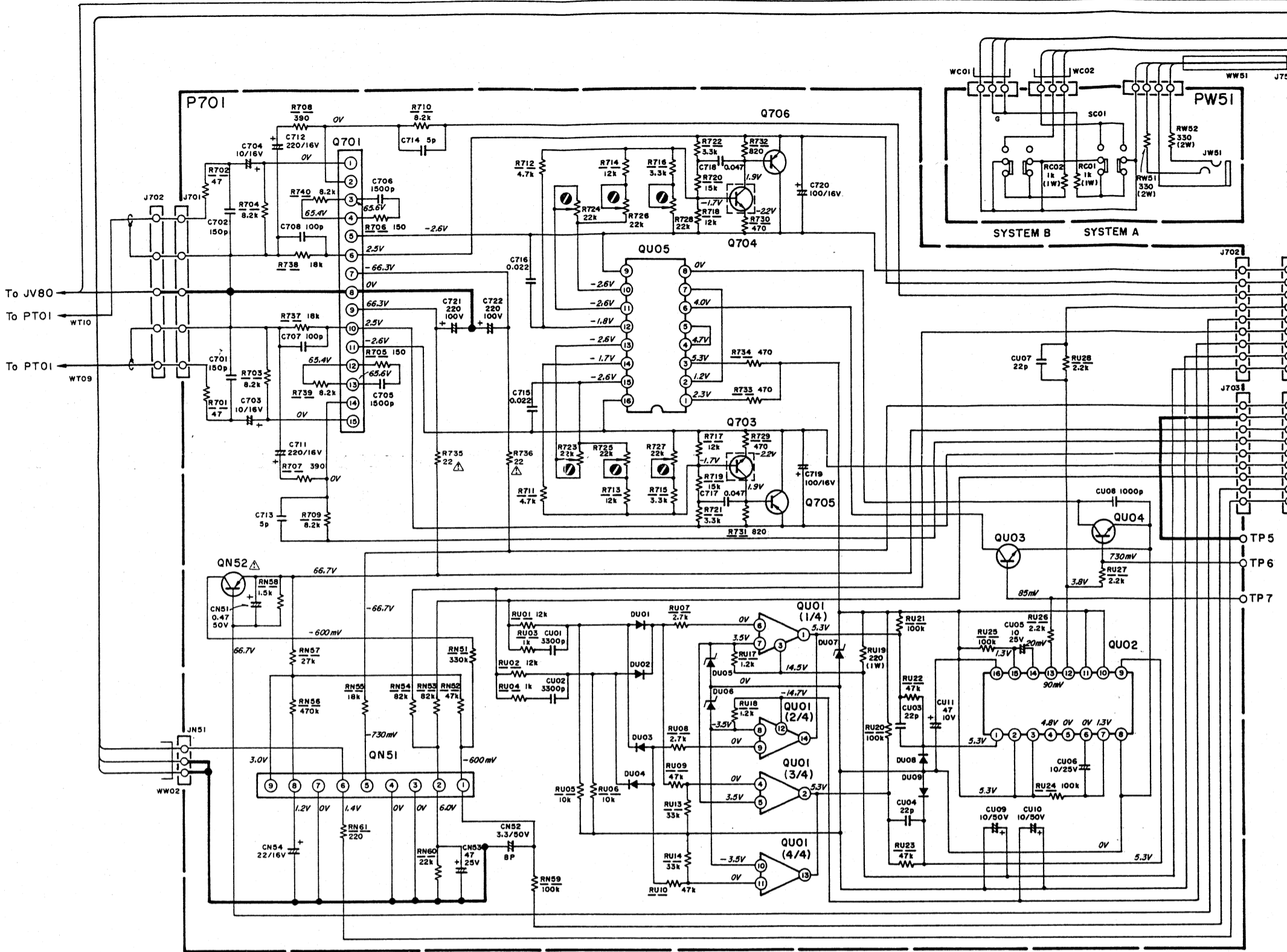

FOR (F) VERSION

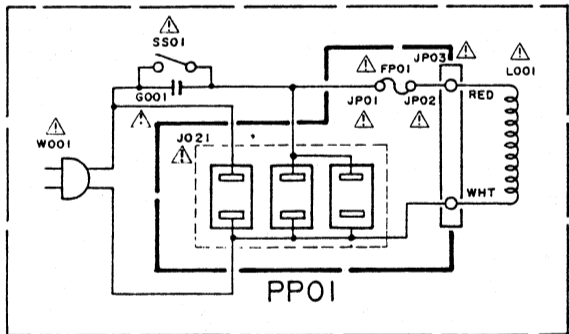

FOR (E) VERSION

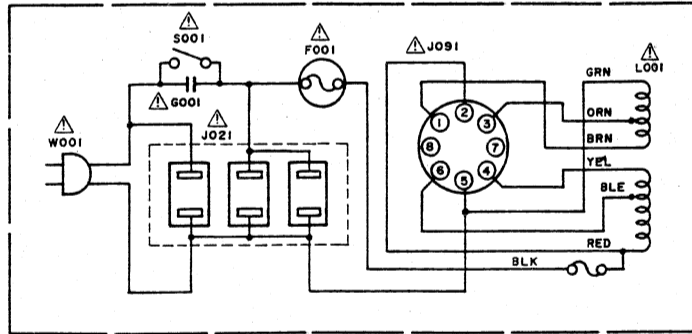

FOR (A,N,T) VERSION

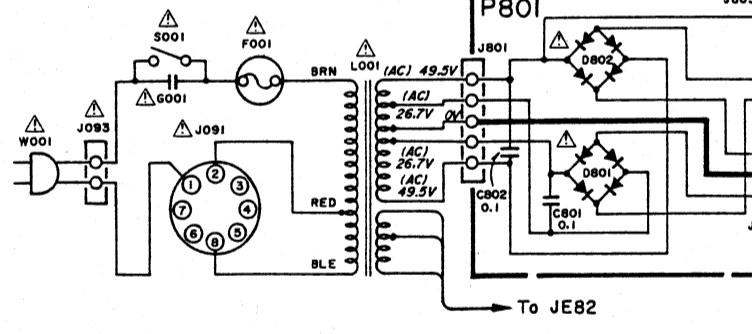

Q701 HC10141030 STK3122 MK3	Q755, Q756 HT326823A0 25C2682P (Q, R)	Q852 HT113863A0 2SA1386 (O, P, Y)	Q855, Q857 QN01, QN02, QN05 HT322402A0 25C2240 (GR, BL)	QN52 HT109701A0 2SA970GR	QU03, QU04 HT327852C0 25C2785 (EF, FF)	D802 HE20013290 D5FB20	D853, D854, D857 HD20022030 25F10C	DU05, DU06 HD30001020 MA1033	QL01, QL02, QL05, HF20405100 25K405
Q703, Q704 HT334191Y0 25C3419Y	Q757, Q758 HT111423A0 25A1142P (Q, R)	Q853 HT332982D0 25C3298 (O, Y)	Q856, Q858, QN03, QN04 HT109702A0 2SA970 (GR, BL)	QU01 HC10009090 NJM2901	QU05 HW10005320 PC847	D851, D852 DU01 ~ DU04, DU08, DU09 DW01, DW02 HD20011050 ISI555	D855, D856 HD20027100 30DF-2	DU07 HD30004020 MA1051	QL03, QL04, QL07, HF10115100 25J115
Q705, Q706 HT110152A0 25A1015 (O, Y)	Q851 HT335193A0 25C3519 (O, P, Y)	Q854 HT113062D0 2SA1306 (O, Y)	QN51 HC10042050 TA7317P	QU02 HC712301A0 74LS123P	D801 HE20009290 S5VB20	DN01 ~ DN08 HD20014010 ISS81			

NOTE ON SAFETY :

Symbol  $\Delta$  Fire or electrical shock hazard. Only original parts should be used to replace any part marked with symbol  $\Delta$ . Any other component substitution (other than original type), may increase risk of fire or electrical shock hazard.

Components and wiring are subject to change for modification without notice.

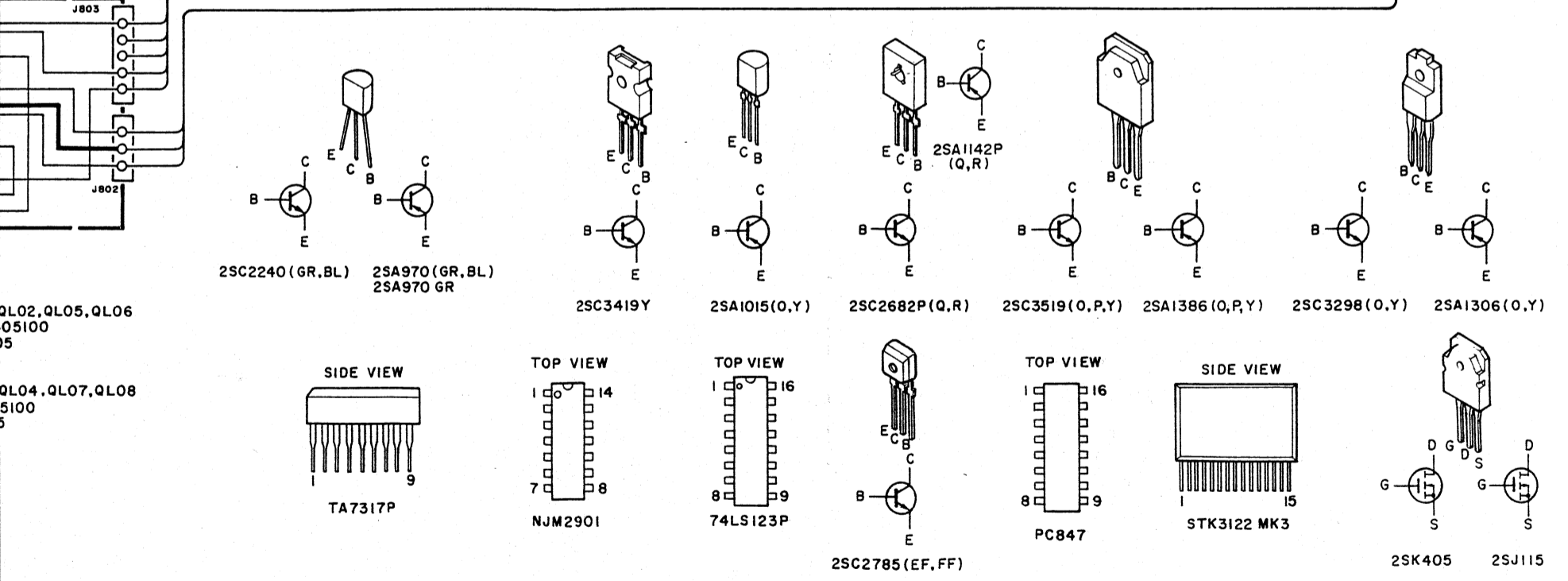
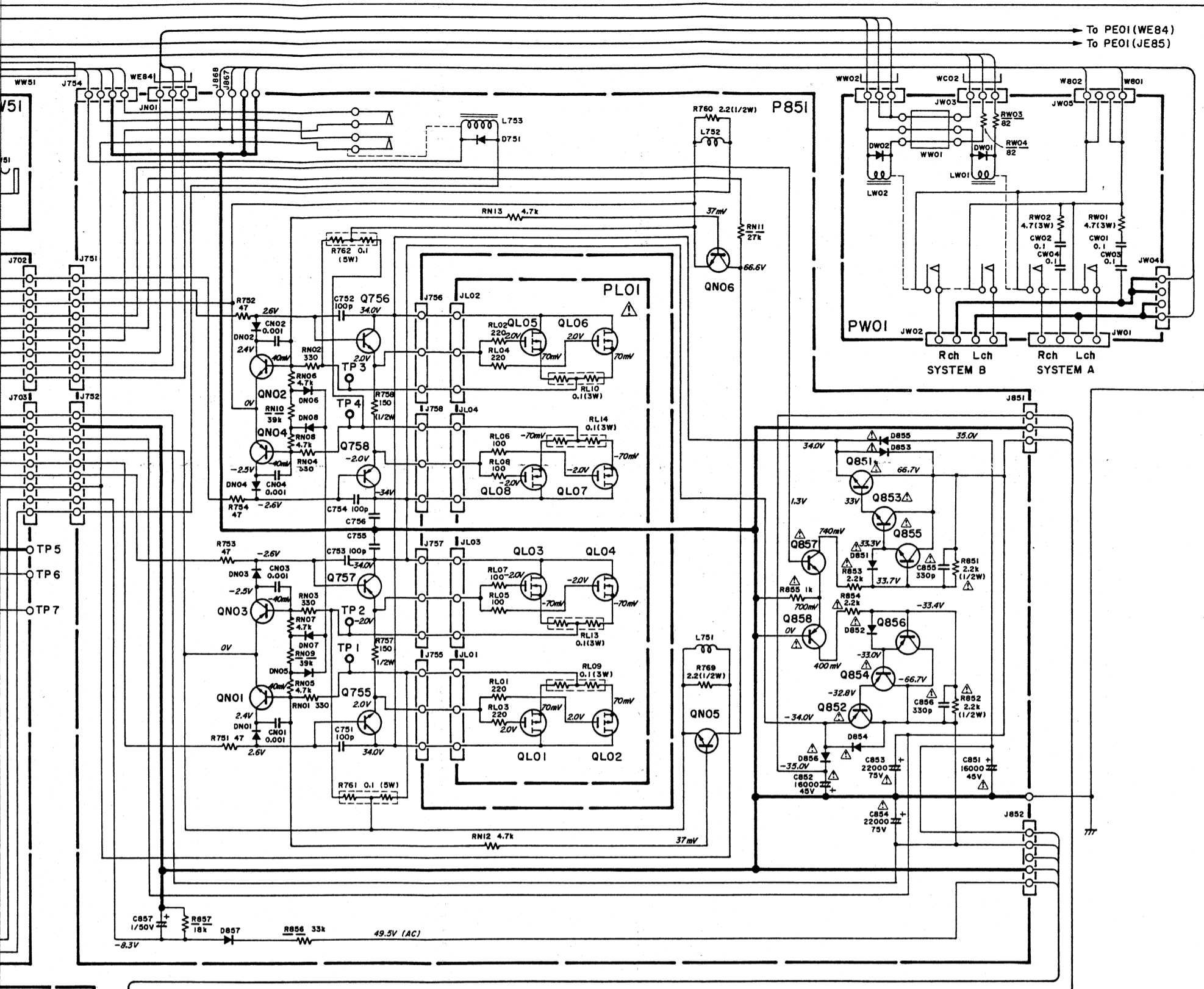

"SERVICE INFORMATION IS FOR USE BY QUALIFIED PERSONNEL ONLY - ANY MISADJUSTMENT OR MISALIGNMENT MAY BE TREATED AS A NON-WARRANTY REPAIR BY ANY MARANTZ SERVICE CENTRE -"

Kind of Common Parts

- RESISTOR**
- R\*\*\* (1) GD05 --- 140, Carbon film fixed resistor, ±5% 1/4W
  - R\*\*\* (2) GD05 --- 160, Carbon film fixed resistor, ±5% 1/6W
- C\*\*\* : CERAMIC CAP.**
- (1) DD1 ---- 370, Ceramic condenser, disc type (titan condenser) Temp. coeff. P350 ~ N1000 50V
- C\*\*\* : CERAMIC CAP.**
- (1) DK16 --- 300, High dielectric constant ceramic condenser, disc type (titan variable) Temp. chara. 2B4 50V

- ELECTROLY CAP. (E) / FILM CAP. (F)**
- (1) EA ----- 10, Electrolytic condenser, one-way lead type, tolerance ±20%
  - (2) DF15 --- 350, Plastic film condenser, one-way type, Mylar, ±5% 50V

\*In case of ordering the common parts, please establish the correct parts number of 10 figures by the procedure "ASSIGNMENT OF COMMON PARTS CODES"