

Service Manual

PMD330 /N1M, /U1B, /F1B
PMD331 /N1M, /U1B, /F1B
PMD340 /N1M, /U1B, /F1M
CD Player

PMD330/331/340

PMD330

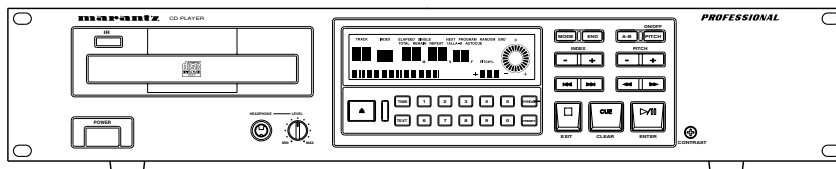

PMD331 / 340

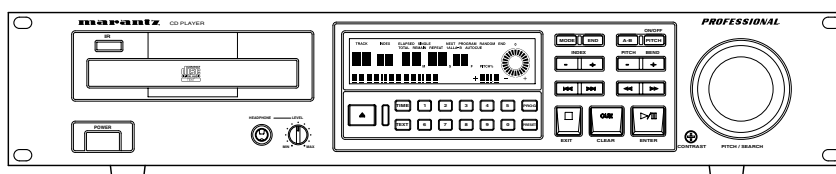

TABLE OF CONTENTS

SECTION	PAGE
1. TECHNICAL SPECIFICATIONS	1
2. SERVICE HINTS	2
3. SERVICE TOOLS	2
4. ADJUSTMENT AND SERVICE MODE	3
5. MICROPROCESSOR AND IC DATA	5
6. WIRING DIAGRAM	13
7. BLOCK DIAGRAM	15
8. SCHEMATIC DIAGRAM	17
9. PARTS LOCATIONS	24
10. EXPLODED VIEW AND MECHANISM PARTS LIST	28
11. TECHNICAL DESCRIPTION	31
12. ELECTRICAL PARTS LIST	33

Please use this service manual with referring to the user guide (D.F.U.) without fail.

修理の際は、必ず取扱説明書を準備し操作方法を確認の上作業を行ってください。

marantz®

PMD330 / 331 / 340

371K855010 MIT
3120 785 22250
First Issue 1999.12

MARANTZ DESIGN AND SERVICE

Using superior design and selected high grade components, **MARANTZ** company has created the ultimate in stereo sound. Only original **MARANTZ** parts can insure that your **MARANTZ** product will continue to perform to the specifications for which it is famous.

Parts for your **MARANTZ** equipment are generally available to our National Marantz Subsidiary or Agent.

ORDERING PARTS :

Parts can be ordered either by mail or by Fax.. In both cases, the correct part number has to be specified.

The following information must be supplied to eliminate delays in processing your order :

1. Complete address
2. Complete part numbers and quantities required
3. Description of parts
4. Model number for which part is required
5. Way of shipment
6. Signature : any order form or Fax. must be signed, otherwise such part order will be considered as null and void.

USA

MARANTZ AMERICA, INC.
440 MEDINAH ROAD
ROSELLE, ILLINOIS 60172
USA
PHONE : 630 - 307 - 3100
FAX : 630 - 307 - 2687

EUROPE / TRADING

MARANTZ EUROPE B.V.
P.O.BOX 80002, BUILDING SFF2
5600 JB EINDHOVEN
THE NETHERLANDS
PHONE : +31 - 40 - 2732241
FAX : +31 - 40 - 2735578

BRAZIL

PHILIP DA AMAZONIA IND. ELET. ITDA
CENTRO DE INFORMACOES AO
CEP 04698-970
SAO PAULO, SP, BRAZIL
PHONE : 0800 - 123123(Discagem Direta Gratuita)
FAX : +55 11 534. 8988

PROFESSIONAL AMERICAS

SUPERSCOPE TECHNOLOGIES, INC.
MARANTZ PROFESSIONAL PRODUCTS
2640 WHITE OAK CIRCLE, SUITE A
AURORA, ILLINOIS 60504 USA
PHONE : 630 - 820 - 4800
FAX : 630 - 820 - 8103

PROFESSIONAL AUSTRALIA

TECHNICAL AUDIO GROUP PTY, LTD
558 DARLING STREET,
BALMAIN, NSW 2041,
AUSTRALIA
PHONE : 61 - 2 - 9810 - 5300
FAX : 61 - 2 - 9810 - 5355

CANADA

LENBROOK INDUSTRIES LIMITED
633 GRANITE COURT,
PICKERING, ONTARIO L1W 3K1
CANADA
PHONE : 905 - 831 - 6333
FAX : 905 - 831 - 6936

AUSTRALIA

JAMO AUSTRALIA PTY LTD
1 EXPO COURT, P.O. BOX 350
MT. WAVERLEY VIC 3149
AUSTRALIA
PHONE : +61 - 3 - 9543 - 1522
FAX : +61 - 3 - 9543 - 3677

THAILAND

MRZ STANDARD CO.,LTD
746 - 754 MAHACHAI ROAD.,
WANGBURAPAPIROM, PHRANAKORN,
BANGKOK, 10200 THAILAND
PHONE : +66 - 2 - 222 9181
FAX : +66 - 2 - 224 6795

SINGAPORE

WO KEE HONG (S) PTE LTD
WO KEE HONG CENTRE
NO.23, LORONG 8, TOA PAYOH
SINGAPORE 319257
PHONE : +65 2544555
FAX : +65 2502213

NEW ZEALAND

WILDASH AUDIO SYSTEMS NZ
14 MALVERN ROAD MT ALBERT
AUCKLAND NEW ZEALAND
PHONE : +64 - 9 - 8451958
FAX : +64 - 9 - 8463554

TAIWAN

PAI- YUING CO., LTD.
6 TH FL NO, 148 SUNG KIANG ROAD,
TAIPEI, 10429, TAIWAN R.O.C.
PHONE : +886 - 2 - 25221304
FAX : +886 - 2 - 25630415

MALAYSIA

WO KEE HONG ELECTRONICS SDN. BHD.
SUITE 8.1, LEVEL 8, MENARA GENESIS,
NO. 33, JALAN SULTAN ISMAIL,
50250 KUALA LUMPUR, MALAYSIA
PHONE : +60 3 - 2457677
FAX : +60 3 - 2458180

JAPAN *Technical*

MARANTZ JAPAN, INC.
35- 1, 7- CHOME, SAGAMIONO
SAGAMIHARA - SHI, KANAGAWA
JAPAN 228-8505
PHONE : +81 42 748 1013
FAX : +81 42 741 9190

日本マランツ株式会社

本社 〒228-8505
神奈川県相模原市相模大野7-35-1
営業本部 〒150-0022
東京都渋谷区恵比寿南1-11-9

KOREA

MK ENTERPRISES LTD.
ROOM 604/605, ELECTRO-OFFICETEL, 16-58,
3GA, HANGANG-RO, YONGSAN-KU, SEOUL
KOREA
PHONE : +822 - 3232 - 155
FAX : +822 - 3232 - 154

SHOCK, FIRE HAZARD SERVICE TEST :

CAUTION : After servicing this appliance and prior to returning to customer, measure the resistance between either primary AC cord connector pins (with unit NOT connected to AC mains and its Power switch ON), and the face or Front Panel of product and controls and chassis bottom.

Any resistance measurement less than 1 Megohms should cause unit to be repaired or corrected before AC power is applied, and verified before it is return to the user/customer.

Ref. UL Standard No. 813.

In case of difficulties, do not hesitate to contact the Technical Department at above mentioned address.

1. TECHNICAL SPECIFICATIONS

		PMD330	PMD331 / PMD340
General specifications			
System	Compact Disc - Digital Audio		
Number of channels	2		
Compatible discs	CD-DA, CD-R, CD-RW (12 cm, 8 cm)		
Audio characteristics			
Channels	2 channels		
Frequency characteristics	20 Hz to 20 kHz +/- 0.3 dB		
Dynamic range	≥ 90 dB (1 kHz)		
S/N ratio	≥ 100 dB (1 kHz)		
Total harmonic distortion (THD)	0.005 % (1 kHz)		
Wow and flutter	Quartz precision		
Error correction method	Cross-interleave Read-Solomon code (CIRC)		
Analog output	Pin jack, unbalanced (RCA)	2.0V RMS Stereo	
	XLR jack, balanced (XLR) (variable range)	—	+16 dBu /600 Ω, @ 0 dB FS (-11 dBu to +21 dBu, variable)
Digital output	Pin jack (SPDIF)	0.5 Vp-p/75 Ω	
	XLR jack (SPDIF)	—	3.5 Vp-p/110 Ω
	optical connector	—	-19 dBm
Search precision	1 frame		
Pitch control	Maximum: +/-12% in 0.1% steps		
Pitch bend control	—	+/- 8 %	
Strat timing	—	20 ms	
Remote control			
Infrared remote control input	IN (IR sensor)		
RC5 remote control input/output	— RCA IN (INT/EXT switch)/OUT		
Remote control input/output	— D-SUB 25-Pin female		
Optical anning method			
Laser	AlGaAs semiconductor		
Wavelength	780 nm		
Signal system			
Sampling frequency	44.1 kHz		
Quantization	16-bit linear/channel		
Power supply section			
AC power supply	/F : 100V, AC 50/60Hz, /N : 230V, AC 50Hz, /U : 120V, AC 60Hz		
Power consumption	12 W	17 W	
Cabinet, etc.			
External dimensions (W x H x D)	483 x 100 x 325 mm (19 x 3-15/16 x 12- 13/16 inches)		
Weight	4.8 kg (10.6 lbs)	4.9 kg (10.8 lbs)	
Operating temperature range	+ 5°C to + 35°C		
Operating humidity range	5% to 90% (without dew)		

Due to our continuing efforts to improve our products, the specifications and appearance of this product are subject to change without prior notice.

2. SERVICE HINTS

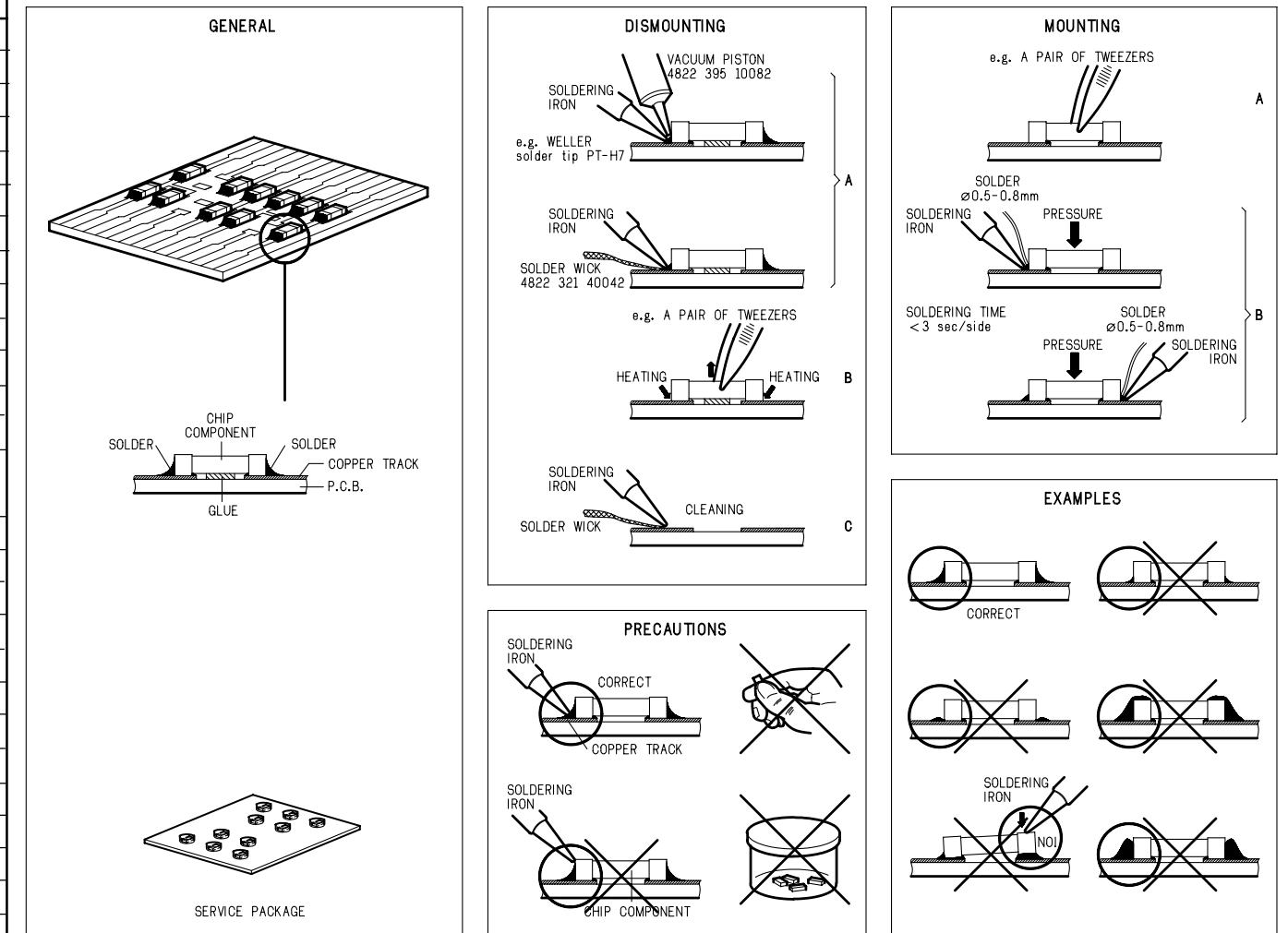

3. SERVICE TOOLS

Audio signals disc	4822 397 30184
Disc without errors (SBC444)+	
Disc with DO errors, black spots and fingerprints (SBC444A)	4822 397 30245
Disc (65 min 1kHz) without no pause	4822 397 30155
Max. diameter disc (58.0 mm)	4822 397 60141
Torx screwdrivers	
Set (straight)	4822 395 50145
Set (square)	4822 395 50132
13th order filter	4822 395 30204

4. ADJUSTMENT AND SERVICE MODE

1.1. Digital Output (Coaxial) Check

On the preset menu, set "D.OUT" to "ON".(PMD331/PMD340)
Do waveform observation with the oscilloscope, and confirm the digital output level of JT01 to be 0.5Vp-p, square wave within ±20% .

1.2. Balanced Output Adjustment (PMD331/PMD340)

1kHz, 0 dB are played back by using TEST disc.
Turn RB01 on the rear panel, and adjust the output of JB53 (Balanced Out L-Ch).
Turn RB02 on the rear panel, and adjust the output of JB54 (Balanced Out R-Ch).
Adjust each output level to 16 dBu, within ±0.5dB.

1.3. Service Mode

- 1) With power off, simultaneously press the PLAY/PAUSE, MODE and TIME buttons, and at the same time, press the power button. At this time the LCD shows the model name and firmware version.
- 2) Next, press CUE button.
- 3) At this time the LCD shows " Test : Version ". (TEST MODE select menu)
- 4) The NEXT and PREVIOUS buttons change the TEST MODE(refer to the chart below). The PLAY button selects it.
- 5) Pressing the CUE button returns to the TEST MODE select menu.
- 6) Press the STOP button to exit the service mode.

INDEX	TEST MODE	CONTENTS
1.3.1	Version	MPU firmware version check
1.3.2	Display	LCD&LED test
1.3.3	Key&GPI	Confirmation of Buttons, GPI Control I/O and RC5
1.3.4 *	EE-PROM	Check of EEPROM Read/Write
1.3.5 *	Pickup	Manual moving of the pickup

* It is not usually necessary to confirm.

1.3.1. Model name and firmware version check

When the LCD shows "Test : Version", press the PLAY button, to see the model name and the MPU firmware version.
Pressing the CUE button returns to the TEST MODE select menu.

1.3.2. LCD and LED test

- 1) Set the LCD panel contrast adjustment screw to mechanical center. (you will feel a click.)
- 2) When the LCD shows "Test : Display", press the PLAY button.
- 3) The LCD and LED lights as the chart below.
- 4) Each time the PLAY/PAUSE button is pressed the LCD and LED change as shown in the chart below.
- 5) Pressing the CUE button returns to the TEST MODE select menu.

	LCD	BUTTON				GPI Control I/O					
		END	PITCH	PLAY	CUE	PLAY TALLY	PAUSE TALLY	CUE TALLY	FADER TALLY	INDEX	END TALLY
①	PATTERN 1	○	×	○	×	○	×	○	×	○	×
②	PATTERN 2	×	○	×	○	×	○	×	○	×	○
③	All light up	○	○	○	○	○	○	○	○	○	○
④	None light up	×	×	×	×	×	×	×	×	×	×

○ : Light X : Not Light

4. 調整とサービスモード

1.1. Digital Output (Coax) 確認

Preset Menuで "D.OUT" を "ON" に設定する。(PMD331/PMD340)
JT01のデジタル出力レベルをオシロスコープで波形観測をおこない 0.5Vp-p, +/-20%以内の矩形波である事を確認する。

1.2. Balanced Output 調整 (PMD331/PMD340)

TEST Disc を使用し 1kHz, 0dB を再生する。
背面パネルのRB01を回して JB53 (Balanced Out L-Ch)の出力を調整する。
背面パネルのRB02を回して JB54 (Balanced Out R-Ch)の出力を調整する。
各々の出力レベルを 16dBu, +/-0.5dB 以内に調整する。

1.3. SERVICE モードでの確認

電源OFFの状態、Play/Pause ボタン、Modeボタン、Time ボタンを同時に押しながら電源を入れる。
または電源ONの状態、赤外線リモコンからサービスコードを送ることにより、サービスモードに入る。この時、LCDにはモデル名とMPUファームウェアのバージョン表示される。
次に、CUEボタンを押す。
この時、LCDの表示が " Test : Version " となる。(Test mode 選択画面)
NextとPrevious ボタンで Test mode(下表参照)を切り替え、Play ボタンで選択する。
CUEボタンで Test mode 選択画面の状態に戻る。
Stopボタンでサービスモードを終了する。

確認項目	Test mode	内容
1.3.1	Version	MPU のファームウェアのバージョン表示
1.3.2	Display	LCD&LED 表示点灯テスト
1.3.3	Key&GPI	ボタン、GPI Control I/O、RC5 の入力表示
1.3.4 *	EE-PROM	EEPROM Read/Write のチェック
1.3.5 *	Pickup	ピックアップを手動で動作させる

* 印の項目は通常確認の必要は無い。

1.3.1. モデル名/プログラムバージョンの確認

"Test : Version" と表示されているときに、Play ボタン押すと、モデル名とMPUファームウェアのバージョンが表示される。
CUEボタンを押すと Test mode 選択画面 の状態に戻ります。

1.3.2. LCD 表示 & LED点灯の確認

あらかじめ前面パネルのコントラスト調整用ボリューム RY01 をメカニカルセンターでクリックする位置に調整する。
"Test : Display " と表示されているときに、Play ボタン押すと、下記表に従ってLCDとLEDが点灯される。 Play ボタンを押す毎にLCDとLEDは下表の順に表示・点灯が切り替わる。
CUEボタンを押すと Test mode 選択画面 の状態に戻ります。

PATTERN 1

-パターン1表示

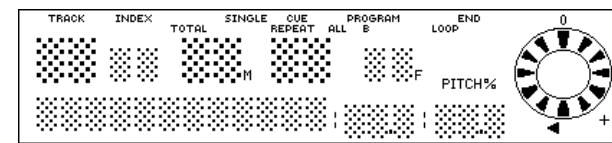

PATTERN 2

-パターン2表示

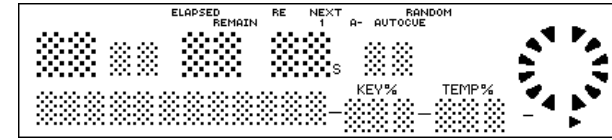

1.3.3. Confirmation of Buttons, GPI Control I/O and RC5

- 1) When the LCD shows "Test : Key&GPI", press the PLAY button.
- 2) The LCD shows "No Signal".
- 3) Press a button, GPI Control I/O and RC5 are input, and the LCD changes as shown in the chart below.

FUNCTION	SW Input	GPI * Input	RC5 Input	FUNCTION	SW Input	GPI * Input	RC5 Input
Open/Close	28	--	29	Preset	33	--	34
Time	29	--	30	Index +	17	8	18
CD-Text	30	--	31	Index -	18	9	19
Mode	31	--	32	0	1	--	2
Stop ***	--	--	--	1	2	--	3
Cue ****	--	--	--	2	3	--	4
Play/Pause	11	--	--	3	4	--	5
Play	--	1	12	4	5	--	6
Cue + Play	13	4	--	5	6	--	7
Pause	--	2	13	6	7	--	8
Next	15	10	16	7	8	--	9
Previous	16	11	17	8	9	--	10
FF	19	6	20	9	10	--	11
REW	20	7	21	Pitch Bend +*	26	--	27
END	22	--	23	Pitch Bend -*	27	--	28
A-B Repeat	21	--	22	Service	--	--	35
Pitch +	24 **	13	25	Fader (Normal)	--	Fader Input	--
Pitch -	25 **	14	26	Program	32	--	33
Program	32	--	33	Pitch On/Off	23	15	24
Pitch On/Off	23	15	24	Fader (Invert)	--	Fader Input	--

* : PMD331, PMD340 only. ** : PMD330 only.

*** : The service mode is exited.

**** : The TEST MODE select menu is returned.

1.3.4. Check of EEPROM Read/Write

- 1) When the LCD shows "Test : EE-PROM", press the PLAY button.
- 2) Check of EEPROM Read/Write begins. The check takes about 1 minute. During the check pressing any button has no effect.
- 3) At this time the LCD shows as the following order.
"ADDR (LOW)"--->"WRITE (LOW)"--->"WRITE (HIGH)"
--->"PAGE WRITE"--->"EEPROM OK!"
- 4) If there is an error in the EEPROM, the LCD shows "EEPROM NG!".
- 5) Pressing the CUE button returns to the TEST MODE select menu.

1.3.5. Manual moving of Pick up

- 1) When the LCD shows "Test : Pickup", press the PLAY button.
- 2) The LCD shows "Laser power". The laser diode turns on.
- 3) Press the NEXT button. The sled will move to the outside.
- 4) Press the PREVIOUS button. The sled will move to the inside.
- 5) Pressing the CUE button returns to the TEST MODE select menu.

1.3.3. ボタン、GPI Control I/O、RC5の確認

"Test : Key&GPI" と表示されているときに、Play ボタン押すと "No Signal" と表示が変わり入力された信号源と種類を下記の表に従いLCDに表示する。

* : PMD331, PMD340 のみ。

** : PMD330 のみ。

*** : サービスモードが終了する。

**** : Test mode 選択画面 の状態に戻ります。

1.3.4. EEPROMのRead/Writeチェック

"Test : EE-PROM" と表示されているときに、Play ボタン押すとEEPROMのRead/Write チェックを始めます。チェックに要する時間は約1分間です。
チェック中は一切のボタン操作が無効となります。
この時LCDには "ADDR (LOW)" --> "WRITE (LOW)" --> WRITE (HIGH) --> "PAGE WRITE" --> "EEPROM OK!" のように表示されます。
EEPROMに不具合がある場合は、"EEPROM NG!" が表示されます。
CUEボタンを押すと Test mode 選択画面 の状態に戻ります。

1.3.5. Pickup の手動移動

"Test : Pickup" と表示されているときに、Play ボタン押すと "Laser power" と表示が変わり Laser Diode がONします。
Next ボタンで外周へ、Previous ボタンで内周へスレッドが移動します。
CUEボタンを押すと Test mode 選択画面 の状態に戻ります。

○→点灯、×→消灯

QD01 : CXD2585Q

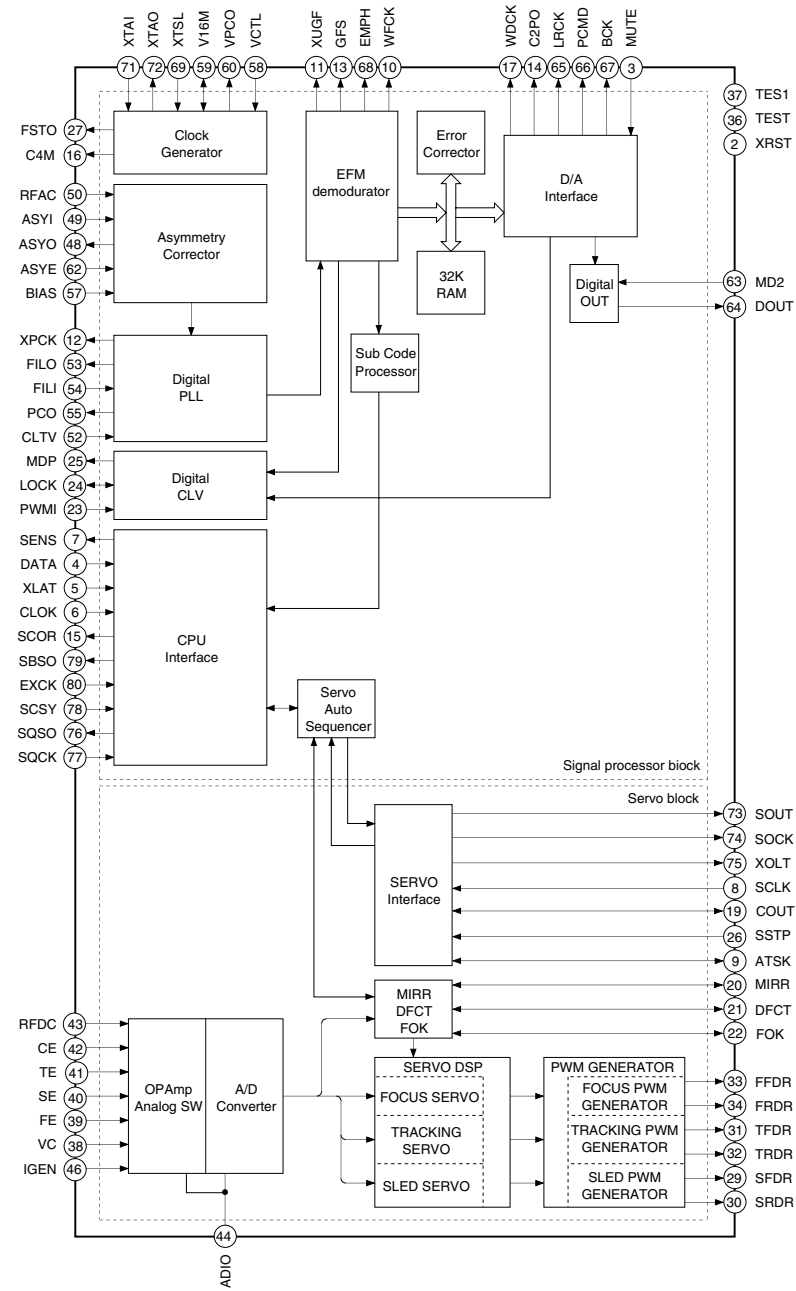

Pin No.	Symbol	I/O	Description
1	DVDD0	-	Power supply.
2	XRST	I	System reset. Reset when low.
3	MUTE	I	Mute input (low: off, high: on)
4	DATA	I	Serial data input from CPU.
5	XLAT	I	Latch input from CPU. Serial data is latched at the falling edge.
6	CLOCK	I	Serial data transfer clock input from CPU.
7	SENS	O 1, 0	SENS output to CPU.
8	SCLK	I	SENS serial data readout clock input.
9	ATSK	I/O 1, 0	Anti-shock input/output.
10	WFCK	O 1, 0	WFCK output.
11	XUGF	O 1, 0	XUGF output. MNT0 or RFCK is output by switching with the command.
12	XPCK	O 1, 0	XPCK output. MNT1 is output by switching with the command.
13	GFS	O 1, 0	GFS output. MNT2 or XROF is output by switching with the command.
14	C2PO	O 1, 0	C2PO output. MNT3 or GTOP is output by switching with the command.
15	SCOR	O 1, 0	Outputs a high signal when either subcode sync SO or S1 is detected.
16	C4M	O 1, 0	4.2336MHz output. 1/4 frequency division output for V16M in CAV-W mode or variable pitch mode.
17	WDCK	O 1, 0	Word clock output. f = 2Fs. GRSCOR is output by the command switching.
18	DVss0	-	Digital GND.
19	COUT	I/O 1, 0	Track count ,signal I/O.
20	MIRR	I/O 1, 0	Mirror signal I/O.
21	DFCT	I/O 1, 0	Detect signal I/O.
22	FOK	I/O 1, 0	Focus OK signal I/O.
23	PWMI	I	Spindle motor external control input.
24	LOCK	I/O 1, 0	GFS is sampled at 460Hz; when GFS is high, this pin outputs a high signal. If GFS is low eight consecutive samples, this pin outputs low. Input when LKIN=1.
25	MDP	O 1, Z, 0	Spindle motor servo control output.
26	SSTP	I	Disc innermost track detection signal input.
27	FSTO	O 1, 0	2/3 frequency division output for XTAI pin.
28	DVDD1	-	Digital power supply.
29	SFDR	O 1, 0	Sled drive output.
30	SRDR	O 1, 0	Sled drive output.
31	TFDR	O 1, 0	Tracking drive output.
32	TRDR	O 1, 0	Tracking drive output.
33	FFDR	O 1, 0	Focus drive output.
34	FRDR	O 1, 0	Focus drive output.
35	DVss1	-	Digital GND.
36	TEST	I	Test. Normally, GND.

Pin NO.	Symbol	I/O	Description
37	TES1	I	Test. Normally, GND.
38	VC	I	Center voltage input.
39	FE	I	Focus error signal input.
40	SE	I	Sled error signal input.
41	TE	I	Tracking error signal input.
42	CE	I	Center servo analog input.
43	RFDC	I	RF signal input.
44	ADIO	O Analog	Test. No connected.
45	AVss0	-	Analog GND.
46	IGEN	I	Constant current input for operational amplifier.
47	AVDD0		Analog power supply.
48	ASYO	O 1, 0	EFM full-swing output. (low = Vss, high = VDD)
49	ASYI	I	Asymmetry comparator voltage input.
50	RFAC	I	EFM signal input.
51	AVss1	-	Analog GND.
52	CLTV	I	Multiplier VCO1 control voltage input.
53	FILO	O Analog	Master PLL filter output (slave = digital PLL).
54	FILI	I	Master PLL filter input.
55	PCO	O 1, Z, 0	Master PLL charge pump output.
56	AVDD1	-	Analog power supply.
57	BIAS	I	Asymmetry circuit constant current input.
58	VCTL	I	Wide-band EFM PLL VC02 control voltage input.
59	V16M	I/O 1, 0	Wide-band EFM PLL VC02 oscillation output. Serves as wide-band EFM PLL clock input by switching with the command.
60	VPCO	O 1, Z, 0	Wide-band EFM PLL charge pump output.
61	DVDD2	-	Digital power supply.
62	ASYE	I	Asymmetry circuit on/off (low = oft, high = on).
63	MD2	I	Digital Out on/off control (low = off, high = on).
64	DOUT	O 1, 0	Digital Out output.
65	LRCK	O 1, 0	D/A interface. LR clock output. f = Fs
66	PCMD	O 1, 0	D/A interface. Serial data output (two's complement, MSB first).
67	BCK	O 1, 0	D/A interface. Bit clock output.
68	EMPH	O 1, 0	Outputs a high signal when the playback disc has emphasis, and a low signal when there is no emphasis.
69	XTSL	I	Crystal selection input. Low when the crystal is 16.9344MHZ; high when it is 33.8688MHZ.
70	DVss2	-	Digital GND.
71	XTAI	I	Crystal oscillation circuit input. When the master clock is input externally, input it from this pin.
72	XTAO	O	Crystal oscillation circuit output.

QT52 : SN75158

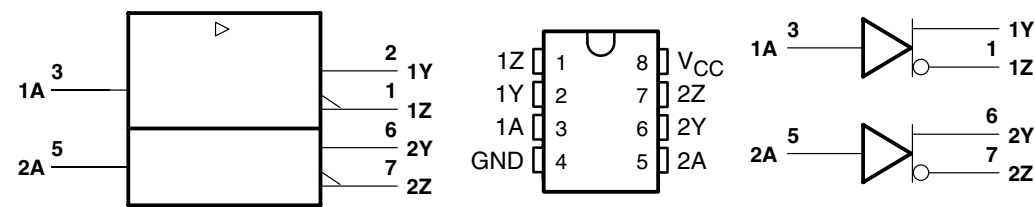

Pin NO.	Symbol	I/O	Description
73	SOUT	O 1, 0	Serial data output in servo block.
74	SOCK	O 1, 0	Serial data readout clock output in servo block.
75	XOLT	O 1, 0	Serial data latch output in servo block.
76	SQSO	O 1, 0	Sub-Q 80-bit, PCM peak or level data outputs. CD TEXT data output.
77	SQCK	I	SQSO readout clock input.
78	SCSY	I	GRSCOR resynchronization input.
79	SBSO	O 1, 0	Sub-Q P to W serial output.
80	EXCK	I	SBSO readout clock input.

- Notes)
- * PCMD is a MSB first, two's complement output.
 - * GTOP is used to monitor the frame sync protection status. (High: sync protection window released.)
 - * XUGF is the frame sync obtained from the EFM signal, and is negative pulse. It is the signal before sync protection.
 - * XPCK is the inverse of the EFM PLL clock. The PLL is designed so that the falling edge and the EFM signal transition point coincide.
 - * The GFS signal goes high when the frame sync and the insertion protection timing match.
 - * RFCK is derived from the crystal accuracy, and has a cycle of 136us. (during normal speed)
 - * C2PO represents the data error status.
 - * XROF is generated when the 32K RAM exceeds the +-28F jitter margin.

Q501 : PCM1710

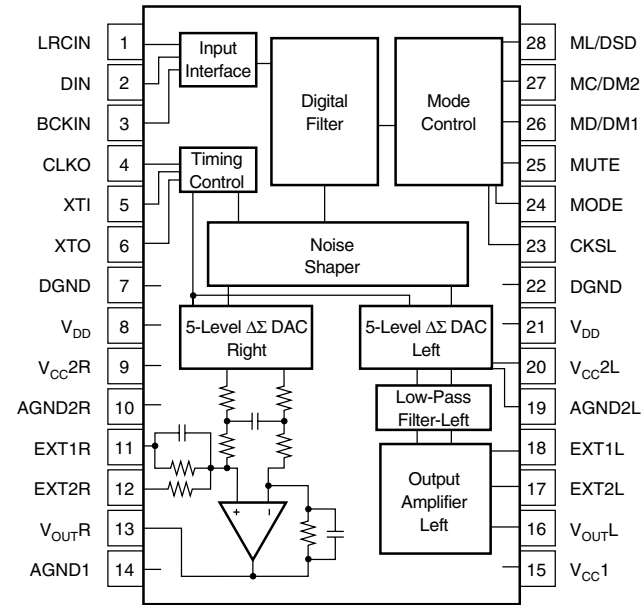

PIN NAME	NUMBER	FUNCTION
Input Interface Pins		
LRCIN	1	Sample Rate Clock Input. Controls the update rate (fs).
DIN	2	Serial Data Input. MSB first, right justified format contains a frame of 16-bit or 20-bit data.
BCKIN	3	Bit Clock Input. Clocks in the data present on DIN input.
Mode Controls and Clock Signals		
CLKO	4	Buffered Output of Oscillator. Equivalent to fs.
XTI	5	Oscillator Input (External Clock Input). For an internal clock, tie XTI to one side of the crystal oscillator. For an external clock, tie XTI to the output of the chosen external clock.
XTO	6	Oscillator Output. When using the internal clock, tie to the opposite side (from pin 5) of the crystal oscillator. When using an external clock, leave XTO open.
CKSL	23	System Clock Select. For 384fs, tie CKSL "High". For 256fs, tie CKSL "Low".
MODE	24	Operation Mode Select. For serial mode, tie MODE "High". For parallel mode, tie MODE "Low".
MUTE	25	Mute Control. To disable soft mute, tie MUTE "High". To enable soft mute, tie MUTE "Low".
MD/DM1	26	Mode Control for Data/De-emphasis. See "Mode Control Functions" on page 11.
MC/DM2	27	Mode Control for BCKIN/De-emphasis. See "Mode Control Functions" on page 11.
ML/DSD	28	Mode Control for WDCK/Double speed dubbing. See "Mode Control Functions" on page 11.
Analog Functions		
V _{OUTR}	13	Right Channel Analog Output.
V _{OUTL}	16	Left Channel Analog Output.
Power Supply Connections		
DGND	7, 22	Digital Ground.
V _{DD}	8, 21	Digital Power Supply (+5V).
V _{CC2R}	9	Analog Power Supply (+5V), Right Channel DAC.
AGND2R	10	Analog Ground (DAC), Right Channel.
EXT1R	11	Output Amplifier Common, Right Channel. Bypass to ground with a 10μF capacitor.
EXT2R	12	Output Amplifier Bias, Right Channel. Connect to EXT1R.
AGND	14	Analog Ground.
V _{CC}	15	Analog Power Supply (+5V).
EXT2L	17	Output Amplifier Bias, Left Channel. Connect to EXT1L.
EXT1L	18	Output Amplifier Common, Left Channel. Bypass to ground with a 10μF capacitor.
AGND2L	19	Analog Ground (DAC), Left Channel.
V _{CC2L}	20	Analog Power Supply (+5V), Left Channel DAC.

Q101 : TZA1022

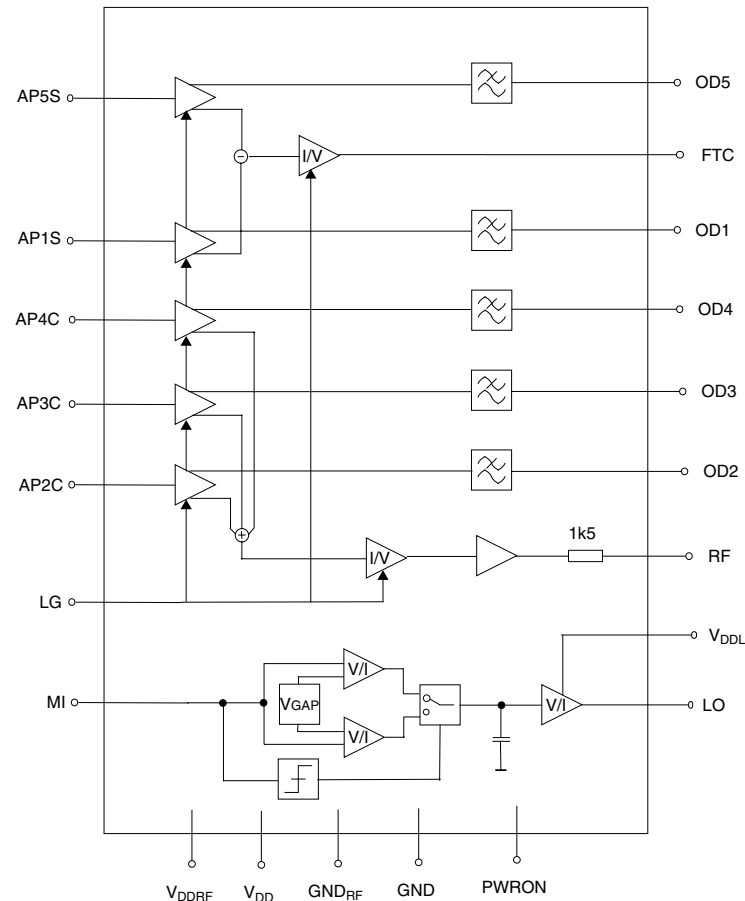

SYMBOL	PIN	DESCRIPTION
OD2	1	output photo diode amplifier 2
OD3	2	output photo diode amplifier 3
OD4	3	output photo diode amplifier 4
OD5	4	output photo diode amplifier 5
OD1	5	output photo diode amplifier 1
PWRON	6	power on switch
RF	7	output data signal
V _{DDRF}	8	RF amplifier supply voltage
V _{DD}	9	supply voltage
GND	10	ground
GND _{RF}	11	ground RF amplifier
V _{DDL}	12	laser supply voltage
LO	13	current output for the laser diode
MI	14	Monitor input
n.c.	15	not connected
n.c.	16	not connected
AP1S	17	Input photo diode amplifier (satellite)
AP2C	18	Input photo diode amplifier (central)
n.c.	19	not connected
FTC	20	output fast track counting
LG	21	CD/CDRW gain switch
AP3C	22	Input photo diode amplifier (central)
AP5S	23	Input photo diode amplifier (satellite)
AP4C	24	Input photo diode amplifier (central)

Q251 : BA6856FP

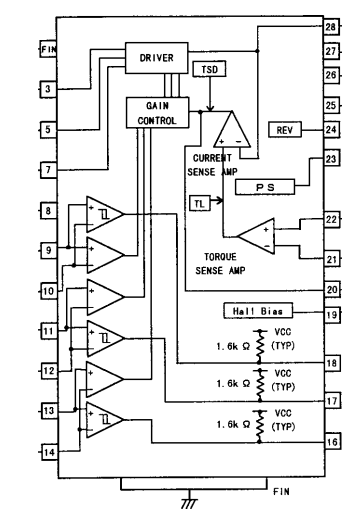

PIN No	端子名 /Pin Name	機能 /Function
1	N.C.	N.C.
2	N.C.	N.C.
3	A ₂	出力端子/Output3 for motor
4	N.C.	N.C.
5	A ₂	出力端子/Output2 for motor
6	N.C.	N.C.
7	A ₁	出力端子/Output1 for motor
8	GND	GND端子/GND
9	H ₁ ⁺	ホール信号入力端子/Hall input Amp1. positive input
10	H ₁ ⁻	ホール信号入力端子/Hall input Amp1. negative input
11	H ₂ ⁺	ホール信号入力端子/Hall input Amp2. positive input
12	H ₂ ⁻	ホール信号入力端子/Hall input Amp2. negative input
13	H ₃ ⁺	ホール信号入力端子/Hall input Amp3. positive input
14	H ₃ ⁻	ホール信号入力端子/Hall input Amp3. negative input
15	N.C.	N.C.
16	FG3	FG信号出力端子/FG3 signal output terminal
17	FG2	FG信号出力端子/FG2 signal output terminal
18	FG1	FG信号出力端子/FG1 signal output terminal
19	V _H	ホールバイアス端子/Hall Bias
20	C _{NP}	位相補償用コンデンサ接続端子 /Capacitor connection pin for phase compensation
21	E _{CR}	出力電圧制御標準端子 /Torque control standard voltage input terminal
22	E _C	出力電圧制御端子/Torque control voltage input terminal
23	PS	パワーセーブ端子/ POWER SAVE switch
24	REV	逆転端子/Reverse terminal
25	V _{CC}	電源端子/Power supply for signal division
26	V _{M2}	12V用電源端子/Power supply2 for driver
27	V _{M1}	モータ電源端子/Power supply1 for driver
28	R _{HP}	出力電流検出用抵抗接続端子 /Power supply for driver division
FIN	FIN	GND

Q301 : RL5C357

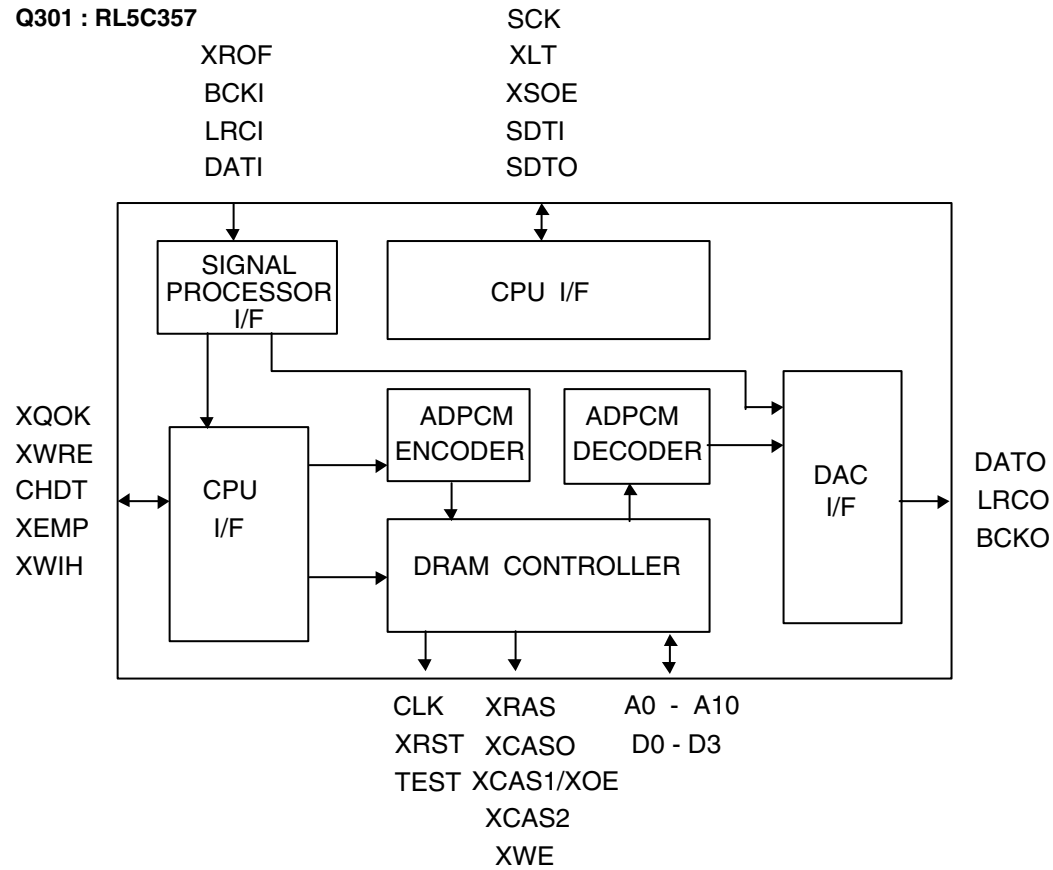

Pin	PIN NAME	I/O	FUNCTION	LOGIC	
				H	L
1	VCC	--	POWER SUPPLY	--	--
2	XQOK	Ipu	SUB CODE-Q OK SIGNAL FROM CPU	--	OK
3	XWRE	Ipu	WRITE ENABLE SIGNAL FROM CPU	--	PERMIT
4	XEMP	O	READ INHIBIT SIGNAL TO CPU	--	INHIBIT
5	XWIH	O	WRITE INHIBIT SIGNAL TO CPU	--	INHIBIT
6	XCAS2	O	DRAM CAS2 CONTROL	--	--
7	CHDT	O	DATA COMPARATIVE MONITOR SIGNAL OUTPUT TO CPU	COMPARE	--
8	A10	O	DRAM ADDRESS 10	--	--
9	CLK	I	16.9344MHz CLOCK INPUT	--	--
10	GND	--	GROUND	--	--
11	DATI	Ics	AUDIO DATA INPUT	--	--
12	LRCI	Ics	AUDIO L/R CLOCK INPUT	Lch	Rch
13	BCKI	Ics	AUDIO BIT CLOCK INPUT	--	--
14	BCKO	O	AUDIO BIT CLOCK OUTPUT	--	--
15	LRCO	O	AUDIO L/R CLOCK OUTPUT	Lch	Rch
16	DATO	O	AUDIO DATA OUTPUT	--	--
17	XROF	Ics	RAM OVERFLOW FROM SIGNAL PROCESSOR IC	--	OVER FLOW
18	RFCK	Ipu	FRAME CLOCK FROM SIGNAL PROCESSOR IC, DERIVED FROM THE CRYSTAL ACCURACY	--	--
19	SCOR	I	SUB CODE SYNC DETECT SIGNAL FROM SIGNAL PROCESSOR IC	--	--
20	XRST	Ics	SYSTEM RESET	--	RESET
21	SDTO	O	SERIAL DATA OUTPUT TO CPU	--	--
22	XSOE	Ipu	SERIAL DATA OUTPUT PERMISSION SIGNAL INPUT FROM CPU	--	PERMIT
23	TEST	Ipd	TEST MODE	--	--
24	XLT	Ics	LATCH INPUT FROM CPU	--	--
25	SDTI	Ics	SERIAL DATA INPUT FROM CPU	--	--
26	SCK	Ics	SERIAL DATA TRANSFER CLOCK INPUT FROM CPU	--	--
27	XCAS1/XOE	O	DRAM CAS1/OE CONTROL	--	--
28	XCAS0	O	DRAM CAS0 CONTROL	--	--
29	D2	I/O	DRAM DATA 2	--	--
30	D3	I/O	DRAM DATA 3	--	--
31	D0	I/O	DRAM DATA 0	--	--
32	D1	I/O	DRAM DATA 1	--	--
33	XWE	O	DRAM WE CONTROL	--	--
34	XCRAS	O	DRAM RAS CONTROL	--	--
35	A9	O	DRAM ADDRESS 9		
36	A8	O	DRAM ADDRESS 8		
37	A7	O	DRAM ADDRESS 7		
38	A6	O	DRAM ADDRESS 6		
39	A5	O	DRAM ADDRESS 5		
40	A4	O	DRAM ADDRESS 4		
41	A0	O	DRAM ADDRESS 0		
42	A1	O	DRAM ADDRESS 1		
43	A2	O	DRAM ADDRESS 2		
44	A3	O	DRAM ADDRESS 3		

Q302 : HY5117400BJ-60

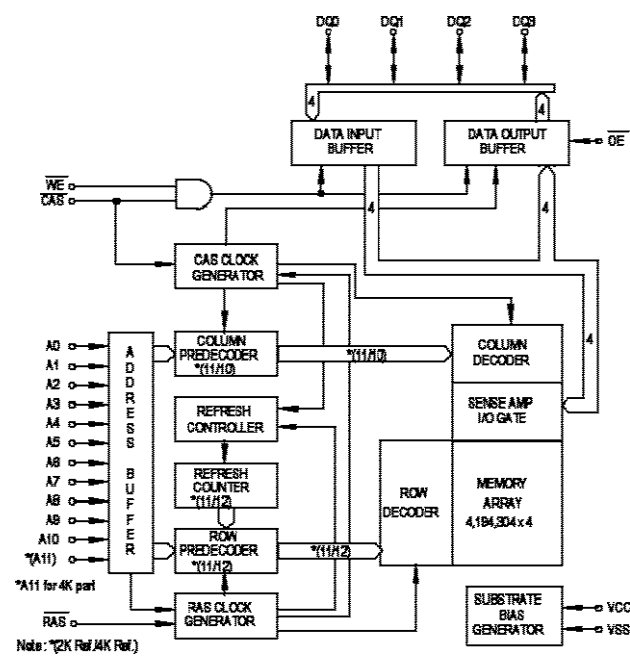

QU57 QU58 : 74HC165

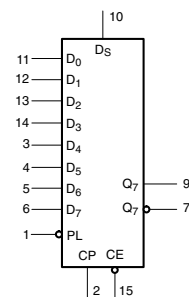

PIN NUMBER	SYMBOL	FUNCTION
1	\overline{PL}	Asynchronous parallel load input (active LOW)
2	CP	Clock input (LOW to HIGH, edge-triggered)
7	$\overline{Q_7}$	Complementary output from the last stage
8	GND	Ground (0 V)
9	Q_7	Serial output from last stage
10	D_S	Serial data input
11, 12, 13, 14, 3, 4, 5, 6	D_0 to D_7	Parallel data inputs
15	\overline{CE}	Clock enable input (active LOW)
16	V_{CC}	Positive supply voltage

QU04 QU56 : 74HC4094

PIN NO.	SYMBOL	NAME AND FUNCTION
1	STR	strobe input
2	D	serial input
3	CP	clock input
4, 5, 6, 7, 14, 13, 12, 11	QP_0 to QP_7	parallel outputs
8	GND	ground (0 V)
9, 10	QS_1, QS_2	serial outputs
15	OE	output enable input
16	V_{CC}	positive supply voltage

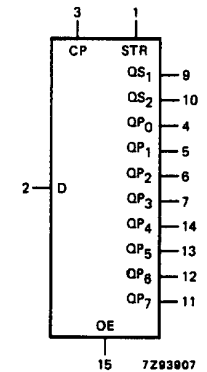

6. WIRING DIAGRAM

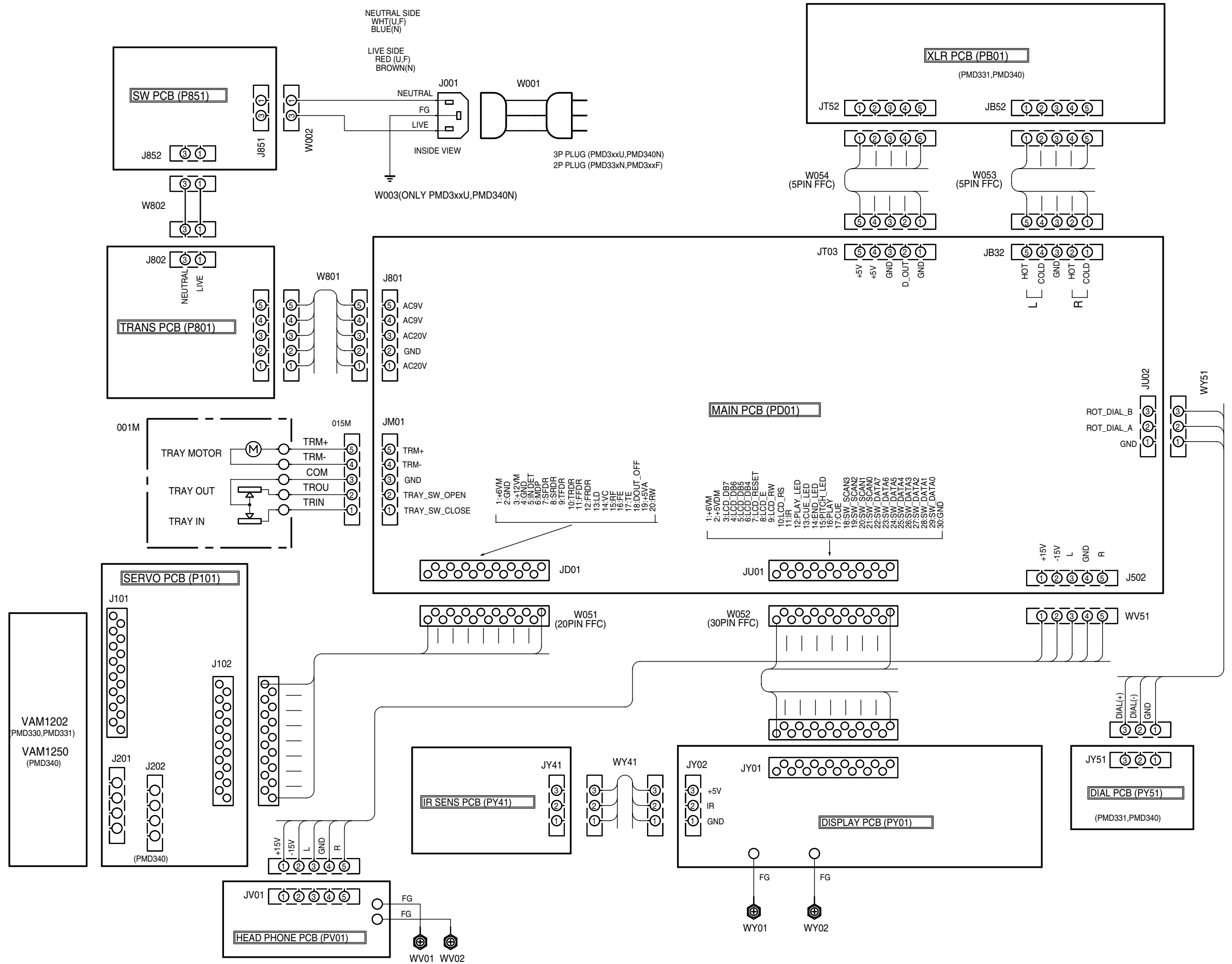

7. BLOCK DIAGRAM

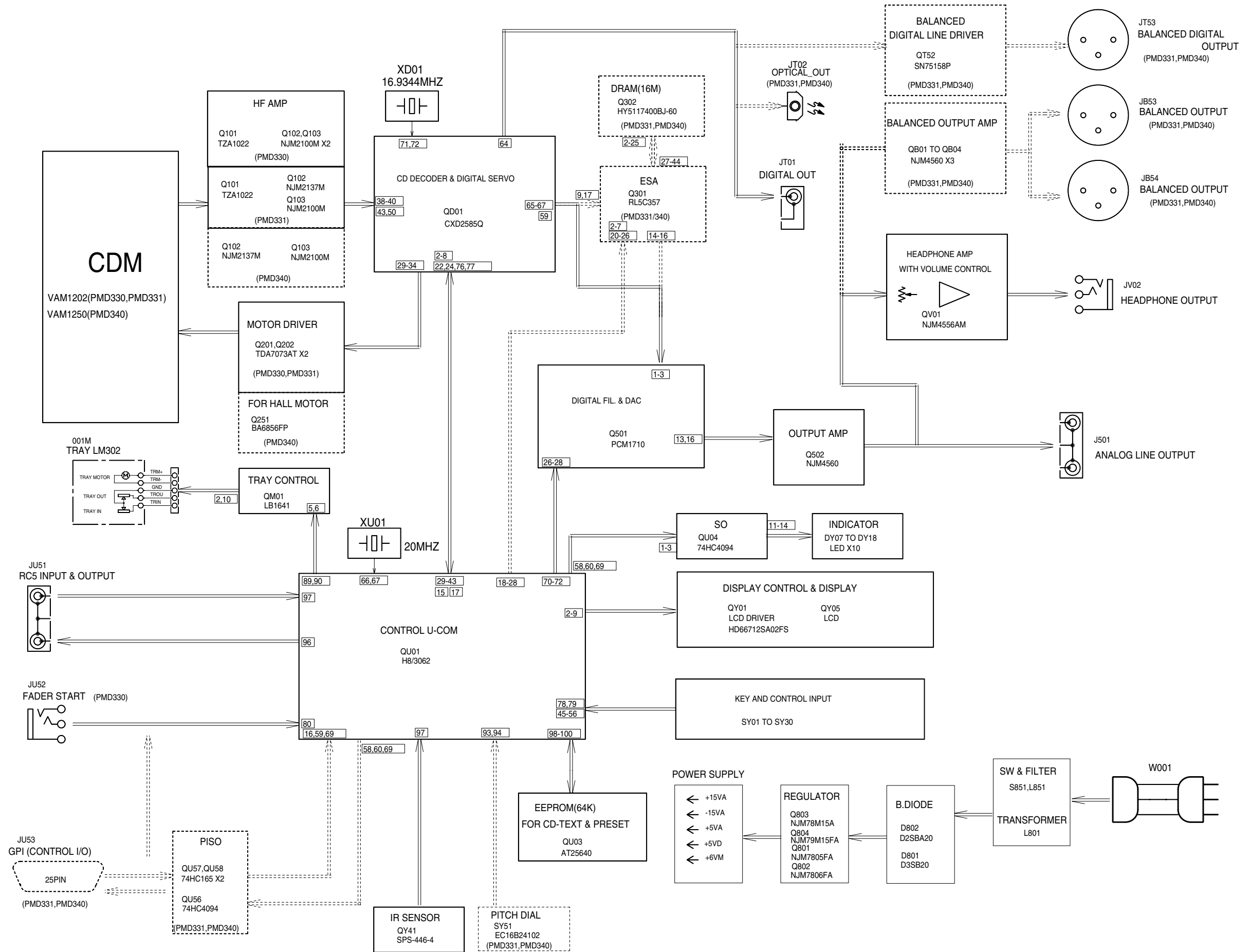

8. SCHEMATIC DIAGRAM

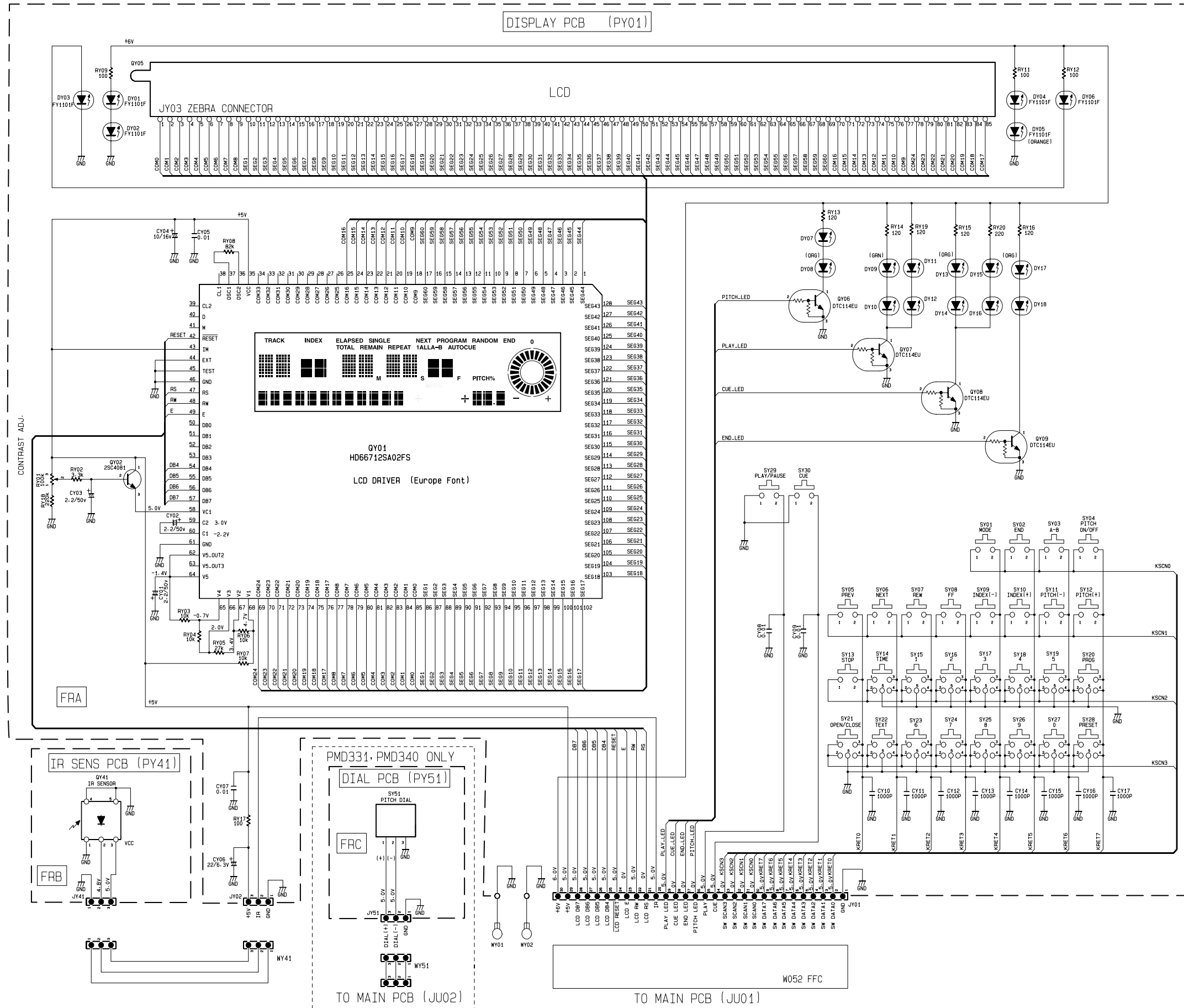

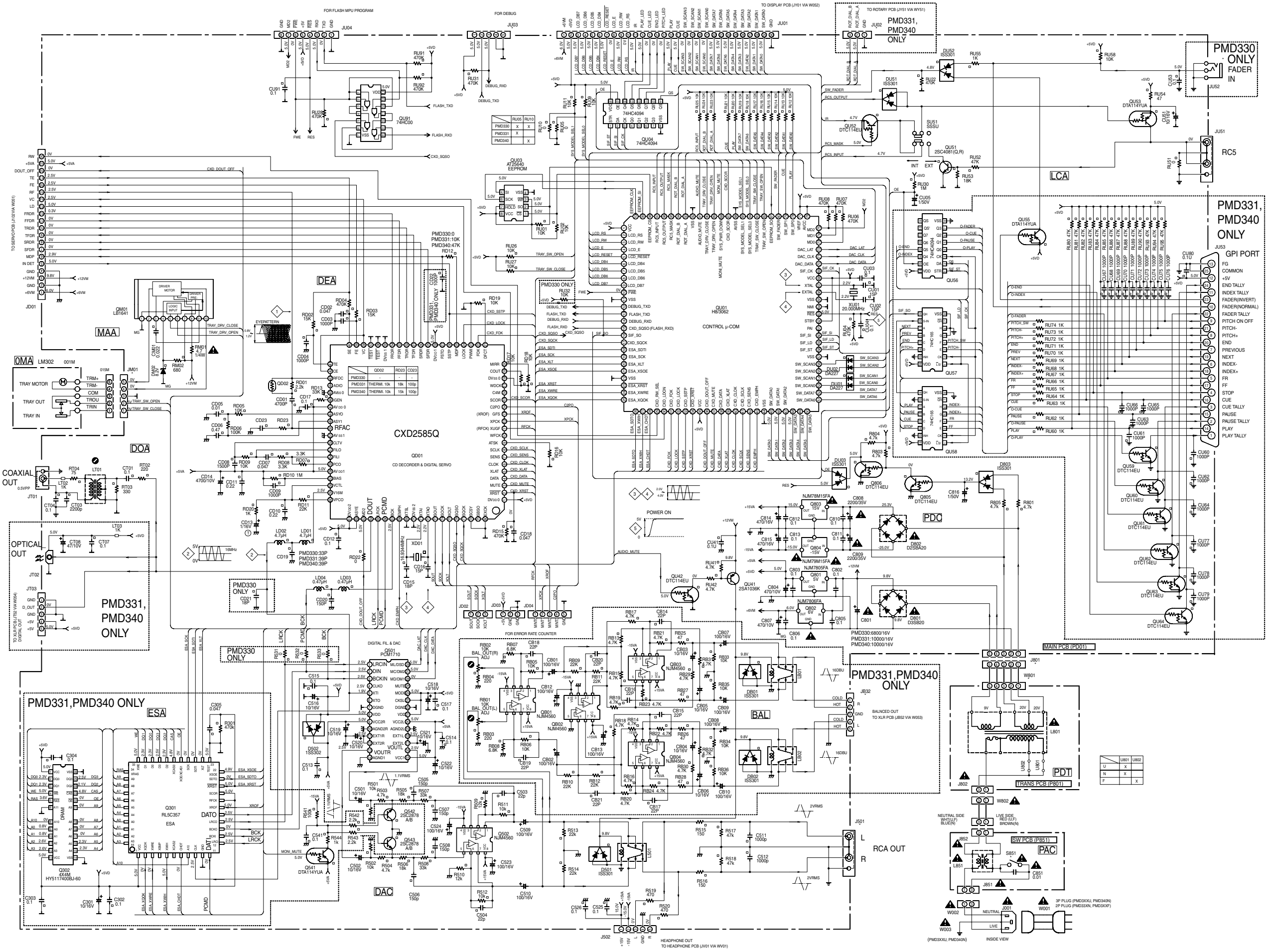

PMD330, PMD331 ONLY

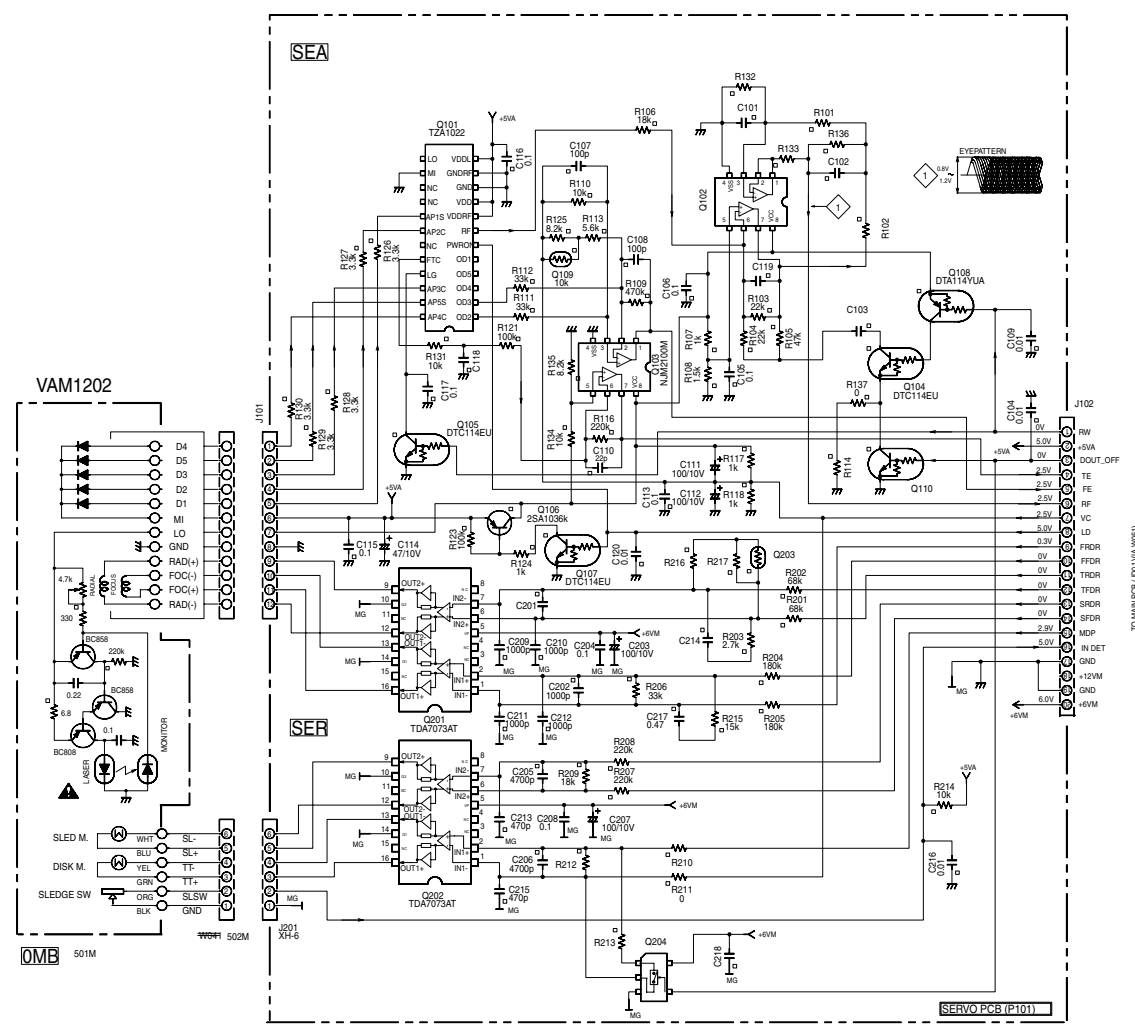

	Q102	R101	R102	R132	R133	R136	C101	C102	C103	C119	Q110	R114	C118
PMD330	NJM2100M	—	0	0	—	0	—	—	10p	2p	—	0	100p
PMD331	NJM2137M	680	680	—	0	—	27p	220p	27p	—	DTC114EU	47k	47p

	Q203	R216	R217	C201	C214	Q204	R210	R212	R213	C218
PMD330	—	0	8.2k	4700p	0.47	—	22k	1k	—	—
PMD331	10k 7H	12k	15k	1000p	0.22	TC4566F	0	4.7k	1k	0.1

PMD340 ONLY

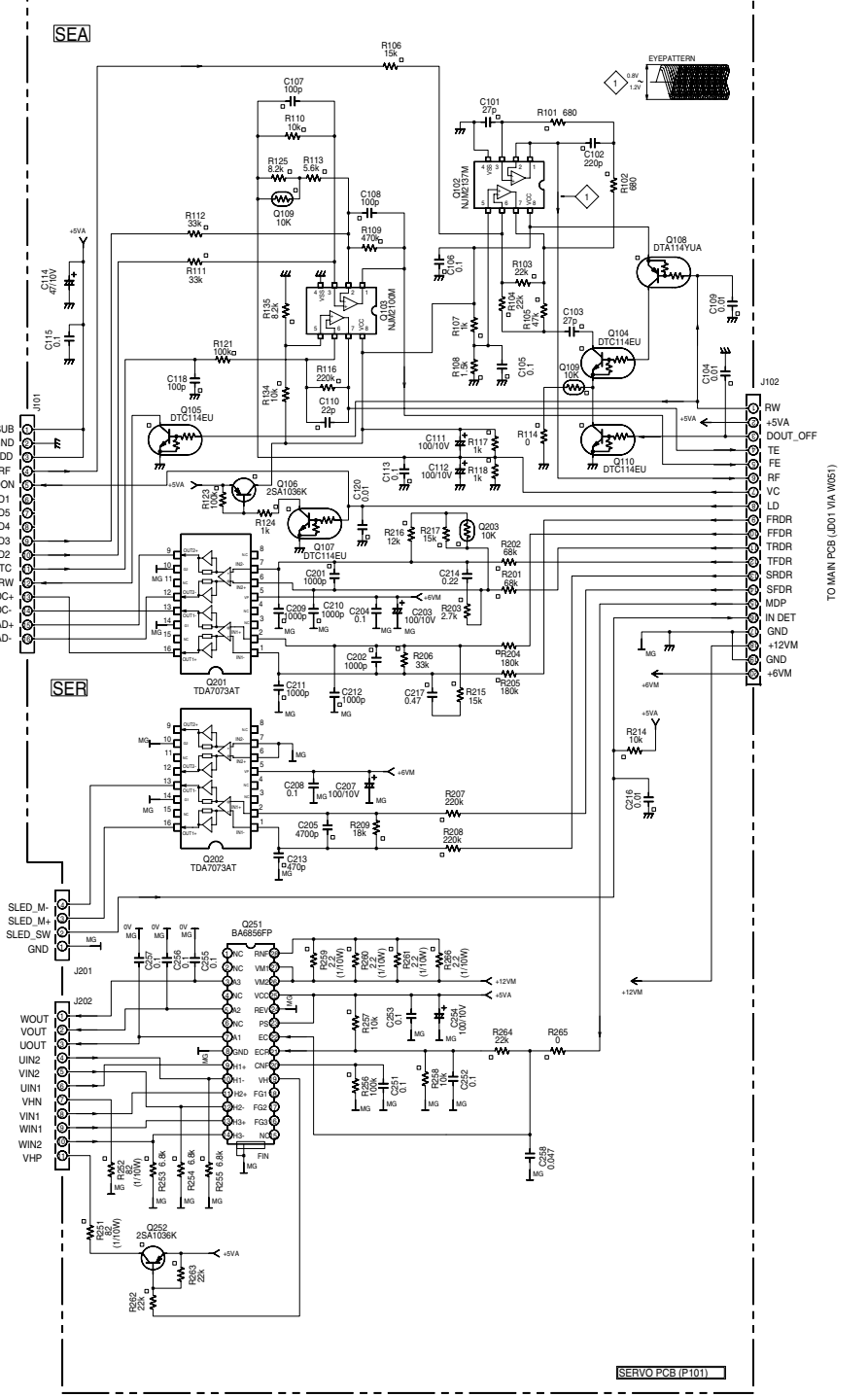
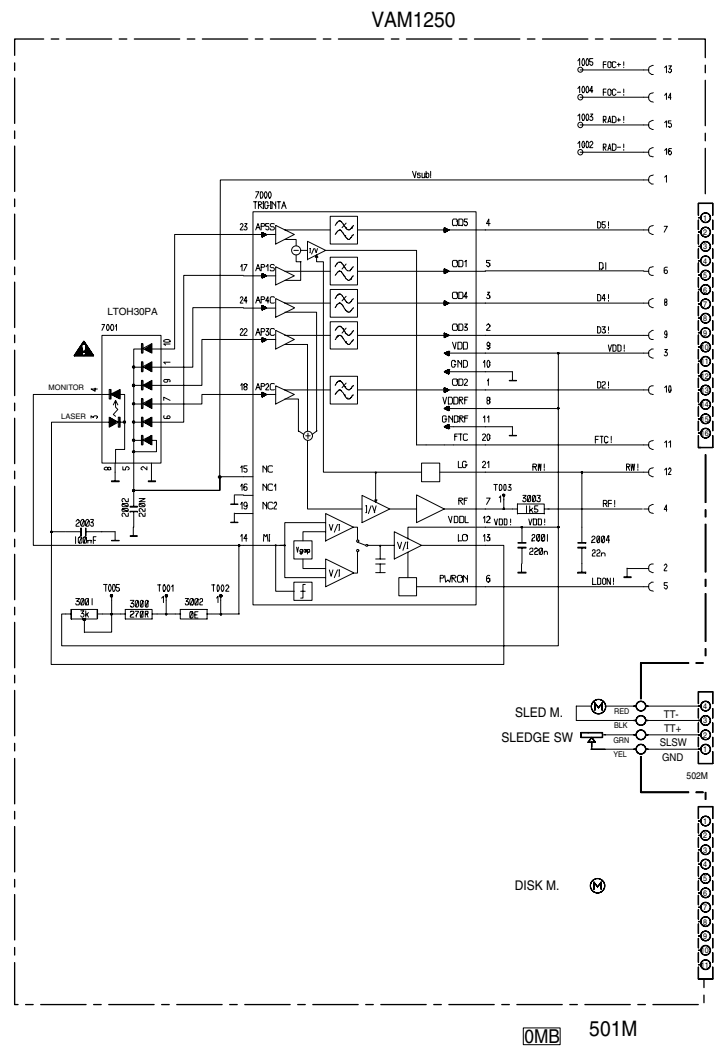

9. PARTS LOCATION

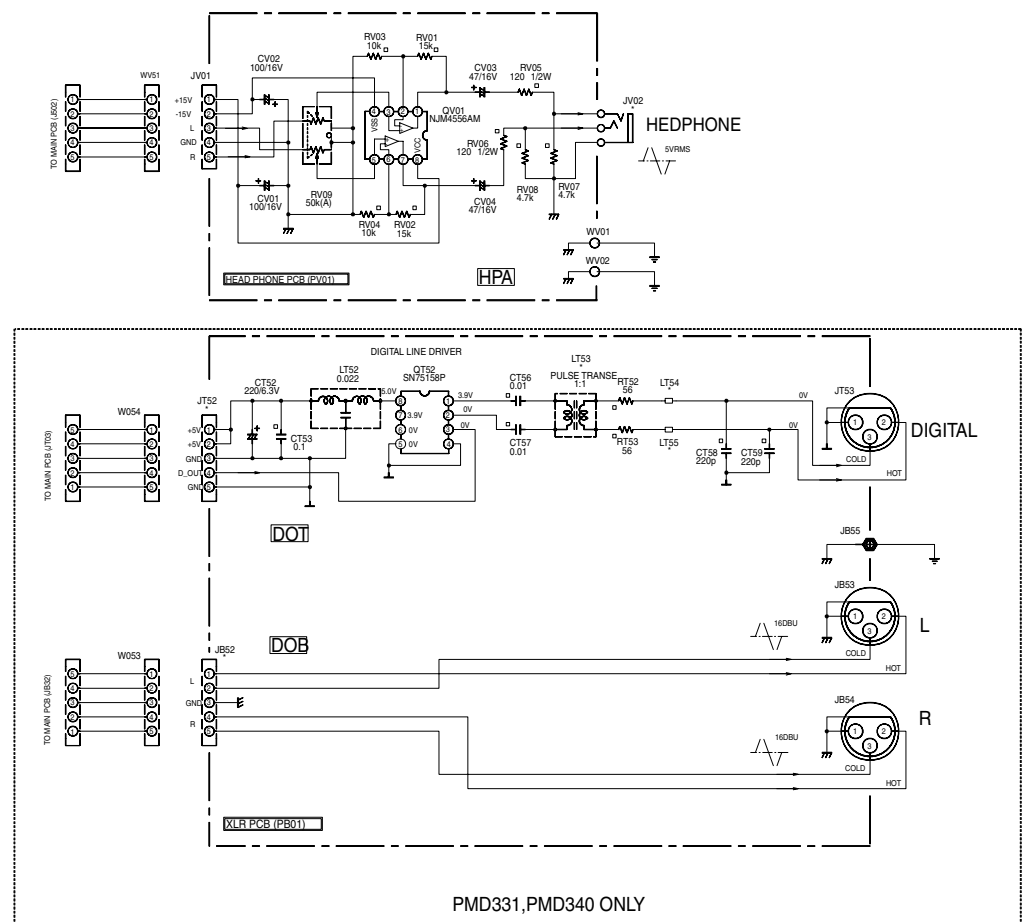

PY01

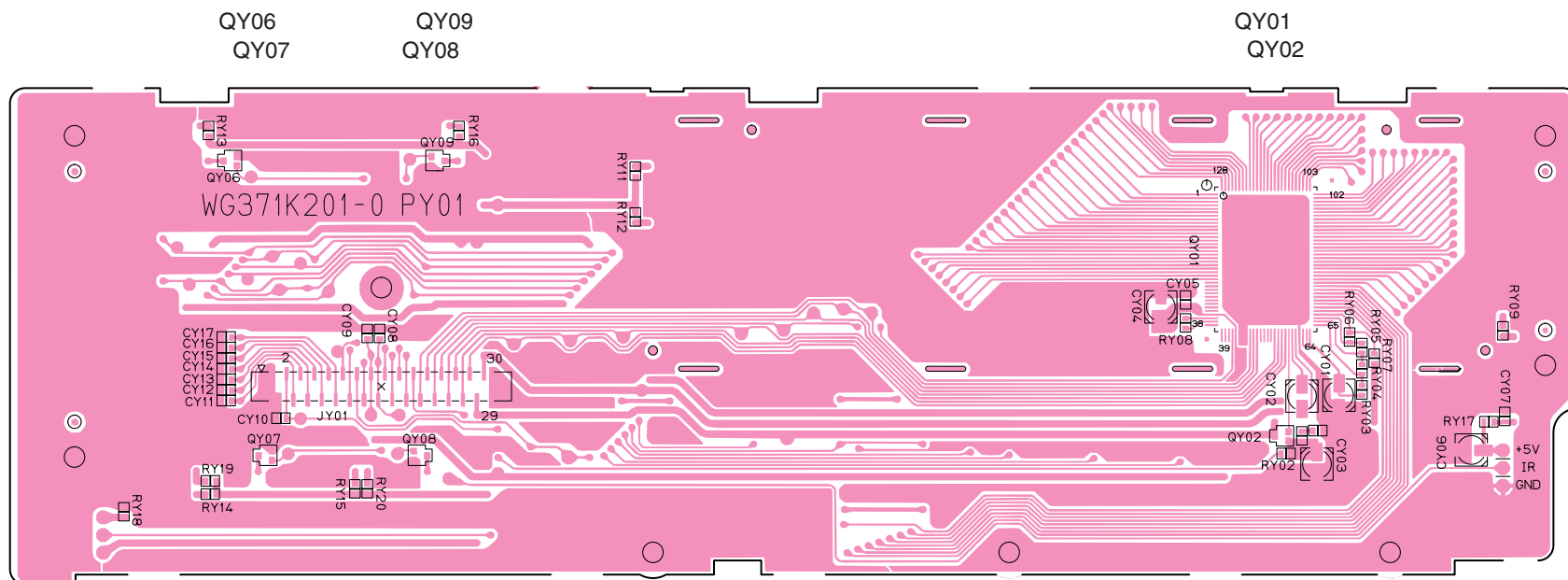

PY01

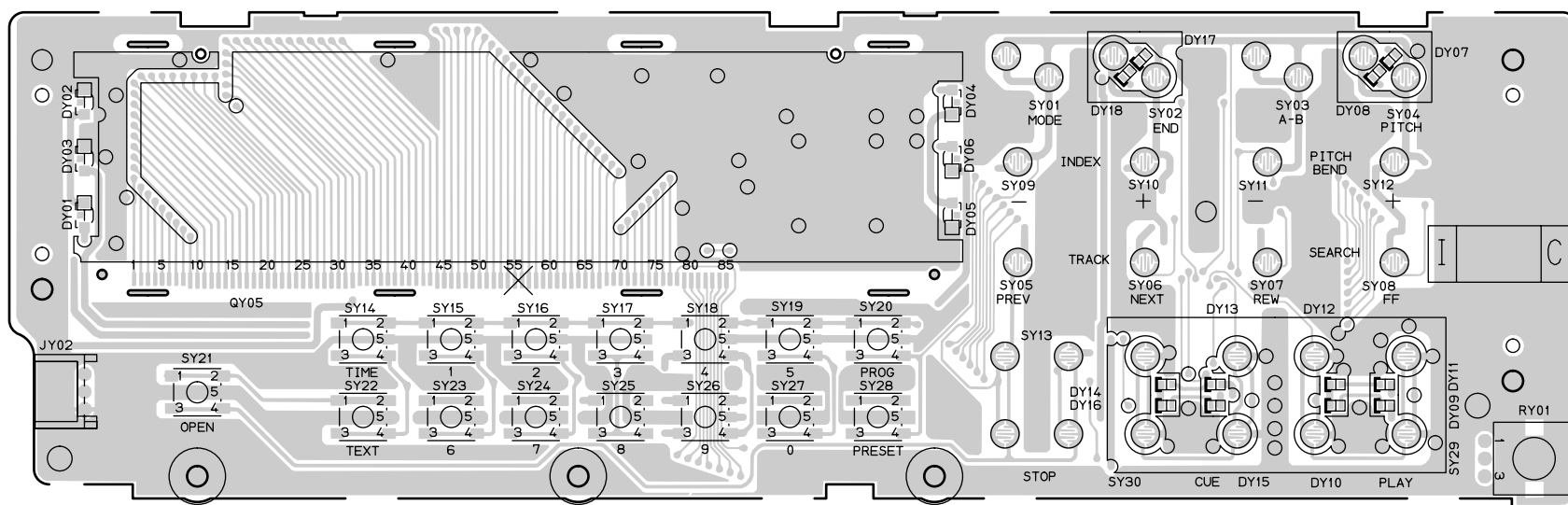

PV01

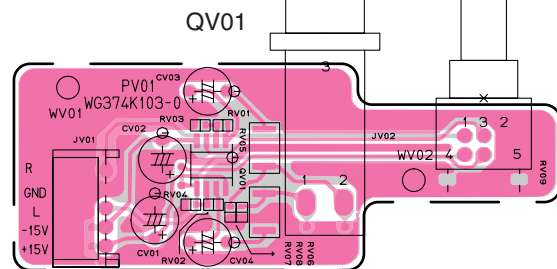

PY41

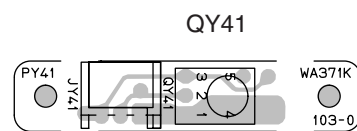

PY51

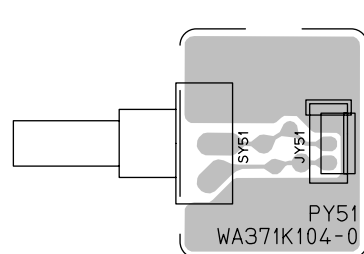

PB01

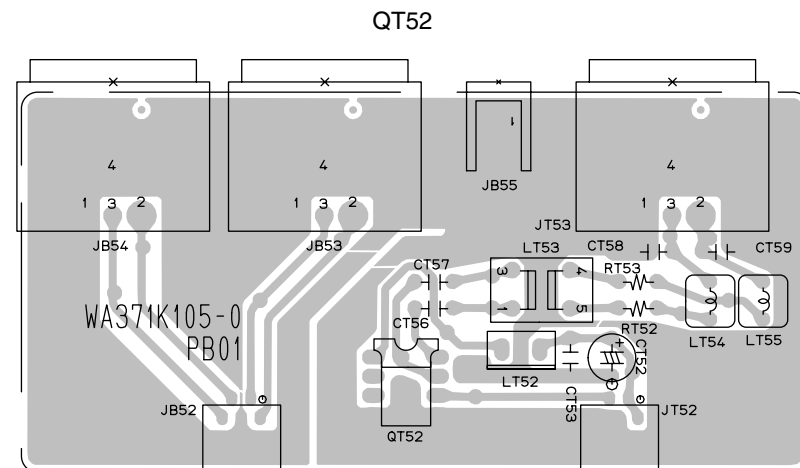

PD01

Q301 Q302
Q501 Q541
Q502

QB03 QB02
QB01

QU41 QU42
QB04

QU91

QU04

QU01

QD01

QU03
QU52 QU51

Q802 Q801
Q804

Q803
Q806 Q805

QM01

QU58 QU57
QU64 QU63 QU62

QU56
Q61 QU60 QU59

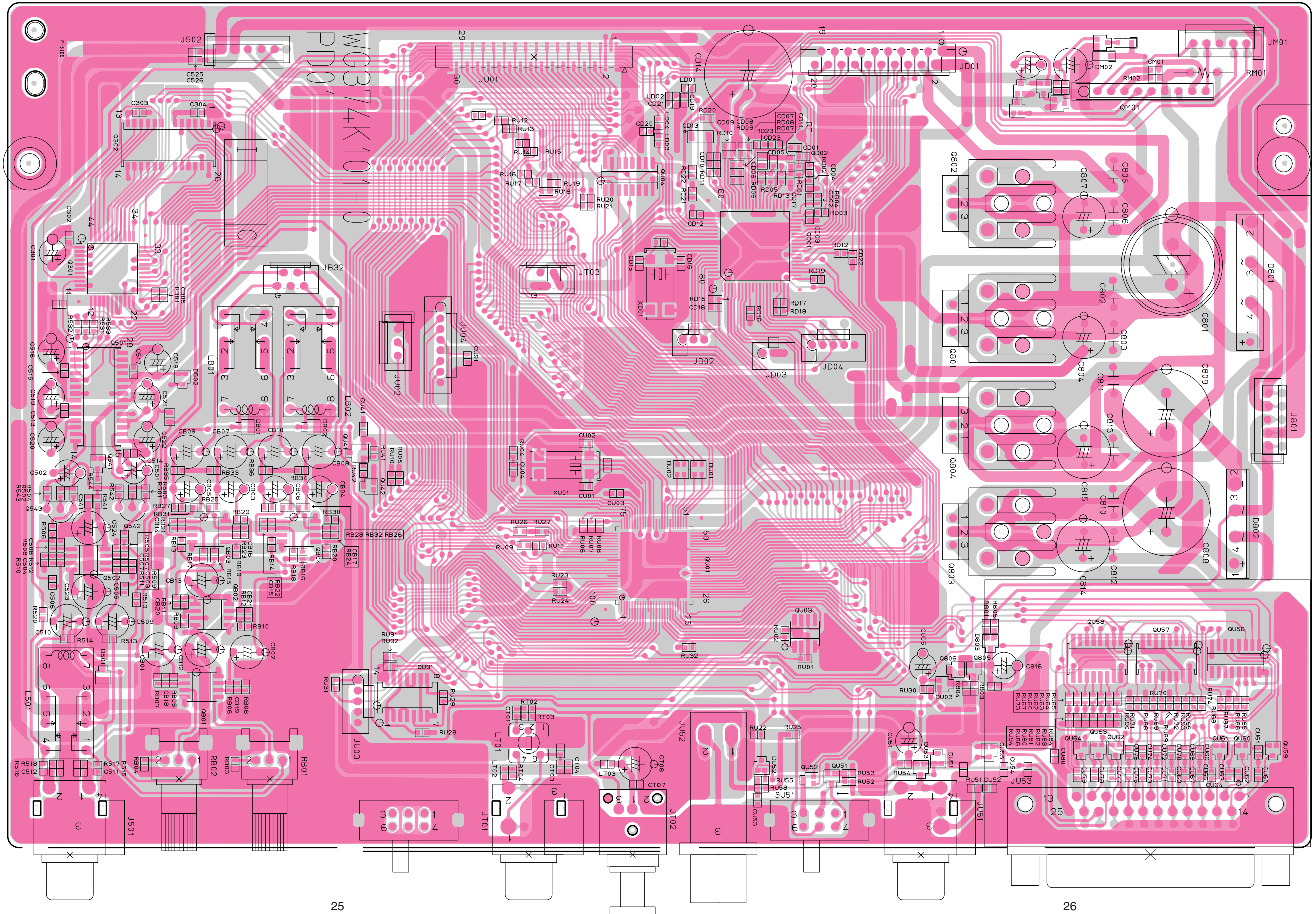

10. EXPLODED VIEW AND PARTS LIST

P101 (PMD330, PMD331)
Q110 Q108 Q112
Q107 Q106 Q103 Q102
Q105 Q111 Q201 Q101 Q204 Q202

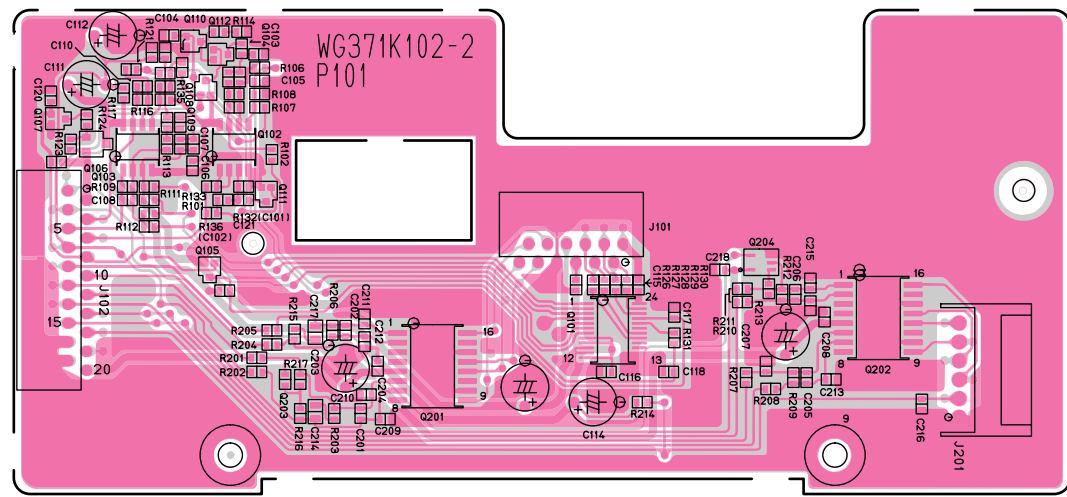

P101 (PMD340)
Q110 Q108 Q112
Q107 Q106 Q103 Q102
Q105 Q111 Q202 Q251 Q204 Q252 Q201

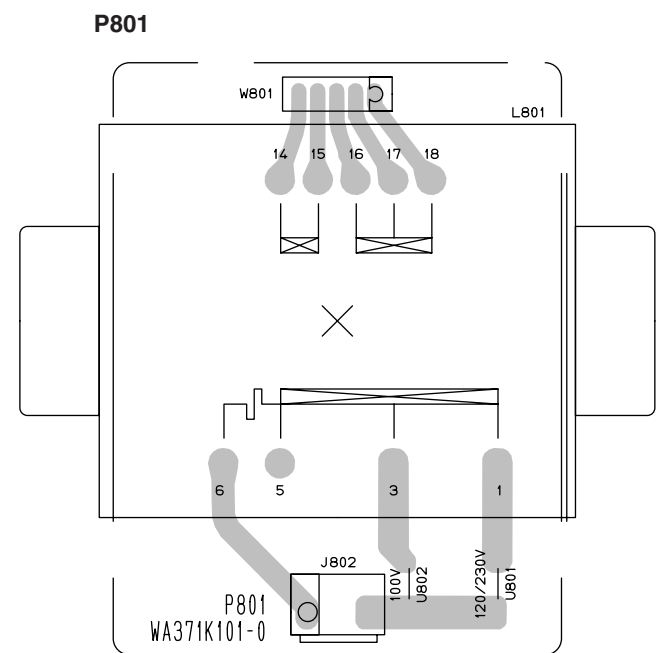
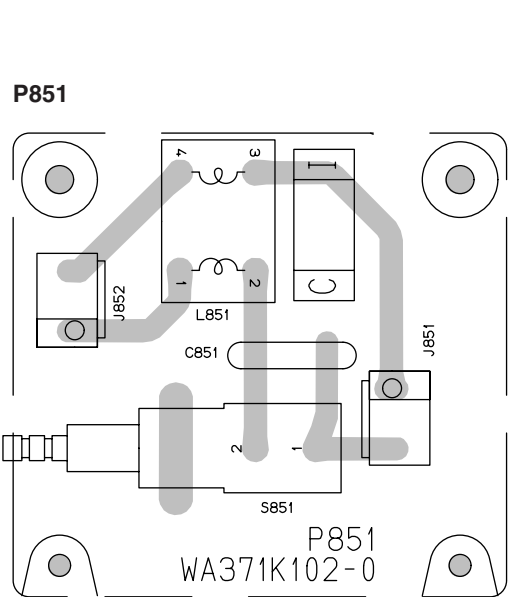
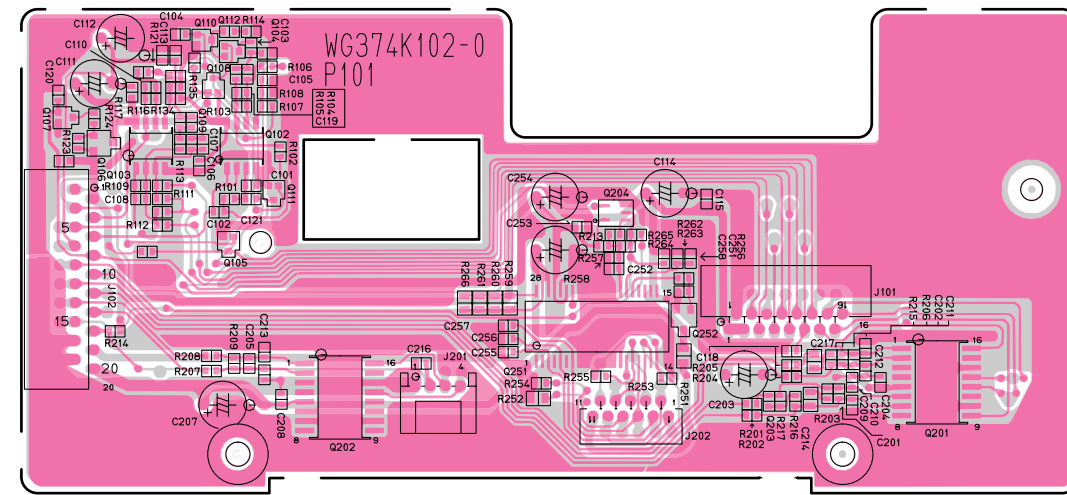

POS. NO	VERS. COLOR	PART NO. (FOR PCS)	DESCRIPTION	PART NO. (MUJ)	POS. NO	VERS. COLOR	PART NO. (FOR PCS)	DESCRIPTION	PART NO. (MUJ)
001B	BLACK		FRONT PANEL PMD330 BLK	371K248010	062G			STICKER	***
001B	GRAY	9965 000 01604	FRONT PANEL PMD330 GRAY	371K248020	092G			INNER LASER CAUTION	***
001B	BLACK		FRONT PANEL PMD331 BLK	371K248110	094G			LABEL LASER CAUTION	***
001B	GRAY	9965 000 01726	FRONT PANEL PMD331 GRAY	371K248120	901G			REAR PANEL	***
001B	BLACK		FRONT PANEL PMD340 BLK	371K248210	907G			LABEL	***
001B	GRAY	9965 000 01721	FRONT PANEL PMD340 GRAY	371K248220	909G			B.H. TAP. SCREW	***
					911G			PH.TAP.SCREW	***
003B	BLACK		FRONT CHASSIS PMD330 BLK	371K105020	001M		9965 000 01625	NEW LOADER LM302	305K304680
003B	GRAY	9965 000 01605	FRONT CHASSIS PMD330 GRAY	371K105030				OLD TRAY BLK	
003B	BLACK		FRONT CHASSIS BLACK	371K105040	005M		4822 464 10054	FRAME K	305K401500
003B	GRAY	9965 000 01722	FRONT CHASSIS PMD331/340 GRAY	371K105050	010M		4822 361 21741	MOTOR	MM0030002R
003B	340/U		FRONT CHASSIS PMD340 USA BLACK	371K105060	015M		4822 321 63208	CABLE	YB00380590
005B	BLACK		WINDOW BLK	371K158010	016M		4822 271 30873	MINI SWITCH	SM01020620
005B	GRAY	9965 000 01606	WINDOW GRAY	371K158020	020M		4822 522 33521	GEAR	305K058030
006B		9965 000 01607	IR LENS	371K355020	021M		4822 528 81537	PULLEY	305K262010
007B	BLACK		ESCUTCHEON	292K063220	025M		4822 522 33522	GEAR K	305K058500
007B	340/U		ESCUTCHEON PMD340 USA	292K063260	030M		4822 358 31325	BELT	305K264010
007B	GRAY	9965 000 01608	ESCUTCHEON	292K063230	031M		4822 459 50976	MASK	305K303010
009B	BLACK		POWER BUTTON	371K270150	035M		4822 443 51265	CASE	305K064110
009B	GRAY	9965 000 01609	POWER BUTTON	371K270160	036M		9965 000 01626	SUSPENSION	371K056010
010B	BLACK		BUTTON	371K270170	040M		4822 402 11212	NEW LIFT ARM	305K002050
010B	GRAY	9965 000 01610	BUTTON	371K270180	043M		9965 000 00234	CASE K NEW GEAR/OLD TRAY	305K064600
011B			LCD SHEET	***	045M			CASE BLACK	305K064010
012B	BLACK		ROTARY KNOB PMD331/340 BLACK	372K154010	046M			SPRING	305K115010
012B	GRAY	9965 000 01723	ROTARY KNOB PMD331/340 GRAY	372K154020	050M			CAM	305K054010
013B			LCD SPACER	***	051M			NEW SLIDER GEAR	305K058050
015B			LCD HOLDER	***	051M			SPRING	305K115020
016B			INSULATOR FOR 015B	***	060M	4822 492 33495		MECHANISM VAM 1202	371K304500
017B			LCD REFLECTOR	***	501M	330,331	9965 000 01627	9305 022 20200	
019B			LCD LENS	***	501M	340	9965 000 01724	9305 022 25001	374K304500
020B			WEIGHT FOR KNOB	***				BRACKET	***
021B			BRACKET FOR PHONE JACK	***	510M			STOPPER FOR DISC	371K114010
023B	BLACK		KNOB FOR PHONE VOLUME	284T154310	518M			STOPPER FOR DISC	371K114020
023B	GRAY	9965 000 01611	KNOB FOR PHONE VOLUME	284T154050	520M			ADHESIVE FOR 520M	371K122010
027B		9965 000 01612	BUTTON RUBBER	371K270010	522M			CLAMPER ASSY VAM1202	371K005500
029B		9965 000 01614	BUTTON MODE KEY	371K270020	555M	330,331		CLAMPER ASSY VAM1250	374K005500
031B		9965 000 01615	BUTTON END KEY	371K270030	555M	340	9965 000 01725		
033B		9965 000 01616	BUTTON A-B KEY	371K270040	▲ J001	/F	9965 000 01313	JACK 2P AC INLET M1910-H	YJ04002440
035B		9965 000 01617	BUTTON PITCH KEY	371K270050	▲ J001	/N	9965 000 01313	JACK 2P AC INLET M1910-H	YJ04002440
037B		9965 000 01618	BUTTON +/- KEY	371K270070	▲ J001	/U		JACK 3P AC INLET M1910-D	YJ04002450
039B		9965 000 01619	BUTTON NEXT/PREV KEY	371K270080	W051		9965 000 01602	JUMPER LEAD 20P FFC	YU20170500
041B		9965 000 01620	BUTTON FF/FR KEY	371K270090	W052		9965 000 01603	JUMPER LEAD 30P FFC	YU30170520
043B		9965 000 01621	BUTTON STOP KEY	371K270100	W053	331,340		JUMPER LEAD 5P FPC	YU05090500
045B		9965 000 01622	BUTTON CUE KEY	371K270110	W054	331,340		JUMPER LEAD 5P FPC	YU05090500
047B		9965 000 01623	BUTTON PLAY KEY	371K270120					
001D	/U1B		LID TOP COVER BLACK	292J257030				PACKING	
003D	/U1B		MOUNT BRACKET L	371K160040	001T	/F		USER MANUAL	371K851110
005D	/U1B		MOUNT BRACKET R	371K160050	001T	/N	9965 000 01628	USER MANUAL	371K851310
					001T	/U		USER MANUAL	371K851250
001G			CHASSIS	***	▲ W001	/F		MAINS CORD 2P 12A 125V	ZC02001180
003G			SIDE BRACKET L	***	▲ W001	330/N	4822 321 11439	MAINS CORD 2P 10A 250V	ZC01803080
007G			SIDE BRACKET R	***				CLASS2	
011G		9965 000 01624	LEG BLACK	371K057010	▲ W001	340/N	4822	MAINS CORD 3P 10A 250V	ZC02003180
012G			BUFFER FOR LEG	371K056020	▲ W001	/U		CLASS1	
015G			LOADER BRACKET	***				MAINS CORD 3P 10A 125V	ZC02002180
026G			BRACKET FOR PD01	***					
030G			SUPPORT FOR PD01	***					
031G			SUPPORT FOR P801	***	001S	330		NOT STANDARD	
037G		4822 402 10913	LINK	318K121010	001S	331		SPEAR PARTS	
039G	/U		SCREW FOR GND	***	001S	340		PACKING CASE PMD330	371K801010
045G			LABEL FOR GND	***	003S			PACKING CASE PMD331	372K801010
060G			SHEET	***	001S			PACKING CASE PMD340	374K801010
					003S			CUSHION	371K809010
					W004	/U		AUDIO CABLE	ZD01000330

NOTE : *** =PART IS LISTED FOR REFERENCE ONLY, MARANTZ WILL NOT SUPPLY THESE PARTS.

SYMBOL	STYLE	PARTS NAME	MARK	MATERIAL/FINISH
5110		+B. H. M. SCREW	(M)	STEEL/COPPER
5127		+B. H. TAP TITE SCREW (W)	(U)	STEEL/BLACK
5128		+B. H. TAP TITE SCREW (B TYPE)	(A)	STEEL/CHROMATE
5404		SPRING LOCK WASHERS	(R)	STEEL/UNICHROMATE
5405		TOOTHED LOCK WASHERS	(N)	PHOSPHOR BRONZE/NICKEL

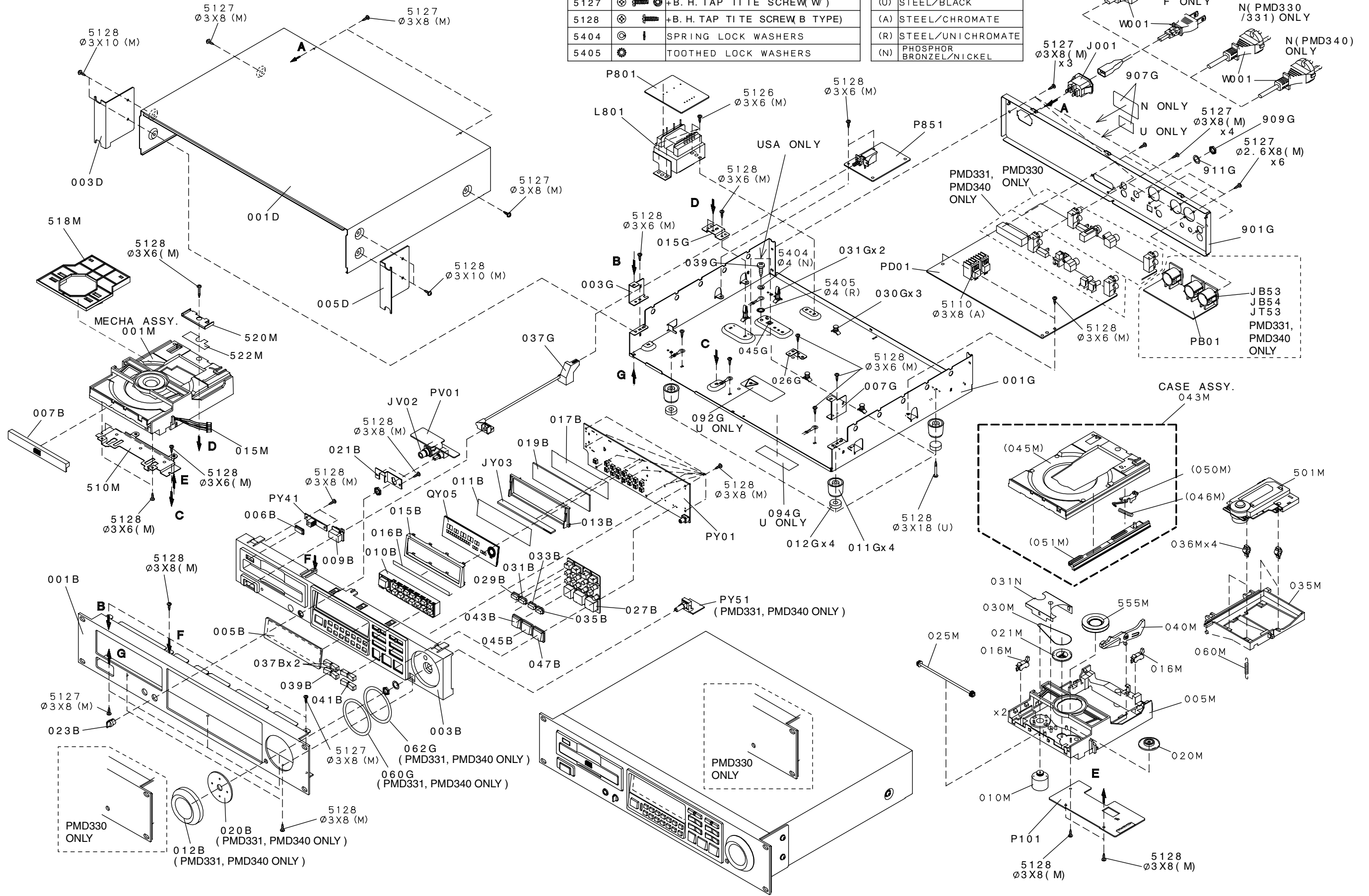

11. TECHNICAL DESCRIPTION

1. RC5 Code

This product is able to communicate to the other MARANTZ products with the RCA Pin cable.

1. RC5コード

RCA Pinコードを介して他の機器と通信できる。

Command Name	Code	Decode			Binary			
		SYS	COM	DATA	START	SYS	COM	DATA
Play	2053	20	53		11	10100	110101	
Pause	2048	20	48		11	10100	110000	
Cue	2059-10	20	59	10	11	10100	111011	1010
Stop	2054	20	54		11	10100	110110	
FF	2052	20	52		11	10100	110100	
FR(REW)	2050	20	50		11	10100	110010	
Index+	2034	20	34		11	10100	100010	
Index-	2035	20	35		11	10100	100011	
Next	2032	20	32		11	10100	100000	
Previous	2033	20	33		11	10100	100001	
Pitch+	2038	20	38		11	10100	100110	
Pitch-	2039	20	39		11	10100	100111	
Pitch Bend+ *2 *3	2038-10	20	38	10	11	10100	100110	1010
Pitch Bend- *2 *3	2039-10	20	39	10	11	10100	100111	1010
A-B	2059	20	59		11	10111	111011	
Program	2041	20	41		11	10100	101001	
Pitch On/Off	2037	20	37		11	1010	100101	
Open/Close	2045	20	45		11	10100	101101	
Time	2011	20	11		11	10100	1011	
Mode	2036-10	20	36	10	11	10100	100100	1010
Preset	2041-12	20	41	12	11	10100	101001	1100
END monitor	2043-10	20	43	10	11	10100	101011	1010
CD-TEXT	2088	20	88		10	10100	110000	
0	2000	20	00		11	10100	0	
1	2001	20	01		11	10100	1	
2	2002	20	02		11	10100	10	
3	2003	20	03		11	10100	11	
4	2004	20	04		11	10100	100	
5	2005	20	05		11	10100	101	
6	2006	20	06		11	10100	110	
7	2007	20	07		11	10100	111	
8	2008	20	08		11	10100	1000	
9	2009	20	09		11	10100	1001	
SERVICE *1	166363	16	63	63	11	10000	111111	111111
OUTPUT Connect	1856	18	56		11	10010	111000	
OUTPUT Disconnect	1857	18	57		11	10010	111001	

- *1 The service code is available during STOP mode only.
- *2 The Pitch Bend+ and Pitch Bend- are not available with the digital out on.
- *3 The Pitch Bend+ and Pitch Bend- are not available on PMD330.

- *1 サービスコードは STOP状態の時のみ受け付ける。
- *2 Pitch Bend+、Pitch Bend- はデジタルアウト On時には受け付けない。
- *3 表内の Pitch Bend+、Pitch Bend- は PMD330では No Action とする。

5. GPI code

The GPI code is input from external controller with D-Sub 25 Pin connector.

2. GPI コード

D-Sub25Pinコネクタで外部のコントローラーより入力される。

Pin	Name	I/O	Active
1	PLAY TALLY	O	Low
2	PAUSE TALLY	O	Low
3	CUE TALLY	O	Low
4	STOP	I	Low
5	FR	I	Low
6	INDEX-	I	Low
7	PREVIOUS	I	Low
8	PITCH+	I	Low
9	PITCH ON/OFF	I	Low
10	FADER(NORMAL)	I	Low
11	INDEX #2/#3 TALLY	O	Low
12	+5V	-	---
13	FG COMMON	-	---
14	PLAY	I	Low
15	PAUSE	I	Low
16	CUE	I	Low
17	FF	I	Low
18	INDEX+	I	Low
19	NEXT	I	Low
20	END	I	Low
21	PITCH-	I	Low
22	FADER TALLY	O	Low
23	FADER(INVERT)	I	High
24	END TALLY	O	Low
25	TALLY COMMON	-	---

* The fader start is on during PLAY, and off during PAUSE.

* The index is output by pulse signal.

When the index #2 is selected, the pulse signal of 200ms is output at the top of index #2.

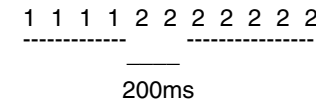

When the index #3 is selected, the pulse signal of 200ms is output at the top of index #3.

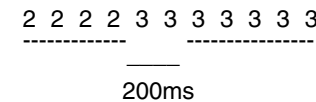

3. Double speed Reading

The disc (spindle) motor of PMD331/340 rotates at double speed for the Instant start & Anti-shock (shockproof) behavior function.

The data that is read out at double speed from a CD is put into the shockproof memory control & DRAM.

The data that is in the shockproof memory is forwarded to the DAC and is played back at normal speed.

When it is set Digital Out to "ON" on the preset menu, the disc (spindle) motor rotates at normal speed, and the data is read at normal speed.

Therefore, Digital output is always outputted at normal speed.

PMD330 doesn't have the shockproof memory control. Therefore the disc (spindle) motor of PMD330 always rotates at normal speed.

※ Fader Start は、PlayでOnし、Pause状態でOffとなる。

※ Indexはパルスで出力する。

Index #2選択時、Index #2の頭で200msのパルスを出力する。

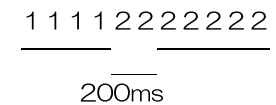

Index #3選択時、Index #3の頭で200msのパルスを出力する。

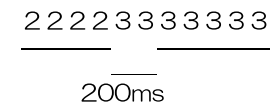

3. 2倍速について

PMD331/340は、Instant start & Anti-shock (shockproof) behavior 機能の為に、2倍速でDisc (Spindle) Motor を回転させています。

CDから2倍速にて読み出されたデータは、Shokproof memory control & DRAMにいったんメモリーします。

ここでメモリーされたデータは1倍速にてShokproof memory control よりDACに転送され通常のスピードで再生されます。

但し、Preset MenuにてDigital Out "ON" に設定した場合は、1倍速でDisk (Spindle) Motor は回転し1倍速でデータの読み出しが行われます。

よって、Digital 出力は常に1倍速で出力されます。

PMD330はShokproof memory control を搭載していないので常にDisc (Spindle) Motor は1倍速にて回転します。

12. ELECTRICAL PARTS LIST

ASSIGNMENT OF COMMON PARTS CODES.

RESISTORS

R***: 1) GD05 × × × 140, Carbon film fixed resistor, ±5% 1/4W

R***: 2) GD05 × × × 160, Carbon film fixed resistor, ±5% 1/6W

① — Resistance value

Examples ;

① Resistance value

0.1 Ω 001 10 Ω 100 1 kΩ 102 100 kΩ 104
 0.5 Ω 005 18 Ω 180 2.7 kΩ 272 680 kΩ 684
 1 Ω 010 100 Ω 101 10 kΩ 103 1 MΩ 105
 6.8 Ω 068 390 Ω 391 22 kΩ 223 4.7 MΩ 475

Note : Please distinguish 1/4W from 1/6W by the shape of parts used actually.

CAPACITORS

C***: CERAMIC CAP.

3) DD1 × × × × 370, Ceramic capacitor
 Disc type
 Temp.coeff.P350 ~ N1000, 50V
 ② — Capacity value
 ③ — Tolerance

Examples ;

② Tolerance (Capacity deviation)

±0.25 pF 0
 ±0.5 pF 1
 ±5% 5

* Tolerance of COMMON PARTS handled here are as follows :

0.5 pF ~ 5 pF ±0.25 pF
 6 pF ~ 10 pF ±0.5 pF
 12 pF ~ 560 pF ±5%

③ Capacity value

0.5 pF 005 3 pF 030 100 pF 101
 1 pF 010 10 pF 100 220 pF 221
 1.5 pF 015 47 pF 470 560 pF 561

C***: CERAMIC CAP.

4) DK16 × × × × 300, High dielectric constant ceramic capacitor
 Disc type
 Temp.chara. 2B4, 50V
 ④ — Capacity value

Examples ;

④ Capacity value

100 pF 101 1000 pF 102 10000 pF 103
 470 pF 471 2200 pF 222

C***: 5) ELECTROLY CAP. (⏏), 6) FILM CAP. (⏏)

5) EA × × × × × 10, Electrolytic capacitor
 One-way lead type, Tolerance ±20%
 ⑤ — Working voltage
 ⑥ — Capacity value

Examples ;

⑤ Capacity value

0.1 μF 104 4.7 μF 475 100 μF 107
 0.33 μF 334 10 μF 106 330 μF 337
 1 μF 105 22 μF 226 1100 μF 118
 2200 μF 228

⑥ Working voltage

6.3V 006 25V 025
 10V 010 35V 035
 16V 016 50V 050

6) DF15 × × × 350 — Plastic film capacitor
 DF15 × × × 310 — One-way type, Mylar ±5% 50V
 DF16 × × × 310 — Plastic film capacitor
 One-way type, Mylar ±10% 50V
 ⑦ — Capacity value

Examples ;

⑦ Capacity value

0.001 μF (1000 pF) 102 0.1 μF 104
 0.0018 μF 182 0.56 μF 564
 0.01 μF 103 1 μF 105
 0.015 μF 153

NOTE : 1) The above CODES (R***, R***, C***, C*** and C***) are omitted on the schematic diagram in some case.

2) On the occasion, be confirmed the common parts on the parts list.

3) Refer to "Common Parts List" for the other common parts (R105, DD4, DK4).

NOTE ON SAFETY FOR FUSIBLE RESISTOR :

The suppliers and their type numbers of fusible resistors are as follows;

1. KOA Corporation

Part No. (MJI)	Type No. (KOA)	Description
NH05 × × × 140	RF25S × × × × ΩJ	(±5% 1/4W)
NH05 × × × 120	RF50S × × × × ΩJ	(±5% 1/2W)
NH85 × × × 110	RF73B2A × × × × ΩJ	(±5% 1/10W)
NH95 × × × 140	RF73B2E × × × × ΩJ	(±5% 1/4W)

* Resistance value Resistance value
 (0.1 Ω – 10 kΩ)

2. Matsushita Electronic Components Co., Ltd

Part No. (MJI)	Type No. (MEC)	Description
NF05 × × × 140	ERD-2FCJ × × ×	(±5% 1/4W)
RF05 × × × 140	ERD-2FCG × × ×	(±2% 1/4W)
NF02 × × × 140		
RF02 × × × 140		

* Resistance value * Resistance value

Examples ;

* Resistance value

0.1 Ω 001 10 Ω 100 1 kΩ 102 100 kΩ 104
 0.5 Ω 005 18 Ω 180 2.7 kΩ 272 680 kΩ 684
 1 Ω 010 100 Ω 101 10 kΩ 103 1 MΩ 105
 6.8 Ω 068 390 Ω 391 22 kΩ 223 4.7 MΩ 475

ABBREVIATION AND MARKS

ANT. : ANTENNA	BATT. : BATTERY
CAP. : CAPACITOR	CER. : CERAMIC
CONN. : CONNECTING	DIG. : DIGITAL
HP : HEADPHONE	MIC. : MICROPHONE
μ-PRO : MICROPROCESSOR	REC. : RECORDING
RES. : RESISTOR	SPK : SPEAKER
SW : SWITCH	TRANSF. : TRANSFORMER
TRIM. : TRIMMING	TRS. : TRANSISTOR
VAR. : VARIABLE	X'TAL : CRYSTAL

NOTE ON SAFETY :

Symbol ⚠ Fire or electrical shock hazard. Only original parts should be used to replaced any part marked with symbol ⚠ . Any other component substitution (other than original type), may increase risk of fire or electrical shock hazard.

安全上の注意 :

⚠ がついている部品は、安全上重要な部品です。必ず指定されている部品番号の部品を使用して下さい。

POS. NO	VERS. COLOR	PART NO. (FOR PCS)	DESCRIPTION	PART NO. (MJI)	POS. NO	VERS. COLOR	PART NO. (FOR PCS)	DESCRIPTION	PART NO. (MJI)
			P101-SERVO CIRCUIT BOARD						
			P101-CAPACITORS						
C101	331/340	4822 126 11669	CER. CHIP 27pF ±5%	DD95270300	R124		4822 051 30102	CHIP 1kΩ ±5% 1/16W	NN05102610
C102	331/340	4822 126 13883	CER. CHIP 220pF ±5% CG 50V	DD95221300	R125		4822 117 12902	CHIP 8.2kΩ ±5% 1/16W	NN05822610
C103		4822 126 11669	CER. CHIP 27pF ±5%	DD95270300	R126				
C104		4822 126 14417	CER. CHIP 0.01μF ±10% 50V	DK96103300	}	330/331	4822 051 30332	CHIP 3.3kΩ ±5% 1/16W	NN05332610
C105		4822 126 13837	CER. CHIP 0.1μF ±10% B 10V	DK96104200					
C106		4822 126 13837	CER. CHIP 0.1μF ±10% B 10V	DK96104200	R130	330/331	4822 051 30103	CHIP 10kΩ ±5% 1/16W	NN05103610
C107		4822 122 31765	CER. CHIP 100pF ±5% CG 50V	DD95101300	R131	330/331	4822 116 82487	CHIP 0Ω ±5% 1/16W	NN05000610
C108		4822 122 31765	CER. CHIP 100pF ±5% CG50V	DD95101300	R133	330/331	4822 051 30103	CHIP 18kΩ ±5% 1/16W	NN05103610
C109		4822 126 14417	CER. CHIP 0.01μF ±10% 50V	DK96103300	R134		4822 117 12902	CHIP 8.2kΩ ±5% 1/16W	NN05822610
C110		4822 122 33761	CER. CHIP 22pF ±5% CG 50V	DD95220300	R135		4822 116 82487	CHIP 0Ω ±5% 1/16W	NN05000610
C111			ELECT 100μF 10V	EJ10701010	R201		4822 051 30683	CHIP 68kΩ ±5% 1/16W	NN05683610
C112			ELECT 100μF 10V	EJ10701010	R202		4822 051 30683	CHIP 68kΩ ±5% 1/16W	NN05683610
C113		4822 126 13837	CER. CHIP 0.1μF ±10% B 10V	DK96104200	R203		4822 051 30272	CHIP 2.7kΩ ±5% 1/16W	NN05272610
C114			ELECT 47μF 10V	EJ47601010	R204		4822 051 30184	CHIP 180kΩ ±5% 1/16W	NN05184610
C115		4822 126 13837	CER. CHIP 0.1μF ±10% B 10V	DK96104200	R205		4822 051 30184	CHIP 180kΩ ±5% 1/16W	NN05184610
C116	330/331	4822 126 13837	CER. CHIP 0.1μF ±10% B 10V	DK96104200	R206		4822 051 30333	CHIP 33kΩ ±5% 1/16W	NN05333610
C117	330/331	4822 126 13837	CER. CHIP 0.1μF ±10% B 10V	DK96104200	R207		4822 117 12891	CHIP 220kΩ ±5% 1/16W	NN05224610
C118		4822 122 31765	CER. CHIP 100pF ±5% CG 50V	DD95101300	R208		4822 117 12891	CHIP 220kΩ ±5% 1/16W	NN05224610
C119	330		CER. CHIP 2pF ±0.25pF 50V	DD90020300	R209		4822 116 83819	CHIP 18kΩ ±5% 1/16W	NN05183610
C120		4822 126 14417	CER. CHIP 0.01μF ±10% 50V K	DK96103300	R210	330/331	4822 116 82487	CHIP 0Ω ±5% 1/16W	NN05000610
C201		5322 126 11578	CER. CHIP 1000pF ±10% B	DK96102300	R211	330/331	4822 116 82487	CHIP 0Ω ±5% 1/16W	NN05000610
C202		5322 126 11578	CER. CHIP 1000pF ±10% B	DK96102300	R212	330/331	4822 051 30472	CHIP 4.7kΩ ±5% 1/16W	NN05472610
C203			ELECT 100μF 10V	EJ10701010	R213	330/331	4822 051 30102	CHIP 1kΩ ±5% 1/16W	NN05102610
C204		4822 126 13837	CER. CHIP 0.1μF ±10% B 10V	DK96104200	R214		4822 051 30103	CHIP 10kΩ ±5% 1/16W	NN05103610
C205		4822 126 11685	CER. CHIP 4700P ±10% 50V	DK96472300	R215		4822 051 30153	CHIP 15kΩ ±5% 1/16W	NN05153610
C206	330/331	4822 126 11685	CER. CHIP 4700P ±10% 50V	DK96472300	R216		4822 051 30123	CHIP 12kΩ ±5% 1/16W	NN05123610
C207			ELECT 100μF 10V	EJ10701010	R217	331/340	4822 051 30153	CHIP 15kΩ ±5% 1/16W	NN05153610
C208		4822 126 13837	CER. CHIP 0.1μF ±10% B 10V	DK96104200	R251	340		CHIP 82Ω ±5% 1/10W	NI05820110
C209		5322 126 11578	CER. CHIP 1000pF ±10% B	DK96102300	R252	340		CHIP 82Ω ±5% 1/10W	NI05820110
C210		5322 126 11578	CER. CHIP 1000pF ±10% B	DK96102300	R253	340	4822 051 30682	CHIP 6.8kΩ ±5% 1/16W	NN05682610
C211		5322 126 11578	CER. CHIP 1000pF ±10% B	DK96102300	R254	340	4822 051 30682	CHIP 6.8kΩ ±5% 1/16W	NN05682610
C212		5322 126 11578	CER. CHIP 1000pF ±10% B	DK96102300	R255	340	4822 051 30682	CHIP 6.8kΩ ±5% 1/16W	NN05682610
C213		4822 126 11568	CER. CHIP 470pF ±10%	DK96471300	R256	340	4822 117 13632	CHIP 100kΩ ±5% 1/16W	NN05104610
C214			CER. CHIP 0.22μF ±10% B 16V	DK56224200	R257	340	4822 051 30103	CHIP 10kΩ ±5% 1/16W	NN05103610
C215	330/331	4822 126 11568	CER. CHIP 470pF ±10%	DK96471300	R258	340	4822 051 30103	CHIP 10kΩ ±5% 1/16W	NN05103610
C216		4822 126 14417	CER. CHIP 0.01μF ±10% 50V K	DK96103300	R259	340		CHIP 2.2Ω ±5% 1/10W	NI05022110
C217			CER. CHIP 0.47μF ±10% 16V B	DK56474200	R260	340		CHIP 2.2Ω ±5% 1/10W	NI05022110
C218	331	4822 126 13837	CER. CHIP 0.1μF ±10% B 10V	DK96104200	R261	340		CHIP 2.2Ω ±5% 1/10W	NI05022110
C251	340	4822 126 13837	CER. CHIP 0.1μF ±10% B 10V	DK96104200	R262	340	4822 051 30223	CHIP 22kΩ ±5% 1/16W	NN05223610
C252	340	4822 126 13837	CER. CHIP 0.1μF ±10% B 10V	DK96104200	R263	340	4822 051 30223	CHIP 22kΩ ±5% 1/16W	NN05223610
C253	340	4822 126 13837	CER. CHIP 0.1μF ±10% B 10V	DK96104200	R264	340	4822 051 30223	CHIP 22kΩ ±5% 1/16W	NN05223610
C254	340		ELECT 100μF 10V	EJ10701010	R265	340	4822 116 82487	CHIP 0Ω ±5% 1/16W	NN05000610
C255	340	4822 126 13837	CER. CHIP 0.1μF ±10% B 10V	DK96104200	R266	340		CHIP 2.2Ω ±5% 1/10W	NI05022110
C256	340	4822 126 13837	CER. CHIP 0.1μF ±10% B 10V	DK96104200				P101-SEMICONDUCTORS	
C257	340	4822 126 13837	CER. CHIP 0.1μF ±10% B 10V	DK96104200	Q101	330/331	9965 000 01600	IC TZA1022 HF AMP/LA CONT	HC10180490
C258	340	4822 126 13396	CER. CHIP 0.047μF ±10% 16V	DK96473200	Q102		9965 000 01720	IC NJM2137M-TE1 DUAL OP	HC10206090
R101		4822 051 30681	CHIP 680Ω ±5% 1/16W	NN05681610	Q103		4822 209 30455	IC NJM2100M JRC	HC10085090
R102		4822 051 30681	CHIP 680Ω ±5% 1/16W	NN05681610	Q104		4822 130 61906	DIG. TRS. DTC114EU	BA20035210
R103		4822 051 30223	CHIP 22kΩ ±5% 1/16W	NN05223610	Q105		4822 130 61906	DIG. TRS. DTC114EU	BA20035210
R104		4822 051 30223	CHIP 22kΩ ±5% 1/16W	NN05223610	Q106		4822 130 60731	CHIP TRS. 2SA1036K Q R	HX110362B0
R105		4822 117 12925	CHIP 47kΩ ±5% 1/16W	NN05473610	Q107		4822 130 61906	DIG. TRS. DTC114EU	BA20035210
R106		4822 051 30153	CHIP 15kΩ ±5% 1/16W	NN05153610	Q108		4822 130 11357	DIG. TRS. RN2307 DTA114YU	BA12307000
R107		4822 051 30102	CHIP 1kΩ ±5% 1/16W	NN05102610	Q109		9965 000 01601	THERMISTOR	HH50005780
R108		4822 051 30152	CHIP 1.5kΩ ±5% 1/16W	NN05152610	Q110	331/340	4822 130 61906	DIG. TRS. DTC114EU	BA20035210
R109		4822 051 30474	CHIP 470kΩ ±5% 1/16W	NN05474610	Q112	340	9965 000 01601	THERMISTOR	HH50005780
R110		4822 051 30103	CHIP 10kΩ ±5% 1/16W	NN05103610	Q201		4822 209 16372	IC TDA7073AT	HC10165490
R111		4822 051 30333	CHIP 33kΩ ±5% 1/16W	NN05333610	Q202		4822 209 16372	SOP DUAL BTL DRIVER	HC10165490
R112		4822 051 30333	CHIP 33kΩ ±5% 1/16W	NN05333610	Q203	331/340	9965 000 01601	IC TDA7073AT	HC10165490
R113		4822 051 30562	CHIP 5.6kΩ ±5% 1/16W	NN05562610	Q251	340	4822 209 16877	SOP DUAL BTL DRIVER	HC10165490
R114		4822 116 82487	CHIP 0Ω ±5% 1/16W	NN05000610	Q203	331/340	9965 000 01601	THERMISTOR	HH50005780
R116		4822 117 12891	CHIP 220kΩ ±5% 1/16W	NN05224610	Q252	340	4822 130 60731	TN10-4C103JT 10k	HH50005780
R117		4822 051 30102	CHIP 1kΩ ±5% 1/16W	NN05102610	Q251	340	4822 209 16877	IC BA6856FP	HC10213210
R118		4822 051 30102	CHIP 1kΩ ±5% 1/16W	NN05102610	Q252	340	4822 130 60731	3PH-MOTOR DRIVER	HC10213210
R121		4822 117 13632	CHIP 100kΩ ±5% 1/16W	NN05104610				CHIP TRS. 2SA1036K Q R	HX110362B0
R123		4822 117 13632	CHIP 100kΩ ±5% 1/16W	NN05104610					

POS. NO	VERS. COLOR	PART NO. (FOR PCS)	DESCRIPTION	PART NO. (MJI)	POS. NO	VERS. COLOR	PART NO. (FOR PCS)	DESCRIPTION	PART NO. (MJI)
J101			P101-MISCELLANEOUS		CD10		9965 000 00599	CER. CHIP 0.22µF ±10% B 10V	DK96224200
J102			JACK 16FMZ-ST FFC CONN.	YJ07020820	CD11		9965 000 00599	CER. CHIP 0.22µF ±10% B 10V	DK96224200
J202			JACK 20FE-ST-VK-N 20PIN	YJ07020160	CD12		4822 126 13837	CER. CHIP 0.1µF ±10% B 10V	DK96104200
			JACK 11FM-1.0ST FFC CONN.	YJ07020830	CD13		4822 122 32672	TANTL.CHIP 1µF 16V	EY10501610
▲ L801	/F, /U		P801-TRANS CIRCUIT BOARD		CD14		5322 124 41744	ELECT. 4700µF 10V RA-2	OA47801020
			MAINS TRANSF. EI-57	TS15747010	CD15		4822 126 13689	CER. CHIP 18pF ±5%	DD95180300
▲ L801	/N	9965 000 01599	100V/120V		CD16		4822 122 33752	CER. CHIP 15pF ±5% CG 50V	DD95150300
			MAINS TRANSF. EI-57 230V	TS15747020	CD17		4822 126 13837	CER. CHIP 0.1µF ±10% B 10V	DK96104200
▲ C851		4822 122 33276	P851-POWER SW		CD18		4822 126 13396	CER. CHIP 0.047µF ±10% X7R	DK96473200
▲ L851		4822 157 70419	CIRCUIT BOARD		CD19	330	4822 126 11671	CER. CHIP 33pF ±5% CG 50V	DD95330300
▲ S851		4822 276 13364	CER. DE7150 F 103M VA1 KC	DK17103840	CD19	331/340	5322 126 14449	CER. CHIP 39pF ±5% CG 50V	DD95390300
			LF-4D-102	FN01020020	CD20		4822 122 33753	CER. CHIP 150pF ±5% CG 50V	DD95151300
			PUSH SWITCH SDDL1	SP01011990	CD21	330	4822 126 13689	CER. CHIP 18pF ±5% CG 50V	DD95180300
			POWER TV-3		CD22	331/340	5322 126 11578	CER. CHIP 1000pF ±10% B	DK96102300
					CD23	331/340	4822 122 31765	CER. CHIP 100pF ±5% CG 50V	DD95101300
					CM01		5322 122 32654	CER. CHIP 0.022µF ±10% 16V	DK96223200
			PB01-XLR CONN. CIRCUIT BOARD [PMD331/340]		CT01		4822 126 13837	CER. CHIP 0.1µF ±10% B 10V	DK96104200
			PB01-CAPACITORS		CT03		4822 126 12339	CER. CHIP 2200P ±10% 50V	DK96223000
CT52	331/340	4822 124 41537	ELECT. 220µF M 6.3V RA-2	OA22700620	CT04		4822 126 13837	CER. CHIP 0.1µF ±10% B 10V	DK96104200
CT53	331/340		CER. 50V DC 0.1µF +80 -20%	DD38104010	CT07	331/340	4822 126 13837	CER. CHIP 0.1µF ±10% B 10V	DK96104200
CT56	331/340		CER. 0.01µF ±10% 50V	DK16103300	CT08	331/340	4822 124 22275	ELECT. 47µF M 10V RA-2	OA47601020
CT57	331/340		CER. 0.01µF ±10% 50V	DK16103300	CU01		4822 122 33752	CER. CHIP 15pF ±5% CG 50V	DD95150300
CT58	331/340		CER. 220pF ±10% 50V	DK16221300	CU02		4822 122 33752	CER. CHIP 15pF ±5% CG 50V	DD95150300
CT59	331/340		CER. 220pF ±10% 50V	DK16221300	CU03		4822 126 13837	CER. CHIP 0.1µF ±10% B 10V	DK96104200
					CU04		4822 126 13837	CER. CHIP 0.1µF ±10% B 10V	DK96104200
					CU05		4822 124 41543	ELECT. 1µF M 50V RA-2	OA10505020
RT52	331/340		PB01-RESISTORS		CU41		4822 126 13837	CER. CHIP 0.1µF ±10% B 10V	DK96104200
RT53	331/340		56Ω ±5% 1/6W	GG05560160	CU51		4822 124 90352	ELECT. 10µF M 16V RA-2	OA10601620
			56Ω ±5% 1/6W	GG05560160	CU53		4822 126 13837	CER. CHIP 0.1µF ±10% B 10V	DK96104200
					CU54	331/340	5322 126 11578	CER. CHIP 1000pF ±10% B	DK96102300
					CU60		5322 126 11578	CER. CHIP 1000pF ±10% B	DK96102300
QT52	331/340	5322 209 60473	PB01-SEMICONDUCTOR		CU79	331/340	4822 126 13837	CER. CHIP 0.1µF ±10% B 10V	DK96104200
			IC SN75158/P TEXAS INST.	HC10071370	CU80	331/340	4822 126 13837	CER. CHIP 0.1µF ±10% B 10V	DK96104200
					CU91		4822 126 13837	CER. CHIP 0.1µF ±10% B 10V	DK96104200
					C301	331/340	4822 124 90352	ELECT. 10µF M 16V RA-2	OA10601620
JB53	331/340		PB01-MISCELLANEOUS		C302	331/340	4822 126 13837	CER. CHIP 0.1µF ±10% B 10V	DK96104200
JB54	331/340		JACK NC3MAH 3P CANNON	YJ01004070	C303	331/340	4822 126 13837	CER. CHIP 0.1µF ±10% B 10V	DK96104200
JT53	331/340		JACK NC3MAH 3P CANNON	YJ01004070	C304	331/340	4822 126 13837	CER. CHIP 0.1µF ±10% B 10V	DK96104200
			JACK NC3MAH 3P CANNON	YJ01004070	C305	331/340	4822 126 13396	CER. CHIP 0.047µF ±10% X7R	DK96473200
LT52	331/340	4822 242 73843	EMI FILTER DSS306-91-F-2232	FM12223010	C501		4822 124 90352	ELECT. 10µF M 16V RA-2	OA10601620
LT53	331/340	4822 148 81381	PULSE TRANSF. TC-1086-26	TP33842010	C502		4822 124 90352	ELECT. 10µF M 16V RA-2	OA10601620
LT54	331/340		FERRITE CORE	FC90050040	C503		4822 122 33761	CER. CHIP 22pF ±5% CG 50V	DD95220300
			BL02RN1-R62T2		C504		4822 122 33761	CER. CHIP 22pF ±5% CG 50V	DD95220300
LT55	331/340		FERRITE CORE	FC90050040	C505		4822 122 33753	CER. CHIP 150pF ±5% 50V	DD95151300
			BL02RN1-R62T2		C506		4822 122 33753	CER. CHIP 150pF ±5% 50V	DD95151300
					C507		4822 122 33753	CER. CHIP 150pF ±5% 50V	DD95151300
					C508		4822 122 33753	CER. CHIP 150pF ±5% 50V	DD95151300
					C509		4822 124 90354	ELECT. 100µF M 16V RA-2	OA10701620
					C510		4822 124 90354	ELECT. 100µF M 16V RA-2	OA10701620
					C511		5322 126 11578	CER. CHIP 1000pF ±10% B	DK96102300
					C512		5322 126 11578	CER. CHIP 1000pF ±10% B	DK96102300
					C513		4822 126 13837	CER. CHIP 0.1µF ±10% B 10V	DK96104200
					C514		4822 126 13837	CER. CHIP 0.1µF ±10% B 10V	DK96104200
					C515		4822 126 13837	CER. CHIP 0.1µF ±10% B 10V	DK96104200
					C516		4822 124 90352	ELECT. 10µF M 16V RA-2	OA10601620
					C517		4822 126 13837	CER. CHIP 0.1µF ±10% B 10V	DK96104200
					C518		4822 126 13837	CER. CHIP 0.1µF ±10% B 10V	DK96104200
					}		4822 124 90352	ELECT. 10µF M 16V RA-2	OA10601620
					C522		4822 124 90354	ELECT. 100µF M 16V RA-2	OA10701620
					C523		4822 124 90354	ELECT. 100µF M 16V RA-2	OA10701620
					C524		4822 124 90354	ELECT. 100µF M 16V RA-2	OA10701620
					C525		4822 126 13837	CER. CHIP 0.1µF ±10% B 10V	DK96104200
					C526		4822 126 13837	CER. CHIP 0.1µF ±10% B 10V	DK96104200
					C541	331/340	4822 126 13837	CER. CHIP 0.1µF ±10% B 10V	DK96104200
CD01	330/331	4822 126 11685	CER. CHIP 4700pF ±10% B 50V	DK96472300					
CD01	340	4822 126	CER. CHIP 3300pF ±10% B 50V	DK96332300					
CD02		4822 126 13396	CER. CHIP 0.047µF ±10% X7R	DK96473200					
CD03		5322 126 11578	CER. CHIP 1000pF ±10% B	DK96102300					
CD04		5322 126 11578	CER. CHIP 1000pF ±10% B	DK96102300					
CD05		4822 126 14417	CER. CHIP 0.01µF ±10% 50V K	DK96103300					
CD06			CER. CHIP 0.47µF ±10% 16V B	DK56474200					
CD07		4822 126 13396	CER. CHIP 0.047µF ±10% X7R	DK96473200					
CD08		4822 126 12495	CER. CHIP 1500P ±10% 50V	DK96152300					
CD09		5322 126 11578	CER. CHIP 1000P ±10% 50V	DK96102300					

POS. NO	VERS. COLOR	PART NO. (FOR PCS)	DESCRIPTION	PART NO. (MJ)	POS. NO	VERS. COLOR	PART NO. (FOR PCS)	DESCRIPTION	PART NO. (MJ)
C801	330	4822 124 22243	ELECT 6800µF 16V RE3	OA68801620	RT03		4822 051 30331	CHIP 330Ω ±5% 1/16W	NN05331610
C801	331/340		ELECT 10000µF 16V RE3	EA10901670	RT04		4822 051 30759	CHIP 75Ω ±5% 1/16W	NN05750610
C802			CER. 0.1µF +80%-20% 50V	DD38104010					
C803			CER. 0.1µF +80%-20% 50V	DD38104010	RU01		4822 051 30103	CHIP 10kΩ ±5% 1/16W	NN05103610
C804		4822 124 90371	ELECT. 470µF M 10V RA-2	OA47701020	RU02		4822 051 30103	CHIP 10kΩ ±5% 1/16W	NN05103610
C805			CER. 0.1µF +80%-20% 50V	DD38104010	RU04		4822 051 30474	CHIP 470kΩ ±5% 1/16W	NN05474610
C806			CER. 0.1µF +80%-20% 50V	DD38104010	RU05	330/331	4822 116 82487	CHIP 0Ω ±5% 1/16W	NN05000610
C807		4822 124 90371	ELECT. 470µF M 10V RA-2	OA47701020	RU06		4822 051 30474	CHIP 470kΩ ±5% 1/16W	NN05474610
C808		4822 124 11583	ELECT. 2200µF M 35V RA-2	OA22803520	RU07		4822 051 30474	CHIP 470kΩ ±5% 1/16W	NN05474610
C809		4822 124 11583	ELECT. 2200µF M 35V RA-2	OA22803520	RU08		4822 051 30474	CHIP 470kΩ ±5% 1/16W	NN05474610
C810			CER. 0.1µF +80%-20% 50V	DD38104010	RU09		4822 051 30103	CHIP 10kΩ ±5% 1/16W	NN05103610
C811			CER. 0.1µF +80%-20% 50V	DD38104010	RU10	330/340	4822 116 82487	CHIP 0Ω ±5% 1/16W	NN05000610
C812			CER. 0.1µF +80%-20% 50V	DD38104010	RU11				
C813			CER. 0.1µF +80%-20% 50V	DD38104010	RU11				
C814		4822 124 22277	ELECT. 470µF 16V M RA-2	OA47701620	RU21		4822 051 30103	CHIP 10kΩ ±5% 1/16W	NN05103610
C815		4822 124 22277	ELECT. 470µF 16V M RA-2	OA47701620	RU22		4822 051 30474	CHIP 470kΩ ±5% 1/16W	NN05474610
C816		4822 124 41543	ELECT. 1µF M 50V RA-2	OA10505020	RU23				
			PD01-RESISTORS		RU23				
RB01	331/340	9965 000 01716	VARIABLE 10kΩ B	RK01031580	RU27		4822 051 30103	CHIP 10kΩ ±5% 1/16W	NN05103610
RB02	331/340	9965 000 01716	VARIABLE 10kΩ B	RK01031580	RU28		4822 051 30474	CHIP 470kΩ ±5% 1/16W	NN05474610
RB03	331/340	4822 051 30221	CHIP 220Ω ±5% 1/16W	NN05221610	RU30		4822 051 30105	CHIP 1MΩ ±5% 1/16W	NN05105610
RB04	331/340	4822 051 30221	CHIP 220Ω ±5% 1/16W	NN05221610	RU31		4822 051 30474	CHIP 470kΩ ±5% 1/16W	NN05474610
RB05	331/340	4822 051 30103	CHIP 10kΩ ±5% 1/16W	NN05103610	RU32	330	4822 051 30103	CHIP 10kΩ ±5% 1/16W	NN05103610
RB06	331/340	4822 051 30103	CHIP 10kΩ ±5% 1/16W	NN05103610	RU41		4822 051 30472	CHIP 4.7kΩ ±5% 1/16W	NN05472610
RB07	331/340	4822 051 30682	CHIP 6.8kΩ ±5% 1/16W	NN05682610	RU42		4822 051 30472	CHIP 4.7kΩ ±5% 1/16W	NN05472610
RB08	331/340	4822 051 30682	CHIP 6.8kΩ ±5% 1/16W	NN05682610	RU51		4822 116 82487	CHIP 0Ω ±5% 1/16W	NN05000610
RB09	331/340	4822 051 30223	CHIP 22kΩ ±5% 1/16W	NN05223610	RU52		4822 117 12925	CHIP 47kΩ ±5% 1/16W	NN05473610
RB10	331/340	4822 051 30223	CHIP 22kΩ ±5% 1/16W	NN05223610	RU53		4822 116 83819	CHIP 18kΩ ±5% 1/16W	NN05183610
RB11	331/340	4822 051 30223	CHIP 22kΩ ±5% 1/16W	NN05223610	RU54		4822 051 30479	CHIP 47kΩ ±5% 1/16W	NN05470610
RB12	331/340	4822 051 30223	CHIP 22kΩ ±5% 1/16W	NN05223610	RU55		4822 051 30102	CHIP 1kΩ ±5% 1/16W	NN05102610
RB13					RU58		4822 051 30103	CHIP 10kΩ ±5% 1/16W	NN05103610
RB13					RU60	331/340	4822 051 30102	CHIP 1kΩ ±5% 1/16W	NN05102610
RB24					RU62				
RB25					RU62	331/340	4822 051 30102	CHIP 1kΩ ±5% 1/16W	NN05102610
RB25					RU74				
RB28					RU80				
RB29					RU80	331/340	4822 117 12925	CHIP 47kΩ ±5% 1/16W	NN05473610
RB32					RU90				
RB33					RU91		4822 051 30474	CHIP 470kΩ ±5% 1/16W	NN05474610
RB36					RU92		4822 051 30474	CHIP 470kΩ ±5% 1/16W	NN05474610
					RU93	331/340	4822 117 12925	CHIP 47kΩ ±5% 1/16W	NN05473610
					RU94	331/340	4822 117 12925	CHIP 47kΩ ±5% 1/16W	NN05473610
					RU95	331/340	4822 117 12925	CHIP 47kΩ ±5% 1/16W	NN05473610
RD01		4822 051 30222	CHIP 2.2kΩ ±5% 1/16W	NN05222610	R301	331/340	4822 051 30474	CHIP 470kΩ ±5% 1/16W	NN05474610
RD02		4822 051 30153	CHIP 15kΩ ±5% 1/16W	NN05153610	R501		4822 051 30103	CHIP 10kΩ ±5% 1/16W	NN05103610
RD03		4822 051 30153	CHIP 15kΩ ±5% 1/16W	NN05153610	R502		4822 051 30103	CHIP 10kΩ ±5% 1/16W	NN05103610
RD04		4822 051 30474	CHIP 470kΩ ±5% 1/16W	NN05474610	R503		4822 051 30472	CHIP 4.7kΩ ±5% 1/16W	NN05472610
RD05		4822 051 30103	CHIP 10kΩ ±5% 1/16W	NN05103610	R504		4822 051 30472	CHIP 4.7kΩ ±5% 1/16W	NN05472610
RD06		4822 117 13632	CHIP 100kΩ ±5% 1/16W	NN05104610	R505		4822 116 83819	CHIP 18kΩ ±5% 1/16W	NN05183610
RD07		4822 051 30332	CHIP 3.3kΩ ±5% 1/16W	NN05332610	R506		4822 116 83819	CHIP 18kΩ ±5% 1/16W	NN05183610
RD08		4822 051 30332	CHIP 3.3kΩ ±5% 1/16W	NN05332610	R507		4822 051 30333	CHIP 33kΩ ±5% 1/16W	NN05333610
RD09		4822 051 30103	CHIP 10kΩ ±5% 1/16W	NN05103610	R508		4822 051 30333	CHIP 33kΩ ±5% 1/16W	NN05333610
RD10		4822 051 30105	CHIP 1MΩ ±5% 1/16W	NN05105610	R509		4822 051 30123	CHIP 12kΩ ±5% 1/16W	NN05123610
RD11		4822 051 30223	CHIP 22kΩ ±5% 1/16W	NN05223610	R510		4822 051 30123	CHIP 12kΩ ±5% 1/16W	NN05123610
RD12		4822 117 12925	CHIP 47kΩ ±5% 1/16W	NN05473610	R511		4822 051 30103	CHIP 10kΩ ±5% 1/16W	NN05103610
RD13		4822 051 30333	CHIP 33kΩ ±5% 1/16W	NN05333610	R512		4822 051 30103	CHIP 10kΩ ±5% 1/16W	NN05103610
RD15		4822 051 30474	CHIP 470kΩ ±5% 1/16W	NN05474610	R513		4822 051 30223	CHIP 22kΩ ±5% 1/16W	NN05223610
RD16		4822 051 30103	CHIP 10kΩ ±5% 1/16W	NN05103610	R514		4822 051 30223	CHIP 22kΩ ±5% 1/16W	NN05223610
RD17		4822 051 30103	CHIP 10kΩ ±5% 1/16W	NN05103610	R515		4822 051 30151	CHIP 150Ω ±5% 1/16W	NN05151610
RD18		4822 051 30103	CHIP 10kΩ ±5% 1/16W	NN05103610	R516		4822 051 30151	CHIP 150Ω ±5% 1/16W	NN05151610
RD19		4822 051 30103	CHIP 10kΩ ±5% 1/16W	NN05103610	R517		4822 117 12925	CHIP 47kΩ ±5% 1/16W	NN05473610
RD20		4822 051 30102	CHIP 1kΩ ±5% 1/16W	NN05102610	R518		4822 117 12925	CHIP 47kΩ ±5% 1/16W	NN05473610
RD22		4822 116 82487	CHIP 0Ω ±5% 1/16W	NN05000610	R519		4822 051 30471	CHIP 470Ω ±5% 1/16W	NN05471610
RD23	331	4822 116 83819	CHIP 18kΩ ±5% 1/16W	NN05183610	R520		4822 051 30471	CHIP 470Ω ±5% 1/16W	NN05471610
RD23	340	4822 051 30153	CHIP 15kΩ ±5% 1/16W	NN05153610	R531	330	4822 116 82487	CHIP 0Ω ±5% 1/16W	NN05000610
▲ RM01		4822 111 90967	FUSE 4.7Ω J 1/4W	NF05047140	R532	330	4822 116 82487	CHIP 0Ω ±5% 1/16W	NN05000610
RM02		4822 051 30681	CHIP 680Ω ±5% 1/16W	NN05681610	R533	330	4822 116 82487	CHIP 0Ω ±5% 1/16W	NN05000610
RT02		4822 051 30221	CHIP 220Ω ±5% 1/16W	NN05221610	R541	331/340	4822 117 13632	CHIP 100kΩ ±5% 1/16W	NN05104610
					R542	331/340	4822 051 30222	CHIP 2.2kΩ ±5% 1/16W	NN05222610

POS. NO	VERS. COLOR	PART NO. (FOR PCS)	DESCRIPTION	PART NO. (MJI)	POS. NO	VERS. COLOR	PART NO. (FOR PCS)	DESCRIPTION	PART NO. (MJI)
R543	331/340	4822 051 30222	CHIP 2.2kΩ ±5% 1/16W	NN05222610				PD01-MISCELLANEOUS	
R544	331/340	4822 051 30102	CHIP 1kΩ ±5% 1/16W	NN05102610	JD01			JACK 20FE-BT-VK-N 20PIN	YJ07020530
R801					JT01		4822 267 31729	TERMINAL 14X14 RA 1L1P BLK	YT02010780
R805		4822 051 30472	CHIP 4.7kΩ ±5% 1/16W	NN05472610	JT02	331/340	4822 267 31369	OPT. CONN.GP1F32T	YJ15000090
								OPTICAL OUTPUT	
					JU01			JACK 30PIN 30FMN-BMTTR-TB	YJ07016500
					JU51			TERMINAL RCA JACK ORG	YT02021090
DB01	331/340	4822 130 83715	CHIP DIODE 1SS301 DAN202U	HZ21005000	JU53	331/340	4822 265 11401	PLUG D-SUB 25P FEMALE	YP11000180
DB02	331/340	4822 130 83715	CHIP DIODE 1SS301 DAN202U	HZ21005000	J501		4822 267 31727	TERMINAL 14X14 RCA 2L2P	YT02021210
DM02		9965 000 01598	CHIP DIODE	HZ30821000					
			UDZS8.2B MA8082-M		LB01	331/340	9965 000 01343	RELAY RELAY MR62-12SR	LY20120510
DU01		9965 000 01491	CHIP DIODE DA227	HZ20032210	LB02	331/340	9965 000 01343	RELAY RELAY MR62-12SR	LY20120510
DU02		9965 000 01491	ARRAY 2PIECES-2125		LD01			CHIP INDUCTANCE	LU04472010
			ARRAY 2PIECES-2125					4.7μH ±10% 1608 TYPE	
DU03		4822 130 83715	CHIP DIODE 1SS301 DAN202U	HZ21005000	LD02			CHIP INDUCTANCE	LU04472010
DU51		4822 130 83715	CHIP DIODE 1SS301 DAN202U	HZ21005000				4.7μH ±10% 1608 TYPE	
DU52		4822 130 83715	CHIP DIODE 1SS301 DAN202U	HZ21005000	LD03			CHIP INDUCTANCE	LU04471010
D501		4822 130 83715	CHIP DIODE 1SS301 DAN202U	HZ21005000				0.47μH ±10% MLF1608	
D502		4822 130 81324	CHIP DIODE 1SS302	HZ20018050	LD04			CHIP INDUCTANCE	LU04471010
▲ D801		4822 130 83067	DIODE D3SB 20	HE20020290	LT01		4822 142 60388	0.47μH ±10% MLF1608	
			V=200V IO=3.0A		LT02			PULSE TRANSF. FOR CD	TP41042010
▲ D802		4822 130 10413	DIODE BRIDGE D2SBA20	HE20027290				FERRIT BEADS	FC90020120
D803		4822 130 83715	CHIP DIODE 1SS301 DAN202U	HZ21005000	LT03	331/340		BK1608HM102-T	FC90020120
								FERRIT BEADS	
								BK1608HM102-T	
					L501		9965 000 01343	RELAY MR62-12SR	LY20120510
QB01									
QB04	331/340	4822 209 83357	IC NJM4560M JRC	HC10029090	SU51		4822 277 21789	SLIDE SWITCH SSSUI-6MM	SS02020970
QD01					XD01		4822 242 10883	CRYSTAL CM309S	JX16002360
QD02	331/340	9965 000 01437	IC CXD2585Q CD DECODER	HC10069250				16.9344MHz CITIZEN	
		9965 000 01601	THERMISTOR	HH50005780	XU01		9965 000 01597	CRYSTAL CM309S 20MHz	JX20001360
			TN10-4C103JT 10k						
QM01		4822 209 30193	IC LB1641 MOTOR DRIVER	HC10279030				PV01-HEAD PHONE	
QU01		9965 000 01492	MICROPROCESSOR	HU371KH00F				CIRCUIT BOARD	
			HD643306ZF MPU					PV01-CAPACITORS	
QU03		9965 000 01595	IC AT25640	HC10074990	CV01			ELECT 100μF 16V RC-2	EJ10701610
			64K EEPROM		CV02			ELECT 100μF 16V RC-2	EJ10701610
QU04		9965 000 01596	IC 74HC4094BT FLAT	HC809449R0	CV03			ELECT 47μF 16V	EJ47601610
QU41		4822 130 60731	CHIP TRS. 2SA1036K Q R	HX110362B0	CV04			ELECT 47μF 16V	EJ47601610
QU42		4822 130 61906	DIG.TRS. DTC114EU	BA20035210					
QU51		4822 130 60669	CHIP TRS. 2SC4081 Q R	HX300012A0				PV01-RESISTORS	
			2SC4116 Y GR					CHIP 15kΩ ±5% 1/16W	NN05153610
QU52		4822 130 61906	DIG.TRS. DTC114EU	BA20035210	RV01		4822 051 30153	CHIP 15kΩ ±5% 1/16W	NN05153610
QU53		4822 130 11357	DIG.TRS. RN2307 DTA114YU	BA12307000	RV02		4822 051 30153	CHIP 10kΩ ±5% 1/16W	NN05103610
QU55		4822 130 11357	DIG.TRS. RN2307 DTA114YU	BA12307000	RV03		4822 051 30103	CHIP 10kΩ ±5% 1/16W	NN05103610
QU56		9965 000 01596	IC 74HC4094BT FLAT	HC809449R0	RV04		4822 051 30103	CHIP 10kΩ ±5% 1/16W	NN05103610
QU57		4822 209 17428	IC 74HC165F	HC716500R0	RV05		9965 000 01489	CHIP 120Ω ±5% 1/2W	RI05121120
QU58		4822 209 17428	IC 74HC165F	HC716500R0	RV06		9965 000 01489	CHIP 120Ω ±5% 1/2W	RI05121120
QU59					RV07		4822 051 30472	CHIP 4.7kΩ ±5% 1/16W	NN05472610
QU64		4822 130 61906	DIG.TRS. DTC114EU	BA20035210	RV08		4822 051 30472	CHIP 4.7kΩ ±5% 1/16W	NN05472610
QU91		4822 209 30426	IC CMOS 74HC00 FLAT	HC700000Z0	RV09		9965 000 01490	VARIABLE 50kΩ A L=15MM	RM05033070
Q301	331/340	9965 000 01717	IC RL5C357 SHOCK PROOF	HC10042770				PV01-SEMICONDUCTOR	
Q302	331/340	9965 000 01718	IC HY5117400BJ-60 DRAM	HC10089990	QV01		4822 209 31378	IC NJM4556AM JRC	HC10045090
Q501		4822 209 15226	IC PCM1710U 16/20BIT DAC	HC10004610				PV01-MISCELLANEOU	
Q502		4822 209 83357	IC NJM4560 FLAT PACK JRC	HC10029090	JV02		4822 267 31126	JACK ST HEADPHONE BL/GL	YJ01003020
Q541	331/340	4822 130 11357	DIG.TRS. RN2307 DTA114YU	BA12307000				PY01-DISPLAY	
Q542	331/340	4822 130 43818	TRS. 2SC2878 A OR B	HT328782A0				CIRCUIT BOARD	
Q543	331/340	4822 130 43818	TRS. 2SC2878 A OR B	HT328782A0				PY01-CAPACITORS	
▲ Q801		4822 209 83824	IC NJM7805FA +5V 1A JRC	HC38905090	CY01		9965 000 01438	TANTL.CHIP 2.2μF 50V	EY22505020
▲ Q802		4822 209 73674	IC NJM7806FA +6V 1A JRC	HC38906090	CY02		9965 000 01438	TANTL.CHIP 2.2μF 50V	EY22505020
▲ Q803		4822 209 82829	IC NJM78M15FA +15V 0.5A	HC38515090	CY03		9965 000 01438	TANTL.CHIP 2.2μF 50V	EY22505020
▲ Q804		4822 209 83828	IC NJM79M15FA -15V 0.5A	HC39515090	CY04		4822 124 23002	TANTL.CHIP 10μF 16V	EY10601620
Q805		4822 130 61906	DIG.TRS. DTC114EU	BA20035210	CY05		4822 126 14417	CER. CHIP 0.01μF ±10% 50V K	DK96103300
Q806		4822 130 61906	DIG.TRS. DTC114EU	BA20035210	CY06		4822 124 11226	TANTL.CHIP 22μF 6.3V	EY22600620
					CY07		4822 126 14417	CER. CHIP 0.01μF ±10% 50V K	DK96103300
					CY08		4822 126 14417	CER. CHIP 0.01μF ±10% 50V K	DK96103300
					CY09		4822 126 14417	CER. CHIP 0.01μF ±10% 50V K	DK96103300

POS. NO	VERS. COLOR	PART NO. (FOR PCS)	DESCRIPTION	PART NO. (MJI)
CY10 }		5322 126 11578	CER. CHIP 1000pF ±10% B	DK96102300
CY17				
			PY01-RESISTORS	
RY01		9965 000 01444	VARIABLE 100kΩ B W/CLIC	RB01040080
RY02		4822 051 30332	CHIP 3.3kΩ ±5% 1/16W	NN05332610
RY03		4822 051 30103	CHIP 10kΩ ±5% 1/16W	NN05103610
RY04		4822 051 30103	CHIP 10kΩ ±5% 1/16W	NN05103610
RY05		4822 051 30273	CHIP 27kΩ ±5% 1/16W	NN05273610
RY06		4822 051 30103	CHIP 10kΩ ±5% 1/16W	NN05103610
RY07		4822 051 30103	CHIP 10kΩ ±5% 1/16W	NN05103610
RY08		4822 117 12864	CHIP 82kΩ ±5% 1/16W	NN05823610
RY09		4822 051 30101	CHIP 100Ω ±5% 1/16W	NN05101610
RY11		4822 051 30101	CHIP 100Ω ±5% 1/16W	NN05101610
RY12		4822 051 30101	CHIP 100Ω ±5% 1/16W	NN05101610
RY13		4822 051 30121	CHIP 120Ω ±5% 1/16W	NN05121610
RY14		4822 051 30121	CHIP 120Ω ±5% 1/16W	NN05121610
RY15		4822 051 30121	CHIP 120Ω ±5% 1/16W	NN05121610
RY16		4822 051 30121	CHIP 120Ω ±5% 1/16W	NN05121610
RY17		4822 051 30101	CHIP 100Ω ±5% 1/16W	NN05101610
RY18		4822 117 12891	CHIP 220kΩ ±5% 1/16W	NN05224610
RY19		4822 051 30121	CHIP 120Ω ±5% 1/16W	NN05121610
RY20		4822 051 30221	CHIP 220Ω ±5% 1/16W	NN05221610
			PY01-SEMICONDUCTORS	
DY01 }		9965 000 01439	L.E.D. FY1101F-TX	HI10010300
DY06			YELLOW CHIP	
DY07		9965 000 01440	L.E.D. SML-310DT	HI10103210
			ORANGE CHIP	
DY08		9965 000 01440	L.E.D. SML-310DT	HI10103210
			ORANGE CHIP	
DY09 }		9965 000 01441	L.E.D. SML-310MT	HI10104210
DY12			GREEN CHIP	
DY13 }		9965 000 01440	L.E.D. SML-310DT	HI10103210
DY18			ORANGE CHIP	
QY01		9965 000 01442	IC HD66712SA02FS LCD DRIV.	HC10132010
QY02		4822 130 60669	CHIP TRS. 2SC4081 Q R	HX300012A0
			2SC4116 Y GR	
QY05		9965 000 01443	DISPLAY UNIT LCD	HQ22801800
QY06		4822 130 61906	DIG. TRS. DTC114EU	BA20035210
QY07		4822 130 61906	DIG. TRS. DTC114EU	BA20035210
QY08		4822 130 61906	DIG. TRS. DTC114EU	BA20035210
QY09		4822 130 61906	DIG. TRS. DTC114EU	BA20035210
			PY01MISCELLANEOUS	
JY01			JACK 30PIN 30FMN-BMTTR-TB	YJ07016500
JY03			JUMPER LEAD ZEBRA CONN.	YU01009700
SY14 }		9965 000 01445	TACT SWITCH SKHMPW	SP01013320
SY28				
			PY41-IR SENSOR	
QY41		4822 130 10161	CIRCUIT BOARD PHOTO UNIT SPS-446-4	HW10005030
			IR SENSOR SANYO	
			PY51-PITCH DIAL CIRCUIT	
SY51	331/340	9965 000 01719	BOARD FOR PMD331/340 ROTARY SWITCH	SR01240020
			EC16B2410207 L=20 HOL	