

# Service Manual

PMD351 /N1B/U1B

Stereo Cassette Deck / Compact Disc Player

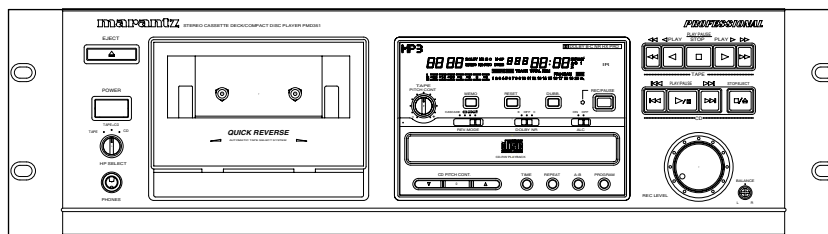

## TABLE OF CONTENTS

SECTION	PAGE
1. TECHNICAL SPECIFICATIONS .....	1
2. SERVICE HINTS AND TOOLS .....	2
3. TEST EQUIPMENT REQUIRED FOR SERVICING.....	3
4. ELECTRICAL ADJUSTMENTS .....	3
5. TECHNICAL DESCRIPTION .....	10
6. SERVICE PROCEDURE.....	12
7. SERVICE MODE.....	13
8. WIRING DIAGRAM .....	15
9. BLOCK DIAGRAM .....	17
10. SCHEMATIC DIAGRAM.....	19
11. PARTS LOCATION.....	33
12. MICROPROCESSOR AND IC DATA.....	38
13. EXPLODED VIEW AND PARTS LIST.....	47
14. ELECTRICAL PARTS LIST.....	53

Please use this service manual with referring to the user guide ( D.F.U. ) without fail.  
修理の際は、必ず取扱説明書を準備し操作方法を確認の上作業を行ってください。

# marantz®

## PMD351

## MARANTZ DESIGN AND SERVICE

Using superior design and selected high grade components, **MARANTZ** company has created the ultimate in stereo sound. Only original **MARANTZ** parts can insure that your **MARANTZ** product will continue to perform to the specifications for which it is famous.

Parts for your **MARANTZ** equipment are generally available to our National Marantz Subsidiary or Agent.

### ORDERING PARTS :

Parts can be ordered either by mail or by Fax.. In both cases, the correct part number has to be specified.

The following information must be supplied to eliminate delays in processing your order :

1. Complete address
2. Complete part numbers and quantities required
3. Description of parts
4. Model number for which part is required
5. Way of shipment
6. Signature : any order form or Fax. must be signed, otherwise such part order will be considered as null and void.

#### USA

**MARANTZ AMERICA, INC**  
1100 MAPLEWOOD DRIVE  
ITASCA, IL. 60143  
USA  
PHONE : 630 - 741 - 0300  
FAX : 630 - 741 - 0301

#### EUROPE / TRADING

**MARANTZ EUROPE B.V.**  
P. O. BOX 8744, BUILDING SILVERPOINT  
BEEMDSTRAAT 11, 5653 MA EINDHOVEN  
THE NETHERLANDS  
PHONE : +31 - 40 - 2507844  
FAX : +31 - 40 - 2507860

#### CANADA

**LENBROOK INDUSTRIES LIMITED**  
633 GRANITE COURT,  
PICKERING, ONTARIO L1W 3K1  
CANADA  
PHONE : 905 - 831 - 6333  
FAX : 905 - 831 - 6936

#### PROFESSIONAL AMERICAS

**SUPERSCOPE TECHNOLOGIES, INC.**  
MARANTZ PROFESSIONAL PRODUCTS  
2640 WHITE OAK CIRCLE, SUITE A  
AURORA, ILLINOIS 60504 USA  
PHONE : 630 - 820 - 4800  
FAX : 630 - 820 - 8103

#### PROFESSIONAL AUSTRALIA

**TECHNICAL AUDIO GROUP PTY, LTD**  
43-53 Bridge Rd.,  
STANMORE NSW 2048  
AUSTRALIA  
PHONE : +61 - (0)2 - 9519 - 0900  
FAX : +61 - (0)2 - 9519 - 0600

#### PROFESSIONAL HONG KONG

**Jolly ProAudio Broadcast Engineering Ltd.**  
UNIT 2, 10F, WAH HUNG CENTRE,  
41 HUNG TO ROAD, KWUN TONG, KLN.,  
HONG KONG  
PHONE : 852 - 21913660  
FAX : 852 - 21913990

#### AUSTRALIA

**QualiFi Pty Ltd,**  
24 LIONEL ROAD,  
MT. WAVERLEY VIC 3149  
AUSTRALIA  
PHONE : +61 - (0)3 - 9543 - 1522  
FAX : +61 - (0)3 - 9543 - 3677

#### THAILAND

**MRZ STANDARD CO., LTD**  
746 - 754 MAHACHAI ROAD.,  
WANGBURAPAPIROM, PHRANAKORN,  
BANGKOK, 10200 THAILAND  
PHONE : +66 - 2 - 222 9181  
FAX : +66 - 2 - 224 6795

#### SINGAPORE

**WO KEE HONG DISTRIBUTION PTE LTD**  
130 JOO SENG ROAD  
#03-02 OLIVINE BUILDING  
SINGAPORE 368357  
PHONE : +65 6858 5535 / +65 6381 8621  
FAX : +65 6858 6078

#### NEW ZEALAND

**WILDASH AUDIO SYSTEMS NZ**  
14 MALVERN ROAD MT ALBERT  
AUCKLAND NEW ZEALAND  
PHONE : +64 - 9 - 8451958  
FAX : +64 - 9 - 8463554

#### TAIWAN

**PAI- YUING CO., LTD.**  
6 TH FL NO, 148 SUNG KIANG ROAD,  
TAIPEI, 10429, TAIWAN R.O.C.  
PHONE : +886 - 2 - 25221304  
FAX : +886 - 2 - 25630415

#### MALAYSIA

**WO KEE HONG ELECTRONICS SDN. BHD.**  
2ND FLOOR BANGUNAN INFINITE CENTRE  
LOT 1, JALAN 13/6, 46200 PETALING JAYA  
SELANGOR DARUL EHSAN, MALAYSIA  
PHONE : +60 - 3 - 7954 8088  
FAX : +60 - 3 - 7954 7088

#### JAPAN Technical

**MARANTZ JAPAN, INC.**  
35- 1, 7- CHOME, SAGAMIONO  
SAGAMIHARA - SHI, KANAGAWA  
JAPAN 228-8505  
PHONE : +81 42 748 1013  
FAX : +81 42 741 9190

#### 日本マランツ株式会社

本社 〒228-8505  
神奈川県相模原市相模大野7-35-1  
営業本部 〒150-0022  
東京都渋谷区恵比寿南1-11-9

#### KOREA

**MK ENTERPRISES LTD.**  
ROOM 604/605, ELECTRO-OFFICETEL, 16-58,  
3GA, HANGANG-RO, YONGSAN-KU, SEOUL  
KOREA  
PHONE : +822 - 3232 - 155  
FAX : +822 - 3232 - 154

### SHOCK, FIRE HAZARD SERVICE TEST :

**CAUTION :** After servicing this appliance and prior to returning to customer, measure the resistance between either primary AC cord connector pins ( with unit NOT connected to AC mains and its Power switch ON ), and the face or Front Panel of product and controls and chassis bottom.

Any resistance measurement less than 1 Megohms should cause unit to be repaired or corrected before AC power is applied, and verified before it is return to the user/customer.

Ref. UL Standard No. 1492.

In case of difficulties, do not hesitate to contact the Technical Department at above mentioned address.

# 1. TECHNICAL SPECIFICATIONS

## TAPE DECK

Track System .....4 Track, 2 Channel  
Recording/Erase System..... AC 105 kHz Bias  
Head System (Rotary type combination)  
    Rec Play Head ..... Hard Metal Alloy  
    Erase Head ..... Dual Gap Ferrite  
Motor System  
    Capstan ..... DC Servo Controlled Motor  
    Reel ..... DC Motor  
Wow & Flutter  
    W RMS..... 0.14%  
Frequency Characteristics  
    Frequency Response (no Dolby NR)  
        type I (Normal) ..... 30Hz-15kHz  $\pm$ 3dB  
        type II (High) ..... 30Hz-16kHz  $\pm$ 3dB  
        type IV (Metal) ..... 30Hz-16kHz  $\pm$ 3dB  
Overall S/N (no Dolby NR, IEC-A WTD)  
    type I (Normal) ..... 53dB  
    type II (High) ..... 54dB  
    type IV (Metal) ..... 55dB  
Dolby NR effect (B/C, S/N improvement, CCIR-ARM WTD)  
    ..... B 9dB, C 18dB  
Output Level/Output Impedance..... 500mV/1k $\Omega$   
Input Sensitivity/Input Impedance  
    TAPE IN ..... 100mV/47k $\Omega$   
    MIC IN..... 0.5mV/10k $\Omega$

## CD

Channels ..... 2  
Sampling frequency..... 44.1 kHz  
Quantization ..... 16-bit linear/channel  
Error correction system ..... Cross-interleave Reed-Solomon code (CIRC)  
D/A Conversion ..... 1-bit linear/channel  
Wow & Flutter ..... Quartz crystal accuracy  
Optical Readout System  
    Laser ..... AlGaAs semiconductor  
    Wavelength ..... 780 nm  
Frequency Characteristics (Pitch control off)  
    Frequency Response ..... 20Hz-20kHz  $\pm$ 0.3dB  
    Dynamic range..... 90 dB  
    Signal-to-noise ratio ..... 96 dB  
    Channel separation..... 90 dB  
    Total harmonic distortion..... 0.005% (1 kHz)  
Analog output  
    Output Level..... 2V RMS stereo  
    Output Impedance..... <1k $\Omega$   
Digital output  
    Coaxial output ..... 0.5Vp-p/75 $\Omega$

## COMMON PART

Power Supply  
    /U ..... 120V AC 60Hz  
    /N ..... 230V AC 50Hz  
Dimensions  
    Width ..... 19 inches (483mm)  
    Height ..... 5 3/16 inches (133mm)  
    Depth ..... 11 1/32 inches (280mm)  
Net Weight ..... 3.1 lbs. (6.8kg)

## 2. SERVICE HINTS AND TOOLS

### SERVICE HINTS

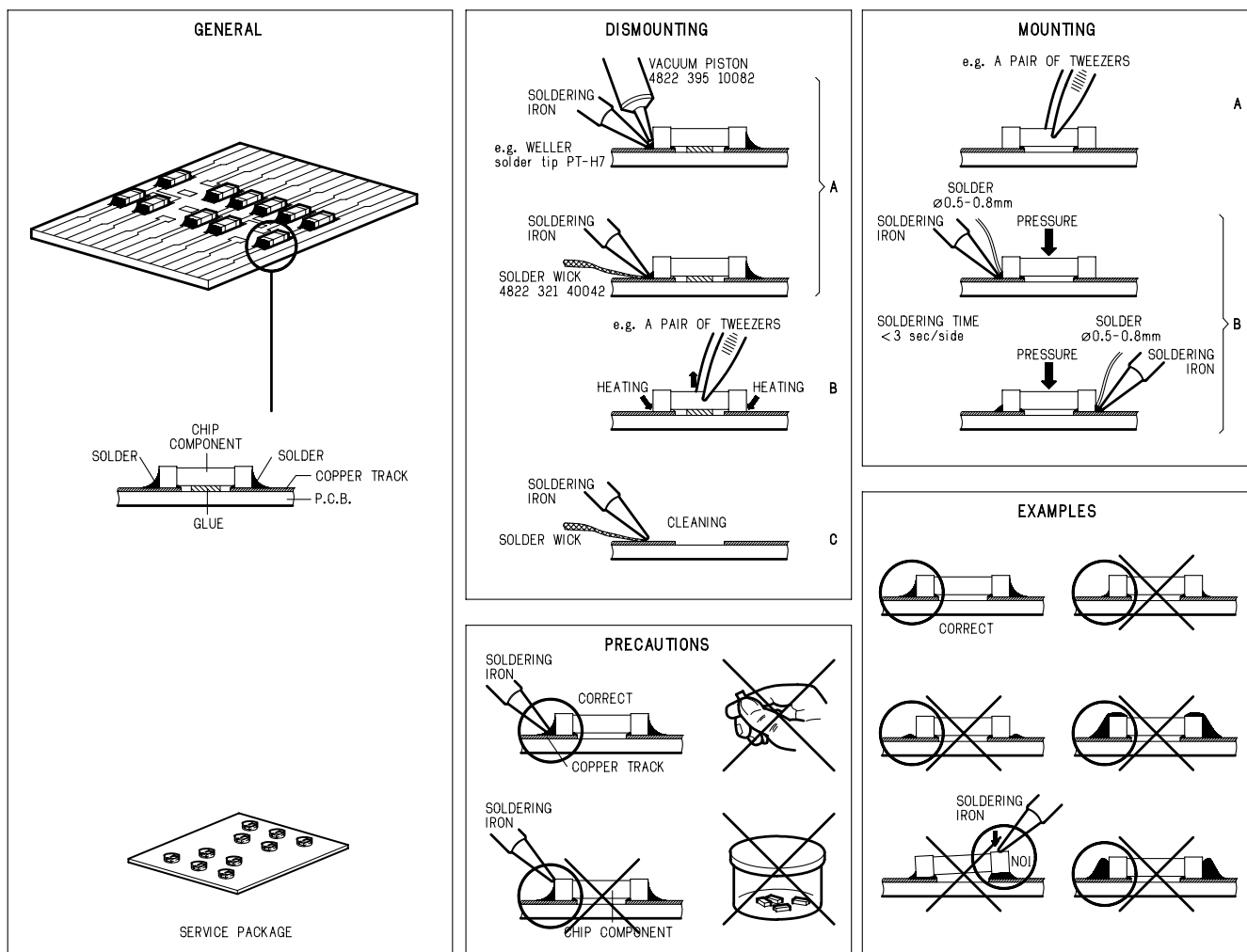

### SERVICE TOOLS

Audio signals disc	4822 397 30184
Disc without errors (SBC444)+	
Disc with DO errors, black spots and fingerprints (SBC444A)	4822 397 30245
Disc (65 min 1kHz) without no pause	4822 397 30155
Max. diameter disc (58.0 mm)	4822 397 60141
Torx screwdrivers	
Set (straight)	4822 395 50145
Set (square)	4822 395 50132
13th order filter	4822 395 30204
DVD test disc (PAL)	4822 397 10131
DVD test disc (NTSC) ALMEDIO	TDV-540

## ◆ サービス時に必要な試験器材

● この Model を測定又はチェックするのに次のものがが必要です。

- オーディオ発振器
- アッテネータ (600 Ω)
- オーディオノイズメーター
- オシロスコープ
- ワウ、フラッターメーター
- トルクメーター (カセット型)
- デジタル周波数カウンター
- ブランクテープ  
(バルクイレーサーで完全に消去したもの)  
AC-225 (Normal) AC-713 (Metal)  
AC-514 (High Position)

注意：

測定値の異常がテープに起因すると考えられる場合は新しいものと交換し再測定して下さい。

- テストテープ  
TCC-112・MTT-111.....ワウ・フラッタ、テープスピード  
TCC-120・MTT-212N..... S/N 比  
TCC-130・MTT-150.....出力レベル調整  
TCC-174A・MTT-255M...アジマス調整  
(TCC-\*\*\*\*:A-BEX/MTT-\*\*\*\*:TEAC)
- ヘッドおよびガイドゲージ (M-300)  
THG-801.....ヘッド、ガイド調整

## ◆ 回路の調整 と測定

### A. 調整上の注意点

- 1) テストテープは減衰しやすいので、使用する前にヘッド、キャプスタン等をイレーサーにて十分に消磁すること。
- 2) テストテープはトランス内蔵の計測機やイレーサーのすぐ近くには置かないこと。
- 3) 消磁の方法として、セットからやや離れた所でイレーサーのスイッチを入れヘッド、キャプスタンに近づけ上下に4～5回動かし、ゆっくり離し遠ざけてからスイッチを切ること。
- 4) 使用する工具は帯磁していないこと、時々バルクイレーサーで消磁すること。
- 5) 調整用半固定抵抗および可変コイル等は、極力最少の回転 / 回数で調整すること。
- 6) スピード、ワウ等は、セットの通常の姿勢で調整 / チェックすること。
- 7) ボンドロックは少量にし、周辺に付着あるいは流れ出ることなど無いよう注意のこと。
- 8) AC 電源電圧、低周波発振器出力電圧等は、1日2～3回規定どうりかチェックすること。

## 3. TEST EQUIPMENT REQUIRED FOR SERVICING

For measuring or checking a Cassette Deck, the following instruments and materials are necessary.

- Audio Oscillator (Audio Signal Generator)
- Attenuator (600 ohm)
- Audio Noise Meter
- Oscilloscope
- Wow and Flutter Meter
- Torque Meter (Cassette Type)
- Digital Frequency Counter
- Test Tape  
TCC-112/MTT-111      Wow/Flutter, Tape Speed  
TCC-120/MTT-212N    Signal-to-Noise Ratio  
TCC-130/MTT-150    Dolby Level Adjustment  
TCC-174A/MTT-255M   Azimuth Adjustment  
(TCC-\*\*\*\*:A-BEX/MTT-\*\*\*\*:TEAC)
- Blank Tapes (Completely erased with bulk eraser)  
AC-225 (Normal)  
AC-514 (High Position)  
AC-713 (Metal)

NOTE:

If any doubt is noted in a measured value, which is due to a tape. Re-measurement is necessary by use the new tape.

- Mirror cassette 12um padless  
TCC-902/MTT-902    Tape flowing check
- Head guide gauge (M-300)  
THG-801

## 4. ELECTRICAL ADJUSTMENTS

### (A) Remark for adjustment

- 1) Clean and de-magnetize the tape path part before measurement.
- 2) Keep cassette tapes away from equipments.
- 3) De-magnetize tools often.
- 4) Do not turn adjustment parts by strong force.
- 5) Keep a cassette deck horizontally while measuring.
- 6) Keep amount of glue in proper.
- 7) Confirm the mains voltage, output level of oscillator and etc. before adjustment and measurement.

B. S.R.L. (Standard Recording Level) 基準録音レベル

1. テープ上に開回路磁束で、250nWb/m の磁束を記録出来るレベルのことであり、記録レベルとテストテープの関係は以下のとおりである。

TCC-120 (MTT-212)	(IEC REFERENCE LEVEL) S.R.L.	160	185	200	220	250
• 開回路磁束 (nWb/m) .....						
• 閉回路磁束 (nWb/m) .....						
TCC-130 (MTT-150)	(DOLBY REFERENCE LEVEL)	160	185	200		

注意：開回路磁束 = 閉回路磁束 + 漏洩磁束

2. PMD351 ではドルビーレベルで再生出力を調整し、基準を IEC リファレンスにしているが、便宜上以下のようにする。
- 1) LINE 入力に 1kHz, 100mV の信号を加え録音状態とする。
  - 2) REC ボリュームを調整し、ドルビーテストポイント T601 (L), T601 (R) のレベルが 300mV となるようにする。
  - 3) この状態から入力レベルを +1dB とした状態がすなわち、基準録音レベル (S.R.L.) での規定録音状態である。

注意：

再生の基準レベルはその測定項目により異なり、使用指定のテストテープの記録レベルが基準レベルを決定することになる。

**(B) S.R.L. (Standard Recording Level)**

1. The Standard Recording Level is a signal of 250nWb/m on a tape at \*OPEN CIRCUIT MAGNETIC FLUX.  
The relation between the recording level and a test tape is as follows.

• OPEN CIRCUIT MAGNETIC FLUX (nWb/m)	160	185	200	220	250
• CLOSED CIRCUIT MAGNETIC FLEX (nWb/m)		160	185	200	

(\*): OPEN CIRCUIT MAGNETIC FLUX = CLOSED CIRCUIT MAGNETIC FLUX + LEAK MAGNETIC FLUX.

(\*\*): TCC-130 (DOLBY REFERENCE LEVEL) (MTT-150)

(\*\*\*): TCC-120 (IEC REFERENCE LEVEL) (S.R.L.) (MTT-212N)

2. S.R.L. Setting

- 1) Apply a 1kHz, 100mV to the LINE INPUT jacks.
- 2) Put the unit in RECORD mode and adjust the REC LEVEL control to obtain the following level of signal at the DOLBY test points T601 (L), T602 (R) 300mV.
- 3) Adjust the output of the audio oscillator applied to the LINE INPUT jacks to 112.2mV (+1dB). This is the rated recording condition for the STANDARD RECORDING LEVEL.

調整フローチャート

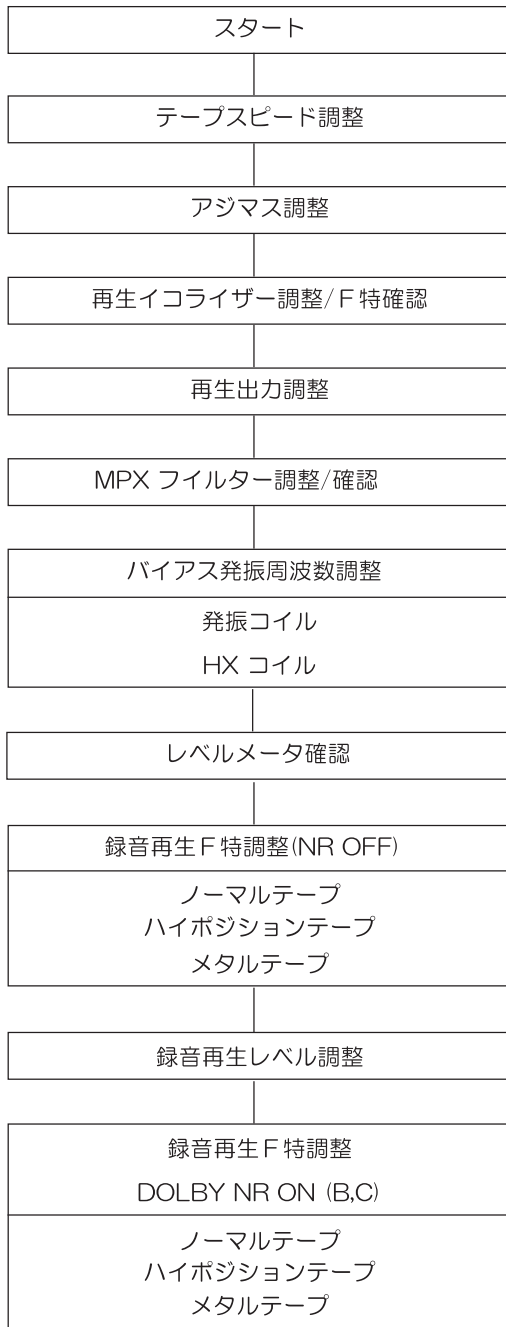

ADJUSTMENT FLOW CHART

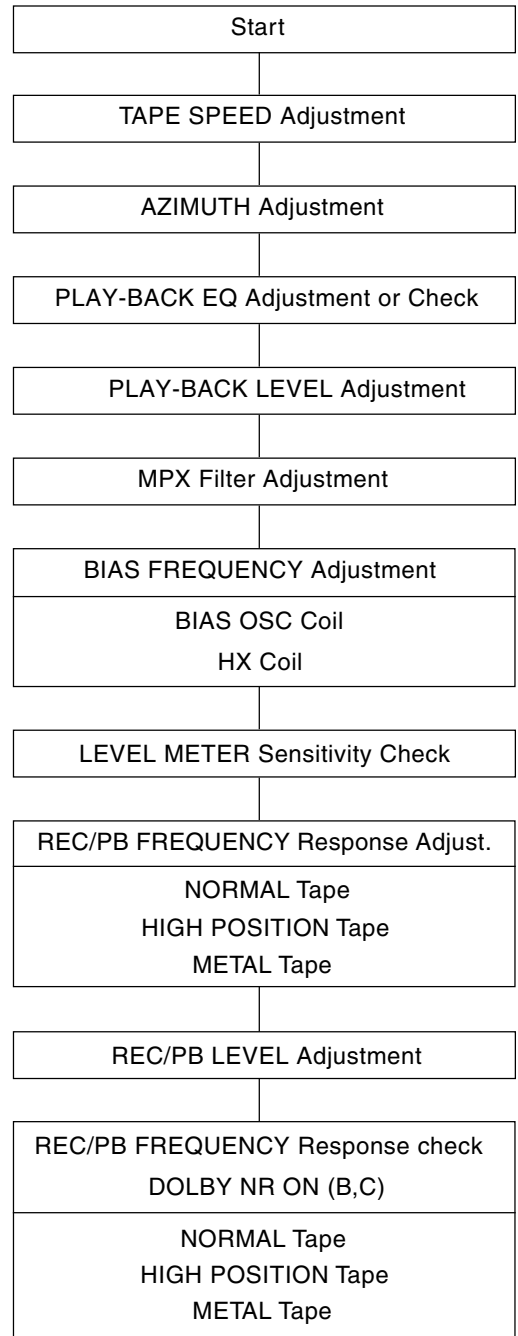





● テープスピード調整

調整は、FWD (PLAY<) で行い、REV (> PLAY) 再生は、スベック内であることを確認する。

- 1) テープの中間を再生し、半固定抵抗 (RM36) を調整し、3000Hz (2990 ~ 3010Hz) になるようにする。
- 2) 設定後、再度再生して範囲内のことを確認する。

注意：

- (1) 据置き姿勢で行なう。
- (2) メカニズムが常温と大きく異なる温度状態では、行なわないこと。

● ヘッドアジマス調整 / 再生F特調整

- 1) アジマス調整用テープの、12.5kHz の信号を再生する。アジマス調整ビスを回し、締め付け方向で出力最大点に合わせる。
- 2) L/R ピーク点が違う場合は、低いチャンネル側を最大にし、L/R のバランスを取る。
- 3) 調整ビスをボンドロックする。
- 4) 次に、315Hz の信号を 0dB とし、12.5kHz の信号のレベルを読む。無調整タイプのセットなので異常な値でないことを確認する。

● 再生出力調整

- 1) ドルビーレベルテストテープを再生し、テストポイントの電圧が 300mV となるように調整する。

CH	測定点	調整点	調整値
L R	T601 T602	RJ15 RJ16	300mV

- 2) 調整後再度再生し、再確認する。

4.1 TAPE SPEED ADJUSTMENT

- 1) Playback the middle part of the Wow & Flutter test tape.
- 2) Adjust the variable resistor.

ADJUSTMENT POINT
RM36

for 3000Hz (2990Hz - 3010Hz).

- 3) Repeat 1) and 2) for both directions.

4.2 HEAD AZIMUTH ADJUSTMENT and FREQUENCY RESPONSE CHECK

- 1) Playback the 12.5 kHz part of the Azimuth test tape.
- 2) Adjust the proper azimuth screw in both directions for maximum output at the LINE OUTPUT jacks.
- 3) In case the L/R peak points are different, adjust the lower channel to the maximum.
- 4) Lock azimuth screws with glue.
- 5) Playback the 315 Hz part of the test tape and set a 0 dB ref., then playback the 12.5 kHz part of the test tape and confirm that the output is 0 dB, ±3 dB.

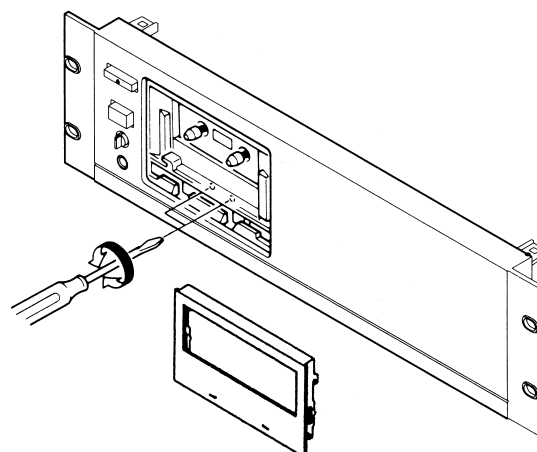

4.3 PLAYBACK LEVEL ADJUSTMENT

- 1) Playback the DOLBY test tape, adjust the following variable resistors to the values and the test points indicated below:

CH	TEST POINT	ADJ. RES.	ADJUSTMENT VALUE
L	T601	RJ15	300mV
R	T602	RJ16	

- 2) After adjustment, replay and check it again.

Remark:

In case of drifting output during replay, check that the tape running and the test tape are ok, because they may be defective.

● MPX フィルター周波数調整／確認

- 1) ドルビーレベルで録音モニター状態とし、入力信号周波数が 1kHz の時のレベルを 0dB とする。
- 2) 入力信号周波数を 19kHz (± 10Hz 以内) とし、MPX フィルタースイッチが「ON」の状態レベルが最小となるようにコイル調整する。

CH	調整点	調整値
L R	L601 L602	Minimum

● 録音バイアス周波数及び HX コイル共振調整

- 1) 録音状態にする。
- 2) バイアス共振周波数を 105kHz となるよう共振コイルを調整する。

測定点	調整点	調整値
R901	LL01	105kHz

\* 周波数カウンタへの接続は、ミリバルを通して行なう。  
調整 / 測定が終わったら接続を外すこと。

- 3) 次に、HX チェックポイントにオシロスコープを接続する。
- 4) HX チェックポイントの電圧が最小になる様に HX コイルを調整する。

CH	測定点	調整点	調整値
L R	T901 T902	L901 L902	Minimum

● レベルメータ感度確認

- 1) LINE 入力 1kHz 100mV (アッテネータ、-20dB) にて録音状態とする。次に、REC-LEVEL ボリュームを調整し、ドルビーテストポイント T601, T602 のレベルが 300mV となるようにする (●再生出力調整参照)。この状態から 1dB レベルを上げる。
- 2) この状態で、レベルメータの 0dB ポイントが点燈していることを確認する。

注意：

- (1) NR OFF とする。

4.4 MPX FILTER ADJUSTMENT

- 1) Put the unit in REC mode with a S.R.L. input.
- 2) The MPX filter switch ON and change the input frequency to 19kHz(±10Hz).
- 3) Adjust L601(L), L602(R) for minimum output at the LINE OUTPUT jacks.

CH	ADJ. POINT	ADJ. TO
L R	L601 L602	Minimum

4.5 RECORDING BIAS FREQUENCY AND HX COIL ADJUSTMENT

- 1) Put the unit in REC mode.
- 2) Adjust the following bias oscillator coil for 105kHz at the bias frequency.

TEST POINT	ADJ. POINT	ADJ. TO
R901	LL01	105kHz

Remark:

May have to connect FREQUENCY COUNTER through an AUDIO VOLT METER.

- 3) Next, connect the Oscilloscope to the HX test point (T901, T902).
- 4) Adjust the HX coils for minimum level.

CH	TEST POINT	COIL	ADJ. TO
L R	T901 T902	L901 L902	Minimum

4.6 LEVEL METER SENSITIVITY CHECK

- 1) Put the unit in REC mode with a 1kHz, 100mV signal to the LINE INPUT jacks.
- 2) Set the REC LEVEL at the test point T601, T602 as 300mV.
- 3) Check the VU LEVEL METER indicates 0dB.

Remark:

Dolby switch has to be OFF.

● 録音再生 F 特調整

- 1) 規定録音状態から入力レベルを 5mV(-26dB) に減じ、400Hz と 12.5kHz の信号を Dolby-OFF ポジションで録音する。(NORMAL テープ)
- 2) 巻き戻し再生し、400Hz と 12.5kHz の信号のレベル差を確認し、± 1.0dB 以上の場合は、半固定抵抗を調整し再度、録直し確認する。

CH	調整点
L	R907
R	R908

- 3) High Position、METAL では確認のみを行なう。

● 録音再生レベル調整

- 1) NORMAL テープにて規定録音状態とし、400Hz におけるモニターレベルを 0dB とする。
- 2) 巻き戻し再生し、400Hz のレベルが± 0.5dB 以内となるよう、半固定抵抗を調整する。

CH	調整点
L	RK05
R	RK06

- 3) High Position、METAL では確認のみを行なう。

● DOLBY NR 録音再生 F 特確認

- 1) 規定録音状態から入力レベルを 5mV(-26dB) に減じ、下記の信号を Dolby-B、ポジションで録音する。(NORMAL テープ)  
250Hz、1kHz、3kHz、6.3kHz、10kHz、12.5kHz
- 2) 巻き戻し再生し、各周波数のレベル差が± 1.0dB の範囲となることを確認する。
- 3) Dolby-C ポジションでも同様に確認する。
- 4) High Position、METAL テープでも同様に行ない確認する。

#### 4.7 REC/PLAYBACK FREQUENCY RESPONSE ADJUSTMENT

- 1) Adjust the output level of the audio oscillator to 5.0mV (-26dB) from the S.R.L. recording condition. Record 400Hz and 12.5kHz signals with DOLBY OFF.
- 2) Playback the recorded part and confirm the level of differences between 400Hz and 12.5kHz are within ± 1.0dB. If the level difference is out of allowance, adjust the variable resistor and confirm the playback level of rerecording

CH.	ADJUSTMENT
L	R907
R	R908

- 3) Repeat steps #1 and 2 with High Position and METAL type tapes for confirmation.

#### 4.8 REC/PLAYBACK LEVEL ADJUSTMENT

- 1) Input the 400Hz signal and put the unit into record mode. Measure the output level to set the reference level of 0dB.
- 2) Playback the just recorded part and adjust proper variable resistor, until the REC/PB levels are within ±0.5dB.

CH.	ADJUSTMENT
L	RK05
R	RK06

- 3) Repeat steps #1 and 2 with High Position and METAL type tapes for confirmation.

#### 4.9 REC/PLAYBACK FREQUENCY RESPONSE CHECK DOLBY NR

- 1) Adjust the output level of the audio oscillator to 5.0mV (-26dB) from the S.R.L. recording condition. Record the following signals with DOLBY-B ON and Normal tape at 250Hz, 1kHz, 3kHz, 6.3kHz, 10kHz and 12.5kHz.
- 2) Playback the just recorded part and confirm the difference of levels are within ±1.0dB.
- 3) Repeat steps #1 and 2, with High Position and METAL type tapes.
- 4) Repeat steps #1 and 2, with Dolby-C ON.

## 5. TECHNICAL DESCRIPTION

### How to use the RS-232C connector

This input/output connector (D-Sub 9-pin female) is used for RS-232C external control.

A straight cable available on the market can be connected to this connector to exercise external control and send status information.

- Connector pin assignment

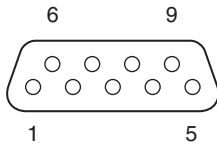

1	NC
2	TX
3	RX
4	NC
5	GND
6	NC
7	RTS
8	CTS
9	NC

- RS232C Connection

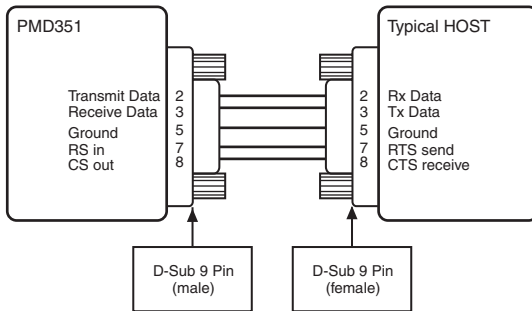

The wiring requirements for a 9 pin to 9 pin serial connection, are a male to female straight cable.

- RS-232C physical specifications

Cable	Straight cable
Baud rate	9600 bps
Data bits	8 bits
Parity bit	None
Stop bit	1 bit
Flow control	CS/RS Hardware Flow

- Command reception

The command packets have a data length of 7 - 10 bytes. ASCII codes from 0x00 to 0x7f are used to receive serial data. At the transmission end, therefore, take steps to convert the ASCII codes into HEX data to set the data in the data packets. CR (0x0d) is added as the data packet delimiter.

Example: Reception Time Command (code @12011)

[@]	[1]	[2]	[0]	[1]	[1]	[CR]
0x40	0x31	0x32	0x30	0x31	0x31	0x0d

When transmitting commands consecutively, put more than 100ms blank between commands.

#### Received command data

Command	CD Command	TAPE Command
0	"@12000"+CR	"@11800"+CR
1	"@12001"+CR	"@11801"+CR
2	"@12002"+CR	"@11802"+CR
3	"@12003"+CR	"@11803"+CR
4	"@12004"+CR	"@11804"+CR
5	"@12005"+CR	"@11805"+CR
6	"@12006"+CR	"@11806"+CR
7	"@12007"+CR	"@11807"+CR
8	"@12008"+CR	"@11808"+CR
9	"@12009"+CR	"@11809"+CR
Time	"@12011"+CR	
Recall	"@12015"+CR	
Repeat	"@12029"+CR	
Next	"@12032"+CR	"@11832"+CR
Previous	"@12033"+CR	"@11833"+CR
Pitch Reset	"@12037"+CR	
Pitch Up Start	"@12038"+CR	
Pitch Up Stop	"@1203801"+CR	
Pitch Down Start	"@12039"+CR	
Pitch Down Stop	"@1203901"+CR	
Program/Memo	"@12041"+CR	"@11841"+CR
AMS	"@12043"+CR	"@11843"+CR
Open/Close	"@12045"+CR	
Pause	"@12048"+CR	"@11848"+CR
Clear	"@12049"+CR	
Fast Backward Start	"@12050"+CR	"@11850"+CR
Fast Backward Stop	"@1205001"+CR	
Fast Forward Start	"@12052"+CR	"@11852"+CR
Fast Forward Stop	"@1205201"+CR	
Play	"@12053"+CR	"@11853"+CR
Stop	"@12054"+CR	"@11854"+CR
A-B	"@12059"+CR	
Direction		"@11847"+CR
REC Mute		"@11842"+CR
REC		"@11855"+CR

- Status confirmation command

When to confirmation of the RS232C operations, the following Status transmitting requirement commands is transmitted to PMD351, status condition is replies.

Request Command for CD		Response from CD	
Power	"@1?20POWE"+CR	Standby	"@120POFF"+CR
		PowerOn	"@120PRON"+CR
TrayMode	"@1?20TRAY"+CR	Open	"@120OPEN"+CR
		Close	"@120CLOS"+CR
PlayMode	"@1?20PLAY"+CR	Toc Reading	"@120TOCR"+CR
		Stop	"@120STOP"+CR
		Play	"@120PLAY"+CR
		Pause	"@120PASE"+CR
		FF	"@120FASF"+CR
		REW	"@120FASR"+CR
Disc	"@1?20DISC"+CR	NoDisc	"@120NODI"+CR
		ERROR	"@120ERDI"+CR
		CDDA	"@120CDDI"+CR
		MP3	"@120MPDI"+CR
RepeatMode	"@1?20RPTM"+CR	OFF	"@120RTOF"+CR
		ONE	"@120RTON"+CR
		ALL	"@120RTAL"+CR
		A-	"@120RTA-"+CR
		A-B	"@120RTAB"+CR
TimeMode	"@1?20TMOD"+CR	Track	"@120TTRA"+CR
		TrackRem	"@120TTRE"+CR
		TotalRem	"@120TREM"+CR
		TotalLap	"@120TTLA"+CR
Album	"@1?20ALBU"+CR		"@120Axxx"+CR
Track	"@1?20TRAC"+CR		"@120Txxx"+CR
Current Display Time	"@1?20TIME"+CR		"@120xxxx"+CR

Request Command for TAPE		Response from TAPE	
Power	"@1?18POWE"+CR	Standby	"@118POFF"+CR
		PowerOn	"@118PRON"+CR
Cassette	"@1?18CASS"+CR	IN	"@118CAIN"+CR
		Eject	"@118CAEJ"+CR
PlayMode	"@1?18PLAY"+CR	Stop	"@118STOP"+CR
		PlayFW	"@118PLFW"+CR
		PlayRV	"@118PLRV"+CR
		Pause	"@118PASE"+CR
		FF	"@118FASF"+CR
		REW	"@118FASR"+CR
		Cue	"@118CUE_"+CR
		Review	"@118REVI"+CR
		Rec	"@118RECO"+CR
		Rec Pause	"@118RECP"+CR
Current Display Time	"@1?18TIME"+CR		"@118xxxx"+CR
Memo	"@1?18MEMO"+CR	OFF	"@118MEOF"+CR
		ON	"@118MEON"+CR

- Status transmission

The status packets have a fixed data length of 8 bytes. ASCII codes from 0x00 to 0x7f are used to transmit serial data. For this reason, the ASCII codes are converted into HEX data before the data is set in the data packets and transmitted. CR (0x0d) is added as the data packet delimiter.

Example 1: Transmission Power On (code @120PRON)

[@]	[1]	[2]	[0]	[P]	[R]	[O]	[N]	[CR]
0x40	0x31	0x32	0x30	0x50	0x57	0x4f	0x4e	0x0d

Transmitted status data

Category	Status from CD	
Power	Standby	"@120POFF"+CR
	PowerOn	"@120PRON"+CR
TrayMode	Open	"@120OPEN"+CR
	Close	"@120CLOS"+CR
PlayMode	Toc Reading	"@120TOCR"+CR
	Stop	"@120STOP"+CR
	Play	"@120PLAY"+CR
	Pause	"@120PASE"+CR
	FF	"@120FASF"+CR
	REW	"@120FASR"+CR
Disc	NoDisc	"@120NODI"+CR
	ERROR	"@120ERDI"+CR
	CDDA	"@120CDDI"+CR
	MP3	"@120MPDI"+CR
RepeatMode	OFF	"@120RTOF"+CR
	ONE	"@120RTON"+CR
	ALL	"@120RTAL"+CR
	A-	"@120RTA-"+CR
TimeMode	Track	"@120TTRA"+CR
	TrackRem	"@120TTRE"+CR
	TotalRem	"@120TREM"+CR
TotalLap	TotalLap	"@120TTLA"+CR

Category	Status from TAPE	
Power	Standby	"@118POFF"+CR
	PowerOn	"@118PRON"+CR
Cassette	IN	"@118CAIN"+CR
	Eject	"@118CAEJ"+CR
PlayMode	Stop	"@118STOP"+CR
	PlayFW	"@118PLFW"+CR
	PlayRV	"@118PLRV"+CR
	Pause	"@118PASE"+CR
	FF	"@118FASF"+CR
	REW	"@118FASR"+CR
	Cue	"@118CUE_"+CR
	Review	"@118REVI"+CR
	Rec	"@118RECO"+CR
	Rec Pause	"@118RECP"+CR
Memo	OFF	"@118MEOF"+CR
	ON	"@118MEON"+CR

## 6. SERVICE PROCEDURE

### Emergency Eject

1. To open the stucked tray, insert a minus driver into the hole of bottom and push the eject lever.
2. Use a minus driver. (width is about 4 mm)

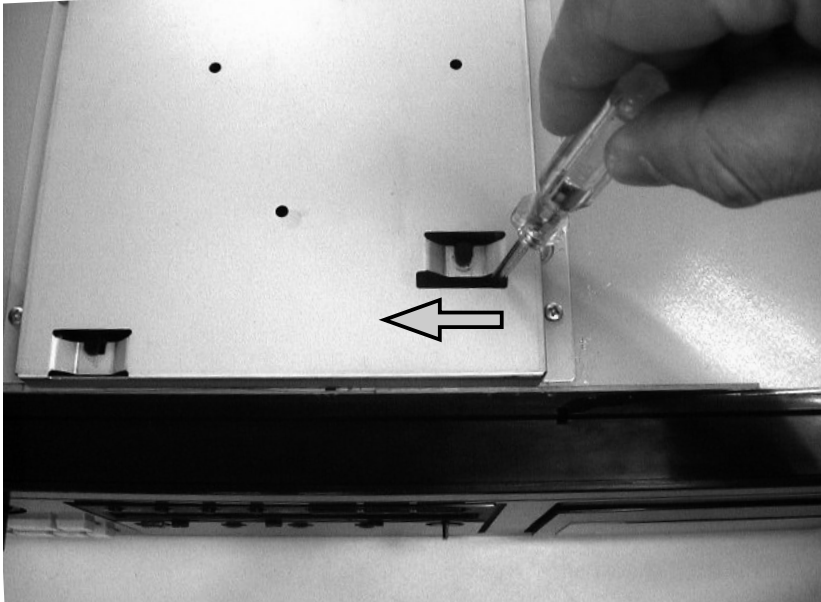

This picture shows the unit upside down. The eject lever is pointed by the arrow. The lever is thin so aim the narrow area carefully.

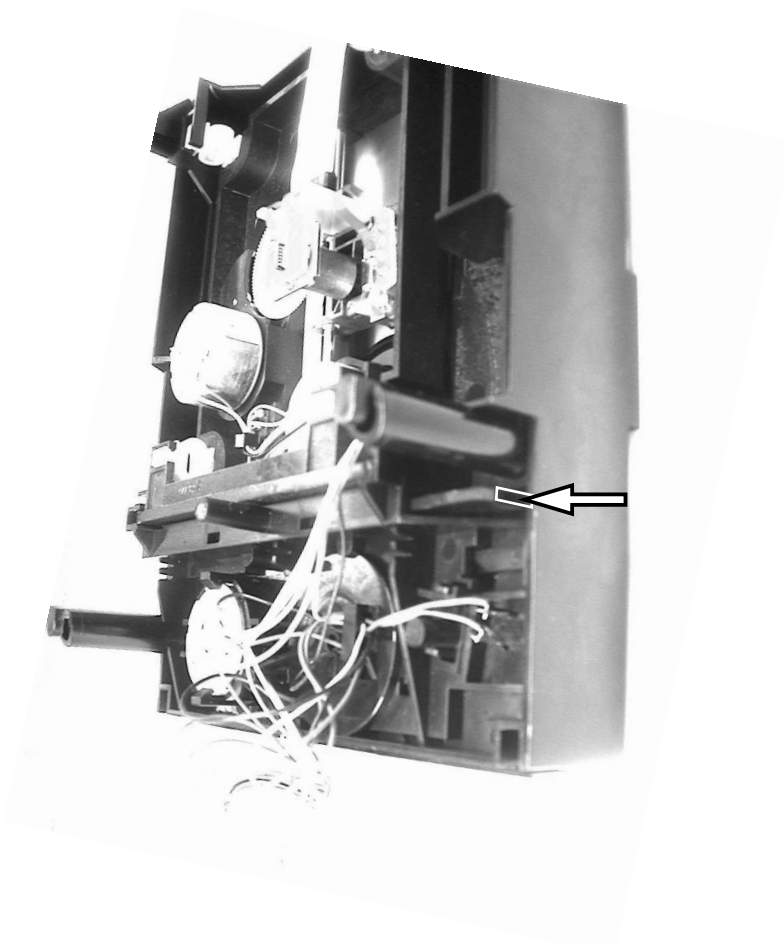

## 7. SERVICE MODE

### 1. How to enter into the Service Mode

While pressing **PROGRAM**, **STOP/EJECT**(CD) and **STOP**(TAPE) buttons, press **POWER** button.

" \*\*\* 00 " is displayed

" \*\*\* " is Version number of the microprocessor.

### 2. Mode0 (Display : \*\*\* 00 )

Status: [FOCUS OFF] [SPINDLE OFF] [RADIAL OFF] [MUTE ON]

- While pressing **◀◀** and **▶▶** buttons, the sledge moves toward the outer edge. Release the button makes the sledge return to the origin.

Press **NEXT ▶▶** button to go to Mode 1.

### 3. Mode 1 (Display : \*\*\* 01)

Status: [FOCUS ON] [SPINDLE OFF] [RADIAL OFF] [MUTE ON]

- Press **NEXT ▶▶** button to go to Mode 2.
- Press **PREV ◀◀** button to go to Mode 0.

### 4. Mode 2 (Display : \*\*\* 02)

Status: [FOCUS ON] [SPINDLE ON] [RADIAL OFF] [MUTE ON]

- Press **NEXT ▶▶** button to go to Mode 3.
- Press **PREV ◀◀** button to go to Mode 1.

### 5. Mode 3 (Display : \*\*\* 03)

Status: [FOCUS ON] [SPINDLE ON] [RADIAL ON] [MUTE OFF]

- Press **PREV ◀◀** button to go to Mode 2.

### 6. Others

\* In the Mode 0 or 1, pressing the number button 3 on the remote makes the spindle motor rotate and "FrEE" is displayed. Press the number button 4 to stop rotation.

\* In this Service Mode, all of the following button functions work in any status.

- 1) Press **TIME** button, " **FL disp** " is displayed. Press it again then each FL segment lights up one by one. Press it again then light up all the FL segments. Press **STOP/EJECT** button to go to Mode 0
- 2) Press **STOP/EJECT** button, " **Code** " is displayed. Then press a button on the unit. The name of the button is displayed. Pressing a button on the Remote controller for RC-5 unit display the RC-5 code (Ex. : **rc2001**) of the button. Press **STOP/EJECT**(CD) and **STOP**(CD) button to go to Mode 0.

	6	5	4	3	2	1	0
1	PITCH +	TIME	One-way mode	MEMO	STOP/EJECT	◀◀ (REW)	◀ (PLAY)
2	PITCH 0	REPEAT	Continuous mode	RESET	▶▶ (NEXT)	STOP	▶ (PLAY)
3	PITCH -	PROGRAM	CASCADE	ALC ON	◀◀ (PREV)	PLAY/PAUSE	▶▶ (FF)
4		A-B	DOLBY-C	DOLBY-B		DUBB.	REC/PAUSE

Ex.: Press **PITCH +** button, "1-6" is displayed.

### 7. Terminating Service Mode

Turn off power to quit Service Mode.

## 7. サービスモード

### 1. サービスモードへの入り方

**PROGRAM** と **STOP/EJECT**(CD) と **STOP**(TAPE) ボタンを押しながら **POWER** ボタンを押します。

" \*\*\* 00 " と表示されます。(モード 0)

" \*\*\* " はマイコンの **Ver.** です。

### 2. モード 0 (表示 : \*\*\* 00 )

状態 : [FOCUS OFF] [SPINDLE OFF] [RADIAL OFF] [MUTE ON]

- **◀◀** または **▶▶** ボタンを押している間だけスレッドが外周へ移動します。ボタンを放すと原点に戻ります。
- **NEXT ▶▶** ボタンを押すとモード 1 へ移行します。

### 3. モード 1 (表示 : \*\*\* 01)

状態 : [FOCUS ON] [SPINDLE OFF] [RADIAL OFF] [MUTE ON]

- **NEXT ▶▶** ボタンを押すとモード 2 へ移行します。
- **PREV ◀◀** ボタンを押すとモード 0 へ移行します。

### 4. モード 2 (表示 : \*\*\* 02)

状態 : [FOCUS ON] [SPINDLE ON] [RADIAL OFF] [MUTE ON]

- **NEXT ▶▶** ボタンを押すとモード 3 へ移行します。
- **PREV ◀◀** ボタンを押すとモード 1 へ移行します。

### 5. モード 3 (表示 : \*\*\* 03)

状態 : [FOCUS ON] [SPINDLE ON] [RADIAL ON] [MUTE OFF]

- **PREV ◀◀** ボタンを押すとモード 2 へ移行します。

### 6. その他

\* モード 0 または 1 の状態からリモートコントロールの数字 **3** を押すと " **FrEE** " と表示されスピンドルモーターが回転し、数字 **4** 押すと回転が止まります。

\* サービスモードの全ての状態で以下のボタンが有効です。

- 1) **TIME** ボタンを押すと " **FL disp** " と表示されもう一度押すと各セグメントが順次点灯します。もう一度押すと FL が全点灯します。**STOP/EJECT** ボタンを押すと、このモードは解除されます。
- 2) **STOP/EJECT** ボタンを押すと " **Code** " と表示され、本体のボタンを押すとそのボタンの名前が下記表の KEY MATRIX に対応した数字が表示されます。RC-5 対応リモコンのボタンを押すと RC-5 コードが表示 (例 : **rc2001**) されます。**STOP/EJECT**(CD) と **STOP**(CD) ボタンを押すと、このモードは解除されます

### 7. サービスモードの解除

電源を切るとサービスモードが解除されます。





8. WIRING DIAGRAM

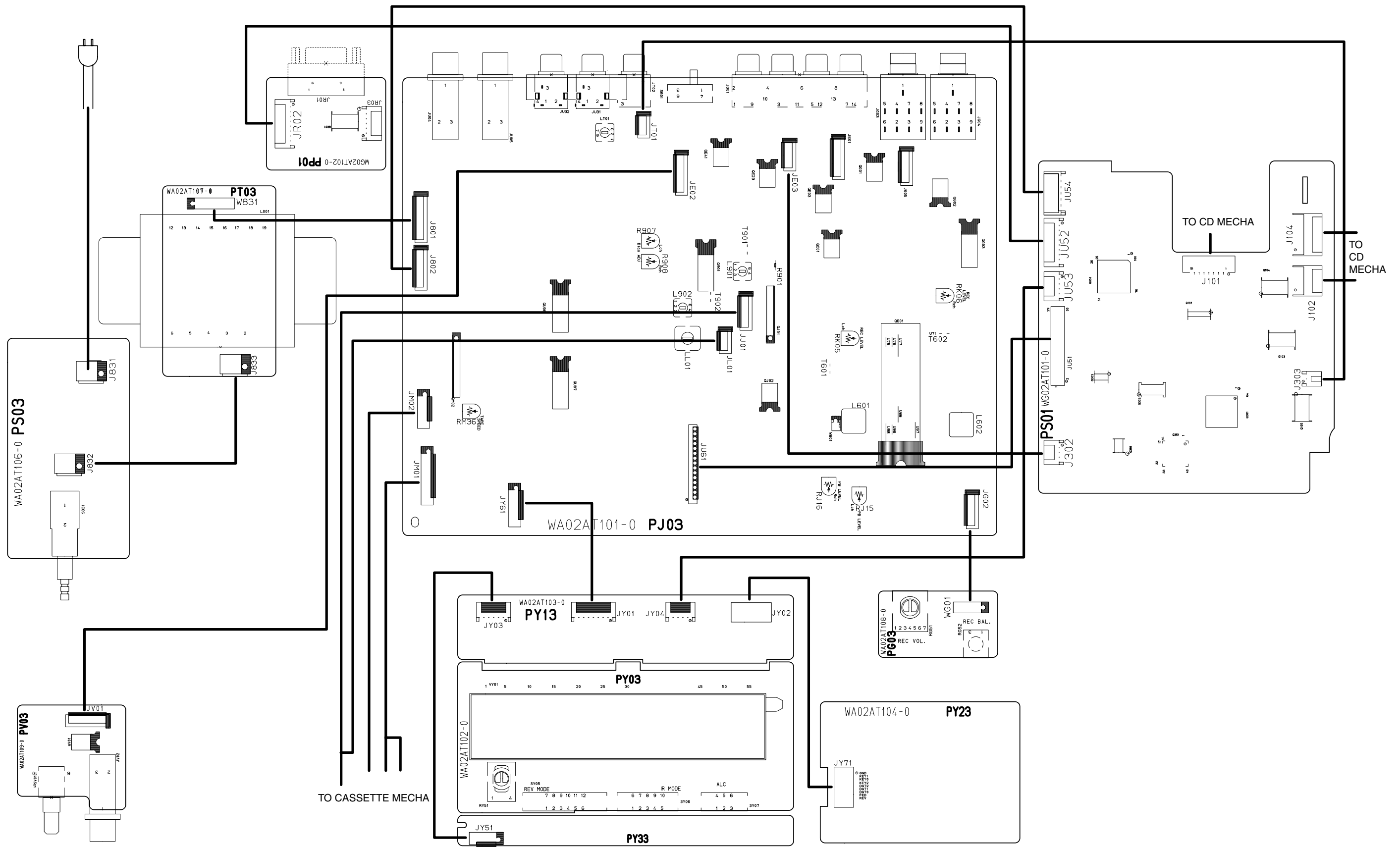

9. BLOCK DIAGRAM

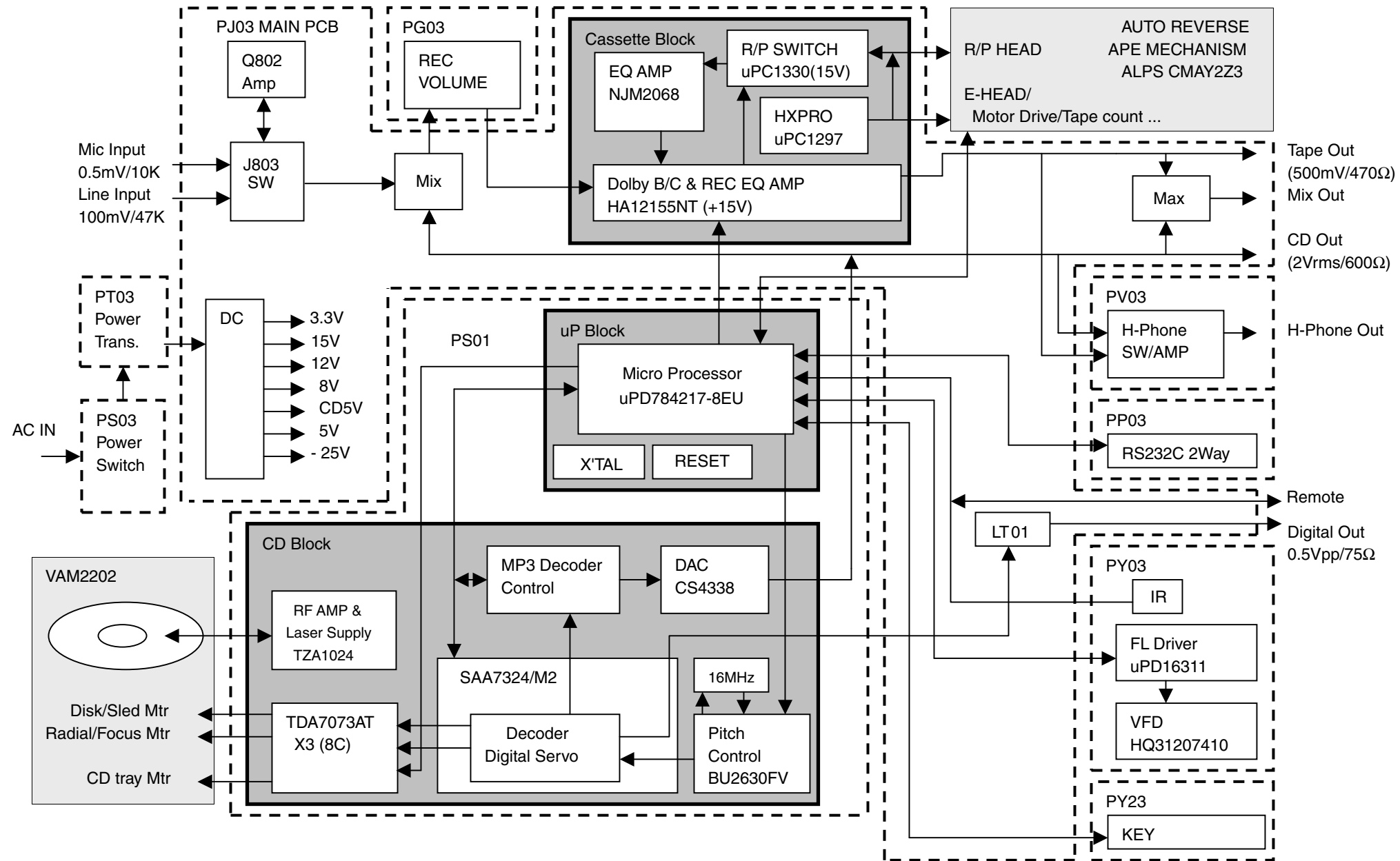

# 10. SCHEMATIC DIAGRAM

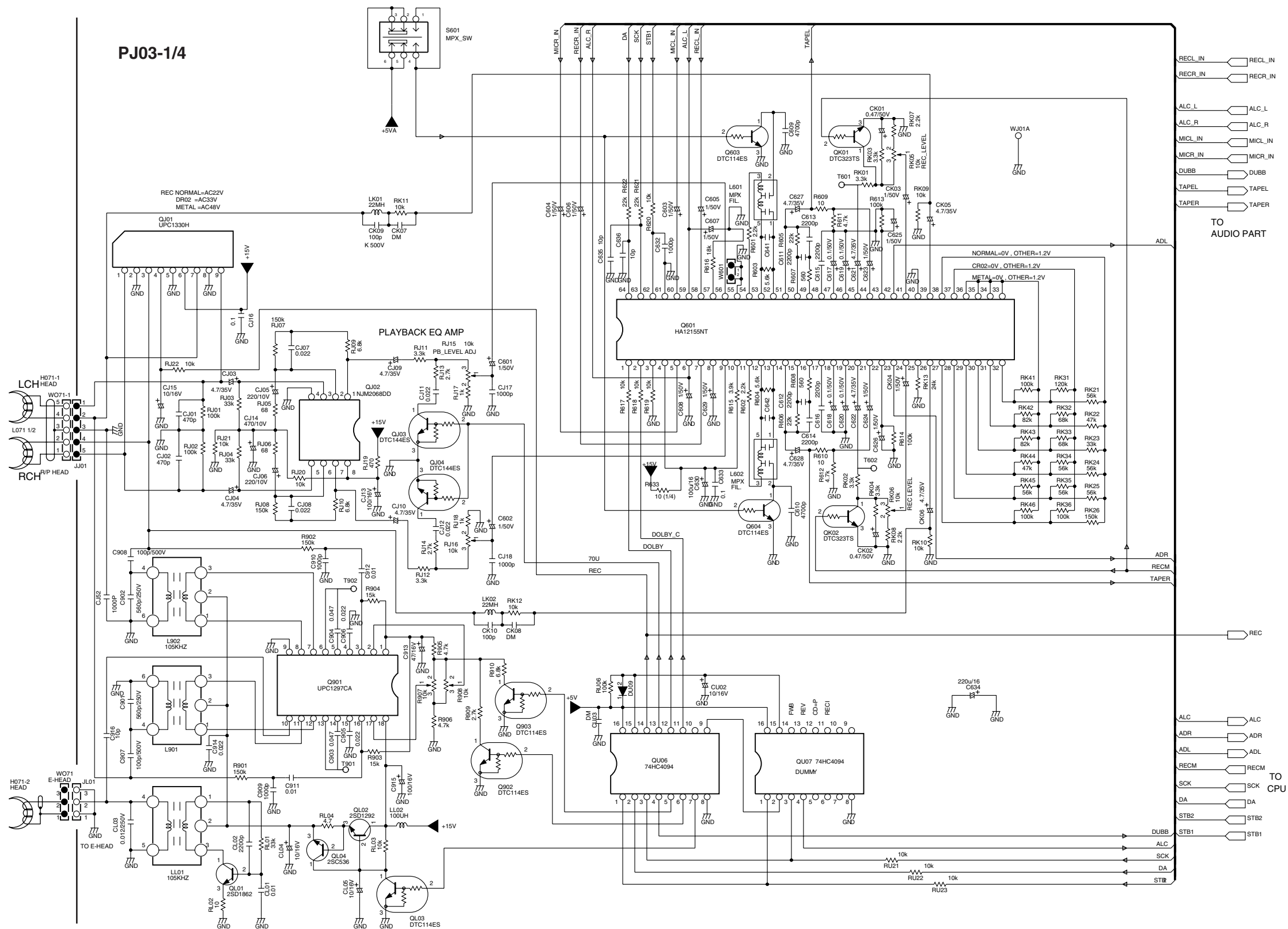

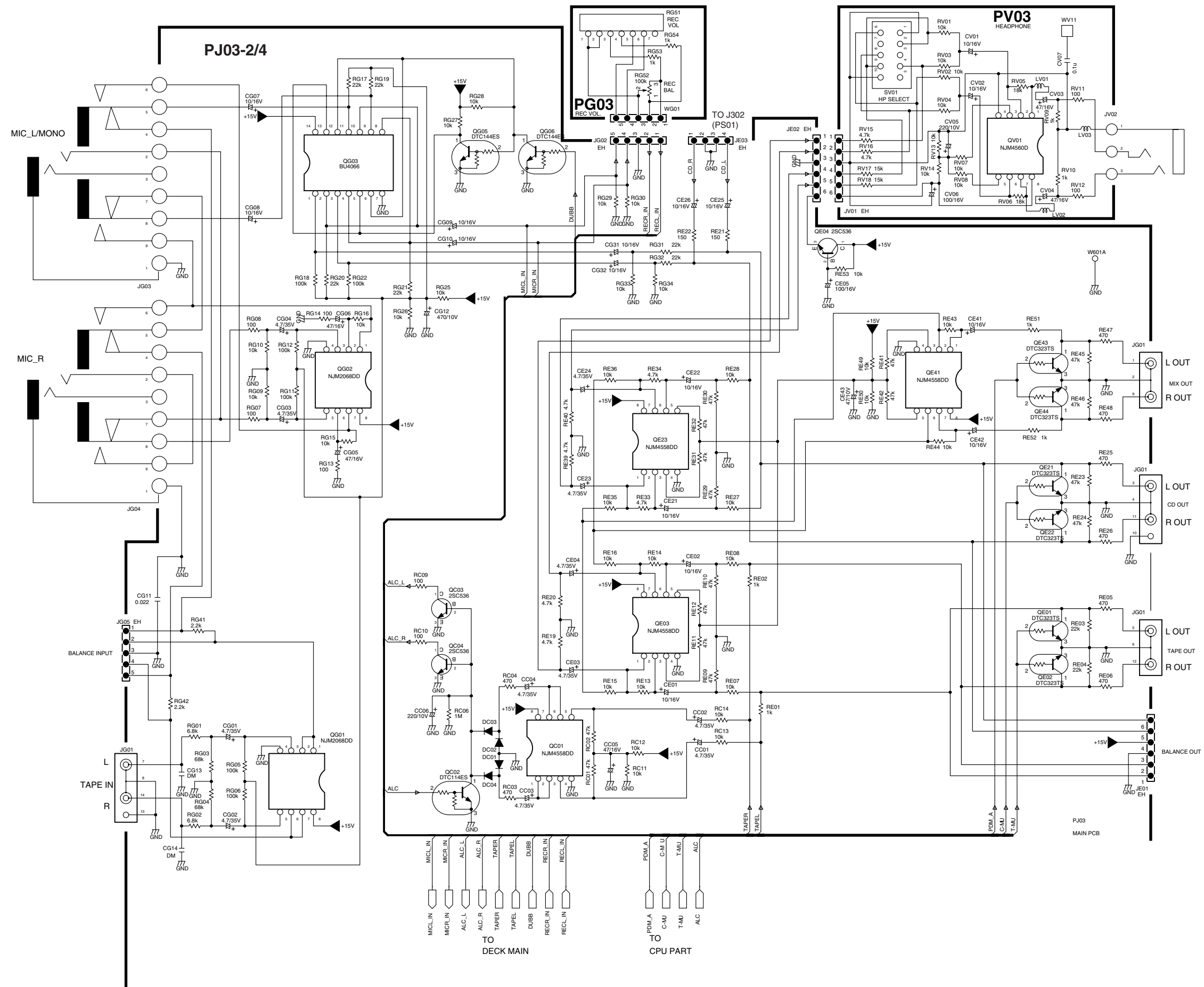

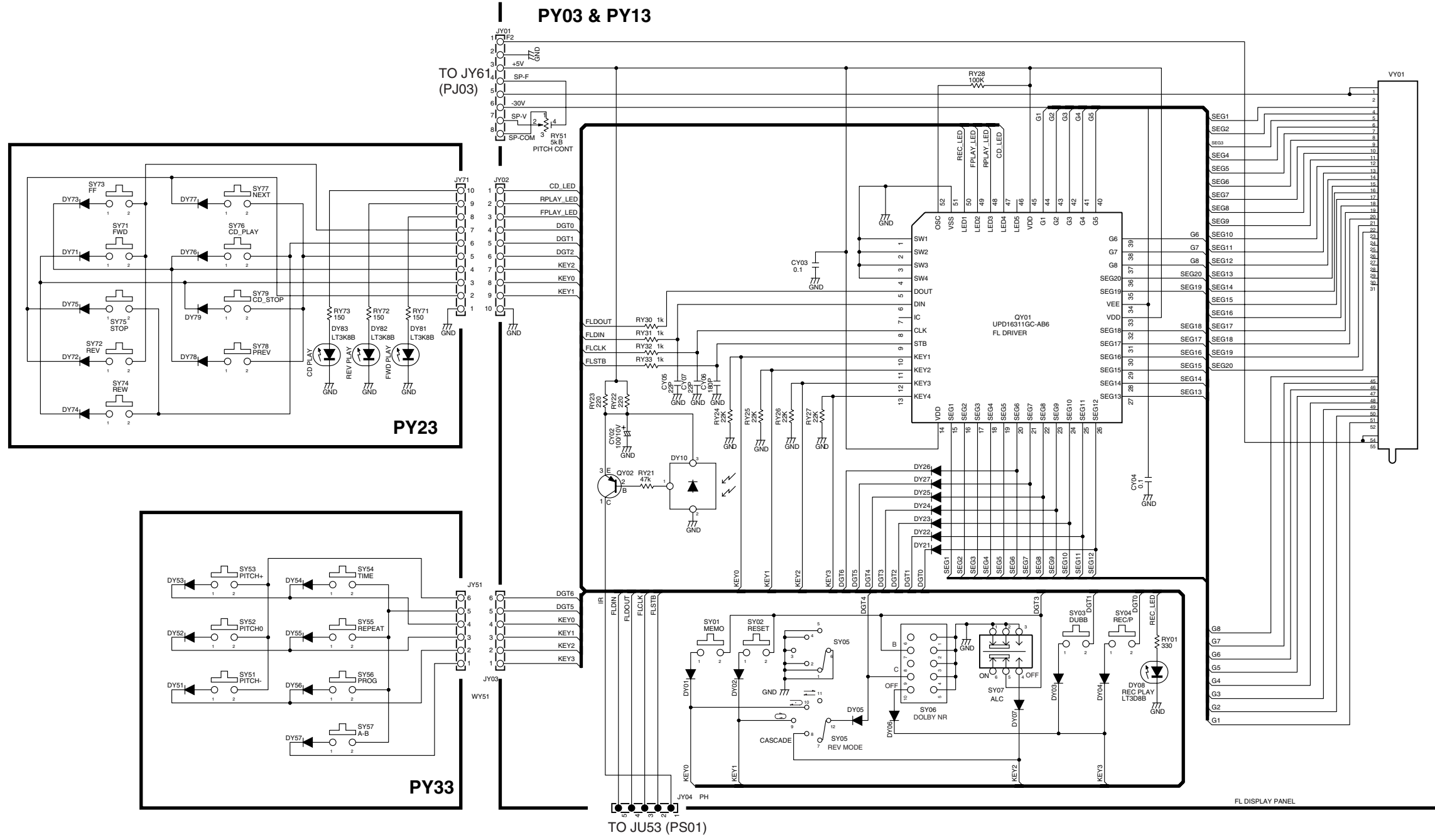

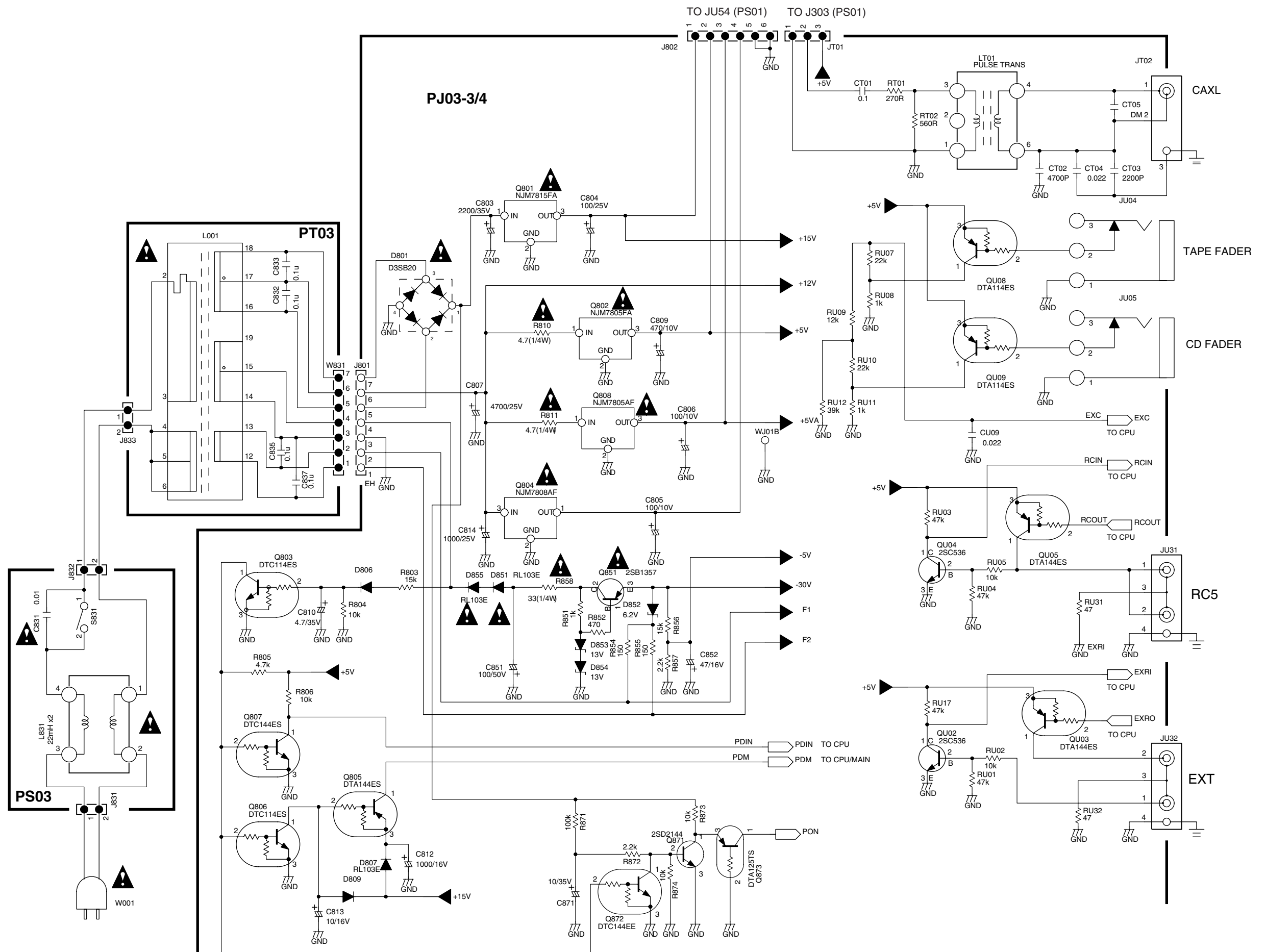

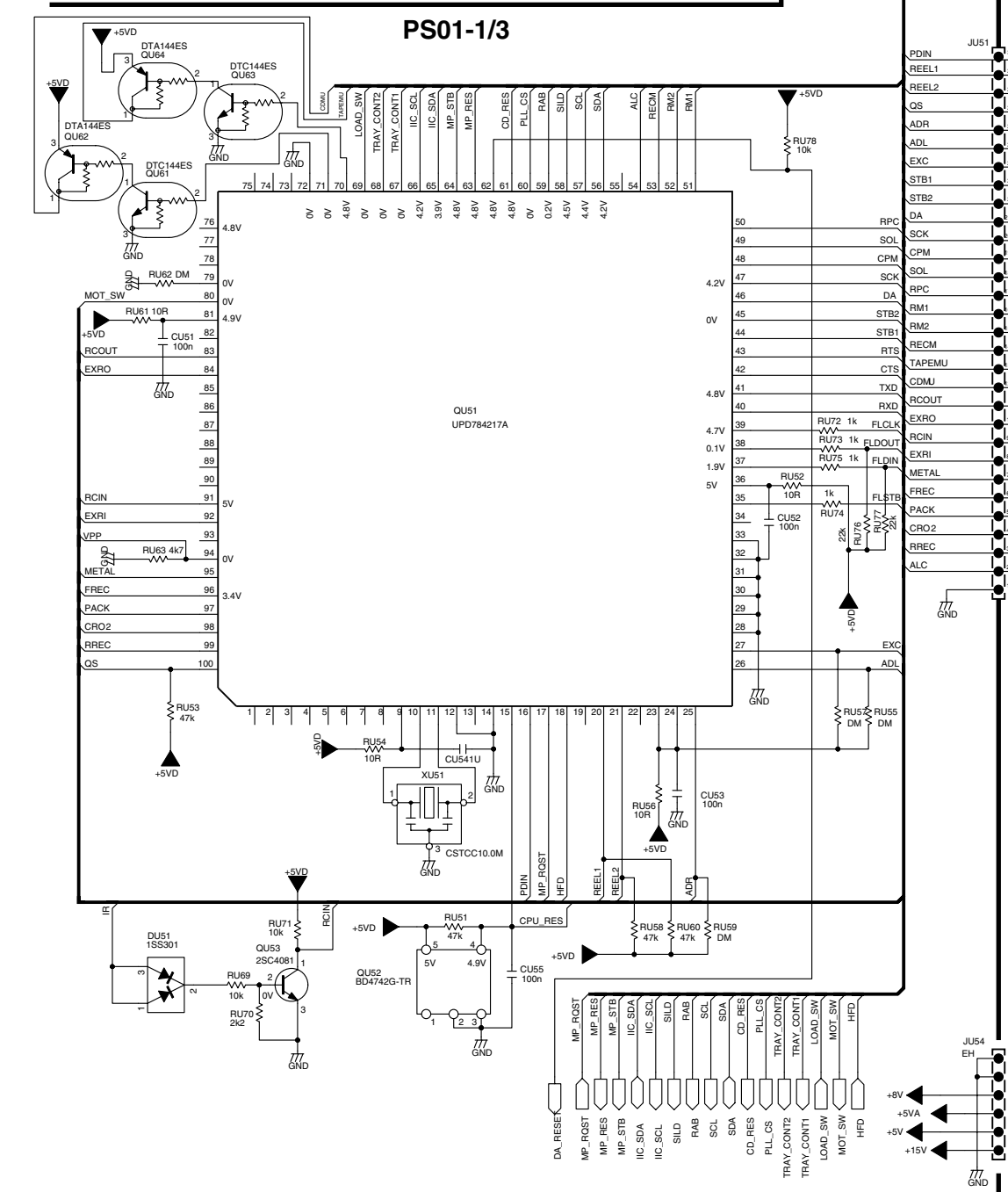
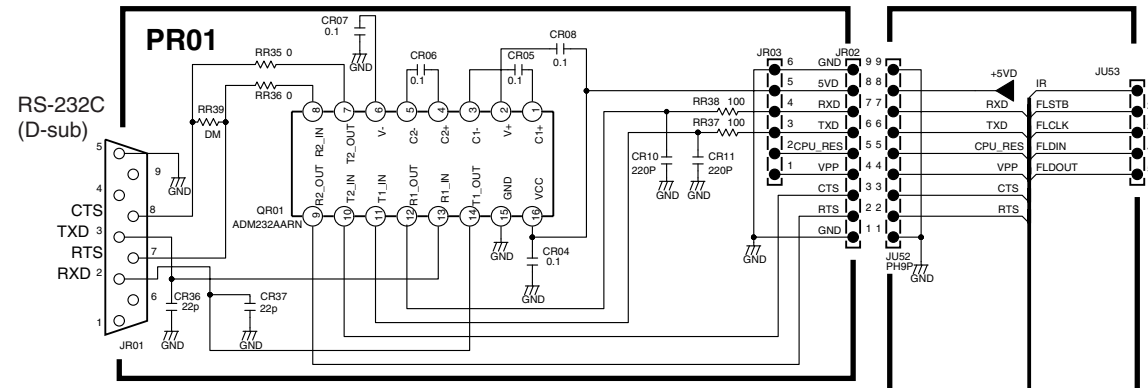

TO FRONT PART  
JY04 (PY13)

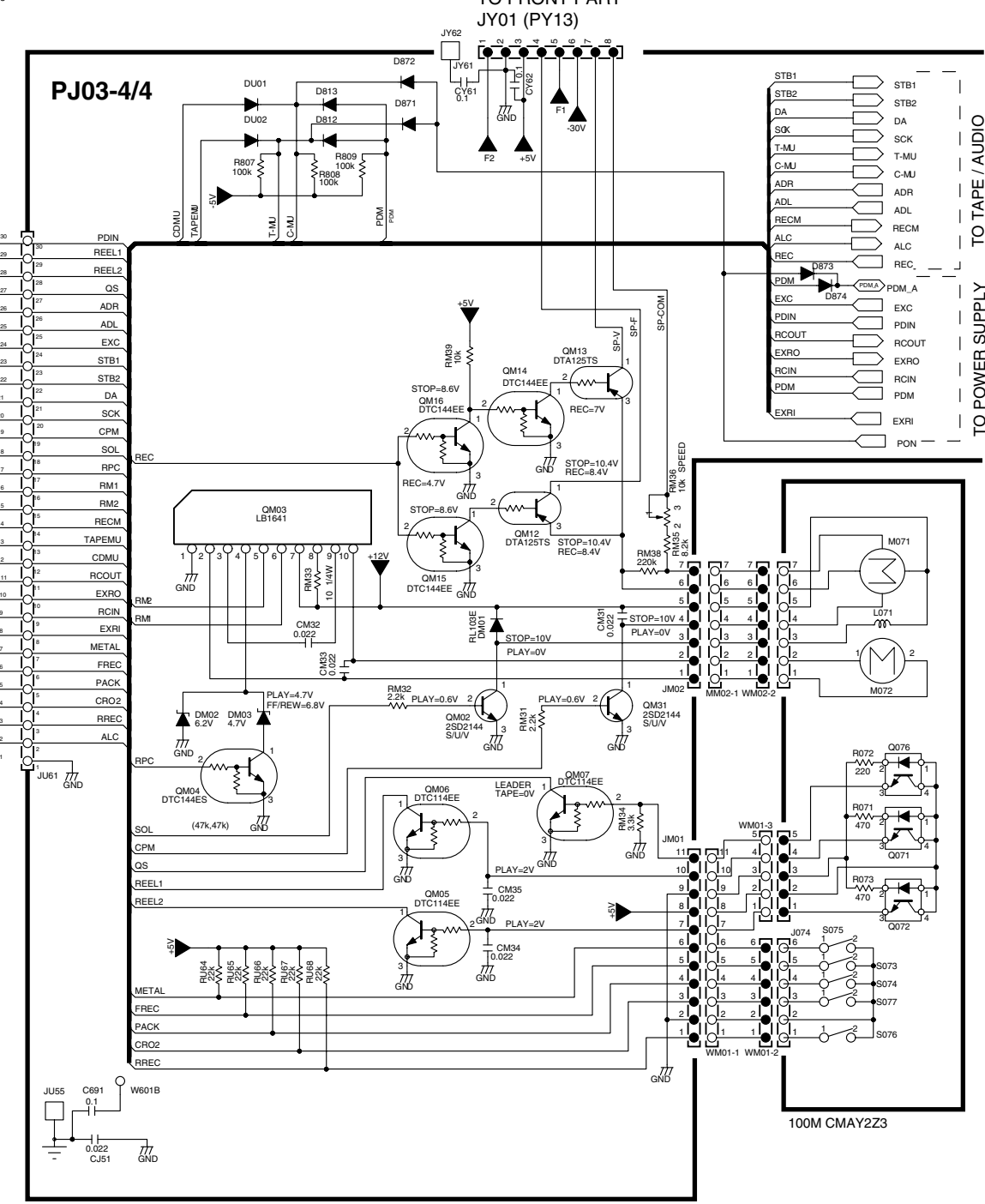

TO J802 (PJ03)



DM: DUMMY

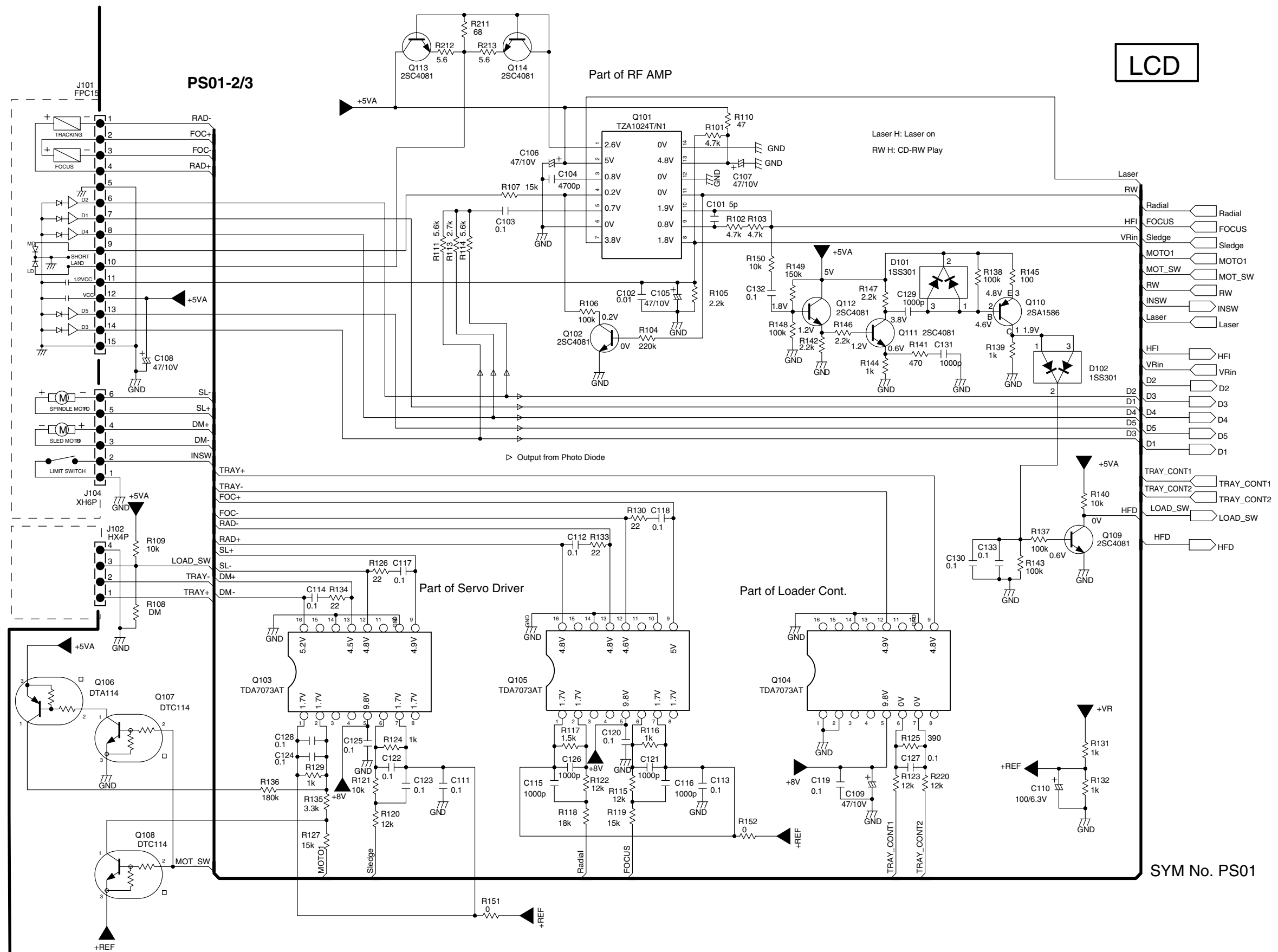

LCD

SYM No. PS01

DM: DUMMY



TO JT01 (PJ03)

PS01-3/3

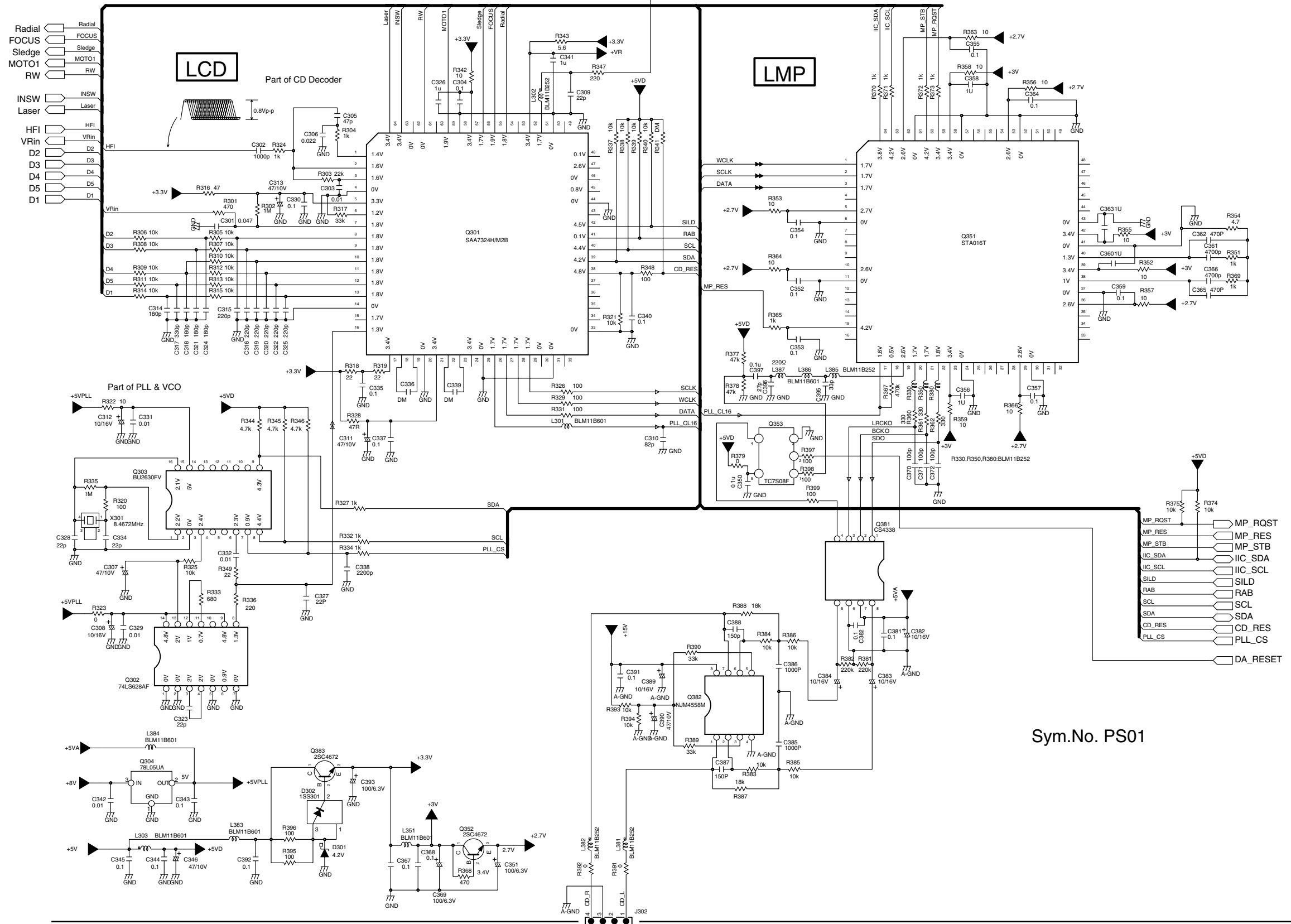

Sym.No. PS01

TO JE03 (PJ03)

11. PARTS LOCATION

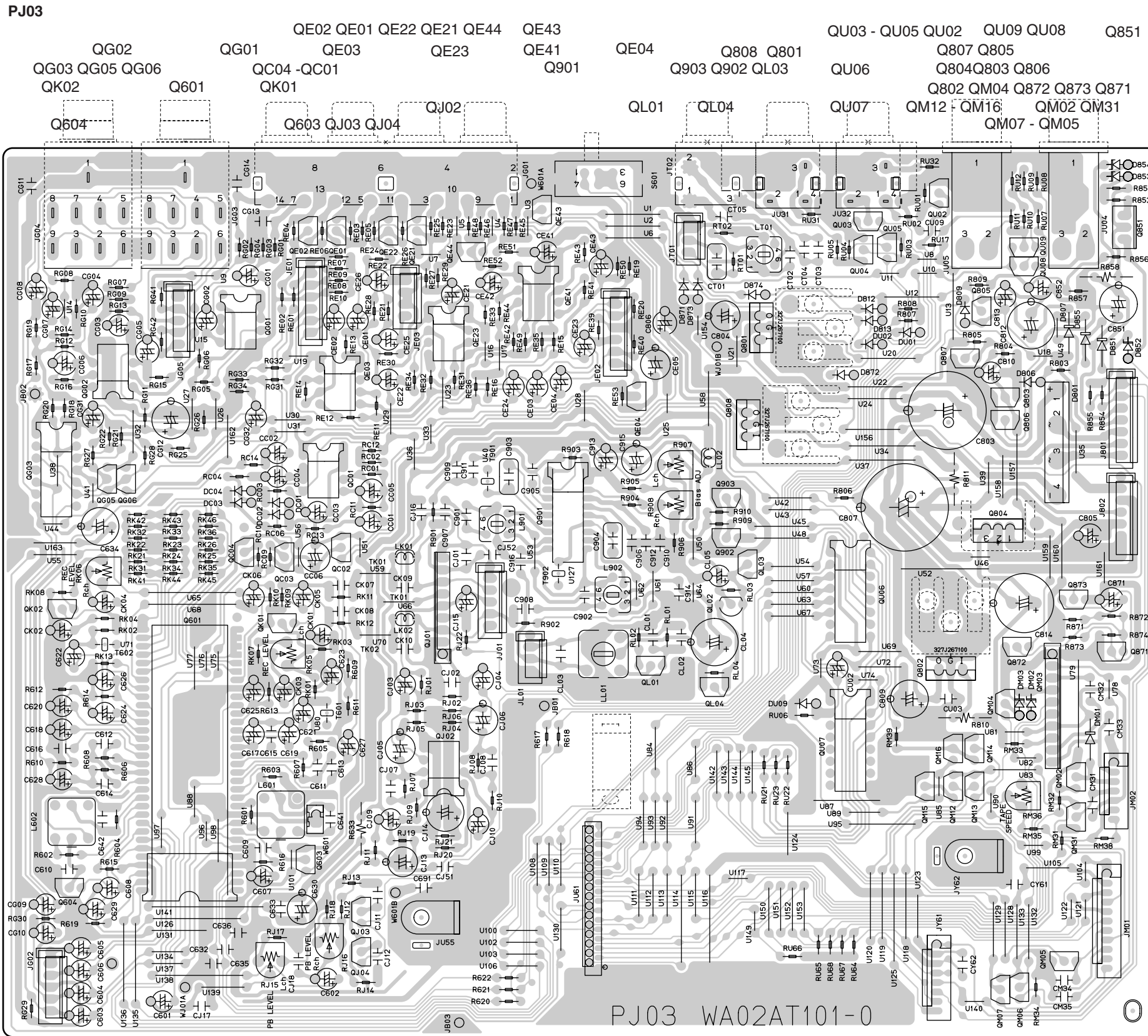

PY03, PY13  
QY02

QY01

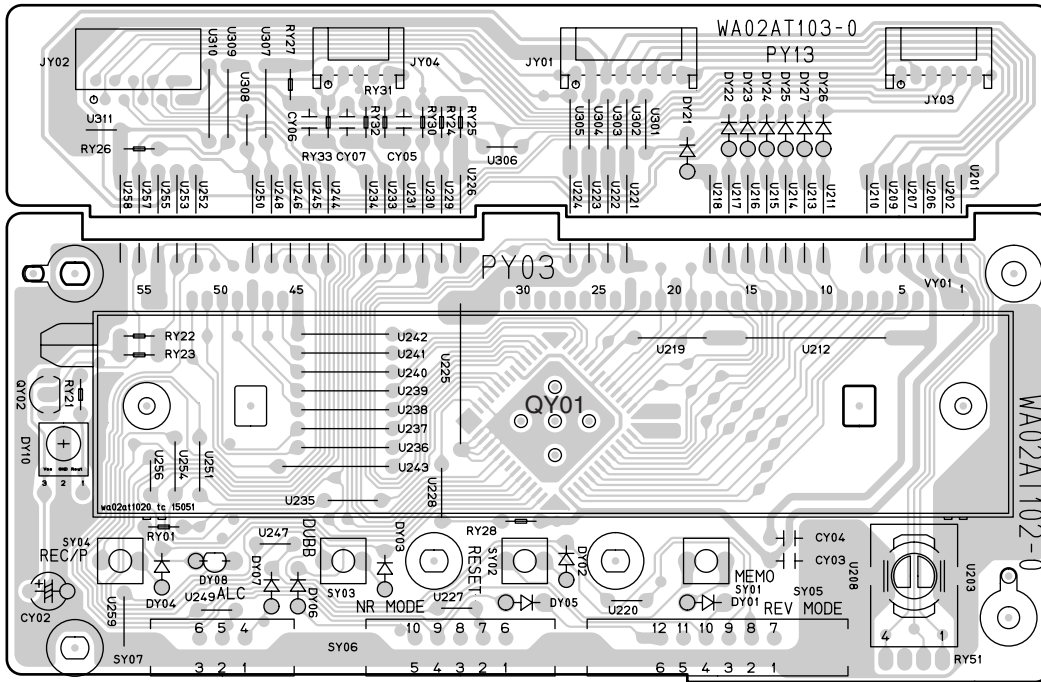

PY23

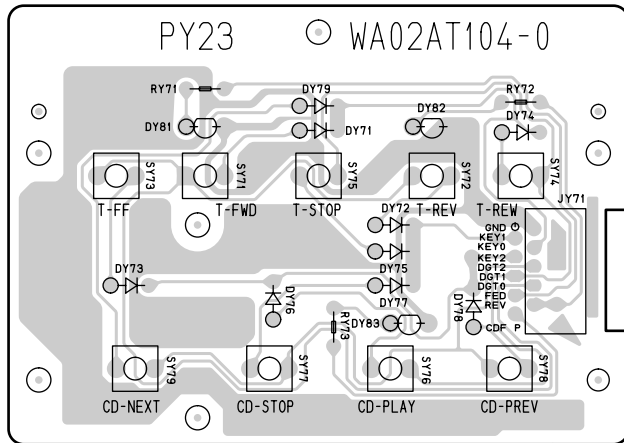

PY33

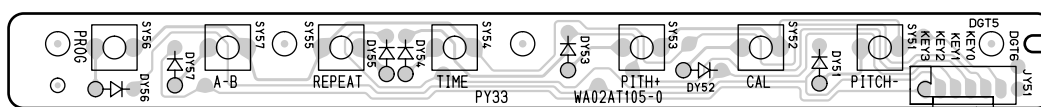

**PS03**

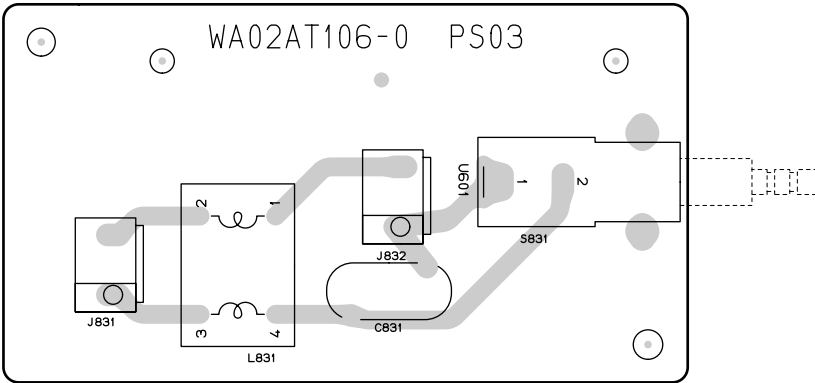

**PT03**

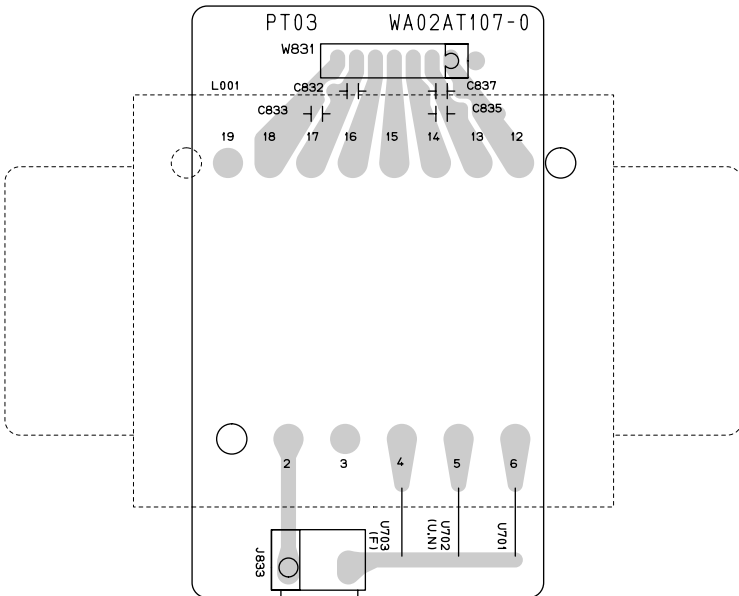

**PG03**

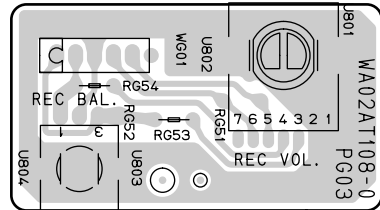

**PV03**

**QV01**

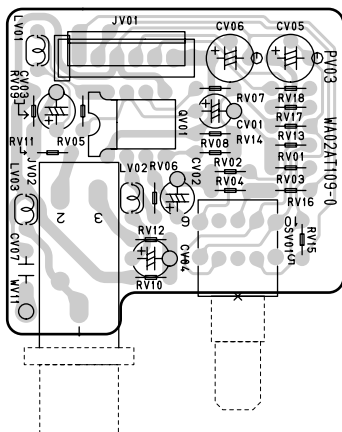

**PP01**

**QR01**

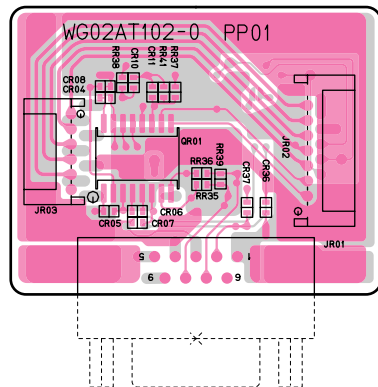

PS01

QU53 QU52

Q383 Q304 Q352

QU51 QU64 - QU61 Q111 Q112 Q101 Q102 Q113 Q114 Q106 Q107 Q104 Q103  
Q303 Q110 Q302 Q109 Q301 Q108 Q105

Q382

Q381

Q351

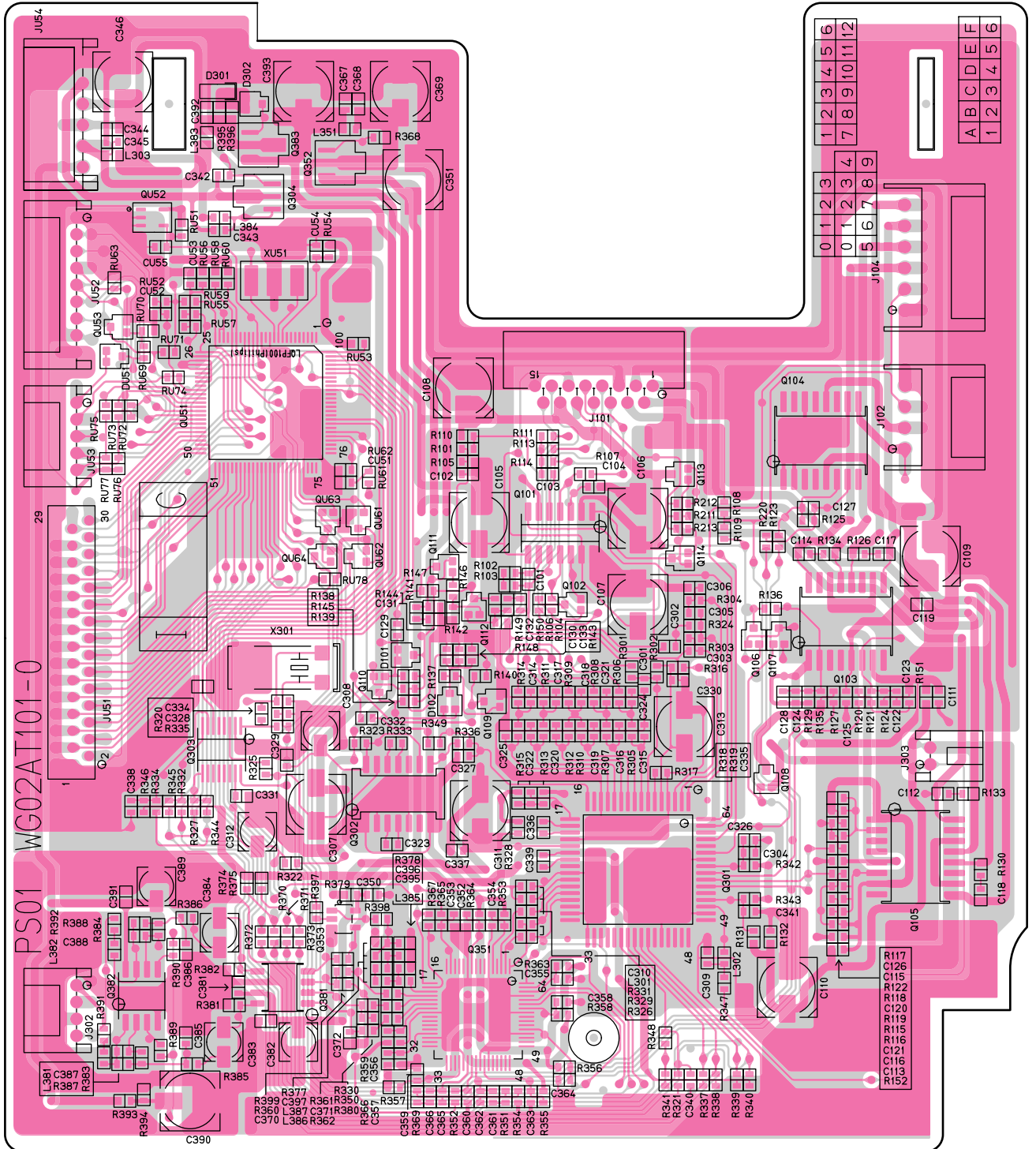

## 12. MICROPROCESSOR AND IC DATA

### Q303:BU2630FV

#### Pin descriptions

Pin No.	Pin name	Name	Function	I/O circuit
16	XOUT	Crystal resonator	For reference frequency	TYPE A
1	XIN			
2	V <sub>SS</sub>			
3	RPD	Phase comparator output	This is LO if the locally divided value is higher than the reference frequency, HI if it is lower, and Z if it matches.	TYPE E
4	P-R	Output port	This is controlled by the input data.	TYPE D
5	RON			
6	F-R	VCO input	Local input for reception	TYPE F
7	CE	Chip enable clock signal serial data	When CE is HIGH, the DA synchronized to the rise of CK is read into the internal shift register, and is latched at the timing of the CE fall.	TYPE B
8	CK			
9	DA			
10	LD	Unlock output	This goes ON when the PLL is unlocked on the transmission side	TYPE D
11	F-T	VCO input	Local input for transmission	TYPE F
12	TON	Output port	This is controlled by the input data	TYPE D
13	P-T			
14	TPD	Phase comparator output	This is LO if the locally divided value is higher than the reference frequency, HI if it is lower, and Z if it matches.	TYPE E
15	V <sub>DD</sub>	Power supply	2.5~5.5V	

### Q381:CS4338

SERIAL DATA INPUT	<b>SDATA</b>	1	8	<b>AOU<sub>L</sub></b>	ANALOG LEFT CHANNEL OUTPUT
DE-EMPHASIS / SCLK	<b>DEM/SCLK</b>	2	7	<b>VA</b>	ANALOG POWER
LEFT / RIGHT CLOCK	<b>LRCK</b>	3	6	<b>AGND</b>	ANALOG GROUND
MASTER CLOCK	<b>MCLK</b>	4	5	<b>AOU<sub>R</sub></b>	ANALOG RIGHT CHANNEL OUTPUT

No.	Pin Name	I/O	Pin Function and Description
1	SDATA	I	<b>Serial Audio Data Input</b> - two's complement MSB-first serial data is input on this pin. The data is clocked into the CS4334/5/8/9 via internal or external SCLK, and the channel is determined by LRCK.
2	DEM/SCLK	I	<b>De-Emphasis/External Serial Clock Input</b> - used for de-emphasis filter control or external serial clock input.
3	LRCK	I	<b>Left/Right Clock</b> - determines which channel is currently being input on the Audio Serial Data Input pin, SDATA.
4	MCLK	I	<b>Master Clock</b> - frequency must be 256x, 384x, or 512x the input sample rate in BRM and either 128x or 192x the input sample rate in HRM.
5	AOU <sub>R</sub>	O	<b>Analog Right Channel Output</b> - typically 3.5 Vp-p for a full-scale input signal.
6	AGND	I	<b>Analog Ground</b> - analog ground reference is 0V.
7	VA	I	<b>Analog Power</b> - analog power supply is nominally +5V.
8	AOU <sub>L</sub>	O	<b>Analog Left Channel Output</b> - typically 3.5 Vp-p for a full-scale input signal.

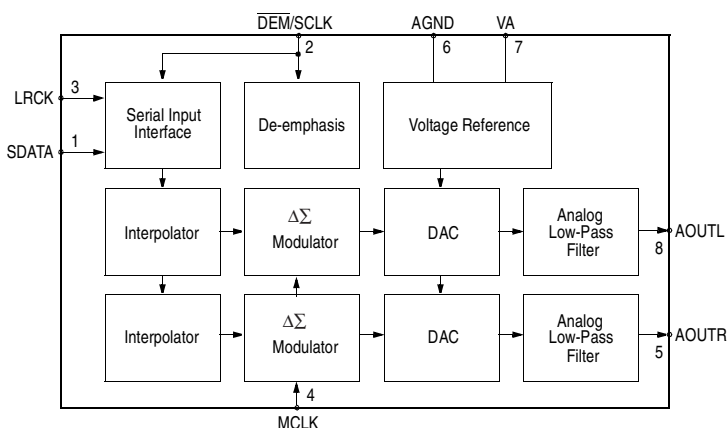

## Pin Description

PIN	Pin Name	Type	Description	Source/Dest
<b>CDDSP interface</b>				
1	CD_LRCK	I	DSP Interface left/right Clock	From DSP
3	CD_SDI	I	DSP interface serial data	From DSP
2	CD_BCK	I	DSP interface bit clock	From DSP
<b>SDI interface</b>				
9	BS_SDI	I	Bitstream interface serial data	From MCU
7	BS_LRCK	I	Bitstream interface left/right Clock	From MCU
8	BS_BCK	I	Bitstream interface clock	From MCU
4	DREQ	O	Bitstream data request	To MCU
<b>PCM IN interface</b>				
13	BCKI	I	ADC bit clock	From ADC
14	SDI	I	ADC serial data	From ADC
12	LRCKI	I	ADC left/right Clock	From ADC
<b>PCM OUT interface</b>				
20	LRCKO	O	DAC Interface left/right Clock	To DAC
22	SDO	O	DAC serial data	To DAC
21	BCKO	O	DAC bit clock	To DAC
19	OSCK	O	DAC oversampling clock	To DAC/ADC
<b>GPSO interface</b>				
55	GPSO_CK	I	GPSO bit clock	From MCU
54	GPSO_SDO	O	GPSO serial data	To MCU
56	GPSO_REQ	O	GPSO request signal	To MCU
<b>GPIO interface</b>				
26	IODATA0	I/O	GPIODATA0	
27	IODATA1	I/O	GPIODATA1	
28	IODATA2	I/O	GPIODATA2	
31	IODATA3	I/O	GPIODATA3	
32	IODATA4	I/O	GPIODATA4	
33	IODATA5	I/O	GPIODATA5	
34	IODATA6	I/O	GPIODATA6	
35	IODATA7	I/O	GPIODATA7	
44	IODATA8	I/O	GPIODATA8	
45	IODATA9	I/O	GPIODATA9	
46	IODATA10	I/O	GPIODATA10	
47	IODATA11	I/O	GPIODATA11	
48	IODATA12	I/O	GPIODATA12	
49	IODATA13	I/O	GPIODATA13	
50	IODATA14	I/O	GPIODATA14	
51	IODATA15	I/O	GPIODATA15	

Q351:STA016

PIN	Pin Name	Type	Description	Source/Dest
<b>HANDSHAKE SIGNALS</b>				
60	STB	I	Strobe signal	From MCU
59	RQST	O	I2C data signal	To MCU
<b>I<sup>2</sup>C LINK</b>				
63	SCL	I	I2C clock signal	From MCU
64	SDA	I/O	I2C data signal	To MCU
<b>MISCELLANEOUS</b>				
17	XTI	I	Oscillator input	
18	XTO	O	Oscillator output	
25	CLKOUT	O	Buffered output clock	
15	RESET	I	Reset	
16	TESTEN	I	Reserved for test purpose	
40	FILT0	I	PLL external filter	
38	FILT1		PLL external filter	
<b>POWER SUPPLY</b>				
39	PLL_VCC			
41	PLL_GND			
5	VDD_1		Digital supply (2.5V Power Supply)	
10	VDD_2		Digital supply (2.5V Power Supply)	
29	VDD_3		Digital supply (2.5V Power Supply)	
36	VDD_4		Digital supply (2.5V Power Supply)	
53	VDD_5		Digital supply (2.5V Power Supply)	
62	VDD_6		Digital supply (2.5V Power Supply)	
23	VCC_1		Digital supply (3.3V Power Supply)	
42	VCC_2		Digital supply (3.3V Power Supply)	
58	VCC_3		Digital supply (3.3V Power Supply)	
6	VSS_1			
11	VSS_2			
24	VSS_3			
30	VSS_4			
37	VSS_5			
43	VSS_6			
52	VSS_7			
57	VSS_8			
61	VSS_9			

Pin Assignment

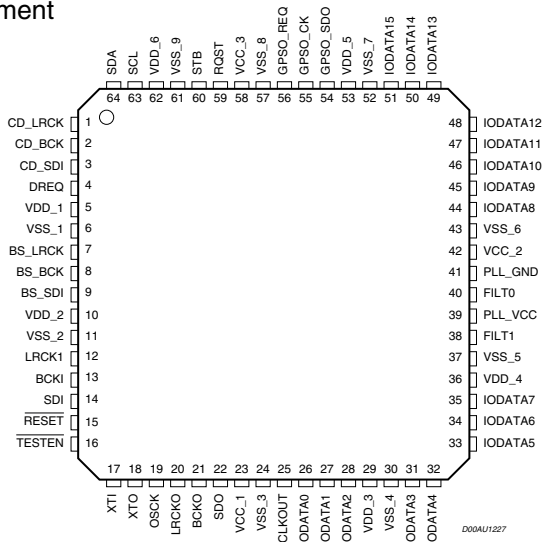



QR01 : HIN202ECB

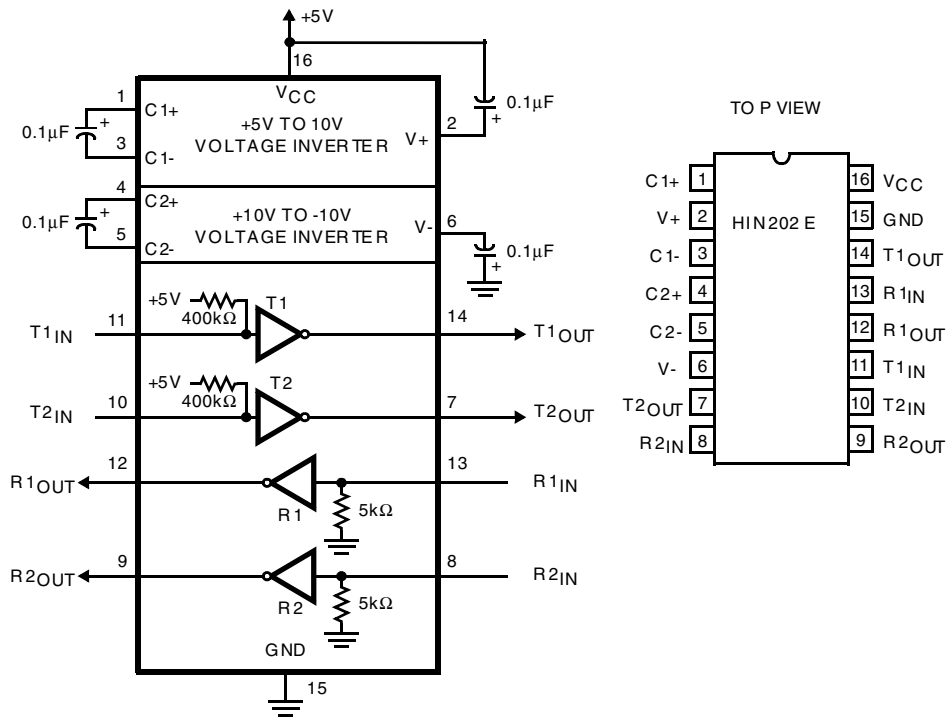

Pin Descriptions

PIN	FUNCTION
V <sub>CC</sub>	Power Supply Input 5V ±10%.
V+	Internally generated positive supply (+10V nominal).
V-	Internally generated negative supply (-10V nominal).
GND	Ground Lead. Connect to 0V.
C1+	External capacitor (+ terminal) is connected to this lead.
C1-	External capacitor (- terminal) is connected to this lead.
C2+	External capacitor (+ terminal) is connected to this lead.
C2-	External capacitor (- terminal) is connected to this lead.
T <sub>IN</sub>	Transmitter Inputs. These leads accept TTL/CMOS levels. An internal 400kΩ pull-up resistor to V <sub>CC</sub> is connected to each lead.
T <sub>OUT</sub>	Transmitter Outputs. These are RS-232 levels (nominally ±10V).
R <sub>IN</sub>	Receiver Inputs. These inputs accept RS-232 input levels. An internal 5kΩ pull-down resistor to GND is connected to each input.
R <sub>OUT</sub>	Receiver Outputs. These are TTL/CMOS levels.
EN, EN	Receiver Enable Input. With EN = 5V (HIN213E EN=0V), the receiver outputs are placed in a high impedance state.
SD, SD	Shutdown Input. With SD = 5V (HIN213E SD = 0V), the charge pump is disabled, the receiver outputs are in a high impedance state (except for R4 and R5 of HIN213E) and the transmitters are shut off.
NC	No Connect. No connections are made to these leads.

**Q301:SAA7324**

Pin Description

SYMBOL	PIN	DESCRIPTION
HFREF	1	comparator common mode input
HFIN	2	comparator signal input
ISLICE	3	current feedback output from data slicer
V <sub>SSA1</sub>	4 <sup>(1)</sup>	analog ground 1
V <sub>DDA1</sub>	5 <sup>(1)</sup>	analog supply voltage 1
I <sub>ref</sub>	6	reference current output pin
V <sub>RIN</sub>	7	reference voltage for servo ADC's
D1	8	unipolar current input (central diode signal input)
D2	9	unipolar current input (central diode signal input)
D3	10	unipolar current input (central diode signal input)
D4	11	unipolar current input (central diode signal input)
R1	12	unipolar current input (satellite diode signal input)
R2	13	unipolar current input (satellite diode signal input)
V <sub>SSA2</sub>	14 <sup>(1)</sup>	analog ground 2
CROUT	15	crystal/resonator output
CRIN	16	crystal/resonator input
V <sub>DDA2</sub>	17 <sup>(1)</sup>	analog supply voltage 2
LN	18	DAC left channel differential output - negative
LP	19	DAC left channel differential output - positive
V <sub>neg</sub>	20 <sup>(1)</sup>	DAC negative reference supply (equivalent to DAC V <sub>SS</sub> )
V <sub>pos</sub>	21 <sup>(1)</sup>	DAC positive reference supply (equivalent to DAC V <sub>DD</sub> )
RN	22	DAC right channel differential output - negative
RP	23	DAC right channel differential output - positive
SELPLL	24	selects whether internal clock multiplier PLL is used
TEST1	25	test control input 1; this pin should be tied LOW
CL16	26	16.9344 MHz system clock output
DATA	27	serial data output (3-state)
WCLK	28	word clock output (3-state)
SCLK	29	serial bit clock output (3-state)
EF	30	C2 error flag output (3-state)
TEST2	31	test control input 2; this pin should be tied LOW
KILL	32	kill output (programmable; open-drain)
V <sub>SSD1</sub>	33 <sup>(1)</sup>	digital ground 2
V2/V3	34	versatile I/O: input versatile pin 2 or output versatile pin 3 (open-drain)
WCLI	35	word clock input (for data loopback to DAC)
SDI	36	serial data input (for data loopback to DAC)
SCLI	37	serial bit clock input (for data loopback to DAC)
RESET	38	power-on reset input (active LOW)
SDA	39	microcontroller interface data I/O line (open-drain output)
SCL	40	microcontroller interface clock line input
RAB	41	microcontroller interface R $\bar{W}$ and load control line input (4-wire bus mode)
SILD	42	microcontroller interface $\bar{R}W$ and load control line input (4-wire bus mode)
STATUS	43	servo interrupt request line/decoder status register output (open-drain)
TEST3	44	test control input 3; this pin should be tied LOW
RCK	45	subcode clock input
SUB	46	P-to-W subcode bits output (3-state)
SFSY	47	subcode frame sync output (3-state)
SBSY	48	subcode block sync output (3-state)
CL11/4	49	11.2896 MHz or 4.2336 MHz (for microcontroller) clock output
V <sub>SSD2</sub>	50 <sup>(1)</sup>	digital ground 3
DOBM	51	bi-phase mark output (externally buffered; 3-state)
V <sub>DD1(P)</sub>	52 <sup>(1)</sup>	digital supply voltage 2 for periphery
CFLG	53	correction flag output (open-drain)
RA	54	radial actuator output
FO	55	focus actuator output
SL	56	sledge control output
V <sub>DD2(C)</sub>	57 <sup>(1)</sup>	digital supply voltage 3 for core
V <sub>SSD3</sub>	58 <sup>(1)</sup>	digital ground 4
MOTO1	59	motor output 1; versatile (3-state)
MOTO2	60	motor output 2; versatile (3-state)
V4	61	versatile output pin 4
V5	62	versatile output pin 5
V1	63	versatile input pin 1
LDON	64	laser drive on output (open-drain)

**Note**

1. All supply pins must be connected to the same external power supply voltage

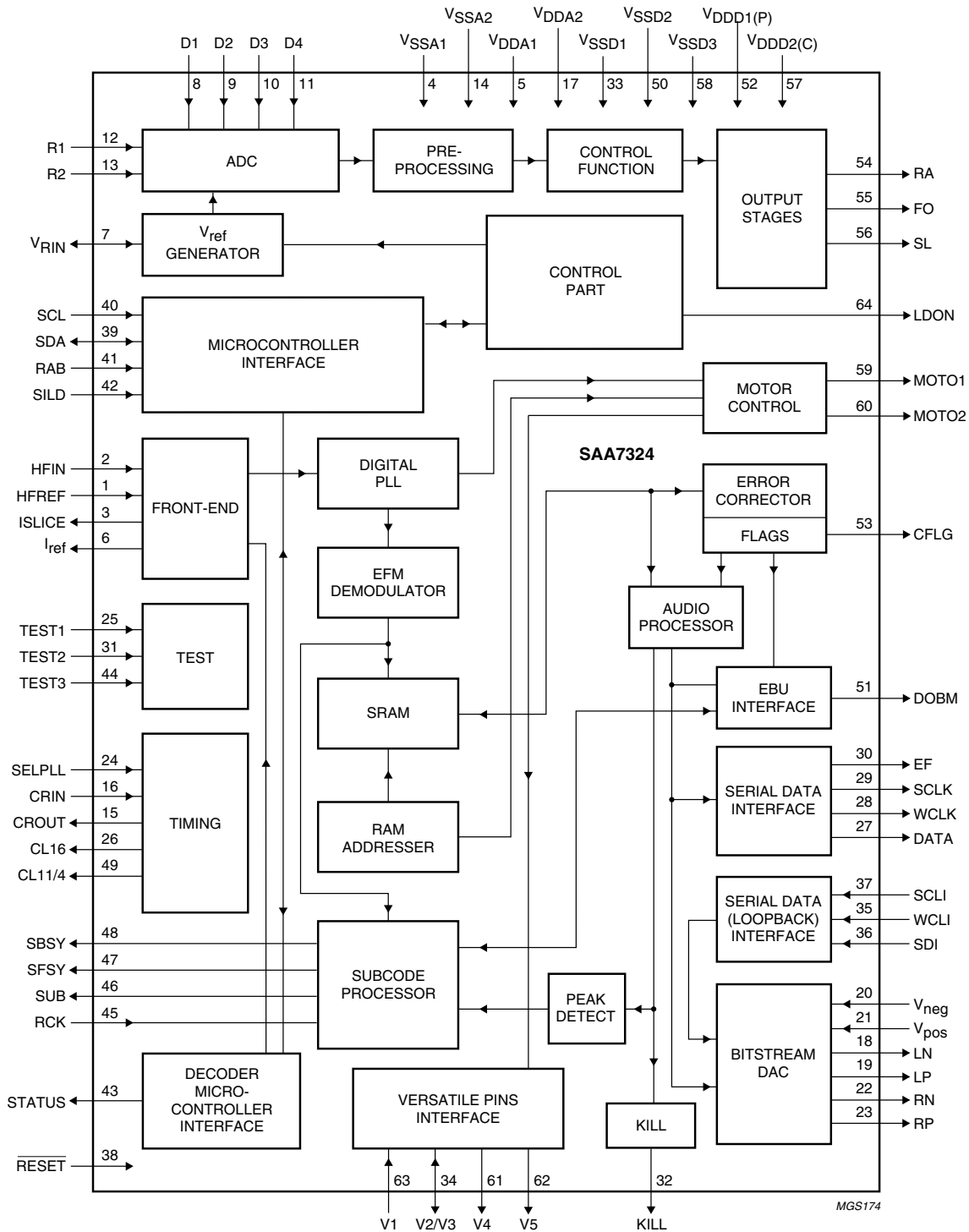

QU51 :  $\mu$ PD784217AGC-192-8EU

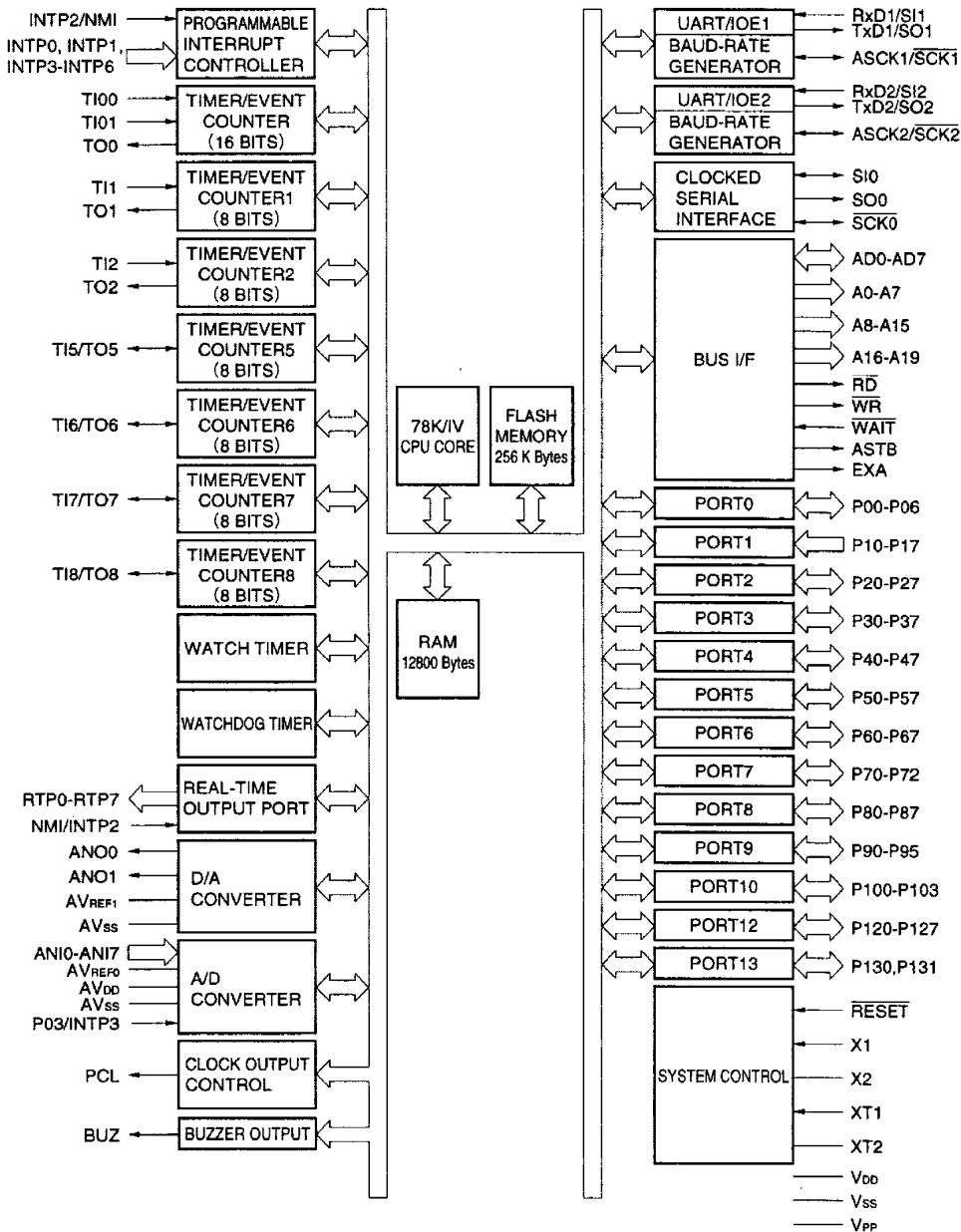
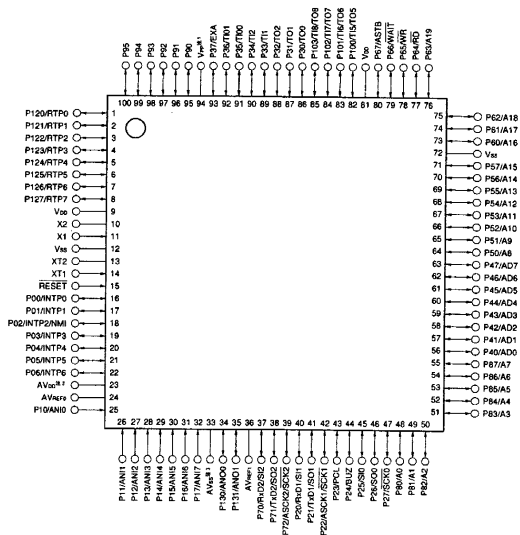

QU51 :  $\mu$ PD784217AGC-192-8EU

Pin No.	Port Name	I/O	Signal Name	Remarks
1	P120/RTP0	O	n.c.	n.c.
2	P121/RTP1	O	n.c.	n.c.
3	P122/RTP2	O	n.c.	n.c.
4	P123/RTP3	O	n.c.	n.c.
5	P124/RTP4	O	n.c.	n.c.
6	P125/RTP5	O	n.c.	n.c.
7	P126/RTP6	O	n.c.	n.c.
8	P127/RTP7	O	n.c.	n.c.
9	VDD		+5V	Power +5V
10	X2	O	10MHz	Main system clock 10MHz
11	X1	I	10MHz	Main system clock 10MHz
12	VSS		GND	GND
13	XT2		n.c.	n.c.
14	XT1		GND	GND
15	RESET	I	CPU_RES	Reset active low
16	P00/INTP0	I	PDIN	Power down in (active Low)
17	P01/INTP1	I	MP_RQST	From STA016T
18	P02/INTP2/NMI	I	HFD	From HF Detector
19	P03/INTP3	I	n.c.	n.c.
20	P04/INTP4	I	REEL1	Reel pulse1 from tape deck
21	P05/INTP5	I	REEL2	Reel pulse2 from tape deck
22	P06/INTP6	I	n.c.	n.c.
23	AVDD		+5V	Power +5V
24	AVREF0		+5V	A/D reference
25	P10/ANI0	I	ADR	A/D tape Rch level meter
26	P11/ANI1	I	ADL	A/D tape Lch level meter
27	P12/ANI2	I	EXC	A/D fader selection
28	P13/ANI3	I	GND	GND
29	P14/ANI4	I	GND	GND
30	P15/ANI5	I	GND	GND
31	P16/ANI6	I	GND	GND
32	P17/ANI7	I	GND	GND
33	AVSS		GND	GND
34	P130/ANO0	O	n.c.	n.c.
35	P131/ANO1	O	FL_STB	Strobe for uPD161311
36	AVREF1		+5V	D/A reference
37	P70/RXD2/SI2	O	FL_DIN	Data in from uPD161311
38	P71/TXD2/SO2	O	FL_DOUT	Data out for uPD161311
39	P72/ASCK2/SCK2	O	FL_CLK	Clock for uPD161311
40	P20/RXD1/SI1	I	RXD	For 232C interface
41	P21/TXD1/SO1	O	TXD	For 232C interface
42	P22/ASCK1/SCK1	O	CTS	For 232C interface
43	P23/PCL	O	RTS	For 232C interface
44	P24/BUZ	O	STB1	Strobe1 for 74HC4094(Ext.port)
45	P25/SI0/SDA0	O	STB2	Strobe2 for HA12155NT(DolbyIC)
46	P26/SO0	O	DA	Data out for HA12155/74HC4094
47	P27/SCK0/SCL0	O	SCK	Clock for HA12155/74HC4094
48	P80/A0	O	CPM	Capstan motor on/off
49	P81/A1	O	SOL	Solenoid on/off
50	P82/A2	O	RPC	Reel speed high/low

Pin No.	Port Name	I/O	Signal Name	Remarks
51	P83/A3	O	RM1	Reel motor1 on/off
52	P84/A4	O	RM2	Reel motor2 on/off
53	P85/A5	O	RECM	Rec mute. For HA12155
54	P86/A6	O	ALC	ALC On=LOW, Off=HIGH
55	P87/A7	O	n.c.	n.c.
56	P40/AD0	I/O	CD_SDA	Data for CD10/BU2630
57	P41/AD1	O	CD_SCL	Clock for CD10/BU2630
58	P42/AD2	O	CD_SILD	Latch for CD10 servo part
59	P43/AD3	O	CD_RAB	Latch for CD10 decoder part
60	P44/AD4	O	PLL_CS	CS for BU2630
61	P45/AD5	O	CD_RES	Reset for CD10
62	P46/AD6	O	n.c.	n.c.
63	P47/AD7	O	MP_RES	Reset for STA016T
64	P50/A8	O	MP_STB	Strobe for STA016T
65	P51/A9	I/O	IIC_SDA	Data for STA016T
66	P52/A10	O	IIC_SCL	Clock for STA016T
67	P53/A11	O	TRAY_CONT1	Tray in/out control
68	P54/A12	O	TRAY_CONT2	Tray in/out control
69	P55/A13	I	LOAD_SW	Tray loading sw Low active
70	P56/A14	O	TAPEMU	Tape mute cont.
71	P57/A15	O	CDMU	CD mute cont.
72	VSS		GND	GND
73	P60/A16	O	n.c.	n.c.
74	P61/A17	O	n.c.	n.c.
75	P62/A18	O	n.c.	n.c.
76	P63/A19	O	n.c.	n.c.
77	P64/RD	O	n.c.	n.c.
78	P65/WR	O	n.c.	n.c.
79	P66/WAIT	I	MP3_EN	MP3 Enable = OpenMP3 Disable = Low
80	P67/ASTB	O	MOT_SW	Spindle Free RUN Active HIGH
81	VDD		+5V	Power +5V
82	P100/TI5/TO5	O	n.c.	n.c.
83	P101/TI6/TO6	O	RCOUT	RC5 out
84	P102/TI7/TO7	O	EXRO	External RC out
85	P103/TI8/TO8	O	n.c.	n.c.
86	P30/TO0	O	n.c.	n.c.
87	P31/TO1	O	n.c.	n.c.
88	P32/TO2	O	n.c.	n.c.
89	P33/TI1	O	n.c.	n.c.
90	P34/TI2	O	n.c.	n.c.
91	P35/TI00	I	RCIN	RC5 in
92	P36/TI01	I	EXRI	External RC in
93	P37/EXA	O	n.c.	n.c.
94	TEST		GND	GND
95	P90	I	METAL	From tape deck sw
96	P91	I	FREC	From tape deck sw
97	P92	I	PACK	From tape deck sw
98	P93	I	CRO2	From tape deck sw
99	P94	I	RREC	From tape deck sw
100	P95	I	QS	Quick Sensor from tape deck

### 13. EXPLODED VIEW AND PARTS LIST

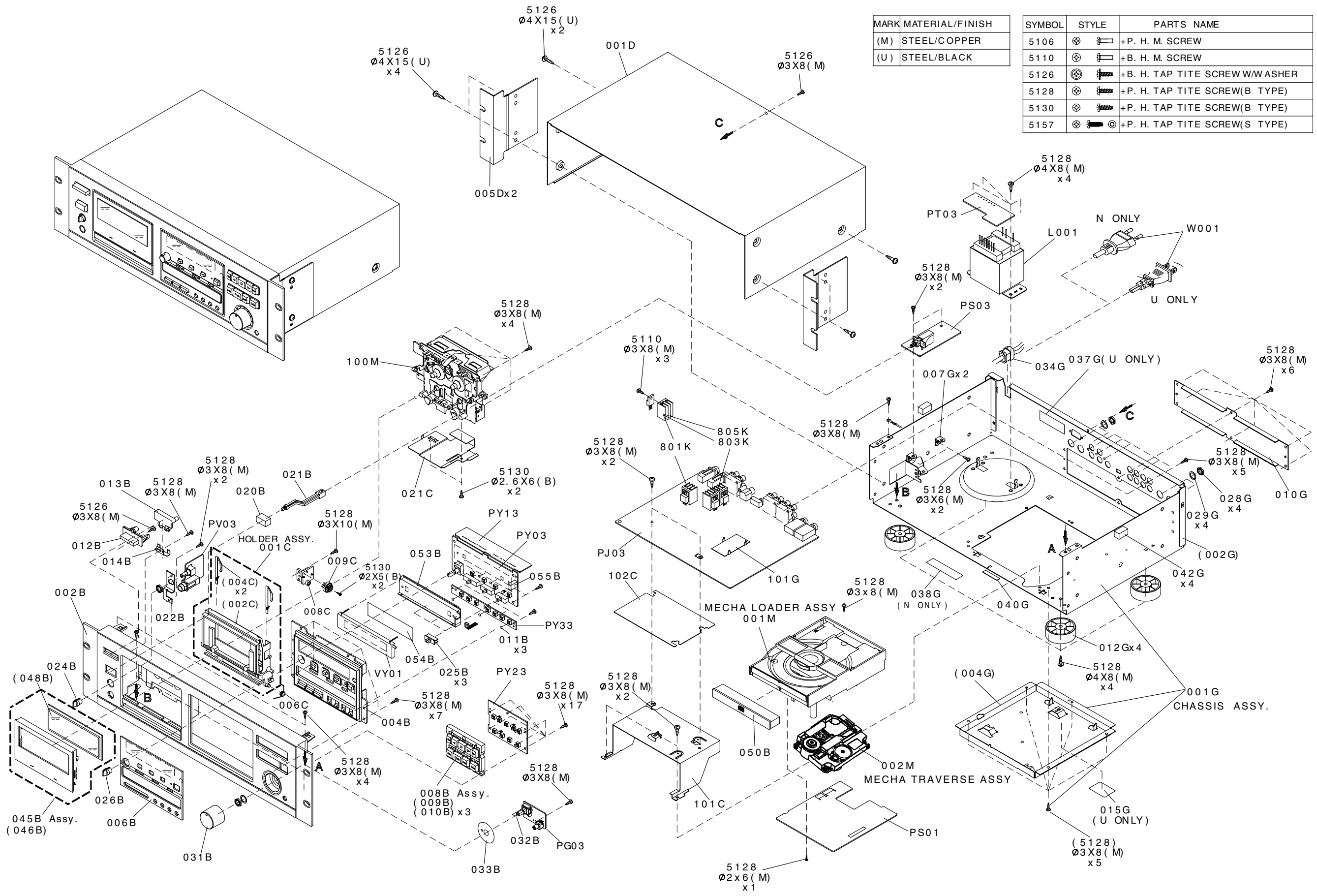

MARK	MATERIAL/FINISH	SYMBOL	STYLE	PARTS NAME
(M)	STEEL/COPPER			+P. H. M. SCREW
(U)	STEEL/BLACK			+B. H. M. SCREW
				+B. H. TAP TITE SCREW W/WASHER
				+P. H. TAP TITE SCREW(B TYPE)
				+P. H. TAP TITE SCREW(B TYPE)
				+P. H. TAP TITE SCREW(S TYPE)

POS. NO	VERS. COLOR	PART NO. (FOR EUR)	DESCRIPTION	PART NO. (MJI)
002B		474T248110	FRONT PANEL	474T248110
004B		474T053010	COVER	474T053010
006B		474T158020	WINDOW	474T158020
008B		474T270500	MECHA BUTTON K	474T270500
009B		474T270010	MECHA BUTTON	474T270010
010B		474T355010	LENS (PLAY)	474T355010
012B		416T270040	EJECT BUTTON FOR FRONT PANEL	416T270040
013B		416T354010	EJECT LEVER FOR FRONT PANEL	416T354010
020B		023J270020	POWER BUTTON	023J270020
021B		416T121010	POWER SW LINK	416T121010
024B		284T154310	HP SW KNOB	284T154310
025B		453T154010	SLIDE KNOB	453T154010
026B		284T154310	PITCH KNOB	284T154310
031B		431T154010	REC LEVEL KNOB	431T154010
045B		457T053500	CASSETTE COVER K	457T053500
050B		02AT063010	ESCUTCHEON CD	02AT063010
001C		416T271500	CASSETTE HOLDER K	416T271500
002C		415T271020	CASSETTE HOLDER	415T271020
004C		416T116020	LEAF SPRING FOR CLAMPER	416T116020
006C		420T115030	CASSETTE HOLDER OPEN SPRING	420T115030
009C		415T130010	GEAR DAMPER	415T130010
012G		176H057630	LEG FOR MAIN CHASSIS	176H057630
028G		075S011010	NUT FOR JACK D:6.4	075S011010
001M		05AK304500	MECHA LOADER ASSY VAL2212 08	05AK304500
002M		05AK304510	MECHA TRAVERSE ASSY VAM2202 08	05AK304510
W001	/N	YC01800790	MAINS CORD N (MAYOR)	YC01800790
W001	/U		MAINS CORD UL/CSA NON-INTEGRAL	YC02000880
WU03		nsp	JUMPER LEAD JU61-JU51 U-CON CONTROL	YU30230520
WY02		nsp	JUMPER LEAD JY02-JY71 CD/TAPE CONTROL	YU10110500
001T		02AT851250	<b>PACKING</b> USER GUIDE PMD351	02AT851250
004T		02AT851020	USER GUIDE CD-ROM	02AT851020
001S		nsp	<b>NOT STANDARD SPARE PARTS</b> PACKING CASE	02AT801010
002S		nsp	CUSHION	457T809010
001D		nsp	LID TOP COVER	418T257030
005D		nsp	SIDE BRACKET (L&R)	457T160110

NOTE : "nsp" PART IS LISTED FOR REFERENCE ONLY, MARANTZ WILL NOT SUPPLY THESE PARTS.

POS. NO	VERS. COLOR	PART NO. (FOR EUR)	DESCRIPTION	PART NO. (MJI)
100M		466T304500	MECHANISM ASSY CMAY2Z3	466T304500
102M		nsp	MECHA BRACKET (L) [FC53D-22]	415T160020
104M		nsp	MECHA BRACKET (R) [FC53E-12]	415T160030
106M		nsp	STOPPER FOR EJECT [FD46H-12]	415T114010
110M		nsp	EJECT HOOK LEVER [FC49P-91]	415T258310
113M		nsp	SCREW [UG14M-31]	415T010010
114M		nsp	SPRING (LEFT-SIDE) [FK23R-11]	415T115040
125M		nsp	MOLD HOOK [FD35W-11]	415T258020
151M		456T001050	IDLER [F517-049]	456T001050
153M		nsp	MECHA MAIN CHASSIS [F612-180]	456T105050
154M		420T352050	R-REEL BASE [F623-038]	420T352050
155M		420T352050	L-REEL BASE [F623-038]	420T352050
157M		59163202G0	WASHER [FJ111-17]	59163202G0
158M		59020802G0	WASHER [UJ12V-11]	59020802G0
161M		nsp	HEAD BASE [FC52E-37]	456T160050
162M		nsp	SPRING [FK26N-14]	420T115070
165M		nsp	HEAD SIFTER [FC52F-16]	456T110050
166M		456T054050	CAM GEAR [FD45B-16]	456T054050
167M		420T002050	PLAY ARM [FD45G-21]	420T002050
168M		420T115060	SPRING [FK28R-12]	420T115060
169M		425T273100	FLY-WHEEL ASSY (R) [FR22D-11]	425T273100
170M		425T273110	FLY-WHEEL ASSY (L) [FR22E-13]	425T273110
171M		59264702G0	WASHER [FJ111-30]	59264702G0
172M		59264705G0	WASHER [FJ111-14]	59264705G0
173M		64001500L0	E-RING [UG13U-15]	64001500L0
175M		456T264050	MAIN BELT [FF17G-31]	456T264050
176M		nsp	SPRING [FC52H-13]	420T116050
177M		420T354070	METAL SEARCH LEVER [FD44V-12]	420T354070
178M		420T354060	PACK SEARCH LEVER [FD44Y-12]	420T354060
179M		424T354100	REC SEARCH LEVER [FD44T-14]	424T354100
180M		nsp	REFLECTOR [UT11R-11]	420T274050
181M		456T358550	PINCH ROLLER (R) [FR20L-22]	456T358550
182M		456T358560	PINCH ROLLER (L) [FR20M-41]	456T358560
185M		nsp	ANTI EJECT ARM [FC39L-70]	424T002100
186M		nsp	SCREW [UG15S-11A]	424T010100
187M		nsp	SPRING FOR 185M [FK28R-15]	424T115100
188M		nsp	HEAD PCB HOLDER [FD45H-15]	420T271050
H071		*LH500030R	HEAD ASSY HADKH5559C	*LH500030R
L071		ME1035011R	SOLENOID ASSY [765-263]	ME1035011R
M071		MM1120904R	MAIN MOTOR ASSY F525-256	MM1120904R
M072		MM0075002R	REEL MOTOR ASSY [564-288]	MM0075002R
P071		nsp	CASSETTE SENSOR PCB [F567-404]	nsp
P072		nsp	PHOTO REFLECTOR PCB (TAKE UP)	nsp
P073		nsp	PHOTO REFLECTOR PCB (SUPPLY)	nsp
P074		nsp	MECHA CONNECT PCB (HEAD WIRE)	nsp
Q071		HW1000100R	PHOTO REFLE TAKE UP [AW13G-00]	HW1000100R
Q072		HW1000100R	PHOTO REFLE SUPPLY [AW13G-00]	HW1000100R
Q076		HW1000200R	QUICK SENSOR ASSY [AZ13P-00]	HW1000200R
S073		*SP000130R	SWITCH [UE16E-11]	*SP000130R
S076		*SP000130R	CRO2 SW [UE16E-11]	*SP000130R
S077				

NOTE : "nsp" PART IS LISTED FOR REFERENCE ONLY, MARANTZ WILL NOT SUPPLY THESE PARTS.



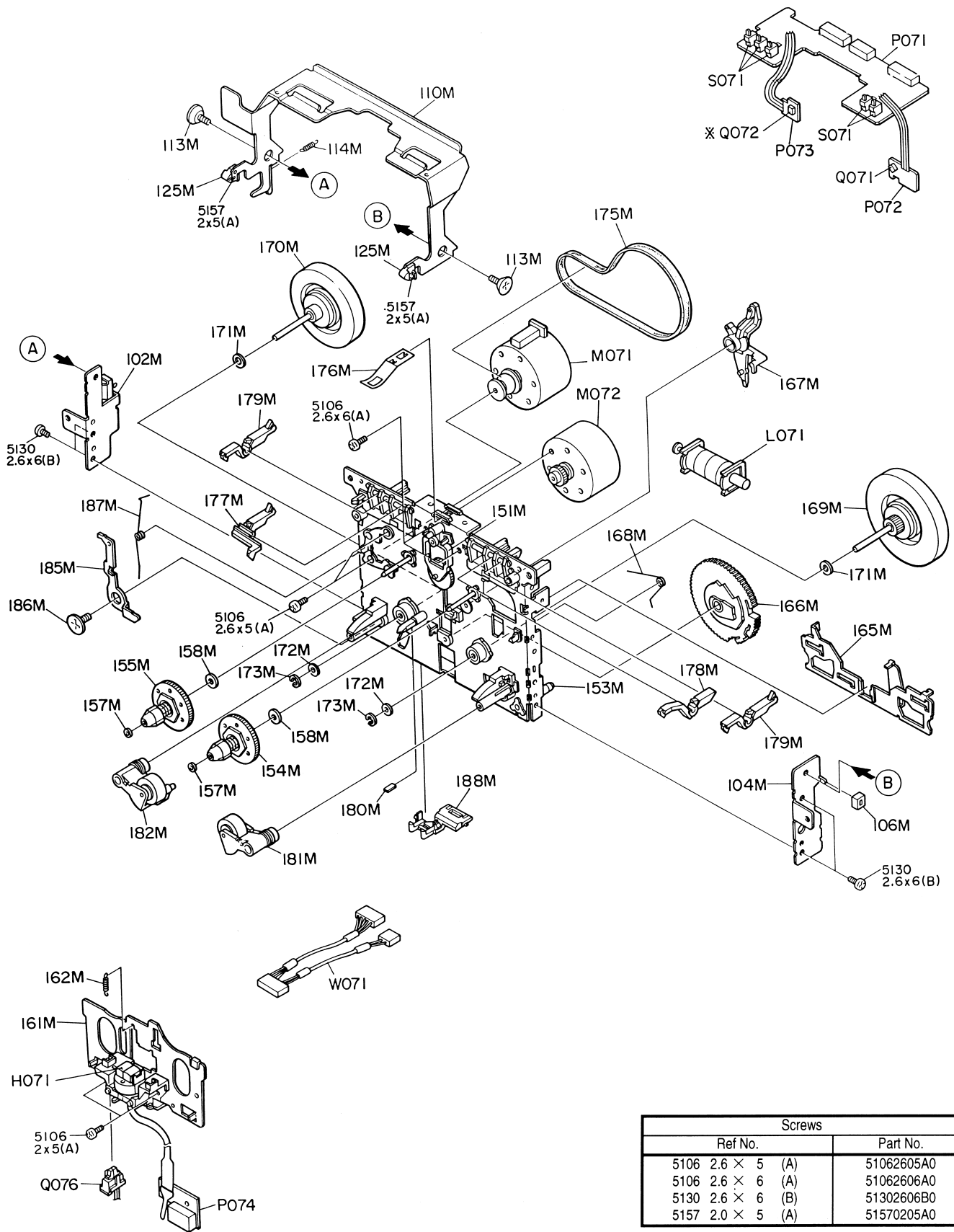

Screws		
Ref No.		Part No.
5106	2.6 × 5 (A)	51062605A0
5106	2.6 × 6 (A)	51062606A0
5130	2.6 × 6 (B)	51302606B0
5157	2.0 × 5 (A)	51570205A0

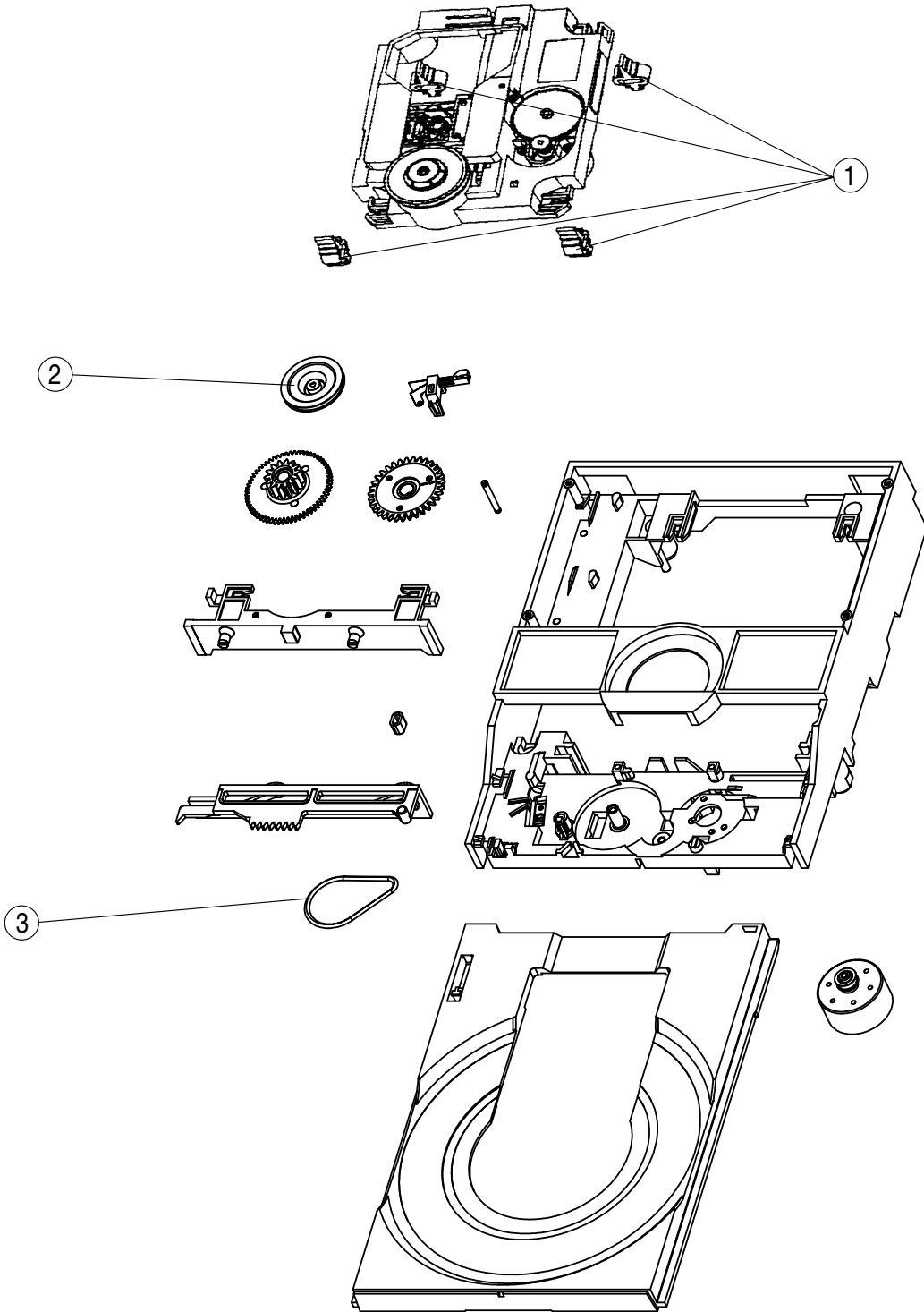

POS. NO	VERS. COLOR	PART NO. (FOR EUR)	DESCRIPTION	PART NO. (MJI)
1		QP40410986	SUSPENSION(4822 404 10986)	QP40410986
2		QP40111709	CLAMPER(4822 401 11709)	QP40111709
3		QP35810266	BELT(4822 358 10266)	QP35810266

NOTE : "nsp" PART IS LISTED FOR REFERENCE ONLY, MARANTZ WILL NOT SUPPLY THESE PARTS.

# 14. ELECTRICAL PARTS LIST

## ASSIGNMENT OF COMMON PARTS CODES.

### RESISTORS

R\*\*\*: 1) GD05xxx140, Carbon film fixed resistor, ±5% 1/4W  
 R\*\*\*: 2) GD05xxx160, Carbon film fixed resistor, ±5% 1/6W

① — Resistance value

Examples ;

① Resistance value  
 0.1 Ω .... 001    10 Ω .... 100    1 kΩ .... 102    100 kΩ .... 104  
 0.5 Ω .... 005    18 Ω .... 180    2.7 kΩ .... 272    680 kΩ .... 684  
 1 Ω .... 010    100 Ω .... 101    10 kΩ .... 103    1 MΩ .... 105  
 6.8 Ω .... 068    390 Ω .... 391    22 kΩ .... 223    4.7 MΩ .... 475

Note : Please distinguish 1/4W from 1/6W by the shape of parts used actually.

### CAPACITORS

C\*\*\*: CERAMIC CAP.

3) DD1xxx370, Ceramic capacitor  
 Disc type  
 Temp.coeff.P350 ~N1000, 50V  
 ② — Capacity value  
 ③ — Tolerance

Examples ;

② Tolerance (Capacity deviation)  
 ±0.25 pF .... 0  
 ±0.5 pF .... 1  
 ±5% .... 5

\* Tolerance of COMMON PARTS handled here are as follows :

0.5 pF ~ 5 pF .... ±0.25 pF  
 6 pF ~ 10 pF .... ±0.5 pF  
 12 pF ~ 560 pF .... ±5%

③ Capacity value



0.5 pF .... 005    3 pF .... 030    100 pF .... 101  
 1 pF .... 010    10 pF .... 100    220 pF .... 221  
 1.5 pF .... 015    47 pF .... 470    560 pF .... 561

C\*\*\*: CERAMIC CAP.

4) DK16xxx300, High dielectric constant ceramic capacitor  
 Disc type  
 Temp.chara. 2B4, 50V  
 ④ — Capacity value

Examples ;

④ Capacity value  
 100 pF .... 101    1000 pF .... 102    10000 pF .... 103  
 470 pF .... 471    2200 pF .... 222

C\*\*\*: 5) ELECTROLY CAP. (  ), 6) FILM CAP. (  )

5) EAxxx10, Electrolytic capacitor  
 One-way lead type, Tolerance ±20%  
 ⑤ — Capacity value  
 ⑥ — Working voltage

Examples ;

⑤ Capacity value  
 0.1 μF .... 104    4.7 μF .... 475    100 μF .... 107  
 0.33 μF .... 334    10 μF .... 106    330 μF .... 337  
 1 μF .... 105    22 μF .... 226    1100 μF .... 118  
 2200 μF .... 228

⑥ Working voltage

6.3V .... 006    25V .... 025  
 10V .... 010    35V .... 035  
 16V .... 016    50V .... 050

6) DF15xxx350 — Plastic film capacitor  
 DF15xxx310 — One-way type, Mylar ±5% 50V  
 DF16xxx310 — Plastic film capacitor  
 One-way type, Mylar ±10% 50V  
 ⑦ — Capacity value

Examples ;

⑦ Capacity value  
 0.001 μF (1000 pF) ..... 102    0.1 μF .... 104  
 0.0018 μF ..... 182    0.56 μF .... 564  
 0.01 μF ..... 103    1 μF .... 105  
 0.015 μF ..... 153

NOTE : 1) The above CODES ( R\*\*\*, R\*\*\*, C\*\*\*, C\*\*\* and C\*\*\* ) are omitted on the schematic diagram in some case.

2) On the occasion, be confirmed the common parts on the parts list.

3) Refer to "Common Parts List" for the other common parts (R105, DD4, DK4).

## NOTE ON SAFETY FOR FUSIBLE RESISTOR :

The suppliers and their type numbers of fusible resistors are as follows;

1. KOA Corporation

Part No. (MJI)	Type No. (KOA)	Description
NH05xxx140	RF25SxxxΩJ	(±5% 1/4W)
NH05xxx120	RF50SxxxΩJ	(±5% 1/2W)
NH85xxx110	RF73B2AxxxΩJ	(±5% 1/10W)
NH95xxx140	RF73B2ExxxΩJ	(±5% 1/4W)

\* Resistance value    Resistance value (0.1 Ω – 10 kΩ)

2. Matsushita Electronic Components Co., Ltd

Part No. (MJI)	Type No. (MEC)	Description
NF05xxx140	ERD-2FCJxxx	(±5% 1/4W)
RF05xxx140		
NF02xxx140	ERD-2FCGxxx	(±2% 1/4W)
RF02xxx140		

\* Resistance value    \* Resistance value

Examples ;

\* Resistance value  
 0.1 Ω .... 001    10 Ω .... 100    1 kΩ .... 102    100 kΩ .... 104  
 0.5 Ω .... 005    18 Ω .... 180    2.7 kΩ .... 272    680 kΩ .... 684  
 1 Ω .... 010    100 Ω .... 101    10 kΩ .... 103    1 MΩ .... 105  
 6.8 Ω .... 068    390 Ω .... 391    22 kΩ .... 223    4.7 MΩ .... 475



## ABBREVIATION AND MARKS

ANT. : ANTENNA	BATT. : BATTERY
CAP. : CAPACITOR	CER. : CERAMIC
CONN. : CONNECTING	DIG. : DIGITAL
HP : HEADPHONE	MIC. : MICROPHONE
μ-PRO : MICROPROCESSOR	REC. : RECORDING
RES. : RESISTOR	SPK : SPEAKER
SW : SWITCH	TRANSF. : TRANSFORMER
TRIM. : TRIMMING	TRS. : TRANSISTOR
VAR. : VARIABLE	X'TAL : CRYSTAL

## NOTE ON FUSE :

Regarding to all parts of parts code **FS20xxx2xx**, replace only with Wickmann-Werke GmbH, Type 372 non glass type fuse.

## NOTE ON SAFETY :

Symbol  Fire or electrical shock hazard. Only original parts should be used to replaced any part marked with symbol . Any other component substitution (other than original type), may increase risk of fire or electrical shock hazard.

## 安全上の注意 :

 がついている部品は、安全上重要な部品です。必ず指定されている部品番号の部品を使用して下さい。

POS. NO	VERS. COLOR	PART NO. (FOR EUR)	DESCRIPTION	PART NO. (MJI)	POS. NO	VERS. COLOR	PART NO. (FOR EUR)	DESCRIPTION	PART NO. (MJI)
RG51		RM02030360	<b>PG03-REC. VOL. CIRCUIT BOARD</b>	RM02030360	DC01				
RG52		RK01040660	VAR. RES. 20K-A	RK01040660	DC04		nsp	DIODE	HD20002000
RG53		nsp	VAR. RES. 100KB RK09K113 C,C BALANCE		DM01		nsp	1SS176 MA165 1SS254 30V 0.1A	
RG54		nsp	RES. 1k ±5% 1/6W	GD05102160	DM02		HD30621000	DIODE RL103E RECTRON	HD20003000
		nsp	RES. 1k ±5% 1/6W	GD05102160	DM03		HD30471000	DSF10C	HD30621000
					DU01		nsp	ZENER DIODE 6.2V	HD30471000
					DU02		nsp	ZENER DIODE NTJ4.7B 4.7V	HD20002000
					DU09		nsp	DIODE	HD20002000
							nsp	1SS176 MA165 1SS254 30V 0.1A	
							nsp	DIODE	HD20002000
							nsp	1SS176 MA165 1SS254 30V 0.1A	
							nsp	DIODE	HD20002000
							nsp	1SS176 MA165 1SS254 30V 0.1A	
C617		nsp	<b>PJ03-MAIN CIRCUIT BOARD</b>	EJ10405010					
C618		nsp	<b>PJ03-CAPACITORS</b>	EJ10405010					
C619		nsp	ELECT. 0.1µF 50V	EJ10405010					
C620		nsp	ELECT. 0.1µF 50V	EJ10405010	Q601		HC10101010	IC HA12155NT DOLBY B/C REC	HC10101010
C630		EA10701620	ELECT. 100µF 16V	EA10701620	Q603		BA20001000	AMP	BA20001000
C804		nsp	ELECT. 100µF M 16V RA-2	OA10701620	Q604		BA20001000	DIG.TRS.	BA20001000
C807		nsp	ELECT. 4700µF 25V	OA47802520				DTC114ES UN4211 10K 10K	
C809		EA47701020	ELECT. 470µF 10V	EA47701020				DIG.TRS.	BA20001000
C814		EA10802520	ELECT. 1000µF 25V	EA10802520				DTC114ES UN4211 10K 10K	
C852		EA47601620	ELECT. 47µF 16V	EA47601620	Q801		HC3891509F	AVR NJM7815FA 15V 1A	HC3891509F
C871		EA10605020	ELECT. 10µF 50V	EA10605020	Q802		HC3890509F	AVR NJM7805FA 5V 1A	HC3890509F
C913		EA47601620	ELECT. 47µF 16V	EA47601620	Q803		BA20001000	DIG.TRS.	BA20001000
C915		nsp	ELECT. 100µF M 16V RA-2	OA10701620				DTC114ES UN4211 10K 10K	
CC05		EA47601620	ELECT. 47µF 16V	EA47601620	Q804		HC3890809F	AVR NJM7808FA 8V 1A	HC3890809F
CE05		nsp	ELECT. 100µF M 16V RA-2	OA10701620	Q805		BA10002000	DIG.TRS.	BA10002000
CE43		EA47601620	ELECT. 47µF 16V	EA47601620				DTA144ES UN4113 47K 47K	
CG05		EA47601620	ELECT. 47µF 16V	EA47601620	Q806		BA20001000	DIG.TRS.	BA20001000
CG06		EA47601620	ELECT. 47µF 16V	EA47601620				DTC114ES UN4211 10K 10K	
CJ13		nsp	ELECT. 100µF M 16V RA-2	OA10701620	Q807		BA20002000	DIG.TRS.	BA20002000
CK01		nsp	ELECT. 0.47µF 50V	EJ47405010				DTC144ES UN4213 47K 47K	
CK02		nsp	ELECT. 0.47µF 50V	EJ47405010	Q808		HC3890509F	AVR NJM7805FA 5V 1A	HC3890509F
					Q851		HT213572B0	TRS. 2SB1357 E OR F 50V 1.8W	HT213572B0
					Q871		HT421442A0	TRS. 2SD2144S U OR V	HT421442A0
					Q872		BA20002000	DIG.TRS. DTC144ES UN4213 47K 47K	BA20002000
R633		NF02100140	<b>PJ03-RESISTORS</b>	NF02100140	Q873		BA10032210	DIG.TRS. DTA125TS	BA10032210
R810		NF05047140	FUSE 10 G 1/4W	NF05047140	Q901		HC10200060	IC UPC1297CA HX-PRO	HC10200060
R811		NF05047140	FUSE 4.7 J 1/4W	NF05047140	Q902		BA20001000	DIG.TRS.	BA20001000
R858		NF02330140	FUSE 4.7 J 1/4W	NF02330140				DTC114ES UN4211 10K 10K	
R907		RA01030780	FUSE 33 G 1/4W	RA01030780	Q903		BA20001000	DIG.TRS.	BA20001000
R908		RA01030780	TRIM. 10k RH0638C14R	RA01030780				DTC114ES UN4211 10K 10K	
RJ15		RA01030780	TRIM. 10k RH0638C14R	RA01030780				DIG.TRS.	BA20001000
RJ16		RA01030780	TRIM. 10k RH0638C14R	RA01030780				DTC114ES UN4211 10K 10K	
RK05		RA01030780	TRIM. 10k RH0638C14R	RA01030780					
RK06		RA01030780	TRIM. 10k RH0638C14R	RA01030780	QC01		HC10008090	IC NJM4558D-D	HC10008090
RK13		nsp	24k ±5% 1/6W	GD05243160	QC02		BA20001000	DIG.TRS.	BA20001000
RM33		NH05100140	FUSIBLE 10 J 1/4W	NH05100140				DTC114ES UN4211 10K 10K	
RM36		RA01030780	TRIM. 10k RH0638C14R	RA01030780	QC03		HT30001000	TRS. 2SC536SP 2SC2458 2SC3311 2SC1740S	HT30001000
					QC04		HT30001000	TRS. 2SC536SP 2SC2458 2SC3311 2SC1740S	HT30001000
D801		HE20020290	<b>PJ03-SEMICONDUCTORS</b>	HE20020290	QE01		BA20028210	DIG.TRS. DTC323TS 2.2K	BA20028210
D806		nsp	DIODE D3SB20 V=200V IO=3.0A	HD20002000	QE02		BA20028210	DIG.TRS. DTC323TS 2.2K	BA20028210
			DIODE		QE03		HC10008090	IC NJM4558D-D	HC10008090
D807		nsp	1SS176 MA165 1SS254 30V 0.1A	HD20003000	QE04		HT30001000	TRS. 2SC536SP 2SC2458 2SC3311 2SC1740S	HT30001000
			DIODE RL103E RECTRON					DIG.TRS. DTC323TS 2.2K	BA20028210
D809		nsp	DSF10C	HD20002000				DIG.TRS. DTC323TS 2.2K	BA20028210
			DIODE					IC NJM4558D-D	HC10008090
D812		nsp	1SS176 MA165 1SS254 30V 0.1A	HD20002000	QE21		BA20028210	DIG.TRS. DTC323TS 2.2K	BA20028210
			DIODE 1SS176 MA165 1SS254 30V 0.1A		QE22		BA20028210	DIG.TRS. DTC323TS 2.2K	BA20028210
D813		nsp	DIODE	HD20002000	QE23		HC10008090	IC NJM4558D-D	HC10008090
			1SS176 MA165 1SS254 30V 0.1A		QE41		HC10008090	IC NJM4558D-D	HC10008090
D851		HD20003000	DIODE RL103E RECTRON	HD20003000	QE43		BA20028210	DIG.TRS. DTC323TS 2.2K	BA20028210
			DSF10C		QE44		BA20028210	DIG.TRS. DTC323TS 2.2K	BA20028210
D852		HD30621000	ZENER DIODE 6.2V	HD30621000	QG01		HC10053090	IC NJM-2068-DD	HC10053090
D853		HD31301000	ZENER DIODE 13V	HD31301000	QG02		HC10053090	IC NJM-2068-DD	HC10053090
D854		HD31301000	ZENER DIODE 13V	HD31301000	QG03		HC406621B0	IC BU4066B C-MOS	HC406621B0
D855		HD20003000	DIODE RL103E RECTRON	HD20003000	QG05		BA20002000	DIG.TRS.	BA20002000
			DSF10C					DTC144ES UN4213 47K 47K	
D871		nsp	DIODE	HD20002000	QG06		BA20002000	DIG.TRS.	BA20002000
			1SS176 MA165 1SS254 30V 0.1A		QJ01		HC10206060	DTC144ES UN4213 47K 47K	HC10206060
D874								IC UPC1330HA HEAD SWITCH	HC10206060

NOTE : "nsp" PART IS LISTED FOR REFERENCE ONLY, MARANTZ WILL NOT SUPPLY THESE PARTS.

POS. NO	VERS. COLOR	PART NO. (FOR EUR)	DESCRIPTION	PART NO. (MJI)	POS. NO	VERS. COLOR	PART NO. (FOR EUR)	DESCRIPTION	PART NO. (MJI)
QJ02		HC10053090	IC NJM-2068-DD	HC10053090				<b>PP01-RS232C</b>	
QJ03		BA20002000	DIG.TRS.	BA20002000				<b>CIRCUIT BOARD</b>	
			DTC144ES UN4213 47K 47K					<b>PP01-CAPACITORS</b>	
QJ04		BA20002000	DIG.TRS.	BA20002000	CR04		nsp	CER. CHIP 0.1µF GRM39F104Z16	DK98104200
			DTC144ES UN4213 47K 47K		CR08				
QK01		BA20028210	DIG.TRS. DTC323TS 2.2K	BA20028210	CR10		nsp	CER. CHIP 220pF	DK96221300
QK02		BA20028210	DIG.TRS. DTC323TS 2.2K	BA20028210	CR11		nsp	CER. CHIP 220pF	DK96221300
QL01		HT418622A0	TRS. 2SD1862 TV-2 NPN Q R	HT418622A0	CR36		nsp	CER. CHIP 22pF ±5% CG 50V	DD95220300
QL02		HT412922A0	TRS. 2SD1292 Q OR R	HT412922A0	CR37		nsp	CER. CHIP 22pF ±5% CG 50V	DD95220300
QL03		BA20001000	DIG.TRS.	BA20001000				<b>PP01-RESISTORS</b>	
			DTC114ES UN4211 10K 10K		RR35		nsp	CHIP 0Ω ±5% 1/16W	NN05000610
QL04		HT30001000	TRS. 2SC536SP 2SC2458 2SC3311	HT30001000	RR36		nsp	CHIP 0Ω ±5% 1/16W	NN05000610
			2SC1740S		RR37		nsp	CHIP 100Ω ±5% 1/16W	NN05101610
QM02		HT421442A0	TRS. 2SD2144S U OR V	HT421442A0	RR38		nsp	CHIP 100Ω ±5% 1/16W	NN05101610
QM03		HC10279030	IC LB1641 MOTOR DRIVER	HC10279030				<b>PP01-SEMICONDUCTOR</b>	
QM04		BA20002000	DIG.TRS.	BA20002000	QR01	HC10204990		IC HIN202ECB 16LEAD WIDE BODY	HC10204990
			DTC144ES UN4213 47K 47K					<b>PP01-MISCELLANEOU</b>	
QM05		BA20001000	DIG.TRS.	BA20001000	JR01	YT02090160		TERMINAL D-SUB 9PIN F	YT02090160
QM07			DTC114ES UN4211 10K 10K					<b>PS01-CD MAIN</b>	
QM12		BA10032210	DIG.TRS. DIGI-TRA DTA125TS	BA10032210				<b>CIRCUIT BOARD</b>	
QM13		BA10032210	DIG.TRS. DTA125TS	BA10032210				<b>PS01-CAPACITORS</b>	
QM14									
QM16		BA20002000	DIG.TRS.	BA20002000					
QM31		HT421442A0	TRS. 2SD2144S U OR V	HT421442A0	C101		nsp	CER. CHIP 5pF ±0.25pF CH 50V	DD90050300
QU02		HT30001000	TRS. 2SC536SP 2SC2458 2SC3311	HT30001000	C102		nsp	CER. CHIP 0.01µF	DK98103300
			2SC1740S		C103		nsp	CER. CHIP 0.1µF GRM39F104Z16	DK98104200
QU03		BA10002000	DIG.TRS.	BA10002000	C104		nsp	CER. CHIP 4700pF ±10 % B 50V	DK96472300
			DTA144ES UN4113 47K 47K		C105				
QU04		HT30001000	TRS. 2SC536SP 2SC2458 2SC3311	HT30001000	}	EY47601020		TANTL. CHIP 47µF 10V	EY47601020
			2SC1740S		C109				
QU05		BA10002000	DIG.TRS.	BA10002000	C110	EY10700620		TANTL. CHIP 100µF 6.3V	EY10700620
			DTA144ES UN4113 47K 47K		C111				
QU06		HC709449B0	IC 74HC4094 16PIN DIP PHILIPS	HC709449B0	}		nsp	CER. CHIP 0.1µF GRM39F104Z16	DK98104200
QU08		BA10001000	DIG.TRS.	BA10001000	C114				
			DTA114ES UN4111 10K 10K		C115		nsp	CER. CHIP 1000pF ±10 % B 50V	DK96102300
QU09		BA10001000	DIG.TRS.	BA10001000	C116		nsp	CER. CHIP 1000pF ±10 % B 50V	DK96102300
			DTA114ES UN4111 10K 10K		C117				
			<b>PJ03-MISCELLANEOUS</b>		}		nsp	CER. CHIP 0.1µF GRM39F104Z16	DK98104200
JG01		YT02080140	TERMINAL CINCH PIN JACK 2L8P	YT02080140	C120				
			LEFT SIDE SHIELD		C121		nsp	CER. CHIP 1000pF ±10 % B 50V	DK96102300
JG03		YJ01004780	PHONE JACK YKB21-5209 GOLD	YJ01004780	C122				
JG04		YJ01004780	PHONE JACK YKB21-5209 GOLD	YJ01004780	}		nsp	CER. CHIP 0.1µF GRM39F104Z16	DK98104200
JT02		YT02010780	TERMINAL CINCH PIN	YT02010780	C125				
			14X14 RA 1L1P BLK NI FLM-GND		C126		nsp	CER. CHIP 1000pF ±10 % B 50V	DK96102300
JU04		YJ01003050	JACK HLJ0521-01-1010	YJ01003050	C127		nsp	CER. CHIP 0.1µF GRM39F104Z16	DK98104200
			TAPE FADER		C128		nsp	CER. CHIP 0.1µF GRM39F104Z16	DK98104200
JU05		YJ01003050	JACK HLJ0521-01-1010 CD FADER	YJ01003050	C129		nsp	CER. CHIP 1000pF ±10 % B 50V	DK96102300
JU31		YT02020890	TERMINAL 2P CINCH PIN JACK	YT02020890	C130		nsp	CER. CHIP 0.1µF GRM39F104Z16	DK98104200
			FOR RC-5		C131		nsp	CER. CHIP 1000pF ±10 % B 50V	DK96102300
JU32		YT02020970	TERMINAL CINCH PIN YKC21-3249	YT02020970	C132		nsp	CER. CHIP 0.1µF GRM39F104Z16	DK98104200
			FOR EXT. I/O		C133		nsp	CER. CHIP 0.1µF GRM39F104Z16	DK98104200
L601		LS10415020	M.P.X. COIL	LS10415020					
L602		LS10415020	M.P.X. COIL	LS10415020	C301		nsp	CER. CHIP 0.047µF	DK98473300
L901		TC10110030	OSC TRANSF.	TC10110030	C302		nsp	CER. CHIP 1000pF ±10 % B 50V	DK96102300
			HX-PRO COIL 105kHz		C303		nsp	CER. CHIP 0.01µF	DK98103300
L902		TC10110030	OSC TRANSF.	TC10110030	C304		nsp	CER. CHIP 1µF 10V F	DK98105200
			HX-PRO COIL 105kHz		C305		nsp	CER. CHIP 47pF ±5 % CG 50V	DD95470300
LK01		LC22260710	CHOKO COIL TL-8 223J	LC22260710	C306		nsp	CER. CHIP 0.022µF	DK98223300
LK02		LC22260710	CHOKO COIL TL-8 223J	LC22260710	C307	EY47601020		TANTL. CHIP 47µF 10V	EY47601020
LL01		TC10140350	OSC TRANSF.	TC10140350	C308	EY10601620		TANTL. CHIP 10µF 16V	EY10601620
			BIAS OSC COIL 105KHZ OF-10		C309		nsp	CER. CHIP 22pF ±5 % CG 50V	DD95220300
LL02		LC11010130	CHOKO COIL EL0607RA101K	LC11010130	C310		nsp	CER. CHIP 82pF	DD95820300
LT01		TP41042010	PULSE TRANSF. FOR CD	TP41042010	C311	EY47601020		TANTL. CHIP 47µF 10V	EY47601020
S601		SS02020970	SLIDE SWITCH MPX FILTER	SS02020970	C312	EY10601620		TANTL. CHIP 10µF 16V	EY10601620
			SSSUI-6MM KNOB		C313	EY47601020		TANTL. CHIP 47µF 10V	EY47601020
					C314		nsp	CER. CHIP 180pF	DD95181300

NOTE : \*nsp\* PART IS LISTED FOR REFERENCE ONLY, MARANTZ WILL NOT SUPPLY THESE PARTS.

POS. NO	VERS. COLOR	PART NO. (FOR EUR)	DESCRIPTION	PART NO. (MJJ)	POS. NO	VERS. COLOR	PART NO. (FOR EUR)	DESCRIPTION	PART NO. (MJJ)
C315		nsp	CER. CHIP 220pF	DK96221300	CU51		nsp	CER. CHIP 0.1μF GRM39F104Z16	DK98104200
C316		nsp	CER. CHIP 220pF	DK96221300	CU52		nsp	CER. CHIP 0.1μF GRM39F104Z16	DK98104200
C317		nsp	CER. CHIP 330pF	DK96331300	CU53		nsp	CER. CHIP 0.1μF GRM39F104Z16	DK98104200
C318		nsp	CER. CHIP 180pF	DD95181300	CU54		nsp	CER. CHIP 1μF 10V F	DK98105200
C319		nsp	CER. CHIP 220pF	DK96221300	CU55		nsp	CER. CHIP 0.1μF GRM39F104Z16	DK98104200
C320		nsp	CER. CHIP 220pF	DK96221300					
C321		nsp	CER. CHIP 180pF	DD95181300					
C322		nsp	CER. CHIP 220pF	DK96221300					
C323		nsp	CER. CHIP 22pF ±5 % CG 50V	DD95220300	R101		nsp	<b>PS01-RESISTORS</b> CHIP 4.7kΩ ±5% 1/16W	NN05472610
C324		nsp	CER. CHIP 180pF	DD95181300	R102		nsp	CHIP 4.7kΩ ±5% 1/16W	NN05472610
C325		nsp	CER. CHIP 220pF	DK96221300	R103		nsp	CHIP 4.7kΩ ±5% 1/16W	NN05472610
C326		nsp	CER. CHIP 1μF 10V F	DK98105200	R104		nsp	CHIP 220kΩ ±5% 1/16W	NN05224610
C327		nsp	CER. CHIP 22pF ±5 % CG 50V	DD95220300	R105		nsp	CHIP 2.2kΩ ±5% 1/16W	NN05222610
C328		nsp	CER. CHIP 22pF ±5 % CG 50V	DD95220300	R106		nsp	CHIP 100kΩ ±5% 1/16W	NN05104610
C329		nsp	CER. CHIP 0.01μF	DK98103300	R107		nsp	CHIP 15kΩ ±5% 1/16W	NN05153610
					R109		nsp	CHIP 10kΩ ±5% 1/16W	NN05103610
C330		nsp	CER. CHIP 0.1μF GRM39F104Z16	DK98104200	R110		nsp	CHIP 47Ω ±5% 1/16W	NN05470610
C331		nsp	CER. CHIP 0.01μF	DK98103300	R111		nsp	CHIP 5.6kΩ ±5% 1/16W	NN05562610
C332		nsp	CER. CHIP 0.01μF	DK98103300	R113		nsp	CHIP 2.7kΩ ±5% 1/16W	NN05272610
C334		nsp	CER. CHIP 22pF ±5 % CG 50V	DD95220300	R114		nsp	CHIP 5.6kΩ ±5% 1/16W	NN05562610
C335		nsp	CER. CHIP 0.1μF GRM39F104Z16	DK98104200	R115		nsp	CHIP 12kΩ ±5% 1/16W	NN05123610
C337		nsp	CER. CHIP 0.1μF GRM39F104Z16	DK98104200	R116		nsp	CHIP 1kΩ ±5% 1/16W	NN05102610
C338		nsp	CER. CHIP 2200pF	DK96222300	R117		nsp	CHIP 1.5kΩ ±5% 1/16W	NN05152610
C340		nsp	CER. CHIP 0.1μF GRM39F104Z16	DK98104200	R118		nsp	CHIP 18kΩ ±5% 1/16W	NN05183610
C341		nsp	CER. CHIP 1μF 10V F	DK98105200	R119		nsp	CHIP 15kΩ ±5% 1/16W	NN05153610
C342		nsp	CER. CHIP 0.1μF GRM39F104Z16	DK98104200	R120		nsp	CHIP 12kΩ ±5% 1/16W	NN05123610
C343		nsp	CER. CHIP 0.1μF GRM39F104Z16	DK98104200	R121		nsp	CHIP 10kΩ ±5% 1/16W	NN05103610
C344		nsp	CER. CHIP 0.1μF GRM39F104Z16	DK98104200	R122		nsp	CHIP 12kΩ ±5% 1/16W	NN05123610
C345		nsp	CER. CHIP 0.1μF GRM39F104Z16	DK98104200	R123		nsp	CHIP 12kΩ ±5% 1/16W	NN05123610
C346	EY47601020	TANTL. CHIP	47μF 10V	EY47601020	R124		nsp	CHIP 1kΩ ±5% 1/16W	NN05102610
C350		nsp	CER. CHIP C1608X7R1H104K	DK96104300	R125		nsp	CHIP 390Ω ±5% 1/16W	NN05391610
C351	EY10700620	TANTL. CHIP	100μF 6.3V	EY10700620	R126		nsp	CHIP 22Ω ±5% 1/16W	NN05220610
C352		nsp	CER. CHIP 0.1μF GRM39F104Z16	DK98104200	R127		nsp	CHIP 15kΩ ±5% 1/16W	NN05153610
C353		nsp	CER. CHIP 0.1μF GRM39F104Z16	DK98104200	R129		nsp	CHIP 1kΩ ±5% 1/16W	NN05102610
C354		nsp	CER. CHIP 0.1μF GRM39F104Z16	DK98104200	R130		nsp	CHIP 22Ω ±5% 1/16W	NN05220610
C355		nsp	CER. CHIP 0.1μF GRM39F104Z16	DK98104200	R131		nsp	CHIP 220Ω ±5% 1/16W	NN05221610
C356		nsp	CER. CHIP 1μF 10V F	DK98105200	R132		nsp	CHIP 220Ω ±5% 1/16W	NN05221610
C357		nsp	CER. CHIP 0.1μF GRM39F104Z16	DK98104200	R133		nsp	CHIP 22Ω ±5% 1/16W	NN05220610
C358		nsp	CER. CHIP 1μF 10V F	DK98105200	R134		nsp	CHIP 22Ω ±5% 1/16W	NN05220610
C359		nsp	CER. CHIP 0.1μF GRM39F104Z16	DK98104200	R135		nsp	CHIP 3.3kΩ ±5% 1/16W	NN05332610
					R136		nsp	CHIP 180kΩ ±5% 1/16W	NN05184610
C360		nsp	CER. CHIP 1μF 10V F	DK98105200	R137		nsp	CHIP 100kΩ ±5% 1/16W	NN05104610
C361		nsp	CER. CHIP 4700pF ±10 % B 50V	DK96472300	R138		nsp	CHIP 100kΩ ±5% 1/16W	NN05104610
C362		nsp	CER. CHIP 470pF	DK96471300	R139		nsp	CHIP 1kΩ ±5% 1/16W	NN05102610
C363		nsp	CER. CHIP 1μF 10V F	DK98105200					
C364		nsp	CER. CHIP 0.1μF GRM39F104Z16	DK98104200	R140		nsp	CHIP 10kΩ ±5% 1/16W	NN05103610
C365		nsp	CER. CHIP 470pF	DK96471300	R141		nsp	CHIP 470Ω ±5% 1/16W	NN05471610
C366		nsp	CER. CHIP 4700pF ±10 % B 50V	DK96472300	R142		nsp	CHIP 2.2kΩ ±5% 1/16W	NN05222610
C367		nsp	CER. CHIP 0.1μF GRM39F104Z16	DK98104200	R143		nsp	CHIP 100kΩ ±5% 1/16W	NN05104610
C368		nsp	CER. CHIP 0.1μF GRM39F104Z16	DK98104200	R144		nsp	CHIP 1kΩ ±5% 1/16W	NN05102610
C369	EY10700620	TANTL. CHIP	100μF 6.3V	EY10700620	R145		nsp	CHIP 100Ω ±5% 1/16W	NN05101610
C370		nsp	CER. CHIP 100pF ±5 % CG 50V	DD95101300	R146		nsp	CHIP 2.2kΩ ±5% 1/16W	NN05222610
C371		nsp	CER. CHIP 100pF ±5 % CG 50V	DD95101300	R147		nsp	CHIP 2.2kΩ ±5% 1/16W	NN05222610
C372		nsp	CER. CHIP 100pF ±5 % CG 50V	DD95101300	R148		nsp	CHIP 100kΩ ±5% 1/16W	NN05104610
C381		nsp	CER. CHIP 0.1μF GRM39F104Z16	DK98104200	R149		nsp	CHIP 150kΩ ±5% 1/16W	NN05154610
C382	EY10601620	TANTL. CHIP	10μF 16V	EY10601620	R150		nsp	CHIP 10kΩ ±5% 1/16W	NN05103610
C383	EY10601620	TANTL. CHIP	10μF 16V	EY10601620	R151		nsp	CHIP 0Ω ±5% 1/16W	NN05000610
C384	EY10601620	TANTL. CHIP	10μF 16V	EY10601620	R152		nsp	CHIP 0Ω ±5% 1/16W	NN05000610
C385		nsp	CER. CHIP 1000pF ±10 % B 50V	DK96102300	R211		nsp	CHIP 68Ω ±5% 1/16W	NN05680610
C386		nsp	CER. CHIP 1000pF ±10 % B 50V	DK96102300	R212		nsp	CHIP 5.6Ω ±5% 1/16W	NN05056610
C387		nsp	CER. CHIP 150pF ±5 % CG 50V	DD95151300	R213		nsp	CHIP 5.6Ω ±5% 1/16W	NN05056610
C388		nsp	CER. CHIP 150pF ±5 % CG 50V	DD95151300	R220		nsp	CHIP 12kΩ ±5% 1/16W	NN05123610
C389	EY10601620	TANTL. CHIP	10μF 16V	EY10601620					
C390	EY47601020	TANTL. CHIP	47μF 10V	EY47601020	R301		nsp	CHIP 470Ω ±5% 1/16W	NN05471610
C391		nsp	CER. CHIP 0.1μF GRM39F104Z16	DK98104200	R302		nsp	CHIP 1MΩ ±5% 1/16W	NN05105610
C392		nsp	CER. CHIP 0.1μF GRM39F104Z16	DK98104200	R303		nsp	CHIP 22kΩ ±5% 1/16W	NN05223610
C393	EY10700620	TANTL. CHIP	100μF 6.3V	EY10700620	R304				
C395		nsp	CER. CHIP 39pF ±5 % CG 50V	DD95390300	}		nsp	CHIP 10kΩ ±5% 1/16W	NN05103610
C396		nsp	CER. CHIP 27pF	DD95270300	R315				
C397		nsp	CER. CHIP C1608X7R1H104K	DK96104300	R316		nsp	CHIP 47Ω ±5% 1/16W	NN05470610

NOTE : "nsp" PART IS LISTED FOR REFERENCE ONLY, MARANTZ WILL NOT SUPPLY THESE PARTS.

POS. NO	VERS. COLOR	PART NO. (FOR EUR)	DESCRIPTION	PART NO. (MJI)	POS. NO	VERS. COLOR	PART NO. (FOR EUR)	DESCRIPTION	PART NO. (MJI)
R317		nsp	CHIP 33kΩ ±5% 1/16W	NN05333610	R393		nsp	CHIP 10kΩ ±5% 1/16W	NN05103610
R318		nsp	CHIP 22Ω ±5% 1/16W	NN05220610	R394		nsp	CHIP 10kΩ ±5% 1/16W	NN05103610
R319		nsp	CHIP 22Ω ±5% 1/16W	NN05220610	R395				
R320		nsp	CHIP 100Ω ±5% 1/16W	NN05101610	}		nsp	CHIP 100Ω ±5% 1/16W	NN05101610
R321		nsp	CHIP 10kΩ ±5% 1/16W	NN05103610	R398				
R322		nsp	CHIP 10Ω ±5% 1/16W	NN05100610	R399		FC90020110	CHIP FERRITE BLM11B601S	FC90020110
R323		nsp	CHIP 0Ω ±5% 1/16W	NN05000610					
R324		nsp	CHIP 1kΩ ±5% 1/16W	NN05102610	RU51		nsp	CHIP 47kΩ ±5% 1/16W	NN05473610
R325		nsp	CHIP 10kΩ ±5% 1/16W	NN05103610	RU52		nsp	CHIP 10Ω ±5% 1/16W	NN05100610
R326		nsp	CHIP 100Ω ±5% 1/16W	NN05101610	RU53		nsp	CHIP 47kΩ ±5% 1/16W	NN05473610
R327		nsp	CHIP 1kΩ ±5% 1/16W	NN05102610	RU54		nsp	CHIP 10Ω ±5% 1/16W	NN05100610
R328		nsp	CHIP 47Ω ±5% 1/16W	NN05470610	RU56		nsp	CHIP 10Ω ±5% 1/16W	NN05100610
R329		nsp	CHIP 100Ω ±5% 1/16W	NN05101610	RU58		nsp	CHIP 47kΩ ±5% 1/16W	NN05473610
					RU60		nsp	CHIP 47kΩ ±5% 1/16W	NN05473610
R330		FN31000020	CHIP FERRITE BLM11B252SD	FN31000020	RU61		nsp	CHIP 10Ω ±5% 1/16W	NN05100610
R331		nsp	CHIP 100Ω ±5% 1/16W	NN05101610	RU63		nsp	CHIP 4.7kΩ ±5% 1/16W	NN05472610
R332		nsp	CHIP 1kΩ ±5% 1/16W	NN05102610	RU69		nsp	CHIP 10kΩ ±5% 1/16W	NN05103610
R333		nsp	CHIP 680Ω ±5% 1/16W	NN05681610	RU70		nsp	CHIP 2.2kΩ ±5% 1/16W	NN05222610
R334		nsp	CHIP 1kΩ ±5% 1/16W	NN05102610	RU71		nsp	CHIP 10kΩ ±5% 1/16W	NN05103610
R335		nsp	CHIP 1MΩ ±5% 1/16W	NN05105610	RU72		nsp	CHIP 1kΩ ±5% 1/16W	NN05102610
R336		nsp	CHIP 220Ω ±5% 1/16W	NN05221610	RU73		nsp	CHIP 1kΩ ±5% 1/16W	NN05102610
R337		nsp	CHIP 10kΩ ±5% 1/16W	NN05103610	RU74		nsp	CHIP 1kΩ ±5% 1/16W	NN05102610
R338		nsp	CHIP 10kΩ ±5% 1/16W	NN05103610	RU75		nsp	CHIP 1kΩ ±5% 1/16W	NN05102610
R339		nsp	CHIP 10kΩ ±5% 1/16W	NN05103610	RU76		nsp	CHIP 22kΩ ±5% 1/16W	NN05223610
R340		nsp	CHIP 10kΩ ±5% 1/16W	NN05103610	RU77		nsp	CHIP 22kΩ ±5% 1/16W	NN05223610
R342		nsp	CHIP 10Ω ±5% 1/16W	NN05100610	RU78		nsp	CHIP 10kΩ ±5% 1/16W	NN05103610
R343		nsp	CHIP 5.6Ω ±5% 1/16W	NN05056610					
R344		nsp	CHIP 4.7kΩ ±5% 1/16W	NN05472610					
R345		nsp	CHIP 4.7kΩ ±5% 1/16W	NN05472610					
R346		nsp	CHIP 4.7kΩ ±5% 1/16W	NN05472610	D101		HZ21005000	CHIP DIODE 1SS301 DAN202U	HZ21005000
R347		nsp	CHIP 220Ω ±5% 1/16W	NN05221610	D102		HZ21005000	CHIP DIODE 1SS301 DAN202U	HZ21005000
R348		nsp	CHIP 100Ω ±5% 1/16W	NN05101610	D301		HZ30011020	CHIP DIODE MA8043M	HZ30011020
R349		nsp	CHIP 22Ω ±5% 1/16W	NN05220610	D302		HZ21005000	CHIP DIODE 1SS301 DAN202U	HZ21005000
R350		FN31000020	CHIP FERRITE BLM11B252SD	FN31000020	DU51		HZ21005000	CHIP DIODE 1SS301 DAN202U	HZ21005000
R351		nsp	CHIP 1kΩ ±5% 1/16W	NN05102610					
R352		nsp	CHIP 10Ω ±5% 1/16W	NN05100610	Q101		HC10207490	IC TZA1024 RF AMP	HC10207490
R353		nsp	CHIP 10Ω ±5% 1/16W	NN05100610	Q102		HX300012A0	CHIP TRS.	HX300012A0
R354		nsp	CHIP 4.7Ω ±5% 1/16W	NN05047610					
R355					Q103		HC10165490	IC TDA7073AT SOP DUAL BTL DRIVER	HC10165490
}		nsp	CHIP 10Ω ±5% 1/16W	NN05100610	Q104		HC10165490	IC TDA7073AT SOP DUAL BTL DRIVER	HC10165490
R359					Q105		HC10165490	IC TDA7073AT SOP DUAL BTL DRIVER	HC10165490
R360		nsp	CHIP 330Ω ±5% 1/16W	NN05331610					
R361		nsp	CHIP 330Ω ±5% 1/16W	NN05331610	Q106		BA10026210	DIG.TR.S. DTA114EU	BA10026210
R362		nsp	CHIP 330Ω ±5% 1/16W	NN05331610	Q107		BA20035210	DIG.TR.S. DTC114EU	BA20035210
R363		nsp	CHIP 10Ω ±5% 1/16W	NN05100610	Q108		BA20035210	DIG.TR.S. DTC114EU	BA20035210
R364		nsp	CHIP 10Ω ±5% 1/16W	NN05100610	Q109		HX300012A0	CHIP TRS.	HX300012A0
R365		nsp	CHIP 1kΩ ±5% 1/16W	NN05102610					
R366		nsp	CHIP 10Ω ±5% 1/16W	NN05100610	Q110		HX100012A0	2SC4081 Q R 2SC4116 Y GR CHIP TRS.	HX100012A0
R367		nsp	CHIP 470kΩ ±5% 1/16W	NN05474610					
R368		nsp	CHIP 470Ω ±5% 1/16W	NN05471610					
R369					Q111		HX300012A0	2SA1586 Y GR 2SA1576A Q R CHIP TRS.	HX300012A0
}		nsp	CHIP 1kΩ ±5% 1/16W	NN05102610	Q114			2SC4081 Q R 2SC4116 Y GR	
R373					Q301		HC10209490	IC SAA7324H M2B	HC10209490
R374		nsp	CHIP 10kΩ ±5% 1/16W	NN05103610	Q302		HC762837Z0	IC SN74LS628NS	HC762837Z0
R375		nsp	CHIP 10kΩ ±5% 1/16W	NN05103610	Q303		HC10225210	IC BU2630FV-E2	HC10225210
R377		nsp	CHIP 47kΩ ±5% 1/16W	NN05473610	Q351		HC10010540	IC STA016T MP3 DECODER	HC10010540
R378		nsp	CHIP 47kΩ ±5% 1/16W	NN05473610	Q352		HX346721A0	CHIP TRS. 2SC4672 Q	HX346721A0
R379		nsp	CHIP 0Ω ±5% 1/16W	NN05000610	Q353		HC700805S0	IC TC7S08F	HC700805S0
R380		FN31000020	CHIP FERRITE BLM11B252SD	FN31000020	Q381		HC10016880	IC CS4338 DAC 8PIN 24BIT 96KHz	HC10016880
R381		nsp	CHIP 220kΩ ±5% 1/16W	NN05224610	Q382		HC10011090	IC NJM4558M Y	HC10011090
R382		nsp	CHIP 220kΩ ±5% 1/16W	NN05224610	Q383		HX346721A0	CHIP TRS. 2SC4672 Q	HX346721A0
R383					QU51		HU02ATN00F	IC μP784217AGC-192-8EU	HU02ATN00F
}		nsp	CHIP 10kΩ ±5% 1/16W	NN05103610	QU52		HC10224210	IC BD4742G RESET IC 4.2V	HC10224210
R386					QU53		HX300012A0	CHIP TRS.	HX300012A0
R387		nsp	CHIP 18kΩ ±5% 1/16W	NN05183610					
R388		nsp	CHIP 18kΩ ±5% 1/16W	NN05183610					
R389		nsp	CHIP 33kΩ ±5% 1/16W	NN05333610	QU61		BA20021210	DIG.TR.S. DTC144EC	BA20021210
R390		nsp	CHIP 33kΩ ±5% 1/16W	NN05333610	QU62		BA10014210	DIG.TR.S. DTA144EU	BA10014210
R391		nsp	CHIP 0Ω ±5% 1/16W	NN05000610	QU63		BA20021210	DIG.TR.S. DTC144EC	BA20021210
R392		nsp	CHIP 0Ω ±5% 1/16W	NN05000610	QU64		BA10014210	DIG.TR.S. DTA144EU	BA10014210

NOTE : "nsp" PART IS LISTED FOR REFERENCE ONLY, MARANTZ WILL NOT SUPPLY THESE PARTS.

POS. NO	VERS. COLOR	PART NO. (FOR EUR)	DESCRIPTION	PART NO. (MJI)	POS. NO	VERS. COLOR	PART NO. (FOR EUR)	DESCRIPTION	PART NO. (MJI)
L301		FC90020110	<b>PS01-MISCELLANEOUS</b> CHIP FERRITE BLM11B601S	FC90020110	SY01			<b>PY03-MISCELLANEOUS</b>	
L302		FN31000020	CHIP FERRITE BLM11B252SD	FN31000020	}		SP01012030	PUSH SWITCH SKHVBF 260GF	SP01012030
L303		FC90020110	CHIP FERRITE BLM11B601S	FC90020110	SY04			RED	
L351		FC90020110	CHIP FERRITE BLM11B601S	FC90020110	SY05		SS02040040	SLIDE SWITCH REV. MODE SW	SS02040040
L381								SSSU024-P06N1	
}		FC90020110	CHIP FERRITE BLM11B601S	FC90020110	SY06		SS02030370	SLIDE SWITCH SSSU0 2-3	SS02030370
L384								DOLBY SW	
L385		FN31000020	CHIP FERRITE BLM11B252SD	FN31000020	SY07		SS02021250	SLIDE SWITCH SSSU L=6MM	SS02021250
L386		FC90020110	CHIP FERRITE BLM11B601S	FC90020110				ALC SW	
L387			CHIP 220Ω ±5% 1/16W	NN05221610	VY01		HQ30802920	DISPLAY UNIT CR2095C FOR	HQ30802920
X301		JX08001320	CRYSTAL CM309S 8.4672MHz	JX08001320				CD/TAPE FL	
XU51		FQ01005020	CERAMIC VIB. CSTCC10.0MG RESONATOR 10MHz	FQ01005020					
			<b>PS03-POWER SW CIRCUIT BOARD</b>		<b>R***</b>			<b>PY13-DISPLAY CIRCUIT BOARD SUB PY13- RESISTORS (COMMON)</b> CARBON FILM FIXED RES. ±5% 1/6W : RY24-RY27 RY30-RY33	
▲ C831		DK17103900	CER. DE1610F 103M-KH	DK17103900					
▲ L831		FN01020020	LINE FILTER LF-4D-102	FN01020020					
▲ S831		SP01011830	PUSH SWITCH SDDL B TV-3 F-TYPE C E-TYPE4	SP01011830	DY21		nsp	<b>PY13-SEMICONDUCTORS</b> DIODE	HD20002000
			<b>PT03-POWER TRANS CIRCUIT BOARD</b>		}			1SS176 MA165 1SS254 30V 0.1A	
▲ L001	/N	TS15724210	MAINS TRANSF 200V 230V 240V	TS15724210	DY27				
▲ L001	/U		MAINS TRANSF. FOR U/C	TS15724200				<b>PY23-MECHA KEY CIRCUIT BOARD PY23- RESISTORS (COMMON)</b> CARBON FILM FIXED RES. ±5% 1/6W : RY71-RY73	
			<b>PV03-HP. AMP CIRCUIT BOARD PV03-CAPACITORS</b>		<b>R***</b>			<b>PY23-SEMICONDUCTORS</b>	
CV03		EA47601620	ELECT. 47µF 16V	EA47601620	DY71		nsp	DIODE	HD20002000
CV04		EA47601620	ELECT. 47µF 16V	EA47601620	}			1SS176 MA165 1SS254 30V 0.1A	
CV05		nsp	ELECT. 220µF 10V	EA22701010	DY79		HI10114320	L.E.D. LT3K8B GREEN TAPE FWD.	HI10114320
CV06		nsp	ELECT. 100µF M 16V RA-2	OA10701620	DY81		HI10114320	L.E.D. LT3K8B GREEN TAPE REV.	HI10114320
			<b>PV03- RESISTORS (COMMON)</b> CARBON FILM FIXED RES. ±5% 1/6W : RV01-RV18		DY82		HI10114320	L.E.D. LT3K8B GREEN CD PLAY	HI10114320
			<b>PV03-SEMICONDUCTOR</b>		DY83				
QV01		HC10007090	IC NJM4560D	HC10007090	SY71			<b>PY23-MISCELLANEOUS</b>	
JV02		YJ01003020	JACK PHONE JACKS	YJ01003020	}		SP01013310	TACT SW. SKQNAEH/5MM 160GF	SP01013310
SV01		SR02030200	ROTARY SWITCH SRBM13N-F15 2-3 N S HP SELECTOR	SR02030200	SY79				
			<b>PY03-DISPLAY CIRCUIT BOARD PY03-CAPACITOR</b>					<b>PY33-CD FUNC. KEY CIRCUIT BOARD PY33-SEMICONDUCTORS</b>	
CY02		nsp	ELECT. 100µF M 10V RA-2	OA10701020	DY51		nsp	DIODE	HD20002000
			<b>PY03-RESISTOR</b> VAR. 5kΩ B CT CC L=12.5 RK11K114	RK05020530	DY57			1SS176 MA165 1SS254 30V 0.1A	
RY51		RK05020530		RK05020530	SY51		SP01013310	<b>PY33-MISCELLANEOUS</b> TACT SW. SKQNAEH/5MM 160GF	SP01013310
			<b>PY03- RESISTORS (COMMON)</b> CARBON FILM FIXED RES. ±5% 1/6W : RY01 RY21-RY23 RY28		}				
			<b>PY03-SEMICONDUCTORS</b>		SY57				
DY01		nsp	DIODE	HD20002000					
}			1SS176 MA165 1SS254 30V 0.1A						
DY07		HI10062320	L.E.D. LT3D8B RED 30 REC IND.	HI10062320					
DY08		HW10004210	PHOTO UNIT RPM6936-V4	HW10004210					
DY10			IR SENSOR						
QY01		HC10283060	IC UPD16311GC-AB6 FTD DRIVER	HC10283060					
QY02		HT10001000	TRS. A1048 A933S A1267 ETC.	HT10001000					

NOTE : "nsp" PART IS LISTED FOR REFERENCE ONLY, MARANTZ WILL NOT SUPPLY THESE PARTS.