

# Service Manual

PMD520/F1B

## Fully Independent Double Cassette Deck

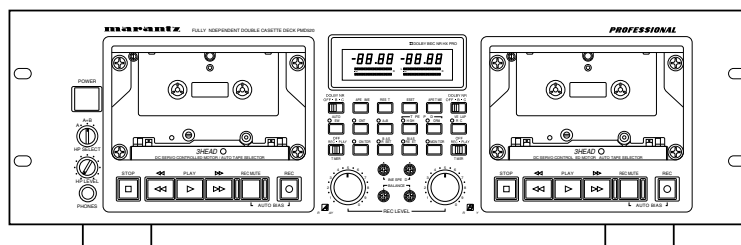

PMD520FBは74PMD520/02B PMD520Uの電源部分の変更及び入力ATT回路(PA01)を追加した製品です。このサービスマニュアルには74PMD520/02B PMD520Uとの相違部分のみを記載しております。その他の部分は74PMD520/02B PMD520Uのサービスマニュアル(418S855010または4822 725 51174)を参照して下さい。

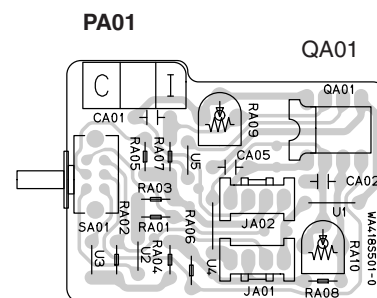
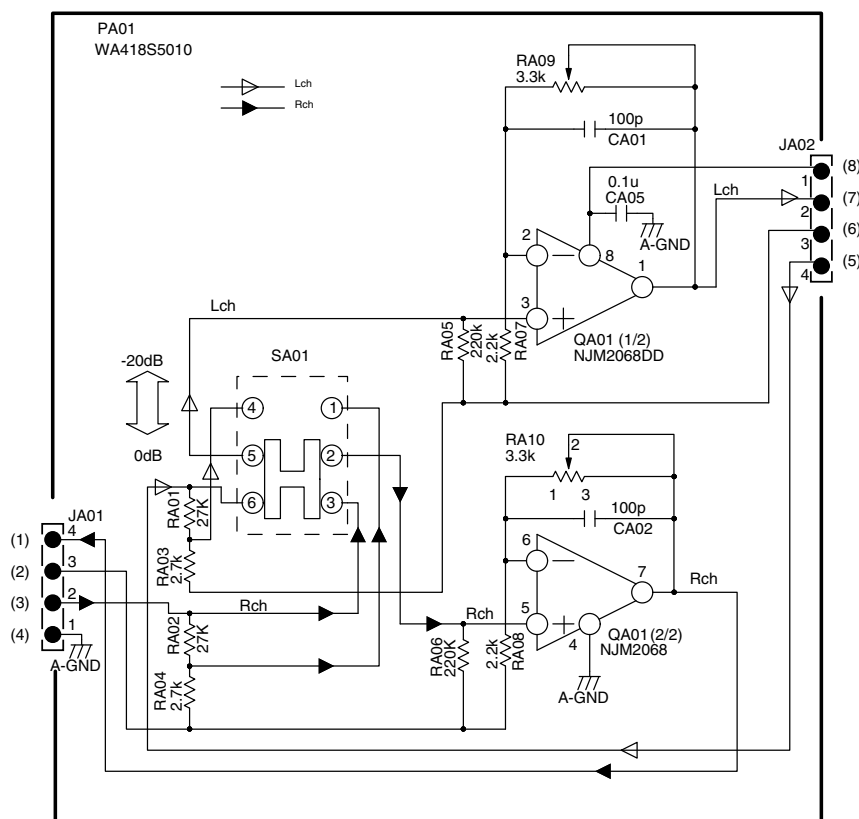

修理の際は、必ず取扱説明書を準備し操作方法を確認の上作業を行ってください。

# marantz®

## PMD520

Pos. No.	PARTS NO.	DESCRIPTION	Page	
PA01		ATT CIRCUIT BOARD	PA01 New	
CA01	DK16101300	100pF K 50V	PA01 New	
CA02	DK16101300	100pF K 50V	PA01 New	
CA05	DD38104010	0.1μF +80%-20% 50V DC	PA01 New	
RA01	GD05273160	27kΩ ±5% 1/6W	PA01 New	
RA02	GD05273160	27kΩ ±5% 1/6W	PA01 New	
RA03	GD05272160	2.7kΩ ±5% 1/6W	PA01 New	
RA04	GD05272160	2.7kΩ ±5% 1/6W	PA01 New	
RA05	GD05224160	220kΩ ±5% 1/6W	PA01 New	
RA06	GD05224160	220kΩ ±5% 1/6W	PA01 New	
RA07	GD05222160	2.2kΩ ±5% 1/6W	PA01 New	
RA08	GD05222160	2.2kΩ ±5% 1/6W	PA01 New	
RA09	RA03320780	VR. 3.3kΩ	PA01 New	
RA10	RA03320780	VR. 3.3kΩ	PA01 New	
QA01	HC10053090	IC NJM-2068-DD	PA01 New	
SA01	SS02021710	SW. SSAA22-B NON-SHORTING	PA01 New	
QU01	*HS418ST1R	Microprocessor(programmed) TMP87PM41N	P800 59p	
▲	J092	YJ04002360	AC INLET 2P SOT-16C	Exv. 47p
▲	L001	TS15725180	MAINS TRANSF.	Exv. 47p
▲	W001	ZC01801050	MAINS CORD FOR JAPAN	Exv. 47p
	002T	418S851110	USER GUIDE	Exv. 47p

【 変更追加は以下の部分 】

## 1. TECHNICAL SPECIFICATIONS

### Input Sensitivity

Line A (F) ..... 1V

Line B (F) ..... 100mV

### Input Impedance

Line A (F) ..... 25kΩ

Line B (F) ..... 100kΩ

### Power Supply

#### Power Requirement

F Version ..... 100V AC 50/60Hz

## 2. LEVEL DIAGRAM

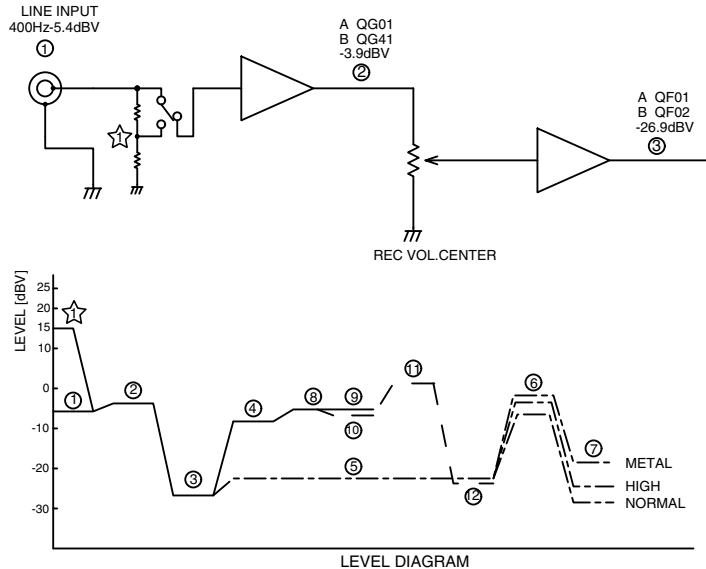

### 3. BLOCK DIAGRAM

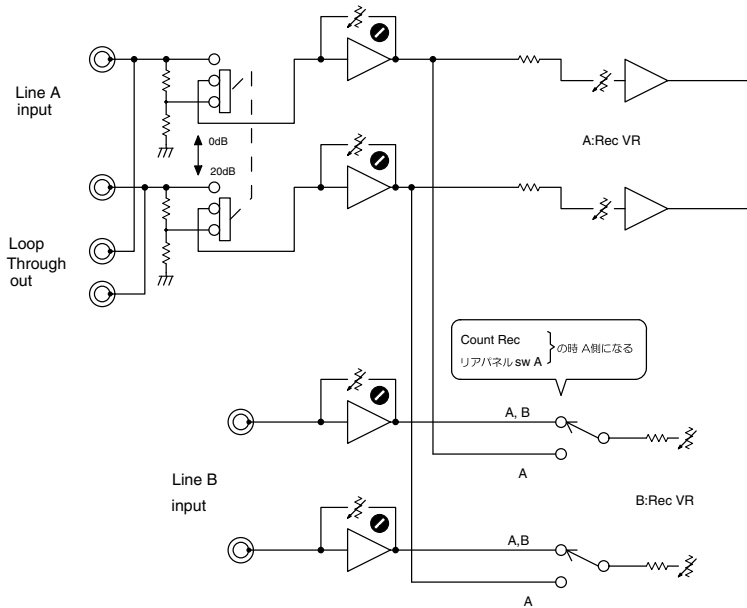

### 4. CONNECTION DIAGRAM

・ PA01 は PGO1 基板上にコネクタでマウントされています。

### 5. SCHEMATIC DIAGRAM

・ LINE A OUT LEVEL ADJ 部 (PG01 1/8:13p 参照)

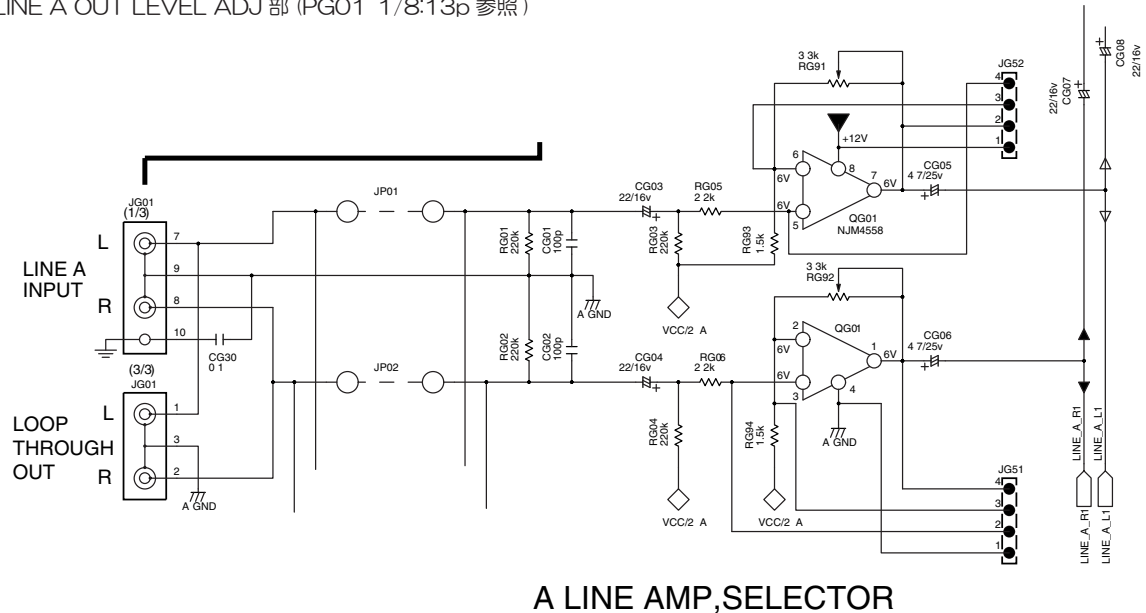

A LINE AMP, SELECTOR

・ 電源部は USA Version と同じ回路図 (P851:31p 参照)

## 6. EXPLODED VIEW

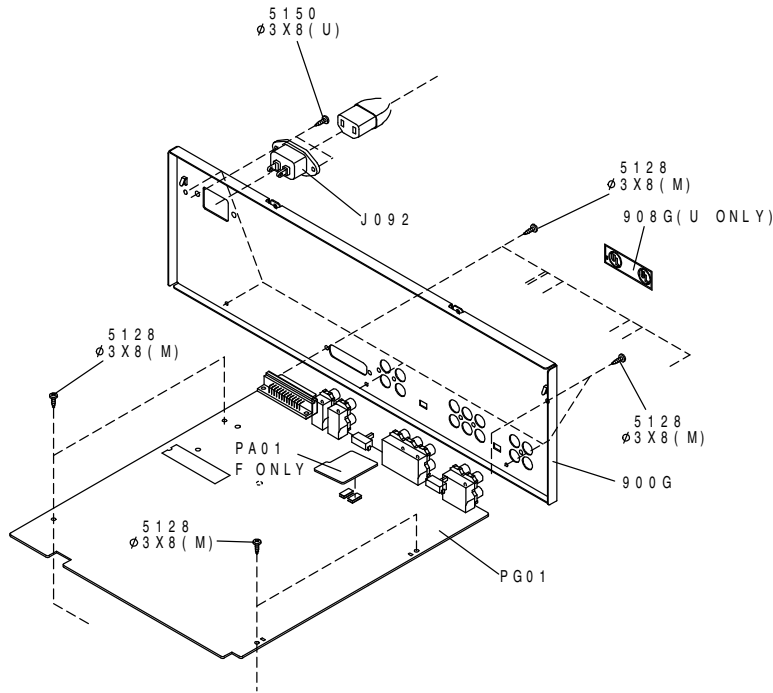

## 9. ELECTRICAL ADJUSTMENTS

・調整部は3箇所 (51p, 53p 参照)

### 2. S.R.L Setting

- 1) Apply a 1kHz, Line A : 1100 mV(F) / 100 mV(U, /02), Line B : 100 mV to the LINE INPUT jacks.
- 2) Put the unit in RECORD mode and adjust the REC LEVEL control to obtain 388 mV of signal at the DOLBY test points J601 (Deck A) and J651 (Deck B).
- 3) Adjust the output of the audio oscillator applied to the LINE INPUT jacks to 70.8 mV (-3 dB). This is the rated recording condition for the STANDARD RECORDING LEVEL (S.R.L.).

### 9.4 LINE OUTPUT LEVEL ADJUSTMENT

- 1) Connect the audio oscillator to the LINE INPUT jacks.
- 2) Connect the VTVM to LINE OUTPUT jacks.
- 3) Set the MONITOR switch to the source position.
- 4) Set the REC volume to the center click position.
- 5) Supply 100 mV to the LINE INPUT jacks.
- 6) Adjust the following semi-fixed resistor to set Line A : 1100 mV(F) / 100 mV(U, /02), Line B : 100 mV from the LINE OUTPUT jacks;

注 : Line A は SW. : SA01 (PA01) を 20dB 側にする。

CH.	ADJUSTMENT POINT	MECHA.	Ver.
L	RA09 (SA01:-20dB, PA01)	A	F
R	RA10 (SA01:-20dB, PA01)	A	F
L	RG91	A	U, /02
R	RG92	A	U, /02
L	RG95	B	
R	RG96	B	

### 9.7 REC/PLAY-BACK FREQUENCY RESPONSE ADJUSTMENT

- 1) Insert the AC-225 tape in the holder.
- 2) Set the REC volume to the center position.
- 3) Supply 1kHz Line A : 330 mV(F) / 30 mV(U, /02), Line B : 30 mV to the line input jacks.
- 4) Record the 400Hz and 12.5kHz signals by turns.
- 5) Playback the section just recorded, and adjust the following semi-fixed resistor so that the level of differences between 400Hz and 12.5kHz are within 1.0dB;

CH.	ADJUSTMENT POINT	MECHA.
L	R901	A
R	R902	A
L	R951	B
R	R952	B

- 6) Only check HIGH POSITION and METAL tapes.