

# Service Manual

PMD570 /F1B /N1B /U1B  
/F1S /N1S /U1S  
Solid State Recorder

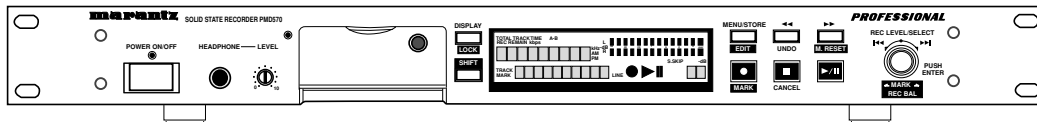

## TABLE OF CONTENTS

SECTION	PAGE
1. TECHNICAL SPECIFICATIONS .....	1
2. SERVICE MODE .....	2
3. LCD CONTRAST ADJUSTMENT .....	3
4. MAIN MICROPROCESSOR (QU01) UPDATE PROCEDURE .....	3
5. WIRING DIAGRAM .....	19
6. BLOCK DIAGRAM .....	21
7. SCHEMATIC DIAGRAM .....	23
8. PARTS LOCATION .....	49
9. MICROPROCESSOR AND IC DATA .....	55
10. EXPLODED VIEW AND PARTS LIST .....	69
11. ELECTRICAL PARTS LIST .....	73

Please use this service manual with referring to the user guide (D.F.U) without fail.  
修理の際は、必ず取扱説明書を準備し操作方法を確認の上作業を行ってください。

# marantz®

## PMD570

## MARANTZ DESIGN AND SERVICE

Using superior design and selected high grade components, **MARANTZ** company has created the ultimate in stereo sound. Only original **MARANTZ** parts can insure that your **MARANTZ** product will continue to perform to the specifications for which it is famous.

Parts for your **MARANTZ** equipment are generally available to our National Marantz Subsidiary or Agent.

### ORDERING PARTS :

Parts can be ordered either by mail or by Fax.. In both cases, the correct part number has to be specified.

The following information must be supplied to eliminate delays in processing your order :

1. Complete address
2. Complete part numbers and quantities required
3. Description of parts
4. Model number for which part is required
5. Way of shipment
6. Signature : any order form or Fax. must be signed, otherwise such part order will be considered as null and void.

#### USA

**MARANTZ AMERICA, INC**  
1100 MAPLEWOOD DRIVE  
ITASCA, IL. 60143  
USA  
PHONE : 630 - 741 - 0300  
FAX : 630 - 741 - 0301

#### EUROPE / TRADING

**MARANTZ EUROPE B.V.**  
P. O. BOX 8744, BUILDING SILVERPOINT  
BEEMDSTRAAT 11, 5653 MA EINDHOVEN  
THE NETHERLANDS  
PHONE : +31 - 40 - 2507844  
FAX : +31 - 40 - 2507860

#### CANADA

**MARANTZ CANADA INC.**  
5-505 APPLE CREEK BLVD.  
MARKHAM, ONTARIO L3R 5B1  
CANADA  
PHONE : 905 - 415 - 9292  
FAX : 905 - 475 - 4159

#### PROFESSIONAL AMERICAS

**SUPERSCOPE TECHNOLOGIES, INC.**  
MARANTZ PROFESSIONAL PRODUCTS  
2640 WHITE OAK CIRCLE, SUITE A  
AURORA, ILLINOIS 60504 USA  
PHONE : 630 - 820 - 4800  
FAX : 630 - 820 - 8103

#### PROFESSIONAL AUSTRALIA

**TECHNICAL AUDIO GROUP PTY, LTD**  
43-53 Bridge Rd.,  
STANMORE NSW 2048  
AUSTRALIA  
PHONE : +61 - (0)2 - 9519 - 0900  
FAX : +61 - (0)2 - 9519 - 0600

#### PROFESSIONAL HONG KONG

**Jolly ProAudio Broadcast Engineering Ltd.**  
UNIT 2, 10F, WAH HUNG CENTRE,  
41 HUNG TO ROAD, KWUN TONG, KLN.,  
HONG KONG  
PHONE : 852 - 21913660  
FAX : 852 - 21913990

#### AUSTRALIA

**QualiFi Pty Ltd,**  
24 LIONEL ROAD,  
MT. WAVERLEY VIC 3149  
AUSTRALIA  
PHONE : +61 - (0)3 - 9543 - 1522  
FAX : +61 - (0)3 - 9543 - 3677

#### THAILAND

**MRZ STANDARD CO., LTD**  
746 - 754 MAHACHAI ROAD.,  
WANGBURAPAPIROM, PHRANAKORN,  
BANGKOK, 10200 THAILAND  
PHONE : +66 - 2 - 222 9181  
FAX : +66 - 2 - 224 6795

#### SINGAPORE

**WO KEE HONG DISTRIBUTION PTE LTD**  
No.1 JALAN KILANG TIMOR  
#08-03 PACIFIC TECH CENTRE  
SINGAPORE 159303  
PHONE : +65 6376 0338  
FAX : +65 6376 0166

#### NEW ZEALAND

**WILDASH AUDIO SYSTEMS NZ**  
14 MALVERN ROAD MT ALBERT  
AUCKLAND NEW ZEALAND  
PHONE : +64 - 9 - 8451958  
FAX : +64 - 9 - 8463554

#### TAIWAN

**PAI- YUING CO., LTD.**  
6 TH FL NO, 148 SUNG KIANG ROAD,  
TAIPEI, 10429, TAIWAN R.O.C.  
PHONE : +886 - 2 - 25221304  
FAX : +886 - 2 - 25630415

#### MALAYSIA

**WO KEE HONG ELECTRONICS SDN. BHD.**  
2ND FLOOR BANGUNAN INFINITE CENTRE  
LOT 1, JALAN 13/6, 46200 PETALING JAYA  
SELANGOR DARUL EHSAN, MALAYSIA  
PHONE : +60 - 3 - 7954 8088  
FAX : +60 - 3 - 7954 7088

#### JAPAN *Technical*

**MARANTZ JAPAN, INC.**  
35- 1, 7- CHOME, SAGAMIONO  
SAGAMIHARA - SHI, KANAGAWA  
JAPAN 228-8505  
PHONE : +81 42 748 1013  
FAX : +81 42 741 9190

#### 日本マランツ株式会社

本社 〒228-8505  
神奈川県相模原市相模大野7-35-1

#### KOREA

**MK ENTERPRISES LTD.**  
ROOM 604/605, ELECTRO-OFFICETEL, 16-58,  
3GA, HANGANG-RO, YONGSAN-KU, SEOUL  
KOREA  
PHONE : +822 - 3232 - 155  
FAX : +822 - 3232 - 154

### SHOCK, FIRE HAZARD SERVICE TEST :

**CAUTION :** After servicing this appliance and prior to returning to customer, measure the resistance between either primary AC cord connector pins ( with unit NOT connected to AC mains and its Power switch ON ), and the face or Front Panel of product and controls and chassis bottom.

Any resistance measurement less than 1 Megohms should cause unit to be repaired or corrected before AC power is applied, and verified before it is return to the user/customer.

Ref. UL Standard No. 1492.

In case of difficulties, do not hesitate to contact the Technical Department at above mentioned address.

# 1. TECHNICAL SPECIFICATIONS

## Digital audio system

System ..... Solid State Recorder  
Usable Media ..... CF memory cards  
(Microdrive) cards

### Recording and media methods

.mp2 ..... MPEG1 Layer II compression  
.mp3 ..... MPEG1 Layer III compression  
.mp3 ..... MPEG2 Layer III compression\*  
\*for all half sample rates.

PCM ..... 16 bit linear PCM

### Recording bit rate (selectable)

MP2 mono ..... 192, 128, 96, 64, 48, 32 kbps  
MP2 stereo ..... 384, 256, 192, 128, 96, 64 kbps  
MP3 mono ..... 160, 128, 80, 64, 40, 32 kbps  
MP3 stereo ..... 320, 256, 160, 128, 80, 64 kbps

### Sampling frequency

Analog ..... 48, 44.1, 32, 24\*, 22.05\*, 16\* kHz  
\*except MP2

Digital ..... 48, 44.1 kHz

Number of channels ..... 2 (stereo), 1 (mono)

## Audio

Frequency response ..... 20,000 Hz (-0.5dB)

### Signal-to-Noise Ratio

IEC-A weighted ..... 91 dB

### Total Harmonic Distortion

at 0 VU (PCM) ..... 0.01%

Dynamic Range ..... 94 dB

## Inputs

### BALANCED IN L/R

Type ..... XLR (1:GND, 2:HOT, 3:COLD)

Input Sensitivity ..... +16dBu/@0dBFS  
(+4dBu/@-12dBFS) / 24 kohms

Trim Control ..... 0 to 24dB

### LINE IN L/R

Type ..... RCA jack

Input Sensitivity ..... 500 mVrms/22 kohms

### DIGITAL IN

Type ..... RCA jack

Input impedance ..... 75 ohms

Standard input level ..... 0.5 Vp-p

Sampling frequency ..... 44.1/48 kHz

Format ..... SPDIF (IEC 958 Typell)

## Outputs

### LINE OUT L/R

Type ..... RCA jack

Standard level ..... 2 Vrms max./300 ohms

### DIGITAL OUT

Type ..... RCA jack

Output impedance ..... 75 ohms

Standard output level ..... 0.5 Vp-p

Sampling frequency ..... 44.1/48 kHz

Format ..... SPDIF (IEC-958 Type II)

## General

### Power requirements

Japan model ..... AC100V 50/60Hz

US model ..... AC120V 60Hz

European model ..... AC100 – 240V 50/60Hz

Power consumption ..... 5.3W

Headphone Output power ..... 20 mW/32 ohms

### Dimensions

Width ..... 483 mm

Height ..... 52 mm

Depth ..... 298 mm

Weight ..... 3.0 kg

### Included accessories

CF card\* (64MB) ..... 1

Power cord ..... 1

I/O cable ..... 1

Stereo audio cables ..... 2

Screw (ISO 3x10 mm) ..... 2

Plastic pin and retainer ..... 1

User Guide ..... 1

\* A CF card (Compact Flash™ memory card) or a Microdrive™ is needed for the PMD570 to work. Also used in digital cameras, removable flash memory media are widely available at consumer electronics retailers and computer resellers. Removable flash memory media come in a variety of sizes and connection configurations. The PMD570 accepts "Compact Flash" and "Microdrive" media.

The recording time depends on the size of the CF card and the recording parameters.

## Optional Accessories

(See [www.d-mpro.com](http://www.d-mpro.com) for descriptions and/or ordering information.)

### Remote control

Model RC600 ..... wired remote  
start recording, pause recording, add EDL marks

## 2. SERVICE MODE

### 2.1. Micro Processor Version check

1. Keep inserting the CompactFlash, press the **POWER** button while pressing **MENU/STORE** and **REC** button. (**MENU/STORE** and **REC** button are pushed 3 seconds or more.)
2. VERSION name is displayed on LCD with blink, then press **PLAY/PAUSE** button, VERSION is displayed on LCD.

Example : DSP 01.20  
MPU B0022

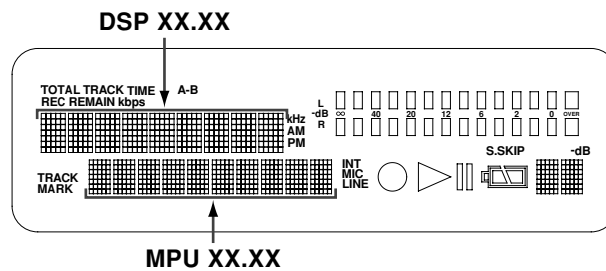

3. Turn off power to quit Service mode.

### 2.2. CompactFlash read/write speed check

1. Insert the CompactFlash, Press the **POWER** button while pressing **MENU/STORE** and **REC** button. (**MENU/STORE** and **REC** button are pushed 3 seconds or more.)
2. VERSION name is displayed on LCD with blink, then press **▶▶** (FWD) or **◀◀** (REW) button. **CARD CHECK** name is displayed on LCD.
3. Then press **PLAY/PAUSE** button. **CARD CHECK** name is displayed on LCD. after **Good** or **No Good** is displayed on LCD.  
If "No good" is displayed, the CompactFlash is not correct. Insert the correct CompactFlash.  
Because read/write speed is slow, the unit has the possibility that sound is interrupted and stop during recording.
4. Turn off power to quit Service mode.

## 2. SERVICE モード

### 2.1. VERSION 確認

1. Compact Flashが挿入されている状態で、**MENU/STORE** ボタンと **REC** ボタンを押しながら **POWER** ボタンを押します。(3秒以上 **MENU/STORE** ボタンと **REC** ボタンを押します。)
2. DISPLAYにVERSIONと点滅表示されたら**PLAY/PAUSE** ボタンを押してバージョンを確認します。

表示例 : DSP 01.20  
MPU B0022

3. SERVICE モード解除は、電源を切ります。

### 2.2. Compact Flash 書換え速度確認

1. Compact Flashが挿入されている状態で、**MENU/STORE** ボタンと **REC** ボタンを押しながら **POWER** ボタンを押します。(3秒以上 **MENU/STORE** ボタンと **REC** ボタンを押します。)
2. DISPLAYにVERSIONと点滅表示されたら、**▶▶** (FWD) ボタンまたは **◀◀** (REW) ボタンを押すと、DISPLAYに **CARD CHECK** と表示されます。
3. さらに、**PLAY/PAUSE** ボタンを押すと、DISPLAYに **Check speed** と表示されたのち、**Good** または **No Good** が表示されます。  
**No Good** の場合：書き換え速度が遅い為、録音途中で止まる、または音切れが発生する可能性があります。CompactFlashを別の物に交換して下さい。
4. SERVICE モード解除は、電源を切ります。

### 3. LCD CONTRAST ADJUSTMENT

1. Connect the TEST POINT (See below) with the tester.
2. Turn the variable resistor RF01 so that the reading of the tester becomes  $7.0\text{ V} \pm 0.1\text{ V}$  and confirm the contrast of the LCD becomes maximum.

### 3. LCD 輝度電圧調整

LCDモジュールとメイン基板(PF01)をペアとして以下の調整をおこなってください。

1. TEST POINT JF02 にテスターを接続し、輝度電圧を測りながらボリュームRF01の抵抗値を調整します。
2. LCDを正面から見て、コントラストが最大になることを確認しながら輝度電圧を  $7.0\text{V} \pm 0.1\text{V}$  に調整します。

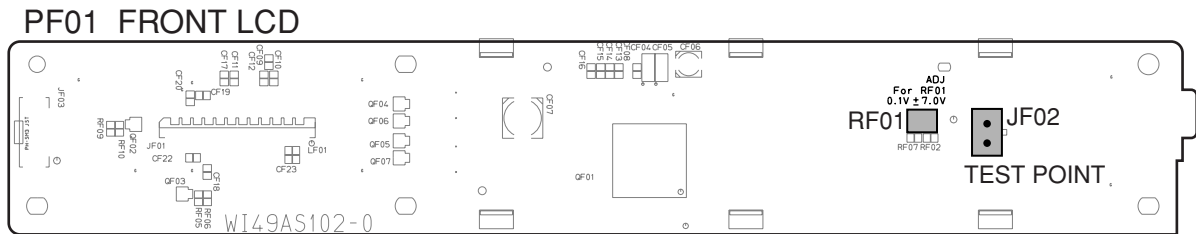

### 4. MAIN MICROPROCESSOR (QU01) UPDATE PROCEDURE

#### Necessary Equipment

- Windows PC (Windows2000 or WindowsXP) with COM port
- RS232C cable straight type (9pin female – 9Pin male )
- Update Disc (\*PMD570CDR)

### 4. Main microprocessor (QU01)

#### アップデート方法

#### 必要機器

- Windows PC (OS:Windows2000 または WindowsXP) で COM port のあるもの
- RS232C ストレートケーブル (9pin メス - 9pin オス)
- マイコンアップデートディスク (\*PMD570CDR)

#### 4.1. Connection

1. Connect COM port of Windows PC and PMD570 with RS232C cable.

#### 4.1. 接続方法

- 1 PMD570とWindows PCのCOMポートをRS232Cケーブルで接続します。

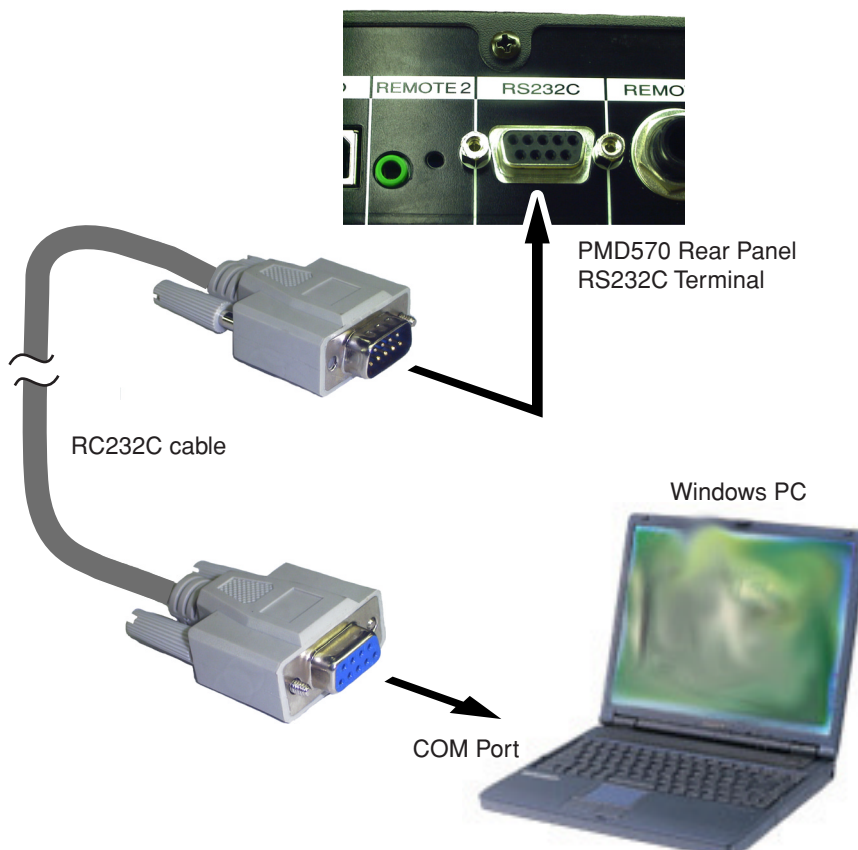

## 4.2. Installs of The software (Flash Development Toolkit 3.0)

1. Open the CD-ROM (\*PMD570CDR) Disc, and double click **soft** folder.

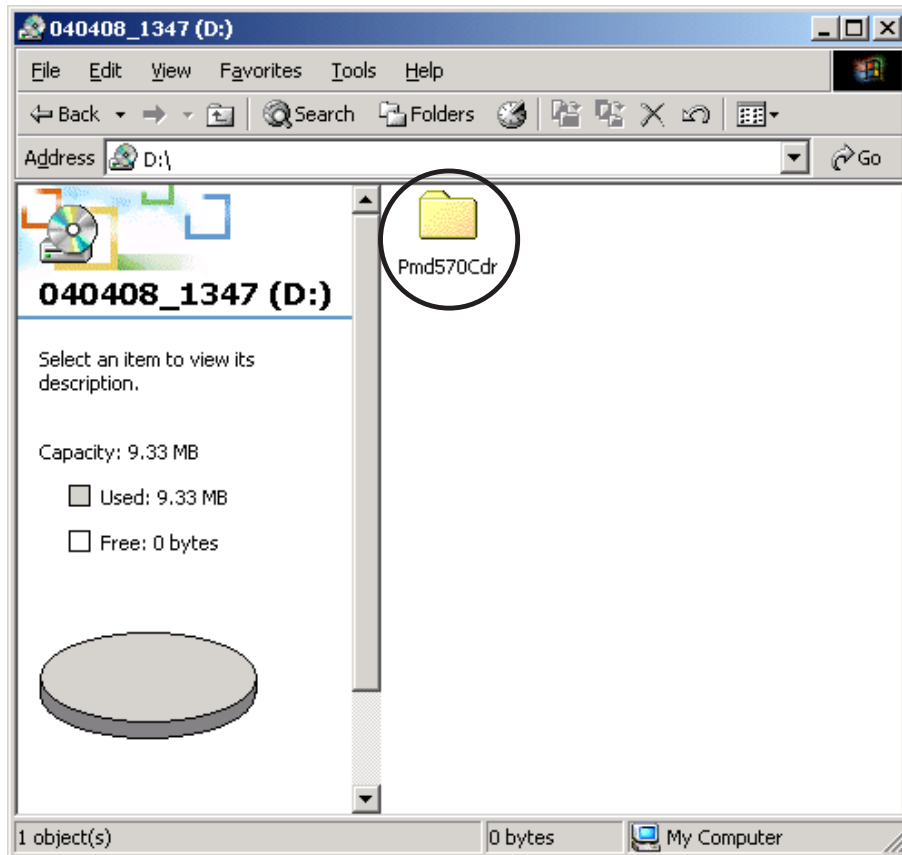

## 4.2. 書き込みソフトウェアのインストール (Flash Development Toolkit 3.0)

1. CD-ROM (\*PMD570CDR) の **soft** フォルダをダブルクリックします。

2. Double click the **FDT setup.exe**

2. **FDT setup.exe** をダブルクリックします。

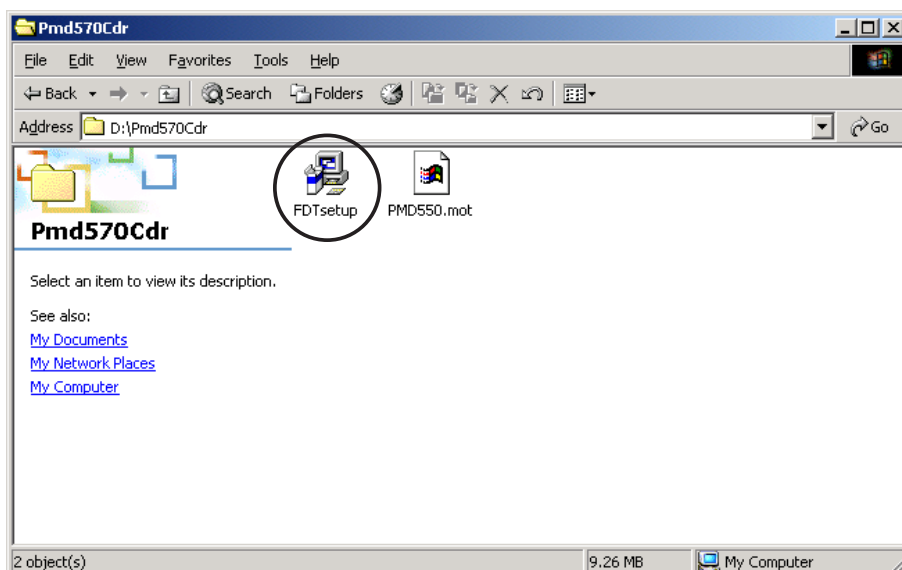

3. Click **Next**.

3. インストールウィザードが起動します。  
**Next** をクリックします。



4. Choose the language. And click **Next**.

4. 言語を選んで **Next** をクリックします。



5. Click **Yes**.

5. **Yes** をクリックします。

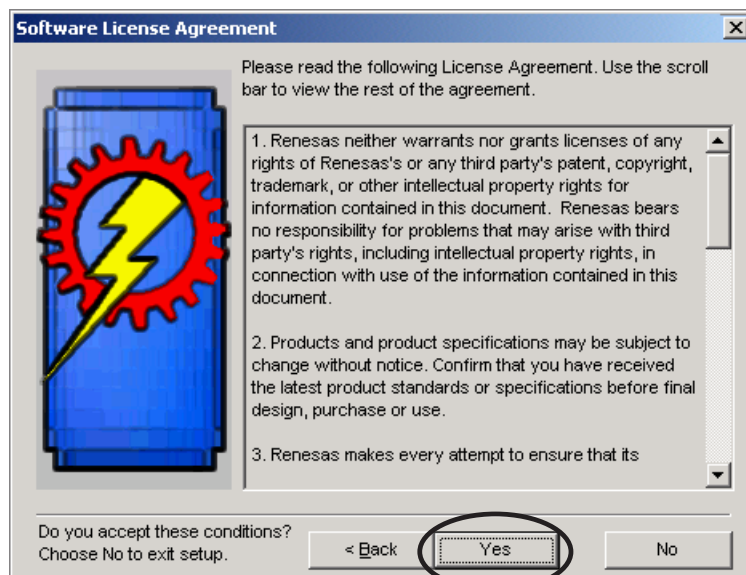

6. Check to the all check boxes. And click **Next**.

6. チェックボックス全てにチェックが入っていることを確認して **Next** をクリックします。

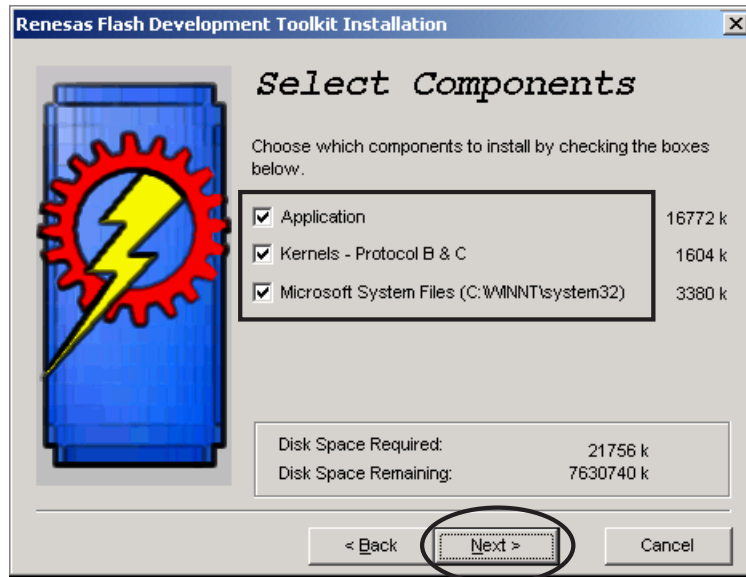

7. Click **Next**.

7. **Next** をクリックします。



8. Check to the all check boxes. And click **Next**.

8. チェックボックス全てにチェックが入っていることを確認して **Next** をクリックします。

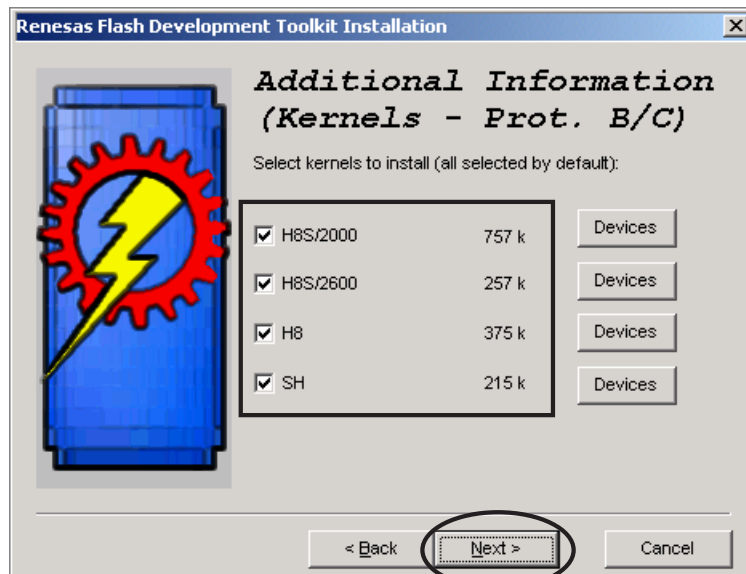



9. Click **Next**.

9. **Next** をクリックします。

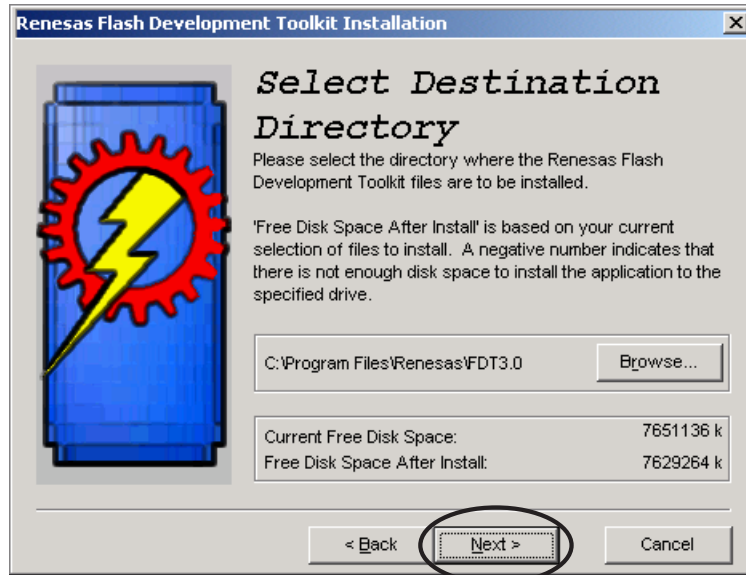

10. Click **Next**.

10. **Next** をクリックします。



11. Click **Next**.

11. **Next** をクリックします。

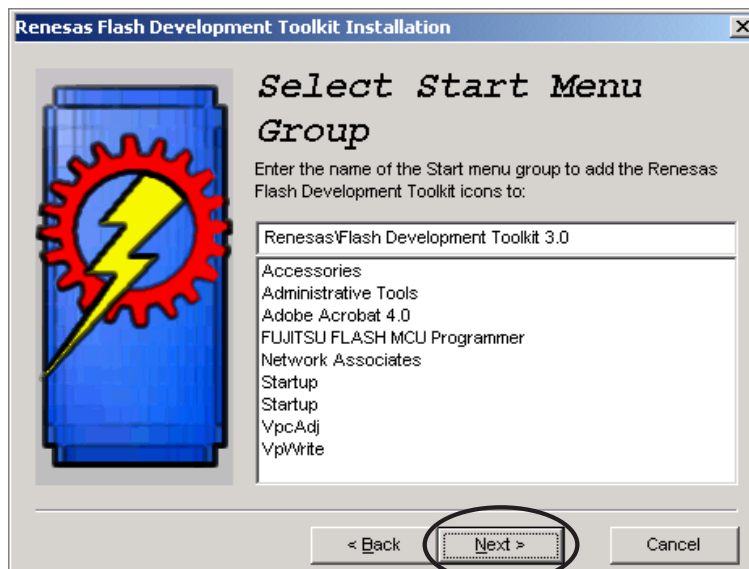

12. Click **Install**.

12. **Install** をクリックします。



13. The status bar appears.

13. インストールを開始します。

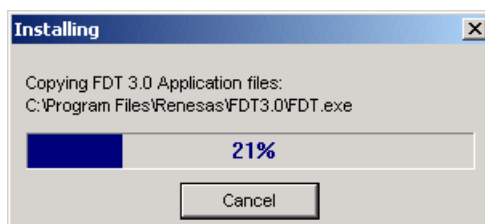

14. Click **Finish**.

14. **Finish** をクリックして書き込みソフトウェアのインストールを完了します。



### 4.3. The writing software setup procedure.

#### Launch up the writing software.

1. Click **Start / Programs / Renesas / Flash Development Toolkit 3.0 / Flash Development Toolkit 3.0**.

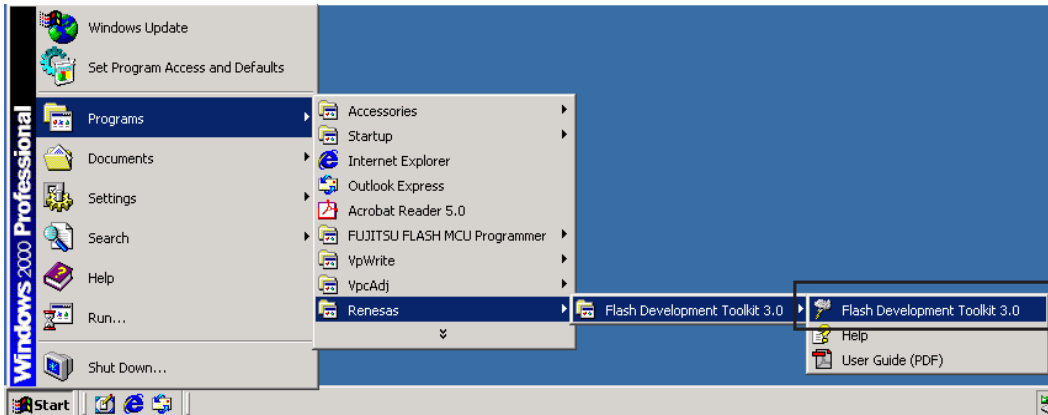

### 4.3. 書き込みソフトウェアの設定

#### ソフトウェアの起動

1. **Start / Programs / Renesas / Flash Development Toolkit 3.0 / Flash Development Toolkit 3.0** をクリックします。

2. Click **OK**. (This window appears at every starting.)

2. **OK**をクリックします。(起動のたびに下記のコマンドが出ますのでその都度**OK**をクリックしてください。)

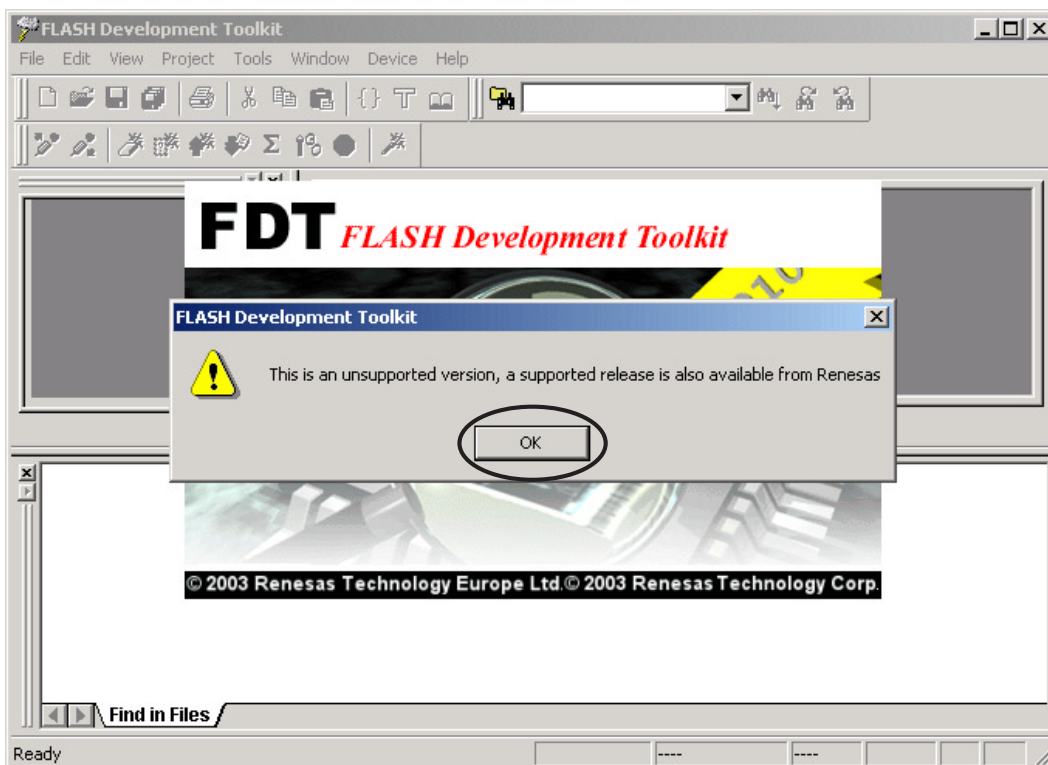

3. Check **Create a new project workspace**, and click **OK**.      3. **Create a new project workspace**にチェックを入れ、**OK**をクリックします。

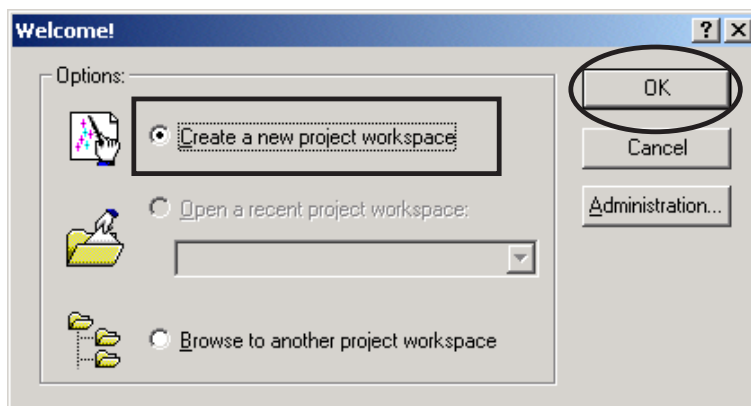

4. **PMD570** is inputted into the Workspace name.  
(It is simultaneously inputted into Project Name.)  
Click **OK**.

4. Workspace Nameに **PMD570**と入力します。  
(同時に Project Name にも入力されます。)  
**OK** をクリックします。

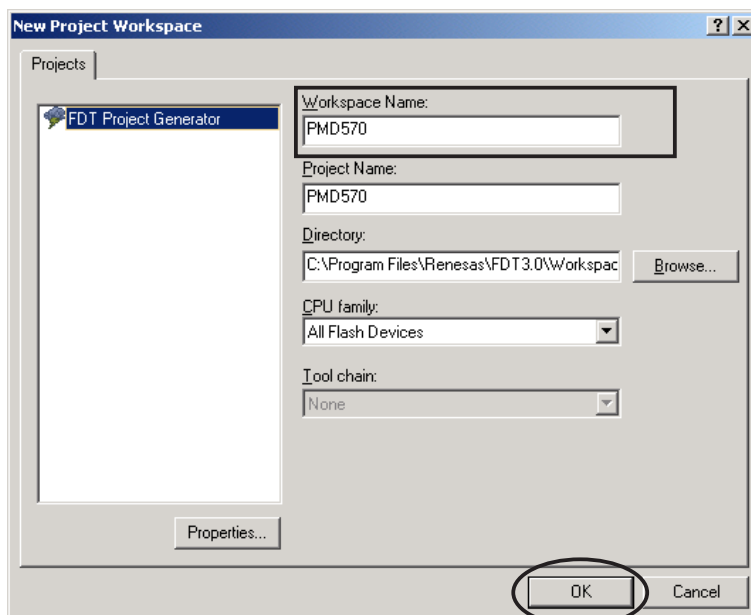

5. Choose the **H8S/2328F** in Select Device.  
Click **Next**.

5. Select Deviceから **H8S/2328F**を選び、クリックします。  
**Next** をクリックします。

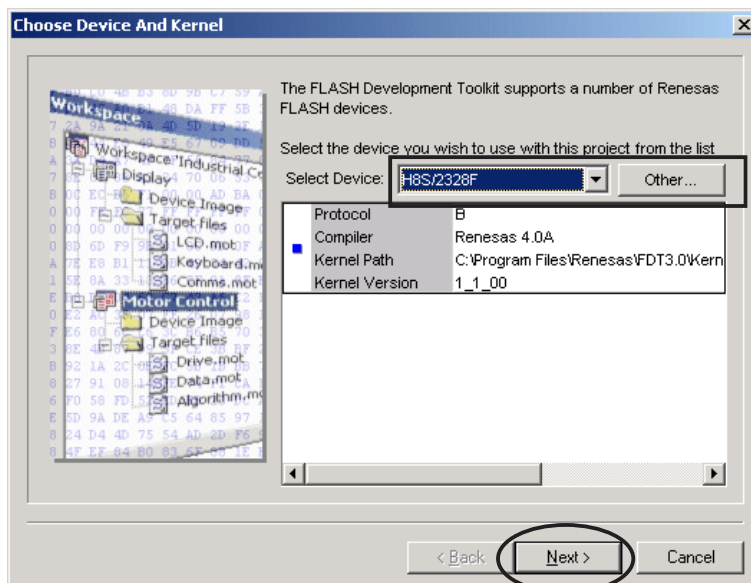

6. Choose the **Serial port No.** in the Select Port. Click **Next**.

6. Select Portから接続する**Serial Port**番号を選び、クリックします。**Next**をクリックします。

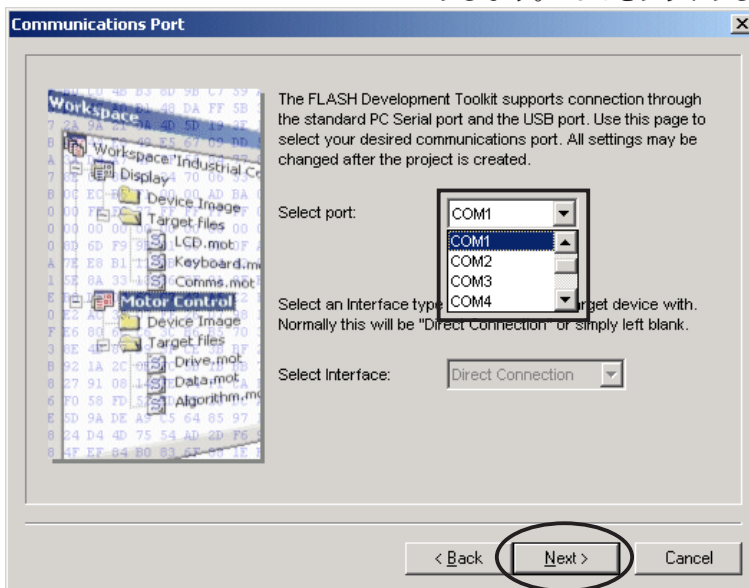

7. **24.58** is inputted into the "Enter the CPU crystal frequency for the selected device:". Click **Next**.

7. "Enter the CPU crystal frequency for the selected device:"に**24.58**と入力します。**Next**をクリックします。

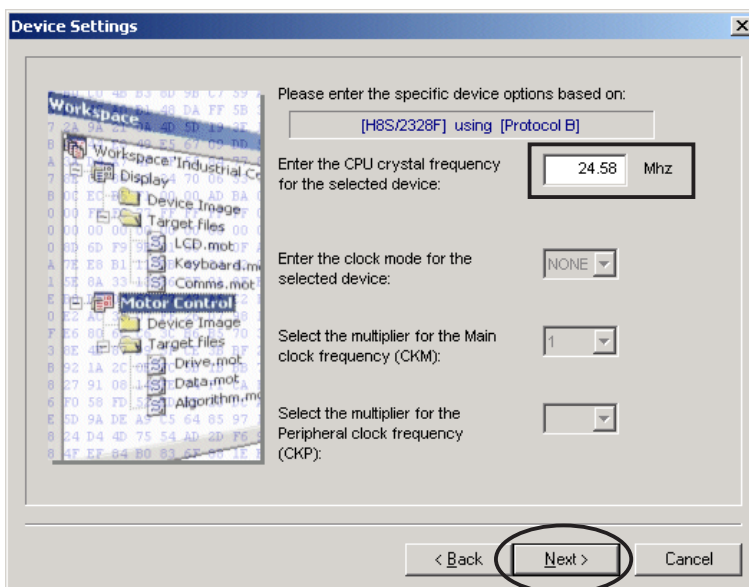

8. Check the **BOOT Mode** in Select Connection. Choose the **19200** in Select Baud rate. Click **Next**.

8. Select Connection:から**BOOT Mode**にチェックを入れます。Select Baud rate:から**19200**を選び、**Next**をクリックします。

**Remark:**

Please remove check mark, if it is contained in Use Default Baud Rate.

**注意**

Use Default Baud Rateにチェックが入っていると Baud Rate を変更できませんのでチェックを外してください。

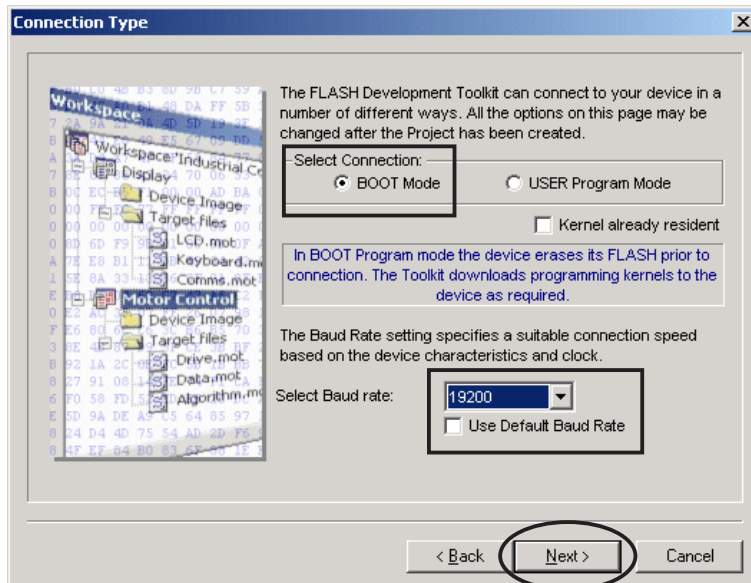

9. Check the **Automatic** in Protection.  
Check the **Advanced** in Messaging.  
Click **Finish**.

9. Protection から **Automatic** にチェックを入れます。  
Messaging から **Advanced** にチェックを入れます。  
**Finish** をクリックします。

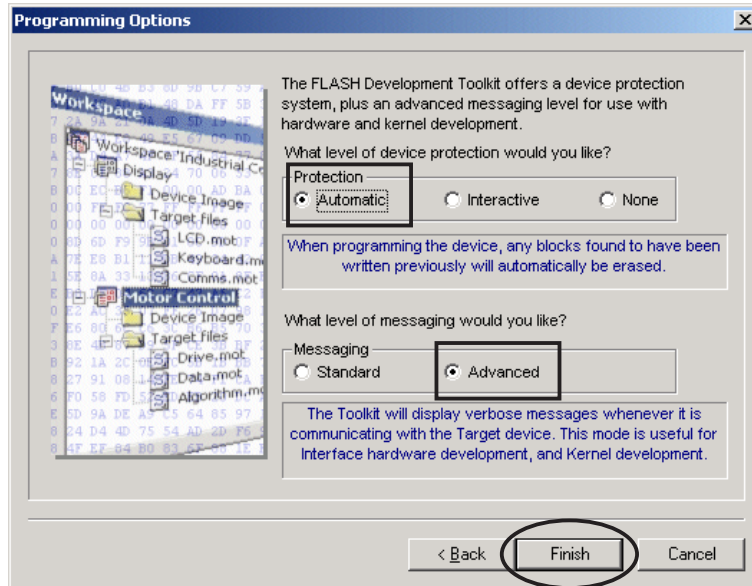

以上で設定は完了です。

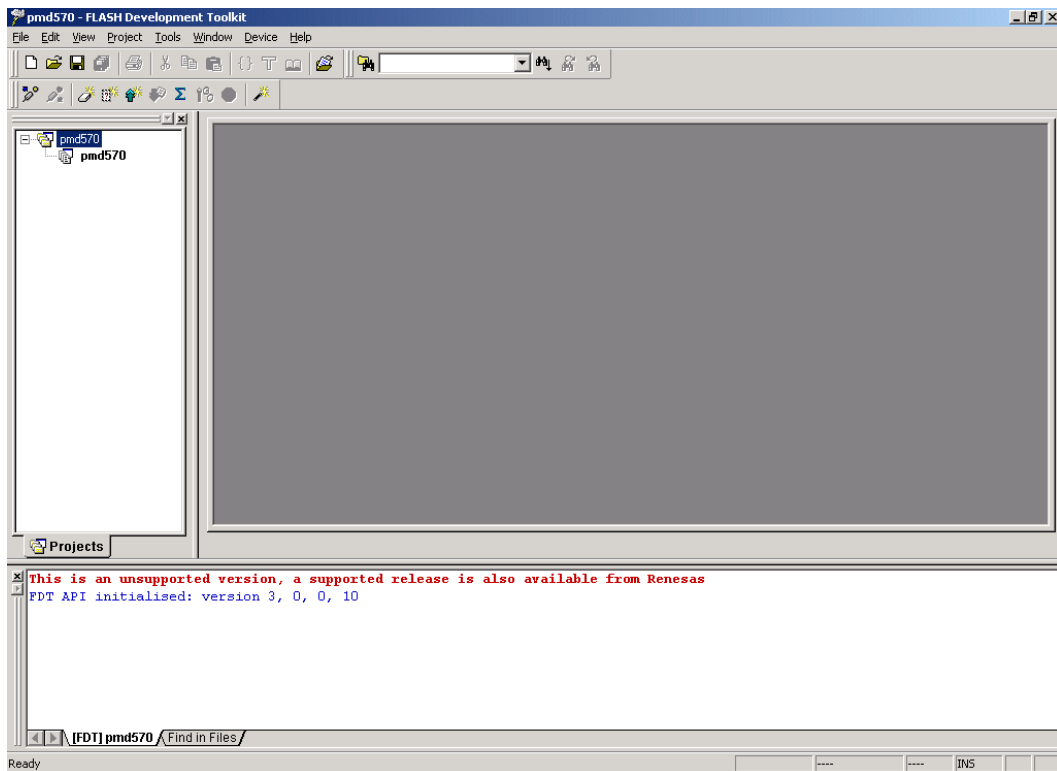

#### 4.4. Writing procedure

1. Click **Start / Programs / Renesas / Flash Development Toolkit3.0 / Flash Development Toolkit3.0**.
2. Click **OK**. (This window appears at every starting)

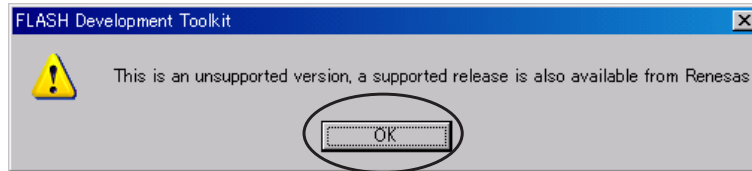

#### 4.4. 書き込み方法

1. **Start / Programs / Renesas / Flash Development Toolkit3.0 / Flash Development Toolkit3.0** をクリックします。
2. **OK** をクリックします。(起動のたびに下記のコマンドが出ますのでその都度 **OK** をクリックしてください)

3. Check **Open a recent project workspace**, and click **OK**.

3. **Open a recent project workspace**をにチェックを入れて **OK** をクリックします。

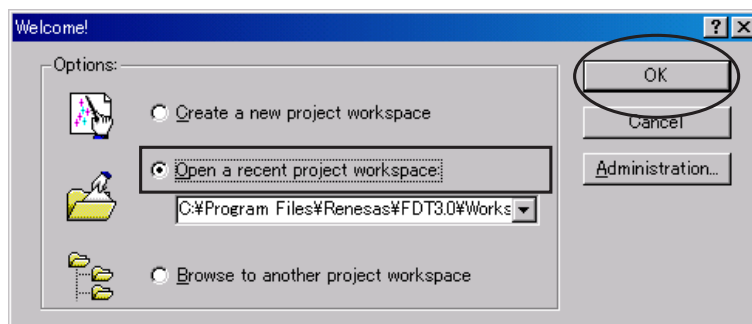

4. The right click **PMD570**, and Click **Add Files....**

4. 以下の画面が出ましたら、2階層目にある **PMD570** のアイコン上で右クリックをして、**Add Files...** をクリックします。

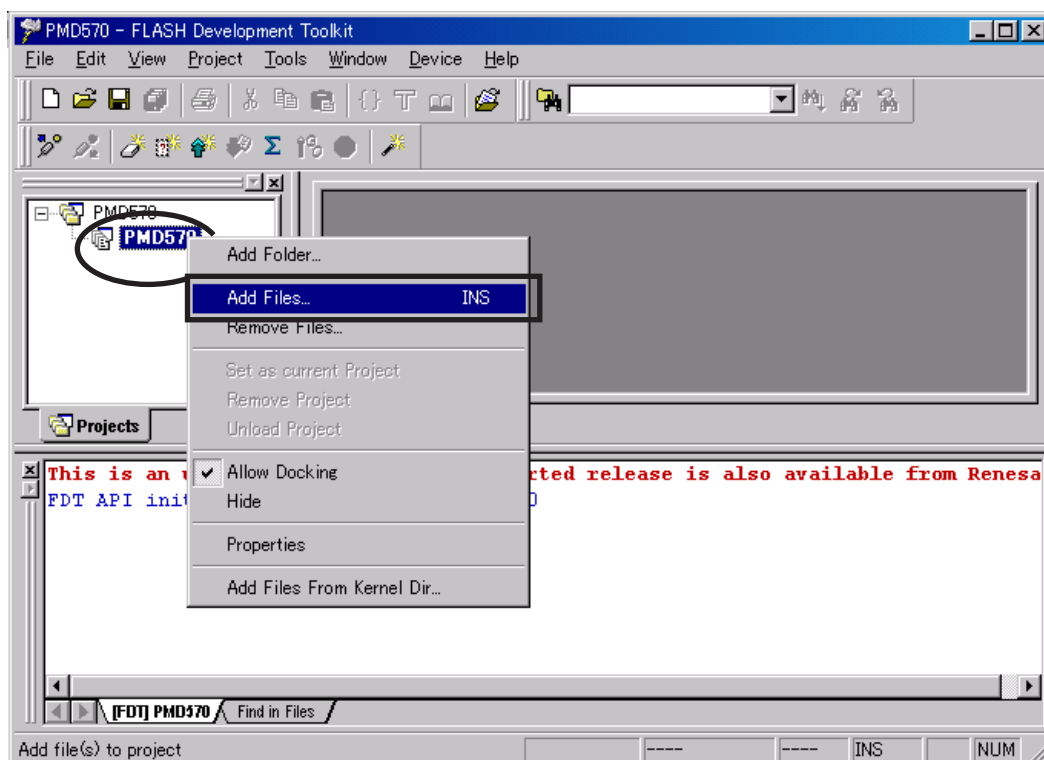

5. Open the CD-ROM (\*PMD570CDR Disc) and double click **soft** folder.      5. アップデートディスク (\*PMD570CDR) の **soft** フォルダをダブルクリックします。

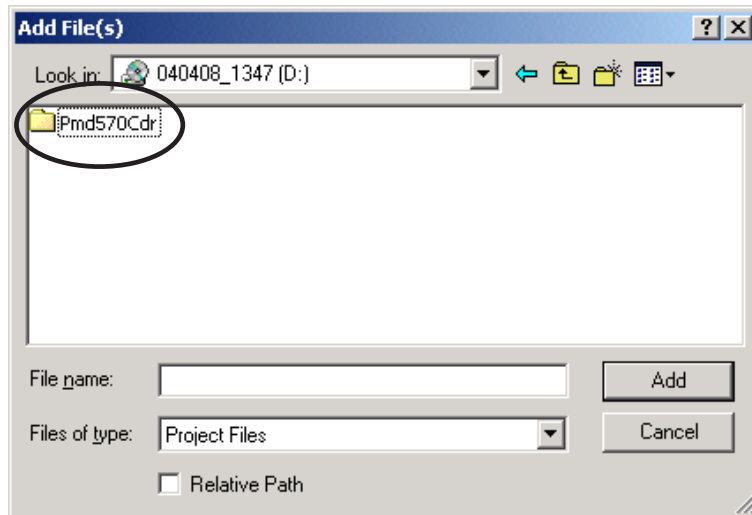

6. Select **PMD550.mot**, and Click **Add**.      6. **PMD550.mot** を選択し、**Add** をクリックします。

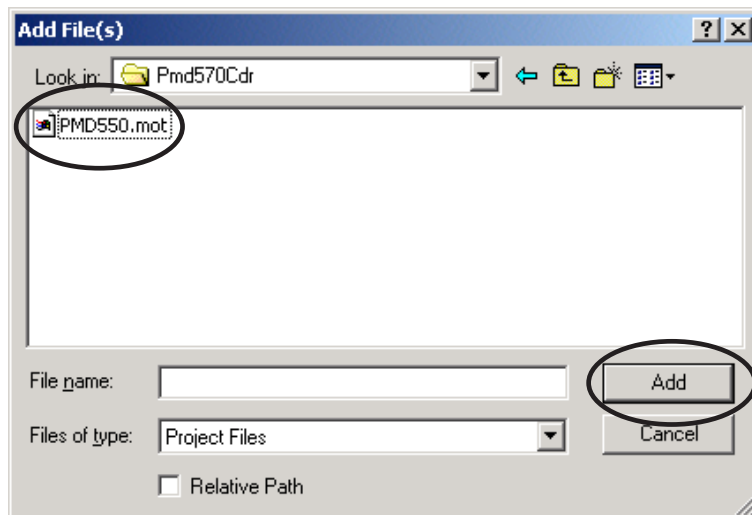

7. The holder of **PMD550.mot** is made.      7. **PMD550.mot** のホルダーが出来ます。

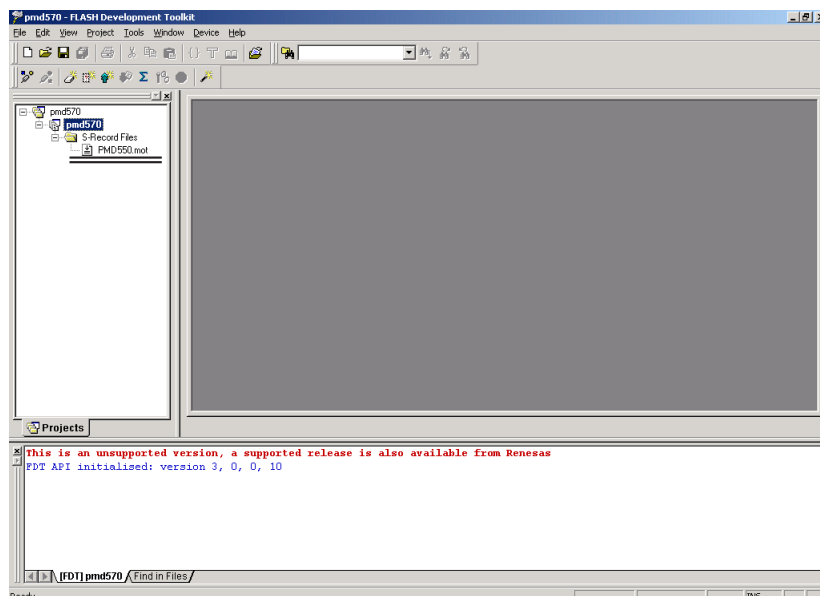



8. It checks that PMD570 and the COM port are connected by RS232C cable.
9. Insert a thin rod to the hole and push the switch inside to turn on the switch.

PMD570 Rear Panel

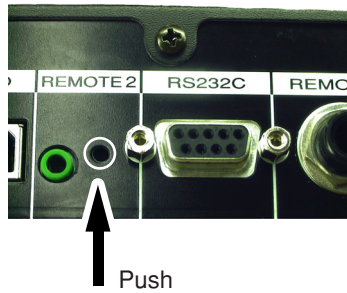

8. PMD570とWindows PCのCOMポートの接続を確認します。
9. リアパネルのREMOTE 2 端子の横にある内部スイッチをONします。

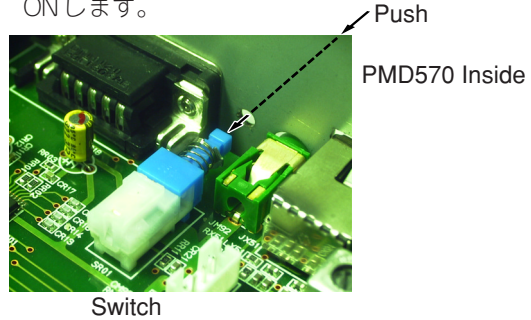

10. Press **POWER** Button to turn on the unit.  
The unit is in the boot mode. (LED and LCD display on the front panel disappear.)

10. **POWER** ボタンを押し、Power On 状態にします。  
(この状態より、書き込みモードですが、前面のLED及びLCD表示は消えます。)

11. The right click PMD550.mot, and Click **Download File**.

- 11.4階層目にある PMD550.mot のアイコン上で右クリックをして “**Download File**” をクリックします。

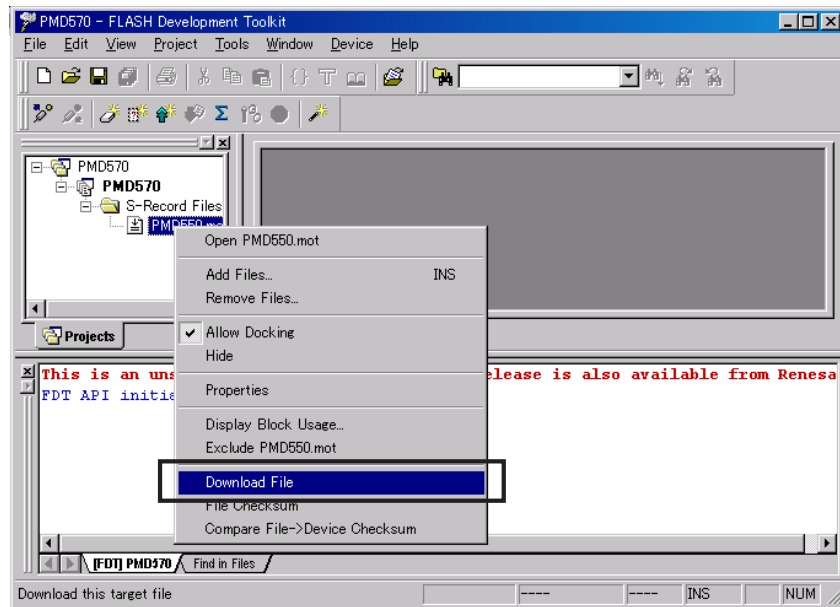

12. The screen becomes the uploading condition.  
When writing is finished, the below message appears on the screen.

12. 書き込みが始まると下のような画面が出て状態を表示します。  
書き込みが終わると下のような画面が出ます。

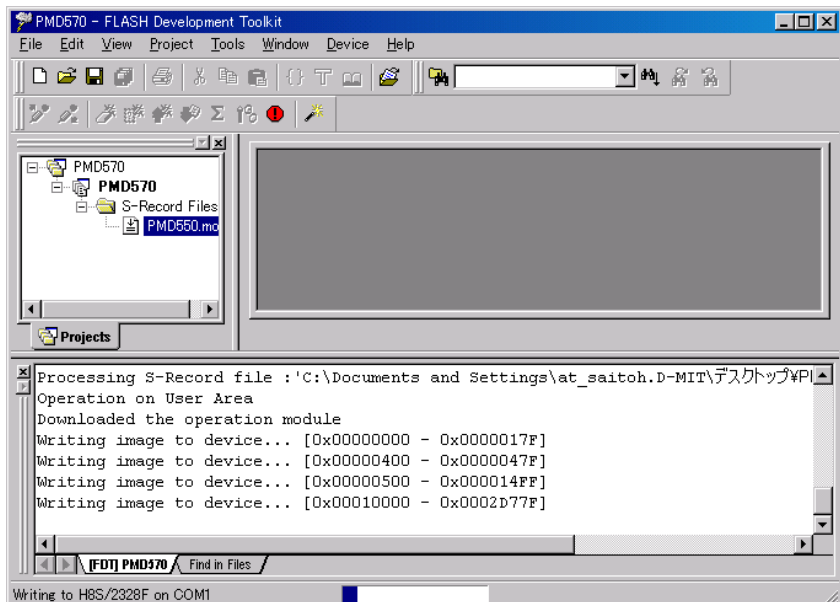

13. The Main microprocessor (QU01) has been Update.

13.以上で、書き込み作業は終了です。

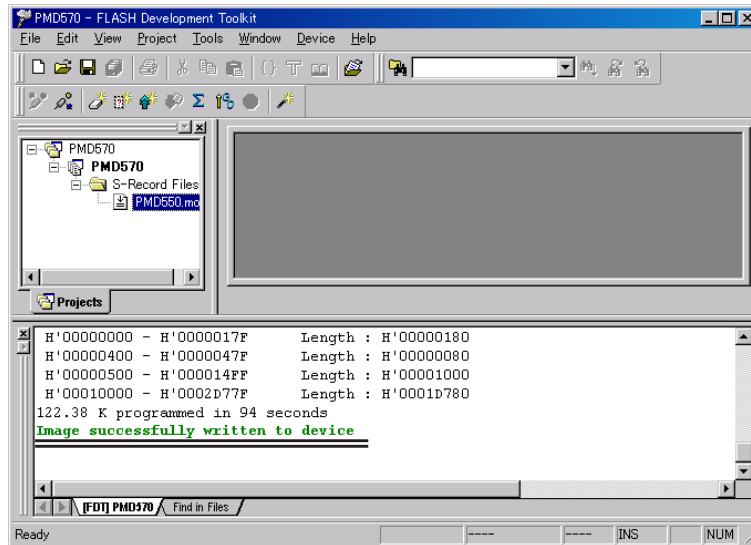

14. Turn off the **internal switch** that has been turned on at step 9.

14.リアパネルのREMOTE 2 端子の横にある内部スイッチを OFF します。

**NOTICE:**

When the internal switch is not turned off, the set becomes the mode of update of firmware every time to turn on the unit.

**注意**

この操作をしないと PMD570 の電源を入れた時、毎回書き込みモードになります。

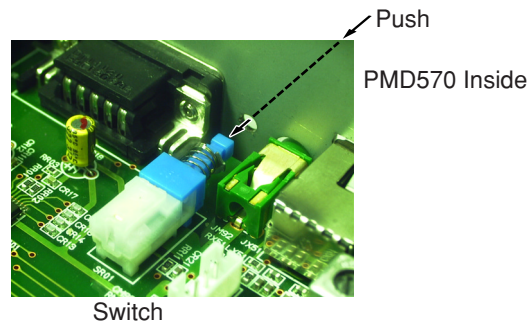
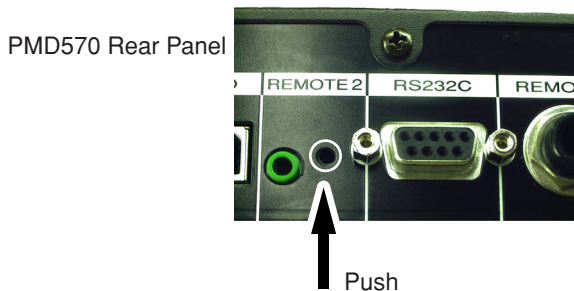

15. Turn off Power switch, then disconnect RS232C cable from PMD570.

15.PMD570 の電源を切り、RS232C ケーブルを外します。

16. Check the version number of the firmware  
Refer to 2-page "2. SERVICE MODE" for "2.1. Micro-Processor Version check" confirmation.

16.VERSION の確認をします。

2 ページ "2. SERVICE モードの 2.1. VERSION 確認" で確認します。  
書き込んだ、バージョンが正しければ書き換え完了です。

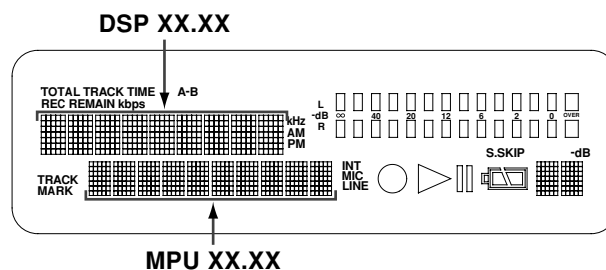

#### 4.5. FACTORY MODE

After the completion of update of Main microprocessor (QU01), to reset all setting to default status, follow the procedure below.

##### /N version

1. Press the **POWER** button while pressing **MENU/STORE** and **◀◀ (REW)** button. (**MENU/STORE** and **◀◀ (REW)** button are pushed 3 seconds or more.)
2. **FACTORY** name is displayed on LCD. The unit becomes the setup of default automatically.

##### /F and /U version

1. Press the **POWER** button while pressing **MENU/STORE** and **▶▶ (FWD)** button. (**MENU/STORE** and **▶▶ (FWD)** button are pushed 3 seconds or more.)
2. **FACTORY** name is displayed on LCD. The unit becomes the setup of default automatically.

#### 4.5. FACTORY モード

ソフトのバージョンアップをした際には、仕向け別に出荷設定(EEPROMの初期化)を行ないます。

##### /N 仕向け

1. **MENU/STORE** ボタンと **◀◀ (REW)** ボタンを押しながら **POWER** ボタンを押します。3秒以上ボタンを押します。
2. **FACTORY** と表示がでます。自動的に出荷時の設定になります。

##### /F と /U 仕向け

1. **MENU/STORE** ボタンと **▶▶ (FWD)** ボタンを押しながら **POWER** ボタンを押します。3秒以上ボタンを押します。
2. **FACTORY** と表示がでます。自動的に出荷時の設定になります。

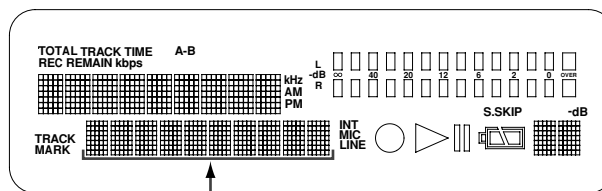

### Factory

処理中は、Factory と表示されます。完了したら、通常表示となります。  
Displayed as "Factory" during processing. And display returns after complete.

#### 4.6. The procedure of upload firmware two or more Units continuously

1. Click **Disconnect**.

#### 4.6. 書き込みを複数台連続で行なうときは ...

1. "Disconnect" をクリックして、未接続状態にします

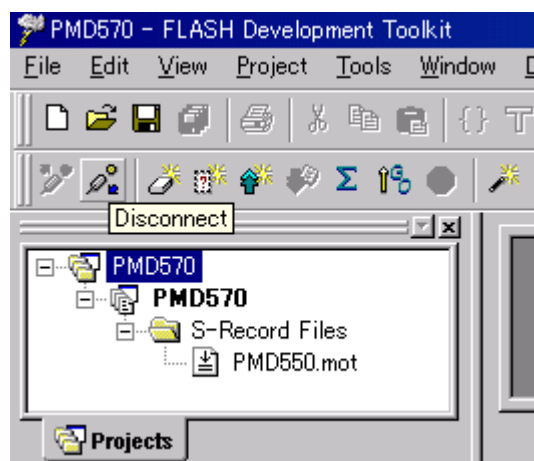

2. Replace the unit with a new one and connect RS-232C cable to the set.

2. 新しいセットに入れ替え、Windows PC とケーブルにて接続します。

3. Insert a thin rot to the hole and push the switch inside to turn on the switch.

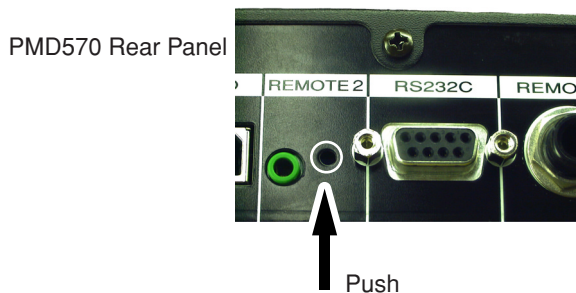

3. リアパネルのREMOTE 2 端子の横にある内部スイッチを ON します。

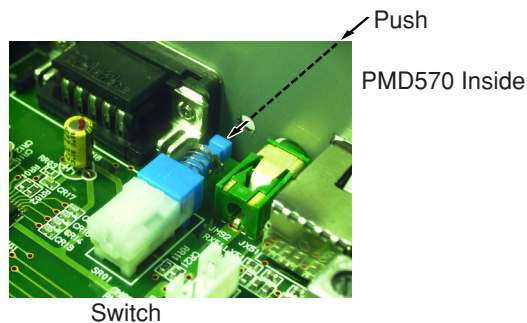

4. Press **POWER** Button to turn on the unit.  
The unit is in the boot mode.( LED and LCD display on the front panel disappear.)

4. **POWER** ボタンを押し、Power On 状態にします。  
(この状態より、書き込みモードですが、前面のLED及びLCD表示は消えます。)

5. Click **Connect**.

5. “**Connect**” をクリックして、接続状態にします

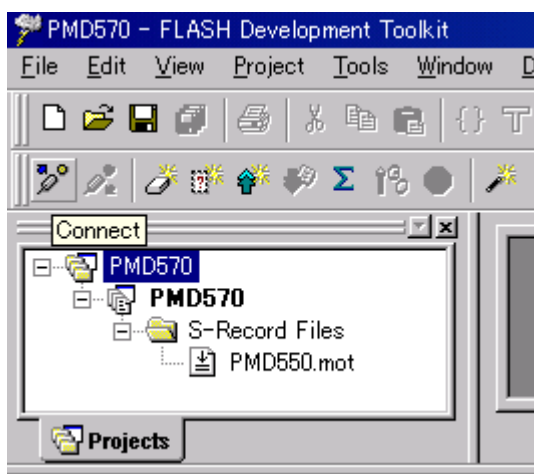

6. The right click PMD570, and Click **Download File**.

6. 4階層目にある PMD550.mot のアイコン上で右クリックをして “**Download File**” をクリックします。

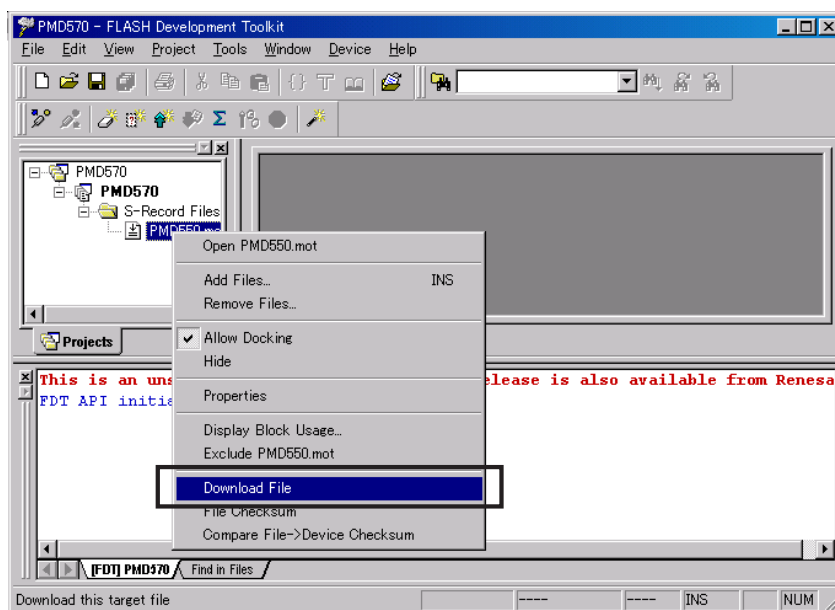

7. After this procedure, continues to step 12.

7. 以降は4.4. 書き込み方法の手順12から引き続いてを行ないます。

# 5. WIRING DIAGRAM

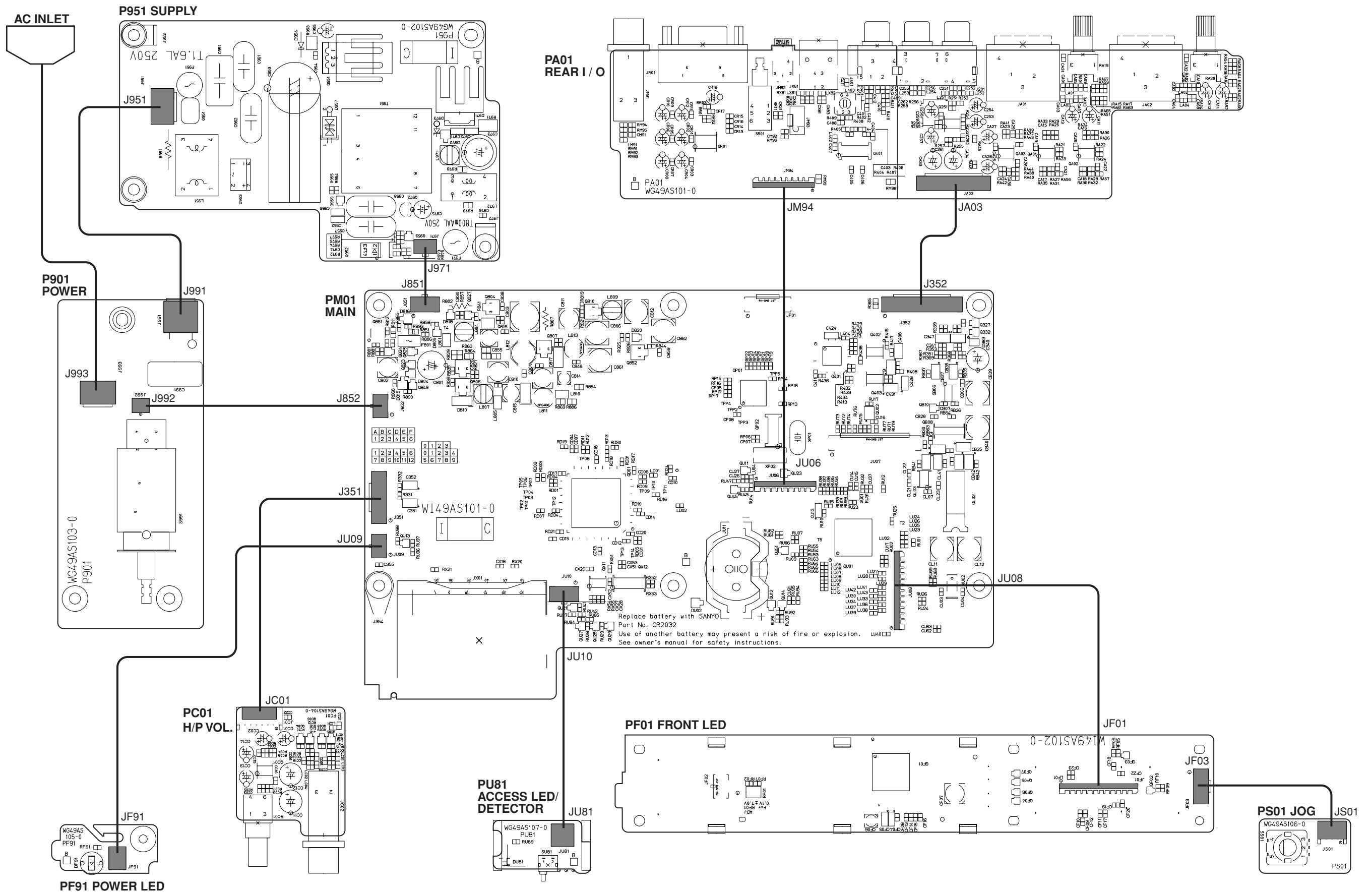

## 6. BLOCK DIAGRAM

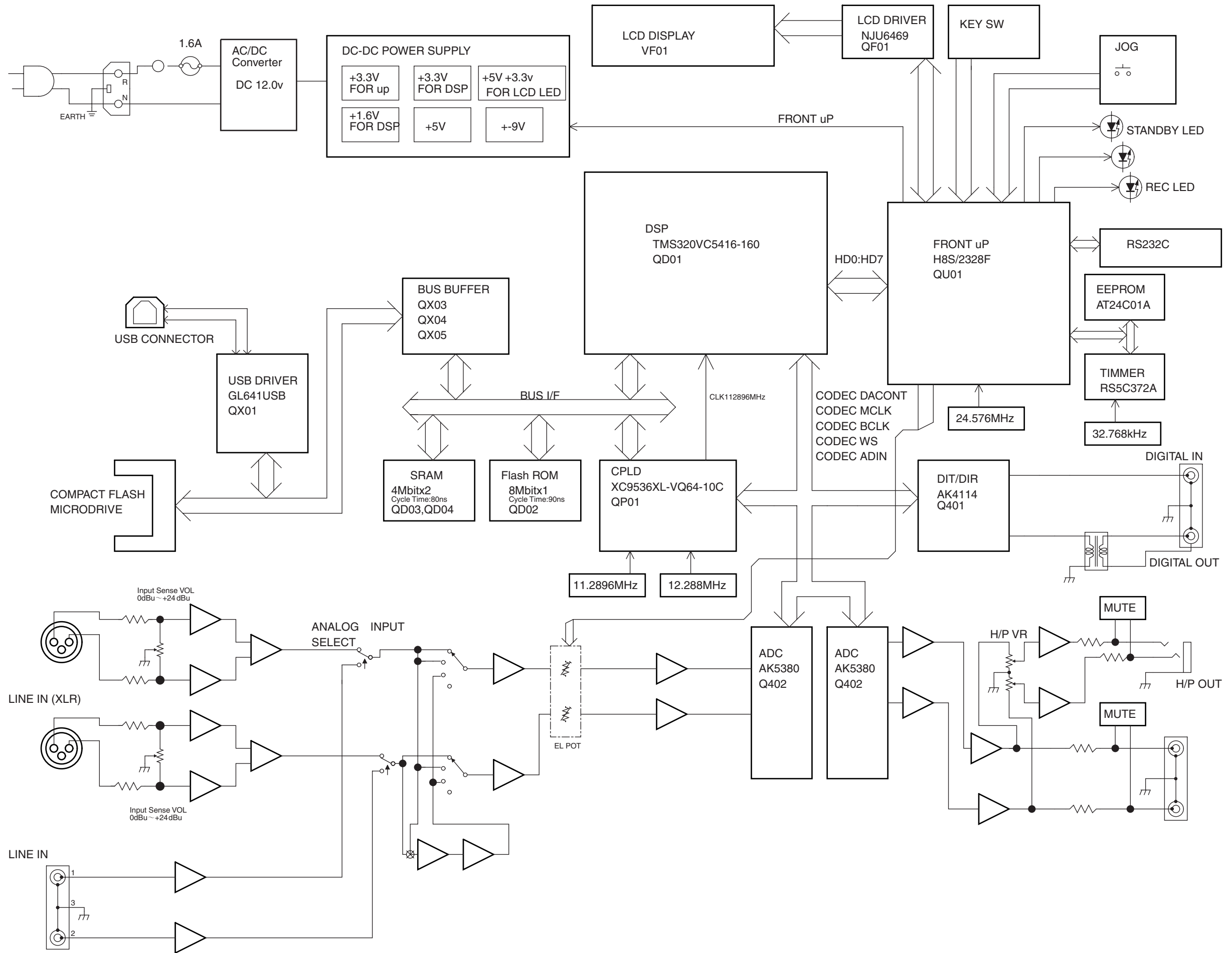

# 7. SCHEMATIC DIAGRAM

## PM01-1/9 MAIN PCB

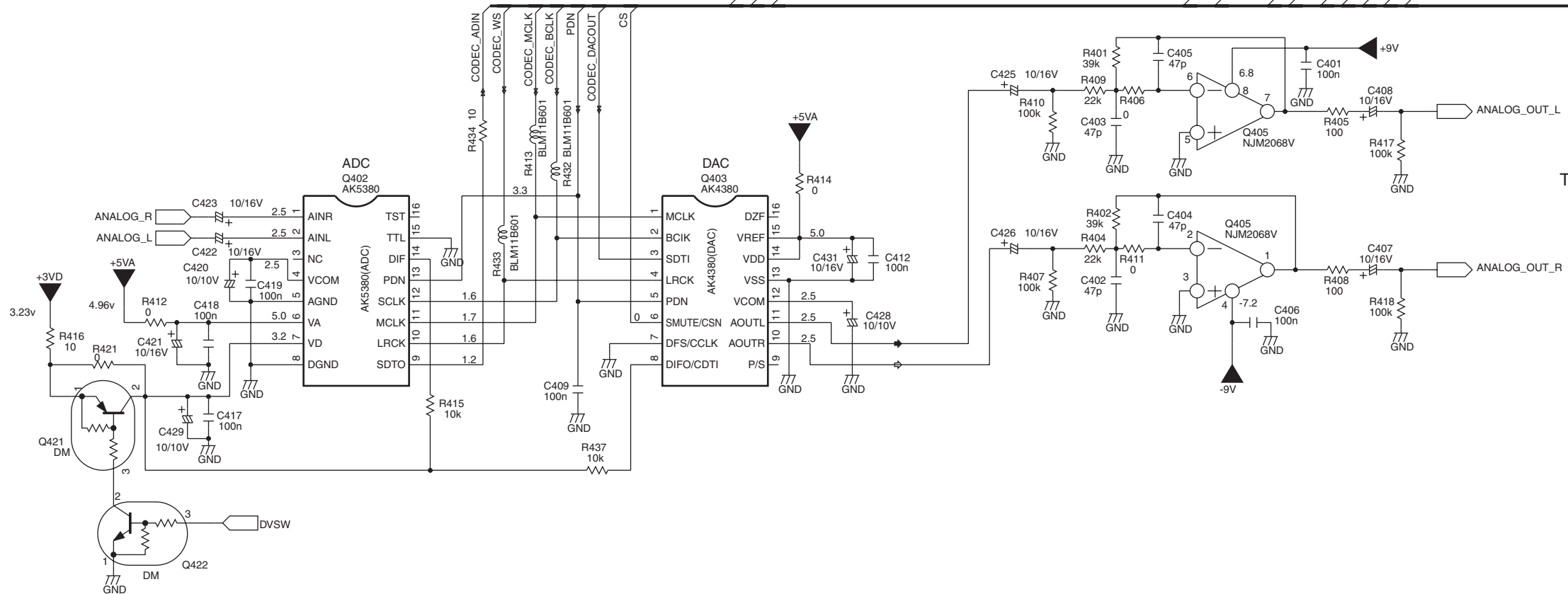
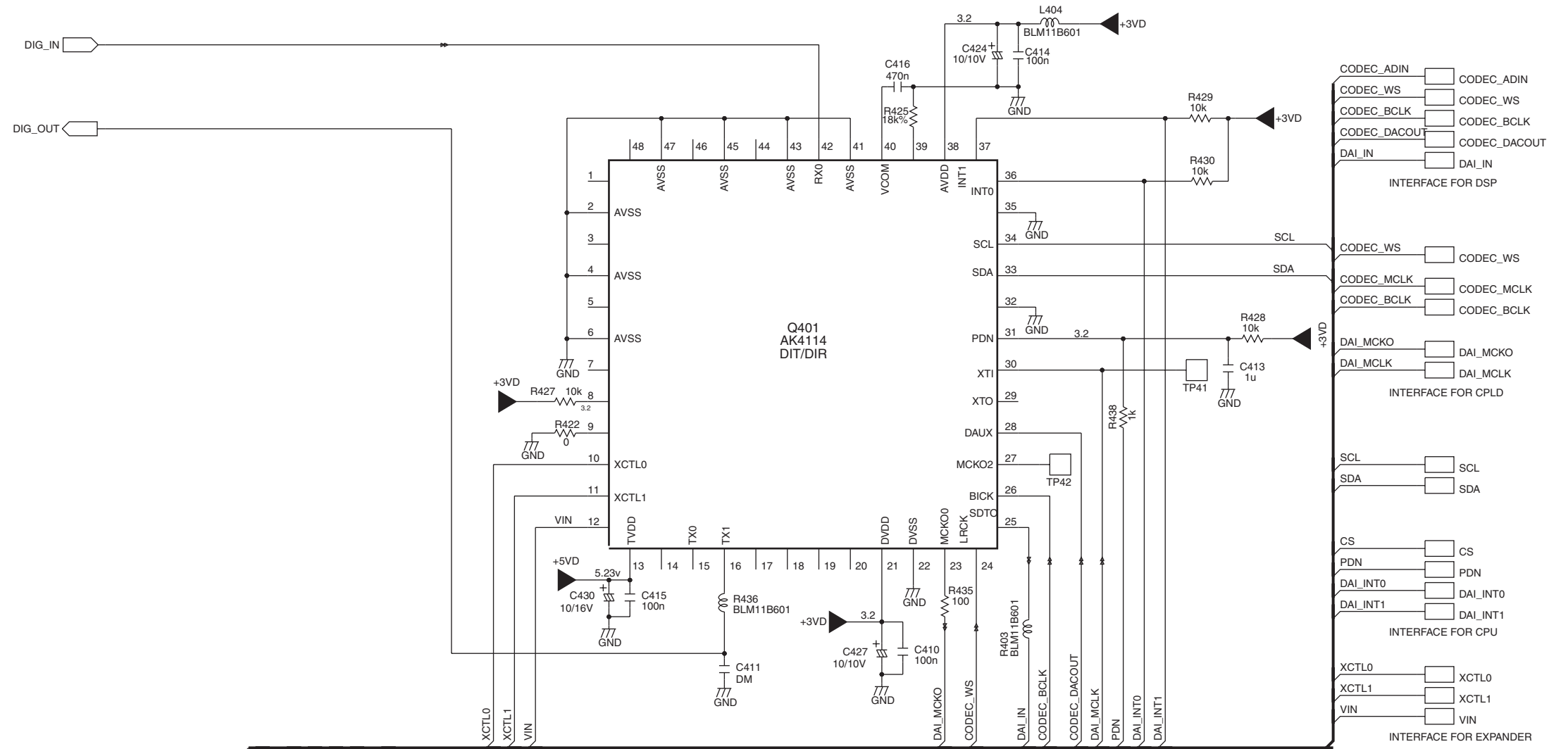

TO PM01 9/9

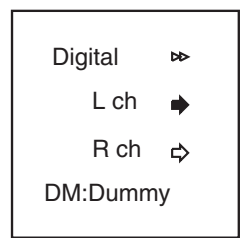

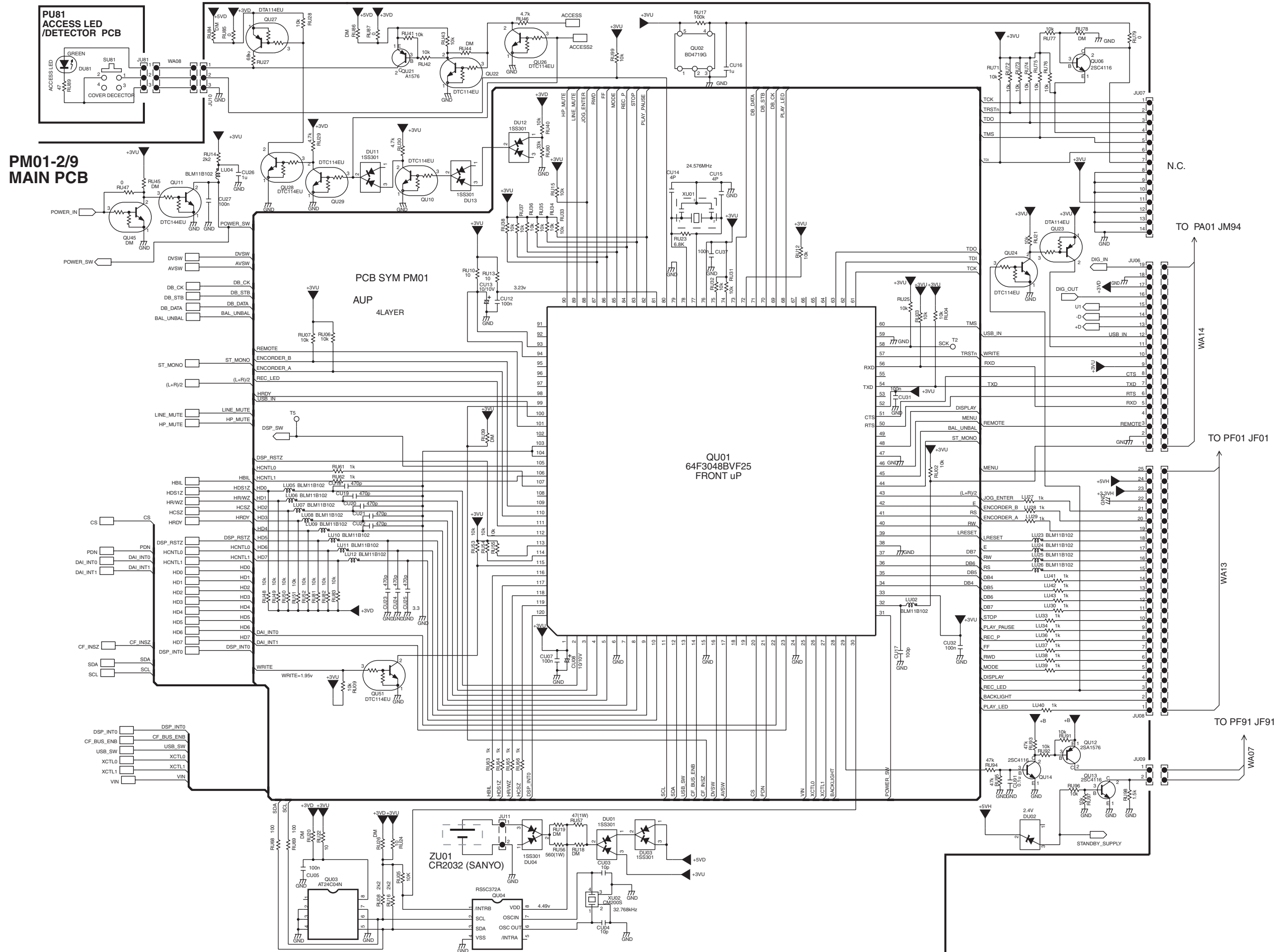



**PM01-3/9  
MAIN PCB**

PCB SYM PM01  
4LAYER  
AUB

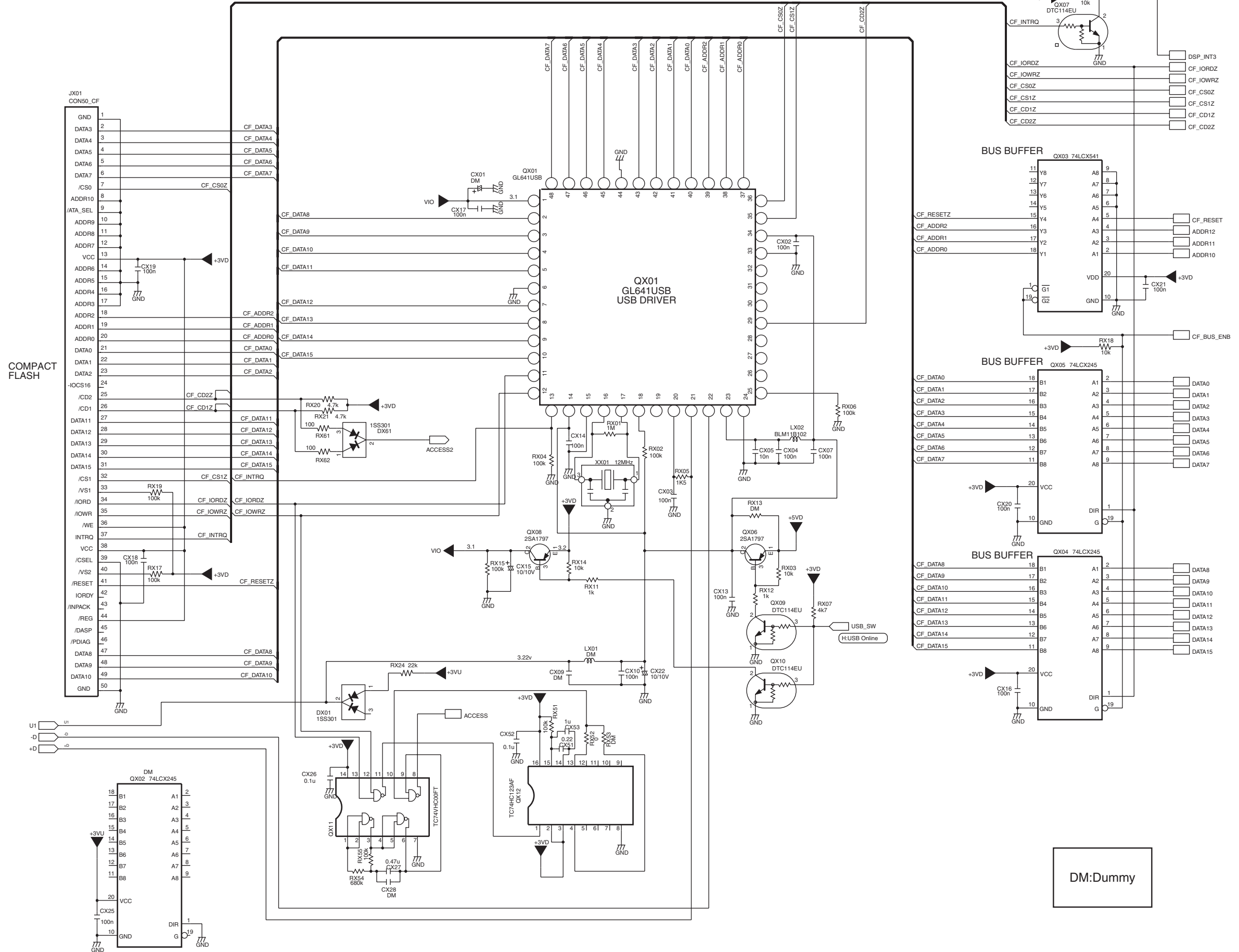

COMPACT FLASH

DM:Dummy

PM01-4/9  
MAIN PCB

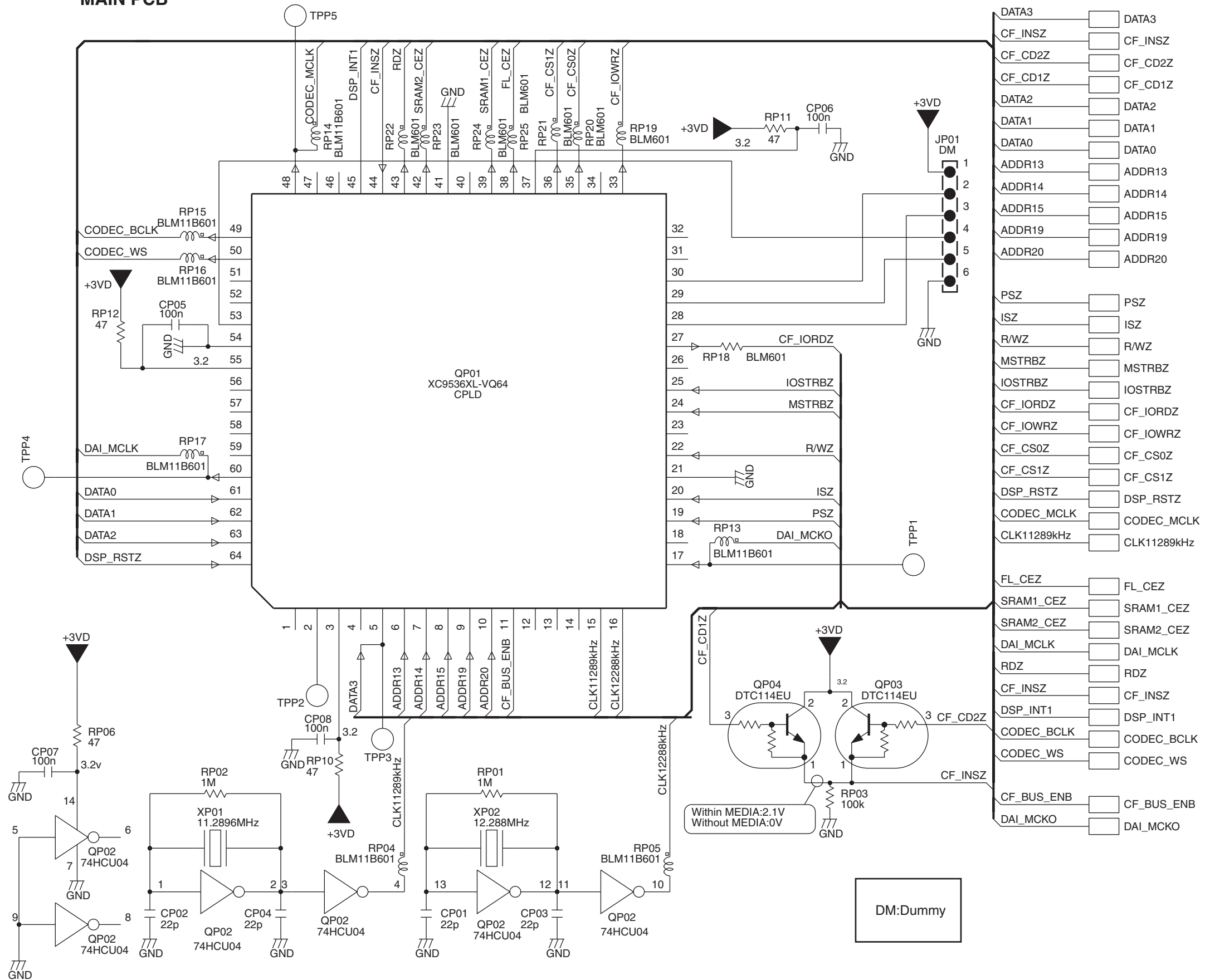

PM01-5/9  
MAIN PCB

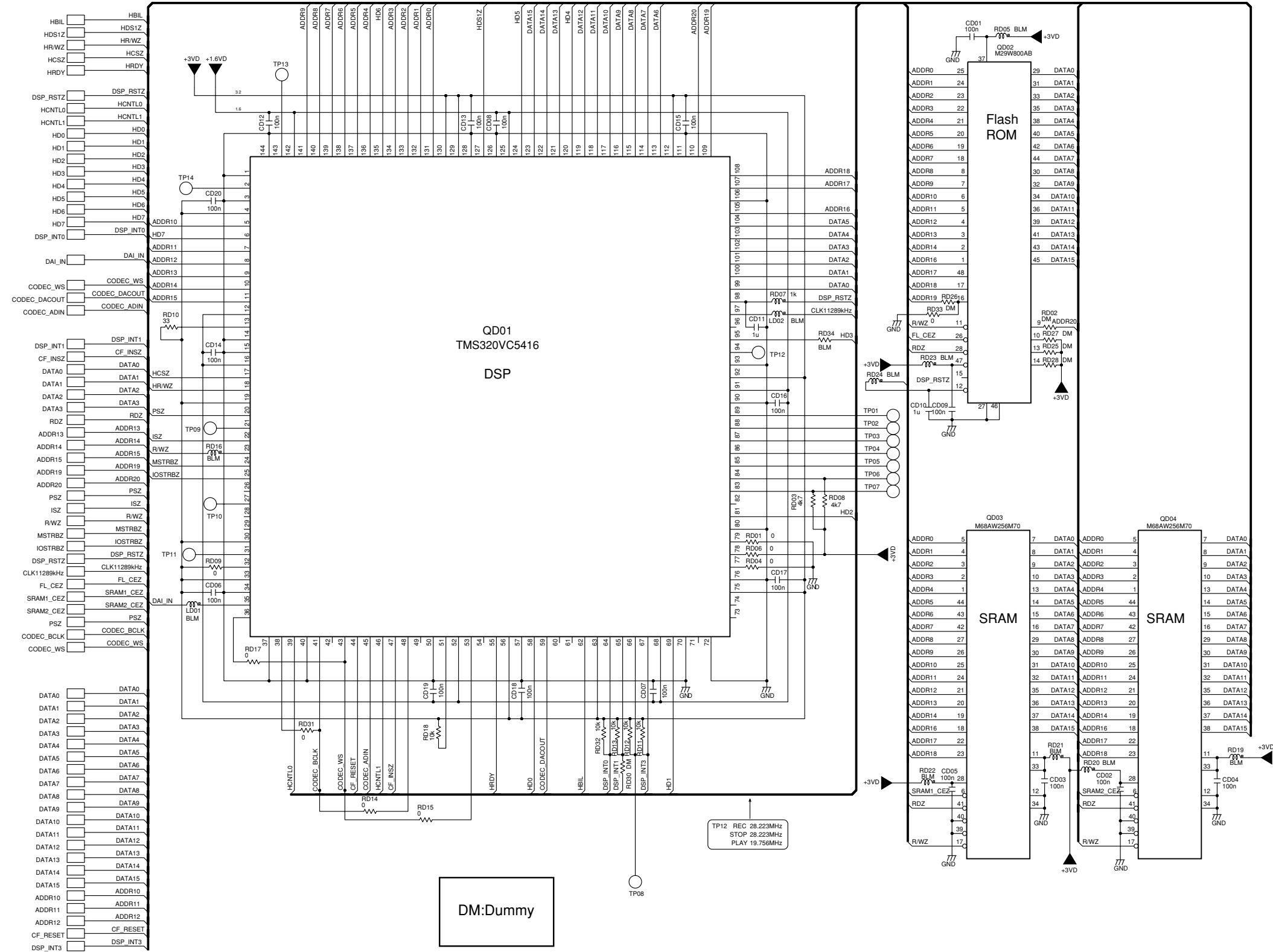

**PM01-6/9  
MAIN PCB**

FROM P951 J971

FROM P951 J992

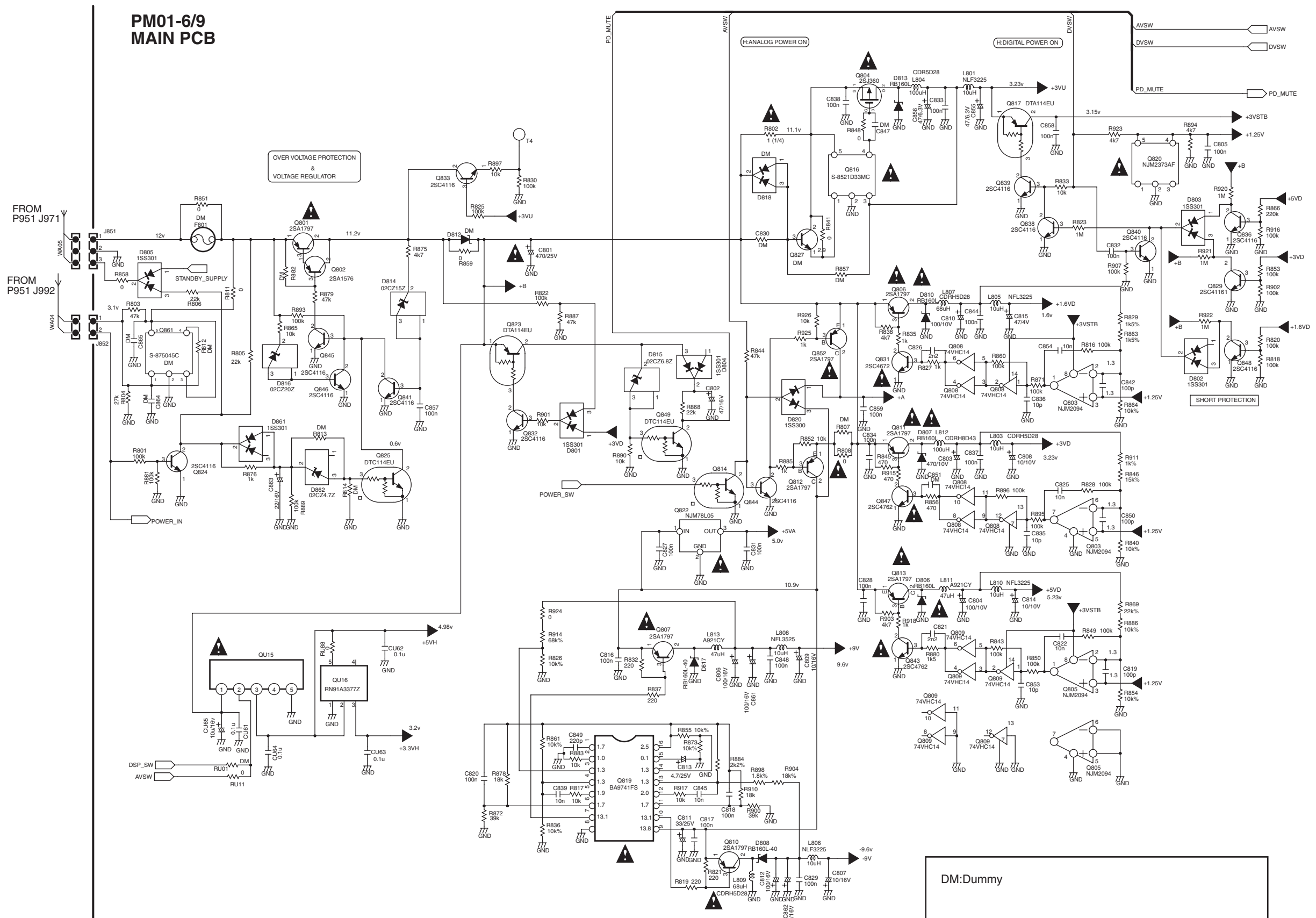

DM: Dummy

"NOTE ON SAFETY: The parts marked with  are IMPORTANT PARTS on the safety. Please use the parts having the designated parts number without fail.

**PM01-7/9  
MAIN PCB**

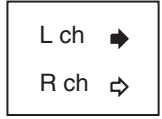
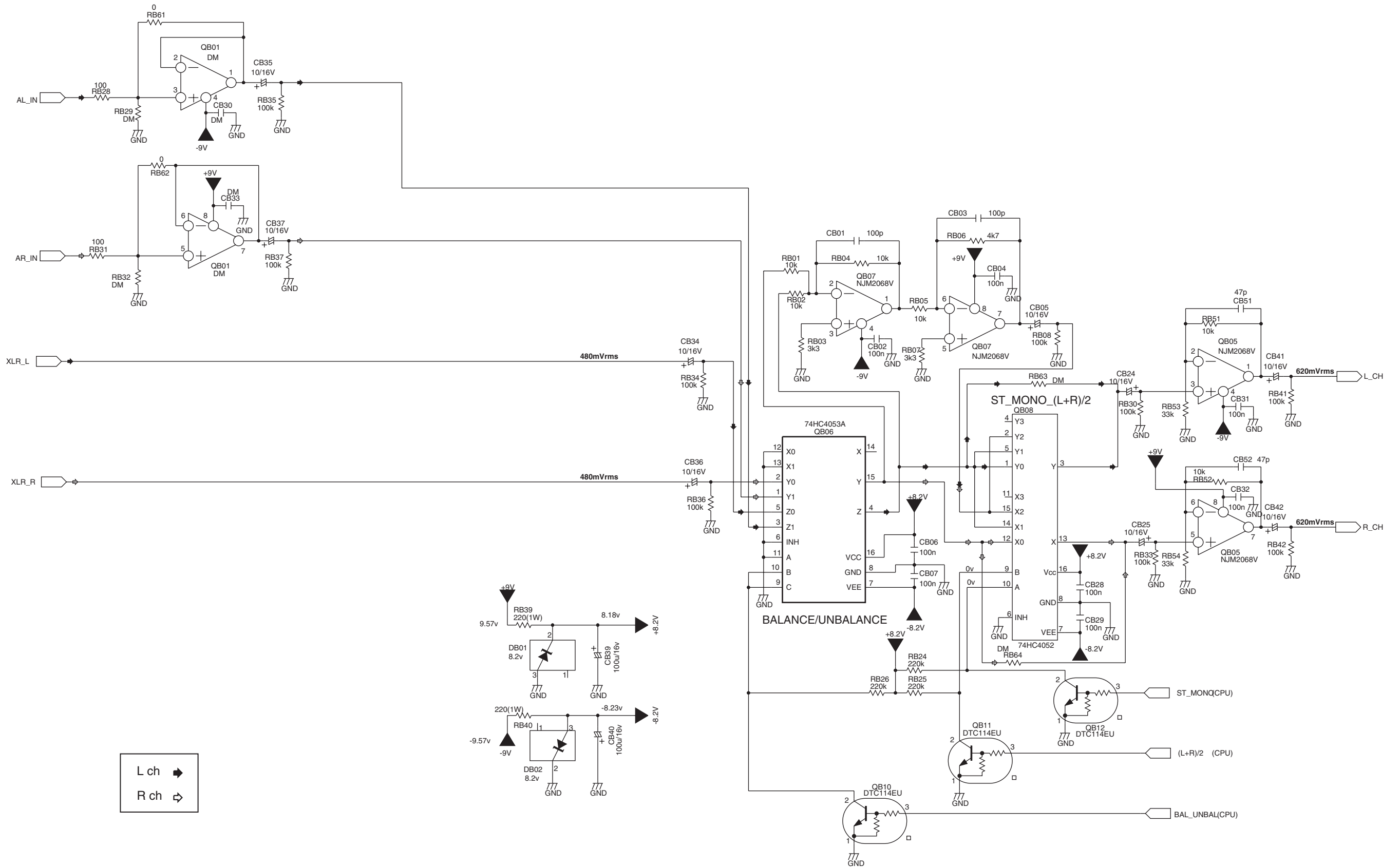

**PM01-8/9  
MAIN PCB**

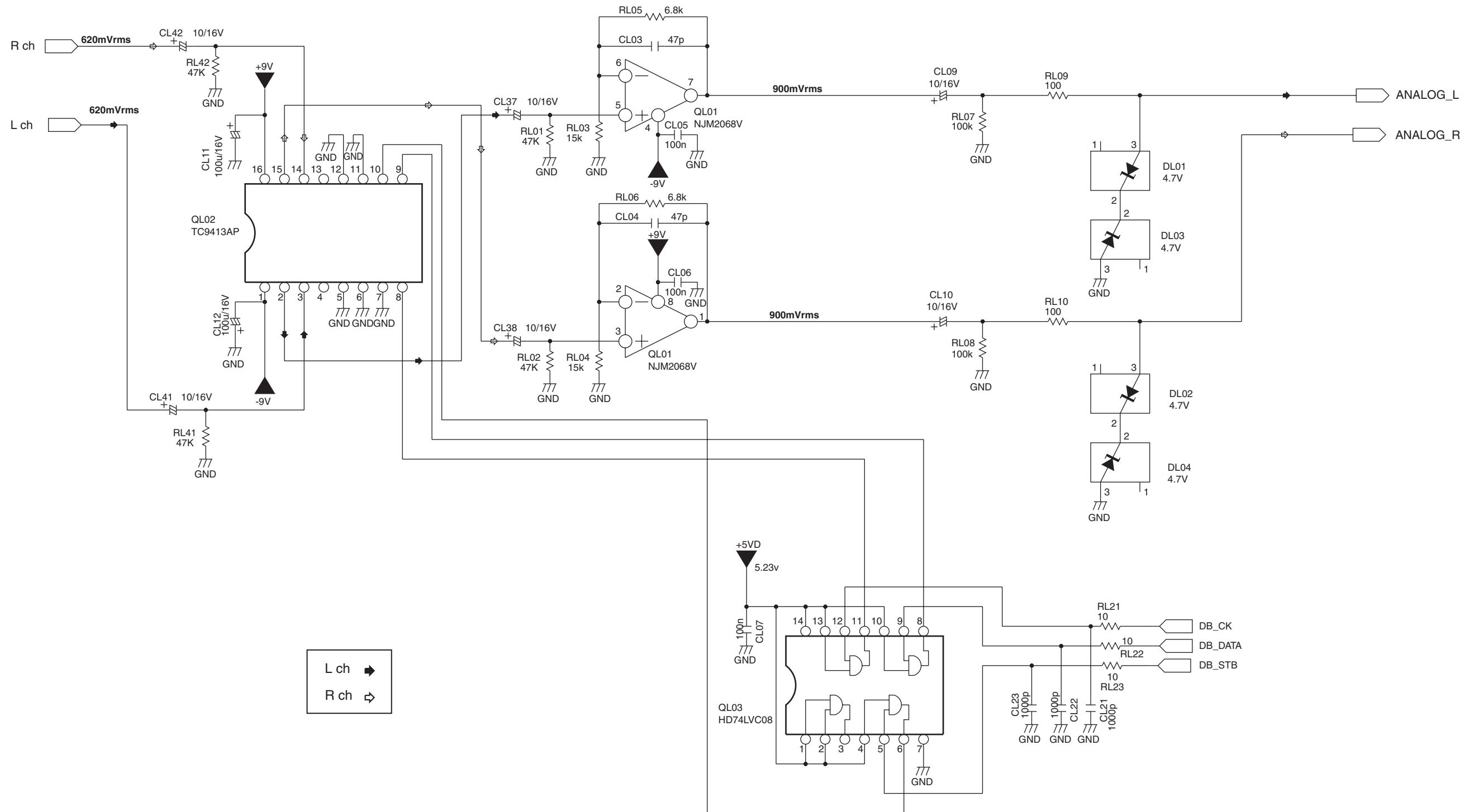

L ch →  
R ch ↺

**PM01-9/9  
MAIN PCB**

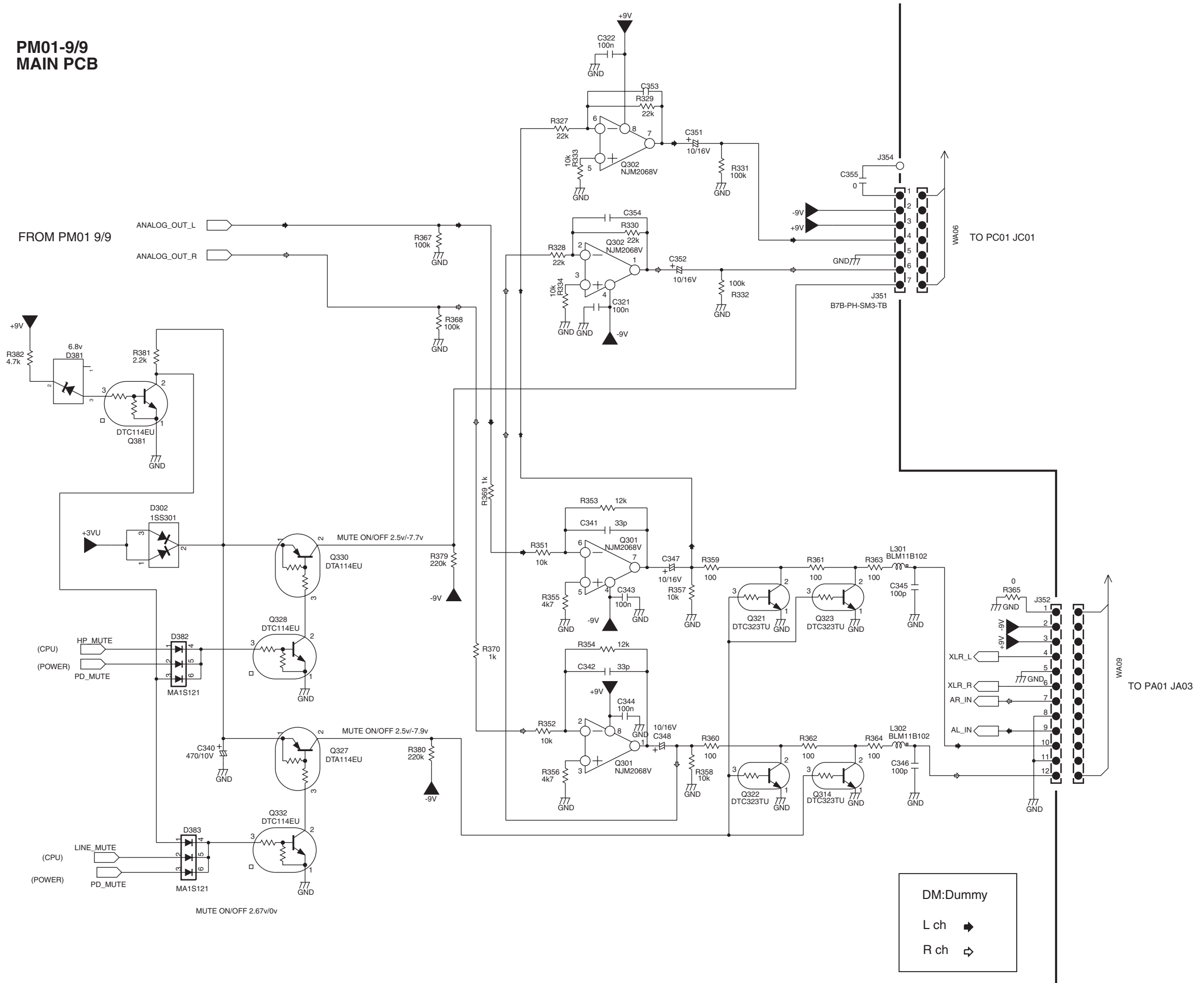

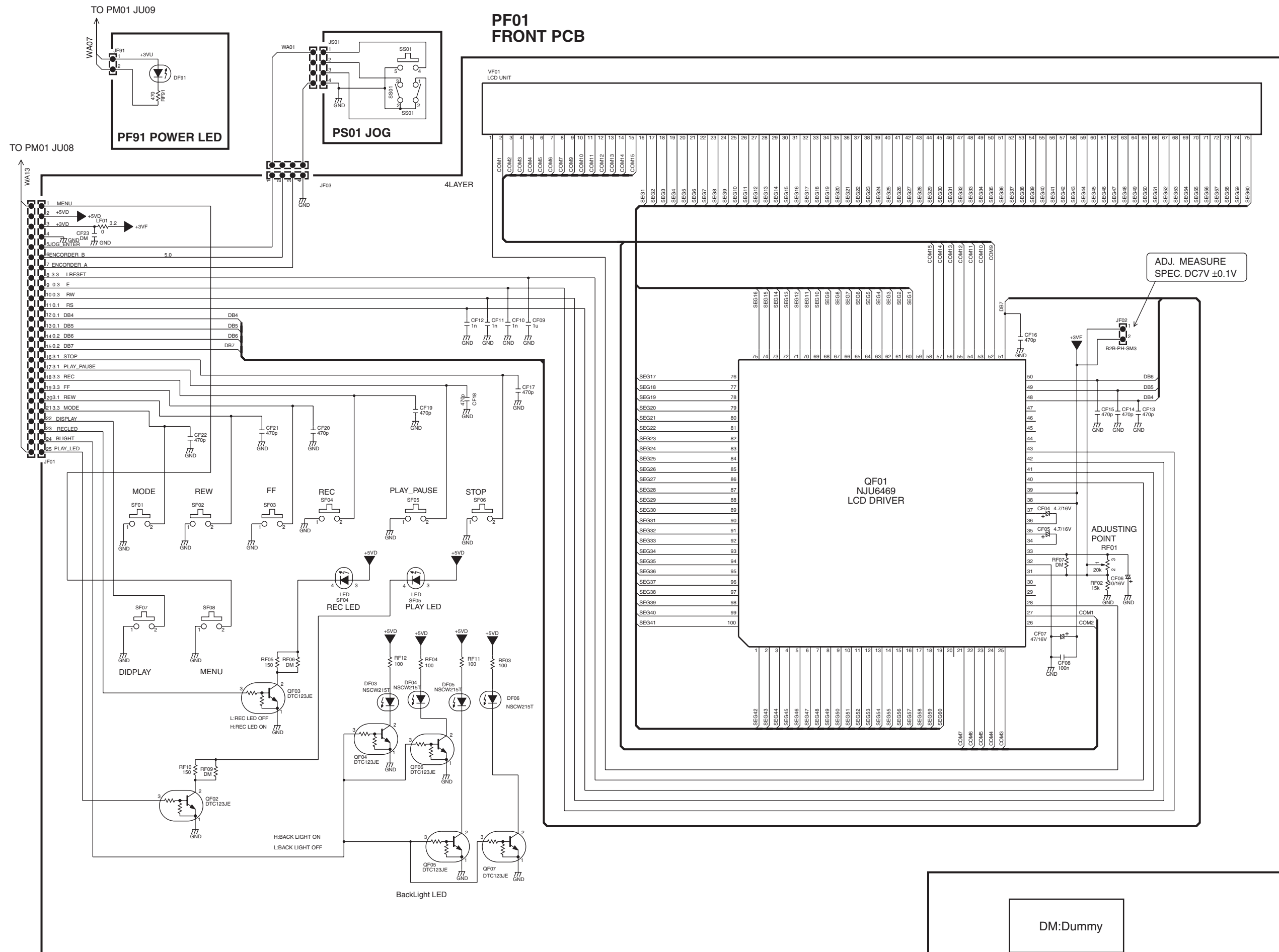

DM:Dummy



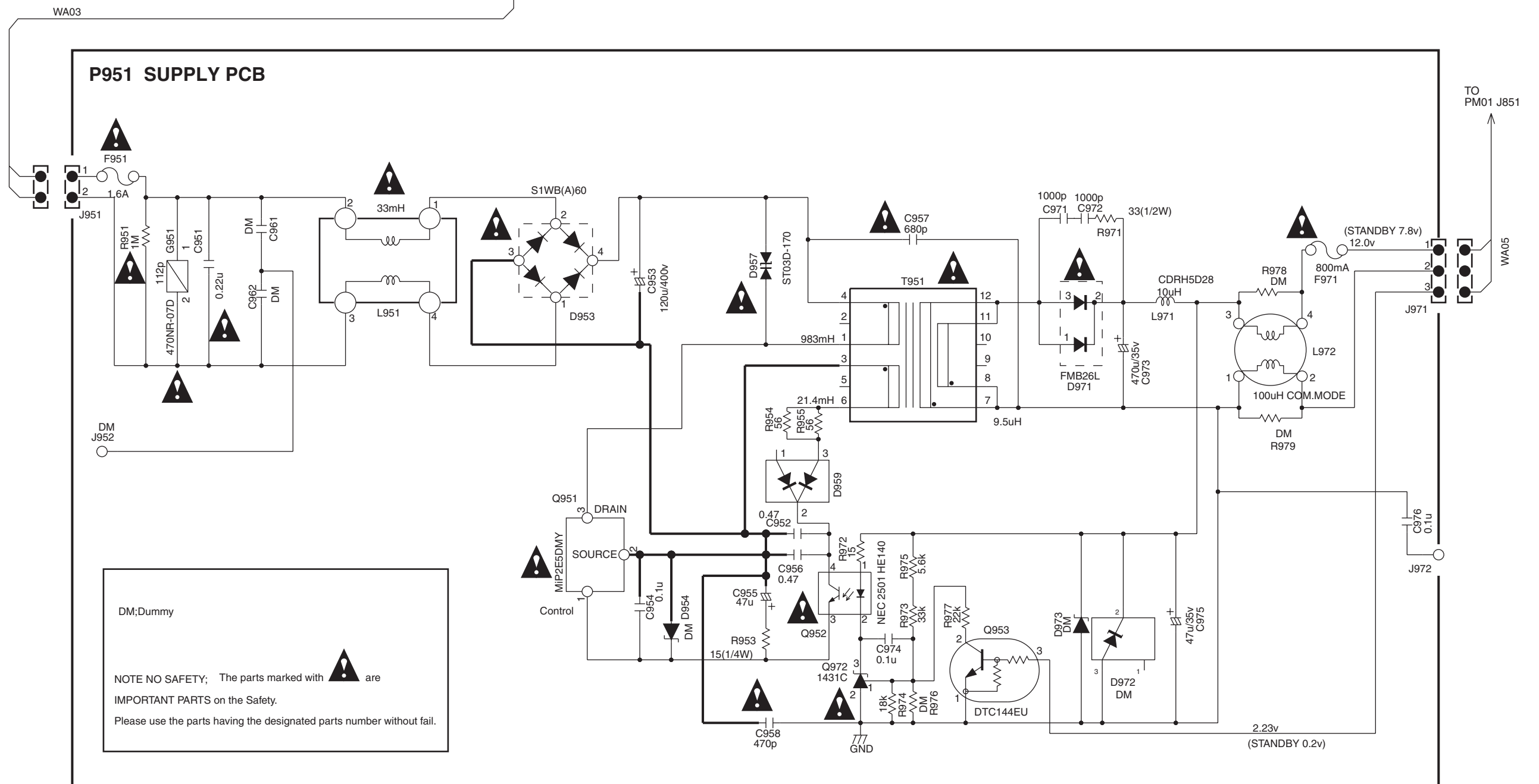
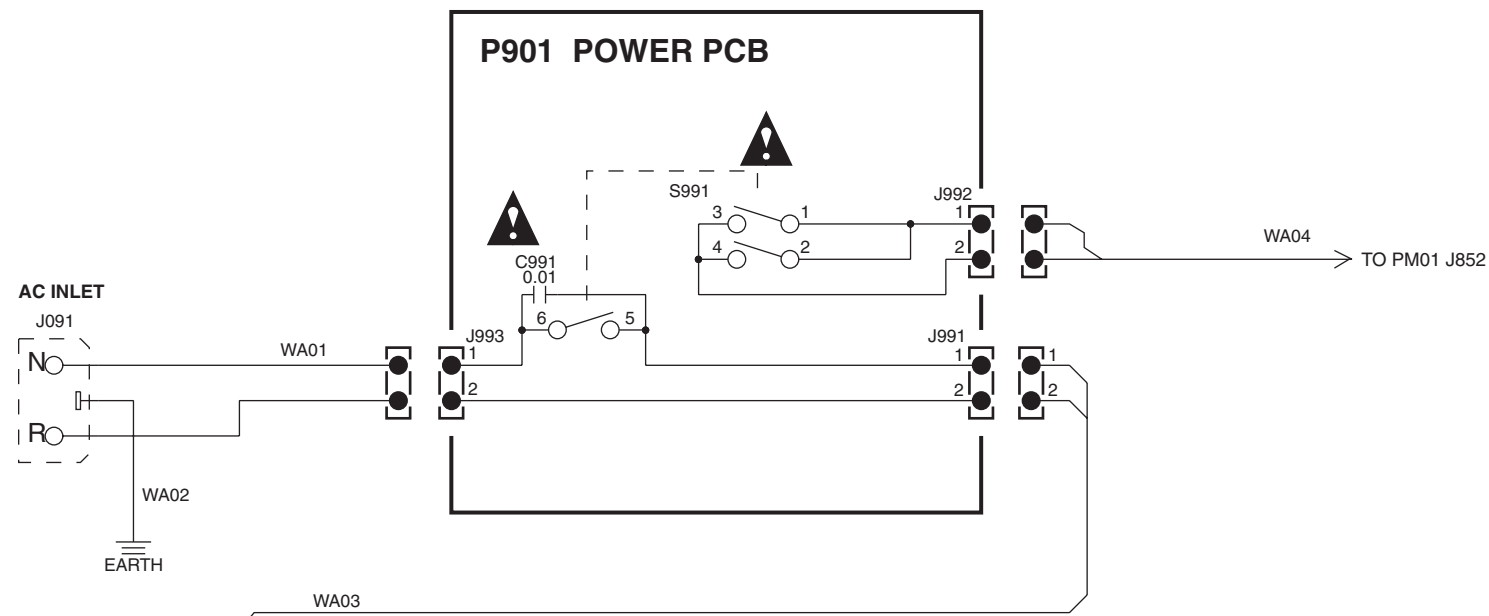

DM; Dummy

NOTE NO SAFETY; The parts marked with  are IMPORTANT PARTS on the Safety. Please use the parts having the designated parts number without fail.

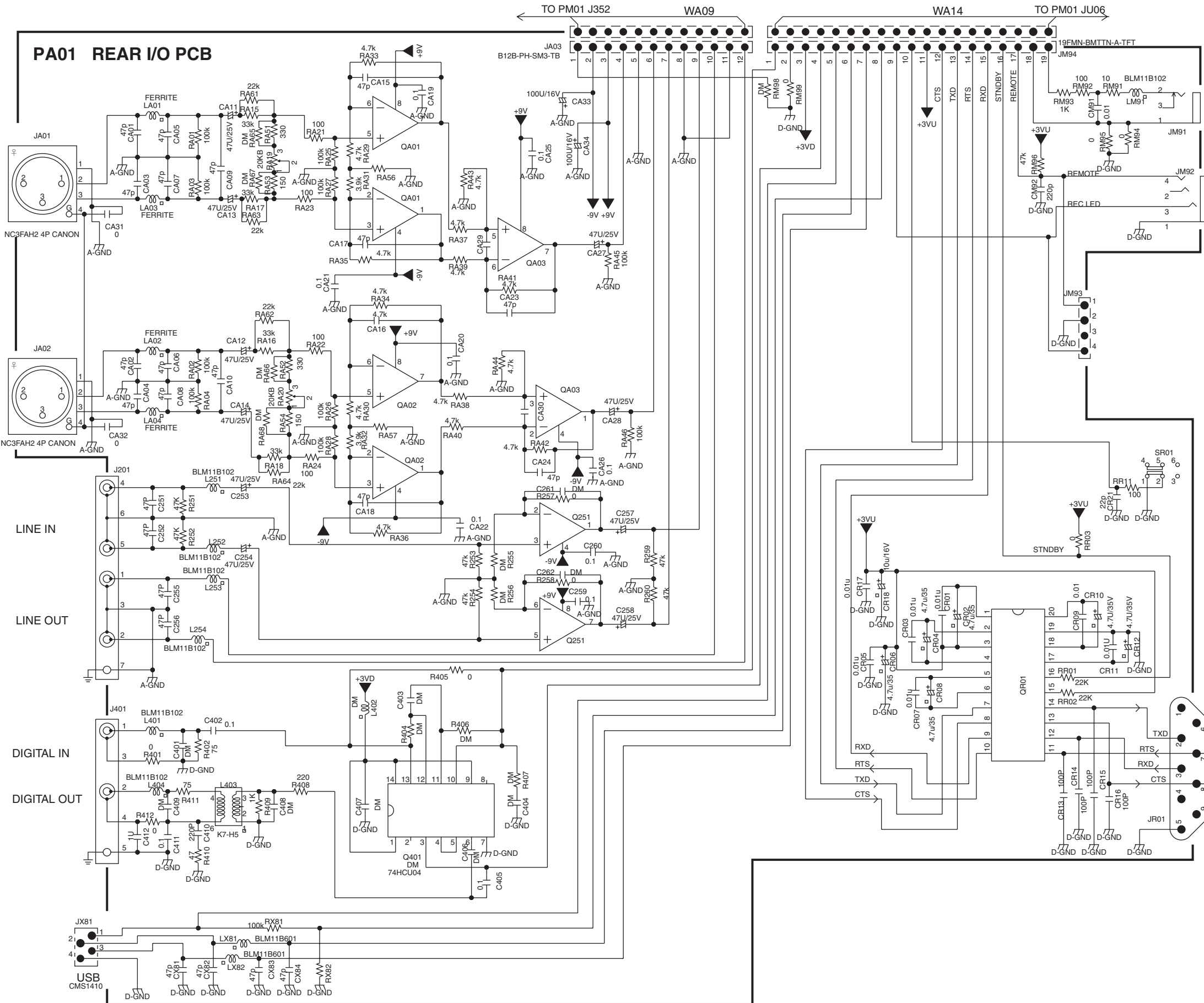

PC01 H/P VOL. PCB

FROM PM01 J351

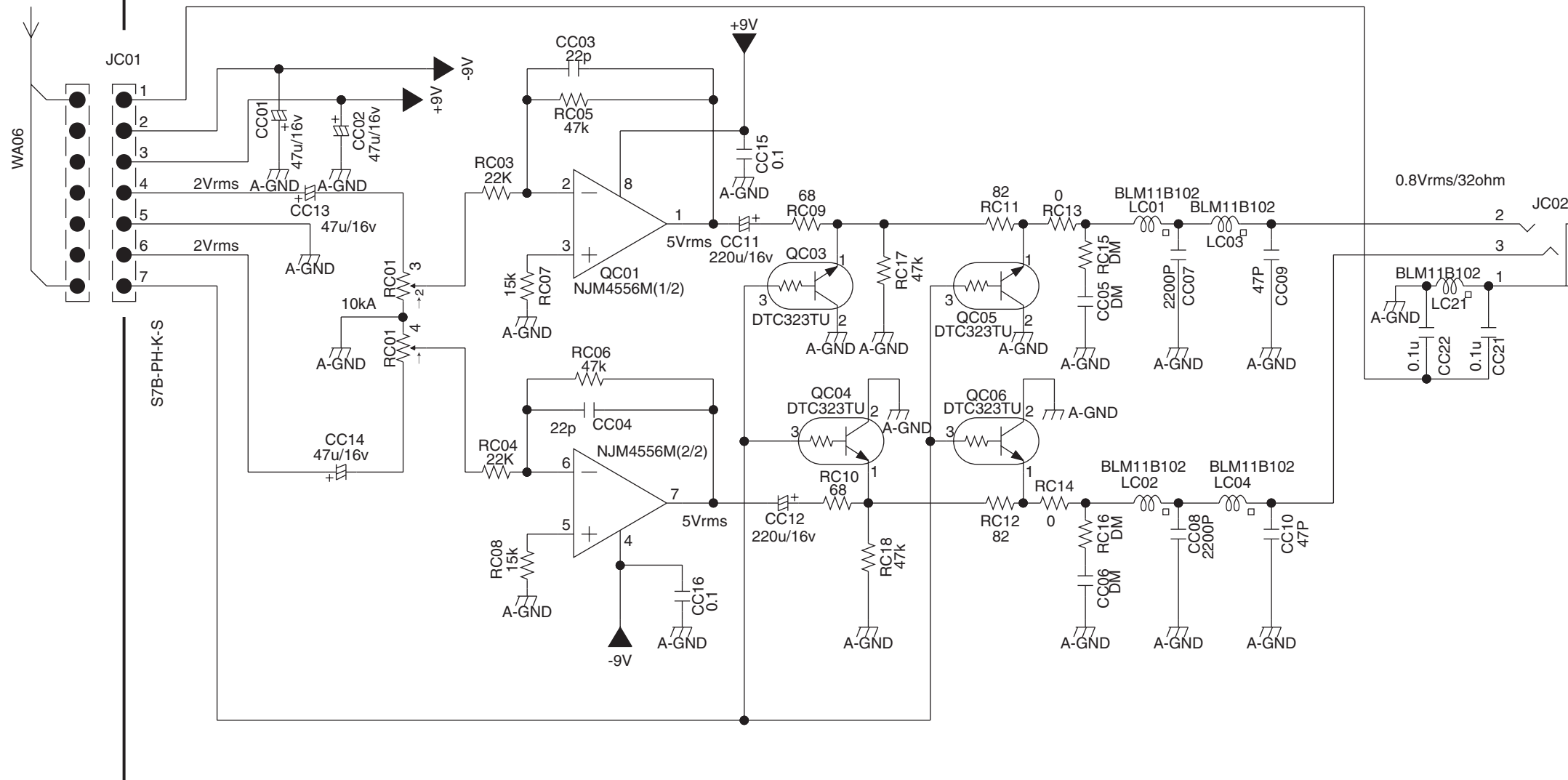

# 8. PARTS LOCATION

Q861 Q825 Q827 Q804 Q810 Q402 Q327  
 Q824 Q831 Q816 Q807 Q852 QP01 Q401 Q403 QB08 QB10 QB06 Q332  
 Q823 Q849 Q806 QD01 QX11 QX12 QU45 QU11 QP02 QU23 QU01 QU02 QL03 QL02  
 QU13 QU21 QU27 QU28 QU29

PM01 A

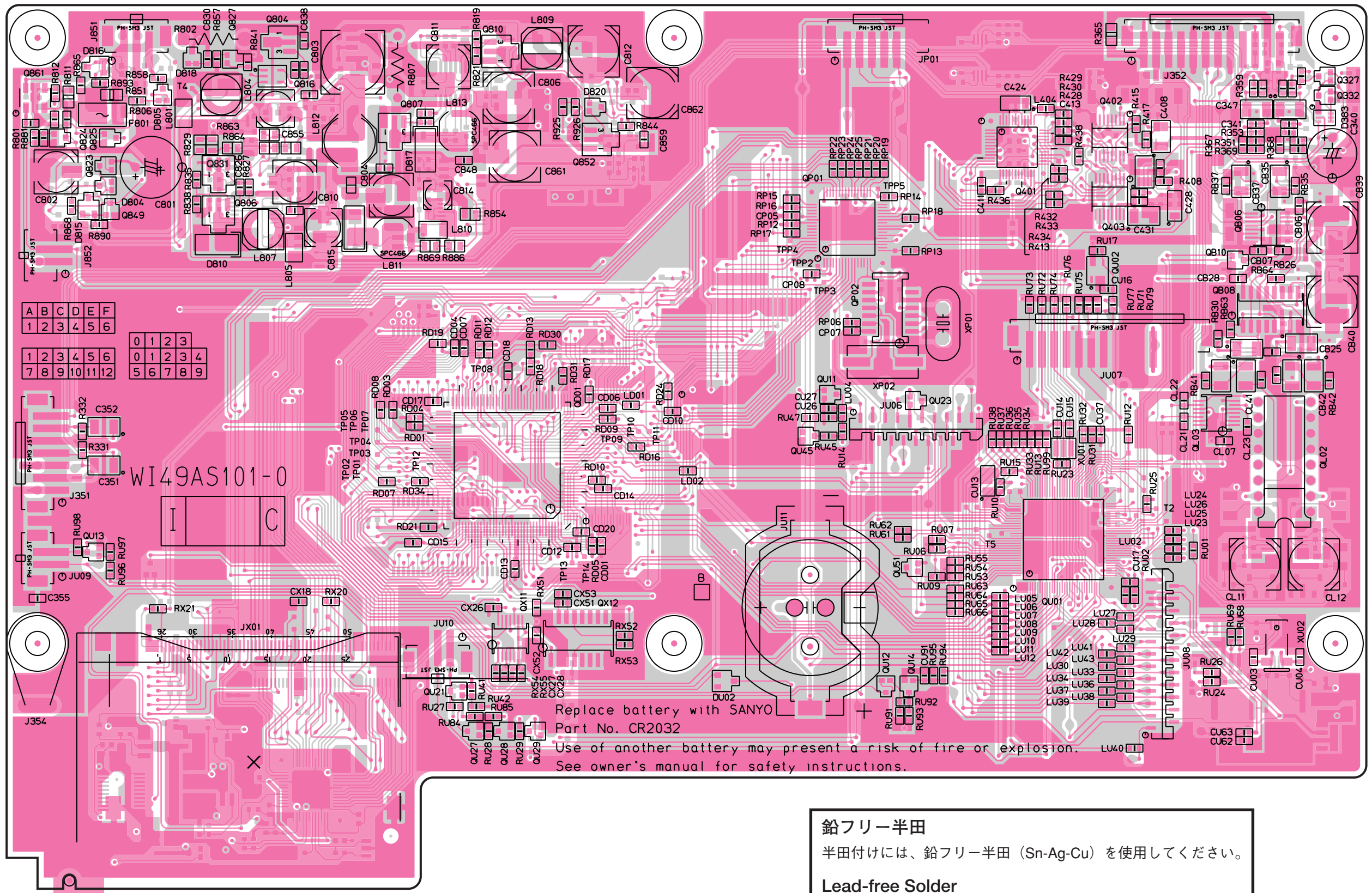

Q330 Q328 Q314 Q322 Q321 Q323 Q302 Q819 Q812 Q814 Q820 Q838 Q839 Q841 Q845 Q846  
 Q381 QB01 Q301 Q421 Q422 Q848 Q836 Q829 Q822 Q809 Q805 Q843 Q813 Q844 Q840 Q811 Q817 Q802 Q801 Q833 Q832  
 QB07 QB05 QB11 QB12 Q405 QP03 QP04 QD02 QD03 QD04 QX04 QX01 QX05 QX03 QX08 QX10 QX09 QX07 QX06 QX02  
 QL01 QU04 QU03 QU06 QU24 QU15 QU16 QU26 QU10 QU22 QX08 QX10 QX09 QX07 QX06 QX02

PM01 B

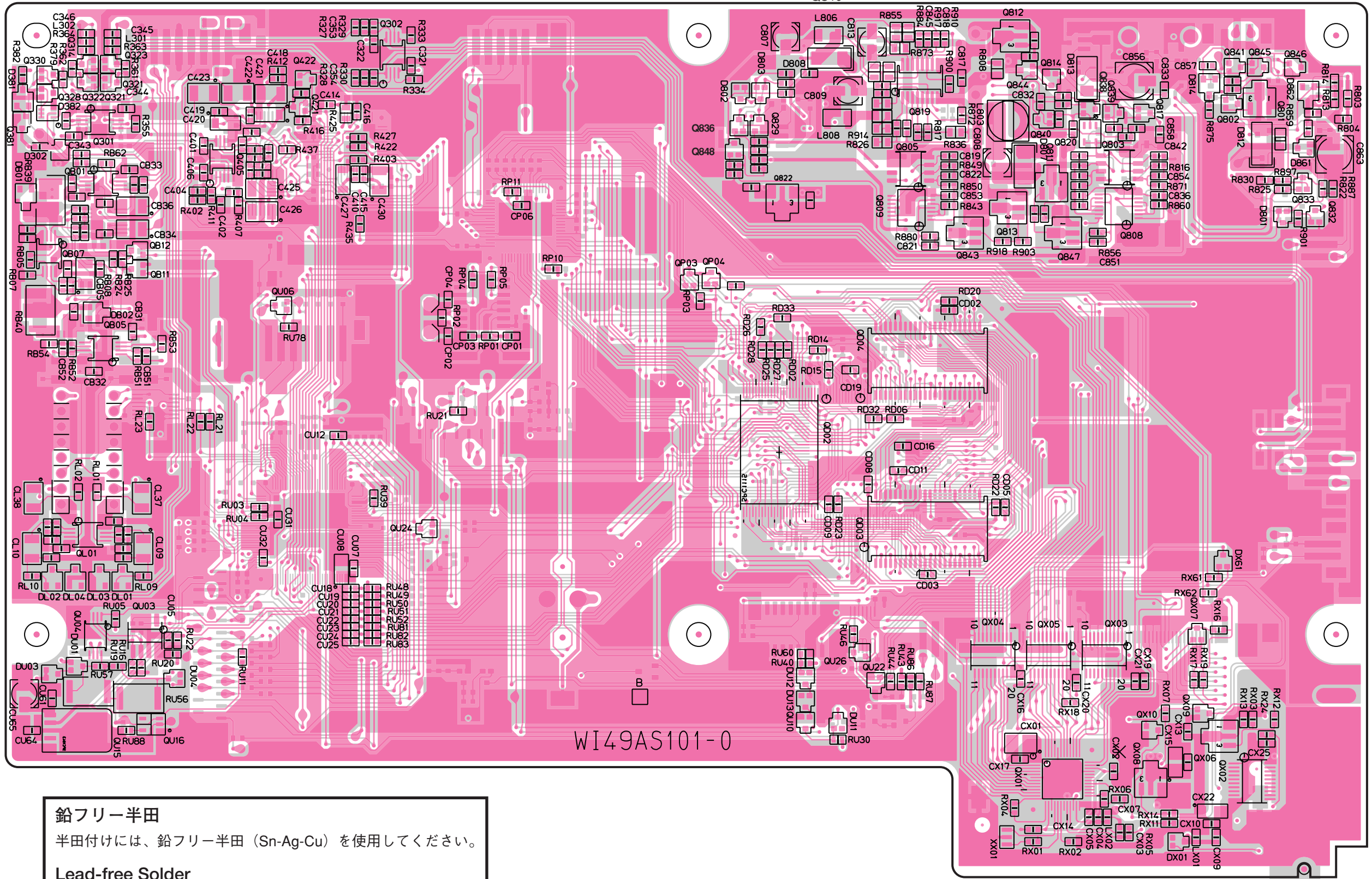

鉛フリー半田  
 半田付けには、鉛フリー半田 (Sn-Ag-Cu) を使用してください。  
 Lead-free Solder  
 When soldering, use the Lead-free Solder (Sn-Ag-Cu).

P901

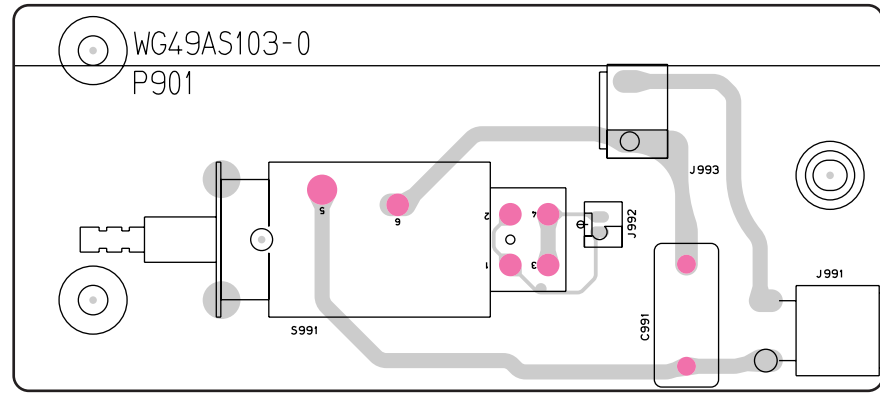

PA01

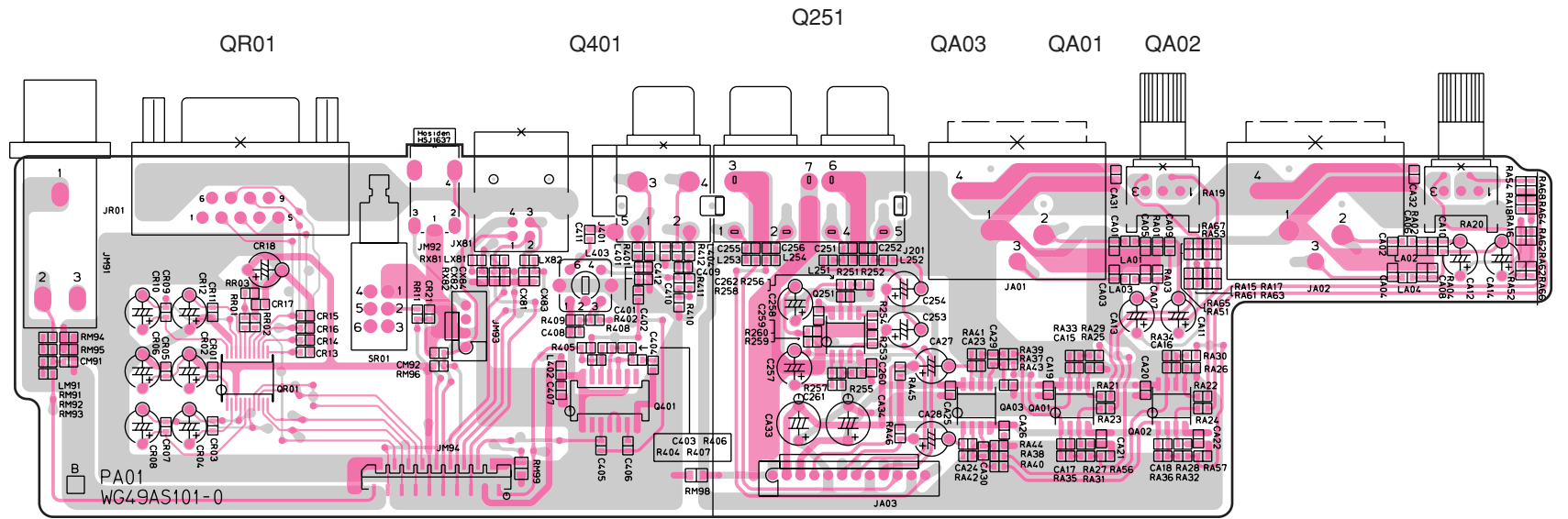

PC01

QC05 QC03 QC01  
QC06 QC04

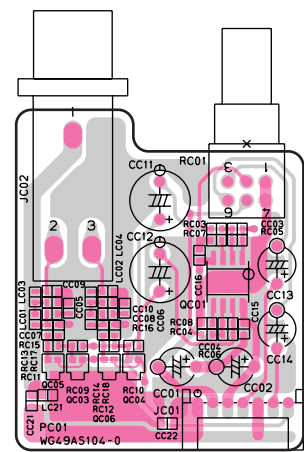

P951

Q953 Q972 Q952

Q951

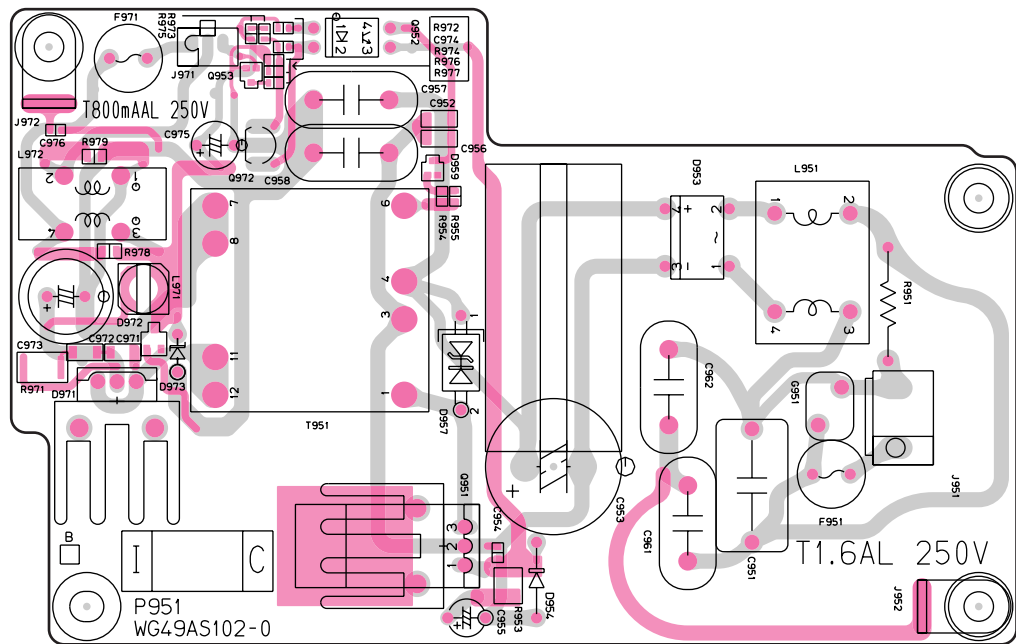

PF91

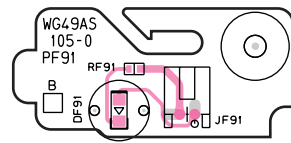

PS01

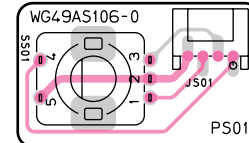

PUB1

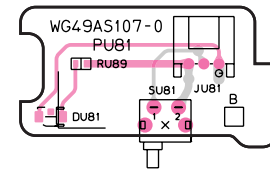

PF01 A

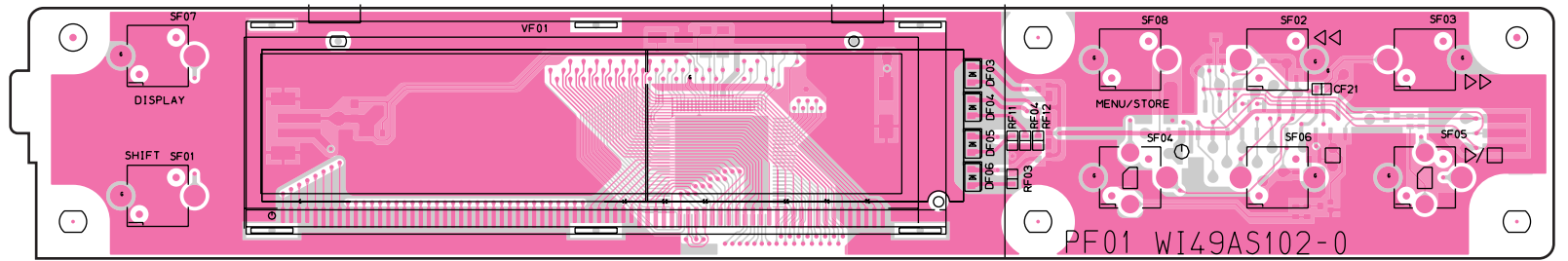

PF01 B

QF02 QF03 QF04 QF06  
QF05 QF07

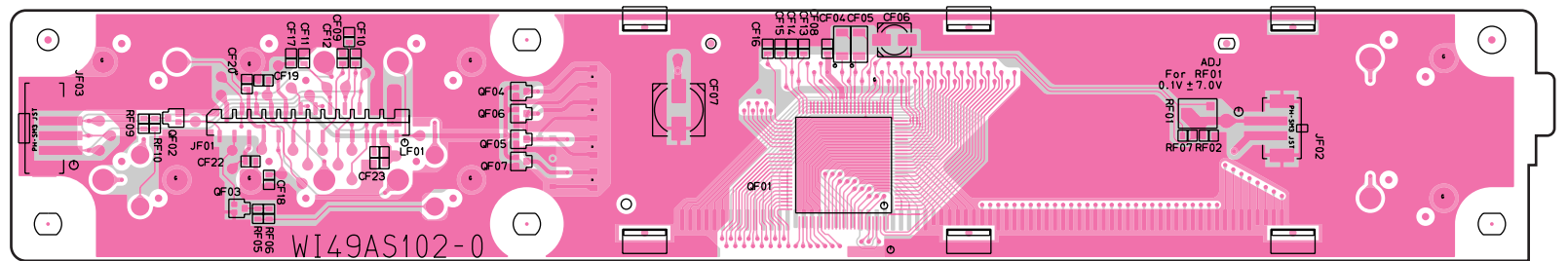

鉛フリー半田

半田付けには、鉛フリー半田 (Sn-Ag-Cu) を使用してください。

Lead-free Solder

When soldering, use the Lead-free Solder (Sn-Ag-Cu).

## 9. MICROPROCESSOR AND IC DATA

### QU01 : H8S/2328 (FRONT uP)

No	port name	I/O	USE	Sig. Name	ACT	INI	RST	PUP	Description
1	Vcc	-	-						
2	PC0	I/O	O	HPI HD0	-	-	Z		DSP (HIP)
3	PC1	I/O	O	HPI HD1	-	-	Z		DSP (HIP)
4	PC2	I/O	O	HPI HD2	-	-	Z		DSP (HIP)
5	PC3	I/O	O	HPI HD3	-	-	Z		DSP (HIP)
6	VSS			-			-		Ground
7	PC4	I/O	O	HPI HD4	-	-	Z		DSP (HIP)
8	PC5	I/O	O	HPI HD5	-	-	Z		DSP (HIP)
9	PC6	I/O	O	HPI HD6	-	-	Z		DSP (HIP)
10	PC7	I/O	O	HPI HD7	-	-	Z		DSP (HIP)
11	PB0	I/O	O	I2C Bus SCL	-	H	Z	OFF	Pull Up 22 kohm
12	PB1	I/O	I/O	I2C Bus SDA	-	H	Z	OFF	Pull Up 22 kohm
13	PB2	I/O	O	USB SW					CADR/USB
14	PB3	I/O	O	CF ENABLE SW					CADR/USB
15	VSS	I							
16	PB4	I/O	O	DV_SW (DC/DC +3.3V/5V SW)	H	L	Z	OFF	PowerSupply
17	PB5	I/O	O	AV_SW (DC/DC +8V SW)	H	L	Z	OFF	PowerSupply
18	PB6	I/O							
19	PB7	I/O							
20	PA0	I/O	O	S_MUTE	H	L	Z	OFF	for DAC
21	PA1	I/O	O	PDN	L	H	Z	OFF	for DI, DAC, ADC
22	PA2	I/O	O	DIR_INT0	-	L	Z	OFF	for DIT/DIR
23	PA3	I/O	O	DIR_INT1	-	L	Z	OFF	for DIT/DIR
24	VSS	I	-						
25	PA4	I/O	O	DIT_VIN					for DIT/DIR
26	PA5	I/O	O	XCTL0					for DIT/DIR
27	PA6	I/O	O	XCTL1					for DIT/DIR
28	PA7/IRQ7	I/O	O	BACKLIGHT				OFF	for LCD
29	P67	I/O	O	PW_LED					LED
30	P66	I/O	I	RTC_INT					RTC
31	P65/IRQ1	I/O	I	POWER__SW	L	H	Z	ON	KEY & SW
32	P64/IRQ0	I/O	I	REMOTE IN	L	H	Z		Pull Up
33	Vcc	-	-						
34	PE0	I/O	O	DB4	H	L	Z	OFF	for LCD
35	PE1	I/O	O	DB5	H	L	Z	OFF	for LCD
36	PE2	I/O	O	DB6	H	L	Z	OFF	for LCD
37	PE3	I/O	O	DB7	H	L	Z	OFF	for LCD
38	VSS	I							
39	PE4	I/O	O	LRESET	H	L	Z	OFF	for LCD
40	PE5	I/O	O	RW	H	L	Z	OFF	for LCD
41	PE6	I/O	O	RS	H	L	Z	OFF	for LCD
42	PE7	I/O	O	E	H	L	Z	OFF	for LCD
43	PD0	I/O	O	(L+R)/2	H	L	Z	OFF	Audio
44	PD1	I/O	O	ST_MONO	H	L	Z	OFF	Audio
45	PD2	I/O	O	BALANCE	L	H	Z		Audio
46	PD3	I/O	O	MENU	L	H	Z		KEY & SW
47	VSS	I	-	-	-	-	-	-	
48	PD4	I/O	O	DISPLAY	L	H	Z		KEY & SW
49	PD5	I/O							
50	PD6	I/O	I	RTS					RS232C
51	PD7	I/O	O	CTS					RS232C
52	Vcc	-	-						
53	P30/TXD0	I/O							
54	P31/TXD1	I/O	O	TXD					RS232C
55	P32/RXD0	I/O							
56	P33/RXD1	I	I	RXD					RS232C
57	P34/SCK0	I/O	I	TRSTn					E10A(UDI2)
58	P35/SCK1	I/O	I	SCK					RS232C
59	VSS	I	-	-			-		Ground
60	P60	I/O	I	TMS					E10A(UDI5)

**QU01 : H8S/2328 (FRONT uP)**

No.	port name	I/O	USE	Sig. Name	ACT	INI	RST	PUP	Description
61	P61	I/O	I	TCK					E10A (UD11)
62	P62	I/O	I	TDI					E10A (UD16)
63	P63	I/O	O	TDO					E10A (UD13)
64	P27	I/O							
65	P26	I/O							
66	P25	I/O							
67	P24	I/O							
68	P23	I/O	O	PLAY_LED					LED
69	P22	I/O	O	DB_CK					Audio
70	P21	I/O	O	DB_STB					Audio
71	P20	I/O	O	DB_DATA					Audio
72	WDTOVF								
73	RES	I	I	-			I		Pull Up
74	NMI	I	I	-			I		Pull Up
75	STBY	I	I	-			I		Pull Up
76	Vcc	-	-	+3.3V			-		
77	XTAL	O	O	24.576 MHz			O		
78	EXTAL	I	I	24.576 MHz			I		
79	VSS	I	-	-			-		Ground
80	PF7	I	I	CARD_EJECT	L	H	Z		Pull Up
81	Vcc	-	-	+3.3V'			-		
82	PF6	I/O	I	PLAY	L	H	Z		Pull Up
83	PF5	I/O	I	STOP	L	H	Z		Pull Up
84	PF4	I/O	I	REC_P	L	H	Z		Pull Up
85	PF3	I/O	I	MODE	L	H	Z		Pull Up
86	PF2	I/O	I	FF	L	H	Z		Pull Up
87	PF1	I/O	I	RWD	L	H	Z		Pull Up
88	PF0	I/O	I	JOG_ENTER	L	H	Z		KEY & SW
89	P50	I/O	O	LINE-MUTE	H	L	Z		Audio
90	P51	I/O	O	HP-MUTE	H	L	Z		Audio
91	P52	I/O							
92	P53	I/O							
93	ACVV	I	-	+5V			-		
94	Vref								
95	P40	I	ADC						
96	P41	I	ADC						
97	P42	I	I						
98	P43	I	I	HRDY	-	-	Z		for DSP
99	P44	I	I	CARD IN	L	H	Z		Pull Up
100	P45	I	I	USB IN	H	L	Z		CD1 & CD2 & USB1
101	P46	I	I						
102	P47	I	I						
103	AVSS	I	-	Ground	-	-	-		Ground
104	VSS	I	-	-			-		Ground
105	P17	I/O	O	DSP_PW					for DSP
106	P16	I/O	O	HCNTL1	H	H	Z		for DSP
107	P15	I/O	O	HCNTL0	H	H	Z		for DSP
108	P14	I/O	I	Reserve					
109	P13/TIOCD0	I/O	I	ENCORDER_B					
110	P12/TIOCC0	I/O	I	ENCORDER_A					
111	P11/TIOCB0	I/O	O	REC LED	H	L	Z		RED LED
112	P10/TIOCA0	I/O	O	HRESET#	L	H	Z		for DSP
113	MD0	I	I	Mode 7			I		Pull Up
114	MD1	I	I	Mode 7			I		Pull Up
115	MD2	I	I	Mode 7			I		Pull Up
116	PG0	I/O	O	HBIL	H	L	Z		for DSP
117	PG1	I/O	O	HDS#	L	H	Z		for DSP
118	PG2	I/O	O	HRW#	L	H	Z		for DSP
119	PG3	I/O	O	HCS#	L	H	Z		for DSP
120	PG4	I/O	O	DSP_INT					for DSP



**QX01 : GL641USB (USB DRIVER)**

Pin No.	Name	I/O	Description
1	PVDD	PWR	Power supplier for storage device interface
2	D8	I/O	Storage device data bus bit 8*
3	D9	I/O	Storage device data bus bit 9*
4	D10	I/O	Storage device data bus bit 10*
5	D11	I/O	Storage device data bus bit 11*
6	PGND	PWR	Ground for storage device interface
7	D12	I/O	Storage device data bus bit 12*
8	D13	I/O	Storage device data bus bit 13*
9	D14	I/O	Storage device data bus bit 14*
10	D15	I/O	Storage device data bus bit 15*
11	DIOR#	O	Storage device read strobe signal*
12	DIOW#	O	Storage device write strobe signal*
13	INTRQ	I	Storage device interrupt request signal*
14	DVDD	PWR	5V power supplier for internal logic
15	DGND	PWR	Ground for internal logic
16	Crystal out	CLK	Crystal clock output
17	Crystal in	CLK	Crystal clock input
18	GPIO1	I/O	General purpose I/O 1
19	GPIO2	I/O	General purpose I/O 2
20	V3.3	USB	3.3v power supplier for USB bus
21	D+	USB	D+ signal for USB
22	D-	USB	D- signal for USB
23	AVDD	PWR	5V power supplier for USB interface
24	AGND	PWR	Ground for USB interface
25	GPIO3	I/O	General purpose I/O 3
26	GPIO4	I/O	General purpose I/O 4
27	TSTMODE	I	Used at test mode only
28	EXTRST#	I	Used at test mode only
29	GPIO8	I/O	General purpose I/O 8
30	GPIO7	I/O	General purpose I/O 7
31	GPIO6	I/O	General purpose I/O 6
32	GPIO5	I/O	General purpose I/O 5
33	DGND	PWR	Ground for internal logic
34	DVDD	PWR	5V power supplier for internal logic
35	CS3FX#	O	Storage device register bank 3 selector*
36	CS1FX#	O	Storage device register bank 1 selector*
37	A0	O	Storage device address bus bit 0*
38	A1	O	Storage device address bus bit 1*
39	A2	O	Storage device address bus bit 2*
40	D0	I/O	Storage device data bus bit 0*
41	D1	I/O	Storage device data bus bit 1*
42	D2	I/O	Storage device data bus bit 2*
43	D3	I/O	Storage device data bus bit 3*
44	PGND	PWR	Ground for storage device interface
45	D4	I/O	Storage device data bus bit 4*
46	D5	I/O	Storage device data bus bit 5*
47	D6	I/O	Storage device data bus bit 6*
48	D7	I/O	Storage device data bus bit 7*

\* Output voltage of this pin is equivalent to voltage supplied by PVDD.  
 Input voltage of this pin can be from 0v to 5v, and its threshold is 1v ~ 2v.  
 Therefore, these pins can support 3v/5v interface according to voltage of PVDD.

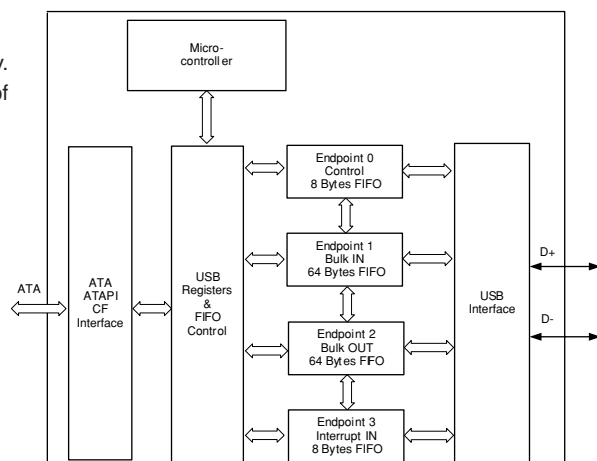

Q401 : AK4114 DIT

No.	Pin Name	I/O	Function
1	IPS0	I	Input Channel Select 0 Pin in Parallel Mode
	RX4	I	Receiver Channel 4 Pin in Serial Mode (Internal biased pin)
2	NC(AVSS)	I	No Connect No internal bonding. This pin should be connected to AVSS.
3	DIF0	I	Audio Data Interface Format 0 Pin in Parallel Mode
	RX5	I	Receiver Channel 5 Pin in Serial Mode (Internal biased pin)
4	TEST2	I	TEST 2 pin This pin should be connect to AVSS.
5	DIF1	I	Audio Data Interface Format 1 Pin in Parallel Mode
	RX6	I	Receiver Channel 6 Pin in Serial Mode (Internal biased pin)
6	NC(AVSS)	I	No Connect No internal bonding. This pin should be connected to AVSS.
7	DIF2	I	Audio Data Interface Format 2 Pin in Parallel Mode
	RX7	I	Receiver Channel 7 Pin in Serial Mode (Internal biased pin)
8	IPS1	I	Input Channel Select 1 Pin in Parallel Mode
	IIC I		IIC Select Pin in Serial Mode. L : 4-wire Serial, H : IIC
9	P/SN	I	Parallel/Serial Select Pin L : Serial Mode, H : Parallel Mode
10	XTL0	I	X tal Frequency Select 0 Pin
11	XTL1	I	X tal Frequency Select 1 Pin
12	VIN	I	V-bit Input Pin for Transmitter Output
13	TVDD	I	Input Buffer Power Supply Pin, 3.3V or 5V
14	NC	I	No Connect No internal bonding. This pin should be open or connected to DVSS.
15	TX0	O	Transmit Channel (Through Data) Output 0 Pin
16	TX1	O	When TX bit = 0 , Transmit Channel (Through Data) Output 1 Pin. When TX bit = 1 , Transmit Channel (DAUX Data) Output Pin (Default).
17	BOUT	O	Block-Start Output Pin for Receiver Input H during first 40 frames.
18	COUT	O	C-bit Output Pin for Receiver Input
19	UOUT	O	U-bit Output Pin for Receiver Input
20	VOUT	O	V-bit Output Pin for Receiver Input
21	DVDD	I	Digital Power Supply Pin, 3.3V
22	DVSS	I	Digital Ground Pin
23	MCKO1	O	Master Clock Output 1 Pin
24	LRCK	I/O	Channel Clock Pin
25	SDTO	O	Audio Serial Data Output Pin
26	BICK	I/O	Audio Serial Data Clock Pin
27	MCKO2	O	Master Clock Output 2 Pin
28	DAUX	I	Auxiliary Audio Data Input Pin
29	XTO	O	X'tal Output Pin
30	XTI	I	X'tal Input Pin

No.	Pin Name	I/O	Function
31	PDN	I	Power-Down Mode Pin When L , the AK4114 is powered-down and reset.
32	CM0	I	Master Clock Operation Mode 0 Pin in Parallel Mode
	CDTO	O	Control Data Output Pin in Serial Mode, IIC= L .
	CAD1	I	Chip Address 1 Pin in Serial Mode, IIC= H .
33	CM1	I	Master Clock Operation Mode 1 Pin in Parallel Mode
	CDTI	I	Control Data Input Pin in Serial Mode, IIC= L .
	SDA	I/O	Control Data Pin in Serial Mode, IIC= H .
34	OCKS1	I	Output Clock Select 1 Pin in Parallel Mode
	CCLK	I	Control Data Clock Pin in Serial Mode, IIC= L
	SCL	I	Control Data Clock Pin in Serial Mode, IIC= H
35	OCKS0	I	Output Clock Select 0 Pin in Parallel Mode
	CSN	I	Chip Select Pin in Serial Mode, IIC= L .
	CAD0	I	Chip Address 0 Pin in Serial Mode, IIC= H .
36	INT0	O	Interrupt 0 Pin
37	INT1	O	Interrupt 1 Pin
38	AVDD	I	Analog Power Supply Pin, 3.3V
39	R	-	External Resistor Pin 18k +/-1% resistor should be connected to AVSS externally.
40	VCOM	-	Common Voltage Output Pin 0.47 F capacitor should be connected to AVSS externally.
41	AVSS	I	Analog Ground Pin
42	RX0	I	Receiver Channel 0 Pin (Internal biased pin) This channel is default in serial mode.
43	NC(AVSS)	I	No Connect No internal bonding. This pin should be connected to AVSS.
44	RX1	I	Receiver Channel 1 Pin (Internal biased pin)
45	TEST1	I	TEST 1 pin. This pin should be connected to AVSS.
46	RX2	I	Receiver Channel 2 Pin (Internal biased pin)
47	NC(AVSS)	I	No Connect No internal bonding. This pin should be connected to AVSS.
48	RX3	I	Receiver Channel 3 Pin (Internal biased pin)

Note 1. All input pins except internal biased pins should not be left floating.

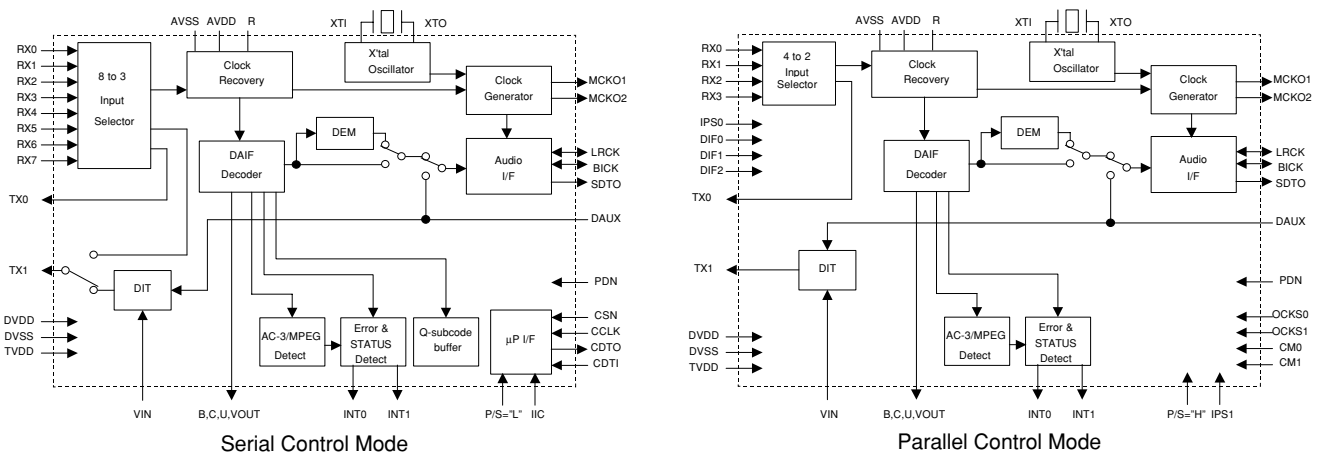

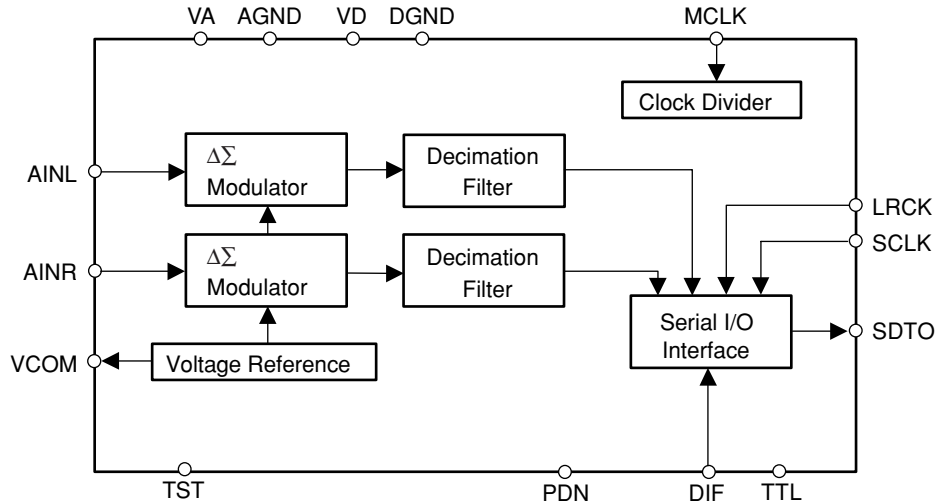

No.	Pin Name	I/O	Description
1	AINR	I	Rch Analog Input Pin
2	AINL	I	Lch Analog Input Pin
3	NC	-	NC Pin No internal bonding.
4	VCOM	O	Common Voltage Output Pin Normally connected to AGND with a 0.1μF ceramic capacitor in parallel with an electrolytic capacitor less than 2.2μF.
5	AGND	-	Analog Ground Pin, 0V
6	VA	-	Analog Power Supply Pin, +4.5 to +5.5V
7	VD	-	Digital Power Supply Pin, +2.7 to +5.5V(fs=48kHz), +4.5 to +5.5V(fs=96kHz)
8	DGND	-	Digital Ground Pin, 0V
9	SDTO	O	Serial Data Output Pin Data bits are presented MSB first, in 2 s complement format. This pin is L in the power-down mode.
10	LRCK	I	Left/Right Channel Select Pin The fs clock is input to this pin.
11	MCLK	I	Master Clock Input Pin
12	SCLK	I	Serial Data Input Pin Output data is clocked out on the falling edge of SCLK.
13	PDN	I	Power-Down Pin When L, the circuit is in power-down mode. The AK5380 should always be reset upon power-up.
14	DIF	I	Serial Interface Format Pin L : MSB justified, H : I <sup>2</sup> S
15	TTL	I	Digital Input Level Select Pin L : CMOS level (VD=2.7 to 5.5V), H : TTL level (VD=4.5 to 5.5V)
16	TST	I	Test Pin (Internal pull-down pin) This pin should be left open.

Note: All input pins except pull-down pins should not be left floating.

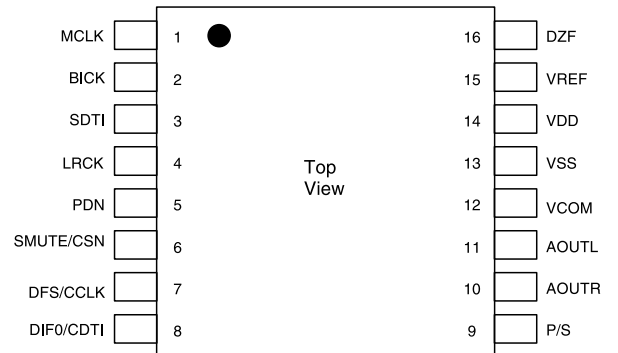
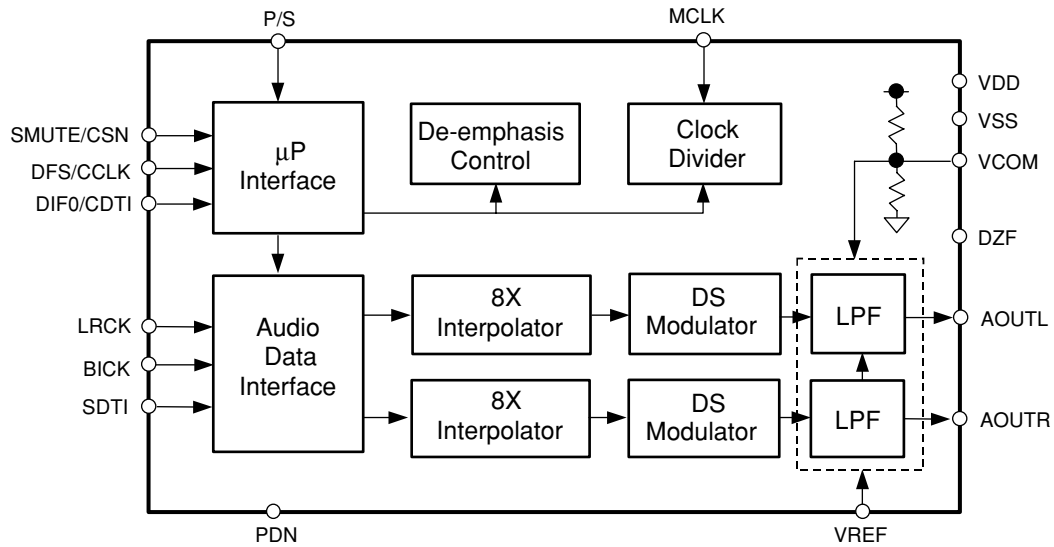

No.	Pin Name	I/O	Function
1	MCLK	I	Master Clock Input Pin An external TTL clock should be input on this pin.
2	BICK	I	Audio Serial Data Clock Pin
3	SDTI	I	Audio Serial Data Input Pin
4	LRCK	I	L/R Clock Pin
5	PDN	I	Power-Down Mode Pin When at "L", the AK4380 is in the power-down mode and is held in reset. The AK4380 should always be reset upon power-up.
6	SMUTE	I	Soft Mute Pin in parallel mode "H": Enable, "L": Disable
	CSN	I	Chip Select Pin in serial mode
7	DFS	I	Double Speed Sampling Mode Pin in parallel mode "L": Normal Speed, "H": Double Speed
	CCLK	I	Control Data Input Pin in serial mode
8	DIF0	I	Audio Data Interface Format Pin in parallel mode
	CDTI	I	Control Data Input Pin in serial mode
9	P/S	I	Parallel/Serial Select Pin (Internal pull-up pin) "L": Serial control mode, "H": Parallel control mode
10	AOUTR	O	Rch Analog Output Pin
11	AOUTL	O	Lch Analog Output Pin
12	VCOM	O	Common Voltage Pin, VDD/2 Normally connected to VSS with a 0.1 $\mu$ F ceramic capacitor in parallel with a 10 $\mu$ F electrolytic cap.
13	VSS	-	Ground Pin
14	VDD	-	Power Supply Pin
15	VREF	I	Voltage Reference Input Pin
16	DZF	O	Data Zero Input Detect Pin When SDTI of both channels follow a total 8192 LRCK cycles with "0" input data, this pin goes to "H".

Note: All input pins except pull-up pin should not be left floating.

**QP01 : XC9536XL-VQ64-10C**

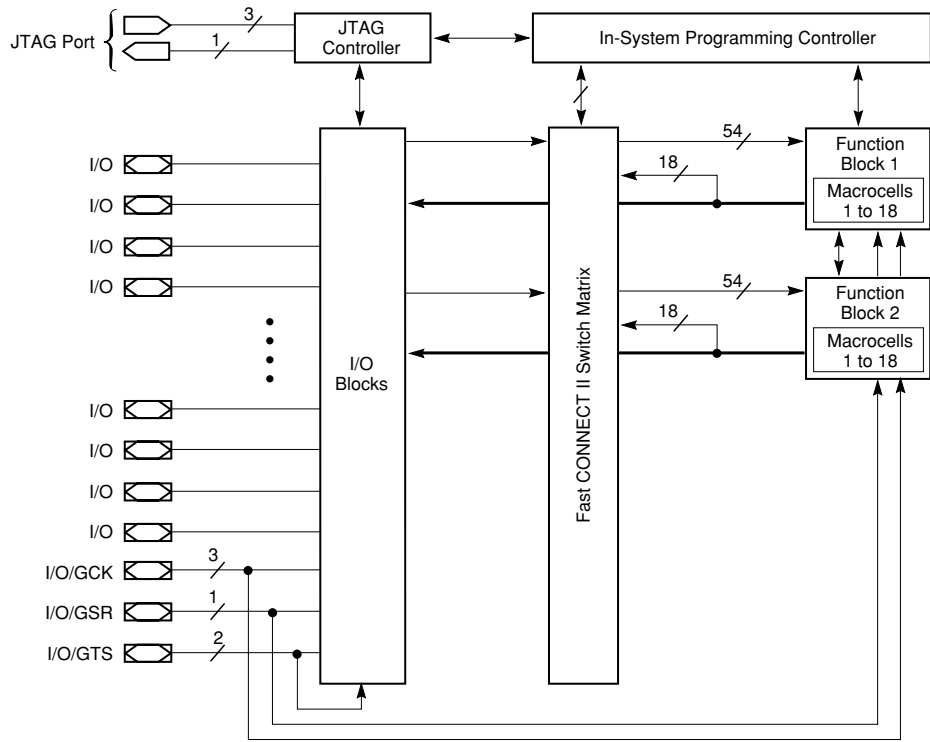

**QD02 : M29W800AB80N5**

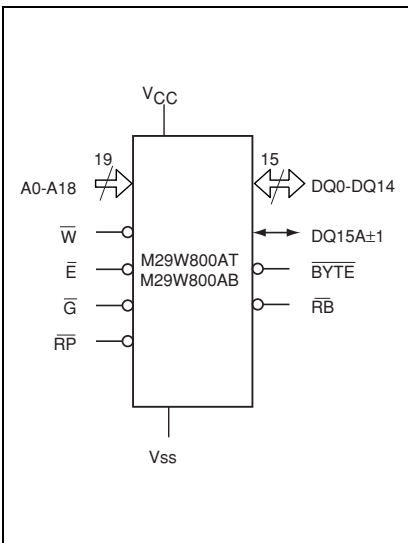

**QD03/QD04 : M68AW256M70ND1**

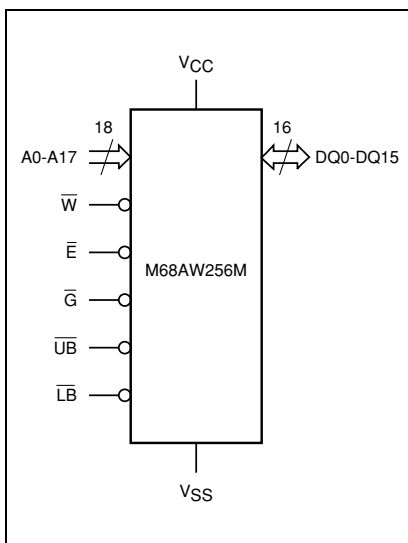

A0-A17	Address Inputs
DQ0-DQ15	Data Input/Output
$\bar{E}$	Chip Enable
$\bar{G}$	Output Enable
$\bar{W}$	Write Enable
$\bar{U}\bar{B}$	Upper Byte Enable Input
$\bar{L}\bar{B}$	Lower Byte Enable Input
VCC	Supply Voltage
VSS	Ground
NC	Not Connected Internally
DU	Don't Use as Internally Connected

**Q808/Q809 : MC74VHC14DT**

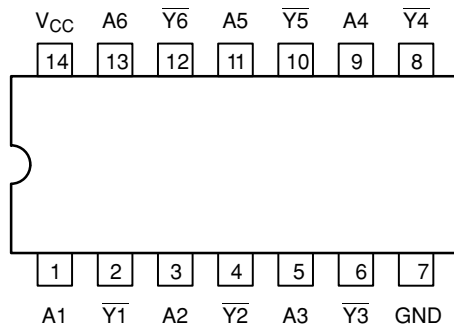
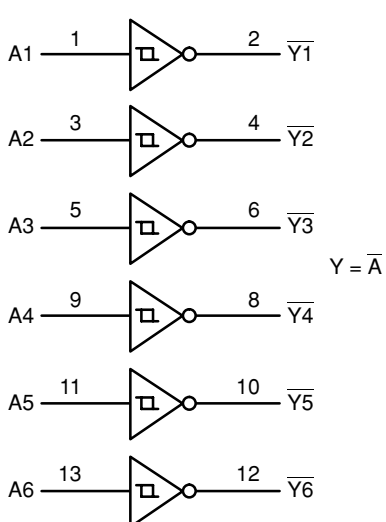

Inputs	Outputs
A	$\bar{Y}$
L	H
H	L

**LOGIC DIAGRAM**

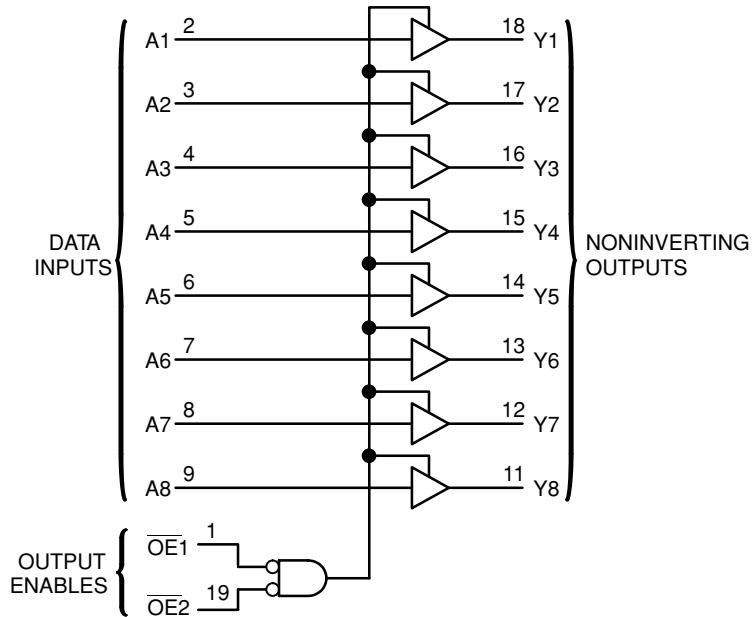

**PIN ASSIGNMENT**

$\overline{OE1}$	1	20	$V_{CC}$
A1	2	19	$\overline{OE2}$
A2	3	18	Y1
A3	4	17	Y2
A4	5	16	Y3
A5	6	15	Y4
A6	7	14	Y5
A7	8	13	Y6
A8	9	12	Y7
GND	10	11	Y8

**FUNCTION TABLE**

Inputs			Output Y
$\overline{OE1}$	$\overline{OE2}$	A	
L	L	L	L
L	L	H	H
H	X	X	Z
X	H	X	Z

**IEC LOGIC DIAGRAM**

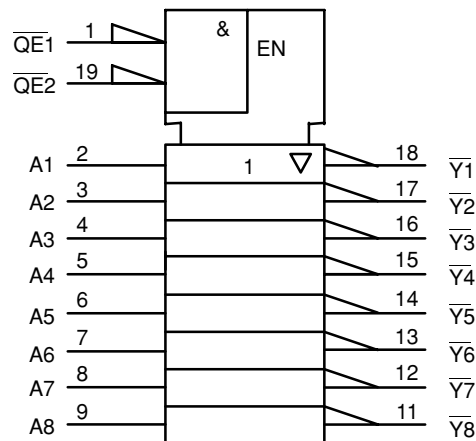

**QB06 : BU4053BCV**

Block diagram

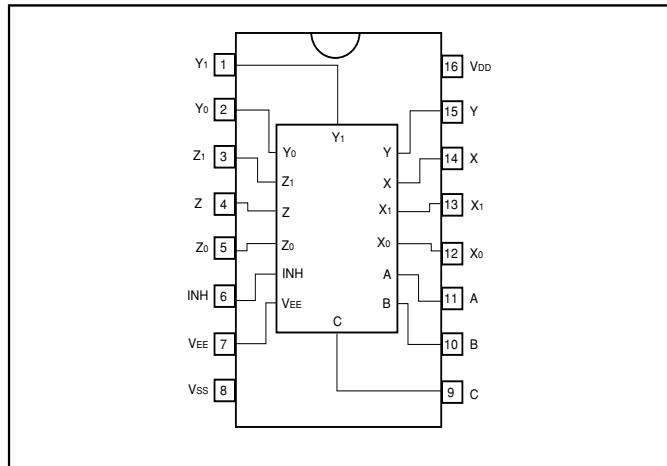

Logic circuit diagram

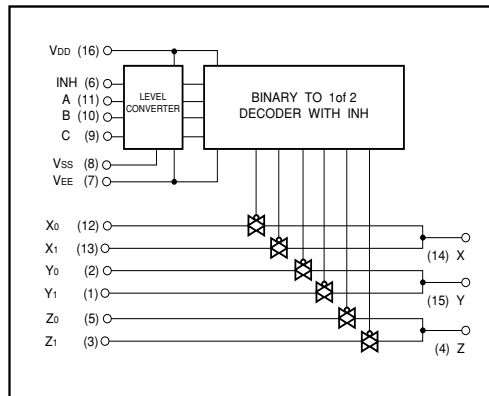

Truth table

INH	A	B	C	ON SWITCH
L	L	L	L	X <sub>0</sub> Y <sub>0</sub> Z <sub>0</sub>
L	H	L	L	X <sub>1</sub> Y <sub>0</sub> Z <sub>0</sub>
L	L	H	L	X <sub>0</sub> Y <sub>1</sub> Z <sub>0</sub>
L	H	H	L	X <sub>1</sub> Y <sub>1</sub> Z <sub>0</sub>
L	L	L	H	X <sub>0</sub> Y <sub>0</sub> Z <sub>1</sub>
L	H	L	H	X <sub>1</sub> Y <sub>0</sub> Z <sub>1</sub>
L	L	H	H	X <sub>0</sub> Y <sub>1</sub> Z <sub>1</sub>
L	H	H	H	X <sub>1</sub> Y <sub>1</sub> Z <sub>1</sub>
H	X	X	X	NONE

X: Irrelevant

**QB08 : BU4052BCF**

Block diagram

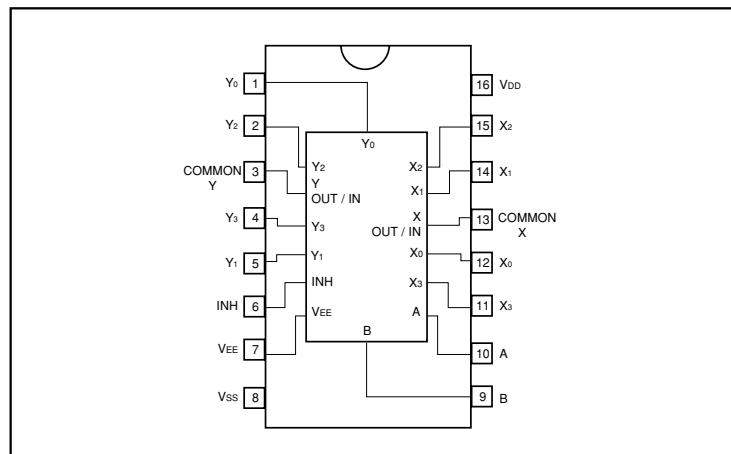

Logic circuit diagram

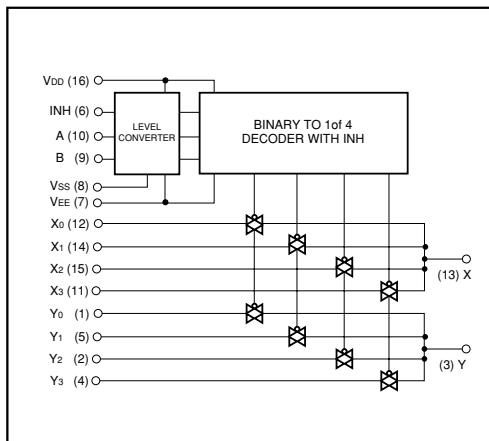

Truth table

INH	A	B	ON SWITCH
L	L	L	X <sub>0</sub> Y <sub>0</sub>
L	H	L	X <sub>1</sub> Y <sub>1</sub>
L	L	H	X <sub>2</sub> Y <sub>2</sub>
L	H	H	X <sub>3</sub> Y <sub>3</sub>
H	X	X	NONE

X: Irrelevant



QR01 :  $\mu$ PD4721GS-GJG

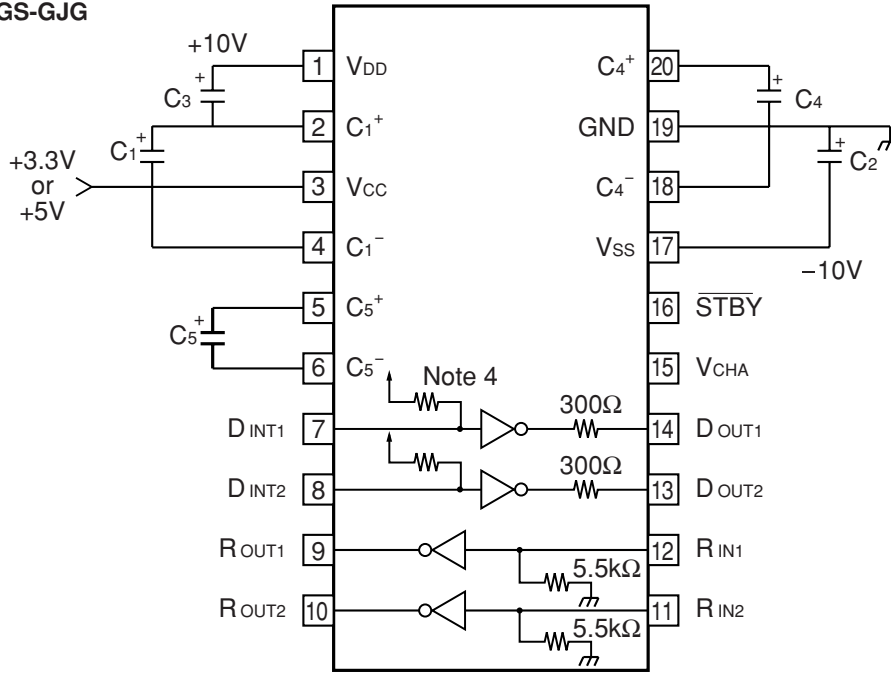

Q819 : BA9741FS-E2

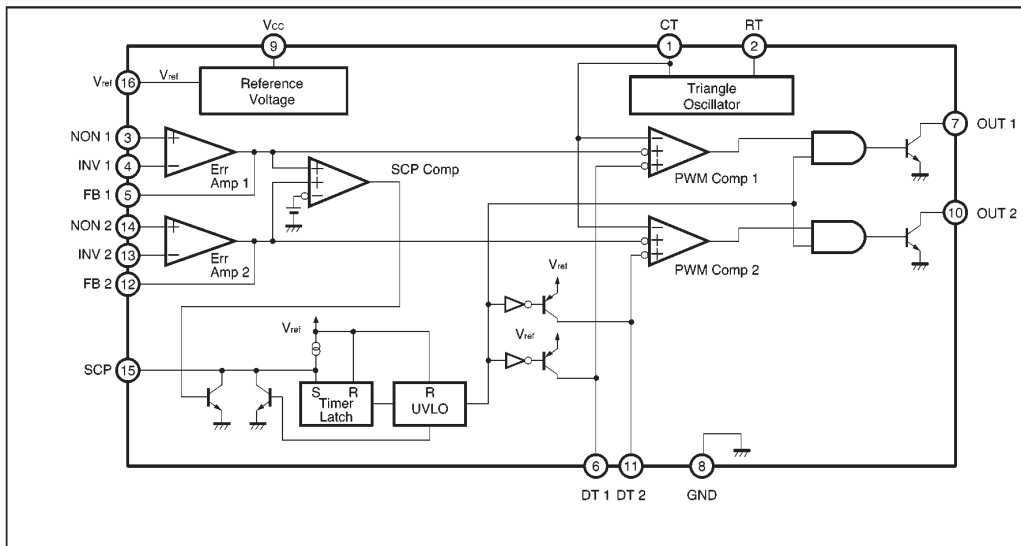

Pin No.	Pin name	Function
1	CT	External timing capacitor
2	RT	External timing resistor
3	NON1	Positive input for error amplifier 1
4	INV1	Negative input for error amplifier 1
5	FB1	Error amplifier 1 output
6	DT1	Output 1 dead time / soft start setting
7	OUT1	Output 1
8	GND	Ground
9	Vcc	Power supply
10	OUT2	Output 2
11	DT2	Output 2 dead time / soft start setting
12	FB2	Error amplifier 2 output
13	INV2	Negative input for error amplifier 2
14	NON2	Positive input for error amplifier 2
15	SCP	Time latch setting
16	Vref	Reference voltage output (2.5V)

**Q820 : NJM2373-AF**

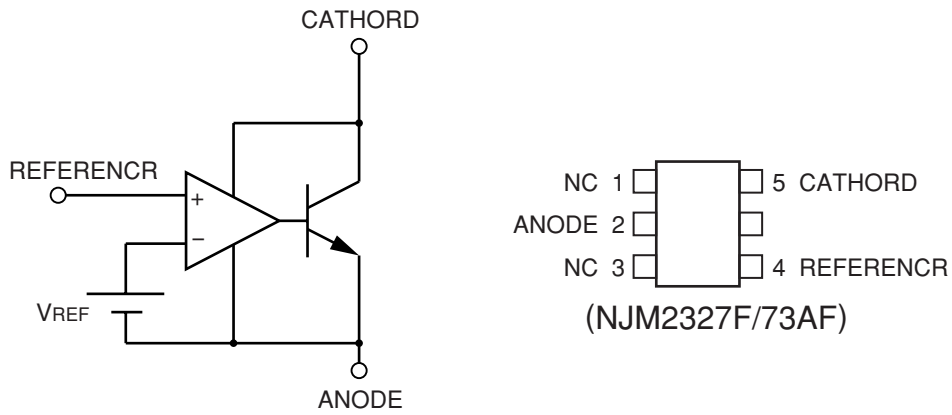

**QF01 : NJU6469LFG1**

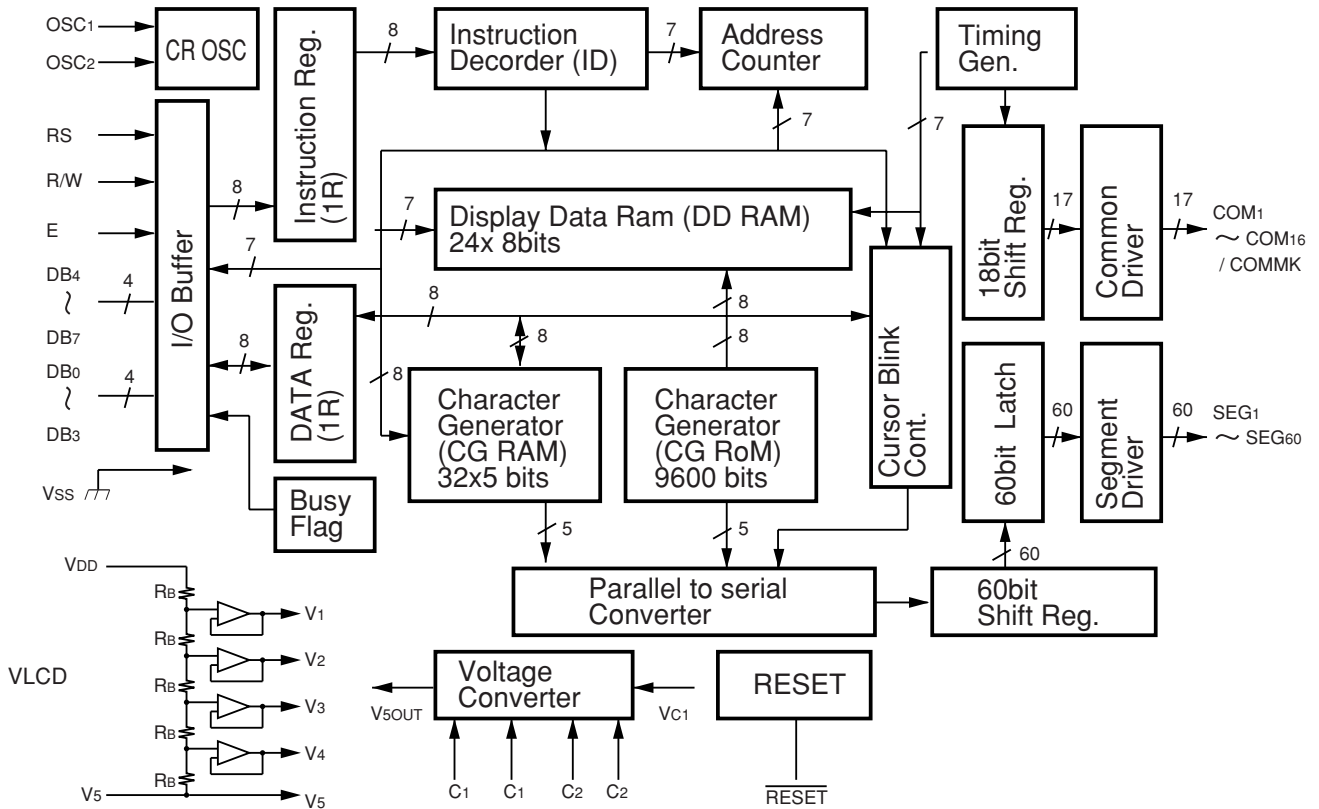

The TMS320VC5416PGE 144-pin low-profile quad flatpack (LQFP) pin assignments are shown in Figure 2-2.

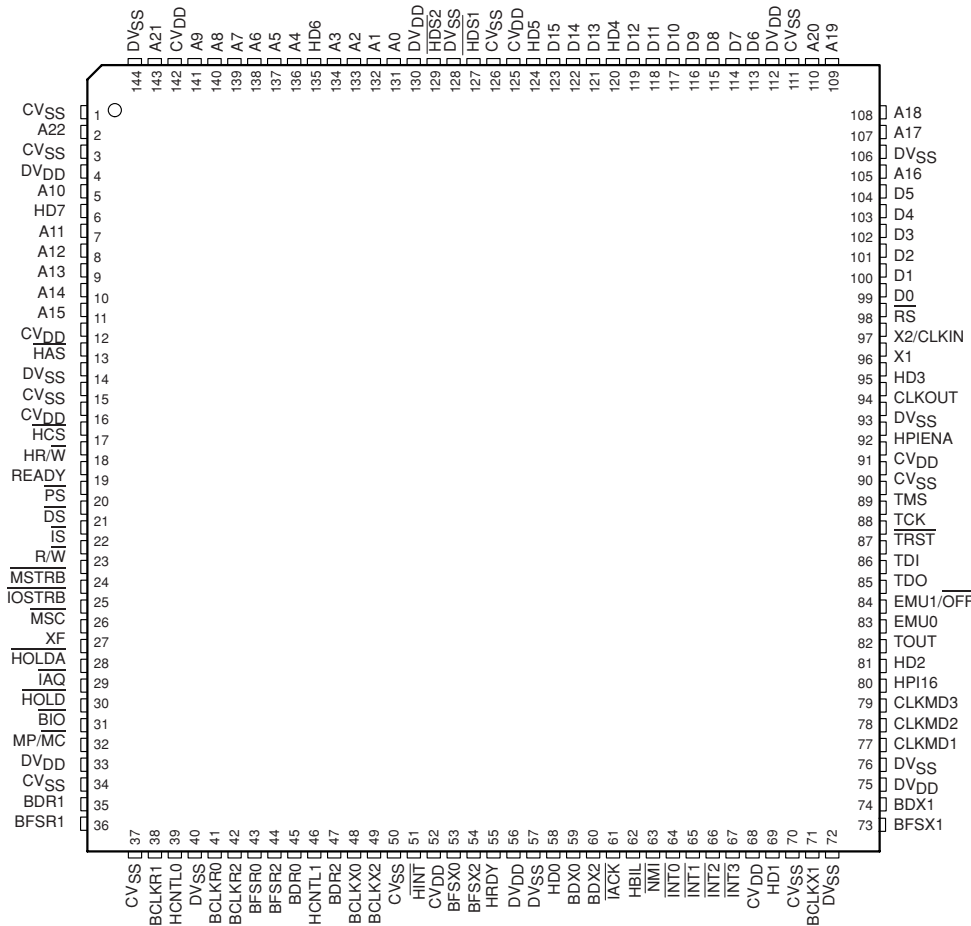

Signal Descriptions

Table 11-1 lists each signal, function, and operating mode(s) grouped by function. See Section 2.2 for exact pin locations based on package type.

Table 11-1 Signal Descriptions

TERMINAL NAME	I/O†	DESCRIPTION
<b>DATA SIGNALS</b>		
A22 (MSB) A21 A20 A19 A18 A17 A16 A15 A14 A13 A12 A11 A10 A9 A8 A7 A6 A5 A4 A3 A2 A1 A0 (LSB)	I/O/Z‡§	Parallel address bus A22 [most significant bit (MSB)] through A0 [least significant bit (LSB)]. The sixteen LSB lines, A0 to A15, are multiplexed to address external memory (program, data) or I/O. The seven MSB lines, A16 to A22, address external program space memory. A22–A0 is placed in the high-impedance state in the hold mode. A22–A0 also goes into the high-impedance state when OFF is low.  A17–A0 are inputs in HPI16 mode. These pins can be used to address internal memory via the host-port interface (HPI) when the HPI16 pin is high. These pins also have Schmitt trigger inputs.  The address bus has a bus holder feature that eliminates passive components and the power dissipation associated with them. The bus holder keeps the address bus at the previous logic level when the bus goes into a high-impedance state.
D15 (MSB) D14 D13 D12 D11 D10 D9 D8 D7 D6 D5 D4 D3 D2 D1 D0 (LSB)	I/O/Z‡§	Parallel data bus D15 (MSB) through D0 (LSB). D15–D0 is multiplexed to transfer data between the core CPU and external data/program memory or I/O devices or HPI in HPI16 mode (when HPI16 pin is high). D15–D0 is placed in the high-impedance state when not outputting data or when RS or HOLD is asserted. D15–D0 also goes into the high-impedance state when OFF is low. These pins also have Schmitt trigger inputs.  The data bus has a bus holder feature that eliminates passive components and the power dissipation associated with them. The bus holder keeps the data bus at the previous logic level when the bus goes into the high-impedance state. The bus holders on the data bus can be enabled/disabled under software control.

TERMINAL NAME	I/O†	DESCRIPTION
<b>INITIALIZATION, INTERRUPT AND RESET OPERATIONS</b>		
IACK	O/Z	Interrupt acknowledge signal. IACK indicates receipt of an interrupt and that the program counter is fetching the interrupt vector location designated by A15–A0. IACK also goes into the high-impedance state when OFF is low.
INT0‡ INT1‡ INT2‡ INT3‡	I	External user interrupt inputs. INT0–INT3 are maskable and are prioritized by the interrupt mask register (IMR) and the interrupt mode bit. INT0–INT3 can be polled and reset by way of the interrupt flag register (IFR).
NMI‡	I	Nonmaskable interrupt. NMI is an external interrupt that cannot be masked by way of the INTM or the IMR. When NMI is activated, the processor traps to the appropriate vector location.
RS‡	I	Reset. RS causes the digital signal processor (DSP) to terminate execution and forces the program counter to 0FF80h. When RS is brought to a high level, execution begins at location 0FF80h of program memory. RS affects various registers and status bits.
MP/MC	I	Microprocessor/microcomputer mode select. If active low at reset, microcomputer mode is selected, and the internal program ROM is mapped into the upper 16K words of program memory space. If the pin is driven high during reset, microprocessor mode is selected, and the on-chip ROM is removed from program space. This pin is only sampled at reset, and the MP/MC bit of the processor mode status (PMST) register can override the mode that is selected at reset.
<b>MULTIPROCESSING SIGNALS</b>		
BIO‡	I	Branch control. A branch can be conditionally executed when BIO is active. If low, the processor executes the conditional instruction. The BIO condition is sampled during the decode phase of the pipeline for the XC instruction, and all other instructions sample BIO during the read phase of the pipeline.
XF	O/Z	External flag output (latched software-programmable signal). XF is set high by the SSBX XF instruction, set low by RSBX XF instruction or by loading ST1. XF is used for signaling other processors in multiprocessor configurations or used as a general-purpose output pin. XF goes into the high-impedance state when OFF is low, and is set high at reset.
<b>MEMORY CONTROL SIGNALS</b>		
DS PS IS	O/Z	Data, program, and I/O space select signals. DS, PS, and IS are always high unless driven low for communicating to a particular external space. Active period corresponds to valid address information. DS, PS, and IS are placed into the high-impedance state in the hold mode; these signals also go into the high-impedance state when OFF is low.
MSTRB	O/Z	Memory strobe signal. MSTRB is always high unless low-level asserted to indicate an external bus access to data or program memory. MSTRB is placed in the high-impedance state in the hold mode; it also goes into the high-impedance state when OFF is low.
READY	I	Data ready. READY indicates that an external device is prepared for a bus transaction to be completed. If the device is not ready (READY is low), the processor waits one cycle and checks READY again. Note that the processor performs ready detection if at least two software wait states are programmed. The READY signal is not sampled until the completion of the software wait states.
R/W	O/Z	Read/write signal. R/W indicates transfer direction during communication to an external device. R/W is normally in the read mode (high), unless it is asserted low when the DSP performs a write operation. R/W is placed in the high-impedance state in the hold mode, and it also goes into the high-impedance state when OFF is low.
IOSTRB	O/Z	I/O strobe signal. IOSTRB is always high unless low-level asserted to indicate an external bus access to an I/O device. IOSTRB is placed in the high-impedance state in the hold mode; it also goes into the high-impedance state when OFF is low.
HOLD	I	Hold input. HOLD is asserted to request control of the address, data, and control lines. When acknowledged by the 5416, these lines go into the high-impedance state.

TERMINAL NAME	I/O†	DESCRIPTION
<b>MEMORY CONTROL SIGNALS (CONTINUED)</b>		
HOLDA	O/Z	Hold acknowledge. HOLDA indicates to the external circuitry that the processor is in a hold state and that the address, data, and control lines are in the high-impedance state, allowing them to be available to the external circuitry. HOLDA also goes into the high-impedance state when OFF is low.
MSC	O/Z	Microstate complete. MSC indicates completion of all software wait states. When two or more software wait states are enabled, the MSC pin goes active at the beginning of the first software wait state and goes inactive high at the beginning of the last software wait state. If connected to the READY input, MSC forces one external wait state after the last internal wait state is completed. MSC also goes into the high-impedance state when OFF is low.
IAQ	O/Z	Instruction acquisition signal. IAQ is asserted (active low) when there is an instruction address on the address bus and goes into the high-impedance state when OFF is low.
<b>TIMER SIGNALS</b>		
CLKOUT	O/Z	Clock output signal. CLKOUT can represent the machine-cycle rate of the CPU divided by 1, 2, 3, or 4 as configured in the bank-switching control register (BSCR). Following reset, CLKOUT represents the machine-cycle rate divided by 4.
CLKMD1‡ CLKMD2‡ CLKMD3‡	I	Clock mode select signals. CLKMD1–CLKMD3 allow the selection and configuration of different clock modes such as crystal, external clock, and PLL mode. The external CLKMD1–CLKMD3 pins are sampled to determine the desired clock generation mode while RS is low. Following reset, the clock generation mode can be reconfigured by writing to the internal clock mode register in software.
X2/CLKIN‡	I	Clock/oscillator input. If the internal oscillator is not being used, X2/CLKIN functions as the clock input. (This is revision-dependent, see Section 3.10 for additional information.)
X1	O	Output pin from the internal oscillator for the crystal. If the internal oscillator is not used, X1 should be left unconnected. X1 does not go into the high-impedance state when OFF is low. (This is revision-dependent, see Section 3.10 for additional information.)
TOUT	O/Z	Timer output. TOUT signals a pulse when the on-chip timer counts down past zero. The pulse is one CLKOUT cycle wide. TOUT also goes into the high-impedance state when OFF is low.
<b>MULTICHANNEL BUFFERED SERIAL PORT 0 (McBSP #0), MULTICHANNEL BUFFERED SERIAL PORT 1 (McBSP #1), AND MULTICHANNEL BUFFERED SERIAL PORT 2 (McBSP #2) SIGNALS</b>		
BCLKR0‡ BCLKR1‡ BCLKR2‡	I/O/Z	Receive clock input. BCLKR can be configured as an input or an output; it is configured as an input following reset. BCLKR serves as the serial shift clock for the buffered serial port receiver.
BDR0 BDR1 BDR2	I	Serial data receive input
BFSR0 BFSR1 BFSR2	I/O/Z	Frame synchronization pulse for receive input. BFSR can be configured as an input or an output; it is configured as an input following reset. The BFSR pulse initiates the receive data process over BDR.
BCLKX0‡ BCLKX1‡ BCLKX2‡	I/O/Z	Transmit clock. BCLKX serves as the serial shift clock for the McBSP transmitter. BCLKX can be configured as an input or an output, and is configured as an input following reset. BCLKX enters the high-impedance state when OFF goes low.
BDX0 BDX1 BDX2	O/Z	Serial data transmit output. BDX is placed in the high-impedance state when not transmitting, when RS is asserted, or when OFF is low.
BFSX0 BFSX1 BFSX2	I/O/Z	Frame synchronization pulse for transmit input/output. The BFSX pulse initiates the data transmit process over BDX. BFSX can be configured as an input or an output, and is configured as an input following reset. BFSX goes into the high-impedance state when OFF is low.

TERMINAL NAME	I/O†	DESCRIPTION
<b>HOST-PORT INTERFACE SIGNALS</b>		
HD0–HD7‡§	I/O/Z	Parallel bidirectional data bus. The HPI data bus is used by a host device bus to exchange information with the HPI registers. These pins can also be used as general-purpose I/O pins. HD0–HD7 is placed in the high-impedance state when not outputting data or when OFF is low. The HPI data bus includes bus holders to reduce the static power dissipation caused by floating, unused pins. When the HPI data bus is not being driven by the 5416, the bus holders keep the pins at the previous logic level. The HPI data bus holders are disabled at reset and can be enabled/disabled via the HBI bit of the BSCR. These pins also have Schmitt trigger inputs.
HCNTL0‡ HCNTL1‡	I	Control inputs. HCNTL0 and HCNTL1 select a host access to one of the three HPI registers. The control inputs have internal pullups that are only enabled when HPIENA = 0. These pins are not used when HPI16 = 1.
HBI1‡	I	Byte identification. HBI1 identifies the first or second byte of transfer. The HPI1 input has an internal pullup resistor that is only enabled when HPIENA = 0. This pin is not used when HPI16 = 1.
HCS‡	I	Chip select. HCS is the select input for the HPI and must be driven low during accesses. The chip select input has an internal pullup resistor that is only enabled when HPIENA = 0.
HDST1‡ HDST2‡	I	Data strobe. HDST1 and HDST2 are driven by the host read and write strobes to control the transfer. The strobe inputs have internal pullup resistors that are only enabled when HPIENA = 0.
HAS‡	I	Address strobe. Host with multiplexed address and data pins requires HAS to latch the address in the HPIA register. HAS input has an internal pullup resistor that is only enabled when HPIENA = 0.
HR/W‡	I	Read/write. HR/W controls the direction of the HPI transfer. HR/W has an internal pullup resistor that is only enabled when HPIENA = 0.
HRDY	O/Z	Ready output. HRDY goes into the high-impedance state when OFF is low. The ready output informs the host when the HPI is ready for the next transfer.
HINT	O/Z	Interrupt output. This output is used to interrupt the host. When the DSP is in reset, HINT is driven high. HINT goes into the high-impedance state when OFF is low. This pin is not used when HPI16 = 1.
HPIENA#	I	HPI module select. HPIENA must be tied to DVDD to have HPI selected. If HPIENA is left open or connected to ground, the HPI module is not selected, internal pullup for the HPI input pins are enabled, and the HPI data bus has holders set. HPIENA is provided with an internal pulldown resistor that is always active. HPIENA is sampled when RS goes high and is ignored until RS goes low again.
HPI16#	I	HPI16 mode selection
<b>SUPPLY PINS</b>		
CVSS	S	Ground. Dedicated ground for the core CPU
CVDD	S	+VDD. Dedicated power supply for the core CPU
DVSS	S	Ground. Dedicated ground for I/O pins
DVDD	S	+VDD. Dedicated power supply for I/O pins

TERMINAL NAME	I/O†	DESCRIPTION
<b>TEST PINS</b>		
TCK‡	I	IEEE standard 1149.1 test clock. TCK is normally a free-running clock signal with a 50% duty cycle. The changes on test access port (TAP) of input signals TMS and TDI are clocked into the TAP controller, instruction register, or selected test data register on the rising edge of TCK. Changes at the TAP output signal (TDO) occur on the falling edge of TCK.
TDI‡	I	IEEE standard 1149.1 test data input. Pin with internal pullup device. TDI is clocked into the selected register (instruction or data) on a rising edge of TCK.
TDO	O/Z	IEEE standard 1149.1 test data output. The contents of the selected register (instruction or data) are shifted out of TDO on the falling edge of TCK. TDO is in the high-impedance state except when the scanning of data is in progress. TDO also goes into the high-impedance state when OFF is low.
TMS‡	I	IEEE standard 1149.1 test mode select. Pin with internal pullup device. This serial control input is clocked into the TAP controller on the rising edge of TCK.
TRST#	I	IEEE standard 1149.1 test reset. TRST, when high, gives the IEEE standard 1149.1 scan system control of the operations of the device. If TRST is not connected or driven low, the device operates in its functional mode, and the IEEE standard 1149.1 signals are ignored. Pin with internal pulldown device.
EMU0	I/O/Z	Emulator 0 pin. When TRST is driven low, EMU0 must be high for activation of the OFF condition. When TRST is driven high, EMU0 is used as an interrupt to or from the emulator system and is defined as input/output by way of the IEEE standard 1149.1 scan system.
EMU1/OFF	I/O/Z	Emulator 1 pin/disable all outputs. When TRST is driven high, EMU1/OFF is used as an interrupt to or from the emulator system and is defined as input/output by way of IEEE standard 1149.1 scan system. When TRST is driven low, EMU1/OFF is configured as OFF. The EMU1/OFF signal, when active low, puts all output drivers into the high-impedance state. Note that OFF is used exclusively for testing and emulation purposes (not for multiprocessing applications). Therefore, for the OFF condition, the following apply: TRST = low EMU0 = high EMU1/OFF = low

† I = Input, O = Output, Z = High-impedance, S = Supply  
‡ These pins have Schmitt trigger inputs.  
§ This pin has an internal bus holder controlled by way of the BSCR register.  
¶ This pin has an internal pullup resistor.  
# This pin has an internal pulldown resistor.

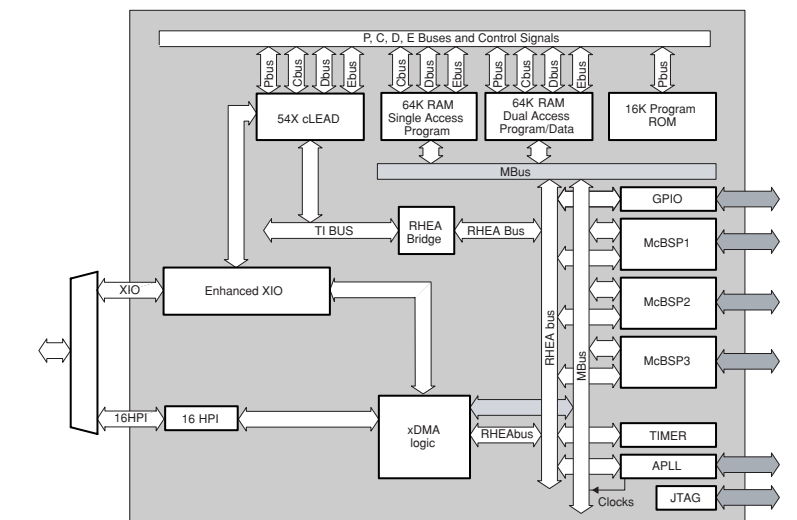

TMS320VC5416 Functional Block Diagram

# 10. EXPLODED VIEW AND PARTS LIST

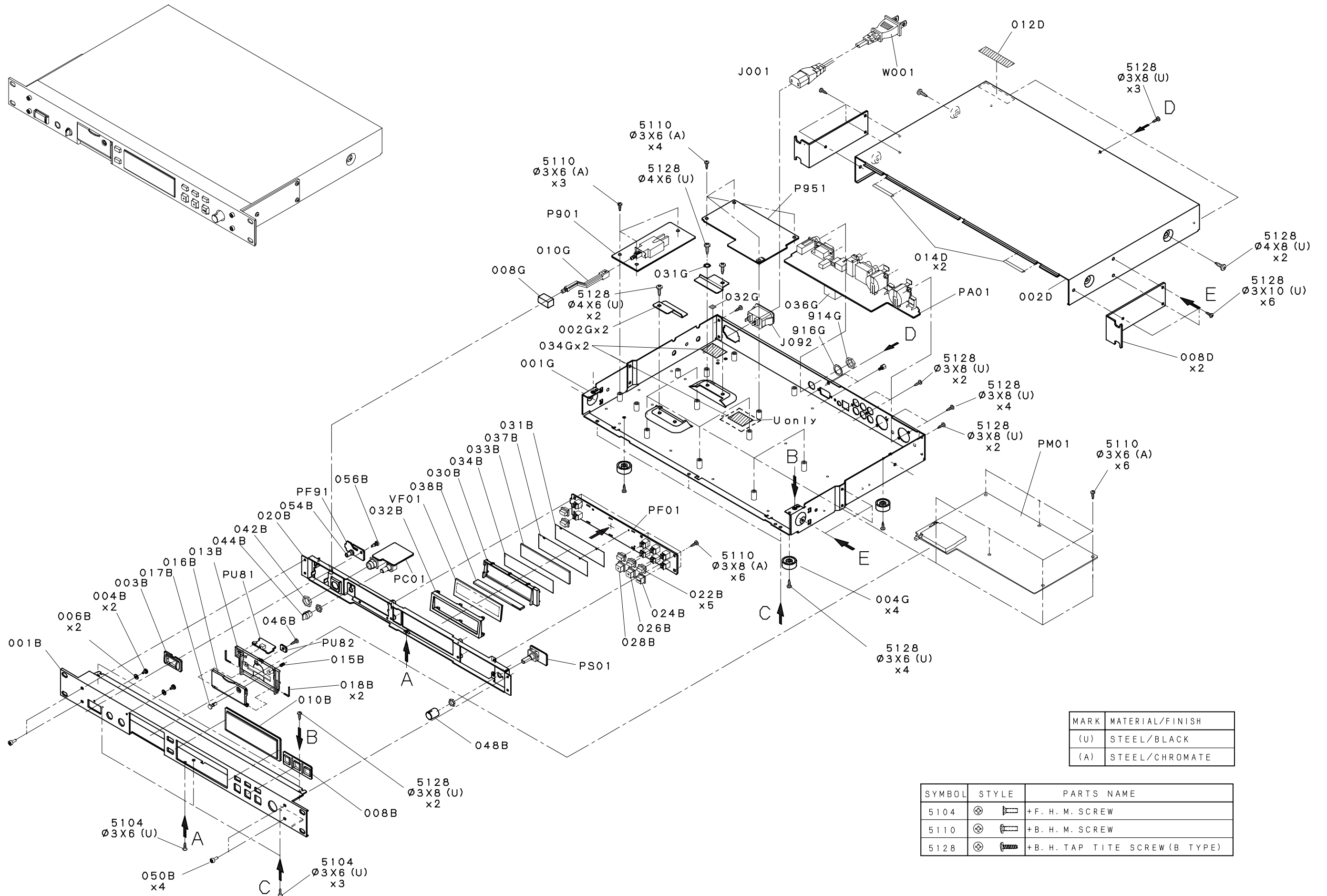

MARK	MATERIAL/FINISH
(U)	STEEL/BLACK
(A)	STEEL/CHROMATE

SYMBOL	STYLE	PARTS NAME
5104		+F. H. M. SCREW
5110		+B. H. M. SCREW
5128		+B. H. TAP TITE SCREW (B TYPE)

P.C.B. NAME	POS. NO.	VERS. COLOR	PART NO. (FOR EUR)	PART NO. (MJI)	PART NAME	DESCRIPTION
	001B	/F1B	nsp	49AS248010	FRONT PANEL	FRONT PANEL BLACK
	001B	/F1S	nsp	49AS248020	FRONT PANEL	FRONT PANEL SILVER
	001B	/N1B	49AS248010	49AS248010	FRONT PANEL	FRONT PANEL BLACK
	001B	/N1S	49AS248020	49AS248020	FRONT PANEL	FRONT PANEL SILVER
	001B	/U1B	nsp	49AS248010	FRONT PANEL	FRONT PANEL BLACK
	001B	/U1S	nsp	49AS248020	FRONT PANEL	FRONT PANEL SILVER
	003B		49AS259010	49AS259010	BUSHING	POWER BUTTON BUSH
	004B		238H355020	238H355020	LENS	LENS
	008B		49AS259020	49AS259020	BUSHING	BUTTON BUSH A(6PIECE)
	010B		49AS158010	49AS158010	WINDOW	WINDOW
	013B		49AS280500	49AS280500	HOUSING	CF HOUSING ASSY
	016B	/F1B	nsp	04AS162010	DOOR	CF CARD DOOR BLACK
	016B	/F1S	nsp	04AS162110	DOOR	CF CARD DOOR SILVER
	016B	/N1B	04AS162010	04AS162010	DOOR	CF CARD DOOR BLACK
	016B	/N1S	04AS162110	04AS162110	DOOR	CF CARD DOOR SILVER
	016B	/U1B	nsp	04AS162010	DOOR	CF CARD DOOR BLACK
	016B	/U1S	nsp	04AS162110	DOOR	CF CARD DOOR SILVER
	017B		2912259020	2912259020	BUSHING	DOOR BUSH
	018B		49AS112010	49AS112010	SHAFT	DOOR SHAFT
	022B		49AS270010	49AS270010	BUTTON	TACT KEY
	024B		49AS270110	49AS270110	BUTTON	PLAY BUTTON
	026B		49AS270210	49AS270210	BUTTON	STOP BUTTON
	028B		49AS270310	49AS270310	BUTTON	REC BUTTON
	033B		409S355300	409S355300	LENS	LCD LENS
	044B	/F1B	nsp	284T154310	KNOB	H.P VOL. KNOB BLACK
	044B	/F1S	nsp	284T154350	KNOB	H.P VOL. KNOB SILVER
	044B	/N1B	284T154310	284T154310	KNOB	H.P VOL. KNOB BLACK
	044B	/N1S	284T154350	284T154350	KNOB	H.P VOL. KNOB SILVER
	044B	/U1B	nsp	284T154310	KNOB	H.P VOL. KNOB BLACK
	044B	/U1S	nsp	284T154350	KNOB	H.P VOL. KNOB
	048B		388K154120	388K154120	KNOB	JOG
	050B	/F1S	nsp	02AS010010	SCREW	HEXA SOCKET HEAD SCREW SIL
	050B	/N1S	02AS010010	02AS010010	SCREW	HEXA SOCKET HEAD SCREW SIL
	050B	/U1S	nsp	02AS010010	SCREW	HEXA SOCKET HEAD SCREW SIL
	004G		416H057010	416H057010	LEG	LEG
	008G	/F1B	nsp	023J270020	BUTTON	POWER BUTTON BLACK
	008G	/F1S	nsp	023J270120	BUTTON	POWER BUTTON SILVER
	008G	/N1B	023J270020	023J270020	BUTTON	POWER BUTTON BLACK
	008G	/N1S	023J270120	023J270120	BUTTON	POWER BUTTON SILVER
	008G	/U1B	nsp	023J270020	BUTTON	POWER BUTTON BLACK
	008G	/U1S	nsp	023J270120	BUTTON	POWER BUTTON SILVER
	010G		416T121010	416T121010	LINK	LINK
	▲ J092	/F1B	nsp	YJ04002450	JACK	! 3P MAINS INLET M1910-D EMUDEN
	▲ J092	/F1S	nsp	YJ04002450	JACK	! 3P MAINS INLET M1910-D EMUDEN
	▲ J092	/N1B	YJ04002450	YJ04002450	JACK	! 3P MAINS INLET M1910-D EMUDEN
	▲ J092	/N1S	YJ04002450	YJ04002450	JACK	! 3P MAINS INLET M1910-D EMUDEN
	▲ J092	/U1B	nsp	YJ04002450	JACK	! 3P MAINS INLET M1910-D EMUDEN
	▲ J092	/U1S	nsp	YJ04002450	JACK	! 3P MAINS INLET M1910-D EMUDEN
	WA13		nsp	YU25110520	JUMPER LEAD	JU08-JF01 MAIN-LCD PCB
	WA14		nsp	YU19190520	JUMPER LEAD	JU06-JU09 MAIN-REAR(PA01)
<b>PACKING</b>						
	001T	/F1B	nsp	49AS851110	USER GUIDE	USER GUIDE JAPANESE
	001T	/F1S	nsp	49AS851110	USER GUIDE	USER GUIDE JAPANESE
	001T	/N1B	49AS851250	49AS851250	USER GUIDE	USER GUIDE U,N 4LANGUAGE
	001T	/N1S	49AS851250	49AS851250	USER GUIDE	USER GUIDE U,N 4LANGUAGE
	001T	/U1B	nsp	49AS851250	USER GUIDE	USER GUIDE U,N 4LANGUAGE
	001T	/U1S	nsp	49AS851250	USER GUIDE	USER GUIDE U,N 4LANGUAGE
	002T	/N1B	49AS851020	49AS851020	USER GUIDE	CD-ROM USER GUIDE
	002T	/N1S	49AS851020	49AS851020	USER GUIDE	CD-ROM USER GUIDE
	002T	/U1B	nsp	49AS851020	USER GUIDE	CD-ROM USER GUIDE
	002T	/U1S	nsp	49AS851020	USER GUIDE	CD-ROM USER GUIDE
	▲ W001	/F1B	nsp	ZC01801070	MAINS CORD	! MAINS POWER CABLE 125V 7A
	▲ W001	/F1S	nsp	ZC01801070	MAINS CORD	! MAINS POWER CABLE 125V 7A
	▲ W001	/N1B	ZC02003190	ZC02003190	MAINS CORD	# MAINS CORD 3P FOR N 10A 250V AC
	▲ W001	/N1S	ZC02003190	ZC02003190	MAINS CORD	# MAINS CORD 3P FOR N 10A 250V AC
	▲ W001	/U1B	nsp	ZC02002180	MAINS CORD	# MAINS CORD 3P 10A 125V NM U KAW
	▲ W001	/U1S	nsp	ZC02002180	MAINS CORD	# MAINS CORD 3P 10A 125V NM U KAW
	017Z		2912259020	2912259020	BUSHING	DOOR HOLE BUSH

NOTE : "nsp" PARTS IS LISTED FOR REFERENCE ONLY, MARANTZ WILL NOT SUPPLY THESE PARTS.

P.C.B. NAME	POS. NO.	VERS. COLOR	PART NO. (FOR EUR)	PART NO. (MJI)	PART NAME	DESCRIPTION
<b>NOT STANDARD SPARE PARTS</b>						
	002S		nsp	49AS801010	PACKING CASE	PKG
	004S		nsp	49AS809010	CUSHION	CUSHION
	002D		nsp	14AS257030	LID	LID
	008D	/F1B	nsp	49AS253010	HANDLE	HANDLE BLACK
	008D	/F1S	nsp	49AS253010	HANDLE	HANDLE BLACK
	008D	/N1B	nsp	49AS253010	HANDLE	HANDLE BLACK
	008D	/N1S	nsp	49AS253010	HANDLE	HANDLE BLACK
	008D	/U1B	nsp	49AS253010	HANDLE	HANDLE BLACK
	008D	/U1S	nsp	49AS253010	HANDLE	HANDLE BLACK

NOTE : "nsp" PARTS IS LISTED FOR REFERENCE ONLY, MARANTZ WILL NOT SUPPLY THESE PARTS.

# 11. ELECTRICAL PARTS LIST

## ASSIGNMENT OF COMMON PARTS CODES.

### RESISTORS

R\*\*\*: 1) GD05xxx140, Carbon film fixed resistor, ±5% 1/4W

R\*\*\*: 2) GD05xxx160, Carbon film fixed resistor, ±5% 1/6W

① Resistance value

Examples ;

① Resistance value

0.1 Ω .... 001    10 Ω .... 100    1 kΩ .... 102    100 kΩ .... 104  
 0.5 Ω .... 005    18 Ω .... 180    2.7 kΩ .... 272    680 kΩ .... 684  
 1 Ω .... 010    100 Ω .... 101    10 kΩ .... 103    1 MΩ .... 105  
 6.8 Ω .... 068    390 Ω .... 391    22 kΩ .... 223    4.7 MΩ .... 475

Note : Please distinguish 1/4W from 1/6W by the shape of parts used actually.

### CAPACITORS

C\*\*\*: CERAMIC CAP.

3) DD1xxx370, Ceramic capacitor  
 Disc type  
 Temp.coeff.P350 ~N1000, 50V  
 ② Capacity value  
 ③ Tolerance

Examples ;

② Tolerance (Capacity deviation)

±0.25 pF .... 0  
 ±0.5 pF .... 1  
 ±5% .... 5

\* Tolerance of COMMON PARTS handled here are as follows :

0.5 pF ~ 5 pF .... ±0.25 pF  
 6 pF ~ 10 pF .... ±0.5 pF  
 12 pF ~ 560 pF .... ±5%

③ Capacity value

0.5 pF .... 005    3 pF .... 030    100 pF .... 101  
 1 pF .... 010    10 pF .... 100    220 pF .... 221  
 1.5 pF .... 015    47 pF .... 470    560 pF .... 561

C\*\*\*: CERAMIC CAP.

4) DK16xxx300, High dielectric constant ceramic capacitor  
 Disc type  
 Temp.chara. 2B4, 50V  
 ④ Capacity value

Examples ;

④ Capacity value

100 pF .... 101    1000 pF .... 102    10000 pF .... 103  
 470 pF .... 471    2200 pF .... 222

C\*\*\*: 5) ELECTROLY CAP. (  $\text{ZZ}$  ), 6) FILM CAP. (  $\text{ZZ}$  )

5) EAxxx10, Electrolytic capacitor  
 One-way lead type, Tolerance ±20%  
 ⑤ Capacity value  
 ⑥ Working voltage

Examples ;

⑤ Capacity value

0.1 μF .... 104    4.7 μF .... 475    100 μF .... 107  
 0.33 μF .... 334    10 μF .... 106    330 μF .... 337  
 1 μF .... 105    22 μF .... 226    1100 μF .... 118  
 2200 μF .... 228

⑥ Working voltage

6.3V .... 006    25V .... 025  
 10V .... 010    35V .... 035  
 16V .... 016    50V .... 050

6) DF15xxx350 → Plastic film capacitor  
 DF15xxx310 → One-way type, Mylar ±5% 50V  
 DF16xxx310 → Plastic film capacitor  
 One-way type, Mylar ±10% 50V  
 ⑦ Capacity value

Examples ;

⑦ Capacity value

0.001 μF (1000 pF) ..... 102    0.1 μF .... 104  
 0.0018 μF ..... 182    0.56 μF .... 564  
 0.01 μF ..... 103    1 μF .... 105  
 0.015 μF ..... 153

**NOTE** : 1) The above CODES ( R\*\*\*, R\*\*\*, C\*\*\*, C\*\*\* and C\*\*\* ) are omitted on the schematic diagram in some case.  
 2) On the occasion, be confirmed the common parts on the parts list.  
 3) Refer to "Common Parts List" for the other common parts (RI05, DD4, DK4).

## NOTE ON SAFETY FOR FUSIBLE RESISTOR :

The suppliers and their type numbers of fusible resistors are as follows;

1. KOA Corporation

Part No. (MJI)	Type No. (KOA)	Description
NH05xxx140	RF25SxxxxΩJ	(±5% 1/4W)
NH05xxx120	RF50SxxxxΩJ	(±5% 1/2W)
NH85xxx110	RF73B2AxxxxΩJ	(±5% 1/10W)
NH95xxx140	RF73B2ExxxxΩJ	(±5% 1/4W)

\* Resistance value (0.1 Ω - 10 kΩ)

2. Matsushita Electronic Components Co., Ltd

Part No. (MJI)	Type No. (MEC)	Description
NF05xxx140	ERD-2FCJxxx	(±5% 1/4W)
RF05xxx140		
NF02xxx140	ERD-2FCGxxx	(±2% 1/4W)
RF02xxx140		

\* Resistance value

Examples ;

\* Resistance value



0.1 Ω .... 001    10 Ω .... 100    1 kΩ .... 102    100 kΩ .... 104  
 0.5 Ω .... 005    18 Ω .... 180    2.7 kΩ .... 272    680 kΩ .... 684  
 1 Ω .... 010    100 Ω .... 101    10 kΩ .... 103    1 MΩ .... 105  
 6.8 Ω .... 068    390 Ω .... 391    22 kΩ .... 223    4.7 MΩ .... 475

ABBREVIATION AND MARKS		
ANT. : ANTENNA	BATT. : BATTERY	
CAP. : CAPACITOR	CER. : CERAMIC	
CONN. : CONNECTING	DIG. : DIGITAL	
HP : HEADPHONE	MIC. : MICROPHONE	
μ-PRO : MICROPROCESSOR	REC. : RECORDING	
RES. : RESISTOR	SPK : SPEAKER	
SW : SWITCH	TRANSF. : TRANSFORMER	
TRIM. : TRIMMING	TRS. : TRANSISTOR	
VAR. : VARIABLE	X'TAL : CRYSTAL	

## NOTE ON FUSE :

Regarding to all parts of parts code **FS20xxx2xx**, replace only with Wickmann-Werke GmbH, Type 372 non glass type fuse.

## NOTE ON SAFETY :

Symbol  Fire or electrical shock hazard. Only original parts should be used to replaced any part marked with symbol . Any other component substitution (other than original type), may increase risk of fire or electrical shock hazard.

## 安全上の注意 :

 がついている部品は、安全上重要な部品です。必ず指定されている部品番号の部品を使用して下さい。

P.C.B. NAME	POS. NO.	VERS. COLOR	PART NO. (FOR EUR)	PART NO. (MJI)	PART NAME	DESCRIPTION
P901	▲ C991		nsp	DK17103910	CERAMIC CAP.	# DE1607-1F 103M-KH
P901	▲ S991		SP02012310	SP02012310	PUSH SWITCH	# SDDFE10100 POWER SWITCH
P951	▲ C951		DF17224570	DF17224570	FILM CAP.	# ECQU2A224ML 0.22μF/250V
P951	C953		EA12740080	EA12740080	ELECT. CAP.	120μF/400V YOKOOKI TYPE
P951	C954		nsp	DK96104300	CERAMIC CAP.	C1608X7R1H104K
P951	C955		nsp	OA47602520	ELECT. CAP.	47 μF M 25V RA-2
P951	C957		nsp	DK17681520	CERAMIC CAP.	DE0910 B 681K -KX 680PF 250V
P951	C958		nsp	DK17471520	CERAMIC CAP.	DE0910 B 471K -KX 470PF 250V
P951	C973		EA47703510	EA47703510	ELECT. CAP.	470μF/ 35V
P951	C974		nsp	DK96104300	CERAMIC CAP.	C1608X7R1H104K
P951	C975		nsp	OA47603520	ELECT. CAP.	47μF M 35V RA-2
P951	C976		nsp	DK96104300	CERAMIC CAP.	C1608X7R1H104K
P951	D953		nsp	HD20031290	DIODE	S1WB(A)60 30A 600V
P951	D957		HV00001290	HV00001290	VARISTOR	ST03D-170 TRANKILLER
P951	D959		HZ21005000	HZ21005000	CHIP DIODE	1SS301,DAN202U UMT TYPE
P951	D971		HE10010080	HE10010080	DIODE	FMB-26L
P951	▲ F951		FS20160200	FS20160200	FUSE	# FUSE 1.6A 250V SEMKO VDE
P951	▲ F971		FS20080200	FS20080200	FUSE	# FUSE 0.8A 250V SEMKO VDE
P951	▲ G951		HV00033020	HV00033020	VARISTOR	# ERZV07D471
P951	▲ L951		LC22260130	LC22260130	CHOKE COIL	# 22MH X2 LINE FILTER
P951	L971		LU83103030	LU83103030	CHIP	CDRH5D28 10μH +- 30%
P951	L972		LC11040190	LC11040190	CHOKE COIL	100μH COM.MODE COIL
P951	Q951		HC10177020	HC10177020	IC	MIP2E5DMY
P951	Q952		HW10032320	HW10032320	PHOTO UNIT	PC-123F2 PHOTO CUPLER
P951	Q953		BA20021210	BA20021210	SEMICON.COMP	DTC144EC (ROHM)
P951	Q972		HC33036590	HC33036590	IC REG.	TL431CZ PROG.VOLTAGE REFERENCE
P951	R951		RC05105010	RC05105010	RESISTOR	1M OHM +-5% 1W RCR60 L15
P951	R953		RI05150140	RI05150140	CHIP RESISTOR	15 OHM +- 5% 1/4W
P951	R954		nsp	NN05560610	CHIP RESISTOR	56 OHM +- 5% 1/16W
P951	R955		nsp	NN05560610	CHIP RESISTOR	56 OHM +- 5% 1/16W
P951	R971		RI05330120	RI05330120	CHIP RESISTOR	33 OHM +- 5% 1/2W
P951	R972		nsp	NN05150610	CHIP RESISTOR	15 OHM +- 5% 1/16W
P951	R973		nsp	NN05333610	CHIP RESISTOR	33K OHM +- 5% 1/16W
P951	R974		nsp	NN05183610	CHIP RESISTOR	18K OHM +- 5% 1/16W
P951	R975		nsp	NN05562610	CHIP RESISTOR	5.6K OHM +- 5% 1/16W
P951	R977		nsp	NN05223610	CHIP RESISTOR	22K OHM +- 5% 1/16W
P951	T951		TS12900090	TS12900090	TRANSF.	ER28 SW TRANS
PA01	C251		nsp	DD95470300	CERAMIC CAP.	47 PF +- 5% CG 50V GR39
PA01	C252		nsp	DD95470300	CERAMIC CAP.	47 PF +- 5% CG 50V GR39
PA01	C253		nsp	OA47602520	ELECT. CAP.	47 μF M 25V RA-2
PA01	C254		nsp	OA47602520	ELECT. CAP.	47 μF M 25V RA-2
PA01	C255		nsp	DD95470300	CERAMIC CAP.	47 PF +- 5% CG 50V GR39
PA01	C256		nsp	DD95470300	CERAMIC CAP.	47 PF +- 5% CG 50V GR39
PA01	C257		nsp	OA47602520	ELECT. CAP.	47 μF M 25V RA-2
PA01	C258		nsp	OA47602520	ELECT. CAP.	47 μF M 25V RA-2
PA01	C259		nsp	DK96104300	CERAMIC CAP.	C1608X7R1H104K
PA01	C260		nsp	DK96104300	CERAMIC CAP.	C1608X7R1H104K
PA01	C402		nsp	DK96104300	CERAMIC CAP.	C1608X7R1H104K
PA01	C405		nsp	DK96104300	CERAMIC CAP.	C1608X7R1H104K
PA01	C410		nsp	DD95221300	CERAMIC CAP.	220 PF +- 5% CG 50V GR39
PA01	C411		nsp	DK96104300	CERAMIC CAP.	C1608X7R1H104K
PA01	C412		nsp	DK98105200	CERAMIC CAP.	1μF 10V F
PA01	CA01		nsp	DD95470300	CERAMIC CAP.	47 PF +- 5% CG 50V GR39
PA01	CA02		nsp	DD95470300	CERAMIC CAP.	47 PF +- 5% CG 50V GR39
PA01	CA03		nsp	DD95470300	CERAMIC CAP.	47 PF +- 5% CG 50V GR39
PA01	CA04		nsp	DD95470300	CERAMIC CAP.	47 PF +- 5% CG 50V GR39
PA01	CA05		nsp	DD95470300	CERAMIC CAP.	47 PF +- 5% CG 50V GR39
PA01	CA06		nsp	DD95470300	CERAMIC CAP.	47 PF +- 5% CG 50V GR39
PA01	CA07		nsp	DD95470300	CERAMIC CAP.	47 PF +- 5% CG 50V GR39
PA01	CA08		nsp	DD95470300	CERAMIC CAP.	47 PF +- 5% CG 50V GR39
PA01	CA09		nsp	DD95470300	CERAMIC CAP.	47 PF +- 5% CG 50V GR39
PA01	CA10		nsp	DD95470300	CERAMIC CAP.	47 PF +- 5% CG 50V GR39
PA01	CA11		nsp	OA47602520	ELECT. CAP.	47 μF M 25V RA-2
PA01	CA12		nsp	OA47602520	ELECT. CAP.	47 μF M 25V RA-2
PA01	CA13		nsp	OA47602520	ELECT. CAP.	47 μF M 25V RA-2
PA01	CA14		nsp	OA47602520	ELECT. CAP.	47 μF M 25V RA-2
PA01	CA15		nsp	DD95470300	CERAMIC CAP.	47 PF +- 5% CG 50V GR39
PA01	CA16		nsp	DD95470300	CERAMIC CAP.	47 PF +- 5% CG 50V GR39
PA01	CA17		nsp	DD95470300	CERAMIC CAP.	47 PF +- 5% CG 50V GR39
PA01	CA18		nsp	DD95470300	CERAMIC CAP.	47 PF +- 5% CG 50V GR39

NOTE : "nsp" PARTS IS LISTED FOR REFERENCE ONLY, MARANTZ WILL NOT SUPPLY THESE PARTS.



P.C.B. NAME	POS. NO.	VERS. COLOR	PART NO. (FOR EUR)	PART NO. (MJI)	PART NAME	DESCRIPTION
PA01	CA19		nsp	DK96104300	CERAMIC CAP.	C1608X7R1H104K
PA01	CA20		nsp	DK96104300	CERAMIC CAP.	C1608X7R1H104K
PA01	CA21		nsp	DK96104300	CERAMIC CAP.	C1608X7R1H104K
PA01	CA22		nsp	DK96104300	CERAMIC CAP.	C1608X7R1H104K
PA01	CA23		nsp	DD95470300	CERAMIC CAP.	47 PF +- 5% CG 50V GR39
PA01	CA24		nsp	DD95470300	CERAMIC CAP.	47 PF +- 5% CG 50V GR39
PA01	CA25		nsp	DK96104300	CERAMIC CAP.	C1608X7R1H104K
PA01	CA26		nsp	DK96104300	CERAMIC CAP.	C1608X7R1H104K
PA01	CA27		nsp	OA47602520	ELECT. CAP.	47 µF M 25V RA-2
PA01	CA28		nsp	OA47602520	ELECT. CAP.	47 µF M 25V RA-2
PA01	CA31		nsp	NN05000610	CHIP RESISTOR	0 OHM +- 5% 1/16W
PA01	CA32		nsp	NN05000610	CHIP RESISTOR	0 OHM +- 5% 1/16W
PA01	CA33		nsp	OA10701620	ELECT. CAP.	100 µF M 16V RA-2
PA01	CA34		nsp	OA10701620	ELECT. CAP.	100 µF M 16V RA-2
PA01	CM91		nsp	DK96103300	CERAMIC CAP.	0.01µF +-10% 50V C1608JB1H103K
PA01	CM92		nsp	DD95221300	CERAMIC CAP.	220 PF +- 5% CG 50V GR39
PA01	CR01		nsp	DK96103300	CERAMIC CAP.	0.01µF +-10% 50V C1608JB1H103K
PA01	CR03		nsp	DK96103300	CERAMIC CAP.	0.01µF +-10% 50V C1608JB1H103K
PA01	CR05		nsp	DK96103300	CERAMIC CAP.	0.01µF +-10% 50V C1608JB1H103K
PA01	CR07		nsp	DK96103300	CERAMIC CAP.	0.01µF +-10% 50V C1608JB1H103K
PA01	CR09		nsp	DK96103300	CERAMIC CAP.	0.01µF +-10% 50V C1608JB1H103K
PA01	CR11		nsp	DK96103300	CERAMIC CAP.	0.01µF +-10% 50V C1608JB1H103K
PA01	CR13		nsp	DD95101300	CERAMIC CAP.	100 PF +- 5% CG 50V GR39
PA01	CR14		nsp	DD95101300	CERAMIC CAP.	100 PF +- 5% CG 50V GR39
PA01	CR15		nsp	DD95101300	CERAMIC CAP.	100 PF +- 5% CG 50V GR39
PA01	CR16		nsp	DD95101300	CERAMIC CAP.	100 PF +- 5% CG 50V GR39
PA01	CR17		nsp	DK96103300	CERAMIC CAP.	0.01µF +-10% 50V C1608JB1H103K
PA01	CR21		nsp	DD95220300	CERAMIC CAP.	22 PF +- 5% CG 50V GR39
PA01	CX81		nsp	DD95470300	CERAMIC CAP.	47 PF +- 5% CG 50V GR39
PA01	CX82		nsp	DD95470300	CERAMIC CAP.	47 PF +- 5% CG 50V GR39
PA01	CX83		nsp	DD95470300	CERAMIC CAP.	47 PF +- 5% CG 50V GR39
PA01	CX84		nsp	DD95470300	CERAMIC CAP.	47 PF +- 5% CG 50V GR39
PA01	J201		YT02041040	YT02041040	TERMINAL	14X14 RA 2L4P W/R NI FRNT-GND
PA01	J401		YT02021230	YT02021230	TERMINAL	14X14 RA 2L2P BLK NI FLM-GND
PA01	JA01		YJ01004340	YJ01004340	JACK	NC3FAH2 4P CANON TYPE HOLZ
PA01	JA02		YJ01004340	YJ01004340	JACK	NC3FAH2 4P CANON TYPE HOLZ
PA01	JM91		YJ01003050	YJ01003050	JACK	O3.5 HEAD PHONE JACK HLJ0521
PA01	JM92		YJ01004520	YJ01004520	JACK	4P MINI JACK HSJ 1637-010512
PA01	JR01		YT02090160	YT02090160	TERMINAL	D-SUB 9PIN F
PA01	JX81		YJ90014590	YJ90014590	JACK	USB CONNECTOR CMS1410
PA01	L251		FN31010030	FN31010030	EMI FILTER	BLM11B102S 1608 EMIFILTER
PA01	L252		FN31010030	FN31010030	EMI FILTER	BLM11B102S 1608 EMIFILTER
PA01	L253		FN31010030	FN31010030	EMI FILTER	BLM11B102S 1608 EMIFILTER
PA01	L254		FN31010030	FN31010030	EMI FILTER	BLM11B102S 1608 EMIFILTER
PA01	L401		FN31010030	FN31010030	EMI FILTER	BLM11B102S 1608 EMIFILTER
PA01	L403		TP41042010	TP41042010	TRANSF.	PULS TRANS FOR CD
PA01	L404		FN31010030	FN31010030	EMI FILTER	BLM11B102S 1608 EMIFILTER
PA01	LA01		FC90020110	FC90020110	FERRITE CORE	47 PF +- 5% CG 50V GR39
PA01	LA02		FC90020110	FC90020110	FERRITE CORE	47 PF +- 5% CG 50V GR39
PA01	LA03		FC90020110	FC90020110	FERRITE CORE	47 PF +- 5% CG 50V GR39
PA01	LA04		FC90020110	FC90020110	FERRITE CORE	47 PF +- 5% CG 50V GR39
PA01	LM91		FN31010030	FN31010030	EMI FILTER	BLM11B102S 1608 EMIFILTER
PA01	LX81		FC90020110	FC90020110	FERRITE CORE	BLM11B601S CHIP FERRITE
PA01	LX82		FC90020110	FC90020110	FERRITE CORE	BLM11B601S CHIP FERRITE
PA01	Q251		HC10102090	HC10102090	IC	NJM2068M TAPING
PA01	QA01		HC10102090	HC10102090	IC	NJM2068M TAPING
PA01	QA02		HC10102090	HC10102090	IC	NJM2068M TAPING
PA01	QA03		HC10102090	HC10102090	IC	NJM2068M TAPING
PA01	QR01		HC10292060	HC10292060	IC	UPD4721GS-GJG IC RS232C
PA01	R251		nsp	NN05473610	CHIP RESISTOR	47K OHM +- 5% 1/16W
PA01	R252		nsp	NN05473610	CHIP RESISTOR	47K OHM +- 5% 1/16W
PA01	R253		nsp	NN05473610	CHIP RESISTOR	47K OHM +- 5% 1/16W
PA01	R254		nsp	NN05473610	CHIP RESISTOR	47K OHM +- 5% 1/16W
PA01	R257		nsp	NN05000610	CHIP RESISTOR	0 OHM +- 5% 1/16W
PA01	R258		nsp	NN05000610	CHIP RESISTOR	0 OHM +- 5% 1/16W
PA01	R259		nsp	NN05473610	CHIP RESISTOR	47K OHM +- 5% 1/16W
PA01	R260		nsp	NN05473610	CHIP RESISTOR	47K OHM +- 5% 1/16W
PA01	R401		nsp	NN05000610	CHIP RESISTOR	0 OHM +- 5% 1/16W
PA01	R402		nsp	NN05750610	CHIP RESISTOR	75 OHM +-5% 1/16W
PA01	R405		nsp	NN05000610	CHIP RESISTOR	0 OHM +- 5% 1/16W

NOTE : "nsp" PARTS IS LISTED FOR REFERENCE ONLY, MARANTZ WILL NOT SUPPLY THESE PARTS.

P.C.B. NAME	POS. NO.	VERS. COLOR	PART NO. (FOR EUR)	PART NO. (MJI)	PART NAME	DESCRIPTION
PA01	R408		nsp	NN05221610	CHIP RESISTOR	220 OHM +- 5% 1/16W
PA01	R409		nsp	NN05102610	CHIP RESISTOR	1K OHM +- 5% 1/16W
PA01	R410		nsp	NN05470610	CHIP RESISTOR	47 OHM +- 5% 1/16W
PA01	R411		nsp	NN05750610	CHIP RESISTOR	75 OHM +-5% 1/16W
PA01	R412		nsp	NN05000610	CHIP RESISTOR	0 OHM +- 5% 1/16W
PA01	RA01		nsp	NN05104610	CHIP RESISTOR	100K OHM +- 5% 1/16W
PA01	RA02		nsp	NN05104610	CHIP RESISTOR	100K OHM +- 5% 1/16W
PA01	RA03		nsp	NN05104610	CHIP RESISTOR	100K OHM +- 5% 1/16W
PA01	RA04		nsp	NN05104610	CHIP RESISTOR	100K OHM +- 5% 1/16W
PA01	RA15		nsp	NN05333610	CHIP RESISTOR	33K OHM +- 5% 1/16W
PA01	RA16		nsp	NN05333610	CHIP RESISTOR	33K OHM +- 5% 1/16W
PA01	RA17		nsp	NN05333610	CHIP RESISTOR	33K OHM +- 5% 1/16W
PA01	RA18		nsp	NN05333610	CHIP RESISTOR	33K OHM +- 5% 1/16W
PA01	RA19		RK02031120	RK02031120	VARIABLE RESIST	RK09K111 LM1=9.5MM
PA01	RA20		RK02031120	RK02031120	VARIABLE RESIST	RK09K111 LM1=9.5MM
PA01	RA21		nsp	NN05101610	CHIP RESISTOR	100 OHM +- 5% 1/16W
PA01	RA22		nsp	NN05101610	CHIP RESISTOR	100 OHM +- 5% 1/16W
PA01	RA23		nsp	NN05101610	CHIP RESISTOR	100 OHM +- 5% 1/16W
PA01	RA24		nsp	NN05101610	CHIP RESISTOR	100 OHM +- 5% 1/16W
PA01	RA25		nsp	NN05104610	CHIP RESISTOR	100K OHM +- 5% 1/16W
PA01	RA26		nsp	NN05104610	CHIP RESISTOR	100K OHM +- 5% 1/16W
PA01	RA27		nsp	NN05104610	CHIP RESISTOR	100K OHM +- 5% 1/16W
PA01	RA28		nsp	NN05104610	CHIP RESISTOR	100K OHM +- 5% 1/16W
PA01	RA29		nsp	NN05472610	CHIP RESISTOR	4.7K OHM +- 5% 1/16W
PA01	RA30		nsp	NN05472610	CHIP RESISTOR	4.7K OHM +- 5% 1/16W
PA01	RA31		nsp	NN05392610	CHIP RESISTOR	3.9K OHM +- 5% 1/16W
PA01	RA32		nsp	NN05392610	CHIP RESISTOR	3.9K OHM +- 5% 1/16W
PA01	RA33		nsp	NN05472610	CHIP RESISTOR	4.7K OHM +- 5% 1/16W
PA01	RA34		nsp	NN05472610	CHIP RESISTOR	4.7K OHM +- 5% 1/16W
PA01	RA35		nsp	NN05472610	CHIP RESISTOR	4.7K OHM +- 5% 1/16W
PA01	RA36		nsp	NN05472610	CHIP RESISTOR	4.7K OHM +- 5% 1/16W
PA01	RA37		nsp	NN05472610	CHIP RESISTOR	4.7K OHM +- 5% 1/16W
PA01	RA38		nsp	NN05472610	CHIP RESISTOR	4.7K OHM +- 5% 1/16W
PA01	RA39		nsp	NN05472610	CHIP RESISTOR	4.7K OHM +- 5% 1/16W
PA01	RA40		nsp	NN05472610	CHIP RESISTOR	4.7K OHM +- 5% 1/16W
PA01	RA41		nsp	NN05472610	CHIP RESISTOR	4.7K OHM +- 5% 1/16W
PA01	RA42		nsp	NN05472610	CHIP RESISTOR	4.7K OHM +- 5% 1/16W
PA01	RA43		nsp	NN05472610	CHIP RESISTOR	4.7K OHM +- 5% 1/16W
PA01	RA44		nsp	NN05472610	CHIP RESISTOR	4.7K OHM +- 5% 1/16W
PA01	RA45		nsp	NN05104610	CHIP RESISTOR	100K OHM +- 5% 1/16W
PA01	RA46		nsp	NN05104610	CHIP RESISTOR	100K OHM +- 5% 1/16W
PA01	RA51		nsp	NN05331610	CHIP RESISTOR	330 OHM +- 5% 1/16W
PA01	RA52		nsp	NN05331610	CHIP RESISTOR	330 OHM +- 5% 1/16W
PA01	RA53		nsp	NN05151610	CHIP RESISTOR	150 OHM +- 5% 1/16W
PA01	RA54		nsp	NN05151610	CHIP RESISTOR	150 OHM +- 5% 1/16W
PA01	RA61		nsp	NN05223610	CHIP RESISTOR	22K OHM +- 5% 1/16W
PA01	RA62		nsp	NN05223610	CHIP RESISTOR	22K OHM +- 5% 1/16W
PA01	RA63		nsp	NN05223610	CHIP RESISTOR	22K OHM +- 5% 1/16W
PA01	RA64		nsp	NN05223610	CHIP RESISTOR	22K OHM +- 5% 1/16W
PA01	RM91		nsp	NN05100610	CHIP RESISTOR	10 OHM +- 5% 1/16W
PA01	RM92		nsp	NN05101610	CHIP RESISTOR	100 OHM +- 5% 1/16W
PA01	RM93		nsp	NN05102610	CHIP RESISTOR	1K OHM +- 5% 1/16W
PA01	RM94		nsp	NN05000610	CHIP RESISTOR	0 OHM +- 5% 1/16W
PA01	RM95		nsp	NN05000610	CHIP RESISTOR	0 OHM +- 5% 1/16W
PA01	RM96		nsp	NN05473610	CHIP RESISTOR	47K OHM +- 5% 1/16W
PA01	RM99		NI05000110	NI05000110	CHIP RESISTOR	0 OHM +- 5% 1/10W
PA01	RM99		NI05000110	NI05000110	CHIP RESISTOR	0 OHM +- 5% 1/10W
PA01	RR01		nsp	NN05223610	CHIP RESISTOR	22K OHM +- 5% 1/16W
PA01	RR02		nsp	NN05223610	CHIP RESISTOR	22K OHM +- 5% 1/16W
PA01	RR03		nsp	NN05000610	CHIP RESISTOR	0 OHM +- 5% 1/16W
PA01	RR11		nsp	NN05101610	CHIP RESISTOR	100 OHM +- 5% 1/16W
PA01	RX81		nsp	NN05104610	CHIP RESISTOR	100K OHM +- 5% 1/16W
PA01	RX82		nsp	NN05154610	CHIP RESISTOR	150K OHM +- 5% 1/16W
PA01	SR01		SP02022320	SP02022320	PUSH SWITCH	PUSH SW (SPUJ191000) W/KNOB
PC01	CC01		nsp	OA47602520	ELECT. CAP.	47 µF M 25V RA-2
PC01	CC02		nsp	OA47602520	ELECT. CAP.	47 µF M 25V RA-2
PC01	CC03		nsp	DD95220300	CERAMIC CAP.	22 PF +- 5% CG 50V GR39
PC01	CC04		nsp	DD95220300	CERAMIC CAP.	22 PF +- 5% CG 50V GR39
PC01	CC07		nsp	DK96222300	CERAMIC CAP.	2200PF (GR39)
PC01	CC08		nsp	DK96222300	CERAMIC CAP.	2200PF (GR39)

NOTE : "nsp" PARTS IS LISTED FOR REFERENCE ONLY, MARANTZ WILL NOT SUPPLY THESE PARTS.

P.C.B. NAME	POS. NO.	VERS. COLOR	PART NO. (FOR EUR)	PART NO. (MJI)	PART NAME	DESCRIPTION
PC01	CC09		nsp	DD95470300	CERAMIC CAP.	47 PF +- 5% CG 50V GR39
PC01	CC10		nsp	DD95470300	CERAMIC CAP.	47 PF +- 5% CG 50V GR39
PC01	CC11		nsp	OA22701620	ELECT. CAP.	220 µF M 16V RA-2
PC01	CC12		nsp	OA22701620	ELECT. CAP.	220 µF M 16V RA-2
PC01	CC13		nsp	OA47602520	ELECT. CAP.	47 µF M 25V RA-2
PC01	CC14		nsp	OA47602520	ELECT. CAP.	47 µF M 25V RA-2
PC01	CC15		nsp	DK96104300	CERAMIC CAP.	C1608X7R1H104K
PC01	CC16		nsp	DK96104300	CERAMIC CAP.	C1608X7R1H104K
PC01	CC21		nsp	DK96104300	CERAMIC CAP.	C1608X7R1H104K
PC01	CC22		nsp	DK96104300	CERAMIC CAP.	C1608X7R1H104K
PC01	JC02		YJ01003280	YJ01003280	JACK	YKB21-5009 6.3MM ST PHONE JACK
PC01	LC01		FN31010030	FN31010030	EMI FILTER	BLM11B102S 1608 EMIFILTER
PC01	LC02		FN31010030	FN31010030	EMI FILTER	BLM11B102S 1608 EMIFILTER
PC01	LC03		FN31010030	FN31010030	EMI FILTER	BLM11B102S 1608 EMIFILTER
PC01	LC04		FN31010030	FN31010030	EMI FILTER	BLM11B102S 1608 EMIFILTER
PC01	LC21		FN31010030	FN31010030	EMI FILTER	BLM11B102S 1608 EMIFILTER
PC01	QC01		HC10045090	HC10045090	IC	NJM-4556MB
PC01	QC03		BA20080210	BA20080210	SEMICON.COMP	DTC323TU
PC01	QC04		BA20080210	BA20080210	SEMICON.COMP	DTC323TU
PC01	QC05		BA20080210	BA20080210	SEMICON.COMP	DTC323TU
PC01	QC06		BA20080210	BA20080210	SEMICON.COMP	DTC323TU
PC01	RC01		RM01031250	RM01031250	VARIABLE RESIST	RK0971220 10K A (D-CUT REV)
PC01	RC03		nsp	NN05223610	CHIP RESISTOR	22K OHM +- 5% 1/16W
PC01	RC04		nsp	NN05223610	CHIP RESISTOR	22K OHM +- 5% 1/16W
PC01	RC05		nsp	NN05473610	CHIP RESISTOR	47K OHM +- 5% 1/16W
PC01	RC06		nsp	NN05473610	CHIP RESISTOR	47K OHM +- 5% 1/16W
PC01	RC07		nsp	NN05153610	CHIP RESISTOR	15K OHM +- 5% 1/16W
PC01	RC08		nsp	NN05153610	CHIP RESISTOR	15K OHM +- 5% 1/16W
PC01	RC09		nsp	NN05680610	CHIP RESISTOR	68 OHM +- 5% 1/16W
PC01	RC10		nsp	NN05680610	CHIP RESISTOR	68 OHM +- 5% 1/16W
PC01	RC11		nsp	NN05820610	CHIP RESISTOR	82 OHM +- 5% 1/16W
PC01	RC12		nsp	NN05820610	CHIP RESISTOR	82 OHM +- 5% 1/16W
PC01	RC13		nsp	NN05000610	CHIP RESISTOR	0 OHM +- 5% 1/16W
PC01	RC14		nsp	NN05000610	CHIP RESISTOR	0 OHM +- 5% 1/16W
PC01	RC17		nsp	NN05473610	CHIP RESISTOR	47K OHM +- 5% 1/16W
PC01	RC18		nsp	NN05473610	CHIP RESISTOR	47K OHM +- 5% 1/16W
PF01	CF03		nsp	DK96104300	CERAMIC CAP.	C1608X7R1H104K
PF01	CF04		EY47501670	EY47501670	TANTL.CAP CHIP	4.7µF/ 16V
PF01	CF05		EY47501670	EY47501670	TANTL.CAP CHIP	4.7µF/ 16V
PF01	CF06		EY10601620	EY10601620	TANTL.CAP CHIP	10µF/ 16V
PF01	CF07		EY47601620	EY47601620	TANTL.CAP CHIP	47µF/ 16V
PF01	CF08		nsp	DK96104300	CERAMIC CAP.	C1608X7R1H104K
PF01	CF09		nsp	DK98105200	CERAMIC CAP.	1µF 10V F
PF01	CF10		nsp	DK96102300	CERAMIC CAP.	1000 PF +- 10% B 50V GR36
PF01	CF11		nsp	DK96102300	CERAMIC CAP.	1000 PF +- 10% B 50V GR36
PF01	CF12		nsp	DK96102300	CERAMIC CAP.	1000 PF +- 10% B 50V GR36
PF01	CF13		nsp	DK96471300	CERAMIC CAP.	470PF (GR39)
PF01	CF14		nsp	DK96471300	CERAMIC CAP.	470PF (GR39)
PF01	CF15		nsp	DK96471300	CERAMIC CAP.	470PF (GR39)
PF01	CF16		nsp	DK96471300	CERAMIC CAP.	470PF (GR39)
PF01	CF17		nsp	DK96471300	CERAMIC CAP.	470PF (GR39)
PF01	CF18		nsp	DK96471300	CERAMIC CAP.	470PF (GR39)
PF01	CF19		nsp	DK96471300	CERAMIC CAP.	470PF (GR39)
PF01	CF20		nsp	DK96471300	CERAMIC CAP.	470PF (GR39)
PF01	CF21		nsp	DK96471300	CERAMIC CAP.	470PF (GR39)
PF01	CF22		nsp	DK96471300	CERAMIC CAP.	470PF (GR39)
PF01	DF03		HI10003980	HI10003980	L.E.D.	NSCW215
PF01	DF04		HI10003980	HI10003980	L.E.D.	NSCW215
PF01	DF05		HI10003980	HI10003980	L.E.D.	NSCW215
PF01	DF06		HI10003980	HI10003980	L.E.D.	NSCW215
PF01	LF01		nsp	NN05000610	CHIP RESISTOR	0 OHM +- 5% 1/16W
PF01	QF01		HC12243090	HC12243090	IC	NJU6469LFG1
PF01	QF02		BA21105000	BA21105000	SEMICON.COMP	DTC123JE,RN1105
PF01	QF03		BA21105000	BA21105000	SEMICON.COMP	DTC123JE,RN1105
PF01	QF04		BA21105000	BA21105000	SEMICON.COMP	DTC123JE,RN1105
PF01	QF05		BA21105000	BA21105000	SEMICON.COMP	DTC123JE,RN1105
PF01	QF06		BA21105000	BA21105000	SEMICON.COMP	DTC123JE,RN1105
PF01	QF07		BA21105000	BA21105000	SEMICON.COMP	DTC123JE,RN1105
PF01	RF01		NY02030160	NY02030160	TRIMM.RESISTOR	EVM1S/TMC3KE/RH03AD 20K OHM
PF01	RF02		nsp	NN05153610	CHIP RESISTOR	15K OHM +- 5% 1/16W

NOTE : "nsp" PARTS IS LISTED FOR REFERENCE ONLY, MARANTZ WILL NOT SUPPLY THESE PARTS.

P.C.B. NAME	POS. NO.	VERS. COLOR	PART NO. (FOR EUR)	PART NO. (MJI)	PART NAME	DESCRIPTION
PF01	RF03		nsp	NN05101610	CHIP RESISTOR	100 OHM +- 5% 1/16W
PF01	RF04		nsp	NN05101610	CHIP RESISTOR	100 OHM +- 5% 1/16W
PF01	RF05		nsp	NN05151610	CHIP RESISTOR	150 OHM +- 5% 1/16W
PF01	RF10		nsp	NN05151610	CHIP RESISTOR	150 OHM +- 5% 1/16W
PF01	RF11		nsp	NN05101610	CHIP RESISTOR	100 OHM +- 5% 1/16W
PF01	RF12		nsp	NN05101610	CHIP RESISTOR	100 OHM +- 5% 1/16W
PF01	SF01		SP01013950	SP01013950	PUSH SWITCH	SKECAFA010
PF01	SF02		SP01013950	SP01013950	PUSH SWITCH	SKECAFA010
PF01	SF03		SP01013950	SP01013950	PUSH SWITCH	SKECAFA010
PF01	SF04		SP01013960	SP01013960	PUSH SWITCH	SKECFKA010 (RED)
PF01	SF05		SP01013970	SP01013970	PUSH SWITCH	SKECFLA010 (PURE GREEN)
PF01	SF06		SP01013950	SP01013950	PUSH SWITCH	SKECAFA010
PF01	SF07		SP01013950	SP01013950	PUSH SWITCH	SKECAFA010
PF01	SF08		SP01013950	SP01013950	PUSH SWITCH	SKECAFA010
PF01	VF01		HQ21902980	HQ21902980	DISPLAY UNIT	LCD STN 1/18DUTY 1/5BIAS
PF91	DF91		HI10042080	HI10042080	L.E.D.	SECU1E01C
PF91	RF91		nsp	NN05471610	CHIP RESISTOR	470 OHM +- 5% 1/16W
PM01	C321		nsp	DK96104300	CERAMIC CAP.	C1608X7R1H104K
PM01	C322		nsp	DK96104300	CERAMIC CAP.	C1608X7R1H104K
PM01	C340		EA47701010	EA47701010	ELECT CAP.	470µF/ 10V
PM01	C341		nsp	DD95330300	CERAMIC CAP.	33 PF +- 5% CG 50V
PM01	C342		nsp	DD95330300	CERAMIC CAP.	33 PF +- 5% CG 50V
PM01	C343		nsp	DK96104300	CERAMIC CAP.	C1608X7R1H104K
PM01	C344		nsp	DK96104300	CERAMIC CAP.	C1608X7R1H104K
PM01	C345		nsp	DD95101300	CERAMIC CAP.	100 PF +- 5% CG 50V GR39
PM01	C346		nsp	DD95101300	CERAMIC CAP.	100 PF +- 5% CG 50V GR39
PM01	C347		EY10601670	EY10601670	TANTL.CAP CHIP	MSVB21C 10µF/16V
PM01	C348		EY10601670	EY10601670	TANTL.CAP CHIP	MSVB21C 10µF/16V
PM01	C351		EY10601670	EY10601670	TANTL.CAP CHIP	MSVB21C 10µF/16V
PM01	C352		EY10601670	EY10601670	TANTL.CAP CHIP	MSVB21C 10µF/16V
PM01	C353		nsp	DD95220300	CERAMIC CAP.	22 PF +- 5% CG 50V GR39
PM01	C354		nsp	DD95220300	CERAMIC CAP.	22 PF +- 5% CG 50V GR39
PM01	C355		nsp	NN05000610	CHIP RESISTOR	0 OHM +- 5% 1/16W
PM01	C401		nsp	DK96104300	CERAMIC CAP.	C1608X7R1H104K
PM01	C402		nsp	DD95470300	CERAMIC CAP.	47 PF +- 5% CG 50V GR39
PM01	C403		nsp	DD95470300	CERAMIC CAP.	47 PF +- 5% CG 50V GR39
PM01	C404		nsp	DD95470300	CERAMIC CAP.	47 PF +- 5% CG 50V GR39
PM01	C405		nsp	DD95470300	CERAMIC CAP.	47 PF +- 5% CG 50V GR39
PM01	C406		nsp	DK96104300	CERAMIC CAP.	C1608X7R1H104K
PM01	C407		EY10601670	EY10601670	TANTL.CAP CHIP	MSVB21C 10µF/16V
PM01	C408		EY10601670	EY10601670	TANTL.CAP CHIP	MSVB21C 10µF/16V
PM01	C409		nsp	DK96104300	CERAMIC CAP.	C1608X7R1H104K
PM01	C410		nsp	DK96104300	CERAMIC CAP.	C1608X7R1H104K
PM01	C412		nsp	DK96104300	CERAMIC CAP.	C1608X7R1H104K
PM01	C413		nsp	DK98105200	CERAMIC CAP.	1µF 10V F
PM01	C414		nsp	DK96104300	CERAMIC CAP.	C1608X7R1H104K
PM01	C415		nsp	DK96104300	CERAMIC CAP.	C1608X7R1H104K
PM01	C416		nsp	DK96474200	CERAMIC CAP.	0.47µF/10V B(BJ) +-10%
PM01	C417		nsp	DK96104300	CERAMIC CAP.	C1608X7R1H104K
PM01	C418		nsp	DK96104300	CERAMIC CAP.	C1608X7R1H104K
PM01	C419		nsp	DK96104300	CERAMIC CAP.	C1608X7R1H104K
PM01	C420		EY10601070	EY10601070	TANTL.CAP CHIP	10µF/ 10V
PM01	C421		EY10601670	EY10601670	TANTL.CAP CHIP	MSVB21C 10µF/16V
PM01	C422		EY10601670	EY10601670	TANTL.CAP CHIP	MSVB21C 10µF/16V
PM01	C423		EY10601670	EY10601670	TANTL.CAP CHIP	MSVB21C 10µF/16V
PM01	C424		EY10601070	EY10601070	TANTL.CAP CHIP	10µF/ 10V
PM01	C425		EY10601670	EY10601670	TANTL.CAP CHIP	MSVB21C 10µF/16V
PM01	C426		EY10601670	EY10601670	TANTL.CAP CHIP	MSVB21C 10µF/16V
PM01	C427		EY10601070	EY10601070	TANTL.CAP CHIP	10µF/ 10V
PM01	C428		EY10601070	EY10601070	TANTL.CAP CHIP	10µF/ 10V
PM01	C429		EY10601070	EY10601070	TANTL.CAP CHIP	10µF/ 10V
PM01	C430		EY10601670	EY10601670	TANTL.CAP CHIP	MSVB21C 10µF/16V
PM01	C431		EY10601670	EY10601670	TANTL.CAP CHIP	MSVB21C 10µF/16V
PM01	C801		EA47702510	EA47702510	ELECT CAP.	470µF/ 25V
PM01	C802		EY47601620	EY47601620	TANTL.CAP CHIP	47µF/ 16V
PM01	C803		EY47701020	EY47701020	TANTL.CAP CHIP	470µF/ 10V
PM01	C804		EY10701020	EY10701020	TANTL.CAP CHIP	100µF/ 10V
PM01	C805		nsp	DK96104300	CERAMIC CAP.	C1608X7R1H104K
PM01	C806		EY10701620	EY10701620	TANTL.CAP CHIP	100µF/ 16V
PM01	C807		EY10601620	EY10601620	TANTL.CAP CHIP	10µF/ 16V

NOTE : "nsp" PARTS IS LISTED FOR REFERENCE ONLY, MARANTZ WILL NOT SUPPLY THESE PARTS.

P.C.B. NAME	POS. NO.	VERS. COLOR	PART NO. (FOR EUR)	PART NO. (MJI)	PART NAME	DESCRIPTION
PM01	C808		EY10601620	EY10601620	TANTL.CAP CHIP	10µF/ 16V
PM01	C809		EY10601620	EY10601620	TANTL.CAP CHIP	10µF/ 16V
PM01	C810		EY10701020	EY10701020	TANTL.CAP CHIP	100µF/ 10V
PM01	C811		EY33602520	EY33602520	TANTL.CAP CHIP	33µF/ 25V
PM01	C812		EY10701620	EY10701620	TANTL.CAP CHIP	100µF/ 16V
PM01	C813		EY47502520	EY47502520	TANTL.CAP CHIP	4.7µF/ 25V
PM01	C814		EY10601620	EY10601620	TANTL.CAP CHIP	10µF/ 16V
PM01	C815		EY47600620	EY47600620	TANTL.CAP CHIP	47µF/6.3V
PM01	C816		nsp	DK96104300	CERAMIC CAP.	C1608X7R1H104K
PM01	C817		nsp	DK96104300	CERAMIC CAP.	C1608X7R1H104K
PM01	C818		nsp	DK96104300	CERAMIC CAP.	C1608X7R1H104K
PM01	C819		nsp	DD95101300	CERAMIC CAP.	100 PF +- 5% CG 50V GR39
PM01	C820		nsp	DK96104300	CERAMIC CAP.	C1608X7R1H104K
PM01	C821		nsp	DK96222300	CERAMIC CAP.	2200PF (GR39)
PM01	C822		nsp	DK96103300	CERAMIC CAP.	0.01µF +-10% 50V C1608JB1H103K
PM01	C825		nsp	DK96103300	CERAMIC CAP.	0.01µF +-10% 50V C1608JB1H103K
PM01	C826		nsp	DK96222300	CERAMIC CAP.	2200PF (GR39)
PM01	C827		nsp	DK96104300	CERAMIC CAP.	C1608X7R1H104K
PM01	C828		nsp	DK96104300	CERAMIC CAP.	C1608X7R1H104K
PM01	C829		nsp	DK96104300	CERAMIC CAP.	C1608X7R1H104K
PM01	C831		nsp	DK96104300	CERAMIC CAP.	C1608X7R1H104K
PM01	C832		nsp	DK96104300	CERAMIC CAP.	C1608X7R1H104K
PM01	C833		nsp	DK96104300	CERAMIC CAP.	C1608X7R1H104K
PM01	C834		nsp	DK96104300	CERAMIC CAP.	C1608X7R1H104K
PM01	C835		nsp	DD91100300	CERAMIC CAP.	10 PF +- 0.5 PF CH 50V GR39
PM01	C836		nsp	DD91100300	CERAMIC CAP.	10 PF +- 0.5 PF CH 50V GR39
PM01	C837		nsp	DK96104300	CERAMIC CAP.	C1608X7R1H104K
PM01	C838		nsp	DK96104300	CERAMIC CAP.	C1608X7R1H104K
PM01	C839		nsp	DK96103300	CERAMIC CAP.	0.01µF +-10% 50V C1608JB1H103K
PM01	C842		nsp	DD95101300	CERAMIC CAP.	100 PF +- 5% CG 50V GR39
PM01	C844		nsp	DK96104300	CERAMIC CAP.	C1608X7R1H104K
PM01	C845		nsp	DK96103300	CERAMIC CAP.	0.01µF +-10% 50V C1608JB1H103K
PM01	C848		nsp	DK96104300	CERAMIC CAP.	C1608X7R1H104K
PM01	C849		nsp	DK96221300	CERAMIC CAP.	220PF (GR39)
PM01	C850		nsp	DD95101300	CERAMIC CAP.	100 PF +- 5% CG 50V GR39
PM01	C853		nsp	DD91100300	CERAMIC CAP.	10 PF +- 0.5 PF CH 50V GR39
PM01	C854		nsp	DK96103300	CERAMIC CAP.	0.01µF +-10% 50V C1608JB1H103K
PM01	C855		EY47600620	EY47600620	TANTL.CAP CHIP	47µF/6.3V
PM01	C856		EY47600620	EY47600620	TANTL.CAP CHIP	47µF/6.3V
PM01	C857		nsp	DK96104300	CERAMIC CAP.	C1608X7R1H104K
PM01	C858		nsp	DK96104300	CERAMIC CAP.	C1608X7R1H104K
PM01	C859		nsp	DK96104300	CERAMIC CAP.	C1608X7R1H104K
PM01	C861		EY10701620	EY10701620	TANTL.CAP CHIP	100µF/ 16V
PM01	C862		EY10701620	EY10701620	TANTL.CAP CHIP	100µF/ 16V
PM01	C863		EY22601620	EY22601620	TANTL.CAP CHIP	22µF/ 16V
PM01	CB01		nsp	DD95101300	CERAMIC CAP.	100 PF +- 5% CG 50V GR39
PM01	CB02		nsp	DK96104300	CERAMIC CAP.	C1608X7R1H104K
PM01	CB03		nsp	DD95101300	CERAMIC CAP.	100 PF +- 5% CG 50V GR39
PM01	CB04		nsp	DK96104300	CERAMIC CAP.	C1608X7R1H104K
PM01	CB05		EY10601670	EY10601670	TANTL.CAP CHIP	MSVB21C 10µF/16V
PM01	CB06		nsp	DK96104300	CERAMIC CAP.	C1608X7R1H104K
PM01	CB07		nsp	DK96104300	CERAMIC CAP.	C1608X7R1H104K
PM01	CB24		EY10601670	EY10601670	TANTL.CAP CHIP	MSVB21C 10µF/16V
PM01	CB25		EY10601670	EY10601670	TANTL.CAP CHIP	MSVB21C 10µF/16V
PM01	CB28		nsp	DK96104300	CERAMIC CAP.	C1608X7R1H104K
PM01	CB29		nsp	DK96104300	CERAMIC CAP.	C1608X7R1H104K
PM01	CB31		nsp	DK96104300	CERAMIC CAP.	C1608X7R1H104K
PM01	CB32		nsp	DK96104300	CERAMIC CAP.	C1608X7R1H104K
PM01	CB34		EY10601670	EY10601670	TANTL.CAP CHIP	MSVB21C 10µF/16V
PM01	CB35		EY10601670	EY10601670	TANTL.CAP CHIP	MSVB21C 10µF/16V
PM01	CB36		EY10601670	EY10601670	TANTL.CAP CHIP	10µF/ 10V
PM01	CB37		EY10601670	EY10601670	TANTL.CAP CHIP	10µF/ 10V
PM01	CB39		EY10701620	EY10701620	TANTL.CAP CHIP	100µF/ 16V
PM01	CB40		EY10701620	EY10701620	TANTL.CAP CHIP	100µF/ 16V
PM01	CB41		EY10601670	EY10601670	TANTL.CAP CHIP	MSVB21C 10µF/16V
PM01	CB42		EY10601670	EY10601670	TANTL.CAP CHIP	MSVB21C 10µF/16V
PM01	CB51		nsp	DD95470300	CERAMIC CAP.	47 PF +- 5% CG 50V GR39
PM01	CB52		nsp	DD95470300	CERAMIC CAP.	47 PF +- 5% CG 50V GR39
PM01	CD01		nsp	DK96104300	CERAMIC CAP.	C1608X7R1H104K
PM01	CD02		nsp	DK96104300	CERAMIC CAP.	C1608X7R1H104K

NOTE : "nsp" PARTS IS LISTED FOR REFERENCE ONLY, MARANTZ WILL NOT SUPPLY THESE PARTS.

P.C.B. NAME	POS. NO.	VERS. COLOR	PART NO. (FOR EUR)	PART NO. (MJI)	PART NAME	DESCRIPTION
PM01	CD03		nsp	DK96104300	CERAMIC CAP.	C1608X7R1H104K
PM01	CD04		nsp	DK96104300	CERAMIC CAP.	C1608X7R1H104K
PM01	CD05		nsp	DK96104300	CERAMIC CAP.	C1608X7R1H104K
PM01	CD06		nsp	DK96104300	CERAMIC CAP.	C1608X7R1H104K
PM01	CD07		nsp	DK96104300	CERAMIC CAP.	C1608X7R1H104K
PM01	CD08		nsp	DK96104300	CERAMIC CAP.	C1608X7R1H104K
PM01	CD09		nsp	DK96104300	CERAMIC CAP.	C1608X7R1H104K
PM01	CD10		nsp	DK98105200	CERAMIC CAP.	1µF 10V F
PM01	CD11		nsp	DK98105200	CERAMIC CAP.	1µF 10V F
PM01	CD12		nsp	DK96104300	CERAMIC CAP.	C1608X7R1H104K
PM01	CD13		nsp	DK96104300	CERAMIC CAP.	C1608X7R1H104K
PM01	CD14		nsp	DK96104300	CERAMIC CAP.	C1608X7R1H104K
PM01	CD15		nsp	DK96104300	CERAMIC CAP.	C1608X7R1H104K
PM01	CD16		nsp	DK96104300	CERAMIC CAP.	C1608X7R1H104K
PM01	CD17		nsp	DK96104300	CERAMIC CAP.	C1608X7R1H104K
PM01	CD18		nsp	DK96104300	CERAMIC CAP.	C1608X7R1H104K
PM01	CD19		nsp	DK96104300	CERAMIC CAP.	C1608X7R1H104K
PM01	CD20		nsp	DK96104300	CERAMIC CAP.	C1608X7R1H104K
PM01	CL03		nsp	DD95470300	CERAMIC CAP.	47 PF +- 5% CG 50V GR39
PM01	CL04		nsp	DD95470300	CERAMIC CAP.	47 PF +- 5% CG 50V GR39
PM01	CL05		nsp	DK96104300	CERAMIC CAP.	C1608X7R1H104K
PM01	CL06		nsp	DK96104300	CERAMIC CAP.	C1608X7R1H104K
PM01	CL07		nsp	DK96104300	CERAMIC CAP.	C1608X7R1H104K
PM01	CL09		EY10601670	EY10601670	TANTL.CAP CHIP	MSVB21C 10µF/16V
PM01	CL10		EY10601670	EY10601670	TANTL.CAP CHIP	MSVB21C 10µF/16V
PM01	CL11		EY10701620	EY10701620	TANTL.CAP CHIP	100µF/ 16V
PM01	CL12		EY10701620	EY10701620	TANTL.CAP CHIP	100µF/ 16V
PM01	CL21		nsp	DD95221300	CERAMIC CAP.	220 PF +- 5% CG 50V GR39
PM01	CL22		nsp	DD95221300	CERAMIC CAP.	220 PF +- 5% CG 50V GR39
PM01	CL23		nsp	DD95221300	CERAMIC CAP.	220 PF +- 5% CG 50V GR39
PM01	CL37		EY10601670	EY10601670	TANTL.CAP CHIP	MSVB21C 10µF/16V
PM01	CL38		EY10601670	EY10601670	TANTL.CAP CHIP	MSVB21C 10µF/16V
PM01	CL41		EY10601670	EY10601670	TANTL.CAP CHIP	MSVB21C 10µF/16V
PM01	CL42		EY10601670	EY10601670	TANTL.CAP CHIP	MSVB21C 10µF/16V
PM01	CP01		nsp	DD95220300	CERAMIC CAP.	22 PF +- 5% CG 50V GR39
PM01	CP02		nsp	DD95220300	CERAMIC CAP.	22 PF +- 5% CG 50V GR39
PM01	CP03		nsp	DD95220300	CERAMIC CAP.	22 PF +- 5% CG 50V GR39
PM01	CP04		nsp	DD95220300	CERAMIC CAP.	22 PF +- 5% CG 50V GR39
PM01	CP05		nsp	DK96104300	CERAMIC CAP.	C1608X7R1H104K
PM01	CP06		nsp	DK96104300	CERAMIC CAP.	C1608X7R1H104K
PM01	CP07		nsp	DK96104300	CERAMIC CAP.	C1608X7R1H104K
PM01	CP08		nsp	DK96104300	CERAMIC CAP.	C1608X7R1H104K
PM01	CU03		nsp	DD91100300	CERAMIC CAP.	10 PF +- 0.5 PF CH 50V GR39
PM01	CU04		nsp	DD91100300	CERAMIC CAP.	10 PF +- 0.5 PF CH 50V GR39
PM01	CU05		nsp	DK96104300	CERAMIC CAP.	C1608X7R1H104K
PM01	CU07		nsp	DK96104300	CERAMIC CAP.	10K OHM +- 5% 1/16W
PM01	CU08		EY10601070	EY10601070	TANTL.CAP CHIP	10µF/ 10V
PM01	CU12		nsp	DK96104300	CERAMIC CAP.	10K OHM +- 5% 1/16W
PM01	CU13		EY10601070	EY10601070	TANTL.CAP CHIP	10µF/ 10V
PM01	CU14		nsp	DD90040300	CERAMIC CAP.	4 PF +- 0.25 PF CH 50V GR39
PM01	CU15		nsp	DD90040300	CERAMIC CAP.	4 PF +- 0.25 PF CH 50V GR39
PM01	CU16		nsp	DK98105200	CERAMIC CAP.	1µF 10V F
PM01	CU17		nsp	DD95101300	CERAMIC CAP.	100 PF +- 5% CG 50V GR39
PM01	CU18		nsp	DK96471300	CERAMIC CAP.	470PF (GR39)
PM01	CU19		nsp	DK96471300	CERAMIC CAP.	470PF (GR39)
PM01	CU20		nsp	DK96471300	CERAMIC CAP.	470PF (GR39)
PM01	CU21		nsp	DK96471300	CERAMIC CAP.	470PF (GR39)
PM01	CU22		nsp	DK96471300	CERAMIC CAP.	470PF (GR39)
PM01	CU23		nsp	DK96471300	CERAMIC CAP.	470PF (GR39)
PM01	CU24		nsp	DK96471300	CERAMIC CAP.	470PF (GR39)
PM01	CU25		nsp	DK96471300	CERAMIC CAP.	470PF (GR39)
PM01	CU26		nsp	DK98105200	CERAMIC CAP.	1µF 10V F
PM01	CU27		nsp	DK96104300	CERAMIC CAP.	C1608X7R1H104K
PM01	CU31		nsp	DK96104300	CERAMIC CAP.	C1608X7R1H104K
PM01	CU32		nsp	DK96104300	CERAMIC CAP.	C1608X7R1H104K
PM01	CU37		nsp	DK96104300	CERAMIC CAP.	C1608X7R1H104K
PM01	CU61		nsp	DK96104300	CERAMIC CAP.	C1608X7R1H104K
PM01	CU62		nsp	DK96104300	CERAMIC CAP.	C1608X7R1H104K
PM01	CU63		nsp	DK96104300	CERAMIC CAP.	C1608X7R1H104K
PM01	CU64		nsp	DK96104300	CERAMIC CAP.	C1608X7R1H104K

NOTE : "nsp" PARTS IS LISTED FOR REFERENCE ONLY, MARANTZ WILL NOT SUPPLY THESE PARTS.

P.C.B. NAME	POS. NO.	VERS. COLOR	PART NO. (FOR EUR)	PART NO. (MJI)	PART NAME	DESCRIPTION
PM01	CU65		EY10601620	EY10601620	TANTL.CAP CHIP	10µF/ 16V
PM01	CU91		nsp	DK96104300	CERAMIC CAP.	C1608X7R1H104K
PM01	CX02		nsp	DK96104300	CERAMIC CAP.	C1608X7R1H104K
PM01	CX03		nsp	DK96104300	CERAMIC CAP.	C1608X7R1H104K
PM01	CX04		nsp	DK96104300	CERAMIC CAP.	C1608X7R1H104K
PM01	CX05		nsp	DK96103300	CERAMIC CAP.	0.01µF +-10% 50V C1608JB1H103K
PM01	CX07		nsp	DK96104300	CERAMIC CAP.	C1608X7R1H104K
PM01	CX10		nsp	DK96104300	CERAMIC CAP.	C1608X7R1H104K
PM01	CX13		nsp	DK96104300	CERAMIC CAP.	C1608X7R1H104K
PM01	CX14		nsp	DK96104300	CERAMIC CAP.	C1608X7R1H104K
PM01	CX15		EY10601070	EY10601070	TANTL.CAP CHIP	10µF/ 10V
PM01	CX16		nsp	DK96104300	CERAMIC CAP.	C1608X7R1H104K
PM01	CX17		nsp	DK96104300	CERAMIC CAP.	C1608X7R1H104K
PM01	CX18		nsp	DK96104300	CERAMIC CAP.	C1608X7R1H104K
PM01	CX19		nsp	DK96104300	CERAMIC CAP.	C1608X7R1H104K
PM01	CX20		nsp	DK96104300	CERAMIC CAP.	C1608X7R1H104K
PM01	CX21		nsp	DK96104300	CERAMIC CAP.	C1608X7R1H104K
PM01	CX22		EY10601070	EY10601070	TANTL.CAP CHIP	10µF/ 10V
PM01	CX25		nsp	DK96104300	CERAMIC CAP.	C1608X7R1H104K
PM01	CX26		nsp	DK96104300	CERAMIC CAP.	C1608X7R1H104K
PM01	CX27		nsp	DK96474200	CERAMIC CAP.	0.47µF/10V B(BJ) +-10%
PM01	CX51		nsp	DK96224200	CERAMIC CAP.	0.22µF +- 10% B 10V
PM01	CX52		nsp	DK96104300	CERAMIC CAP.	C1608X7R1H104K
PM01	CX53		nsp	DK96105200	CERAMIC CAP.	1µF B 6.3V
PM01	D302		HZ21005000	HZ21005000	CHIP DIODE	1SS301,DAN202U UMT TYPE
PM01	D381		HZ30015050	HZ30015050	CHIP DIODE	02CZ6.8Z ZENER DIODE
PM01	D382		HZ20045020	HZ20045020	CHIP DIODE	MA1S121 DIODE
PM01	D383		HZ20045020	HZ20045020	CHIP DIODE	MA1S121 DIODE
PM01	D801		HZ21005000	HZ21005000	CHIP DIODE	1SS301,DAN202U UMT TYPE
PM01	D802		HZ21005000	HZ21005000	CHIP DIODE	1SS301,DAN202U UMT TYPE
PM01	D803		HZ21005000	HZ21005000	CHIP DIODE	1SS301,DAN202U UMT TYPE
PM01	D804		HZ21005000	HZ21005000	CHIP DIODE	1SS301,DAN202U UMT TYPE
PM01	D805		HZ21005000	HZ21005000	CHIP DIODE	1SS301,DAN202U UMT TYPE
PM01	D806		HZ20061210	HZ20061210	CHIP DIODE	RB160L-40 TE25 SBD 40V 1A PMDS
PM01	D807		HZ20061210	HZ20061210	CHIP DIODE	RB160L-40 TE25 SBD 40V 1A PMDS
PM01	D808		HZ20061210	HZ20061210	CHIP DIODE	RB160L-40 TE25 SBD 40V 1A PMDS
PM01	D810		HZ20061210	HZ20061210	CHIP DIODE	RB160L-40 TE25 SBD 40V 1A PMDS
PM01	D813		HZ20061210	HZ20061210	CHIP DIODE	RB160L-40 TE25 SBD 40V 1A PMDS
PM01	D814		HZ30021050	HZ30021050	CHIP DIODE	02CZ15Y
PM01	D815		HZ30015050	HZ30015050	CHIP DIODE	02CZ6.8Z ZENER DIODE
PM01	D816		HZ30010050	HZ30010050	CHIP DIODE	02CZ20Z
PM01	D817		HZ20061210	HZ20061210	CHIP DIODE	RB160L-40 TE25 SBD 40V 1A PMDS
PM01	D820		HZ21006000	HZ21006000	CHIP DIODE	1SS300,DAP202U UMT TYPE
PM01	D861		HZ21005000	HZ21005000	CHIP DIODE	1SS301,DAN202U UMT TYPE
PM01	D862		HZ30017050	HZ30017050	CHIP DIODE	DIODE 02CZ4.7Z
PM01	DB01		HZ30004050	HZ30004050	CHIP DIODE	02SZ8.2-Y TE85L
PM01	DB02		HZ30004050	HZ30004050	CHIP DIODE	02SZ8.2-Y TE85L
PM01	DL01		HZ30017050	HZ30017050	CHIP DIODE	DIODE 02CZ4.7Z
PM01	DL02		HZ30017050	HZ30017050	CHIP DIODE	DIODE 02CZ4.7Z
PM01	DL03		HZ30017050	HZ30017050	CHIP DIODE	DIODE 02CZ4.7Z
PM01	DL04		HZ30017050	HZ30017050	CHIP DIODE	DIODE 02CZ4.7Z
PM01	DU01		HZ21005000	HZ21005000	CHIP DIODE	1SS301,DAN202U UMT TYPE
PM01	DU02		HZ30023050	HZ30023050	CHIP DIODE	02CZ2.4X TOSHIBA
PM01	DU03		HZ21005000	HZ21005000	CHIP DIODE	1SS301,DAN202U UMT TYPE
PM01	DU04		HZ21005000	HZ21005000	CHIP DIODE	1SS301,DAN202U UMT TYPE
PM01	DU11		HZ21005000	HZ21005000	CHIP DIODE	1SS301,DAN202U UMT TYPE
PM01	DU12		HZ21005000	HZ21005000	CHIP DIODE	1SS301,DAN202U UMT TYPE
PM01	DU13		HZ21005000	HZ21005000	CHIP DIODE	1SS301,DAN202U UMT TYPE
PM01	DX01		HZ21005000	HZ21005000	CHIP DIODE	1SS301,DAN202U UMT TYPE
PM01	DX61		HZ21005000	HZ21005000	CHIP DIODE	1SS301,DAN202U UMT TYPE
PM01	JU11		YJ14000080	YJ14000080	BATTERY CASE	20H-1T (CR2032 HOLDER) SANYO
PM01	JX01		YJ90014570	YJ90014570	JACK	55358-5021 C/F CARD HEADER
PM01	JX03		ZK04AS0010	ZK04AS0010	UNIT KIT	55364-0011 C/F CARD EJECTOR
PM01	L301		FN31010030	FN31010030	EMI FILTER	BLM11B102S 1608 EMIFILTER
PM01	L302		FN31010030	FN31010030	EMI FILTER	BLM11B102S 1608 EMIFILTER
PM01	L404		FC90020110	FC90020110	FERRITE CORE	BLM11B601S CHIP FERRITE
PM01	L801		LU12103010	LU12103010	CHIP	NL322522-100K
PM01	L803		LU83103030	LU83103030	CHIP	CDRH5D28 10µH +- 30%
PM01	L804		LU80104030	LU80104030	CHIP	CDRH5D28-101
PM01	L805		LU12103010	LU12103010	CHIP	NL322522-100K

NOTE : "nsp" PARTS IS LISTED FOR REFERENCE ONLY, MARANTZ WILL NOT SUPPLY THESE PARTS.

P.C.B. NAME	POS. NO.	VERS. COLOR	PART NO. (FOR EUR)	PART NO. (MJI)	PART NAME	DESCRIPTION
PM01	L806		LU12103010	LU12103010	CHIP	NL322522-100K
PM01	L807		LU83683030	LU83683030	CHIP	CDRH5D28 680 68μH +- 30% 520MA
PM01	L808		LU12103010	LU12103010	CHIP	NL322522-100K
PM01	L809		LU83683030	LU83683030	CHIP	CDRH5D28 680 68μH +- 30% 520MA
PM01	L810		LU12103010	LU12103010	CHIP	NL322522-100K
PM01	L811		LU80473060	LU80473060	CHIP	D63LCB A921CY-470M
PM01	L812		LU80104020	LU80104020	CHIP	CDRH8D43-101NC
PM01	L813		LU80473060	LU80473060	CHIP	D63LCB A921CY-470M
PM01	LD01		FC90020110	FC90020110	FERRITE CORE	BLM11B601S CHIP FERRITE
PM01	LD02		FC90020110	FC90020110	FERRITE CORE	BLM11B601S CHIP FERRITE
PM01	LU02		FN31010030	FN31010030	EMI FILTER	BLM11B102S 1608 EMIFILTER
PM01	LU04		FN31010030	FN31010030	EMI FILTER	BLM11B102S 1608 EMIFILTER
PM01	LU05		FN31010030	FN31010030	EMI FILTER	BLM11B102S 1608 EMIFILTER
PM01	LU06		FN31010030	FN31010030	EMI FILTER	BLM11B102S 1608 EMIFILTER
PM01	LU07		FN31010030	FN31010030	EMI FILTER	BLM11B102S 1608 EMIFILTER
PM01	LU08		FN31010030	FN31010030	EMI FILTER	BLM11B102S 1608 EMIFILTER
PM01	LU09		FN31010030	FN31010030	EMI FILTER	BLM11B102S 1608 EMIFILTER
PM01	LU10		FN31010030	FN31010030	EMI FILTER	BLM11B102S 1608 EMIFILTER
PM01	LU11		FN31010030	FN31010030	EMI FILTER	BLM11B102S 1608 EMIFILTER
PM01	LU12		FN31010030	FN31010030	EMI FILTER	BLM11B102S 1608 EMIFILTER
PM01	LU23		FN31010030	FN31010030	EMI FILTER	BLM11B102S 1608 EMIFILTER
PM01	LU24		FN31010030	FN31010030	EMI FILTER	BLM11B102S 1608 EMIFILTER
PM01	LU25		FN31010030	FN31010030	EMI FILTER	BLM11B102S 1608 EMIFILTER
PM01	LU26		FN31010030	FN31010030	EMI FILTER	BLM11B102S 1608 EMIFILTER
PM01	LU27		nsp	NN05102610	CHIP RESISTOR	1K OHM +- 5% 1/16W
PM01	LU28		nsp	NN05102610	CHIP RESISTOR	1K OHM +- 5% 1/16W
PM01	LU29		nsp	NN05102610	CHIP RESISTOR	1K OHM +- 5% 1/16W
PM01	LU30		nsp	NN05102610	CHIP RESISTOR	1K OHM +- 5% 1/16W
PM01	LU33		nsp	NN05102610	CHIP RESISTOR	1K OHM +- 5% 1/16W
PM01	LU34		nsp	NN05102610	CHIP RESISTOR	1K OHM +- 5% 1/16W
PM01	LU36		nsp	NN05102610	CHIP RESISTOR	1K OHM +- 5% 1/16W
PM01	LU37		nsp	NN05102610	CHIP RESISTOR	1K OHM +- 5% 1/16W
PM01	LU38		nsp	NN05102610	CHIP RESISTOR	1K OHM +- 5% 1/16W
PM01	LU39		nsp	NN05102610	CHIP RESISTOR	1K OHM +- 5% 1/16W
PM01	LU40		nsp	NN05102610	CHIP RESISTOR	1K OHM +- 5% 1/16W
PM01	LU41		nsp	NN05102610	CHIP RESISTOR	1K OHM +- 5% 1/16W
PM01	LU42		nsp	NN05102610	CHIP RESISTOR	1K OHM +- 5% 1/16W
PM01	LU43		nsp	NN05102610	CHIP RESISTOR	1K OHM +- 5% 1/16W
PM01	LX02		FN31010030	FN31010030	EMI FILTER	BLM11B102S 1608 EMIFILTER
PM01	Q301		HC10168090	HC10168090	IC	NJM2068V (OP-AMP)
PM01	Q302		HC10168090	HC10168090	IC	NJM2068V (OP-AMP)
PM01	Q314		BA20080210	BA20080210	SEMICON.COMP	DTC323TU
PM01	Q321		BA20080210	BA20080210	SEMICON.COMP	DTC323TU
PM01	Q322		BA20080210	BA20080210	SEMICON.COMP	DTC323TU
PM01	Q323		BA20080210	BA20080210	SEMICON.COMP	DTC323TU
PM01	Q327		BA10026210	BA10026210	SEMICON.COMP	DTA114EU
PM01	Q328		BA20035210	BA20035210	SEMICON.COMP	DTC114EU
PM01	Q330		BA10026210	BA10026210	SEMICON.COMP	DTA114EU
PM01	Q332		BA20035210	BA20035210	SEMICON.COMP	DTC114EU
PM01	Q381		BA20035210	BA20035210	SEMICON.COMP	DTC114EU
PM01	Q401		HC10037480	HC10037480	IC	AK4114 DIT
PM01	Q402		HC10035480	HC10035480	IC	ADC AK5380VT 24BIT DR=105DB
PM01	Q403		HC10036480	HC10036480	IC	AK4380VT-E2 DAC
PM01	Q405		HC10168090	HC10168090	IC	NJM2068V (OP-AMP)
PM01	Q801		HX117971A0	HX117971A0	CHIP TR.	2SA1797
PM01	Q802		HX115762A0	HX115762A0	CHIP TR.	2SA1576(FQ,FR)
PM01	Q803		HC10036090	HC10036090	IC	NJM2904M
PM01	Q804		HY10360000	HY10360000	CHIP FET	2SJ360
PM01	Q805		HC10036090	HC10036090	IC	NJM2904M
PM01	Q806		HX117971A0	HX117971A0	CHIP TR.	2SA1797
PM01	Q807		HX117971A0	HX117971A0	CHIP TR.	2SA1797
PM01	Q808		HC011017K0	HC011017K0	IC	MC74VHC14DT
PM01	Q809		HC011017K0	HC011017K0	IC	MC74VHC14DT
PM01	Q810		HX117971A0	HX117971A0	CHIP TR.	2SA1797
PM01	Q811		HX117971A0	HX117971A0	CHIP TR.	2SA1797
PM01	Q812		HX117971A0	HX117971A0	CHIP TR.	2SA1797
PM01	Q813		HX117971A0	HX117971A0	CHIP TR.	2SA1797
PM01	Q814		BA20021210	BA20021210	SEMICON.COMP	DTC144EC (ROHM)
PM01	Q816		HC10106530	HC10106530	IC	S-8521D33MC-BXS
PM01	Q817		BA10026210	BA10026210	SEMICON.COMP	DTA114EU

NOTE : "nsp" PARTS IS LISTED FOR REFERENCE ONLY, MARANTZ WILL NOT SUPPLY THESE PARTS.



P.C.B. NAME	POS. NO.	VERS. COLOR	PART NO. (FOR EUR)	PART NO. (MJI)	PART NAME	DESCRIPTION
PM01	Q819		HC10226210	HC10226210	IC	BA9741FS-E2 2CH DC-DC
PM01	Q820		HC12241090	HC12241090	IC	NJM2373AF
PM01	Q822		HC90005090	HC90005090	IC	NJM78L05UA CHIP REG (JRC)
PM01	Q823		BA10026210	BA10026210	SEMICON.COMP	DTA114EU
PM01	Q824		HX300012A0	HX300012A0	CHIP TR.	2SC4081 (Q,R) 2SC4116 (Y,GR)
PM01	Q825		BA20035210	BA20035210	SEMICON.COMP	DTC114EU
PM01	Q829		HX300012A0	HX300012A0	CHIP TR.	2SC4081 (Q,R) 2SC4116 (Y,GR)
PM01	Q831		HX346721A0	HX346721A0	CHIP TR.	2SC4672 Q
PM01	Q832		HX300012A0	HX300012A0	CHIP TR.	2SC4081 (Q,R) 2SC4116 (Y,GR)
PM01	Q833		HX300012A0	HX300012A0	CHIP TR.	2SC4081 (Q,R) 2SC4116 (Y,GR)
PM01	Q836		HX300012A0	HX300012A0	CHIP TR.	2SC4081 (Q,R) 2SC4116 (Y,GR)
PM01	Q838		HX300012A0	HX300012A0	CHIP TR.	2SC4081 (Q,R) 2SC4116 (Y,GR)
PM01	Q839		HX300012A0	HX300012A0	CHIP TR.	2SC4081 (Q,R) 2SC4116 (Y,GR)
PM01	Q840		HX300012A0	HX300012A0	CHIP TR.	2SC4081 (Q,R) 2SC4116 (Y,GR)
PM01	Q841		HX300012A0	HX300012A0	CHIP TR.	2SC4081 (Q,R) 2SC4116 (Y,GR)
PM01	Q843		HX346721A0	HX346721A0	CHIP TR.	2SC4672 Q
PM01	Q844		HX300012A0	HX300012A0	CHIP TR.	2SC4081 (Q,R) 2SC4116 (Y,GR)
PM01	Q845		HX300012A0	HX300012A0	CHIP TR.	2SC4081 (Q,R) 2SC4116 (Y,GR)
PM01	Q846		HX300012A0	HX300012A0	CHIP TR.	2SC4081 (Q,R) 2SC4116 (Y,GR)
PM01	Q847		HX346721A0	HX346721A0	CHIP TR.	2SC4672 Q
PM01	Q848		HX300012A0	HX300012A0	CHIP TR.	2SC4081 (Q,R) 2SC4116 (Y,GR)
PM01	Q849		BA20035210	BA20035210	SEMICON.COMP	DTC114EU
PM01	Q852		HX117971A0	HX117971A0	CHIP TR.	2SA1797
PM01	QB05		HC10168090	HC10168090	IC	NJM2068V (OP-AMP)
PM01	QB06		HC405321Y0	HC405321Y0	DIGITAL C-MOS	BU4053BCFV
PM01	QB07		HC10168090	HC10168090	IC	NJM2068V (OP-AMP)
PM01	QB08		HC405221I0	HC405221I0	DIGITAL C-MOS	BU4052BCF
PM01	QB10		BA20035210	BA20035210	SEMICON.COMP	DTC114EU
PM01	QB11		BA20035210	BA20035210	SEMICON.COMP	DTC114EU
PM01	QB12		BA20035210	BA20035210	SEMICON.COMP	DTC114EU
PM01	QD01		HC10133370	HC10133370	IC	TMS320VC5416PGE-160
PM01	QD02		HS04ASX000	HS04ASX000	ONE TIME PROM	M29W800DB70N6
PM01	QD03		HC10015590	HC10015590	IC	M68AW256M70ND1 4M 3V SRAM
PM01	QD04		HC10015590	HC10015590	IC	M68AW256M70ND1 4M 3V SRAM
PM01	QL01		HC10168090	HC10168090	IC	NJM2068V (OP-AMP)
PM01	QL02		HC10432050	HC10432050	IC	TC9413P ELECTRIC VOLUME
PM01	QL03		HC700801P0	HC700801P0	IC	HD74LVC08
PM01	QP01		HC10232990	HC10232990	IC	XC9536XL-VQ64-10C W/PROGRAM
PM01	QP02		HC700400Z0	HC700400Z0	IC	CMOS 74HCU04 FLAT TAPING
PM01	QP03		BA20035210	BA20035210	SEMICON.COMP	DTC114EU
PM01	QP04		BA20035210	BA20035210	SEMICON.COMP	DTC114EU
PM01	QU01		HS49ASH10F	HS49ASH10F	ONE TIME PROM	H8S/2328 HD64F2328 VTE PMD570
PM01	QU02		HC10227210	HC10227210	IC	BD4719G-TR RESET IC 1.9V
PM01	QU03		HC10431990	HC10431990	IC	AT24C04N-10SI-2.5(SHRINK)
PM01	QU04		HC10036770	HC10036770	IC	RS5C372A-E2
PM01	QU06		HX300012A0	HX300012A0	CHIP TR.	2SC4081 (Q,R) 2SC4116 (Y,GR)
PM01	QU10		BA20035210	BA20035210	SEMICON.COMP	DTC114EU
PM01	QU11		BA20021210	BA20021210	SEMICON.COMP	DTC144EC (ROHM)
PM01	QU12		HX115762A0	HX115762A0	CHIP TR.	2SA1576(FQ,FR)
PM01	QU13		HX300012A0	HX300012A0	CHIP TR.	2SC4081 (Q,R) 2SC4116 (Y,GR)
PM01	QU14		HX300012A0	HX300012A0	CHIP TR.	2SC4081 (Q,R) 2SC4116 (Y,GR)
PM01	QU15		HC98905320	HC98905320	IC	PQ05DZ11U
PM01	QU16		HC91A33770	HC91A33770	IC	RN5RZ33BA-TR
PM01	QU21		HX115762A0	HX115762A0	CHIP TR.	2SA1576(FQ,FR)
PM01	QU22		BA20035210	BA20035210	SEMICON.COMP	DTC114EU
PM01	QU23		BA10026210	BA10026210	SEMICON.COMP	DTA114EU
PM01	QU24		BA20035210	BA20035210	SEMICON.COMP	DTC114EU
PM01	QU26		BA20035210	BA20035210	SEMICON.COMP	DTC114EU
PM01	QU27		BA10026210	BA10026210	SEMICON.COMP	DTA114EU
PM01	QU28		BA20035210	BA20035210	SEMICON.COMP	DTC114EU
PM01	QU29		BA20035210	BA20035210	SEMICON.COMP	DTC114EU
PM01	QU51		BA20035210	BA20035210	SEMICON.COMP	DTC114EU
PM01	QX01		HC10233990	HC10233990	IC	GL641USB C/F CONT. USB DRIVER
PM01	QX03		HC010817K0	HC010817K0	IC	MC74LVX541DT
PM01	QX04		HC010717K0	HC010717K0	IC	MC74LVX245DT
PM01	QX05		HC010717K0	HC010717K0	IC	MC74LVX245DT
PM01	QX06		HX117971A0	HX117971A0	CHIP TR.	2SA1797
PM01	QX07		BA20035210	BA20035210	SEMICON.COMP	DTC114EU
PM01	QX08		HX117971A0	HX117971A0	CHIP TR.	2SA1797
PM01	QX09		BA20035210	BA20035210	SEMICON.COMP	DTC114EU

NOTE : "nsp" PARTS IS LISTED FOR REFERENCE ONLY, MARANTZ WILL NOT SUPPLY THESE PARTS.

P.C.B. NAME	POS. NO.	VERS. COLOR	PART NO. (FOR EUR)	PART NO. (MJI)	PART NAME	DESCRIPTION
PM01	QX10		BA20035210	BA20035210	SEMICON.COMP	DTC114EU
PM01	QX11		HC009305K0	HC009305K0	IC	TC74VHC00FT
PM01	QX12		HC712300Z0	HC712300Z0	IC	CMOS LOGIC IC 74HC123 (FLAT)
PM01	R327		nsp	NN05223610	CHIP RESISTOR	22K OHM +- 5% 1/16W
PM01	R328		nsp	NN05223610	CHIP RESISTOR	22K OHM +- 5% 1/16W
PM01	R329		nsp	NN05223610	CHIP RESISTOR	22K OHM +- 5% 1/16W
PM01	R330		nsp	NN05223610	CHIP RESISTOR	22K OHM +- 5% 1/16W
PM01	R331		nsp	NN05104610	CHIP RESISTOR	100K OHM +- 5% 1/16W
PM01	R332		nsp	NN05104610	CHIP RESISTOR	100K OHM +- 5% 1/16W
PM01	R333		nsp	NN05103610	CHIP RESISTOR	10K OHM +- 5% 1/16W
PM01	R334		nsp	NN05103610	CHIP RESISTOR	10K OHM +- 5% 1/16W
PM01	R351		nsp	NN05103610	CHIP RESISTOR	10K OHM +- 5% 1/16W
PM01	R352		nsp	NN05103610	CHIP RESISTOR	10K OHM +- 5% 1/16W
PM01	R353		nsp	NN05123610	CHIP RESISTOR	12K OHM +- 5% 1/16W
PM01	R354		nsp	NN05123610	CHIP RESISTOR	12K OHM +- 5% 1/16W
PM01	R355		nsp	NN05472610	CHIP RESISTOR	4.7K OHM +- 5% 1/16W
PM01	R356		nsp	NN05472610	CHIP RESISTOR	4.7K OHM +- 5% 1/16W
PM01	R357		nsp	NN05103610	CHIP RESISTOR	10K OHM +- 5% 1/16W
PM01	R358		nsp	NN05103610	CHIP RESISTOR	10K OHM +- 5% 1/16W
PM01	R359		nsp	NN05101610	CHIP RESISTOR	100 OHM +- 5% 1/16W
PM01	R360		nsp	NN05101610	CHIP RESISTOR	100 OHM +- 5% 1/16W
PM01	R361		nsp	NN05101610	CHIP RESISTOR	100 OHM +- 5% 1/16W
PM01	R362		nsp	NN05101610	CHIP RESISTOR	100 OHM +- 5% 1/16W
PM01	R363		nsp	NN05101610	CHIP RESISTOR	100 OHM +- 5% 1/16W
PM01	R364		nsp	NN05101610	CHIP RESISTOR	100 OHM +- 5% 1/16W
PM01	R365		NI05000110	NI05000110	CHIP RESISTOR	0 OHM +- 5% 1/10W
PM01	R367		nsp	NN05104610	CHIP RESISTOR	100K OHM +- 5% 1/16W
PM01	R368		nsp	NN05104610	CHIP RESISTOR	100K OHM +- 5% 1/16W
PM01	R369		nsp	NN05102610	CHIP RESISTOR	1K OHM +- 5% 1/16W
PM01	R370		nsp	NN05102610	CHIP RESISTOR	1K OHM +- 5% 1/16W
PM01	R379		nsp	NN05224610	CHIP RESISTOR	220K OHM +- 5% 1/16W
PM01	R380		nsp	NN05224610	CHIP RESISTOR	220K OHM +- 5% 1/16W
PM01	R381		nsp	NN05222610	CHIP RESISTOR	2.2K OHM +- 5% 1/16W
PM01	R382		nsp	NN05472610	CHIP RESISTOR	4.7K OHM +- 5% 1/16W
PM01	R401		nsp	NN05393610	CHIP RESISTOR	39K OHM +- 5% 1/16W
PM01	R402		nsp	NN05393610	CHIP RESISTOR	39K OHM +- 5% 1/16W
PM01	R403		FC90020110	FC90020110	FERRITE CORE	BLM11B601S CHIP FERRITE
PM01	R404		nsp	NN05223610	CHIP RESISTOR	22K OHM +- 5% 1/16W
PM01	R405		nsp	NN05101610	CHIP RESISTOR	100 OHM +- 5% 1/16W
PM01	R406		nsp	NN05000610	CHIP RESISTOR	0 OHM +- 5% 1/16W
PM01	R407		nsp	NN05104610	CHIP RESISTOR	100K OHM +- 5% 1/16W
PM01	R408		nsp	NN05101610	CHIP RESISTOR	100 OHM +- 5% 1/16W
PM01	R409		nsp	NN05223610	CHIP RESISTOR	22K OHM +- 5% 1/16W
PM01	R410		nsp	NN05104610	CHIP RESISTOR	100K OHM +- 5% 1/16W
PM01	R411		nsp	NN05000610	CHIP RESISTOR	0 OHM +- 5% 1/16W
PM01	R412		nsp	NN05000610	CHIP RESISTOR	0 OHM +- 5% 1/16W
PM01	R413		FC90020110	FC90020110	FERRITE CORE	BLM11B601S CHIP FERRITE
PM01	R414		nsp	NN05000610	CHIP RESISTOR	0 OHM +- 5% 1/16W
PM01	R415		nsp	NN05103610	CHIP RESISTOR	10K OHM +- 5% 1/16W
PM01	R416		nsp	NN05100610	CHIP RESISTOR	10 OHM +- 5% 1/16W
PM01	R417		nsp	NN05104610	CHIP RESISTOR	100K OHM +- 5% 1/16W
PM01	R418		nsp	NN05104610	CHIP RESISTOR	100K OHM +- 5% 1/16W
PM01	R421		nsp	NN05000610	CHIP RESISTOR	0 OHM +- 5% 1/16W
PM01	R422		nsp	NN05000610	CHIP RESISTOR	0 OHM +- 5% 1/16W
PM01	R425		NI05183110	NI05183110	CHIP RESISTOR	18K OHM +- 5% 1/10W
PM01	R427		nsp	NN05103610	CHIP RESISTOR	10K OHM +- 5% 1/16W
PM01	R428		nsp	NN05103610	CHIP RESISTOR	10K OHM +- 5% 1/16W
PM01	R429		nsp	NN05103610	CHIP RESISTOR	10K OHM +- 5% 1/16W
PM01	R430		nsp	NN05103610	CHIP RESISTOR	10K OHM +- 5% 1/16W
PM01	R432		FC90020110	FC90020110	FERRITE CORE	BLM11B601S CHIP FERRITE
PM01	R433		FC90020110	FC90020110	FERRITE CORE	BLM11B601S CHIP FERRITE
PM01	R434		nsp	NN05100610	CHIP RESISTOR	10 OHM +- 5% 1/16W
PM01	R435		nsp	NN05101610	CHIP RESISTOR	100 OHM +- 5% 1/16W
PM01	R436		FC90020110	FC90020110	FERRITE CORE	BLM11B601S CHIP FERRITE
PM01	R437		nsp	NN05103610	CHIP RESISTOR	10K OHM +- 5% 1/16W
PM01	R438		nsp	NN05102610	CHIP RESISTOR	1K OHM +- 5% 1/16W
PM01	R801		nsp	NN05104610	CHIP RESISTOR	100K OHM +- 5% 1/16W
PM01	R802		NH05010140	NH05010140	FUSIBLE RESIST	1 OHM J 1/4W
PM01	R803		nsp	NN05473610	CHIP RESISTOR	47K OHM +- 5% 1/16W
PM01	R804		nsp	NN05273610	CHIP RESISTOR	27K OHM +- 5% 1/16W

NOTE : "nsp" PARTS IS LISTED FOR REFERENCE ONLY, MARANTZ WILL NOT SUPPLY THESE PARTS.

P.C.B. NAME	POS. NO.	VERS. COLOR	PART NO. (FOR EUR)	PART NO. (MJI)	PART NAME	DESCRIPTION
PM01	R805		nsp	NN05223610	CHIP RESISTOR	100K OHM +- 5% 1/16W
PM01	R806		nsp	NN05223610	CHIP RESISTOR	22K OHM +- 5% 1/16W
PM01	R808		NI05000110	NI05000110	CHIP RESISTOR	0 OHM +- 5% 1/10W
PM01	R811		NI05000110	NI05000110	CHIP RESISTOR	0 OHM +- 5% 1/10W
PM01	R816		nsp	NN05104610	CHIP RESISTOR	100K OHM +- 5% 1/16W
PM01	R817		nsp	NN05103610	CHIP RESISTOR	10K OHM +- 5% 1/16W
PM01	R818		nsp	NN05104610	CHIP RESISTOR	100K OHM +- 5% 1/16W
PM01	R819		nsp	NN05221610	CHIP RESISTOR	220 OHM +- 5% 1/16W
PM01	R820		nsp	NN05104610	CHIP RESISTOR	100K OHM +- 5% 1/16W
PM01	R821		nsp	NN05221610	CHIP RESISTOR	220 OHM +- 5% 1/16W
PM01	R822		nsp	NN05104610	CHIP RESISTOR	100K OHM +- 5% 1/16W
PM01	R823		nsp	NN05105610	CHIP RESISTOR	1M OHM +- 5% 1/16W
PM01	R825		nsp	NN05104610	CHIP RESISTOR	100K OHM +- 5% 1/16W
PM01	R826		NI01103110	NI01103110	CHIP RESISTOR	10K OHM +- 1% 1/10W
PM01	R827		nsp	NN05102610	CHIP RESISTOR	1K OHM +- 5% 1/16W
PM01	R828		nsp	NN05104610	CHIP RESISTOR	100K OHM +- 5% 1/16W
PM01	R829		NI01152110	NI01152110	CHIP RESISTOR	1.5K OHM +- 1% 1/10W
PM01	R830		nsp	NN05104610	CHIP RESISTOR	100K OHM +- 5% 1/16W
PM01	R832		nsp	NN05221610	CHIP RESISTOR	220 OHM +- 5% 1/16W
PM01	R833		nsp	NN05103610	CHIP RESISTOR	10K OHM +- 5% 1/16W
PM01	R835		nsp	NN05102610	CHIP RESISTOR	1K OHM +- 5% 1/16W
PM01	R836		NI01103110	NI01103110	CHIP RESISTOR	10K OHM +- 1% 1/10W
PM01	R837		nsp	NN05221610	CHIP RESISTOR	220 OHM +- 5% 1/16W
PM01	R838		nsp	NN05472610	CHIP RESISTOR	4.7K OHM +- 5% 1/16W
PM01	R840		NI01103110	NI01103110	CHIP RESISTOR	10K OHM +- 1% 1/10W
PM01	R841		nsp	NN05000610	CHIP RESISTOR	0 OHM +- 5% 1/16W
PM01	R843		nsp	NN05104610	CHIP RESISTOR	100K OHM +- 5% 1/16W
PM01	R844		nsp	NN05473610	CHIP RESISTOR	47K OHM +- 5% 1/16W
PM01	R845		nsp	NN05471610	CHIP RESISTOR	470 OHM +- 5% 1/16W
PM01	R846		NI01153110	NI01153110	CHIP RESISTOR	15K OHM +- 1% 1/10W
PM01	R848		nsp	NN05000610	CHIP RESISTOR	0 OHM +- 5% 1/16W
PM01	R849		nsp	NN05104610	CHIP RESISTOR	100K OHM +- 5% 1/16W
PM01	R850		nsp	NN05104610	CHIP RESISTOR	100K OHM +- 5% 1/16W
PM01	R851		NI05000110	NI05000110	CHIP RESISTOR	0 OHM +- 5% 1/10W
PM01	R852		nsp	NN05103610	CHIP RESISTOR	10K OHM +- 5% 1/16W
PM01	R853		nsp	NN05104610	CHIP RESISTOR	100K OHM +- 5% 1/16W
PM01	R854		NI01103110	NI01103110	CHIP RESISTOR	10K OHM +- 1% 1/10W
PM01	R855		NI01103110	NI01103110	CHIP RESISTOR	10K OHM +- 1% 1/10W
PM01	R856		nsp	NN05471610	CHIP RESISTOR	470 OHM +- 5% 1/16W
PM01	R858		nsp	NN05000610	CHIP RESISTOR	0 OHM +- 5% 1/16W
PM01	R859		NI05000110	NI05000110	CHIP RESISTOR	0 OHM +- 5% 1/10W
PM01	R860		nsp	NN05104610	CHIP RESISTOR	100K OHM +- 5% 1/16W
PM01	R861		NI01103110	NI01103110	CHIP RESISTOR	10K OHM +- 1% 1/10W
PM01	R863		NI01152110	NI01152110	CHIP RESISTOR	1.5K OHM +- 1% 1/10W
PM01	R864		NI01103110	NI01103110	CHIP RESISTOR	10K OHM +- 1% 1/10W
PM01	R865		nsp	NN05103610	CHIP RESISTOR	10K OHM +- 5% 1/16W
PM01	R866		nsp	NN05224610	CHIP RESISTOR	220K OHM +- 5% 1/16W
PM01	R868		nsp	NN05223610	CHIP RESISTOR	22K OHM +- 5% 1/16W
PM01	R869		NI01223110	NI01223110	CHIP RESISTOR	22K OHM +- 1% 1/10W
PM01	R871		nsp	NN05104610	CHIP RESISTOR	100K OHM +- 5% 1/16W
PM01	R872		nsp	NN05393610	CHIP RESISTOR	39K OHM +- 5% 1/16W
PM01	R873		NI01103110	NI01103110	CHIP RESISTOR	10K OHM +- 1% 1/10W
PM01	R875		nsp	NN05472610	CHIP RESISTOR	4.7K OHM +- 5% 1/16W
PM01	R876		nsp	NN05102610	CHIP RESISTOR	1K OHM +- 5% 1/16W
PM01	R878		nsp	NN05183610	CHIP RESISTOR	18K OHM +- 5% 1/16W
PM01	R879		nsp	NN05473610	CHIP RESISTOR	47K OHM +- 5% 1/16W
PM01	R880		nsp	NN05152610	CHIP RESISTOR	1.5K OHM +- 5% 1/16W
PM01	R881		nsp	NN05104610	CHIP RESISTOR	100K OHM +- 5% 1/16W
PM01	R883		nsp	NN05103610	CHIP RESISTOR	10K OHM +- 5% 1/16W
PM01	R884		NI01222110	NI01222110	CHIP RESISTOR	2.2K OHM +- 1% 1/10W
PM01	R885		nsp	NN05102610	CHIP RESISTOR	1K OHM +- 5% 1/16W
PM01	R886		NI01103110	NI01103110	CHIP RESISTOR	10K OHM +- 1% 1/10W
PM01	R887		nsp	NN05473610	CHIP RESISTOR	47K OHM +- 5% 1/16W
PM01	R889		nsp	NN05104610	CHIP RESISTOR	100K OHM +- 5% 1/16W
PM01	R890		nsp	NN05103610	CHIP RESISTOR	10K OHM +- 5% 1/16W
PM01	R893		nsp	NN05104610	CHIP RESISTOR	100K OHM +- 5% 1/16W
PM01	R894		nsp	NN05472610	CHIP RESISTOR	4.7K OHM +- 5% 1/16W
PM01	R895		nsp	NN05104610	CHIP RESISTOR	100K OHM +- 5% 1/16W
PM01	R896		nsp	NN05104610	CHIP RESISTOR	100K OHM +- 5% 1/16W
PM01	R897		nsp	NN05103610	CHIP RESISTOR	10K OHM +- 5% 1/16W

NOTE : "nsp" PARTS IS LISTED FOR REFERENCE ONLY, MARANTZ WILL NOT SUPPLY THESE PARTS.

P.C.B. NAME	POS. NO.	VERS. COLOR	PART NO. (FOR EUR)	PART NO. (MJI)	PART NAME	DESCRIPTION
PM01	R898		NI05182110	NI05182110	CHIP RESISTOR	1.8K OHM +- 5% 1/10W
PM01	R900		nsp	NN05393610	CHIP RESISTOR	39K OHM +- 5% 1/16W
PM01	R901		nsp	NN05103610	CHIP RESISTOR	10K OHM +- 5% 1/16W
PM01	R902		nsp	NN05104610	CHIP RESISTOR	100K OHM +- 5% 1/16W
PM01	R903		nsp	NN05472610	CHIP RESISTOR	4.7K OHM +- 5% 1/16W
PM01	R904		NI01183110	NI01183110	CHIP RESISTOR	18K OHM +- 1% 1/10W
PM01	R907		nsp	NN05104610	CHIP RESISTOR	100K OHM +- 5% 1/16W
PM01	R910		nsp	NN05183610	CHIP RESISTOR	18K OHM +- 5% 1/16W
PM01	R911		NI01102110	NI01102110	CHIP RESISTOR	1K OHM +- 1% 1/10W
PM01	R914		NI01683110	NI01683110	CHIP RESISTOR	68K OHM +- 1% 1/10W
PM01	R915		nsp	NN05471610	CHIP RESISTOR	470 OHM +- 5% 1/16W
PM01	R916		nsp	NN05104610	CHIP RESISTOR	100K OHM +- 5% 1/16W
PM01	R917		nsp	NN05103610	CHIP RESISTOR	10K OHM +- 5% 1/16W
PM01	R918		nsp	NN05102610	CHIP RESISTOR	1K OHM +- 5% 1/16W
PM01	R920		nsp	NN05105610	CHIP RESISTOR	1M OHM +- 5% 1/16W
PM01	R921		nsp	NN05105610	CHIP RESISTOR	1M OHM +- 5% 1/16W
PM01	R922		nsp	NN05105610	CHIP RESISTOR	1M OHM +- 5% 1/16W
PM01	R923		nsp	NN05472610	CHIP RESISTOR	4.7K OHM +- 5% 1/16W
PM01	R924		NI05000110	NI05000110	CHIP RESISTOR	0 OHM +- 5% 1/10W
PM01	R925		nsp	NN05102610	CHIP RESISTOR	1K OHM +- 5% 1/16W
PM01	R926		nsp	NN05103610	CHIP RESISTOR	10K OHM +- 5% 1/16W
PM01	RB01		nsp	NN05103610	CHIP RESISTOR	10K OHM +- 5% 1/16W
PM01	RB02		nsp	NN05103610	CHIP RESISTOR	10K OHM +- 5% 1/16W
PM01	RB03		nsp	NN05332610	CHIP RESISTOR	3.3K OHM +- 5% 1/16W
PM01	RB04		nsp	NN05103610	CHIP RESISTOR	10K OHM +- 5% 1/16W
PM01	RB05		nsp	NN05103610	CHIP RESISTOR	10K OHM +- 5% 1/16W
PM01	RB06		nsp	NN05472610	CHIP RESISTOR	4.7K OHM +- 5% 1/16W
PM01	RB07		nsp	NN05332610	CHIP RESISTOR	3.3K OHM +- 5% 1/16W
PM01	RB08		nsp	NN05104610	CHIP RESISTOR	100K OHM +- 5% 1/16W
PM01	RB24		nsp	NN05224610	CHIP RESISTOR	220K OHM +- 5% 1/16W
PM01	RB25		nsp	NN05224610	CHIP RESISTOR	220K OHM +- 5% 1/16W
PM01	RB26		nsp	NN05224610	CHIP RESISTOR	220K OHM +- 5% 1/16W
PM01	RB28		nsp	NN05101610	CHIP RESISTOR	100 OHM +- 5% 1/16W
PM01	RB30		nsp	NN05104610	CHIP RESISTOR	100K OHM +- 5% 1/16W
PM01	RB31		nsp	NN05101610	CHIP RESISTOR	100 OHM +- 5% 1/16W
PM01	RB33		nsp	NN05104610	CHIP RESISTOR	100K OHM +- 5% 1/16W
PM01	RB34		nsp	NN05104610	CHIP RESISTOR	100K OHM +- 5% 1/16W
PM01	RB35		nsp	NN05104610	CHIP RESISTOR	100K OHM +- 5% 1/16W
PM01	RB36		nsp	NN05104610	CHIP RESISTOR	100K OHM +- 5% 1/16W
PM01	RB37		nsp	NN05104610	CHIP RESISTOR	100K OHM +- 5% 1/16W
PM01	RB39		RI05221010	RI05221010	CHIP RESISTOR	220 OHM J 1W
PM01	RB40		RI05221010	RI05221010	CHIP RESISTOR	220 OHM J 1W
PM01	RB41		nsp	NN05104610	CHIP RESISTOR	100K OHM +- 5% 1/16W
PM01	RB42		nsp	NN05104610	CHIP RESISTOR	100K OHM +- 5% 1/16W
PM01	RB51		nsp	NN05103610	CHIP RESISTOR	10K OHM +- 5% 1/16W
PM01	RB52		nsp	NN05103610	CHIP RESISTOR	10K OHM +- 5% 1/16W
PM01	RB53		nsp	NN05333610	CHIP RESISTOR	33K OHM +- 5% 1/16W
PM01	RB54		nsp	NN05333610	CHIP RESISTOR	33K OHM +- 5% 1/16W
PM01	RB61		nsp	NN05000610	CHIP RESISTOR	0 OHM +- 5% 1/16W
PM01	RB62		nsp	NN05000610	CHIP RESISTOR	0 OHM +- 5% 1/16W
PM01	RD01		nsp	NN05000610	CHIP RESISTOR	0 OHM +- 5% 1/16W
PM01	RD03		nsp	NN05472610	CHIP RESISTOR	4.7K OHM +- 5% 1/16W
PM01	RD04		nsp	NN05000610	CHIP RESISTOR	0 OHM +- 5% 1/16W
PM01	RD05		FC90020110	FC90020110	FERRITE CORE	BLM11B601S CHIP FERRITE
PM01	RD06		nsp	NN05000610	CHIP RESISTOR	0 OHM +- 5% 1/16W
PM01	RD07		nsp	NN05102610	CHIP RESISTOR	1K OHM +- 5% 1/16W
PM01	RD08		nsp	NN05472610	CHIP RESISTOR	4.7K OHM +- 5% 1/16W
PM01	RD09		nsp	NN05000610	CHIP RESISTOR	0 OHM +- 5% 1/16W
PM01	RD10		nsp	NN05330610	CHIP RESISTOR	33 OHM +- 5% 1/16W
PM01	RD11		nsp	NN05103610	CHIP RESISTOR	10K OHM +- 5% 1/16W
PM01	RD12		nsp	NN05103610	CHIP RESISTOR	10K OHM +- 5% 1/16W
PM01	RD13		nsp	NN05103610	CHIP RESISTOR	10K OHM +- 5% 1/16W
PM01	RD14		nsp	NN05000610	CHIP RESISTOR	0 OHM +- 5% 1/16W
PM01	RD15		nsp	NN05000610	CHIP RESISTOR	0 OHM +- 5% 1/16W
PM01	RD16		FC90020110	FC90020110	FERRITE CORE	BLM11B601S CHIP FERRITE
PM01	RD17		nsp	NN05000610	CHIP RESISTOR	0 OHM +- 5% 1/16W
PM01	RD18		nsp	NN05103610	CHIP RESISTOR	10K OHM +- 5% 1/16W
PM01	RD19		FC90020110	FC90020110	FERRITE CORE	BLM11B601S CHIP FERRITE
PM01	RD20		FC90020110	FC90020110	FERRITE CORE	BLM11B601S CHIP FERRITE
PM01	RD21		FC90020110	FC90020110	FERRITE CORE	BLM11B601S CHIP FERRITE

NOTE : "nsp" PARTS IS LISTED FOR REFERENCE ONLY, MARANTZ WILL NOT SUPPLY THESE PARTS.

P.C.B. NAME	POS. NO.	VERS. COLOR	PART NO. (FOR EUR)	PART NO. (MJI)	PART NAME	DESCRIPTION
PM01	RD22		FC90020110	FC90020110	FERRITE CORE	BLM11B601S CHIP FERRITE
PM01	RD23		FC90020110	FC90020110	FERRITE CORE	BLM11B601S CHIP FERRITE
PM01	RD24		FN31010030	FN31010030	EMI FILTER	BLM11B102S 1608 EMIFILTER
PM01	RD31		nsp	NN05000610	CHIP RESISTOR	0 OHM +- 5% 1/16W
PM01	RD32		nsp	NN05103610	CHIP RESISTOR	10K OHM +- 5% 1/16W
PM01	RD33		nsp	NN05000610	CHIP RESISTOR	0 OHM +- 5% 1/16W
PM01	RD34		FC90020110	FC90020110	FERRITE CORE	BLM11B601S CHIP FERRITE
PM01	RL01		nsp	NN05473610	CHIP RESISTOR	47K OHM +- 5% 1/16W
PM01	RL02		nsp	NN05473610	CHIP RESISTOR	47K OHM +- 5% 1/16W
PM01	RL03		nsp	NN05153610	CHIP RESISTOR	15K OHM +- 5% 1/16W
PM01	RL04		nsp	NN05153610	CHIP RESISTOR	15K OHM +- 5% 1/16W
PM01	RL05		nsp	NN05682610	CHIP RESISTOR	6.8K OHM +- 5% 1/16W
PM01	RL06		nsp	NN05682610	CHIP RESISTOR	6.8K OHM +- 5% 1/16W
PM01	RL07		nsp	NN05104610	CHIP RESISTOR	100K OHM +- 5% 1/16W
PM01	RL08		nsp	NN05104610	CHIP RESISTOR	100K OHM +- 5% 1/16W
PM01	RL09		nsp	NN05101610	CHIP RESISTOR	100 OHM +- 5% 1/16W
PM01	RL10		nsp	NN05101610	CHIP RESISTOR	100 OHM +- 5% 1/16W
PM01	RL21		nsp	NN05100610	CHIP RESISTOR	10 OHM +- 5% 1/16W
PM01	RL22		nsp	NN05100610	CHIP RESISTOR	10 OHM +- 5% 1/16W
PM01	RL23		nsp	NN05100610	CHIP RESISTOR	10 OHM +- 5% 1/16W
PM01	RL41		nsp	NN05473610	CHIP RESISTOR	47K OHM +- 5% 1/16W
PM01	RL42		nsp	NN05473610	CHIP RESISTOR	47K OHM +- 5% 1/16W
PM01	RP01		nsp	NN05105610	CHIP RESISTOR	1M OHM +- 5% 1/16W
PM01	RP02		nsp	NN05105610	CHIP RESISTOR	1M OHM +- 5% 1/16W
PM01	RP03		nsp	NN05104610	CHIP RESISTOR	100K OHM +- 5% 1/16W
PM01	RP04		FC90020110	FC90020110	FERRITE CORE	BLM11B601S CHIP FERRITE
PM01	RP05		FC90020110	FC90020110	FERRITE CORE	BLM11B601S CHIP FERRITE
PM01	RP06		nsp	NN05100610	CHIP RESISTOR	10 OHM +- 5% 1/16W
PM01	RP10		nsp	NN05470610	CHIP RESISTOR	47 OHM +- 5% 1/16W
PM01	RP11		nsp	NN05470610	CHIP RESISTOR	47 OHM +- 5% 1/16W
PM01	RP12		nsp	NN05470610	CHIP RESISTOR	47 OHM +- 5% 1/16W
PM01	RP13		FC90020110	FC90020110	FERRITE CORE	BLM11B601S CHIP FERRITE
PM01	RP14		FC90020110	FC90020110	FERRITE CORE	BLM11B601S CHIP FERRITE
PM01	RP15		FC90020110	FC90020110	FERRITE CORE	BLM11B601S CHIP FERRITE
PM01	RP16		FC90020110	FC90020110	FERRITE CORE	BLM11B601S CHIP FERRITE
PM01	RP17		FC90020110	FC90020110	FERRITE CORE	BLM11B601S CHIP FERRITE
PM01	RP18		FC90020110	FC90020110	FERRITE CORE	BLM11B601S CHIP FERRITE
PM01	RP19		FC90020110	FC90020110	FERRITE CORE	BLM11B601S CHIP FERRITE
PM01	RP20		FC90020110	FC90020110	FERRITE CORE	BLM11B601S CHIP FERRITE
PM01	RP21		FC90020110	FC90020110	FERRITE CORE	BLM11B601S CHIP FERRITE
PM01	RP22		FC90020110	FC90020110	FERRITE CORE	BLM11B601S CHIP FERRITE
PM01	RP23		FC90020110	FC90020110	FERRITE CORE	BLM11B601S CHIP FERRITE
PM01	RP24		FC90020110	FC90020110	FERRITE CORE	BLM11B601S CHIP FERRITE
PM01	RP25		FC90020110	FC90020110	FERRITE CORE	BLM11B601S CHIP FERRITE
PM01	RU02		nsp	NN05103610	CHIP RESISTOR	10K OHM +- 5% 1/16W
PM01	RU03		nsp	NN05103610	CHIP RESISTOR	10K OHM +- 5% 1/16W
PM01	RU04		nsp	NN05103610	CHIP RESISTOR	10K OHM +- 5% 1/16W
PM01	RU05		nsp	NN05103610	CHIP RESISTOR	10K OHM +- 5% 1/16W
PM01	RU06		nsp	NN05103610	CHIP RESISTOR	10K OHM +- 5% 1/16W
PM01	RU07		nsp	NN05103610	CHIP RESISTOR	10K OHM +- 5% 1/16W
PM01	RU08		nsp	NN05222610	CHIP RESISTOR	2.2K OHM +- 5% 1/16W
PM01	RU09		nsp	NN05103610	CHIP RESISTOR	10K OHM +- 5% 1/16W
PM01	RU10		nsp	NN05100610	CHIP RESISTOR	10 OHM +- 5% 1/16W
PM01	RU11		nsp	NN05000610	CHIP RESISTOR	0 OHM +- 5% 1/16W
PM01	RU12		nsp	NN05103610	CHIP RESISTOR	10K OHM +- 5% 1/16W
PM01	RU13		nsp	NN05100610	CHIP RESISTOR	10 OHM +- 5% 1/16W
PM01	RU14		nsp	NN05222610	CHIP RESISTOR	2.2K OHM +- 5% 1/16W
PM01	RU15		nsp	NN05103610	CHIP RESISTOR	10K OHM +- 5% 1/16W
PM01	RU16		nsp	NN05222610	CHIP RESISTOR	2.2K OHM +- 5% 1/16W
PM01	RU17		nsp	NN05104610	CHIP RESISTOR	100K OHM +- 5% 1/16W
PM01	RU21		nsp	NN05103610	CHIP RESISTOR	10K OHM +- 5% 1/16W
PM01	RU22		nsp	NN05100610	CHIP RESISTOR	10 OHM +- 5% 1/16W
PM01	RU23		nsp	NN05682610	CHIP RESISTOR	6.8K OHM +- 5% 1/16W
PM01	RU24		nsp	NN05100610	CHIP RESISTOR	10 OHM +- 5% 1/16W
PM01	RU25		nsp	NN05103610	CHIP RESISTOR	10K OHM +- 5% 1/16W
PM01	RU27		nsp	NN05680610	CHIP RESISTOR	68 OHM +- 5% 1/16W
PM01	RU28		nsp	NN05103610	CHIP RESISTOR	10K OHM +- 5% 1/16W
PM01	RU29		nsp	NN05472610	CHIP RESISTOR	4.7K OHM +- 5% 1/16W
PM01	RU30		nsp	NN05472610	CHIP RESISTOR	4.7K OHM +- 5% 1/16W
PM01	RU31		nsp	NN05103610	CHIP RESISTOR	10K OHM +- 5% 1/16W

NOTE : "nsp" PARTS IS LISTED FOR REFERENCE ONLY, MARANTZ WILL NOT SUPPLY THESE PARTS.

P.C.B. NAME	POS. NO.	VERS. COLOR	PART NO. (FOR EUR)	PART NO. (MJI)	PART NAME	DESCRIPTION
PM01	RU32		nsp	NN05103610	CHIP RESISTOR	10K OHM +- 5% 1/16W
PM01	RU33		nsp	NN05103610	CHIP RESISTOR	10K OHM +- 5% 1/16W
PM01	RU34		nsp	NN05103610	CHIP RESISTOR	10K OHM +- 5% 1/16W
PM01	RU35		nsp	NN05103610	CHIP RESISTOR	10K OHM +- 5% 1/16W
PM01	RU36		nsp	NN05103610	CHIP RESISTOR	10K OHM +- 5% 1/16W
PM01	RU37		nsp	NN05103610	CHIP RESISTOR	10K OHM +- 5% 1/16W
PM01	RU38		nsp	NN05103610	CHIP RESISTOR	10K OHM +- 5% 1/16W
PM01	RU40		nsp	NN05103610	CHIP RESISTOR	10K OHM +- 5% 1/16W
PM01	RU41		nsp	NN05103610	CHIP RESISTOR	10K OHM +- 5% 1/16W
PM01	RU42		nsp	NN05103610	CHIP RESISTOR	10K OHM +- 5% 1/16W
PM01	RU43		nsp	NN05103610	CHIP RESISTOR	10K OHM +- 5% 1/16W
PM01	RU46		nsp	NN05472610	CHIP RESISTOR	4.7K OHM +- 5% 1/16W
PM01	RU47		nsp	NN05000610	CHIP RESISTOR	0 OHM +- 5% 1/16W
PM01	RU48		nsp	NN05103610	CHIP RESISTOR	10K OHM +- 5% 1/16W
PM01	RU49		nsp	NN05103610	CHIP RESISTOR	10K OHM +- 5% 1/16W
PM01	RU50		nsp	NN05103610	CHIP RESISTOR	10K OHM +- 5% 1/16W
PM01	RU51		nsp	NN05103610	CHIP RESISTOR	10K OHM +- 5% 1/16W
PM01	RU52		nsp	NN05103610	CHIP RESISTOR	10K OHM +- 5% 1/16W
PM01	RU53		nsp	NN05103610	CHIP RESISTOR	10K OHM +- 5% 1/16W
PM01	RU54		nsp	NN05103610	CHIP RESISTOR	10K OHM +- 5% 1/16W
PM01	RU55		nsp	NN05103610	CHIP RESISTOR	10K OHM +- 5% 1/16W
PM01	RU56		RI05561010	RI05561010	CHIP RESISTOR	560 OHM +-5% 1W
PM01	RU57		RI05470010	RI05470010	CHIP RESISTOR	47 OHM +- 5% 1W
PM01	RU60		nsp	NN05333610	CHIP RESISTOR	33K OHM +- 5% 1/16W
PM01	RU61		nsp	NN05102610	CHIP RESISTOR	1K OHM +- 5% 1/16W
PM01	RU62		nsp	NN05102610	CHIP RESISTOR	1K OHM +- 5% 1/16W
PM01	RU63		nsp	NN05102610	CHIP RESISTOR	1K OHM +- 5% 1/16W
PM01	RU64		nsp	NN05102610	CHIP RESISTOR	1K OHM +- 5% 1/16W
PM01	RU65		nsp	NN05102610	CHIP RESISTOR	1K OHM +- 5% 1/16W
PM01	RU66		nsp	NN05102610	CHIP RESISTOR	1K OHM +- 5% 1/16W
PM01	RU68		nsp	NN05101610	CHIP RESISTOR	100 OHM +- 5% 1/16W
PM01	RU69		nsp	NN05101610	CHIP RESISTOR	100 OHM +- 5% 1/16W
PM01	RU71		nsp	NN05103610	CHIP RESISTOR	10K OHM +- 5% 1/16W
PM01	RU72		nsp	NN05103610	CHIP RESISTOR	10K OHM +- 5% 1/16W
PM01	RU73		nsp	NN05103610	CHIP RESISTOR	10K OHM +- 5% 1/16W
PM01	RU74		nsp	NN05103610	CHIP RESISTOR	10K OHM +- 5% 1/16W
PM01	RU75		nsp	NN05103610	CHIP RESISTOR	10K OHM +- 5% 1/16W
PM01	RU76		nsp	NN05103610	CHIP RESISTOR	10K OHM +- 5% 1/16W
PM01	RU77		nsp	NN05103610	CHIP RESISTOR	10K OHM +- 5% 1/16W
PM01	RU79		nsp	NN05000610	CHIP RESISTOR	0 OHM +- 5% 1/16W
PM01	RU81		nsp	NN05103610	CHIP RESISTOR	10K OHM +- 5% 1/16W
PM01	RU82		nsp	NN05103610	CHIP RESISTOR	10K OHM +- 5% 1/16W
PM01	RU83		nsp	NN05103610	CHIP RESISTOR	10K OHM +- 5% 1/16W
PM01	RU85		nsp	NN05000610	CHIP RESISTOR	0 OHM +- 5% 1/16W
PM01	RU87		nsp	NN05000610	CHIP RESISTOR	0 OHM +- 5% 1/16W
PM01	RU88		nsp	NN05000610	CHIP RESISTOR	0 OHM +- 5% 1/16W
PM01	RU91		nsp	NN05103610	CHIP RESISTOR	10K OHM +- 5% 1/16W
PM01	RU92		nsp	NN05103610	CHIP RESISTOR	10K OHM +- 5% 1/16W
PM01	RU93		nsp	NN05473610	CHIP RESISTOR	47K OHM +- 5% 1/16W
PM01	RU94		nsp	NN05473610	CHIP RESISTOR	47K OHM +- 5% 1/16W
PM01	RU95		nsp	NN05473610	CHIP RESISTOR	47K OHM +- 5% 1/16W
PM01	RU96		nsp	NN05103610	CHIP RESISTOR	10K OHM +- 5% 1/16W
PM01	RU97		nsp	NN05103610	CHIP RESISTOR	10K OHM +- 5% 1/16W
PM01	RU98		nsp	NN05152610	CHIP RESISTOR	1.5K OHM +- 5% 1/16W
PM01	RU99		nsp	NN05103610	CHIP RESISTOR	10K OHM +- 5% 1/16W
PM01	RX01		nsp	NN05105610	CHIP RESISTOR	1M OHM +- 5% 1/16W
PM01	RX02		nsp	NN05104610	CHIP RESISTOR	100K OHM +- 5% 1/16W
PM01	RX03		nsp	NN05103610	CHIP RESISTOR	10K OHM +- 5% 1/16W
PM01	RX04		nsp	NN05104610	CHIP RESISTOR	100K OHM +- 5% 1/16W
PM01	RX05		nsp	NN05152610	CHIP RESISTOR	1.5K OHM +- 5% 1/16W
PM01	RX06		nsp	NN05104610	CHIP RESISTOR	100K OHM +- 5% 1/16W
PM01	RX07		nsp	NN05472610	CHIP RESISTOR	4.7K OHM +- 5% 1/16W
PM01	RX11		nsp	NN05102610	CHIP RESISTOR	1K OHM +- 5% 1/16W
PM01	RX12		nsp	NN05102610	CHIP RESISTOR	1K OHM +- 5% 1/16W
PM01	RX14		nsp	NN05103610	CHIP RESISTOR	10K OHM +- 5% 1/16W
PM01	RX15		nsp	NN05104610	CHIP RESISTOR	100K OHM +- 5% 1/16W
PM01	RX16		nsp	NN05103610	CHIP RESISTOR	10K OHM +- 5% 1/16W
PM01	RX17		nsp	NN05104610	CHIP RESISTOR	100K OHM +- 5% 1/16W
PM01	RX18		nsp	NN05103610	CHIP RESISTOR	10K OHM +- 5% 1/16W
PM01	RX19		nsp	NN05104610	CHIP RESISTOR	100K OHM +- 5% 1/16W

NOTE : "nsp" PARTS IS LISTED FOR REFERENCE ONLY, MARANTZ WILL NOT SUPPLY THESE PARTS.

P.C.B. NAME	POS. NO.	VERS. COLOR	PART NO. (FOR EUR)	PART NO. (MJI)	PART NAME	DESCRIPTION
PM01	RX20		nsp	NN05472610	CHIP RESISTOR	4.7K OHM +- 5% 1/16W
PM01	RX21		nsp	NN05472610	CHIP RESISTOR	4.7K OHM +- 5% 1/16W
PM01	RX24		nsp	NN05223610	CHIP RESISTOR	22K OHM +- 5% 1/16W
PM01	RX51		nsp	NN05104610	CHIP RESISTOR	100K OHM +- 5% 1/16W
PM01	RX52		nsp	NN05000610	CHIP RESISTOR	0 OHM +- 5% 1/16W
PM01	RX54		nsp	NN05104610	CHIP RESISTOR	100K OHM +- 5% 1/16W
PM01	RX55		nsp	NN05104610	CHIP RESISTOR	100K OHM +- 5% 1/16W
PM01	RX61		nsp	NN05101610	CHIP RESISTOR	100 OHM +- 5% 1/16W
PM01	RX62		nsp	NN05101610	CHIP RESISTOR	100 OHM +- 5% 1/16W
PM01	XP01		JX11001260	JX11001260	CRYSTAL	11.2896 MHZ CRYSTAL
PM01	XP02		JX12001350	JX12001350	CRYSTAL	12.288MHZ X'TAL (SMD-49)
PM01	XU01		FQ02456010	FQ02456010	CERAMIC VIB.	24.576MHZ CERALOCK
PM01	XU02		JX00002370	JX00002370	CRYSTAL	32.768KHZ X-TAL CM200S TAPING
PM01	XX01		FQ01205040	FQ01205040	CERAMIC VIB.	CSTCE12M0G15-R0 FOR USB1.1
PS01	SS01		SR03030060	SR03030060	ROTARY SWITCH	EC11B20244 V L=15MM (ALPS)
PU81	DU81		HI10109300	HI10109300	L.E.D.	PG1101F GREEN STANLEY
PU81	RU89		nsp	NN05470610	CHIP RESISTOR	47 OHM +- 5% 1/16W
PU81	SU81		SC01010500	SC01010500	SWITCH	SPPB62 DETECTOR SW

NOTE : "nsp" PARTS IS LISTED FOR REFERENCE ONLY, MARANTZ WILL NOT SUPPLY THESE PARTS.

