

For U.S.A., Canada, Europe,  
& Japan model

# marantz *PROFESSIONAL*

## SERVICE MANUAL MODEL PMD580 Network Solid State Recorder

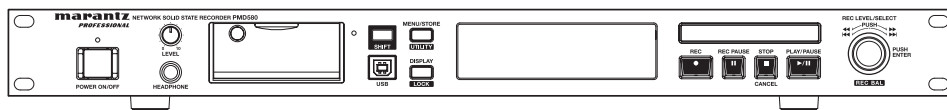

Please use this service manual with referring to the user guide ( D.F.U. ) without fail.  
修理の際は、必ず取扱説明書を準備し操作方法を確認の上作業を行ってください。

**D&M Holdings Inc.**  
PROFESSIONAL BUSINESS COMPANY

KAYABACHO TOWER, 1-21-2 SHINKAWA, CHUO-KU, TOKYO 104-0033 JAPAN  
Telephone : 03 (6731) 5588

<b>SECTION</b>	<b>TABLE OF CONTENTS</b>	<b>PAGE</b>
1. TECHNICAL SPECIFICATIONS.....		1
2. SERVICE MODE .....		2
3. SETTING THE MAC ADDRESS.....		4
4. UPDATING THE FIRMWARE.....		5
5. WIRING DIAGRAM .....		11
6. BLOCK DIAGRAM.....		13
7. SCHEMATIC DIAGRAM.....		15
8. PARTS LOCATION.....		33
9. EXPLODED VIEW AND PARTS LIST .....		53
10. PACKING AND PARTS LIST .....		55
11. IC DATA.....		59
12. ELECTRICAL PARTS LIST .....		77

# 1. TECHNICAL SPECIFICATIONS

## Digital Audio System

System.....Solid State Recorder  
Usable Media.....CF memory cards, Microdrive cards  
Recording and media methods  
MP3.....MPEG1 Layer III compression  
WAV ..... 16/24 bit linear PCM  
Recording MP3 bit rate (selectable)  
Mono ..... 160, 128, 96, 64, 32 kbps  
Stereo..... 320, 256, 192, 128, 64 kbps  
Sampling frequency .....44.1, 48 kHz  
Number of channels ..... 2 (stereo), 1 (mono)  
Audio Frequency response..... 10 to 20,000Hz  $\pm$  1.0 dB  
Signal-to-Noise Ratio IEC-A weighted..... 91 dB  
Total Harmonic Distortion at 0 VU (PCM).....0.01 %  
Dynamic Range ..... 94 dB

## Inputs

### Balanced Input

Type ..... XLR (1:GND, 2:HOT, 3:COLD)  
Input Sensitivity ..... +4 dBu /-20 dBu /24 kohms

### Unbalanced Input

Type ..... RCA jack  
Input Sensitivity ..... 500 mVrms /22 kohms

### UNBALANCED DIGITAL IN

Type ..... RCA jack  
Input impedance..... 75 ohms  
Standard input level ..... 0.5 Vp-p  
Sampling frequency .....44.1 /48 kHz  
Format..... AES/EBU or SPDIF (IEC 958 Type II)

### Balanced Digital Input

Type ..... XLR (1:GND, 2:HOT, 3:COLD)  
Sampling frequency .....44.1 /48 kHz  
Format..... AES/EBU or SPDIF (IEC 958 Type II)

## Outputs

### Balanced output

Type ..... XLR (1:GND, 2:HOT, 3:COLD)  
Level..... +18 dBu (+4dBu reference) /600 ohms

### Unbalanced output

Type ..... RCA jack  
Standard level .....2 Vrms (+4dBu reference) /10 kohms

### Balanced Digital output

Type ..... XLR (1:GND, 2:HOT, 3:COLD)  
Output impedance..... 110 ohms  
Standard output level ..... 3.5 Vp-p  
Format... AES/EBU or SPDIF (IEC 958 Type II) selectable

### Unbalanced Digital output

Type ..... RCA jack  
Output impedance..... 75 ohms  
Standard output level ..... 0.5 Vp-p  
Sampling frequency .....44.1/48 kHz  
Format..... AES/EBU or SPDIF (IEC 958 Type II)

## LAN Interface

Format..... 10Base-T/100Base-TX  
Transmission rate..... 10/100 Mbps  
Connector..... 8pin RJ-45

## General

### Power requirements

US model ..... AC120 V 60 Hz  
European model..... AC100 - 240 V 50/60 Hz  
Japan model..... AC100 V 50/60 Hz

Power consumption (U/N) ..... 26 W

Power consumption (F) ..... 18 W

### Environmental conditions

Operational temperature ..... 5 - 35 °C (41 - 95 °F)  
Operational humidity ..... 25 - 85 %, no condensating  
Storage temperature ..... -20 - 60 °C (-4 - 140 °F)

Headphone Output power ..... 18 mW+18 mW /32 ohms

## Dimensions

Width ..... 483 mm (19.0")  
Height..... 52 mm (2.0")  
Depth..... 344 mm (13.5")  
Weight ..... 3.7 kg (8.2 lbs)

## Included accessories

Power cord (for US) ..... 1  
Power cord (for Europe)..... 2  
Power cord (for Japan)..... 1  
USB cable ..... 1  
Audio cable ..... 2  
CF door Screw. .... 2  
Retainer..... 1  
User Guide ..... 1  
CD-ROM (U/N)..... 1  
Customer Registration Document (only for US)..... 1  
Adapter (for Japan) ..... 1

• Specifications are subject to change without notice.

## 2. SERVICE MODE

Service mode can be performed with the following procedures:

1. Press the **POWER ON/OFF** switch to turn on the power. When the power is turned on, "Booting" then "Initial" then "Loading" appear on the display, followed by the track number and time. Once the display shown below appears, follow the procedures below.

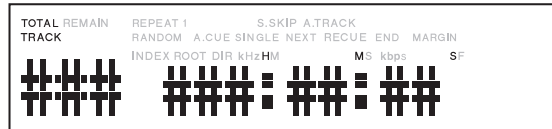

\* If a CF card has not been loaded, "No Card" appears.

※ CFカードが挿入されていないときは、「No Card」が表示されます。

2. If you press and hold both the **STOP/CANCEL** button and **DISPLAY/LOCK** button for several seconds, the unit will enter Service mode.

2. **STOP/CANCEL** ボタンと **DISPLAY/LOCK** ボタンを同時に長押しすると、本機はサービスモードになります。

このとき、以下のように表示します。

The following display appears.



\* In the mode mentioned below, pressing the **STOP/CANCEL** button will cancel the operation. An operation executed by pressing the **Jog wheel** cannot be canceled.

※以下の各モードでは、**STOP/CANCEL** ボタンを押すと操作がキャンセルされます。ジョグダイヤルを押して実行した場合はキャンセルできません。

Turn right the **Jog wheel** one click. ジョグダイヤルを時計方向に1クリック回します。



Press the **Jog wheel** while this display is shown.

All LCD pixels are activated.

表示中にジョグダイヤルを押します。

LCDが全点灯します。

Turn right the **Jog wheel** one click. ジョグダイヤルを時計方向に1クリック回します。



Press the **Jog wheel** while this display is shown.

The LEDs of the level meter, **REC**, **REC PAUSE**, and **PLAY** buttons all light.

表示中にジョグダイヤルを押します。

レベルメータ表示、**REC** ボタン、**REC PAUSE** ボタン、**PLAY** ボタンのLEDが全点灯します。

Turn right the **Jog wheel** one click. ジョグダイヤルを時計方向に1クリック回します。



Press the **Jog wheel** while this display is shown.

表示中にジョグダイヤルを押します。

Turn right the **Jog wheel** one click.

ジョグダイヤルを時計方向に1クリック回します。

The default values for the destination (Europe, United States, or Japan) are set for initialization.

- 1) Select "US" for the United States, "EU" for Europe, or "JP" for Japan.
- 2) Press the **Jog wheel**. A read/write check of the EEPROM is performed, which takes 1 minute. Then the default values for the destination are written to the EEPROM.

各仕向け(ヨーロッパ、アメリカ、日本)によるデフォルト値を設定し、初期化できます。

- ①アメリカ向けの場合は"US"を、ヨーロッパ向けの場合は"EU"を、日本向けの場合は"JP"を選択します。
- ②ジョグダイヤルを押すと、EEPROMのリード・ライト・チェックが約1分間実施され、その後に仕向けに応じたデフォルト値をEEPROMに書き込みます。



Press the **Jog wheel** while this display is shown.

表示中にジョグダイヤルを押します。

Turn right the **Jog wheel** one click.

ジョグダイヤルを時計方向に1クリック回します。

All tracks are played in Repeat All mode.

全トラック繰り返し(Repeat All)モードで再生されます。

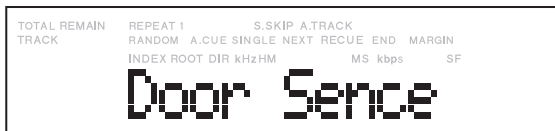

Press the **Jog wheel** while this display is shown.

表示中にジョグダイヤルを押します。

Turn right the **Jog wheel** one click.

ジョグダイヤルを時計方向に1クリック回します。

ENABLE/DISABLE for the sensor of the Card door can be set.

CFカードドアのセンサをENABLE/DISABLEできます。



Press the **Jog wheel** while this display is shown.

表示中にジョグダイヤルを押します。

Turn right the **Jog wheel** one click.

ジョグダイヤルを時計方向に1クリック回します。

The Mac Address can be confirmed.

Mac Addressを確認できます。



Press the **Jog wheel** while this display is shown.

表示中にジョグダイヤルを押します。

Turn right the **Jog wheel** one click.

ジョグダイヤルを時計方向に1クリック回します。

The Mac Address can be set. (See "3. Setting the MAC ADDRESS.")

Mac Addressを設定できます。(3. MACADDRESS設定方法を参照してください。)

(For Japan)

(日本向けのみ)



Press the **Jog wheel** while this display is shown.

表示中にジョグダイヤルを押します。

The lighting condition of the LED of each button can be checked with the special tool connected to the parallel connector.

- **PLAY** button..... The PLAY LED lights.
- **REC** button ..... The REC LED lights.
- **PREVIOUS** button ..... The PLAY LED and Extra2 LED light.
- **NEXT** button ..... The REC LED and Extra1 LED light.
- **EXTRA1** button..... The Extra1 LED lights.
- **EXTRA2** button..... The Extra2 LED lights.
- **STOP** button ..... All LED goes off.

Turn right the **Jog wheel** one click.

ジョグダイヤルを時計方向に1クリック回します。



\*When the **Jog wheel** is turned left, the mode changes in reverse order with each click.

※ジョグダイヤルを反時計方向に1クリック回すごとに逆順でモードが変わります。

パラレル端子に専用治具を接続して、各ボタンLEDの点灯を確認できます。

- **PLAY** ボタン ..... PLAY LED 点灯
- **REC** ボタン ..... REC LED 点灯
- **PREVIOUS** ボタン...PLAY LED / Extra2 LED 点灯
- **NEXT** ボタン ..... REC LED / Extra1 LED 点灯
- **EXTRA1** ボタン ..... Extra1 LED 点灯
- **EXTRA2** ボタン ..... Extra2 LED 点灯
- **STOP** ボタン ..... LED 全消灯

**3.** If the **STOP/CANCEL** button is held pressed for several seconds, the display will return to that previous from Service mode.

**3.** **STOP/CANCEL** ボタンを長押しすると、サービスモードから元の画面に戻ります。

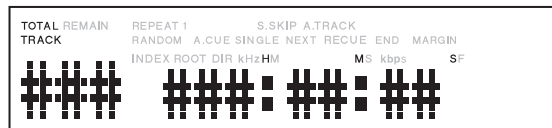

### 3. SETTING THE MAC ADDRESS

Set "Mac Address" in Service mode.

1. Press the **POWER ON/OFF** switch to turn on the power.

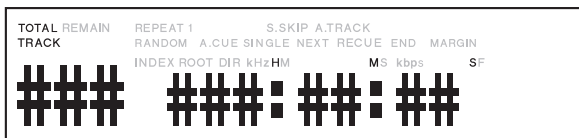

2. If you press and hold both the **STOP/CANCEL** button and **DISPLAY/LOCK** button for several seconds, the unit will enter Service mode.

The following display appears.



Turn right the **Jog wheel** until "Mac Add Set" is displayed, as shown below.



ジョグダイヤルを時計方向に回し、下図の "Mac Add Set" を表示させます。



3. Press the **Jog wheel** with "Mac Add Set" displayed. The following display appears.

3. "Mac Add Set" を表示させた状態で、**ジョグダイヤル**を押します。このとき、以下のように表示します。

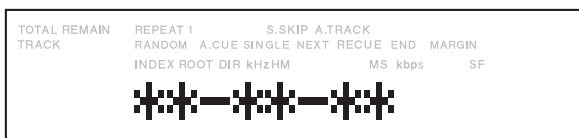

4. Set the Mac Address. Turn the **Jog wheel** until the target digit is set then press the **Jog wheel**.

(Set each digit of the address from left to right in sequence.)

4. 次に、Macアドレスを設定します。**ジョグダイヤル**を回して目的の数字を設定し、**ジョグダイヤル**を押します。

(アドレス設定は、左から順に設定します。)

(Example) When the address is to be set to "91-15-00"

(例)アドレスを "91-15-00" に設定したとき



Once all 6 digits of the Mac Address have been set, press the **Jog wheel**.



Macアドレス(6文字)を設定し終わったら**ジョグダイヤル**を押します。



## 4. UPDATING THE FIRMWARE

The updating method for the PDM580's firmware is common to all destinations. However, after updating, resetting is required for the destination from the "EEPROM" settings in Service mode. For details, see "EEPROM" settings in Service mode.

### Requirements for updating the firmware

- PMD580 to be updated
- CF card
- Personal computer
- Firmware updating file

### Preparations for updating

1. Check the volume of the firmware updating file on your PC. Check the free space of the CF card by accessing it from My Computer of your PC or Windows Explorer.
2. Make sure that there is enough free space for the firmware updating file, and check that there is no old firmware updating file on the CF card.  
If you find the old firmware updating file named "PMD580up.bin" (the filename of the updating file), delete it from the CF card.
3. Copy the new firmware updating file on your PC to the "Root" folder of the CF card. Then it is recommended to check the creation date of the firmware updating file after copying it.  
The filename of the firmware updating file is always "PMD580up.bin."  
  
This completes the preparations for updating the firmware.

## 4. ファームウェアの書き換え

PMD580のファームウェア更新方法については、各仕向けによる違いはありません。ただし、ファームウェアを更新した後にサービスモードの"EEPROM"設定により仕向けごとの再設定をする必要があります。詳しくはサービスモードの"EEPROM"設定をご覧ください。

### ファームウェアの更新作業に必要なもの

- 書き換えたいPMD580
- CFカード
- パーソナル・コンピュータ
- ファームウェア更新用ファイル

### 更新するための前準備

1. ファームウェア更新用ファイルの容量をお手元のパソコンにて確認してください。パソコンのマイコンピュータからアクセスするか、またはプログラムのエクスプローラ等でCFカードの空き容量を確認します。
2. 確認した更新用ファイルの容量に対して十分な空き容量を確保し、CFカードに古い更新用ファイルがないことを確認します。  
ファームウェア更新用ファイル名(更新用ファイル名は常に同じ) "PMD580up.bin" が既に存在するときは、CFカードに書き込まれている同一名ファイルを削除します。
3. パソコン上でファームウェア更新用ファイルをCFカードの"Root"フォルダにコピーします。  
更新用ファイルをCFカードにコピーした後は、更新用ファイルの作成日時を確認することをお勧めします。  
ファームウェア更新用ファイル名(更新用ファイル名は常に同じ)は、"PMD580up.bin"です。  
  
以上でファームウェアの更新する準備が整いました。



## Updating the firmware

Load the prepared CF card into the PMD580 to update the firmware.

1. Insert the CF card to the Card compartment with the PMD580 turned off and close the door. The USB cable should not be connected to the PDM580.
2. Turn the PMD580 on.  
The power indicator (blue) flashes, and after several seconds "Booting" appears on the display.



Then after several tens of seconds, "Initial" then "Loading" appear on the display in sequence, and finally "Update? Yes" appears.



### Note:

Once updating of the firmware begins, it cannot be stopped. During updating, unplugging the AC power cord, turning the power off, opening the Card door, and any action on the operation panel must be avoided, any of which may result in abnormal updating and lead to trouble in operations. If normal updating is aborted, a second attempt may not be possible. Updating of the firmware must be performed carefully.

## ファームウェアの更新作業

前準備したCFカードをPMD580に挿入してファームウェアを更新します。

1. PMD580の電源をOFFにした状態で、前準備したCFカードをCFカード挿入部に挿入し、ドアを閉めます。このときUSBケーブルはPMD580に接続しないでください。
2. PMD580の電源を入れます。  
電源インジケータ(青)が点滅し、数秒後にディスプレイが"Booting"と表示します。

さらに数10秒後、ディスプレイは"Initial" → "Loading"と表示し、最後に"Update? Yes"と表示します。

### 注意:

ファームウェアの更新が一旦始めると途中で停止させることはできません。ファームウェア更新中は電源コードを抜いたり、電源スイッチをOFFしたり、CFカードドアを開けたり、操作パネルを操作したりすると、ファームウェアが正常に更新されず、動作不良になることがあります。そのような行為は絶対に行わないでください。ファームウェアが正常に更新されなかったとき、再更新もできない場合があります。ファームウェア更新作業は操作などを含め十分注意して行ってください。

## Updating procedures





1. To update the firmware, first press the **Jog wheel** with “Update? Yes” displayed.

The following confirmation display appears.

- If the version of the firmware updating file is older than the current one, “Old Ver?” appears.
- If the version of the firmware updating file is the same as the current one, “Same Ver?” appears.

Answer the above prompt, and press the **Jog wheel** again.



Updating of the firmware begins, and  then  then  appear repeatedly at  during updating.

The time required for updating depends on the access speed of the CF card and the volume of the firmware, usually 4 to 5 minutes.

2. When updating is finished, “Finish” momentarily appears on the display, and the Reboot circuit on the main board is activated automatically, which turns the power OFF then ON again. The subsequent procedures are the same as those when turning the power on.

The power indicator (blue) flashes, and after several seconds “Booting” appears on the display.



Then after several tens of seconds, “Initial” and “Loading” appear on the display in sequence, and finally “Update? Yes” appears. A Yes response completes updating of the firmware.



In this mode, the same program can be written repeatedly. To terminate updating of the firmware, follow the procedures below to return to the normal operation mode.

## 更新作業の実施









1. ファームウェアを更新するときは、ディスプレイに “Update? Yes” が表示されている状態で、**ジョグダイヤル**を押してください。

このとき、以下の確認表示が表示されます。

- ファームウェア更新用ファイルが現在本機のファームウェアバージョンより古いとき、“Old Ver?”が表示されます。
- ファームウェア更新用ファイルが現在本機のファームウェアバージョンと同じとき、“Same Ver?”が表示されます。

上記内容確認後に、再度**ジョグダイヤル**を押します。

ファームウェア更新が開始され、更新中は上図のの部分か

 →  →  →  →  →  →  →  → を繰り返し表示します。

更新の時間はCFカードのスピードおよびファームウェアの容量によって異なりますが、目安として約4～5分です。

2. 更新が終了すると、ディスプレイに “Finish” が一瞬表示され、同時にメインボードのReboot回路が自動的に働き、電源OFFからONに切り替わります。以降の動作は電源を入れたときと同じ動作です。

電源インジケータ(青)が点滅し、数秒後にディスプレイが “Booting” と表示します。

さらに数秒後、ディスプレイは “Initial” → “Loading” と表示し、最後に “Update? Yes” と表示します。これでファームウェアの更新が完了となります。

この状態から何度でも同じプログラムを書き込むことは可能です。ファームウェア更新を完全に終了するためには以下の手順にて通常モードに移行してください。

## Terminating updating and returning to the normal mode

1. Turn right the **Jog wheel** one click with “Update? Yes” displayed. “Update? No” appears on the display.



2. Press the **Jog wheel**. “Loading” appears on the display, the Card access light flashes, and the file recorded on the CF card is loaded.



When loading of the file completes, the contents recorded on the CF card appear.

## 更新を終了し通常モードへの移行

1. ディスプレイに “Update? Yes” が表示されている状態で、**ジョグダイヤル**を時計方向に1クリック回します。ディスプレイが “Update? No” に変わります。

2. この状態で**ジョグダイヤル**を押してください。ディスプレイに “Loading” が表示され、CFアクセスランプが点滅しCFカードに記録されているファイルをロードします。

ファイルのロードが完了すると、CFカードに記録したファイルの内容が表示されます。

## Checking the firmware version

In Stop mode, you can check the firmware version with “F/W version” of the Utility menu.

1. Press both the **MENU/STORE** button and the **SHIFT** button in Stop mode. The Utility menu appears on the display.
2. Turn right the **Jog wheel** until “U16 F/W version” is displayed then press the **Jog wheel**.



A version number, such as “ver 1.00,” appears on the display.

(Example: The version number is 1.00)

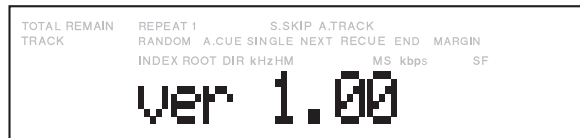

3. Press the **Jog wheel** to restore the previous display.



4. Press the **MENU/STORE** button to return to the normal operation mode from the Utility menu.

## ファームウェアのバージョン確認

停止状態においてユーティリティメニューの“F/W version”によりファームウェアバージョンを確認することができます。

1. 停止状態において、**SHIFT** ボタンを押しながら **MENU/STORE** ボタンを同時に押します。ユーティリティメニューに移行します。ディスプレイには、ユーティリティメニューが表示されます。
2. ジョグダイヤルを時計方向に回して、“U16 F/W version”を表示させ、この状態でジョグダイヤルを押してください。

ディスプレイにバージョン “ver 1.00” が表示されます。

(表示例: Versionが1.00の場合)

3. この状態でジョグダイヤルを押すと、ディスプレイが元に戻ります。

4. ユーティリティメニューから通常モードに戻る場合は **MENU/STORE** ボタンを押します。

5. WIRING DIAGRAM

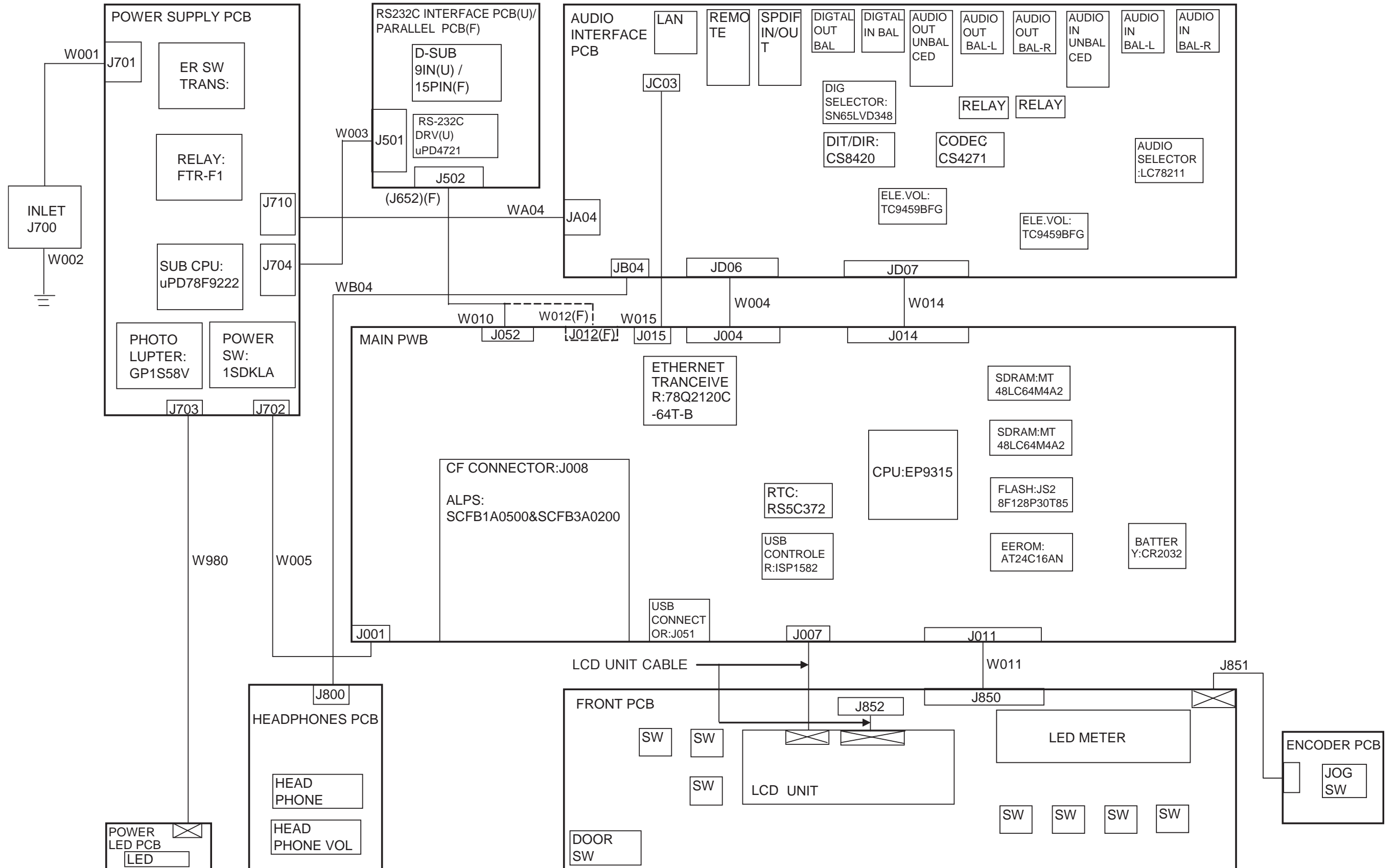

## 6. BLOCK DIAGRAM

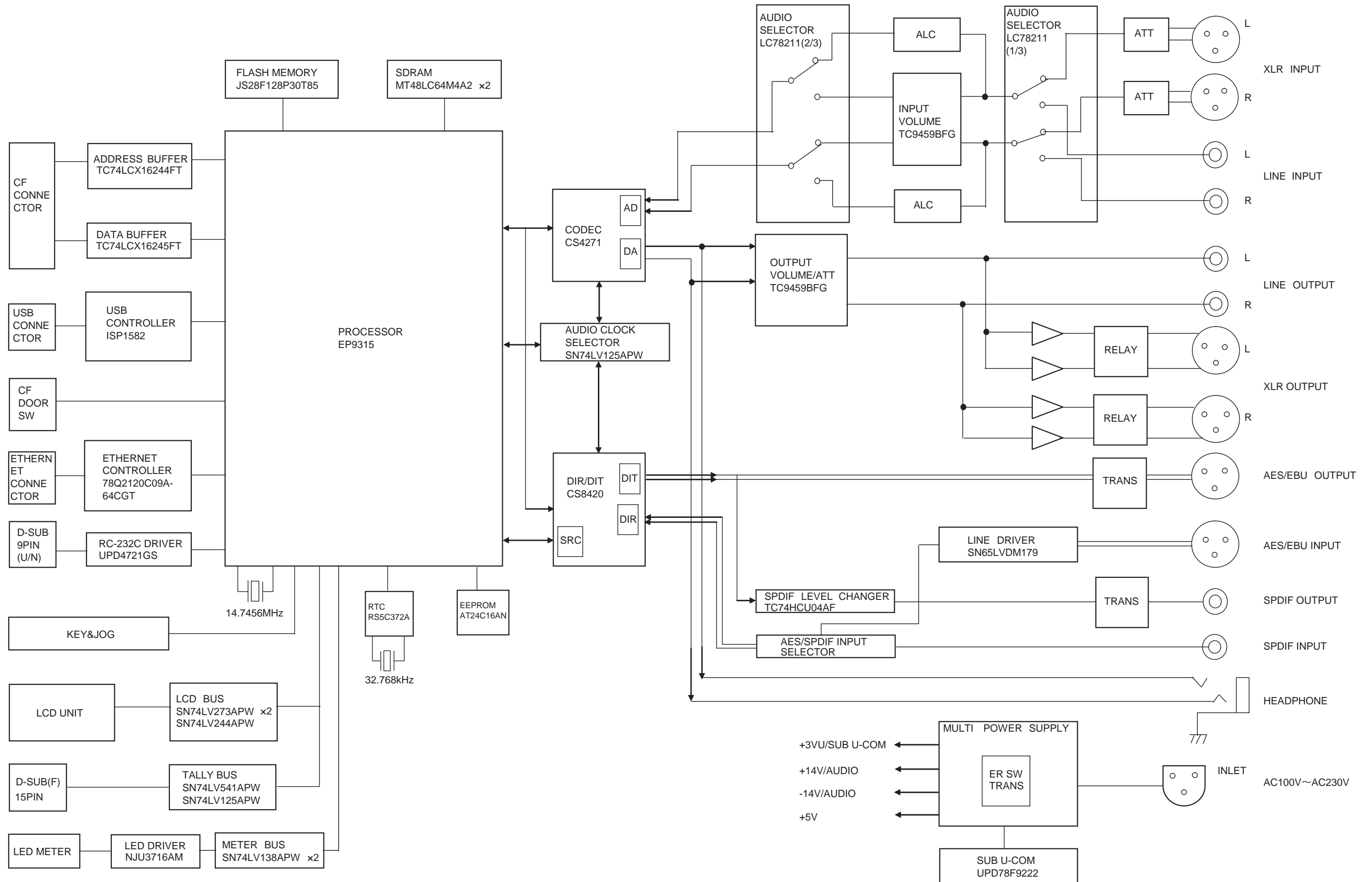

# 7. SCHEMATIC DIAGRAM

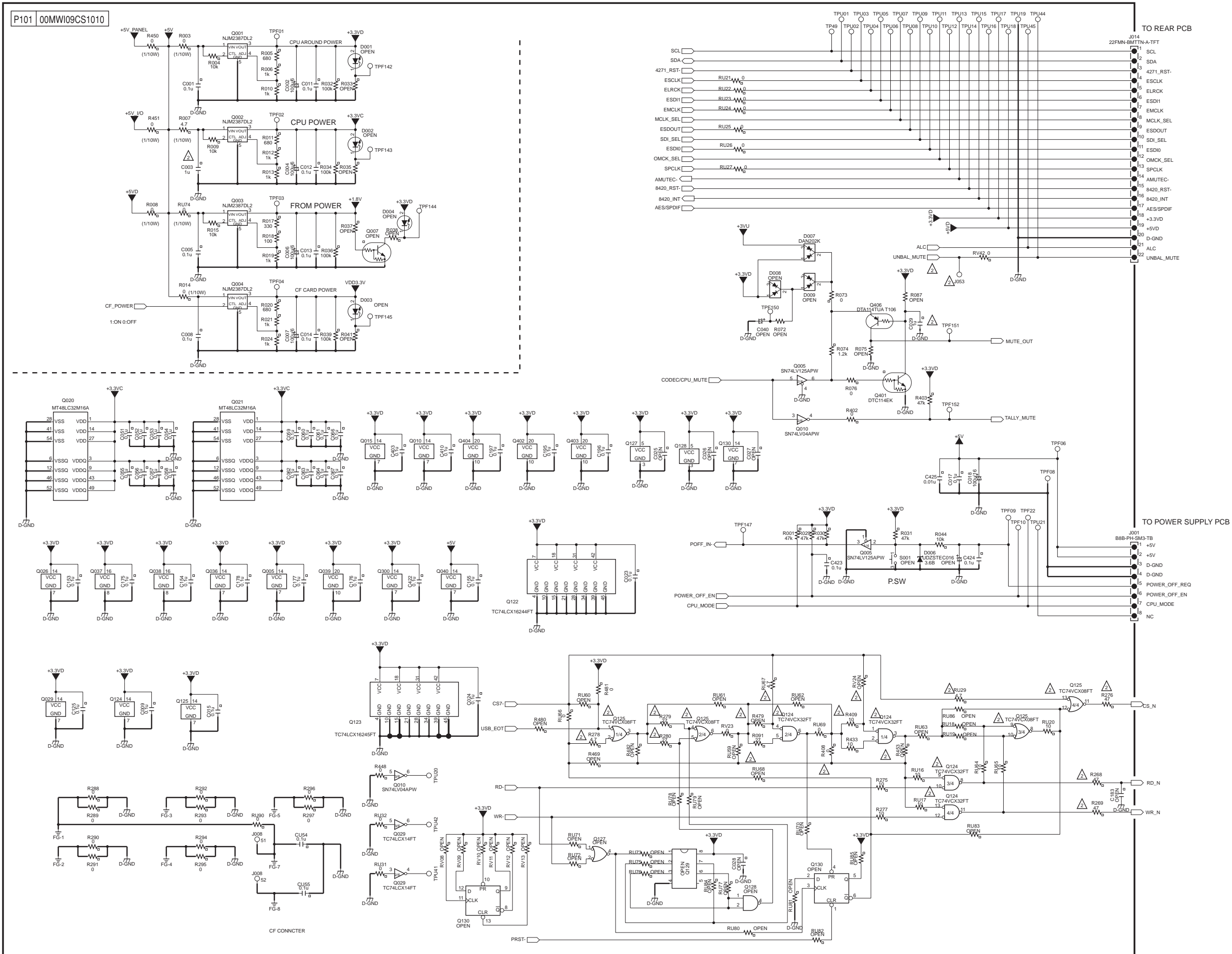

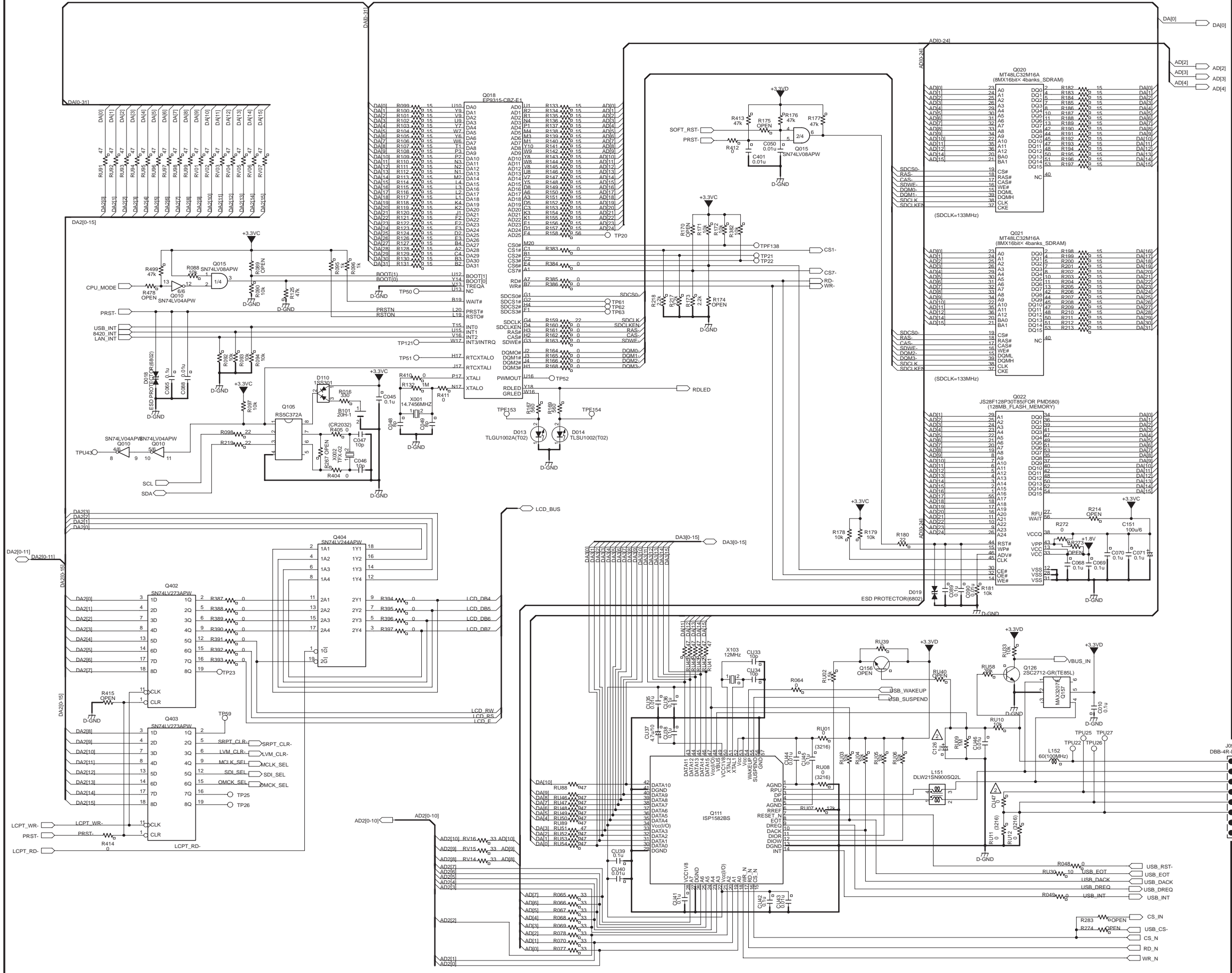



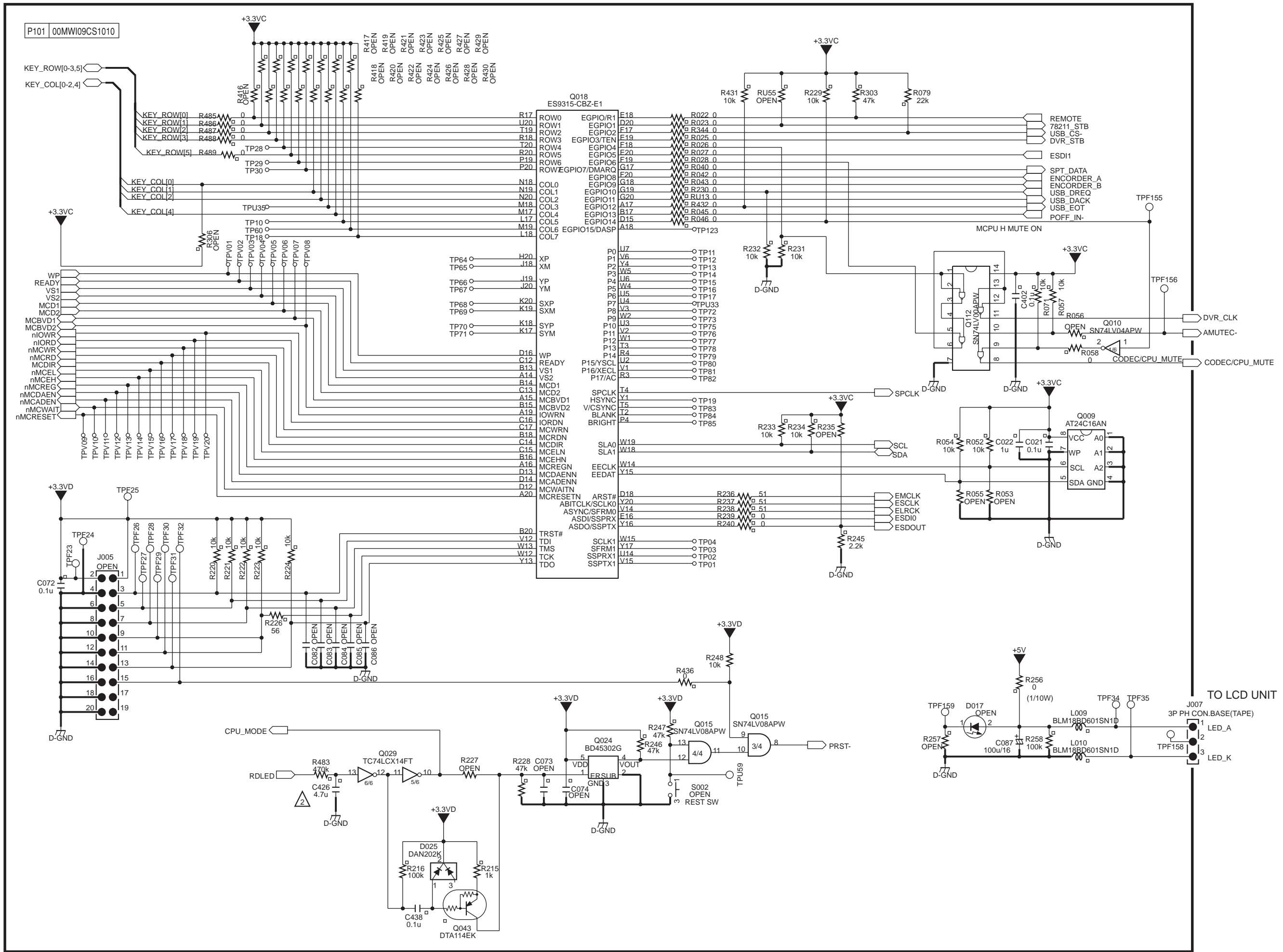



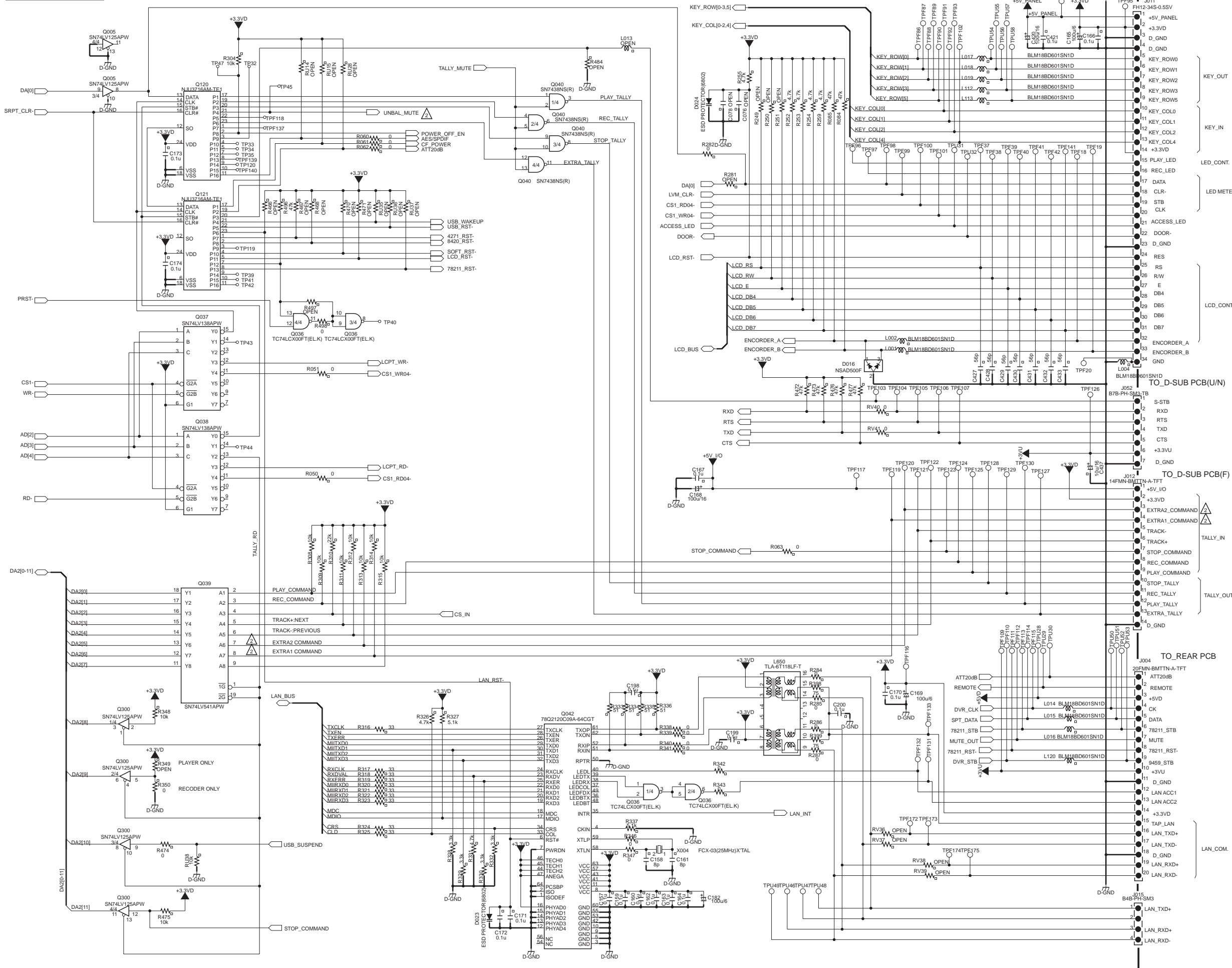

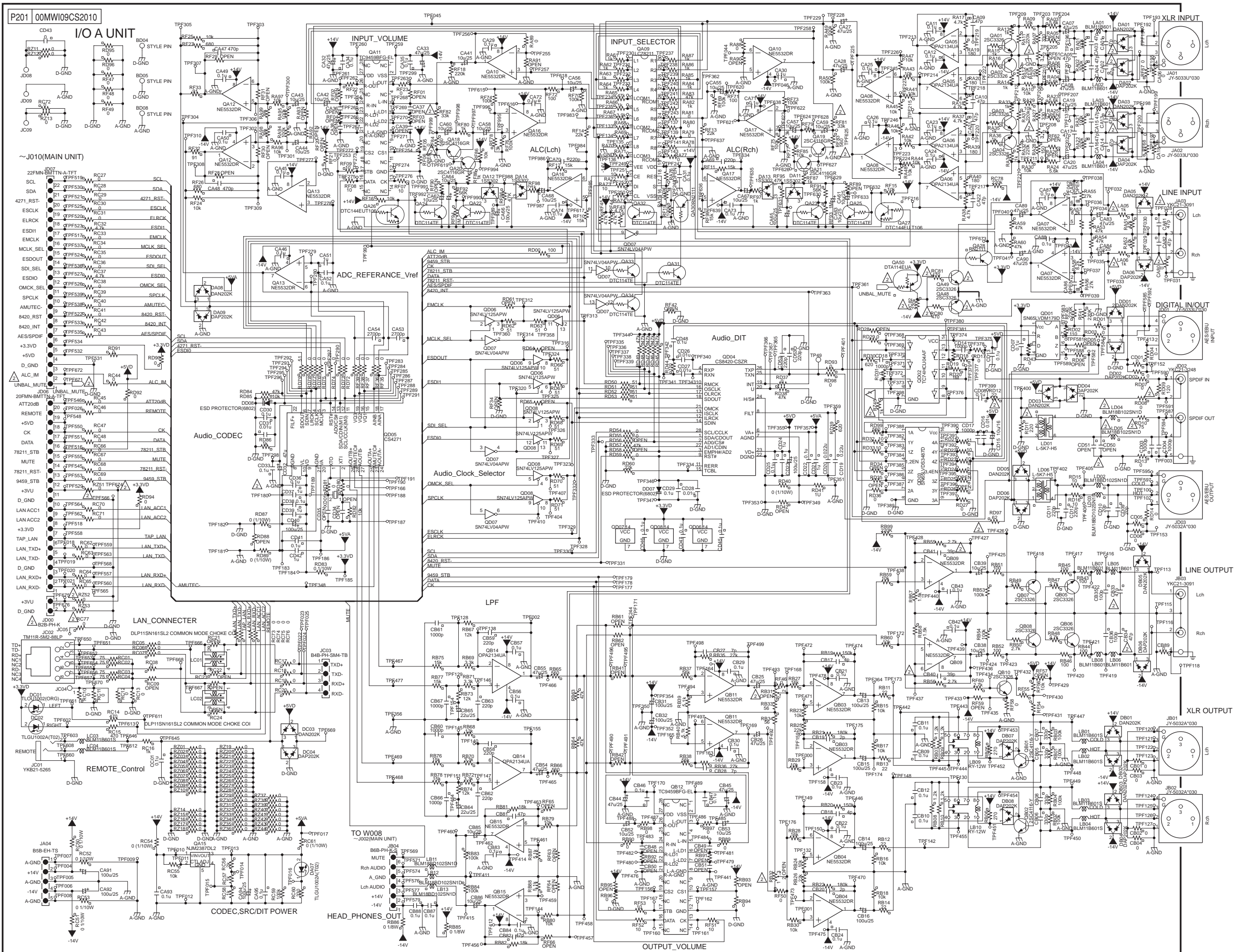

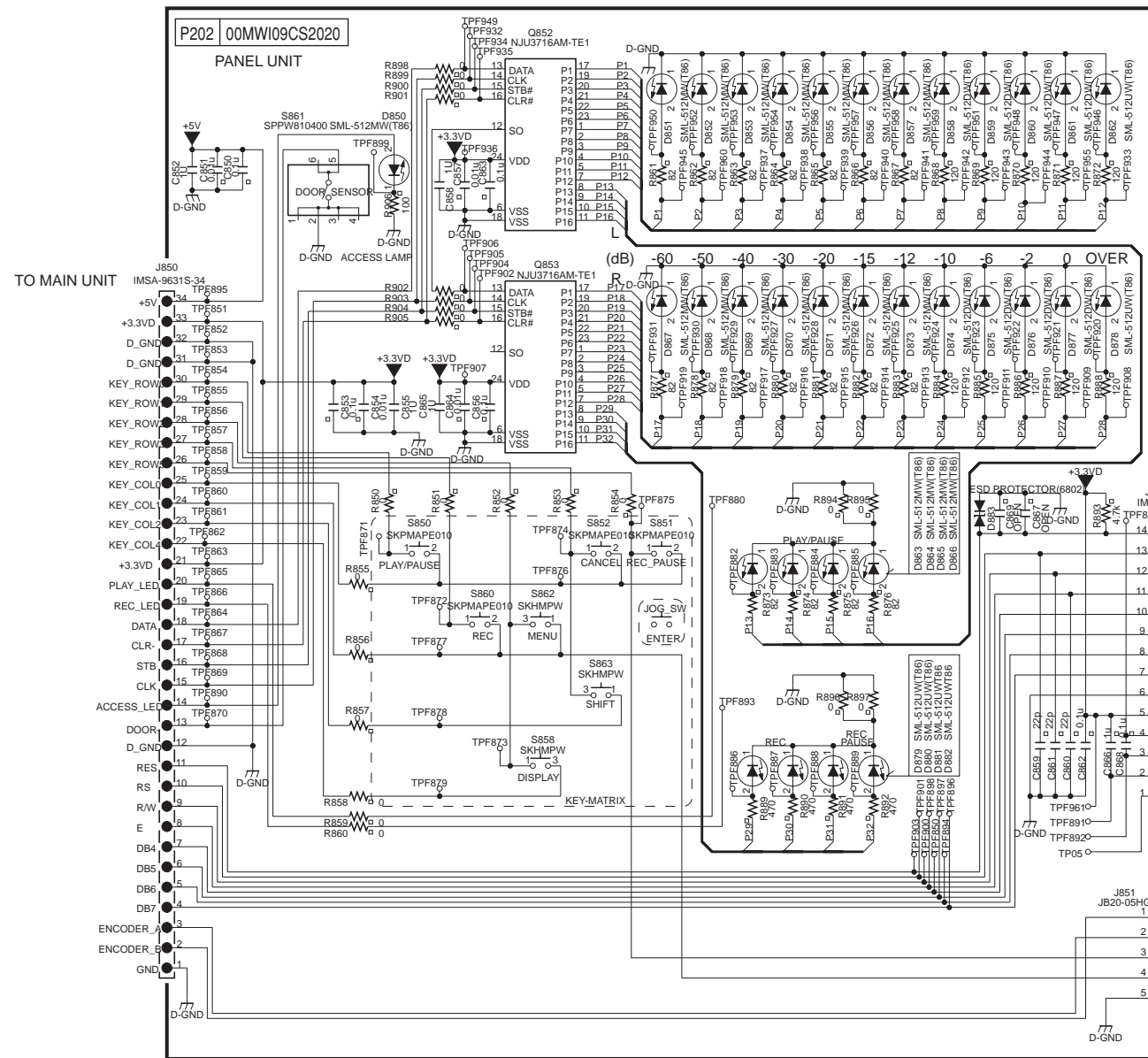

TO MAIN UNIT  
TO W015  
J011 (MAIN UNIT)

TO POWER UNIT  
TO J704

TO LCD UNIT

P204 00MWI09CS2040

J970 JOG UNIT

ENCODER\_B  
ENCODER\_A  
KEY\_ROW5  
KEY\_COL1  
D\_GND

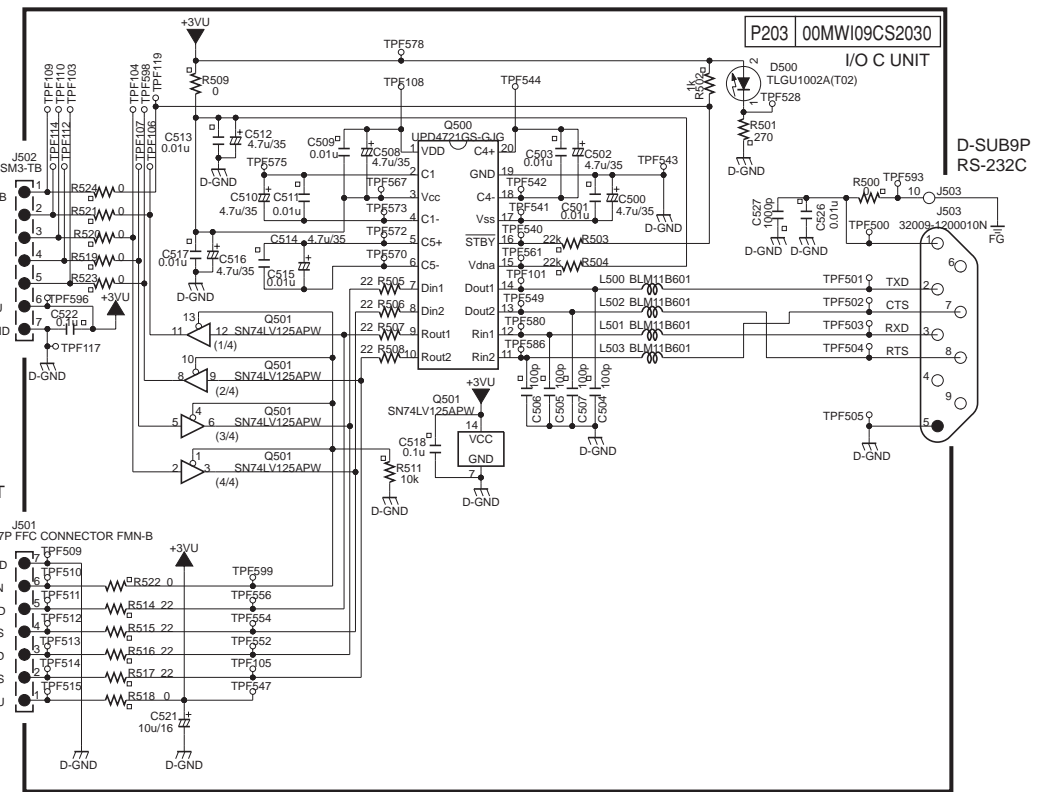

D-SUB9P  
RS-232C

DSUB15P RS232C Control for U/N	
PIN No.	SIGNAL Name
1	Ground
2	TXD
3	RXD
4	NC
5	Signal Ground
6	NC
7	CTS
8	RTS
9	

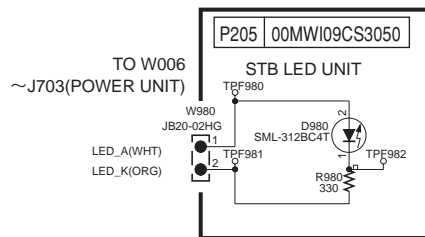

TO W006  
~J703 (POWER UNIT)

STB LED UNIT

LED\_A(WHT)  
LED\_K(ORG)

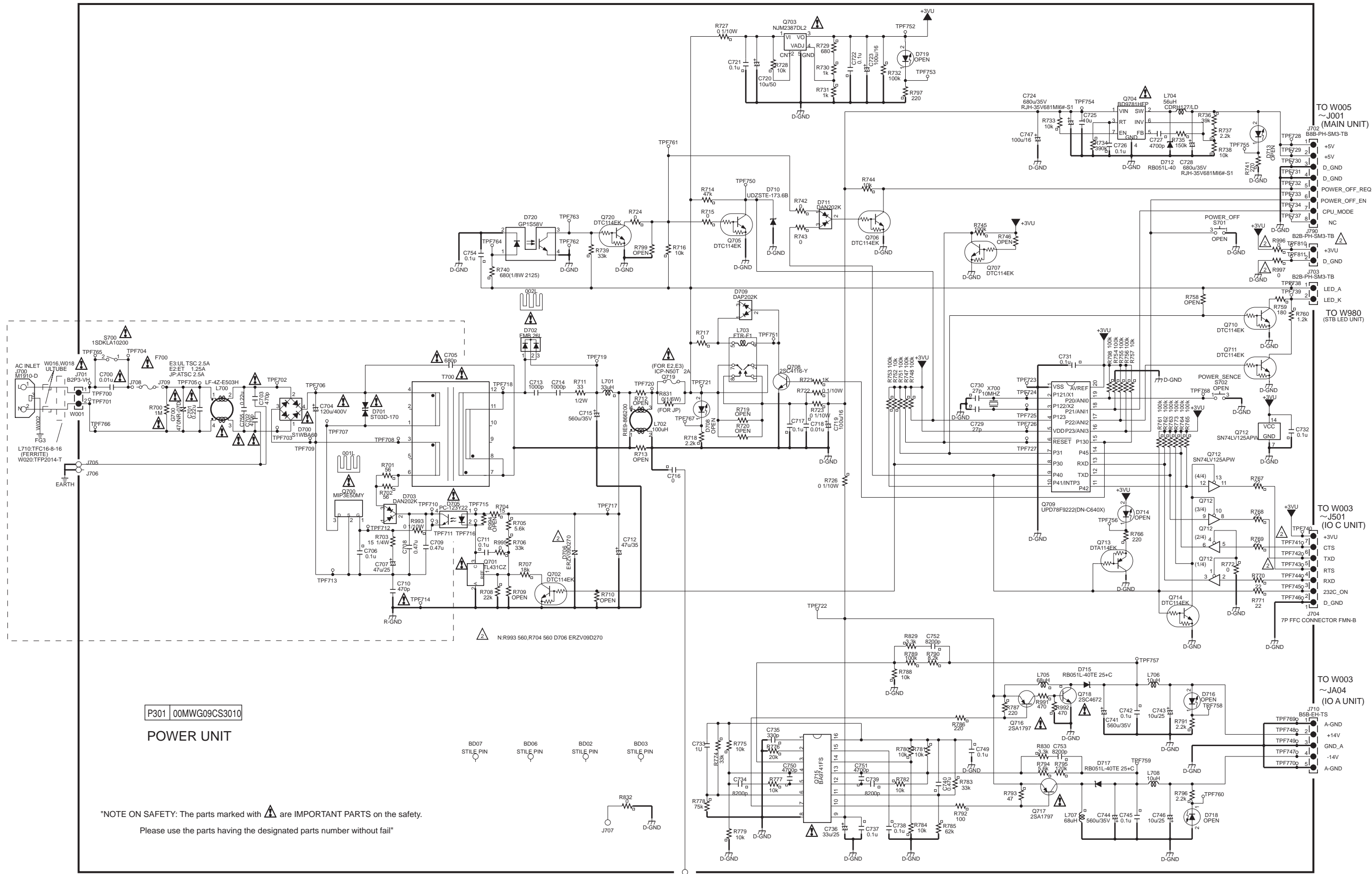

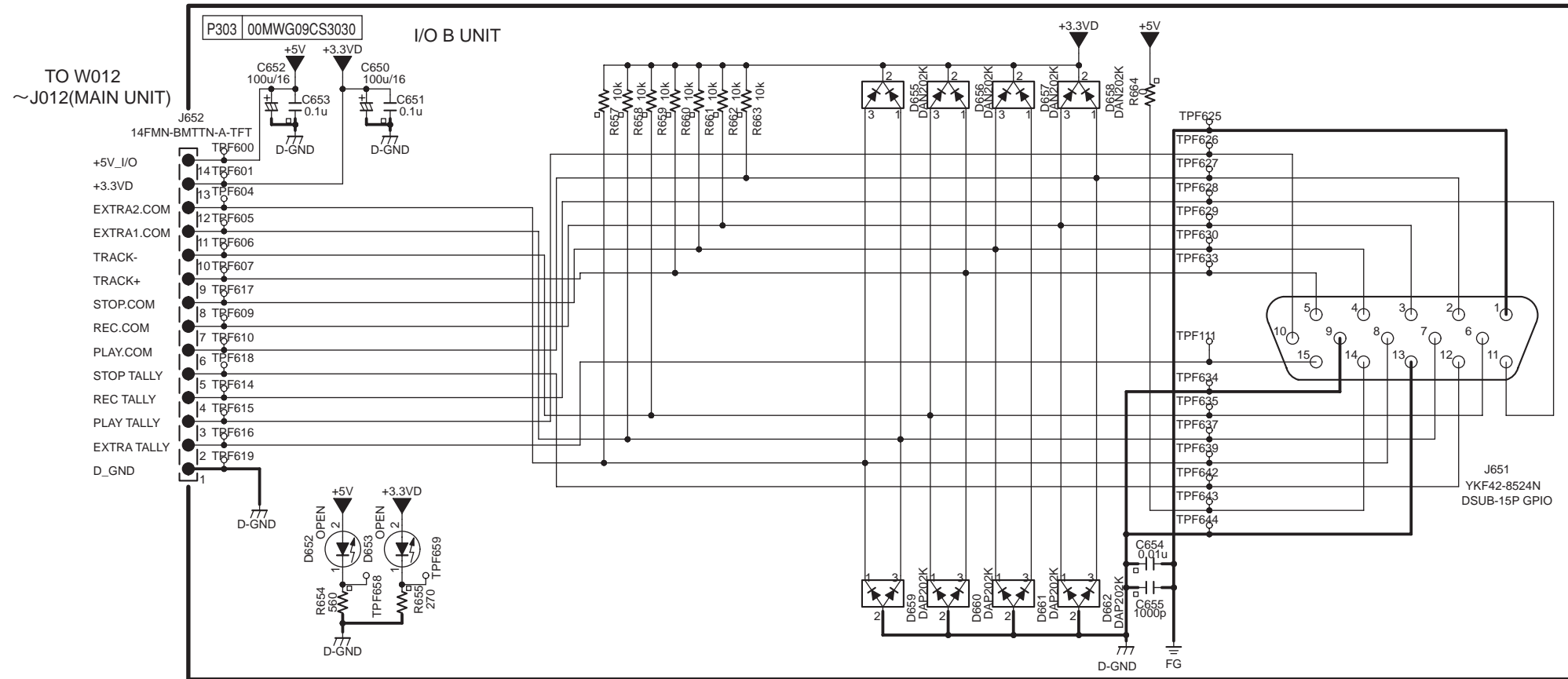
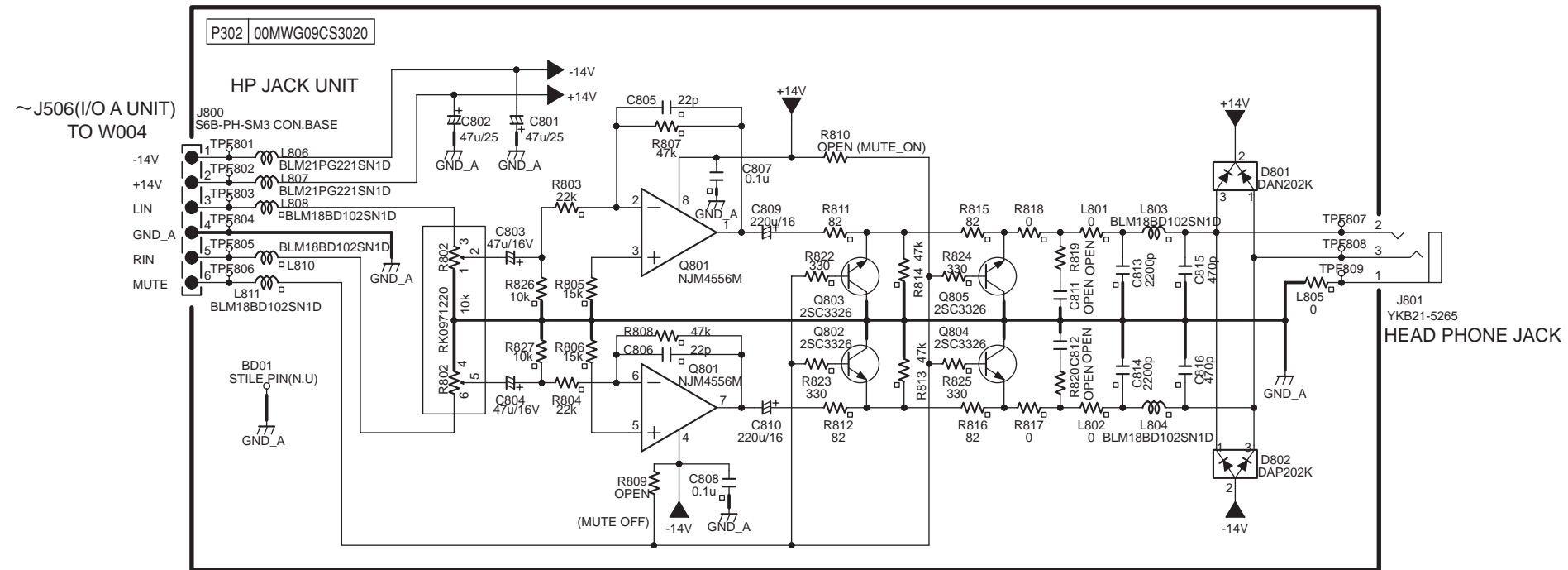

DSUB15P GPIO(Parallel Control) for J	
PIN No.	SIGNAL Name
1	FG
2	PLAY COMMAND
3	REC COMMAND
4	STOP COMMAND
5	TRACK(+) COMMAND
6	TRACK(-) COMMAND
7	EXTRA1 COMMAND
8	EXTRA2 COMMAND
9	COMMAND COMMON(GND)
10	PLAY TALLY
11	REC TALLY
12	STOP TALLY
13	TALLY COMMON(GND)
14	TALLY POWER SUPPLY(+5V)
15	EXTRA TALLY

# 8. PARTS LOCATION

B101	E10	D018	D4	R057	D8	R235	D3	R421	D8
C002	G6	D025	E2	R058	F2	R236	D5	R422	D3
C004	D3	D110	D9	R060	G9	R240	D3	R423	D4
C006	F6	D118	C3	R061	G9	R245	D3	R434	D2
C007	D2	J001	G5	R062	G9	R246	G1	R435	D2
C010	B5	J004	H8	R063	G3	R247	G1	R436	G1
C011	G6	J005	E1	R065	C6	R248	G1	R448	F2
C013	F7	J007	C10	R066	B6	R249	D9	R450	B7
C016	E7	J008	B2	R067	B6	R250	D9	R452	E2
C018	G4	J011	C8	R068	B6	R251	D9	R461	C2
C040	F9	J012	H3	R069	B6	R252	D9	R462	C2
C045	D9	J013	C1	R070	B6	R253	D9	R466	G8
C046	C5	J014	H9	R071	D8	R254	D9	R467	F8
C047	C5	J015	G7	R072	E9	R255	D9	R468	F8
C048	D4	J051	A5	R073	E8	R257	D10	R470	F9
C049	D4	J052	G3	R074	E8	R259	D9	R471	F9
C065	D4	L001	C9	R075	F8	R260	D2	R472	G3
C073	F2	L002	D9	R076	E9	R267	D5	R473	G3
C074	F1	L004	C9	R077	B6	R272	D6	R476	G3
C078	D9	L011	D3	R078	B6	R273	D6	R477	G3
C082	E2	L012	D5	R079	E7	R281	C5	R478	F2
C083	E2	L013	G3	R084	C9	R282	C5	R483	E2
C084	E2	L014	G8	R085	D9	R284	G7	R484	G2
C085	E2	L015	G8	R087	F8	R285	G7	R485	C8
C086	D2	L016	G8	R088	F1	R286	G8	R486	C8
C087	C10	L017	C8	R096	D5	R287	G8	R487	C8
C088	D4	L018	C8	R125	F1	R288	C1	R488	C8
C091	D3	L019	C8	R132	D4	R289	B1	R489	D8
C100	D5	L112	C8	R133	F3	R290	G1	R490	D2
C123	D3	L113	D8	R134	F3	R291	G1	R491	D2
C125	E2	L120	G8	R135	F4	R292	C5	R494	D2
C126	A5	L151	A5	R136	F4	R293	C6	R496	F9
C128	C2	L152	A5	R137	F4	R294	G6	R497	D8
C151	C7	L650	G8	R138	F4	R295	G6	R498	D8
C152	D5	Q005	E6	R139	F4	R296	B10	R499	F2
C153	D2	Q007	F6	R140	F4	R297	B10	RU02	A4
C154	B6	Q009	E3	R153	F5	R298	C4	RU08	B4
C155	G2	Q010	F2	R154	F4	R299	C4	RU09	A4
C157	F7	Q015	F1	R155	F4	R300	C4	RU10	A4
C158	F8	Q018	E4	R156	F5	R301	C2	RU11	A5
C159	E7	Q022	C6	R157	F5	R302	C2	RU12	A5
C161	F7	Q024	F2	R158	F5	R303	E7	RU14	F10
C165	B8	Q026	D2	R159	F5	R318	E8	RU15	G9
C168	G4	Q029	E2	R160	F5	R319	E8	RU21	G10
C169	G8	Q036	D8	R161	F4	R320	E8	RU22	G10
C173	G9	Q037	C7	R162	F4	R321	E8	RU23	G10
C174	G8	Q038	B7	R163	F5	R322	E7	RU24	G9
C175	B7	Q039	F2	R164	F4	R323	E7	RU25	G9
C176	F2	Q040	G2	R165	F4	R324	E8	RU26	G9
C177	D6	Q042	F8	R166	F4	R325	E8	RU27	G9
C178	D8	Q043	E2	R167	D3	R327	E7	RU28	G8
C179	E5	Q105	D5	R168	F4	R330	E8	RU33	A4
C182	F7	Q111	B5	R169	D3	R337	F7	RU34	D9
C195	E2	Q112	D8	R170	E5	R338	F7	RU35	G9
C196	G4	Q117	C4	R173	F5	R339	F7	RU36	G9
C197	E2	Q118	C5	R182	D6	R340	F8	RU37	F9
C199	F8	Q119	C4	R183	D6	R341	F8	RU38	G3
C402	D8	Q120	G10	R184	D6	R343	D8	RU39	A4
C403	F1	Q121	G9	R185	D6	R344	E7	RU40	A4
C408	C4	Q126	A4	R186	D6	R345	E6	RU42	C5
C409	C4	Q156	A4	R187	D6	R346	F7	RU44	C5
C410	F2	Q157	A5	R188	D6	R347	F8	RU47	C5
C420	C8	Q159	C2	R189	C6	R352	C2	RU49	C5
C422	G3	Q300	G4	R190	C5	R354	C2	RU52	C5
C424	D7	Q401	E8	R191	D5	R360	C2	RU54	C5
C426	E2	Q402	E2	R192	D5	R362	C2	RU55	E6
C427	D9	Q403	G4	R193	D5	R364	C2	RU56	C4
C428	D9	Q404	E2	R194	D5	R366	C2	RU57	E3
C429	D9	Q406	F8	R195	D5	R371	C3	RU58	A4
C430	D9	RU11	D3	R196	D5	R372	C2	RU88	C5
C431	D9	RU16	D9	R197	D5	R374	C2	RU89	C5
C432	D9	RU20	D2	R198	D7	R375	C3	RU91	F3
C433	D9	RU21	D2	R199	D7	R376	C3	RU92	F3
C436	C1	RU22	E7	R200	D7	R381	C3	RU93	F3
C437	G3	RU23	E6	R201	D7	R382	F5	RU94	F3
C438	E2	RU25	E6	R202	D7	R383	F5	RU95	F3
CU31	C4	RU26	D5	R203	D7	R385	E5	RU96	F3
CU33	B4	RU27	E6	R204	D7	R386	E5	RU97	F3
CU34	B4	RU28	E6	R205	C7	R394	D2	RU98	F3
CU37	C4	RU30	D7	R206	C7	R397	E2	RU99	F4
CU46	A4	RU31	D7	R207	D7	R398	G7	RV01	F4
CU47	A5	RU33	G6	R208	D7	R399	G8	RV21	C2
CU48	C4	RU34	D3	R209	D7	R400	C3	RV22	C2
CU49	C3	RU35	C2	R210	D7	R401	C3	RV25	C3
CU53	C4	RU37	F6	R211	D7	R404	C5	RV26	C4
D001	G6	RU38	F6	R212	D7	R405	C5	RV27	C3
D002	C2	RU40	E6	R213	D7	R406	C3	RV29	C4
D003	D1	RU41	D1	R215	F2	R407	C3	RV30	C4
D004	F6	RU42	E6	R217	F5	R410	D4	RV31	C4
D006	D7	RU43	E6	R218	F5	R411	D4	S001	D7
D007	E9	RU44	D7	R225	C2	R414	D8	S002	G1
D008	E9	RU45	E6	R227	E2	R415	D8	X001	D4
D009	E9	RU46	E6	R228	F2	R416	C8	X002	C5
D013	D3	RU47	E9	R229	E6	R417	C8	X004	F8
D014	D3	RU50	B6	R230	D5	R418	C8	X103	B4
D016	C9	RU51	C6	R232	D5	R419	C8		
D017	D10	RU56	D8	R234	D3	R420	D3		

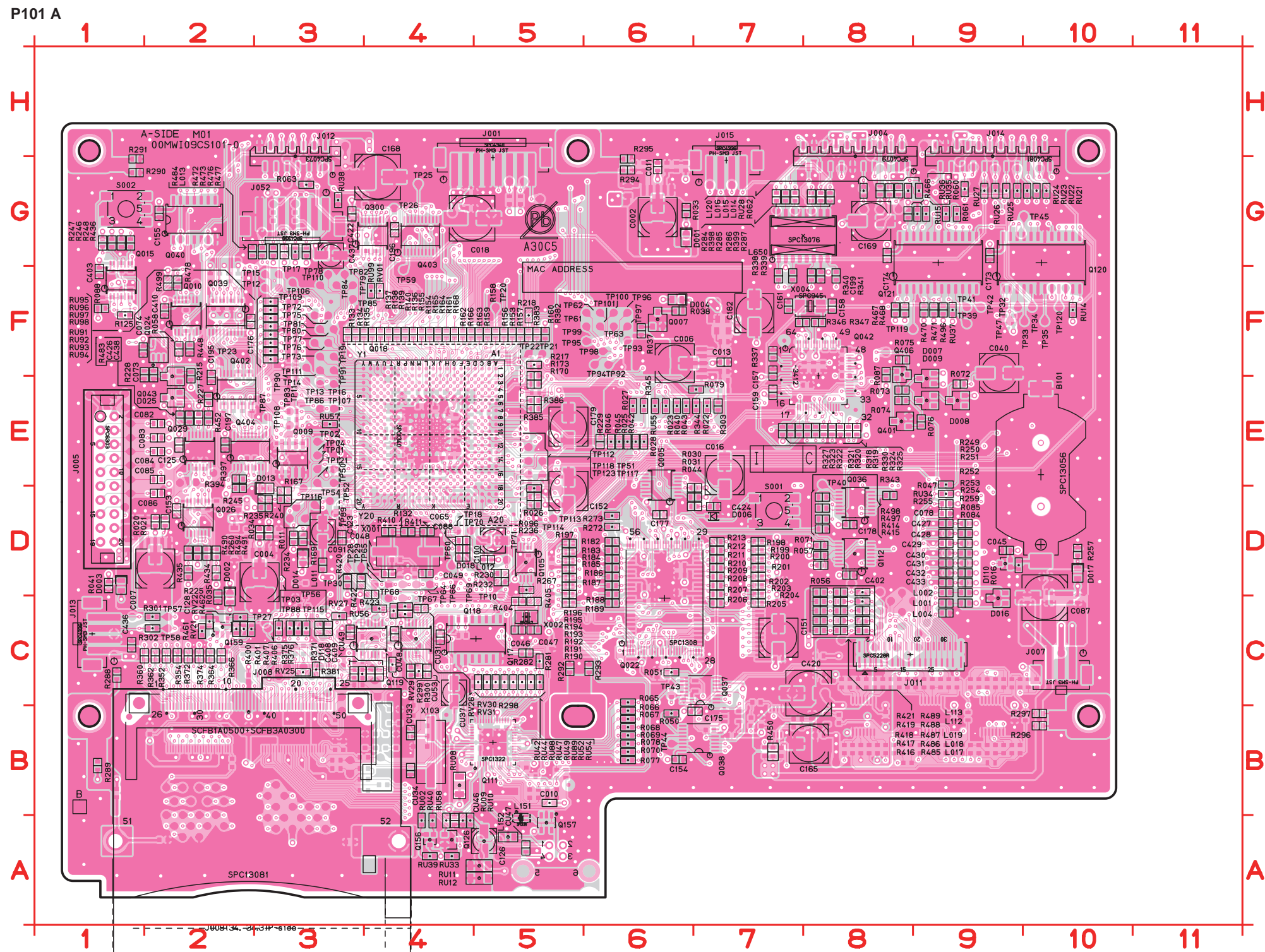



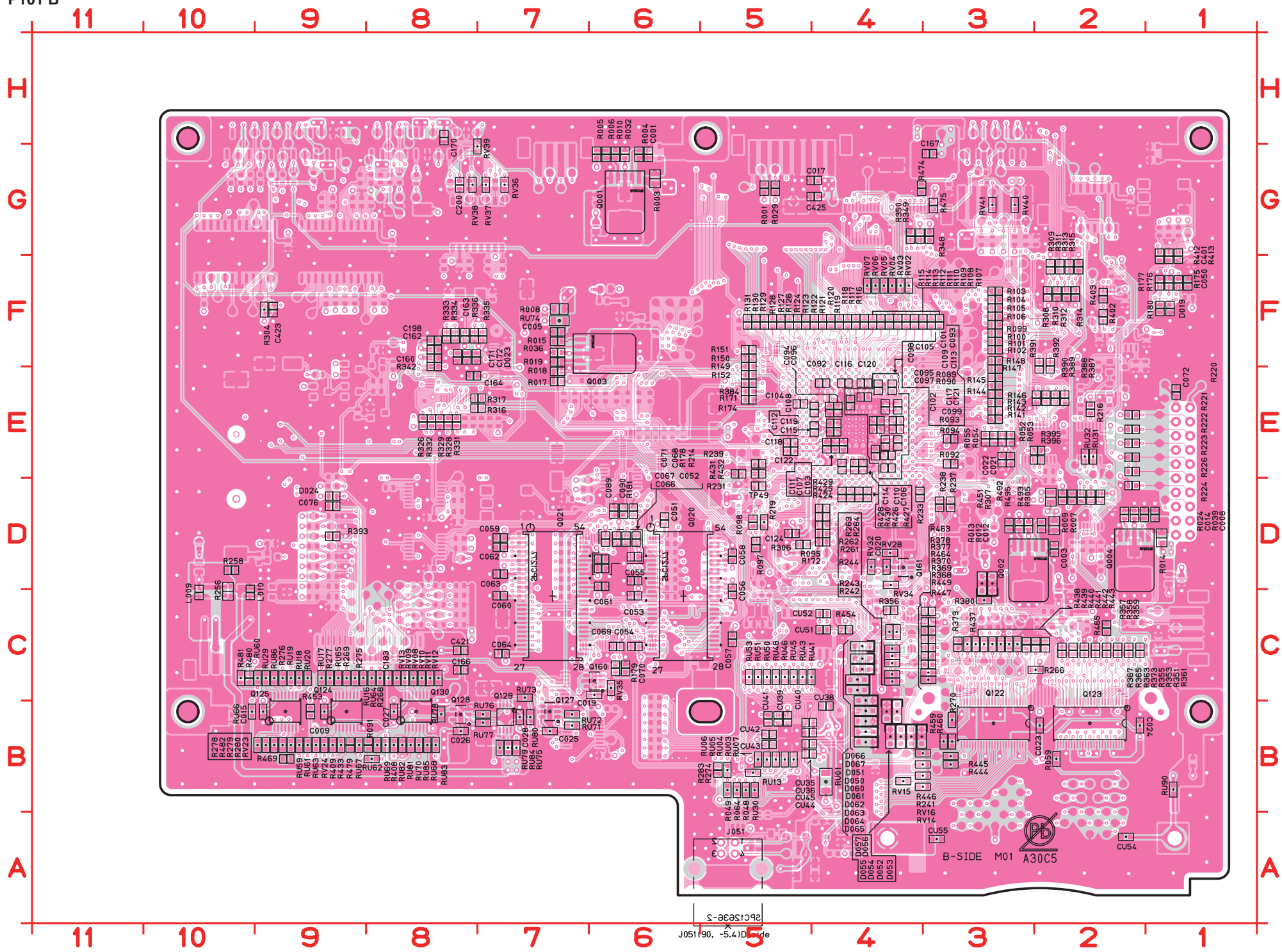

C001	G6	CU35	B5	R099	F3	R305	D2	R469	B9
C003	D2	CU36	B5	R100	F3	R306	D5	R474	G4
C005	F7	CU38	B4	R101	F3	R307	D2	R475	G3
C008	D1	CU39	B5	R102	F3	R308	F2	R479	B9
C009	B9	CU40	B5	R103	F3	R309	F2	R480	C10
C012	D3	CU41	B5	R104	F3	R310	F2	R481	C10
C014	D2	CU42	B5	R105	F3	R311	F2	R482	B9
C015	B9	CU43	B5	R106	F3	R312	F2	R492	D2
C017	G4	CU44	B5	R107	F3	R313	F2	R493	D2
C019	C6	CU45	B5	R108	F3	R314	F2	R495	D2
C020	D4	CU51	C4	R109	F4	R315	F2	RU01	B4
C021	E3	CU52	C4	R110	F4	R316	E7	RU03	B5
C022	E3	CU54	A2	R111	F4	R317	E7	RU04	B5
C023	B2	CU55	A3	R112	F4	R326	E8	RU05	B5
C024	B2	D019	F1	R113	F4	R328	E8	RU06	B5
C025	B7	D023	F8	R114	F4	R329	E8	RU07	B5
C026	B8	D024	D9	R115	F4	R331	E8	RU13	B5
C027	B8	D050	C4	R116	F4	R332	E8	RU16	C9
C028	B7	D051	C4	R117	F4	R333	F8	RU17	C9
C050	F1	D052	B4	R118	F4	R334	F8	RU18	C9
C051	D6	D053	B4	R119	F4	R335	F7	RU19	C9
C052	D6	D054	B4	R120	F4	R336	F8	RU20	C9
C053	C6	D055	B4	R121	F4	R342	F8	RU29	C9
C054	C6	D056	B4	R122	F4	R348	G3	RU30	B5
C055	D6	D057	B4	R123	F5	R349	G4	RU31	E2
C056	C5	D058	D3	R124	F5	R350	G4	RU32	E2
C057	C5	D059	D3	R126	F5	R351	C2	RU41	C5
C058	D5	D060	C4	R127	F5	R353	C2	RU43	C5
C059	D7	D061	C4	R128	F5	R355	C2	RU45	C5
C060	C7	D062	B4	R129	F5	R356	C4	RU46	C5
C061	D6	D063	B4	R130	F5	R357	C3	RU48	C5
C062	D7	D064	B4	R131	F5	R358	C2	RU50	C5
C063	D7	D065	B4	R141	E3	R359	C2	RU51	C5
C064	C7	D066	C4	R142	E3	R361	C2	RU53	C5
C066	D6	D067	C4	R143	E3	R363	C2	RU59	B9
C067	D6	L009	C10	R144	E3	R365	C2	RU60	C9
C068	D6	L010	C10	R145	E3	R367	C2	RU61	B9
C069	C6	Q001	G6	R146	E3	R368	C3	RU62	B8
C070	C6	Q002	D3	R147	E3	R369	C3	RU63	B9
C071	D6	Q003	F6	R148	F3	R370	C3	RU64	C8
C072	E1	Q004	D2	R149	F5	R373	C2	RU65	C9
C076	D9	Q020	C6	R150	F5	R377	C3	RU66	B10
C089	D6	Q021	C7	R151	F5	R378	C3	RU67	B9
C090	D6	Q122	B3	R152	E5	R379	C3	RU68	B8
C092	E4	Q123	B2	R171	E5	R380	C3	RU69	B8
C093	E4	Q124	B9	R172	D4	R384	E5	RU70	B8
C094	E4	Q125	B9	R174	E5	R387	E2	RU71	B7
C095	E4	Q127	B7	R175	F1	R388	E2	RU72	B7
C096	E4	Q128	B8	R176	F1	R389	E2	RU73	C7
C097	E4	Q129	B7	R177	F1	R390	E2	RU74	F7
C098	E4	Q130	B8	R178	D6	R391	F2	RU75	B7
C099	E4	Q160	C6	R179	C6	R392	F2	RU76	B7
C101	E4	Q161	D4	R180	F1	R393	D9	RU77	B7
C102	E4	R001	G5	R181	D6	R395	E2	RU78	B8
C103	E4	R003	G6	R214	D6	R396	E2	RU79	B7
C104	E5	R004	G6	R216	E2	R402	F2	RU80	B7
C105	E4	R005	G6	R219	D5	R403	F2	RU81	B8
C106	E4	R006	G6	R220	E2	R408	B8	RU82	B8
C107	E4	R007	D2	R221	E2	R409	B9	RU83	B8
C108	E4	R008	F7	R222	E2	R412	F1	RU84	B7
C109	E4	R009	D2	R223	E2	R413	F1	RU85	B8
C110	E4	R010	G6	R224	D2	R424	D4	RU86	C9
C111	E4	R012	D3	R226	E2	R425	D4	RU90	B1
C112	E4	R013	D3	R231	D5	R426	D4	RV02	F4
C113	E4	R014	D1	R233	D4	R427	D4	RV03	F4
C114	E4	R015	F7	R237	D3	R428	D4	RV04	F4
C115	E4	R017	E7	R238	D3	R429	D4	RV05	F4
C116	E4	R018	E7	R239	E5	R430	D4	RV06	F4
C117	E4	R019	F7	R241	B4	R431	E5	RV07	F4
C118	E5	R024	D2	R242	C4	R432	E5	RV08	C8
C119	E4	R029	G5	R243	C4	R433	B9	RV09	C8
C120	E4	R032	G6	R244	C4	R437	C3	RV10	C8
C121	E4	R036	F7	R256	C10	R438	C3	RV11	C8
C122	E5	R039	D2	R258	D10	R439	C3	RV12	C8
C124	D5	R048	B5	R261	C4	R440	C3	RV13	C8
C160	F8	R049	B5	R262	C4	R441	C3	RV14	B4
C162	F8	R052	E3	R263	C4	R442	C3	RV15	B4
C163	F8	R053	E3	R264	C4	R443	C3	RV16	B4
C164	E8	R054	E3	R266	C2	R444	B3	RV23	B9
C166	C8	R055	E3	R268	C8	R445	B3	RV24	B9
C167	G3	R059	B2	R269	C9	R446	B4	RV28	D4
C170	H8	R064	B5	R270	B3	R447	C3	RV32	D4
C171	F8	R089	E4	R274	B5	R449	C3	RV34	D4
C172	F8	R090	E4	R275	C9	R451	D2	RV35	C6
C183	C8	R091	B8	R276	C9	R453	B9	RV36	G7
C198	F8	R092	E3	R277	C9	R454	C4	RV37	G7
C200	G8	R093	E4	R278	B9	R459	B3	RV38	G8
C401	F1	R094	E3	R279	B9	R460	B3	RV39	G8
C421	C8	R095	D4	R280	B9	R463	C3	RV40	G3
C423	F9	R097	D5	R283	B5	R464	C3	RV41	G3
C425	G4	R098	D5	R304	F9	R465	C2		

**鉛フリー半田**  
 半田付けには、鉛フリー半田 (Sn-Ag-Cu) を使用してください。  
**Lead-free Solder**  
 When soldering, use the Lead-free Solder (Sn-Ag-Cu).



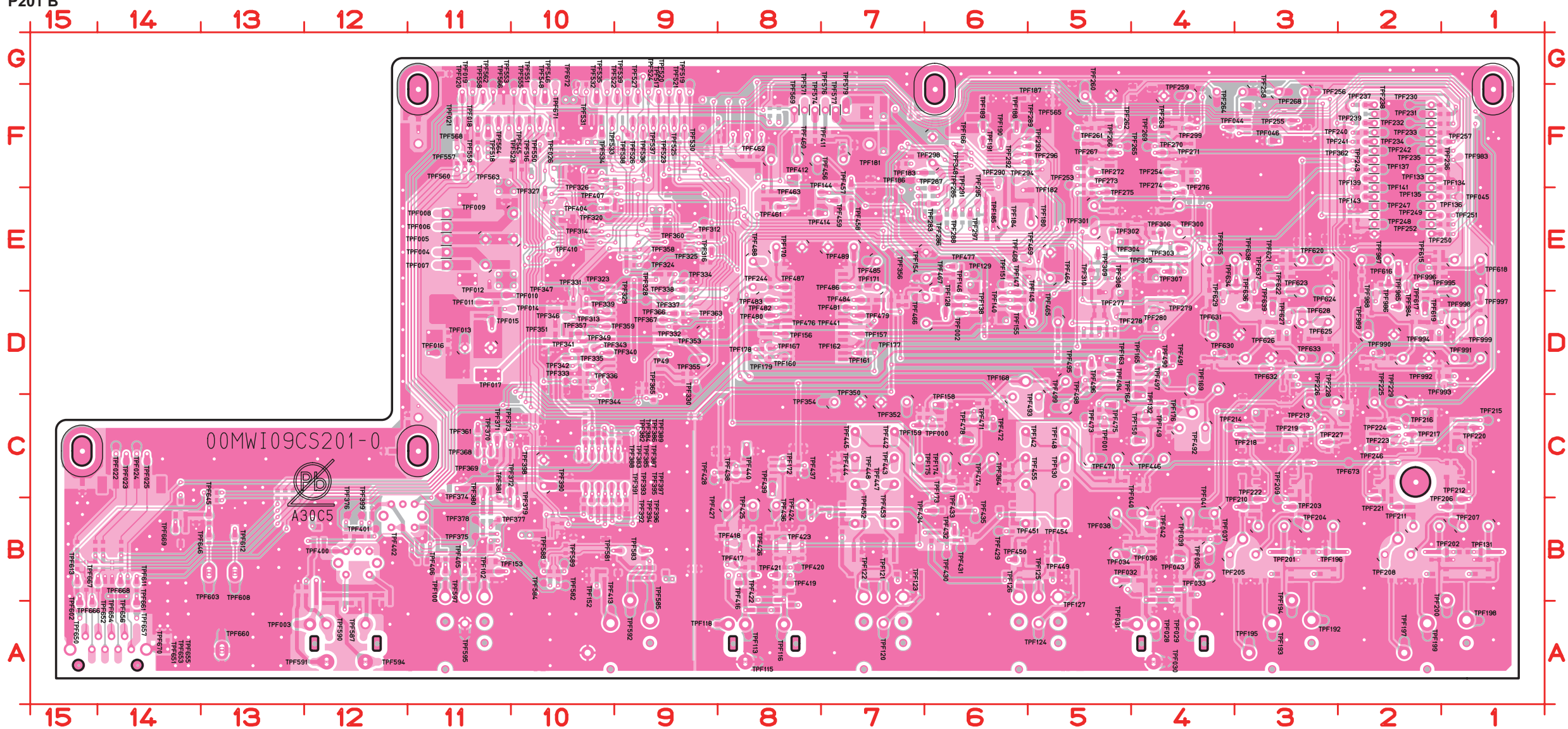

**鉛フリー半田**  
 半田付けには、鉛フリー半田 (Sn-Ag-Cu) を使用してください。

**Lead-free Solder**  
 When soldering, use the Lead-free Solder (Sn-Ag-Cu).

P202 A

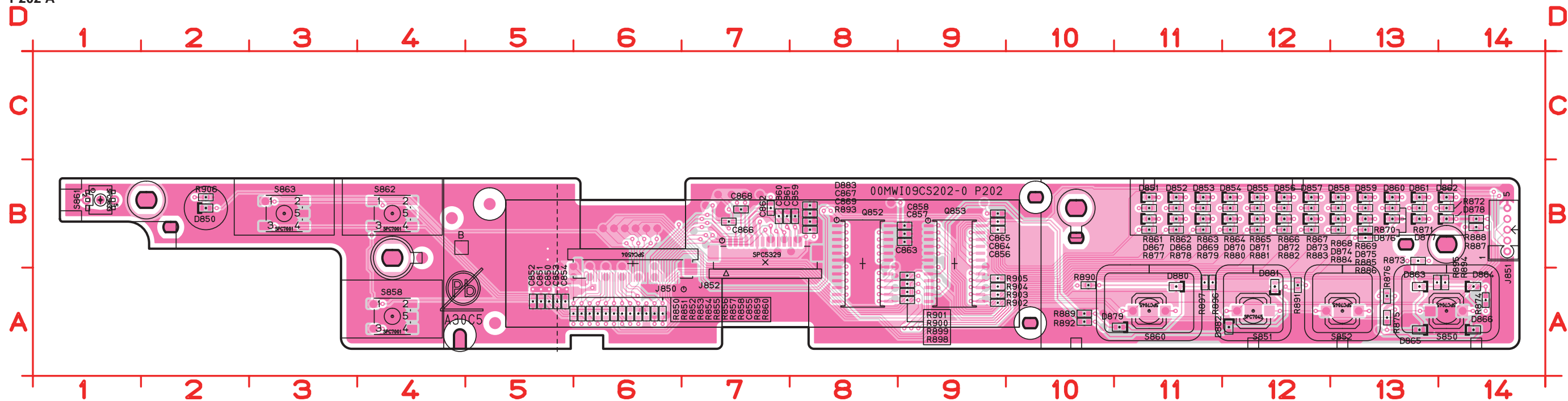

P202 B

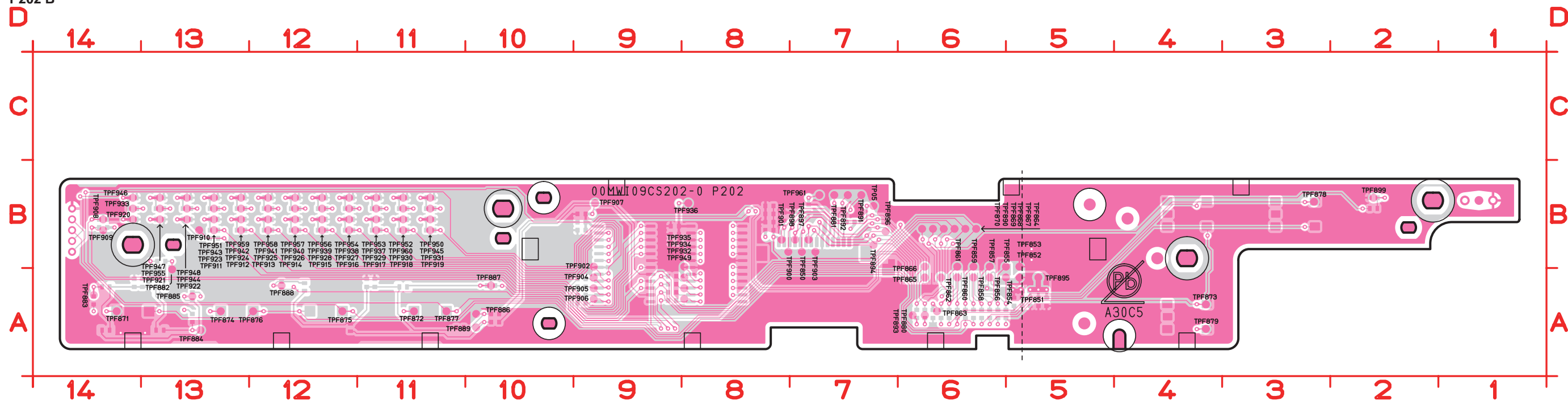

C850 A5	C866 B7	D862 B14	D878 B14	R855 A6	R871 B13	R887 B14	R903 A9
C851 A5	C867 B8	D863 A13	D879 A11	R856 A6	R872 B14	R888 B14	R904 A9
C852 A5	C868 B7	D864 A14	D880 A11	R857 A6	R873 B13	R889 A10	R905 A9
C853 A5	C869 B8	D865 A13	D881 A12	R858 A6	R874 A14	R890 A10	R906 B2
C854 A5	D850 B2	D866 A14	D882 A12	R859 A6	R875 A13	R891 A12	S850 A14
C855 A6	D851 B11	D867 B11	D883 B8	R860 A6	R876 A13	R892 A10	S851 A12
C856 B9	D852 B11	D868 B11	J850 B6	R861 B11	R877 B11	R893 B8	S852 A13
C857 B9	D853 B11	D869 B11	J851 B14	R862 B11	R878 B11	R894 A14	S858 A4
C858 B9	D854 B12	D870 B12	J852 B7	R863 B11	R879 B11	R895 A13	S860 A11
C859 B8	D855 B12	D871 B12	Q852 B8	R864 B12	R880 B12	R896 A11	S861 B1
C860 B7	D856 B12	D872 B12	Q853 B9	R865 B12	R881 B12	R897 A11	S862 B4
C861 B7	D857 B12	D873 B12	R850 A6	R866 B12	R882 B12	R898 A9	S863 B3
C862 B7	D858 B13	D874 B13	R851 A6	R867 B12	R883 B12	R899 A9	
C863 B9	D859 B13	D875 B13	R852 A6	R868 B13	R884 B13	R900 A9	
C864 B9	D860 B13	D876 B13	R853 A6	R869 B13	R885 B13	R901 A9	
C865 B9	D861 B13	D877 B13	R854 A6	R870 B13	R886 B13	R902 A9	

**鉛フリー半田**  
 半田付けには、鉛フリー半田 (Sn-Ag-Cu) を使用してください。  
**Lead-free Solder**  
 When soldering, use the Lead-free Solder (Sn-Ag-Cu).

P203 A

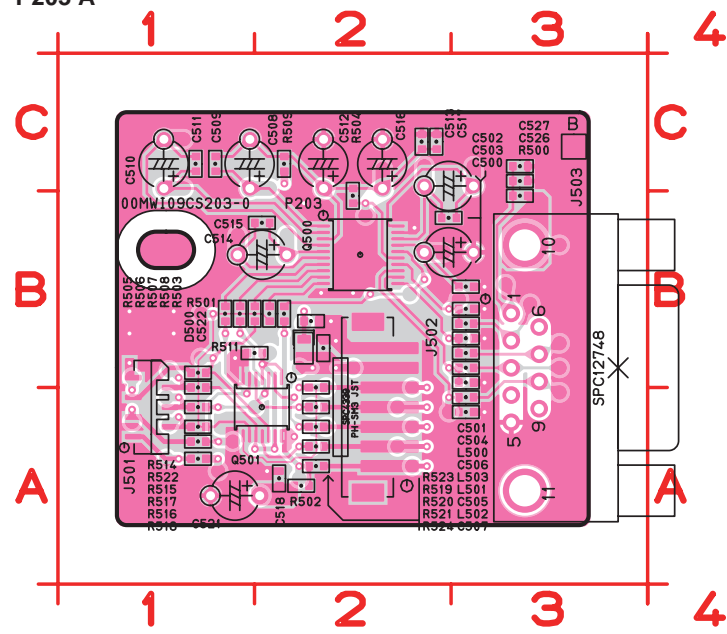

P203 B

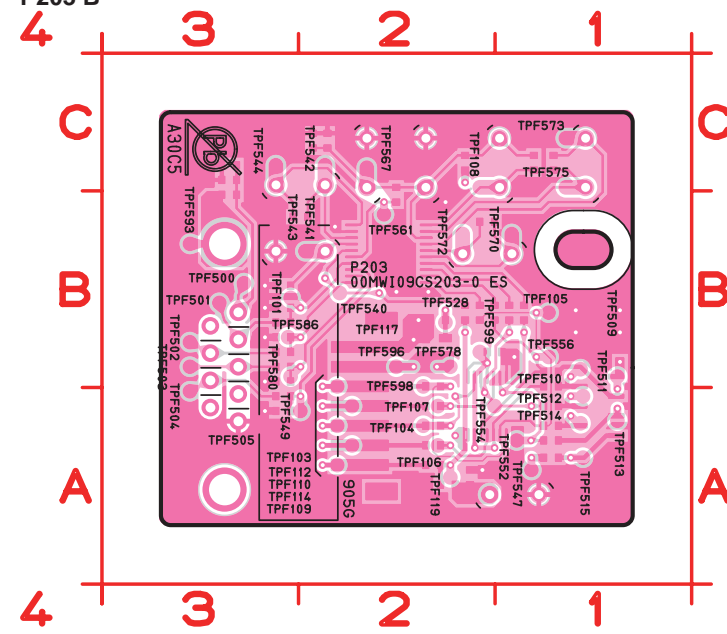

C500 B3	C511 C1	C527 C3	R500 B3	R514 B1
C501 B3	C512 C2	D500 B2	R501 B2	R515 A1
C502 C3	C513 C2	J501 A1	R502 A2	R516 A1
C503 B2	C514 B2	J502 A2	R503 B2	R517 A1
C504 B3	C515 B2	J503 B3	R504 B2	R518 A1
C505 B3	C516 C2	L500 B3	R505 B1	R519 A2
C506 B3	C517 C2	L501 B3	R506 B1	R520 A2
C507 A3	C518 A2	L502 A3	R507 B2	R521 A2
C508 C1	C521 A2	L503 B3	R508 B2	R522 B1
C509 C1	C522 B2	Q500 B2	R509 C2	R523 B2
C510 C1	C526 C3	Q501 A2	R511 B2	R524 A2

P204 A

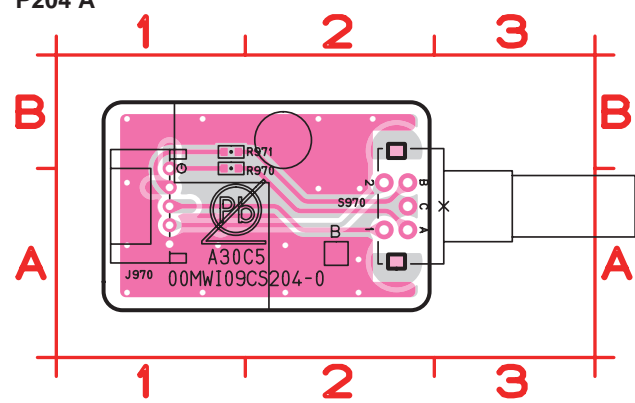

P204 B

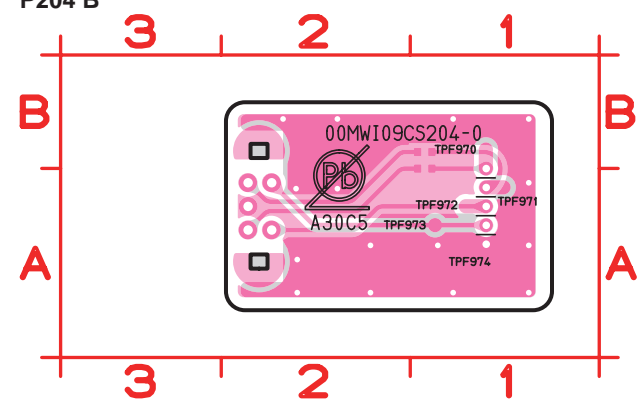

J970 B1
R970 B1
R971 B1
S970 A3

P205 A

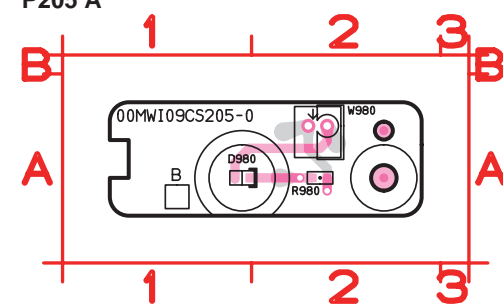

P205 B

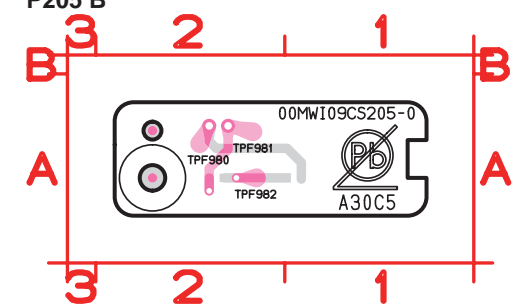

D980 A1
R980 A2
W980 A2

**鉛フリー半田**  
半田付けには、鉛フリー半田 (Sn-Ag-Cu) を使用してください。

**Lead-free Solder**  
When soldering, use the Lead-free Solder (Sn-Ag-Cu).

BD02	F6	D720	A2	R736	C9
BD03	D6	G700	C1	R737	C9
BD06	B6	J701	B1	R738	C9
BD07	D6	J702	A8	R739	B10
C700	C2	J703	A4	R740	A3
C701	D1	J704	F6	R741	C10
C702	E1	J705	F1	R742	B10
C703	G1	J707	A10	R743	B10
C704	F3	J708	C3	R744	C10
C705	E4	J709	D3	R745	C6
C706	D4	J710	E10	R746	C6
C707	D5	J711	F10	R747	D7
C708	D4	L700	E2	R748	D7
C709	D4	L701	A5	R751	D7
C710	F5	L702	B5	R752	E7
C711	E6	L703	C7	R753	D7
C712	F6	L704	B9	R754	D7
C713	B4	L705	D8	R755	D7
C714	B4	L706	D9	R756	C6
C715	B5	L707	F8	R757	D7
C716	F10	L708	F9	R758	A6
C717	B7	Q700	D5	R759	A6
C718	B7	Q701	F5	R760	A6
C719	B7	Q702	E6	R761	E7
C720	F7	Q703	F7	R762	E7
C721	F7	Q704	C9	R763	D7
C722	F8	Q705	B10	R764	E7
C723	F8	Q706	C10	R765	E7
C724	C8	Q707	C6	R766	F7
C725	C9	Q708	C8	R767	F6
C726	C9	Q709	D7	R768	F6
C727	C9	Q710	A6	R769	F6
C728	B9	Q711	A6	R770	F7
C729	D7	Q712	F6	R771	F7
C730	D7	Q713	F7	R772	F6
C731	D7	Q714	E7	R773	E6
C732	F7	Q715	E9	R774	E8
C733	E8	Q716	D8	R775	E8
C734	E9	Q717	E8	R776	E9
C735	E9	Q718	D8	R777	E9
C736	E9	Q719	B6	R778	E9
C737	E9	Q720	B10	R779	E9
C738	E9	R700	D1	R780	E9
C739	E9	R701	D4	R781	E8
C740	E8	R702	D4	R782	E9
C741	D9	R703	D5	R783	E8
C742	D9	R704	E6	R784	E9
C743	D9	R705	E6	R785	E9
C744	D9	R706	E6	R786	D8
C745	F8	R707	E6	R787	D8
C746	F9	R708	E6	R788	D9
C747	B7	R709	E6	R789	D9
C749	E9	R710	E6	R790	D9
C750	E9	R711	B4	R791	D10
C751	E9	R712	B6	R792	E8
C752	D9	R713	A5	R793	E8
C753	E9	R714	B10	R794	E9
C754	A3	R715	B10	R795	E9
C755	F2	R716	B10	R796	F10
D700	G3	R717	C7	R797	F8
D701	E3	R718	B7	R798	D7
D702	B4	R719	B7	R799	B10
D703	D4	R720	B7	R829	D9
D705	E6	R721	C8	R830	E9
D706	B5	R722	B8	R831	B6
D708	B7	R723	B8	R832	B10
D709	C7	R724	B10	R991	D8
D710	B9	R726	B8	R992	D8
D711	B10	R727	C7	R993	D5
D712	C9	R728	F7	R994	E6
D713	C10	R729	F8	R995	E6
D714	F7	R730	F8	S700	B2
D715	D8	R731	F8	S701	B6
D716	D10	R732	F8	S702	C6
D717	F8	R733	C9	T700	D5
D718	E10	R734	C9	X700	D8
D719	F8	R735	C9		

P301 A

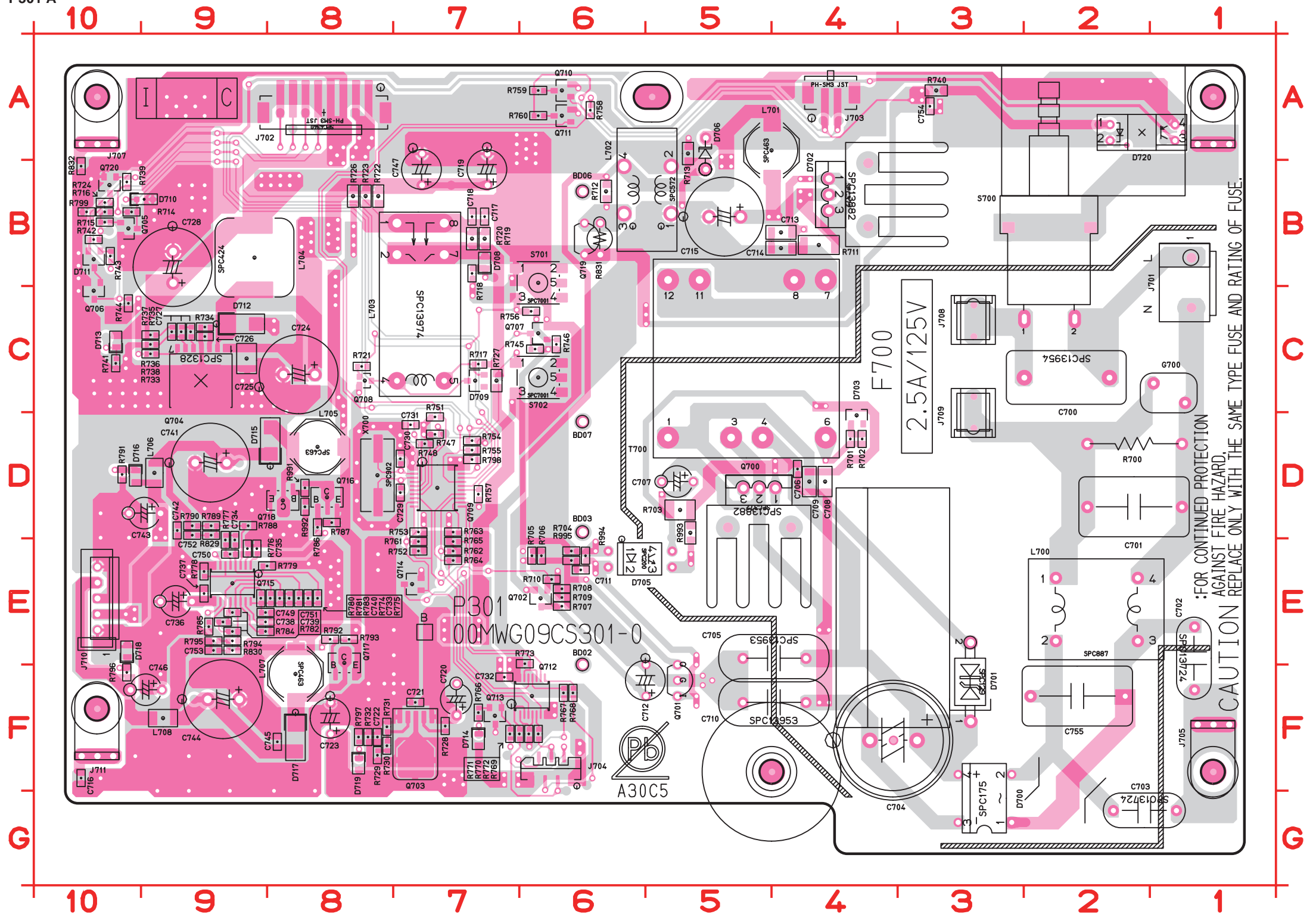

**鉛フリー半田**

半田付けには、鉛フリー半田 (Sn-Ag-Cu) を使用してください。

**Lead-free Solder**

When soldering, use the Lead-free Solder (Sn-Ag-Cu).

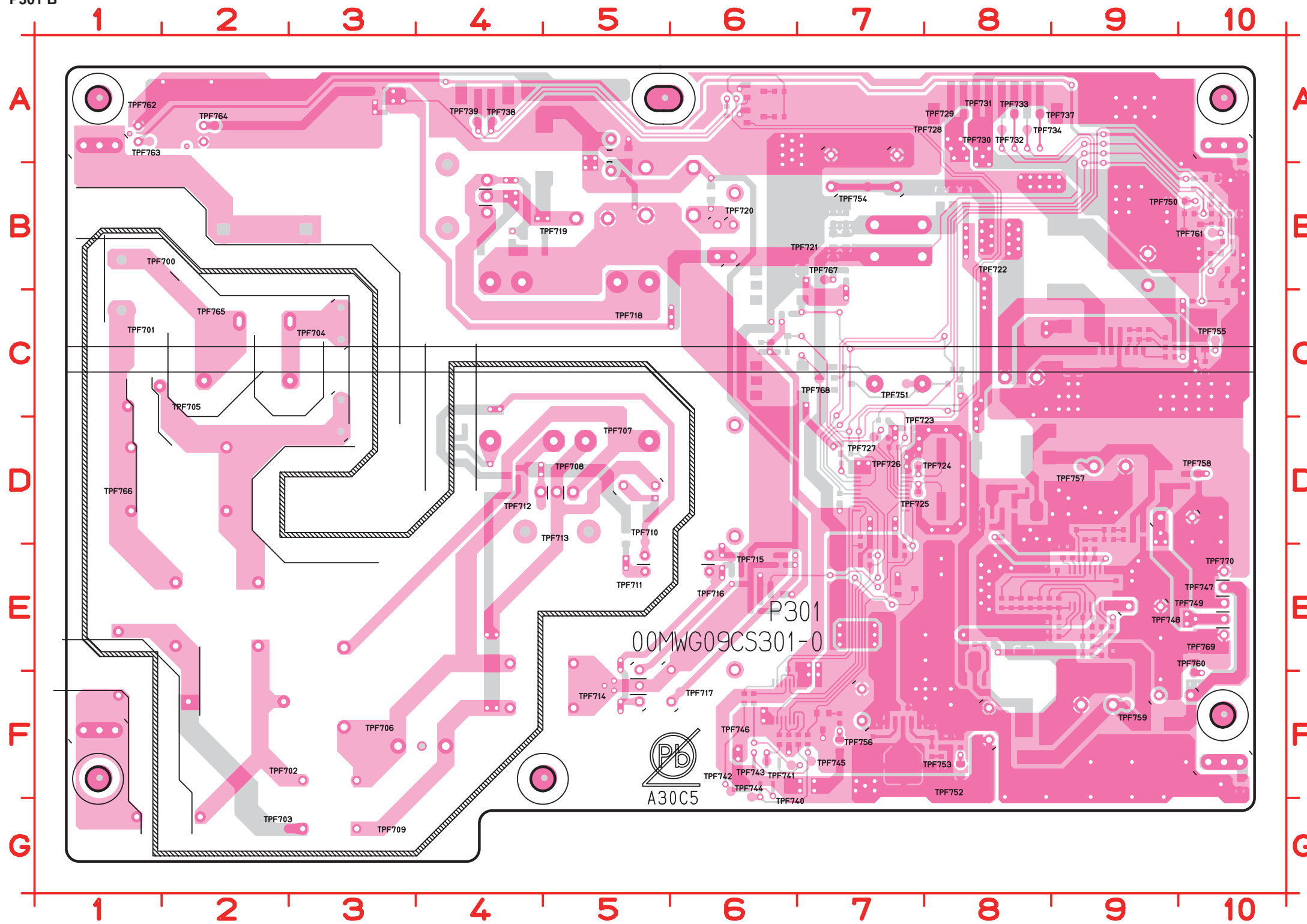

**鉛フリー半田**  
 半田付けには、鉛フリー半田 (Sn-Ag-Cu) を使用してください。

**Lead-free Solder**  
 When soldering, use the Lead-free Solder (Sn-Ag-Cu).

P302 A

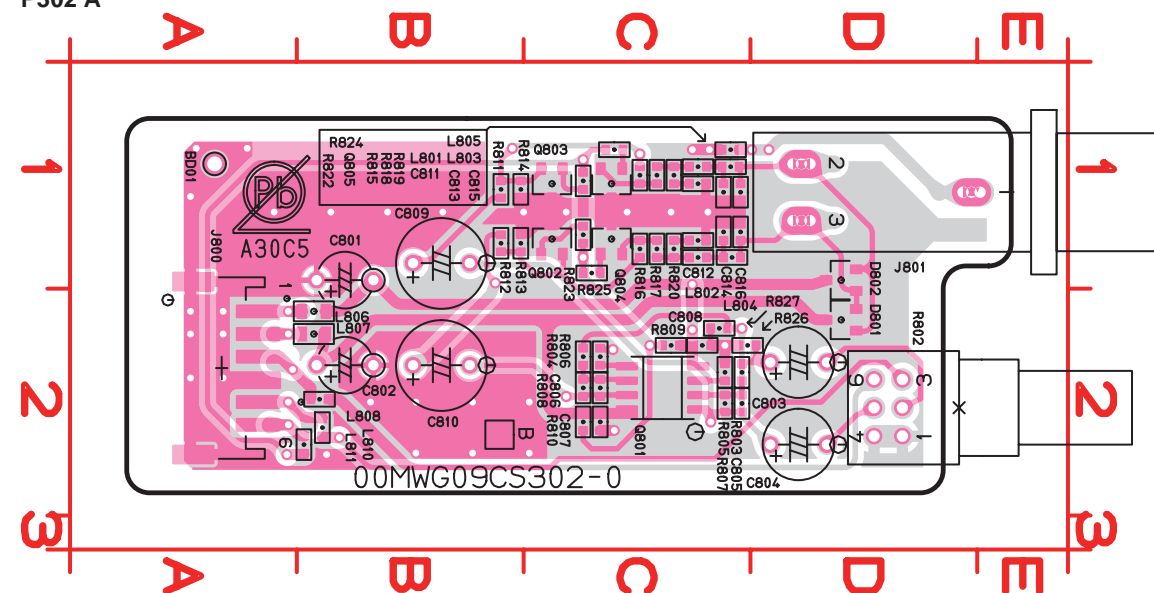

P302 B

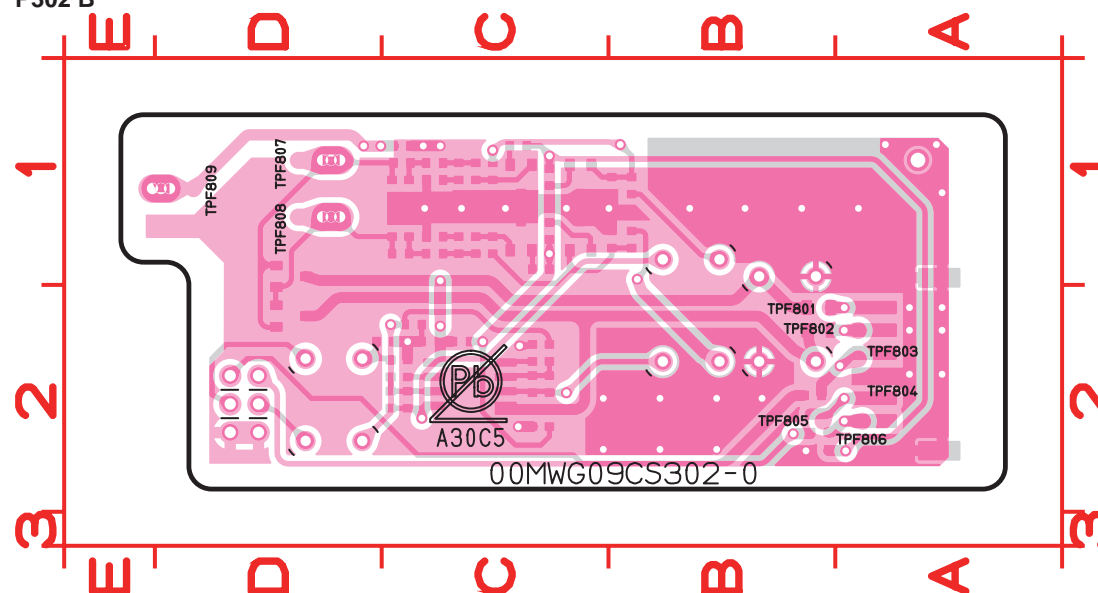

BD01	A1	C813	C1	L806	B2	R805	C2	R818	C1
C801	B1	C814	C1	L807	B2	R806	C2	R819	C1
C802	B2	C815	C1	L808	B2	R807	C2	R820	C1
C803	D2	C816	C1	L810	B2	R808	C2	R822	C1
C804	D2	D801	D2	L811	B2	R809	C2	R823	C1
C805	C2	D802	D1	Q801	C2	R810	C2	R824	C1
C806	C2	J800	A2	Q802	C1	R811	B1	R825	C1
C807	C2	J801	E1	Q803	C1	R812	B1	R826	C2
C808	C2	L801	C1	Q804	C1	R813	B1	R827	C2
C809	B1	L802	C1	Q805	C1	R814	B1		
C810	B2	L803	C1	R802	D2	R815	C1		
C811	C1	L804	C1	R803	C2	R816	C1		
C812	C1	L805	C1	R804	C2	R817	C1		

**鉛フリー半田**

半田付けには、鉛フリー半田 (Sn-Ag-Cu) を使用してください。

**Lead-free Solder**

When soldering, use the Lead-free Solder (Sn-Ag-Cu).



- |      |    |      |    |
|------|----|------|----|
| C650 | A1 | D662 | B2 |
| C651 | A1 | J651 | B3 |
| C652 | A2 | J652 | A1 |
| C653 | A2 | R654 | A2 |
| C654 | B2 | R655 | A2 |
| C655 | B2 | R657 | A1 |
| D652 | A2 | R658 | A2 |
| D653 | A2 | R659 | A2 |
| D655 | A2 | R660 | A1 |
| D656 | A2 | R661 | A1 |
| D657 | A2 | R662 | A1 |
| D658 | A2 | R663 | A2 |
| D659 | B2 | R664 | A2 |
| D660 | B2 |      |    |
| D661 | B2 |      |    |

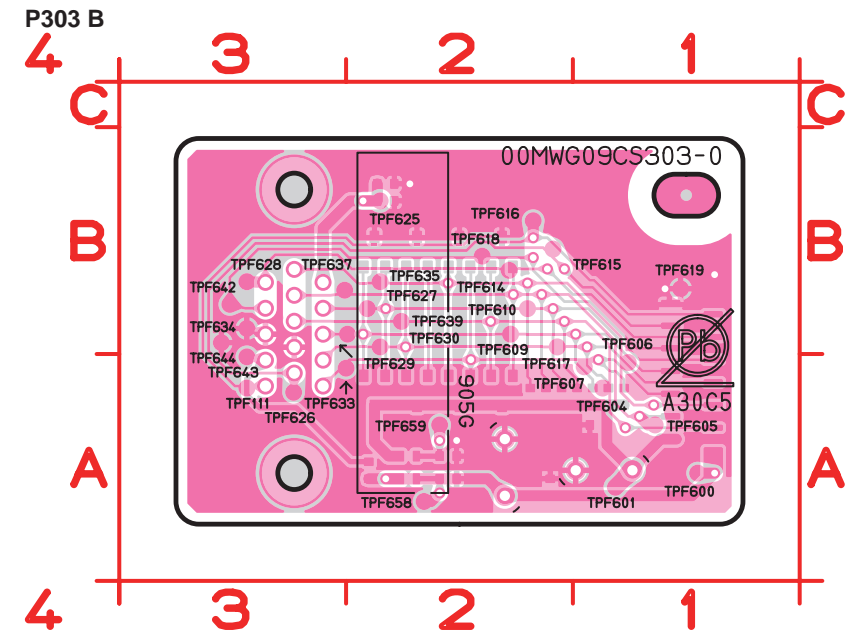
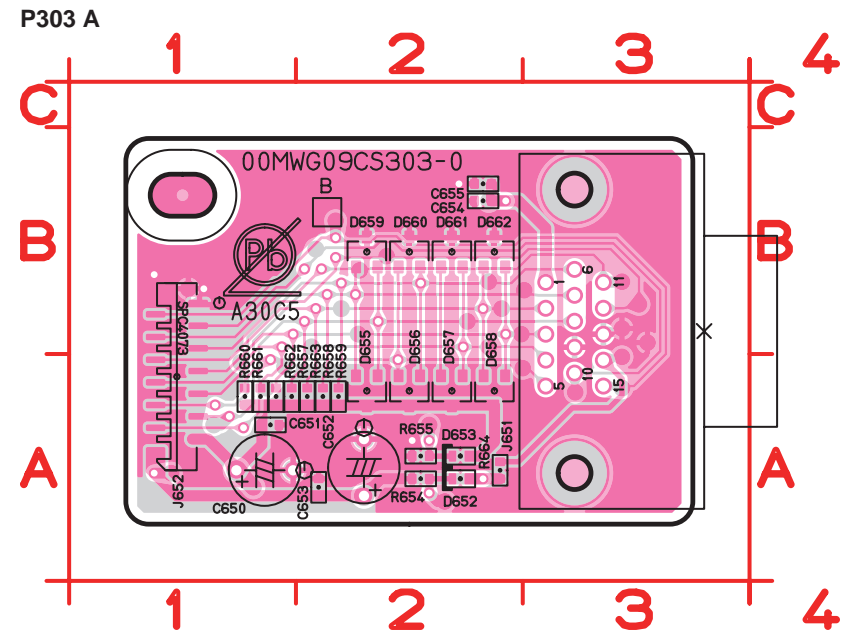

**鉛フリー半田**  
半田付けには、鉛フリー半田 (Sn-Ag-Cu) を使用してください。

**Lead-free Solder**  
When soldering, use the Lead-free Solder (Sn-Ag-Cu).



## 10. PACKING AND PARTS LIST

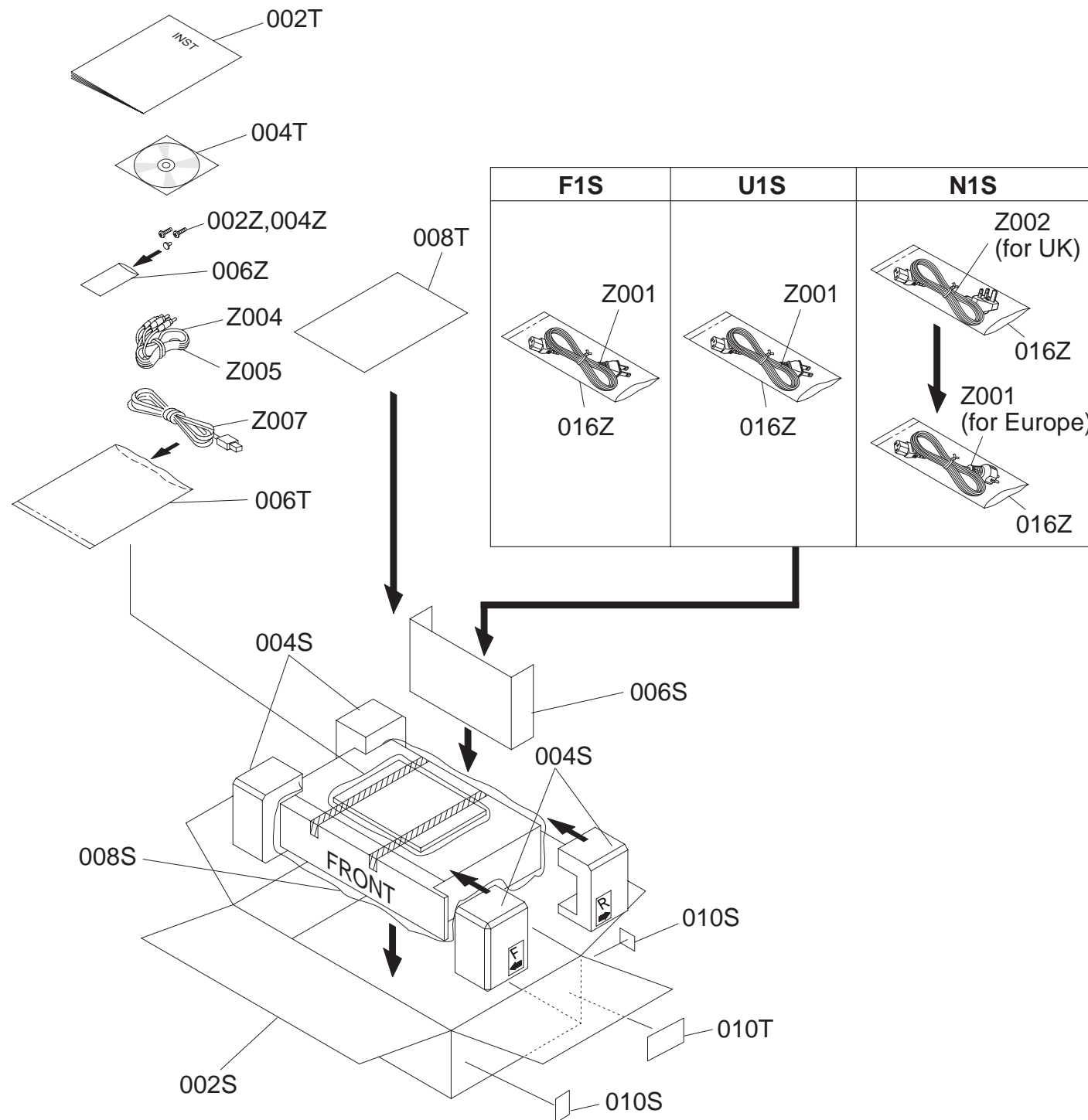

POS. NO.	VERS. COLOR	QTY	PART NO.	PART NAME	DESCRIPTION
006B		1	00M238H355020	LENS	LENS ACCESS LED
008B		2	00M204N122110	ADHESIVE	ADHESIVE FOR LENS
010B		1	00M09CS105022	FRONT CHASSIS	FRONT INNER CHASSIS
014B		1	00M43BS160010	HP BRACKET	HP BRACKET FOR HP PWB
018B		1	00M43BS154220	HP VOL KNOB SILVER	HP VOL KNOB
024B		1	00M09CS162010	DOOR	CF DOOR
025B		1	00M20BS861050	CF CAUTION LABEL	LABEL FOR CF DOOR
026B		1	00M2912259020	ACCESSORY	HOLE BUSH FOR CF DOOR
028B		2	00M49AS112010	SHAFT	SHAFT CF DOOR
030B		3	00M39BS270010	BUTTON	BUTTON:SHIFT/EDIT/LOCK
032B		1	00M43BS158110	WINDOW	LCD WINDOW
034B		1	00M43BS056010	BUFFER	BUFFER FOR F, CHASSIS LCD WINDOW
040B		1	00M39BS158020	LED WINDOW	LEVEL WINDOW
042B		1	00M09CS270013	BUTTON	BUTTON 4PCS
044B		1	412510001004P	JOG KNOB	JOG KNOB
046B		1	00M43BS270250	BUTTON SILVER	POWER BUTTON
048B		1	00M43BS121012	LINK	POWER BUTTON LINK
054B		1	00M09CS067010	USB B CAP	USB B CAP
056B		2	456110001008P	ADHESIVE	ADHESIVE
002G		1	00M43BS105213	MAIN CHASSIS	MAIN CHASSIS
004G		4	00M416H057010	LEG	LEG
020G		1	00M371K010020	SCREW	GND SCREW
022G		1	00M54050400R0	SCREW	GND WASHER
926G		1	00D1290272003	RJ45 DUST COVER(DCMJST)	FOR LAN CONNECTOR
928G		1	00D1290272003	RJ45 DUST COVER(DCMJST)	FOR LAN CONNECTOR
009L	/N1S	1	00M43BS861050		
<b>PACKING</b>					
002T	/F1S	1	00M09CS851110	USER MANUAL(F)	USER MANUAL(F)
002T	/N1S	1	00M09CS851250	USER MANUAL(U,N)	USER MANUAL(U,N)
002T	/U1S	1	00M09CS851250	USER MANUAL(U,N)	USER MANUAL(U,N)
004T	/N1S	1	00M09CS851010	USER MANUAL(CD-ROM)	USER MANUAL(CD-ROM)
004T	/U1S	1	00M09CS851010	USER MANUAL(CD-ROM)	USER MANUAL(CD-ROM)
Z001	/F1S	1	00MZC02001220	# VCTF 3 X 2.00 3P FOR JAPAN	
Z001	/N1S	1	00MZC02003190	# AC CORD 3P FOR N 10A 250V AC	# AC CORD 3P FOR N 10A 250V AC
Z001	/U1S	1	00MZC01802110	# AC CORD 3P FOR U 10A 125V AC	# AC CORD 3P FOR U 10A 125V AC
Z002	/N1S	1	00MZC01804100	AC 250V 10A FOR UK	
Z008	/F1S	1	00MYP04000830	KPR-25 AC ADAPTOR DENTORI	KPR-25 AC ADAPTOR DENTORI



# 11. IC DATA

## 78Q2120

PACKAGE PIN DESIGNATIONS  
(TOP VIEW)

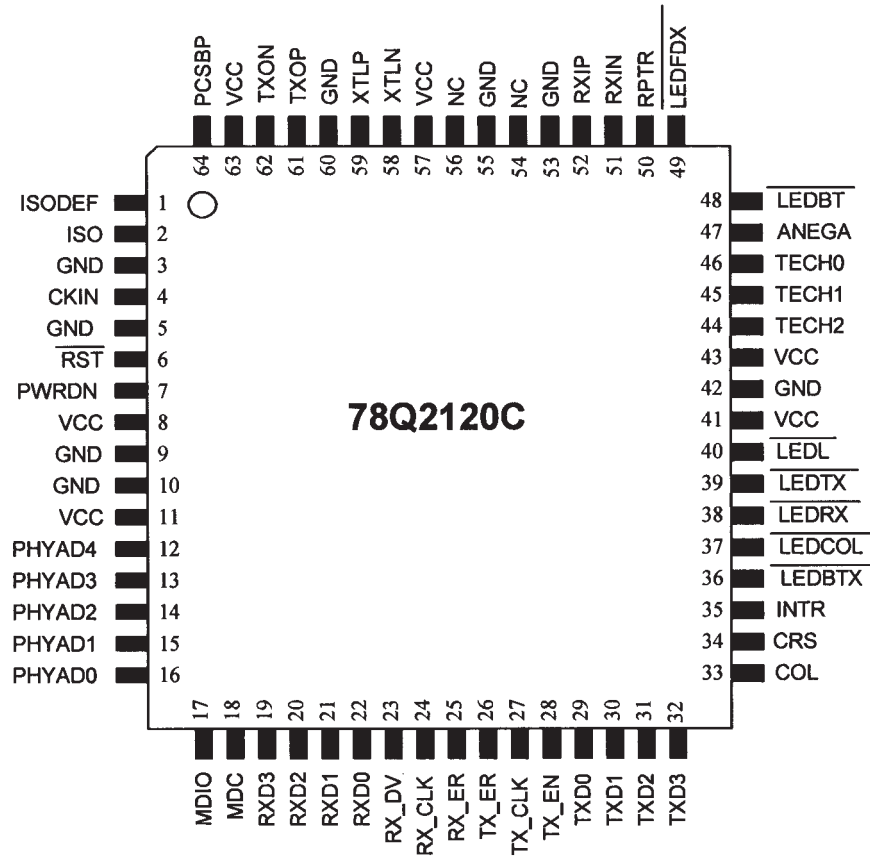

## AT24C16B

PIN CONFIGURATION

Pin Name	Function
A0 - A2	No Connect
SDA	Serial Data
SCL	Serial Clock Input
WP	Write Protect
GND	Ground
VCC	Power Supply

8-LEAD SOIC

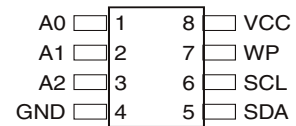

**CS4271**

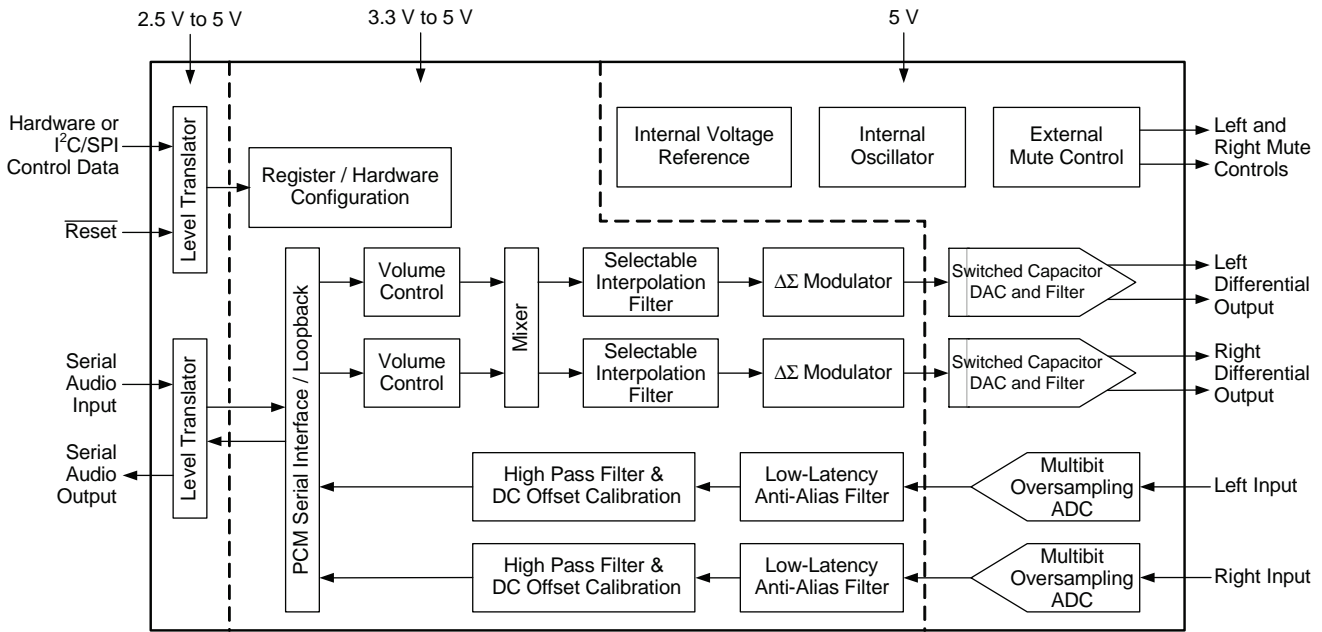

**PIN DESCRIPTION**

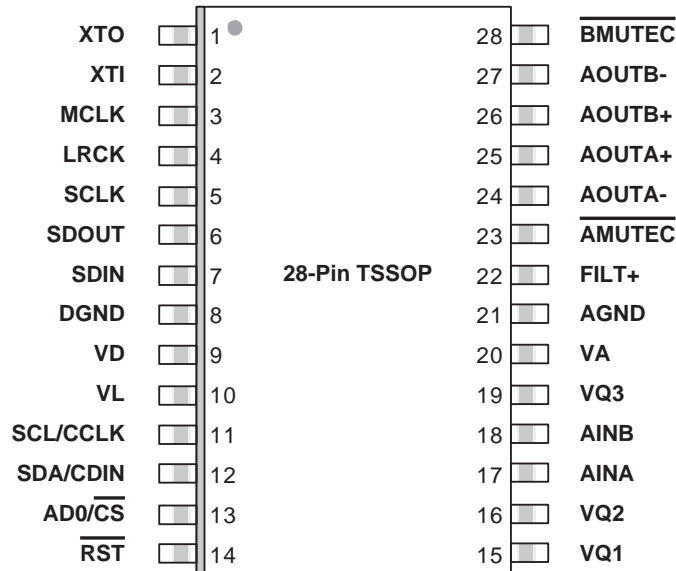

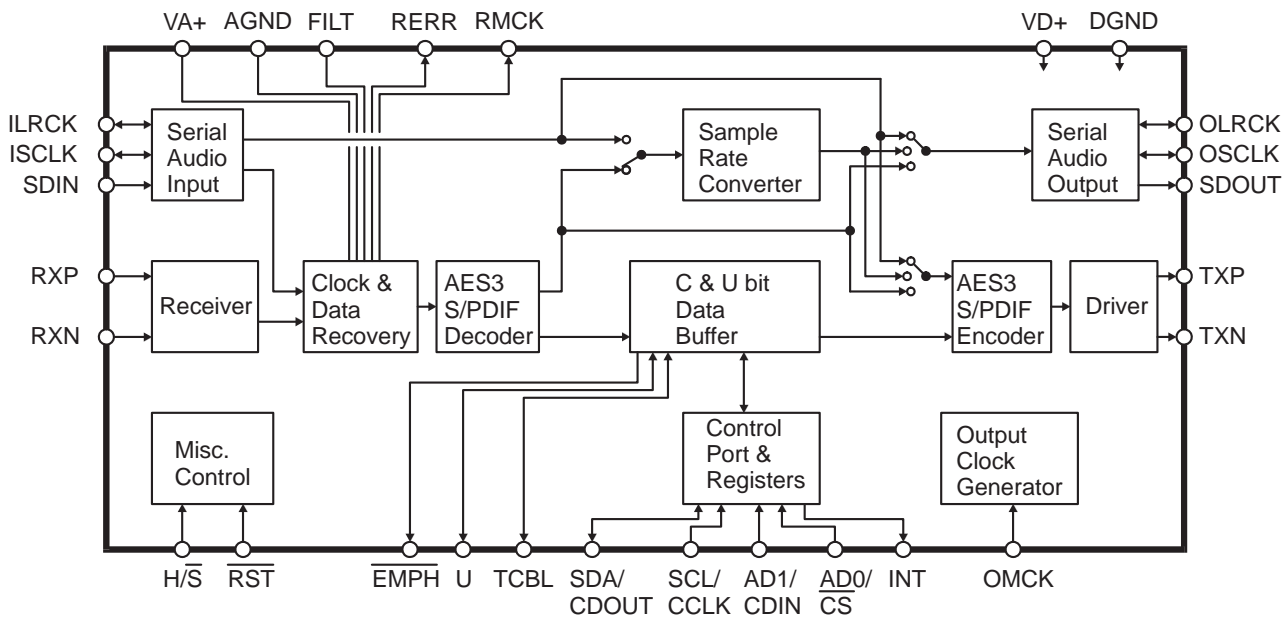

PIN DESCRIPTION

SDA/CDOUT	1 ●	28	SCL/CCLK
AD0/CS	2	27	AD1/CDIN
EMPH	3+	26	TXP
RXP	4	25	TXN
RXN	5	*24	H/S
VA+	6*	*23	VD+
AGND	7*	*22	DGND
FILT	8*	21	OMCK
RST	9*	20	U
RMCK	10	19	INT
RERR	11	18	SDOUT
ILRCK	12	17	OLRCK
ISCLK	13	16	OSCLK
SDIN	14	15	TCBL

\* Pins which remain the same function in all modes.

+ Pins which require a pull up or pull down resistor to select the desired startup option.

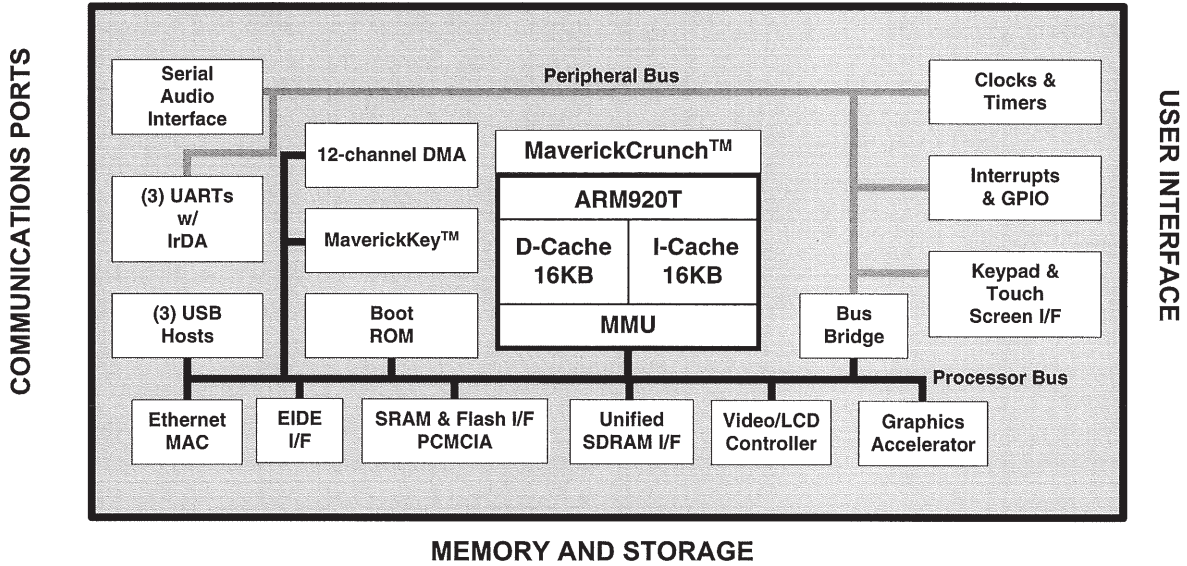

PIN BGA PINOUT

	1	2	3	4	5	6	7	8	9	10	11	12	13	14	15	16	17	18	19	20	
Y	HSYNC	DD[1]	DD[12]	P[2]	AD[15]	DA[6]	DA[4]	AD[10]	DA[1]	AD[8]	IDEDA[0]	DTRN	TDO	BOOT[0]	EEDAT	ASDO	SFRM1	RDLED	USBP[1]	ABITCLK	Y
W	P[12]	P[9]	DD[0]	P[5]	P[3]	DA[7]	DA[5]	AD[11]	AD[9]	IDES1N	IDEDA[1]	TCK	TMS	EECLK	SCLK1	GRLED	INT[3]	SLA[1]	SLA[0]	RXD[2]	W
V	P[16]	P[11]	P[8]	DD[15]	DD[13]	P[1]	AD[14]	AD[12]	DA[2]	IDES0N	IDEDA[2]	TDI	GND	ASYN	SSPTX1	INT[2]	RTSN	USBP[0]	CTSN	TXD[0]	V
U	AD[0]	P[15]	P[10]	P[7]	P[6]	P[4]	P[0]	AD[13]	DA[3]	DA[0]	DSRN	BOOT[1]	NC	SSPRX1	INT[1]	PWMOUT	USBM[0]	RXD[1]	TXD[1]	ROW[1]	U
T	DA[8]	BLANK	P[13]	SPCLK	V_CSYNC	DD[14]	GND	CVD	RVDD	GND	GND	RVDD	CVDD	GND	INT[0]	USBM[1]	RXD[0]	TXD[2]	ROW[2]	ROW[4]	T
R	AD[2]	AD[1]	P[17]	P[14]	RVDD	RVDD	GND	CVD					CVDD	GND	RVDD	RVDD	ROW[0]	ROW[3]	PLL_GND	ROW[5]	R
P	AD[4]	DA[10]	DA[9]	BRIGHT	RVDD	RVDD									RVDD	RVDD	XTALI	PLL_VDD	ROW[6]	ROW[7]	P
N	DA[13]	DA[12]	DA[11]	AD[3]	CVDD	CVD		GND	GND	GND	GND	GND	GND		GND	GND	XTALO	COL[0]	COL[1]	COL[2]	N
M	AD[7]	DA[14]	AD[6]	AD[5]	CVDD			GND	GND	GND	GND	GND	GND			GND	COL[4]	COL[3]	COL[6]	CSN[0]	M
L	DA[18]	DA[17]	DA[16]	DA[15]	GND			GND	GND	GND	GND	GND	GND			CVDD	COL[5]	COL[7]	RSTON	PRSTN	L
K	AD[22]	DA[20]	AD[21]	DA[19]	RVDD			GND	GND	GND	GND	GND	GND			CVDD	SYM	SYP	SXM	SXP	K
J	DA[21]	DQMN[0]	DQMN[1]	DQMN[2]	GND			GND	GND	GND	GND	GND	GND			CVDD	RTCXTALI	XM	YP	YM	J
H	DQMN[3]	CASN	RASN	SDCSN[2]	CVDD			GND	GND	GND	GND	GND	GND			RVDD	RTCXTALO	ADC_VDD	ADC_GND	XP	H
G	SDCSN[0]	SDCSN[1]	SDWEN	SDCLK	RVDD	RVDD									RVDD	RVDD	EGPIO[7]	EGPIO[9]	EGPIO[10]	EGPIO[11]	G
F	SDCSN[3]	DA[22]	DA[24]	AD[25]	RVDD	GND	CVD							CVDD	GND	GND	EGPIO[2]	EGPIO[4]	EGPIO[6]	EGPIO[8]	F
E	AD[23]	DA[23]	DA[26]	CSN[6]	GND	GND	CVD	CVD	RVDD	GND	GND	RVDD	CVDD	CVDD	GND	ASDI	DIOWN	EGPIO[0]	EGPIO[3]	EGPIO[5]	E
D	AD[24]	DA[25]	DD[11]	SDCLKEN	AD[19]	DD[9]	DD[5]	AD[16]	MIIRXD[2]	MIITXD[3]	TXEN	MCWAI TN	MCDAE NN	MCADEN NN	EGPIO[14]	WP	USBM[2]	ARSTN	DIORN	EGPIO[1]	D
C	CSN[1]	CSN[3]	AD[20]	DA[29]	DD[10]	DD[6]	DD[2]	MDC	MIIRXD[3]	TXCLK	MIITXD[0]	READY	MCD2	MCDIR	MCELN	IORDN	MCWRN	USBP[2]	IORDY	DMACKN	C
B	CSN[2]	DA[31]	DA[30]	DA[27]	DD[7]	DD[3]	WRN	MDIO	MIIRXD[1]	RXERR	MIITXD[1]	CRS	VS1	MCD1	MCBVD2	MCEHN	EGPIO[13]	MCRDN	WAITN	TRSTN	B
A	CSN[7]	DA[28]	AD[18]	DD[8]	DD[4]	AD[17]	RDN	RXCLK	MIIRXD[0]	RXDVAL	MIITXD[2]	TXERR	CLD	VS2	MCBVD1	MCREGN	EGPIO[12]	EGPIO[15]	IOWRN	MCRESN	A
	1	2	3	4	5	6	7	8	9	10	11	12	13	14	15	16	17	18	19	20	



ISP1582

BLOCK DIAGRAM

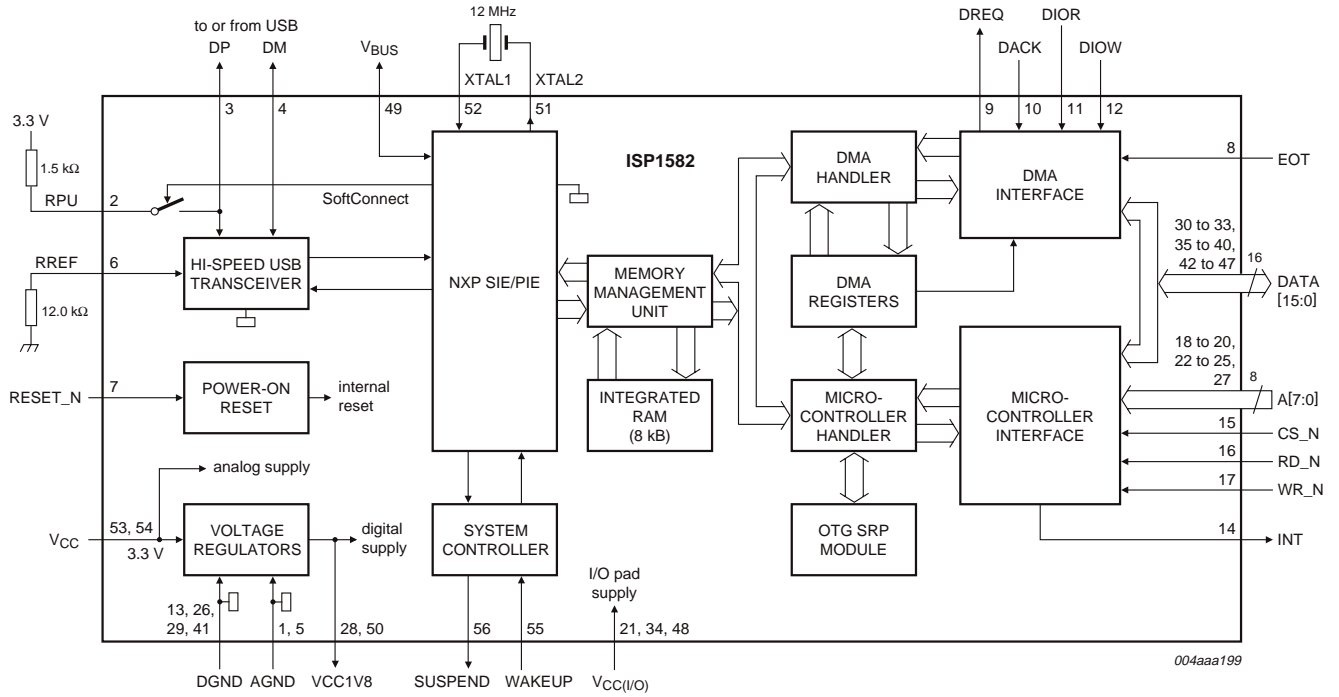

PIN CONFIGURATION

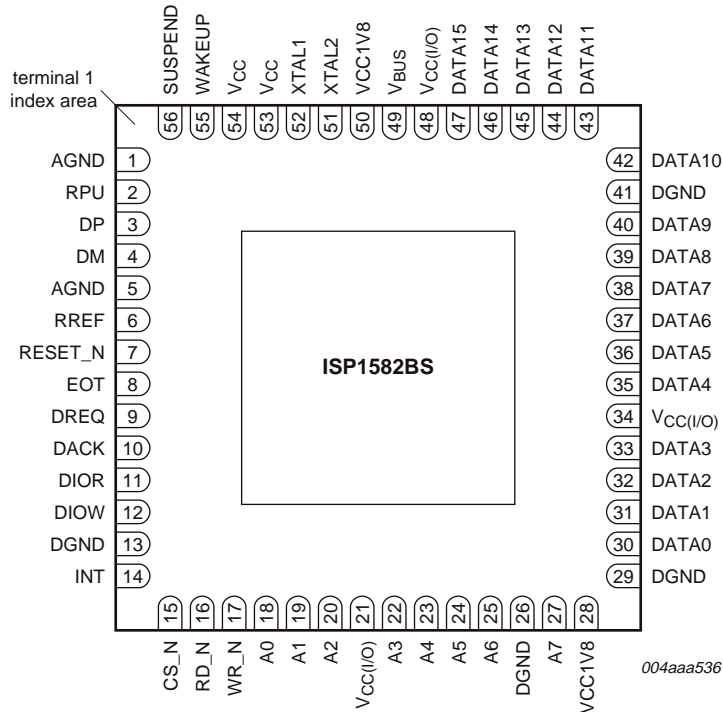

56-LEAD TSOP PINOUT (64/128/256-MBIT)

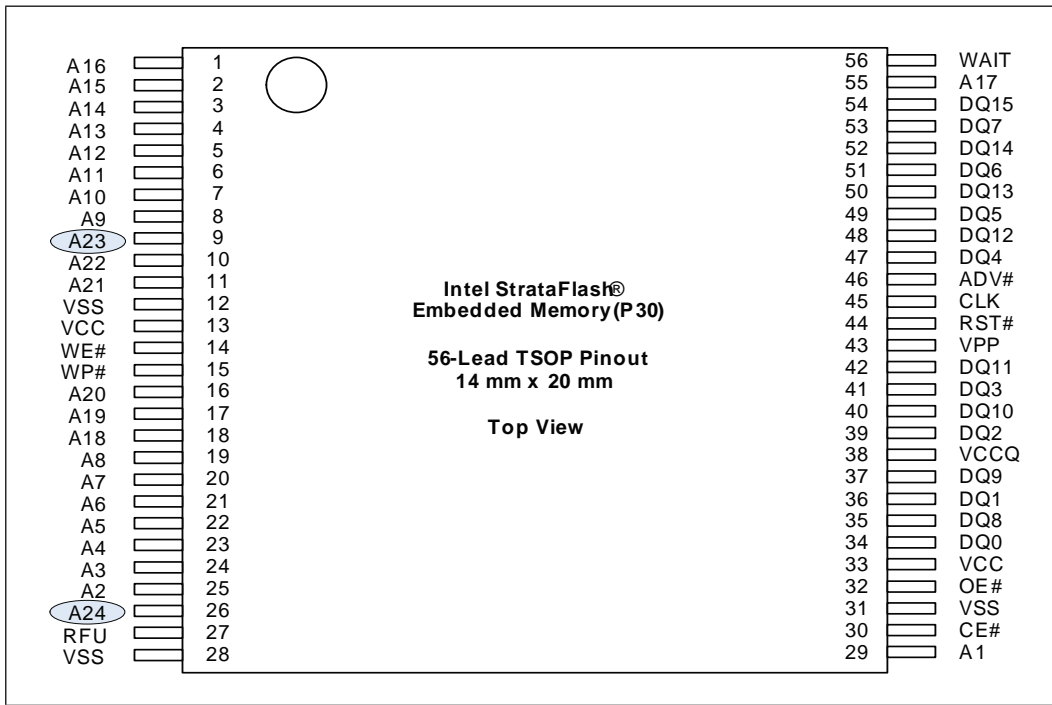

**Notes:**

1. A1 is the least significant address bit.
2. A23 is valid for 128-Mbit densities and above; otherwise, it is a no connect (NC).
3. A24 is valid for 256-Mbit densities; otherwise, it is a no connect (NC).
4. Synchronous burst read operation is currently not supported for the TSOP package. The synchronous read input signals (i.e. ADV# and CLK) should be tied off to support asynchronous reads.

**LC78211**

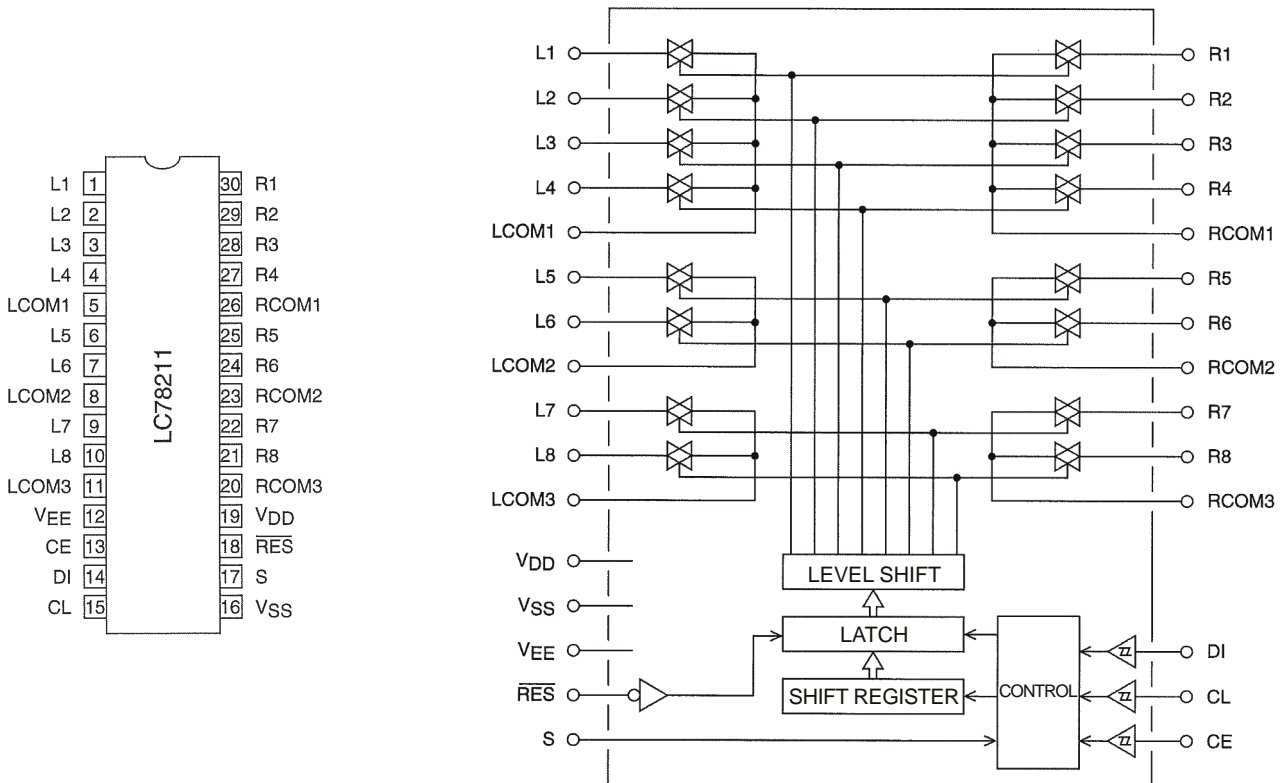

MT48LC64M4A2

Pin Assignment (Top View) 54-Pin TSOP

x4	x8	x16				x16	x8	x4
-	-	VDD	1	•	54	Vss	-	-
NC	DQ0	DQ0	2		53	DQ15	DQ7	NC
-	-	VDDQ	3		52	VssQ	-	-
NC	NC	DQ1	4		51	DQ14	NC	NC
DQ0	DQ1	DQ2	5		50	DQ13	DQ6	DQ3
-	-	VssQ	6		49	VDDQ	-	-
NC	NC	DQ3	7		48	DQ12	NC	NC
NC	DQ2	DQ4	8		47	DQ11	DQ5	NC
-	-	VDDQ	9		46	VssQ	-	-
NC	NC	DQ5	10		45	DQ10	NC	NC
DQ1	DQ3	DQ6	11		44	DQ9	DQ4	DQ2
-	-	VssQ	12		43	VDDQ	-	-
NC	NC	DQ7	13		42	DQ8	NC	NC
-	-	VDD	14		41	Vss	-	-
NC	NC	DQML	15		40	NC	-	-
-	-	WE#	16		39	DQMH	DQM	DQM
-	-	CAS#	17		38	CLK	-	-
-	-	RAS#	18		37	CKE	-	-
-	-	CS#	19		36	A12	-	-
-	-	BA0	20		35	A11	-	-
-	-	BA1	21		34	A9	-	-
-	-	A10	22		33	A8	-	-
-	-	A0	23		32	A7	-	-
-	-	A1	24		31	A6	-	-
-	-	A2	25		30	A5	-	-
-	-	A3	26		29	A4	-	-
-	-	VDD	27		28	Vss	-	-

Note: The # symbol indicates signal is active LOW. A dash (-) indicates x8 and x4 pin function is same as x16 pin function.

RS5C372A

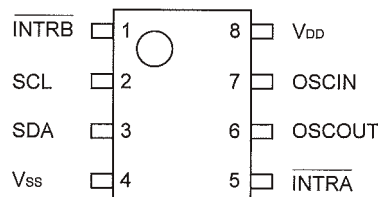
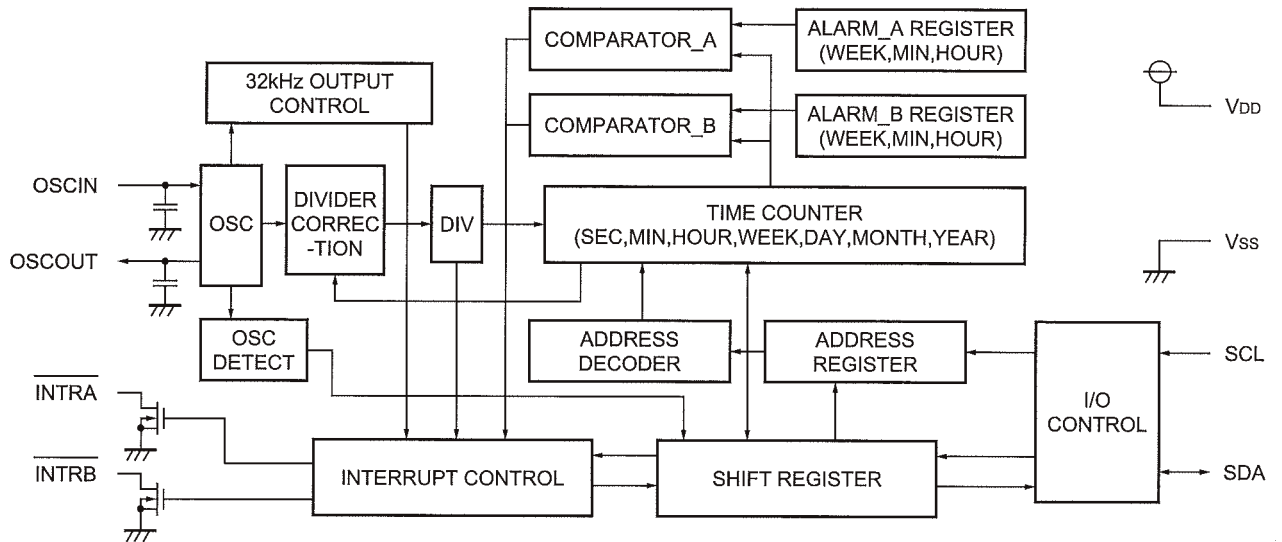

**SN65LVDM179**

(TOP VIEW)

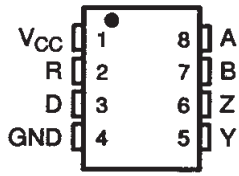

FUNCTION TABLE

Receiver

INPUTS	OUTPUT
$V_{ID} = V_A - V_B$	R
$V_{ID} \geq 50 \text{ mV}$	H
$-50 \text{ mV} < V_{ID} < 50 \text{ mV}$	?
$V_{ID} \leq -50 \text{ mV}$	L
Open	H

H = "H" Level, L = "L" Level, ? = indeterminate

Driver

INPUT	OUTPUTS	
D	Y	Z
L	L	H
H	H	L
Open	L	H

H = "H" Level, L = "L" Level

**SN65LVDS3487**

(TOP VIEW)

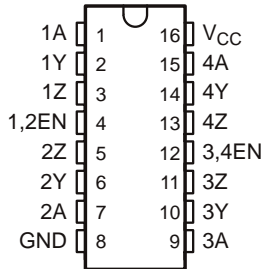

LOGIC DIAGRAM

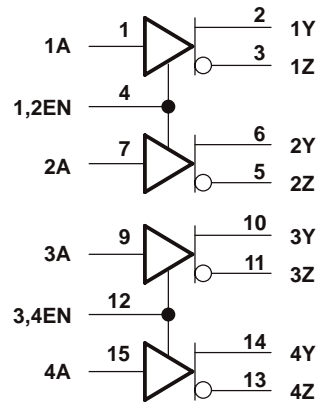

SN74LV04A

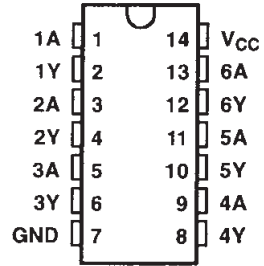

FUNCTION TABLE

INPUT A	OUTPUT Y
H	L
L	H

H : High Level

L : Low Level

SN74LV125A

(TOP VIEW)

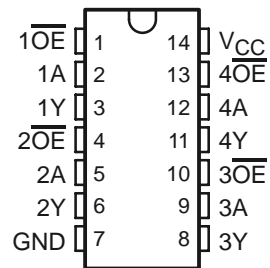

LOGIC DIAGRAM (POSITIVE LOGIC)

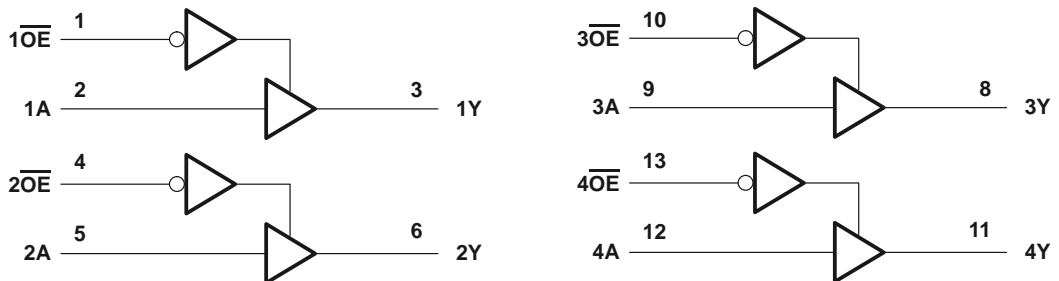

SN74LV138A

(TOP VIEW)

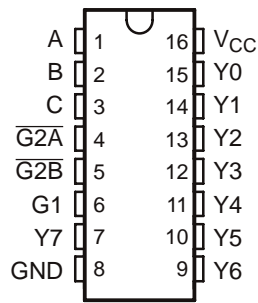

FUNCTION TABLE

ENABLE INPUTS			SELECT INPUTS			OUTPUTS							
G1	G2A	G2B	C	B	A	Y0	Y1	Y2	Y3	Y4	Y5	Y6	Y7
X	H	X	X	X	X	H	H	H	H	H	H	H	H
X	X	H	X	X	X	H	H	H	H	H	H	H	H
L	X	X	X	X	X	H	H	H	H	H	H	H	H
H	L	L	L	L	L	L	H	H	H	H	H	H	H
H	L	L	L	L	H	H	L	H	H	H	H	H	H
H	L	L	L	H	L	H	H	L	H	H	H	H	H
H	L	L	L	H	H	H	H	H	L	H	H	H	H
H	L	L	H	L	L	H	H	H	H	H	L	H	H
H	L	L	H	H	L	H	H	H	H	H	H	L	H
H	L	L	H	H	H	H	H	H	H	H	H	H	L

SN74LV244A

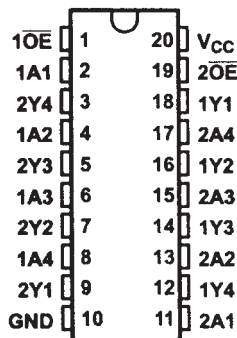

FUNCTION TABLE

INPUTS		OUTPUT
OE	A	Y
L	H	H
L	L	L
H	X	Z

H : High Level

L : Low Level

X : Don't care

Z : High impedance

SN74LV273A

(TOP VIEW)

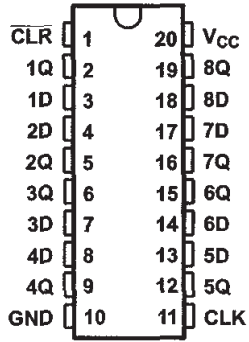

FUNCTION TABLE

INPUTS			OUTPUT
CLR	CLK	D	Q
L	X	X	L
H	↑	H	H
H	↑	L	L
H	↓	X	Q <sub>0</sub>

H : High Level  
 L : Low Level  
 X : Don't care

SN74LV541A

(TOP VIEW)

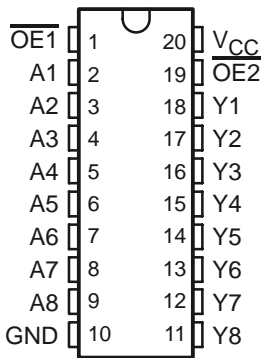

FUNCTION TABLE

(each buffer/driver)

INPUTS			OUTPUT
OE1	OE2	A	Y
L	L	L	L
L	L	H	H
H	X	X	Z
X	H	X	Z

LOGIC DIAGRAM (POSITIVE LOGIC)

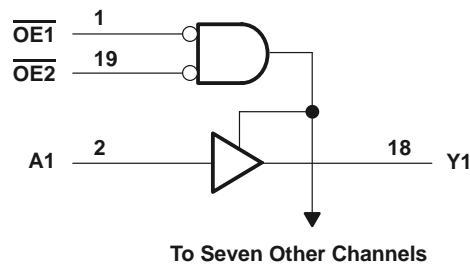

**TC74HCU04A**

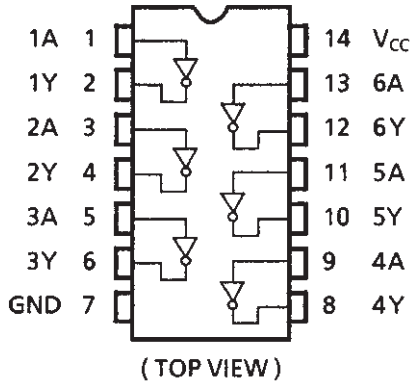

A	Y
L	H
H	L

**TC74LCX16244**

(TOP VIEW)

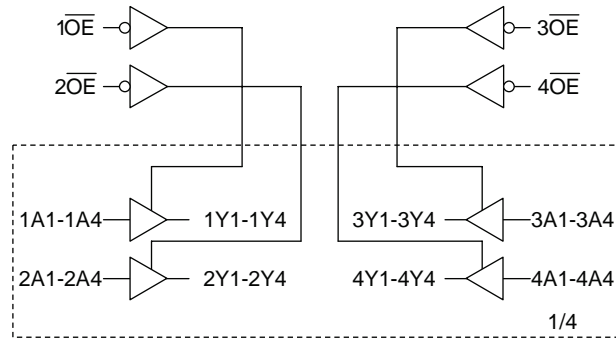
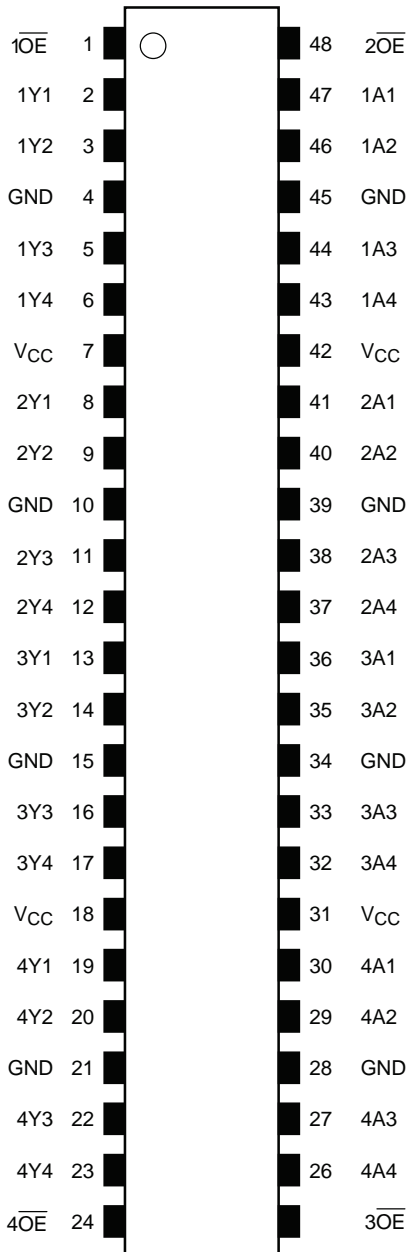



**TC74LCX16245**

(TOP VIEW)

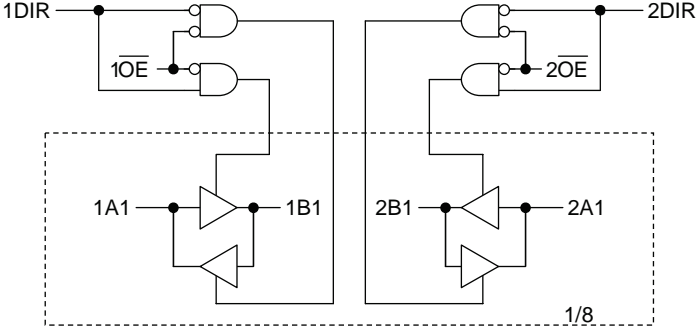
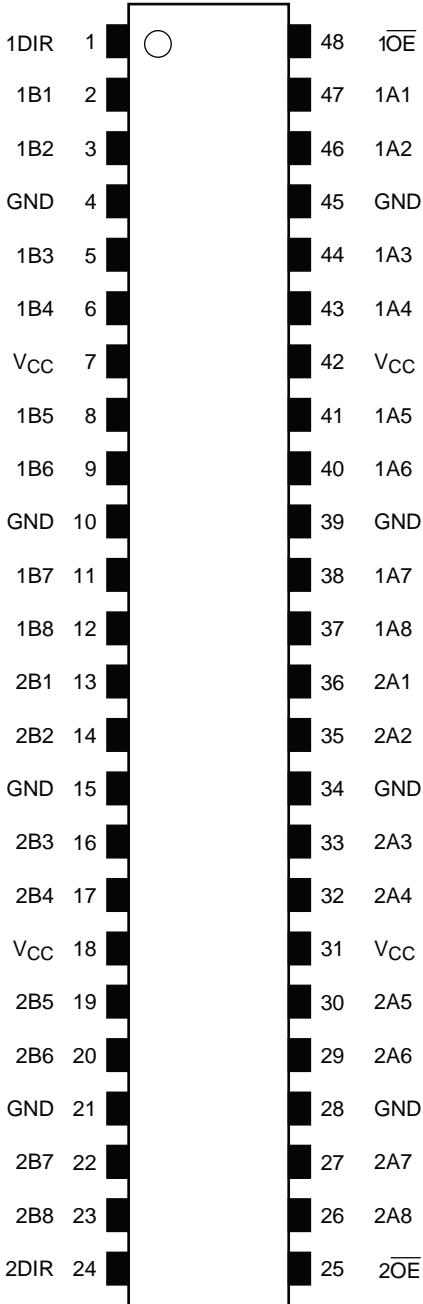

(TOP VIEW)

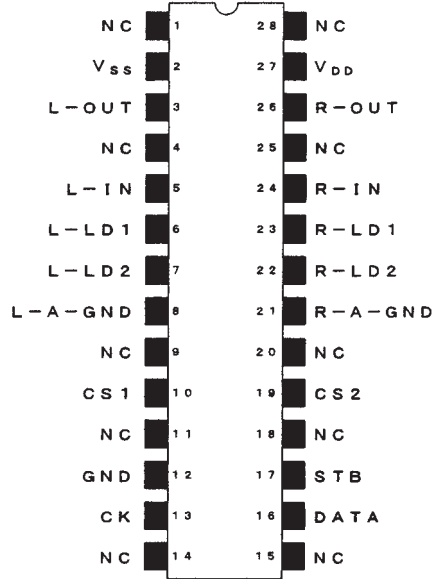

BLOCK DIAGRAM

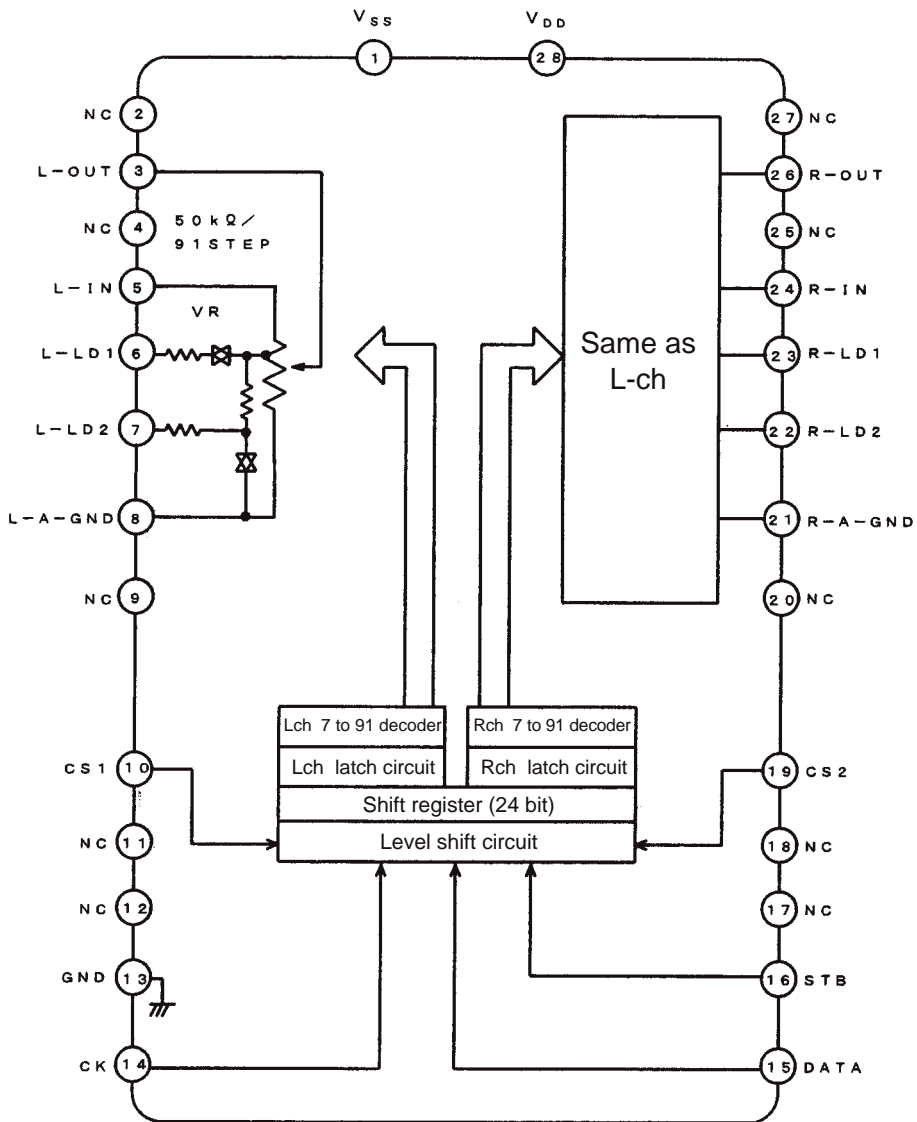

uPD4721

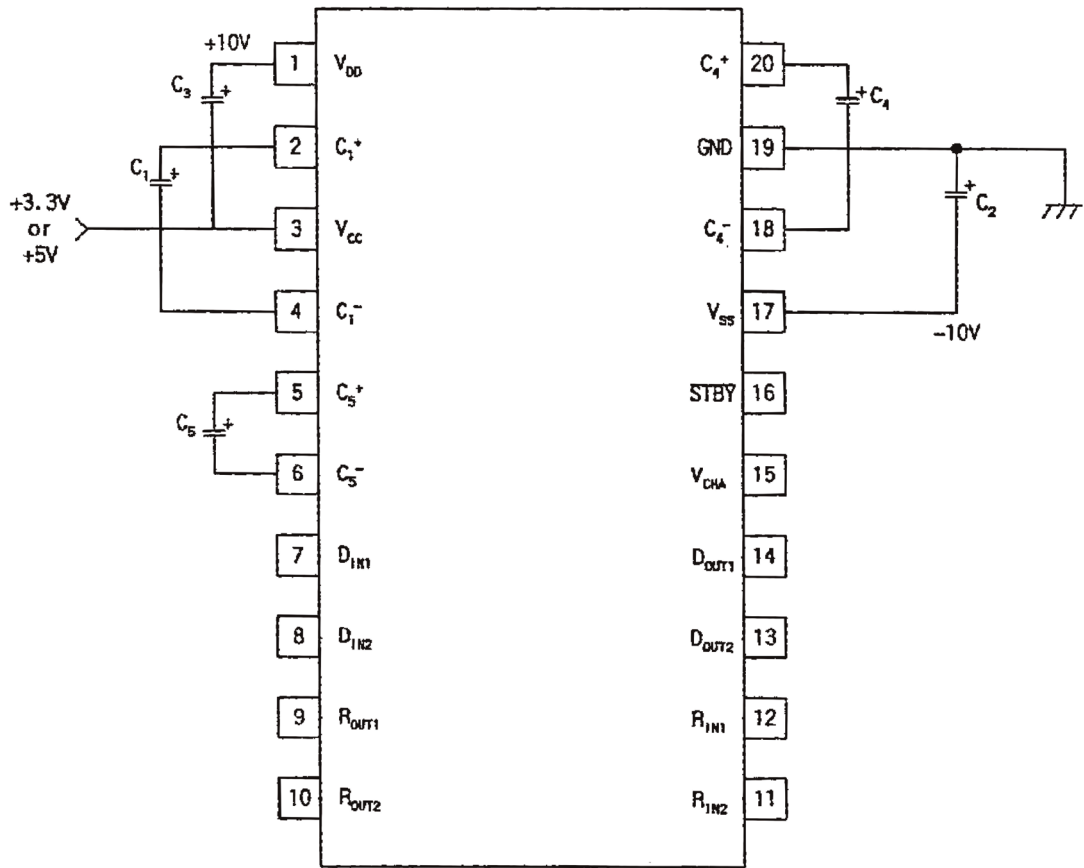

EC11B15242AE

轴回转方向 Shaft rotational direction	信号 Signal	输出波形 Output
顺转方向 C. W.	A (A-C端子圈) A(Terminal A-C)	OFF ON - [Square wave pulse]
	B (B-C端子圈) B(Terminal B-C)	OFF ON - [Square wave pulse]
反转方向 C. C. W.	A (A-C端子圈) A(Terminal A-C)	OFF ON - [Square wave pulse]
	B (B-C端子圈) B(Terminal B-C)	OFF ON - [Square wave pulse]

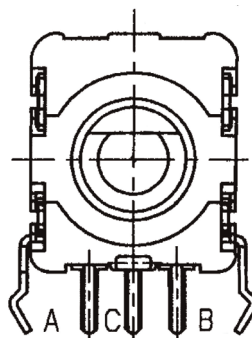

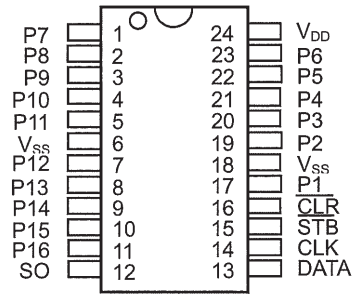

BLOCK DIAGRAM

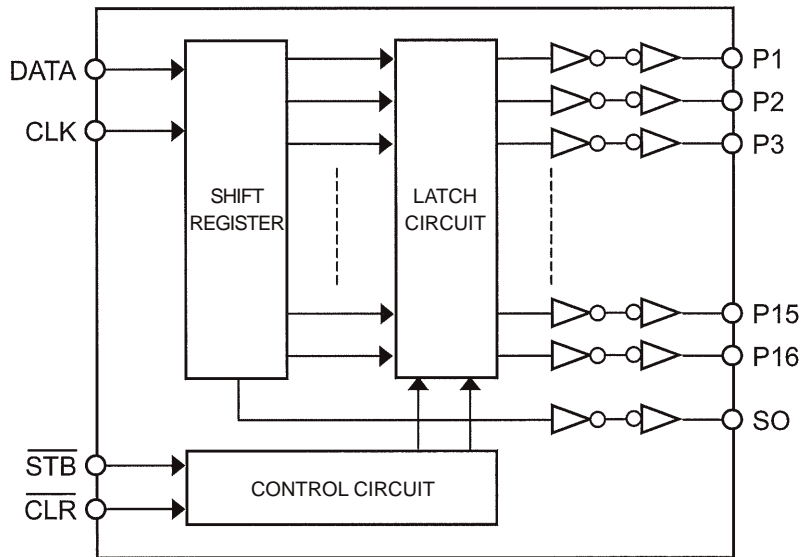

BLOCK DIAGRAM

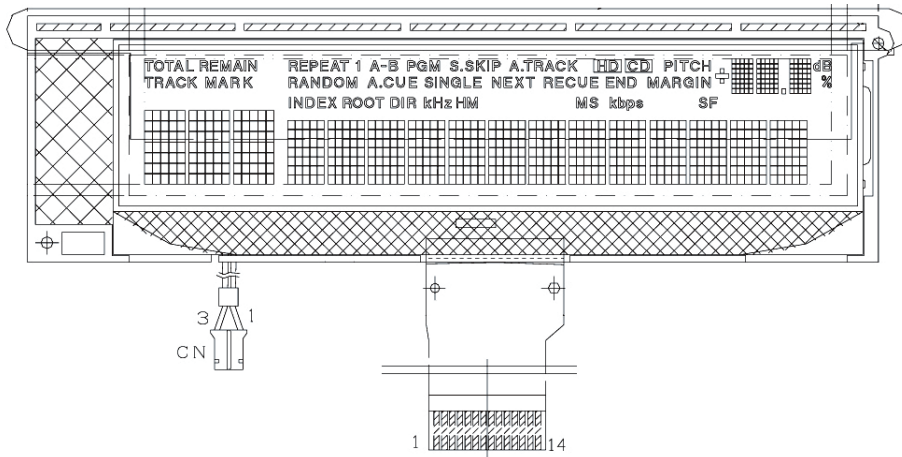
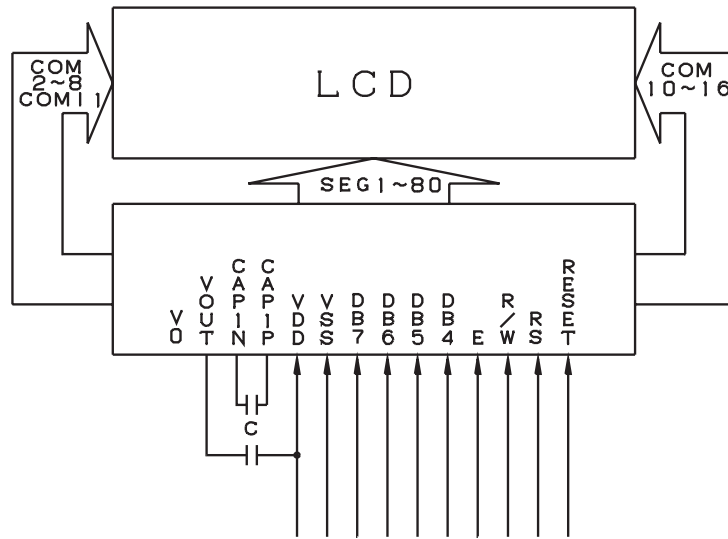

PIN CONFIGURATION

LCD Connector	
Pin No.	Signal
1	V0
2	VOUT
3	CAP1N
4	CAP1P
5	VDD
6	VSS
7	DB7
8	DB6
9	DB5
10	DB4
11	E
12	R/W
13	RS
14	RESET

Backlight Power Supply Connector	
Pin No.	Name
1	ANODE
2	NC
3	CATHODE

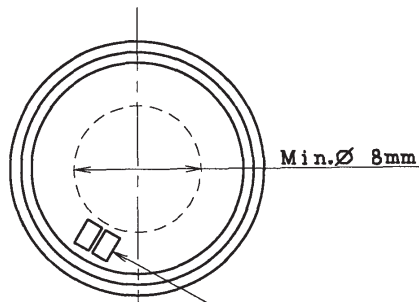
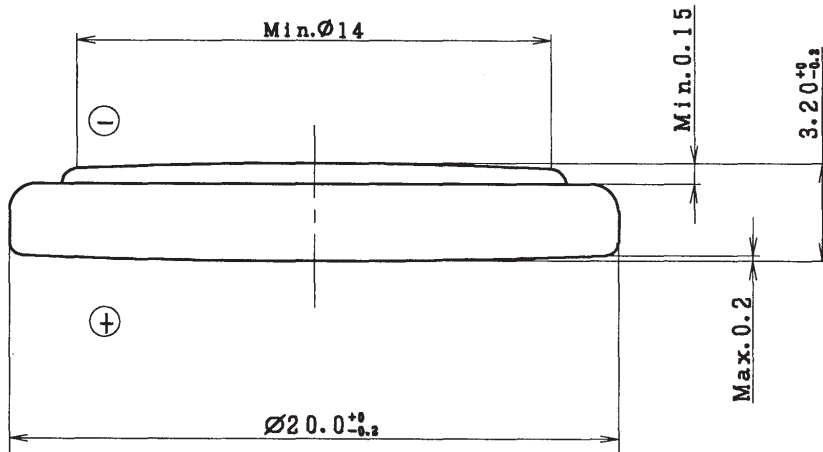

2文字を捺印  
捺印表示例：4 1  
4 = 2004年  
1 = 1月

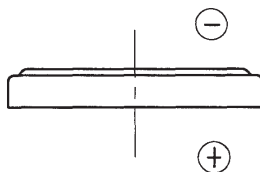

製造ロット記号  
1文字目：年    2003年=3  
                  2004年=4  
                  2005年=5  
2文字目：月    1月=1  
                  2月=2  
                  :  
                  10月=0  
                  11月=Y  
                  12月=Z

The exchange of the battery (IEC60065, UL60065).  
**CAUTION**  
Danger of explosion if battery is incorrectly replaced.  
Replace only with the same or equivalent type.



電池 (IEC60065, UL60065) の交換について  
注意  
電池を誤って交換すると爆発する危険があります。  
同一又は同等の型のものにのみ交換してください。

## 12. ELECTRICAL PARTS LIST

### PARTS INFORMATION

ABBREVIATION AND MARKS	
ANT. : ANTENNA	BATT. : BATTERY
CAP. : CAPACITOR	CER. : CERAMIC
CONN. : CONNECTING	DIG. : DIGITAL
HP : HEADPHONE	MIC. : MICROPHONE
μ-PRO : MICROPROCESSOR	REC. : RECORDING
RES. : RESISTOR	SPK : SPEAKER
SW : SWITCH	TRANSF. : TRANSFORMER
TRIM. : TRIMMING	TRS. : TRANSISTOR
VAR. : VARIABLE	X'TAL : CRYSTAL

#### NOTE ON SAFETY :

Symbol  Fire or electrical shock hazard. Only original parts should be used to replaced any part marked with symbol . Any other component substitution (other than original type), may increase risk of fire or electrical shock hazard.

#### 安全上の注意 :

がついている部品は、安全上重要な部品です。必ず指定されている部品番号の部品を使用して下さい。

NOTE: "nsp" PART IS LISTED FOR REFERENCE ONLY, D&M WILL NOT SUPPLY THESE PARTS.

PWB NAME	POS. NO.	VERS. COLOR	QTY	PART NO.	PART NAME	DESCRIPTION
	▲ J700		1	00MYJ04002450	!3P AC INLET M1910-D EMUDEN	
	L710		1	00MFC50220010	TFC-16-8-16 (TROIDAL FERRITE CLAMP)	
	L720		1	00MYJ90014730	TFP2014-T	
	L730		1	00MFC20310010	FERRITE CORE : KITAGAWA FPC-31-12-3	FPC-31-12-3 Ferrite core 100MHZ >30 Ω
	V990		1	00MKZ03302210	RCU7276Y-B LCD UNIT FOR PMD580 DISPLAY	LCD UNIT
	W002		1	00MYE05040950	SRA-UL1015 AWG18 L=9CM	
	W016		1	00M43BS152010	ULTUBE (INNER DIA.Ø4.6-L36) RoHS	
	W018		1	00M43BS152010	ULTUBE (INNER DIA.Ø4.6-L36) RoHS	
	5101			99MZZ09CS1000	<b>MAIN PCB ASSY</b>	
P101	B101		1	00MYJ14000080	20H-1T (CR2032 HOLDER) SANYO	
P101	C002		1	00MEY10700620	100µF/6.3V	100µF/6.3V
P101	C004		1	00MEY10700620	100µF/6.3V	100µF/6.3V
P101	C006		1	00MEY10700620	100µF/6.3V	100µF/6.3V
P101	C007		1	00MEY10700620	100µF/6.3V	100µF/6.3V
P101	C018		1	00MEY10701620	100µF/16V	100µF/16V
P101	C087		1	00MEY10701620	100µF/16V	100µF/16V
P101	C091		1	00MEY10601620	10µF/16V	10µF/16V
P101	C100		1	00MEY10601620	10µF/16V	10µF/16V
P101	C126		1	00MEY10501670	SVSP1C 1µF/16V	SVSP1C 1µF/16V
P101	C151		1	00MEY10700620	100µF/6.3V	100µF/6.3V
P101	C152		1	00MEY10700620	100µF/6.3V	100µF/6.3V
P101	C165		1	00MEY10700620	100µF/6.3V	100µF/6.3V
P101	C168		1	00MEY10701620	100µF/16V	100µF/16V
P101	C169		1	00MEY10700620	100µF/6.3V	100µF/6.3V
P101	C179		1	00MEY10700620	100µF/6.3V	100µF/6.3V
P101	C182		1	00MEY10700620	100µF/6.3V	100µF/6.3V
P101	C420		1	00MEY10701620	100µF/16V	100µF/16V
P101	C437		1	00MEY10601620	10µF/16V	10µF/16V
P101	CU37		1	00MEL47501010	APXA100ARA4R7MD55G	4.7µF/10V (PXA)
P101	D006		1	00D2760683943	UDZS3.6B-TE17	
P101	D007		1	00D2760560901	DAN202KT146 +C	
P101	D013		1	00D3939631903	TLGU1002A(T02)	
P101	D014		1	00MHI10038050	TLSU1002A(T02)	
P101	D016		1	00MHZ30012060	NSAD500F SURGE ABSORBER	
P101	D018		1	00D2760833900	ESD PROTECTOR(6802)	
P101	D019		1	00D2760833900	ESD PROTECTOR(6802)	
P101	D023		1	00D2760833900	ESD PROTECTOR(6802)	
P101	D024		1	00D2760833900	ESD PROTECTOR(6802)	

NOTE : "nsp" PART IS LISTED FOR REFERENCE ONLY, MARANTZ WILL NOT SUPPLY THESE PARTS.



PWB NAME	POS. NO.	VERS. COLOR	QTY	PART NO.	PART NAME	DESCRIPTION
P101	D025		1	00D2760560901	DAN202KT146 +C	DAN202K ROHM
P101	D050		1	00MHZ30018210	UDZS3.6B (3.6V ZENER DIODE)	UDZS TE-17 3.6B
P101	D051		1	00MHZ30018210	UDZS3.6B (3.6V ZENER DIODE)	UDZS TE-17 3.6B
P101	D052		1	00MHZ30018210	UDZS3.6B (3.6V ZENER DIODE)	UDZS TE-17 3.6B
P101	D053		1	00MHZ30018210	UDZS3.6B (3.6V ZENER DIODE)	UDZS TE-17 3.6B
P101	D054		1	00MHZ30018210	UDZS3.6B (3.6V ZENER DIODE)	UDZS TE-17 3.6B
P101	D055		1	00MHZ30018210	UDZS3.6B (3.6V ZENER DIODE)	UDZS TE-17 3.6B
P101	D056		1	00MHZ30018210	UDZS3.6B (3.6V ZENER DIODE)	UDZS TE-17 3.6B
P101	D057		1	00MHZ30018210	UDZS3.6B (3.6V ZENER DIODE)	UDZS TE-17 3.6B
P101	D058		1	00MHZ30018210	UDZS3.6B (3.6V ZENER DIODE)	UDZS TE-17 3.6B
P101	D059		1	00MHZ30018210	UDZS3.6B (3.6V ZENER DIODE)	UDZS TE-17 3.6B
P101	D060		1	00MHZ30018210	UDZS3.6B (3.6V ZENER DIODE)	UDZS TE-17 3.6B
P101	D061		1	00MHZ30018210	UDZS3.6B (3.6V ZENER DIODE)	UDZS TE-17 3.6B
P101	D062		1	00MHZ30018210	UDZS3.6B (3.6V ZENER DIODE)	UDZS TE-17 3.6B
P101	D063		1	00MHZ30018210	UDZS3.6B (3.6V ZENER DIODE)	UDZS TE-17 3.6B
P101	D064		1	00MHZ30018210	UDZS3.6B (3.6V ZENER DIODE)	UDZS TE-17 3.6B
P101	D065		1	00MHZ30018210	UDZS3.6B (3.6V ZENER DIODE)	UDZS TE-17 3.6B
P101	D066		1	00MHZ30018210	UDZS3.6B (3.6V ZENER DIODE)	UDZS TE-17 3.6B
P101	D067		1	00MHZ30018210	UDZS3.6B (3.6V ZENER DIODE)	UDZS TE-17 3.6B
P101	D110		1	00MHZ21005000	1SS301,DAN202U UMT TYPE	1SS301,DAN202U UMT TYPE
P101	D118		1	00D2760833900	ESD PROTECTOR(6802)	
P101	J001		1	00MYJ07019780	B8B-PH-SM4-TB (LF)(SN)	B8B-PH-SM3-TB JST
P101	J004		1	00MYJ07014260	20FMN-BMTTN-A-TFT	
P101	J007		1	00D2051072904	3P PH CON.BASE(TAPE) +REF	
P101	J008		1	00MYJ90014750	SCFB1A0500(HEADER)	
P101	J011		1	00MYJ07061010	FH12-34S-0.5SV	FH12-34S-0.5SV
P101	J012		1	00MYJ07014200	14P FFC CONNECTOR FMN-BMTTN-TP	
P101	J013		1	00D2051072917	4P PH CON BASE(TAPE) +REF	
P101	J014		1	00MYJ07014280	22FMN-BMTTN-TFT JST	22FMN-BMTTN-TFT JST
P101	J015		1	00D2051072917	4P PH CON BASE(TAPE) +REF	
P101	J051		1	00MYJ90014770	UBB-4R-D14T-4D	
P101	J052		1	00MYJ07019770	B7B-PH-SM4-TB (LF)(SN)	
P101	J088		1	00MYJ90014760	SCFB3A0300(EJECTOR)	
P101	L001		1	00MFC90020110	BLM18BD601SN1D	BLM11B601S CHIP FERRITE
P101	L002		1	00MFC90020110	BLM18BD601SN1D	BLM11B601S CHIP FERRITE
P101	L004		1	00MFC90020110	BLM18BD601SN1D	BLM11B601S CHIP FERRITE
P101	L009		1	00MFC90020110	BLM18BD601SN1D	BLM11B601S CHIP FERRITE
P101	L010		1	00MFC90020110	BLM18BD601SN1D	BLM11B601S CHIP FERRITE
P101	L011		1	00MFN31010060	BLM18PG600SN1D	EMI FILTER BLM11P600S
P101	L012		1	00MFN31010060	BLM18PG600SN1D	EMI FILTER BLM11P600S
P101	L014		1	00MFC90020110	BLM18BD601SN1D	
P101	L015		1	00MFC90020110	BLM18BD601SN1D	
P101	L016		1	00MFC90020110	BLM18BD601SN1D	
P101	L017		1	00MFC90020110	BLM18BD601SN1D	BLM11B601S CHIP FERRITE
P101	L018		1	00MFC90020110	BLM18BD601SN1D	BLM11B601S CHIP FERRITE
P101	L019		1	00MFC90020110	BLM18BD601SN1D	BLM11B601S CHIP FERRITE
P101	L112		1	00MFC90020110	BLM18BD601SN1D	BLM11B601S CHIP FERRITE
P101	L113		1	00MFC90020110	BLM18BD601SN1D	BLM11B601S CHIP FERRITE
P101	L120		1	00MFC90020110	BLM18BD601SN1D	
P101	L151		1	00MFN21010060	DLW21SN900SQ2L	DLW21SN900SQ2L

NOTE : \*nsp\* PART IS LISTED FOR REFERENCE ONLY, MARANTZ WILL NOT SUPPLY THESE PARTS.

PWB NAME	POS. NO.	VERS. COLOR	QTY	PART NO.	PART NAME	DESCRIPTION
P101	L152		1	00MFN31030030	BLM21PG600SN1D 2012 3A	BLM21PG600SN1
P101	L650		1	00MTP93570010	PULSE TRANS. TLA-6T118LF-T TDK	
P101	Q001		1	00MHC12252090	NJM2387DL2	
P101	Q002		1	00MHC12252090	NJM2387DL2	
P101	Q003		1	00MHC12252090	NJM2387DL2	
P101	Q004		1	00MHC12252090	NJM2387DL2	
P101	Q005		1	00D2622785905	SN74LV125APWRG4 +C	
P101	Q009		1	00MHC10259990	AT24C16BN-SH-T	
P101	Q010		1	00D2622515900	SN74LV04APW-EL2 +C	
P101	Q015		1	00D2622517908	SN74LV08APW-EL2 +REF	
P101	Q020		1	00MHC1048099F	MT48LC32M16A2P-75	
P101	Q021		1	00MHC1048099F	MT48LC32M16A2P-75	
P101	Q022		1	00MHJ09CSX02F	JS28F128P30T85(FOR PMD580)	JS28F128P30T85(FOR PMD580)
P101	Q024		1	00MHC10234210	BD45302G RESET 3.0V	
P101	Q026		1	00D2622785905	SN74LV125APWRG4 +C	
P101	Q029		1	00MHC10474050	TC74LCX14FT	TC74LCX14FT
P101	Q036		1	00MHC011705K0	TC74LCX00FT(EL.K)	
P101	Q037		1	00D2622514901	SN74LV138APW-EL2 +C	
P101	Q038		1	00D2622514901	SN74LV138APW-EL2 +C	
P101	Q039		1	00D2622641900	SN74LV541APW-EL2 +C	
P101	Q040		1	00D2620945909	SN7438NS-R +C	
P101	Q042		1	00MHC10003600	78Q2120C09A-64GCT (ETHERNET TRANSCEIVER)	
P101	Q043		1	00D2690083901	DTA114EKT96 +C	DTA114YK (ROHM)
P101	Q105		1	00MHC10036770	RS5C372A-E2	
P101	Q112		1	00D2622519906	SN74LV00APW-EL2 +C	
P101	Q117		1	00MHC011705K0	TC74LCX00FT(EL.K)	
P101	Q118		1	00MHC712300Z0	CMOS LOGIC IC 74HC123 (FLAT)	CMOS LOGIC IC 74HC123 (FLAT)
P101	Q119		1	00MHC011705K0	TC74LCX00FT(EL.K)	
P101	Q120		1	00MHC10244090	NJU3716AM-TE1	
P101	Q121		1	00MHC10244090	NJU3716AM-TE1	
P101	Q122		1	00MHC10488050	TC74LCX16244FT	
P101	Q123		1	00MHC10197050	TC74LCX16245FT	
P101	Q124		1	234810006503S	TC74VCX32FT	
P101	Q125		1	234810007506S	TC74VCX08FT	
P101	Q126		1	00MHX327121A0	2SC2712(G) PKG TE85L	
P101	Q157		1	00MHC10258990	MAX3207E	
P101	Q159		1	00MHC012505K0	TC7SZ32F(TE85L)	TC7SZ32F(TE85L)
P101	Q160		1	00D2623415902	TC7SZU04F	TC7SZU04F
P101	Q161		1	00D2623415902	TC7SZU04F	TC7SZU04F
P101	Q300		1	00D2622785905	SN74LV125APWRG4 +C	
P101	Q401		1	00D2690082902	DTC114EKT96 +C	
P101	Q402		1	00D2623242900	SN74LV273APW-EL2 +REF	
P101	Q403		1	00D2623242900	SN74LV273APW-EL2 +REF	
P101	Q404		1	00D2622959906	SN74LV244APW +REF	
P101	Q406		1	00MBA10012210	DTA114TU (ROHM)	
P101	R003		1	00MNI05000110	0Ω ±5% 1/10W	0 Ω ± 5% 1/10W
P101	R007		1	00MNI05047110	4.7Ω ±5% 1/10W	4.7 Ω ± 5% 1/10W

NOTE : "nsp" PART IS LISTED FOR REFERENCE ONLY, MARANTZ WILL NOT SUPPLY THESE PARTS.

PWB NAME	POS. NO.	VERS. COLOR	QTY	PART NO.	PART NAME	DESCRIPTION
P101	R008		1	00MNI05000110	0Ω ±5% 1/10W	0 Ω ± 5% 1/10W
P101	R014		1	00MNI05000110	0Ω ±5% 1/10W	0 Ω ± 5% 1/10W
P101	R256		1	00MNI05000110	0Ω ±5% 1/10W	0 Ω ± 5% 1/10W
P101	R450		1	00MNI05000110	0Ω ±5% 1/10W	0 Ω ± 5% 1/10W
P101	R451		1	00MNI05000110	0Ω ±5% 1/10W	0 Ω ± 5% 1/10W
P101	RU01		1	00MRI05000180	0Ω ±5% 1/8W	
P101	RU07		1	00MNM11202020	GRT1060120210 12kW ±1%	GRT1060120210 12K Ω ±1%
P101	RU08		1	00MRI05000180	0Ω ±5% 1/8W	
P101	RU11		1	00MRI05000180	0Ω ±5% 1/8W	0 Ω ± 5% 1/8W
P101	RU12		1	00MRI05000180	0Ω ±5% 1/8W	0 Ω ± 5% 1/8W
P101	RU74		1	00MNI05000110	0Ω ±5% 1/10W	0 Ω ± 5% 1/10W
P101	X001		1	00MJX14005100	XTAL 14.7456MHz (HC-49/U03C)	
P101	X002		1	00MJX00002460	TFX-02(32.768kHz)	
P101	X004		1	00MJX25003460	25.000MHz X'TAL (FCX-03)	
P101	X103		1	00MJX12009350	12MHz(SMD-49)	
	5200			nsp	<b>MOTHER PWB ASSY</b>	
	5201			nsp	<b>AUDIO IO PCB ASSY</b>	
P201	CA07		1	00MOA47602520	47μF M 25V RA-2	47 μF M 25V RA-2
P201	CA08		1	00MOA47602520	47μF M 25V RA-2	47 μF M 25V RA-2
P201	CA19		1	00MOA47602520	47μF M 25V RA-2	47 μF M 25V RA-2
P201	CA20		1	00MOA47602520	47μF M 25V RA-2	47 μF M 25V RA-2
P201	CA27		1	00MOA47602520	47μF M 25V RA-2	47 μF M 25V RA-2
P201	CA28		1	00MOA47602520	47μF M 25V RA-2	47 μF M 25V RA-2
P201	CA32		1	00MOA47602520	47μF M 25V RA-2	
P201	CA33		1	00MOA47602520	47μF M 25V RA-2	
P201	CA41		1	00MOA10602520	10μF M 25V RA-2	10 μF M 25V RA-2
P201	CA42		1	00MOA10602520	10μF M 25V RA-2	10 μF M 25V RA-2
P201	CA43		1	00MOA10602520	10μF M 25V RA-2	10 μF M 25V RA-2
P201	CA44		1	00MOA10602520	10μF M 25V RA-2	10 μF M 25V RA-2
P201	CA55		1	00MOA10602520	10μF M 25V RA-2	10 μF M 25V RA-2
P201	CA56		1	00MOA10602520	10μF M 25V RA-2	10 μF M 25V RA-2
P201	CA57		1	00MOA10602520	10μF M 25V RA-2	10 μF M 25V RA-2
P201	CA58		1	00MOA10602520	10μF M 25V RA-2	10 μF M 25V RA-2
P201	CA59		1	00MOA10602520	10μF M 25V RA-2	10 μF M 25V RA-2
P201	CA60		1	00MOA10602520	10μF M 25V RA-2	10 μF M 25V RA-2
P201	CA61		1	00MOA10602520	10μF M 25V RA-2	10 μF M 25V RA-2
P201	CA62		1	00MOA10602520	10μF M 25V RA-2	10 μF M 25V RA-2
P201	CA63		1	00MOA10602520	10μF M 25V RA-2	10 μF M 25V RA-2
P201	CA64		1	00MOA10602520	10μF M 25V RA-2	10 μF M 25V RA-2
P201	CA65		1	00MOA10702520	100μF M 25V RA-2	10 μF M 25V RA-2
P201	CA66		1	00MOA10702520	100μF M 25V RA-2	10 μF M 25V RA-2
P201	CA67		1	00MOA10602520	10μF M 25V RA-2	10 μF M 25V RA-2
P201	CA68		1	00MOA10602520	10μF M 25V RA-2	10 μF M 25V RA-2
P201	CA83		1	00MOA47602520	47μF M 25V RA-2	47 μF M 25V RA-2
P201	CA84		1	00MOA47602520	47μF M 25V RA-2	47 μF M 25V RA-2
P201	CA89		1	00MOA47602520	47μF M 25V RA-2	47 μF M 25V RA-2
P201	CA90		1	00MOA47602520	47μF M 25V RA-2	47 μF M 25V RA-2

NOTE : "nsp" PART IS LISTED FOR REFERENCE ONLY, MARANTZ WILL NOT SUPPLY THESE PARTS.

PWB NAME	POS. NO.	VERS. COLOR	QTY	PART NO.	PART NAME	DESCRIPTION
P201	CA91		1	00MOA10702520	100µF M 25V RA-2	
P201	CA92		1	00MOA10702520	100µF M 25V RA-2	
P201	CA94		1	00MOA10702520	100µF M 25V RA-2	
P201	CB13		1	00MOA10702520	100µF M 25V RA-2	
P201	CB14		1	00MOA10702520	100µF M 25V RA-2	
P201	CB15		1	00MOA10702520	100µF M 25V RA-2	
P201	CB16		1	00MOA10702520	100µF M 25V RA-2	
P201	CB25		1	00MOA47602520	47µF M 25V RA-2	47 µF M 25V RA-2
P201	CB26		1	00MOA47602520	47µF M 25V RA-2	47 µF M 25V RA-2
P201	CB31		1	00MOA10702520	100µF M 25V RA-2	
P201	CB32		1	00MOA10702520	100µF M 25V RA-2	
P201	CB38		1	00MOA10602520	10µF M 25V RA-2	10 µF M 25V RA-2
P201	CB39		1	00MOA10602520	10µF M 25V RA-2	10 µF M 25V RA-2
P201	CB44		1	00MOA47602520	47µF M 25V RA-2	
P201	CB45		1	00MOA47602520	47µF M 25V RA-2	
P201	CB52		1	00MOA10602520	10µF M 25V RA-2	10 µF M 25V RA-2
P201	CB53		1	00MOA10602520	10µF M 25V RA-2	10 µF M 25V RA-2
P201	CB54		1	00MOA47602520	47µF M 25V RA-2	47 µF M 25V RA-2
P201	CB55		1	00MOA47602520	47µF M 25V RA-2	47 µF M 25V RA-2
P201	CB64		1	00MOA22602520	22µF M 25V RA-2	22 µF M 25V RA-2
P201	CB65		1	00MOA22602520	22µF M 25V RA-2	22 µF M 25V RA-2
P201	CB85		1	00MOA10602520	10µF M 25V RA-2	10 µF M 25V RA-2
P201	CB86		1	00MOA10602520	10µF M 25V RA-2	10 µF M 25V RA-2
P201	CD15		1	00MOA10601620	10µF M 16V RA-2	
P201	CD23		1	00MOA10702520	100µF M 25V RA-2	
P201	CD32		1	00MOA47602520	47µF M 25V RA-2	47 µF M 25V RA-2
P201	CD40		1	00MOA10702520	100µF M 25V RA-2	
P201	DA01		1	00D2760560901	DAN202KT146 +C	
P201	DA02		1	00D2760559909	DAP202KT146 +C	
P201	DA03		1	00D2760560901	DAN202KT146 +C	
P201	DA04		1	00D2760559909	DAP202KT146 +C	
P201	DA05		1	00D2760560901	DAN202KT146 +C	
P201	DA06		1	00D2760559909	DAP202KT146 +C	
P201	DA07		1	00D3939631903	TLGU1002A(T02)	
P201	DA08		1	00D2760560901	DAN202KT146 +C	
P201	DA09		1	00D2760559909	DAP202KT146 +C	
P201	DA11		1	00MHZ20018050	1SS302 (TE85L,F) (TOSHIBA)	
P201	DA12		1	00MHZ20018050	1SS302 (TE85L,F) (TOSHIBA)	
P201	DA13		1	00MHZ20018050	1SS302 (TE85L,F) (TOSHIBA)	
P201	DA14		1	00MHZ20018050	1SS302 (TE85L,F) (TOSHIBA)	
P201	DB01		1	00D2760560901	DAN202KT146 +C	
P201	DB02		1	00D2760559909	DAP202KT146 +C	
P201	DB03		1	00D2760560901	DAN202KT146 +C	
P201	DB04		1	00D2760559909	DAP202KT146 +C	
P201	DB05		1	00D2760560901	DAN202KT146 +C	
P201	DB06		1	00D2760559909	DAP202KT146 +C	
P201	DB07		1	00D2760559909	DAP202KT146 +C	
P201	DB08		1	00D2760559909	DAP202KT146 +C	

NOTE : "nsp" PART IS LISTED FOR REFERENCE ONLY, MARANTZ WILL NOT SUPPLY THESE PARTS.

PWB NAME	POS. NO.	VERS. COLOR	QTY	PART NO.	PART NAME	DESCRIPTION
P201	DC01		1	00MHI10202050	TLOU1002A(T02)	
P201	DC02		1	00D3939631903	TLGU1002A(T02)	
P201	DC03		1	00D2760560901	DAN202KT146 +C	
P201	DC04		1	00D2760559909	DAP202KT146 +C	
P201	DD01		1	00D2760560901	DAN202KT146 +C	
P201	DD02		1	00D2760559909	DAP202KT146 +C	
P201	DD03		1	00D2760560901	DAN202KT146 +C	
P201	DD04		1	00D2760559909	DAP202KT146 +C	
P201	DD05		1	00D2760560901	DAN202KT146 +C	
P201	DD06		1	00D2760559909	DAP202KT146 +C	
P201	DD07		1	00D2760833900	ESD PROTECTOR(6802)	
P201	DD08		1	00D2760833900	ESD PROTECTOR(6802)	
P201	JA01		1	00D2051254007	XLR IN (JY-5033U)	JY-5033U*030
P201	JA02		1	00D2051254007	XLR IN (JY-5033U)	JY-5033U*030
P201	JA03		1	00MYT02021200	YKC21-3091N 14X14 RA 2L2P W/R NI FLM-GND	
P201	JA04		1	00MYP06010450	B5B-EH-TS (LF)(SN) 5P RADIAL TAPING	B5B-EH 5P RADIAL TAPING
P201	JB01		1	00D2051255006	XLR OUT (JY-5032A)	JY-5032A*030
P201	JB02		1	00D2051255006	XLR OUT (JY-5032A)	JY-5032A*030
P201	JB03		1	00MYT02021200	YKC21-3091N 14X14 RA 2L2P W/R NI FLM-GND	
P201	JB04		1	00MYJ06006260	B6B-PH-K-S (LF)(SN)	HP CONNECTOR B6B-PH-K-S
P201	JC01		1	00MYJ01080220	YKB21-5265 6.3mm STEREO PHONE JACK	
P201	JC02		1	00MYJ90014700	TM11R-5M2-88-LP HIROSE RJ45 LAN	
P201	JC03		1	00MYJ07019740	B4B-PH-SM4-TB (LF)(SN)	LAN CONNECTOR B4B-PH-SM4
P201	JD01		1	00D2051254007	XLR IN (JY-5033U)	JY-5033U*030
P201	JD02		1	00MYT02021220	YKC21-3248V 14X14 RA 2L2P BLK NI FLM-GND	RCA2P(BLK/BLK)
P201	JD03		1	00D2051255006	XLR OUT (JY-5032A)	JY-5032A*030
P201	JD06		1	00MYJ07014260	20FMN-BMTTN-A-TFT	
P201	JD07		1	00MYJ07014280	22FMN-BMTTN-TFT JST	22FMN-BMTTN-TFT JST
P201	LA01		1	00MFC90020110	BLM18BD601SN1D	
P201	LA02		1	00MFC90020110	BLM18BD601SN1D	
P201	LA03		1	00MFC90020110	BLM18BD601SN1D	
P201	LA04		1	00MFC90020110	BLM18BD601SN1D	
P201	LA05		1	00MNN05102610	1kΩ ±5% 1/16W	1K OHM 1/16W +- 5%
P201	LA06		1	00MNN05102610	1kΩ ±5% 1/16W	1K OHM 1/16W +- 5%
P201	LB01		1	00MFC90020110	BLM18BD601SN1D	
P201	LB02		1	00MFC90020110	BLM18BD601SN1D	
P201	LB03		1	00MFC90020110	BLM18BD601SN1D	
P201	LB04		1	00MFC90020110	BLM18BD601SN1D	
P201	LB05		1	00MFC90020110	BLM18BD601SN1D	
P201	LB06		1	00MFC90020110	BLM18BD601SN1D	
P201	LB07		1	00MFC90020110	BLM18BD601SN1D	
P201	LB08		1	00MFC90020110	BLM18BD601SN1D	
P201	LB09		1	00D2140127003	RELAY(RY-12W)	
P201	LB10		1	00D2140127003	RELAY(RY-12W)	
P201	LB11		1	00MFN31010030	BLM18B102SN1D	BLM11B102S 1608 EMIFILTER
P201	LB12		1	00MFN31010030	BLM18B102SN1D	BLM11B102S 1608 EMIFILTER
P201	LB13		1	00MFN31010030	BLM18B102SN1D	BLM11B102S 1608 EMIFILTER
P201	LC01		1	00MFN21020040	DLP11SN161SL2 COMMON MODE CHOKE COILS	
P201	LC02		1	00MFN21020040	DLP11SN161SL2 COMMON MODE CHOKE COILS	
P201	LC03		1	00MFC90020110	BLM18BD601SN1D	
P201	LC04		1	00MFC90020110	BLM18BD601SN1D	
P201	LD01		1	00MTP41042010	PULS TRANS FOR CD	PULS TRANS FOR CD

NOTE : \*nsp\* PART IS LISTED FOR REFERENCE ONLY, MARANTZ WILL NOT SUPPLY THESE PARTS.

PWB NAME	POS. NO.	VERS. COLOR	QTY	PART NO.	PART NAME	DESCRIPTION
P201	LD02		1	00MFN31010030	BLM18B102SN1D	BLM11B102S 1608 EMIFILTER
P201	LD03		1	00MFN31010030	BLM18B102SN1D	BLM11B102S 1608 EMIFILTER
P201	LD06		1	00MTP41042010	PULS TRANS FOR CD	PULS TRANS FOR CD
P201	QA01		1	00D2730414906	2SC3326(A/B) +C	
P201	QA02		1	00D2730414906	2SC3326(A/B) +C	
P201	QA03		1	00D2730414906	2SC3326(A/B) +C	
P201	QA04		1	00D2730414906	2SC3326(A/B) +C	
P201	QA05		1	00D2631071901	OPA2134UA +C	OPA2134UA
P201	QA06		1	00D2631071901	OPA2134UA +C	OPA2134UA
P201	QA07		1	00MHC10137370	NE5532DR TEXAS INSTRUMENTS	NE5532DR
P201	QA08		1	00MHC10137370	NE5532DR TEXAS INSTRUMENTS	NE5532DR
P201	QA09		1	00MHC10308030	LC78211	LC78211
P201	QA10		1	00MHC10137370	NE5532DR TEXAS INSTRUMENTS	NE5532DR
P201	QA11		1	00MHC10486050	TC9459BFG-EL	
P201	QA12		1	00MHC10137370	NE5532DR TEXAS INSTRUMENTS	
P201	QA13		1	00MHC10137370	NE5532DR TEXAS INSTRUMENTS	
P201	QA15		1	00MHC12252090	NJM2387DL2	
P201	QA16		1	00MHC10137370	NE5532DR TEXAS INSTRUMENTS	NE5532DR
P201	QA17		1	00MHC10137370	NE5532DR TEXAS INSTRUMENTS	NE5532DR
P201	QA18		1	00MHX300012B0	2SC4081(R.S) 2SC4116(GR.BL)	
P201	QA19		1	00MHX300012B0	2SC4081(R.S) 2SC4116(GR.BL)	
P201	QA20		1	00MHX341161C0	2SC4116GR	
P201	QA21		1	00MHX300012B0	2SC4081(R.S) 2SC4116(GR.BL)	
P201	QA22		1	00MBA21111000	DTC114TE,RN1111	DTC114TE,RN1111
P201	QA23		1	00MBA21111000	DTC114TE,RN1111	DTC114TE,RN1111
P201	QA24		1	00MBA21111000	DTC114TE,RN1111	DTC114TE,RN1111
P201	QA25		1	00MBA21111000	DTC114TE,RN1111	DTC114TE,RN1111
P201	QA26		1	00MBA20021210	DTC144EC (ROHM)	
P201	QA27		1	00MBA20021210	DTC144EC (ROHM)	
P201	QA28		1	00MBA12111000	DTA114TE /RN2111	DTA114TE /RN2111
P201	QA30		1	00MBA12111000	DTA114TE /RN2111	DTA114TE /RN2111
P201	QA31		1	00MBA21111000	DTC114TE,RN1111	DTC114TE,RN1111
P201	QA32		1	00MBA21111000	DTC114TE,RN1111	DTC114TE,RN1111
P201	QA33		1	00MBA21111000	DTC114TE,RN1111	DTC114TE,RN1111
P201	QA34		1	00MBA21111000	DTC114TE,RN1111	DTC114TE,RN1111
P201	QB01		1	00MHX341161C0	2SC4116GR	
P201	QB02		1	00MHX341161C0	2SC4116GR	
P201	QB03		1	00MHC10137370	NE5532DR TEXAS INSTRUMENTS	
P201	QB04		1	00MHC10137370	NE5532DR TEXAS INSTRUMENTS	
P201	QB05		1	00D2730414906	2SC3326(A/B) +C	
P201	QB06		1	00D2730414906	2SC3326(A/B) +C	
P201	QB07		1	00D2730414906	2SC3326(A/B) +C	
P201	QB08		1	00D2730414906	2SC3326(A/B) +C	
P201	QB09		1	00MHC10137370	NE5532DR TEXAS INSTRUMENTS	
P201	QB10		1	00D2730414906	2SC3326(A/B) +C	
P201	QB11		1	00MHC10137370	NE5532DR TEXAS INSTRUMENTS	NE5532DR
P201	QB12		1	00MHC10486050	TC9459BFG-EL	
P201	QB14		1	00D2631071901	OPA2134UA +C	OPA2134UA
P201	QB15		1	00MHC10137370	NE5532DR TEXAS INSTRUMENTS	
P201	QD01		1	00D2623125904	SN65LVDS179DGK-EL2 +REF	
P201	QD02		1	00MHC700400Z0	CMOS 74HCU04 FLAT TAPING	
P201	QD03		1	00MHC10022370	SN65LVD3487D	
P201	QD04		1	00MHC10019880	CS8420-CSZR	
P201	QD05		1	00MHC12271990	CS4271-CZZR CODEC	
P201	QD06		1	00D2622785905	SN74LV125APWRG4 +C	

NOTE : "nsp" PART IS LISTED FOR REFERENCE ONLY, MARANTZ WILL NOT SUPPLY THESE PARTS.

PWB NAME	POS. NO.	VERS. COLOR	QTY	PART NO.	PART NAME	DESCRIPTION
P201	QD07		1	00D2622515900	SN74LV04APW-EL2 +C	
P201	QD08		1	00D2622785905	SN74LV125APWRG4 +C	
P201	RB85		1	00MNI05000110	0Ω ±5% 1/10W	
P201	RB86		1	00MNI05000110	0Ω ±5% 1/10W	
P201	RC50		1	00MNI05000110	0Ω ±5% 1/10W	
P201	RC51		1	00MNI05000110	0Ω ±5% 1/10W	
P201	RC52		1	00MNI05000110	0Ω ±5% 1/10W	
P201	RC53		1	00MNI05000110	0Ω ±5% 1/10W	
P201	RC54		1	00MNI05000110	0Ω ±5% 1/10W	
P201	RC61		1	00MNI05000110	0Ω ±5% 1/10W	
P201	RD40		1	00MNI05000110	0Ω ±5% 1/10W	
P201	RD41		1	00MDK98105200	1UF 10V F	1UF 10VDC 1608
P201	RD83		1	00MNI05000110	0Ω ±5% 1/10W	
P201	RD87		1	00MNI05000110	0Ω ±5% 1/10W	
P201	RD89		1	00MNI05000110	0Ω ±5% 1/10W	
P201	RZ01		1	00MNI05000110	0Ω ±5% 1/10W	0 Ω 1/10W ± 5%
P201	RZ02		1	00MNI05000110	0Ω ±5% 1/10W	0 Ω 1/10W ± 5%
P201	RZ03		1	00MRI05000180	0Ω ±5% 1/8W	0 Ω 1/8W ± 5%
P201	RZ04		1	00MRI05000180	0Ω ±5% 1/8W	0 Ω 1/8W ± 5%
P201	RZ05		1	00MRI05000180	0Ω ±5% 1/8W	0 Ω 1/8W ± 5%
P201	RZ06		1	00MNI05000110	0Ω ±5% 1/10W	0 Ω 1/10W ± 5%
P201	RZ07		1	00MRI05000180	0Ω ±5% 1/8W	0 Ω 1/8W ± 5%
P201	RZ08		1	00MRI05000180	0Ω ±5% 1/8W	0 Ω 1/8W ± 5%
P201	RZ09		1	00MNI05000110	0Ω ±5% 1/10W	0 Ω 1/10W ± 5%
P201	RZ14		1	00MNI05000110	0Ω ±5% 1/10W	0 Ω 1/10W ± 5%
P201	RZ16		1	00MNI05000110	0Ω ±5% 1/10W	0 Ω 1/10W ± 5%
P201	RZ18		1	00MRI05000180	0Ω ±5% 1/8W	0 Ω 1/8W ± 5%
P201	RZ19		1	00MRI05000180	0Ω ±5% 1/8W	0 Ω 1/8W ± 5%
P201	RZ20		1	00MNI05000110	0Ω ±5% 1/10W	0 Ω 1/10W ± 5%
P201	RZ21		1	00MRI05000180	0Ω ±5% 1/8W	0 Ω 1/8W ± 5%
P201	RZ22		1	00MRI05000180	0Ω ±5% 1/8W	0 Ω 1/8W ± 5%
P201	RZ23		1	00MNI05000110	0Ω ±5% 1/10W	0 Ω 1/10W ± 5%
P201	RZ24		1	00MNI05000110	0Ω ±5% 1/10W	0 Ω 1/10W ± 5%
P201	RZ25		1	00MNI05000110	0Ω ±5% 1/10W	0 Ω 1/10W ± 5%
P201	RZ26		1	00MRI05000180	0Ω ±5% 1/8W	0 Ω 1/8W ± 5%
P201	RZ27		1	00MNI05000110	0Ω ±5% 1/10W	0 Ω 1/10W ± 5%
P201	RZ28		1	00MNI05000110	0Ω ±5% 1/10W	0 Ω 1/10W ± 5%
P201	RZ29		1	00MNI05000110	0Ω ±5% 1/10W	0 Ω 1/10W ± 5%
P201	RZ30		1	00MNI05000110	0Ω ±5% 1/10W	0 Ω 1/10W ± 5%
P201	RZ31		1	00MRI05000180	0Ω ±5% 1/8W	0 Ω 1/8W ± 5%
P201	RZ32		1	00MRI05000180	0Ω ±5% 1/8W	0 Ω 1/8W ± 5%
P201	RZ33		1	00MNI05000110	0Ω ±5% 1/10W	0 Ω 1/10W ± 5%
P201	RZ34		1	00MNI05000110	0Ω ±5% 1/10W	0 Ω 1/10W ± 5%
P201	RZ35		1	00MNI05000110	0Ω ±5% 1/10W	0 Ω 1/10W ± 5%
P201	RZ36		1	00MNI05000110	0Ω ±5% 1/10W	0 Ω 1/10W ± 5%
P201	RZ37		1	00MNI05000110	0Ω ±5% 1/10W	0 Ω 1/10W ± 5%
P201	RZ38		1	00MNI05000110	0Ω ±5% 1/10W	0 Ω 1/10W ± 5%
P201	RZ39		1	00MNI05000110	0Ω ±5% 1/10W	0 Ω 1/10W ± 5%
P201	RZ40		1	00MNI05000110	0Ω ±5% 1/10W	0 Ω 1/10W ± 5%
P201	RZ41		1	00MRH05103010	0.01Ω ±5% 1W SL1	0.01 Ω ± 5% 1W SL1
P201	RZ42		1	00MNI05000110	0Ω ±5% 1/10W	0 Ω 1/10W ± 5%
P201	RZ43		1	00MNI05000110	0Ω ±5% 1/10W	0 Ω 1/10W ± 5%
P201	RZ44		1	00MNI05000110	0Ω ±5% 1/10W	0 Ω 1/10W ± 5%

NOTE : \*nsp\* PART IS LISTED FOR REFERENCE ONLY, MARANTZ WILL NOT SUPPLY THESE PARTS.

PWB NAME	POS. NO.	VERS. COLOR	QTY	PART NO.	PART NAME	DESCRIPTION
	5202			nsp	<b>FRONT PCB ASSY</b>	
P202	D850		1	00MHI10124210	SML-512MW	
P202	D851		1	00MHI10124210	SML-512MW	
P202	D852		1	00MHI10124210	SML-512MW	
P202	D853		1	00MHI10124210	SML-512MW	
P202	D854		1	00MHI10124210	SML-512MW	
P202	D855		1	00MHI10124210	SML-512MW	
P202	D856		1	00MHI10124210	SML-512MW	
P202	D857		1	00MHI10124210	SML-512MW	
P202	D858		1	00MHI10123210	SML-512DW	
P202	D859		1	00MHI10123210	SML-512DW	
P202	D860		1	00MHI10123210	SML-512DW	
P202	D861		1	00MHI10123210	SML-512DW	
P202	D862		1	00MHI10116210	SML-512UW RED LED	SML-512UW RED LED
P202	D863		1	00MHI10124210	SML-512MW	
P202	D864		1	00MHI10124210	SML-512MW	
P202	D865		1	00MHI10124210	SML-512MW	
P202	D866		1	00MHI10124210	SML-512MW	
P202	D867		1	00MHI10124210	SML-512MW	
P202	D868		1	00MHI10124210	SML-512MW	
P202	D869		1	00MHI10124210	SML-512MW	
P202	D870		1	00MHI10124210	SML-512MW	
P202	D871		1	00MHI10124210	SML-512MW	
P202	D872		1	00MHI10124210	SML-512MW	
P202	D873		1	00MHI10124210	SML-512MW	
P202	D874		1	00MHI10123210	SML-512DW	
P202	D875		1	00MHI10123210	SML-512DW	
P202	D876		1	00MHI10123210	SML-512DW	
P202	D877		1	00MHI10123210	SML-512DW	
P202	D878		1	00MHI10116210	SML-512UW RED LED	SML-512UW RED LED
P202	D879		1	00MHI10116210	SML-512UW RED LED	SML-512UW RED LED
P202	D880		1	00MHI10116210	SML-512UW RED LED	SML-512UW RED LED
P202	D881		1	00MHI10116210	SML-512UW RED LED	SML-512UW RED LED
P202	D882		1	00MHI10116210	SML-512UW RED LED	SML-512UW RED LED
P202	D883		1	00D2760833900	ESD PROTECTOR(6802)	
P202	J850		1	00MYJ07027360	IMSA-9631S-34	
P202	J851		1	00MYB00067530	PHR5/JB20-05HG UL1571 AWG28 CONNECTIVE W	
P202	J852		1	00MYJ07061740	IMSA-9616S-14Y903 FFC ZIFCONNECTOR P=1.0	
P202	Q852		1	00MHC10244090	NJU3716AM-TE1	
P202	Q853		1	00MHC10244090	NJU3716AM-TE1	
P202	S850		1	00MSP01013830	SKPMAPE010 KPM-901	
P202	S851		1	00MSP01013830	SKPMAPE010 KPM-901	
P202	S852		1	00MSP01013830	SKPMAPE010 KPM-901	
P202	S858		1	00MSP01013320	TACT SWITCH SKHMPW	
P202	S860		1	00MSP01013830	SKPMAPE010 KPM-901	
P202	S861		1	00MSM01013300	SPPW810400 SENSOR TYPE MINI PUSH SWITCH	
P202	S862		1	00MSP01013320	TACT SWITCH SKHMPW	
P202	S863		1	00MSP01013320	TACT SWITCH SKHMPW	
	5203			nsp	<b>RS232C INTERFACE PCB ASSY</b>	
P203	C500		1	00MOA47505020	4.7µF M 50V RA-2	
P203	C502		1	00MOA47505020	4.7µF M 50V RA-2	
P203	C508		1	00MOA47505020	4.7µF M 50V RA-2	

NOTE : "nsp" PART IS LISTED FOR REFERENCE ONLY, MARANTZ WILL NOT SUPPLY THESE PARTS.



PWB NAME	POS. NO.	VERS. COLOR	QTY	PART NO.	PART NAME	DESCRIPTION
P203	C510		1	00MOA47505020	4.7µF M 50V RA-2	
P203	C512		1	00MOA47505020	4.7µF M 50V RA-2	
P203	C514		1	00MOA47505020	4.7µF M 50V RA-2	
P203	C516		1	00MOA47505020	4.7µF M 50V RA-2	
P203	C521		1	00MOA10601620	10µF M 16V RA-2	
P203	D500		1	00D3939631903	TLGU1002A(T02)	
P203	J501		1	00MYJ07014130	7P FFC CONNECTOR FMN-BMTTN -TD	7P FFC CONNECTOR FMN-BMTTN -TD
P203	J502		1	00MYJ07019770	B7B-PH-SM4-TB (LF)(SN)	B7B-PH-SM3-TB
P203	J503		1	00D2051243005	9P DSUB KIT	
P203	L500		1	00MFC90020110	BLM18BD601SN1D	BLM11B601
P203	L501		1	00MFC90020110	BLM18BD601SN1D	BLM11B601
P203	L502		1	00MFC90020110	BLM18BD601SN1D	BLM11B601
P203	L503		1	00MFC90020110	BLM18BD601SN1D	BLM11B601
P203	Q500		1	00MHC10292060	UPD4721GS-GJG IC RS232C	
P203	Q501		1	00D2622785905	SN74LV125APWRG4 +C	
	5204			nsp	<b>ENCODER PCB ASSY</b>	
P204	J970		1	00MYJ06006450	S5B-PH-K-S (LF)(SN)	S5B-PH-K-S
P204	S970		1	00MSR01030150	EC11B15242AE	EC11B15242AE ENCODER
	5205			nsp	<b>STANDBY LED PCB ASSY</b>	
P205	D980		1	00MH10127210	SML312BC4TT86	
P205	W980		1	00MYB00183300	PHR2/JB20-02HG UL1571 AWG28 CONNECTIVE W	
	5300			nsp	<b>POWER &amp; HP/PARALLEL PWB ASSY</b>	
	5301			nsp	<b>POWER PCB ASSY</b>	
P301	▲ C701		1	00MDF17224570	# ECQU2A224ML 0.22µF/250V	#DE1E3KX152MB4BL01
P301	▲ C702		1	00MDK17471527	DE0910 B 471K -KX 470PF 250V	#DE0910 B 471K -KX 470PF 250V
P301	▲ C703		1	00MDK17471527	DE0910 B 471K -KX 470PF 250V	#DE0910 B 471K -KX 470PF 250V
P301	▲ C704		1	00MEA12740090	! 120µF 400V SIDE-TYPE	
P301	▲ C705		1	00MDK17681527	#DE1B3KX681KB5B	
P301	C707		1	00MOA47602520	47µF M 25V RA-2	
P301	C708		1	00MDK48474200	0.47µF 50V GRM42-6 F 474Z50PT	0.47µF 50V GRM42-6 F 474Z50PT
P301	C709		1	00MDK48474200	0.47µF 50V GRM42-6 F 474Z50PT	0.47µF 50V GRM42-6 F 474Z50PT
P301	▲ C710		1	00MDK17471527	DE0910 B 471K -KX 470PF 250V	DE0910 B 471K -KX 470PF 250V
P301	C712		1	00MOA47603520	47µF M 35V RA-2	
P301	C715		1	00MEF56703526	RJH-35V561MI5#-S1	
P301	C719		1	00MOA10701620	100µF M 16V RA-2	
P301	C720		1	00MOA10605020	10µF M 50V RA-2	
P301	C723		1	00MOA10701620	100µF M 16V RA-2	
P301	C724		1	00MEF68703516	RJH-35V681MI6#-S1	
P301	C728		1	00MEF68703516	RJH-35V681MI6#-S1	
P301	C736		1	00MOA33602520	33µF M 25V RA-2	
P301	C741		1	00MEF56703526	RJH-35V561MI5#-S1	
P301	C743		1	00MOA10602520	10µF M 25V RA-2	
P301	C744		1	00MEF56703526	RJH-35V561MI5#-S1	
P301	C746		1	00MOA10602520	10µF M 25V RA-2	

NOTE : "nsp" PART IS LISTED FOR REFERENCE ONLY, MARANTZ WILL NOT SUPPLY THESE PARTS.

PWB NAME	POS. NO.	VERS. COLOR	QTY	PART NO.	PART NAME	DESCRIPTION
P301	C747		1	00MOA10701620	100µF M 16V RA-2	
P301	▲ C755		1	00MDF17224570	# ECQU2A224ML 0.22µF/250V	#DE1E3KX152MB4BL01
P301	▲ D700		1	00MHD20031290	S1WB(A)60 30A 600V	S1WB(A)60 30A 600V
P301	▲ D701		1	00MHV00001290	ST03D-170 TRANKILLER	ST03D-170 TRANKILLER
P301	▲ D702		1	00MHE10010080	!FMB26L	
P301	D703		1	00D2760560901	DAN202KT146 +C	DAN202K ROHM
P301	▲ D705		1	00D2623047008	PC123Y22	PC-123Y22 PHOTO CUPLER
P301	D706	/N1S		251010002108P	ERZV09D270	
P301	D709		1	00D2760559909	DAP202KT146 +C	
P301	D710		1	00D2760683943	UDZS3.6B-TE17	
P301	D711		1	00D2760560901	DAN202KT146 +C	DAN202K ROHM
P301	D712		1	00D2760684900	RB051L-40TE25 +C	
P301	D715		1	00D2760684900	RB051L-40TE25 +C	
P301	D717		1	00D2760684900	RB051L-40TE25 +C	
P301	D720		1	00MHW10036320	GP1S58V PHOTE INTERLUPTER	
P301	▲ F700	/F1S	1	00D2061035067	FUSE(2.5A)T(A)MINI	
P301	▲ F700	/N1S	1	00D2061089013	#FUSE (ET1.25A)	
P301	▲ F700	/U1S	1	00D2061039076	#FUSE 2.5A	
P301	▲ G700		1	00MHV00033020	#ERZV07D471	# ERZV07D471
P301	▲ J701		1	00D2050581001	2P VH CON BASE (White)	CONNECTOR 2P B3P-VH
P301	J702		1	00MYJ07019780	B8B-PH-SM4-TB (LF)(SN)	B8B-PH-SM3-TB JST
P301	J703		1	00MYJ07019720	B2B-PH-SM4-TB (LF)(SN)	B2B-PH-SM3-TB JST
P301	J704		1	00MYJ07014130	7P FFC CONNECTOR FMN-BMTTN -TD	7P FFC CONNECTOR FMN-BMTTN -TD
P301	J705		1	00MYL01010240	GND TERMINAL FOR PCB	EARTH LUG
P301	J707		1	00MYL01010240	GND TERMINAL FOR PCB	EARTH LUG
P301	J708		1	00D2020040909	FUSE CLIP(TAPE)	FUSE CLIP
P301	J709		1	00D2020040909	FUSE CLIP(TAPE)	FUSE CLIP
P301	J710		1	00MYP06010450	B5B-EH-TS (LF)(SN) 5P RADIAL TAPING	B5B-EH 5P RADIAL TAPING
P301	▲ L700		1	00MLC25060010	LF-4Z-E503H	# LF-4Z-E503H
P301	L701		1	00MLU80333070	CDRH8D43-330NC	CDRH8D43-330NC
P301	L702		1	00MLC11040190	100UH COM.MODE COIL	100UH COM.MODE COIL
P301	L703		1	00D2140195006	RELAY FTR-F1	
P301	L704		1	00MLU80563010	CDRH127/LDNP-560MC	
P301	L705		1	00MLU80683020	CDRH8D43-680NC	
P301	L706		1	00MLU12103010	NL322522-100J	NL322522-100K
P301	L707		1	00MLU80683020	CDRH8D43-680NC	
P301	L708		1	00MLU12103010	NL322522-100J	NL322522-100K
P301	Q700		1	00MHC10180020	MIP3E50MY	
P301	Q701		1	00MHC33036590	TL431CZ PROG.VOLTAGE REFERENCE	
P301	Q702		1	00D2690082902	DTC114EKT96 +C	
P301	Q703		1	00MHC12252090	NJM2387DL2	
P301	Q704		1	00D2623506905	BD9781HFP-TR	
P301	Q705		1	00D2690082902	DTC114EKT96 +C	
P301	Q706		1	00D2690082902	DTC114EKT96 +C	
P301	Q707		1	00D2690082902	DTC114EKT96 +C	
P301	Q708		1	00MHX341161C0	2SC4116GR	
P301	Q709		1	00MHS43BSN01F	UPD78F9222(DNC640)	
P301	Q710		1	00D2690082902	DTC114EKT96 +C	
P301	Q711		1	00D2690082902	DTC114EKT96 +C	
P301	Q712		1	00D2622785905	SN74LV125APWRG4 +C	

NOTE : "nsp" PART IS LISTED FOR REFERENCE ONLY, MARANTZ WILL NOT SUPPLY THESE PARTS.

PWB NAME	POS. NO.	VERS. COLOR	QTY	PART NO.	PART NAME	DESCRIPTION
P301	Q713		1	00D2690083901	DTA114EKT96 +C	
P301	Q714		1	00D2690082902	DTC114EKT96 +C	
P301	Q715		1	00MHC10226210	BA9741FS-E2 2CH DC/DC	
P301	Q716		1	00MHX117971A0	2SA1797	2SA1797
P301	Q717		1	00MHX117971A0	2SA1797	2SA1797
P301	Q718		1	00MHX346721A0	2SC4672 Q	2SC4672 Q
P301	Q719		1	00D2680077901	ICP-N50T	
P301	Q720		1	00D2690082902	DTC114EKT96 +C	
P301	R700		1	00MRC05105012	1M $\Omega$ $\pm$ 5% 1W RCR60 L15	1M $\Omega$ $\pm$ 5% 1W RCR60 L15
P301	R703		1	00MRI05150140	15 $\Omega$ $\pm$ 5% 1/4W	15 $\Omega$ $\pm$ 5% 1/4W
P301	R704	/F1S		00MNN05150610		
P301	R704	/N1S		00MNN05561610		
P301	R704	/U1S		00MNN05150610		
P301	R711		1	00MRI05330120	33 $\Omega$ $\pm$ 5% 1/2W	33 $\Omega$ $\pm$ 5% 1/2W
P301	R722		1	00MNI05000110	0 $\Omega$ $\pm$ 5% 1/10W	
P301	R723		1	00MNI05000110	0 $\Omega$ $\pm$ 5% 1/10W	
P301	R724		1	00MNN05000610	0 $\Omega$ $\pm$ 5% 1/16W	
P301	R726		1	00MNI05000110	0 $\Omega$ $\pm$ 5% 1/10W	
P301	R727		1	00MNI05000110	0 $\Omega$ $\pm$ 5% 1/10W	
P301	R831		1	00MFC90090010	ZBF503D-00(TA)-01	ZBF503D-00(TA)-01
P301	R993	/F1S		00MNI05000110	0 $\Omega$ $\pm$ 5% 1/10W	
P301	R993	/N1S	1	00MNI05561110	560 $\Omega$ $\pm$ 5% 1/10W	
P301	R993	/U1S	1	00MNI05000110	0 $\Omega$ $\pm$ 5% 1/10W	
P301	S700		1	00MSP01013820	SDKLA1-BP1 TV5 250V 5A	1SDKLA10200
P301	T700		1	00MTS12900110	#ER SW TRANS	
P301	X700		1	00D3990796900	X'TAL(10MHZ/SMT) +REF	
	5302			nsp	<b>HEAD PHONES PCB ASSY</b>	
P302	C801		1	00MOA47602520	47 $\mu$ F M 25V RA-2	
P302	C802		1	00MOA47602520	47 $\mu$ F M 25V RA-2	
P302	C803		1	00MEG47601650	47 $\mu$ F/ 16V	47 $\mu$ F 16V
P302	C804		1	00MEG47601650	47 $\mu$ F/ 16V	47 $\mu$ F 16V
P302	C809		1	00MOA22701620	220 $\mu$ F M 16V RA-2	
P302	C810		1	00MOA22701620	220 $\mu$ F M 16V RA-2	
P302	C813		1	00MDK96222300	2200PF (GR39)	
P302	D801		1	00D2760560901	DAN202KT146 +C	DAN202K ROHM
P302	D802		1	00D2760559909	DAP202KT146 +C	DAP202K
P302	J800		1	00D2050863994	6P PH CON.BASE(L) +REF	
P302	J801		1	00MYJ01080220	YKB21-5265 6.3mm STREO PHONE JACK	
P302	L803		1	00MFN31010030	BLM18B102SN1D	BLM11B102S 1608 EMIFILTER
P302	L804		1	00MFN31010030	BLM18B102SN1D	BLM11B102S 1608 EMIFILTER
P302	L806		1	00D2350147909	E.FIL(BLM21PG221SN1)+2125	
P302	L807		1	00D2350147909	E.FIL(BLM21PG221SN1)+2125	
P302	L808		1	00MFN31010030	BLM18B102SN1D	BLM11B102S 1608 EMIFILTER
P302	L810		1	00MFN31010030	BLM18B102SN1D	BLM11B102S 1608 EMIFILTER
P302	L811		1	00MFN31010030	BLM18B102SN1D	BLM11B102S 1608 EMIFILTER
P302	Q801		1	00MHC10045090	NJM4556AM-TE1	
P302	Q802		1	00D2730414906	2SC3326(A/B) +C	
P302	Q803		1	00D2730414906	2SC3326(A/B) +C	

NOTE : "nsp" PART IS LISTED FOR REFERENCE ONLY, MARANTZ WILL NOT SUPPLY THESE PARTS.

PWB NAME	POS. NO.	VERS. COLOR	QTY	PART NO.	PART NAME	DESCRIPTION
P302	Q804		1	00D2730414906	2SC3326(A/B) +C	
P302	Q805		1	00D2730414906	2SC3326(A/B) +C	
P302	R802		1	00MRM01031250	RK0971220 10K A (D-CUT REV)	RK0971220 10K A (D-CUT REV)
	5303			nsp	<b>PARALLEL IO PCB ASSY</b>	
P303	C650		1	00MOA10701620	100µF M 16V RA-2	
P303	C651		1	00MDK98104200	GRM39F104Z16 0.1UF MURATA	
P303	C652		1	00MOA10701620	100µF M 16V RA-2	
P303	D655		1	00D2760560901	DAN202KT146 +C	DAN202K ROHM
P303	D656		1	00D2760560901	DAN202KT146 +C	DAN202K ROHM
P303	D657		1	00D2760560901	DAN202KT146 +C	DAN202K ROHM
P303	D658		1	00D2760560901	DAN202KT146 +C	DAN202K ROHM
P303	D659		1	00D2760559909	DAP202KT146 +C	DAP202K
P303	D660		1	00D2760559909	DAP202KT146 +C	DAP202K
P303	D661		1	00D2760559909	DAP202KT146 +C	DAP202K
P303	D662		1	00D2760559909	DAP202KT146 +C	DAP202K
P303	J651		1	00MYJ90001550	YKF42-8524N	
P303	J652		1	00MYJ07014200	14P FFC CONNECTOR FMN-BMTTN-TP	

NOTE : "nsp" PART IS LISTED FOR REFERENCE ONLY, MARANTZ WILL NOT SUPPLY THESE PARTS.