

# Service Manual

PMD650 /N1B, /U1B, /F1B

## Portable Mini Disc Recorder

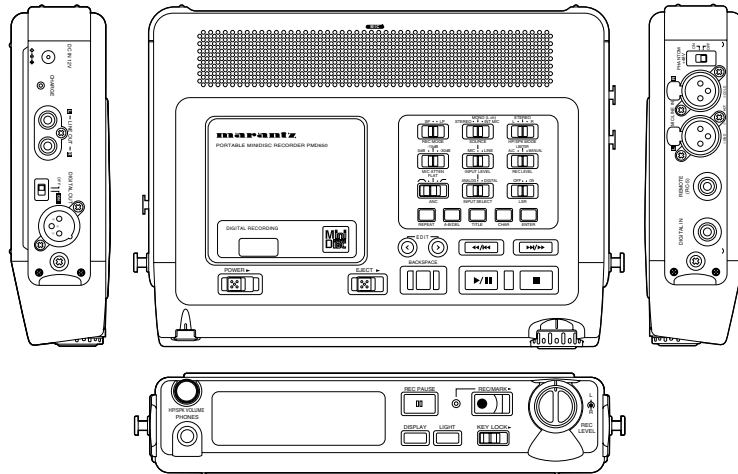

PMD650

### TABLE OF CONTENTS

SECTION	PAGE
1. TECHNICAL SPECIFICATIONS .....	1
2. SERVICE MODE .....	2
3. MD MODULE(KML-252 with PCB) ELECTRICAL ADJUSTMENTS .....	4
4. LCD CONTRAST ADJUSTMENT .....	11
5. HOW TO DISASSEMBLE .....	11
6. WAVEFORMS .....	17
7. BUGS AND PROBLEMS .....	18
8. WIRING DIAGRAM .....	19
9. BLOCK DIAGRAM .....	21
10. LEVEL DIAGRAM .....	23
11. SCHEMATIC DIAGRAM.....	25
12. PARTS LOCATIONS .....	45
13. MICROPROCESSOR AND IC DATA .....	53
14. EXPLODED VIEW AND MECHANISM PARTS LIST.....	57
15. ELECTRICAL PARTS LIST .....	59

Please use this service manual with referring to the user guide ( D.F.U. ) without fail.

修理の際は、必ず取扱説明書を準備し操作方法を確認の上作業を行ってください。

# marantz®

## PMD650

## MARANTZ DESIGN AND SERVICE

Using superior design and selected high grade components, **MARANTZ** company has created the ultimate in stereo sound. Only original **MARANTZ** parts can insure that your **MARANTZ** product will continue to perform to the specifications for which it is famous.

Parts for your **MARANTZ** equipment are generally available to our National Marantz Subsidiary or Agent.

### ORDERING PARTS :

Parts can be ordered either by mail or by Fax.. In both cases, the correct part number has to be specified.

The following information must be supplied to eliminate delays in processing your order :

1. Complete address
2. Complete part numbers and quantities required
3. Description of parts
4. Model number for which part is required
5. Way of shipment
6. Signature : any order form or Fax. must be signed, otherwise such part order will be considered as null and void.

#### USA

**MARANTZ AMERICA, INC.**  
440 MEDINAH ROAD  
ROSELLE, ILLINOIS 60172  
USA  
PHONE : 630 - 307 - 3100  
FAX : 630 - 307 - 2687

#### EUROPE / TRADING

**MARANTZ EUROPE B.V.**  
P.O.BOX 80002, BUILDING SFF2  
5600 JB EINDHOVEN  
THE NETHERLANDS  
PHONE : +31 - 40 - 2732241  
FAX : +31 - 40 - 2735578

#### BRAZIL

**PHILIP DA AMAZONIA IND. ELET. ITDA**  
CENTRO DE INFORMACOES AO  
CEP 04698-970  
SAO PAULO, SP, BRAZIL  
PHONE : 0800 - 123123(Discagem Direta Gratuita)  
FAX : +55 11 534. 8988

#### **PROFESSIONAL AMERICAS** **SUPERSCOPE TECHNOLOGIES, INC.**

MARANTZ PROFESSIONAL PRODUCTS  
2640 WHITE OAK CIRCLE, SUITE A  
AURORA, ILLINOIS 60504 USA  
PHONE : 630 - 820 - 4800  
FAX : 630 - 820 - 8103

#### **PROFESSIONAL AUSTRALIA** **TECHNICAL AUDIO GROUP PTY, LTD**

558 DARLING STREET,  
BALMAIN, NSW 2041,  
AUSTRALIA  
PHONE : 61 - 2 - 9810 - 5300  
FAX : 61 - 2 - 9810 - 5355

#### CANADA

**LENBROOK INDUSTRIES LIMITED**  
633 GRANITE COURT,  
PICKERING, ONTARIO L1W 3K1  
CANADA  
PHONE : 905 - 831 - 6333  
FAX : 905 - 831 - 6936

#### AUSTRALIA

**JAMO AUSTRALIA PTY LTD**  
1 EXPO COURT, P.O. BOX 350  
MT. WAVERLEY VIC 3149  
AUSTRALIA  
PHONE : +61 - 3 - 9543 - 1522  
FAX : +61 - 3 - 9543 - 3677

#### THAILAND

**MRZ STANDARD CO.,LTD**  
746 - 754 MAHACHAI ROAD.,  
WANGBURAPAPIROM, PHRANAKORN,  
BANGKOK, 10200 THAILAND  
PHONE : +66 - 2 - 222 9181  
FAX : +66 - 2 - 224 6795

#### SINGAPORE

**WO KEE HONG (S) PTE LTD**  
WO KEE HONG CENTRE  
NO.23, LORONG 8, TOA PAYOH  
SINGAPORE 319257  
PHONE : +65 2544555  
FAX : +65 2502213

#### NEW ZEALAND

**WILDASH AUDIO SYSTEMS NZ**  
14 MALVERN ROAD MT ALBERT  
AUCKLAND NEW ZEALAND  
PHONE : +64 - 9 - 8451958  
FAX : +64 - 9 - 8463554

#### TAIWAN

**PAI- YUING CO., LTD.**  
6 TH FL NO, 148 SUNG KIANG ROAD,  
TAIPEI, 10429, TAIWAN R.O.C.  
PHONE : +886 - 2 - 25221304  
FAX : +886 - 2 - 25630415

#### MALAYSIA

**WO KEE HONG ELECTRONICS SDN. BHD.**  
SUITE 8.1, LEVEL 8, MENARA GENESIS,  
NO. 33, JALAN SULTAN ISMAIL,  
50250 KUALA LUMPUR, MALAYSIA  
PHONE : +60 3 - 2457677  
FAX : +60 3 - 2458180

#### JAPAN *Technical*

**MARANTZ JAPAN, INC.**  
35- 1, 7- CHOME, SAGAMIONO  
SAGAMIHARA - SHI, KANAGAWA  
JAPAN 228-8505  
PHONE : +81 42 748 1013  
FAX : +81 42 741 9190

#### 日本マランツ株式会社

本社 〒228-8505  
神奈川県相模原市相模大野7-35-1  
営業本部 〒150-0022  
東京都渋谷区恵比寿南1-11-9

#### KOREA

**MK ENTERPRISES LTD.**  
ROOM 604/605, ELECTRO-OFFICETEL, 16-58,  
3GA, HANGANG-RO, YONGSAN-KU, SEOUL  
KOREA  
PHONE : +822 - 3232 - 155  
FAX : +822 - 3232 - 154

### SHOCK, FIRE HAZARD SERVICE TEST :

**CAUTION :** After servicing this appliance and prior to returning to customer, measure the resistance between either primary AC cord connector pins ( with unit NOT connected to AC mains and its Power switch ON ), and the face or Front Panel of product and controls and chassis bottom.

Any resistance measurement less than 1 Megohms should cause unit to be repaired or corrected before AC power is applied, and verified before it is return to the user/customer.

Ref. UL Standard No. 813.

In case of difficulties, do not hesitate to contact the Technical  
Department at above mentioned address.

# 1. TECHNICAL SPECIFICATIONS

## DIGITAL AUDIO SYSTEM

### System

MiniDisc digital audio system

### Disc

MiniDisc

### Recording method

Magnetic field modulation, overwrite system

### Reading method

Non-contact optical pickup (using semiconductor laser)

### Laser

Semiconductor laser

### Laser Diode Properties

Material: GaAlAs

Wavelength: 780 nm

### Record/playback time

SP mode (stereo): 80 minutes max.

LP mode (mono): 160 minutes max.

### Revolutions

Approx. 400~900 rpm (CLV)

### Error Correction

ACIRC (Advanced Cross Interleave Reed-solomon Code)

### Sampling frequency

44.1 kHz (32 kHz and 48 kHz signals converted to 44.1 kHz for recording)

### Coding

ATRAC (Adaptive Transform Acoustic Coding)

### Modulation System

EFM (Eight-to-Fourteen Modulation)

### Number of channels

2 (stereo) or 1 (mono)

## AUDIO SPECIFICATIONS

### Frequency Response

20 Hz ~ 20 kHz

### Signal-to-Noise Ratio (IEC-A weighted)

85 dB

### Total Harmonic Distortion (at 0 VU)

0.02%

### Dynamic Range

85 dB

### Headphone Output Power

15 mW /32 ohms

### Speaker Output Power

200 mW

### Phantom Power

+48V, 5 mA

### Inputs:

Reference level: -12 dB (Full scale 0 dB)  
0 dBu = 0.775 Vrms

(MIC/LINE IN L/R)

Type: XLR (1: GND, 2: HOT, 3: COLD)

Input sensitivity (MIC): -60 dBu/9 kilohms

Input sensitivity (LINE): -20 dBu/47 kilohms  
(DIGITAL IN)

Type: coaxial (RCA) jack

Input impedance: 75 ohms

Input level: 0.5 Vp-p

### Outputs:

(LINE OUT L/R)

Type: RCA jack

Output level: 2 Vrms max./2 kilohms  
(DIGITAL OUT)

Type: XLR

Output impedance: 110 ohms

Output level: 3.3 Vp-p

## GENERAL

### Power Supply

DC 13 V

### Power Consumption

Recording: 5.5 W

Standby: 3.5 W

### Dimensions (W x H x D)

264 x 54.8 x 185 mm

### Weight (without battery)

1.3 kg (2 lbs. 14 oz.)

### Accessories

AC adaptor :

DA600PMDF [F version]

DA600PMDU [U version]

Battery holder: 1

Carrying Strap: 1

User Guide: 1

### Optional Accessories

AC adaptor :

74 DA600/02B, 74 DA600/05B : [N version]

NiCd Battery Pack (RB1100)

Carrying Case (74CLC650/09B)

Manufactured under license from Dolby Laboratories Licensing Corporation.

Specifications subject to change without notice.

## 2. SERVICE MODE

### 2-1. PRECAUTIONS FOR USE OF SERVICE MODE

1. As loading related operations will be performed regardless of the SERVICE MODE operations being performed, be sure to check that the disc is stopped before setting and removing it. Even if the **EJECT** switch is slid while the disc is rotating during continuous playback, etc., the disc will not stop rotating. Therefore, it will be ejected while rotating. Be sure to slide the **EJECT** switch after pressing the **STOP** button and the rotation of disc is stopped.
2. The erasing-protection tab is not detected in the SERVICE MODE. Therefore, when operating in the recording laser emission mode and pressing the **REC** button, the recorded contents will be erased regardless of the position of the tab. When using a disc that is not to be erased in the SERVICE MODE, be careful not to **ENTER** the continuous recording mode and traverse adjustment mode.

#### 2-1-1. Recording Laser Emission Mode and Operating Button

1. Continuous recording mode (CREC MODE)
2. Traverse adjustment mode (EFBAL ADJ)
3. Laser power adjustment mode (LDPWR ADJ)
4. Laser power check mode (LDPWR CHK)
5. When pressing the **REC** button.

### 2-2. HOW TO CONFIRM THE VERSION OF MICROPROCESSOR

1. Confirm the product with Power Off.
2. While holding the **FF/NEXT** button, at the same time slide the **POWER** switch.
3. And, the display shows "Ver=M@@S@@" (the version of microprocessor. M:QL04 S:QU01).
4. When the display shows the version of microprocessor, slide the **POWER** switch. Then the product will be in normal mode.

### 2-3. HOW TO SET THE SERVICE MODE

1. Confirm the product with Power Off.
2. While holding the **PLAY/PAUSE** button, at the same time slide the **POWER** switch (At this moment the display shows "Test Mode?" with blinking.).
3. Press the **ENTER** button.
4. It will be the service mode. Then the display shows "TEMP ADJ" (the first content of table 2-2).

### 2-3. HOW TO STOP THE SERVICE MODE

Slide the **POWER** switch.

## 2. サービスモード

### 2-1. サービスモード使用時の注意

1. ローディング関係の動作が、サービスモードの動作とは全く無関係に働くので、必ずディスクが停止したことを確認してからディスクの出し入れを行ってください。連続再生中等ディスクが回転中に **EJECT** スイッチをスライドしてもディスクの回転は停止しません。従って、ディスクが回転された状態でイジェクトされますので、必ず **STOP** ボタンを押してディスクの回転が止まってから **EJECT** スイッチをスライドしてください。
2. サービスモード時は、誤消去防止つめの検出を行いません。そのため次の項目に示す "記録用レーザーが発光するモード" での作業および、**REC** ボタンを押した時は、つめの位置の関係なくそれまでの記録内容が消去されます。従って、消去してはいけないうディスクをやむをえずサービスモード時に使用する場合、連続録音モードおよびトラバース調整モードに入らないように注意してください。

#### 2-1-1. 記録用レーザーが発光するモードおよびボタン操作

1. 連続録音モード (CREC MODE)
2. トラバース調整モード (EFBAL ADJ)
3. レーザーパワー調整モード (LDPWR ADJ)
4. レーザーパワー確認モード (LDPWR CHK)
5. **REC** ボタンを押した時

### 2-2. マイコンバージョンの確認方法

1. Power OFF の状態にします。
2. まず、**FF/NEXT** ボタンを押しながら、さらに、Power ON すると、ディスプレイに「Ver=M@@S@@"とマイコンのバージョンが表示されます。(M:QL04 S:QU01)
3. マイコンバージョン表示のときは、一度 Power OFF するまで通常動作になりません。

### 2-3. サービスモードの設定方法

1. Power OFF の状態にします。
2. まず、**PLAY** ボタンを押しながら、次に Power ON すると、ディスプレイに「Test Mode?」と点滅します。
3. **ENTER** ボタンを押すとサービスモードになります。
4. この時、ディスプレイ表示は表 2-2 の 1 行目「TEMP ADJ」が表示されます。

### 2-3. サービスモードの解除方法

**Power** OFF します。以後通常動作になります。

## 2-4. BASIC OPERATIONS OF THE SERVICE MODE

All operations are performed using the **STOP** button, **ENTER** button, and **EDIT(<, >)** buttons. The functions of these buttons are as follows.

Table 2-1.

Button	Function
<b>EDIT(&lt;, &gt;)</b> button	Changes parameters and modes.
<b>ENTER</b> button	Finalizes input.
<b>STOP</b> button	Stops operations.

## 2-5. SELECTING THE SERVICE MODE

Nine SERVICE MODEs are selected by using the **EDIT(<, >)** buttons.

Table 2-2.

Display	Contents
TEMP ADJ	Temperature compensation offset adjustment
LDPWR ADJ	Laser power adjustment
LDPWR CHK	Laser power check
EFBAL ADJ	Traverse (E-F balance) adjustment
FBIAS ADJ	Focus bias adjustment
FBIAS CHK	Focus bias check
CPLAY MODE	Continuous playback mode
CREC MODE	Continuous recording mode
EEP MODE	Non-volatile memory mode (*1)

- For detailed description of each adjustment mode, refer to the "MD UNIT ELECTRICAL ADJUSTMENTS".
- If a different adjustment mode has been selected by mistake, press the **STOP** button to exit from it.
- \*1: The EEP MODE is not used in servicing. If set accidentally, press the **STOP** button immediately to exit it.

## 2-6. EEP MODE

This mode reads and writes the contents of the non-volatile memory.

It is not used in servicing. If set accidentally, press the **STOP** button immediately to exit it.

## 2-7. FUNCTIONS OF OTHER BUTTONS

Table 2-3.

Button	Contents
▶▶	The sled moves to the outer circumference only when this is pressed.
◀◀	The sled moves to the inner circumference only when this is pressed.

**Note :** The erasing-protection tab is not detected during the SERVICE MODE. Recording will start regardless of the position of the erasing-protection tab when the REC button is pressed.

## 2-4. サービスモードの基本操作

全ての操作は**STOP**ボタン、**ENTER**ボタンおよび**EDIT(<, >)**ボタンで行います。

表2-1にそれぞれの機能を記します。

表2-1

ボタン	機能
EDIT(<, >) ボタン	パラメータおよびモードの変更
ENTER ボタン	確定する。
STOP ボタン	中断する。項目選択に戻る

## 2-5. サービスモードの選択

サービスモードは表2-2に示す9項目があり、各テストモードの選択は**EDIT(<, >)**ボタンで選択します。

表2-2

ディスプレイ表示	機能
TEMP ADJ	温度補償オフセット調整
LDPWR ADJ	レーザーパワー調整
LDPWR CHK	レーザーパワー確認
EFBAL ADJ	トラバース(E-Fバランス)調整
FBIAS ADJ	フォーカスバイアス調整
FBIAS CHK	フォーカスバイアス確認
CPLAY MODE	連続再生モード
CREC MODE	連続録音モード
EEP MODE	不揮発性メモリモード*1

- 各調整モードの詳しい説明は、"MDユニット電気調整"の各項目を参照してください。
- 誤って別の調整モードに入ってしまった場合は、**STOP**ボタンを押しそのモードから抜けてください。
- \*1: EEP MODEは、各調整時自動処理されるので、このモードを直接選択しないでください。誤ってこのモードに入ってしまった場合はすぐに、**STOP**ボタンを押しこのモードから抜けてください。

## 2-6. EEPモード

EEPモードは不揮発性メモリの内容の読み書きを行うモードですが、このモードは各調整時自動処理されるので、このモードを直接選択しないでください。

従って、誤ってこのモードに入ってしまった場合はすぐに、**STOP**ボタンを押しこのモードから抜けてください。

## 2-7. その他のボタンの機能

表2-3

ボタン	機能
▶▶	ボタンを押している間だけスレッドが外周方向に動く。
◀◀	ボタンを押している間だけスレッドが内周方向に動く。

**注意 :** サービスモード時は、誤消去防止のための検出を行います。RECボタンを押すと誤消去防止のための位置に関係なく録音されますので注意してください。

### 3. MD MODULE(KML-252 with PCB) ELECTRICAL ADJUSTMENTS

#### 3-1. PRECAUTIONS FOR CHECKING LASER DIODE EMISSION

To check the emission of the laser diode during adjustments, never view directly from the top as this may cause loss of eyesight.

#### 3-2. PRECAUTIONS FOR USE OF OPTICAL PICK-UP

As the laser diode in the optical pick-up is easily damaged by static electricity, solder the laser tap of the flexible board when using it.

Before disconnecting the connector, de-solder first. Before connecting the connector, be careful not to remove the solder. Also take adequate measures to prevent damage by static electricity. Handle the flexible board with care as it breaks easily.

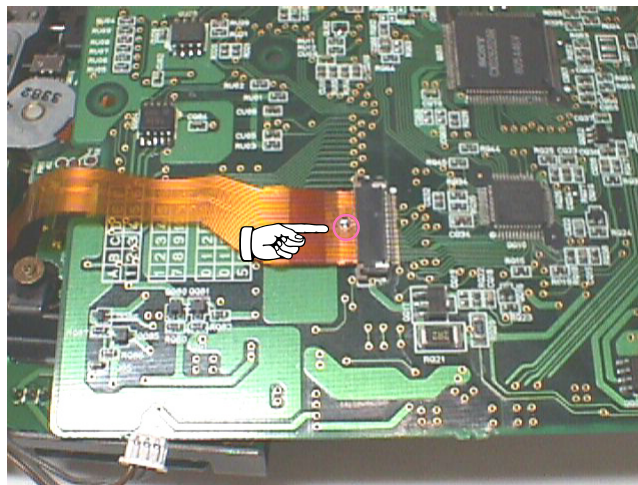

Optical pick-up flexible board

#### 3-3. PRECAUTIONS FOR ADJUSTMENTS

1. When replacing the following parts, perform the adjustments and checks with O in the order shown in the following table.

Notes:

The following tools and measuring devices are necessary for the adjustments.

- Laser power meter ( TQ8210 )
- Optical sensor ( TQ82017 )
- Oscilloscope (Measure after pre-forming CAL of probe.)
- Jitter meter
- Thermometer

If you cannot prepare them, please replace the adjusted MD module <Part Number : ZZ409S3010> (refer to "5. HOW TO DISASSEMBLE Fig.15").

### 3. MD モジュール(KML-252 with PCB) 電気調整

#### 3-1. レーザーダイオード発光確認時の注意

調整時にレーザーダイオードの発光を確認する場合は失明のおそれがありますので絶対に真上から覗かないでください。

#### 3-2. 光ピックアップ取扱時の注意

光ピックアップ内のレーザーダイオードは非常に静電破壊し易いため、取扱時はフレキシブル基板のレーザータップを半田ブリッジしてください。

コネクタから外す時は、事前に半田ブリッジをしてから外してください。またコネクタを差す前に半田ブリッジをとらないように注意してください。また静電破壊を防止する対策を充分に行い作業してください。フレキシブル基板は切れ易いので取扱に注意してください。

#### 3-3. 調整時の注意

1. 下記の部品を交換した時は、○印の調整、確認を下記表の順番で行ってください。

注意：

以降の調整を行うには、下記の治具、測定器が必要です。

- レーザーパワーメータ (アドバンテスト TQ8210 )
- オプティカル センサー (アドバンテスト TQ82017 )
- オシロスコープ  
(プローブのCALを行ってから測定してください。)
- ジッターメータ
- 寒暖計

上記の治具、測定器がない場合には、調整済のMDモジュール <Parts Number : ZZ409S3010> (5. 分解方法の Fig.15 を参照) の交換を行ってください。

Table 3-1.

MD board	MD Mechanism KML-252 (001M)	MD circuit		
		QU20	DQ10	QU01, QQ01, QQ10, QQ50
1. Temperature compensation offset adjustment	X	○	○	○
2. Laser power	○	○	X	○
3. Traverse adjustment	○	○	X	○
4. Focus bias adjustment	○	○	X	○
5. Error rate check	○	○	X	○

- Set the SERVICE MODE when performing adjustments.  
After completing the adjustments, exit the SERVICE MODE.
- Perform the adjustments in the order shown.
- When observing several signals on the oscilloscope, etc., make sure that VC and ground do not connect inside the oscilloscope.  
(VC and ground will become short-circuited)
- Test disc

Table 3-2

High reflection disc	A-BEX, TMD-381, for audio performance measurement
Low reflection disc	Blank disc on market for Rec/Play
Eccentricity disc	A-BEX, TMD-311R, Confirm Rec/Play operation
Surface distortion disc	A-BEX, TMD-331R, Confirm Rec/Play operation

### 3-4. CREATING CONTINUOUSLY RECORDED DISC

This disc is used in focus bias adjustment and error rate check. The following describes how to create a continuous recording disc.

- Set the SERVICE MODE.
  - Insert a low reflection disc (blank disc) commercially available.
  - Use the **EDIT**(**<**, **>**) buttons and display "CREC MODE".
  - Press the **ENTER** button and display "CREC MID".  
"CREC (0300)" is displayed and recording starts.
  - Complete recording within 5 minutes.
  - Press the **STOP** button and stop recording.
  - Slide the **EJECT** switch and remove the low reflection disc.
- The above has been how to create a continuous recording data for the focus bias adjustment and error rate check.

**Note :** Be careful not to apply vibration during continuous recording.

### 3-5. TEMPERATURE COMPENSATION OFFSET ADJUSTMENT

Save the temperature data at that time in the non-volatile memory as 25 °C reference data.

**Notes :**

- Usually, do not perform this adjustment.

表 3-1

	MD Mechanism KML-252 (001M)	MD 回路		
		QU20	DQ10	QU01,QQ01,QQ10,QQ50
1. 温度補償オフセット調整	×	○	○	○
2. レーザーパワー調整および確認	○	○	×	○
3. トラバース調整	○	○	×	○
4. フォーカスバイアス調整	○	○	×	○
5. エラーレート確認	○	○	×	○

- 調整はサービスモードにして行ってください。  
調整終了後はサービスモードを解除してください。
- 調整は掲載順に行ってください。
- オシロスコープ等で複数の信号を見る場合、VC と GND がオシロスコープ内部で接続されないようにしてください。  
(VC と GND がショートしてしまいます。)
- テストディスク

表 3-2

高反射ディスク	A-BEX TMD-381 Audio パフォーマンス測定用
低反射ディスク	市販録再用
偏心ディスク	A-BEX TMD-311R 録再確認
面振れディスク	A-BEX TMD-331R 録再確認

### 3-4. 連続録音ディスクの作り方

このディスクはフォーカスバイアス調整および確認、エラーレート確認において使用するディスクです。以下その連続録音ディスクの作り方を記します。レーザーは通常、間欠発光ですが、連続録音中は連続発光しています。

- 市販の低反射ディスク(ブランクディスク)を挿入する。
  - EDIT**(**<**, **>**)ボタンを押して表示を "CREC MODE" にする。
  - ENTER** ボタンを押すと "CREC MID" になる。  
"CREC 0300" と表示し録音を始める(数字が変化する)。
  - 5分間以内に録音を終わってください。
  - STOP** ボタンを押して録音を止める。
  - EJECT** スイッチをスライドして低反射ディスクを取り出す。
- 以上でフォーカスバイアス調整および確認、エラーレート確認用の連続録音ディスクを作ることができます。
- 注意 :** 連続録音中は振動などが加わらないように注意してください。

### 3-5. 温度補償オフセット調整

その時点の温度データを25 基準データとして不揮発性メモリにセーブします。

**注意 :**

- 通常、この調整は行わないでください。
- この調整を行う際の周囲温度は22 ~ 28 の範囲で行うようにしてください。また、セットの内部温度が周囲温度と同じ22 ~ 28 の状態である電源投入直後に行ってください。
- DQ01交換後は、部品の温度が十分周囲温度になってからこの調整を行ってください。

2. Perform this adjustment in an ambient temperature of 22 °C to 28 °C. Perform it immediately after the power is turned on when the internal temperature of the unit is the same as the ambient temperature of 22 °C to 28 °C.
3. When DQ10 has been replaced, perform this adjustment after the temperature of this part has become the ambient temperature.

#### Adjusting Method:

1. Selected by Use the **EDIT**(**<**, **>**) buttons and display "TEMP ADJ".
2. Press the **ENTER** button. The display shows "TEMP +25C". By using the **EDIT**(**<**, **>**) buttons, set the current temperature.
3. To save the data, press the **ENTER** button.
4. When the **ENTER** button is pressed, "DATA SAVE" will be displayed for 1 second, followed by "TEMP ADJ".

### 3-6. LASER POWER ADJUSTMENT

#### Connection:

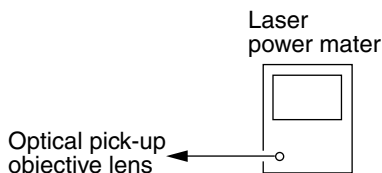

#### Adjusting Method:

1. Set the sensor disc of power meter into the MD mechanism.
2. Selected by Use the **EDIT**(**<**, **>**) buttons and display "LDPWR ADJ". (Laser power : for adjustment)
3. Press the **ENTER** button and display "LD 0.9 \$□□". (Then the pickup will move to inside automatically.)
4. Selected by Use the **EDIT**(**<**, **>**) buttons so that the reading of the laser power meter becomes 0.88 to 0.92 mW.  
Set the range control on the laser power meter to 10 mW, then press the **ENTER** button to save the adjustment result in the non-volatile memory. ("DATA SAVE" will be displayed for a moment.)
5. Then "LD 7.0 \$□□" will be displayed.
6. Press the **PLAY** button, selected by Use the **EDIT**(**<**, **>**) buttons so that the reading of the laser power meter becomes 6.95 to 7.05 mW, press the **ENTER** button and save the adjustment result in the non-volatile memory. ("DATA SAVE" will be displayed for a moment.)  
**Note** : The emission stops after 10 seconds automatically.  
When the adjustment resume, press the **PLAY** button.
7. Selected by Use the **EDIT**(**<**, **>**) buttons and display "LDPWR CHK".
8. Press the **ENTER** button and display "LD 0.9 \$□□".  
Check that the reading of the laser power meter becomes 0.80 to 0.96 mW.
9. Press the **ENTER** button and display "LD 7.0 \$□□".  
Check that the reading of the laser power meter satisfy 6.95 to 7.05 mW.

#### 調整方法 :

1. **EDIT**(**<**, **>**)ボタンを押して表示を "TEMP ADJ" にする。
2. **ENTER**ボタンを押すと"TEMP +25"と表示される。その時**EDIT**(**<**, **>**)ボタンを使って現在の室温に合わせる。
3. 温度表示を室温に合わせた後、**ENTER**ボタンを押すと入力したデータをEEPROMに書き込み、"DATA SAVE" を1秒間表示してから項目選択に戻ります。

### 3-6. レーザーパワー調整および確認

#### 接続 :

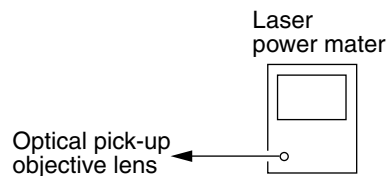

#### 調整方法 :

1. レーザーパワーメータのセンサーMDディスクをMDメカにセットする。
2. **EDIT**(**<**, **>**)ボタンを押して表示を "LDPWR ADJ" にする。(レーザーパワー : 調整用)
3. **ENTER**ボタンを押して表示を "LD 0.9 \$□□" にする。(この時、ピックアップは自動的に最内周に移動する。)
4. レーザーパワーメータの読みが0.9 mW ± 0.02 mWになるように**EDIT**(**<**, **>**)ボタンを押して調整する。次にレーザーパワーメータのレンジつまみを10 mWにセットしてから**ENTER**ボタンを押して不揮発性メモリに調整結果をセーブする。(この時、一瞬 "DATA SAVE" と表示される。)
5. 表示が "LD 7.0 \$□□" になる。
6. **PLAY**ボタンを押して(レーザーが発光する)、レーザーパワーメータの読みが7.0 mW ± 0.05 mWになるように**EDIT**(**<**, **>**)ボタンを押して調整し、**ENTER**ボタンを押して不揮発性メモリに調整結果をセーブする。(この時、一瞬 "DATA SAVE" と表示される。)  
**注意** : 発光は、10秒で自動的に停止しますが、その場合は**PLAY**ボタンを押して、調整を行ってください。
7. **EDIT**(**<**, **>**)ボタンを押して表示を "LDPWR CHK" にする。
8. **ENTER**ボタンを押して表示を "LD 0.9 \$□□" にする。この時のレーザーパワーメータの読みが0.9 mW ± 0.02 mWであることを確認する。
9. **ENTER**ボタンを押して表示を "LD 7.0 \$□□" にする。この時のレーザーパワーメータの読みが7.0 mW ± 0.05 mWであることを確認する。
10. **STOP**ボタンを押してレーザー発光を止める。表示は "LDPWR CHK" に戻る。  
**STOP**ボタンはいつでも受け付け、レーザー発光を止めます。

### 3-7. トラバース(E-Fバランス)調整

トラバース調整には、2種類のディスクで4つのデータをセーブします。

**注意** : 記録済ディスクをこの調整に使用すると書き込み時データが消去されます。



10. Press the **STOP** button and display "LDPWR CHK". and stop the laser emission.

The **STOP** button is effective at all times to stop the laser emission.

### 3-7. TRAVERSE (E-F BALANCE) ADJUSTMENT

**Note 1** : Data will be erased during MO reading if a recorded disc is used in this adjustment.

**Note 2** : If the traverse waveform is not clear. connect the oscilloscope as shown in the following figure so that it can be seen more clearly.

#### Connection:

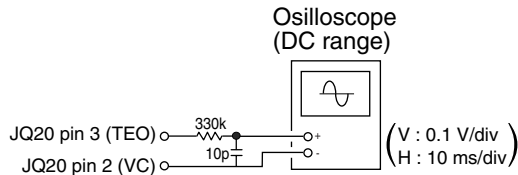

#### Adjusting Method:

1. Connect an oscilloscope to JQ20 pin 3 (TEO) and JQ20 pin 2 (VC) of the MD board (PQ01).
2. Load a low reflection disc (any available on the market). (Refer to Note 1.)
3. Press the **▶▶** button or **◀◀** button and move the optical pick-up outside the pit.
4. Use the **EDIT(<, >)** buttons and display "EFBAL ADJ".
5. Press the **ENTER** button and display "EFBAL MO". (Laser power READ power/Focus servo ON/tracking servo OFF/spindle (S) servo ON)
6. Press the **ENTER** button.
7. Use the **EDIT(<, >)** buttons so that the waveforms of the oscilloscope becomes the specified value. (When the the **EDIT(<, >)** buttons is Used, the "□□" of "MOr EFB=□□" changes and the waveform changes.) In this adjustment, waveform varies at intervals of approx. 2%. Adjust the waveform so that the specified value is satisfied as much as possible. (MO read power traverse adjustment)

(Traverse Waveform)

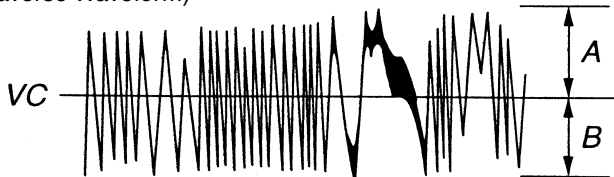

specification : A = B

8. Press the **ENTER** button, and save the result of adjustment to the non-volatile memory. ("DATA SAVE" will be displayed for a moment. Then "MOW EFB= □□" will be displayed.) The optical pick-up moves to the pit area automatically and servo is imposed.
9. Use the **EDIT(<, >)** buttons so that the waveforms of the oscilloscope becomes the specified value. (When the the **EDIT(<, >)** buttons is Used, the "□□" of "MOW EFB= □□" changes and the waveform changes.) In this adjustment, waveform varies at intervals of approx. 2%. Adjust the waveform so that the specified value is satisfied as much as possible.

接続 :

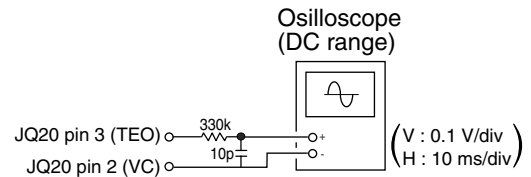

#### 調整方法 :

1. オシロスコープをMD基板(PQ01)のJQ20 3ピン(TEO)とJQ20 2ピン(VC)に接続する。
2. 市販の低反射ディスク(ブランクディスク)を挿入する。(注意 . 参照)
3. **▶▶**ボタン、**◀◀**ボタンを押して光ピックアップをピット部より外周に移動する。
4. **EDIT(<, >)**ボタンを押して表示を"EFBAL ADJ"にする。
5. **ENTER**ボタンを押して表示を"EFBAL MO"にする。  
(これはレーザーパワー : READパワー , フォーカスサーボ : ON, トラッキングサーボ : OFF, スピンドル(S)サーボ : ONの状態)
6. 再度、**ENTER**ボタンを押します。
7. オシロスコープの波形が規格値になるように **EDIT(<, >)**ボタンを押して調整する。  
(**EDIT(<, >)**ボタンを押すと、"MOr EFB=□□"の"□□"数字が変化し、波形も変化します。) この調整は約2%刻みで変化し、最も規格値に近づくように調整する。  
(MOリードパワートラバース調整)

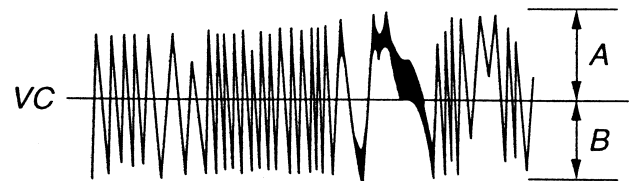

(トラバース波形 規格 : A = B)

8. **ENTER**ボタンを押して不揮発性メモリに調整結果をセーブする。(この時、一瞬"DATA SAVE"と表示される。) その後に"MOW EFB=□□"と表示される。自動的にピット部の内周まで光ピックアップが移動してサーボがかかる。
9. この時のオシロスコープの波形が規格値に近づくように **EDIT(<, >)**ボタンを押して調整する。  
(**EDIT(<, >)**ボタンを押すと、"MOW EFB=□□"の"□□"数字が変化し、波形も変化します。) この調整は約2%刻みで変化し、最も規格値に近づくように調整する。  
(MOライトパワートラバース調整)

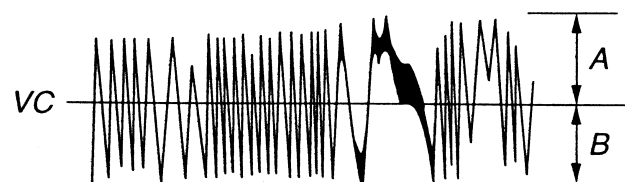

(トラバース波形 規格 : A = B)

10. **ENTER**ボタンを押して不揮発性メモリに調整結果をセーブする。(この時、一瞬"DATA SAVE"と表示される。) その後"MOp EFB=□□"と表示される。

(Traverse Waveform)

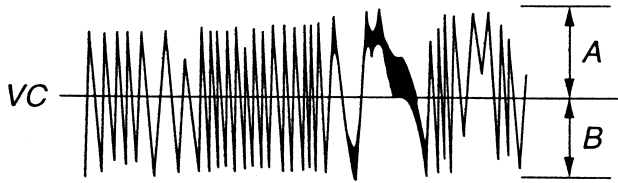

specification : A = B

10. Press the **ENTER** button, and save the result of adjustment to the non-volatile memory. ("DATA SAVE" will be displayed for a moment. Then "MOp EFB=□□" will be displayed.)

11. Use the **EDIT(<, >)** buttons so that the waveforms of the oscilloscope becomes the specified value. (When the the **EDIT(<, >)** buttons is Used, the "□□" of "MOp EFB=□□" changes and the waveform changes.) In this adjustment, waveform varies at intervals of approx. 2%. Adjust the waveform so that the specified value is satisfied as much as possible.

(MO write power traverse adjustment)

(Traverse Waveform)

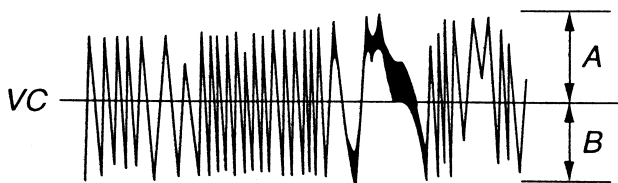

specification : A = B

12. Press the **ENTER** button, and save the result of adjustment to the non volatile memory. ("DATA SAVE" will be displayed for a moment.) Then "MOp EFB= □□" will be displayed.

13. Slide the **EJECT** switch and remove the low reflection disc.

14. Load the test disc. ( High reflection disc TMD-381 )

15. Press the **ENTER** button and display "CD EFB= □□".

16. Press the **ENTER** button. Servo is imposed automatically.

17. Use the **EDIT(<, >)** buttons so that the waveforms of the oscilloscope becomes the specified value. (When the the **EDIT(<, >)** buttons is Used, the "□□" of "CD EFB= □□" changes and the waveform changes.) In this adjustment, waveform varies at intervals of approx. 2%. Adjust the waveform so that the specified value is satisfied as much as possible.

(Traverse Waveform)

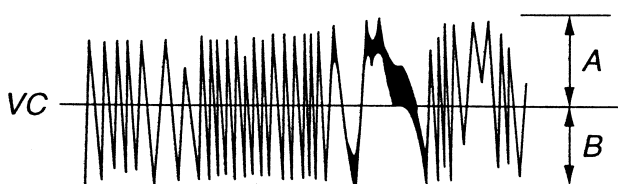

specification : A = B

11. オシロスコープの波形が規格値になるように **EDIT(<, >)** ボタンを押して調整する。

(**EDIT(<, >)** ボタンを押すと、"MOp EFB=□□" の "□□" 数字が変化し、波形も変化します。)

この調整は約 2% 刻みで変化し、最も規格値に近づくように調整する。

(ビットトラバース調整)

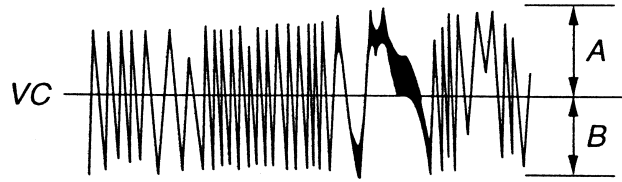

(トラバース波形 規格 : A = B)

12. **ENTER** ボタンを押して不揮発性メモリに調整結果をセーブする。(この時、一瞬 "DATA SAVE" と表示される。)

13. **EJECT** スイッチをスライドして低反射ディスクを取り出す。

14. テストディスク 高反射ディスク A-BEX TMD-381 を挿入する。

15. **ENTER** ボタンを押して表示を "CD EFB=□□" にする。

16. 再度、**ENTER** ボタンを押します。自動的にサーボがかかります。

17. オシロスコープの波形が規格値に近づくように **EDIT(<, >)** ボタンを押して調整する。

(**EDIT(<, >)** ボタンを押すと、"CD EFB=□□" の "□□" 数字が変化し、波形も変化します。)

この調整は約 2% 刻みで変化し、最も規格値に近づくように調整する。

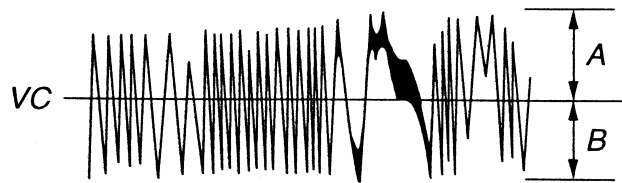

(トラバース波形 規格 : A = B)

18. **ENTER** ボタンを押して不揮発性メモリに調整結果をセーブする。(この時、一瞬 "DATA SAVE" と表示される。)

その後に "EFBAL ADJ" と表示される。

19. **EJECT** スイッチをスライドしてテストディスク 高反射ディスク A-BEX TMD-381 を取り出す。

### 3-8. フォーカスバイアス調整

接続 :

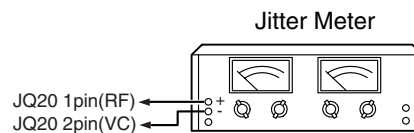

調整方法 :

1. 連続録音済ディスク ("3-4. 連続録音ディスクの作り方" を参照してください。) を挿入する。

2. **EDIT(<, >)** ボタンを押して表示を "FBIAJ ADJ" にする。

3. **ENTER** ボタンを押して表示を "a = □□" にする。

18. Press the **ENTER** button, and save the result of adjustment to the non-volatile memory. ("DATA SAVE" will be displayed for a moment. Then "EFBAL ADJ" will be displayed.)
19. Press the **EJECT** switch and remove the test disc. ( High reflection disc TMD-381 )

### 3-8. FOCUS BIAS ADJUSTMENT

#### Connection:

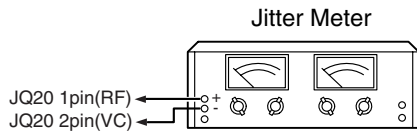

#### Adjusting Method:

1. Load a continuously recorded disc (Refer to "3-4. Creating MO Continuously Recorded. Disc").
  2. Use the **EDIT(<, >)** buttons and display "FBIAS ADJ".
  3. Press the **ENTER** button and display "a =  $\square\square$ ".
  4. Press the ">" of the **EDIT(<, >)** button and find the focus bias value at which the reading of the jitter meter becomes 27 ns to 30 ns. (Refer to note 2.) If the reading of the jitter meter is over 30 ns, press the "<" of the **EDIT(<, >)** button. It will be down.
  5. Press the **ENTER** button and display "b =  $\square\square$ ".
  6. Press the "<" of the **EDIT(<, >)** button and find the focus bias value at which the reading of the jitter meter becomes 27 ns to 30 ns. (Refer to note 2.) If the reading of the jitter meter is over 30 ns, press the ">" of the **EDIT(<, >)** button. It will be down.
- Note :** If the sarvo is out and it stops to adjust, press the **STOP** button. The display will show "ADJ CANCEL", and the display return to "FBIAS ADJ".
7. Press the **ENTER** button, and save the result of adjustment to the non-volatile memory. ("DATA SAVE" will be displayed for a moment. ) Then "c =  $\square\square$ " will be displayed.
  8. Press the **DISPLAY** button and display "C1  $\square\square\square$ AD  $\square\square$ " and check that the C1 error rate is below 50 and ADER is 00. Then press the **STOP** button. The first four digits indicate the C1 error rate, the two digits after indicate ADER.
  9. If the reading of the jitter meter is over 28 ns, press the **STOP** button ("FBIAS ADJ" will be displayed.) and adjust it again.
  10. Press the **STOP** button and slide the **EJECT** switch to remove the continuously recorded disc.

**Note 1 :** The relation between the C1 error and jitter meter is as shown in the following figure. Find points **a** and **b** in the following figure using the above adjustment. The focal point position **c** is automatically calculated from points **a** and **b**.

**Note 2 :** As the jitter meter changes, perform the adjustment using the average value.

4. **EDIT(>)**ボタン(必ず、>)を押してジッターメータ値が 27 ns ~ 30 nsになるフォーカスバイアス量を見つける。(注意2. 参照)30 nsを超えたときのみ(<)ボタンで少し下げる。(a点側のジッターの最大値を設定)
5. **ENTER** ボタンを押して表示を "b =  $\square\square$ " にする。
6. **EDIT(<)**ボタン(必ず、<)を押してジッターメータ値が 27 ns ~ 30 nsになるフォーカスバイアス量を見つける。(注意2. 参照)30 nsを超えたときのみ(>)ボタンで少し下げる。(b点側のジッターの最大値を設定)

**注意 :** サーボが外れたとき及び調整を中止するときは、**STOP** ボタンを押すと"ADJ CANCEL"を表示して(調整データはセーブされない。)、その後表示は"FBIAS ADJ"に戻る。(項目選択)

**STOP** ボタンはいつでも受け付け、調整を止めます。

7. **ENTER** ボタンを押して不揮発性メモリに調整結果をセーブする。(この時、一瞬 "DATA SAVE" と表示される。)その後 "c =  $\square\square$ " と表示される。(c 点は自動調整)
8. この時、**DISPLAY** ボタンを押して、"C1  $\square\square\square$ AD  $\square\square$ " と表示する。C1 エラーレート表示が 50 以下で ADER が 00 であることを確認して **STOP** ボタンを押す。最初の 4 桁の数字が C1 エラーレート、後の 2 桁の数字が ADER を示す。
9. ジッターメータ値が 28 ns 以上の時は **STOP** ボタンを押して再度、調整をする。"FBIAS ADJ" に戻る。(項目選択)
10. **STOP** ボタンを押し、次に **EJECT** スイッチをスライドして連続録音済ディスクを取り出す。

#### 注意 :

1. C1エラーとジッターメータ値の関係を示すと下図のようになります。上記調整で下図の **a**、**b** 点を見つけます。合焦点位置 **c** 点は **a**、**b** 点から自動的に計算し求めます。
2. ジッターメータ値は変動しますので、平均値を読み調整を行うようにしてください。

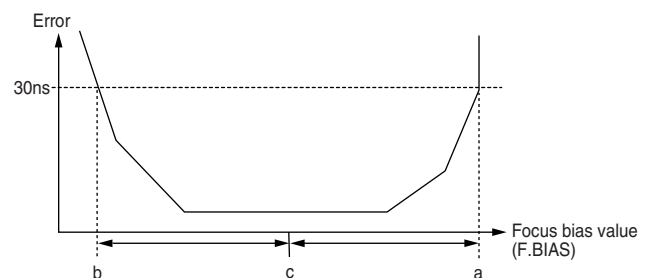

### 3-9. エラーレート確認

#### 3-9-1. 高反射ディスクエラーレート確認

##### 確認方法 :

1. 高反射ディスク A-BEX TMD-381 を挿入する。
2. **EDIT(<, >)**ボタンを押して表示を "CPLAY MODE" にする。
3. **ENTER** ボタンを押すと表示が 1 秒間 "CPLAY MID" となった後、表示が "C1  $\square\square\square$ AD  $\square\square$ " に変わる。
4. C1 エラーレートが 20 以下であることを確認する。
5. **STOP** ボタンを押して再生を止め、**EJECT** スイッチをスライドして高反射ディスクを取り出す。

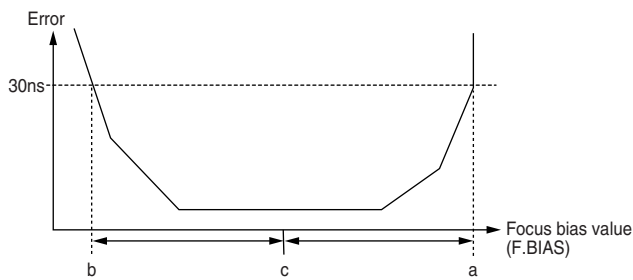

### 3-9. ERROR RATE CHECK

#### 3-9-1. High Reflection Disc Error Rate Check

##### Checking Method:

1. Load a test disc. ( High reflection disc TMD-381 )
2. Use the **EDIT**(<, >) buttons and display "CPLAY MODE" .
3. Press the **ENTER** button and the display shows "CPLAY MID" for 1 second. Then "C1□□□□AD□□" is displayed.
4. Check that the C1 error is below 20.
5. Press the **STOP** button, stop playback, slide the **EJECT** switch, and remove the test disc. ( High reflection disc TMD-381 )

#### 3-9-2. Low Reflection Disc Error Rate Check

##### Checking Method:

1. Load a continuously recorded disc (Refer to "3-4. Creating MO Continuously Recorded Disc".).
2. Use the **EDIT**(<, >) buttons and display "CPLAY MODE".
3. Press the **ENTER** button and the display shows "CPLAY MID" for 1 second. Then "C1□□□□AD□□" is displayed.
4. If the C1 error is below 50, check that ADER is 00.
5. Press the **STOP** button, stop playback, slide the **EJECT** switch and remove the continuously recorded disc.

### 3-10. FOCUS BIAS CHECK

Change the focus bias and check the focus tolerance amount.

##### Checking Method:

1. Load a continuously recorded disc (Refer to " 3-4. Creating Continuously Recorded Disc".).
2. Use the **EDIT**(<, >) buttons and display "FBIAS CHECK".
3. Press the **ENTER** button and display "c = □□".
4. Press the **DISPLAY** button and display "C1□□□□AD□□" .  
The first four digits indicate the C1 error rate, the two digits after indicate ADER. Check that the C1 error is below 50 and ADER is 00.
5. Press the **STOP** button, next slide the **EJECT** switch, and remove the continuously recorded disc.

### 3-9-2. 低反射ディスクエラーレート確認

##### 確認方法：

1. 連続録音済ディスク("3-4. 連続録音ディスクの作り方"を参照してください。)を挿入する。
2. **EDIT**(<, >)ボタンを押して表示を"CPLAY MODE"にする。
3. **ENTER**ボタンを押すと表示が1秒間"CPLAY MID"となった後、表示が"C1□□□□AD□□"に変わる。
4. C1エラーレートが50以下でADERが00であることを確認する。
5. **STOP**ボタンを押して再生を止め、**EJECT**スイッチをスライドして低反射ディスクを取り出す。

### 3-10. フォーカスバイアス確認

フォーカスバイアス量を変化させフォーカストランス量の確認をします。

##### 確認方法：

1. 連続録音済ディスク("3-4. 連続録音ディスクの作り方"を参照してください。)を挿入する。
2. **EDIT**(<, >)ボタンを押して表示を"FBIAS CHK"にする。
3. **ENTER**ボタンを押して表示を"c = □□"にする。次に**DISPLAY**ボタンを押すと"C1□□□□AD□□"を表示する。最初の4桁の数字がC1エラーレート、後の2桁の数字がADERを示す。この時のC1エラーレートが50以下でADERが00であることを確認する。
4. **STOP**ボタンを押して再生を止め、**EJECT**ボタンをスライドして連続録音済ディスクを取り出す。

#### 4. LCD CONTRAST ADJUSTMENT

1. Connect the TEST POINT (See below) with the tester.
2. Turn the variable resistor RF09 so that the reading of the testor becomes  $7.0\text{ V} \pm 0.1\text{ V}$  and conform the contrast of the LCD becomes maximum.

#### 4.LCD 輝度電圧調整

1. LCDモジュールとメイン基板をペアーとして以下の調整をおこなってください。
2. TEST POINT にテスターを接続し、輝度電圧測りながらボリューム RF09 の抵抗値を調整する。
3. LDCを正面から見て、コントラストが最大になることを確認しながら輝度電圧を  $7.0\text{V} \pm 0.1\text{V}$  に調整する。

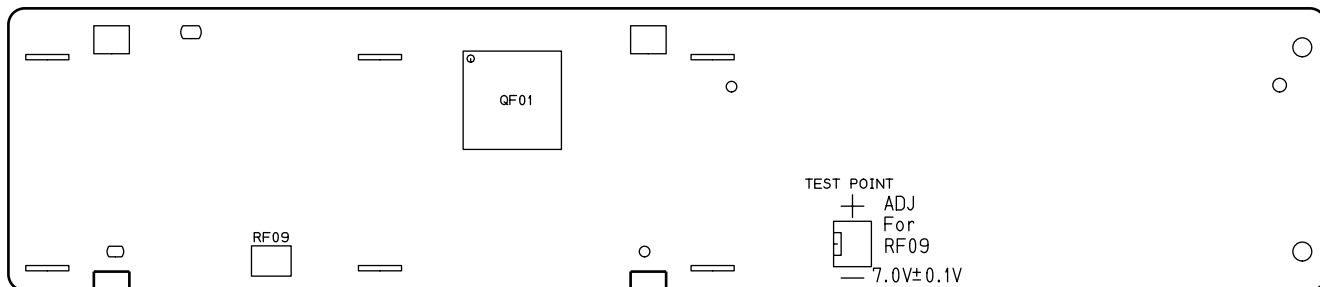

#### 5. HOW TO DISASSEMBLE

##### 1. Taking the MD module apart

- 1) Remove 7 screws as shown in Fig.1.

#### 5. 分解方法

##### 1. MDモジュールの外し方

- 1) 下図1に示すビス7本を外します。

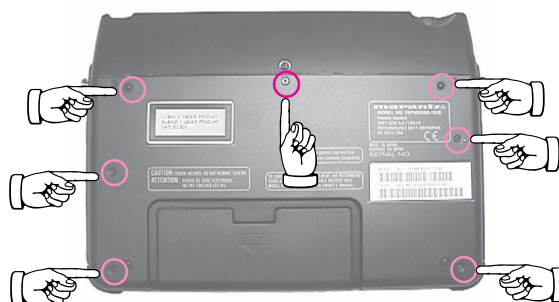

<Fig.1 Position of 7 screws>

- 2) Remove the battery cover.
- 3) Remove 4 screws as shown in Fig.2.

- 2) バッテリーカバーを外します。
- 3) 下図2に示すビス4本を外します。

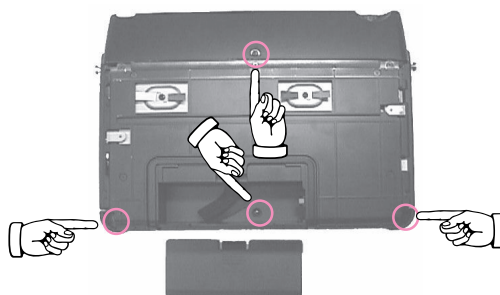

<Fig.2 Position of 4 screws>

- 4) Remove 2 screws from both sides as shown in Fig.3 and Fig.4.

- 4) 下図3～4に示す両サイドのビス計2本を外します。

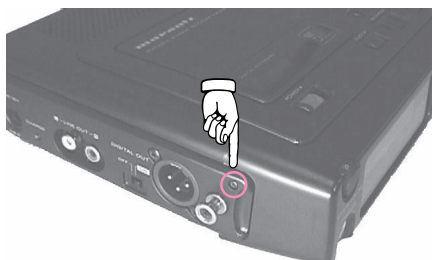

<Fig.3 Position of screw>



<Fig.4 Position of screw>

5) Remove the front panel, holding it and pushing down with thumb as shown in Fig.5 and Fig.6.

5) フロントパネルを下図5 ~ 6 の位置を指で押さえながら外します。



<Fig.5 Holding position>

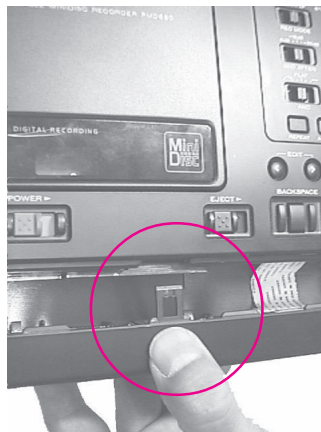

<Fig.6 Removing the front panel>

6) Remove 4 screws as shown in Fig.7.

6) 下図7に示すビス2本を外します。



<Fig.7 Position of 4 screws>

7) Remove 5 connectors and screw as shown in Fig.8. And remove the top case.

7) トップケースを持ち上げます。下図8 に示す5つのコネクタとビスを外し、トップケースを外します。

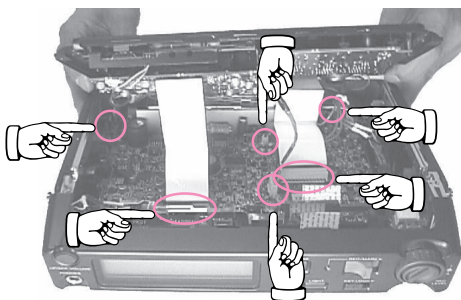

<Fig.8 Position of connectors>

8) Remove 4 screws as shown in Fig.9.

8) 下図9に示すMDメカユニット部分のビス4本を外します。

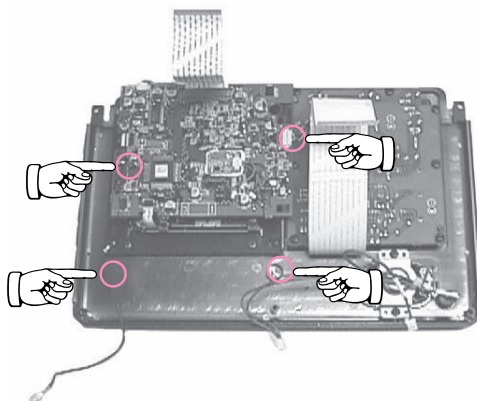

<Fig.9 Position of 4 screws>

9) Remove the MD unit part.

9) MDメカユニット部分を取り外します(図10)。

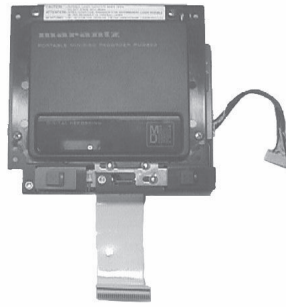

<Fig.10 The part of the MD unit>

10) Remove 2 screws as shown in Fig.11.

10) 下図11のビス2本外します。

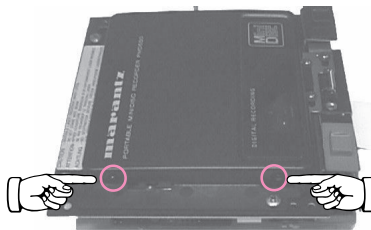

<Fig.11 Position of 2 screws>

11) Lift up the MD lid. Remove the hinge.

11) MDの蓋を持ち上げます(図12)。HINGEを外します(図13)。

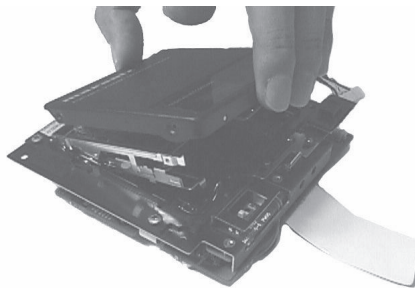

<Fig.12 lifting up the MD lid>

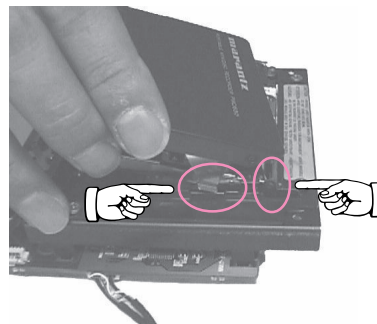

<Fig.13 Removing the hinge>

12) Remove the MD lid. Remove the lever of EJECT and POWER and the cables.

12) MDの蓋を取り外します。EJECT、POWER スイッチレバーとケーブル2本を外します(図14)。

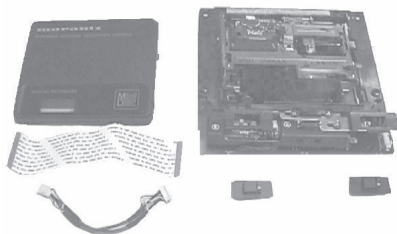

<Fig.14 Removed the MD module>

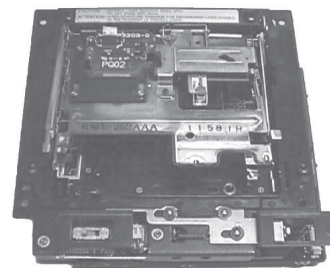

<Fig.15 The MD module (Part Number : ZZ409S3010)>

Notes:

When the MD module is replaced, please confirm the version of  $\mu$ -Processors, QU01 and QL04 (refer to "7. BUGS AND PROBLEMS").

注意 :

MDモジュールを交換する際は、2つのマイコン(QU01、QL04)のバージョンを確認してください。詳しくは、7.不具合対応を参照してください。

## 2. Taking The MD PCB apart

13) Remove 3 cables and screw as shown in Fig.16.

## 2. MD基板の外し方

13) 下図16に示すコネクタ3つ、ビス1本を外します。

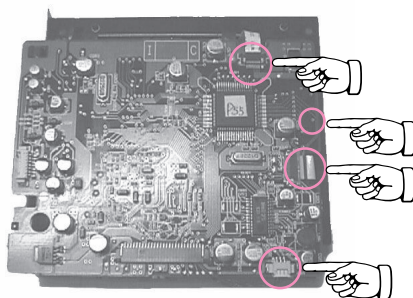

<Fig.16 Position of 3 cables and screws>

14) Turn over the MD PCB.

14) 基板を裏返します(図17)。

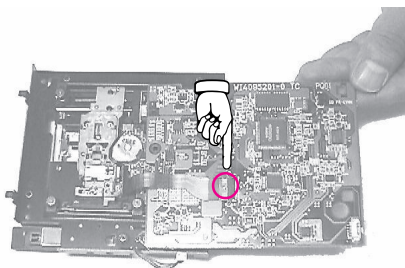

<Fig.17 Turning over the MD PCB>

15) Solder in the position as shown in Fig.18. Then remove the connector.

15) 下図18に示す部分に半田を付けます。それから、コネクタを外します。

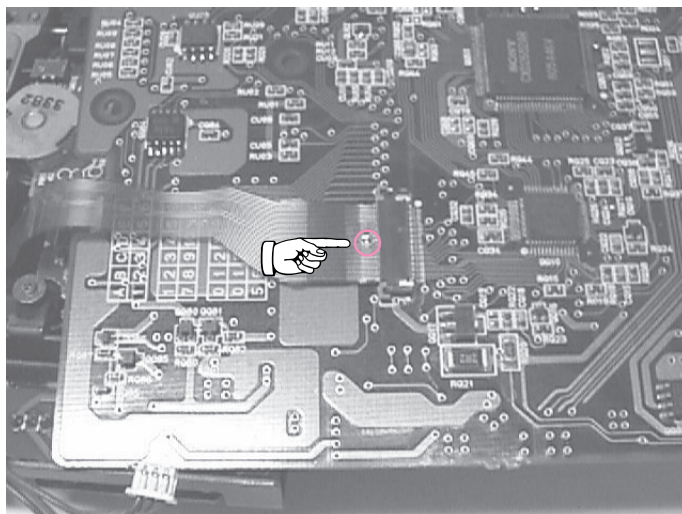

<Fig.18 Soldering position>

## 3. Taking the MD mechanism a part

16) Remove 4 screws as shown in Fig.19.

## 3. MD メカの外し方

16) 下図19のビス4本を外します。

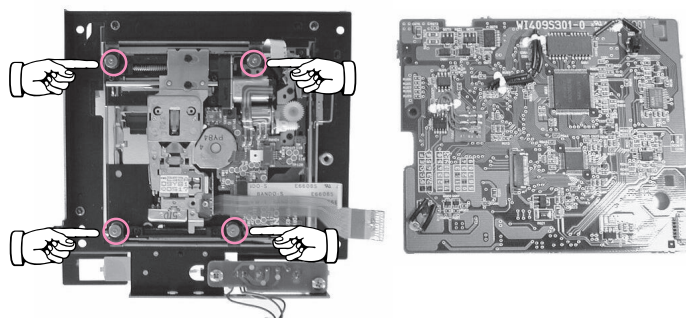

<Fig.19 Position of 4 screws>



17) Remove the MD mechanism.

17) MDメカを外します。

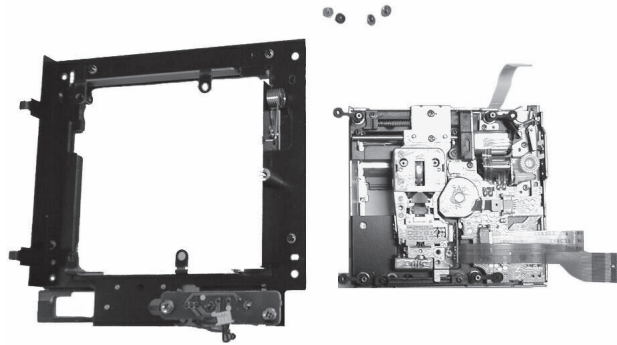

<Fig.20 The MD mechanism>

4. The spare parts of MD mechanism (KML-252)

4. MD メカ(KML-252)のスペアパーツ

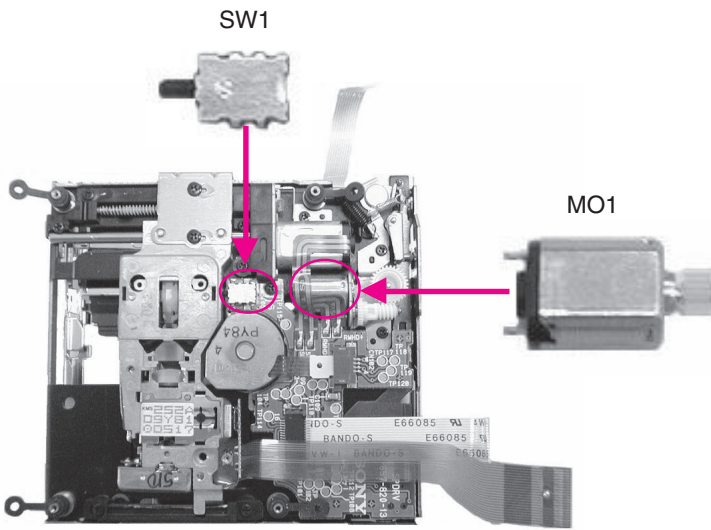

<Fig.21>

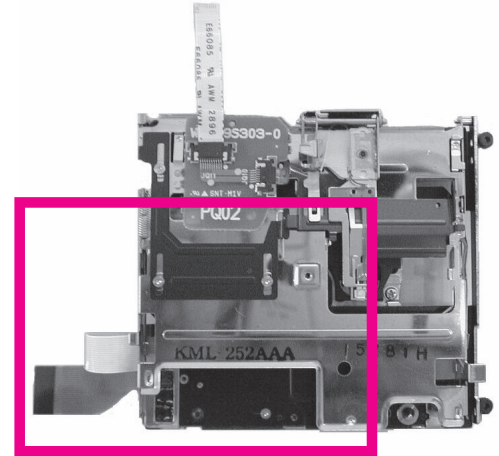

<Fig.22>

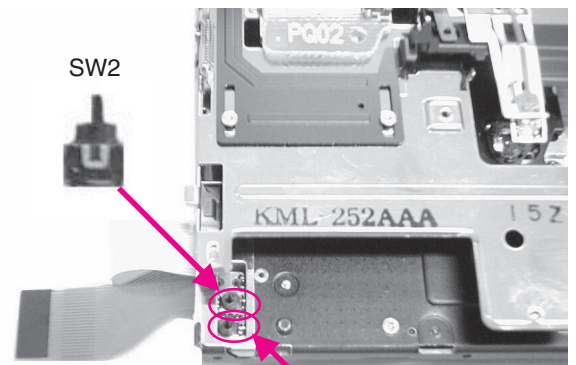

<Fig.23>



No.	PART No.	DESCRIPTION
MO1	*MM001030R	MOTOR FOR EJECT LOCK
SW1	*SP000970R	SWITCH FOR PICK-UP
SW2	*SP000950R	SWITCH (SHORT)
SW3	*SP000960R	SWITCH (LONG)

## 5. Caution on reassemble

18) When reattaching the lid, position the hook as shown in Fig.19.

## 5. 組立時の注意

18) MDの蓋を取り付ける時、金具を図19に示すように合せます。

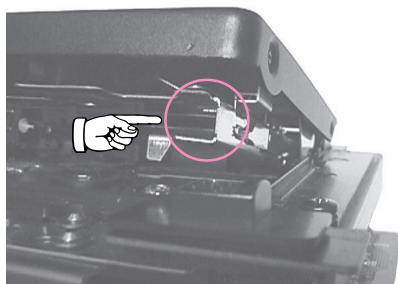

<Fig.24 Position of the hook>

19) Reconnect cables as shown in Fig.20.

19) 図20に示す様に配線します。

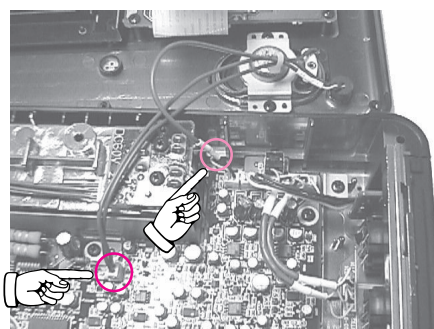

<Fig.25 Reconnecting cables>

## 6. WAVEFORMS

### 6. 波形图

QQ10 ①, ② (I, J) (Play Mode)

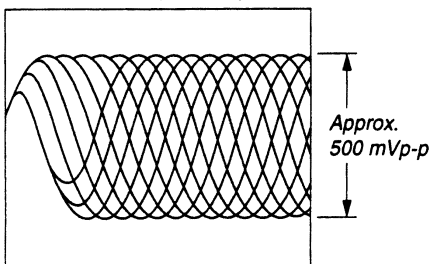

QQ50 ⑩ (FS4)

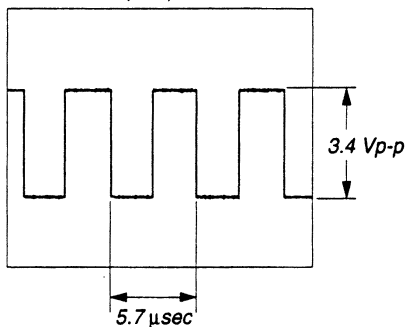

QQ90 (PLAY MODE)

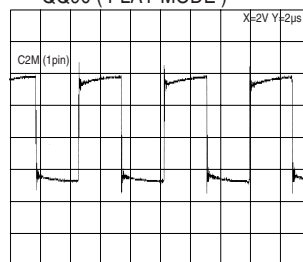

QQ10 ④ (A) (Play Mode)

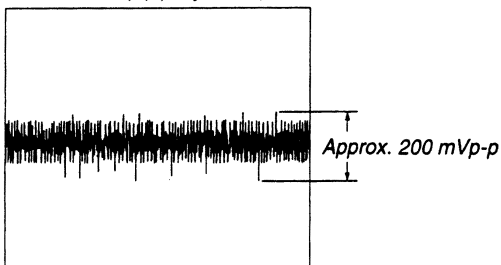

QQ50 ⑬ (OSCI)

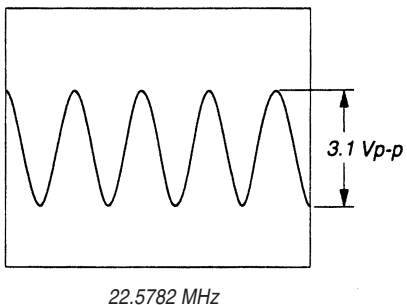

QQ90 (PLAY MODE)

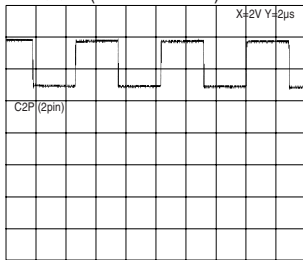

QQ10 ⑧, ⑨ (E, F) (Play Mode)

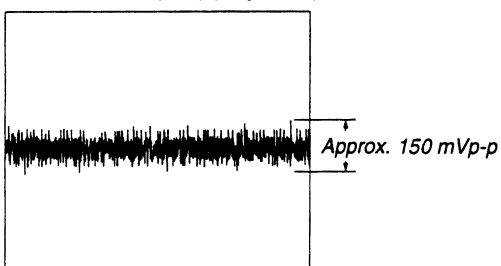

QQ50 ⑲ (LRCK)

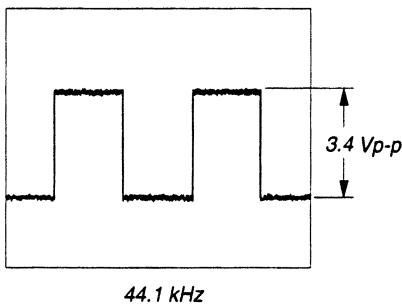

QQ10 ⑳ (RF) (Play Mode)

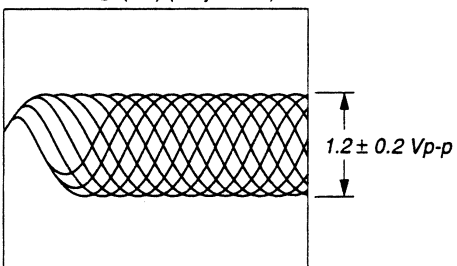

QQ50 ㉑ (XBCK)

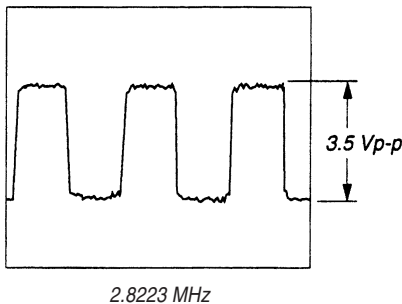

QU01 ㉒ (X1)

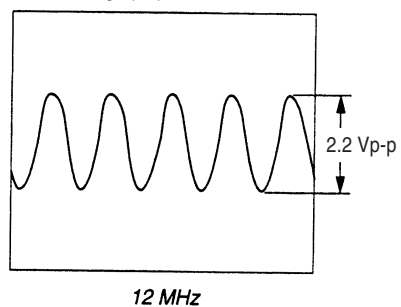

QQ50 ㉓ (FS256)

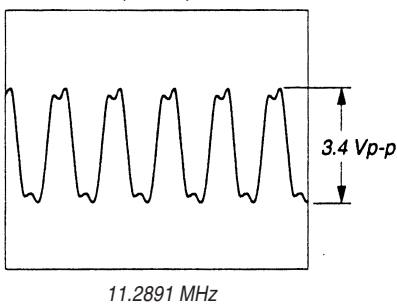

QU01 ㉔ (X2)

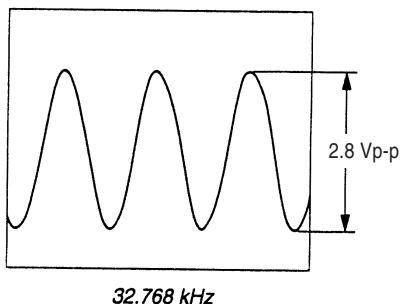

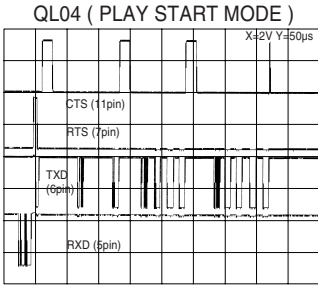
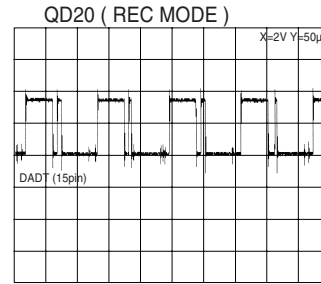
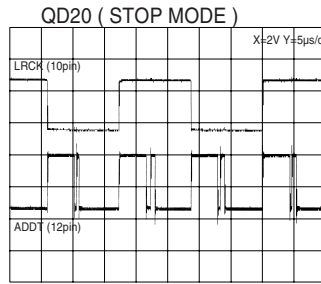
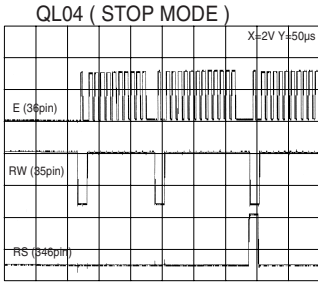

Table 7-1 Symptom and Solution

Symptom	Symptom description	Solution description
Phantom *1	Phantom Power line (+48V) will be shut down when press the <b>PLAY button while RECORDING.</b> 録音中にPLAY ボタンを押すとPhantom 電源 (+48V) が切れる。	Remove the transistor QP33 (PCB PK01). QP33(PCB PK01) 削除する。
REC DATE *2	Recorded DATE/TIME data by PMD650 has no compatibility with other MD recorders. PMD650 で録音後、録音日付表示のある他社製MD プレーヤーで再生すると記録時間が正確に表示されない。	Replace microprocessors QU01 (PCB PQ01) and QL04 (PCB PK01) to latest version ones. 2 つのマイコンQU01 (PCB PQ01) と QL04(PCB PK01) を最新のバージョンに交換する。
MONO/ST sel. *3	MONO/ST (at the STOP mode) switch will not work correctly while LP recording. STOP 時にSOURCE 切り替えSW を切り替えた後、録音をすると正常に録音できない。	Replace microprocessor QL04 (PCB PK01) to latest version one. マイコンQL04(PCB PK01) を最新のバージョンに交換する。
80 min MD *4	Time indication can be shown only 160min while LP mode recording with 80min MD disc. 80分 Disc のLP 録音時に160分を超えた場合、表示が0から始まる。	Replace microprocessors QU01 (PCB PQ01) and QL04 (PCB PK01) to latest version ones. 2 つのマイコンQU01 (PCB PQ01) と QL04(PCB PK01) を最新のバージョンに交換する。
P-ON No read *5	Disc detect will not work. Disc が読み込めず No read の表示をする場合がある。	Short soldering pins (pin33 and pin34) of microprocessor QU01. マイコンQU01 (PCB PQ01) のPin33 とPin34 をショートさせる。

## 7. BUGS AND PROBLEMS

When the symptoms appear as shown in the Table 7-1, solve by referring to Table 7-1, Table 7-2 and Table 7-3. Other symptoms caused by  $\mu$ -processors (QU01, QL04) will be published via "Service Bulletin".

### 7. 不具合対応

下記のTable 7-1のような不具合があった場合には、Table 7-1、Table 7-2、Table 7-3を参考に対応してください。Table 7-3に記載されていないService code 及びLOTの不具合については、今後発行されるサービスブリティンを参照して下さい。

Table 7-2  $\mu$ -processor

MD (QU01)	S20	First version	1stバージョン
		For solution of 80min MD disc time indication : pairing with Main microprocessor V57 or later is necessary.	80分 Disc 表示対応版: V57 以降のメインマイコンとの組み合わせが必須
HU409ST00F	S22	For solution of REC date/time compatibility with other MD recorder : pairing with Main microprocessor V58 or later is necessary.	F 向けのみ初LOT (07) からの対応: REC DATE 互換性対応版
	S23		
Main (QL04)	V54	First version	1stバージョン
	V55	For solution of MONO/STEREO selector problem	MONO/ST sel.修正
HU409ST10F	V57	For solution of 80min MD disc time indication : pairing with MD microprocessor S22 or later is necessary.	80分 Disc 対応版: S22 以降のMD マイコンとの組み合わせが必須 HU409ST10F
	V58	For solution of REC date/time compatibility with other MD recorder : pairing with Main microprocessor S23 or later is necessary.	S23 と併にバージョン表示修正

Table 7-3 Service cord and Lot

SERVICE CODE	LOT	Version	Quantity	$\mu$ -Processor version		Symptom				
				MD (QU01)	Main (QL04)	Phantom *1	REC DATE *2	MONO/ST sel. *3	80min MD *4	P-ON No read *5
02	02	U	200	S20	V55	OK	NG	OK	NG	OK
00	03	N	200	S20	V54	NG	NG	NG	NG	NG
00	04	N	200	S20	V54	NG	NG	NG	NG	NG
00		N	100	S20	V54	OK	NG	NG	NG	OK
02		N	115	S20	V55	NG	NG	OK	NG	NG
02		N	35	S20	V55	OK	NG	OK	NG	OK
02		N	200	S20	V55	OK	NG	OK	NG	OK
02		U	100	S20	V55	OK	NG	OK	NG	OK
03		N	300	S22	V57	OK	NG	OK	OK	OK
03		U	100	S22	V57	OK	NG	OK	OK	OK
04		F	100	S23	V58	OK	OK	OK	OK	OK
04		F	100	S23	V58	OK	OK	OK	OK	OK
05		N	160	S24	V59	OK	OK	OK	OK	OK
03		U	200	S22	V57	OK	NG	OK	OK	OK
04		N	250	S23	V58	OK	OK	OK	OK	OK
04		U	100	S24	V59	OK	OK	OK	OK	OK
04		F	100	S23	V58	OK	OK	OK	OK	OK
05				S24	V59					

8. WIRING DIAGRAM

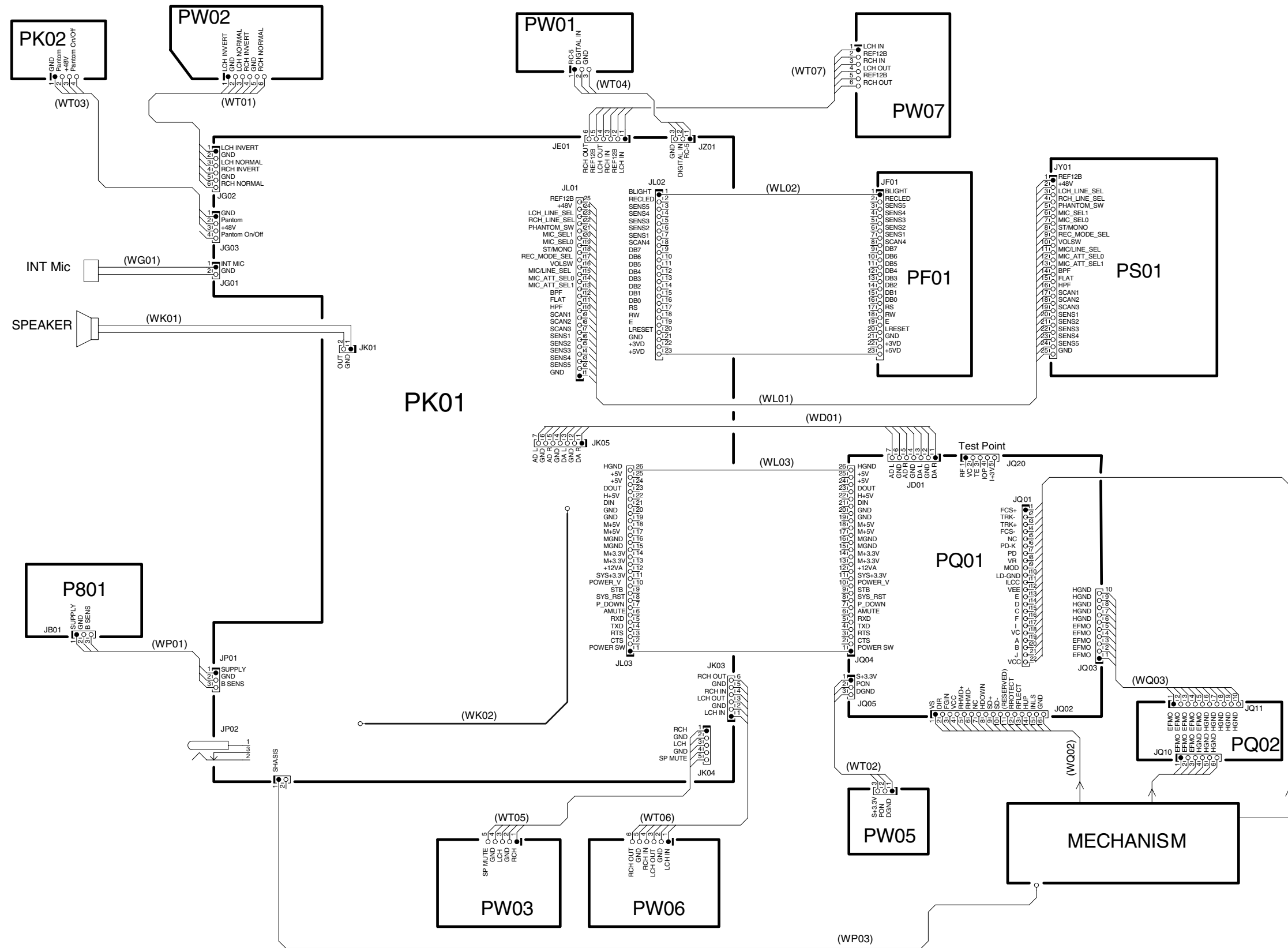

9. BLOCK DIAGRAM

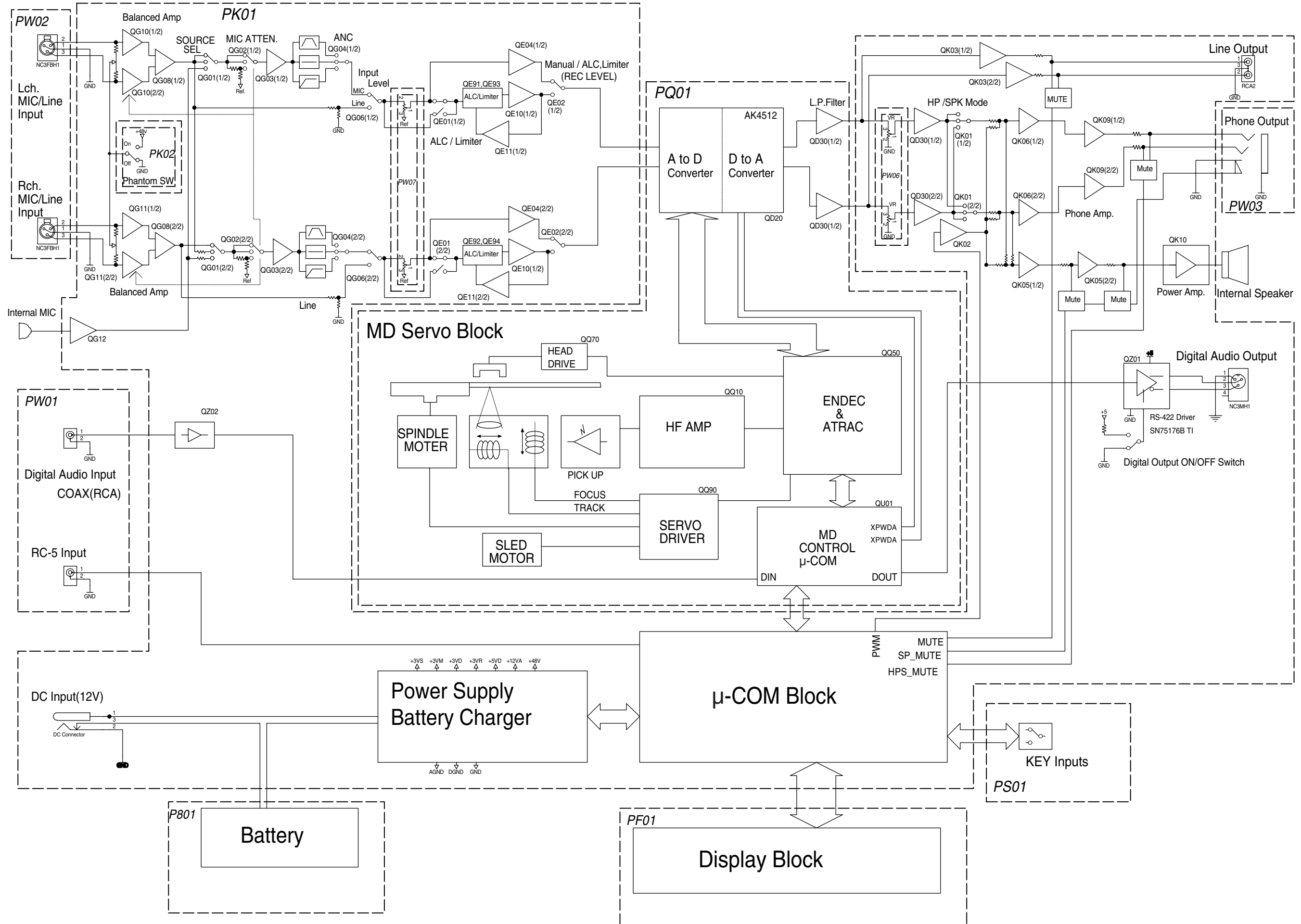

# 10. LEVEL DIAGRAM

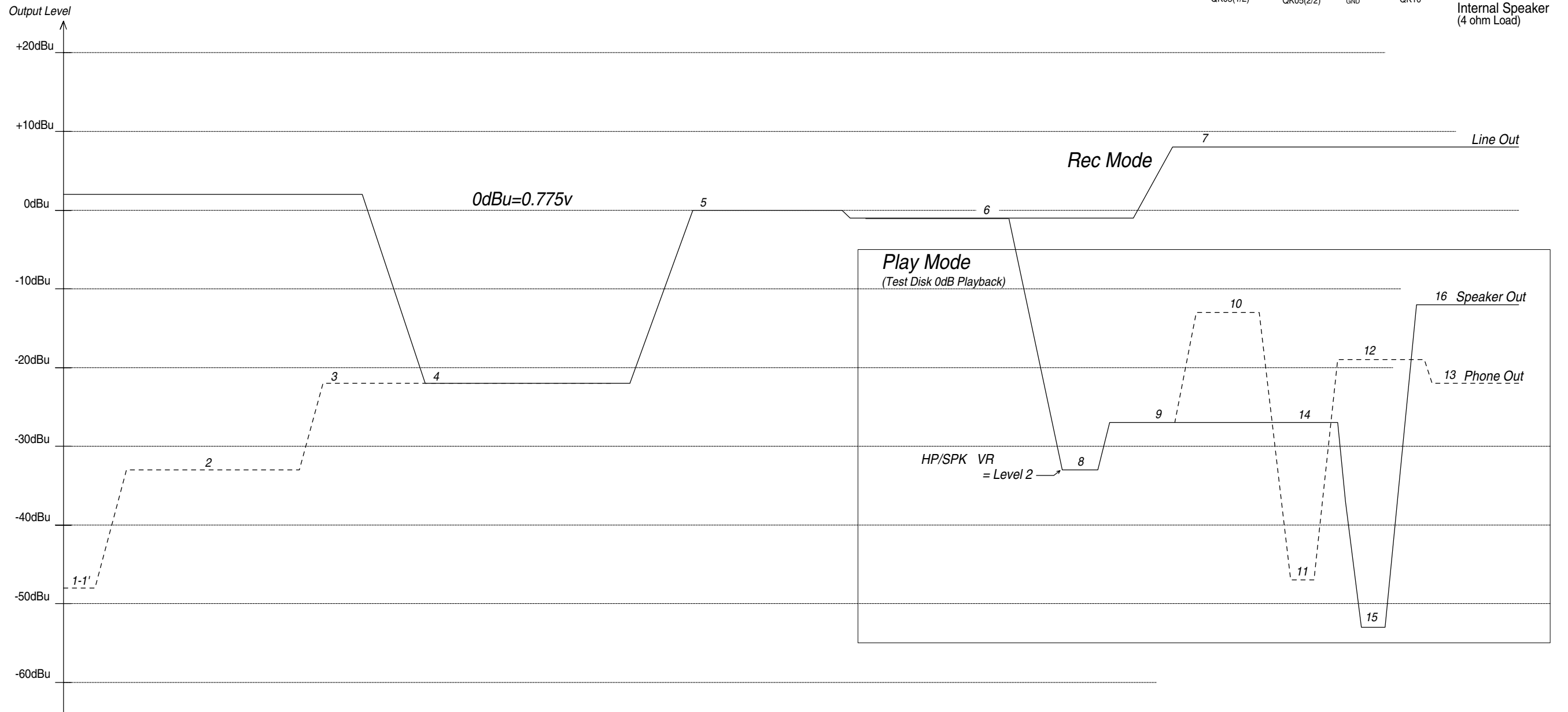
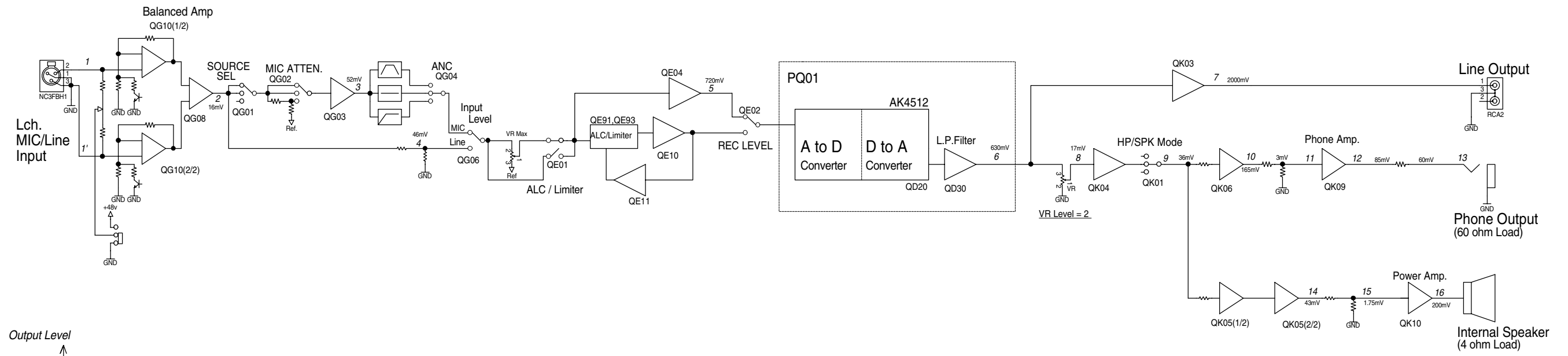

11. SCHEMATIC DIAGRAM

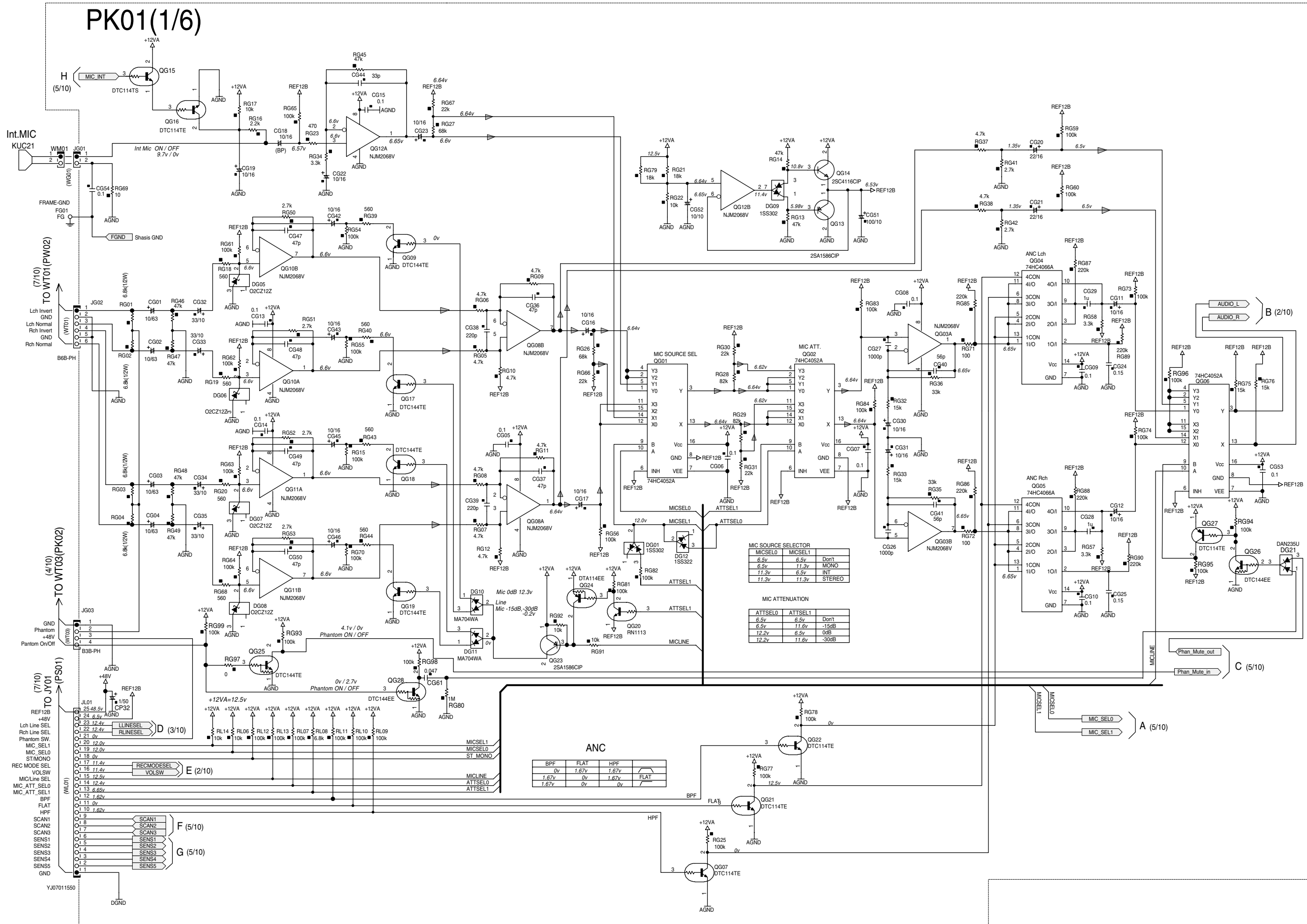



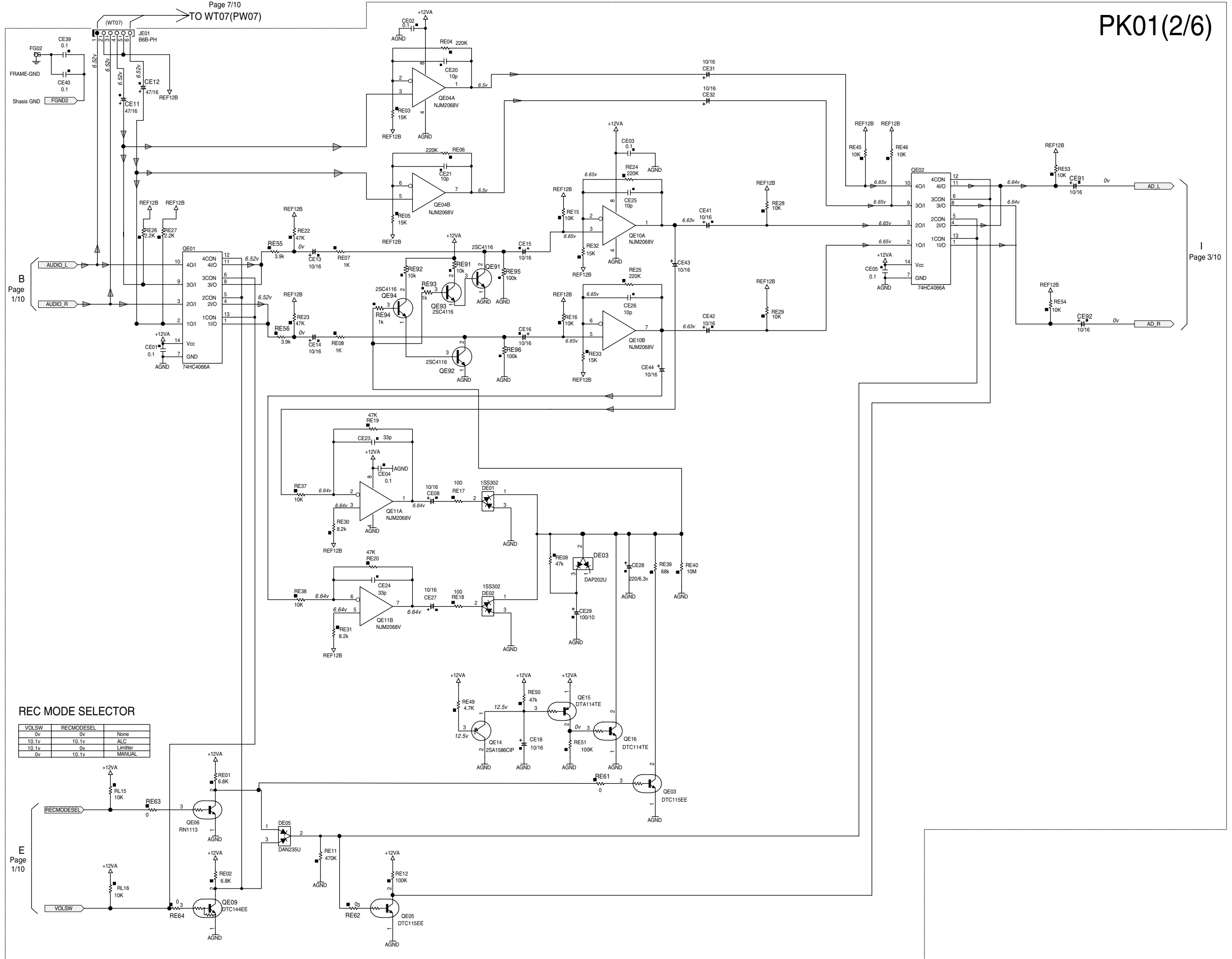

B  
Page 1/10

I  
Page 3/10

REC MODE SELECTOR

VOLSW	RECMODESEL	None
0v	0v	None
10.1v	10.1v	ALC
10.1v	0v	Limiter
0v	10.1v	MANUAL

E  
Page 1/10

# PK01(3/6)

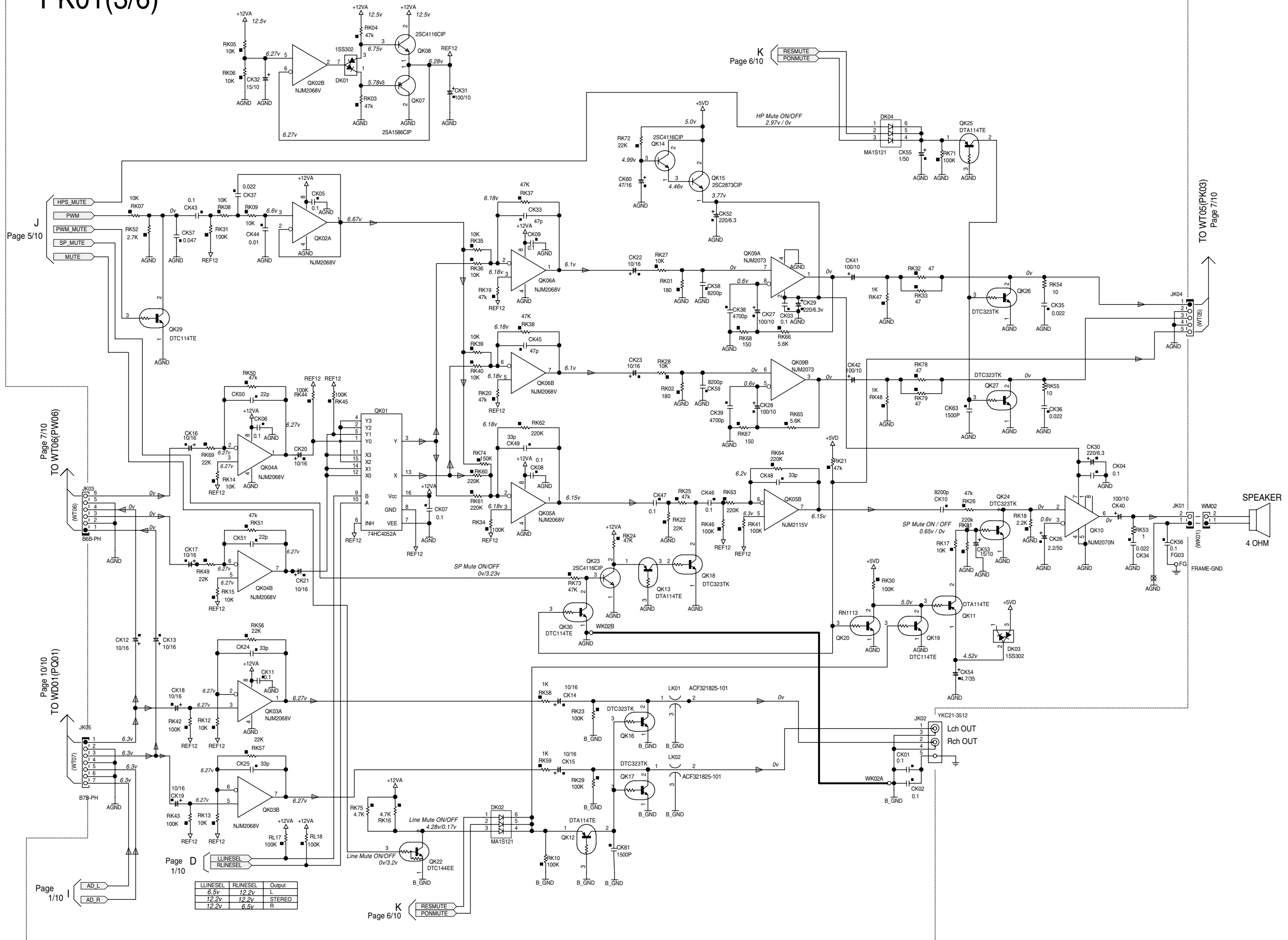

Page D 1/10

LLINESEL	RLINESEL	Output
6.5v	12.2v	L
12.2v	12.2v	STEREO
12.2v	6.5v	R

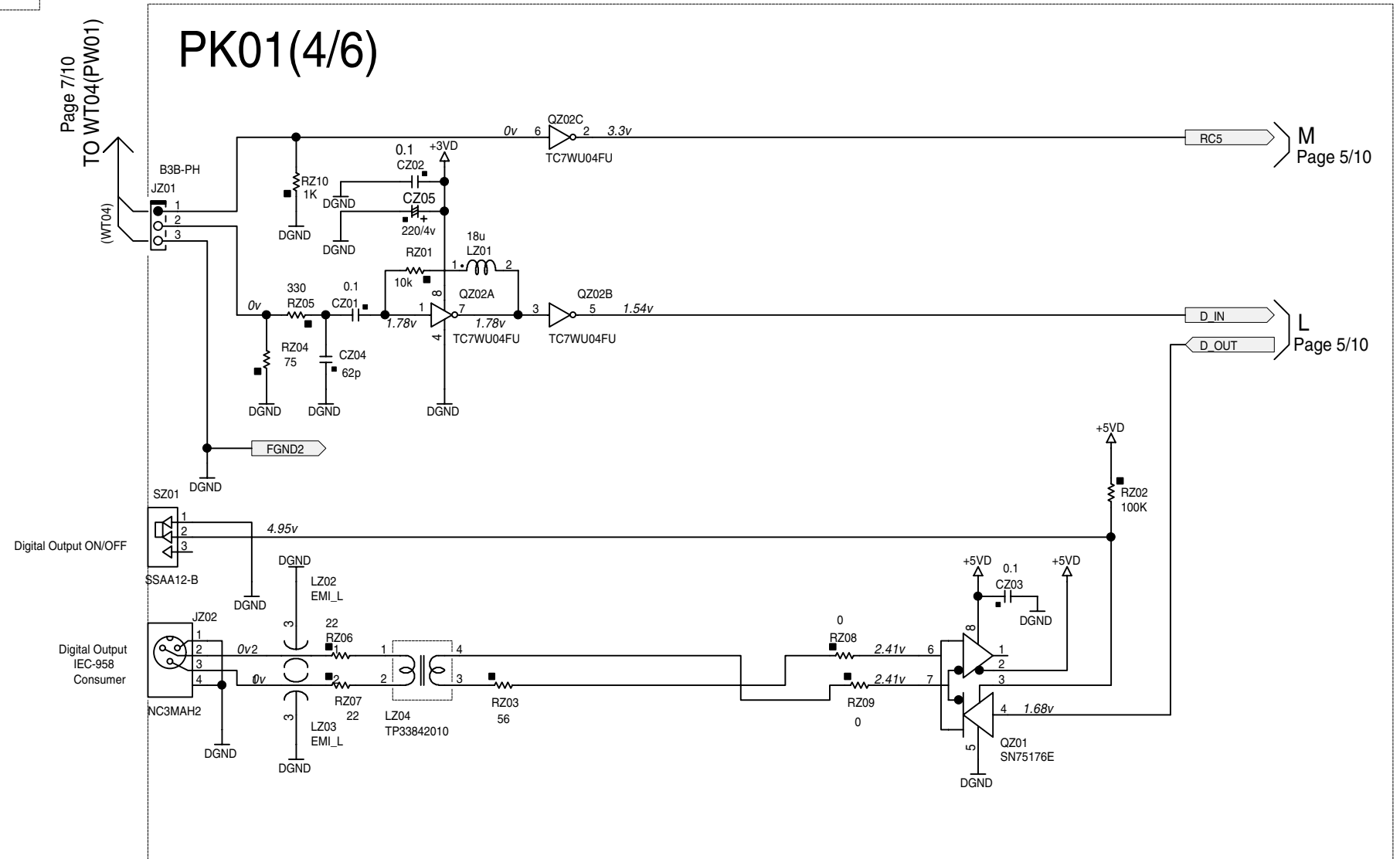
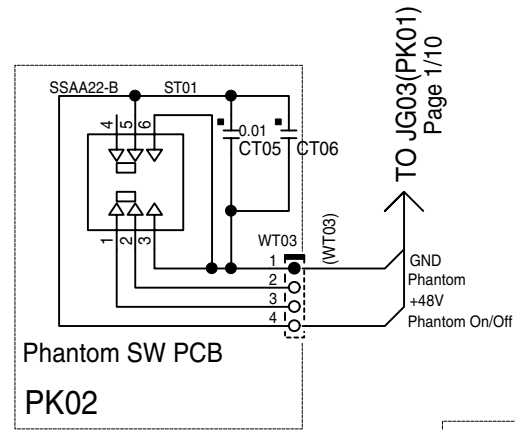

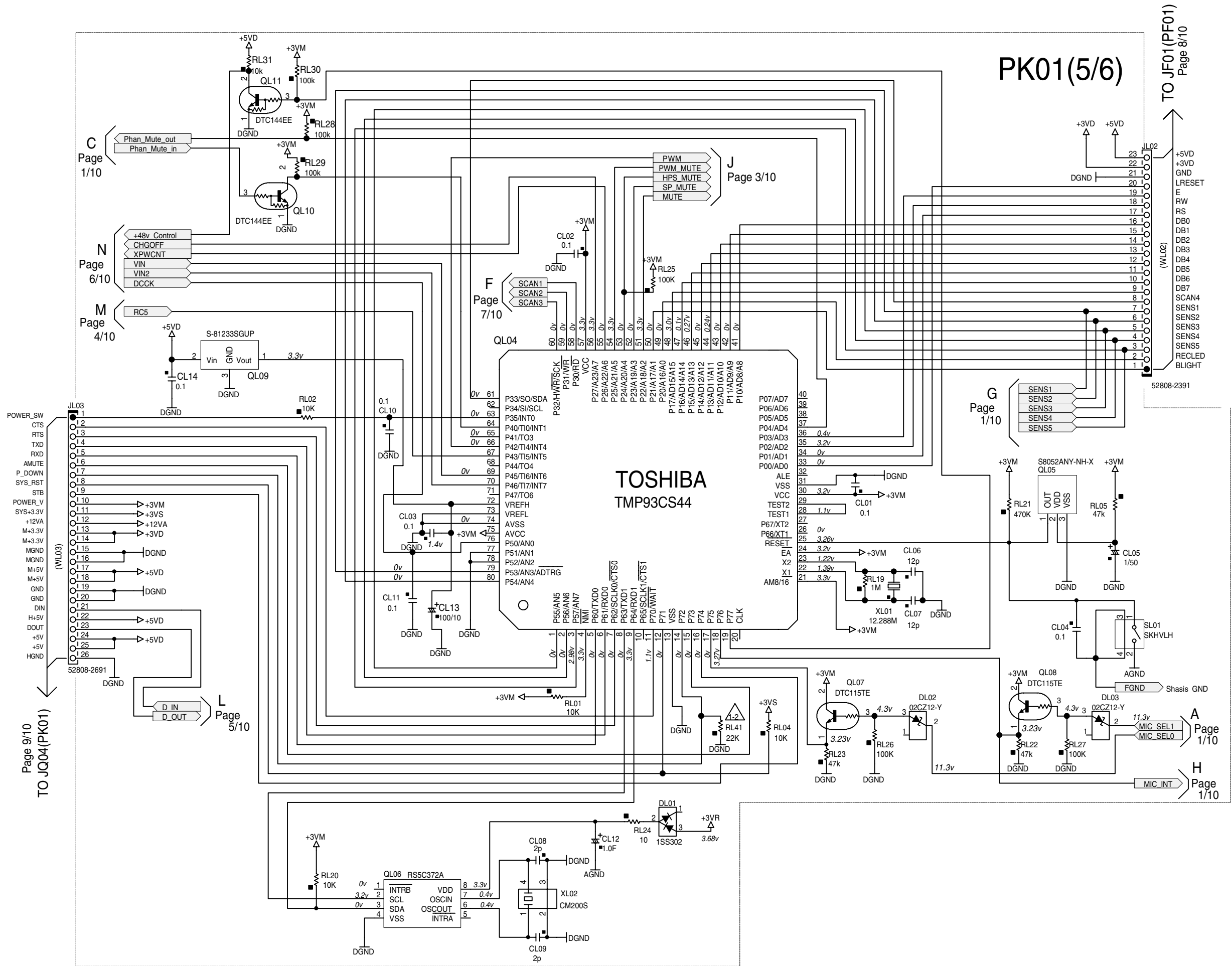

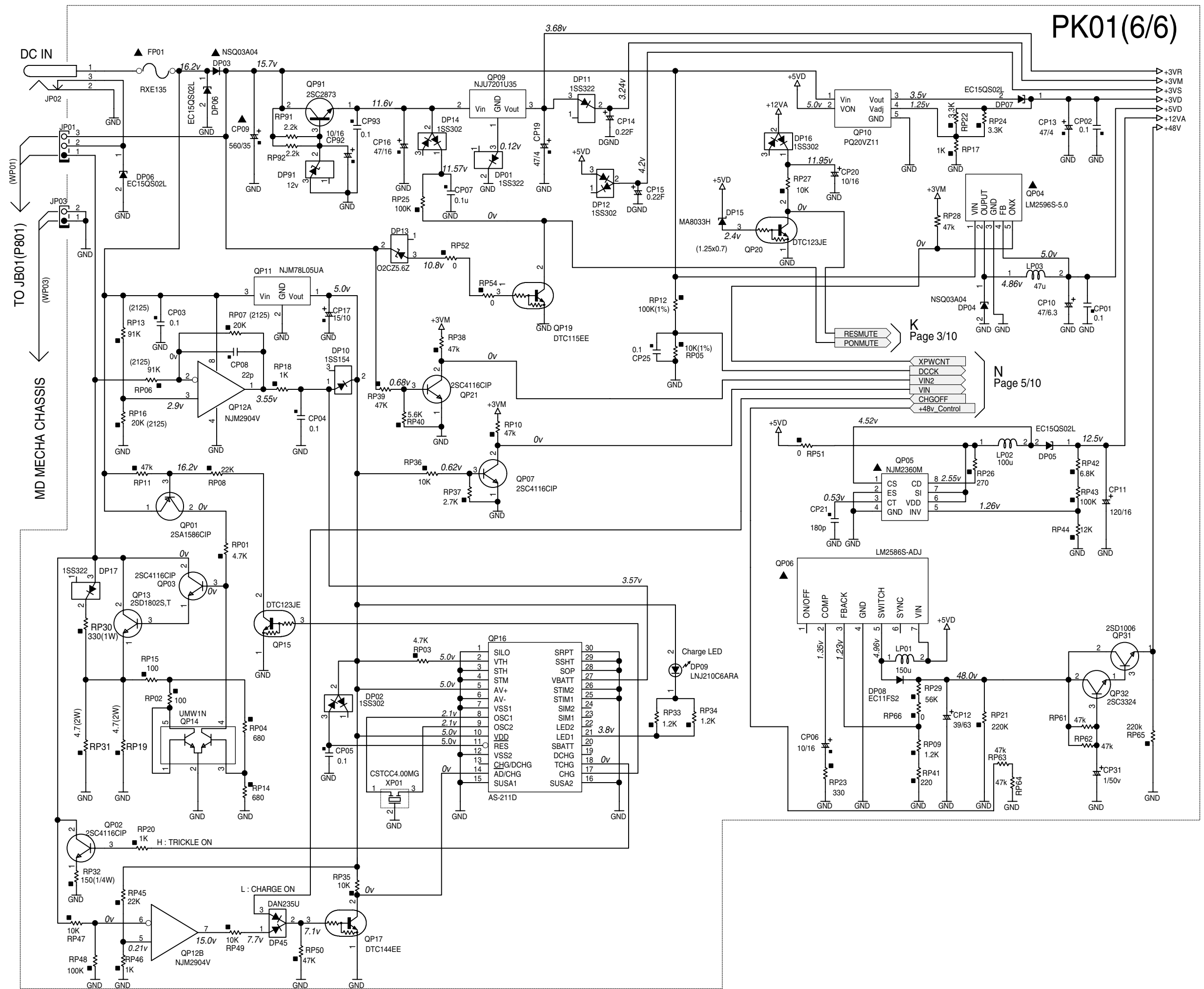

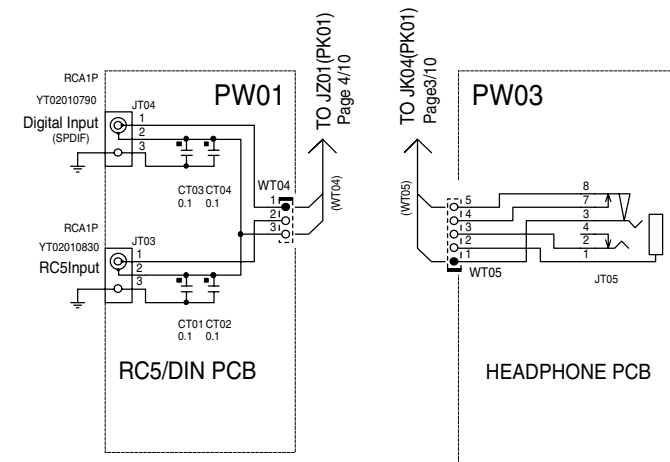
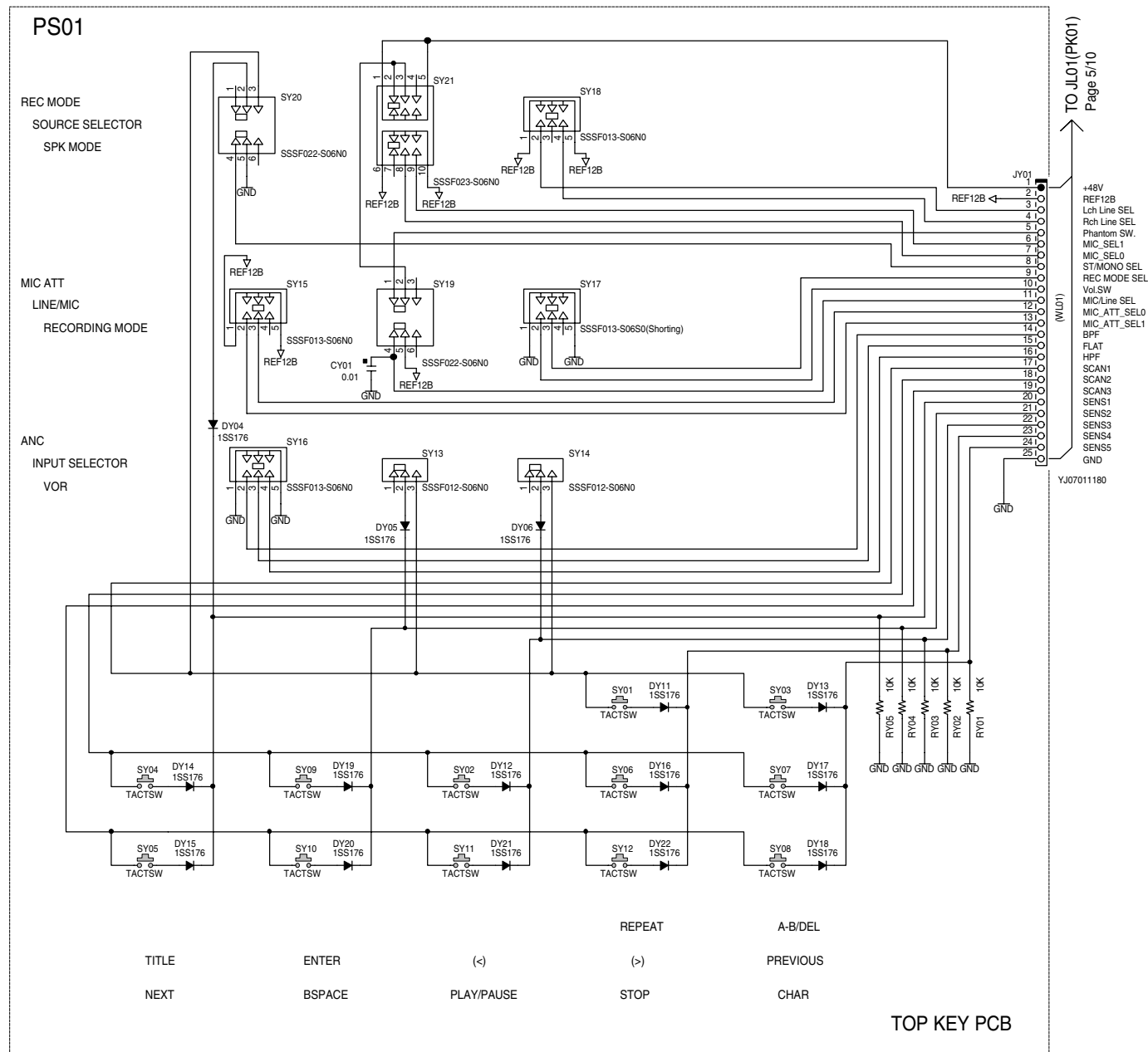
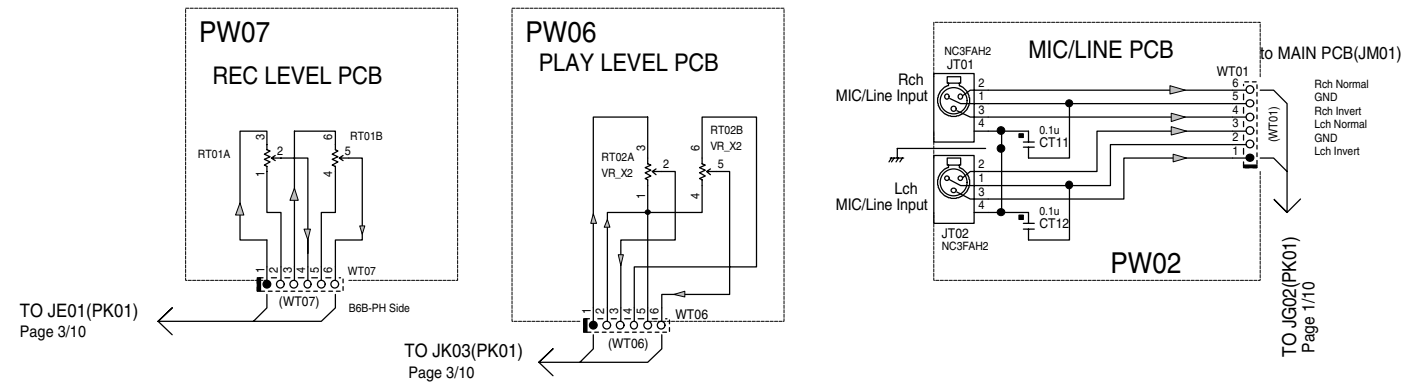

# PF01

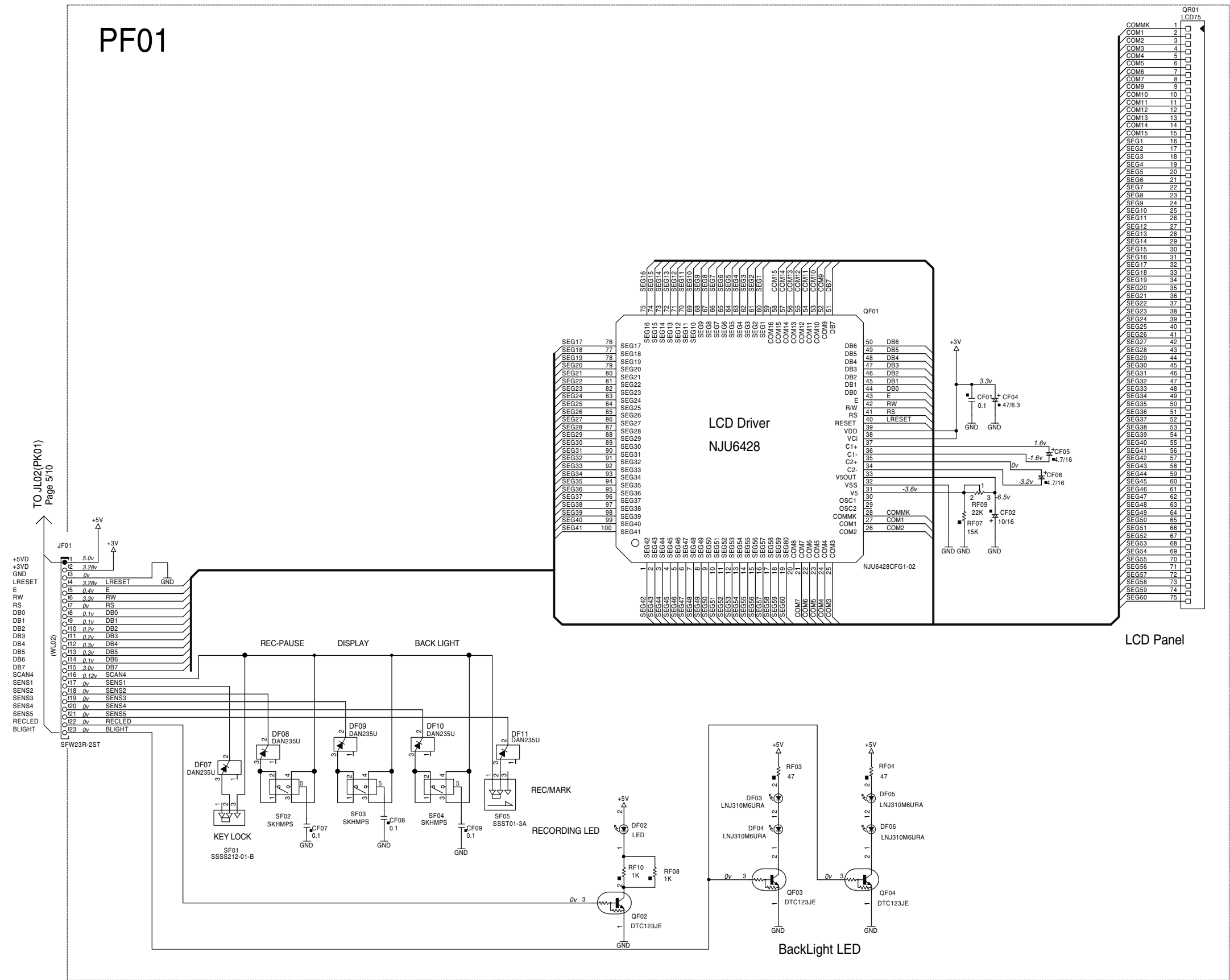

TO JL02(PK01)  
Page 5/10

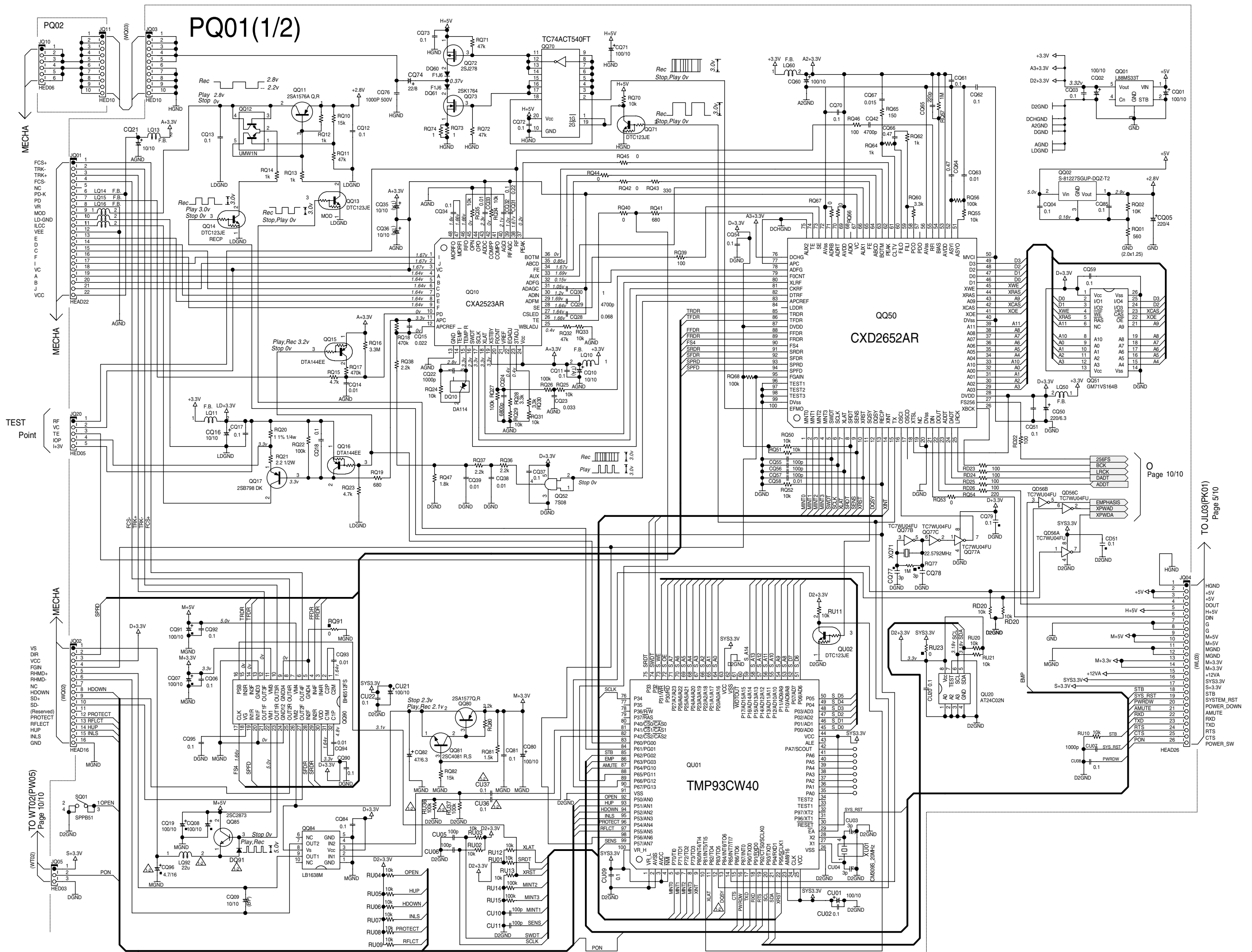



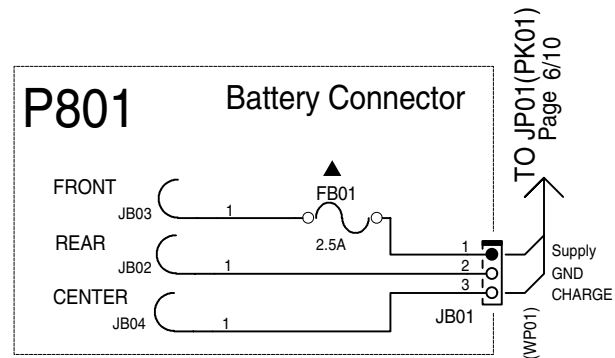
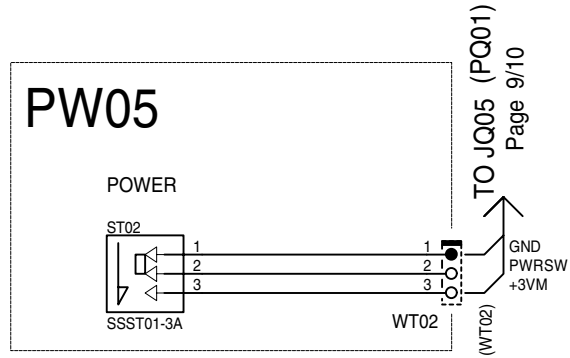
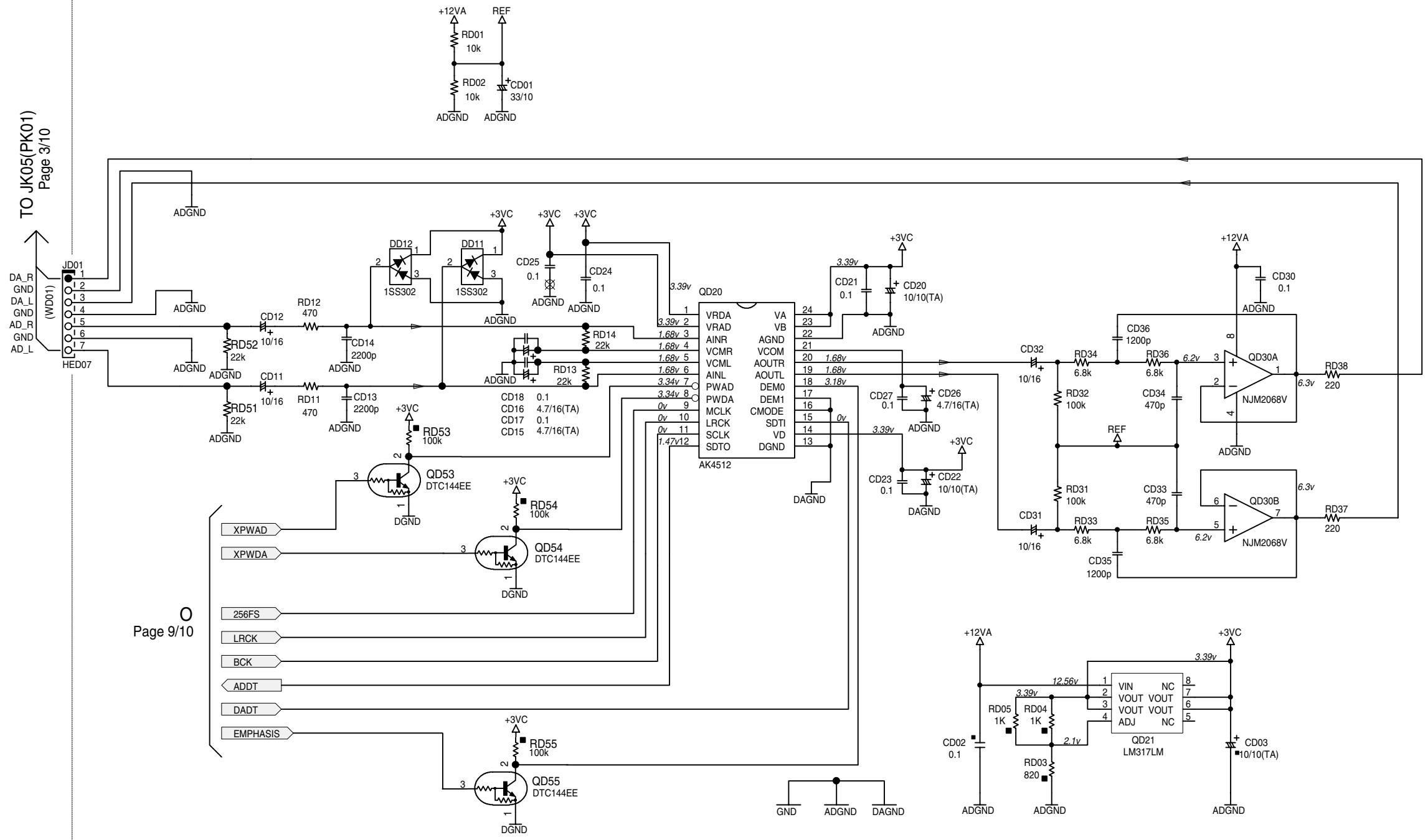

## 12. PARTS LOCATION

**PW01**

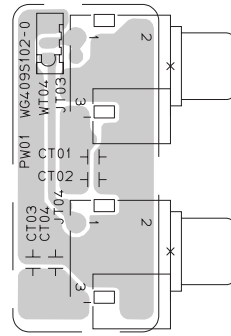

**PW02**

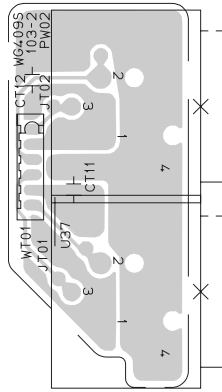

**PW03**

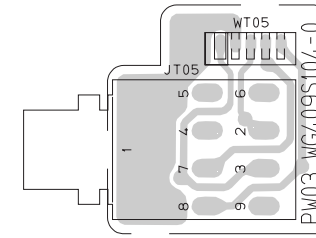

**PW06**

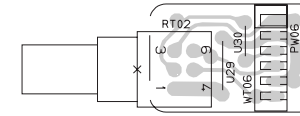

**PS01**

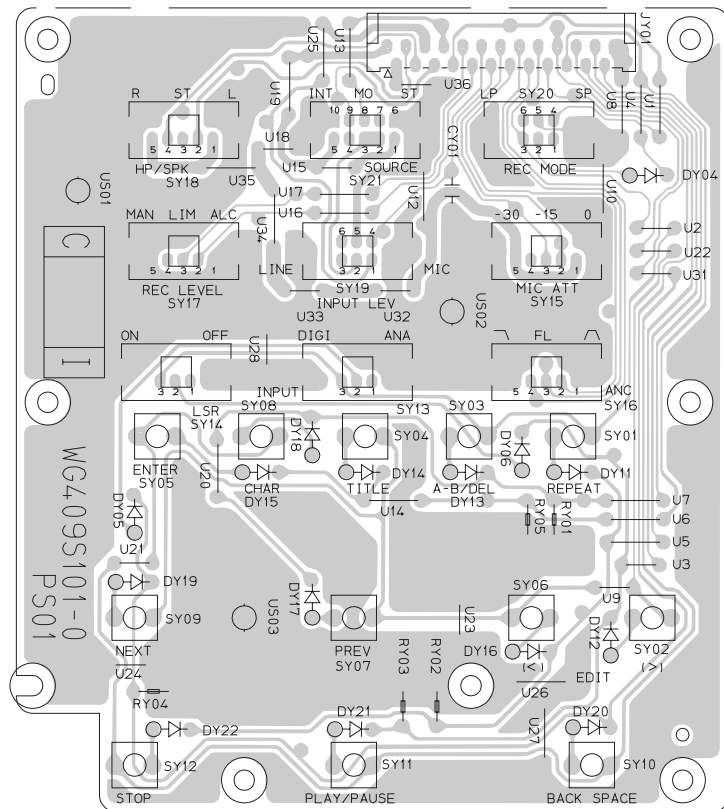

**PW07**

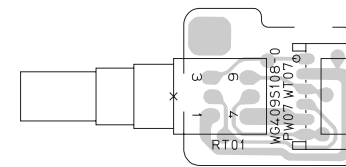

**PK01:**

QE01	D7	QL04	E7
QE02	D6	QL05	F8
QE03	C7	QL06	F8
QE04	D6	QL07	E8
QE05	D7	QL08	E8
QE06	D7	QL09	F6
QE09	D7	QL10	E6
QE10	C6	QL11	F6
QE11	C7		
QE14	C6	QP01	C5
QE15	C6	QP02	D3
QE16	C6	QP03	C4
QE91	C7	QP04	C3
QE92	C7	QP05	C4
QE93	C7	QP06	C5
QE94	C7	QP07	D3
		QP08	C5
QG01	D9	QP09	B2
QG02	D9	QP10	B2
QG03	D9	QP11	D3
QG04	E9	QP12	D3
QG05	E8	QP13	C4
QG06	D8	QP14	C4
QG07	E8	QP15	C5
QG08	C8	QP16	D5
QG09	B8	QP17	D5
QG10	B8	QP18	B1
QG11	B9	QP19	B1
QG12	C9	QP20	C3
QG13	C9	QP21	C2
QG14	C8	QP31	C6
QG15	B8	QP32	C6
QG16	A8	QP33	C5
QG17	C8	QP91	B2
QG18	C9		
QG19	C8	QZ01	E2
QG20	C8	QZ02	F9
QG21	E8		
QG22	E8		
QG23	C8		
QG24	C8		
QG25	B8		
QG26	D8		
QG27	D8		
QG28	C8		
QK01	E5		
QK02	F4		
QK03	E6		
QK04	E5		
QK05	E5		
QK06	E5		
QK07	E4		
QK08	E4		
QK09	E3		
QK10	E4		
QK11	E4		
QK12	D2		
QK13	F5		
QK14	E3		
QK15	E3		
QK16	D2		
QK17	D2		
QK18	F5		
QK19	E4		
QK20	E4		
QK22	D1		
QK23	F5		
QK24	E4		
QK25	F3		
QK26	F2		
QK27	F3		
QK29	E5		
QK30	F5		

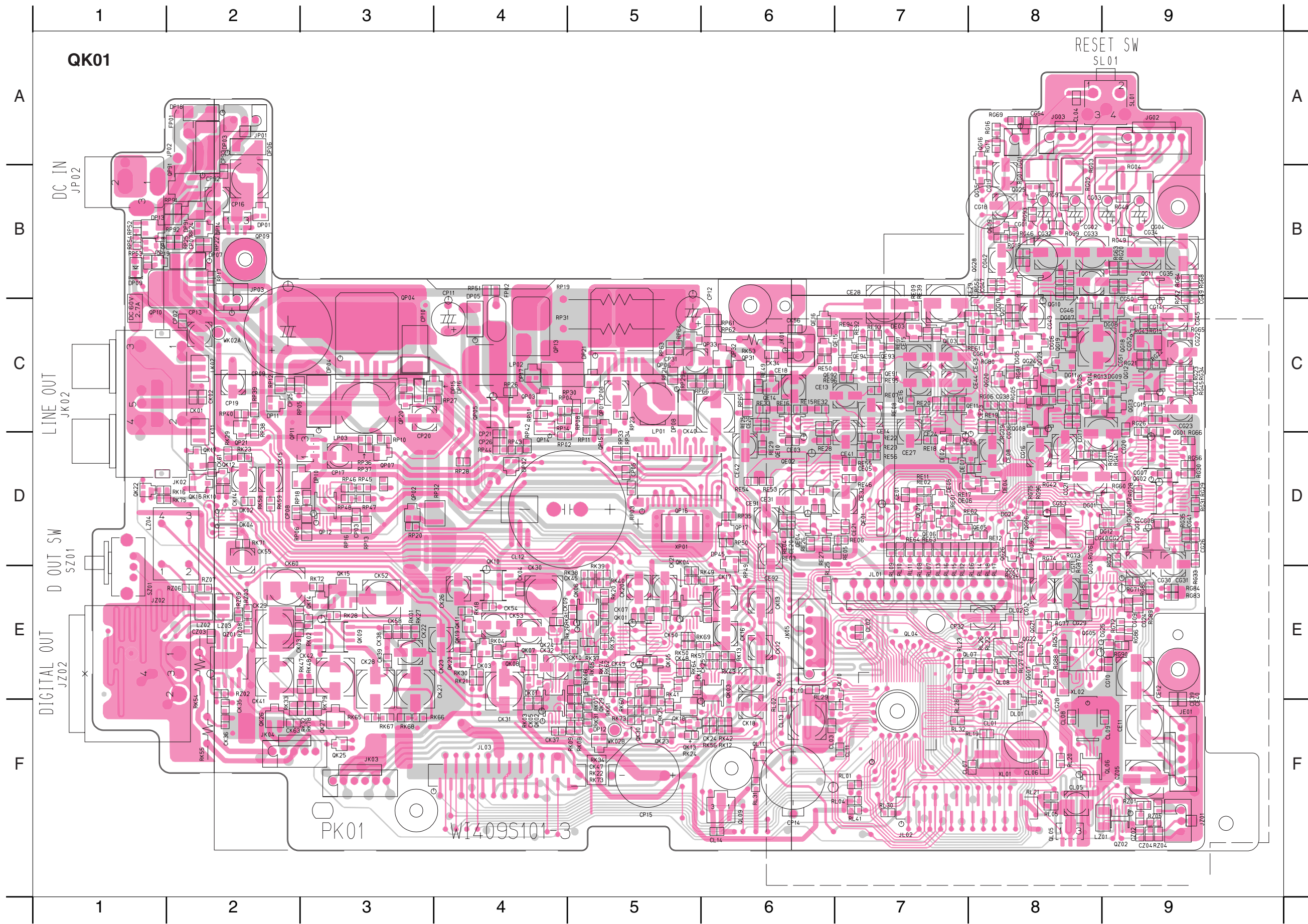

**PK02**

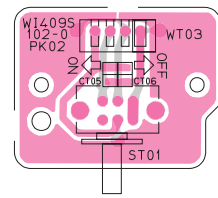

**P801**

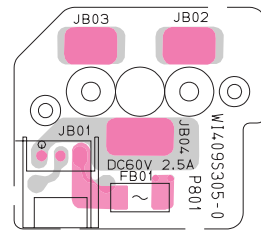

**PQ02**

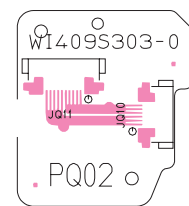

**PW05**

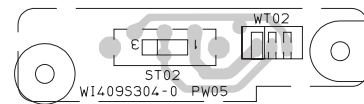

**PF01**

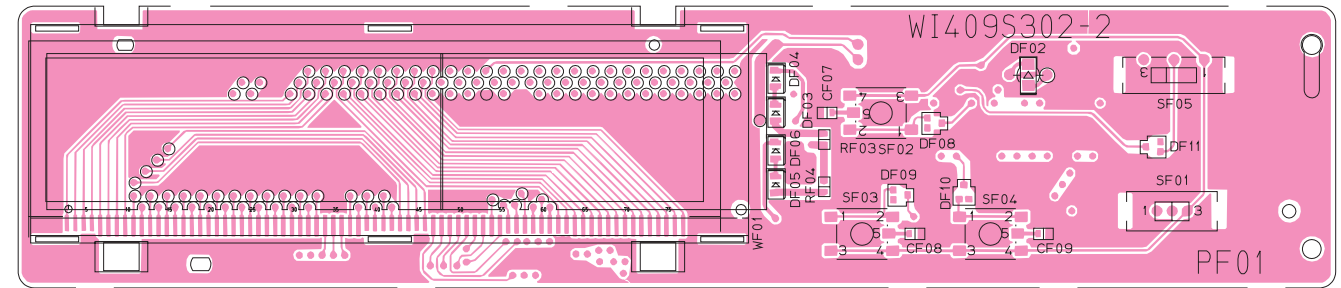

**PF01**

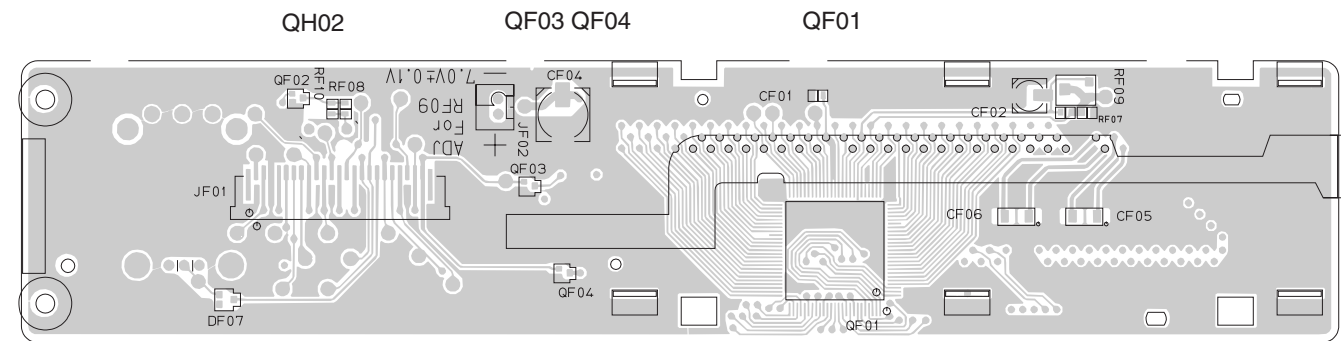

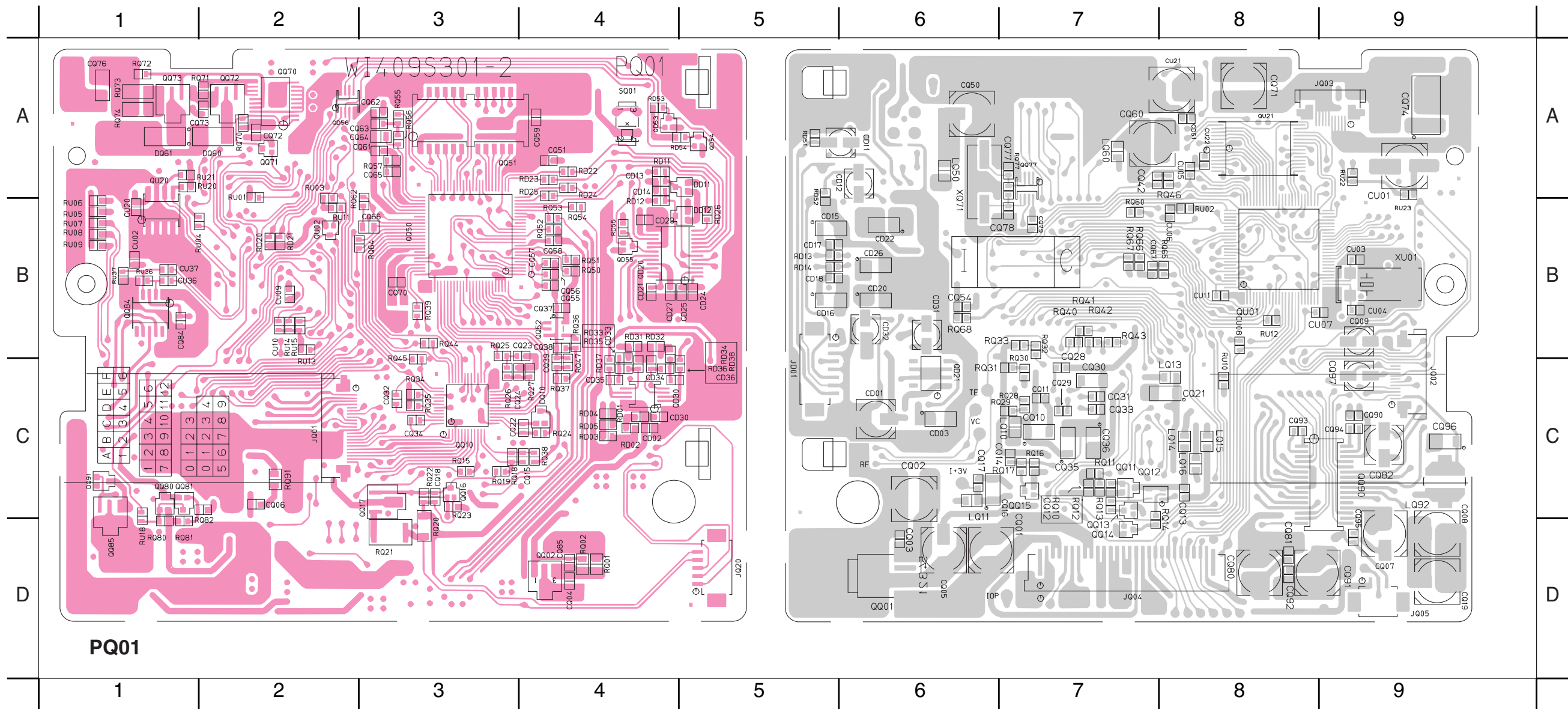

QD20 B4	QQ50 B3
QD21 C6	QQ51 A3
QD53 A4	QQ52 B4
QD54 A5	QQ71 A2
QD55 B4	QQ72 A2
QD56 A2	QQ73 A1
	QQ77 A7
QQ01 D6	QQ80 C1
QQ02 D4	QQ81 C1
QQ10 C3	QQ84 B1
QQ11 C7	QQ85 C1
QQ12 C7	QQ90 C9
QQ13 C7	
QQ14 D7	QU01 B8
QQ15 C7	QU02 B2
QQ16 C3	QU20 B1
QQ17 C3	QU21 A8

### 13. MICROPROCESSOR C DATA

QE01 : TC74HC4066AFT

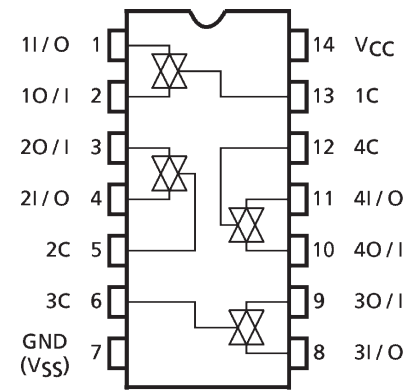

CONTROL	SWITCH FUNCTION
H	ON
L	OFF

QK10 : NJM2070

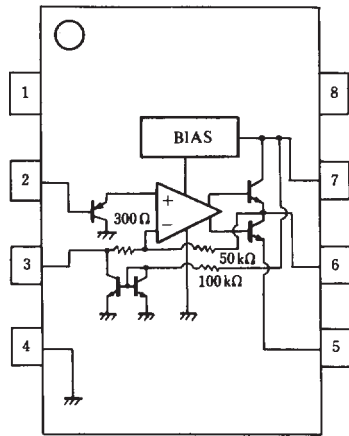

PIN FUNCTION  
 1. NC  
 2. +INPUT  
 3. -INPUT  
 4. GND  
 5. GND  
 6. OUTPUT  
 7. V+  
 8. NC

QQ70 : TC74ACT540

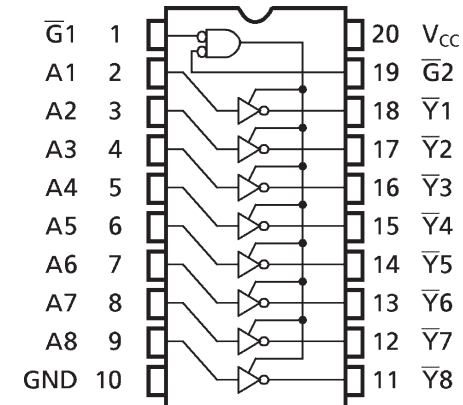

QF01 : NJU642806

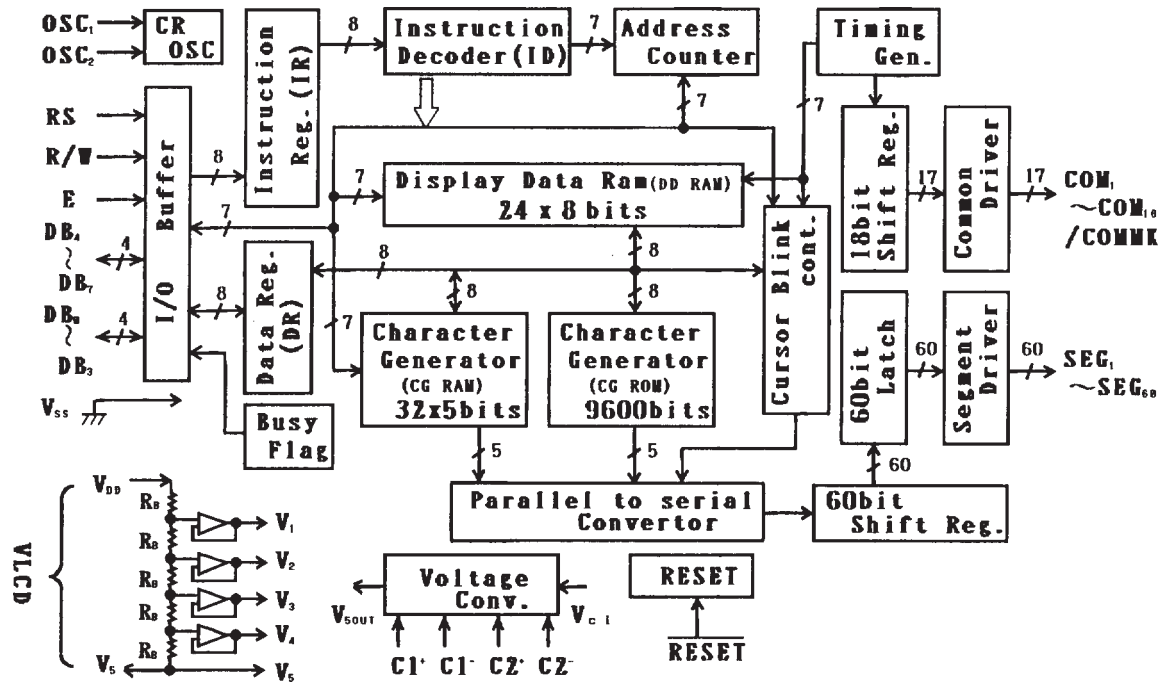

QG01 : TC74HC4052AF

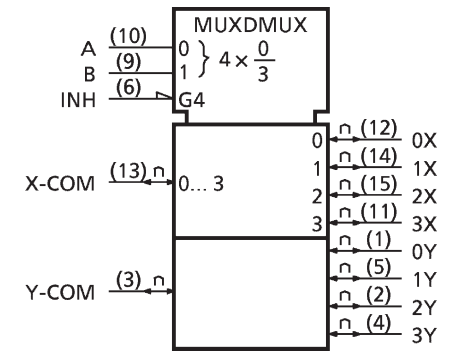

CONTROL INPUTS				"ON" CHANNEL		
INHIBIT	C*	B	A	HC4051A	HC4052A	HC4053A
L	L	L	L	0	0X, 0Y	0X, 0Y, 0Z
L	L	L	H	1	1X, 1Y	1X, 0Y, 0Z
L	L	H	L	2	2X, 2Y	0X, 1Y, 0Z
L	L	H	H	3	3X, 3Y	1X, 1Y, 0Z
L	H	L	L	4	--	0X, 0Y, 1Z
L	H	L	H	5	--	1X, 0Y, 1Z
L	H	H	L	6	--	0X, 1Y, 1Z
L	H	H	H	7	--	1X, 1Y, 1Z
H	X	X	X	NONE	NONE	NONE

X: Don't Care, \*: Except HC4052A

QP05 : NJM2360

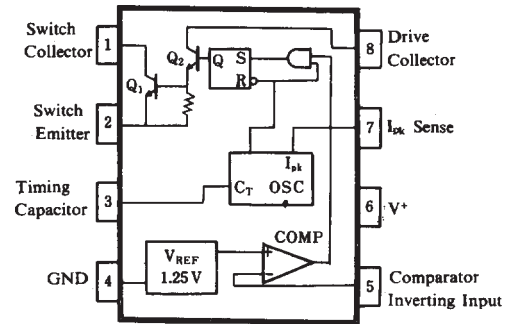

QQ50 : CXD2652AR

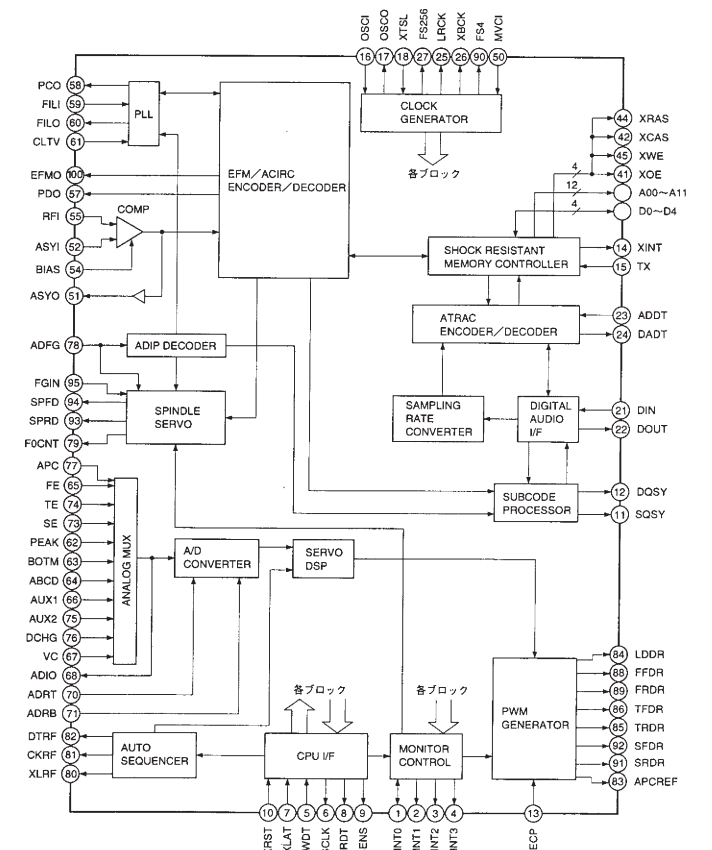

QP16 : AS-211D

No.	名称	I/O	回路種類	端子機能
1	SILO	I	A	初期タイマ時間設定
2	VTH	I	A	Voltage Thermistor
3	STH	I	A	Set Thermistor Hll Level
4	STM	I	A	Set Thermistor Middle Level
5	AV*	—	—	A/D Converter Reference
6	AV	—	—	Voltage Input
7	VSS1	—	—	グラウンド
8	OSC1	I	—	External Ceramic
9	OSC2	O	—	Resonator Connection
10	VDD	—	—	SV Supply
11	RSS	I	—	System Reset Input Normally High
12	VSS2	—	—	グラウンド
13	CHG/DCIG	I	B	Charge / Discharge Select
14	AD/CHG	I	B	Adapter / Charge Select
15	SUSA1	I	B	Select Usage 1
16	SUSA2	I	B	Select Usage 2
17	CHG	O	D	Charge Control
18	TRCHG	O	D	Trickle Charge Control
19	DCIG	O	D	Discharge Control
20	SBATT	O	D	Select Battery ( NiCd / NiMH )
21	LED1	O	C	LED1
22	LED2	O	C	LED2
23	SM1	I	B	Select Indication Mode 1
24	SM2	I	B	Select Indication Mode 2
25	STIM1	I	B	Select Timer 1
26	STIM2	I	B	Select Timer 2
27	VBATT	I	A	Voltage Battery
28	SOP	I	A	Set Open Battery Voltage
29	SSH	I	A	Set Short Battery Voltage
30	SRT	I	A	Set Report Charge Voltage

QQ10 : CXA2523AR

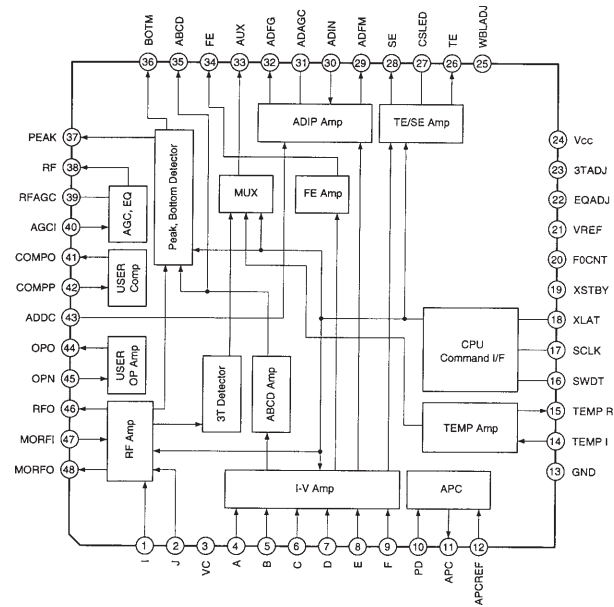

**QL06 : RS5C372A**

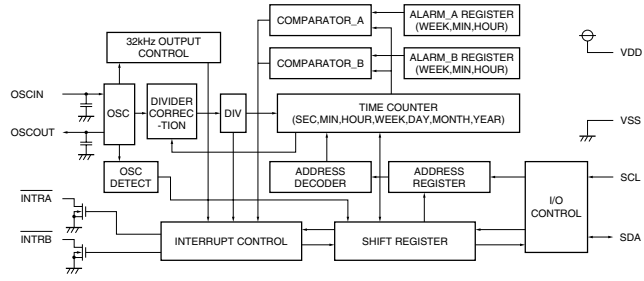

**QP06 : LM2586**

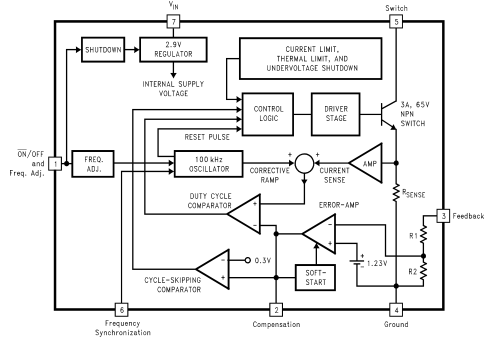

**QQ84 : LB1638M**

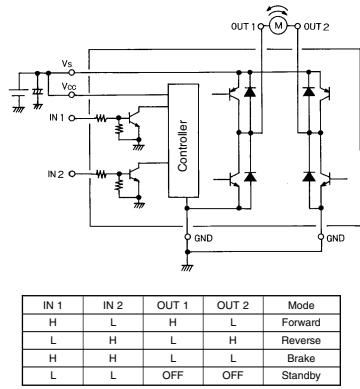

**QQ90 : BH6512FS**

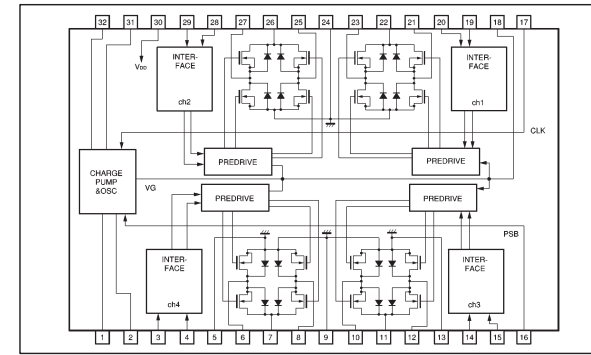

Pin No.	Pin name	Function	Pin No.	Pin name	Function
1	C2M	Negative connection pin for charge pump capacitor 2	17	CLK	Synchronous clock input
2	C2P	Positive connection pin for charge pump capacitor 2	18	VG	Charge pump output
3	IN4R	Channel 4 reverse input	19	IN1R	Channel 1 reverse input
4	IN4F	Channel 4 forward input	20	IN1F	Channel 1 forward input
5	GND4	Channel 4 GND and pre block GND	21	OUT1R	Channel 1 reverse output
6	OUT4F	Channel 4 forward output	24	GND12	Channels 1 and 2 power GND
7	VM4	Channel 4 power block power supply	25	OUT2R	Channel 2 reverse output
8	OUT4R	Channel 4 reverse output	26	VM2	Channel 2 power block power supply
9	GND34	Channels 3 and 4 power GND	27	OUT2F	Channel 2 forward output
10	OUT3R	Channel 3 reverse output	28	IN2F	Channel 2 forward input
11	VM3	Channel 3 power block power supply	29	IN2R	Channel 2 reverse input
12	OUT3F	Channel 3 forward output	30	VDD	Pre block power supply
13	GND3	Channel 3 power GND	31	C1M	Negative connection pin for charge pump capacitor 1
14	IN3F	Channel 3 forward input	40	P10/AD8/A8	I/O DB0
15	IN3R	Channel 3 reverse input	42	P11/AD9/A9	I/O DB1
16	PSB	Power off	44	P12/AD10/A10	I/O DB2
			46	P13/AD11/A11	I/O DB3
			48	P14/AD12/A12	I/O DB4
			50	P15/AD13/A13	I/O DB5
			52	P16/AD14/A14	I/O DB6
			54	P17/AD15/A15	I/O DB7
			56	P20/A16/A0	OUT RECLE
			58	P21/A17/A1	OUT BKLT
			60	P22/A18/A2	OUT MUTE
			62	P23/A19/A3	OUT SPMUTE
			64	P24/A20/A4	OUT POFMUTE
			66	P25/A21/A5	OUT PMWMUT
			68	P26/A22/A6	OUT XPWCNT
			70	P27/A23/A7	OUT CHGOFF
			72	VCC	VCC Power supply
			74	P30/RDX	OUT KSCAN0
			76	P31/WRX	OUT KSCAN1
			78	P32/HWRX/SCK	OUT KSCAN2
			80	P33/SO/SDA	OUT KSCAN3
			82	P34/SI/SDA	OUT NC
			84	P35/INT0	IN PWRSW
			86	P40/TI0/INT1	OUT NC
			88	P41/TO3	OUT BUZZER
			90	P42/TI4/INT4	IN RC5IN
			92	P43/TI5/INT5	OUT NC
			94	P44/TO4	OUT NC
			96	P45/TI6/INT6	IN VIN
			98	P46/TI7/INT7	IN VIN1
			100	P47/TO6	OUT NC
			102	VREFH	IN +3.3V
			104	VREFL	IN GND
			106	AVSS	GND
			108	AVCC	+3.3V
			110	P50/AN0	IN DCCK
			112	P51/AN1	IN GND
			114	P52/AN2	IN GND
			116	P53/AN3/ADTRGX	IN KSENS0
			118	P54/AN4	IN KSENS1

**QL04 : TMP93S44F**

No.	Pin Name	I/O	Port Name	Remark	PU	ACTIVE	INIT
1	P55/AN5	IN	KSENS2	Key sense	0	HIGH	LOW
2	P56/AN6	IN	KSENS3	Key sense	0	HIGH	LOW
3	P57/AN7	IN	KSENS4	Key sense	0	HIGH	LOW
4	XNMI	IN	XNMI	Fix to VCC	-	-	-
5	P60/TXD0	OUT	TXD	MD u-com serial output line	0	-	-
6	P61/RXD0	IN	RXD	MD u-com serial input line	0	-	-
7	P62/SCLK0/CTS0X	IN	CTS	MD u-com output ACK	0	LOW	HIGH
8	P63/TXD1	OUT	SCL	RTC shift clock	0	LOW	HIGH
9	P64/RXD1	I/O	SDA	RTC serial data line	0	LOW	HIGH
10	P65/SCLK1/CTS1X	OUT	NC	-	x	-	-
11	P70/WAITX	OUT	RTS	MD u-com output request	-	LOW	LOW
12	P71	OUT	SYSRST	MD u-com reset control	-	LOW	LOW
13	VSS	-	GND	GND	-	-	-
14	P72	OUT	PWRDW	MD u-com power down	-	LOW	LOW
15	P73	OUT	NC	AD/DA mute	-	LOW	LOW
16	P74	IN	STB	MD u-com power down ready	0	LOW	HIGH
17	P75	IN	MIC_SEL0	Source SW	0	LOW	-
18	P76	IN	MIC_SEL1	Source SW	0	LOW	-
19	P77	OUT	NC	-	-	-	-
20	CLK	OUT	NC	-	-	-	-
21	AM8/TI6	IN	+3.3V	Fix to VCC	-	-	-
22	X1	IN	X1	12.288MHz	-	-	-
23	X2	OUT	X2	12.288MHz	-	-	-
24	EAX	IN	EAX	Fix to VCC	-	-	-
25	RESETX	IN	RESETX	System reset	x	LOW	HIGH
26	P66/XT1	OUT	NC	-	-	-	-
27	P67/XT2	OUT	NC	-	-	-	-
28	TEST1	-	TEST1	Test pin (No used)	-	-	-
29	TEST2	-	TEST2	Test pin (No used)	-	-	-
30	VCC	-	+3.3V	Power supply	-	-	-
31	VSS	-	GND	GND	-	-	-
32	ALE	OUT	NC	-	-	-	-
33	P00/AD0	OUT	DRSTX	Display reset	-	LOW	HIGH
34	P01/AD1	OUT	DRS	Resistor select	-	-	LOW
35	P02/AD2	OUT	DRW	Display data read/write	-	-	HIGH
36	P03/AD3	OUT	DE	Display enable	-	-	LOW
37	P04/AD4	OUT	NC	-	-	-	-
38	P05/AD5	OUT	NC	-	-	-	-
39	P06/AD6	OUT	NC	-	-	-	-
40	P07/AD7	OUT	NC	-	-	-	-
41	P10/AD8/A8	I/O	DB0	Display data bus	-	-	-
42	P11/AD9/A9	I/O	DB1	Display data bus	-	-	-
44	P12/AD10/A10	I/O	DB2	Display data bus	-	-	-
46	P13/AD11/A11	I/O	DB3	Display data bus	-	-	-
48	P14/AD12/A12	I/O	DB4	Display data bus	-	-	-
50	P15/AD13/A13	I/O	DB5	Display data bus	-	-	-
52	P16/AD14/A14	I/O	DB6	Display data bus	-	-	-
54	P17/AD15/A15	I/O	DB7	Display data bus	-	-	-
56	P20/A16/A0	OUT	RECLE	Record LED control	x	HIGH	LOW
58	P21/A17/A1	OUT	BKLT	LCD back light control	x	HIGH	LOW
60	P22/A18/A2	OUT	MUTE	Output mute	x	HIGH	HIGH
62	P23/A19/A3	OUT	SPMUTE	Speak mute	x	HIGH	HIGH
64	P24/A20/A4	OUT	POFMUTE	Power off mute	x	HIGH	HIGH
66	P25/A21/A5	OUT	PMWMUT	PMW mute control	x	HIGH	HIGH
68	P26/A22/A6	OUT	XPWCNT	DC/DC control	x	HIGH	LOW
70	P27/A23/A7	OUT	CHGOFF	Charge control	x	HIGH	LOW
72	VCC	-	VCC	Power supply	-	-	-
74	P30/RDX	OUT	KSCAN0	Key scan	-	HIGH	LOW
76	P31/WRX	OUT	KSCAN1	Key scan	-	HIGH	LOW
78	P32/HWRX/SCK	OUT	KSCAN2	Key scan	x	HIGH	LOW
80	P33/SO/SDA	OUT	KSCAN3	Key scan	-	HIGH	LOW
82	P34/SI/SDA	OUT	NC	-	-	-	-
84	P35/INT0	IN	PWRSW	Power SW	0	HIGH	LOW
86	P40/TI0/INT1	OUT	NC	-	-	-	-
88	P41/TO3	OUT	BUZZER	Buzzer output	-	-	LOW
90	P42/TI4/INT4	IN	RC5IN	RC5 input	0	-	HIGH
92	P43/TI5/INT5	OUT	NC	-	-	-	-
94	P44/TO4	OUT	NC	-	-	-	-
96	P45/TI6/INT6	IN	VIN	Power sense	0	LOW	-
98	P46/TI7/INT7	IN	VIN1	Battery sense	0	LOW	-
100	P47/TO6	OUT	NC	-	-	-	-
102	VREFH	IN	+3.3V	AD Ref. high level	-	-	-
104	VREFL	IN	GND	AD Ref. low level	-	-	-
106	AVSS	-	GND	AD GND	-	-	-
108	AVCC	-	+3.3V	AD Power	-	-	-
110	P50/AN0	IN	DCCK	DC power voltage check	-	-	-
112	P51/AN1	IN	GND	-	-	-	-
114	P52/AN2	IN	GND	-	-	-	-
116	P53/AN3/ADTRGX	IN	KSENS0	Key sense	0	HIGH	LOW
118	P54/AN4	IN	KSENS1	Key sense	0	HIGH	LOW

**QU01 : TMP93W40DF**

No.	PIN NAME	I/O	PORT	REMARK	PU	ACTIVE	INIT
1	VREF	-	VERF	Reference voltage	-	-	-
2	AVSS	-	AVSS	Analog GND	-	-	-
3	AVCC	-	AVCC	Analog power supply	-	-	-
4	XNMI	IN	XNMI	No mask interrupt	-	LOW	HIGH
5	P70/TI0	IN	MINT0	DSP monitor line	-	-	-
6	P71/TO1	IN	MINT1	DSP monitor line	-	-	-
7	P72/TO2	IN	MINT2	DSP monitor line	-	-	-
8	P73/TO3	IN	MINT3	DSP monitor line	-	-	-
9	P80/INT4/TI4	IN	XINT	ALDI_FS interrupt	-	LOW	HIGH
10	P81/INT5/TI5	IN	SQSY	SUB-Q/ADIP interrupt	-	LOW	HIGH
11	P82/TO4	OUT	XLAT	Command latch sign	-	-	-
12	P83/TO5	IN	DQSY	SUB-Q/ADIP read line	-	-	-
13	P84/INT6/TI6	OUT	TX	EFM output enable for recording	-	-	-
14	P85/INT7/TI7	OUT	RECP	Laser power change for recording	-	-	-
15	P86/TO6	OUT	CTS	Data send enable/disable	-	-	-
16	P87/INT0	IN	PWRDW	Power down sign	-	LOW	HIGH
17	P90/TXD0	OUT	TXD	Serial data output	-	-	-
18	P91/RXD0	IN	RXD	Serial data input	-	-	-
19	P92/CTS0/SCLK0	IN	RTS	Data receive OK	-	LOW	HIGH
20	P3/TXD1	OUT	SCL	EEP read/write clock	0	-	-
21	P94/RXD1	I/O	SDA	EEP read/write data	0	-	-
22	P95/SCLK1	OUT	XRST	DSP reset sign	-	-	-
23	A8/16	IN	A8/16	Bus setting	-	-	-
24	CLK	OUT	CLK	Clock output	-	-	-
25	VCC	-	VCC	Power supply	-	-	-
26	VSS	-	VSS	Power GND	-	-	-
27	X1	IN	X1	Crystal input	-	-	-
28	X2	OUT	X2	Crystal output	-	-	-
29	XEA	IN	XEA	Internal ROM	-	-	-
30	XRESET	IN	XRESET	u-com reset	-	LOW	HIGH
31	P96/XT1	OUT	NC	Not used	-	-	-
32	P97/XT2	OUT	NC	Not used	-	-	-
33	TEST1	IN	NC	Test pin	-	-	-
34	TEST2	IN	NC	Test pin	-	-	-
35	PA0	IN	TEST0	Not used	-	-	-
36	PA1	IN	TEST1	Not used	-	-	-
37	PA2	IN	TEST2	Not used	-	-	-
38	PA3	IN	TEST3	Not used	-	-	-
39	PA4	IN	TEST4	Not used	-	-	-
40	PA5	IN	TEST5	Not used	-	-	-
41	PA6	IN	TEST6	Not used	-	-	-
42	PA7/SCOUT	IN	TEST7	Not used	-	-	-
43	ALE	OUT	ALE	Not used	-	-	-
44	VCC	-	VCC	Power supply	-	-	-
45	P00/AD0	IN	D0	S-RAM address bus, not used	-	-	-
46	P01/AD1	IN	D1	S-RAM data bus, not used	-	-	-
47	P02/AD2	IN	D2	S-RAM data bus, not used	-	-	-
48	P03/AD3	IN	D3	S-RAM data bus, not used	-	-	-
49	P04/AD4	IN	D4	S-RAM data bus, not used	-	-	-
50	P05/AD5	IN	D5	S-RAM data bus, not used	-	-	-
51	P06/AD6	IN	D6	S-RAM data bus, not used	-	-	-
52	P07/AD7	IN	D7	S-RAM data bus, not used	-	-	-
53	P10/AD8/A8	IN	A8	S-RAM address bus, not used	-	-	-
54	P11/AD9/A9	IN	A9	S-RAM address bus, not used	-	-	-
55	PIN NAME	I/O	PORT	REMARK	PU	ACTIVE	INIT
56	P12/AD10/A10	IN	A10	S-RAM address bus, not used	-	-	-
57	P13/AD11/A11	IN	A11	S-RAM address bus, not used	-	-	-
58	P14/AD12/A12	IN	A12	S-RAM address bus, not used	-	-	-
59	P15/AD13/A13	IN	A13	S-RAM address bus, not used	-	-	-
60	P16/AD14/A14	IN	A14	S-RAM address bus, not used	-	-	-
61	P17/AD15/A15	IN	NC	S-RAM address bus, not used	-	-	-
62	VSS	-	VSS	Power GND	-	-	-
63	VCC	-	VCC	Power supply	-	-	-
64	P20/A0/A16	IN	A0	S-RAM address bus, not used	-	-	-
65	P21/A1/A17	IN	A1	S-RAM address bus, not used	-	-	-
66	P22/A2/A18	IN	A2	S-RAM address bus, not used	-	-	-
67	P23/A3/A19	IN	A3	S-RAM address bus, not used	-	-	-
68	P24/A4/A20	IN	A4	S-RAM address bus, not used	-	-	-
69	P25/A5/A21	IN	A5	S-RAM address bus, not used	-	-	-
70	P26/A6/A22	IN	A6	S-RAM address bus, not used	-	-	-
71	P						

## 14. EXPLODED VIEW AND PARTS LIST

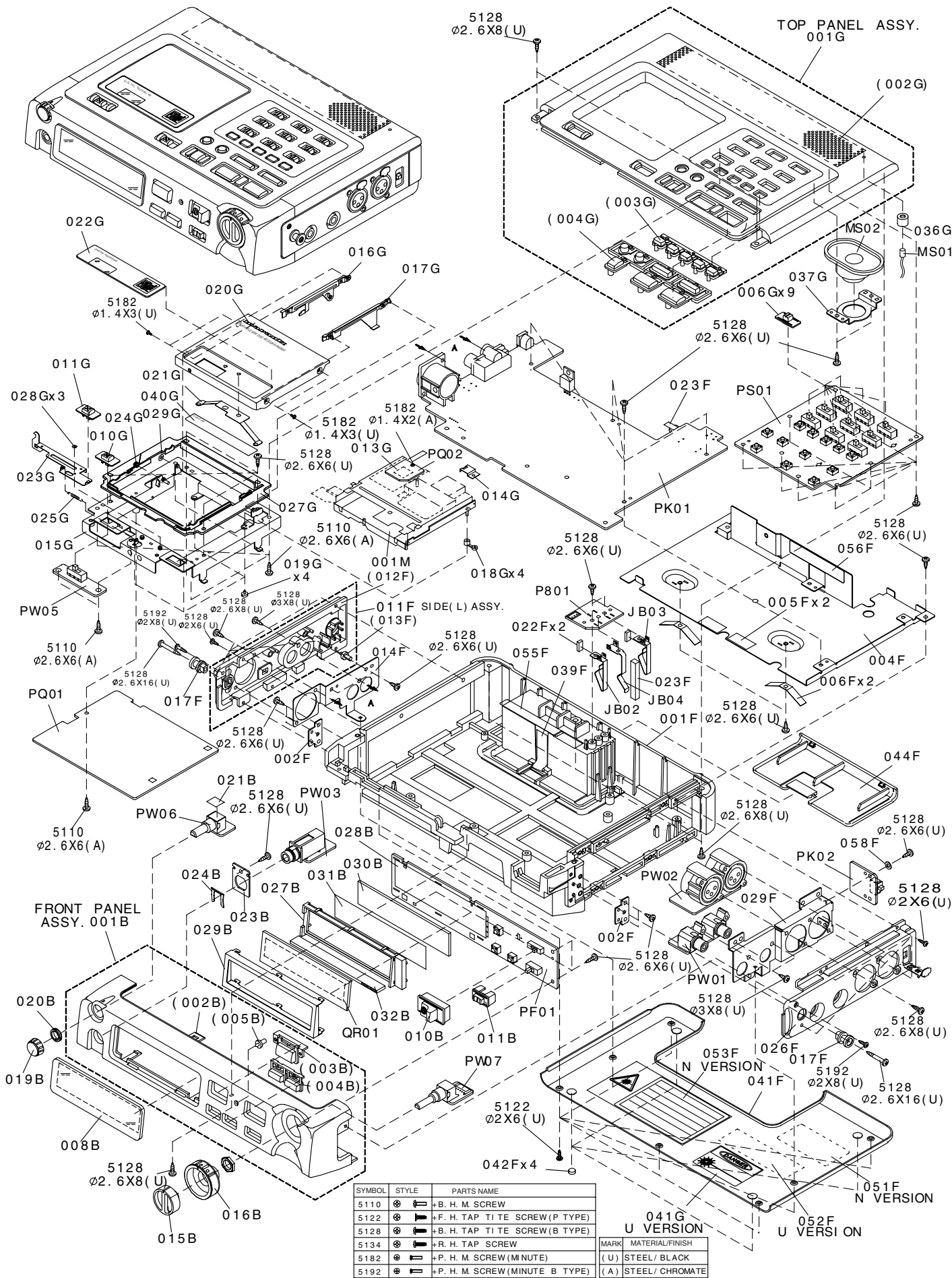

POS. NO	VERS. COLOR	PART NO. (FOR PCS)	DESCRIPTION	PART NO. (MUJ)	POS. NO	VERS. COLOR	PART NO. (FOR PCS)	DESCRIPTION	PART NO. (MUJ)
001B		996500003142	FRONT PANEL K	409S248500	027G			FRAME MECHA FRAME	409S401010
002B			FRONT PANEL	***	028G			WASHER LINK & MECHA	409S012010
003B			BUTTON REC PAUSE	***				CHASSIS	
004B			BUTTON DISPLAY	***	029G			WASHER ARM L & MECHA	409S012020
005B			LENS	***				CHASSIS	
008B		996500003143	WINDOW LCD	409S158020	036G		996500003176	BUFFER MIC BUSH	305H056010
010B		996500003144	KNOB REC	409S154010	037G			BRACKET SPEAKER	409S160030
011B		996500003145	KNOB KEY LOCK	409S154020	040G			LABEL CAUTION	***
015B		996500003146	KNOB REC VOL.KNOB R	409S154030	041G	UBL		LABEL CLASS3B DANGER	***
016B		996500003147	KNOB REC VOL.K L ASSY	409S154540				MD MODULE (adjusted)	ZZ409S3010
019B		996500003148	KNOB PHONE VOL.	378V154040				(Refer to "5. HOW TO DISASSEMBLE")	
020B		996500003149	CIRCULAR NUT	53218069E0	001M		996500003177	MECHANISM	409S304010
021B			MASK FOR VOLUME RT02	409S303010				MD MECHANISM KML-252AAA	
023B			BRACKET HEAD PHONE	409S160040					
024B		996500001559	CLAMPER HEAD PHONE	214K005010					
027B			SPACER LCD	409S118300					
028B			REFRACTOR SEET	409S274010					
029B			HOLDER LCD	409S271300					
030B			LENS LCD	409S355300					
031B			SHEET	409S107300	M01			for MD MECHANISM	
032B			CONTACTOR RUBBER	409S123010				(Refer to "5. HOW TO DISASSEMBLE")	
001F		996500003150	FRAME MAIN	378V401110	SW1			MOTOR FOR EJECT LOCK	*MM001030R
002F		996500003151	BRACKET STRAP	378V160040	SW2			SWITCH FOR PICK-UP	*SP000970R
004F			SHIELD CASE	409S109010	SW3			SWITCH (SHORT)	*SP000950R
005F			INSULATOR FOR SHIELD CASE	409S120010				SWITCH (LONG)	*SP000960R
006F		996500003152	SPRING LEAF	101C115030	MS01		482224230206	MIC UNIT ECM	MS50000150
011F		996500003153	SIDE PANEL LASSY	409S249500	MS02		996500003093	SPEAKER 4ohm 0.5W OVAL	CJ00508140
012F			SIDE PANEL L	***	QR01		996500003097	DISPLAY UNIT LM-1658B	HQ21901860
013F			LENS	***				LCD PANEL FOR PMD650	
014F			BRACKET SIDE L	409S160010	WL01			JUMPER LEAD JL01-JY01	YU25150500
017F		996500003154	SUPPORT STRAP	378V101020	WL02			FFC 25P 1.25mm	YU23100500
022F			BUFFER FOR CONTACTOR	139C056010	WL03		482232162293	JUMPER LEAD JL03-JQ04	YU26100500
023F			BUFFER FOR CONTACTOR	409S056010				FFC 23P 1.0mm	
026F		996500003155	SIDE PANEL R	409S249020	WQ02			FFC 26P 1.0mm	YU16040510
029F			BRACKET SIDE R	409S160020	WQ03			JQ02-MECKA	
039F		996500003156	TAPE BATTERY EJECT	378V157010				JUMPER LEAD FFC 0.5mm 10P	YU10040510
041F	FB		COVER BOTTOM F	378V053230				JQ03-JQ11	
041F	/00B	996500003157	COVER BOTTOM N	378V053210					
041F	UBL		COVER BOTTOM U	378V053220	001T	FB		<b>PACKING</b>	
042F		482246242119	LEG	022D057020	001T	/00B	996500003178	USER GUIDE F	409S851110
044F		996500003161	COVER BATTERY	378V053030	001T	UBL		USER GUIDE N	409S851310
051F	/00B		LABEL CLASS 1 LASER	***	002Z		482249820097	USER GUIDE U	409S851250
052F	UBL		LABEL DANGER	***	005Z		996500003179	STRAP	153T156010
053F	/00B		LABEL CLASS 3B LASER CAUTION	***	▲ 010Z	FB		CASE BATT.CASE ASSY	377V064500
055F			LABEL FUSE CAUTION	***				A.C. ADAPTOR DA600PMD5	AA10013040
056F			LABEL FUSE CAUTION	***	▲ 010Z	UBL		13V 1.0A	
								A.C. ADAPTOR DA600PMDU	AA12013020
								13V 1.0A	
001G		996500003162	CASE TOP K	409S064500					
002G			CASE TOP	***					
003G			BUTTON	***					
004G			BUTTON PLAY	***					
006G		996500003163	KNOB SLIDE FOR PS01	378V154030					
010G		996500003164	KNOB POWER	378V154160					
011G		996500003165	KNOB EJECT	378V154260					
013G			STICKER W-FACE FOR PQ02	409S122010					
014G			COVER FLEXI	409S053020					
015G			CHASSIS MECHA	***					
016G		996500003166	ARM L	409S002010					
017G		996500003167	ARM R	409S002020					
018G		996500003168	DAMPER MECHA	409S130010					
019G		996500003169	SCREW MECHA	409S010020					
020G		996500003170	COVER MD LID	409S053010					
021G		996500003171	LEAF SPRING	409S116010					
022G		996500003172	WINDOW LID	409S158010					
023G		996500003173	LINK	409S121010					
024G		996500003174	SPRING LID	409S115010					
025G		996500003175	SPRING LINK	409S115020					
								<b>NOT STANDARD SPEAR PARTS</b>	
								CUSHION	378V809010
								CUSHION LID	378V809020
								PACKING CASE	409S801010
								MASS CARTON	409S805010

NOTE : \*\*\*=PART IS LISTED FOR REFERENCE ONLY, MARANTZ WILL NOT SUPPLY THESE PARTS.



## 15. ELECTRICAL PARTS LIST

### ASSIGNMENT OF COMMON PARTS CODES.

#### RESISTORS

R\*\*\* : 1) GD05xxx140, Carbon film fixed resistor, ±5% 1/4W  
 R\*\*\* : 2) GD05xxx160, Carbon film fixed resistor, ±5% 1/6W

Resistance value

Examples ;

Resistance value  
 0.1Ω .... 001    10Ω ... 100    1kΩ .... 102    100kΩ .... 104  
 0.5Ω .... 005    18Ω ... 180    2.7kΩ .... 272    680kΩ .... 684  
 1Ω .... 010    100Ω ... 101    10kΩ .... 103    1MΩ .... 105  
 6.8Ω .... 068    390Ω ... 391    22kΩ .... 223    4.7MΩ .... 475

Note : Please distinguish 1/4W from 1/6W by the shape of parts used actually.

#### CAPACITORS

C\*\*\* : CERAMIC CAP.

3) DD1xxx370, Ceramic capacitor  
 Disc type  
 Temp.coeff.P350 ~ N1000, 50V  
 Capacity value  
 Tolerance

Examples ;

Tolerance (Capacity deviation)  
 ±0.25pF .... 0  
 ±0.5pF .... 1  
 ±5% .... 5

\* Tolerance of COMMON PARTS handled here are as follows :

0.5pF ~ 5pF ... ±0.25pF  
 6pF ~ 10pF ... ±0.5pF  
 12pF ~ 560pF ... ±5%

Capacity value

0.5pF ... 005    3pF ... 030    100pF ... 101  
 1pF ... 010    10pF ... 100    220pF ... 221  
 1.5pF ... 015    47pF ... 470    560pF ... 561

C\*\*\* : CERAMIC CAP.

4) DK16xxx300, High dielectric constant ceramic capacitor  
 Disc type  
 Temp.chara. 2B4, 50V  
 Capacity value

Examples ;

Capacity value  
 100pF ... 101    1000pF .... 102    10000pF ... 103  
 470pF ... 471    2200pF .... 222

C\*\*\* : 5) ELECTROLY CAP. (  $\text{⏏}$  ), 6) FILM CAP. (  $\text{⏏}$  )

5) EAxxx10, Electrolytic capacitor  
 One-way lead type, Tolerance ±20%

Working voltage  
 Capacity value

Examples ;

Capacity value  
 0.1μF .... 104    4.7μF ... 475    100μF ... 107  
 0.33μF .... 334    10μF ... 106    330μF ... 337  
 1μF .... 105    22μF ... 226    1100μF ... 118  
 2200μF ... 228

Working voltage

6.3V .... 006    25V ... 025  
 10V .... 010    35V ... 035  
 16V .... 016    50V ... 050

6) DF15xxx350 Plastic film capacitor  
 DF15xxx310 One-way type, Mylar ±5% 50V  
 DF16xxx310 Plastic film capacitor  
 One-way type, Mylar ±10% 50V  
 Capacity value

Examples ;

Capacity value  
 0.001μF (1000pF) ..... 102    0.1μF .... 104  
 0.0018μF ..... 182    0.56μF .... 564  
 0.01μF ..... 103    1μF .... 105  
 0.015μF ..... 153

**NOTE** : 1) The above CODES (R\*\*\*, R\*\*\*, C\*\*\*, C\*\*\* and C\*\*\*) are omitted on the schematic diagram in some case.  
 2) On the occasion, be confirmed the common parts on the parts list.  
 3) Refer to "Common Parts List" for the other common parts (R105, DD4, DK4).

### NOTE ON SAFETY FOR FUSIBLE RESISTOR :

The suppliers and their type numbers of fusible resistors are as follows;

1. KOA Corporation

Part No. (MJI)	Type No. (KOA)	Description
NH05xxx140	RF25SxxxΩJ	(±5% 1/4W)
NH05xxx120	RF50SxxxΩJ	(±5% 1/2W)
NH85xxx110	RF73B2AxxxΩJ	(±5% 1/10W)
NH95xxx140	RF73B2ExxxΩJ	(±5% 1/4W)

\* Resistance value    Resistance value (0.1 - 10kΩ)

2. Matsushita Electronic Components Co., Ltd

Part No. (MJI)	Type No. (MEC)	Description
NF05xxx140	ERD-2FCJxxx	(±5% 1/4W)
RF05xxx140		
NF02xxx140	ERD-2FCGxxx	(±2% 1/4W)
RF02xxx140		

\* Resistance value    \* Resistance value

Examples ;

\* Resistance value  
 0.1Ω .... 001    10Ω ... 100    1kΩ .... 102    100kΩ .... 104  
 0.5Ω .... 005    18Ω ... 180    2.7kΩ .... 272    680kΩ .... 684  
 1Ω .... 010    100Ω ... 101    10kΩ .... 103    1MΩ .... 105  
 6.8Ω .... 068    390Ω ... 391    22kΩ .... 223    4.7MΩ .... 475

### ABBREVIATION AND MARKS

ANT. : ANTENNA	BATT. : BATTERY
CAP. : CAPACITOR	CER. : CERAMIC
CONN. : CONNECTING	DIG. : DIGITAL
HP : HEADPHONE	MIC. : MICROPHONE
μ-PRO : MICROPROCESSOR	REC. : RECORDING
RES. : RESISTOR	SPK : SPEAKER
SW : SWITCH	TRANSF. : TRANSFORMER
TRIM. : TRIMMING	TRS. : TRANSISTOR
VAR. : VARIABLE	X'TAL : CRYSTAL

### NOTE ON SAFETY :

Symbol  $\text{⚠}$  Fire or electrical shock hazard. Only original parts should be used to replaced any part marked with symbol  $\text{⚠}$ . Any other component substitution (other than original type), may increase risk of fire or electrical shock hazard.

### 安全上の注意 :

$\text{⚠}$  がついている部品は、安全上重要な部品です。必ず指定されている部品番号の部品を使用して下さい。

POS. NO	VERS. COLOR	PART NO. (FOR PCS)	DESCRIPTION	PART NO. (MJI)	POS. NO	VERS. COLOR	PART NO. (FOR PCS)	DESCRIPTION	PART NO. (MJI)
FB01			<b>P801-BATTERY CONNECT CIRCUIT BOARD</b>	FS10250940	CE39		482212611687	CER. CHIP 0.1µF +80%-20%	DK98104200
			FUSE 2.5A 60V CCF1N2.5 TE		CE40		482212611687	CER. CHIP 0.1µF +80%-20%	DK98104200
			<b>PF01-FRONT CIRCUIT BOARD</b>		CE41		482212423002	ELECT. CHIP 10µF 16V	EY10601620
			<b>PF01-CAPACITORS</b>	CE44					
CF01		482212611687	CER. CHIP 0.1µF +80%-20%	DK98104200	CE91		482212423002	ELECT. CHIP 10µF 16V	EY10601620
CF02		482212423002	ELECT. CHIP 10µF 16V	EY10601620	CE92		482212423002	ELECT. CHIP 10µF 16V	EY10601620
CF04		482212411432	ELECT. CHIP 100µF 10V	EY10701020	CG01		482212441134	ELECT. 10µF 63V	EA10606310
CF05		996500003158	TANTL CHIP 4.7µF 16V	EY47501670	CG04				
CF06		996500003158	TANTL CHIP 4.7µF 16V	EY47501670	CG05		482212611687	CER. CHIP 0.1µF +80%-20%	DK98104200
CF07		482212611687	CER. CHIP 0.1µF +80%-20%	DK98104200	CG10				
CF08		482212611687	CER. CHIP 0.1µF +80%-20%	DK98104200	CG11		482212423002	ELECT. CHIP 10µF 16V	EY10601620
CF09		482212611687	CER. CHIP 0.1µF +80%-20%	DK98104200	CG12		482212423002	ELECT. CHIP 10µF 16V	EY10601620
			<b>PF01-RESISTORS</b>		CG13		482212611687	CER. CHIP 0.1µF +80%-20%	DK98104200
RF03		482205130479	CHIP 47Ω ±5% 1/16W	NN05470610	CG14		482212611687	CER. CHIP 0.1µF +80%-20%	DK98104200
RF04		482205130479	CHIP 47Ω ±5% 1/16W	NN05470610	CG15		482212611687	CER. CHIP 0.1µF +80%-20%	DK98104200
RF07		482205130153	CHIP 15kΩ ±5% 1/16W	NN05153610	CG16		482212423002	ELECT. CHIP 10µF 16V	EY10601620
RF08		482205130102	CHIP 1kΩ ±5% 1/16W	NN05102610	CG17		482212423002	ELECT. CHIP 10µF 16V	EY10601620
RF09		996500003098	TRIMM. 20kΩ EVM1S TMC3K	NY02030160	CG18		996500003159	ELECT. CHIP 10µF 10V	EY10601040
RF10		482205130102	CHIP 1kΩ ±5% 1/16W	NN05102610	CG19		482212423002	ELECT. CHIP 10µF 16V	EY10601620
			<b>PF01-SEMICONDUCTORS</b>		CG20		996500003160	ELECT. CHIP 22µF 16V	EY22601620
DF02		482213082018	L.E.D. BR1102W	HI10079300	CG21		996500003160	ELECT. CHIP 22µF 16V	EY22601620
DF03		532213010379	L.E.D. LNJ310M6URA GREEN	HI10086020	CG22		482212423002	ELECT. CHIP 10µF 16V	EY10601620
DF04		532213010379	L.E.D. LNJ310M6URA GREEN	HI10086020	CG23		482212423002	ELECT. CHIP 10µF 16V	EY10601620
DF05		532213010379	L.E.D. LNJ310M6URA GREEN	HI10086020	CG24		532212611578	CER. CHIP 0.15µF ±10% 25V B	DK56154210
DF06		532213010379	L.E.D. LNJ310M6URA GREEN	HI10086020	CG25			532212611578	CER. CHIP 0.15µF ±10% 25V B
DF07		532213083285	CHIP DIODE 1SS322	HZ20031050	CG26		532212611578	CER. CHIP 1000pF ±10% B 50V	DK96102300
DF11					CG27		532212611578		532212611578
QF01		996500003095	IC NJU6428CFG1-02 LCD-DRIVER	HC10177090	CG28			CER. CHIP 1µF 16V B	DK46105200
QF02		996500003096	DIG. TRS. DTC123JE RN1105	BA21105000	CG29			CER. CHIP 1µF 16V B	DK46105200
QF03		996500003096	DIG. TRS. DTC123JE RN1105	BA21105000	CG30		482212423002	ELECT. CHIP 10µF 16V	EY10601620
QF04		996500003096	DIG. TRS. DTC123JE RN1105	BA21105000	CG31		482212423002	ELECT. CHIP 10µF 16V	EY10601620
JF01		996500003094	JACK SFW23R-2STE1	YJ07016930	CG32		482212233777	ELECT. CHIP 33µF 10V	EY33601020
SF01		996500003099	SLIDE SWITCH SSSS9-1-2 C	SS01020800	CG35				
SF02		996500001445	PUSH SWITCH TACT SKHMPW	SP01013320	CG36		482212233777	CER. CHIP 47pF ±5% 50V	DD95470300
SF03		996500001445	PUSH SWITCH TACT SKHMPW	SP01013320	CG37		482212233777	CER. CHIP 47pF ±5% 50V	DD95470300
SF04		996500001445	PUSH SWITCH TACT SKHMPW	SP01013320	CG38		482212613883	CER. CHIP 220pF ±5% 50V	DD95221300
SF05		996500003100	SLIDE SWITCH SSST01-3A	SS01021060	CG39		482212613883	CER. CHIP 220pF ±5% 50V	DD95221300
			<b>PK01- MAIN CIRCUIT BOARD</b>		CG40		482212233782	CER. CHIP 56pF GR39	DD95560300
			<b>PK01-CAPACITORS</b>		CG41		482212233782	CER. CHIP 56pF GR39	DD95560300
CE01		482212611687	CER. CHIP 0.1µF +80%-20%	DK98104200	CG42		482212423002	ELECT. CHIP 10µF 16V	EY10601620
CE05					CG43		482212423002		482212423002
CE08		482212423002	ELECT. CHIP 10µF 16V	EY10601620	CG44		482212611671	CER. CHIP 33pF ±5% CG 50V	DD95330300
CE11		482212441842	ELECT. CHIP 47µF 16V	EY47601620	CG45		482212423002	ELECT. CHIP 10µF 16V	EY10601620
CE12		482212441842	ELECT. CHIP 47µF 16V	EY47601620	CG46		482212423002	ELECT. CHIP 10µF 16V	EY10601620
CE13		482212423002	ELECT. CHIP 10µF 16V	EY10601620	CG47		482212233777	CER. CHIP 47pF ±5% 50V	DD95470300
CE16					CG50				
CE18		482212423002	ELECT. CHIP 10µF 16V	EY10601620	CG52		482212411987	TANTL CHIP 10µF 10V	EY10601070
CE20		482212233741	CER. CHIP 10pF ±0.5pF 50V	DD91100300	CG53		482212611687	CER. CHIP 0.1µF +80%-20%	DK98104200
CE21		482212233741	CER. CHIP 10pF ±0.5pF 50V	DD91100300	CG54		482212611687	CER. CHIP 0.1µF +80%-20%	DK98104200
CE23		482212233761	CER. CHIP 22pF ±5% CG 50V	DD95220300	CG61		482212612076	CER. CHIP 0.047µF ±10% 16V	DK56473200
CE24		482212233761	CER. CHIP 22pF ±5% CG 50V	DD95220300	CK01		482212611687	CER. CHIP 0.1µF +80%-20%	DK98104200
CE25		482212233741	CER. CHIP 10pF ±0.5pF 50V	DD91100300	CK09				
CE26		482212233741	CER. CHIP 10pF ±0.5pF 50V	DD91100300	CK10		482212613302	CER. CHIP 8200pF ±10%	DK96822200
CE27		482212423002	ELECT. CHIP 10µF 16V	EY10601620	CK11		482212611687	CER. CHIP 0.1µF +80%-20%	DK98104200
CE28		482212411396	ELECT. CHIP 220µF 4V	EY22700420	CK12		482212423002	ELECT. CHIP 10µF 16V	EY10601620
CE29		482212411432	ELECT. CHIP 100µF 10V	EY10701020	CK23				
CE31		482212423002	ELECT. CHIP 10µF 16V	EY10601620	CK24		482212611671	CER. CHIP 33pF ±5% CG 50V	DD95330300
CE32		482212423002	ELECT. CHIP 10µF 16V	EY10601620	CK25		482212611671	CER. CHIP 33pF ±5% CG 50V	DD95330300
					CK26		996500001438	ELECT. CHIP 2.2µF 50V	EY22505020
					CK27		482212411432	ELECT. CHIP 100µF 10V	EY10701020

POS. NO	VERS. COLOR	PART NO. (FOR PCS)	DESCRIPTION	PART NO. (MJI)	POS. NO	VERS. COLOR	PART NO. (FOR PCS)	DESCRIPTION	PART NO. (MJI)
CK28		482212411432	ELECT. CHIP 100μF 10V	EY10701020	CZ01		482212613837	CER. CHIP 0.1μF ±10% B 10V	DK96104200
CK29		482212411396	ELECT. CHIP 220μF 4V	EY22700420	CZ02		482212611687	CER. CHIP 0.1μF +80%-20%	DK98104200
CK30		482212441842	ELECT. CHIP 47μF 16V	EY47601620	CZ03		482212611687	CER. CHIP 0.1μF +80%-20%	DK98104200
CK31		482212411432	ELECT. CHIP 100μF 10V	EY10701020	CZ04			CER. CHIP 62pF ±5% CH 50V	DD95620300
CK32			ELECT. CHIP 15μF 10V	EY15601020	CZ05		482212411396	ELECT. CHIP 220μF 4V	EY22700420
CK33		482212233777	CER. CHIP 47pF ±5% 50V	DD95470300					
CK34									
CK39		482212611685	CER. CHIP 4700pF ±10% B 50V GR39	DK96472300					
CK40		482212411432	ELECT. CHIP 100μF 10V	EY10701020	RE01		482205130682	CHIP 6.8kΩ ±5% 1/16W	NN05682610
CK41		482212411432	ELECT. CHIP 100μF 10V	EY10701020	RE02		482205130682	CHIP 6.8kΩ ±5% 1/16W	NN05682610
CK42		482212411432	ELECT. CHIP 100μF 10V	EY10701020	RE03		482205130153	CHIP 15kΩ ±5% 1/16W	NN05153610
CK43		482212611687	CER. CHIP 0.1μF +80%-20%	DK98104200	RE04		482211712891	CHIP 220kΩ ±5% 1/16W	NN05224610
CK44		532212611583	CER. CHIP 0.01μF ±10% B 25V	DK96103200	RE05		482205130153	CHIP 15kΩ ±5% 1/16W	NN05153610
CK45		482212233777	CER. CHIP 47pF ±5% CG 50	DD95470300	RE06		482211712891	CHIP 220kΩ ±5% 1/16W	NN05224610
CK46		482212611687	CER. CHIP 0.1μF +80%-20%	DK98104200	RE07		482205130102	CHIP 1kΩ ±5% 1/16W	NN05102610
CK47		482212611687	CER. CHIP 0.1μF +80%-20%	DK98104200	RE08		482205130102	CHIP 1kΩ ±5% 1/16W	NN05102610
CK48					RE09		482211712925	CHIP 47kΩ ±5% 1/16W	NN05473610
CK51		482212611671	CER. CHIP 33pF ±5% CG 50V	DD95330300	RE11		482205130474	CHIP 470kΩ ±5% 1/16W	NN05474610
CK52		482212411396	ELECT. CHIP 220μF 4V	EY22700420	RE12		482211713632	CHIP 100kΩ ±5% 1/16W	NN05104610
CK53			ELECT. CHIP 15μF 10V	EY15601020	RE15		482205130103	CHIP 10kΩ ±5% 1/16W	NN05103610
CK54		482212411229	ELECT. CHIP 4.7μF 35V	EY47503520	RE16		482205130103	CHIP 10kΩ ±5% 1/16W	NN05103610
CK55			ELECT. CHIP 1μF 50V	EY10505020	RE17		482205130101	CHIP 100Ω ±5% 1/16W	NN05101610
CK56		482212611687	CER. CHIP 0.1μF +80%-20%	DK98104200	RE18		482205130101	CHIP 100Ω ±5% 1/16W	NN05101610
CK57		482212613396	CER. CHIP 0.047μF ±10% 16V	DK96473200	RE19		482211712925	CHIP 47kΩ ±5% 1/16W	NN05473610
CK58		482212613302	CER. CHIP 8200pF ±10% GR39	DK96822200	RE20		482211712925	CHIP 47kΩ ±5% 1/16W	NN05473610
CK59		482212613302	CER. CHIP 8200pF ±10% GR39	DK96822200	RE22		482211712925	CHIP 47kΩ ±5% 1/16W	NN05473610
CK60		482212441842	ELECT. CHIP 47μF 16V	EY47601620	RE23		482211712925	CHIP 47kΩ ±5% 1/16W	NN05473610
CK61		482212612495	CER. CHIP 1500pF ±10% B 50V	DK96152300	RE24		482211712891	CHIP 220kΩ ±5% 1/16W	NN05224610
CK63		482212612495	CER. CHIP 1500pF ±10% B 50V	DK96152300	RE25		482211712891	CHIP 220kΩ ±5% 1/16W	NN05224610
CL01					RE26		482205130222	CHIP 2.2kΩ ±1/16W	NN05222610
CL04		482212611687	CER. CHIP 0.1μF +80%-20%	DK98104200	RE27		482205130222	CHIP 2.2kΩ ±5% 1/16W	NN05222610
CL05		482212411125	ELECT. CHIP 1μF 50V	EY10505020	RE28		482205130103	CHIP 10kΩ ±5% 1/16W	NN05103610
CL06		482212611663	CER. CHIP 12pF ±5% CG 50V	DD95120300	RE29		482205130103	CHIP 10kΩ ±5% 1/16W	NN05103610
CL07		482212611663	CER. CHIP 12pF ±5% CG 50V	DD95120300	RE30		482211712902	CHIP 8.2kΩ ±5% 1/16W	NN05822610
CL08			CER. CHIP 2pF ±0.25pF 50V	DD90020300	RE31		482211712902	CHIP 8.2kΩ ±5% 1/16W	NN05822610
CL09			CER. CHIP 2pF ±0.25pF 50V	DD90020300	RE32		482205130153	CHIP 15kΩ ±5% 1/16W	NN05153610
CL10		482212611687	CER. CHIP 0.1μF +80%-20%	DK98104200	RE33		482205130153	CHIP 15kΩ ±5% 1/16W	NN05153610
CL11		482212611687	CER. CHIP 0.1μF +80%-20%	DK98104200	RE37		482205130103	CHIP 10kΩ ±5% 1/16W	NN05103610
CL12		482212411879	BIG ELECT. 1F 5.5V	EX10500530	RE38		482205130103	CHIP 10kΩ ±5% 1/16W	NN05103610
CL13		482212411432	ELECT. CHIP 100μF 10V	EY10701020	RE39		482205130683	CHIP 68kΩ ±5% 1/16W	NN05683610
CL14		482212611687	CER. CHIP 0.1μF +80%-20%	DK98104200	RE40		482205120106	CHIP 10MΩ ±5% 1/16W	NN05106610
CP01					RE45		482205130103	CHIP 10kΩ ±5% 1/16W	NN05103610
CP05		482212611687	CER. CHIP 0.1μF +80%-20%	DK98104200	RE46		482205130103	CHIP 10kΩ ±5% 1/16W	NN05103610
CP06		482212423002	ELECT. CHIP 10μF 16V	EY10601620	RE49		482205130472	CHIP 4.7kΩ ±5% 1/16W	NN05472610
CP07		482212611687	CER. CHIP 0.1μF +80%-20%	DK98104200	RE50		482211712925	CHIP 47kΩ ±5% 1/16W	NN05473610
CP08		482212233761	CER. CHIP 22pF ±5% CG 50V	DD95220300	RE51		482211713632	CHIP 100kΩ ±5% 1/16W	NN05104610
CP09		996500003180	ELECT. 560μF 35V RJH	EF56703510	RE53		482205130103	CHIP 10kΩ ±5% 1/16W	NN05103610
CP10			ELECT. CHIP 47μF 6.3V	EY47600600	RE54		482205130103	CHIP 10kΩ ±5% 1/16W	NN05103610
CP11			ELECT. 120μF 16V RJH	EF12701610	RE55		482205130392	CHIP 3.9kΩ ±5% 1/16W	NN05392610
CP12			ELECT. 39μF 63V RJH	EF39606310	RE56		482205130392	CHIP 3.9kΩ ±5% 1/16W	NN05392610
CP13			ELECT. CHIP 47μF 4V	EY47600420	RE61			CHIP 0Ω ±5% 1/16W	NN05000610
CP14		482212480238	BIG ELECT CAP 0.22F	EX22400520	RE64		482211682487	CHIP 0Ω ±5% 1/16W	NN05000610
CP15		482212480238	BIG ELECT CAP 0.22F	EX22400520	RE91		482205130103	CHIP 10kΩ ±5% 1/16W	NN05103610
CP16		482212441842	ELECT. CHIP 47μF 16V	EY47601620	RE92		482205130103	CHIP 10kΩ ±5% 1/16W	NN05103610
CP17			ELECT. CHIP 15μF 10V	EY15601020	RE93		482205130102	CHIP 1kΩ ±5% 1/16W	NN05102610
CP19			ELECT. CHIP 47μF 4V	EY47600420	RE94		482205130102	CHIP 1kΩ ±5% 1/16W	NN05102610
CP20		482212423002	ELECT. CHIP 10μF 16V	EY10601620	RE95		482211713632	CHIP 100kΩ ±5% 1/16W	NN05104610
CP21		482212613455	CER. CHIP 180pF GR39	DD95181300	RE96		482211713632	CHIP 100kΩ ±5% 1/16W	NN05104610
CP25		482212611687	CER. CHIP 0.1μF +80%-20%	DK98104200	RG01			CHIP 6.8K 1/2W	RI05682120
CP31		482212411125	ELECT. CHIP 1μF 50V	EY10505020	RG04				
CP32		482212411125	ELECT. CHIP 1μF 50V	EY10505020	RG05				
CP92		482212423002	ELECT. CHIP 10μF 16V	EY10601620	RG12		482205130472	CHIP 4.7kΩ ±5% 1/16W	NN05472610
CP93		482212611687	CER. CHIP 0.1μF +80%-20%	DK98104200	RG13				
					RG14		482211712925	CHIP 47kΩ ±5% 1/16W	NN05473610
					RG15		482211713632	CHIP 100kΩ ±5% 1/16W	NN05104610
					RG16		482205130222	CHIP 2.2kΩ ±5% 1/16W	NN05222610
					RG17		482205130103	CHIP 10kΩ ±5% 1/16W	NN05103610

POS. NO	VERS. COLOR	PART NO. (FOR PCS)	DESCRIPTION	PART NO. (MJI)	POS. NO	VERS. COLOR	PART NO. (FOR PCS)	DESCRIPTION	PART NO. (MJI)
RG18		482205130561	CHIP 560Ω ±5% 1/16W	NN05561610	RK05				
RG19		482205130561	CHIP 560Ω ±5% 1/16W	NN05561610	}		482205130103	CHIP 10kΩ ±5% 1/16W	NN05103610
RG20		482205130561	CHIP 560Ω ±5% 1/16W	NN05561610	RK09				
RG21		482211683819	CHIP 18kΩ ±5% 1/16W	NN05183610	RK10		482211713632	CHIP 100kΩ ±5% 1/16W	NN05104610
RG22		482205130103	CHIP 10kΩ ±5% 1/16W	NN05103610	RK12				
RG23		482205130471	CHIP 470Ω ±5% 1/16W	NN05471610	}		482205130103	CHIP 10kΩ ±5% 1/16W	NN05103610
RG25		482211713632	CHIP 100kΩ ±5% 1/16W	NN05104610	RK15				
RG26		482205130683	CHIP 68kΩ ±5% 1/16W	NN05683610	RK16		482205130472	CHIP 4.7kΩ ±5% 1/16W	NN05472610
RG27		482205130683	CHIP 68kΩ ±5% 1/16W	NN05683610	RK17		482205130103	CHIP 10kΩ ±5% 1/16W	NN05103610
RG28		482211712864	CHIP 82kΩ ±5% 1/16W	NN05823610	RK18		482205130222	CHIP 2.2kΩ ±5% 1/16W	NN05222610
RG29		482211712864	CHIP 82kΩ ±5% 1/16W	NN05823610	RK19		482211712925	CHIP 47kΩ ±5% 1/16W	NN05473610
RG30		482205130223	CHIP 22kΩ ±5% 1/16W	NN05223610	RK20		482211712925	CHIP 47kΩ ±5% 1/16W	NN05473610
RG31		482205130223	CHIP 22kΩ ±5% 1/16W	NN05223610	RK21		482211712925	CHIP 47kΩ ±5% 1/16W	NN05473610
RG32		482205130153	CHIP 15kΩ ±5% 1/16W	NN05153610	RK22		482205130223	CHIP 22kΩ ±5% 1/16W	NN05223610
RG33		482205130153	CHIP 15kΩ ±5% 1/16W	NN05153610	RK23		482211713632	CHIP 100kΩ ±5% 1/16W	NN05104610
RG34		482205130332	CHIP 3.3kΩ ±5% 1/16W	NN05332610	RK24		482211712925	CHIP 47kΩ ±5% 1/16W	NN05473610
RG35		482205130333	CHIP 33kΩ ±5% 1/16W	NN05333610	RK25		482211712925	CHIP 47kΩ ±5% 1/16W	NN05473610
RG36		482205130333	CHIP 33kΩ ±5% 1/16W	NN05333610	RK26		482211712925	CHIP 47kΩ ±5% 1/16W	NN05473610
RG37		482205130472	CHIP 4.7kΩ ±5% 1/16W	NN05472610	RK27		482205130103	CHIP 10kΩ ±5% 1/16W	NN05103610
RG38		482205130472	CHIP 4.7kΩ ±5% 1/16W	NN05472610	RK28		482205130103	CHIP 10kΩ ±5% 1/16W	NN05103610
RG39		482205130561	CHIP 560Ω ±5% 1/16W	NN05561610	RK29		482211713632	CHIP 100kΩ ±5% 1/16W	NN05104610
RG40		482205130561	CHIP 560Ω ±5% 1/16W	NN05561610	RK30		482211713632	CHIP 100kΩ ±5% 1/16W	NN05104610
RG41		482205130272	CHIP 2.7kΩ ±5% 1/16W	NN05272610	RK31		482211713632	CHIP 100kΩ ±5% 1/16W	NN05104610
RG42		482205130272	CHIP 2.7kΩ ±5% 1/16W	NN05272610	RK32		482205130479	CHIP 47Ω ±5% 1/16W	NN05470610
RG43		482205130561	CHIP 560Ω ±5% 1/16W	NN05561610	RK33		482205130479	CHIP 47Ω ±5% 1/16W	NN05470610
RG44		482205130561	CHIP 560Ω ±5% 1/16W	NN05561610	RK34		482211713632	CHIP 100kΩ ±5% 1/16W	NN05104610
RG45					RK35		482205130103	CHIP 10kΩ ±5% 1/16W	NN05103610
}		482211712925	CHIP 47kΩ ±5% 1/16W	NN05473610	RK36		482205130103	CHIP 10kΩ ±5% 1/16W	NN05103610
RG49					RK37		482211712925	CHIP 47kΩ ±5% 1/16W	NN05473610
RG50					RK38		482211712925	CHIP 47kΩ ±5% 1/16W	NN05473610
}		482205130272	CHIP 2.7kΩ ±5% 1/16W	NN05272610	RK39		482205130103	CHIP 10kΩ ±5% 1/16W	NN05103610
RG53					RK40		482205130103	CHIP 10kΩ ±5% 1/16W	NN05103610
RG54					RK41				
}		482211713632	CHIP 100kΩ ±5% 1/16W	NN05104610	}		482211713632	CHIP 100kΩ ±5% 1/16W	NN05104610
RG65					RK46				
RG66		482205130223	CHIP 22kΩ ±5% 1/16W	NN05223610	RK47		482205130102	CHIP 1kΩ ±5% 1/16W	NN05102610
RG67		482205130223	CHIP 22kΩ ±5% 1/16W	NN05223610	RK48		482205130102	CHIP 1kΩ ±5% 1/16W	NN05102610
RG68		482205130561	CHIP 560Ω ±5% 1/16W	NN05561610	RK49		482205130223	CHIP 22kΩ ±5% 1/16W	NN05223610
RG69		482205130109	CHIP 10Ω ±5% 1/16W	NN05100610	RK50		482211712925	CHIP 47kΩ ±5% 1/16W	NN05473610
RG70		482211713632	CHIP 100kΩ ±5% 1/16W	NN05104610	RK51		482211712925	CHIP 47kΩ ±5% 1/16W	NN05473610
RG71		482205130101	CHIP 100Ω ±5% 1/16W	NN05101610	RK52		482205130272	CHIP 2.7kΩ ±5% 1/16W	NN05272610
RG72		482205130101	CHIP 100Ω ±5% 1/16W	NN05101610	RK53		482211710158	1Ω ±5% 1/4W	GG05010140
RG73		482211713632	CHIP 100kΩ ±5% 1/16W	NN05104610	RK54		482205210109	10Ω ±5% 1/4W	GG05100140
RG74		482211713632	CHIP 100kΩ ±5% 1/16W	NN05104610	RK55		482205210109	10Ω ±5% 1/4W	GG05100140
RG75		482205130153	CHIP 15kΩ ±5% 1/16W	NN05153610	RK56		482205130223	CHIP 22kΩ ±5% 1/16W	NN05223610
RG76		482205130153	CHIP 15kΩ ±5% 1/16W	NN05153610	RK57		482205130223	CHIP 22kΩ ±5% 1/16W	NN05223610
RG77		482211713632	CHIP 100kΩ ±5% 1/16W	NN05104610	RK58		482205130102	CHIP 1kΩ ±5% 1/16W	NN05102610
RG78		482211713632	CHIP 100kΩ ±5% 1/16W	NN05104610	RK59		482205130102	CHIP 1kΩ ±5% 1/16W	NN05102610
RG79		482211683819	CHIP 18kΩ ±5% 1/16W	NN05183610	RK60				
RG80		482205130105	CHIP 1MΩ ±5% 1/16W	NN05105610	}		482211712891	CHIP 220kΩ ±5% 1/16W	NN05224610
RG81					RK64				
}		482211713632	CHIP 100kΩ ±5% 1/16W	NN05104610	RK65		482205130562	CHIP 5.6kΩ ±5% 1/16W	NN05562610
RG84					RK66		482205130562	CHIP 5.6kΩ ±5% 1/16W	NN05562610
RG85					RK67		482205130151	CHIP 150Ω ±5% 1/16W	NN05151610
}		482211712891	CHIP 220kΩ ±5% 1/16W	NN05224610	RK68		482205130151	CHIP 150Ω ±5% 1/16W	NN05151610
RG90					RK69		482205130223	CHIP 22kΩ ±5% 1/16W	NN05223610
RG91		482205130103	CHIP 10kΩ ±5% 1/16W	NN05103610	RK71		482211713632	CHIP 100kΩ ±5% 1/16W	NN05104610
RG92		482205130103	CHIP 10kΩ ±5% 1/16W	NN05103610	RK72		482205130223	CHIP 22kΩ ±5% 1/16W	NN05223610
RG93		482211713632	CHIP 100kΩ ±5% 1/16W	NN05104610	RK73		482211712925	CHIP 47kΩ ±5% 1/16W	NN05473610
RG94		482211713632	CHIP 100kΩ ±5% 1/16W	NN05104610	RK74		482205130154	CHIP 150kΩ ±5% 1/16W	NN05154610
RG95		482211713632	CHIP 100kΩ ±5% 1/16W	NN05104610	RK75		482205130472	CHIP 4.7kΩ ±5% 1/16W	NN05472610
RG96		482211682487	CHIP 0Ω ±5% 1/16W	NN05000610	RK78		482205130479	CHIP 47Ω ±5% 1/16W	NN05470610
RG97		482211682487	CHIP 0Ω ±5% 1/16W	NN05000610	RK79		482205130479	CHIP 47Ω ±5% 1/16W	NN05470610
RG98		482211713632	CHIP 100kΩ ±5% 1/16W	NN05104610	RK81		482211712891	CHIP 220kΩ ±5% 1/16W	NN05224610
RG99		482211713632	CHIP 100kΩ ±5% 1/16W	NN05104610					
RK01		482205130181	CHIP 180Ω ±5% 1/16W	NN05181610	RL01		482205130103	CHIP 10kΩ ±5% 1/16W	NN05103610
RK02		482205130181	CHIP 180Ω ±5% 1/16W	NN05181610	RL02		482205130103	CHIP 10kΩ ±5% 1/16W	NN05103610
RK03		482211712925	CHIP 47kΩ ±5% 1/16W	NN05473610	RL04		482205130103	CHIP 10kΩ ±5% 1/16W	NN05103610
RK04		482211712925	CHIP 47kΩ ±5% 1/16W	NN05473610	RL05		482211712925	CHIP 47kΩ ±5% 1/16W	NN05473610
					RL06		482205130103	CHIP 10kΩ ±5% 1/16W	NN05103610

POS. NO	VERS. COLOR	PART NO. (FOR PCS)	DESCRIPTION	PART NO. (MJI)	POS. NO	VERS. COLOR	PART NO. (FOR PCS)	DESCRIPTION	PART NO. (MJI)
RL07		482211713632	CHIP 100kΩ ±5% 1/16W	NN05104610	RP49		482205130103	CHIP 10kΩ ±5% 1/16W	NN05103610
RL08		482205130682	CHIP 6.8kΩ ±5% 1/16W	NN05682610	RP50		482211712925	CHIP 47kΩ ±5% 1/16W	NN05473610
RL09					RP51		482211190892	CHIP 0Ω 2X1.25 ±5% 1/10W	NI05000110
RL13		482211713632	CHIP 100kΩ ±5% 1/16W	NN05104610	RP52		482211682487	CHIP 0Ω ±5% 1/16W	NN05000610
RL14		482205130103	CHIP 10kΩ ±5% 1/16W	NN05103610	RP54		482211682487	CHIP 0Ω ±5% 1/16W	NN05000610
RL15		482205130103	CHIP 10kΩ ±5% 1/16W	NN05103610	RP61		482211190896	CHIP 100kΩ ±5% 1/10W	NI05104110
RL16		482205130103	CHIP 10kΩ ±5% 1/16W	NN05103610	RP62		482211190896	CHIP 100kΩ ±5% 1/10W	NI05104110
RL17		482211713632	CHIP 100kΩ ±5% 1/16W	NN05104610	RP63		482211712925	CHIP 47kΩ ±5% 1/16W	NN05473610
RL18		482211713632	CHIP 100kΩ ±5% 1/16W	NN05104610	RP64		482211712925	CHIP 47kΩ ±5% 1/16W	NN05473610
RL19		482205130105	CHIP 1MΩ ±5% 1/16W	NN05105610	RP65		482211190908	CHIP 220kΩ ±5% 1/10W	NI05224110
RL20		482205130103	CHIP 10 kΩ ±5% 1/16W	NN05103610	RP66		482211682487	CHIP 0Ω ±5% 1/16W	NN05000610
RL21		482205130474	CHIP 470kΩ ±5% 1/16W	NN05474610	RP91		482211711449	CHIP 2.2kΩ ±5% 1/10W	NI05222110
RL22		482211712925	CHIP 47 kΩ ±5% 1/16W	NN05473610	RP92		482211711449	CHIP 2.2kΩ ±5% 1/10W	NI05222110
RL23		482211712925	CHIP 47 kΩ ±5% 1/16W	NN05473610	RZ01		482205130103	CHIP 10kΩ ±5% 1/16W	NN05103610
RL24		482205130109	CHIP 10Ω ±5% 1/16W	NN05100610	RZ02		482211713632	CHIP 100kΩ ±5% 1/16W	NN05104610
RL25					RZ03		482211683339	CHIP 56Ω ±5% 1/16W	NN05560610
RL30		482211713632	CHIP 100kΩ ±5% 1/16W	NN05104610	RZ04		482205130759	CHIP 75Ω ±5% 1/16W	NN05750610
RL31		482205130103	CHIP 10kΩ ±5% 1/16W	NN05103610	RZ05		482205130331	CHIP 330Ω ±5% 1/16W	NN05331610
RL41		482205130223	CHIP 22kΩ ±5% 1/16W	NN05223610	RZ06		482211712139	CHIP 22Ω ±5% 1/16W	NN05220610
RP01		482205130472	CHIP 4.7kΩ ±5% 1/16W	NN05472610	RZ07		482211712139	CHIP 22Ω ±5% 1/16W	NN05220610
RP02		482205130101	CHIP 100Ω ±5% 1/16W	NN05101610	RZ08		482211682487	CHIP 0Ω ±5% 1/16W	NN05000610
RP03		482205130472	CHIP 4.7kΩ ±5% 1/16W	NN05472610	RZ09		482211682487	CHIP 0Ω ±5% 1/16W	NN05000610
RP04		482205130681	CHIP 680Ω ±5% 1/16W	NN05681610	RZ10		482205130102	CHIP 1kΩ ±5% 1/16W	NN05102610
RP05		482211710833	CHIP 10kΩ ±5% 1/10W	NI01103110					
RP06		482211711867	CHIP 91kΩ ±1% 1/10W	NI01913110	DE01		482213081324	CHIP DIODE 1SS302	HZ20018050
RP07		482211710476	CHIP 20kΩ ±1% 1/10W	NM12002010	DE02		482213081324	CHIP DIODE 1SS302	HZ20018050
RP08		482205130223	CHIP 22kΩ ±5% 1/16W	NN05223610	DE03		482213080522	CHIP DIODE 1SS300 DAP202U	HZ21006000
RP09		482211711817	CHIP 1.2kΩ ±5% 1/16W	NN05122610	DE05		996500003081	CHIP DIODE DAN235U	HZ20019210
RP10		482211712925	CHIP 47kΩ ±5% 1/16W	NN05473610	DG01		482213081324	CHIP DIODE 1SS302	HZ20018050
RP11		482211712925	CHIP 47kΩ ±5% 1/16W	NN05473610	DG05				
RP12		482211710837	CHIP 100kΩ ±5% 1/10W	NI01104110	}		996500001743	CHIP DIODE 02CZ12-Y	HZ30027050
RP13		482211711867	CHIP 91kΩ ±1% 1/10W	NI01913110	DG08				
RP14		482205130681	CHIP 680Ω ±5% 1/16W	NN05681610	DG09		482213081324	CHIP DIODE 1SS302	HZ20018050
RP15		482205130101	CHIP 100Ω ±5% 1/16W	NN05101610	DG10		996500003082	CHIP DIODE MA704WA	HZ20043020
RP16		482211710476	CHIP 20kΩ ±1% 1/10W	NM12002010	DG11		996500003082	CHIP DIODE MA704WA	HZ20043020
RP17		482205130102	CHIP 1kΩ ±5% 1/16W	NN05102610	DG12		532213083285	CHIP DIODE 1SS322	HZ20031050
RP18		482205130102	CHIP 1kΩ ±5% 1/16W	NN05102610	DG21		996500003081	CHIP DIODE DAN235U	HZ20019210
RP19		482205311478	4.7kΩ ±5% 2W	GA05047020	DK01		482213081324	CHIP DIODE 1SS302	HZ20018050
RP20		482205130102	CHIP 1kΩ ±5% 1/16W	NN05102610	DK02		996500003083	CHIP DIODE MA1S121	HZ20045020
RP21		482211190908	CHIP 220kΩ ±5% 1/10W	NI05224110	DK03		996500003081	CHIP DIODE DAN235U	HZ20019210
RP22		482205130332	CHIP 3.3kΩ ±5% 1/16W	NN05332610	DK04		996500003083	CHIP DIODE MA1S121	HZ20045020
RP23		482205130331	CHIP 330Ω ±5% 1/16W	NN05331610	DL01		482213081324	CHIP DIODE 1SS302	HZ20018050
RP24		482205130332	CHIP 3.3kΩ ±5% 1/16W	NN05332610	DL02		996500001739	CHIP ZENER DIODE 02CZ6.8Z	HZ30015050
RP25		482211713632	CHIP 100kΩ ±5% 1/16W	NN05104610	DL03		996500001739	CHIP ZENER DIODE 02CZ6.8Z	HZ30015050
RP26		482211683829	CHIP 270Ω ±5% 1/16W	NN05271610	DP01		532213083285	CHIP DIODE 1SS322	HZ20031050
RP27		482205130472	CHIP 4.7kΩ ±5% 1/16W	NN05472610	DP02		482213081324	CHIP DIODE 1SS302	HZ20018050
RP28		482211712925	CHIP 47kΩ ±5% 1/16W	NN05473610	DP03		532213010383	CHIP DIODE NSQ03A04	HZ20011100
RP29		482205130563	CHIP 56kΩ ±5% 1/16W	NN05563610	DP04		532213010383	CHIP DIODE NSQ03A04	HZ20011100
RP30			CHIP 330Ω ±5% 1W	RI05331010	DP05				
RP31			4.7kΩ ±5% 2W	GA05047020	}				
RP32			CHIP 150Ω ±5% 1/4W	RI05151140			482213083718	CHIP DIODE EC15QS02L MINI	HZ20006100
RP33		482211711817	CHIP 1.2kΩ ±5% 1/16W	NN05122610	DP07			POWER 1.3A	
RP34		482211711817	CHIP 1.2kΩ ±5% 1/16W	NN05122610	DP08		532213010401	CHIP DIODE EC11FS2	HZ20012100
RP35		482205130103	CHIP 10kΩ ±5% 1/16W	NN05103610	DP09		996500003117	L.E.D. RED LNJ210C6ARA	HI10085020
RP36		482205130103	CHIP 10kΩ ±5% 1/16W	NN05103610	DP10		996500003118	CHIP DIODE 1SS154	HZ20005050
RP37		482205130272	CHIP 2.7kΩ ±5% 1/16W	NN05272610	DP11		532213083285	CHIP DIODE 1SS322	HZ20031050
RP38		482211712925	CHIP 47kΩ ±5% 1/16W	NN05473610	DP12		482213081324	CHIP DIODE 1SS302	HZ20018050
RP39		482211712925	CHIP 47kΩ ±5% 1/16W	NN05473610	DP13		482213081169	CHIP ZENER DIODE 5.6V 02CZ5.6Y	HZ30006050
RP40		482205130562	CHIP 5.6kΩ ±5% 1/16W	NN05562610	DP14		482213081324	CHIP DIODE 1SS302	HZ20018050
RP41		482211683829	CHIP 270Ω ±5% 1/16W	NN05271610	DP15		996500003119	CHIP DIODE MA8033H	HZ30012020
RP42		482205130682	CHIP 6.8kΩ ±5% 1/16W	NN05682610	DP16		482213081324	CHIP DIODE 1SS302	HZ20018050
RP43		482211713632	CHIP 100kΩ ±5% 1/16W	NN05104610	DP17		532213083285	CHIP DIODE 1SS322	HZ20031050
RP44		482205130123	CHIP 12kΩ ±5% 1/16W	NN05123610	DP18		482213083718	CHIP DIODE EC15QS02L	HZ20006100
RP45		482205130223	CHIP 22kΩ ±5% 1/16W	NN05223610	DP45		996500003081	CHIP DIODE DAN235U	HZ20019210
RP46		482205130102	CHIP 1kΩ ±5% 1/16W	NN05102610	DP91		996500001743	CHIP DIODE 02CZ12-Y	HZ30027050
RP47		482205130103	CHIP 10kΩ ±5% 1/16W	NN05103610					
RP48		482211713632	CHIP 100kΩ ±5% 1/16W	NN05104610					

POS. NO	VERS. COLOR	PART NO. (FOR PCS)	DESCRIPTION	PART NO. (MJI)	POS. NO	VERS. COLOR	PART NO. (FOR PCS)	DESCRIPTION	PART NO. (MJI)
QE01		996500002193	IC TC74HC4066AFT	HC706605Y0	QL04		482220917172	MICROPROCESSOR	HU409ST10F
QE02		996500002193	IC TC74HC4066AFT	HC706605Y0				TMP93CS44F μ-COM	
QE03		996500003078	DIG. TRS. DTC115EE	BA20078210	QL05		996500003087	IC S8052ANY-NH-X RESET	HC10089530
QE04		482220990575	IC NJM2068V	HC10168090	QL06		996500003088	IC RS5C372A-E2	HC10036770
QE05		996500003078	DIG. TRS. DTC115EE	BA20078210	QL07		996500001659	DIG. TRS. DTC114TE RN1111	BA21111000
QE06		996500001658	DIG. TRS. RN1113 47K ESM	BA21113050	QL08		996500001659	DIG. TRS. DTC114TE RN1111	BA21111000
QE09		482213062662	DIG. TRS. DTC144EE RN1104	BA21104000	QL09		996500003089	IC S-81233SGUP-DQF-T2	HC98B33530
QE10		482220990575	IC NJM2068V	HC10168090	QL10		482213062662	DIG. TRS. DTC144EE	BA21104000
QE11		482220990575	IC NJM2068V	HC10168090	QL11		482213062662	DIG. TRS. DTC144EE	BA21104000
QE14		996500003084	CHIP TRS. 2SC1586 GR	HX115861B0					
QE15		996500003086	DIG. TRS. DTA114TE RN2111	BA12111000	QP01		996500003084	CHIP TRS. 2SA1586 GR	HX115861B0
QE16		996500001659	DIG. TRS. DTC114TE RN1111	BA21111000	QP02		482213061541	CHIP TRS. 2SC4116GR	HX341161C0
QE91					QP03		482213061541	CHIP TRS. 2SC4116GR	HX341161C0
QE94		482213061541	CHIP TRS. 2SC4116GR	HX341161C0	▲ QP04		996500003126	IC LM2596S-5.0	HC10034360
					▲ QP05		996500003127	IC NJM2360M	HC10153090
					▲ QP06		996500003128	IC LM2586SX-ADJ	HC10032360
QG01		996500003079	IC TC74HC4052AFT	HC705205Y0	QP07		482213061541	CHIP TRS. 2SC4116GR	HX341161C0
QG02		996500003079	IC TC74HC4052AFT	HC705205Y0	QP09		996500003129	IC NJU7201U35	HC98B35090
QG03		482220990575	IC NJM2068V	HC10168090	QP10		482220991016	IC PQ20VZ1U 1A REG.	HC98920320
QG04		996500002193	IC TC74HC4066AFT	HC706605Y0	QP11		482220963385	IC NJM78L05UA REG	HC90005090
QG05		996500002193	IC TC74HC4066AFT	HC706605Y0	QP12		482220990266	IC NJM2904V DUAL OP AMP	HC10173090
QG06		996500003079	IC TC74HC4052AFT	HC705205Y0	QP13		996500003130	TRS. 2SD1802S/T-TL	HT418022B0
QG07		996500001659	DIG. TRS. DTC114TE RN1111	BA21111000	QP14		996500003112	DIG. TRS. UMW1N 2	BA21001000
QG08		482220990575	IC NJM2068V	HC10168090	QP15		996500003096	DIG. TRS. DTC123JE RN1105	BA21105000
QG09		996500001658	DIG. TRS. RN1113	BA21113050	QP16		996500003131	IC AS-211D NI-CD CHARGE IC	HC10391030
QG10		482220990575	IC NJM2068V	HC10168090	QP17		482213061906	DIG. TRS. DTC114EU	BA20035210
QG11		482220990575	IC NJM2068V	HC10168090	QP19		996500003078	DIG. TRS. DTC115EE	BA20078210
QG12		482220990575	IC NJM2068V	HC10168090	QP20		996500003096	DIG. TRS. DTC123JE RN1105	BA21105000
QG13		996500003084	CHIP TRS. 2SA1586 GR	HX115861B0	QP21		482213061541	CHIP TRS. 2SC4116GR	HX341161C0
QG14		482213061541	CHIP TRS. 2SC4116GR	HX341161C0	QP31		996500003132	CHIP TRS. 2SD1006 HK HL	HX410062A0
QG15		996500001659	DIG. TRS. DTC114TS RN1111	BA21111000	QP32		482213063929	CHIP TRS. 2SC3324 B	HX333241B0
QG16		996500001659	DIG. TRS. DTC114TE RN1111	BA21111000	QP91		482213061425	CHIP TRS. 2SC2873 Y	HX328731B0
QG17					QZ01		996500003090	IC SN75176PS	HC10098370
QG20		996500001658	DIG. TRS. RN1113	BA21113050	QZ02		482220917194	IC TC7WU04FU	HC700405U0
QG21		996500001659	DIG. TRS. DTC114TE RN1111	BA21111000				<b>PK01-MISCELLANEOUS</b>	
QG22		996500001659	DIG. TRS. DTC114TE RN1111	BA21111000	FP01		996500003121	PROTECTOR UNIT	FU13206050
QG23		996500003084	CHIP TRS. 2SA1586 GR	HX115861B0				POLY SWITCH RXE135	
QG24		996500003085	DIG. TRS. DTA114YE RN2107	BA12107000	JK02		996500001316	TERMINAL YKC21-3953 GOLD	YT02021500
QG25		482213062662	DIG. TRS. DTC144EE	BA21104000	JL01			JACK FFC CONNEX. S-25 V	YJ07011550
QG26		482213062662	DIG. TRS. DTC144EE	BA21104000	JL02			JACK 23PIN FCC CONNECTOR	YJ07017290
QG27		996500003086	DIG. TRS. DTA114TE	BA12111000				52808-2390	
QG28		482213062662	DIG. TRS. DTC144EE	BA21104000	JL03			JACK 26PIN FCC CONNECTOR	YJ07017320
								52808-2690	
QK01		996500003079	IC TC74HC4052AFT	HC705205Y0	JP02		482226731619	JACK DC JACK 2A	YJ04001060
QK02					JZ02		996500002643	JACK 3P CANNON. NC3MAH	YJ01004070
QK06		482220990575	IC NJM2068V	HC10168090	LK01			EMI FILTER ACF321825-101	FM32101010
QK07		996500003084	CHIP TRS. 2SA1586 GR	HX115861B0	LK02			EMI FILTER ACF321825-101	FM32101010
QK08		482213061541	CHIP TRS. 2SC4116GR	HX341161C0	LP01		996500003124	CHOKE COIL CHIP L 150μH	LC11540170
QK09		532220961872	IC NJM2073M	HC10067090				N06DB151K	
QK10		996500003080	IC NJM2070M	HC10098090	LP02		482215770058	CHOKE COIL CHIP L 100μH	LC11044400
QK11		996500003086	DIG. TRS. DTA114TE RN2111	BA12111000				CD75	
QK12		996500003086	DIG. TRS. DTA114TE RN2111	BA12111000	LP03		996500003125	CHOKE COIL CHIP L 47μH	LC14730160
QK13		996500003086	DIG. TRS. DTA114TE RN2111	BA12111000				N08DPA470K	
QK14		482213061541	CHIP TRS. 2SC4116GR	HX341161C0	LZ01		482215760178	CHIP INDUCTANCE	LU12153010
QK15		482213061425	CHIP TRS. 2SC2873 Y	HX328731B0				NL322522-150K	
QK16		482213063187	DIG. TRS. DTC323TK	BA20048210	LZ02			EMI FILTER ACF321825-101	FM32101010
QK17		482213063187	DIG. TRS. DTC323TK	BA20048210	LZ03			EMI FILTER ACF321825-101	FM32101010
QK18		482213063187	DIG. TRS. DTC323TK	BA20048210	LZ04		482214881381	PULSE TRANSF. TC-1086-26	TP33842010
QK19		996500001659	DIG. TRS. DTC114TE RN1111	BA21111000					
QK20		996500001658	DIG. TRS. RN1113 47K ESM	BA21113050	SL01		482227613185	PUSH SWITCH L-TYPE	SP01011920
QK22		482213062662	DIG. TRS. RN1104 DTC144EEA	BA21104000				NORMALLY OPEN	
QK23		482213061541	CHIP TRS. 2SC4116GR	HX341161C0	SZ01		996500003091	SLIDE SWITCH SSAA12-B	SS01021070
QK24		482213061541	CHIP TRS. 2SC4116GR	HX341161C0	XL01		996500003092	CRYSTAL 12.288MHz SMD-49	JX12001350
QK25		996500003086	DIG. TRS. DTA114TE/RN2111	BA12111000	XL02		482224210255	CRYSTAL 32.768kHz CM200S	JX00002370
QK26		482213063187	DIG. TRS. DTC323TK	BA20048210	XP01		482224211025	CRYSTAL	JX04006350
QK27		482213063187	DIG. TRS. DTC323TK	BA20048210				CERALOCK CSTCC4.00MG	
QK29		996500001659	DIG. TRS. DTC114TE RN1111	BA21111000					
QK30		996500001659	DIG. TRS. DTC114TE RN1111	BA21111000					

POS. NO	VERS. COLOR	PART NO. (FOR PCS)	DESCRIPTION	PART NO. (MJI)	POS. NO	VERS. COLOR	PART NO. (FOR PCS)	DESCRIPTION	PART NO. (MJI)
CT05		532212234098	<b>PK02-PHANTOM</b>		CQ39		532212611583	CER. CHIP 0.01μF ±10% B 25V	DK96103200
ST01		996500003141	<b>CIRCUIT BOARD</b>	DK56103300	CQ42		482212611685	CER. CHIP 4700pF ±10% B 50V	DK96472300
			CER. CHIP 0.01μF ±10%	SS02021710	CQ50		482212411432	ELECT. CHIP 100μF 10V	EY10701020
			SLIDE SWITCH PHANTOM		CQ51		482212611687	CER. CHIP 0.1μF +80%-20%	DK98104200
			SSAA22-B		CQ54		482212611687	CER. CHIP 0.1μF +80%-20%	DK98104200
					CQ55		482212231765	CER. CHIP 100pF ±5% 50V	DD95101300
					CQ56		482212231765	CER. CHIP 100pF ±5% 50V	DD95101300
CD01			<b>PQ01-MD CIRCUIT BOARD</b>		CQ57		482212231765	CER. CHIP 100pF ±5% 50V	DD95101300
CD02	482212611687		<b>PQ01-CAPACITORS</b>		CQ58		532212611583	CER. CHIP 0.01μF ±10% B 25V	DK96103200
CD03	482212411987		ELECT. CHIP 33μF 10V	EY33601020	CQ59		482212611687	CER. CHIP 0.1μF +80%-20%	DK98104200
CD11	482212423002		CER. CHIP 0.1μF +80%-20%	DK98104200	CQ60		482212411432	ELECT. CHIP 100μF 10V	EY10701020
CD12	482212423002		TANTL CHIP 10μF 10V	EY10601070	CQ61		482212611687	CER. CHIP 0.1μF +80%-20%	DK98104200
CD13	482212612339		ELECT. CHIP 10μF 16V	EY10601620	CQ62		482212611687	CER. CHIP 0.1μF +80%-20%	DK98104200
CD14	482212612339		ELECT. CHIP 10μF 16V	EY10601620	CQ63		532212611583	CER. CHIP 0.01μF ±10% B 25V	DK96103200
CD15	996500003158		CER. CHIP 2200pF GR39	DK96222300	CQ64			CER. CHIP 0.47μF ±5% B 16V	DK56474200
CD16	996500003158		CER. CHIP 2200pF GR39	DK96222300	CQ65		482212613883	CER. CHIP 220pF ±5% CG 50V	DD95221300
CD17	482212611687		TANTL CHIP 4.7μF 16V	EY47501670	CQ66			CER. CHIP 0.47μF ±5% B 16V	DK56474200
CD18	482212611687		TANTL CHIP 4.7μF 16V	EY47501670	CQ67	482212614581		CER. CHIP 0.015μF ±10% X7R	DK96153200
CD19	482212611687		CER. CHIP 0.1μF +80%-20%	DK98104200	CQ70	482212611687		CER. CHIP 0.1μF +80%-20%	DK98104200
CD20	482212411987		CER. CHIP 0.1μF +80%-20%	DK98104200	CQ71	482212411432		ELECT. CHIP 100μF 10V	EY10701020
CD21	482212611687		TANTL CHIP 10μF 10V	EY10601070	CQ72	482212611687		CER. CHIP 0.1μF +80%-20%	DK98104200
CD22	482212411987		CER. CHIP 0.1μF +80%-20%	DK98104200	CQ73	482212611687		CER. CHIP 0.1μF +80%-20%	DK98104200
CD23	482212611687		TANTL CHIP 10μF 10V	EY10601070	CQ74			ELECT. CHIP 22μF 8V	EY22600800
CD24	482212611687		CER. CHIP 0.1μF +80%-20%	DK98104200	CQ76			CER. CHIP 1000pF ±20% 500V	DK47102500
CD25	482212611687		CER. CHIP 0.1μF +80%-20%	DK98104200	CQ77	482212611659		CER. CHIP 3pF ±0.25pF CJ50V	DD90030300
CD26	996500003158		TANTL CHIP 4.7μF 16V	EY47501670	CQ78	482212611659		CER. CHIP 3pF ±0.25pF CJ50V	DD90030300
CD27	482212611687		CER. CHIP 0.1μF +80%-20%	DK98104200	CQ79	482212611687		CER. CHIP 0.1μF +80%-20%	DK98104200
CD30	482212611687		CER. CHIP 0.1μF +80%-20%	DK98104200	CQ80	482212411432		ELECT. CHIP 100μF 10V	EY10701020
CD31	482212423002		ELECT. CHIP 10μF 16V	EY10601620	CQ81	482212611687		CER. CHIP 0.1μF +80%-20%	DK98104200
CD32	482212423002		ELECT. CHIP 10μF 16V	EY10601620	CQ82	482212411131		ELECT. CHIP 47μF 6.3V	EY47600620
CD33	482212611568		CER. CHIP 470pF GR39	DK96471300	CQ84	482212611687		CER. CHIP 0.1μF +80%-20%	DK98104200
CD34	482212611568		CER. CHIP 470pF GR39	DK96471300	CQ85	482212613837		CER. CHIP 0.1μF ±10% B 10V	DK96104200
CD35	482212614256		CER. CHIP 1200pF	DK96122300	CQ90	482212611687		CER. CHIP 0.1μF +80%-20%	DK98104200
CD36	482212614256		CER. CHIP 1200pF	DK96122300	CQ91	482212411432		ELECT. CHIP 100μF 10V	EY10701020
CD51	482212613837		CER. CHIP 0.1μF ±10% B 10V	DK96104200	CQ92	482212611687		CER. CHIP 0.1μF +80%-20%	DK98104200
					CQ93	532212611583		CER. CHIP 0.01μF ±10% B 25V	DK96103200
CQ01	482212411432		ELECT. CHIP 100μF 10V	EY10701020	CQ94	532212611583		CER. CHIP 0.01μF ±10% B 25V	DK96103200
CQ02	482212411432		ELECT. CHIP 100μF 10V	EY10701020	CQ95	482212611687		CER. CHIP 0.1μF +80%-20%	DK98104200
CQ03	482212611687		CER. CHIP 0.1μF +80%-20%	DK98104200	CQ96	482212232672		TANTL CHIP 1μF 16V	EY10501610
CQ04	482212611687		CER. CHIP 0.1μF +80%-20%	DK98104200	CU01	482212411436		ELECT. CHIP 220μF 6.3V	EY22700690
CQ05	482212411396		ELECT. CHIP 220μF 4V	EY22700420	CU02	482212611687		CER. CHIP 0.1μF +80%-20%	DK98104200
CQ06	482212611687		CER. CHIP 0.1μF +80%-20%	DK98104200	CU03	482212611659		CER. CHIP 39F ±0.2pF CJ 50V	DD90030300
CQ07	482212411432		ELECT. CHIP 100μF 10V	EY10701020	CU03	482212611659		CER. CHIP 39F ±0.2pF CJ 50V	DD90030300
CQ08	482212411432		ELECT. CHIP 100μF 10V	EY10701020	CU05	482212231765		CER. CHIP 100pF ±5% 50V	DD95101300
CQ09	996500003159		ELECT. CHIP 10μF 10V	EY10601040	CU06	482212231765		CER. CHIP 100pF ±5% 50V	DD95101300
CQ10	482212411987		TANTL CHIP 10μF 10V	EY10601070	CU07	532212611578		CER. CHIP 1000pF ±10% B 50V	DK96102300
CQ11	482212611687		CER. CHIP 0.1μF +80%-20%	DK98104200	CU08	482212611687		CER. CHIP 0.1μF +80%-20%	DK98104200
CQ12	482212611687		CER. CHIP 0.1μF +80%-20%	DK98104200	CU09	482212611687		CER. CHIP 0.1μF +80%-20%	DK98104200
CQ13	482212611687		CER. CHIP 0.1μF +80%-20%	DK98104200	CU10	482212231765		CER. CHIP 100pF ±5% 50V	DD95101300
CQ14	532212611583		CER. CHIP 0.01μF ±10% B 25V	DK96103200	CU11	482212231765		CER. CHIP 100pF ±5% 50V	DD95101300
CQ15	532212232654		CER. CHIP 0.022μF ±10% XTR	DK96223200	CU20	482212611687		CER. CHIP 0.1μF +80%-20%	DK98104200
CQ16	482212411987		TANTL CHIP 10μF 10V	EY10601070	CU21	482212411432		ELECT. CHIP 100μF 10V	EY10701020
CQ17	482212611687		CER. CHIP 0.1μF +80%-20%	DK98104200	CU22	482212613837		CER. CHIP 0.1μF ±10% B 10V	DK96104200
CQ18	482212611687		CER. CHIP 0.1μF +80%-20%	DK98104200	CU36	482212613837		CER. CHIP 0.1μF ±10% B 10V	DK96104200
CQ19	482212411432		ELECT. CHIP 100μF 10V	EY10701020	CU37	482212613837		CER. CHIP 0.1μF ±10% B 10V	DK96104200
CQ21	482212411987		TANTL CHIP 10μF 10V	EY10601070					
CQ22			CER. CHIP 1000pF ±5% CH	DD95102200					
CQ23	482212612105		CER. CHIP 0.033μF ±10%	DK96333200					
CQ24	532212611582		CER. CHIP 6800pF ±10% GR39	DK96682300	RD01	482205130103		CHIP 10kΩ ±5% 1/16W	NN05103610
CQ28	996500003102		CER. CHIP 0.068μF ±10%	DK96683200	RD02	482205130103		CHIP 10kΩ ±5% 1/16W	NN05103610
CQ29	482212611685		CER. CHIP 4700pF ±10% B 50V	DK96472300	RD03	482211712968		CHIP 820Ω ±5% 1/16W	NN05821610
CQ30			CER. CHIP 1μF ±10% 16V B	DK46105200	RD04	482205130102		CHIP 1kΩ ±5% 1/16W	NN05102610
CQ31	996500000599		CER. CHIP 0.22μF ±10% B 10V	DK96224200	RD05	482205130102		CHIP 1kΩ ±5% 1/16W	NN05102610
CQ32	482212613837		CER. CHIP 0.1μF ±10% B 10V	DK96104200	RD11	482205130471		CHIP 470Ω ±5% 1/16W	NN05471610
CQ33	532212611583		CER. CHIP 0.01μF ±10% B 25V	DK96103200	RD12	482205130471		CHIP 470Ω ±5% 1/16W	NN05471610
CQ34	482212613837		CER. CHIP 0.1μF ±10% B 10V	DK96104200	RD13	482205130223		CHIP 22kΩ ±5% 1/16W	NN05223610
CQ35	482212411987		TANTL CHIP 10μF 10V	EY10601070	RD14	482205130223		CHIP 22kΩ ±5% 1/16W	NN05223610
CQ36	482212411987		TANTL CHIP 10μF 10V	EY10601070					
CQ37	482212611687		CER. CHIP 0.1μF +80%-20%	DK98104200					
CQ38	532212611583		CER. CHIP 0.01μF ±10% B 25V	DK96103200					

POS. NO	VERS. COLOR	PART NO. (FOR PCS)	DESCRIPTION	PART NO. (MJI)	POS. NO	VERS. COLOR	PART NO. (FOR PCS)	DESCRIPTION	PART NO. (MJI)
RD22		482205130101	CHIP 100Ω ±5% 1/16W	NN05101610	RQ67		482211682487	CHIP 0Ω ±5% 1/16W	NN05000610
RD26					RQ68		482211713632	CHIP 100kΩ ±5% 1/16W	NN05104610
RD31		482211713632	CHIP 100kΩ ±5% 1/16W	NN05104610	RQ70		482205130103	CHIP 10kΩ ±5% 1/16W	NN05103610
RD32		482211713632	CHIP 100kΩ ±5% 1/16W	NN05104610	RQ71		482211712925	CHIP 47kΩ ±5% 1/16W	NN05473610
RD33		482205130682	CHIP 6.8kΩ ±5% 1/16W	NN05682610	RQ72		482211712925	CHIP 47kΩ ±5% 1/16W	NN05473610
RD36					RQ73		482205110108	1Ω ±5% 1/4W	NX05010140
RD37		482205130221	CHIP 220Ω ±5% 1/16W	NN05221610	RQ74		482205110108	1Ω ±5% 1/4W	NX05010140
RD38		482205130221	CHIP 220Ω ±5% 1/16W	NN05221610	RQ77		482205130105	CHIP 1MΩ ±5% 1/16W	NN05105610
RD51		482205130223	CHIP 22kΩ ±5% 1/16W	NN05223610	RQ80		482205130222	CHIP 2.2kΩ ±5% 1/16W	NN05222610
RD52		482205130223	CHIP 22kΩ ±5% 1/16W	NN05223610	RQ81		482205130332	CHIP 3.3kΩ ±5% 1/16W	NN05332610
RD53		482211713632	CHIP 100kΩ ±5% 1/16W	NN05104610	RQ82		482205130153	CHIP 15kΩ ±5% 1/16W	NN05153610
RD54		482211713632	CHIP 100kΩ ±5% 1/16W	NN05104610	RQ91		482211190892	CHIP 0Ω 2X1.25 ±5% 1/10W	NI05000110
RD55		482211713632	CHIP 100kΩ ±5% 1/16W	NN05104610	RU01		482205130103	CHIP 10kΩ ±5% 1/16W	NN05103610
RQ01			CHIP 560Ω ±5% 1/10W	NI01561110	RU13				
RQ02		482211710833	CHIP 10kΩ ±5% 1/10W	NI01103110	RU14		482211713632	CHIP 100kΩ ±5% 1/16W	NN05104610
RQ10		482205130153	CHIP 15kΩ ±5% 1/16W	NN05153610	RU15		482211713632	CHIP 100kΩ ±5% 1/16W	NN05104610
RQ11		482211712925	CHIP 47kΩ ±5% 1/16W	NN05473610	RU20		482205130103	CHIP 10kΩ ±5% 1/16W	NN05103610
RQ12		482205130102	CHIP 1kΩ ±5% 1/16W	NN05102610	RU21		482205130103	CHIP 10kΩ ±5% 1/16W	NN05103610
RQ13		482205130102	CHIP 1kΩ ±5% 1/16W	NN05102610	RU23		482211682487	CHIP 0Ω ±5% 1/16W	NN05000610
RQ14		482205130102	CHIP 1kΩ ±5% 1/16W	NN05102610	RU36		482211713632	CHIP 100kΩ ±5% 1/16W	NN05104610
RQ15		482205130472	CHIP 4.7kΩ ±5% 1/16W	NN05472610	RU37		482211713632	CHIP 100kΩ ±5% 1/16W	NN05104610
RQ16		482205130335	CHIP 3.3MΩ ±5% 1/16W	NN05335610					
RQ17		482205130474	CHIP 470kΩ ±5% 1/16W	NN05474610	DD11		482213081324	CHIP DIODE 1SS302	HZ20018050
RQ18		482205130474	CHIP 470kΩ ±5% 1/16W	NN05474610	DD12		482213081324	CHIP DIODE 1SS302	HZ20018050
RQ19		482205130681	CHIP 680Ω ±5% 1/16W	NN05681610	DQ10		482213083629	CHIP DIODE DA114	HZ20010210
RQ20		482205110108	1Ω ±5% 1/4W	NX05010140	DQ60		996500003103	CHIP DIODE F1J6 60V 1A	HZ20006070
RQ21			CHIP 2.2Ω ±5% 1/2W	RI05022120	DQ61		996500003103	CHIP DIODE F1J6 60V 1A	HZ20006070
RQ22		482211713632	CHIP 100kΩ ±5% 1/16W	NN05104610	DQ91		482213081324	CHIP DIODE 1SS302	HZ20018050
RQ23		482205130472	CHIP 4.7kΩ ±5% 1/16W	NN05472610					
RQ24		482205130103	CHIP 10kΩ ±5% 1/16W	NN05103610	QD20		482220917168	IC AK4512 16BIT ADC DAC	HC10021480
RQ25		482205130103	CHIP 10kΩ ±5% 1/16W	NN05103610	QD21		482220930602	IC LM317LM 1.2-37V 0.1A	HC98137360
RQ26		482211713632	CHIP 100kΩ ±5% 1/16W	NN05104610	QD30		482220990575	IC NJM2068V	HC10168090
RQ27		482211713632	CHIP 100kΩ ±5% 1/16W	NN05104610	QD53		482213062662	DIG. TRS. DTC144EE	BA21104000
RQ28		482205130332	CHIP 3.3kΩ ±5% 1/16W	NN05332610	QD54		482213062662	DIG. TRS. DTC144EE	BA21104000
RQ29		482205130103	CHIP 10kΩ ±5% 1/16W	NN05103610	QD55		482213062662	DIG. TRS. DTC144EE	BA21104000
RQ30		482205130332	CHIP 3.3kΩ ±5% 1/16W	NN05332610	QD56		482220917194	IC TC7WU04FU	HC700405U0
RQ31		482205130103	CHIP 10kΩ ±5% 1/16W	NN05103610					
RQ32		482211712925	CHIP 47kΩ ±5% 1/16W	NN05473610	QQ01		482220917171	IC L88MS33T	HC98503030
RQ33		482205130103	CHIP 10kΩ ±5% 1/16W	NN05103610	QQ02		996500003111	IC S81227SGUP-DQZ-T1	HC98B27530
RQ34		482205130103	CHIP 10kΩ ±5% 1/16W	NN05103610	QQ10		482220917546	IC CXA2523AR	HC10060250
RQ35		482205130103	CHIP 10kΩ ±5% 1/16W	NN05103610	QQ11		482213060862	CHIP TRS. 2SA1576 FQ FR	HX115762A0
RQ36		482205130222	CHIP 2.2kΩ ±5% 1/16W	NN05222610	QQ12		996500003112	DIG. TRS. UMW1N 2TRS.	BA21001000
RQ37		482205130222	CHIP 2.2kΩ ±5% 1/16W	NN05222610	QQ13		996500003096	DIG. TRS. DTC123JE RN1105	BA21105000
RQ38		482205130222	CHIP 2.2kΩ ±5% 1/16W	NN05222610	QQ14		996500003096	DIG. TRS. DTC123JE RN1105	BA21105000
RQ39		482205130101	CHIP 100Ω ±5% 1/16W	NN05101610	QQ15		482213062599	DIG. TRS. DTA144EE RN2104	BA12104000
RQ40		482211682487	CHIP 0Ω ±5% 1/16W	NN05000610	QQ16		482213062599	DIG. TRS. DTA144EE RN2104	BA12104000
RQ41		482205130681	CHIP 680Ω ±5% 1/16W	NN05681610	QQ17		482213042734	CHIP TRS. 2SB798 DL DK	HX207982A0
RQ42		482211682487	CHIP 0Ω ±5% 1/16W	NN05000610	QQ50		482220917547	IC CXD2652AR	HC10061250
RQ43		482205130331	CHIP 330Ω ±5% 1/16W	NN05331610	QQ51		996500003113	IC GM71V16400CT-60 16M	HC10086000
RQ44		482211682487	CHIP 0Ω ±5% 1/16W	NN05000610	QQ52		482220917547	IC TC7S08F	HC700805S0
RQ45		482211682487	CHIP 0Ω ±5% 1/16W	NN05000610	QQ70		482220917552	IC 74ACT540FT	HC006405K0
RQ46		482205130101	CHIP 100Ω ±5% 1/16W	NN05101610	QQ71		996500003096	DIG. TRS. DTC123JE RN1105	BA21105000
RQ47		482211683211	CHIP 1.8kΩ ±5% 1/16W	NN05182610	QQ72		482213063611	CHIP FET 2SJ238	HY10238000
RQ50		482205130103	CHIP 10kΩ ±5% 1/16W	NN05103610	QQ73		482213063468	CHIP FET 2SK1764	HY21764000
RQ51		482205130103	CHIP 10kΩ ±5% 1/16W	NN05103610	QQ77		482220917194	IC TC7WU04FU	HC700405U0
RQ52		482205130103	CHIP 10kΩ ±5% 1/16W	NN05103610	QQ80		482213061627	CHIP TRS. 2SA1577 Q	HX115771A0
RQ53		482211682487	CHIP 0Ω ±5% 1/16W	NN05000610	QQ81		996500003114	CHIP TRS. 2SC4081 BS	HX340811C0
RQ54		482205130221	CHIP 220Ω ±5% 1/16W	NN05221610	QQ84		482220917554	IC LB1638M MOTOR DRIVER	HC10378030
RQ55		482205130103	CHIP 10kΩ ±5% 1/16W	NN05103610	QQ85		482213061425	CHIP TRS. 2SC2873	HX328731B0
RQ56		482211713632	CHIP 100kΩ ±5% 1/16W	NN05104610	QQ90		996500003115	IC BH6512FS	HC10196210
RQ57		482205130105	CHIP 1MΩ ±5% 1/16W	NN05105610					
RQ60		482205130332	CHIP 3.3kΩ ±5% 1/16W	NN05332610	QU01		996500001345	MICROPROCESSOR TMP93CW40DF μ-COM	HU409ST00F
RQ62		482205130102	CHIP 1kΩ ±5% 1/16W	NN05102610					
RQ64		482205130102	CHIP 1kΩ ±5% 1/16W	NN05102610	QU02		996500003096	DIG. TRS. DTC123JE RN1105	BA21105000
RQ65		482205130151	CHIP 150Ω ±5% 1/16W	NN05151610	QU20		996500003101	IC AT24C02N-10SI-2.7 2KBIT	HC10028990
RQ66		482211682487	CHIP 0Ω ±5% 1/16W	NN05000610					



POS. NO	VERS. COLOR	PART NO. (FOR PCS)	DESCRIPTION	PART NO. (MJI)	POS. NO	VERS. COLOR	PART NO. (FOR PCS)	DESCRIPTION	PART NO. (MJI)
JQ01		996500003104	<b>PQ01-MISCELLANEOUS</b> JACK HED07	YJ07006770	SY20		996500003136	SLIDE SWITCH SSSF022-S06N0	SS02021680
JQ02		996500003105	JACK 0.5mm 22P SFV22R-2STE1	YJ07012590	SY21		482227721764	SLIDE SWITCH SSSF 2-3	SS02030680
JQ03		996500003106	JACK 0.5mm 16P SFV16R-1STE1	YJ07010770	CT01 }	CT04	482212240617	<b>PW01-SPDIF &amp; RC-5 RCA CIRCUIT BOARD</b> CER. 0.1µF +80%-20% 50V DC	DD38104010
JQ04		996500003107	JACK 1.0mm 26P SFV26R-2STE1	YJ07016960					
JQ05		482226531065	JACK 1.25mm 53261-0310 SMD	YJ07006730	JT03		482229081638	TERMINAL 14X14 RA 1L1P BLK	YT02010790
JQ20			JACK 1.25mm 53261-0510 SMD	YJ07006750	JT04		996500003137	TERMINAL RCA 1L1P ORG	YT02010830
LQ10	}	996500003109	FERRITE CORE FB M J2125HM330-T	FC90020100	CT11	CT12	482212240617	CER. 0.1µF +80%-20% 50V DC	DD38104010
LQ16		996500003109	FERRITE CORE FB M	FC90020100			482212240617	CER. 0.1µF +80%-20% 50V DC	DD38104010
LQ50		996500003109	FERRITE CORE FB M	FC90020100	JT01	JT02	996500002540	JACK NC3FAH2 4P CANON	YJ01004340
LQ60		996500003110	CHOKO COIL 22µH #7A06V POWER INDUCTOR	LC22230050			996500002540	JACK NC3FAH2 4P CANON.	YJ01004340
LQ92					JT05		996500003138	<b>PW03-PHONE JACK CIRCUIT BOARD</b> JACK HLJ5305-01-4170	YJ01004540
SQ01		482227613868	PUSH SWITCH DETECT ESE11SV1	SP01012420					
XQ71		996500003116	CRYSTAL 22.5792MHz SMD-49	JX22001350	ST02		996500003100	<b>PW05-POWER CIRCUIT BOARD</b> SLIDE SWITCH SSST01-3A	SS01021060
XU01		996500001597	CRYSTAL CM309S 20MHz	JX20001360					
JQ10		996500003108	<b>PQ02-REC CIRCUIT BOARD</b> JACK 0.5mm 6P SFV6R-2STE1	YJ07012580	RT02		996500003140	<b>PW06-PLAY VR CIRCUIT BOARD</b> VARIABLE PLAY LEVEL VR	RM01031130
JQ11		996500003106	JACK 0.5mm 10P SFV10R-2STE1	YJ07011740					
CY01		482212230043	<b>PS01-TOP CIRCUIT BOARD</b> <b>PS01-CAPACITORS</b> CER. 0.01µF +80%-20% 50V	DK18103310	RT01		996500003139	<b>PW07-REC VR CIRCUIT BOARD</b> VARIABLE REC LEVEL VR	RM01031140
RY01	}		<b>PS01-RESISTORS</b>  10kΩ ±5% 1/6W	GD05103160					
RY05									
DY04	}	482213032362	<b>PS01-SEMICONDUCTORS</b> DIODE 1SS176 MA165 1SS254 30V 0.1A	HD20002000					
DY06									
DY11	}	482213032362	DIODE 1SS176 MA165 1SS254 30V 0.1A	HD20002000					
DY22									
JY01			<b>PS01-MISCELLANEOUS</b> JACK FFC CONNECTOR 25P 9604S-19F	YJ07011180					
SY01	}	996500000373	PUSH SWITCH EVQ11L05R H H 5mm 160GF	SP01013370					
SY12			996500003133	SLIDE SWITCH SSSF012-S06N0	SS01021090				
SY13		996500003133	SLIDE SWITCH SSSF012-S06N0	SS01021090					
SY14		996500003133	SLIDE SWITCH SSSF013-S06N0	SS01030350					
SY15		996500003134	SLIDE SWITCH SSSF013-S06N0	SS01030350					
SY16		996500003134	SLIDE SWITCH SSSF013-S06N0	SS01030350					
SY17		996500003135	SLIDE SWITCH SSSF013 ALC/LIMITTER/MANUAL	SS01030370					
SY18		996500003134	SLIDE SWITCH SSSF013-S06N0	SS01030350					
SY19		996500003136	SLIDE SWITCH SSSF022-S06N0	SS02021680					