

Service Manual

PMD680 /U1B, /W1B

PMD690 /F1B, /U1B, /W1B

Portable PC Card Recorder

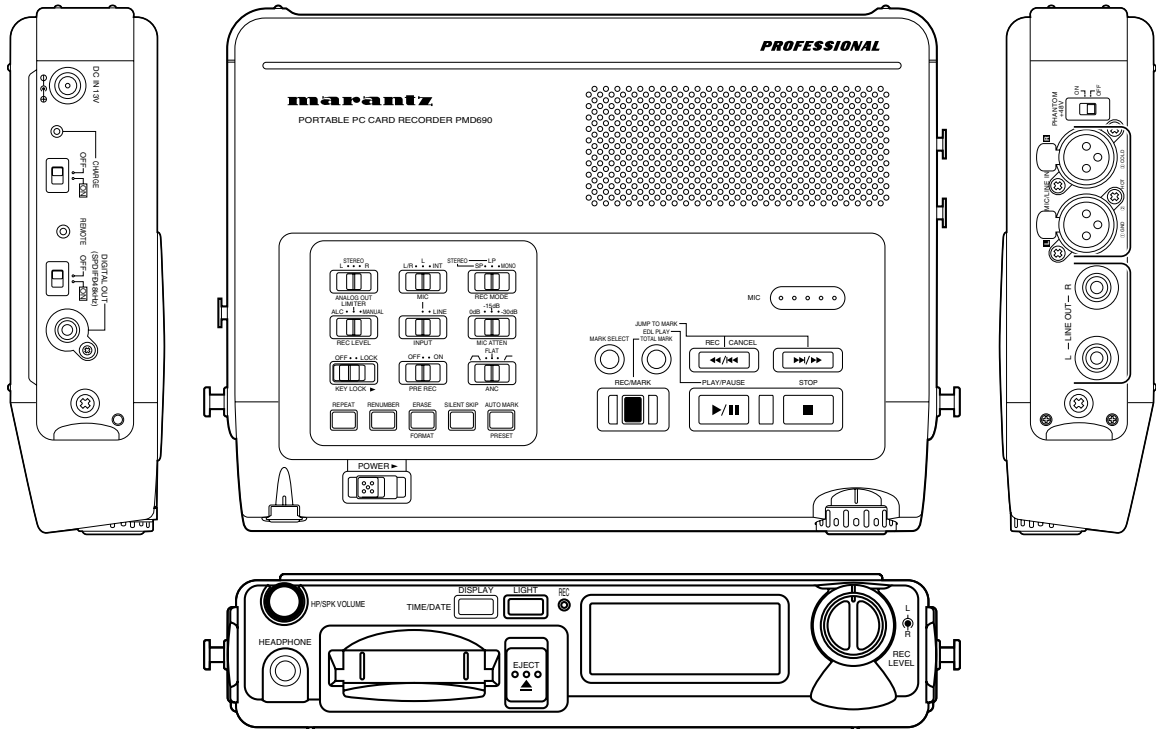

TABLE OF CONTENTS

SECTION	PAGE
1. TECHNICAL SPECIFICATIONS	1
2. WIRING DIAGRAM	3
3. BLOCK DIAGRAM	7
4. SCHEMATIC DIAGRAM.....	11
5. PARTS LOCATION.....	51
6. MICROPROCESSOR AND IC DATA.....	67
7. EXPLODED VIEW AND PARTS LIST	74
8. ELECTRICAL PARTS LIST	78

Please use this service manual with referring to the user guide (D.F.U.) without fail.
 修理の際は、必ず取扱説明書を準備し操作方法を確認の上作業を行ってください。

marantz®

PMD680 / PMD690

457S855010 MIT
 3120 785 22480
 First Issue 2001.06

PMD680 / PMD690

MARANTZ DESIGN AND SERVICE

Using superior design and selected high grade components, **MARANTZ** company has created the ultimate in stereo sound. Only original **MARANTZ** parts can insure that your **MARANTZ** product will continue to perform to the specifications for which it is famous.

Parts for your **MARANTZ** equipment are generally available to our National Marantz Subsidiary or Agent.

ORDERING PARTS :

Parts can be ordered either by mail or by Fax.. In both cases, the correct part number has to be specified.

The following information must be supplied to eliminate delays in processing your order :

1. Complete address
2. Complete part numbers and quantities required
3. Description of parts
4. Model number for which part is required
5. Way of shipment
6. Signature : any order form or Fax. must be signed, otherwise such part order will be considered as null and void.

USA

MARANTZ AMERICA, INC.
440 MEDINAH ROAD
ROSELLE, ILLINOIS 60172
USA
PHONE : 630 - 307 - 3100
FAX : 630 - 307 - 2687

EUROPE / TRADING

MARANTZ EUROPE B.V.
P.O.BOX 80002, BUILDING SFF2
5600 JB EINDHOVEN
THE NETHERLANDS
PHONE : +31 - 40 - 2732241
FAX : +31 - 40 - 2735578

BRAZIL

PHILIPS DA AMAZONIA IND. ELET. ITDA
CENTRO DE INFORMACOES AO
CEP 04698-970
SAO PAULO, SP, BRAZIL
PHONE : 0800 - 123123(Discagem Direta Gratuita)
FAX : +55 11 534. 8988

PROFESSIONAL AMERICAS

SUPERSCOPE TECHNOLOGIES, INC.
MARANTZ PROFESSIONAL PRODUCTS
2640 WHITE OAK CIRCLE, SUITE A
AURORA, ILLINOIS 60504 USA
PHONE : 630 - 820 - 4800
FAX : 630 - 820 - 8103

PROFESSIONAL AUSTRALIA

TECHNICAL AUDIO GROUP PTY, LTD
558 DARLING STREET,
BALMAIN, NSW 2041,
AUSTRALIA
PHONE : 61 - 2 - 9810 - 5300
FAX : 61 - 2 - 9810 - 5355

CANADA

LENBROOK INDUSTRIES LIMITED
633 GRANITE COURT,
PICKERING, ONTARIO L1W 3K1
CANADA
PHONE : 905 - 831 - 6333
FAX : 905 - 831 - 6936

AUSTRALIA

QualiFI Pty Ltd,
24 LIONEL ROAD,
MT. WAVERLEY VIC 3149
AUSTRALIA
PHONE : +61 - (0)3 - 9543 - 1522
FAX : +61 - (0)3 - 9543 - 3677

THAILAND

MRZ STANDARD CO.,LTD
746 - 754 MAHACHAI ROAD.,
WANGBURAPAPIROM, PHRANAKORN,
BANGKOK, 10200 THAILAND
PHONE : +66 - 2 - 222 9181
FAX : +66 - 2 - 224 6795

SINGAPORE

WO KEE HONG DISTRIBUTION PTE LTD
130 JOO SENG ROAD
#03-02 OLIVINE BUILDING
SINGAPORE 368357
PHONE : +65 858 5535 / +65 381 8621
FAX : +65 858 6078

NEW ZEALAND

WILDASH AUDIO SYSTEMS NZ
14 MALVERN ROAD MT ALBERT
AUCKLAND NEW ZEALAND
PHONE : +64 - 9 - 8451958
FAX : +64 - 9 - 8463554

TAIWAN

PAI- YUING CO., LTD.
6 TH FL NO, 148 SUNG KIANG ROAD,
TAIPEI, 10429, TAIWAN R.O.C.
PHONE : +886 - 2 - 25221304
FAX : +886 - 2 - 25630415

MALAYSIA

WO KEE HONG ELECTRONICS SDN. BHD.
SUITE 8.1, LEVEL 8, MENARA GENESIS,
NO. 33, JALAN SULTAN ISMAIL,
50250 KUALA LUMPUR, MALAYSIA
PHONE : +60 3 - 2457677
FAX : +60 3 - 2458180

JAPAN *Technical*

MARANTZ JAPAN, INC.
35- 1, 7- CHOME, SAGAMIONO
SAGAMIHARA - SHI, KANAGAWA
JAPAN 228-8505
PHONE : +81 42 748 1013
FAX : +81 42 741 9190

日本マランツ株式会社

本社 〒228-8505
神奈川県相模原市相模大野7-35-1
営業本部 〒150-0022
東京都渋谷区恵比寿南1-11-9

KOREA

MK ENTERPRISES LTD.
ROOM 604/605, ELECTRO-OFFICETEL, 16-58,
3GA, HANGANG-RO, YONGSAN-KU, SEOUL
KOREA
PHONE : +822 - 3232 - 155
FAX : +822 - 3232 - 154

SHOCK, FIRE HAZARD SERVICE TEST :

CAUTION : After servicing this appliance and prior to returning to customer, measure the resistance between either primary AC cord connector pins (with unit NOT connected to AC mains and its Power switch ON), and the face or Front Panel of product and controls and chassis bottom.

Any resistance measurement less than 1 Megohms should cause unit to be repaired or corrected before AC power is applied, and verified before it is return to the user/customer.

Ref. UL Standard No. 813.

In case of difficulties, do not hesitate to contact the Technical
Department at above mentioned address.

-- CAUTION !! --

The IC's (QS03, QU05, QU06) replacement

In case of replace these IC's, please confirm the product type number, the parts code number and the LOT number.

IC's QS03, QU05 and QU06 must be replaced all three of those together.

LOT No.	PMD680		
	QS03	QU05	QU06
01 - 06	*HS457SH0R	*HS457SK0R	*HS457SK1R
07 -	HS470SH00F or 9965 000 08937	HS470SO00F or 9965 000 08992	HS470SO10F or 9965 000 08993

LOT No.	PMD690		
	QS03	QU05	QU06
01, 02	*HS470SH0R	*HS470SK 0R	*HS470SK1R
03 -	HS470SH00F or 9965 000 08937	HS470SO00F or 9965 000 08992	HS470SO10F or 9965 000 08993

REMARK : IC's which have MJI ten digit code number are available from MJI "SPARE PARTS SUPPLY SECTION" only.

*HS457SH0R, *HS457SK0R, *HS457SK1R,
*HS470SH0R, *HS470SK0R, *HS470SK1R,

[REMARK]

The LOT number is mentioned in the serial number label on the rear panel.
(ex. MZxxxxxx01xxxx : LOT No. 01)

1. TECHNICAL SPECIFICATIONS (PMD680 only)

Digital audio system

- System
 - Digital audio recorder
- Usable Media
 - Approved PCMCIA PC Cards
- Recording and reading method
 - MPEG1 Layer II compression
 - 16 bit linear PCM
- Recording Bit rate (Selectable by preset)
 - LP (Long Play mode)
 - 128, 64, 48, 32 kbps (MPEG)
 - MP (Medium Play mode)
 - 192, 128, 64, 48 kbps (MPEG)
 - SP (Standard Play mode)
 - 768 kbps (PCM), 192, 128, 64 kbps (MPEG)

The amount of memory required per hour of recording:

Bit Rate (kbps)	MB/Hour
32	16 MB
48	25 MB
64	33 MB
128	67 MB
192	100 MB
768 (PCM)	400 MB

- Sampling frequency
 - 48 kHz
- Number of channels
 - 1 (mono)
- Frequency Response
 - 22,000 Hz \pm 0.5 dB (at digital)
- Signal-to-Noise Ratio (IEC-A weighted)
 - 80 dB
- Total Harmonic Distortion (at 0 VU)
 - 0.03 %
- Dynamic Range
 - 85dB

Inputs

- MIC IN 1 (1:GND, 2:HOT, 3:COLD)
 - Type: XLR
 - Input Sensitivity: -68 dBu/9 kohm
- MIC IN 2
 - Type: 1/4" jack
 - Sensitivity: -68 dBu/9 kohm
- LINE IN
 - Type: RCA jack
 - Sensitivity: -20 dBu/47 kohm
- TELEPHONE IN/OUT
 - Type: RJ-11/14 jack
 - Standard input level: 0.5 Vp-p
 - Standard output level: 0.24 Vp-p
 - Input impedance: 1.6 kohm
 - Output impedance: 720 ohm

Outputs

- LINE OUT
 - Type: RCA jack
 - Standard level: 2 Vrms max./2 kohm
- DIGITAL OUT
 - Type: RCA jack
 - Output impedance: 75 ohm
 - Standard output level: 0.5 Vp-p
 - Sampling frequency: 48 kHz
 - Format: SPDIF (IEC-958 Type II)

GENERAL

- Headphone Output power
 - 15 mW/32 ohm
- Speaker Output Power
 - 200 mW
- Power Requirement
 - 13 V, 1.0 A
- Power Consumption
 - Recording: 5.2 W
 - Charging: 12 W
 - Power off: 10 mW
- Dimensions (W x H x D)
 - 264 x 52 x 185 mm
 - (10.4" x 2.0" x 7.3")
- Weight
 - 1.3 kg (2 lbs. 14 oz.)
- Included Accessories
 - AC adaptor: 1
 - Battery holder: 1
 - Carrying Strap: 1
 - User Guide: 1
- Optional Accessories
 - Ni-Cad Battery pack (RB1100PMD)
 - Carrying Case (CLC680PMD)

Specifications subject to change without notice.

1. TECHNICAL SPECIFICATIONS (PMD690 only)

Digital audio system

System

Digital audio recorder

Usable Media

Approved PCMCIA PC Cards and HDD cards

Recording and reading method

MPEG1 Layer II compression

16 bit linear PCM

Recording Bit rate (Selectable by preset)

MONO

768 kbps (PCM), 192, 128, 96, 64, 48, 32 kbps (MPEG)

LP (Long Play mode, Stereo)

192, 128, 96, 64 kbps (MPEG, Joint Stereo)

SP (Standard Play mode, Stereo)

1536 kbps (PCM), 384, 256 kbps (MPEG, Joint Stereo)

The amount of memory required for one hour of recording:

Bit Rate (kbps)	MB/Hour
32	16 MB
48	25 MB
64	33 MB
96	50 MB
128	67 MB
192	100 MB
256	136 MB
384	200 MB
768 (PC1, PCM Mono)	400 MB
1536 (PC2, PCM Stereo)	800 MB

Sampling frequency

48 kHz

Number of channels

2/1 (stereo/mono)

Frequency Response

22,000 Hz \pm 0.5 dB (at digital)

Signal-to-Noise Ratio (IEC-A weighted)

80 dB

Total Harmonic Distortion (at 0 VU)

0.03 %

Dynamic Range

85dB

Inputs

MIC/LINE IN L/R

Type: XLR (1:GND, 2:HOT, 3:COLD)

Input Sensitivity (MIC): -68 dBu/9 kohm

Input Sensitivity (LINE): -20 dBu/47 kohm

Outputs

LINE OUT L/R

Type: RCA jack

Standard level: 2 Vrms max./2 kohm

DIGITAL OUT

Type: RCA jack

Output impedance: 75 ohm

Standard output level: 0.5 Vp-p

Sampling frequency: 48 kHz

Format: SPDIF (IEC-958 Type II)

GENERAL

Headphone Output power

15 mW/32 ohm

Speaker Output Power

200 mW

Phantom Power

+48V, 5mA

Power Requirement

13 V, 1.0 A

Power Consumption

Recording: 5.2 W

Charging: 12 W

Power off: 10 mW

Dimensions (W x H x D)

264 x 52 x 185 mm

(10.4" x 2.0" x 7.3")

Weight

1.3 kg (2 lbs. 14 oz.)

Included Accessories

Battery holder: 1

Carrying Strap: 1

User Guide: 1

Optional Accessories

AC adaptor (DA600)

Ni-Cad Battery pack (RB1100PMD)

Carrying Case (CLC690PMD)

2. WIRING DIAGRAM

PMD680 only

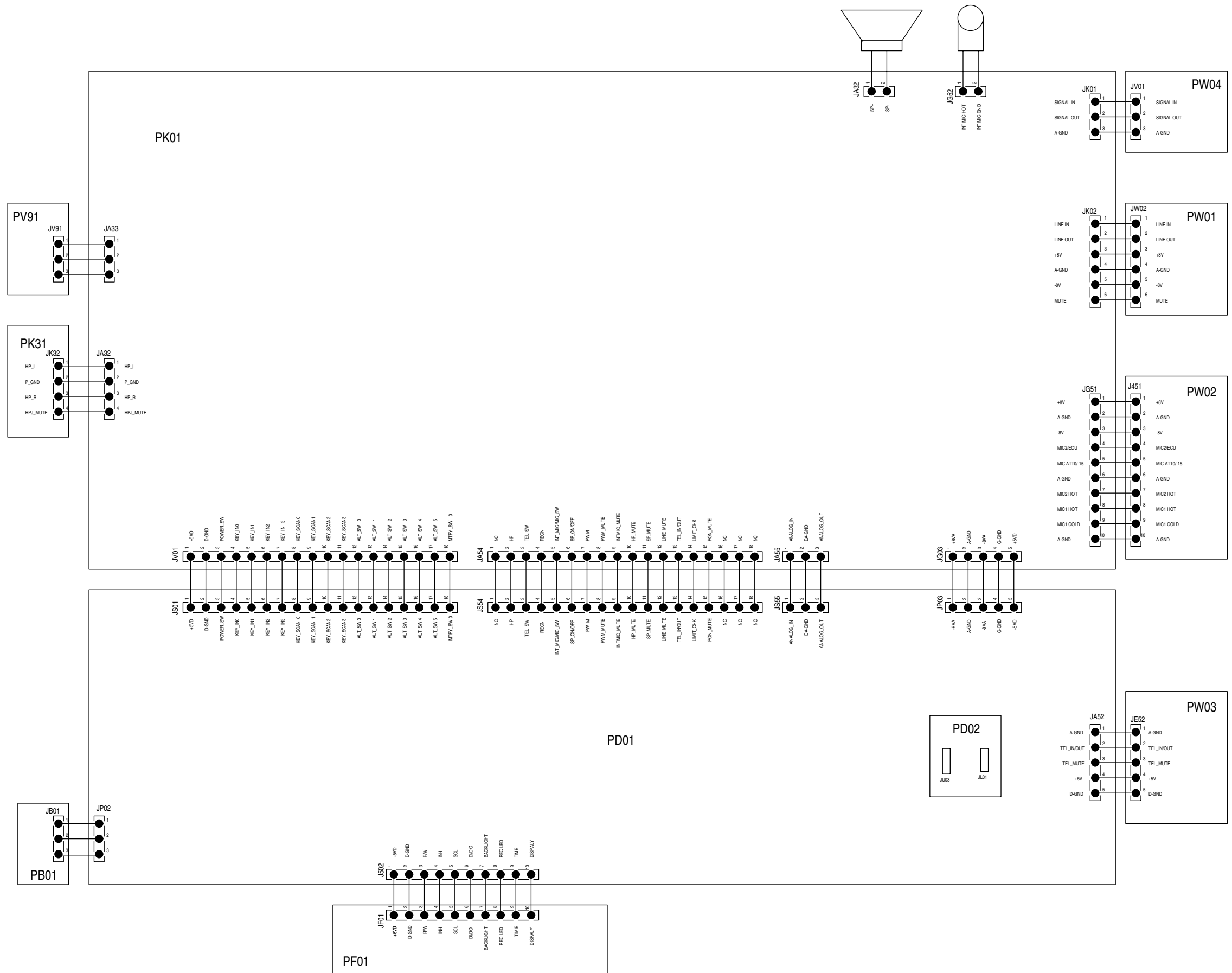

PMD690 only

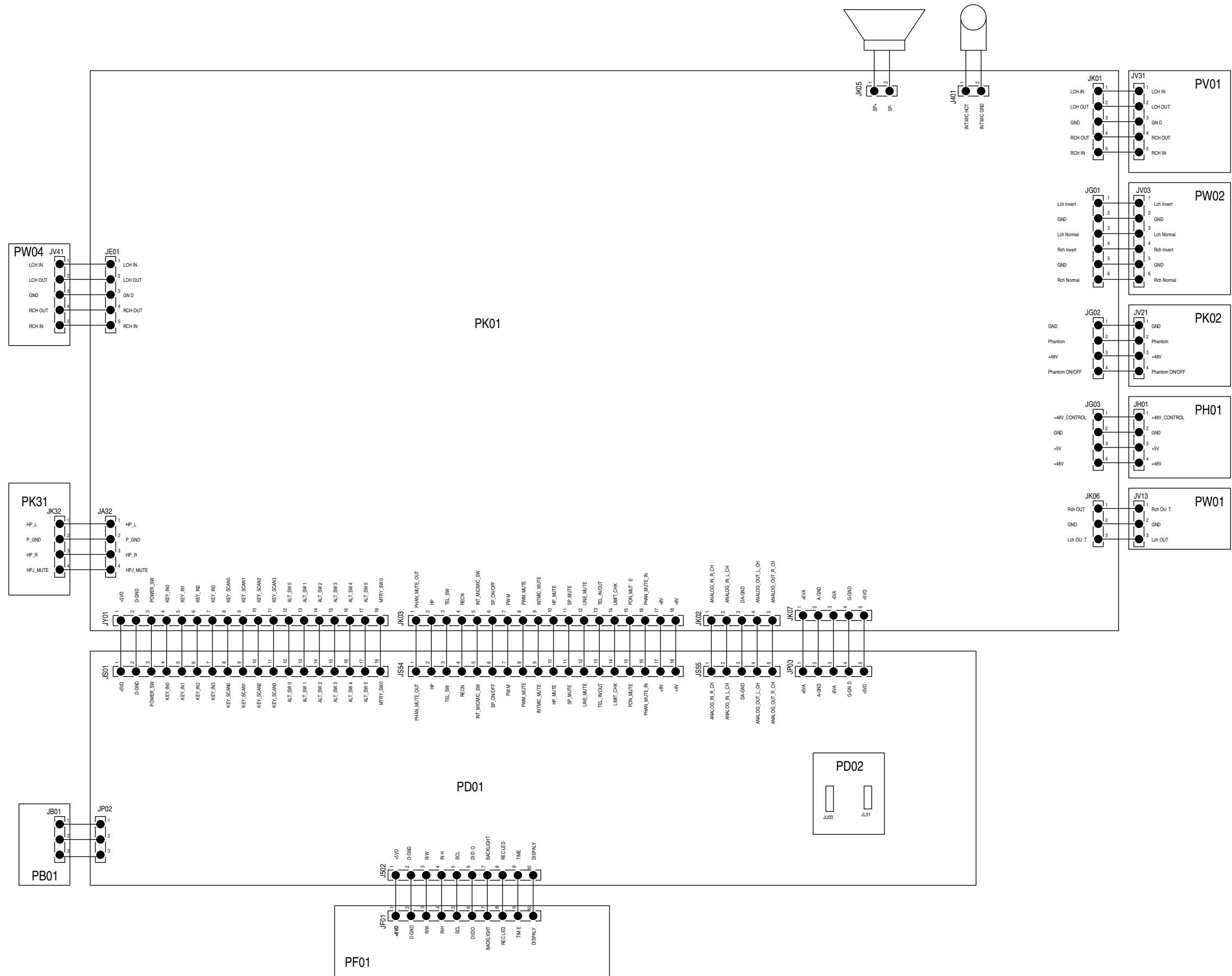

3. BLOCK DIAGRAM

PMD680 only

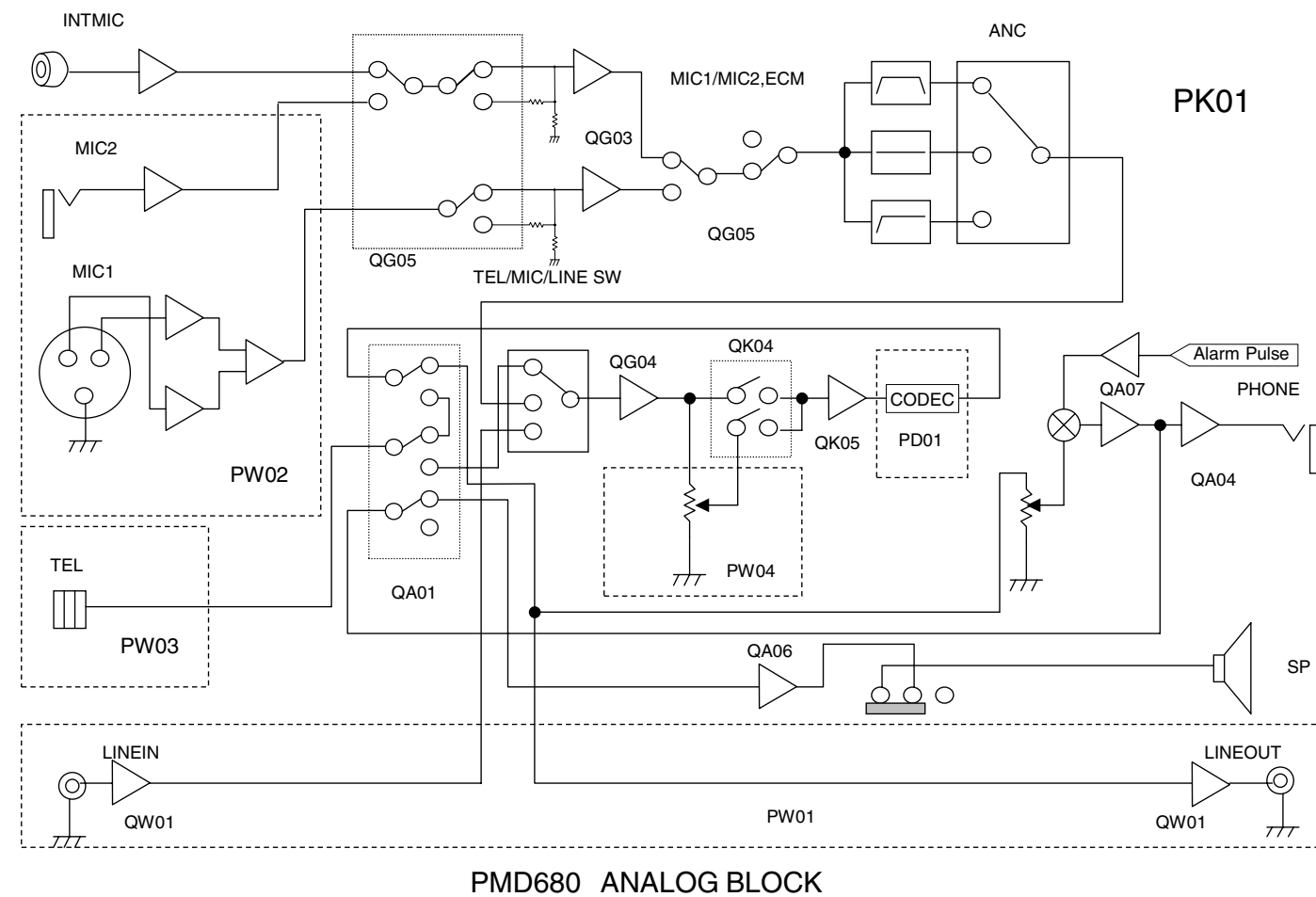
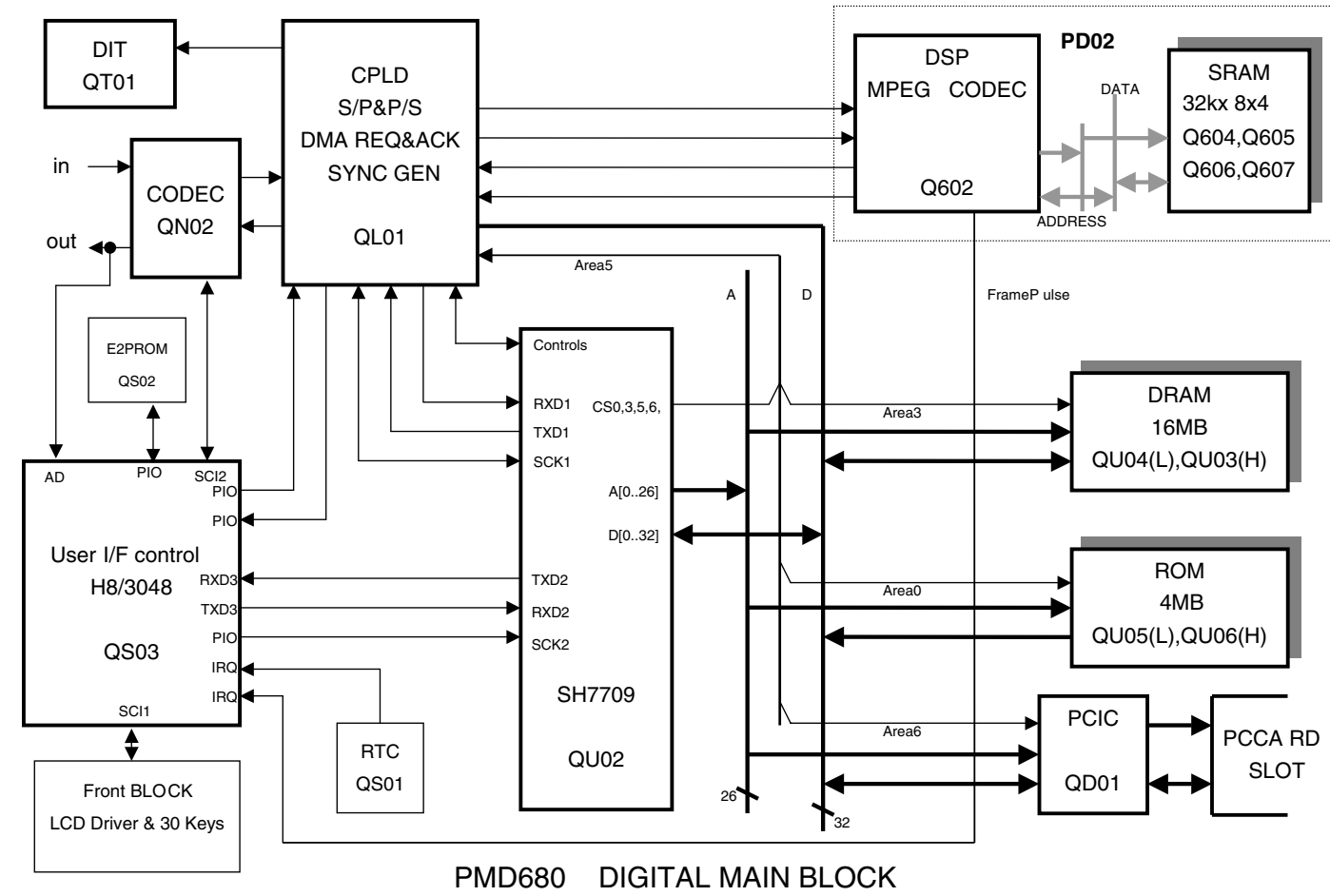

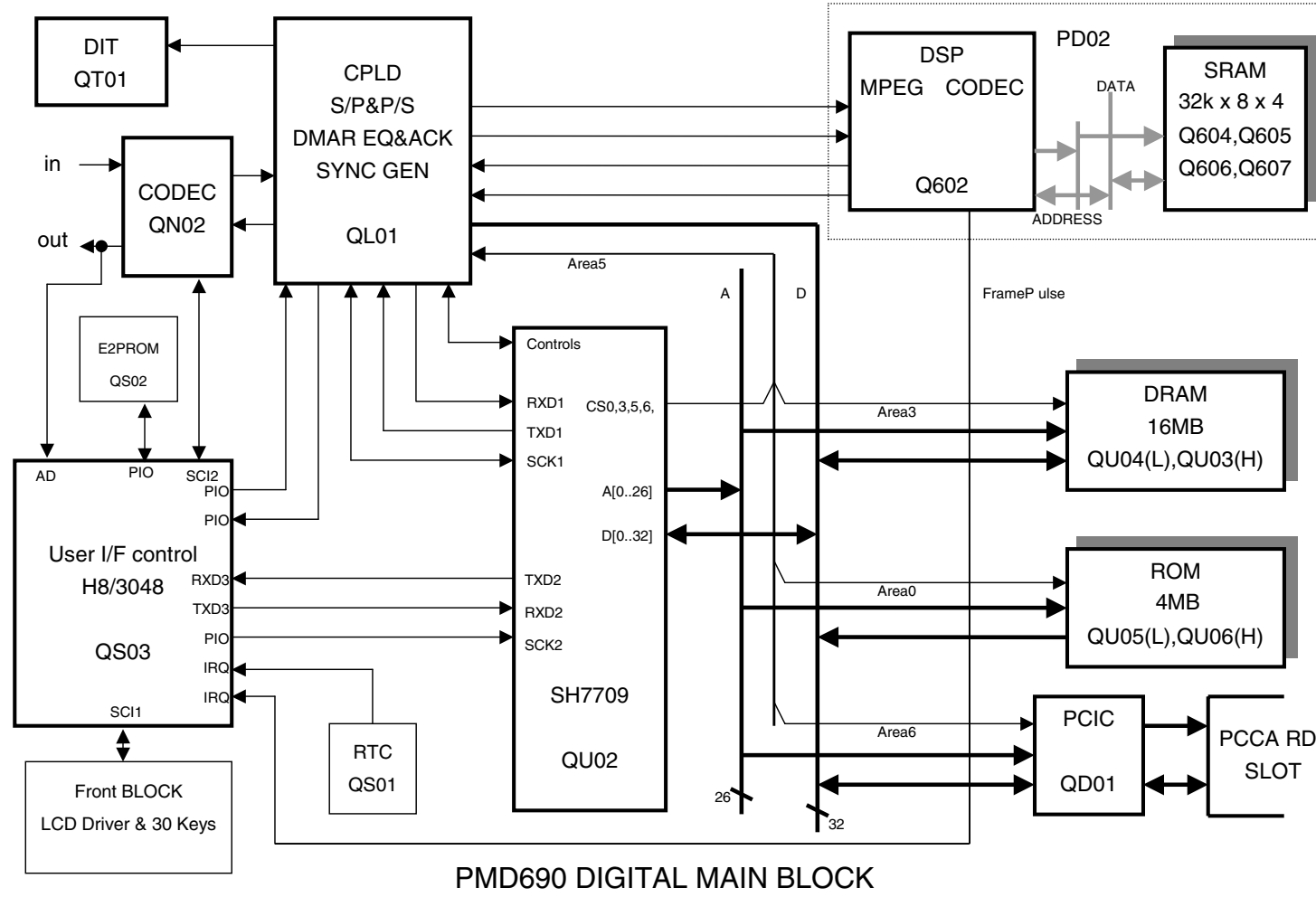

PMD690 DIGITAL MAIN BLOCK

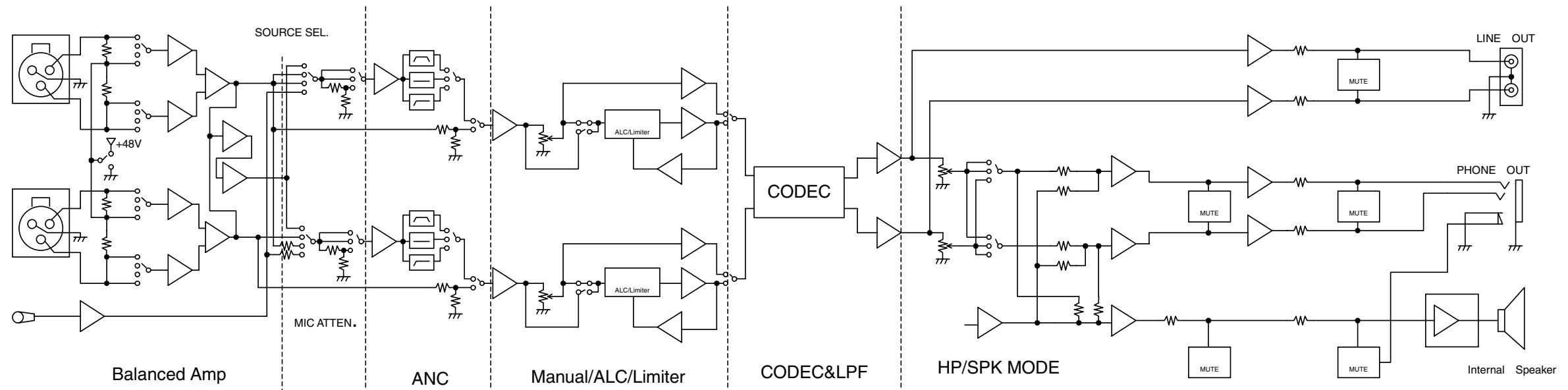

PMD690 ANALOG BLOCK

4. SCHEMATIC DIAGRAM

LSYM:LCA
KSYM:PD01

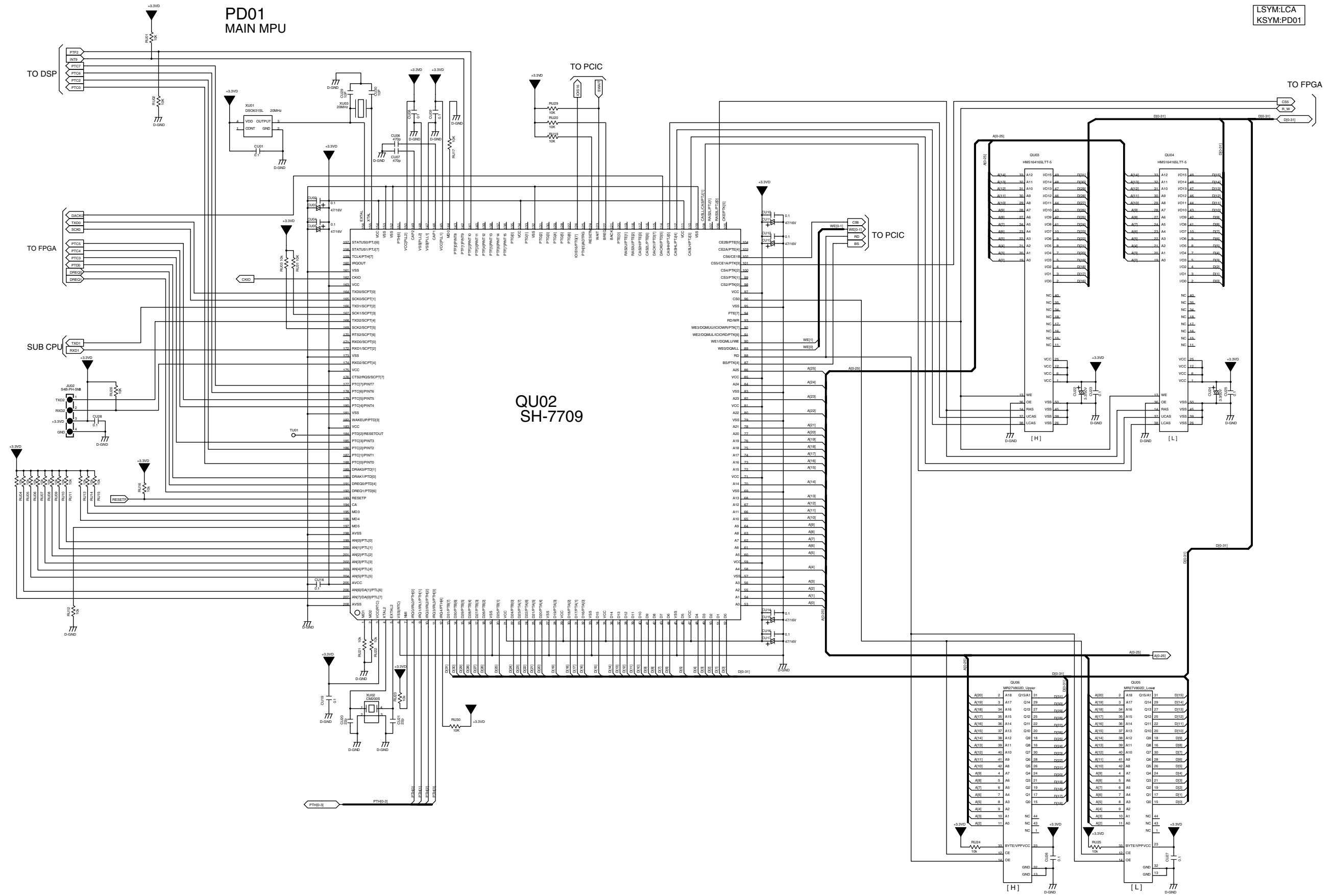

PD01
SUB MPU(H8)

LSYM:LCB
KSYM:PD01

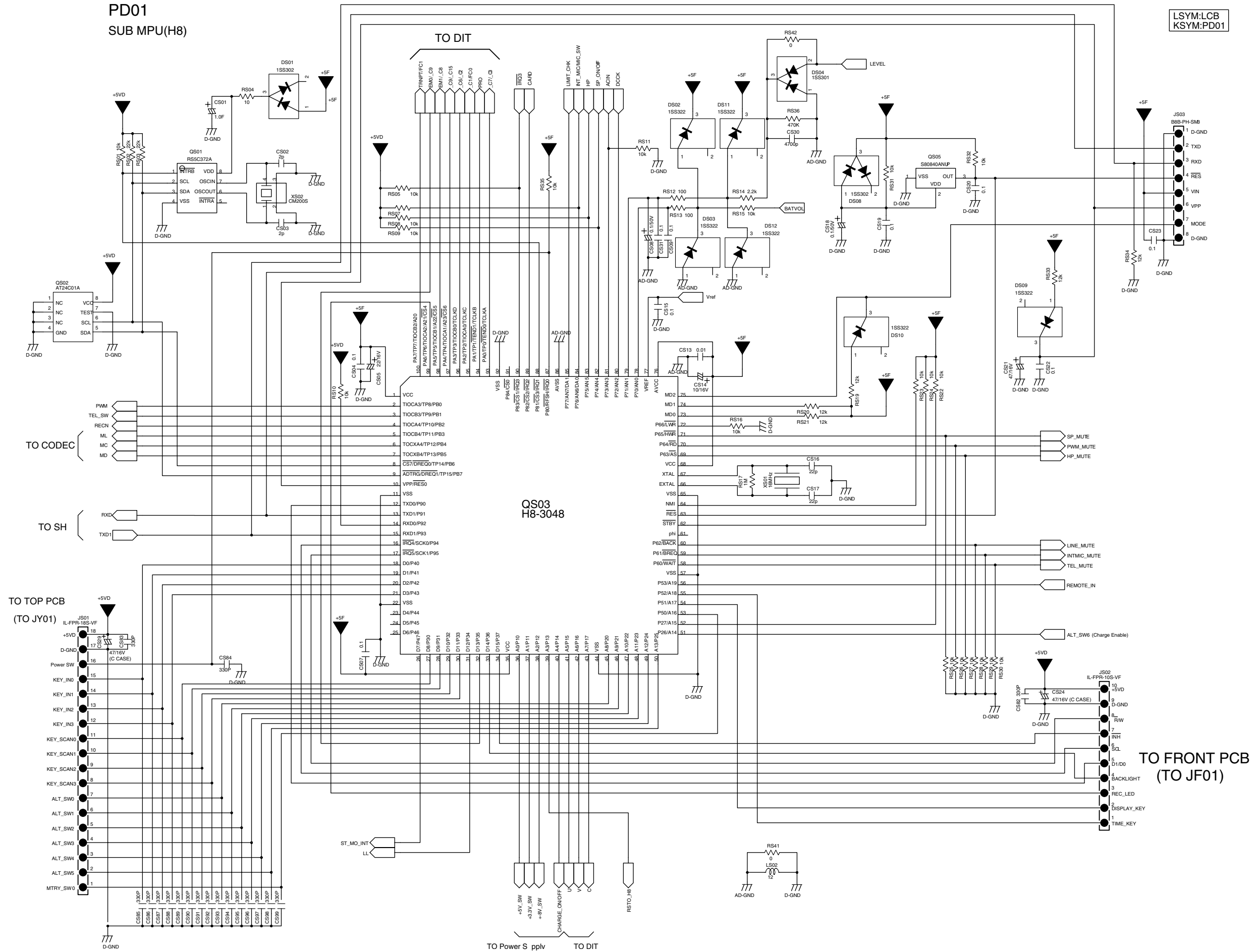

PD01
FPGA

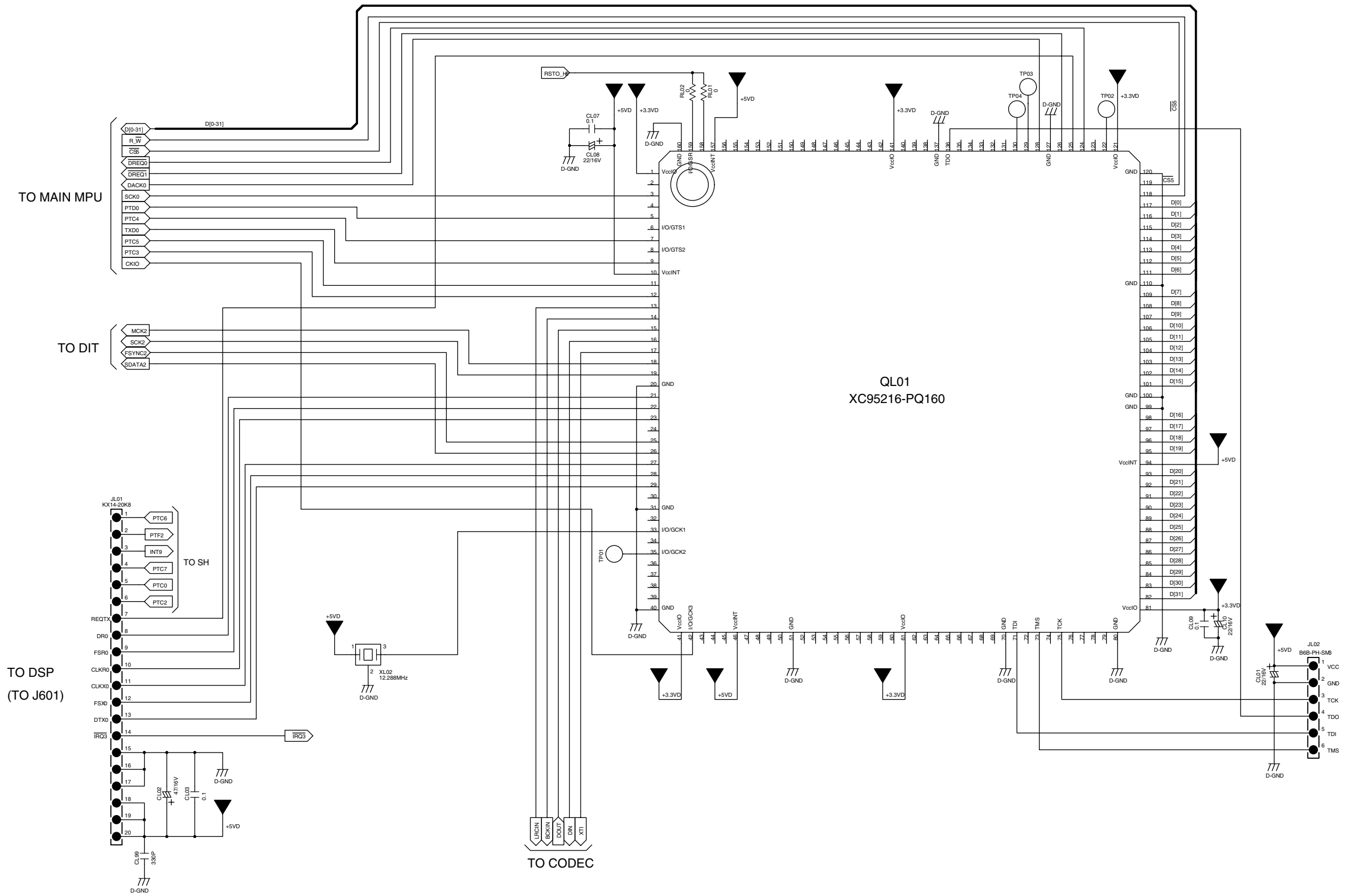

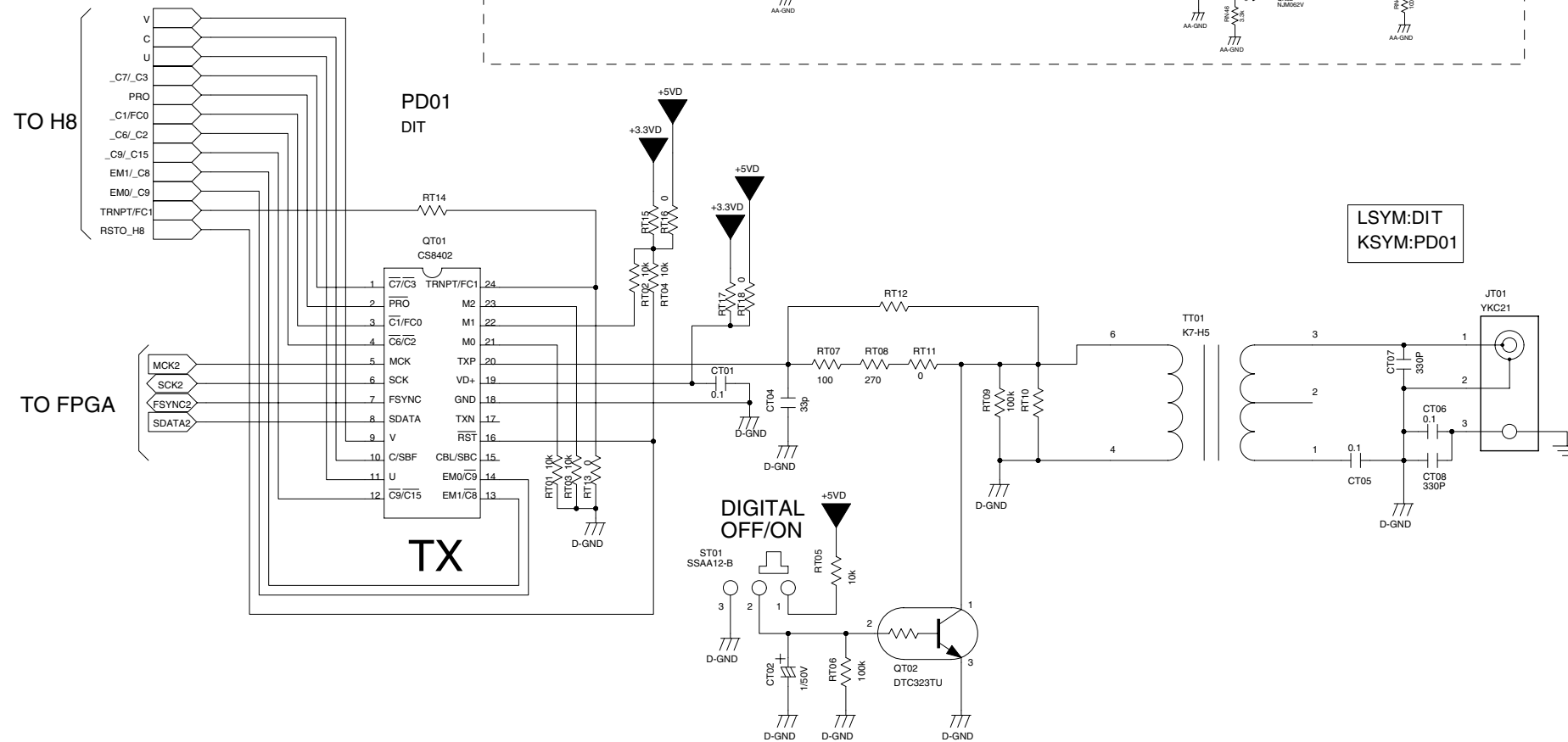
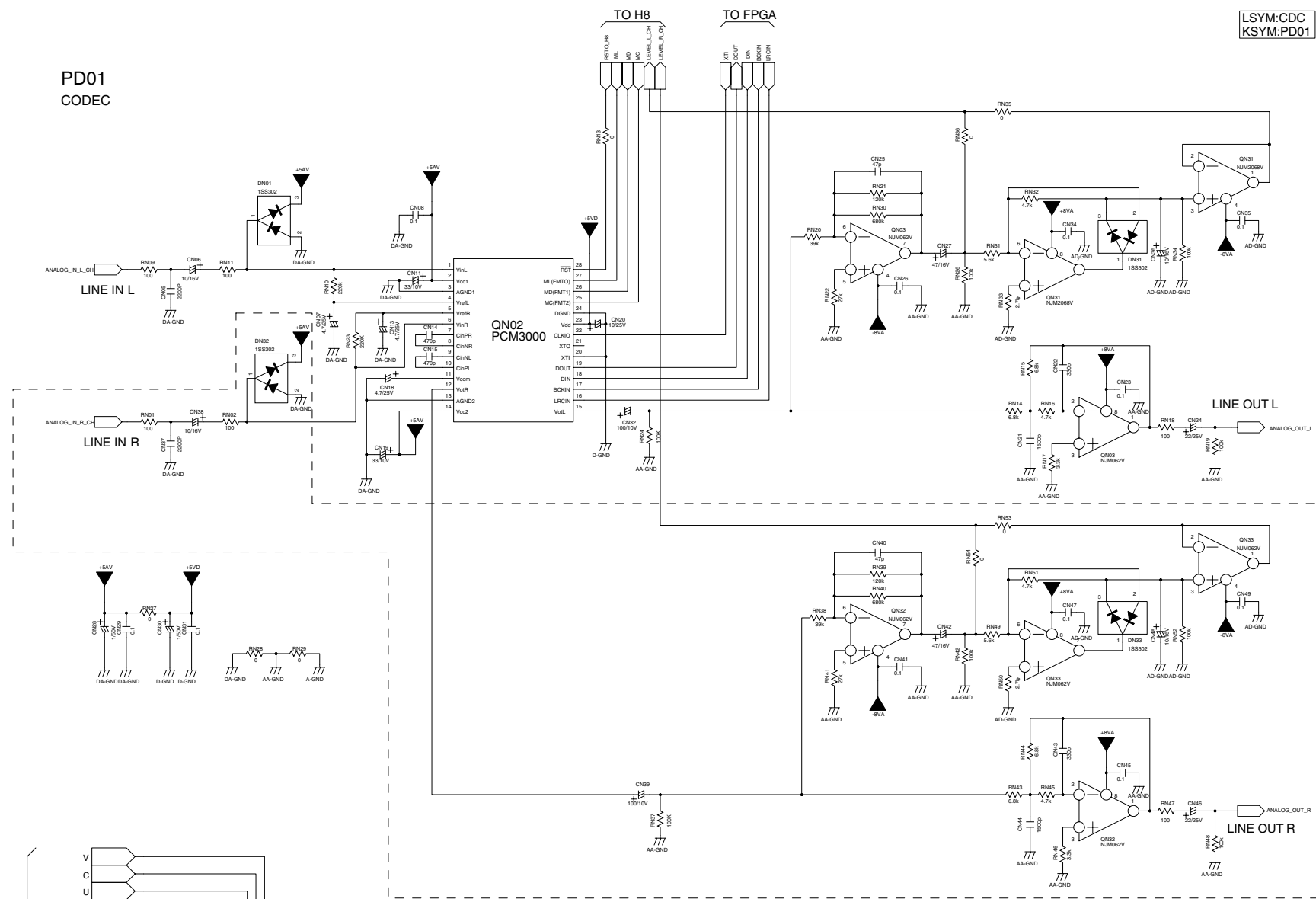

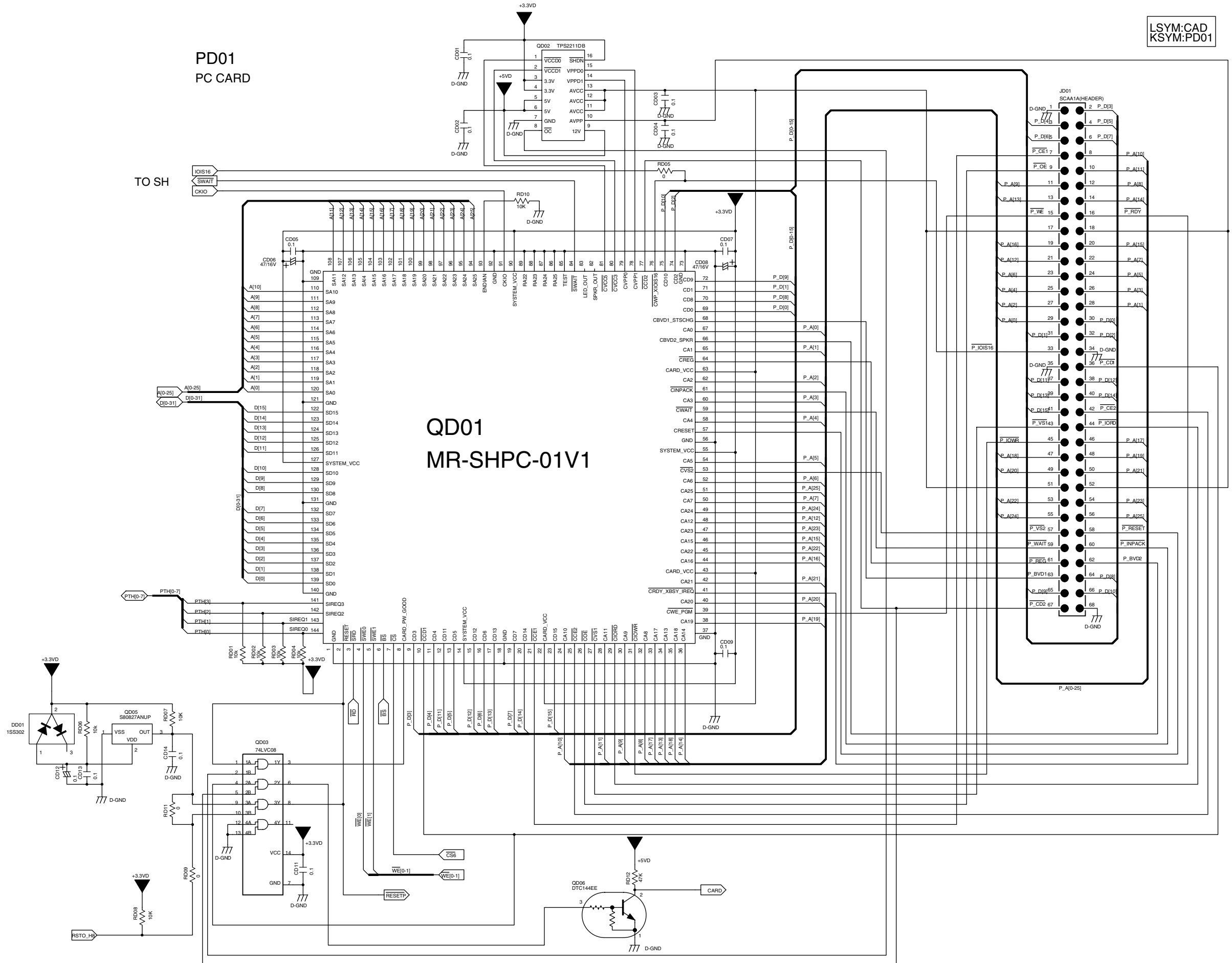

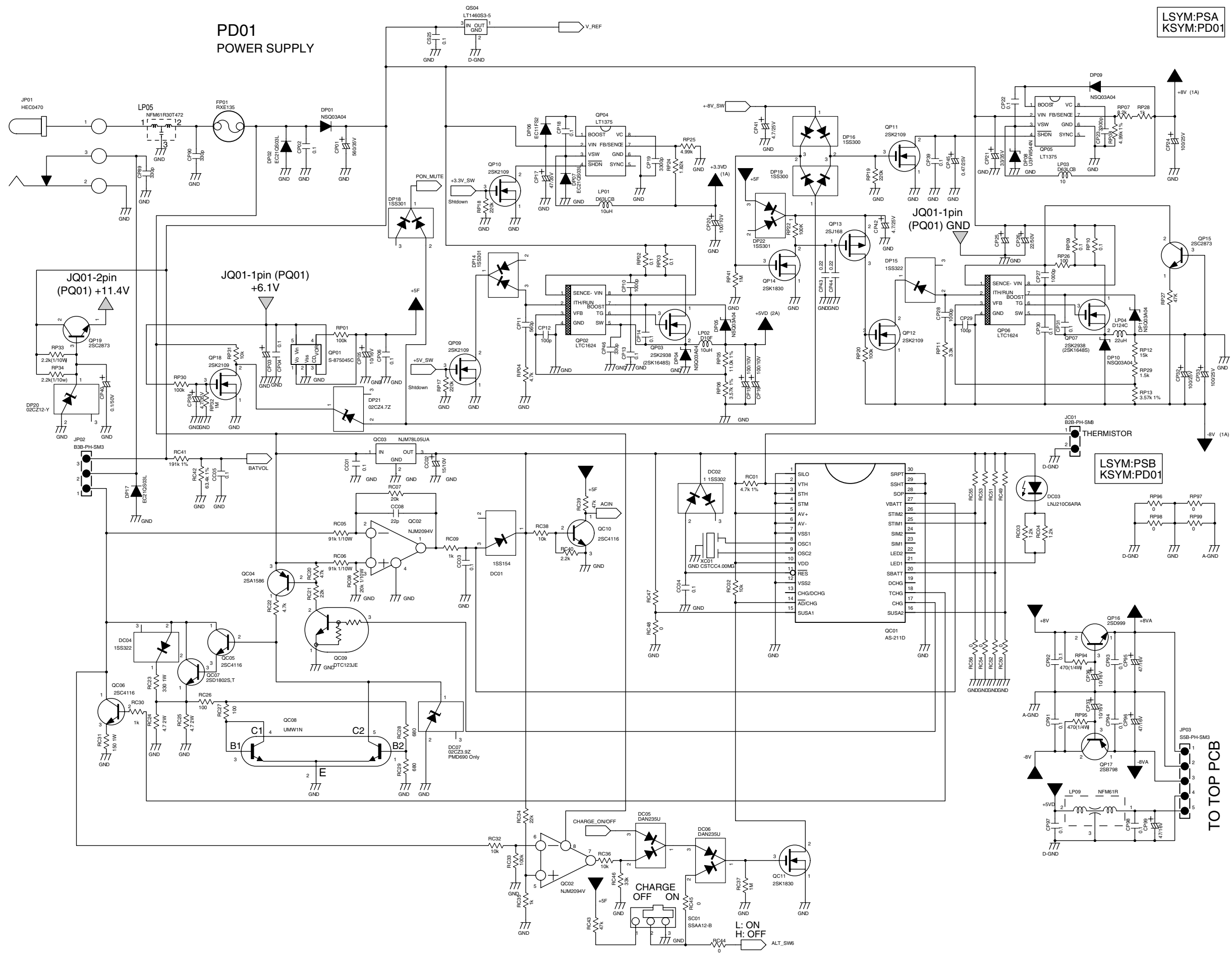

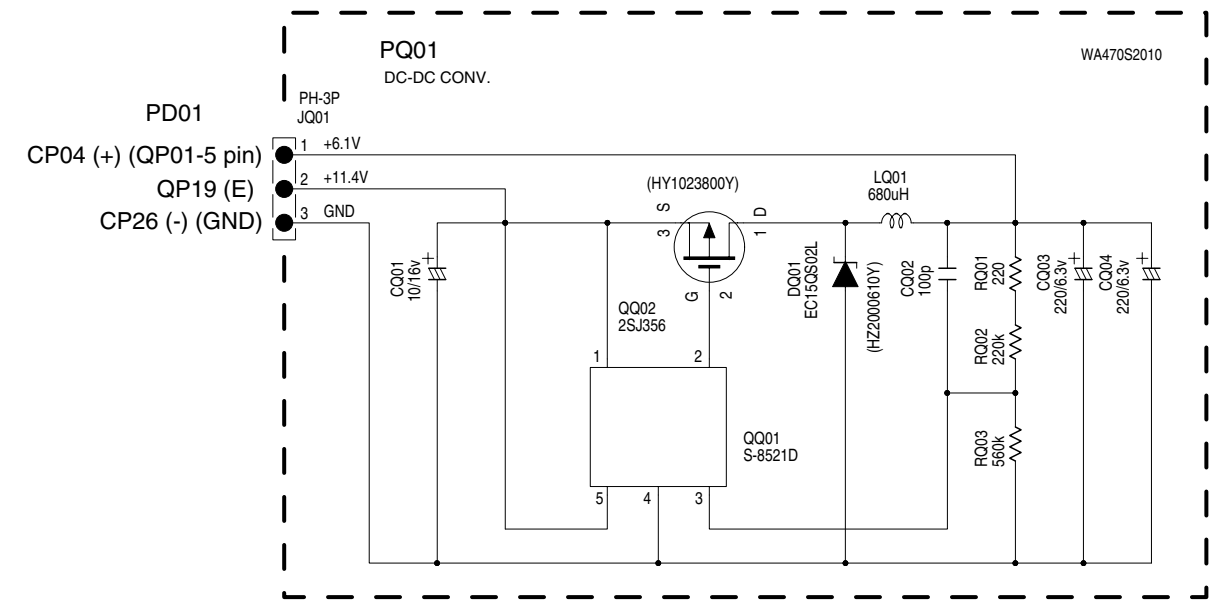
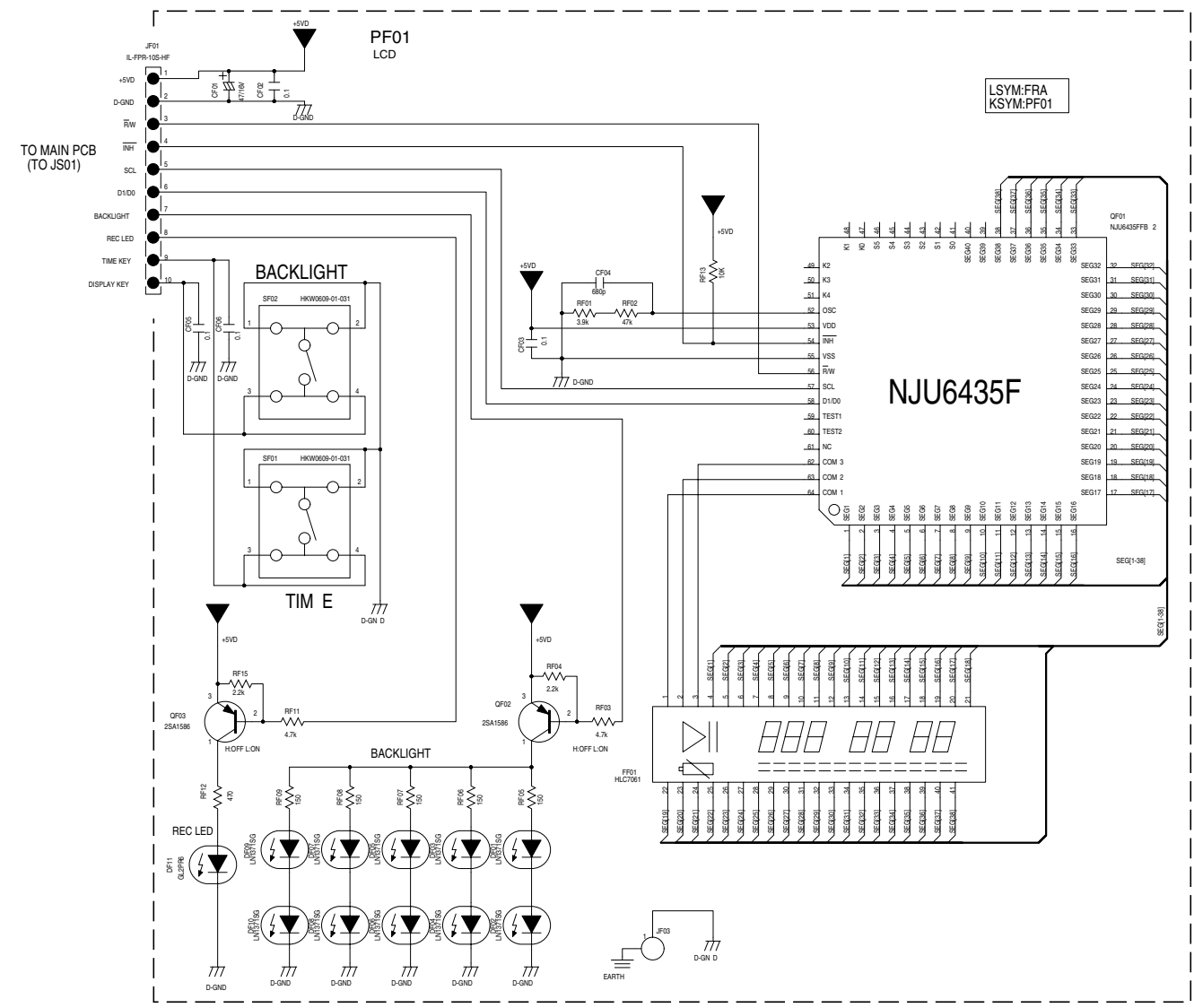
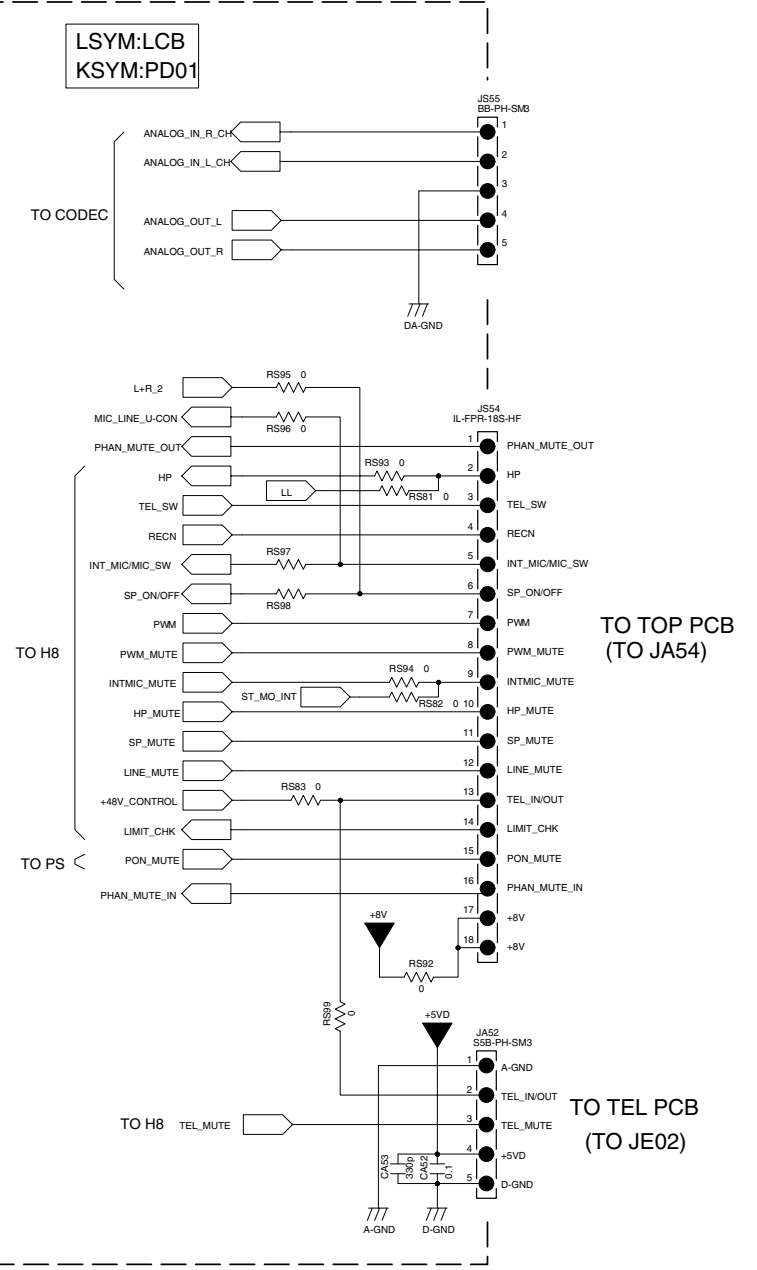
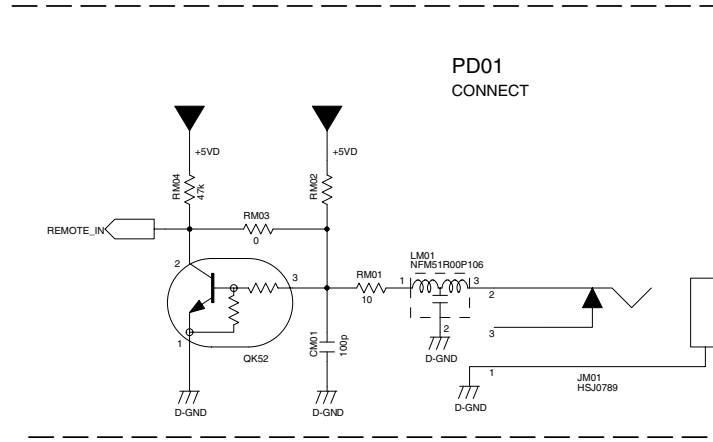

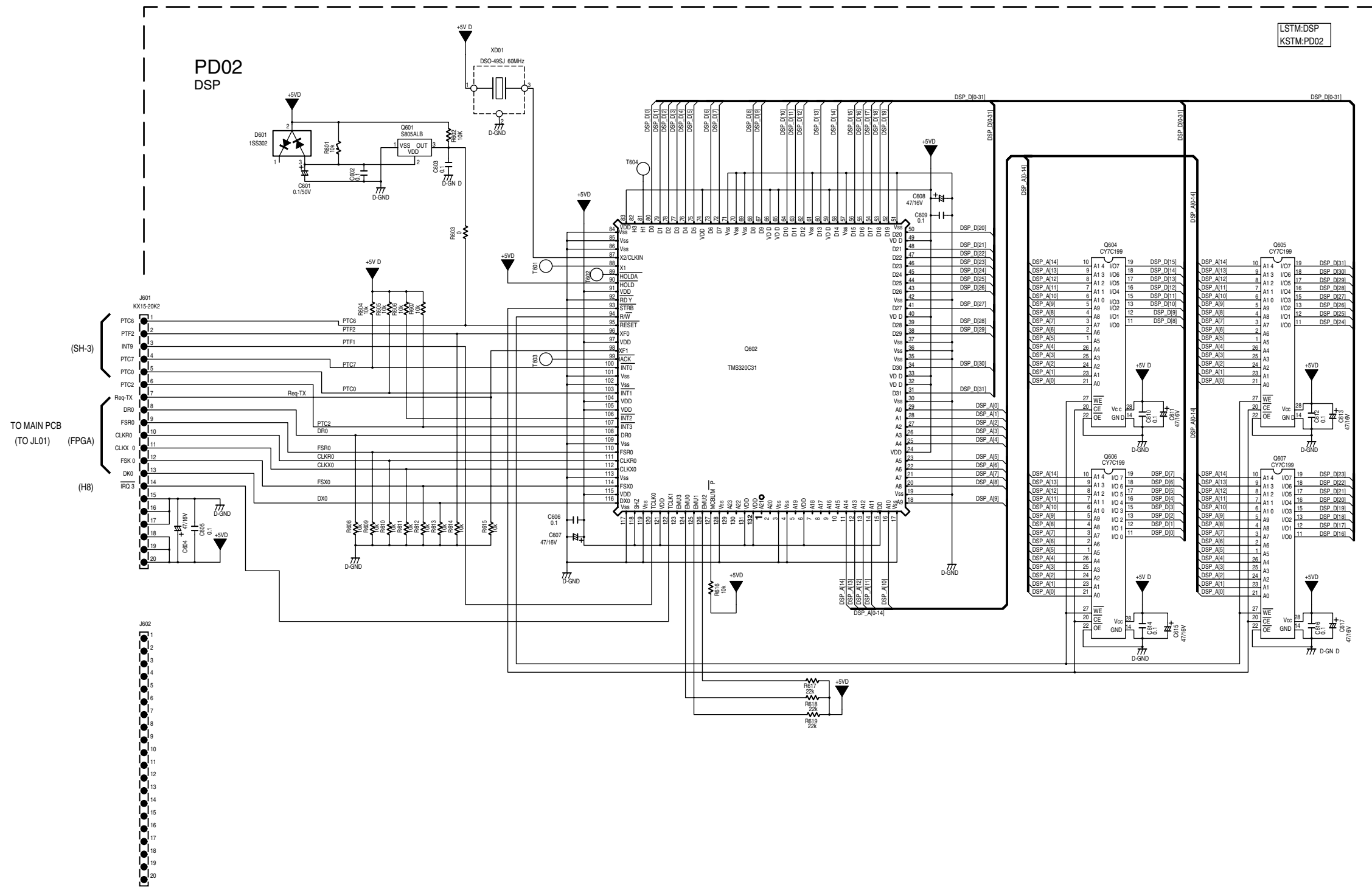

LSTM:DSP
KSTM:PD02

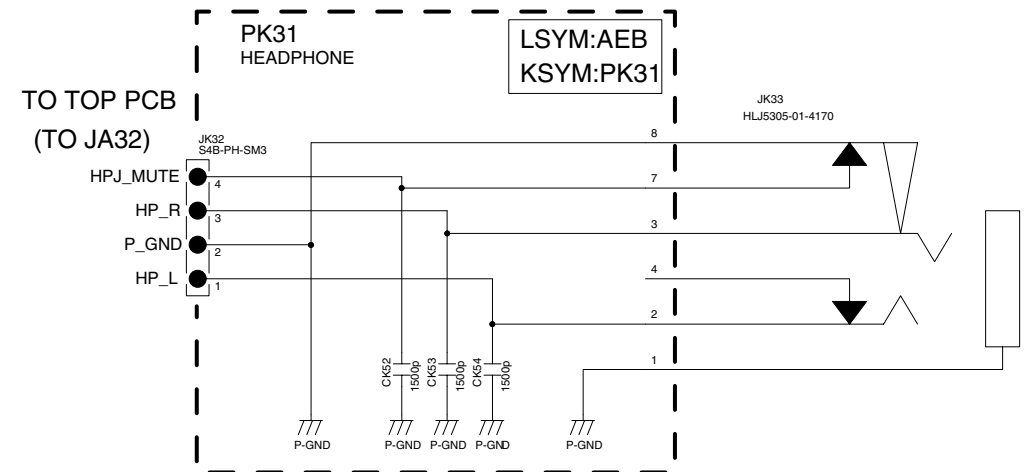
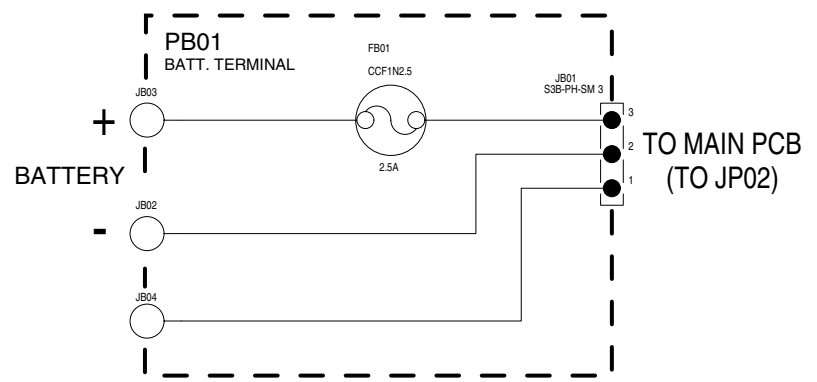

PMD680 only

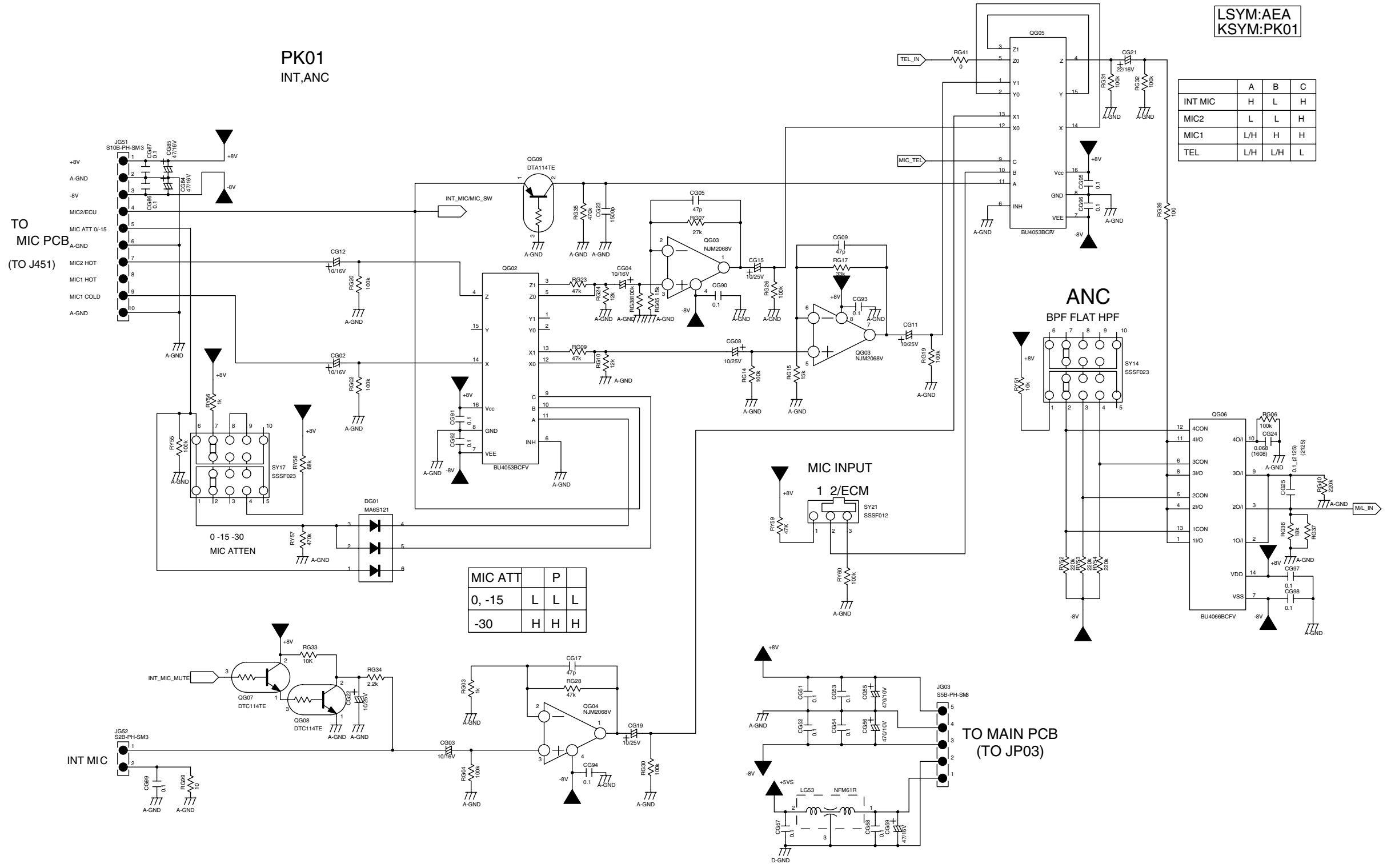

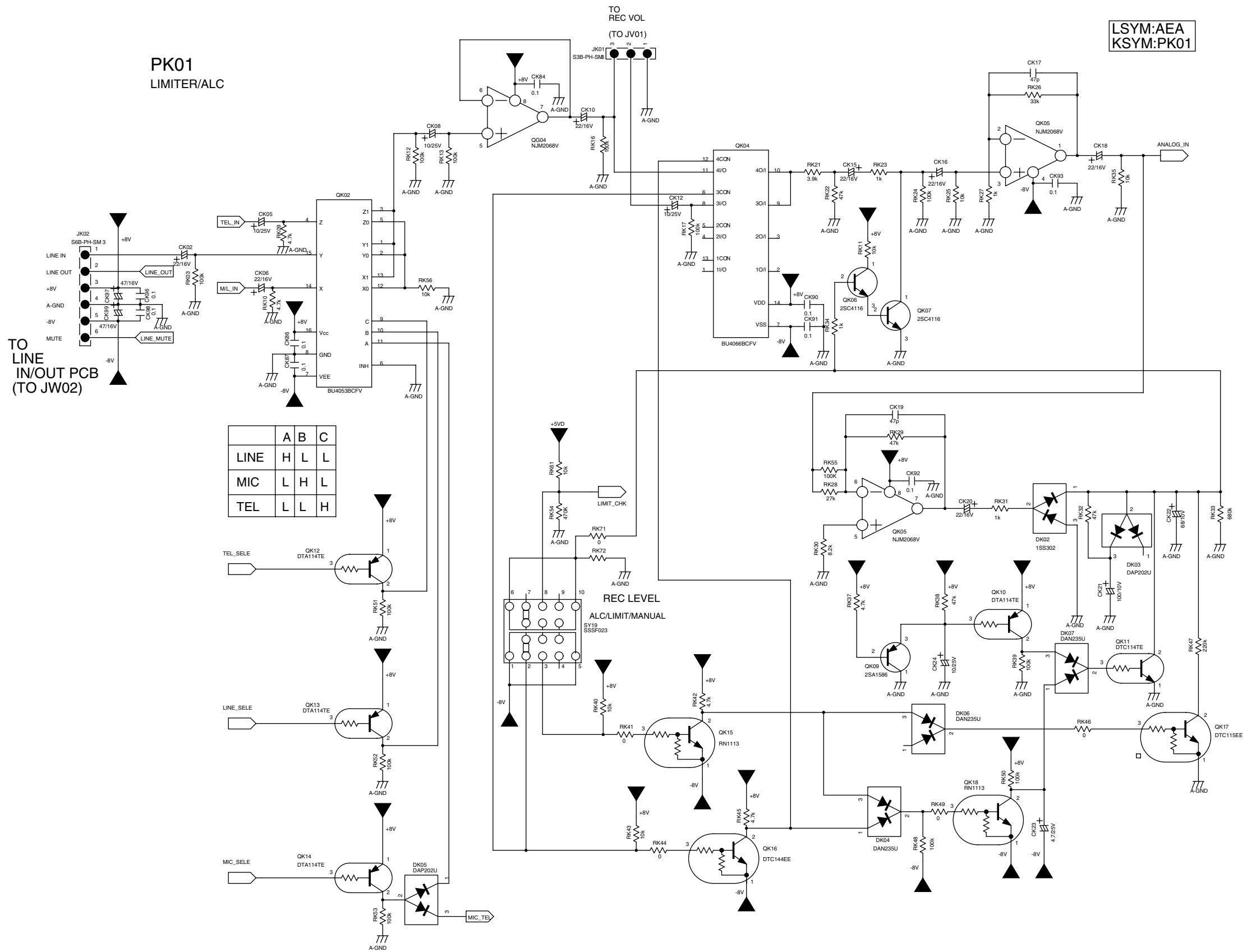

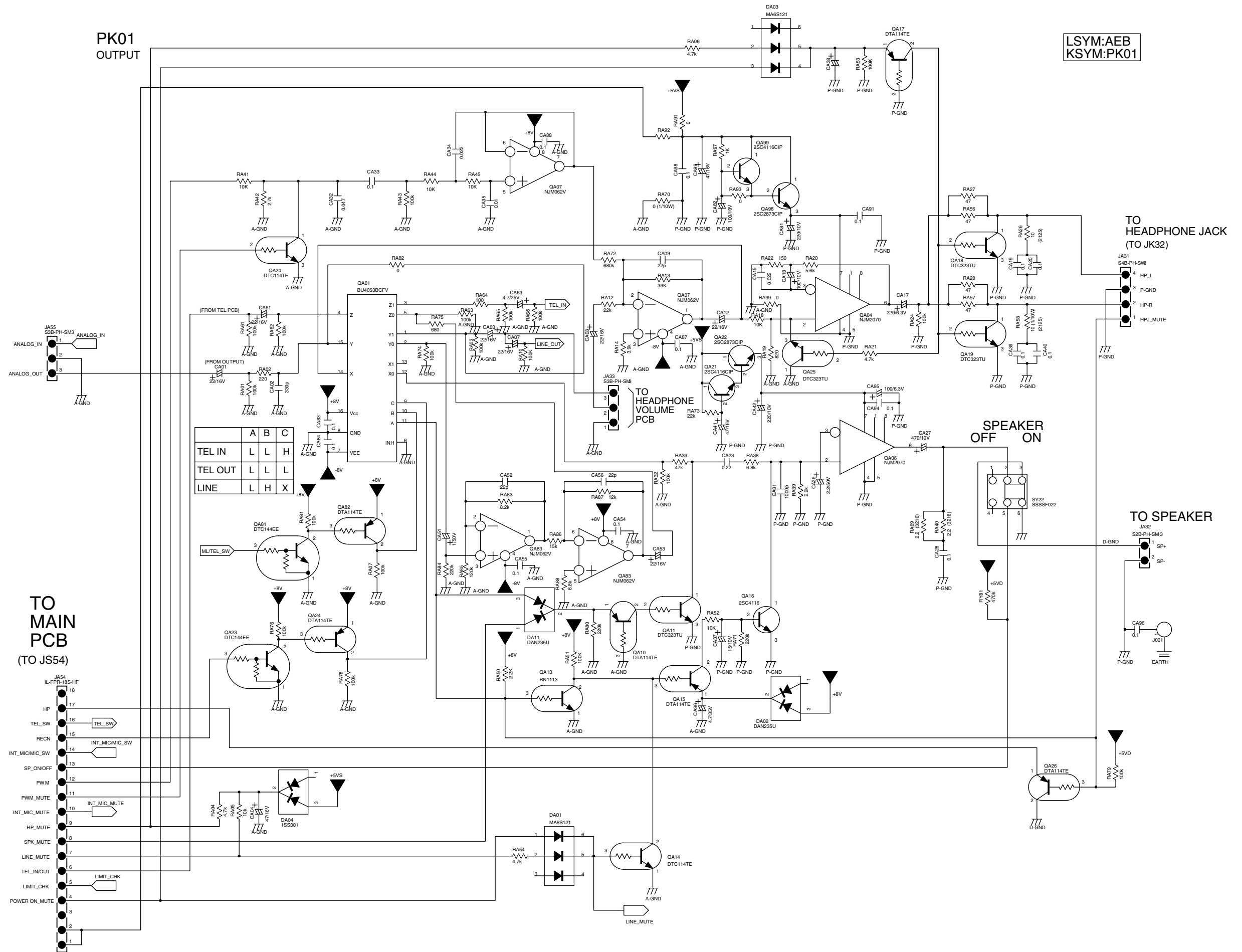

LSYM:AEB
KSYM:PK01

PK01
OUTPUT

TO HEADPHONE JACK
(TO JK32)

SPEAKER OFF
ON

TO SPEAKER

TO MAIN PCB
(TO JS54)

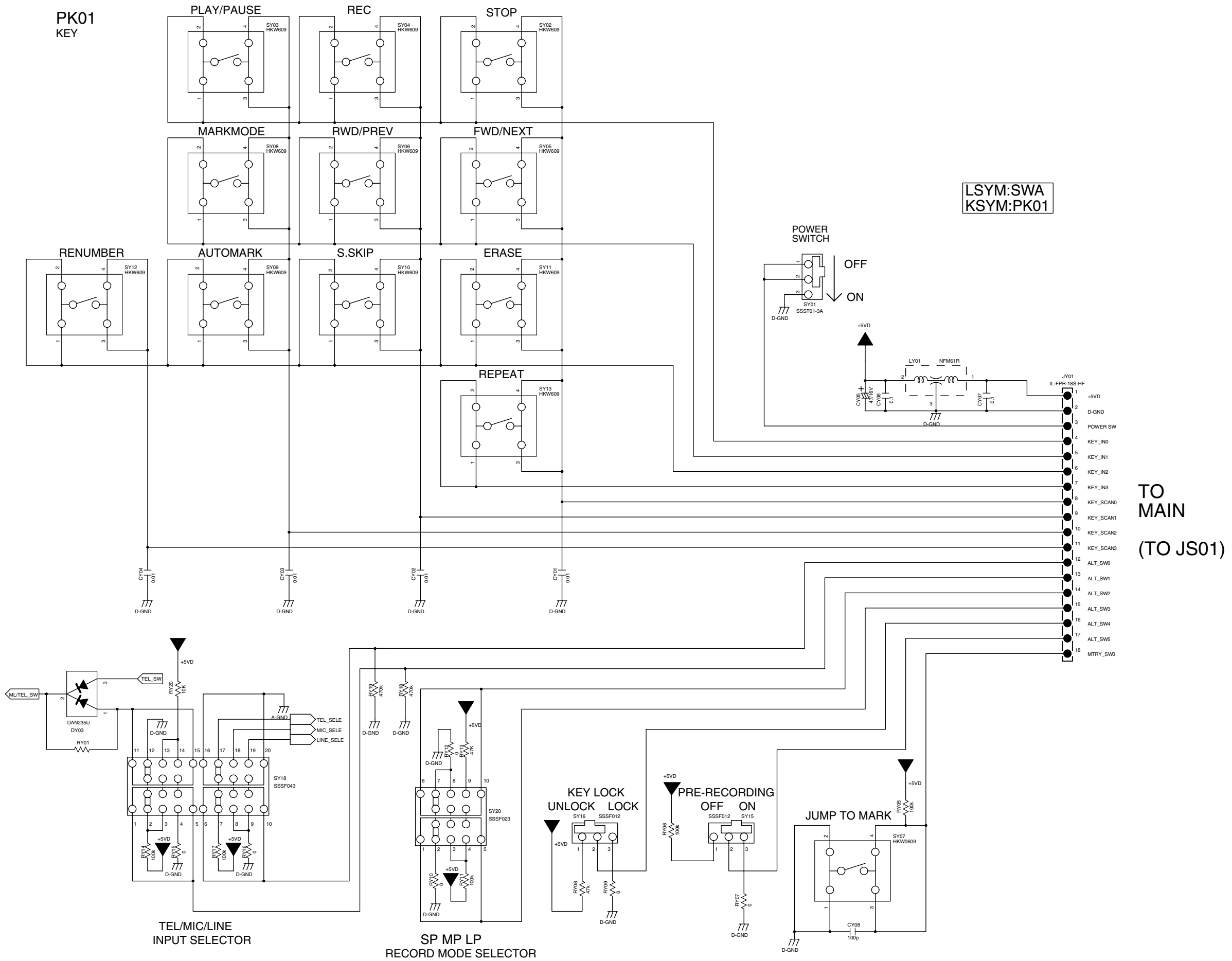

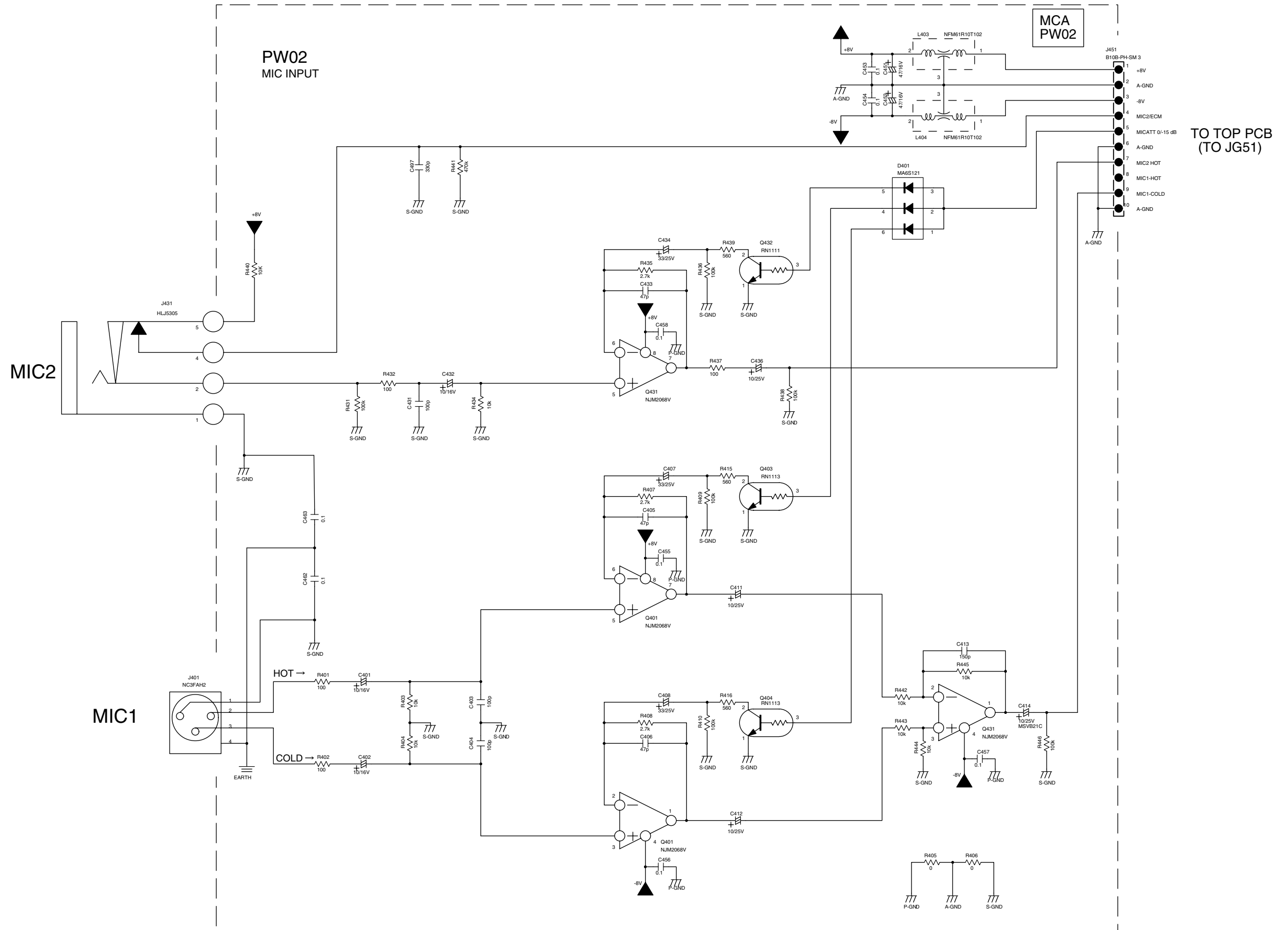

PMD680 only

PW03
TEL IN/OUT

TO MAIN PCB
(TO JA52)

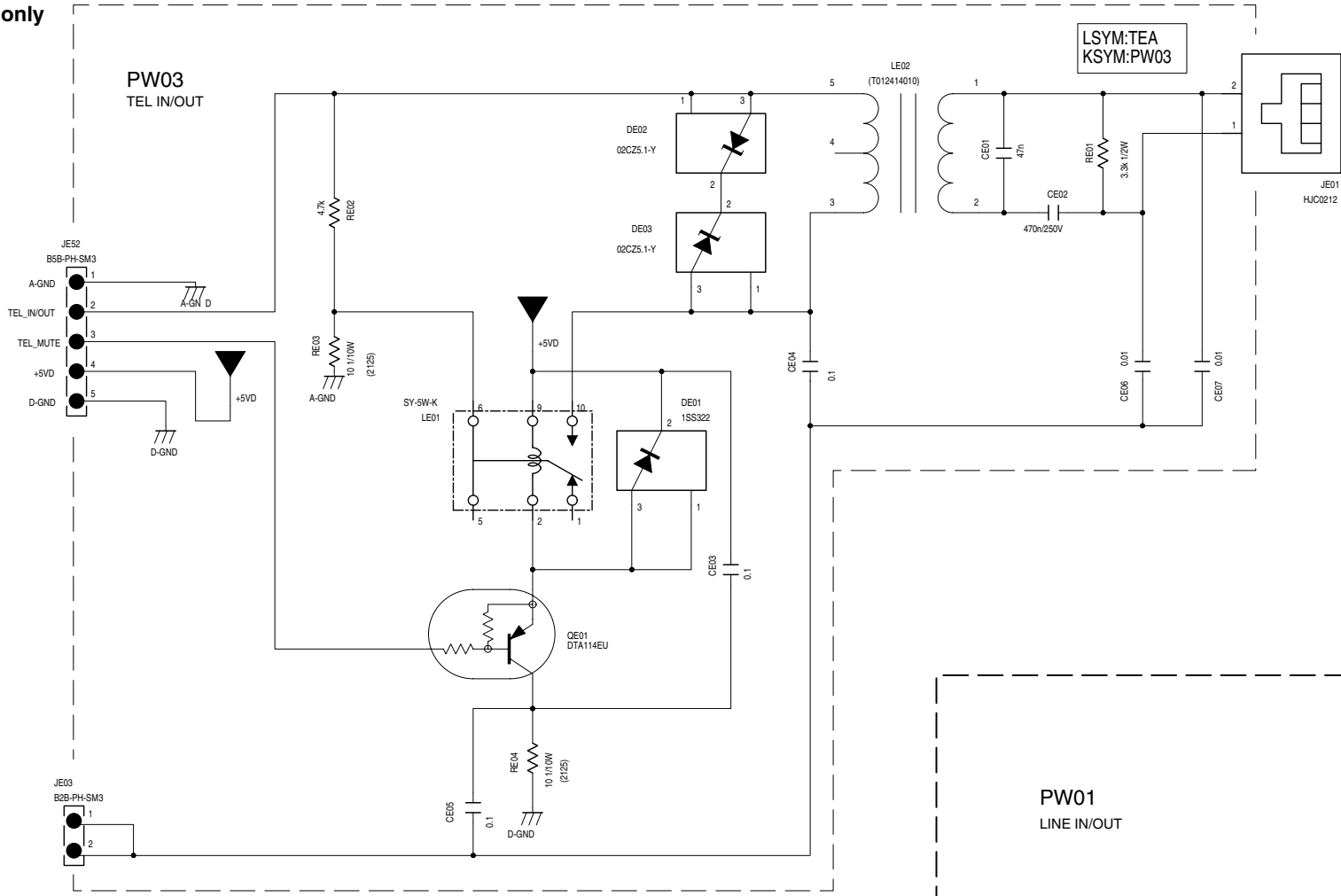

LSYM:TEA
KSYM:PW03

JE01
HJC0212

TO
TOP PCB
(TO JA33)

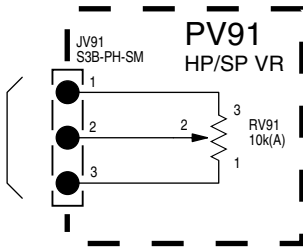

PW04
REC VR

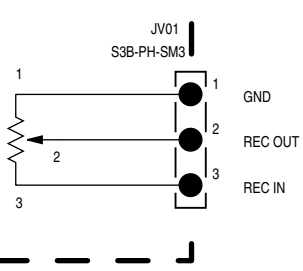

TO TOP PCB
(TO JK01)

PW01
LINE IN/OUT

OUT
LINE
IN

3
1
4
2
5

EARTH

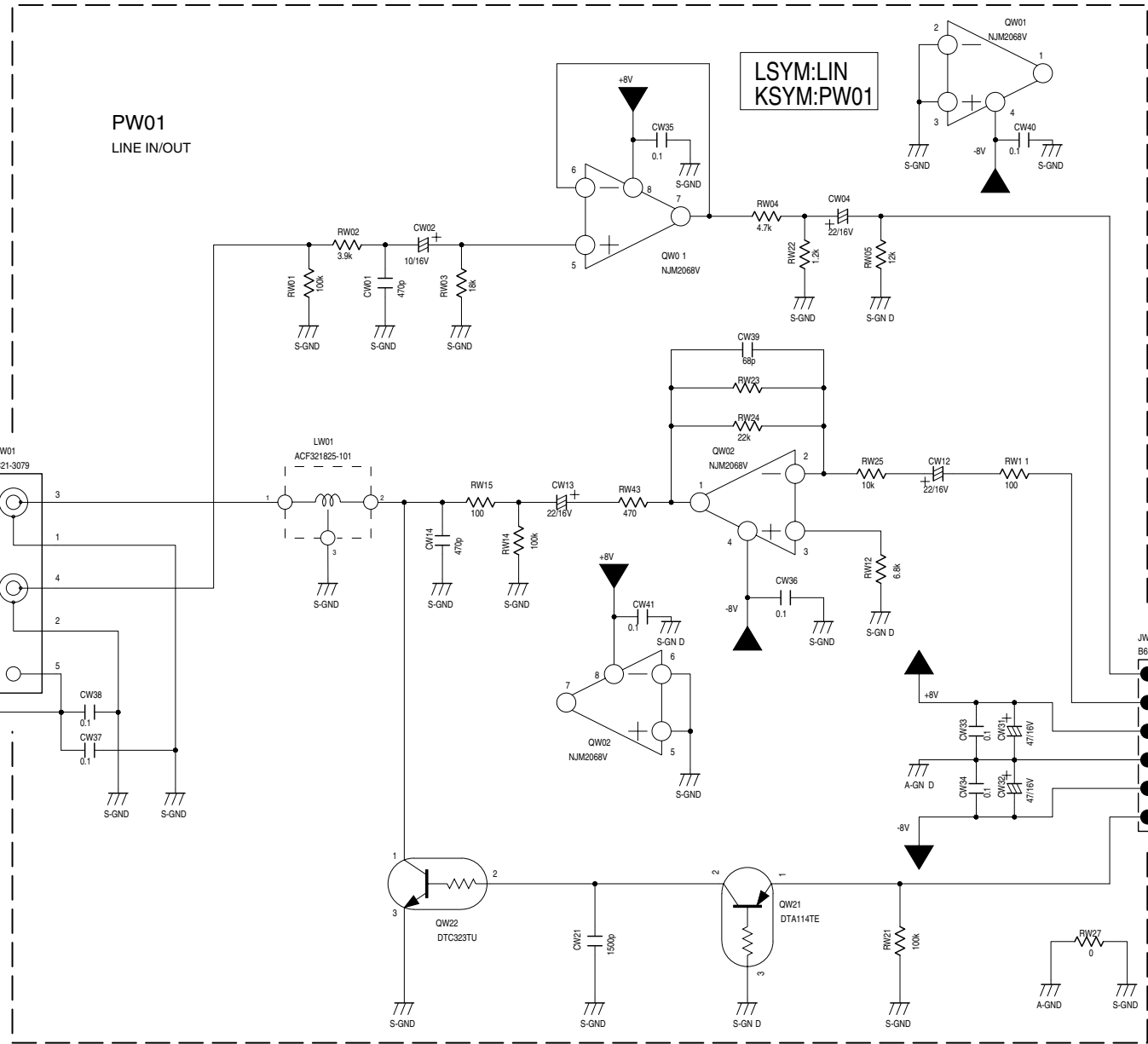

LSYM:LIN
KSYM:PW01

TO TOP PCB
(TO JK02)

1
2
3
4
5
6

LINE IN
LINE OUT
+8V
A-GND
-8V
MUTE

PMD690 only

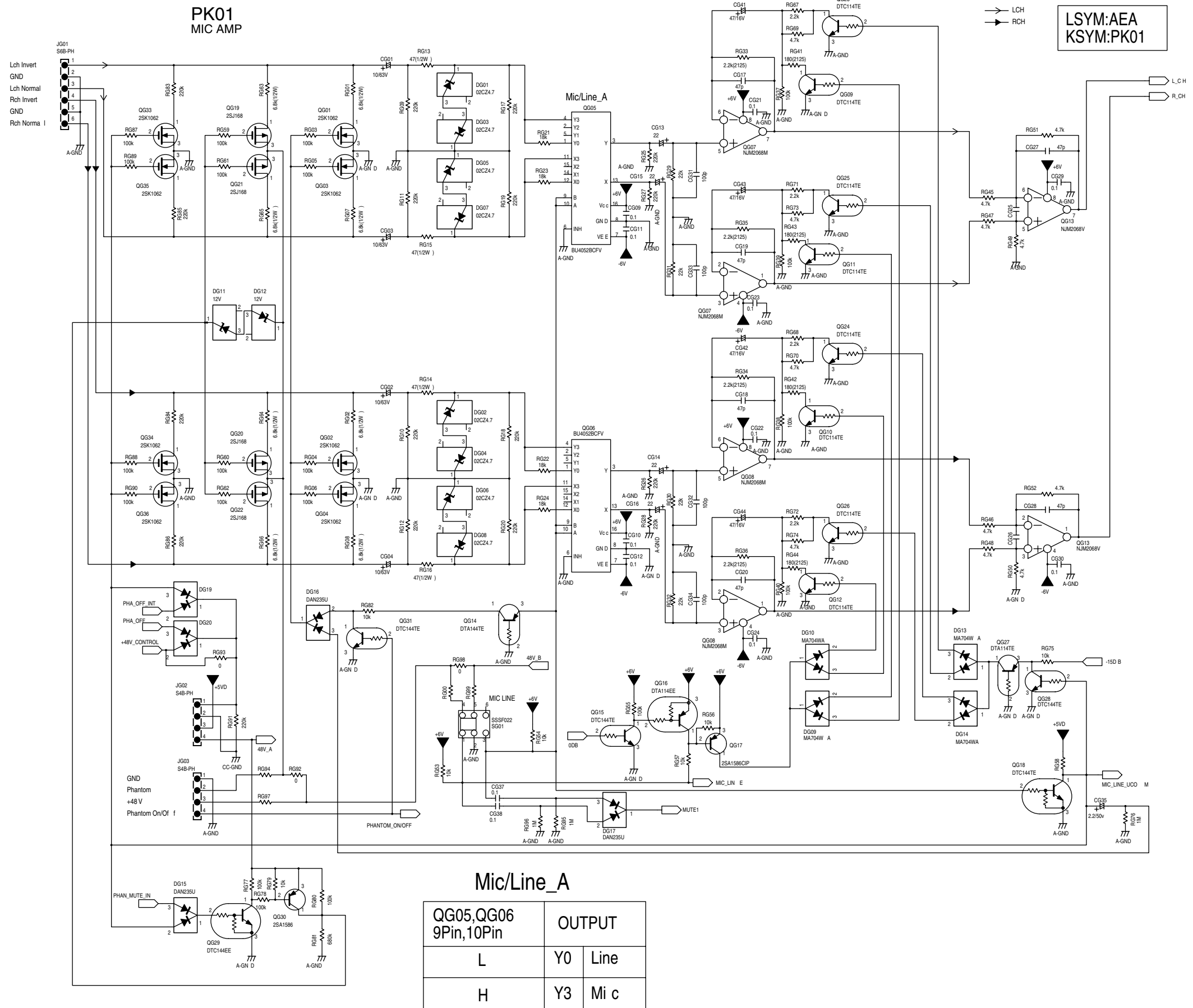

Mic/Line_A

QG05, QG06 9Pin, 10Pin		OUTPUT	
L	Y0	Line	
H	Y3	Mic	

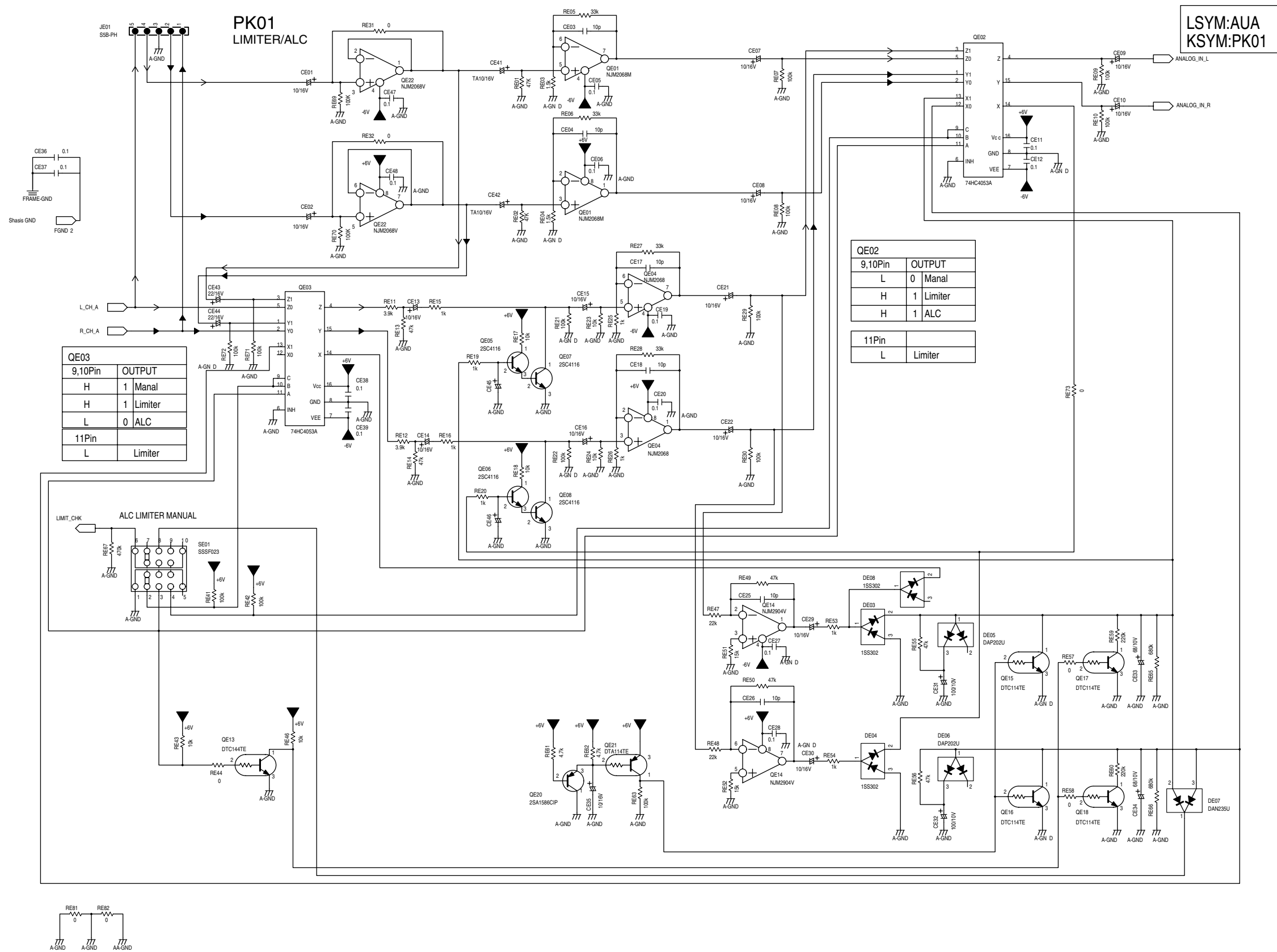

LSYM:AFA
KSYM:PK01

PK01
OUTPUT

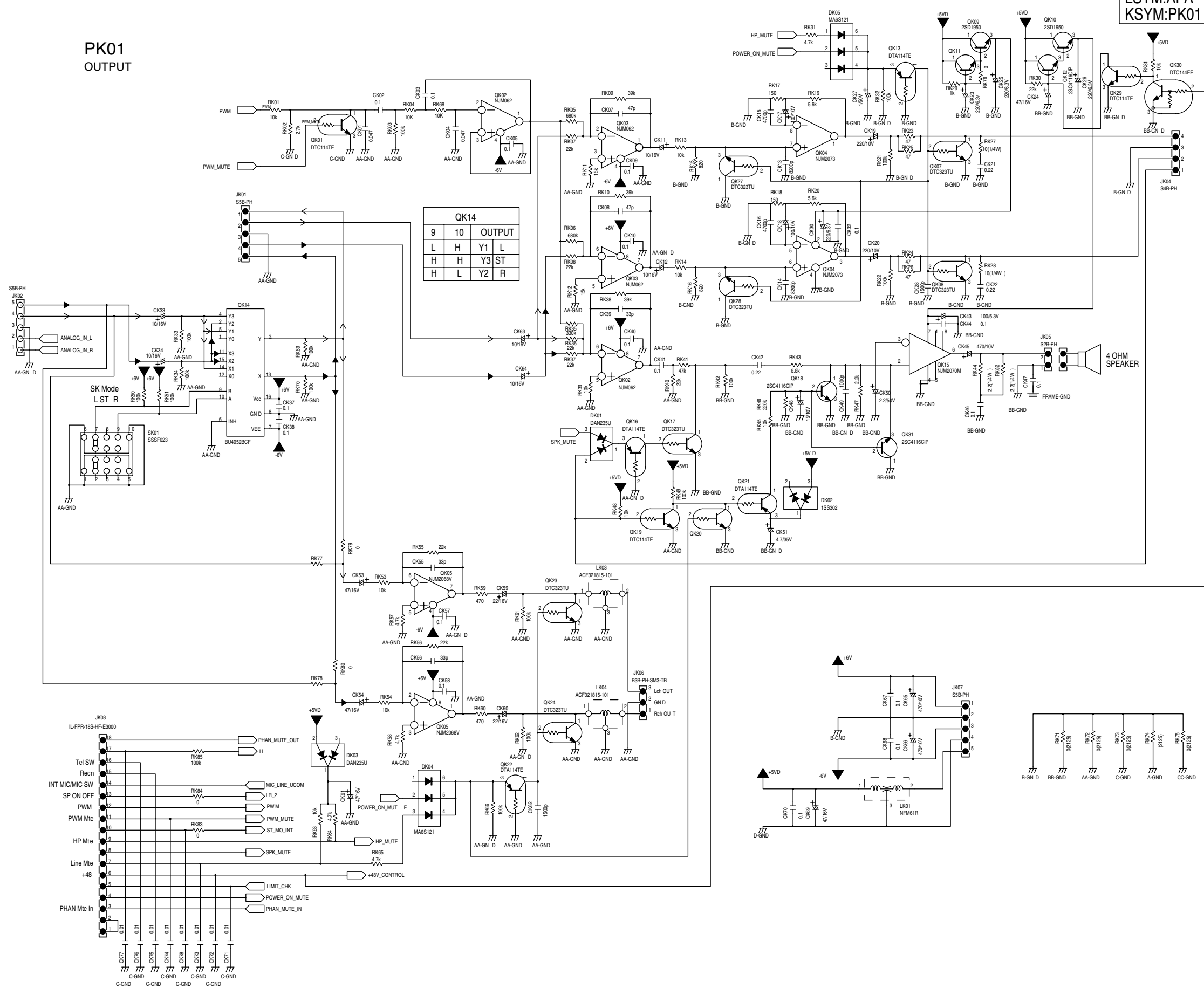

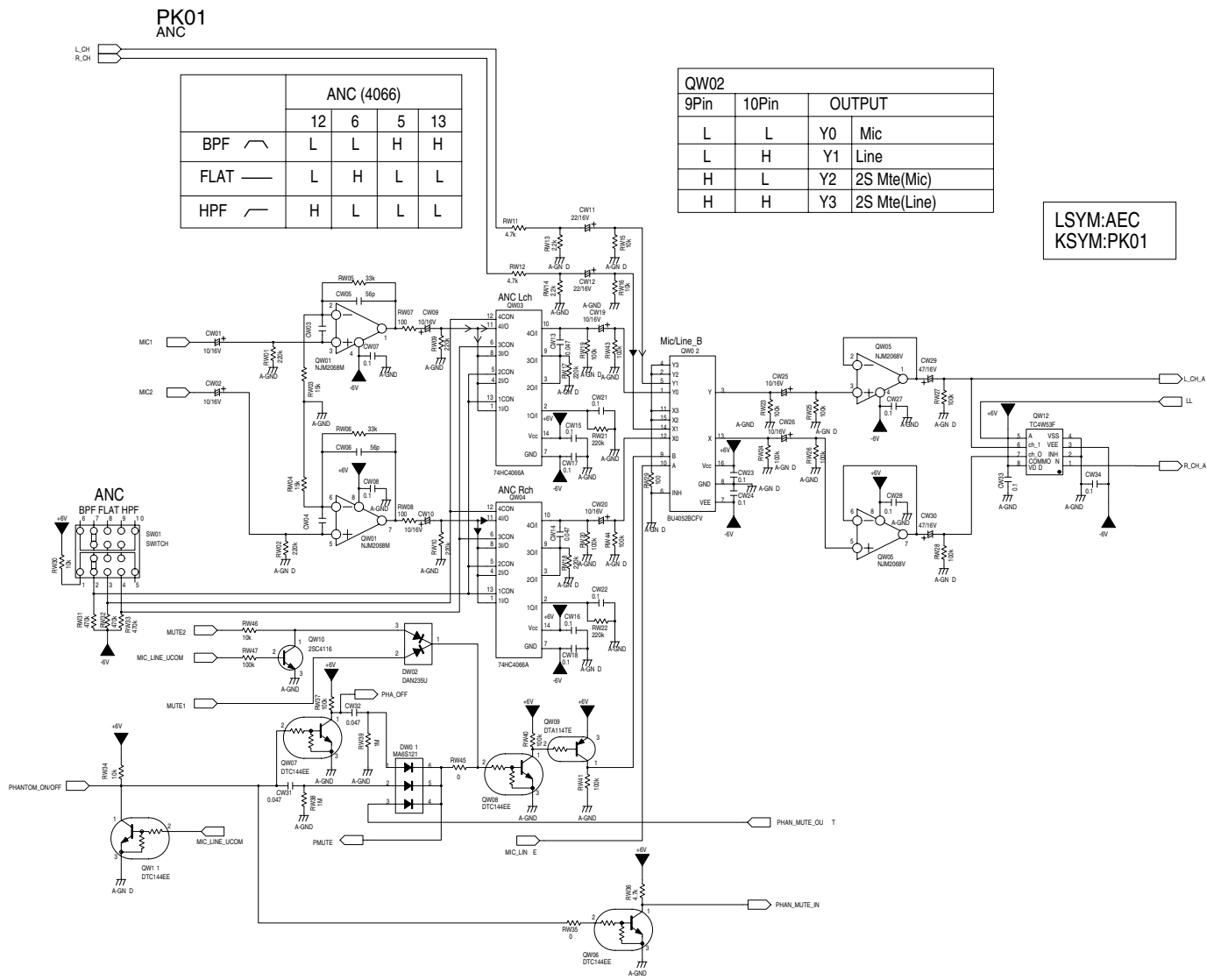
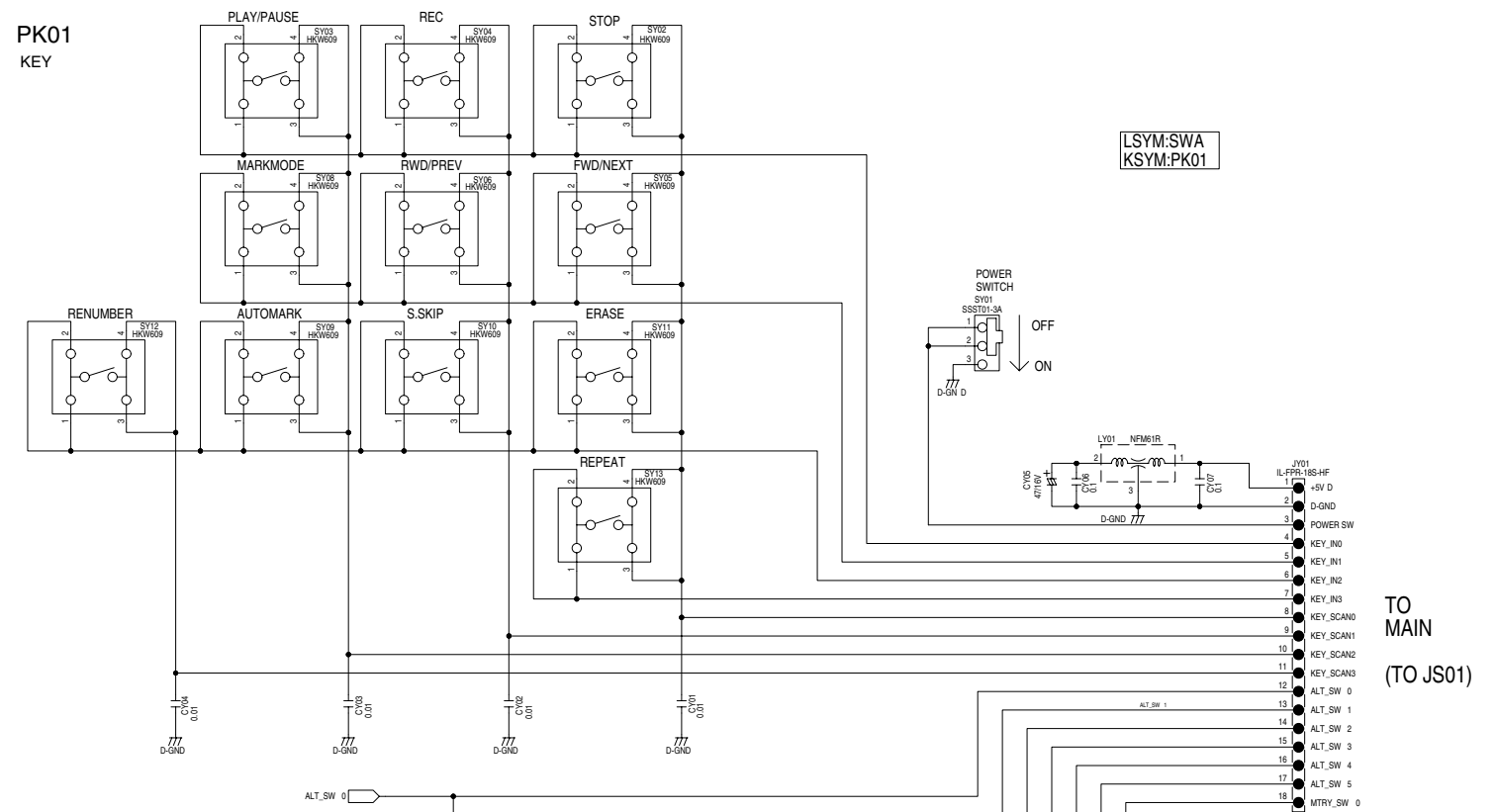

LSYM:AEB
KSYM:PK01

PK01
INT., ATT.

Mic Source SEL (Q405)

9Pin	10Pin	Output
H	H	Y3 Stereo
H	L	Y2 Mono
L	H	Y1 Int,2S MUTE
L	L	$\frac{L+R}{2}$

Mic ATT (Q406)

9Pin	10Pin	Output
L	H	Y1 0dB
H	L	Y2 -15dB
H	H	Y3 -30dB
L	L	Int

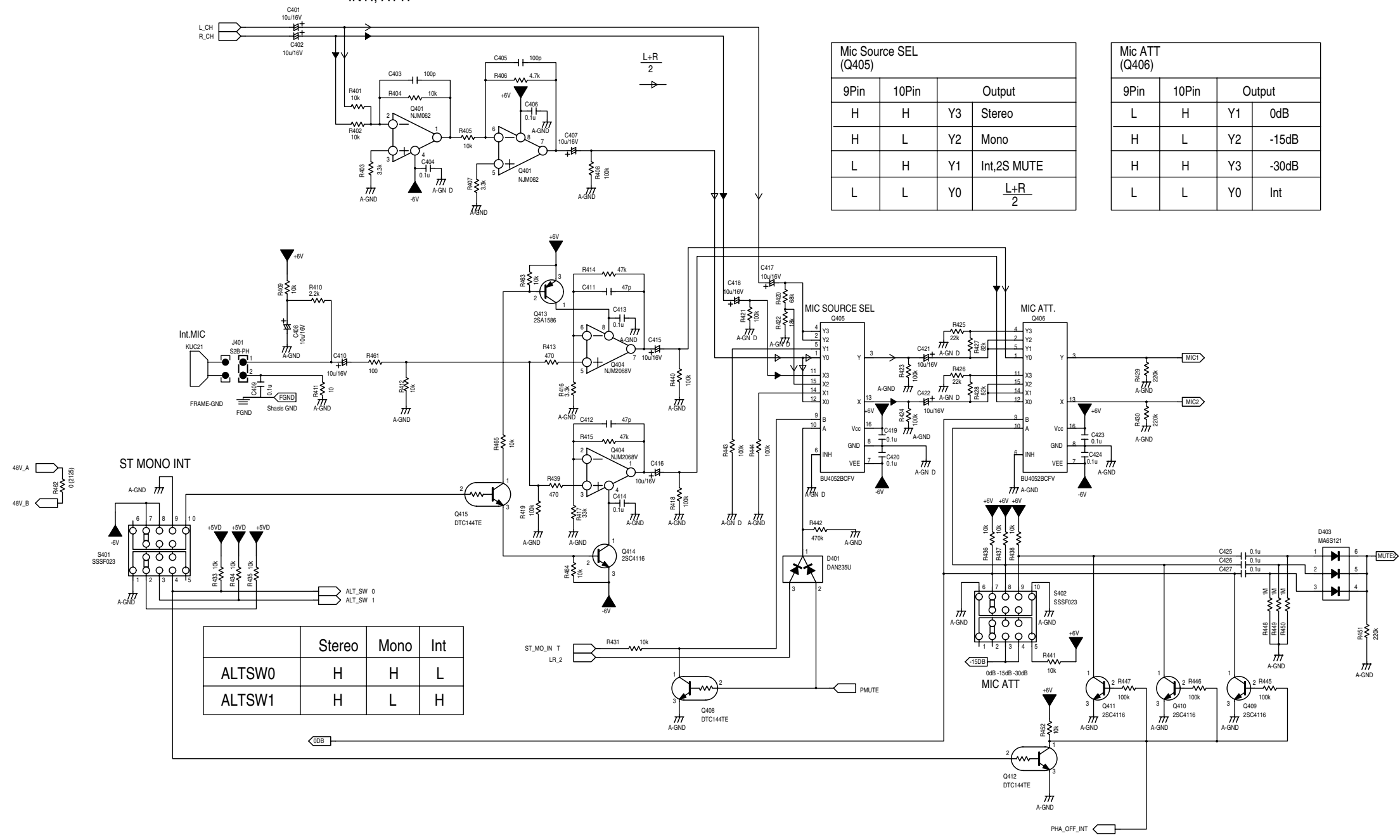

	Stereo	Mono	Int
ALTSW0	H	H	L
ALTSW1	H	L	H

PMD690 only

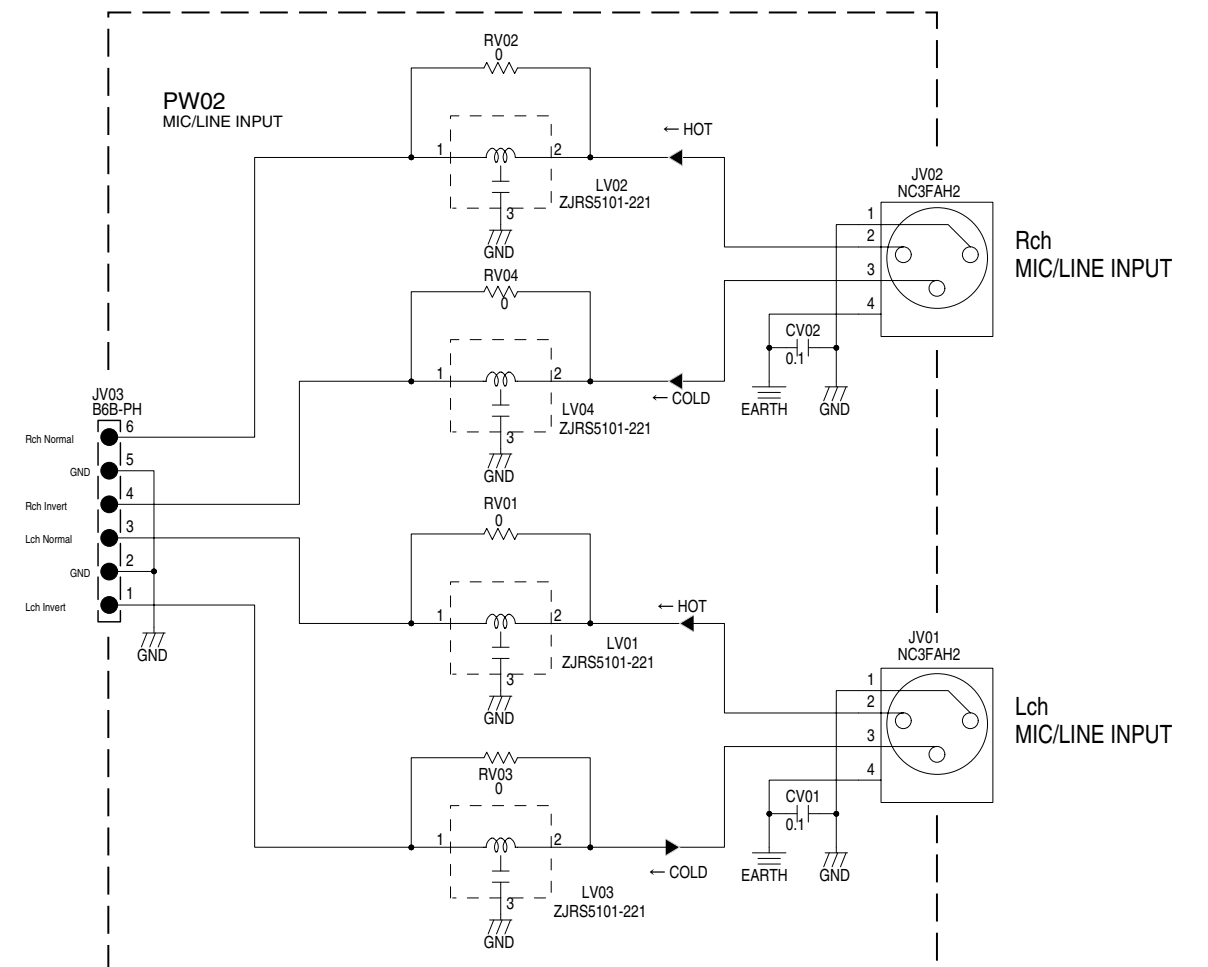
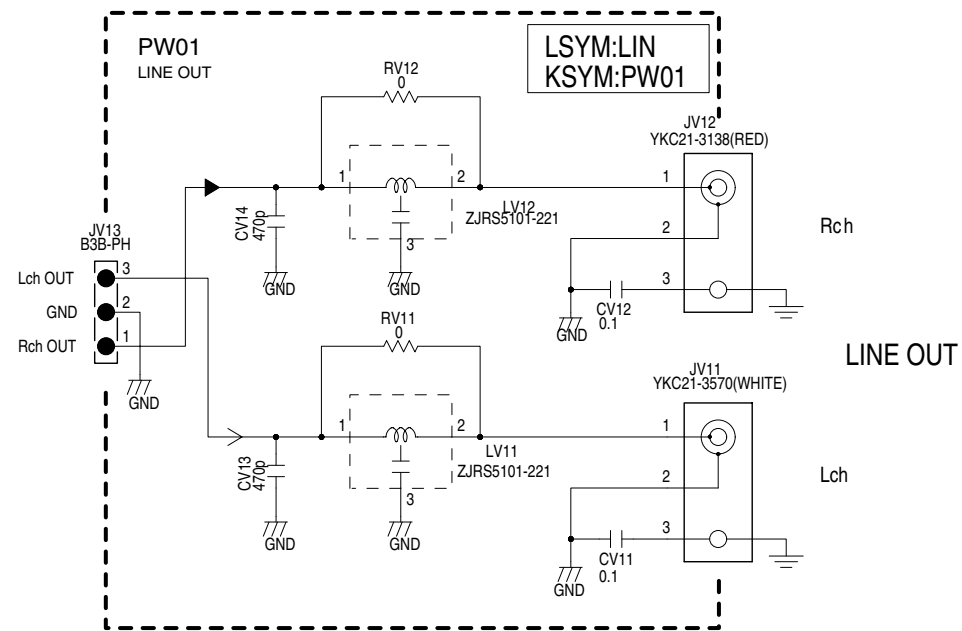
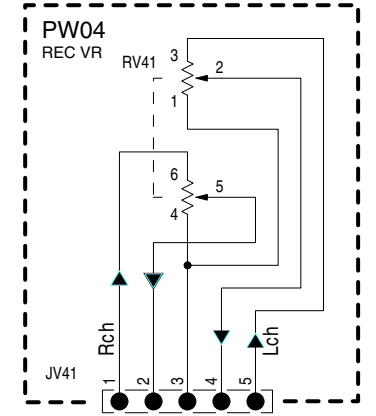
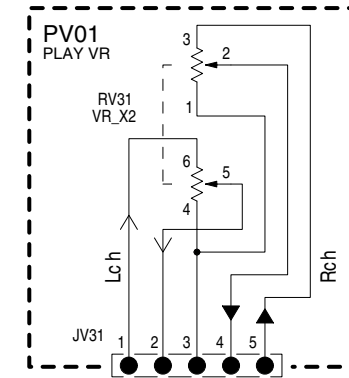
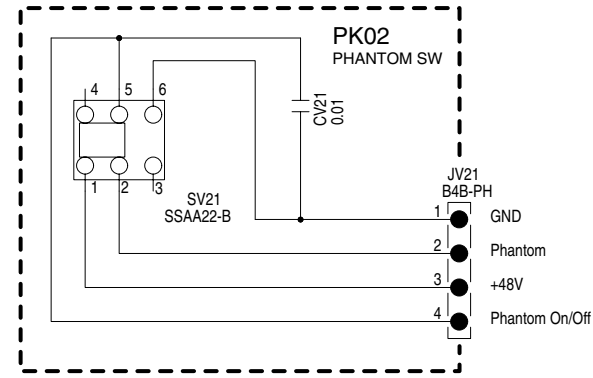
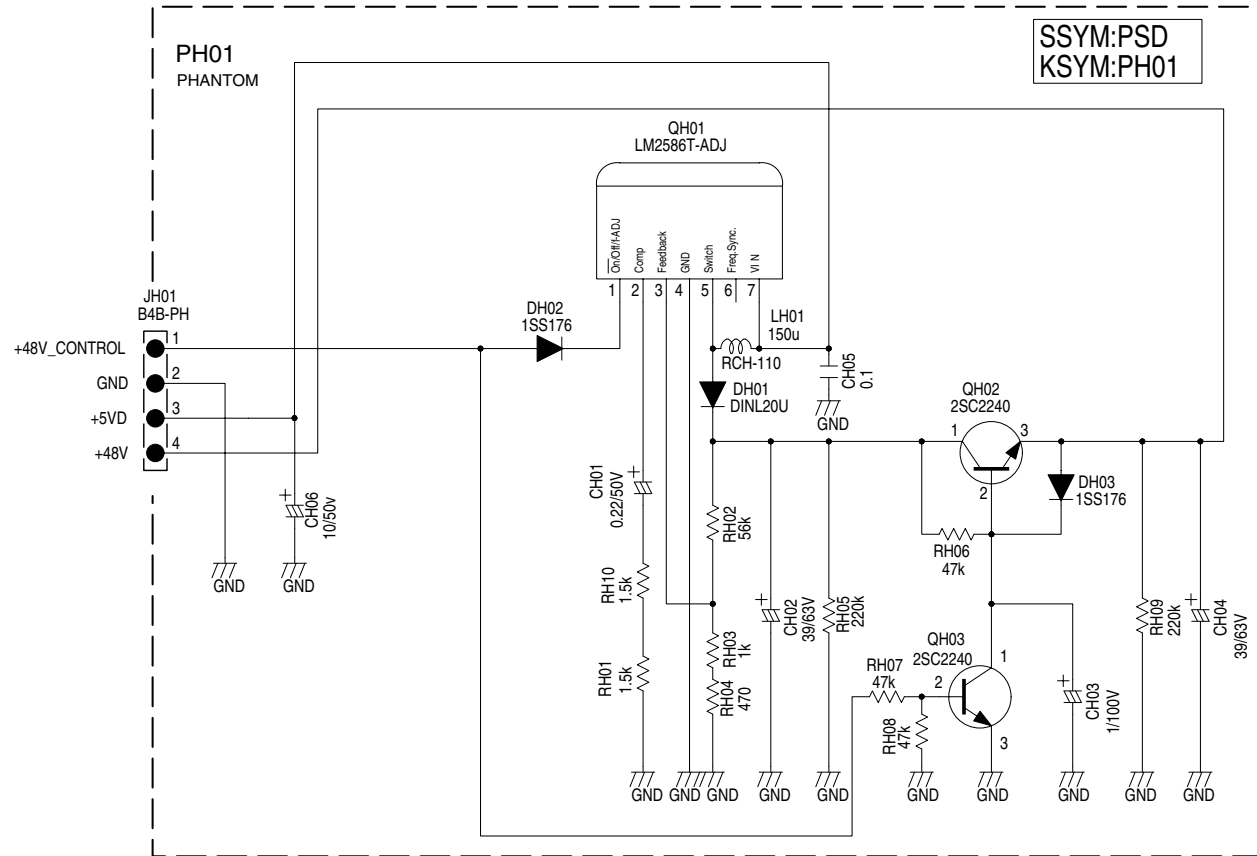

5. PARTS LOCATION

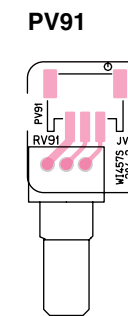
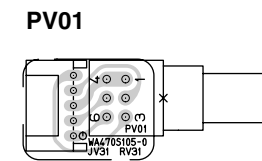
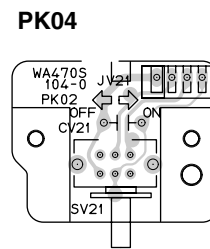
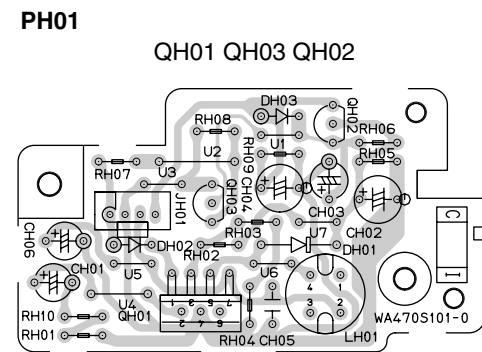
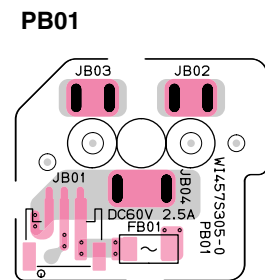
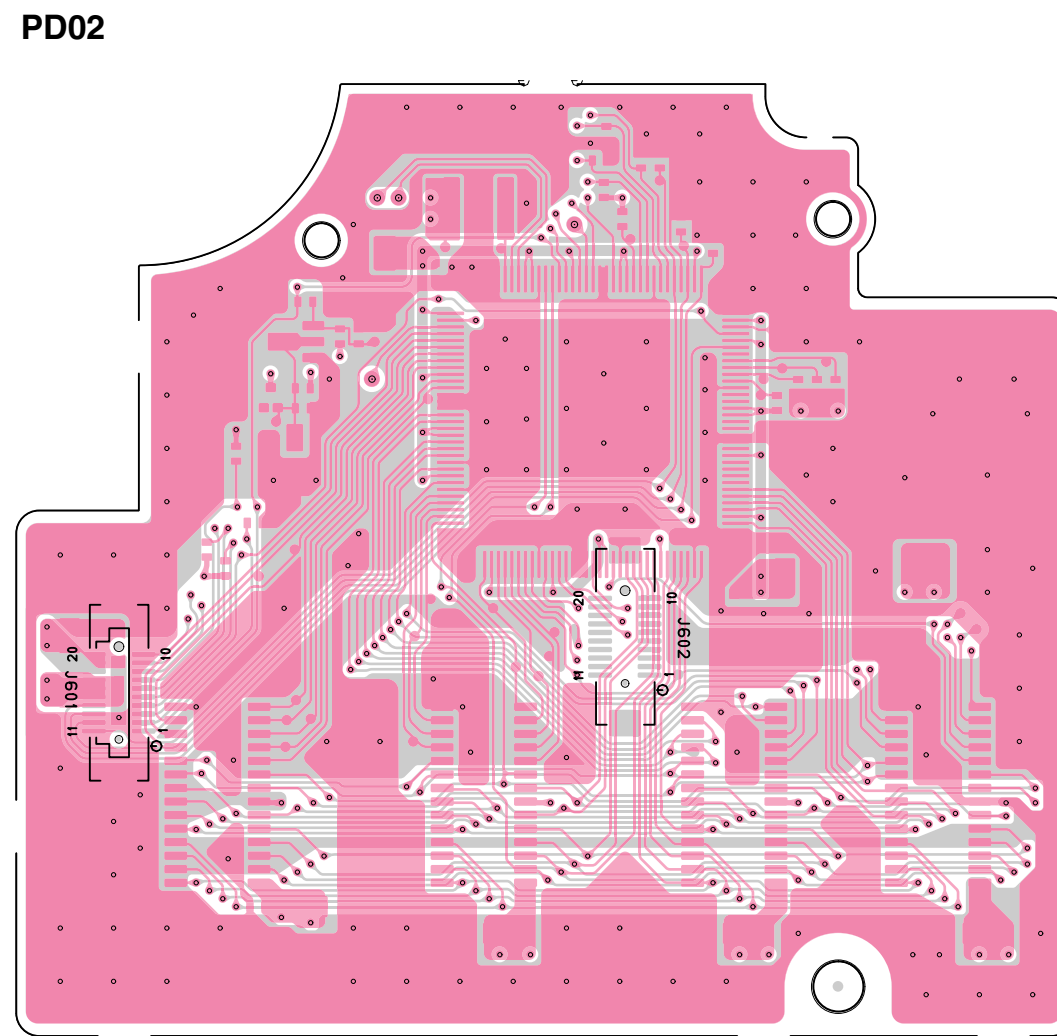
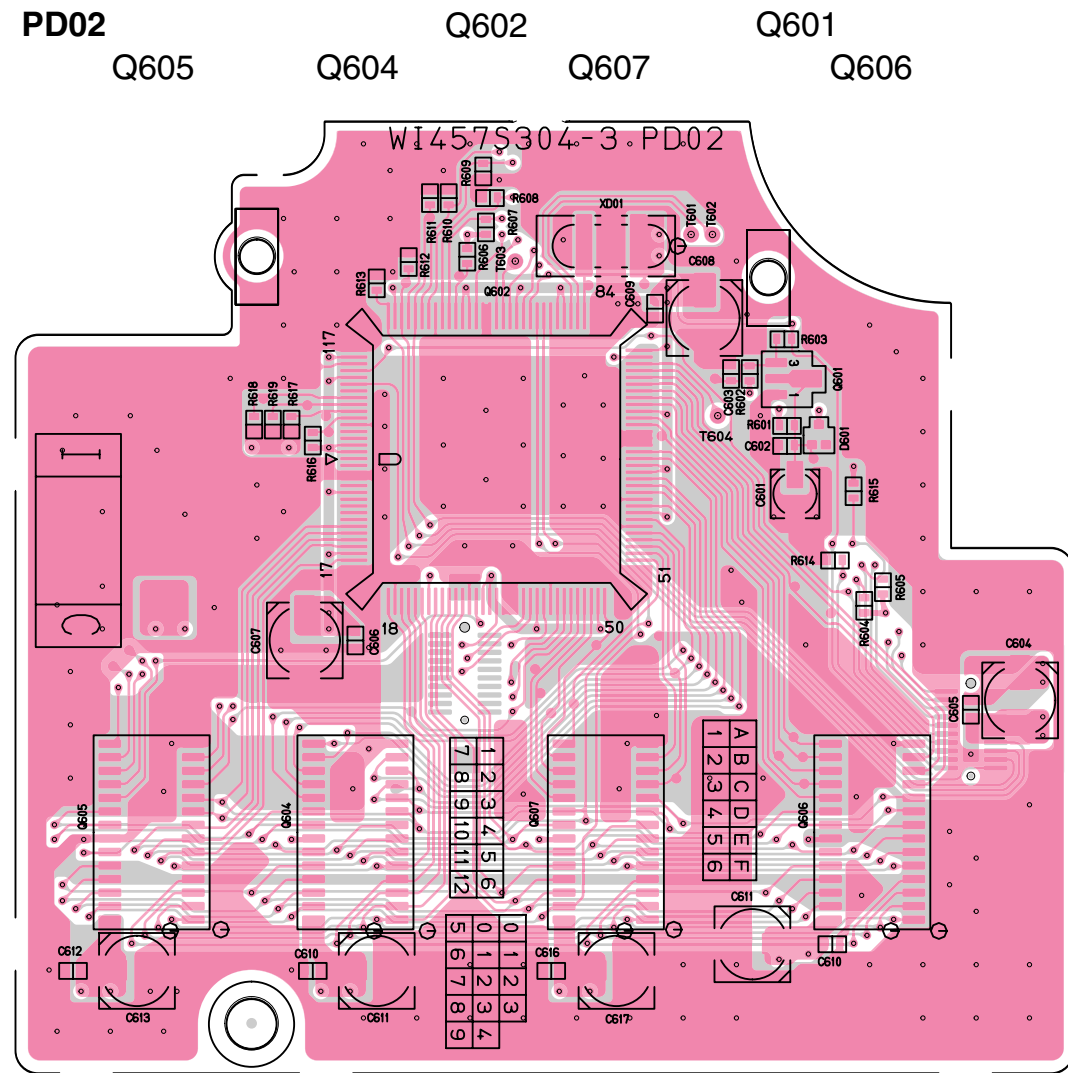

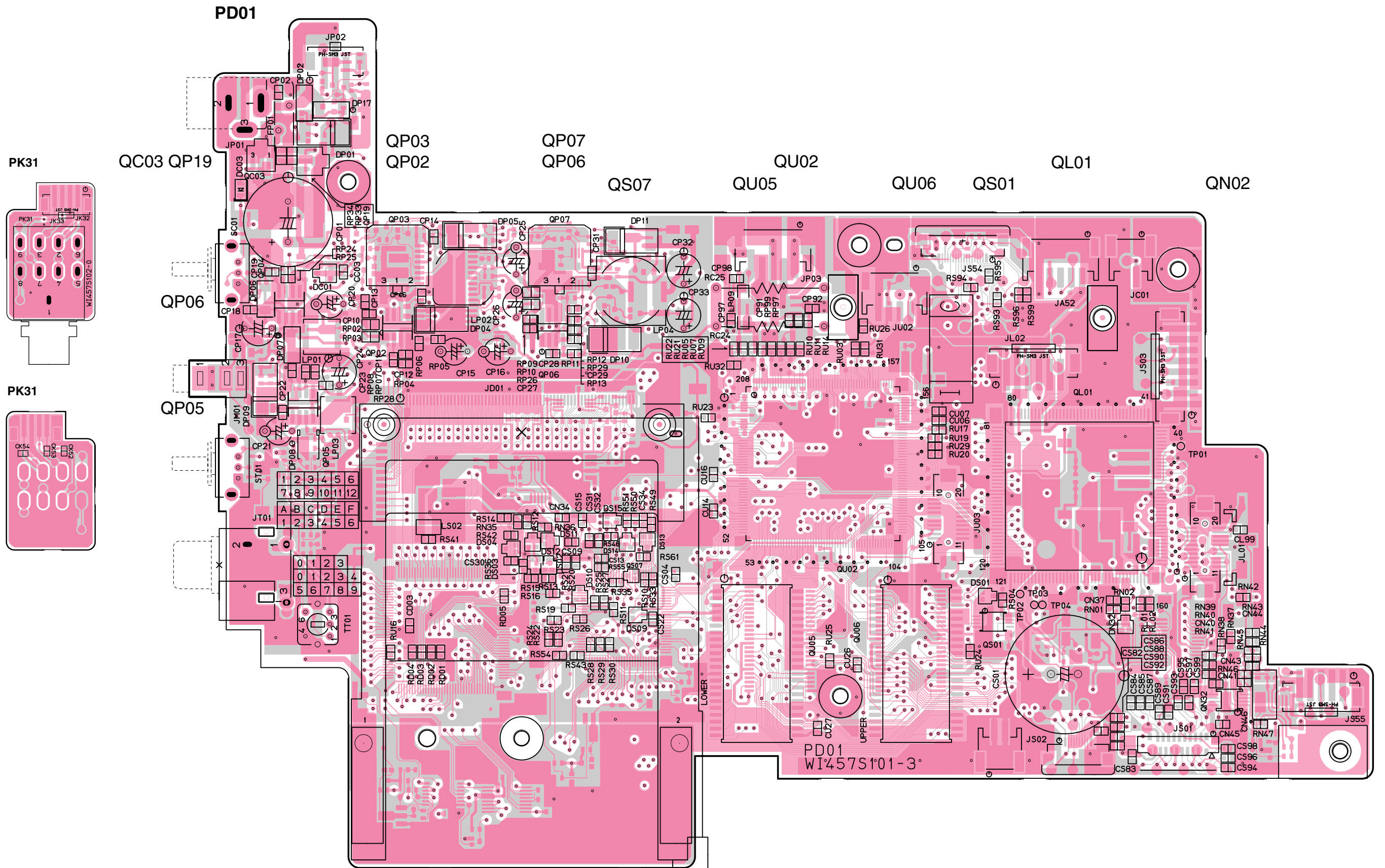

PD01

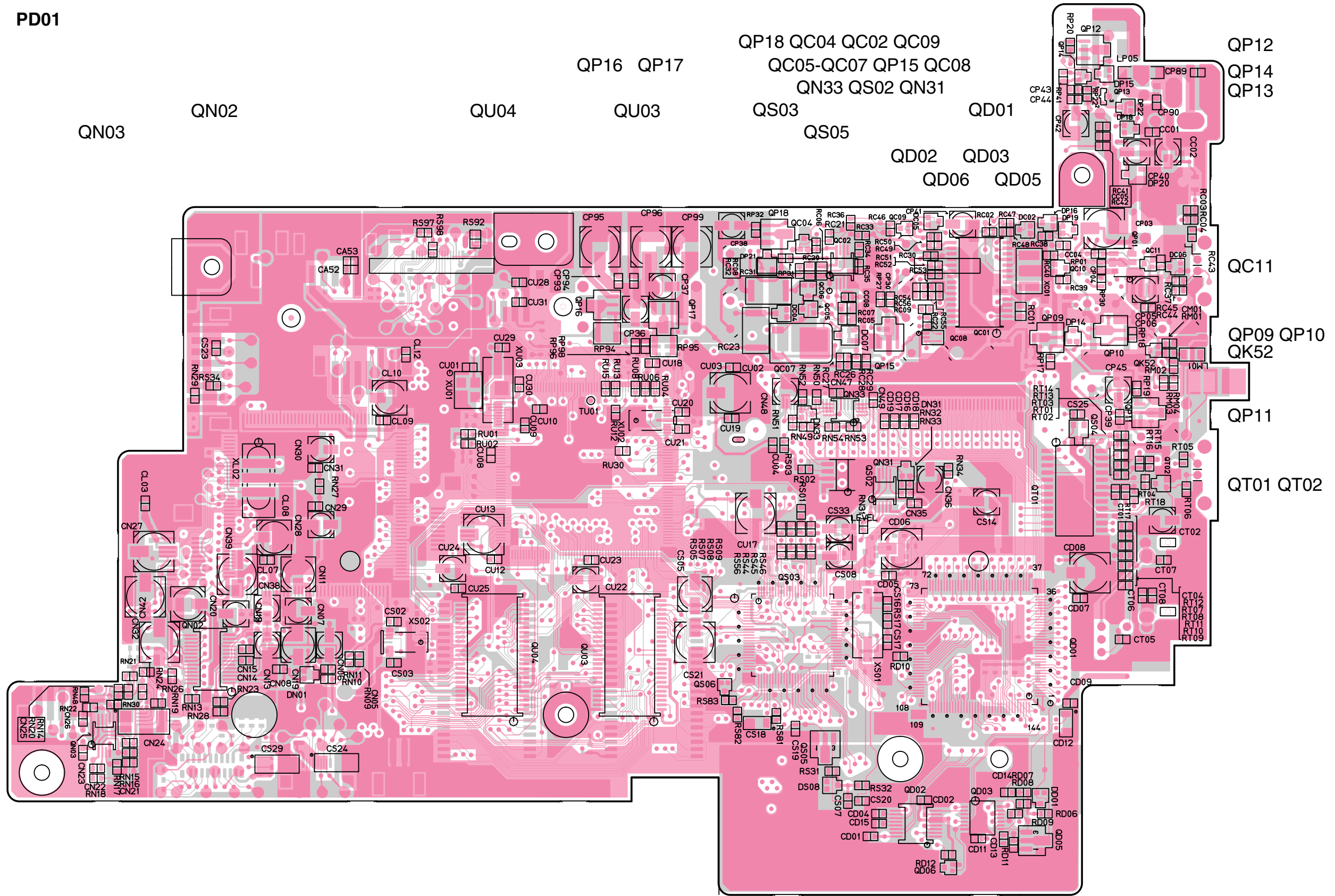

PK01
(PMD680 Only)

QA06 QA22
QK16 QK15

QA99 QA98
QA15-QA13

QK09 QK17 QK10 QK11

QA17-QA19

QA07
QA04 QA25
QK05

QA23 QA24
QA01 QA20 QA81 QA82
QK06 QK07

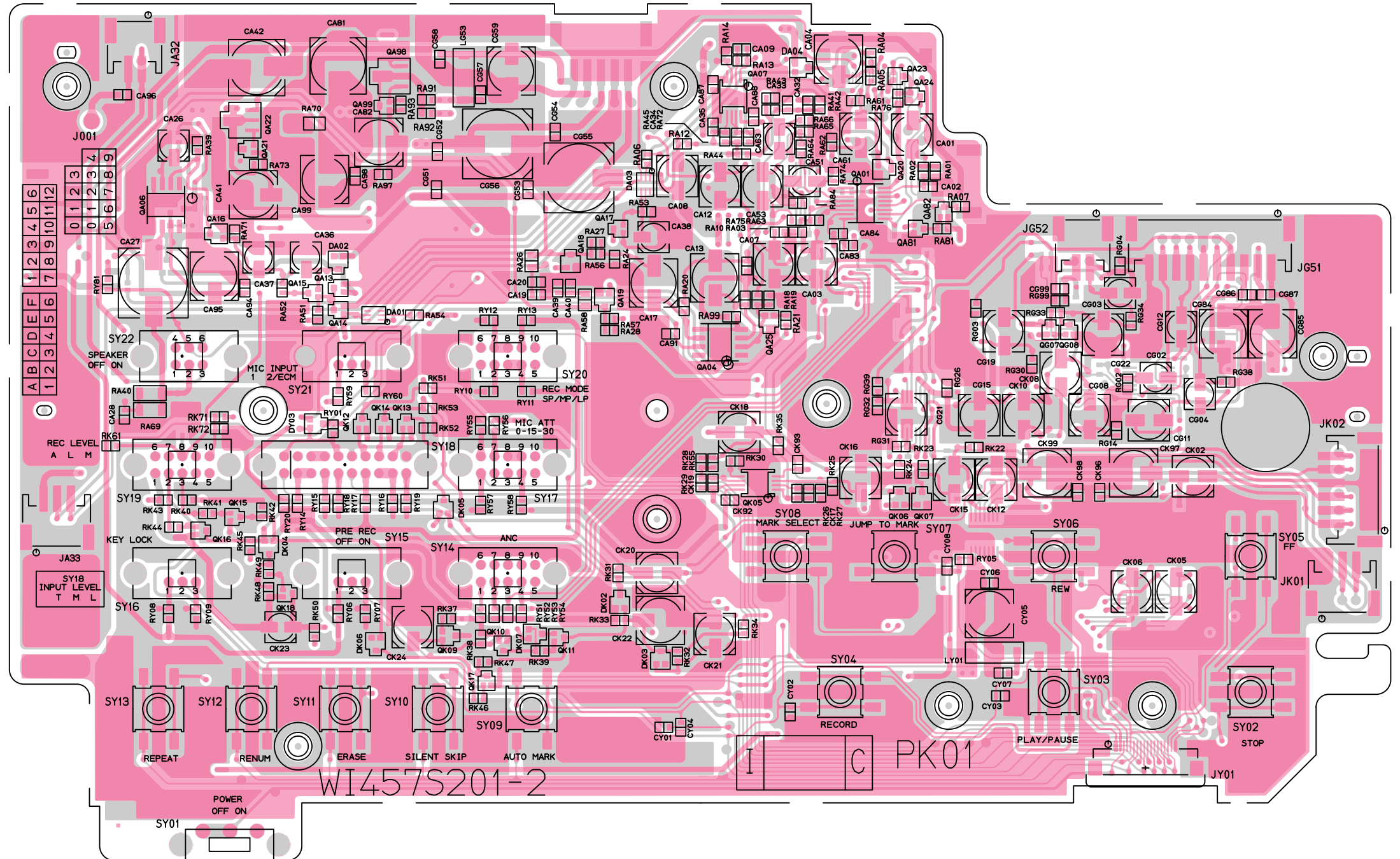

PK01 (PMD680 Only)

QA83

QA11

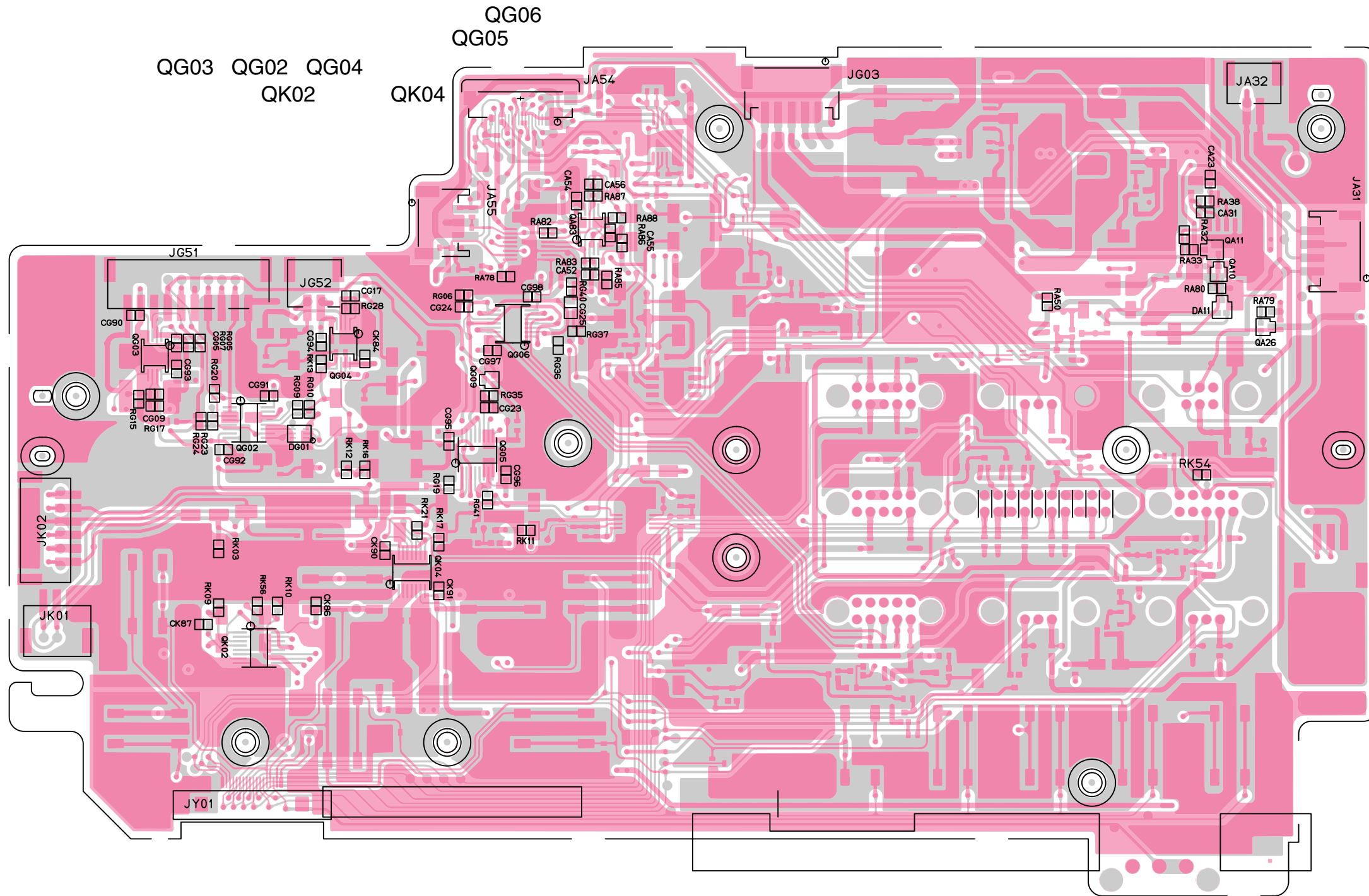

PK01 (PMD690 Only)

QK18 QW01 Q405 Q406 QG07 QG05 QG03 QK01 QG05
 QK04 QK03 QK02 QW04 QW03 Q401 QG13
 QW02 QG08 QG06 QG02 QG04
 QM12 Q415 Q414 Q404 QE20 QE21 QE15 QE16

QG33 QG35 QG36 QE08 QE06
 QE09 QE02 QE07 QE05

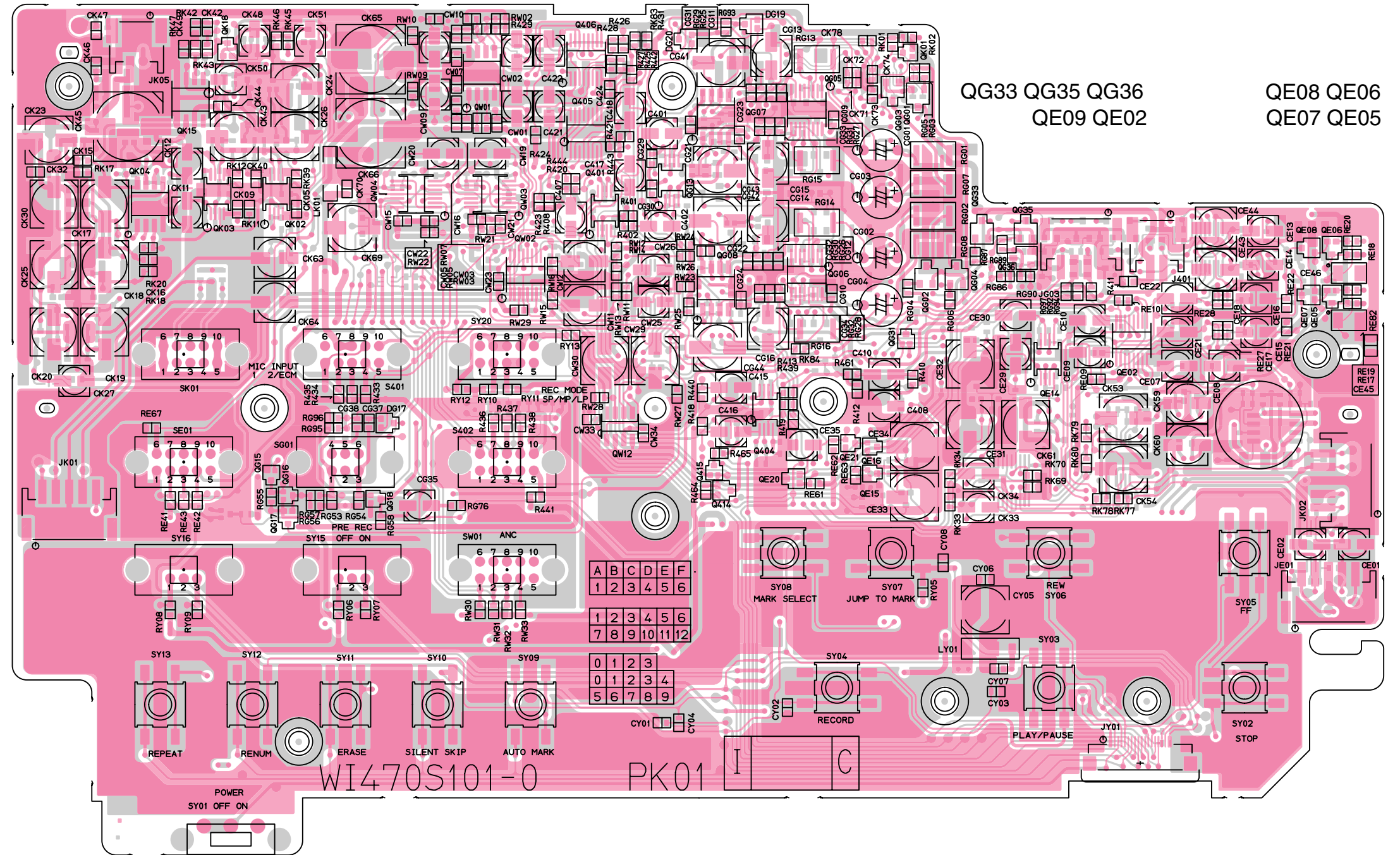

PK01 (PMD690 Only)

QG09 QG11 QG25 QG23
QG14 QG12 QG26 QW05 QW09-QW06
QG28 QG27 Q413 Q408 Q411-Q409
QE17 QE18

QK19 QK20 QK31
QK10 QK30 QK17 QK16
QW10 QK07 QK08
QK13

QE04 QE03 QG19-QG20
QG30 QG34 QG29
QE22 QE01 QK24-QK22 QK05 QK14

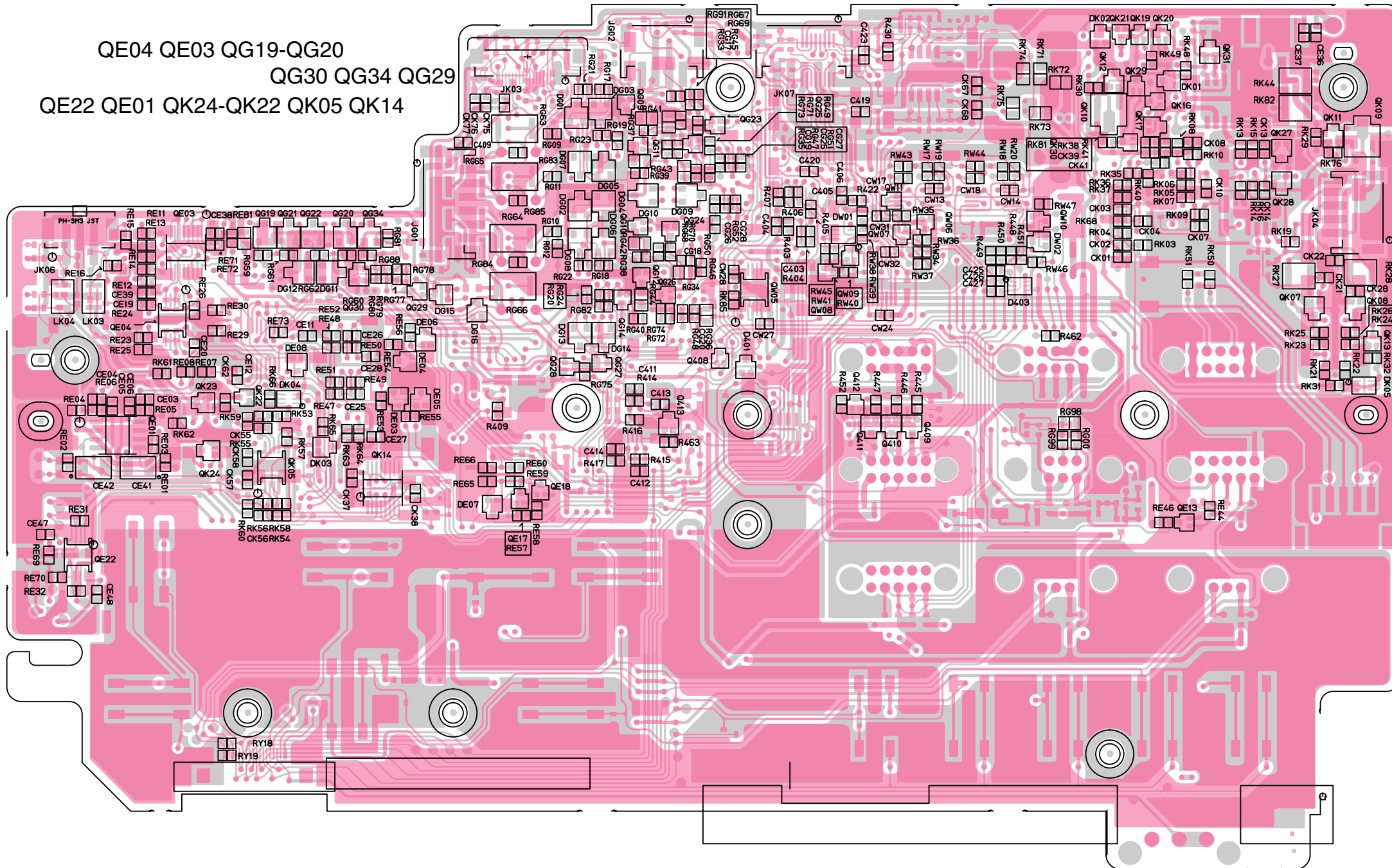

PF01

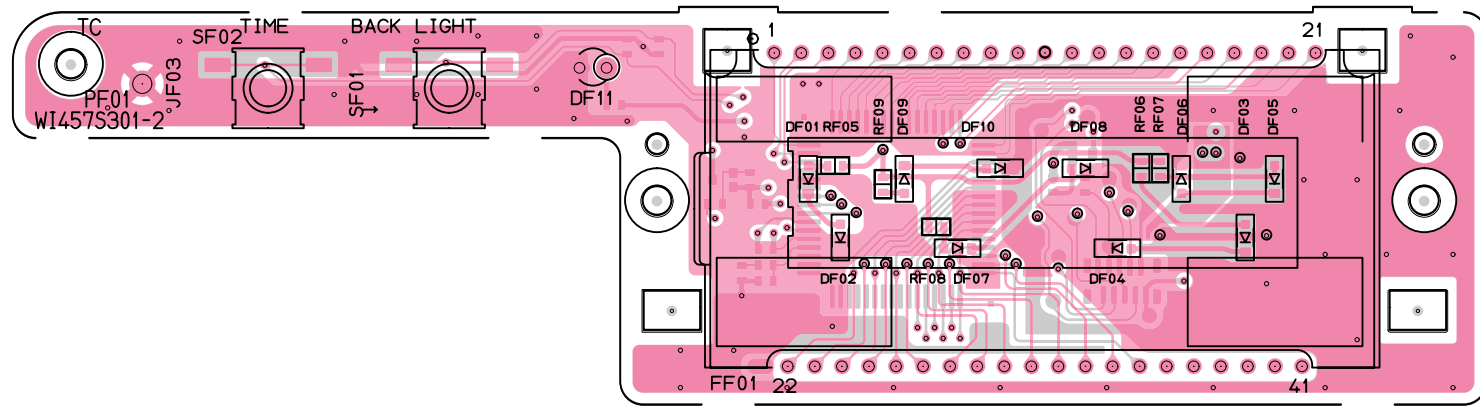

PW03

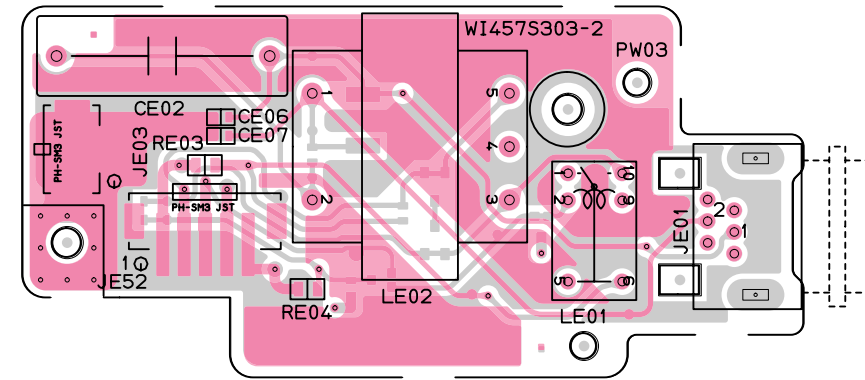

PF01

QF03

QF01

QF02

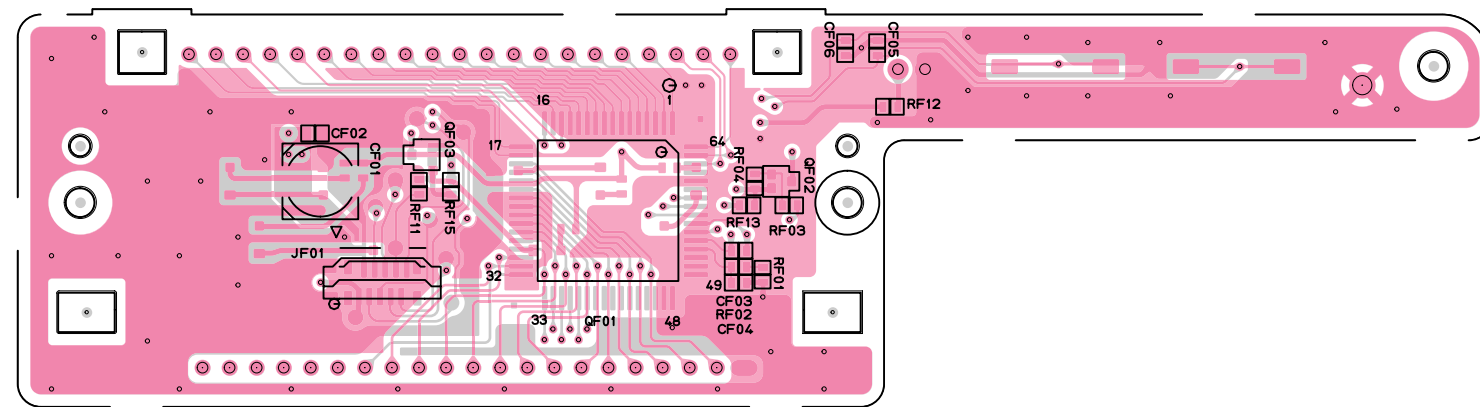

PW03

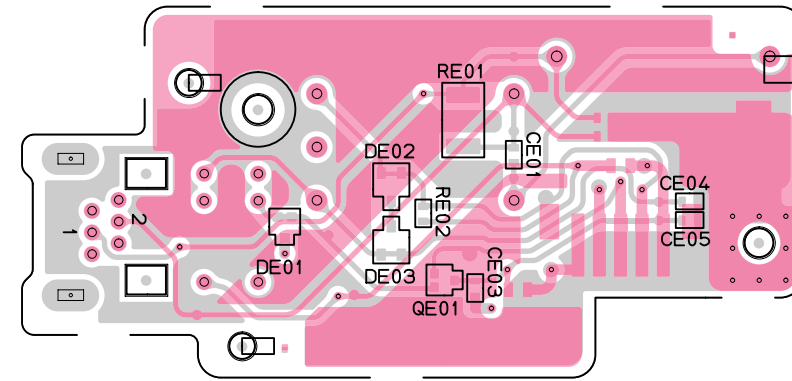

PW01

PW01

QW02 QW01

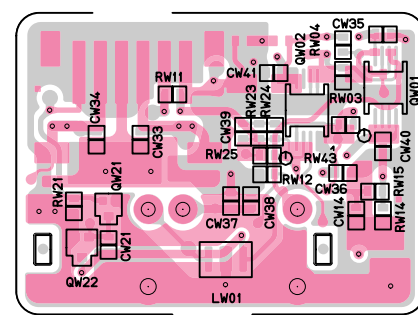
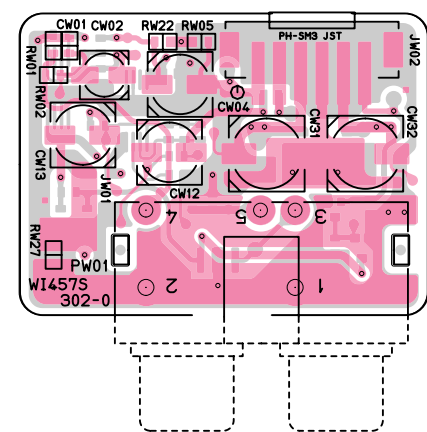

PMD690 Only

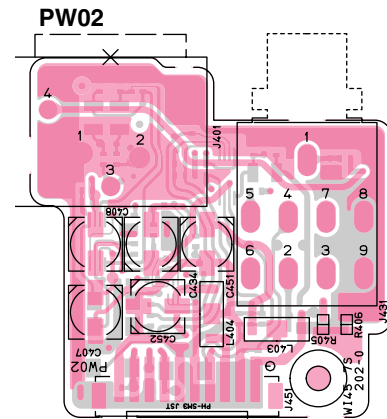

PW02 Q403 Q432 Q401 Q404 Q431 Q431

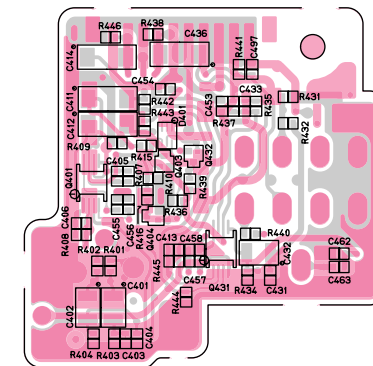

PMD680 Only

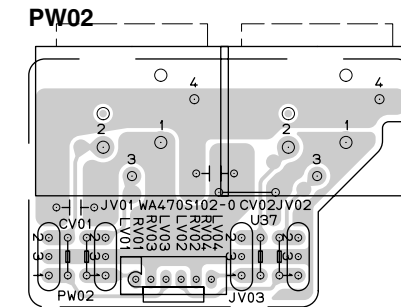

PW041

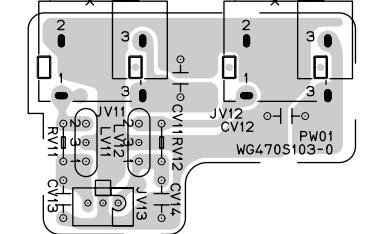

PMD690 Only

PW04

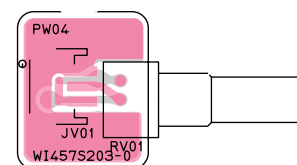

PMD680 Only

PW04

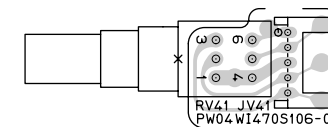

6. MICROPROCESSOR AND IC DATA

QN02:PCM3000

BLOCK DIAGRAM

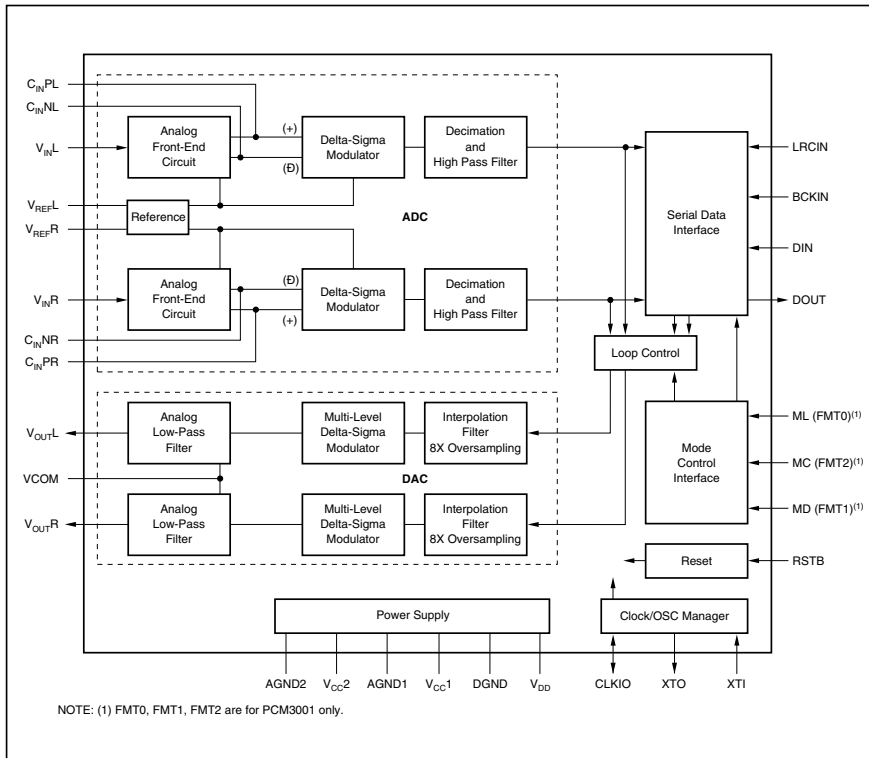

PIN ASSIGNMENTS PCM3000/3001

PIN	NAME	I/O	DESCRIPTION
1	V_{INL}	IN	ADC Analog Input, Lch
2	V_{CC1}	-	ADC Analog Power Supply
3	AGND1	-	ADC Analog Ground
4	V_{REFL}	-	ADC Input Reference, Lch
5	V_{REFR}	-	ADC Input Reference, Rch
6	V_{INR}	IN	ADC Analog Input, Rch
7	C_{INPR}	-	ADC Anti-alias Filter Capacitor (+), Rch
8	C_{INNR}	-	ADC Anti-alias Filter Capacitor (⊖), Rch
9	C_{INNL}	-	ADC Anti-alias Filter Capacitor (⊖), Lch
10	C_{INPL}	-	ADC Anti-alias Filter Capacitor (+), Lch
11	VCOM	-	DAC Output Common
12	V_{OUTR}	OUT	DAC Analog Output, Rch
13	AGND2	-	DAC Analog Ground
14	V_{CC2}	-	DAC Analog Power Supply
15	V_{OUTL}	OUT	DAC Analog Output, Lch
16	LRCIN	IN	Sample Rate Clock Input (f_s) ⁽²⁾
17	BCKIN	IN	Bit Clock Input ⁽²⁾
18	DIN	IN	Data Input ⁽²⁾
19	DOUT	OUT	Data Output
20	XTI	IN	Oscillator Input
21	XTO	OUT	Oscillator Output
22	CLKIO	I/O	Buffered Output of Oscillator or External Clock Input ⁽²⁾
23	V_{DD}	-	Digital Power Supply
24	DGND	-	Digital Ground
25	MC/FMT2	IN	Serial Control Bit Clock (PCM3000)/Data Format Control 2 (PCM3001) ^{(1), (2)}
26	MD/FMT1	IN	Serial Control Data (PCM3000)/Data Format Control 1 (PCM3001) ^{(1), (2)}
27	ML/FMT0	IN	Serial Control Strobe Pulse/Data Format Control 0 (PCM3001) ^{(1), (2)}
28	RSTB	IN	Reset ^{(1), (2)}

NOTES: (1) With 70kΩ typical internal pull-up resistor. (2) Schmitt trigger input.

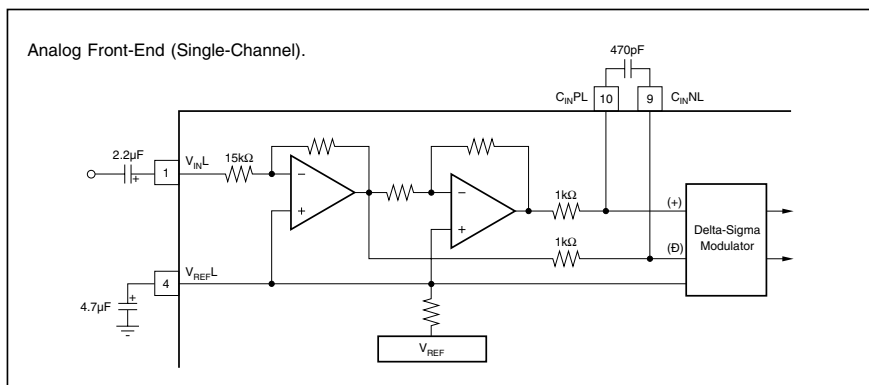

QS03:H8-3048 (PMD680 Only)

No	Port name	I/O	USE	Sig. Name	ACT	INI	RST	STB	Description
1	VCC	I	-	-					+5V
2	TIOCA3	I/O	O	PWM	-	L	Z	K	Buzzer
3	PB1	I/O	O	TEL_SW	H	L	Z	K	
4	PB2	I/O	O	REC_N	H	L	Z	K	
5	PB3	I/O	O	ML	H	L	Z	K	for CODEC
6	PB4	I/O	O	MC	H	L	Z	K	for CODEC
7	PB5	I/O	O	MD	H	L	Z	K	for CODEC
8	PB6	I/O	I/O	I ² C Bus SDA	L	H	Z	K	Pull Up 22 kohm
9	PB7	I/O	O	I ² C Bus SCL	L	H	Z	K	Pull Up 22 kohm
10	VPP	I	-	for Flash Writing					+12V
11	VSS	I	-	-					Ground
12	TXD0	O	O	to LCD driver				Z	K
13	TXD1	O	O	to Main MPU (RXD1)				Z	K
14	RXD0	I	I	NC				Z	K
15	RXD1	I	I	from Main MPU (TXD1)				Z	K
16	P94	I/O	O	LCD_R/W	L	H	Z	K	
17	SCK0	I/O	O	to LCD driver				Z	K
18	P40	I/O	I	KEY IN 0	L	Z	Z	K	CMOS Pull Up
19	P41	I/O	I	KEY IN 1	L	Z	Z	K	CMOS Pull Up
20	P42	I/O	I	KEY IN 2	L	Z	Z	K	CMOS Pull Up
21	P43	I/O	I	KEY IN 3	L	Z	Z	K	CMOS Pull Up
22	VSS	I	-	-					Ground
23	P44	I/O	I	ALT_SW 8 [REC LEVEL]				Z	K
24	P45	I/O	I	ALT_SW 9 [REC LEVEL]				Z	K
25	P46	I/O	I	NC				Z	K
26	P47	I/O	I	NC				Z	K
27	P30	I/O	O	KEY SCAN 0	L	H	Z	K	
28	P31	I/O	O	KEY SCAN 1	L	H	Z	K	
29	P32	I/O	O	KEY SCAN 2	L	H	Z	K	
30	P33	I/O	O	KEY SCAN 3	L	H	Z	K	
31	P34	I/O	O	REC_LED (RED)	H	L	Z	K	
32	P35	I/O	O	EM0/_C9	L	H	Z	K	for DIT
33	P36	I/O	O	LCD BACK LIGHT	H	L	Z	K	
34	P37	I/O	O	LCD_INH	L	H	Z	K	
35	VCC	I	-	-					+5V
36	P10	I/O	O	DC/DC +5V SW	H	L	Z	K	
37	P11	I/O	O	DC/DC +3.3V SW	H	L	Z	K	
38	P12	I/O	O	DC/DC +8V SW	H	L	Z	K	
39	P13	I/O	O	NC	H	L	Z	K	
40	P14	I/O	O	Charge On/Off	H	L	Z	K	
41	P15	I/O	O	U	H	L	Z	K	for DIT
42	P16	I/O	O	V	H	L	Z	K	for DIT
43	P17	I/O	O	C	H	L	Z	K	for DIT
44	VSS	I	-	-					Ground
45	P20	I/O	I	ALT_SW 0 [INPUT SELECT]				Z	Z
46	P21	I/O	I	ALT_SW 1 [INPUT SELECT]				Z	K
47	P22	I/O	I	ALT_SW 2 [AUDIO QUALTY]				Z	K
48	P23	I/O	I	ALT_SW 3 [AUDIO QUALTY]				Z	K
49	P24	I/O	I	ALT_SW 4 [KEY LOCK]	L	Z	Z	K	CMOS Pull Up
50	P25	I/O	I	ALT_SW 5 [PREREC_EN]	L	Z	Z	K	CMOS Pull Up

No	Port name	I/O	USE	Sig. Name	ACT	INI	RST	STB	Description
51	P26	I/O	I	ALT_SW 6 [CHARGE_EN]	L		Z	K	CMOS Pull Up
52	P27	I/O	I	ALT_SW 7 [SPEAKER_ON]			Z	K	CMOS Pull Up
53	P50	I/O	I	MTRY_SW0 [MARKMODE]	L		Z	K	CMOS Pull Up
54	P51	I/O	I	MTRY_SW1 [DISPLAY]	L		Z	K	CMOS Pull Up
55	P52	I/O	I	MTRY_SW2 [TIME]	L		Z	K	CMOS Pull Up
56	P53	I/O	I	MTRY_SW3 [REMOTE IN]	L		Z	K	CMOS Pull Up
57	VSS	I	-	-					Ground
58	P60	I/O	O	TEL-MUTE	H	H	Z	K	Pull Down
59	P61	I/O	O	INTMIC-MUTE	H	H	Z	K	Pull Down
60	P62	I/O	O	LINE-MUTE	H	H	Z	K	Pull Down
61	CK	O	O	NC				O	H
62	STBY	I	I	-				I	I
63	RES	I	I	-				I	I
64	NMI	I	I	-				I	I
65	VSS	I	-	-					Ground
66	EXTAL	I	I	-				I	I
67	XTAL	O	O	-				O	O
68	VCC	I	-	-					+5V
69	P63	I/O	O	HP-MUTE	H	H	Z	K	Pull Down
70	P64	I/O	O	PWM-MUTE	H	H	Z	K	Pull Down
71	P65	I/O	O	SP-MUTEA	H	H	Z	K	Pull Down
72	P66	I/O	O	NC				L	Z
73	MD0	I	I	Mode Select 0				I	I
74	MD1	I	I	Mode Select 1				I	I
75	MD2	I	I	Mode Select 2				I	I
76	AVCC	I	-	-					+5V
77	AREFF	I	-	-					Regulated +5V
78	AN0	I/O	AN	Battery Voltage			Z	Z	Need dividing
79	AN1	I/O	AN	L Level			Z	Z	
80	AN2	I/O	AN	HiDC			Z	Z	Pull Up
81	P73	I/O	I	ACIN	L	Z	Z	Z	Pull Up
82	P74	I/O	I	SPK	L	Z	Z	Z	Pull Up
83	P75	I/O	I	HP	L	Z	Z	Z	Pull Up
84	P76	I/O	I	EXT_MIC	L	Z	Z	Z	Pull Up
85	P77	I/O	I	LIMIT_CHK			Z	Z	Pull Up
86	AVSS	I	-	-					Ground
87	_IRQ0	I/O	I	Power Switch	L	Z	Z	K	Pull Up
88	_IRQ1	I/O	I	from RTC 500msec	L	Z	Z	K	Pull Up
89	_IRQ2	I/O	I	Card	L	Z	Z	K	Pull Up
90	_IRQ3	I/O	O	Frame Counter	L	Z	Z	K	Pull Up
91	P84	I/O	O	NC			L	Z	K
92	VSS	I	-	-					Ground
93	PA0	I/O	O	_C7/_C3	L	H	Z	K	for DIT
94	PA1	I/O	O	PRO	L	H	Z	K	for DIT
95	PA2	I/O	O	_C1/FC0	L	H	Z	K	for DIT
96	PA3	I/O	O	_C6/_C2	L	H	Z	K	for DIT
97	PA4	I/O	O	_C9/_C15	L	H	Z	K	for DIT
98	PA5	I/O	O	EM1/_C8	L	H	Z	K	for DIT
99	TCIO2A	I/O	O	REC_LED (RED)	L	H	Z	K	
100	PA7	I/O	O	TRNPT/FC1	L	H	Z	K	for DIT

QS03:H8-3048 (PMD690 Only)

No	Port name	I/O	USE	Sig. Name	ACT	INI	RST	STB	Description
1	VCC	I	-	-					+5V
2	TIOCA3	I/O	O	PWM	-	L	Z	K	Buzzer
3	PB1	I/O	O	-	H	L	Z	K	
4	PB2	I/O	O	REC_N	H	L	Z	K	
5	PB3	I/O	O	ML	H	L	Z	K	for CODEC
6	PB4	I/O	O	MC	H	L	Z	K	for CODEC
7	PB5	I/O	O	MD	H	L	Z	K	for CODEC
8	PB6	I/O	I/O	I ² C Bus SDA	L	H	Z	K	Pull Up 22 kΩ
9	PB7	I/O	O	I ² C Bus SCL	L	H	Z	K	Pull Up 22 kΩ
10	VPP	I	-	for Flash Writing					+12V
11	VSS	I	-	-					Ground
12	TXD0	O	O	to LCD driver			Z	K	
13	TXD1	O	O	to Main MPU (RXD1)			Z	K	
14	RXD0	I	I	NC			Z	K	Pull Up
15	RXD1	I	I	from Main MPU (TXD1)			Z	K	
16	P94	I/O	O	LCD_R/W	L	H	Z	K	
17	SCK0	I/O	O	to LCD driver			Z	K	
18	P40	I/O	I	KEY IN 0	L	Z	Z	K	CMOS Pull Up
19	P41	I/O	I	KEY IN 1	L	Z	Z	K	CMOS Pull Up
20	P42	I/O	I	KEY IN 2	L	Z	Z	K	CMOS Pull Up
21	P43	I/O	I	KEY IN 3	L	Z	Z	K	CMOS Pull Up
22	VSS	I	-	-					Ground
23	P44	I/O	O	+48V Control	H	L	Z	K	
24	P45	I/O	O	Phantom Mute Out	H	L	Z	K	
25	P46	I/O	O	L+R/2 Out	H	H	Z	K	
26	P47	I/O	O	ST_MO_INT	H	H	Z	K	
27	P30	I/O	O	KEY SCAN 0	L	H	Z	K	
28	P31	I/O	O	KEY SCAN 1	L	H	Z	K	
29	P32	I/O	O	KEY SCAN 2	L	H	Z	K	
30	P33	I/O	O	KEY SCAN 3	L	H	Z	K	
31	P34	I/O	O	LL	H	L	Z	K	
32	P35	I/O	O	EM0/_C9	L	H	Z	K	for DIT
33	P36	I/O	O	LCD BACK LIGHT	H	L	Z	K	
34	P37	I/O	O	LCD_INH	L	H	Z	K	
35	VCC	I	-	-					+5V
36	P10	I/O	O	DC/DC +5V SW	H	L	Z	K	
37	P11	I/O	O	DC/DC +3.3V SW	H	L	Z	K	
38	P12	I/O	O	DC/DC +-8V SW	H	L	Z	K	
39	P13	I/O	O	NC	H	L	Z	K	
40	P14	I/O	O	Charge On/Off	H	L	Z	K	
41	P15	I/O	O	U	H	L	Z	K	for DIT
42	P16	I/O	O	V	H	L	Z	K	for DIT
43	P17	I/O	O	C	H	L	Z	K	for DIT
44	VSS	I	-	-					Ground
45	P20	I/O	I	ALT_SW 0 [Int MIC/St/Mono]			Z	Z	
46	P21	I/O	I	ALT_SW 1[Int MIC/St/Mono]			Z	K	CMOS Pull Up
47	P22	I/O	I	ALT_SW 2 [AUDIO QUALTY]			Z	K	CMOS Pull Up
48	P23	I/O	I	ALT_SW 3 [AUDIO QUALTY]			Z	K	CMOS Pull Up
49	P24	I/O	I	ALT_SW 4 [KEY LOCK]	L	Z	Z	K	CMOS Pull Up
50	P25	I/O	I	ALT_SW 5 [PREREC_EN]	L	Z	Z	K	CMOS Pull Up

No	Port name	I/O	USE	Sig. Name	ACT	INI	RST	STB	Description	
51	P26	I/O	I	ALT_SW 6 [CHARGE_EN]	L		Z	K	CMOS Pull Up	
52	P27	I/O	O	Mode (PMD680/PMD690)	L		Z	K	CMOS Pull Up	
53	P50	I/O	I	MTRY_SW0 [MARKMODE]	L		Z	K	CMOS Pull Up	
54	P51	I/O	I	MTRY_SW1 [DISPLAY]	L		Z	K	CMOS Pull Up	
55	P52	I/O	I	MTRY_SW2 [TIME]	L		Z	K	CMOS Pull Up	
56	P53	I/O	I	MTRY_SW3 [REMOTE IN]	L		Z	K	CMOS Pull Up	
57	VSS	I	-	-					Ground	
58	P60	I/O	O	-	H	H	Z	K	Pull Down	
59	P61	I/O	O	INTMIC-MUTE	H	H	Z	K	Pull Down	
60	P62	I/O	O	LINE-MUTE	H	H	Z	K	Pull Down	
61	CK	O	O	NC			O	H		
62	STBY	I	I	-			I	I	Pull Up	
63	RES	I	I	-			I	I	Pull Up	
64	NMI	I	I	-			I	I	Pull Up	
65	VSS	I	-	-					Ground	
66	EXTAL	I	I	-			I	I	16MHz	
67	XTAL	O	O	-			O	O	16MHz	
68	VCC	I	-	-					+5V	
69	P63	I/O	O	HP-MUTE	H	H	Z	K	Pull Down	
70	P64	I/O	O	PWM-MUTE	H	H	Z	K	Pull Down	
71	P65	I/O	O	SP-MUTEA	H	H	Z	K	Pull Down	
72	P66	I/O	O	NC			L	Z	K	Pull Down
73	MD0	I	I	Mode Select 0			I	I	Mode 7	
74	MD1	I	I	Mode Select 1			I	I	Mode 7	
75	MD2	I	I	Mode Select 2			I	I	Mode 7	
76	AVCC	I	-	-					+5V	
77	AREFF	I	-	-					Regulated +5V	
78	AN0	I/O	AN	Battery Voltage			Z	Z	Need dividing	
79	AN1	I/O	AN	L Level			Z	Z		
80	AN2	I/O	AN	R Level			Z	Z	Pull Up	
81	P73	I/O	I	ACIN	L		Z	Z	Pull Up	
82	P74	I/O	I	NC			Z	Z	Pull Up	
83	P75	I/O	I	HP	L		Z	Z	Pull Up	
84	P76	I/O	I	NC			Z	Z	Pull Up	
85	P77	I/O	I	LIMIT_CHK			Z	Z	Pull Up	
86	AVSS	I	-	-					Ground	
87	_IRQ0	I/O	I	Power Switch	L		Z	K	Pull Up	
88	_IRQ1	I/O	I	Phantom-MUTE	L		Z	K	Pull Up	
89	_IRQ2	I/O	I	Card	L		Z	K	Pull Up	
90	_IRQ3	I/O	O	Frame Counter	L		Z	K	Pull Up	
91	P84	I/O	I	NC			Z	K		
92	VSS	I	-	-					Ground	
93	PA0	I/O	O	_C7/_C3	L	H	Z	K	for DIT	
94	PA1	I/O	O	PRO	L	H	Z	K	for DIT	
95	PA2	I/O	O	_C1/FC0	L	H	Z	K	for DIT	
96	PA3	I/O	O	_C6/_C2	L	H	Z	K	for DIT	
97	PA4	I/O	O	_C9/_C15	L	H	Z	K	for DIT	
98	PA5	I/O	O	EM1/_C8	L	H	Z	K	for DIT	
99	TCIO2A	I/O	O	REC LED (RED)	L	H	Z	K		
100	PA7	I/O	O	TRNPT/FC1	L	H	Z	K	for DIT	

QU02:SH-7709

no	port name	I/O	USE	Sig. Name	ACT	INI	RST	Description
1	MD1	I	-	Mode Select 1			I	Pull Down
2	MD2	I	-	Mode Select 2			I	Pull Down
3	VCC(RTC)	I	-	RTC VCC			-	+3.3V
4	XTAL2	O	-	OSC IN for RTC			O	32kHz
5	EXTAL2	I	-	OSC OUT for RTC			I	32kHz
6	VSS(RTC)	I	-	RTC VSS			-	Ground
7	NMI	I	NMI	-			I	Pull Up
8	IRL0	I	I	Interruption Decoder			V	
9	IRL1	I	I	Interruption Decoder			V	
10	IRL2	I	I	Interruption Decoder			V	
11	IRL3	I	I	Interruption Decoder			V	
12	IRQ4	I/O	I	External Interruption 4			V	
13	D31	I/O	I/O	Data Bus Bit 31			Z	
14	D30	I/O	I/O	Data Bus Bit 30			Z	
15	D29	I/O	I/O	Data Bus Bit 29			Z	
16	D28	I/O	I/O	Data Bus Bit 28			Z	
17	D27	I/O	I/O	Data Bus Bit 27			Z	
18	D26	I/O	I/O	Data Bus Bit 26			Z	
19	VSS	I	-	-			-	Ground
20	D25	I/O	I/O	Data Bus Bit 25			Z	
21	VCC	I	-	-			-	+3.3V
22	D24	I/O	I/O	Data Bus Bit 24			Z	
23	D23	I/O	I/O	Data Bus Bit 23			Z	
24	D22	I/O	I/O	Data Bus Bit 22			Z	
25	D21	I/O	I/O	Data Bus Bit 21			Z	
26	D20	I/O	I/O	Data Bus Bit 20			Z	
27	VSS	I	-	-			-	Ground
28	D19	I/O	I/O	Data Bus Bit 19			Z	
29	VCC	I	-	-			-	+3.3V
30	D18	I/O	I/O	Data Bus Bit 18			Z	
31	D17	I/O	I/O	Data Bus Bit 17			Z	
32	D16	I/O	I/O	Data Bus Bit 16			Z	
33	VSS	I	-	-			-	Ground
34	D15	I/O	I/O	Data Bus Bit 15			Z	
35	VCC	I/O	-	-			-	+3.3V
36	D14	I/O	I/O	Data Bus Bit 14			Z	
37	D13	I/O	I/O	Data Bus Bit 13			Z	
38	D12	I/O	I/O	Data Bus Bit 12			Z	
39	D11	I/O	I/O	Data Bus Bit 11			Z	
40	D10	I/O	I/O	Data Bus Bit 10			Z	
41	D9	I/O	I/O	Data Bus Bit 9			Z	
42	D8	I/O	I/O	Data Bus Bit 8			Z	
43	D7	I/O	I/O	Data Bus Bit 7			Z	
44	D6	I/O	I/O	Data Bus Bit 6			Z	
45	VSS	I	-	-			-	Ground
46	D5	I/O	I/O	Data Bus Bit 5			Z	
47	VCC	I	-	-			-	+3.3V
48	D4	I/O	I/O	Data Bus Bit 4			Z	
49	D3	I/O	I/O	Data Bus Bit 3			Z	
50	D2	I/O	I/O	Data Bus Bit 2			Z	
51	D1	I/O	I/O	Data Bus Bit 1			Z	
52	D0	I/O	I/O	Data Bus Bit 0			Z	

no	port name	I/O	USE	Sig. Name	ACT	INI	RST	Description
53	A0	O	O	Address Bus Bit 0			Z	
54	A1	O	O	Address Bus Bit 1			Z	
55	A2	O	O	Address Bus Bit 2			Z	
56	A3	O	O	Address Bus Bit 3			Z	
57	VSS	I	-	-			-	Ground
58	A4	O	O	Address Bus Bit 4			Z	
59	VCC	I	-	-			-	+3.3V
60	A5	O	O	Address Bus Bit 5			Z	
61	A6	O	O	Address Bus Bit 6			Z	
62	A7	O	O	Address Bus Bit 7			Z	
63	A8	O	O	Address Bus Bit 8			Z	
64	A9	O	O	Address Bus Bit 9			Z	
65	A10	O	O	Address Bus Bit 10			Z	
66	A11	O	O	Address Bus Bit 11			Z	
67	A12	O	O	Address Bus Bit 12			Z	
68	A13	O	O	Address Bus Bit 13			Z	
69	VSS	I	-	-			-	Ground
70	A14	O	O	Address Bus Bit 14			Z	
71	VCC	I	-	-			-	+3.3V
72	A15	O	O	Address Bus Bit 15			Z	
73	A16	O	O	Address Bus Bit 16			Z	
74	A17	O	O	Address Bus Bit 17			Z	
75	A18	O	O	Address Bus Bit 18			Z	
76	A19	O	O	Address Bus Bit 19			Z	
77	A20	O	O	Address Bus Bit 20			Z	
78	A21	O	O	Address Bus Bit 21			Z	
79	VSS	I	-	-			-	Ground
80	A22	O	O	Address Bus Bit 22			Z	
81	VCC	I	-	-			-	+3.3V
82	A23	O	O	Address Bus Bit 23			Z	
83	VSS	I	-	-			-	Ground
84	A24	O	O	Address Bus Bit 24			Z	
85	VCC	I	-	-			-	+3.3V
86	A25	O	O	Address Bus Bit 25			Z	
87	_BS	O	O	for PCIC			-	
88	_RD	O	O	Read Enable			H	
89	_WE0	O	O	Write Enable 0			H	
90	_WE1	O	O	Write Enable 1			H	
91	_WE2	O	O	Write Enable 2			H	
92	_WE3	O	O	Write Enable 3			H	
93	RD/_WE	O	O	Read/Write direction			H	
94	PTE7	I/O	O	NC			L	V
95	VSS	I	-	-			-	Ground
96	_CS0	O	O	Chip Select for ROM			H	
97	VCC	I	-	-			-	+3.3V
98	_CS2	O	O	Chip Select 2			H	
99	_CS3	O	O	Chip Select 3			H	
100	_CS4	O	O	Chip Select 4			H	
101	_CS5	I	-	Chip Select for CPLD			H	S/P, P/S converter
102	_CS6	O	O	Chip Select for PCIC			H	
103	_CE2A	O	O	for PCIC			V	
104	_CE2B	O	O	for PCIC			V	

QU02:SH-7709

no	port name	I/O	USE	Sig. Name	ACT	INI	RST	Description
105	PTK5	I/O	O	NC		L	H	
106	RAS3L	O	O	RAS3 Lower			H	for DRAM
107	PTJ1	I/O	O	NC		L	H	
108	CASLL	O	O	CAS Lower/Lower			H	for DRAM
109	VSS	I	-	-			-	Ground
110	CASLH	O	O	CAS Lower/Upper			H	for DRAM
111	VCC	I	-	-			-	+3.3V
112	CASHL	O	O	CAS Upper/Lower			H	for DRAM
113	CASHH	O	O	CAS Upper/Upper			H	for DRAM
114	PTD7	I/O	O	NC		L	V	-
115	DACK0	I/O	O	DMA Acknowledge	H	L	V	for P/S converter
116	PTE6	I/O	O	NC		L	V	-
117	PTE3	I/O	O	NC		L	V	-
118	RAS3U	O	O	RAS3 Upper			V	-
119	PTE1	I/O	O	NC		L	V	-
120	PTE0	I/O	O	NC		L	V	-
121	_BACK	O	O	NC			O	-
122	_BREQ	I	I	Bus Request			I	Pull Up
123	_WAIT	O	O	NC			-	-
124	_RESETM	I	I	-			I	Pull Up
125	PTH5	I	I	NC			V	COMS Pull Up
126	PTG7	I	I	NC			V	COMS Pull Up
127	PTG6	I	I	NC			V	COMS Pull Up
128	PTG5	I	I	NC			V	COMS Pull Up
129	PTG4	I	I	NC			V	COMS Pull Up
130	PTG3	I	I	NC			V	COMS Pull Up
131	PTG2	I	I	NC			V	COMS Pull Up
132	VSS	I/O	I	-			-	Ground
133	PTG1	I	I	NC			V	COMS Pull Up
134	VCC	I	-	-			-	+3.3V
135	PTG0	I	I	NC			V	COMS Pull Up
136	PTF7	I	I	NC			V	CMOS Pull Up
137	PTF6	I	I	NC			V	CMOS Pull Up
138	PTF5	I	I	NC			V	CMOS Pull Up
139	PTF4	I	I	NC			V	CMOS Pull Up
140	PTF3	I	I	NC			V	CMOS Pull Up
141	PTF2	I	I	DSP status		L	V	Pull Down
142	INT9	I	I	Interrupt of Packet End		L	V	CMOS Pull Up
143	PTF0	I	I	NC			V	CMOS Pull Up
144	MD0	I	I	Mode Select 0			I	Pull Down
145	VCC	I	-	for PLL1			-	+3.3V
146	CAP1	I	O	-			-	-
147	VSS	I/O	-	for PLL1			-	Ground
148	VSS	I/O	-	for PLL2			-	Ground
149	CAP2	I	I	-			-	-
150	VCC	I	-	for PLL2			-	+3.3V
151	PTH6	I	I	NC			V	CMOS Pull Up
152	VSS	I	-	-			-	Ground
153	VSS	I	-	-			-	Ground
154	VCC	I	-	-			-	+3.3V
155	XTAL	I	I	-			-	20MHz
156	EXTAL	O	O	NC			-	-

no	port name	I/O	USE	Sig. Name	ACT	INI	RST	Description
157	PTJ6	I/O	O	-		L	L	
158	PTJ7	I/O	O	-		L	L	
159	PTH7	I	I	NC			V	CMOS Pull Up
160	_IRQOUT	I/O	O	NC			O	-
161	VSS	I	-	-			-	Ground
162	CKIO	O	O	-			O	20MHz
163	VCC	I	-	-			-	Ground
164	TXD0	O	O	for DSP			Z	-
165	SCK0	I/O	O	for DSP			V	-
166	TXD1	O	O	for Sub MPU			Z	-
167	SCK1	O	I	NC			V	-
168	TXD2	O	O	for OS-9 debug			Z	-
169	SCK2	I/O	I	NC			V	Pull UP
170	RTS2	O	O	NC			-	-
171	RXD0	I/O	I	for DSP			Z	-
172	RXD1	I/O	O	for Sub MPU			Z	-
173	VSS	I	-	-			-	Ground
174	RXD2	I/O	I	for OS-9 debug			Z	-
175	VCC	I	-	-			-	+3.3V
176	CTS2	I/O	O	NC			V	-
177	PTC7	I/O	O	Request Command	L	H	V	-
178	PTC6	I/O	O	Reset for DSP	L	H	V	-
179	PTC5	I/O	O	BOOT		H	V	-
180	PTC4	I/O	O	FSK	H	L	V	-
181	VSS	I/O	O	-			-	-
182	PTD3	I/O	O	NC			V	-
183	VCC	I/O	I	-			-	-
184	PTD2	I/O	O	NC			V	-
185	PTC3	I/O	O	SEL		H	V	-
186	PTC2	I/O	O	Request Boot	L	H	V	-
187	PTC1	I/O	O	NC			V	-
188	PTC0	I/O	O	Stop Request	L	H	V	-
189	PTD1	I/O	O	NC			V	-
190	PTD0	I/O	O	Start Clock	H	L	V	-
191	_DREQ0	I	I	for P/S converter	L		V	CMOS Pull Up
192	_DREQ1	I	I	for S/P converter			V	CMOS Pull Up
193	_RESETP	O	-	-			I	Pull Up
194	_CA	I	-	-			I	Pull Up
195	MD3	I	I	Mode Select 3			I	Pull Up
196	MD4	I	I	Mode Select 4			I	Pull Up
197	MD5	I	I	Mode Select 5			I	Pull Down
198	AVSS	I	-	-			-	Ground
199	PTL0	I	I	NC			Z	Pull Up
200	PTL1	I	I	NC			Z	Pull Up
201	PTL2	I	I	NC			Z	Pull Up
202	PTL3	I	I	NC			Z	Pull Up
203	PTL4	I	I	NC			Z	Pull Up
204	PTL5	I	I	NC			Z	Pull Up
205	AVCC	I	-	NC			-	+3.3V
206	PTL6	I	I	NC			Z	Pull Up
207	PTL7	I	I	NC			Z	Pull Up
208	AVSS	I	-	-			-	Ground

Q602:TMS320C31-60

no	port name	I/O	USE	Sig. Name	ACT	INI	RST	Description
1	A21	O	O	Address Bus Bit 21			Z	
2	A20	O	O	Address Bus Bit 20			Z	
3	VSS	I	-				-	
4	VSS	I	-				-	
5	A19	O	O	Address Bus Bit 19			Z	
6	VDD	I	-				-	
7	A18	O	O	Address Bus Bit 18			Z	
8	A17	O	O	Address Bus Bit 17			Z	
9	A16	O	O	Address Bus Bit 16			Z	
10	A15	O	O	Address Bus Bit 15			Z	
11	A14	O	O	Address Bus Bit 14			Z	
12	A13	O	O	Address Bus Bit 13			Z	
13	A12	O	O	Address Bus Bit 12			Z	
14	A11	O	O	Address Bus Bit 11			Z	
15	VCC	I	-				-	
16	A10	O	O	Address Bus Bit 10			Z	
17	VSS	I	-				-	
no	port name	I/O	USE	Sig. Name	ACT	INI	RST	Description
18	A9	O	O	Address Bus Bit 9			Z	
19	VSS	I	-				-	
20	A8	O	O	Address Bus Bit 8			Z	
21	A7	O	O	Address Bus Bit 7			Z	
22	A6	O	O	Address Bus Bit 6			Z	
23	A5	O	O	Address Bus Bit 5			Z	
24	VCC	I	-				-	
25	A4	O	O	Address Bus Bit 4			Z	
26	A3	O	O	Address Bus Bit 3			Z	
27	A2	O	O	Address Bus Bit 2			Z	
28	A1	O	O	Address Bus Bit 1			Z	
29	A0	O	O	Address Bus Bit 0			Z	
30	VSS	I	-				-	
31	D31	I/O	I/O	Data Bus Bit 31			Z	
32	VCC	I	-				-	
33	VCC	I	-				-	
34	D30	I/O	I/O	Data Bus Bit 30			Z	
35	VSS	I	-				-	
36	VSS	I	-				-	
37	VSS	I	-				-	
38	D29	I/O	I/O	Data Bus Bit 29			Z	
39	D28	I/O	I/O	Data Bus Bit 28			Z	
40	VCC	I	-				-	
41	D27	I/O	I/O	Data Bus Bit 27			Z	
42	VCC	I	-				-	
43	D26	I/O	I/O	Data Bus Bit 26			Z	
44	D25	I/O	I/O	Data Bus Bit 25			Z	
45	D24	I/O	I/O	Data Bus Bit 24			Z	
46	D23	I/O	I/O	Data Bus Bit 23			Z	
47	D22	I/O	I/O	Data Bus Bit 22			Z	
48	D21	I/O	I/O	Data Bus Bit 21			Z	
49	VCC	I	-				-	
50	D20	I/O	I/O	Data Bus Bit 20			Z	

no	port name	I/O	USE	Sig. Name	ACT	INI	RST	Description
51	VSS	I	-				-	
52	D19	I/O	I/O	Data Bus Bit 19			Z	
53	D18	I/O	I/O	Data Bus Bit 18			Z	
54	D17	I/O	I/O	Data Bus Bit 17			Z	
55	D16	I/O	I/O	Data Bus Bit 16			Z	
56	D15	I/O	I/O	Data Bus Bit 15			Z	
57	VSS	I/O					-	
58	D14	I/O	I/O	Data Bus Bit 14			Z	
59	VCC	I	-				-	
60	D13	I/O	I/O	Data Bus Bit 13			Z	
61	VSS	I	-				Z	
62	D12	I/O	I/O	Data Bus Bit 12			Z	
63	D11	I/O	I/O	Data Bus Bit 11			Z	
64	D10	I/O	I/O	Data Bus Bit 10			Z	
65	VCC	I/O	-				-	
66	VCC	I/O	-				-	
67	D9	I/O	I/O	Data Bus Bit 9			Z	
68	D8	I/O	I/O	Data Bus Bit 8			Z	
69	VSS	I	-				-	Ground
70	VSS	I	-				-	Ground
71	VSS	I	-				-	Ground
72	D7	I/O	I/O	Data Bus Bit 7			Z	
73	D6	I/O	I/O	Data Bus Bit 6			Z	
74	VCC	I	-				-	+5V
75	D5	I/O	I/O	Data Bus Bit 5			Z	
76	D4	I/O	I/O	Data Bus Bit 4			Z	
77	D3	I/O	I/O	Data Bus Bit 3			Z	
78	D2	I/O	I/O	Data Bus Bit 2			Z	
79	D1	I/O	I/O	Data Bus Bit 1			Z	
80	D0	I/O	I/O	Data Bus Bit 0			Z	
81	H1	O	O	NC			-	
82	H3	O	O	NC			-	
83	VCC	I	-				-	+5V

no	port name	I/O	USE	Sig. Name	ACT	INI	RST	Description
84	VSS	I	-				-	Ground
85	VSS	I	-				-	Ground
86	VSS	I	-				-	Ground
87	X2/CLKIN	O	O	NC			-	
88	X1	I	I	OSC input			-	60MHz
89	_HOLDA	O	O	NC			-	
90	_HOLD	I	I				-	Pull Up
91	VCC	I	-				-	+5V
92	_RDY	I	I				-	Pull Up
93	_STRB	O	O				-	
94	R_W	O	O				Z	
95	_RESET	I	I				-	Pull Up
96	XF0	I/O	O		H	L	Z	
97	VCC	I	-				-	+5V
98	XF1	I/O	O		H	L	Z	Pull Down
99	_IACK	O	O				-	
100	_INT0	I	I				-	Pull Up
101	VSS	I	-				-	Ground
102	VSS	I	-				-	Ground
103	_INT1	I	I				-	Pull Up
104	VCC	I	-				-	+5V
105	VCC	I	-				-	+5V
106	_INT2	I	I				-	Pull Up
107	_INT3	I	I				-	Pull Up
108	DR0	I/O	I				Z	Pull Down
109	VSS	I	-				-	Ground
110	FSR0	I/O	I				Z	Pull Down
111	CLKR0	I/O	I				Z	Pull Down
112	CLKX0	I/O	O				Z	Pull Down
113	VSS	I	-				-	Ground
114	FSX0	I/O	O				Z	Pull Down
115	VCC	I	-				-	+5V
116	DX0	I/O	O				Z	Pull Down
no	port name	I/O	USE	Sig. Name	ACT	INI	RST	Description
117	VSS	I	-				-	Ground
118	_SHZ	I	I				-	Pull Up
119	VSS	I	-				-	Ground
120	TCLK0	I/O	O		H	H	-	
121	VCC	I	-				-	+5V
122	TCLK1	I/O	O		H	H	-	
123	EMU3	O	O	JTAG debug port			-	
124	EMU0	I	I	JTAG debug port			-	Pull Up 20k ohm
125	EMU1	I	I	JTAG debug port			-	Pull Up 20k ohm
126	EMU2	I	I	JTAG debug port			-	Pull Up 20k ohm
127	MCBL_MP	I	I				-	Pull Up
128	VSS	I	-				-	
129	A23	O	O	Address Bus Bit 23			Z	
130	A22	O	O	Address Bus Bit 22			Z	
131	VCC	I	-				-	+5V
132	VCC	I	-				-	+5V

7. EXPLODED VIEW AND PARTS LIST

PMD680 Only

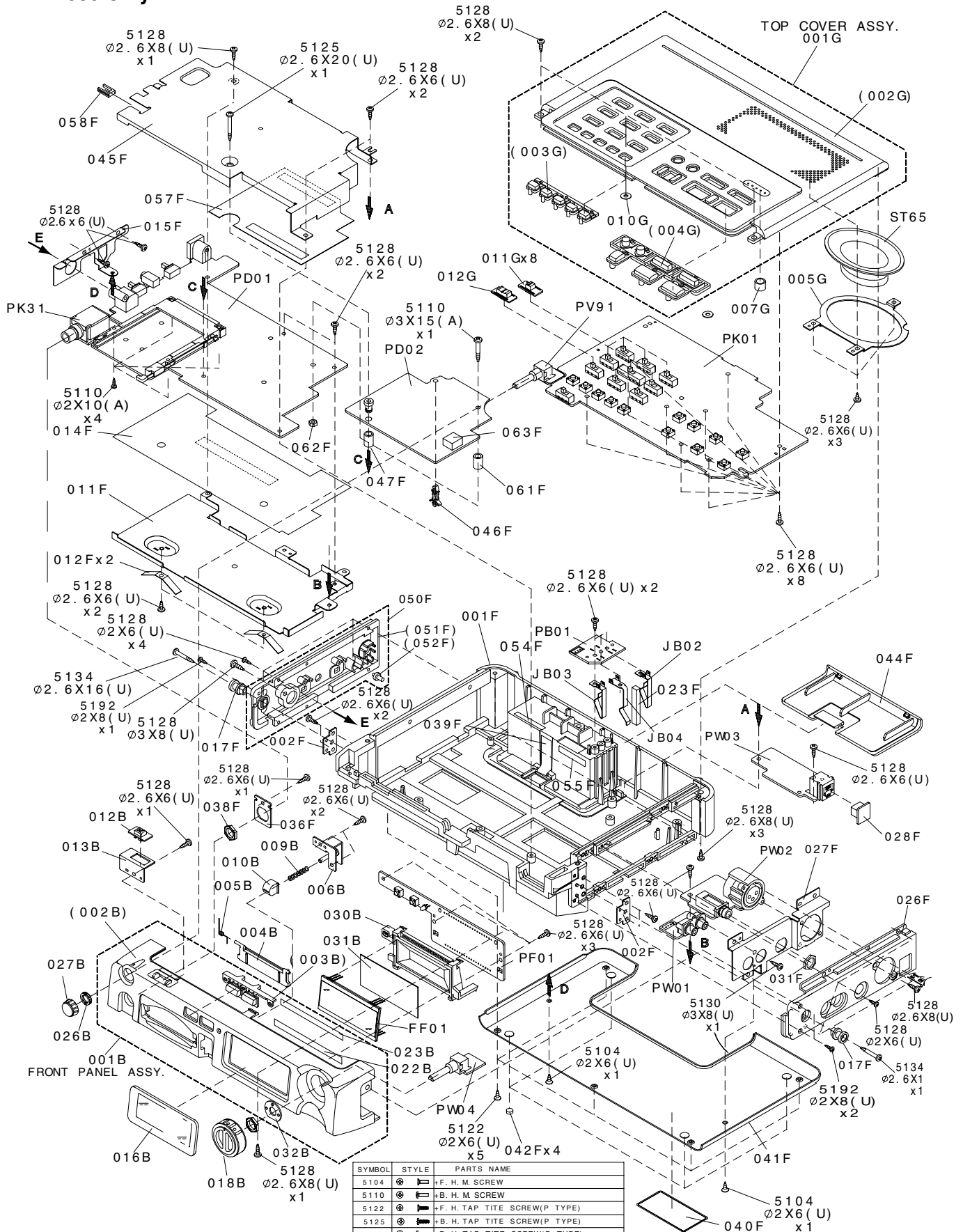

MARK	MATERIAL / FINISH
(U)	STEEL / BLACK
(A)	STEEL / CHROMATE

SYMBOL	STYLE	PARTS NAME
5104		+F. H. M. SCREW
5110		+B. H. M. SCREW
5122		+F. H. TAP TITE SCREW(P TYPE)
5125		+B. H. TAP TITE SCREW(P TYPE)
5128		+B. H. TAP TITE SCREW(B TYPE)
5130		+P. H. TAP TITE SCREW(B TYPE)
5134		+F. H. TAP TITE SCREW(B TYPE)
5192		+P. H. (P) TAP TITE SCREW(B TYPE)

POS. NO	VERS. COLOR	PART NO. (FOR PCS)	DESCRIPTION	PART NO. (MJI)	POS. NO	VERS. COLOR	PART NO. (FOR PCS)	DESCRIPTION	PART NO. (MJI)
001B		9965 000 08871	FRONT PANEL ASSY	378V248500	MS01		4822 242 30206	MIC.UNIT ECM	MS50000150
002B			FRONT PANEL	nsp	MS02		9965 000 08902	SPEAKER 2x3IN 4 0.5W	QJ71487010
003B			BUTTON FR	nsp	WA02		9965 000 08903	JUMPER LEAD	YU18140500
004B		9965 000 08872	LID EJECT DOOR	378V257010				FFC 18P JS54-JA54	
005B		9965 000 08873	SPRING DOOR	378V115020	WF01		4822 321 62965	JUMPER LEAD	YU10110500
006B		9965 000 08874	BRACKET ASSY EJECT	378V160500				FFC 10P JF01-JS02	
009B		9965 000 08875	SPRING EJECT KNOB	378V115010	WY01		9965 000 08903	JUMPER LEAD	YU18140500
010B		9965 000 08876	KNOB EJECT	378V154020				FFC 18P JS01-JY01	
012B		9965 000 08877	KNOB POWER	378V154060					
013B			BRACKET POWER	nsp					
016B		9965 000 08878	WINDOW	378V158010	001T	/F		PACKING	378V851110
018B		9965 000 08879	KNOB REC.VOL. ASSY	377V154500	001T	/U		USER MANUAL	378V851250
022B			INSULATOR 73X5	nsp	001T	/W	9965 000 08887	USER MANUAL	378V851310
023B			INSULATOR 67X5.4	nsp					
026B			CIRCULAR NUT	nsp	001Z		4822 498 20097	STRAP	153T156010
027B		9965 000 03148	KNOB PHONE VOL.	378V154040	005Z		9965 000 03179	BATT.CASE ASSY	377V064500
030B			HOLDER LCD	nsp	▲ 010Z	/F		A.C ADAPTOR	AA10013040
031B			INTRODUCER	nsp				DA600PMDF 13V 1.0A	
032B			RETAINER REC LEVEL VOL	nsp	▲ 010Z	/U		A.C ADAPTOR	AA12013020
								DA600PMDU 13V 1.0A	
001F		9965 000 08880	FRAME MAIN	378V401010					
002F			BRACKET STRAP	nsp					
011F			SHIELD CASE BOTTOM	nsp					
012F			SPRING LEAF	nsp					
014F			INSULATOR BOTTOM SHIELD	nsp					
015F			BRACKET SIDE L	nsp					
017F		9965 000 03154	SUPPORT STRAP	378V101020					
023F			BUFFER FOR CONTACTOR	nsp					
026F	/F, /W	9965 000 08881	SIDE PANEL R W F	377V249010					
026F	/U		SIDE PANEL R U	377V249020					
027F			BRACKET SIDE R	nsp					
028F		9965 000 08882	CAP TEL CAP	457S067010					
031F			NUT MIC	nsp					
036F			BRACKET PHONE	nsp					
038F			NUT PHONE JACK	nsp					
039F			TAPE BATTERY EJECT	nsp					
040F	/U		LABEL FOR 041F	nsp					
040F	/W		LABEL FOR 041F	nsp					
041F		9965 000 08883	COVER BOTTOM COVER ALL	378V053430					
042F		4822 462 42119	LEG	022D057020					
044F		9965 000 03161	COVER BATTERY COVER	378V053030					
045F			SHIELD CASE UPPER	nsp					
046F			SUPPORT PCB	nsp					
047F			SUPPORT PCB COLLAR BUSH	nsp					
050F		9965 000 08884	SIDE PANEL ASSY	457S249500					
051F			SIDE PANEL	nsp					
052F			LENS	nsp					
054F			LABEL FUSE CAUTION	nsp					
055F			LABEL FUSE CAUTION	nsp					
057F			INSULATOR SHIELD UPPER	nsp					
058F			WIRE CLAMPER	nsp					
061F			COLLAR SPACER PD01+PD02	nsp					
062F			HEXAGON NUT PD01+PD02	nsp					
063F			BUFFER FOR PD02	nsp					
001G	/F, /W	9965 000 08885	TOP COVER ASSY	378V053510					
001G	/U		TOP COVER ASSY	378V053500					
002G	/F, /W		TOP COVER	nsp					
002G	/U		TOP COVER	nsp					
003G			BUTTON A	nsp					
004G			BUTTON B	nsp					
005G			BRACKET SPEAKER	nsp					
007G			BUSH MIC	nsp					
010G			SPACER FOR PCB	nsp	001S			NOT STANDARD	
011G		9965 000 03163	KNOB SLIDE	378V154030	002S			SPEAR PARTS	
012G		9965 000 08886	KNOB KEY LOCK	378V154070	003S			CUSHION SET	378V809010
					010S			CUSHION TOP	378V809020
								PACKING CASE	457S801010
								MASTER CARTON	457S805010

NOTE : "nsp" PART IS LISTED FOR REFERENCE ONLY, MARANTZ WILL NOT SUPPLY THESE PARTS.

PMD690 Only

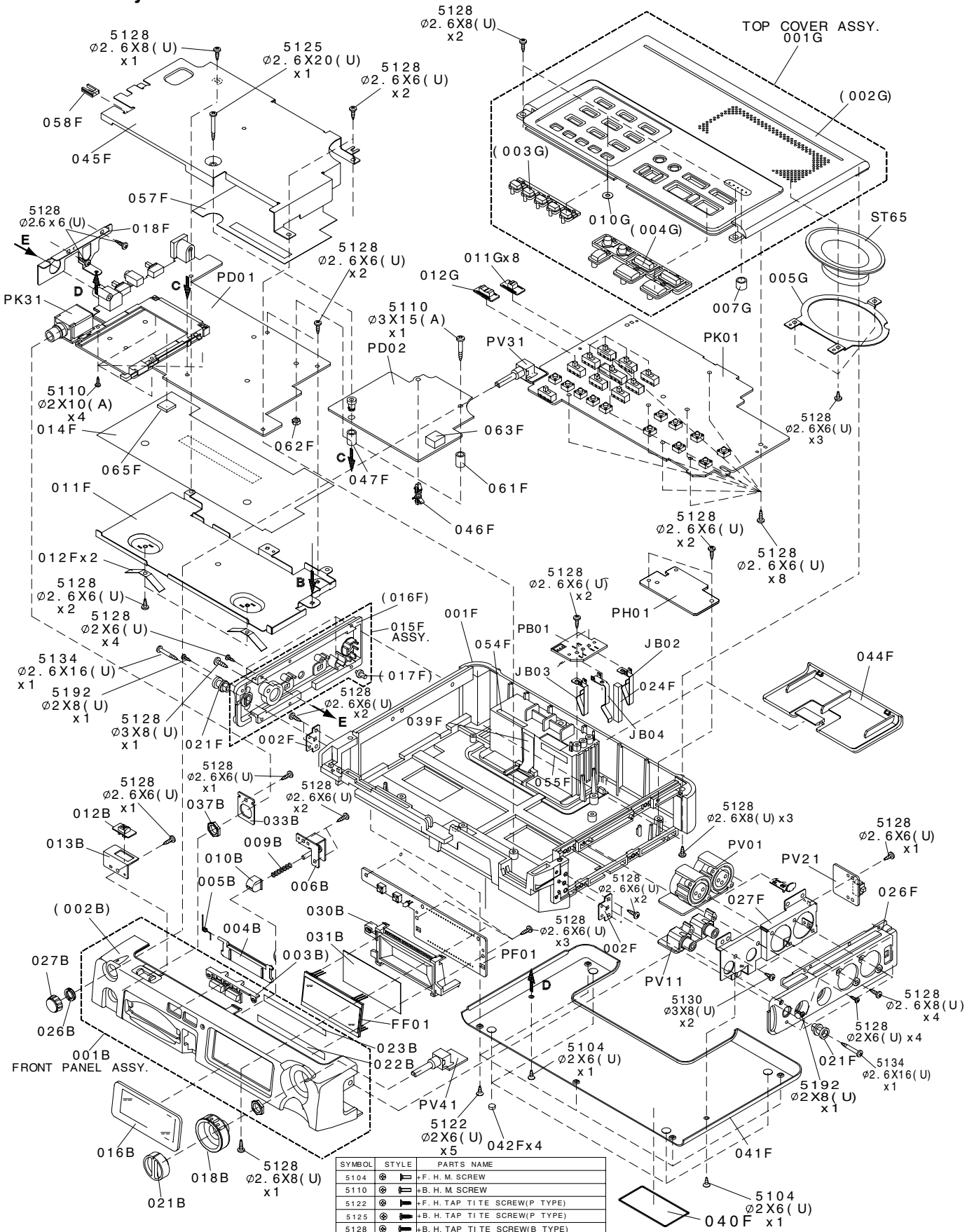

MARK	MATERIAL / FINISH
(U)	STEEL / BLACK
(A)	STEEL / CHROMATE

SYMBOL	STYLE	PARTS NAME
5104		+F. H. M. SCREW
5110		+B. H. M. SCREW
5122		+F. H. TAP TITE SCREW(P TYPE)
5125		+B. H. TAP TITE SCREW(P TYPE)
5128		+B. H. TAP TITE SCREW(B TYPE)
5130		+P. H. TAP TITE SCREW(B TYPE)
5134		+F. H. TAP TITE SCREW(B TYPE)
5192		+P. H. (調整) TAP TITE SCREW(B TYPE)

POS. NO	VERS. COLOR	PART NO. (FOR PCS)	DESCRIPTION	PART NO. (MJI)	POS. NO	VERS. COLOR	PART NO. (FOR PCS)	DESCRIPTION	PART NO. (MJI)
001B		9965 000 08888	FRONT PANEL ASSY	378V248510	MS01		4822 242 30206	MIC.UNIT ECM	MS50000150
002B			FRONT PANEL	nsp	MS02		9965 000 08902	SPEAKER 2X3IN 4 0.5W	QJ71487010
003B			BUTTON FR	nsp	WA02		9965 000 08903	JUMPER LEAD	YU18140500
004B		9965 000 08872	LID EJECT DOOR	378V257010				JK03-JS54 FFC 18P	
005B		9965 000 08873	SPRING DOOR	378V115020	WF01		4822 321 62965	JUMPER LEAD	YU10110500
006B		9965 000 08874	BRACKET ASSY EJECT	378V160500				JF01-JS02 FFC 10P	
009B		9965 000 08875	SPRING EJECT KNOB	378V115010	WY01		9965 000 08903	JUMPER LEAD	YU18140500
010B		9965 000 08876	KNOB EJECT	378V154020				JY01-JS01 FFC 18P	
012B		9965 000 08877	KNOB POWER	378V154060					
013B			BRACKET POWER	nsp				PACKING	
016B		9965 000 08878	WINDOW	378V158010	001T	/F		USER MANUAL	470S851110
018B		9965 000 03147	KNOB REC.VOL. L ASSY	409S154540	001T	/U		USER MANUAL	470S851250
021B		9965 000 03146	KNOB REC VOL R	409S154030	001T	/W	9965 000 08891	USER MANUAL	470S851310
022B			INSULATOR 73X6	nsp					
023B			INSULATOR 67X5.5	nsp	001Z		4822 498 20097	STRAP	153T156010
026B		9965 000 03149	CIRCULAR NUT	53218069E0	005Z		9965 000 03179	BATT.CASE ASSY	377V064500
027B		9965 000 03148	KNOB PHONE VOL	378V154040	▲ 010Z	/F		A.C ADAPTOR	AA10013040
030B			HOLDER LCD	nsp				DA600PMDF 13V 1.0A	
031B			INTRODUCER	nsp	▲ 010Z	/U		A.C ADAPTOR	AA12013020
033B			BRACKET	nsp				DA600PMDU 13V 1.0A	
037B			NUTPHONE JACK	nsp					
001F		9965 000 08880	FRAME MAIN	378V401010					
002F		9965 000 03151	BRACKET STRAP	378V160040					
011F			SHIELD CASE BOTTOM	nsp					
012F		9965 000 03152	SPRING LEAF	101C115030					
014F			INSULATOR BOTTOM SHIELD	nsp					
015F		9965 000 08884	SIDE PANEL LASSY	457S249500					
016F			SIDE PANEL L	nsp					
017F			LENS	nsp					
018F			SIDE BRACKET L	nsp					
021F		9965 000 03154	STRAP SUPPORT	378V101020					
024F			BUFFER FOR CONTACTOR	nsp					
026F		9965 000 08889	SIDE PANEL R	409S249030					
027F			SIDE BRACKET R	nsp					
039F		9965 000 03156	TAPE BATTERY EJECT	378V157010					
040F	/F		LABEL FOR 041F	nsp					
040F	/U		LABEL FOR 041F	nsp					
040F	/W		LABEL FOR 041F	nsp					
041F		9965 000 08883	BOTTOM COVER ALL	378V053430					
042F		4822 462 42119	LEG	022D057020					
044F		9965 000 03161	COVER BATTERY COVER	378V053030					
045F			SHIELD CASE UPPER	nsp					
046F			SUPPORT PCB	nsp					
047F			SUPPORT PCB COLLAR BUSH	nsp					
054F			LABEL FUSE CAUTION	nsp					
055F			LABEL FUSE CAUTION	nsp					
057F			INSULATOR SHIELD UPPER	nsp					
058F			WIRE CLAMPER	nsp					
061F			COLLAR SPACER PD01+PD02	nsp					
062F		4822 506 11003	HEXAGON NUT PD01+PD02	53110303A0					
063F			BUFFER FOR PD02	nsp					
064F			ADHESIVE FOR PQ01	nsp					
001G		9965 000 08890	TOP COVER ASSY	378V053520					
002G			TOP COVER	nsp					
003G			BUTTON A	nsp					
004G			BUTTON B	nsp					
005G			BRACKET SPEAKER	nsp				NOT STANDARD	
007G		9965 000 03176	BUSH MIC	305H056010	001S			CUSHION SET	378V809010
010G			SPACER FOR PCB	nsp	002S			CUSHION TOP	378V809020
011G		9965 000 03163	KNOB SLIDE	378V154030	003S			PACKING CASE	470S801010
012G		9965 000 08886	KNOB KEY LOCK	378V154070	010S			MASTER CARTON	470S805010

NOTE : "nsp" PART IS LISTED FOR REFERENCE ONLY, MARANTZ WILL NOT SUPPLY THESE PARTS.

8. ELECTRICAL PARTS LIST

ASSIGNMENT OF COMMON PARTS CODES.

RESISTORS

R***: 1) GD05 × × × 140, Carbon film fixed resistor, ±5% 1/4W

R***: 2) GD05 × × × 160, Carbon film fixed resistor, ±5% 1/6W

① — Resistance value

Examples ;

① Resistance value

0.1 Ω 001 10 Ω 100 1 kΩ 102 100 kΩ 104
 0.5 Ω 005 18 Ω 180 2.7 kΩ 272 680 kΩ 684
 1 Ω 010 100 Ω 101 10 kΩ 103 1 MΩ 105
 6.8 Ω 068 390 Ω 391 22 kΩ 223 4.7 MΩ 475

Note : Please distinguish 1/4W from 1/6W by the shape of parts used actually.

CAPACITORS

C***: CERAMIC CAP.

3) DD1 × × × × 370, Ceramic capacitor
 Disc type
 Temp.coeff.P350 ~ N1000, 50V
 ② — Capacity value
 ③ — Tolerance

Examples ;

② Tolerance (Capacity deviation)

±0.25 pF 0
 ±0.5 pF 1
 ±5% 5

* Tolerance of COMMON PARTS handled here are as follows :

0.5 pF ~ 5 pF ±0.25 pF
 6 pF ~ 10 pF ±0.5 pF
 12 pF ~ 560 pF ±5%

③ Capacity value

0.5 pF 005 3 pF 030 100 pF 101
 1 pF 010 10 pF 100 220 pF 221
 1.5 pF 015 47 pF 470 560 pF 561

C***: CERAMIC CAP.

4) DK16 × × × 300, High dielectric constant ceramic capacitor
 Disc type
 Temp.chara. 2B4, 50V
 ④ — Capacity value

Examples ;

④ Capacity value

100 pF 101 1000 pF 102 10000 pF 103
 470 pF 471 2200 pF 222

C***: 5) ELECTROLY CAP. (⏏), 6) FILM CAP. (⏏)

5) EA × × × × × 10, Electrolytic capacitor
 One-way lead type, Tolerance ±20%
 ⑤ — Working voltage
 ⑥ — Capacity value

Examples ;

⑤ Capacity value

0.1 μF 104 4.7 μF 475 100 μF 107
 0.33 μF 334 10 μF 106 330 μF 337
 1 μF 105 22 μF 226 1100 μF 118
 2200 μF 228

⑥ Working voltage

6.3V 006 25V 025
 10V 010 35V 035
 16V 016 50V 050

6) DF15 × × × 350 — Plastic film capacitor
 DF15 × × × 310 — One-way type, Mylar ±5% 50V
 DF16 × × × 310 — Plastic film capacitor
 One-way type, Mylar ±10% 50V
 ⑦ — Capacity value

Examples ;

⑦ Capacity value

0.001 μF (1000 pF) 102 0.1 μF 104
 0.0018 μF 182 0.56 μF 564
 0.01 μF 103 1 μF 105
 0.015 μF 153

NOTE : 1) The above CODES (R***, R***, C***, C*** and C***) are omitted on the schematic diagram in some case.

2) On the occasion, be confirmed the common parts on the parts list.

3) Refer to "Common Parts List" for the other common parts (R105, DD4, DK4).

NOTE ON SAFETY FOR FUSIBLE RESISTOR :

The suppliers and their type numbers of fusible resistors are as follows;

1. KOA Corporation

Part No. (MJI)	Type No. (KOA)	Description
NH05 × × × 140	RF25S × × × × ΩJ	(±5% 1/4W)
NH05 × × × 120	RF50S × × × × ΩJ	(±5% 1/2W)
NH85 × × × 110	RF73B2A × × × × ΩJ	(±5% 1/10W)
NH95 × × × 140	RF73B2E × × × × ΩJ	(±5% 1/4W)

* Resistance value Resistance value
 (0.1 Ω – 10 kΩ)

2. Matsushita Electronic Components Co., Ltd

Part No. (MJI)	Type No. (MEC)	Description
NF05 × × × 140	ERD-2FCJ × × ×	(±5% 1/4W)
RF05 × × × 140	ERD-2FCG × × ×	(±2% 1/4W)
NF02 × × × 140		
RF02 × × × 140		

* Resistance value * Resistance value

Examples ;

* Resistance value

0.1 Ω 001 10 Ω 100 1 kΩ 102 100 kΩ 104
 0.5 Ω 005 18 Ω 180 2.7 kΩ 272 680 kΩ 684
 1 Ω 010 100 Ω 101 10 kΩ 103 1 MΩ 105
 6.8 Ω 068 390 Ω 391 22 kΩ 223 4.7 MΩ 475

ABBREVIATION AND MARKS

ANT. : ANTENNA	BATT. : BATTERY
CAP. : CAPACITOR	CER. : CERAMIC
CONN. : CONNECTING	DIG. : DIGITAL
HP : HEADPHONE	MIC. : MICROPHONE
μ-PRO : MICROPROCESSOR	REC. : RECORDING
RES. : RESISTOR	SPK : SPEAKER
SW : SWITCH	TRANSF. : TRANSFORMER
TRIM. : TRIMMING	TRS. : TRANSISTOR
VAR. : VARIABLE	X'TAL : CRYSTAL

NOTE ON SAFETY :

Symbol ⚠ Fire or electrical shock hazard. Only original parts should be used to replaced any part marked with symbol ⚠ . Any other component substitution (other than original type), may increase risk of fire or electrical shock hazard.

安全上の注意 :

⚠ がついている部品は、安全上重要な部品です。必ず指定されている部品番号の部品を使用して下さい。

POS. NO	VERS. COLOR	PART NO. (FOR PCS)	DESCRIPTION	PART NO. (MJI)	POS. NO	VERS. COLOR	PART NO. (FOR PCS)	DESCRIPTION	PART NO. (MJI)
			PB01-BATTERY TERMINAL CIRCUIT BOARD		CN40		4822 122 33777	CER. CHIP 47pF ±0.5pF 50V	DD95470300
FB01		9965 000 03120	FUSE 2.5A 60V CCF1N2.5	FS10250940	CN41		4822 126 11687	CER. CHIP 0.1µF	DK98104200
JB01		9965 000 08895	JACK S3B-PH-SM3	YJ07018530	CN42		4822 124 41842	ELECT. CHIP 47µF 16V	EY47601620
JB02		9965 000 03122	CONTACTOR A	378V123010	CN43		4822 126 13267	CER. CHIP 330pF	DK96331300
JB03		9965 000 03122	CONTACTOR A	378V123010	CN44		4822 126 12495	CER. CHIP 1500pF	DK96152300
JB04		9965 000 03123	CONTACTOR B	378V123020	CN45		4822 126 11687	CER. CHIP 0.1µF	DK98104200
			PD01-MAIN CIRCUIT BOARD		CN46		9965 000 08925	TANTL. CHIP 22µF 25V	EY22602570
			PD01-CAPACITORS		CN47		4822 126 11687	CER. CHIP 0.1µF	DK98104200
CA52		4822 126 11687	CER. CHIP 0.1µF	DK98104200	CN48		4822 124 23002	ELECT. CHIP 10µF 16V	EY10601620
CA53		4822 126 13267	CER. CHIP 330pF	DK96331300	CN49		4822 126 11687	CER. CHIP 0.1µF	DK98104200
CC01		4822 126 11687	CER. CHIP 0.1µF	DK98104200	CP01		9965 000 08948	ELECT. 220µF 63V RJH	EF22706310
CC02		9965 000 03182	ELECT. CHIP 15µF 10V	EY15601020	CP02		4822 126 11687	CER. CHIP 0.1µF	DK98104200
CC03		4822 126 11687	CER. CHIP 0.1µF	DK98104200	CP04		4822 126 11687	CER. CHIP 0.1µF	DK98104200
CC04		4822 126 11687	CER. CHIP 0.1µF	DK98104200	CP05		4822 124 23002	ELECT. CHIP 10µF 16V	EY10601620
CC05		4822 126 11687	CER. CHIP 0.1µF	DK98104200	CP06		4822 126 11687	CER. CHIP 0.1µF	DK98104200
CC08		4822 122 33761	CER. CHIP 22pF ±5% 50V	DD95220300	CP10		5322 126 11578	CER. CHIP 1000pF ±10% 50V	DK96102300
CD01					CP11		4822 126 14249	CER. CHIP W5R 560pF	DK96561300
CD05		4822 126 11687	CER. CHIP 0.1µF	DK98104200	CP12		4822 122 31765	CER. CHIP 100pF ±5% 50V	DD95101300
CD06		4822 124 41842	ELECT. CHIP 47µF 16V	EY47601620	CP13		4822 126 11687	CER. CHIP 0.1µF	DK98104200
CD07		4822 126 11687	CER. CHIP 0.1µF	DK98104200	CP14		4822 126 11687	CER. CHIP 0.1µF	DK98104200
CD08		4822 124 41842	ELECT. CHIP 47µF 16V	EY47601620	CP15		9965 000 08950	ELECT. 100µF 10V LO IMP.	EF107010P0
CD09		4822 126 11687	CER. CHIP 0.1µF	DK98104200	CP16		9965 000 08950	ELECT. 100µF 10V LO IMP.	EF107010P0
CD11		4822 126 11687	CER. CHIP 0.1µF	DK98104200	CP17		9965 000 08951	ELECT. 47µF 35V LO IMP.	EF476035P0
CD12		9965 000 08921	TANTL. CHIP 0.1µF 20V	EY10402070	CP18		4822 126 11687	CER. CHIP 0.1µF	DK98104200
CD13		4822 126 11687	CER. CHIP 0.1µF	DK98104200	CP19		5322 126 11579	CER. CHIP 3300pF	DK96332300
CD14		4822 126 11687	CER. CHIP 0.1µF	DK98104200	CP20		9965 000 08950	ELECT. 100µF 10V LO IMP.	EF107010P0
CD15					CP21		9965 000 08952	ELECT. 33µF 35V LO IMP.	EF336035P0
CD19		4822 126 12339	CER. CHIP 2200pF	DK96222300	CP22		4822 126 11687	CER. CHIP 0.1µF	DK98104200
CL03		4822 126 11687	CER. CHIP 0.1µF	DK98104200	CP23		5322 126 11579	CER. CHIP 3300pF	DK96332300
CL07		4822 126 11687	CER. CHIP 0.1µF	DK98104200	CP24		9965 000 08953	ELECT. 100µF 25V LO IMP.	EF107025P0
CL08		9965 000 03160	ELECT. CHIP 22µF 16V	EY22601620	CP26		9965 000 08954	ELECT. 22µF 50V LO IMP.	EF226050P0
CL09		4822 126 11687	CER. CHIP 0.1µF	DK98104200	CP27		5322 126 11578	CER. CHIP 1000pF ±10% 50V	DK96102300
CL10		9965 000 03160	ELECT. CHIP 22µF 16V	EY22601620	CP28		5322 126 11578	CER. CHIP 1000pF ±10% 50V	DK96102300
CL12		4822 126 13267	CER. CHIP 330pF	DK96331300	CP29		4822 122 31765	CER. CHIP 100pF ±5% 50V	DD95101300
CL99		4822 126 13267	CER. CHIP 330pF	DK96331300	CP30		4822 126 11687	CER. CHIP 0.1µF	DK98104200
CM01		4822 122 31765	CER. CHIP 100pF ±5% 50V	DD95101300	CP31		4822 126 11687	CER. CHIP 0.1µF	DK98104200
CN05		4822 126 12339	CER. CHIP 2200pF	DK96222300	CP32		9965 000 08953	ELECT. 100µF 25V LO IMP.	EF107025P0
CN06		4822 124 23002	ELECT. CHIP 10µF 16V	EY10601620	CP33		9965 000 08953	ELECT. 100µF 25V LO IMP.	EF107025P0
CN07		9965 000 08916	ELECT. CHIP 4.7µF 25V	EY47502520	CP36		4822 124 23002	ELECT. CHIP 10µF 16V	EY10601620
CN08		4822 126 11687	CER. CHIP 0.1µF	DK98104200	CP37		4822 124 23002	ELECT. CHIP 10µF 16V	EY10601620
CN11		9965 000 03181	ELECT. CHIP 33µF 10V	EY33601020	CP38		4822 124 11229	ELECT. CHIP 4.7µF 35V	EY47503520
CN13		9965 000 08916	ELECT. CHIP 4.7µF 25V	EY47502520	CP39		4822 126 11687	CER. CHIP 0.1µF	DK98104200
CN14		9965 000 06286	CER. CHIP 470pF ±5% SL	DD95471370	CP40		9965 000 08955	ELECT. CHIP 0.1µF 50V	EY10405020
CN15		9965 000 06286	CER. CHIP 470pF ±5% SL	DD95471370	CP41		9965 000 08916	ELECT. CHIP 4.7µF 25V	EY47502520
CN18		9965 000 08916	ELECT. CHIP 4.7µF 25V	EY47502520	CP42		9965 000 08916	ELECT. CHIP 4.7µF 25V	EY47502520
CN19		9965 000 03181	ELECT. CHIP 33µF 10V	EY33601020	CP43		9965 000 00599	CER. CHIP 0.22µF ±10% 10V	DK96224200
CN20		9965 000 08915	ELECT. CHIP 10µF 25V	EY10602520	CP44		9965 000 00599	CER. CHIP 0.22µF ±10% 10V	DK96224200
CN21		4822 126 12495	CER. CHIP 1500pF	DK96152300	CP46		4822 126 13267	CER. CHIP 330pF	DK96331300
CN22		4822 126 13267	CER. CHIP 330pF	DK96331300	CP89		4822 126 13267	CER. CHIP 330pF	DK96331300
CN23		4822 126 11687	CER. CHIP 0.1µF	DK98104200	CP90		4822 126 13267	CER. CHIP 330pF	DK96331300
CN24		9965 000 08925	TANTL. CHIP 22µF 25V	EY22602570	CP91				
CN25		4822 122 33777	CER. CHIP 47pF ±0.5pF 50V	DD95470300	CP94		4822 126 11687	CER. CHIP 0.1µF	DK98104200
CN26		4822 126 11687	CER. CHIP 0.1µF	DK98104200	CP95		4822 124 41842	ELECT. CHIP 47µF 16V	EY47601620
CN27		4822 124 41842	ELECT. CHIP 47µF 16V	EY47601620	CP96		4822 124 41842	ELECT. CHIP 47µF 16V	EY47601620
CN28		9965 000 03183	ELECT. CHIP 1µF 50V	EY10505020	CP97		4822 126 11687	CER. CHIP 0.1µF	DK98104200
CN29		4822 126 11687	CER. CHIP 0.1µF	DK98104200	CP98		4822 126 11687	CER. CHIP 0.1µF	DK98104200
CN30		9965 000 03183	ELECT. CHIP 1µF 50V	EY10505020	CP99		4822 124 41842	ELECT. CHIP 47µF 16V	EY47601620
CN31		4822 126 11687	CER. CHIP 0.1µF	DK98104200	CS01		4822 124 11879	BIG ELECT. 1F 5.5V	EX10500530
CN32		4822 124 11432	ELECT. CHIP 100µF 10V	EY10701020	CS02		9965 000 03184	CER. CHIP 2pF ±0.25pF 50V	DD90020300
CN34		4822 126 11687	CER. CHIP 0.1µF	DK98104200	CS03		9965 000 03184	CER. CHIP 2pF ±0.25pF 50V	DD90020300
CN35		4822 126 11687	CER. CHIP 0.1µF	DK98104200	CS04		4822 126 11687	CER. CHIP 0.1µF	DK98104200
CN36		4822 124 23002	ELECT. CHIP 10µF 16V	EY10601620	CS05		9965 000 03160	ELECT. CHIP 22µF 16V	EY22601620
CN37		4822 126 12339	CER. CHIP 2200pF	DK96222300	CS07		4822 126 11687	CER. CHIP 0.1µF	DK98104200
CN38		4822 124 23002	ELECT. CHIP 10µF 16V	EY10601620	CS09		4822 126 11687	CER. CHIP 0.1µF	DK98104200
CN39		4822 124 11432	ELECT. CHIP 100µF 10V	EY10701020	CS13		5322 126 11583	CER. CHIP 0.01µF ±10% 25V	DK96103200
					CS14		4822 124 23002	ELECT. CHIP 10µF 16V	EY10601620
					CS15		4822 126 11687	CER. CHIP 0.1µF	DK98104200

NOTE : "nsp" PART IS LISTED FOR REFERENCE ONLY, MARANTZ WILL NOT SUPPLY THESE PARTS.

POS. NO	VERS. COLOR	PART NO. (FOR PCS)	DESCRIPTION	PART NO. (MJI)	POS. NO	VERS. COLOR	PART NO. (FOR PCS)	DESCRIPTION	PART NO. (MJI)
RN46		4822 051 30332	CHIP 3.3kΩ ±5% 1/16W	NN05332610	RS42		4822 116 82487	CHIP 0Ω ±5% 1/16W	NN05000610
RN47		4822 051 30101	CHIP 100kΩ ±5% 1/16W	NN05101610	RS43		4822 051 30103	CHIP 10kΩ ±5% 1/16W	NN05103610
RN48		4822 117 13632	CHIP 100kΩ ±5% 1/16W	NN05104610	RS48		4822 051 30101	CHIP 100kΩ ±5% 1/16W	NN05101610
RN49		4822 051 30562	CHIP 5.6kΩ ±5% 1/16W	NN05562610	RS49		4822 051 30222	CHIP 2.2kΩ ±5% 1/16W	NN05222610
RN50		4822 051 30272	CHIP 2.7kΩ ±5% 1/16W	NN05272610	RS51		4822 116 82487	CHIP 0Ω ±5% 1/16W	NN05000610
RN51		4822 051 30472	CHIP 4.7kΩ ±5% 1/16W	NN05472610	RS54		4822 116 82487	CHIP 0Ω ±5% 1/16W	NN05000610
RN52		4822 117 13632	CHIP 100kΩ ±5% 1/16W	NN05104610	RS55		4822 051 30103	CHIP 10kΩ ±5% 1/16W	NN05103610
RN53		4822 116 82487	CHIP 0Ω ±5% 1/16W	NN05000610	RS56		4822 116 82487	CHIP 0Ω ±5% 1/16W	NN05000610
					RS61		4822 051 30472	CHIP 4.7kΩ ±5% 1/16W	NN05472610
RP01		4822 117 13632	CHIP 100kΩ ±5% 1/16W	NN05104610	RS81				
RP02		9965 000 08968	CHIP 0.1Ω ±1%	NI01001110	}		4822 116 82487	CHIP 0Ω ±5% 1/16W	NN05000610
RP03		9965 000 08968	CHIP 0.1Ω ±1%	NI01001110	RS96				
RP04		4822 051 30472	CHIP 4.7kΩ ±5% 1/16W	NN05472610	RT01				
RP05		9965 000 08969	CHIP 11.0kΩ ±1%	NM11102020	}		4822 051 30103	CHIP 10kΩ ±5% 1/16W	NN05103610
RP06		9965 000 08970	CHIP 3.57kΩ ±1%	NM13571020	RT05				
RP07		4822 051 30562	CHIP 5.6kΩ ±5% 1/16W	NN05562610	RT06		4822 117 13632	CHIP 100kΩ ±5% 1/16W	NN05104610
RP08		9965 000 08971	CHIP 4.99kΩ ±1%	NM14991020	RT07		4822 051 30101	CHIP 100kΩ ±5% 1/16W	NN05101610
RP09		9965 000 08968	CHIP 0.1Ω ±1%	NI01001110	RT08		4822 116 83829	CHIP 270Ω ±5% 1/16W	NN05271610
RP10		9965 000 08968	CHIP 0.1Ω ±1%	NI01001110	RT09		4822 117 13632	CHIP 100kΩ ±5% 1/16W	NN05104610
RP11		4822 051 30332	CHIP 3.3kΩ ±5% 1/16W	NN05332610	RT11		4822 116 82487	CHIP 0Ω ±5% 1/16W	NN05000610
RP12		4822 051 30123	CHIP 12kΩ ±5% 1/16W	NN05123610	RT13		4822 116 82487	CHIP 0Ω ±5% 1/16W	NN05000610
RP13		9965 000 08970	CHIP 3.57kΩ ±1%	NM13571020	RT16		4822 116 82487	CHIP 0Ω ±5% 1/16W	NN05000610
RP17		4822 117 12891	CHIP 220kΩ ±5% 1/16W	NN05224610	RT18		4822 116 82487	CHIP 0Ω ±5% 1/16W	NN05000610
RP18		4822 117 12891	CHIP 220kΩ ±5% 1/16W	NN05224610	RU01				
RP19		4822 117 12891	CHIP 220kΩ ±5% 1/16W	NN05224610	}		4822 051 30103	CHIP 10kΩ ±5% 1/16W	NN05103610
RP20		4822 117 13632	CHIP 100kΩ ±5% 1/16W	NN05104610	RU32				
RP22		4822 117 13632	CHIP 100kΩ ±5% 1/16W	NN05104610					
RP24		9965 000 08972	CHIP 1.82kΩ ±1%	NM11821020	DC01		9965 000 03118	CHIP DIODE 1SS154	HZ20005050
RP25		9965 000 08971	CHIP 4.99kΩ ±1%	NM14991020	DC02		4822 130 81324	CHIP DIODE 1SS302	HZ20018050
RP26		4822 051 30101	CHIP 100kΩ ±5% 1/16W	NN05101610	DC03		9965 000 03117	L.E.D. LNJ210C6ARA RED	HI10085020
RP27		4822 117 12925	CHIP 47kΩ ±5% 1/16W	NN05473610	DC04		9965 000 08936	CHIP DIODE 1SS322	HZ20031050
RP28		4822 051 30681	CHIP 680Ω ±5% 1/16W	NN05681610	DC05		9965 000 03081	CHIP DIODE DAN235U	HZ20019210
RP29		4822 051 30102	CHIP 1kΩ ±5% 1/16W	NN05102610	DC06		9965 000 03081	CHIP DIODE DAN235U	HZ20019210
RP30		4822 117 13632	CHIP 100kΩ ±5% 1/16W	NN05104610	DD01		4822 130 81324	CHIP DIODE 1SS302	HZ20018050
RP31		4822 051 30103	CHIP 10kΩ ±5% 1/16W	NN05103610	DN01		4822 130 81324	CHIP DIODE 1SS302	HZ20018050
RP32		4822 051 30105	CHIP 1MΩ ±5% 1/16W	NN05105610	DN31		4822 130 81324	CHIP DIODE 1SS302	HZ20018050
RP33		4822 117 11449	CHIP 2.2kΩ ±5% 1/10W	NI05222110	DN32		4822 130 81324	CHIP DIODE 1SS302	HZ20018050
RP34		4822 117 11449	CHIP 2.2kΩ ±5% 1/10W	NI05222110	DN33		4822 130 81324	CHIP DIODE 1SS302	HZ20018050
RP41		4822 051 30105	CHIP 1MΩ ±5% 1/16W	NN05105610	▲ DP01		5322 130 10383	CHIP DIODE NSQ03A04	HZ20011100
RP94		9965 000 08973	CHIP 470Ω ±5% 1/4W	RI05471140	DP02		9965 000 06835	CHIP DIODE EC21QS03L	HZ20013100
RP95		9965 000 08973	CHIP 470Ω ±5% 1/4W	RI05471140	DP04		5322 130 10383	CHIP DIODE NSQ03A04	HZ20011100
RP96		4822 116 82487	CHIP 0Ω ±5% 1/16W	NN05000610	DP05		5322 130 10383	CHIP DIODE NSQ03A04	HZ20011100
RP98		4822 116 82487	CHIP 0Ω ±5% 1/16W	NN05000610	DP06		5322 130 10401	CHIP DIODE EC11FS2 200V 1A	HZ20012100
RP99		4822 116 82487	CHIP 0Ω ±5% 1/16W	NN05000610	DP07		9965 000 06835	CHIP DIODE EC21QS03L	HZ20013100
					DP08		9965 000 08956	CHIP DIODE U3FWJ44N	HZ20064050
RS01		4822 051 30103	CHIP 10kΩ ±5% 1/16W	NN05103610	DP09		5322 130 10383	CHIP DIODE NSQ03A04	HZ20011100
RS02		4822 051 30223	CHIP 22kΩ ±5% 1/16W	NN05223610	DP10		5322 130 10383	CHIP DIODE NSQ03A04	HZ20011100
RS03		4822 051 30223	CHIP 22kΩ ±5% 1/16W	NN05223610	DP11		5322 130 10383	CHIP DIODE NSQ03A04	HZ20011100
RS04		4822 051 30109	CHIP 10Ω ±5% 1/16W	NN05100610	DP14		4822 130 83715	CHIP DIODE 1SS301	HZ21005000
RS05		4822 051 30103	CHIP 10kΩ ±5% 1/16W	NN05103610	DP15		9965 000 08936	CHIP DIODE 1SS322	HZ20031050
RS08		4822 051 30103	CHIP 10kΩ ±5% 1/16W	NN05103610	DP16		4822 130 80522	CHIP DIODE 1SS300 DAP202U	HZ21006000
RS09		4822 051 30103	CHIP 10kΩ ±5% 1/16W	NN05103610	DP17		9965 000 06835	CHIP DIODE EC21QS03L	HZ20013100
RS10		4822 051 30103	CHIP 10kΩ ±5% 1/16W	NN05103610	DP18		4822 130 83715	CHIP DIODE 1SS301	HZ21005000
RS12		4822 051 30101	CHIP 100kΩ ±5% 1/16W	NN05101610	DP19		4822 130 80522	CHIP DIODE 1SS300	HZ21006000
RS13		4822 051 30101	CHIP 100kΩ ±5% 1/16W	NN05101610	DP20		9965 000 01743	CHIP DIODE 12V	HZ30027050
RS14		4822 051 30222	CHIP 2.2kΩ ±5% 1/16W	NN05222610	DP21		4822 130 11514	CHIP DIODE 02CZ4.7Z	HZ30017050
RS15		4822 051 30103	CHIP 10kΩ ±5% 1/16W	NN05103610	DP22		4822 130 83715	CHIP DIODE 1SS301 DAN202U	HZ21005000
RS16		4822 051 30103	CHIP 10kΩ ±5% 1/16W	NN05103610	DS01		4822 130 81324	CHIP DIODE 1SS302	HZ20018050
RS17		4822 051 30105	CHIP 1MΩ ±5% 1/16W	NN05105610	DS02		9965 000 08936	CHIP DIODE 1SS322	HZ20031050
RS19		4822 051 30123	CHIP 12kΩ ±5% 1/16W	NN05123610	DS03		9965 000 08936	CHIP DIODE 1SS322	HZ20031050
RS20		4822 051 30123	CHIP 12kΩ ±5% 1/16W	NN05123610	DS08		4822 130 81324	CHIP DIODE 1SS302	HZ20018050
RS21		4822 051 30123	CHIP 12kΩ ±5% 1/16W	NN05123610	DS09				
RS23					}		9965 000 08936	CHIP DIODE 1SS322	HZ20031050
RS32		4822 051 30103	CHIP 10kΩ ±5% 1/16W	NN05103610	DS14				
RS33		4822 051 30123	CHIP 12kΩ ±5% 1/16W	NN05123610	▲ QC01		9965 000 03131	IC AS-211D	HC10391030
RS34		4822 051 30123	CHIP 12kΩ ±5% 1/16W	NN05123610	QC02		4822 209 90266	IC NJM2904V DUAL OP.AMP	HC10173090
RS35		4822 051 30103	CHIP 10kΩ ±5% 1/16W	NN05103610	QC03		4822 209 63385	IC NJM78L05UA CHIP REG	HC90005090
RS41		4822 116 82487	CHIP 0Ω ±5% 1/16W	NN05000610	QC04		9965 000 03084	CHIP TRS. 2SA1586 GR	HX115861B0

NOTE : "nsp" PART IS LISTED FOR REFERENCE ONLY, MARANTZ WILL NOT SUPPLY THESE PARTS.

POS. NO	VERS. COLOR	PART NO. (FOR PCS)	DESCRIPTION	PART NO. (MUJ)	POS. NO	VERS. COLOR	PART NO. (FOR PCS)	DESCRIPTION	PART NO. (MUJ)
QC05		4822 130 61541	CHIP TRS. 2SC4116 GR	HX341161C0	JU02		9965 000 08899	JACK S4B-PH-SM3	YJ07018540
QC06		4822 130 61541	CHIP TRS. 2SC4116 GR	HX341161C0	JU03		9965 000 08941	PLUG KX14-20K8 0.8MM	YP07005350
QC07		9965 000 03130	TRS. 2SD1802S/T-TL	HT418022B0	LM01		9965 000 08944	EMI FILTER ACF321815-101	FM32101010
QC08		9965 000 03112	DIG.TRS. UMW1N 2	BA21001000	LP01		9965 000 08997	CHIP INDUCT.	LU80473060
QC09		9965 000 03096	DIG.TRS. DTC123JERN1105	BA21105000				D63LCB A921CY-470M	
QC10		4822 130 61541	CHIP TRS. 2SC4116GR	HX341161C0	LP02		9965 000 08998	CHIP INDUCT.	LU80473070
QC11		9965 000 08967	CHIP FET 2SK1830	HY21830000				D10F A814AY-470K	
QD01		9965 000 08922	IC MR-SHPC-01V1	HC10008980	LP03		9965 000 08958	CHIP INDUCT. 10µH D63LCB	LU80103010
QD02		9965 000 08923	IC TPS2211DB	HC10101370	LP04		9965 000 08960	CHIP INDUCT. 22µH D124C	LU80223020
QD03		9965 000 08924	IC HD74LVC08	HC700801P0	LP05		4822 157 70322	EMI FILTR1000pF+80%-20%	FM32102010
QD05		4822 209 17282	IC S80827ANUP	HC10101530	LP09		4822 157 70322	EMI FILTR 1000pF+80%-20%	FM32102010
QD06		4822 130 62662	DIG.TRS. DTC144EE	BA21104000	SC01		9965 000 03091	SLIDE SSAA12-B	SS01021070
QL01			IC XC95216-PQ160	HC10097990	ST01		9965 000 03091	SLIDE SSAA12-B	SS01021070
QN02		9965 000 08926	IC PCM3000	HC10013610	TT01		4822 142 60388	PULSE TRANS. FOR CD	TP41042010
QN03		5322 209 16563	IC NJM062V(SS0P)	HC10134090	XC01			CSTCC4.0MG	JX04006350
QN31		5322 209 16563	IC NJM062V	HC10134090	XL02			DS0-49SJ 12.288MHz	JX12001380
QN32		5322 209 16563	IC NJM062V DUAL OP.AMP	HC10134090	XS01			SMD49 16MHz	JX16002350
QN33		5322 209 16563	IC NJM062V DUAL OP.AMP	HC10134090	XS02		4822 242 10255	X-TAL CM200S	JX00002370
▲ QP01		9965 000 08961	S-875045C VOLTAGE REG.	HC10096530	XU02		4822 242 10255	X-TAL CM200S	JX00002370
▲ QP02		9965 000 08962	IC LTC1624CS8	HC10095990	XU03			SMD-49 5.000 MHz	JX05001350
QP03		9965 000 08963	CHIP FET 2SK2938S	HY22938000	065F				170S056060
▲ QP04		9965 000 08964	IC LT1375CS8	HC10096990					
▲ QP05		9965 000 08964	IC LT1375CS8	HC10096990					
▲ QP06		9965 000 08962	IC LTC1624CS8	HC10095990					
QP07		9965 000 08963	CHIP FET 2SK2938S	HY22938000					
QP09					C604		4822 124 41842	ELECT. CHIP 47µF 16V	EY47601620
↵		9965 000 08965	CHIP FET 2SK2109	HY22109000	C605		4822 126 11687	CER. CHIP 0.1µF	DK98104200
QP12					C606		4822 126 11687	CER. CHIP 0.1µF	DK98104200
QP13		9965 000 08966	CHIP FET 2SJ168	HY10168000	C607		4822 124 41842	ELECT. CHIP 47µF 16V	EY47601620
QP14		9965 000 08967	CHIP FET 2SK1830	HY21830000	C608		4822 124 41842	ELECT. CHIP 47µF 16V	EY47601620
QP15		4822 130 61425	CHIP TRS. 2SC2873 Y	HX328731B0	C609		4822 126 11687	CER. CHIP 0.1µF	DK98104200
QP16		4822 130 43954	CHIP TRS. 2SD999	HX409992A0	C610		4822 126 11687	CER. CHIP 0.1µF	DK98104200
QP17		4822 130 42734	CHIP TRS. 2SB798(DL.DK)	HX207982A0	C611		4822 124 41842	ELECT. CHIP 47µF 16V	EY47601620
QP18		9965 000 08965	CHIP FET 2SK2109	HY22109000	C612		4822 126 11687	CER. CHIP 0.1µF	DK98104200
QP19		4822 130 61425	CHIP TRS. 2SC2873 Y	HX328731B0	C613		4822 124 41842	ELECT. CHIP 47µF 16V	EY47601620
QS01		9965 000 03088	IC RS5C372A-E2	HC10036770	C614		4822 126 11687	CER. CHIP 0.1µF	DK98104200
QS02		9965 000 08235	IC AT24C04N-10SI-2.5 EEPROM	HC10033990	C615		4822 124 41842	ELECT. CHIP 47µF 16V	EY47601620
QS03		9965 000 08937	IC H8/3048 FLASH ROM (PROGRAM)	HS470SH00F	C616		4822 126 11687	CER. CHIP 0.1µF	DK98104200
QS04		9965 000 08938	IC LT1460S3-5	HC10091990	C617		4822 124 41842	ELECT. CHIP 47µF 16V	EY47601620
QS05		9965 000 08939	IC S80840ANUP	HC10102530	R604				
QS06		4822 130 62662	DIG.TRS. DTC144EE RN1104	BA21104000	↵		4822 051 30103	CHIP 10kΩ ±5% 1/16W	NN05103610
QS07		4822 130 62662	DIG.TRS. DTC144EE RN1104	BA21104000	R616				
QT01		9965 000 08927	CS8402A-CS	HC10007880	R617		4822 051 30223	CHIP 22kΩ ±5% 1/16W	NN05223610
QT02		9965 000 08224	DIG.TRS. DTC323TU	BA20080210	R618		4822 051 30223	CHIP 22kΩ ±5% 1/16W	NN05223610
QU02			IC SH7709	HC10133010	R619				
QU03		9965 000 08932	IC DRAM 4MX16BIT 4K	HC10097000					
QU04		9965 000 08932	IC DRAM 4MX16BIT 4K	HC10097000	Q602		9965 000 02201	IC TMS320C31-60	HC10100370
QU05		9965 000 08992	IC OTP 470S L SIDE (512X16)	HS470SO00F	Q604				
					↵		9965 000 08928	IC CY7C199-12VC	HC10094000
QU06		9965 000 08993	IC OTP 470S U SIDE (512X16)	HS470SO10F	Q607				
			PD01-MISCELLANEOUS		XD01			PD02-MISCELLANEOUS	
FP01		9965 000 03121	PROTECTOR POLY RXE135	FU13206050				DSO-49SJ 60MHz 5V	JX60001380
JD01		9965 000 08904	JACK CONNECTOR SCAA1A	YJ90001330					
JD02		9965 000 08905	JACK CONNECTOR SCAB1A	YJ90001320					
JL01		9965 000 08941	PLUG KX14-20K8	YP07005350					
JL02		9965 000 08942	JACK B6B-PH-SM3	YJ07019760	CF01		4822 124 41842	ELECT. CHIP 47µF 16V	EY47601620
JM01		4822 267 31174	JACK HSJ07892.5MM MINI	YJ01002440	CF02		4822 126 11687	CER. CHIP 0.1µF	DK98104200
JP01		4822 267 31619	JACK DC JACK 2A	YJ04001060	CF03		4822 126 11687	CER. CHIP 0.1µF	DK98104200
JP02		9965 000 08957	JACK B3B-PH-SM3	YJ07019730	CF04		4822 126 13909	CER. CHIP 680pF	DK96681300
JP03		9965 000 08892	JACK S5B-PH-SM3	YJ07018550	CF05		4822 126 11687	CER. CHIP 0.1µF	DK98104200
JS01		9965 000 08911	JACK IL-FPR-18S-VF-E1500	YJ0701920R	CF06		4822 126 11687	CER. CHIP 0.1µF	DK98104200
JS02		9965 000 08912	JACK IL-FPR-10S-HF-E3000	YJ07021330					
JS03		9965 000 08913	JACK B8B-PH-SM3	YJ07019780					
JS54		9965 000 08900	JACK IL-FPR-18S-HF-E3000	YJ07021400	RF01		4822 051 30392	CHIP 3.9kΩ ±5% 1/16W	NN05392610
JS55		9965 000 08914	JACK B5B-PH-SM3	YJ07019750	RF02		4822 117 12925	CHIP 47kΩ ±5% 1/16W	NN05473610
JT01		4822 290 81638	TERMINAL 14X14 RA 1L1P BL	YT02010790	RF03		4822 051 30472	CHIP 4.7kΩ ±5% 1/16W	NN05472610
					RF04		4822 051 30222	CHIP 2.2kΩ ±5% 1/16W	NN05222610

NOTE : "nsp" PART IS LISTED FOR REFERENCE ONLY, MARANTZ WILL NOT SUPPLY THESE PARTS.

POS. NO	VERS. COLOR	PART NO. (FOR PCS)	DESCRIPTION	PART NO. (MJJ)	POS. NO	VERS. COLOR	PART NO. (FOR PCS)	DESCRIPTION	PART NO. (MJJ)
RF05		4822 051 30151	CHIP 150Ω ±5% 1/16W	NN05151610	CA15		5322 122 32654	CER. CHIP 0.022μF ±10% 16V	DK96223200
RF09					CA17		4822 124 11436	TANTL. CHIP 220μF 6.3V	EY22700690
RF11		4822 051 30472	CHIP 4.7kΩ ±5% 1/16W	NN05472610	CA19		4822 126 11687	CER. CHIP 0.1μF	DK98104200
RF12		4822 051 30471	CHIP 470Ω ±5% 1/16W	NN05471610	CA20		4822 126 11687	CER. CHIP 0.1μF	DK98104200
RF13		4822 051 30103	CHIP 10kΩ ±5% 1/16W	NN05103610	CA23		9965 000 06287	CER. CHIP 0.22μF	DK98224200
RF15		4822 051 30222	CHIP 2.2kΩ ±5% 1/16W	NN05222610	CA26		9965 000 01438	ELECT. CHIP 2.2μF 50V	EY22505020
					CA27		9965 000 07028	ELECT. CHIP 470μF 10V	EY47701020
					CA28		4822 126 11687	CER. CHIP 0.1μFμF	DK98104200
			PF01-SEMICONDUCTORS		CA31		5322 126 11578	CER. CHIP 1000pF ±10% B50V	DK96102300
DF01		4822 130 83815	L.E.D. LN1371SG	HI10084020	CA32		4822 126 13396	CER. CHIP 0.047μF ±10% 16V	DK96473200
DF10					CA33		4822 126 11687	CER. CHIP 0.1μF	DK98104200
DF11		4822 130 81678	L.E.D. LED GL2PR6 RED	HI10078320	CA34		5322 122 32654	CER. CHIP 0.022μF ±10% 16V	DK96223200
					CA35		5322 126 11583	CER. CHIP 0.01μF ±10% B 25V	DK96103200
QF01		9965 000 08930	IC NJU6435FFB2	HC10207090	CA36		4822 124 11229	ELECT. CHIP 4.7μF 35V	EY47503520
QF02		9965 000 03084	CHIP TRS. 2SA1586 GR	HX115861B0	CA37		9965 000 03182	ELECT. CHIP 15μF 10V	EY15601020
QF03		9965 000 03084	CHIP TRS. 2SA1586 GR	HX115861B0	CA39		4822 126 11687	CER. CHIP 0.1μFμF	DK98104200
					CA40		4822 126 11687	CER. CHIP 0.1μFμF	DK98104200
			PF01-MISCELLANEOUS		CA41		4822 124 41842	ELECT. CHIP 47μF 16V	EY47601620
FF01		9965 000 08929	DISPLAY UNIT LCD PANEL	HQ20901800	CA42		9965 000 08918	ELECT. CHIP 22μF 10V	EY22701020
JF01		9965 000 08908	JACK IL-FPR-10S-VF	YJ07021620	CA51		9965 000 03183	ELECT. CHIP 1μF 50V	EY10505020
SF01		9965 000 08957	KEYBOARD SW. HKW0609-01-031	SK01010090	CA52		4822 122 33761	CER. CHIP 22pF ±5% CG 50V	DD95220300
SF02		9965 000 08957	KEYBOARD SW. HKW0609-01-031	SK01010090	CA53		9965 000 03160	ELECT. CHIP 22μF 16V	EY22601620
					CA54		4822 126 11687	CER. CHIP 0.1μF	DK98104200
			PH01-PHANTOM SUPPLY CIRCUIT BOARD [PMD690]		CA55		4822 126 11687	CER. CHIP 0.1μF	DK98104200
			PH01-CAPACITORS		CA56		4822 122 33761	CER. CHIP 22pF ±5% CG 50V	DD95220300
CH02		9965 000 03199	ELECT. 39μF 63V RJH	EF39606310	CA61		9965 000 03160	ELECT. CHIP 22μF 16V	EY22601620
CH03		4822 124 40756	ELECT. 1μF 100V	EA10510010	CA63		9965 000 08916	ELECT. CHIP 4.7μF 25V	EY47502520
CH04		9965 000 03199	ELECT. 39μF 63V RJH	EF39606310	CA81		9965 000 08918	ELECT. CHIP 220μF 10V	EY22701020
CH05			CER. 0.1μF +80-20% 50VDC	DD38104010	CA82		4822 124 11432	ELECT. CHIP 100μF 10V	EY10701020
CH06		9965 000 06380	ELECT. 10μF 50V	EF106050P0	CA83		4822 126 11687	CER. CHIP 0.1μF	DK98104200
					CA84		4822 126 11687	CER. CHIP 0.1μF	DK98104200
			PH01-CAPACITORS (COMMON)		CA87		4822 126 11687	CER. CHIP 0.1μF	DK98104200
C***			ELECT. ROLYTIC CAPACITOR ±20% : CH01		CA88		4822 126 11687	CER. CHIP 0.1μF	DK98104200
					CA91		4822 126 11687	CER. CHIP 0.1μF	DK98104200
			PH01-RESISTORS (COMMON)		CA94		4822 126 11687	CER. CHIP 0.1μFμF	DK98104200
R***			CARBON FILM FIXED RES. ±5% 1/6W : RH01-RH10		CA95		9965 000 08919	ELECT. CHIP 100μF 6.3V	EY10700660
					CA96		4822 126 11687	CER. CHIP 0.1μF	DK98104200
					CA98		4822 126 11687	CER. CHIP 0.1μF	DK98104200
					CA99		4822 124 41842	ELECT. CHIP 47μF 16V	EY47601620
			PH01-SEMICONDUCTORS		CG02		4822 124 23002	ELECT. CHIP 10μF 16V	EY10601620
DH01		4822 130 82859	DIODE DINL20U	HD20035290	CG03		4822 124 23002	ELECT. CHIP 10μF 16V	EY10601620
DH02		4822 130 32362	DIODE 1SS176MA165 1SS254 30V 0.1A	HD20002000	CG04		4822 124 23002	ELECT. CHIP 10μF 16V	EY10601620
DH03		4822 130 32362	DIODE 1SS176MA165 1SS254 30V 0.1A	HD20002000	CG05		4822 122 33777	CER. CHIP 47pF ±5% CG 50V	DD95470300
▲ QH01		9965 000 09000	LM2586T-ADJ	HC10050360	CG08		9965 000 08915	ELECT. CHIP 10μF 25V	EY10602520
QH02		4822 130 43233	2SC2240 GR OR BL	HT322402A0	CG09		4822 122 33777	CER. CHIP 47pF ±5% CG 50V	DD95470300
QH03		4822 130 43233	2SC2240 GR OR BL	HT322402A0	CG11		9965 000 08915	ELECT. CHIP 10μF 25V	EY10602520
					CG12		4822 124 23002	ELECT. CHIP 10μF 16V	EY10601620
					CG15		9965 000 08915	ELECT. CHIP 10μF 25V	EY10602520
					CG17		4822 122 33777	CER. CHIP 47pF ±5% CG 50V	DD95470300
			PH01-MISCELLANEOUS		CG19		9965 000 08915	ELECT. CHIP 10μF 25V	EY10602520
JH01		4822 267 30894	JACK B4B-PH-K-S	YJ06006240	CG21		9965 000 03160	ELECT. CHIP 22μF 16V	EY22601620
LH01		9965 000 08999	CHOKE COIL RCH110 151μH	LC11544500	CG22		9965 000 08915	ELECT. CHIP 10μF 25V	EY10602520
					CG23		4822 126 12495	CER. CHIP 1500pF	DK96152300
			PK01-ANALOG MAIN CIRCUIT BOARD [PMD680]		CG24		9965 000 03102	CER. CHIP 0.068μF ±10%	DK96683200
			PK01-CAPACITORS		CG25		4822 126 12061	CER. CHIP 0.1μF 25V	DK56104200
CA01		9965 000 03160	ELECT. CHIP 22μF 16V	EY22601620	CG51				
CA02		4822 126 14582	CER. CHIP 330pF ±5% CG 50V	DD95331300	}		4822 126 11687	CER. CHIP 0.1μF	DK98104200
CA03		9965 000 03160	ELECT. CHIP 22μF 16V	EY22601620	CG54				
CA04		4822 124 41842	ELECT. CHIP 47μF 16V	EY47601620	CG55		4822 051 30103	ELECT. CHIP 470μF 10V	EY47701020
CA07		9965 000 03160	ELECT. CHIP 22μF 16V	EY22601620	CG56		9965 000 07028	ELECT. CHIP 470μF 10V	EY47701020
CA08		9965 000 03160	ELECT. CHIP 22μF 16V	EY22601620	CG57		4822 126 11687	CER. CHIP 0.1μF	DK98104200
CA09		4822 122 33761	CER. CHIP 22pF ±5% CG 50V	DD95220300	CG58		4822 126 11687	CER. CHIP 0.1μF	DK98104200
CA12		9965 000 03160	ELECT. CHIP 22μF 16V	EY22601620	CG59		4822 124 41842	ELECT. CHIP 47μF 16V	EY47601620
CA13		4822 124 11432	ELECT. CHIP 100μF 10V	EY10701020	CG84		4822 124 41842	ELECT. CHIP 47μF 16V	EY47601620
					CG85		4822 124 41842	ELECT. CHIP 47μF 16V	EY47601620
					CG86		4822 126 11687	CER. CHIP 0.1μF	DK98104200
					CG87		4822 126 11687	CER. CHIP 0.1μF	DK98104200

NOTE : "nsp" PART IS LISTED FOR REFERENCE ONLY, MARANTZ WILL NOT SUPPLY THESE PARTS.

POS. NO	VERS. COLOR	PART NO. (FOR PCS)	DESCRIPTION	PART NO. (MJI)	POS. NO	VERS. COLOR	PART NO. (FOR PCS)	DESCRIPTION	PART NO. (MJI)
CG90					RA44		4822 051 30103	CHIP 10kΩ ±5% 1/16W	NN05103610
CG99		4822 126 11687	CER. CHIP 0.1μF	DK98104200	RA45		4822 051 30103	CHIP 10kΩ ±5% 1/16W	NN05103610
CK02		9965 000 03160	ELECT. CHIP 22μF 16V	EY22601620	RA50		4822 051 30222	CHIP 2.2kΩ ±5% 1/16W	NN05222610
CK05		9965 000 08915	ELECT. CHIP 10μF 25V	EY10602520	RA51		4822 117 13632	CHIP 100kΩ ±5% 1/16W	NN05104610
CK06		9965 000 03160	ELECT. CHIP 22μF 16V	EY22601620	RA52		4822 051 30103	CHIP 10kΩ ±5% 1/16W	NN05103610
CK08		9965 000 08915	ELECT. CHIP 10μF 25V	EY10602520	RA53		4822 117 13632	CHIP 100kΩ ±5% 1/16W	NN05104610
CK10		9965 000 03160	ELECT. CHIP 22μF 16V	EY22601620	RA54		4822 051 30472	CHIP 4.7kΩ ±5% 1/16W	NN05472610
CK12		9965 000 08915	ELECT. CHIP 10μF 25V	EY10602520	RA56		4822 051 30479	CHIP 47Ω ±5% 1/16W	NN05470610
CK15		9965 000 03160	ELECT. CHIP 22μF 16V	EY22601620	RA57		4822 051 30479	CHIP 47Ω ±5% 1/16W	NN05470610
CK16		9965 000 03160	ELECT. CHIP 22μF 16V	EY22601620	RA58		4822 111 91414	CHIP 1Ω ±5% 1/10W	NI05100110
CK17		4822 122 33777	CER. CHIP 47pF ±5% CG 50V	DD95470300	RA61		4822 117 13632	CHIP 100kΩ ±5% 1/16W	NN05104610
CK18		9965 000 03160	ELECT. CHIP 22μF 16V	EY22601620	RA62		4822 117 13632	CHIP 100kΩ ±5% 1/16W	NN05104610
CK19		4822 122 33777	CER. CHIP 47pF ±5% CG 50V	DD95470300	RA63		4822 117 13632	CHIP 100kΩ ±5% 1/16W	NN05104610
CK20		9965 000 03160	ELECT. CHIP 22μF 16V	EY22601620	RA64		4822 051 30101	CHIP 10Ω ±5% 1/16W	NN05101610
CK21		4822 124 11432	ELECT. CHIP 100μF 10V	EY10701020	RA65		4822 117 13632	CHIP 100kΩ ±5% 1/16W	NN05104610
CK22		9965 000 07364	ELECT. CHIP 68μF 10V	EY68601020	RA66		4822 117 13632	CHIP 100kΩ ±5% 1/16W	NN05104610
CK23		9965 000 08916	ELECT. CHIP 4.7μF 25V	EY47502520	RA69			CHIP 2.2Ω ±5% 1/8W	RI05022180
CK24		9965 000 08915	ELECT. CHIP 10μF 25V	EY10602520	RA70		4822 111 90892	CHIP 0Ω ±5% 1/10W	NI05000110
CK84		4822 126 11687	CER. CHIP 0.1μF	DK98104200	RA71		4822 117 12891	CHIP 220kΩ ±5% 1/16W	NN05224610
CK86		4822 126 11687	CER. CHIP 0.1μF	DK98104200	RA72		4822 051 30684	CHIP 68Ω ±5% 1/16W	NN05684610
CK87		4822 126 11687	CER. CHIP 0.1μF	DK98104200	RA73		4822 051 30223	CHIP 22kΩ ±5% 1/16W	NN05223610
CK90					RA74		4822 117 13632	CHIP 100kΩ ±5% 1/16W	NN05104610
CK93		4822 126 11687	CER. CHIP 0.1μF	DK98104200	RA75		4822 051 30681	CHIP 68Ω ±5% 1/16W	NN05681610
CK96		4822 126 11687	CER. CHIP 0.1μF	DK98104200	RA76		4822 117 13632	CHIP 100kΩ ±5% 1/16W	NN05104610
CK97		4822 124 41842	ELECT. CHIP 47μF 16V	EY47601620	RA78		4822 117 13632	CHIP 100kΩ ±5% 1/16W	NN05104610
CK98		4822 126 11687	CER. CHIP 0.1μF	DK98104200	RA79		4822 117 13632	CHIP 100kΩ ±5% 1/16W	NN05104610
CK99		4822 124 41842	ELECT. CHIP 47μF 16V	EY47601620	RA80		4822 117 12891	CHIP 220kΩ ±5% 1/16W	NN05224610
CY01		5322 126 11583	CER. CHIP 0.01μF ±10% B 25V	DK96103200	RA81		4822 117 13632	CHIP 100kΩ ±5% 1/16W	NN05104610
CY02		5322 126 11583	CER. CHIP 0.01μF ±10% B 25V	DK96103200	RA82		4822 116 82487	CHIP 0Ω ±5% 1/16W	NN05000610
CY03		5322 126 11583	CER. CHIP 0.01μF ±10% B 25V	DK96103200	RA83		4822 117 12902	CHIP 8.2kΩ ±5% 1/16W	NN05822610
CY04		5322 126 11583	CER. CHIP 0.01μF ±10% B 25V	DK96103200	RA84		4822 117 12891	CHIP 220kΩ ±5% 1/16W	NN05224610
CY05		4822 124 41842	ELECT. CHIP 47μF 16V	EY47601620	RA85		4822 116 83209	CHIP 120kΩ ±5% 1/16W	NN05124610
CY06		4822 126 11687	CER. CHIP 0.1μF	DK98104200	RA86		4822 051 30153	CHIP 15kΩ ±5% 1/16W	NN05153610
CY07		4822 126 11687	CER. CHIP 0.1μF	DK98104200	RA87		4822 051 30123	CHIP 12kΩ ±5% 1/16W	NN05123610
CY08		4822 122 31765	CER. CHIP 100pF ±5% CG 50V	DD95101300	RA88		4822 051 30682	CHIP 6.8kΩ ±5% 1/16W	NN05682610
			PK01-RESISTORS [PMD680]		RA89		4822 116 82487	CHIP 0Ω ±5% 1/16W	NN05000610
RA01		4822 117 13632	CHIP 100kΩ ±5% 1/16W	NN05104610	RG02		4822 117 13632	CHIP 100kΩ ±5% 1/16W	NN05104610
RA02		4822 051 30101	CHIP 10Ω ±5% 1/16W	NN05101610	RG03		4822 051 30102	CHIP 1kΩ ±5% 1/16W	NN05102610
RA03		4822 117 13632	CHIP 100kΩ ±5% 1/16W	NN05104610	RG04		4822 117 13632	CHIP 100kΩ ±5% 1/16W	NN05104610
RA04		4822 051 30472	CHIP 4.7kΩ ±5% 1/16W	NN05472610	RG05		4822 051 30392	CHIP 15kΩ ±5% 1/16W	NN05392610
RA05		4822 051 30103	CHIP 10kΩ ±5% 1/16W	NN05103610	RG06		4822 117 13632	CHIP 100kΩ ±5% 1/16W	NN05104610
RA06		4822 051 30472	CHIP 4.7kΩ ±5% 1/16W	NN05472610	RG07		4822 051 30273	CHIP 27kΩ ±5% 1/16W	NN05273610
RA07		4822 117 13632	CHIP 100kΩ ±5% 1/16W	NN05104610	RG09		4822 117 12925	CHIP 47kΩ ±5% 1/16W	NN05473610
RA10		4822 117 13632	CHIP 100kΩ ±5% 1/16W	NN05104610	RG10		4822 051 30123	CHIP 12kΩ ±5% 1/16W	NN05123610
RA12		4822 051 30223	CHIP 22kΩ ±5% 1/16W	NN05223610	RG14		4822 117 13632	CHIP 100kΩ ±5% 1/16W	NN05104610
RA13		4822 051 30393	CHIP 39kΩ ±5% 1/16W	NN05393610	RG15		4822 051 30392	CHIP 15kΩ ±5% 1/16W	NN05392610
RA14		4822 051 30392	CHIP 3.9kΩ ±5% 1/16W	NN05392610	RG17		4822 051 30333	CHIP 33kΩ ±5% 1/16W	NN05333610
RA18		4822 051 30103	CHIP 10kΩ ±5% 1/16W	NN05103610	RG19		4822 117 13632	CHIP 100kΩ ±5% 1/16W	NN05104610
RA19		4822 117 12968	CHIP 82Ω ±5% 1/16W	NN05821610	RG20		4822 117 13632	CHIP 100kΩ ±5% 1/16W	NN05104610
RA20		4822 051 30562	CHIP 5.6kΩ ±5% 1/16W	NN05562610	RG23		4822 117 12925	CHIP 47kΩ ±5% 1/16W	NN05473610
RA21		4822 051 30472	CHIP 4.7kΩ ±5% 1/16W	NN05472610	RG24		4822 051 30123	CHIP 12kΩ ±5% 1/16W	NN05123610
RA22		4822 051 30151	CHIP 15Ω ±5% 1/16W	NN05151610	RG26		4822 117 13632	CHIP 100kΩ ±5% 1/16W	NN05104610
RA24		4822 117 13632	CHIP 100kΩ ±5% 1/16W	NN05104610	RG28		4822 117 12925	CHIP 47kΩ ±5% 1/16W	NN05473610
RA26		4822 111 91414	CHIP 1Ω ±5% 1/10W	NI05100110	RG30		4822 117 13632	CHIP 100kΩ ±5% 1/16W	NN05104610
RA27		4822 051 30479	CHIP 47Ω ±5% 1/16W	NN05470610	RG31		4822 117 13632	CHIP 100kΩ ±5% 1/16W	NN05104610
RA28		4822 051 30479	CHIP 47Ω ±5% 1/16W	NN05470610	RG32		4822 117 13632	CHIP 100kΩ ±5% 1/16W	NN05104610
RA32		4822 117 13632	CHIP 100kΩ ±5% 1/16W	NN05104610	RG33		4822 051 30103	CHIP 10kΩ ±5% 1/16W	NN05103610
RA33		4822 117 12925	CHIP 47kΩ ±5% 1/16W	NN05473610	RG34		4822 051 30222	CHIP 2.2kΩ ±5% 1/16W	NN05222610
RA38		4822 051 30682	CHIP 6.8kΩ ±5% 1/16W	NN05682610	RG35		4822 051 30474	CHIP 470kΩ ±5% 1/16W	NN05474610
RA39		4822 051 30222	CHIP 2.2kΩ ±5% 1/16W	NN05222610	RG36		4822 116 83819	CHIP 18kΩ ±5% 1/16W	NN05183610
RA40			CHIP 2.2Ω ±5% 1/8W	RI05022180	RG38		4822 117 13632	CHIP 100kΩ ±5% 1/16W	NN05104610
RA41		4822 051 30103	CHIP 10kΩ ±5% 1/16W	NN05103610	RG39		4822 051 30101	CHIP 10Ω ±5% 1/16W	NN05101610
RA42		4822 051 30272	CHIP 2.7kΩ ±5% 1/16W	NN05272610	RG40		4822 117 12891	CHIP 220kΩ ±5% 1/16W	NN05224610
RA43		4822 117 13632	CHIP 100kΩ ±5% 1/16W	NN05104610	RG99		4822 051 30109	CHIP 1Ω ±5% 1/16W	NN05100610
					RK03		4822 117 13632	CHIP 100kΩ ±5% 1/16W	NN05104610

NOTE : "nsp" PART IS LISTED FOR REFERENCE ONLY, MARANTZ WILL NOT SUPPLY THESE PARTS.

POS. NO	VERS. COLOR	PART NO. (FOR PCS)	DESCRIPTION	PART NO. (MJI)	POS. NO	VERS. COLOR	PART NO. (FOR PCS)	DESCRIPTION	PART NO. (MJI)
RK09		4822 117 13632	CHIP 100kΩ ±5% 1/16W	NN05104610	RY81		4822 051 30474	CHIP 470kΩ ±5% 1/16W	NN05474610
RK10		4822 117 13632	CHIP 100kΩ ±5% 1/16W	NN05104610				PK01-SEMICONDUCTORS	
RK11		4822 051 30103	CHIP 10kΩ ±5% 1/16W	NN05103610				[PMD680]	
RK12		4822 117 13632	CHIP 100kΩ ±5% 1/16W	NN05104610	DA01		9965 000 03083	CHIP DIODE MA6S121	HZ20045020
RK13		4822 117 13632	CHIP 100kΩ ±5% 1/16W	NN05104610	DA02		9965 000 03081	CHIP DIODE DAN235U	HZ20019210
RK16		4822 117 13632	CHIP 100kΩ ±5% 1/16W	NN05104610	DA03		9965 000 03083	CHIP DIODE MA6S121	HZ20045020
RK17		4822 117 13632	CHIP 100kΩ ±5% 1/16W	NN05104610	DA04		4822 130 83715	CHIP DIODE 1SS301 DAN202U	HZ21005000
RK21		4822 051 30392	CHIP 3.9kΩ ±5% 1/16W	NN05392610	DA11		9965 000 03081	CHIP DIODE DAN235U	HZ20019210
RK22		4822 117 12925	CHIP 47kΩ ±5% 1/16W	NN05473610	DG01		9965 000 03083	CHIP DIODE MA6S121	HZ20045020
RK23		4822 051 30102	CHIP 1kΩ ±5% 1/16W	NN05102610	DK02		4822 130 81324	CHIP DIODE 1SS302	HZ20018050
RK24		4822 117 13632	CHIP 100kΩ ±5% 1/16W	NN05104610	DK03		4822 130 80522	CHIP DIODE 1SS300 DAP202U	HZ21006000
RK25		4822 051 30103	CHIP 10kΩ ±5% 1/16W	NN05103610	DK04		9965 000 03081	CHIP DIODE DAN235U	HZ20019210
RK26		4822 051 30333	CHIP 33kΩ ±5% 1/16W	NN05333610	DK05		4822 130 80522	CHIP DIODE 1SS300 DAP202U	HZ21006000
RK27		4822 051 30102	CHIP 1kΩ ±5% 1/16W	NN05102610	DK06		9965 000 03081	CHIP DIODE DAN235U	HZ20019210
RK28		4822 051 30273	CHIP 27kΩ ±5% 1/16W	NN05273610	DK07		9965 000 03081	CHIP DIODE DAN235U	HZ20019210
RK29		4822 117 12925	CHIP 47kΩ ±5% 1/16W	NN05473610	DY03		9965 000 03081	CHIP DIODE DAN235U	HZ20019210
RK30		4822 117 12902	CHIP 8.2kΩ ±5% 1/16W	NN05822610	QA01		9965 000 08917	IC BU4053BCFV	HC405321Y0
RK31		4822 051 30102	CHIP 1kΩ ±5% 1/16W	NN05102610	QA04		9965 000 03080	IC NJM2070M	HC10098090
RK32		4822 117 12925	CHIP 47kΩ ±5% 1/16W	NN05473610	QA06		9965 000 03080	IC NJM2070M	HC10098090
RK33		4822 051 30684	CHIP 68Ω ±5% 1/16W	NN05684610	QA07		5322 209 16563	IC NJM062V SS0P	HC10134090
RK34		4822 051 30102	CHIP 1kΩ ±5% 1/16W	NN05102610	QA10		9965 000 03086	DIG.TR.S. DTA114TE RN2111	BA12111000
RK35		4822 051 30103	CHIP 10kΩ ±5% 1/16W	NN05103610	QA11		9965 000 08224	DIG.TR.S. DTC323TU	BA20080210
RK37		4822 051 30472	CHIP 4.7kΩ ±5% 1/16W	NN05472610	QA13		9965 000 01658	DIG.TR.S. RN1113000	BA21113050
RK38		4822 117 12925	CHIP 47kΩ ±5% 1/16W	NN05473610	QA14		9965 000 01659	DIG.TR.S. DTC114TE RN1111	BA21111000
RK39		4822 117 13632	CHIP 100kΩ ±5% 1/16W	NN05104610	QA15		9965 000 03086	DIG.TR.S. DTA114TE RN2111	BA12111000
RK40		4822 051 30103	CHIP 10kΩ ±5% 1/16W	NN05103610	QA16		4822 130 61541	CHIP TR.S. 2SC4116 GR	HX341161C0
RK41		4822 116 82487	CHIP 0Ω ±5% 1/16W	NN05000610	QA17		9965 000 03086	DIG.TR.S. DTA114TE RN2111	BA12111000
RK42		4822 051 30472	CHIP 4.7kΩ ±5% 1/16W	NN05472610	QA18		9965 000 08224	DIG.TR.S. DTC323TU	BA20080210
RK43		4822 051 30103	CHIP 10kΩ ±5% 1/16W	NN05103610	QA19		9965 000 08224	DIG.TR.S. DTC323TU	BA20080210
RK44		4822 116 82487	CHIP 0Ω ±5% 1/16W	NN05000610	QA20		9965 000 01659	DIG.TR.S. DTC114TE RN1111	BA21111000
RK45		4822 051 30472	CHIP 4.7kΩ ±5% 1/16W	NN05472610	QA21		4822 130 61541	CHIP TR.S. 2SC4116 GR	HX341161C0
RK46		4822 116 82487	CHIP 0Ω ±5% 1/16W	NN05000610	QA22		4822 130 61425	CHIP TR.S. 2SC2873 Y	HX328731B0
RK47		4822 117 12891	CHIP 220kΩ ±5% 1/16W	NN05224610	QA23		4822 130 62662	DIG.TR.S. DTC144EE	BA21104000
RK48		4822 117 13632	CHIP 100kΩ ±5% 1/16W	NN05104610	QA24		9965 000 03086	DIG.TR.S. DTA114TE RN2111	BA12111000
RK49		4822 116 82487	CHIP 0Ω ±5% 1/16W	NN05000610	QA25		9965 000 08224	DIG.TR.S. DTC323TU	BA20080210
RK50		4822 117 13632	CHIP 100kΩ ±5% 1/16W	NN05104610	QA26		9965 000 03086	DIG.TR.S. DTA114TE RN2111	BA12111000
RK51		4822 117 13632	CHIP 100kΩ ±5% 1/16W	NN05104610	QA81		4822 130 62662	DIG.TR.S. DTC144EE RN1104	BA21104000
RK52		4822 117 13632	CHIP 100kΩ ±5% 1/16W	NN05104610	QA82		9965 000 03086	DIG.TR.S. DTA114TE RN2111	BA12111000
RK53		4822 117 13632	CHIP 100kΩ ±5% 1/16W	NN05104610	QA83		5322 209 16563	IC NJM062V SS0P	HC10134090
RK54		4822 051 30474	CHIP 470kΩ ±5% 1/16W	NN05474610	QA98		4822 130 61425	CHIP TR.S. 2SC2873 Y	HX328731B0
RK55		4822 117 13632	CHIP 100kΩ ±5% 1/16W	NN05104610	QG02		9965 000 08917	IC BU4053BCFV	HC405321Y0
RK56		4822 117 13632	CHIP 100kΩ ±5% 1/16W	NN05104610	QG03		4822 209 90575	IC NJM2068V OP-AMP	HC10168090
RK71		4822 116 82487	CHIP 0Ω ±5% 1/16W	NN05000610	QG04		4822 209 90575	IC NJM2068V OP-AMP	HC10168090
RY05		4822 117 13632	CHIP 100kΩ ±5% 1/16W	NN05104610	QG05		9965 000 08917	IC BU4053BCFV	HC405321Y0
RY06		4822 117 13632	CHIP 100kΩ ±5% 1/16W	NN05104610	QG06		4822 209 90694	IC BU4066BCFV	HC406621Y0
RY07		4822 116 82487	CHIP 0Ω ±5% 1/16W	NN05000610	QG07		9965 000 01659	DIG.TR.S. DTC114TE RN1111	BA21111000
RY08		4822 117 12925	CHIP 47kΩ ±5% 1/16W	NN05473610	QG08		9965 000 01659	DIG.TR.S. DTC114TE RN1111	BA21111000
RY09		4822 116 82487	CHIP 0Ω ±5% 1/16W	NN05000610	QG09		9965 000 03086	DIG.TR.S. DTA114TE RN2111	BA12111000
RY10		4822 116 82487	CHIP 0Ω ±5% 1/16W	NN05000610	QK02		9965 000 08917	IC BU4053BCFV	HC405321Y0
RY11		4822 117 13632	CHIP 100kΩ ±5% 1/16W	NN05104610	QK04		4822 209 90694	IC BU4066BCFV	HC406621Y0
RY12		4822 116 82487	CHIP 0Ω ±5% 1/16W	NN05000610	QK05		4822 209 90575	IC NJM2068V OP-AMP	HC10168090
RY13		4822 117 12925	CHIP 47kΩ ±5% 1/16W	NN05473610	QK06		4822 130 61541	CHIP TR.S. 2SC4116 GR	HX341161C0
RY14		4822 117 13632	CHIP 100kΩ ±5% 1/16W	NN05104610	QK07		4822 130 61541	CHIP TR.S. 2SC4116 GR	HX341161C0
RY15		4822 116 82487	CHIP 0Ω ±5% 1/16W	NN05000610	QK09		9965 000 03084	CHIP TR.S. 2SA1586 GR	HX115861B0
RY16		4822 116 82487	CHIP 0Ω ±5% 1/16W	NN05000610	QK10		9965 000 03086	DIG.TR.S. DTA114TE RN2111	BA12111000
RY17		4822 117 13632	CHIP 100kΩ ±5% 1/16W	NN05104610	QK11		9965 000 01659	DIG.TR.S. DTC114TE RN1111	BA21111000
RY18		4822 051 30474	CHIP 470kΩ ±5% 1/16W	NN05474610	QK12		9965 000 03086	DIG.TR.S. DTA114TE RN2111	BA12111000
RY19		4822 051 30474	CHIP 470kΩ ±5% 1/16W	NN05474610	QK13		9965 000 03086	DIG.TR.S. DTA114TE RN2111	BA12111000
RY51		4822 051 30103	CHIP 10kΩ ±5% 1/16W	NN05103610	QK14		9965 000 03086	DIG.TR.S. DTA114TE RN2111	BA12111000
RY52		4822 117 12891	CHIP 220kΩ ±5% 1/16W	NN05224610	QK15		9965 000 01658	DIG.TR.S. RN1113000	BA21113050
RY53		4822 117 12891	CHIP 220kΩ ±5% 1/16W	NN05224610	QK16		4822 130 62662	DIG.TR.S. DTC144EE RN1104	BA21104000
RY54		4822 117 12891	CHIP 220kΩ ±5% 1/16W	NN05224610	QK17		9965 000 03078	DIG.TR.S. DTC115EE	BA20078210
RY55		4822 117 13632	CHIP 100kΩ ±5% 1/16W	NN05104610	QK18		9965 000 01658	DIG.TR.S. RN1113000	BA21113050
RY56		4822 051 30102	CHIP 1kΩ ±5% 1/16W	NN05102610					
RY57		4822 051 30474	CHIP 470kΩ ±5% 1/16W	NN05474610					
RY58		4822 051 30683	CHIP 68kΩ ±5% 1/16W	NN05683610					
RY59		4822 117 12925	CHIP 47kΩ ±5% 1/16W	NN05473610					
RY60		4822 117 13632	CHIP 100kΩ ±5% 1/16W	NN05104610					

NOTE : *nsp* PART IS LISTED FOR REFERENCE ONLY, MARANTZ WILL NOT SUPPLY THESE PARTS.

POS. NO	VERS. COLOR	PART NO. (FOR PCS)	DESCRIPTION	PART NO. (MJI)	POS. NO	VERS. COLOR	PART NO. (FOR PCS)	DESCRIPTION	PART NO. (MJI)
			PK01-MISCELLANEOUS [PMD680]						
JA31		9965 000 08899	JACK S4B-PH-SM3-TB PH 4P	YJ07018540	CE43		9965 000 03160	ELECT. CHIP 22µF 16V	EY22601620
JA32		9965 000 08894	JACK S2B-PH-SM3	YJ07018520	CE44		9965 000 03160	ELECT. CHIP 22µF 16V	EY22601620
JA33		9965 000 08895	JACK S3B-PH-SM3	YJ07018530	CE45		9965 000 03911	TANTL. CHIP 10µF 16V	EY10601670
JA54		9965 000 08900	JACK IL-FPR-18S-HF-E3000	YJ07021400	CE46		9965 000 03911	TANTL. CHIP 10µF 16V	EY10601670
JA55		9965 000 08895	JACK S3B-PH-SM3	YJ07018530	CE47		4822 126 11687	CER. CHIP 0.1µF	DK98104200
JG03		9965 000 08892	JACK S5B-PH-SM3	YJ07018550	CE48		4822 126 11687	CER. CHIP 0.1µF	DK98104200
JG51		9965 000 08893	JACK S10B-PH-SM3	YJ07018600	CG01			ELECT. 10µF 63V	EJ10606310
JG52		9965 000 08894	JACK S2B-PH-SM3	YJ07018520	CG04				
JK01		9965 000 08895	JACK S3B-PH-SM3	YJ07018530	CG09				
JK02		9965 000 08896	JACK S6B-PH-SM3	YJ07018560	CG12		4822 126 11687	CER. CHIP 0.1µF	DK98104200
JY01		9965 000 08900	JACK IL-FPR-18S-HF-E3000	YJ07021400	CG13				
LG53		4822 157 70322	EMI FILTER NFM61R10T102 1000pF +80%-20%	FM32102010	CG16		9965 000 03160	ELECT. CHIP 22µF 16V	EY22601620
LY01		9965 000 08917	EMI FILTER NFM61R10T102 1000pF +80%-20%	FM32102010	CG17				
SY01		4822 126 11687	SLIDE SWITCH SSST01-3A	SS01021060	CG20		4822 122 33777	CER. CHIP 47pF ±5% 50V	DD95470300
SY02					CG21				
SY13		9965 000 08909	KEYBOARD SW. HKW0609-01-031	SK01010090	CG24		4822 126 11687	CER. CHIP 0.1µF	DK98104200
SY14		9965 000 08897	SLIDE SW SSSF-023-S06N1	SS02030780	CG27		4822 122 33777	CER. CHIP 47pF ±5% 50V	DD95470300
SY15		9965 000 08898	SLIDE SW. SSSF012-S06N1	SS01021050	CG28		4822 122 33777	CER. CHIP 47pF ±5% 50V	DD95470300
SY16		9965 000 08898	SLIDE SW. SSSF012-S06N1	SS01021050	CG29		4822 126 11687	CER. CHIP 0.1µF	DK98104200
SY17		9965 000 08897	SLIDE SW. SSSF-023-S06N1	SS02030780	CG30		4822 126 11687	CER. CHIP 0.1µF	DK98104200
SY18		9965 000 08978	SLIDE SW. SSSF043-S06N1	SS04030340	CG31				
SY19		9965 000 08897	SLIDE SW. SSSF-023-S06N1	SS02030780	CG34		4822 122 31765	CER. CHIP 100pF ±5% 50V	DD95101300
SY20		9965 000 08897	SLIDE SW. SSSF-023-S06N1	SS02030780	CG35				
SY21		9965 000 08898	SLIDE SW. SSSF012-S06N1	SS01021050	CG37		9965 000 01438	ELECT. CHIP 2.2µF 50V	EY22505020
SY22		9965 000 03136	SLIDE SW. SSSF022-S06N0	SS02021680	CG38		4822 126 11687	CER. CHIP 0.1µF	DK98104200
			PK01-ANALOG CIRCUIT BOARD KIT [PMD590]		CG38		4822 126 11687	CER. CHIP 0.1µF	DK98104200
			PK01-CAPACITORS		CG41				
CE01		4822 124 23002	ELECT. CHIP 10µF 16V	EY10601620	CG44		4822 124 41842	ELECT. CHIP 47µF 16V	EY47601620
CE02		4822 124 23002	ELECT. CHIP 10µF 16V	EY10601620	CK01		4822 126 13396	CER. CHIP 47pF ±10% 16V	DK96473200
CE03		4822 122 33741	CER. CHIP 10pF ±0.5pF 50V	DD91100300	CK02		4822 126 11687	CER. CHIP 0.1µF	DK98104200
CE04		4822 122 33741	CER. CHIP 10pF ±0.5pF 50V	DD91100300	CK05		4822 126 11687	CER. CHIP 0.1µF	DK98104200
CE05		4822 126 11687	CER. CHIP 0.1µF	DK98104200	CK07		4822 122 33777	CER. CHIP 47pF ±5% 50V	DD95470300
CE06		4822 126 11687	CER. CHIP 0.1µF	DK98104200	CK08		4822 122 33777	CER. CHIP 47pF ±5% 50V	DD95470300
CE07					CK09		4822 126 11687	CER. CHIP 0.1µF	DK98104200
CE10		4822 124 23002	ELECT. CHIP 10µF 16V	EY10601620	CK10		4822 126 11687	CER. CHIP 0.1µF	DK98104200
CE11		4822 126 11687	CER. CHIP 0.1µF	DK98104200	CK11		4822 124 23002	ELECT. CHIP 10µF 16V	EY10601620
CE12		4822 126 11687	CER. CHIP 0.1µF	DK98104200	CK12		4822 124 23002	ELECT. CHIP 10µF 16V	EY10601620
CE13					CK13		4822 126 13302	CER. CHIP 8200pF	DK96822200
CE16		4822 124 23002	ELECT. CHIP 10µF 16V	EY10601620	CK14		4822 126 13302	CER. CHIP 8200pF	DK96822200
CE17		4822 122 33741	CER. CHIP 10pF ±0.5pF 50V	DD91100300	CK15		4822 126 11685	CER. CHIP 4700pF ±10% 50V	DK96472300
CE18		4822 122 33741	CER. CHIP 10pF ±0.5pF 50V	DD91100300	CK16		4822 126 11685	CER. CHIP 4700pF ±10% 50V	DK96472300
CE19		4822 126 11687	CER. CHIP 0.1µF	DK98104200	CK17		4822 124 11432	ELECT. CHIP 100µF 16V	EY10701020
CE20		4822 126 11687	CER. CHIP 0.1µF	DK98104200	CK18		4822 124 11432	ELECT. CHIP 100µF 16V	EY10701020
CE21		4822 124 23002	ELECT. CHIP 10µF 16V	EY10601620	CK19		4822 124 11436	TANTL. CHIP 220µF 6.3V	EY22700690
CE22		4822 124 23002	ELECT. CHIP 10µF 16V	EY10601620	CK20		4822 124 11436	TANTL. CHIP 220µF 6.3V	EY22700690
CE25		4822 122 33741	CER. CHIP 10pF ±0.5pF 50V	DD91100300	CK21		9965 000 00599	CER. CHIP 0.22µF ±10% 10V	DK96224200
CE26		4822 122 33741	CER. CHIP 10pF ±0.5pF 50V	DD91100300	CK22		9965 000 00599	CER. CHIP 0.22µF ±10% 10V	DK96224200
CE27		4822 126 11687	CER. CHIP 0.1µF	DK98104200	CK23		4822 124 11436	TANTL. CHIP 220µF 6.3V	EY22700690
CE28		4822 126 11687	CER. CHIP 0.1µF	DK98104200	CK24		4822 124 41842	ELECT. CHIP 47µF 16V	EY47601620
CE29		4822 124 23002	ELECT. CHIP 10µF 16V	EY10601620	CK25		4822 124 11436	TANTL. CHIP 220µF 6.3V	EY22700690
CE30		4822 124 23002	ELECT. CHIP 10µF 16V	EY10601620	CK26		4822 124 11436	TANTL. CHIP 220µF 6.3V	EY22700690
CE31		4822 124 11432	ELECT. CHIP 100µF 16V	EY10701020	CK28		4822 126 12495	CER. CHIP 1500pF	DK96152300
CE32		4822 124 11432	ELECT. CHIP 100µF 16V	EY10701020	CK30		4822 124 11436	TANTL. CHIP 220µF 6.3V	EY22700690
CE33		9965 000 07364	ELECT. CHIP 68µF 10V	EY68601020	CK32		4822 126 11687	CER. CHIP 0.1µF	DK98104200
CE34		9965 000 07364	ELECT. CHIP 68µF 10V	EY68601020	CK33		4822 124 23002	ELECT. CHIP 10µF 16V	EY10601620
CE35		4822 124 23002	ELECT. CHIP 10µF 16V	EY10601620	CK34		4822 124 23002	ELECT. CHIP 10µF 16V	EY10601620
CE36					CK37		4822 126 11687	CER. CHIP 0.1µF	DK98104200
CE39		4822 126 11687	CER. CHIP 0.1µF	DK98104200	CK38		4822 126 11687	CER. CHIP 0.1µF	DK98104200
CE41		9965 000 03911	TANTL. CHIP 10µF 16V	EY10601670	CK39		4822 126 11671	CER. CHIP 33pF ±5% 50V	DD95330300
CE42		9965 000 03911	TANTL. CHIP 10µF 16V	EY10601670	CK40		4822 126 11687	CER. CHIP 0.1µF	DK98104200
					CK41		4822 126 11687	CER. CHIP 0.1µF	DK98104200
					CK42		9965 000 00599	CER. CHIP 0.22µF ±10% 10V	DK96224200
					CK43		9965 000 08919	ELECT. CHIP 100µF 6.3V/105°C	EY10700660

NOTE : "nsp" PART IS LISTED FOR REFERENCE ONLY, MARANTZ WILL NOT SUPPLY THESE PARTS.

POS. NO	VERS. COLOR	PART NO. (FOR PCS)	DESCRIPTION	PART NO. (MJI)	POS. NO	VERS. COLOR	PART NO. (FOR PCS)	DESCRIPTION	PART NO. (MJI)
CK44		4822 126 11687	CER. CHIP 0.1μF	DK98104200	C406		4822 126 11687	CER. CHIP 0.1μF	DK98104200
CK45		9965 000 07028	ELECT. CHIP 470μF 10V	EY47701020	C407		4822 124 23002	ELECT. CHIP 10μF 16V	EY10601620
CK46		4822 126 11687	CER. CHIP 0.1μF	DK98104200	C408		4822 124 23002	ELECT. CHIP 10μF 16V	EY10601620
CK47		4822 126 11687	CER. CHIP 0.1μF	DK98104200	C409		4822 126 11687	CER. CHIP 0.1μF	DK98104200
CK49		9965 000 03190	CER. CHIP 1000pF ±5% 25V	DD95102200	C410		4822 124 23002	ELECT. CHIP 10μF 16V	EY10601620
CK50		9965 000 01438	ELECT. CHIP 2.2μF 50V	EY22505020	C411		4822 122 33777	CER. CHIP 47pF ±5% 50V	DD95470300
CK51		4822 124 23002	ELECT. CHIP 10μF 16V	EY10601620	C412		4822 122 33777	CER. CHIP 47pF ±5% 50V	DD95470300
CK53		4822 124 41842	ELECT. CHIP 47μF 16V	EY47601620	C413		4822 126 11687	CER. CHIP 0.1μF	DK98104200
CK54		4822 124 41842	ELECT. CHIP 47μF 16V	EY47601620	C414		4822 126 11687	CER. CHIP 0.1μF	DK98104200
CK55		4822 126 11671	CER. CHIP 33pF ±5% 50V	DD95330300	C415				
CK56		4822 126 11671	CER. CHIP 33pF ±5% 50V	DD95330300			4822 124 23002	ELECT. CHIP 10μF 16V	EY10601620
CK57		4822 126 11687	CER. CHIP 0.1μF	DK98104200	C418				
CK58		4822 126 11687	CER. CHIP 0.1μF	DK98104200	C419		4822 126 11687	CER. CHIP 0.1μF	DK98104200
CK59		9965 000 03160	ELECT. CHIP 22μF 16V	EY22601620	C420		4822 126 11687	CER. CHIP 0.1μF	DK98104200
CK60		9965 000 03160	ELECT. CHIP 22μF 16V	EY22601620	C421		4822 124 23002	ELECT. CHIP 10μF 16V	EY10601620
CK61		4822 124 41842	ELECT. CHIP 47μF 16V	EY47601620	C422		4822 124 23002	ELECT. CHIP 10μF 16V	EY10601620
CK62		4822 126 12495	CER. CHIP 1500pF	DK96152300	C423				
CK63		9965 000 03160	ELECT. CHIP 22μF 16V	EY22601620			4822 126 11687	CER. CHIP 0.1μF	DK98104200
CK64		9965 000 03160	ELECT. CHIP 22μF 16V	EY22601620	C427				
CK65		9965 000 07028	ELECT. CHIP 470μF 10V	EY47701020					
CK66		9965 000 07028	ELECT. CHIP 470μF 10V	EY47701020					
CK67		4822 126 11687	CER. CHIP 0.1μF	DK98104200	RE01		4822 117 12925	CHIP 47kΩ ±5% 1/16W	NN05473610
CK68		4822 126 11687	CER. CHIP 0.1μF	DK98104200	RE02		4822 117 12925	CHIP 47kΩ ±5% 1/16W	NN05473610
CK69		4822 124 41842	ELECT. CHIP 47μF 16V	EY47601620	RE03		4822 051 30152	CHIP 1.5kΩ ±5% 1/16W	NN05152610
CK70		4822 126 11687	CER. CHIP 0.1μF	DK98104200	RE04		4822 051 30152	CHIP 1.5kΩ ±5% 1/16W	NN05152610
CK71					RE05		4822 051 30333	CHIP 33kΩ ±5% 1/16W	NN05333610
CK78		5322 126 11583	CER. CHIP 0.01μF ±10% 25V	DK96103200	RE06		4822 051 30333	CHIP 33kΩ ±5% 1/16W	NN05333610
CW01		4822 124 23002	ELECT. CHIP 10μF 16V	EY10601620	RE07				
CW02		4822 124 23002	ELECT. CHIP 10μF 16V	EY10601620			4822 117 13632	CHIP 100kΩ ±5% 1/16W	NN05104610
CW05		4822 122 33782	CER. CHIP 56pF	DD95560300	RE10				
CW06		4822 122 33782	CER. CHIP 56pF	DD95560300	RE11		4822 051 30392	CHIP 3.9kΩ ±5% 1/16W	NN05392610
CW07		4822 126 11687	CER. CHIP 0.1μF	DK98104200	RE12		4822 051 30392	CHIP 3.9kΩ ±5% 1/16W	NN05392610
CW08		4822 126 11687	CER. CHIP 0.1μF	DK98104200	RE13		4822 117 12925	CHIP 47kΩ ±5% 1/16W	NN05473610
CW09		4822 124 23002	ELECT. CHIP 10μF 16V	EY10601620	RE14		4822 117 12925	CHIP 47kΩ ±5% 1/16W	NN05473610
CW10		4822 124 23002	ELECT. CHIP 10μF 16V	EY10601620	RE15		4822 051 30102	CHIP 1kΩ ±5% 1/16W	NN05102610
CW11		9965 000 03160	ELECT. CHIP 22μF 16V	EY22601620	RE16		4822 051 30102	CHIP 1kΩ ±5% 1/16W	NN05102610
CW12		9965 000 03160	ELECT. CHIP 22μF 16V	EY22601620	RE17		4822 051 30103	CHIP 10kΩ ±5% 1/16W	NN05103610
CW13		4822 126 13396	CER. CHIP 47pF ±10% 16V	DK96473200	RE18		4822 051 30103	CHIP 10kΩ ±5% 1/16W	NN05103610
CW14		4822 126 13396	CER. CHIP 47pF ±10% 16V	DK96473200	RE19		4822 051 30102	CHIP 1kΩ ±5% 1/16W	NN05102610
CW15					RE20		4822 051 30102	CHIP 1kΩ ±5% 1/16W	NN05102610
CW18		4822 126 11687	CER. CHIP 0.1μF	DK98104200	RE21		4822 117 13632	CHIP 100kΩ ±5% 1/16W	NN05104610
CW19		4822 124 23002	ELECT. CHIP 10μF 16V	EY10601620	RE22		4822 117 13632	CHIP 100kΩ ±5% 1/16W	NN05104610
CW20		4822 124 23002	ELECT. CHIP 10μF 16V	EY10601620	RE23		4822 051 30103	CHIP 10kΩ ±5% 1/16W	NN05103610
CW21					RE24		4822 051 30103	CHIP 10kΩ ±5% 1/16W	NN05103610
CW22		4822 126 11687	CER. CHIP 0.1μF	DK98104200	RE25		4822 051 30102	CHIP 1kΩ ±5% 1/16W	NN05102610
CW24					RE26		4822 051 30102	CHIP 1kΩ ±5% 1/16W	NN05102610
CW25		4822 124 23002	ELECT. CHIP 10μF 16V	EY10601620	RE27		4822 051 30333	CHIP 33kΩ ±5% 1/16W	NN05333610
CW26		4822 124 23002	ELECT. CHIP 10μF 16V	EY10601620	RE28		4822 051 30333	CHIP 33kΩ ±5% 1/16W	NN05333610
CW27		4822 126 11687	CER. CHIP 0.1μF	DK98104200	RE29				
CW28		4822 126 11687	CER. CHIP 0.1μF	DK98104200			4822 117 13632	CHIP 100kΩ ±5% 1/16W	NN05104610
CW29		4822 124 41842	ELECT. CHIP 47μF 16V	EY47601620	RE42				
CW30		4822 124 41842	ELECT. CHIP 47μF 16V	EY47601620	RE43		4822 051 30103	CHIP 10kΩ ±5% 1/16W	NN05103610
CW31		4822 126 13396	CER. CHIP 47pF ±10% 16V	DK96473200	RE44		4822 116 82487	CHIP 0Ω ±5% 1/16W	NN05000610
CW32		4822 126 13396	CER. CHIP 47pF ±10% 16V	DK96473200	RE46		4822 051 30103	CHIP 10kΩ ±5% 1/16W	NN05103610
CW33		4822 126 11687	CER. CHIP 0.1μF	DK98104200	RE47		4822 051 30223	CHIP 22kΩ ±5% 1/16W	NN05223610
CW34		4822 126 11687	CER. CHIP 0.1μF	DK98104200	RE48		4822 051 30223	CHIP 22kΩ ±5% 1/16W	NN05223610
CY01					RE49		4822 117 12925	CHIP 47kΩ ±5% 1/16W	NN05473610
CY04		5322 126 11583	CER. CHIP 0.01μF ±10% 25V	DK96103200	RE50		4822 117 12925	CHIP 47kΩ ±5% 1/16W	NN05473610
CY05		4822 124 41842	ELECT. CHIP 47μF 16V	EY47601620	RE51		4822 051 30153	CHIP 15kΩ ±5% 1/16W	NN05153610
CY06		4822 126 11687	CER. CHIP 0.1μF	DK98104200	RE52		4822 051 30153	CHIP 15kΩ ±5% 1/16W	NN05153610
CY07		4822 126 11687	CER. CHIP 0.1μF	DK98104200	RE53		4822 051 30102	CHIP 1kΩ ±5% 1/16W	NN05102610
CY08		4822 122 31765	CER. CHIP 100pF ±5% 50V	DD95101300	RE54		4822 051 30102	CHIP 1kΩ ±5% 1/16W	NN05102610
C401		4822 124 23002	ELECT. CHIP 10μF 16V	EY10601620	RE55		4822 117 12925	CHIP 47kΩ ±5% 1/16W	NN05473610
C402		4822 124 23002	ELECT. CHIP 10μF 16V	EY10601620	RE56		4822 117 12925	CHIP 47kΩ ±5% 1/16W	NN05473610
C403		4822 122 31765	CER. CHIP 100pF ±5% 50V	DD95101300	RE57		4822 116 82487	CHIP 0Ω ±5% 1/16W	NN05000610
C404		4822 126 11687	CER. CHIP 0.1μF	DK98104200	RE58		4822 116 82487	CHIP 0Ω ±5% 1/16W	NN05000610
C405		4822 122 31765	CER. CHIP 100pF ±5% 50V	DD95101300	RE59		4822 117 12891	CHIP 220kΩ ±5% 1/16W	NN05224610
					RE60		4822 117 12891	CHIP 220kΩ ±5% 1/16W	NN05224610
					RE61		4822 051 30472	CHIP 4.7kΩ ±5% 1/16W	NN05472610
					RE62		4822 051 30472	CHIP 4.7kΩ ±5% 1/16W	NN05472610

NOTE : *nsp* PART IS LISTED FOR REFERENCE ONLY, MARANTZ WILL NOT SUPPLY THESE PARTS.

POS. NO	VERS. COLOR	PART NO. (FOR PCS)	DESCRIPTION	PART NO. (MJ)	POS. NO	VERS. COLOR	PART NO. (FOR PCS)	DESCRIPTION	PART NO. (MJ)
RE63		4822 117 13632	CHIP 100kΩ ±5% 1/16W	NN05104610	RG79		4822 051 30103	CHIP 10kΩ ±5% 1/16W	NN05103610
RE65		4822 051 30684	CHIP 680kΩ ±5% 1/16W	NN05684610	RG80		4822 117 13632	CHIP 100kΩ ±5% 1/16W	NN05104610
RE66		4822 051 30684	CHIP 680kΩ ±5% 1/16W	NN05684610	RG81		4822 051 30684	CHIP 680kΩ ±5% 1/16W	NN05684610
RE67		4822 051 30684	CHIP 470kΩ ±5% 1/16W	NN05684610	RG82		4822 051 30103	CHIP 10kΩ ±5% 1/16W	NN05103610
RE69					RG83				
RE72		4822 117 13632	CHIP 100kΩ ±5% 1/16W	NN05104610	RG86		4822 117 12891	CHIP 220kΩ ±5% 1/16W	NN05224610
RE73		4822 116 82487	CHIP 0Ω ±5% 1/16W	NN05000610					
RE81		4822 111 90892	CHIP 0Ω ±5% 1/10W	NI05000110	RG87		4822 117 13632	CHIP 100kΩ ±5% 1/16W	NN05104610
RE82		4822 111 90892	CHIP 0Ω ±5% 1/10W	NI05000110					
RG01		9965 000 03186	CHIP 6.8kΩ ±5% 1/2W	RI05682120	RG90				
RG02		9965 000 03186	CHIP 6.8kΩ ±5% 1/2W	RI05682120	RG91		4822 117 12891	CHIP 220kΩ ±5% 1/16W	NN05224610
RG03					RG92		4822 116 82487	CHIP 0Ω ±5% 1/16W	NN05000610
RG06		4822 117 13632	CHIP 100kΩ ±5% 1/16W	NN05104610	RG93		4822 116 82487	CHIP 0Ω ±5% 1/16W	NN05000610
RG07		9965 000 03186	CHIP 6.8kΩ ±5% 1/2W	RI05682120	RG95		4822 051 30105	CHIP 1MΩ ±5% 1/16W	NN05105610
RG08		9965 000 03186	CHIP 6.8kΩ ±5% 1/2W	RI05682120	RG96		4822 051 30105	CHIP 1MΩ ±5% 1/16W	NN05105610
RG09					RG98		4822 111 90892	CHIP 0Ω ±5% 1/10W	NI05000110
RG12		4822 117 12891	CHIP 220kΩ ±5% 1/16W	NN05224610	RK01		4822 051 30103	CHIP 10kΩ ±5% 1/16W	NN05103610
RG13					RK02		4822 051 30272	CHIP 2.7kΩ ±5% 1/16W	NN05272610
RG16		9965 000 08988	CHIP 47Ω ±5% 1/2W	RI05470120	RK03		4822 117 13632	CHIP 100kΩ ±5% 1/16W	NN05104610
RG17					RK05		4822 051 30684	CHIP 680kΩ ±5% 1/16W	NN05684610
RG20		4822 117 12891	CHIP 220kΩ ±5% 1/16W	NN05224610	RK06		4822 051 30684	CHIP 680kΩ ±5% 1/16W	NN05684610
RG21					RK07		4822 051 30223	CHIP 22kΩ ±5% 1/16W	NN05223610
RG24		4822 116 83819	CHIP 18kΩ ±5% 1/16W	NN05183610	RK08		4822 051 30223	CHIP 22kΩ ±5% 1/16W	NN05223610
RG25					RK09		4822 051 30393	CHIP 39kΩ ±5% 1/16W	NN05393610
RG28		4822 117 12891	CHIP 220kΩ ±5% 1/16W	NN05224610	RK10		4822 051 30393	CHIP 39kΩ ±5% 1/16W	NN05393610
RG29					RK11		4822 051 30153	CHIP 15kΩ ±5% 1/16W	NN05153610
RG32		4822 051 30223	CHIP 22kΩ ±5% 1/16W	NN05223610	RK12		4822 051 30153	CHIP 15kΩ ±5% 1/16W	NN05153610
RG33					RK13		4822 051 30103	CHIP 10kΩ ±5% 1/16W	NN05103610
RG36		4822 117 11449	CHIP 2.2kΩ ±5% 1/10W	NI05222110	RK14		4822 051 30103	CHIP 10kΩ ±5% 1/16W	NN05103610
RG37					RK15		4822 117 12968	CHIP 820Ω ±5% 1/16W	NN05821610
RG40		4822 117 13632	CHIP 100kΩ ±5% 1/16W	NN05104610	RK16		4822 117 12968	CHIP 820Ω ±5% 1/16W	NN05821610
RG41					RK17		4822 051 30151	CHIP 150Ω ±5% 1/16W	NN05151610
RG44		9965 000 08989	CHIP 180Ω ±5% 1/10W	NI05181110	RK18		4822 051 30151	CHIP 150Ω ±5% 1/16W	NN05151610
RG45					RK19		4822 051 30562	CHIP 5.6kΩ ±5% 1/16W	NN05562610
RG52		4822 051 30472	CHIP 4.7kΩ ±5% 1/16W	NN05472610	RK20		4822 051 30562	CHIP 5.6kΩ ±5% 1/16W	NN05562610
RG53		4822 051 30103	CHIP 10kΩ ±5% 1/16W	NN05103610	RK21		4822 117 13632	CHIP 100kΩ ±5% 1/16W	NN05104610
RG54		4822 051 30472	CHIP 4.7kΩ ±5% 1/16W	NN05472610	RK22		4822 117 13632	CHIP 100kΩ ±5% 1/16W	NN05104610
RG55		4822 117 13632	CHIP 100kΩ ±5% 1/16W	NN05104610	RK23				
RG56		4822 051 30103	CHIP 10kΩ ±5% 1/16W	NN05103610	RK26		4822 051 30479	CHIP 47Ω ±5% 1/16W	NN05470610
RG57		4822 051 30103	CHIP 10kΩ ±5% 1/16W	NN05103610	RK27		9965 000 08991	CHIP 10Ω ±5% ERJ 14	RI05100140
RG59					RK28		9965 000 08991	CHIP 10Ω ±5% ERJ 14	RI05100140
RG62		4822 117 13632	CHIP 100kΩ ±5% 1/16W	NN05104610	RK29		4822 051 30152	CHIP 1.5kΩ ±5% 1/16W	NN05152610
RG63					RK30		4822 051 30223	CHIP 22kΩ ±5% 1/16W	NN05223610
RG66		9965 000 03186	CHIP 6.8kΩ ±5% 1/2W	RI05682120	RK31		4822 051 30472	CHIP 4.7kΩ ±5% 1/16W	NN05472610
RG67		4822 051 30222	CHIP 2.2kΩ ±5% 1/16W	NN05222610	RK32		4822 117 13632	CHIP 100kΩ ±5% 1/16W	NN05104610
RG68		4822 051 30222	CHIP 2.2kΩ ±5% 1/16W	NN05222610	RK33		4822 117 13632	CHIP 100kΩ ±5% 1/16W	NN05104610
RG69		4822 051 30472	CHIP 4.7kΩ ±5% 1/16W	NN05472610	RK34		4822 117 13632	CHIP 100kΩ ±5% 1/16W	NN05104610
RG70		4822 051 30472	CHIP 4.7kΩ ±5% 1/16W	NN05472610	RK35		4822 051 30334	CHIP 1.2MΩ ±5% 1/16W	NN05125610
RG71		4822 051 30222	CHIP 2.2kΩ ±5% 1/16W	NN05222610	RK36		4822 051 30223	CHIP 22kΩ ±5% 1/16W	NN05223610
RG72		4822 051 30222	CHIP 2.2kΩ ±5% 1/16W	NN05222610	RK37		4822 051 30223	CHIP 22kΩ ±5% 1/16W	NN05223610
RG73		4822 051 30472	CHIP 4.7kΩ ±5% 1/16W	NN05472610	RK38		4822 051 30393	CHIP 39kΩ ±5% 1/16W	NN05393610
RG74		4822 051 30472	CHIP 4.7kΩ ±5% 1/16W	NN05472610	RK39		4822 051 30103	CHIP 10kΩ ±5% 1/16W	NN05103610
RG75		4822 051 30103	CHIP 10kΩ ±5% 1/16W	NN05103610	RK40		4822 051 30223	CHIP 22kΩ ±5% 1/16W	NN05223610
RG76		4822 051 30105	CHIP 1MΩ ±5% 1/16W	NN05105610	RK41		4822 117 12925	CHIP 47kΩ ±5% 1/16W	NN05473610
RG77		4822 117 13632	CHIP 100kΩ ±5% 1/16W	NN05104610	RK42		4822 117 13632	CHIP 100kΩ ±5% 1/16W	NN05104610
RG78		4822 117 13632	CHIP 100kΩ ±5% 1/16W	NN05104610	RK43		4822 051 30682	CHIP 6.8kΩ ±5% 1/16W	NN05682610
					RK44		9965 000 08991	CHIP 10Ω ±5% ERJ 14	RI05100140
					RK45		4822 051 30103	CHIP 10kΩ ±5% 1/16W	NN05103610
					RK46		4822 117 12891	CHIP 220kΩ ±5% 1/16W	NN05224610
					RK47		4822 051 30222	CHIP 2.2kΩ ±5% 1/16W	NN05222610
					RK48		4822 051 30103	CHIP 10kΩ ±5% 1/16W	NN05103610
					RK49		4822 117 13632	CHIP 100kΩ ±5% 1/16W	NN05104610
					RK50		4822 117 13632	CHIP 100kΩ ±5% 1/16W	NN05104610
					RK51		4822 117 13632	CHIP 100kΩ ±5% 1/16W	NN05104610
					RK53		4822 051 30103	CHIP 10kΩ ±5% 1/16W	NN05103610
					RK54		4822 051 30103	CHIP 10kΩ ±5% 1/16W	NN05103610
					RK55		4822 051 30223	CHIP 22kΩ ±5% 1/16W	NN05223610

NOTE : "nsp" PART IS LISTED FOR REFERENCE ONLY, MARANTZ WILL NOT SUPPLY THESE PARTS.

POS. NO	VERS. COLOR	PART NO. (FOR PCS)	DESCRIPTION	PART NO. (MJI)	POS. NO	VERS. COLOR	PART NO. (FOR PCS)	DESCRIPTION	PART NO. (MJI)
RK56		4822 051 30223	CHIP 22kΩ ±5% 1/16W	NN05223610	RY11		4822 117 13632	CHIP 100kΩ ±5% 1/16W	NN05104610
RK57		4822 051 30472	CHIP 4.7kΩ ±5% 1/16W	NN05472610	RY12		4822 116 82487	CHIP 0Ω ±5% 1/16W	NN05000610
RK58		4822 051 30472	CHIP 4.7kΩ ±5% 1/16W	NN05472610	RY13		4822 117 12925	CHIP 47kΩ ±5% 1/16W	NN05473610
RK59		4822 051 30471	CHIP 470Ω ±5% 1/16W	NN05471610	RY18		4822 051 30474	CHIP 470kΩ ±5% 1/16W	NN05474610
RK60		4822 051 30471	CHIP 470Ω ±5% 1/16W	NN05471610	RY19		4822 051 30474	CHIP 470kΩ ±5% 1/16W	NN05474610
RK61		4822 117 13632	CHIP 100kΩ ±5% 1/16W	NN05104610	R401		4822 051 30103	CHIP 10kΩ ±5% 1/16W	NN05103610
RK62		4822 117 13632	CHIP 100kΩ ±5% 1/16W	NN05104610	R402		4822 051 30103	CHIP 10kΩ ±5% 1/16W	NN05103610
RK63		4822 051 30103	CHIP 10kΩ ±5% 1/16W	NN05103610	R403		4822 051 30332	CHIP 3.3kΩ ±5% 1/16W	NN05332610
RK64		4822 051 30472	CHIP 4.7kΩ ±5% 1/16W	NN05472610	R404		4822 051 30103	CHIP 10kΩ ±5% 1/16W	NN05103610
RK65		4822 051 30472	CHIP 4.7kΩ ±5% 1/16W	NN05472610	R405		4822 051 30103	CHIP 10kΩ ±5% 1/16W	NN05103610
RK66		4822 117 13632	CHIP 100kΩ ±5% 1/16W	NN05104610	R406		4822 051 30472	CHIP 4.7kΩ ±5% 1/16W	NN05472610
RK69		4822 117 13632	CHIP 100kΩ ±5% 1/16W	NN05104610	R407		4822 051 30332	CHIP 3.3kΩ ±5% 1/16W	NN05332610
RK70		4822 117 13632	CHIP 100kΩ ±5% 1/16W	NN05104610	R408		4822 117 13632	CHIP 100kΩ ±5% 1/16W	NN05104610
RK71					R409		4822 051 30103	CHIP 10kΩ ±5% 1/16W	NN05103610
)		4822 111 90892	CHIP 0Ω ±5% 1/10W	NI05000110	R410		4822 051 30222	CHIP 2.2kΩ ±5% 1/16W	NN05222610
RK75					R411		4822 051 30109	CHIP 10Ω ±5% 1/16W	NN05100610
RK76		4822 116 82487	CHIP 0Ω ±5% 1/16W	NN05000610	R412		4822 117 13632	CHIP 100kΩ ±5% 1/16W	NN05104610
RK79		4822 116 82487	CHIP 0Ω ±5% 1/16W	NN05000610	R413		4822 051 30471	CHIP 470Ω ±5% 1/16W	NN05471610
RK80		4822 116 82487	CHIP 0Ω ±5% 1/16W	NN05000610	R414		4822 117 12925	CHIP 47kΩ ±5% 1/16W	NN05473610
RK82		9965 000 08991	CHIP 10Ω ±5% ERJ 14	RI05100140	R415		4822 117 12925	CHIP 47kΩ ±5% 1/16W	NN05473610
RK83		4822 116 82487	CHIP 0Ω ±5% 1/16W	NN05000610	R416		4822 051 30332	CHIP 3.3kΩ ±5% 1/16W	NN05332610
RK84		4822 116 82487	CHIP 0Ω ±5% 1/16W	NN05000610	R417		4822 051 30333	CHIP 33kΩ ±5% 1/16W	NN05333610
RK85		4822 117 13632	CHIP 100kΩ ±5% 1/16W	NN05104610	R418		4822 117 13632	CHIP 100kΩ ±5% 1/16W	NN05104610
RW01		4822 117 12891	CHIP 220kΩ ±5% 1/16W	NN05224610	R419		4822 117 13632	CHIP 100kΩ ±5% 1/16W	NN05104610
RW02		4822 117 12891	CHIP 220kΩ ±5% 1/16W	NN05224610	R420		4822 051 30683	CHIP 68kΩ ±5% 1/16W	NN05683610
RW03		4822 051 30153	CHIP 15kΩ ±5% 1/16W	NN05153610	R421		4822 117 13632	CHIP 100kΩ ±5% 1/16W	NN05104610
RW04		4822 051 30153	CHIP 15kΩ ±5% 1/16W	NN05153610	R422		4822 116 83819	CHIP 18kΩ ±5% 1/16W	NN05183610
RW05		4822 051 30333	CHIP 33kΩ ±5% 1/16W	NN05333610	R423		4822 117 13632	CHIP 100kΩ ±5% 1/16W	NN05104610
RW06		4822 051 30333	CHIP 33kΩ ±5% 1/16W	NN05333610	R424		4822 117 13632	CHIP 100kΩ ±5% 1/16W	NN05104610
RW07		4822 051 30101	CHIP 100Ω ±5% 1/16W	NN05101610	R425		4822 051 30223	CHIP 22kΩ ±5% 1/16W	NN05223610
RW08		4822 051 30101	CHIP 100Ω ±5% 1/16W	NN05101610	R426		4822 051 30223	CHIP 22kΩ ±5% 1/16W	NN05223610
RW09		4822 117 12891	CHIP 220kΩ ±5% 1/16W	NN05224610	R427		4822 117 12864	CHIP 82kΩ ±5% 1/16W	NN05823610
RW10		4822 117 12891	CHIP 220kΩ ±5% 1/16W	NN05224610	R428		4822 117 12864	CHIP 82kΩ ±5% 1/16W	NN05823610
RW11		4822 051 30472	CHIP 4.7kΩ ±5% 1/16W	NN05472610	R429		4822 117 12891	CHIP 220kΩ ±5% 1/16W	NN05224610
RW12		4822 051 30472	CHIP 4.7kΩ ±5% 1/16W	NN05472610	R430		4822 117 12891	CHIP 220kΩ ±5% 1/16W	NN05224610
RW13		4822 051 30222	CHIP 2.2kΩ ±5% 1/16W	NN05222610	R433				
RW14		4822 051 30222	CHIP 2.2kΩ ±5% 1/16W	NN05222610)		4822 051 30103	CHIP 10kΩ ±5% 1/16W	NN05103610
RW15		4822 051 30103	CHIP 10kΩ ±5% 1/16W	NN05103610	R438				
RW16		4822 051 30103	CHIP 10kΩ ±5% 1/16W	NN05103610	R439		4822 051 30471	CHIP 470Ω ±5% 1/16W	NN05471610
RW17		4822 117 12891	CHIP 220kΩ ±5% 1/16W	NN05224610	R440		4822 117 13632	CHIP 100kΩ ±5% 1/16W	NN05104610
RW18		4822 117 12891	CHIP 220kΩ ±5% 1/16W	NN05224610	R441		4822 051 30103	CHIP 10kΩ ±5% 1/16W	NN05103610
RW19		4822 117 13632	CHIP 100kΩ ±5% 1/16W	NN05104610	R442		4822 051 30474	CHIP 470kΩ ±5% 1/16W	NN05474610
RW20		4822 117 13632	CHIP 100kΩ ±5% 1/16W	NN05104610	R443				
RW21		4822 117 12891	CHIP 220kΩ ±5% 1/16W	NN05224610)		4822 117 13632	CHIP 100kΩ ±5% 1/16W	NN05104610
RW22		4822 117 12891	CHIP 220kΩ ±5% 1/16W	NN05224610	R447				
RW23					R448		4822 051 30105	CHIP 1MΩ ±5% 1/16W	NN05105610
)		4822 117 13632	CHIP 100kΩ ±5% 1/16W	NN05104610	R449		4822 051 30105	CHIP 1MΩ ±5% 1/16W	NN05105610
RW29					R450		4822 051 30105	CHIP 1MΩ ±5% 1/16W	NN05105610
RW30		4822 051 30103	CHIP 10kΩ ±5% 1/16W	NN05103610	R451		4822 117 12891	CHIP 220kΩ ±5% 1/16W	NN05224610
RW31		4822 051 30474	CHIP 470kΩ ±5% 1/16W	NN05474610	R452		4822 051 30103	CHIP 10kΩ ±5% 1/16W	NN05103610
RW32		4822 051 30474	CHIP 470kΩ ±5% 1/16W	NN05474610	R461		4822 051 30101	CHIP 100Ω ±5% 1/16W	NN05101610
RW33		4822 051 30474	CHIP 470kΩ ±5% 1/16W	NN05474610	R462		4822 111 90892	CHIP 0Ω ±5% 1/10W	NI05000110
RW34		4822 051 30103	CHIP 10kΩ ±5% 1/16W	NN05103610	R463		4822 051 30103	CHIP 10kΩ ±5% 1/16W	NN05103610
RW35		4822 116 82487	CHIP 0Ω ±5% 1/16W	NN05000610	R464		4822 051 30103	CHIP 10kΩ ±5% 1/16W	NN05103610
RW36		4822 051 30472	CHIP 4.7kΩ ±5% 1/16W	NN05472610	R465		4822 051 30103	CHIP 10kΩ ±5% 1/16W	NN05103610
RW37		4822 117 13632	CHIP 100kΩ ±5% 1/16W	NN05104610					
RW38		4822 051 30105	CHIP 1MΩ ±5% 1/16W	NN05105610					
RW39		4822 051 30105	CHIP 1MΩ ±5% 1/16W	NN05105610					
RW40					***			PK01-RESISTORS (COMMON)	
)		4822 117 13632	CHIP 100kΩ ±5% 1/16W	NN05104610				CARBON FILM FIXED RES.	
RW44								±5% 1/6W : RK91	
RW45		4822 116 82487	CHIP 0Ω ±5% 1/16W	NN05000610				PK01-SEMICONDUCTORS	
RW46		4822 051 30103	CHIP 10kΩ ±5% 1/16W	NN05103610				[PMD690]	
RW47		4822 117 13632	CHIP 100kΩ ±5% 1/16W	NN05104610	DE03		4822 130 81324	CHIP DIODE 1SS302	HZ20018050
RY05		4822 117 13632	CHIP 100kΩ ±5% 1/16W	NN05104610	DE04		4822 130 81324	CHIP DIODE 1SS302	HZ20018050
RY06		4822 117 13632	CHIP 100kΩ ±5% 1/16W	NN05104610	DE05		4822 130 80522	CHIP DIODE 1SS300	HZ21006000
RY07		4822 116 82487	CHIP 0Ω ±5% 1/16W	NN05000610	DE06		4822 130 80522	CHIP DIODE 1SS300	HZ21006000
RY08		4822 117 12925	CHIP 47kΩ ±5% 1/16W	NN05473610	DE07		9965 000 03081	CHIP DIODE DAN235U	HZ20019210
RY09		4822 116 82487	CHIP 0Ω ±5% 1/16W	NN05000610	DE08		4822 130 81324	CHIP DIODE 1SS302	HZ20018050
RY10		4822 116 82487	CHIP 0Ω ±5% 1/16W	NN05000610					

NOTE : *nsp* PART IS LISTED FOR REFERENCE ONLY, MARANTZ WILL NOT SUPPLY THESE PARTS.

POS. NO	VERS. COLOR	PART NO. (FOR PCS)	DESCRIPTION	PART NO. (MJ)	POS. NO	VERS. COLOR	PART NO. (FOR PCS)	DESCRIPTION	PART NO. (MJ)
DG01		4822 130 11514	CHIP DIODE 02CZ4.7Z	HZ30017050	QK05		5322 209 16563	IC NJM062V DUAL OP.AMP	HC10134090
DG08					QK07		9965 000 08224	DIG.TRS. DTC323TU	BA20080210
DG09		9965 000 03082	CHIP DIODE 30V 0.03A 1V	HZ20043020	QK08		9965 000 08224	DIG.TRS. DTC323TU	BA20080210
DG10		9965 000 03082	CHIP DIODE 30V 0.03A 1V	HZ20043020	QK09		9965 000 08990	CHIP TRS. 2SD1950 VL	HX419501A0
DG11		9965 000 01743	CHIP DIODE 12V	HZ30027050	QK10		9965 000 08990	CHIP TRS. 2SD1950 VL	HX419501A0
DG12		9965 000 01743	CHIP DIODE 12V	HZ30027050	QK12		4822 130 61541	CHIP TRS. 2SC4116GR	HX341161C0
DG13		9965 000 03082	CHIP DIODE 30V 0.03A 1V	HZ20043020	QK13		9965 000 03086	DIG.TRS. RN2111DTA114TE	BA12111000
DG14		9965 000 03082	CHIP DIODE 30V 0.03A 1V	HZ20043020	QK14		9965 000 03079	IC TC74HC4052AFT	HC705205Y0
DG15		9965 000 03081	CHIP DIODE DAN235U	HZ20019210	QK15		9965 000 03080	IC NJM2070M	HC10098090
DG16		9965 000 03081	CHIP DIODE DAN235U	HZ20019210	QK16		9965 000 03086	DIG.TRS. RN2111DTA114TE	BA12111000
DG17		9965 000 03081	CHIP DIODE DAN235U	HZ20019210	QK17		9965 000 08224	DIG.TRS. DTC323TU	BA20080210
DK01		9965 000 03081	CHIP DIODE DAN235U	HZ20019210	QK19		9965 000 01659	DIG.TRS. DTC114TERN1111	BA21111000
DK02		4822 130 81324	CHIP DIODE 1SS302	HZ20018050	QK21		9965 000 03086	DIG.TRS. RN2111DTA114TE	BA12111000
DK03		9965 000 03081	CHIP DIODE DAN235U	HZ20019210	QK22		9965 000 03086	DIG.TRS. RN2111DTA114TE	BA12111000
DK04		9965 000 03083	CHIP DIODE MA6S121	HZ20045020	QK23				
DK05		9965 000 03083	CHIP DIODE MA6S121	HZ20045020			9965 000 08224	DIG.TRS. DTC323TU	BA20080210
DW01		9965 000 03083	CHIP DIODE MA6S121	HZ20045020	QK28				
DW02		9965 000 03081	CHIP DIODE DAN235U	HZ20019210	QK31		4822 130 61541	CHIP TRS. 2SC4116GR	HX341161C0
D401		9965 000 03081	CHIP DIODE DAN235U	HZ20019210	QW01		4822 209 17155	IC NJM2068M	HC10102090
D403		9965 000 03083	CHIP DIODE MA6S121	HZ20045020	QW02		9965 000 03079	IC TC74HC4052AFT	HC705205Y0
QE01		4822 209 17155	NJM2068M	HC10102090	QW03		4822 209 90694	IC BU4066BCFV	HC406621Y0
QE02		9965 000 08917	BU4053BCFV	HC405321Y0	QW04		4822 209 90694	IC BU4066BCFV	HC406621Y0
QE03		9965 000 08917	BU4053BCFV	HC405321Y0	QW05		4822 209 90575	IC NJM2068V OP-AMP	HC10168090
QE04		4822 209 90575	NJM2068V OP-AMP	HC10168090	QW06		4822 130 62662	DIG.TRS. DTC144EE RN1104	BA21104000
QE05					QW07		4822 130 62662	DIG.TRS. DTC144EE RN1104	BA21104000
		4822 130 61541	CHIP TRS. 2SC4116GR	HX341161C0	QW08		4822 130 62662	DIG.TRS. DTC144EE RN1104	BA21104000
QE08					QW09		9965 000 03086	DIG.TRS. RN2111DTA114TE	BA12111000
QE13		9965 000 01658	DIG.TRS. RN1113DTC144TE	BA21113050	QW10		4822 130 61541	CHIP TRS. 2SC4116GR	HX341161C0
QE14		5322 209 16563	IC NJM062V DUAL OP.AMP	HC10134090	QW11		4822 130 62662	DIG.TRS. DTC144EE RN1104	BA21104000
QE15					QW12		4822 209 31421	IC TC4W53F	HC10333050
		9965 000 01659	DIG.TRS. DTC114TERN1111	BA21111000	Q401		5322 209 16563	IC NJM062V DUAL OP.AMP	HC10134090
QE18					Q404		4822 209 90575	IC NJM062V DUAL OP.AMP	HC10168090
QE20		9965 000 03084	CHIP TRS. 2SA1586 GR	HX115861B0	Q405		9965 000 03079	IC TC74HC4052AFT	HC705205Y0
QE21		9965 000 03086	DIG.TRS. RN2111DTA114TE	BA12111000	Q406		9965 000 03079	IC TC74HC4052AFT	HC705205Y0
QE22		4822 209 90575	IC NJM2068V OP-AMP	HC10168090	Q408		9965 000 01658	DIG.TRS. RN1113DTC144TE	BA21113050
QG01					Q409		4822 130 61541	CHIP TRS. 2SC4116GR	HX341161C0
		9965 000 08984	CHIP FET 2SK1062-L	HY210620A0	Q410		4822 130 61541	CHIP TRS. 2SC4116GR	HX341161C0
QG04					Q411		4822 130 61541	CHIP TRS. 2SC4116GR	HX341161C0
QG05		9965 000 03079	IC TC74HC4052AFT	HC705205Y0	Q412		9965 000 01658	DIG.TRS. RN1113DTC144TE	BA21113050
QG06		9965 000 03079	IC TC74HC4052AFT	HC705205Y0	Q413		9965 000 03084	CHIP TRS. 2SA1586GR	HX115861B0
QG07		4822 209 17155	IC NJM2068M	HC10102090	Q414		4822 130 61541	CHIP TRS. 2SC4116GR	HX341161C0
QG08		4822 209 17155	IC NJM2068M	HC10102090	Q415		9965 000 01658	DIG.TRS. DTC144TERN1113	BA21113050
QG09									
		9965 000 01659	DIG.TRS. DTC114TERN1111	BA21111000					
QG12									
QG13		4822 209 90575	IC NJM2068V OP-AMP	HC10168090					
QG14		9965 000 01657	DIG.TRS. RN2113DTA144TE	BA12113000	JE01		9965 000 08892	JACK S5B-PH-SM3-TB JST	YJ07018550
QG15		9965 000 01658	DIG.TRS. RN1113DTC144TE	BA21113050	JG01		9965 000 08896	JACK S6B-PH-SM3-TB	YJ07018560
QG16		4822 130 62597	DIG.TRS. RN2102DTA114EEA	BA12102000	JG02		9965 000 08899	JACK S4B-PH-SM3	YJ07018540
QG17		9965 000 03084	CHIP TRS. 2SA1586 GR	HX115861B0	JG03		9965 000 08899	JACK S4B-PH-SM3	YJ07018540
QG18		4822 130 62662	DIG.TRS. DTC144EE RN1104	BA21104000	JK01		9965 000 08892	JACK S5B-PH-SM3-TB JST	YJ07018550
QG19					JK02		9965 000 08892	JACK S5B-PH-SM3-TB JST	YJ07018550
		9965 000 08966	CHIP FET 2SJ168	HY10168000	JK03		9965 000 08900	JACK IL-FPR-18S-HF-E3000	YJ07021400
QG22					JK04		9965 000 08899	JACK S4B-PH-SM3	YJ07018540
QG23					JK05		9965 000 08894	JACK S2B-PH-SM3	YJ07018520
		9965 000 01659	DIG.TRS. DTC114TERN1111	BA21111000	JK06		9965 000 08957	JACK B3B-PH-SM3-TB	YJ07019730
QG26					JK07		9965 000 08892	JACK S5B-PH-SM3-TB JST	YJ07018550
QG27		9965 000 03086	DIG.TRS. RN2111DTA114TE	BA12111000	JY01		9965 000 08900	JACK IL-FPR-18S-HF-E3000	YJ07021400
QG28		9965 000 01658	DIG.TRS. RN1113DTC144TE	BA21113050	J401		9965 000 08894	JACK S2B-PH-SM3	YJ07018520
QG29		4822 130 62662	DIG.TRS. DTC144EE /RN1104	BA21104000	LK01		4822 157 70322	EMI FILTR 1000pF+80%-20%	FM32102010
QG30		9965 000 03084	CHIP TRS. 2SA1586 GR	HX115861B0	LK03		9965 000 08944	EMI FILTER ACF321815-101	FM32101010
QG31		9965 000 01658	DIG.TRS. RN1113DTC144TE	BA21113050	LK04		9965 000 08944	EMI FILTER ACF321825-101	FM32101010
QG33					LY01		4822 157 70322	EMI FILTR 1000pF+80%-20%	FM32102010
		9965 000 08984	CHIP FET 2SK1062-L	HY210620A0	SE01		9965 000 08897	SLIDE SSSF-023-S06N1	SS02030780
QG35		9965 000 08984	CHIP FET 2SK1062-L	HY210620A0	SG01		9965 000 03136	SLIDE SSSF022-S06N0	SS02021680
QK01		9965 000 01659	DIG.TRS. DTC114TERN1111	BA21111000	SK01		9965 000 08897	SLIDE SSSF-023-S06N1	SS02030780
QK02		5322 209 16563	IC NJM062V DUAL OP.AMP	HC10134090	SW01		9965 000 08897	SLIDE SSSF-023-S06N1	SS02030780
QK03		5322 209 16563	IC NJM062V DUAL OP.AMP	HC10134090	SY01		9965 000 03100	SLIDE SSST01-3A	SS01021060
QK04		5322 209 61872	IC NJM2073M	HC10067090					

NOTE : "nsp" PART IS LISTED FOR REFERENCE ONLY, MARANTZ WILL NOT SUPPLY THESE PARTS.

POS. NO	VERS. COLOR	PART NO. (FOR PCS)	DESCRIPTION	PART NO. (MJI)	POS. NO	VERS. COLOR	PART NO. (FOR PCS)	DESCRIPTION	PART NO. (MJI)
SY02		9965 000 08957	KEYBOARD SW.	SK01010090	CW13		9965 000 03160	ELECT. CHIP 22µF 16V	EY22601620
SY13			HKW0609-01-031		CW14		9965 000 06286	CER. CHIP 470pF ±5% J SL	DD95471370
SY15		9965 000 08898	SLIDE SSSF012-S06N1	SS01021050	CW21		4822 126 12495	CER. CHIP 1500pF	DK96152300
SY16		9965 000 08898	SLIDE SSSF012-S06N1	SS01021050	CW31		4822 124 41842	ELECT. CHIP 47µF 16V	EY47601620
SY20		9965 000 08897	SLIDE SSSF-023-S06N1	SS02030780	CW32		4822 124 41842	ELECT. CHIP 47µF 16V	EY47601620
S401		9965 000 08897	SLIDE SSSF-023-S06N1	SS02030780	CW33		4822 126 11687	CER. CHIP 0.1µF	DK98104200
S402		9965 000 08897	SLIDE SSSF-023-S06N1	SS02030780	CW34		4822 126 11687	CER. CHIP 0.1µF	DK98104200
			PK02-PHANTOM SW CIRCUIT BOARD [PMD690]		CW35		4822 126 11687	CER. CHIP 0.1µF	DK98104200
CV21		4822 122 30043	CER. 0.01µF +80%-20% 50V	DK18103310	CW36		4822 126 11687	CER. CHIP 0.1µF	DK98104200
JV21		4822 267 30894	JACK B4B-PH-K-S	YJ06006240	CW37		4822 126 11687	CER. CHIP 0.1µF	DK98104200
SV21		9965 000 03141	SLIDE PHANTOM SW SSAA22-B NON-SHORT	SS02021710	CW38		4822 126 11687	CER. CHIP 0.1µF	DK98104200
			PK31-HEADPHONE JACK CIRCUIT BOARD		CW39		4822 126 13956	CER. CHIP 68PF	DD95680300
			PK31-CAPACITORS		CW40		4822 126 11687	CER. CHIP 0.1µF	DK98104200
CK52		4822 126 12495	CER. CHIP 1500pF	DK96152300	CW41		4822 126 11687	CER. CHIP 0.1µF	DK98104200
CK53		4822 124 41842	CER. CHIP 1500pF	DK96152300					
CK54		4822 124 41842	CER. CHIP 1500pF	DK96152300					
			PK31-MISCELLANEOUS		RW01		4822 117 13632	CHIP 100kΩ ±5% 1/16W	NN05104610
JK32		9965 000 08901	JACK B4B-PH-SM3-TB JST	YJ07019740	RW02		4822 051 30392	CHIP 3.9kΩ ±5% 1/16W	NN05392610
JK33		9965 000 03138	JACK HLJ5305-01-4170	YJ01004540	RW03		4822 116 83819	CHIP 18kΩ ±5% 1/16W	NN05183610
			PQ01- +5V DC-DC CONV. CIRCUIT BOARD [PMD690]		RW04		4822 051 30472	CHIP 4.7kΩ ±5% 1/16W	NN05472610
			PQ01-CAPASITORS		RW05		4822 051 30123	CHIP 12kΩ ±5% 1/16W	NN05123610
CQ01		9965 000 03160	ELECT. CHIP 22µF 16V	EY22601620	RW11		4822 051 30101	CHIP 10Ω ±5% 1/16W	NN05101610
CQ02		4822 122 31765	CER. CHIP 100pF ±5% 50V	DD95101300	RW12		4822 051 30682	CHIP 6.8kΩ ±5% 1/16W	NN05682610
CQ03		4822 124 11436	TANTL. CHIP 220µF 6.3V	EY22700690	RW14		4822 117 13632	CHIP 100kΩ ±5% 1/16W	NN05104610
CQ04		4822 124 11436	TANTL. CHIP 220µF 6.3V	EY22700690	RW15		4822 051 30101	CHIP 10Ω ±5% 1/16W	NN05101610
			PQ01-RESISTORS		RW21		4822 117 13632	CHIP 100kΩ ±5% 1/16W	NN05104610
RQ01		4822 117 12891	CHIP 220kΩ ±5% 1/16W	NN05224610	RW22		4822 117 11817	CHIP 1.2kΩ ±5% 1/16W	NN05122610
RQ02		4822 117 12891	CHIP 220kΩ ±5% 1/16W	NN05224610	RW24		4822 051 30223	CHIP 22kΩ ±5% 1/16W	NN05223610
RQ03		9965 000 09003	CHIP 560kΩ ±5% 1/16W	NN05564610	RW25		4822 051 30103	CHIP 10kΩ ±5% 1/16W	NN05103610
			PQ01-SEMICONDUCTORS		RW27		4822 116 82487	CHIP 0Ω ±5% 1/16W	NN05000610
DQ01		4822 130 83718	CHIP DIODE EC15QS02L (MINI POWER 1.3A)	HZ20006100	RW43		4822 051 30471	CHIP 47Ω ±5% 1/16W	NN05471610
QQ01		9965 000 09002	IC S-8521D33MC-BXS	HC10106530					
QQ02		4822 130 63611	CHIP FET 2SJ238	HY10238000					
			PQ01-MISCELLANEOUS		QW01		5322 209 16563	IC NJM062V SS0P	HC10134090
JQ01		9965 000 08895	JACK S2B-PH-SM3-TB	YJ07018530	QW02		5322 209 16563	IC NJM062V DUAL OP.AMP	HC10134090
LQ01		9965 000 09001	CHIP INDUCT. D10F A814AY-681K	LU80684010	QW21		9965 000 03086	DIG.TR.S. DTA114TE RN2111	BA12111000
WQ01			JQ01-PD01 WIRE AWG28	YB00142320	QW22		9965 000 08224	DIG.TR.S. DTC323TU	BA20080210
			PV01- HP/SP VR CIRCUIT BOARD [PMD690]						
			PV01-MISCELLANEOUS		JW01		4822 265 31044	TERMINAL 2P RCA PIN JACK BLK YKC21-3079	YT02021070
JV31			JACK S5B-PH-K-S	YJ06006450	JW02		9965 000 08942	JACK B6B-PH-SM3	YJ07019760
RV31		9965 000 03140	VAR. SP/HP VR 10K A	RM01031130	LW01		9965 000 08944	EMI FILTER ACF321815-101	FM32101010
			PV91-HEADPHONE VOLUME CIRCUIT BOARD [PMD680]						
JV91		4822 124 11432	JACK S3B-PH-SM3	YJ07018530					
RV91		4822 267 31619	VRE. RES. HP/SP RK097110	RK01031520					
			PW01-LINE IN/OUT CIRCUIT BOARD [PMD680]						
			PW01-CAPACITORS		CV11		4822 122 40617	CER. 0.1µF +80-20% 50VDC	DD38104010
CW01		9965 000 06286	CER. CHIP 470pF ±5% J SL	DD95471370	CV12		4822 122 40617	CER. 0.1µF +80-20% 50VDC	DD38104010
CW02		4822 124 23002	ELECT. CHIP 10µF 16V	EY10601620					
CW04		9965 000 03160	ELECT. CHIP 22µF 16V	EY22601620					
CW12		9965 000 03160	ELECT. CHIP 22µF 16V	EY22601620					
			PW01-RESISTORS						
			PW01-MISCELLANEOUS						
			PW01-CAPACITORS (COMMON)						
			HIGH DIELECT.RIC CONSTANT CER. CAPACITOR ±10% 50V : CV13 CV14						
			PW01-RESISTORS						
			0Ω ±5% 1/16W	GD05000160					
			0Ω ±5% 1/16W	GD05000160					
			PW01-MISCELLANEOUS						
			TERMINAL 1P RCA WHITE	YT02011260					
			TERMINAL 1P RCA RED	YT02011270					
			JACK B3B-PH-K-S	YJ06006230					
			PW02-MIC INPUT CIRCUIT BOARD [PMD680]						
			PW02-CAPACITORS						
			TANTL. CHIP 10µF 16V	EY10601670					
			TANTL. CHIP 10µF 16V	EY10601670					

NOTE : *nsp* PART IS LISTED FOR REFERENCE ONLY, MARANTZ WILL NOT SUPPLY THESE PARTS.

POS. NO	VERS. COLOR	PART NO. (FOR PCS)	DESCRIPTION	PART NO. (MJI)	POS. NO	VERS. COLOR	PART NO. (FOR PCS)	DESCRIPTION	PART NO. (MJI)
C403		4822 122 31765	CER. CHIP 100pF ±5% CG 50V	DD95101300	L404		4822 157 70322	EMI FILTER NFM61R10T102 1000pF +80%-20%	FM32102010
C404		4822 122 31765	CER. CHIP 100pF ±5% CG 50V	DD95101300					
C405		4822 122 33777	CER. CHIP 47pF ±5% CG 50V	DD95470300					
C406		4822 122 33777	CER. CHIP 47pF ±5% CG 50V	DD95470300					
C407		4822 124 12198	ELECT. CHIP 33µF 25V	EY33602520					
C408		4822 124 12198	ELECT. CHIP 33µF 25V	EY33602520					
C411		9965 000 08945	TANTL. CHIP 10µF 25V	EY10602570	CV01		4822 122 40617	CER. 0.1µF +80-20% 50VDC	DD38104010
C412		9965 000 08945	TANTL. CHIP 10µF 25V	EY10602570	CV02		4822 122 40617	CER. 0.1µF +80-20% 50VDC	DD38104010
C413		4822 122 33753	CER. CHIP 150pF ±5% CG 50V	DD95151300					
C414		9965 000 08945	TANTL. CHIP 10µF 25V	EY10602570					
C431		4822 122 31765	CER. CHIP 100pF ±5% CG 50V	DD95101300	RV01				
C432		9965 000 03911	TANTL. CHIP 10µF 16V	EY10601670	}				
C433		4822 122 33777	CER. CHIP 47pF ±5% CG 50V	DD95470300	RV04			0Ω ±5% 1/16W	GD05000160
C434		4822 124 12198	ELECT. CHIP 33µF 25V	EY33602520					
C436		9965 000 08945	TANTL. CHIP 10µF 25V	EY10602570					
C451		4822 124 41842	ELECT. CHIP 47µF 16V	EY47601620	JV01		9965 000 02540	JACK NC3FAH2 4P CANON	YJ01004340
C452		4822 124 41842	ELECT. CHIP 47µF 16V	EY47601620	JV02		9965 000 02540	JACK NC3FAH2 4P CANON	YJ01004340
C453		4822 126 11687	CER. CHIP 0.1µF	DK98104200	JV03		4822 267 40792	JACK B6B-PH-K-S	YJ06006260
C454		4822 126 11687	CER. CHIP 0.1µF	DK98104200					
C455		4822 126 11687	CER. CHIP 0.1µF	DK98104200					
C456		4822 126 11687	CER. CHIP 0.1µF	DK98104200					
C457		4822 126 11687	CER. CHIP 0.1µF	DK98104200					
C458		4822 126 11687	CER. CHIP 0.1µF	DK98104200	CE01		4822 126 13396	CER. CHIP 0.047µF ±10% 16V	DK96473200
C462		4822 126 11687	CER. CHIP 0.1µF	DK98104200	CE02		9965 000 08979	FILM CAP. 0.47µF K 250 V	DF16474530
C463		4822 126 11687	CER. CHIP 0.1µF	DK98104200	CE03		4822 126 11687	CER. CHIP 0.1µF	DK98104200
C497		4822 126 14582	CER. CHIP 330pF ±5% CG 50V	DD95331300	CE04		4822 126 11687	CER. CHIP 0.1µF	DK98104200
			PW02-RESISTORS		CE05		4822 126 11687	CER. CHIP 0.1µF	DK98104200
R401		4822 051 30101	CHIP 10Ω ±5% 1/16W	NN05101610	CE06		5322 126 11583	CER. CHIP 0.01µF ±10% B 25V	DK96103200
R402		4822 051 30101	CHIP 10Ω ±5% 1/16W	NN05101610	CE07		5322 126 11583	CER. CHIP 0.01µF ±10% B 25V	DK96103200
R403		4822 051 30103	CHIP 10kΩ ±5% 1/16W	NN05103610					
R404		4822 051 30103	CHIP 10kΩ ±5% 1/16W	NN05103610	RE01		9965 000 08982	CHIP 3.3kΩ ±5% 1/16W	RI05332120
R405		4822 116 82487	CHIP 0Ω ±5% 1/16W	NN05000610	RE02		4822 051 30472	CHIP 4.7kΩ ±5% 1/16W	NN05472610
R406		4822 116 82487	CHIP 0Ω ±5% 1/16W	NN05000610	RE03		4822 111 91414	CHIP 1Ω ±5% 1/10W	NI05100110
R407		4822 051 30272	CHIP 2.7kΩ ±5% 1/16W	NN05272610	RE04		4822 111 91414	CHIP 1Ω ±5% 1/10W	NI05100110
R408		4822 051 30272	CHIP 2.7kΩ ±5% 1/16W	NN05272610					
R409		4822 117 13632	CHIP 100kΩ ±5% 1/16W	NN05104610					
R410		4822 117 13632	CHIP 100kΩ ±5% 1/16W	NN05104610	DE01		9965 000 08936	CHIP DIODE 1SS322	HZ20031050
R415		4822 051 30561	CHIP 56Ω ±5% 1/16W	NN05561610	DE02		4822 130 32955	CHIP DIODE 02CZ5.1-Y	HZ30002050
R416		4822 051 30561	CHIP 56Ω ±5% 1/16W	NN05561610	DE03		4822 130 32955	CHIP DIODE 02CZ5.1-Y	HZ30002050
R431		4822 117 13632	CHIP 100kΩ ±5% 1/16W	NN05104610	QE01		4822 130 63862	DIG.TR.S. RN2315 DTA123YU	BA12315000
R432		4822 051 30101	CHIP 10Ω ±5% 1/16W	NN05101610					
R434		4822 051 30103	CHIP 10kΩ ±5% 1/16W	NN05103610					
R435		4822 051 30272	CHIP 2.7kΩ ±5% 1/16W	NN05272610	JE01		4822 265 31306	JACK MODULAR HJC0212	YJ90001180
R436		4822 117 13632	CHIP 100kΩ ±5% 1/16W	NN05104610	JE03		9965 000 08980	JACK B2B-PH-SM3-TB JST	YJ07019720
R437		4822 051 30101	CHIP 10Ω ±5% 1/16W	NN05101610	JE52		9965 000 08914	JACK B5B-PH-SM3	YJ07019750
R438		4822 117 13632	CHIP 100kΩ ±5% 1/16W	NN05104610	LE01		9965 000 08981	RELAY SY-5W-K	LY10050080
R439		4822 051 30561	CHIP 56Ω ±5% 1/16W	NN05561610	LE02		4822 140 10387	OUTPUT TRANSF. TEL LINE	TO12414010
R440		4822 051 30392	CHIP 3.9kΩ ±5% 1/16W	NN05392610					
R441		4822 051 30474	CHIP 470kΩ ±5% 1/16W	NN05474610					
R442		4822 051 30103	CHIP 10kΩ ±5% 1/16W	NN05103610					
R443		4822 051 30103	CHIP 10kΩ ±5% 1/16W	NN05103610					
R444		4822 051 30103	CHIP 10kΩ ±5% 1/16W	NN05103610	JV01		9965 000 08895	JACK S3B-PH-SM3	YJ07018530
R445		4822 051 30103	CHIP 10kΩ ±5% 1/16W	NN05103610	RV01		9965 000 08983	VRE. 10kΩ A RK0971110	RK01031530
R446		4822 117 13632	CHIP 100kΩ ±5% 1/16W	NN05104610					
			PW02-SEMICONDUCTORS						
D401		9965 000 03083	CHIP DIODE MA6S121	HZ20045020					
Q401		4822 209 90575	IC NJM2068V OP-AMP	HC10168090					
Q403		9965 000 01658	DIG.TR.S. RN1113	BA21113050	RV41		9965 000 03139	VAR. REC VR 10K	RM01031140
Q404		9965 000 01658	DIG.TR.S. RN1113	BA21113050					
Q431		4822 209 90575	IC NJM2068V OP-AMP	HC10168090					
Q432		9965 000 01659	DIG.TR.S. DTC114TE RN1111	BA21111000	JV41				YJ06006450
			PW02-MISCELLANEOUS						
J401		9965 000 02540	JACK 4P CANNON NC3FAH2	YJ01004340					
J431		9965 000 08946	JACK HLJ5305-01-4150	YJ01003710					
J451		9965 000 08947	JACK B10B-PH-SM3	YJ07019800					
L403		4822 157 70322	EMI FILTER NFM61R10T102 1000pF +80%-20%	FM32102010					

NOTE : "nsp" PART IS LISTED FOR REFERENCE ONLY, MARANTZ WILL NOT SUPPLY THESE PARTS.