

Service Manual

PPM100/F1B

PPM100

Portable CD Player

COMPACT
disc
DIGITAL AUDIO

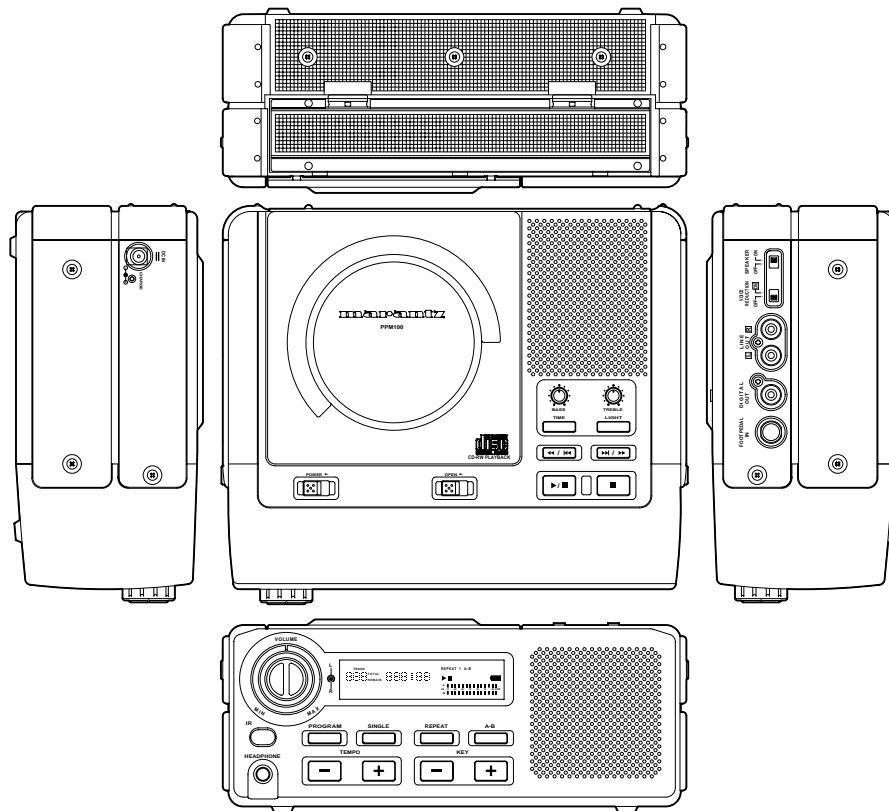

TABLE OF CONTENTS

SECTION	PAGE
1. TECHNICAL SPECIFICATIONS	1
2. SERVICE MODE	2
3. TECHNICAL DESCRIPTION	2
4. ALIGNMENT PROCEDURE	2
5. WIRING DIAGRAM	3
6. BLOCK DIAGRAM	5
7. SCHEMATIC DIAGRAM	7
8. PARTS LOCATIONS	19
9. MICROPROCESSOR AND IC DATA	26
10. EXPLODED VIEW AND MECHANISM PARTS LIST	34
11. ELECTRICAL PARTS LIST	36

Please use this service manual with referring to the user guide (D.F.U.) without fail.

修理の際は、必ず取扱説明書を準備し操作方法を確認の上作業を行ってください。

marantz®

PPM100

MARANTZ DESIGN AND SERVICE

Using superior design and selected high grade components, **MARANTZ** company has created the ultimate in stereo sound. Only original **MARANTZ** parts can insure that your **MARANTZ** product will continue to perform to the specifications for which it is famous.

Parts for your **MARANTZ** equipment are generally available to our National Marantz Subsidiary or Agent.

ORDERING PARTS :

Parts can be ordered either by mail or by Fax.. In both cases, the correct part number has to be specified.

The following information must be supplied to eliminate delays in processing your order :

1. Complete address
2. Complete part numbers and quantities required
3. Description of parts
4. Model number for which part is required
5. Way of shipment
6. Signature : any order form or Fax. must be signed, otherwise such part order will be considered as null and void.

USA

MARANTZ AMERICA, INC.
1100 MAPLEWOOD DRIVE
ITASCA, IL. 60143
USA
PHONE : 630 - 741 - 0300
FAX : 630 - 741 - 0301

EUROPE / TRADING

MARANTZ EUROPE B.V.
P.O.BOX 80002, BUILDING SFF2
5600 JB EINDHOVEN
THE NETHERLANDS
PHONE : +31 - 40 - 2732241
FAX : +31 - 40 - 2735578

BRAZIL

PHILIPS DA AMAZONIA IND. ELET. ITDA
CENTRO DE INFORMACOES AO
CEP 04698-970
SAO PAULO, SP, BRAZIL
PHONE : 0800 - 123123(Discagem Direta Gratuita)
FAX : +55 11 534. 8988

PROFESSIONAL AMERICAS

SUPERSCOPE TECHNOLOGIES, INC.
MARANTZ PROFESSIONAL PRODUCTS
2640 WHITE OAK CIRCLE, SUITE A
AURORA, ILLINOIS 60504 USA
PHONE : 630 - 820 - 4800
FAX : 630 - 820 - 8103

PROFESSIONAL AUSTRALIA

TECHNICAL AUDIO GROUP PTY, LTD
558 DARLING STREET,
BALMAIN, NSW 2041,
AUSTRALIA
PHONE : 61 - 2 - 9810 - 5300
FAX : 61 - 2 - 9810 - 5355

CANADA

LENBROOK INDUSTRIES LIMITED
633 GRANITE COURT,
PICKERING, ONTARIO L1W 3K1
CANADA
PHONE : 905 - 831 - 6333
FAX : 905 - 831 - 6936

AUSTRALIA

QualiFi Pty Ltd,
24 LIONEL ROAD,
MT. WAVERLEY VIC 3149
AUSTRALIA
PHONE : +61 - (0)3 - 9543 - 1522
FAX : +61 - (0)3 - 9543 - 3677

THAILAND

MRZ STANDARD CO.,LTD
746 - 754 MAHACHAI ROAD.,
WANGBURAPAPIROM, PHRANAKORN,
BANGKOK, 10200 THAILAND
PHONE : +66 - 2 - 222 9181
FAX : +66 - 2 - 224 6795

SINGAPORE

WO KEE HONG DISTRIBUTION PTE LTD
130 JOO SENG ROAD
#03-02 OLIVINE BUILDING
SINGAPORE 368357
PHONE : +65 858 5535 / +65 381 8621
FAX : +65 858 6078

NEW ZEALAND

WILDASH AUDIO SYSTEMS NZ
14 MALVERN ROAD MT ALBERT
AUCKLAND NEW ZEALAND
PHONE : +64 - 9 - 8451958
FAX : +64 - 9 - 8463554

TAIWAN

PAI- YUING CO., LTD.
6 TH FL NO, 148 SUNG KIANG ROAD,
TAIPEI, 10429, TAIWAN R.O.C.
PHONE : +886 - 2 - 25221304
FAX : +886 - 2 - 25630415

MALAYSIA

WO KEE HONG ELECTRONICS SDN. BHD.
SUITE 8.1, LEVEL 8, MENARA GENESIS,
NO. 33, JALAN SULTAN ISMAIL,
50250 KUALA LUMPUR, MALAYSIA
PHONE : +60 3 - 2457677
FAX : +60 3 - 2458180

JAPAN *Technical*

MARANTZ JAPAN, INC.
35- 1, 7- CHOME, SAGAMIONO
SAGAMIHARA - SHI, KANAGAWA
JAPAN 228-8505
PHONE : +81 42 748 1013
FAX : +81 42 741 9190

日本マランツ株式会社

本社 〒228-8505
神奈川県相模原市相模大野7-35-1
営業本部 〒150-0022
東京都渋谷区恵比寿南1-11-9

KOREA

MK ENTERPRISES LTD.
ROOM 604/605, ELECTRO-OFFICETEL, 16-58,
3GA, HANGANG-RO, YONGSAN-KU, SEOUL
KOREA
PHONE : +822 - 3232 - 155
FAX : +822 - 3232 - 154

SHOCK, FIRE HAZARD SERVICE TEST :

CAUTION : After servicing this appliance and prior to returning to customer, measure the resistance between either primary AC cord connector pins (with unit NOT connected to AC mains and its Power switch ON), and the face or Front Panel of product and controls and chassis bottom.

Any resistance measurement less than 1 Megohms should cause unit to be repaired or corrected before AC power is applied, and verified before it is return to the user/customer.

Ref. UL Standard No. 1492.

In case of difficulties, do not hesitate to contact the Technical Department at above mentioned address.

1. TECHNICAL SPECIFICATIONS

オーディオ特性

チャンネル	2チャンネル
周波数特性	20Hz ~ 20,000Hz, ± 3 dB
ダイナミックレンジ	68dB以上
S/N比	68dB
チャンネルセパレーション	50dB (1kHz)
高調波歪率	0.1% (1kHz)
ワウフラッター	水晶精度
音声出力 (LINE OUT)	500mV RMS ステレオ
デジタル出力	ピンジャック 0.5 Vp-p 75 Ω
スピーカー出力 (ACアダプター使用時)	2W

光学読み取り方式

波長	780nm
----	-------

信号方式

サンプリング周波数	44.1kHz
-----------	---------

電源部

電源	AC 100V 50/60Hz
消費電力 (電気用品取締法)	6.8W

キャビネット・その他

外形寸法

横	248mm
高さ	100mm
奥行き	205mm
質量	2.2kg
許容動作温度	+5 $^{\circ}$ C ~ +35 $^{\circ}$ C
許容動作湿度	5 ~ 90% (結露のないこと)

付属品

ACアダプター	1個
リモコン	1個
フットスイッチ	1個
保証書	1枚
取扱説明書	1冊

2. SERVICE MODE

- サービスモードへの入り方
[PLAY/PAUSE]と[STOP]ボタンを押しながら電源を入れます。
LCD ディスプレイ部には、下記のように表示します。
PSD MODE#0
SERVICE
 - モード0 (表示 MODE#0)
状態：[FOCUS OFF] [SPINDLE OFF] [RADIAL OFF]
[MUTE ON]
•[FF▶▶]ボタンを押している間だけスレッドが外周へ移動します。ボタンを放すと原点に戻ります。
•[NEXT▶▶]ボタンを押すとモード1へ移行します。
 - モード1 (表示 MODE#1)
状態：[FOCUS ON] [SPINDLE OFF] [RADIAL OFF]
[MUTE ON]
•[NEXT◀◀]ボタンを押すとモード2へ移行します。
•[PREV▶▶]ボタンを押すとモード0へ移行します。
 - モード2 (表示 MODE#2)
状態：[FOCUS ON] [SPINDLE ON] [RADIAL OFF]
[MUTE ON]
•[NEXT◀◀]ボタンを押すとモード3へ移行します。
•[PREV◀◀]ボタンを押すとモード1へ移行します。
 - モード3 (表示 MODE#3)
状態：[FOCUS ON] [SPINDLE ON] [RADIAL ON]
[MUTE OFF]
•[PREV◀◀]ボタンを押すとモード2へ移行します。
- * サービスモードの全ての状態で以下のボタンが有効です。
- [STOP]ボタンを押している間だけLCDが全点灯します。
 - [PLAY]ボタンを押すと通常(サービスモード以外)と同じ動作となります。ただし、上記のLCD各部自動点灯テスト中を除きます。動作中、異常が確認された時にエラー番号が表示されます。(例：Err 10) 下記の表 **Table 1 ERROR CODE** を参考にしてください。
- サービスモードの解除
電源を切るとサービスモードが解除されます

Table 1 ERROR CODE

Error Cod	Error
Err 02	FOCUS Error
Err 10	RADIAL Error
Err 11	SLEDGE Error
Err 13	SPINDLE Error

3. TECHNICAL DESCRIPTION

- TEMPO 機能
 - CD Play キー入力後、ディスクを2倍のスピードで回転させます。その時のデータをSAA7327を通しShock Control・IC SM5904 内蔵のメモリーに一旦蓄えます。
 - メモリーに一旦蓄えたデータをTEMPOの可変量に応じてIC SM5904でデジタル処理し、DAC(アナログ信号変換)へ出力します。
 - 続いてキーコントロールIC CXD2720Q回路で、②によって変化した音程を元に戻し、Audio回路を通し出力します。

TEMPOの可変範囲：+/- 30%

4. ALIGNMENT PROCEDURE

- 条件：
電源 ON
- 調整箇所：
RD17
- 測定箇所：
QD01の16ピンとGND間(PM06)
- 調整方法：
RD17を廻して、電圧が1.8Vになるように調整する。

6. BLOCK DIAGRAM

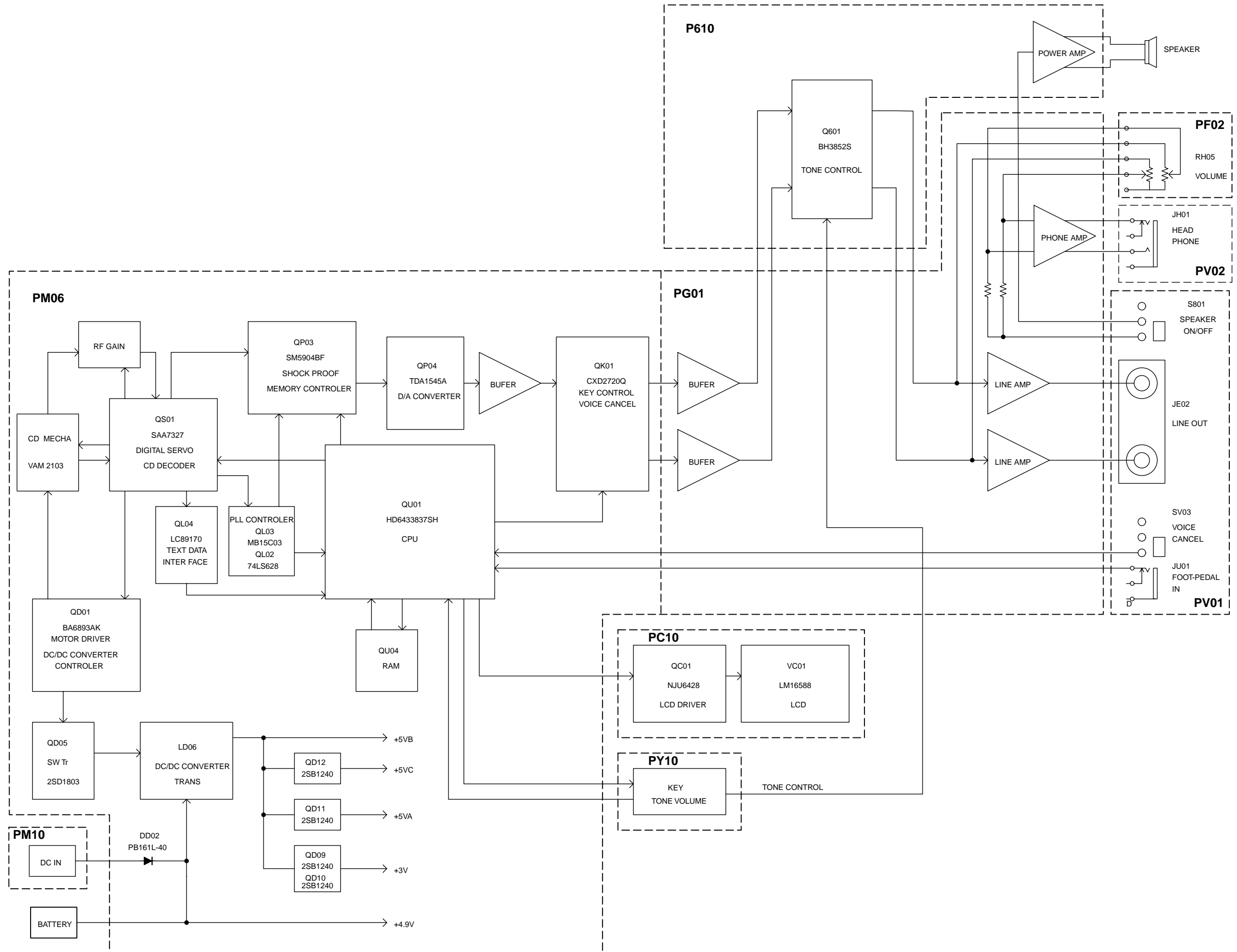

7. SCHEMATIC DIAGRAM

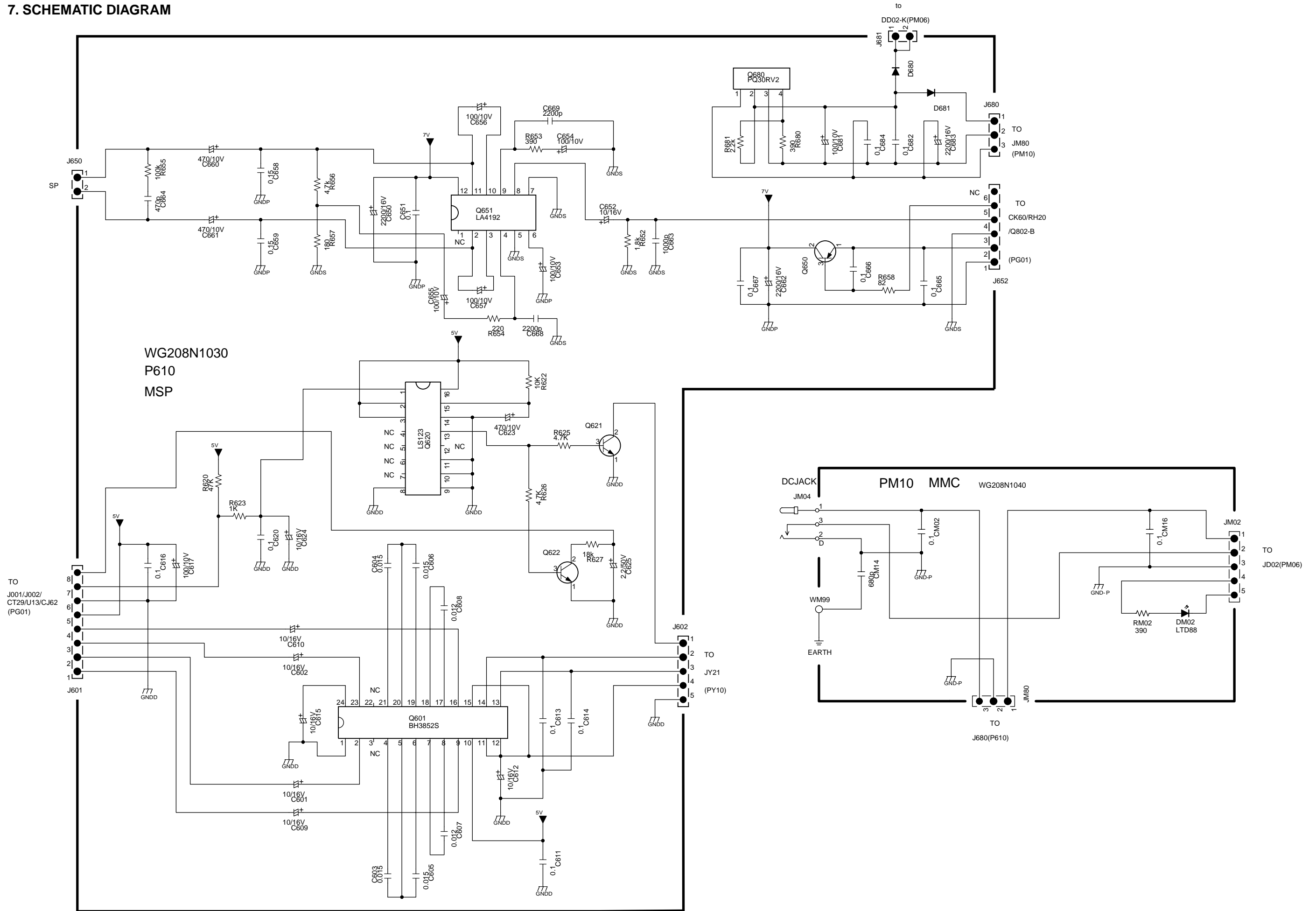

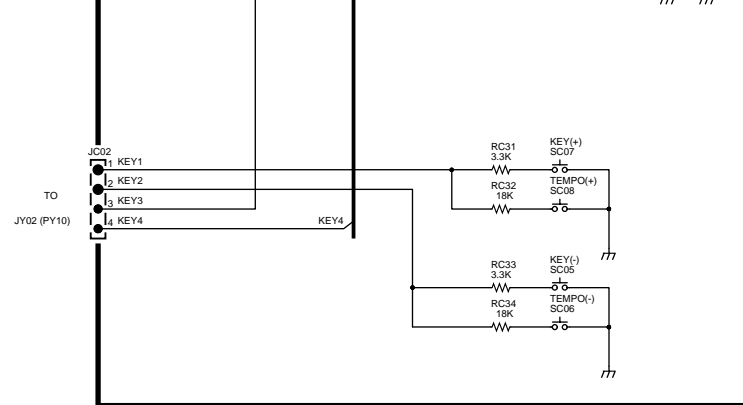
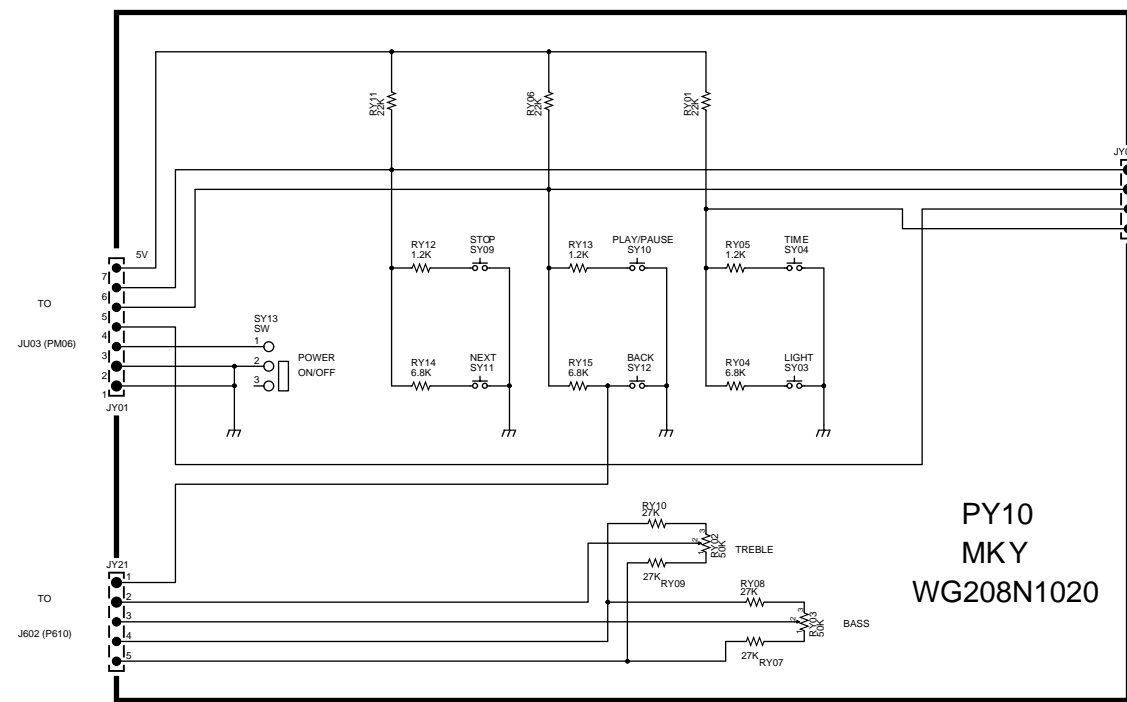
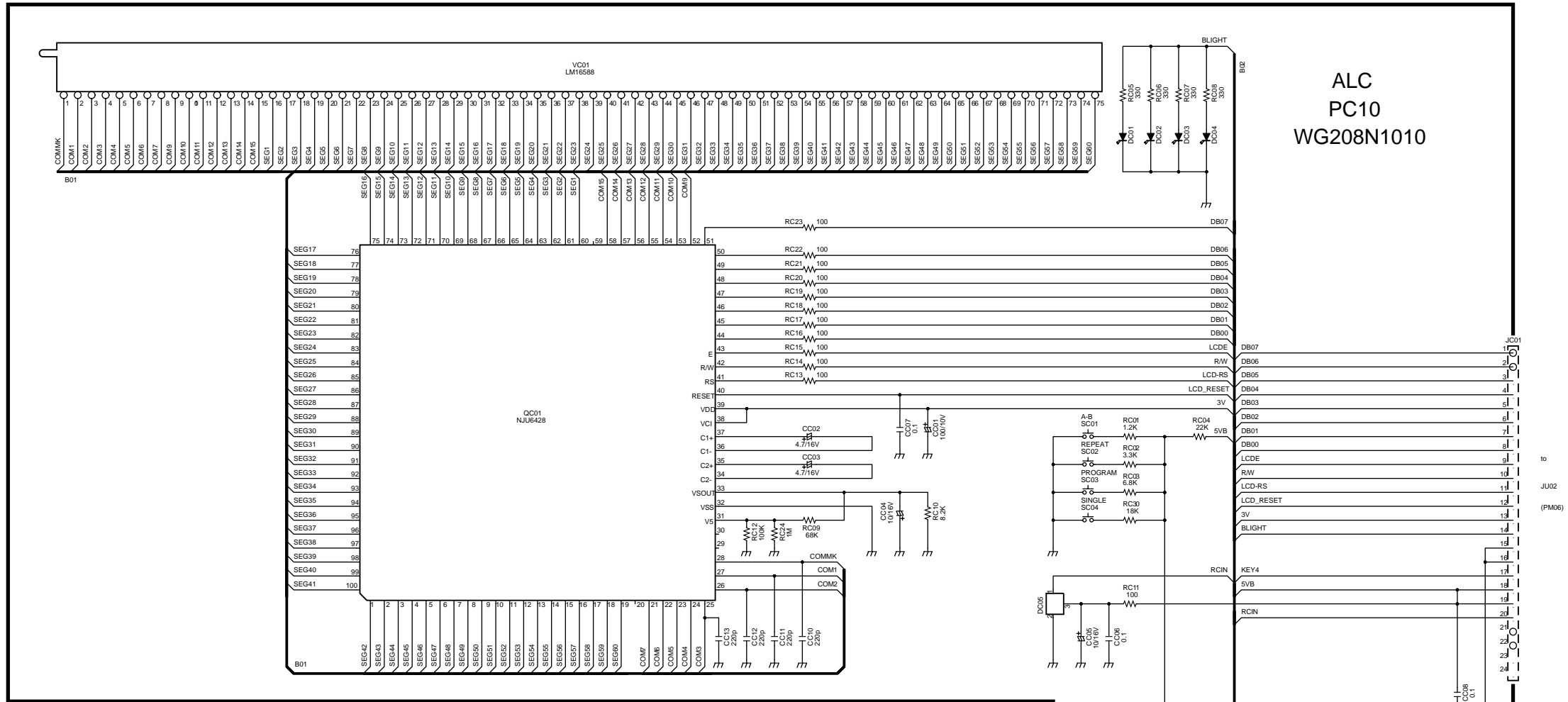

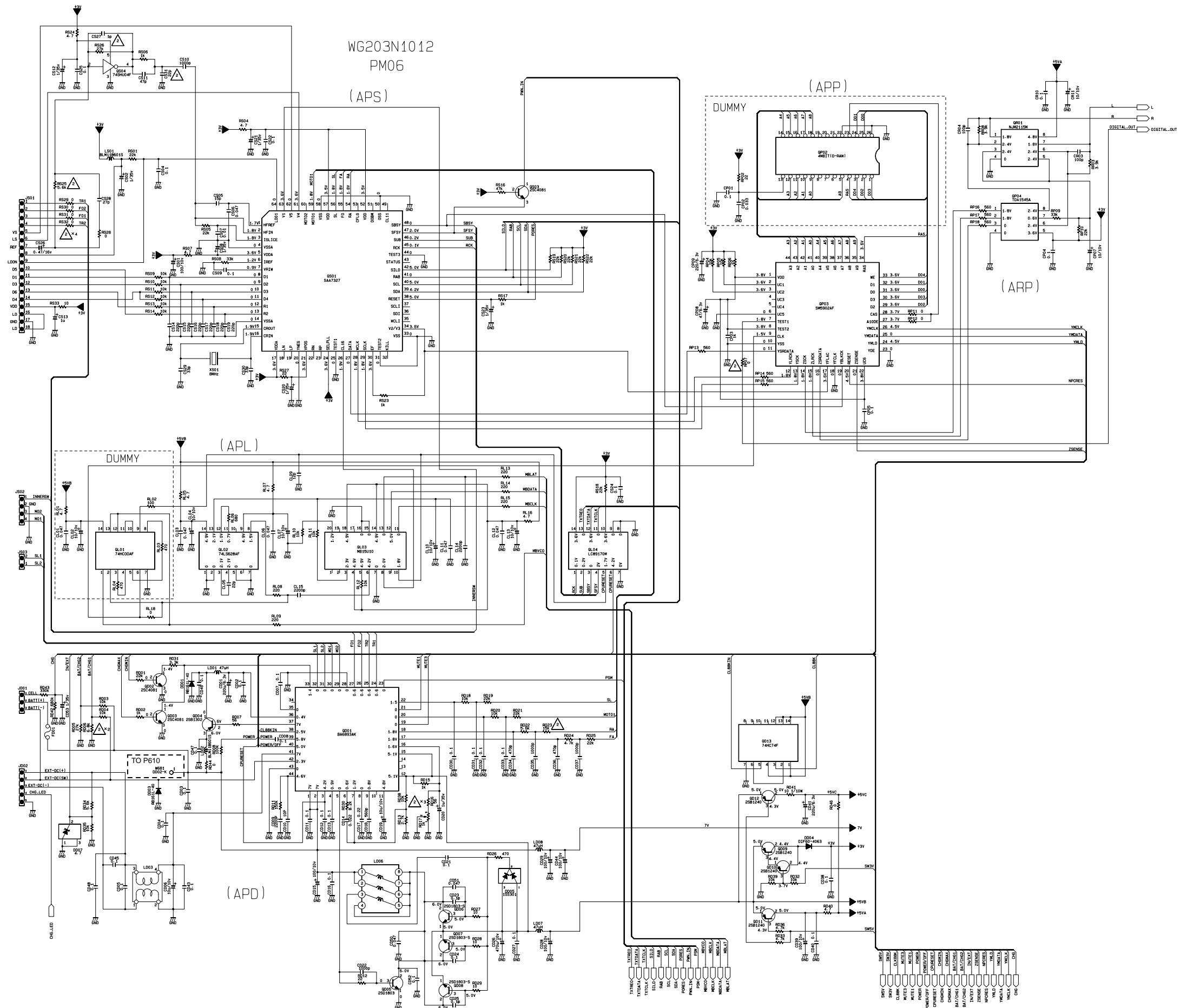

WG203N1012
(PM06) ALA

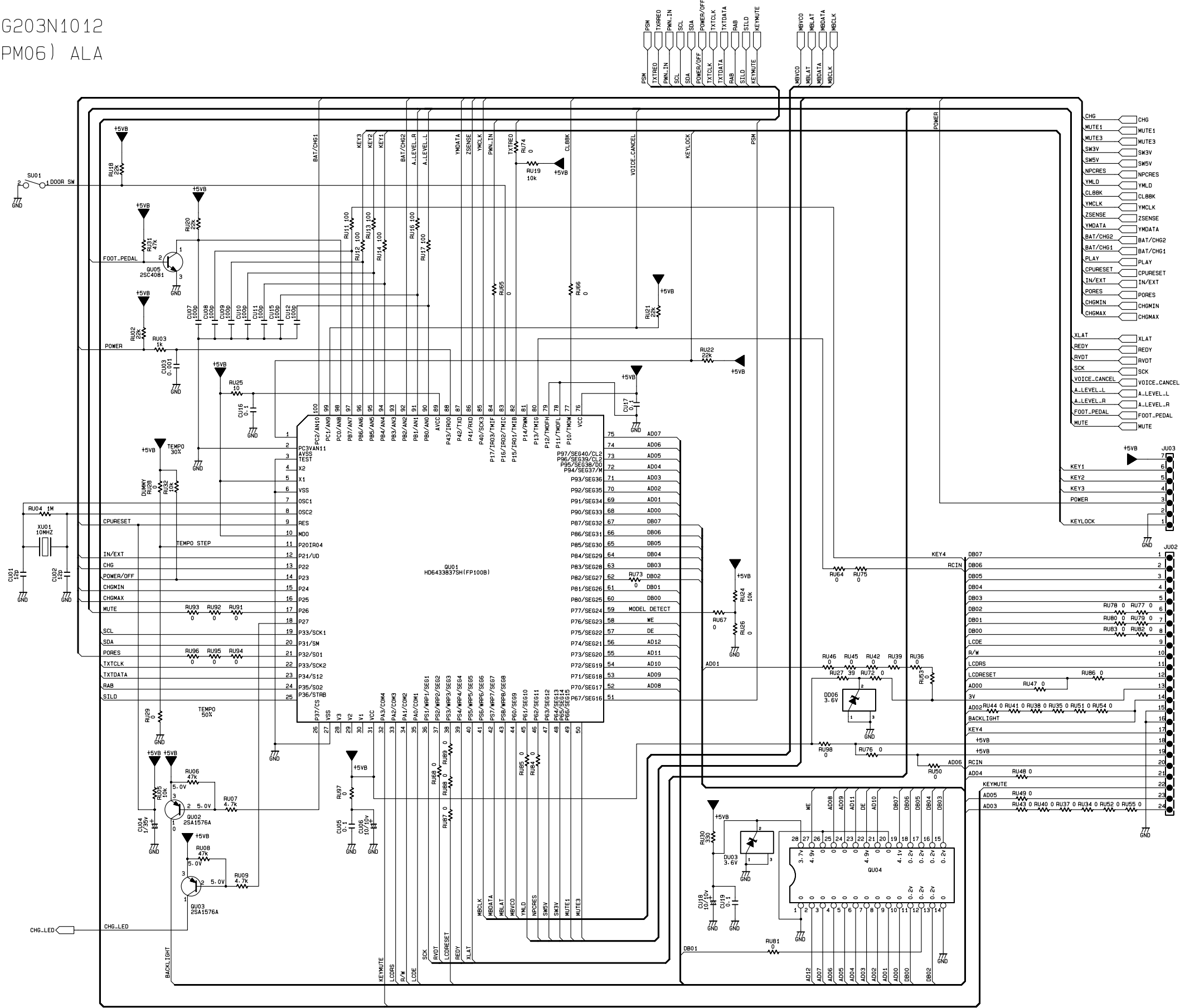

8. PARTS LOCATION

P610

Q651

Q620

Q601

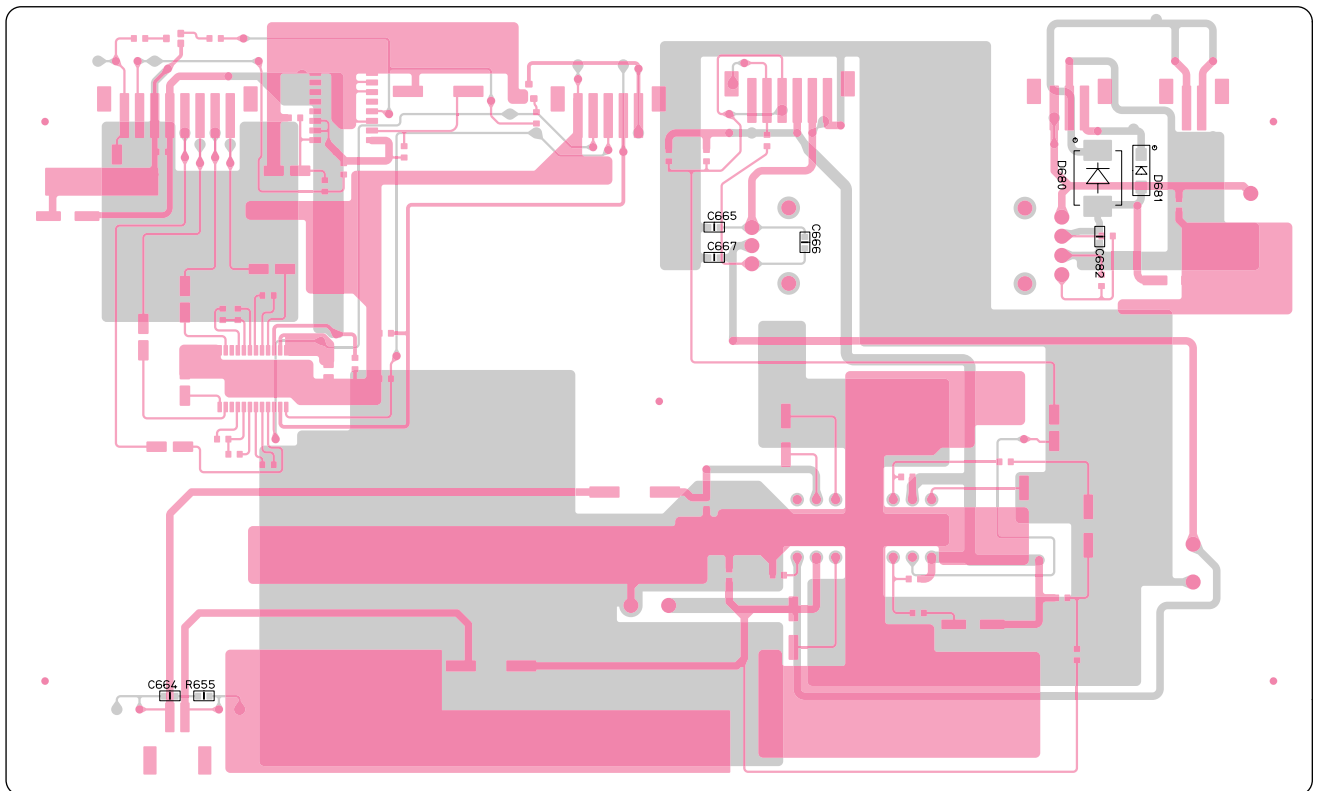
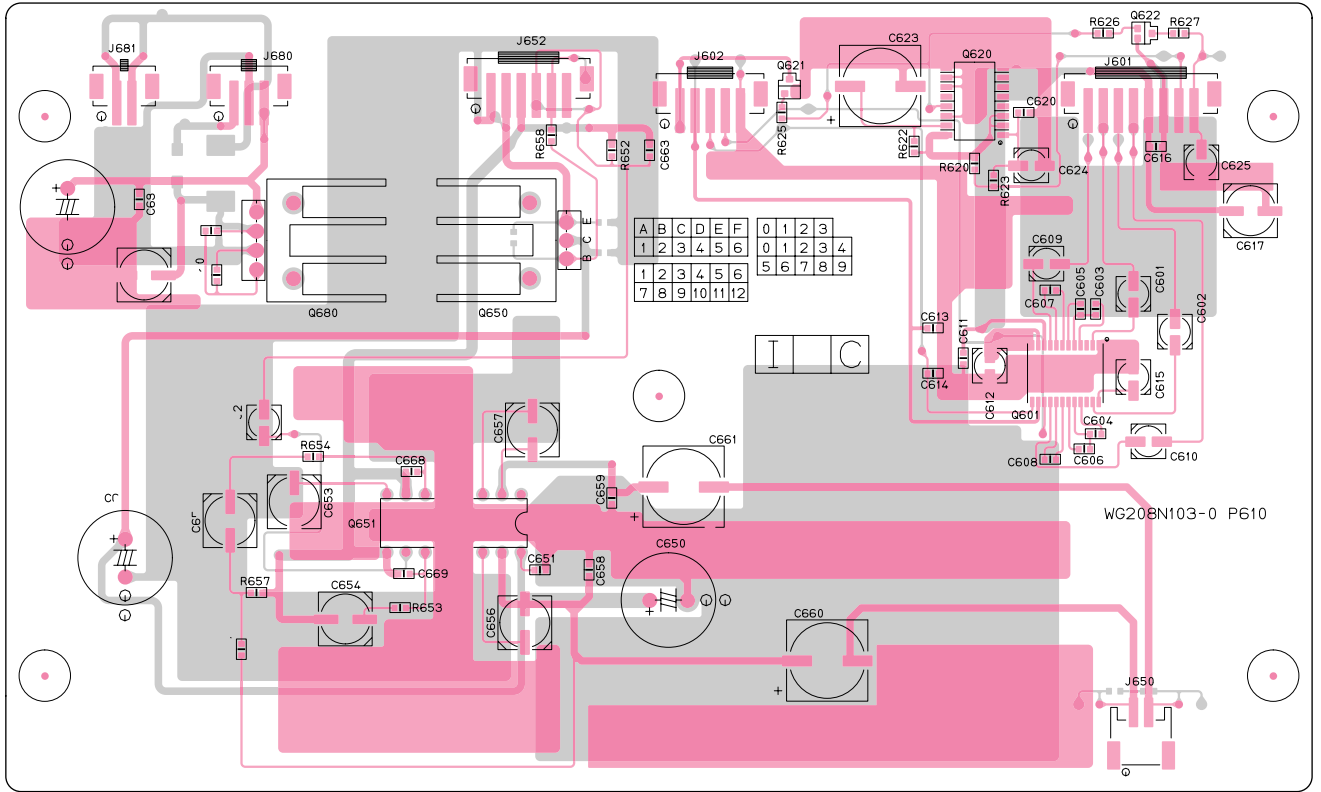

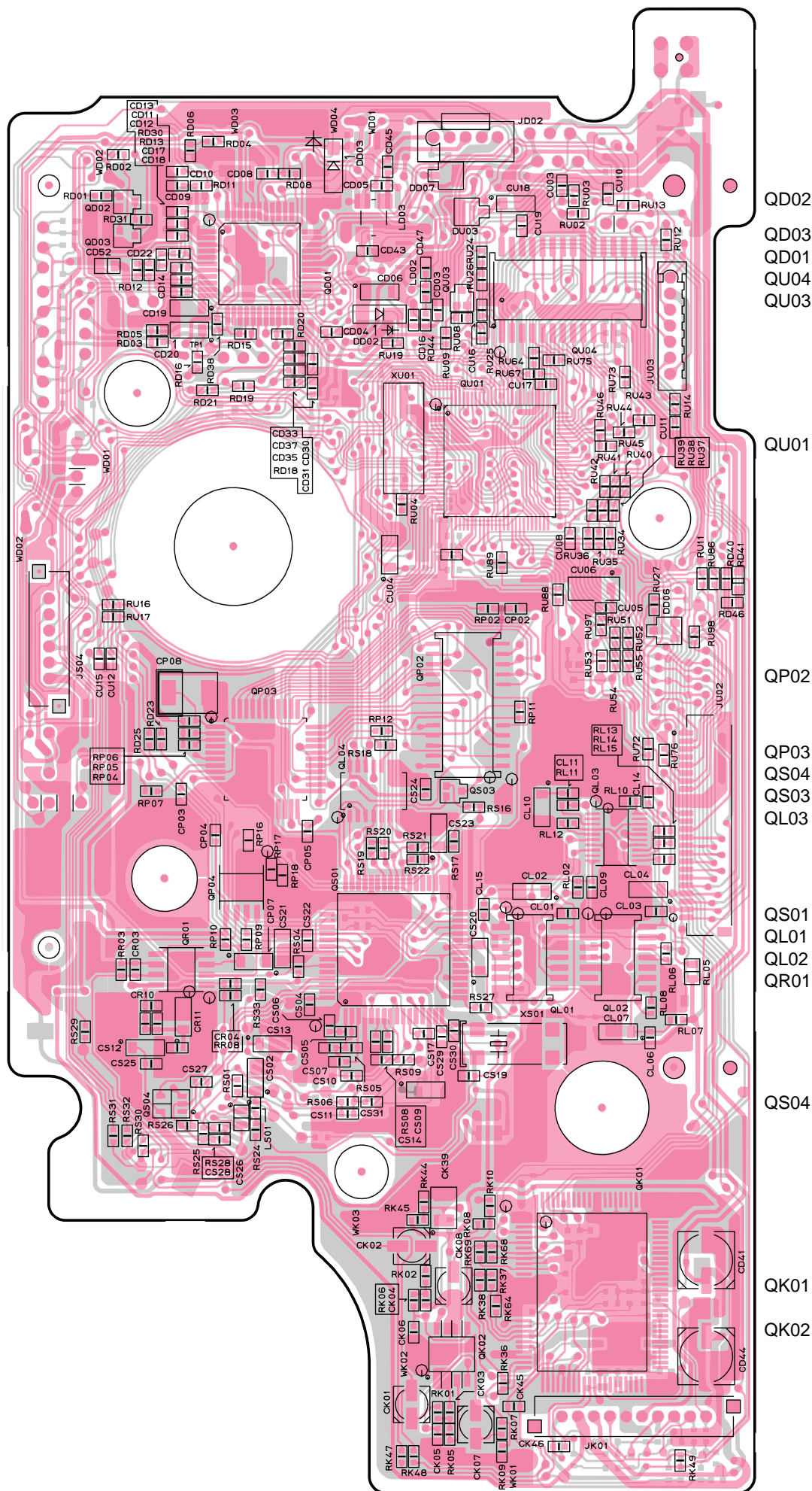

QD02
 QD03
 QD01
 QU04
 QU03

QU01

QP02

QP03
 QS04
 QS03
 QL03

QS01
 QL01
 QL02
 QR01

QS04

QK01

QK02

PC10

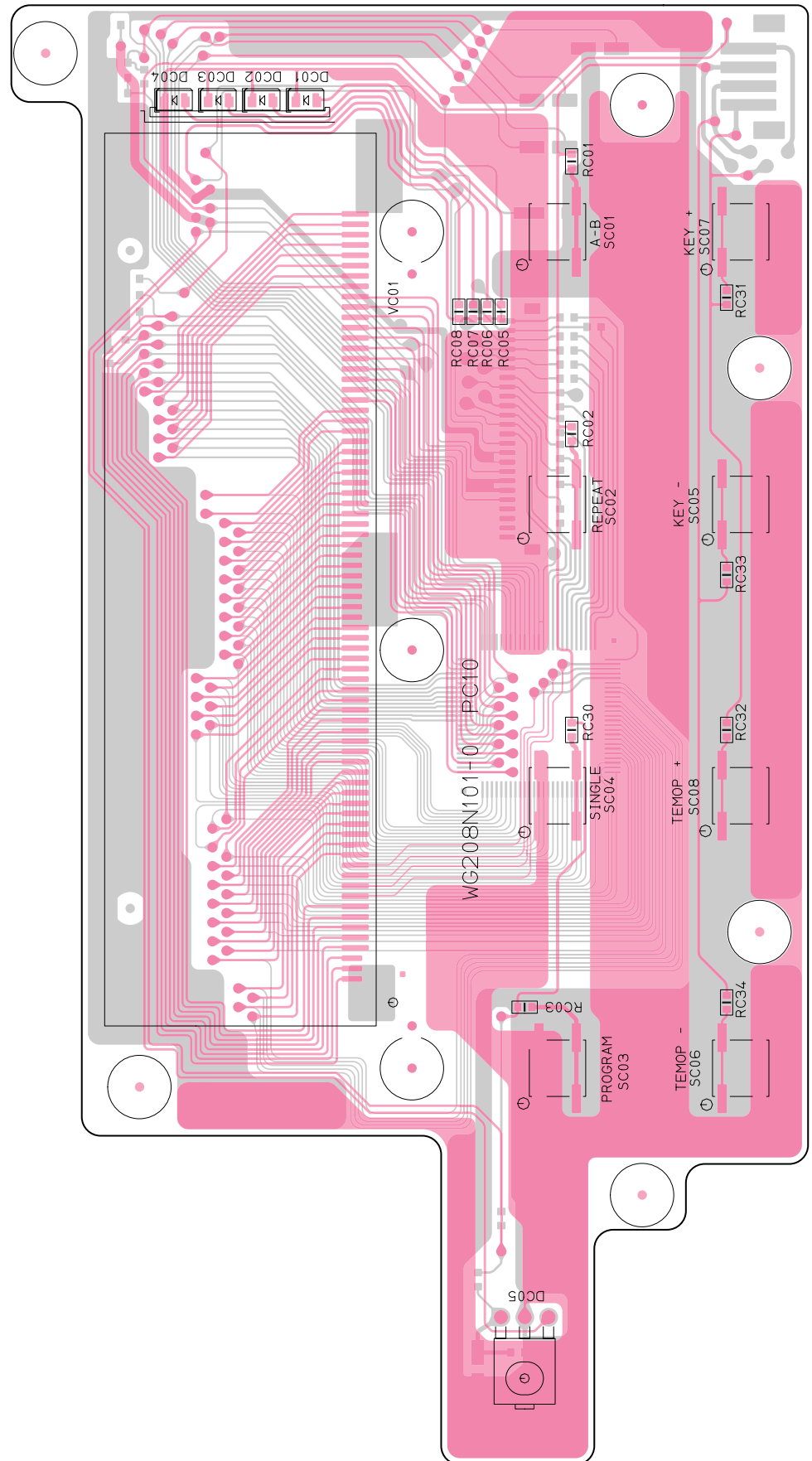

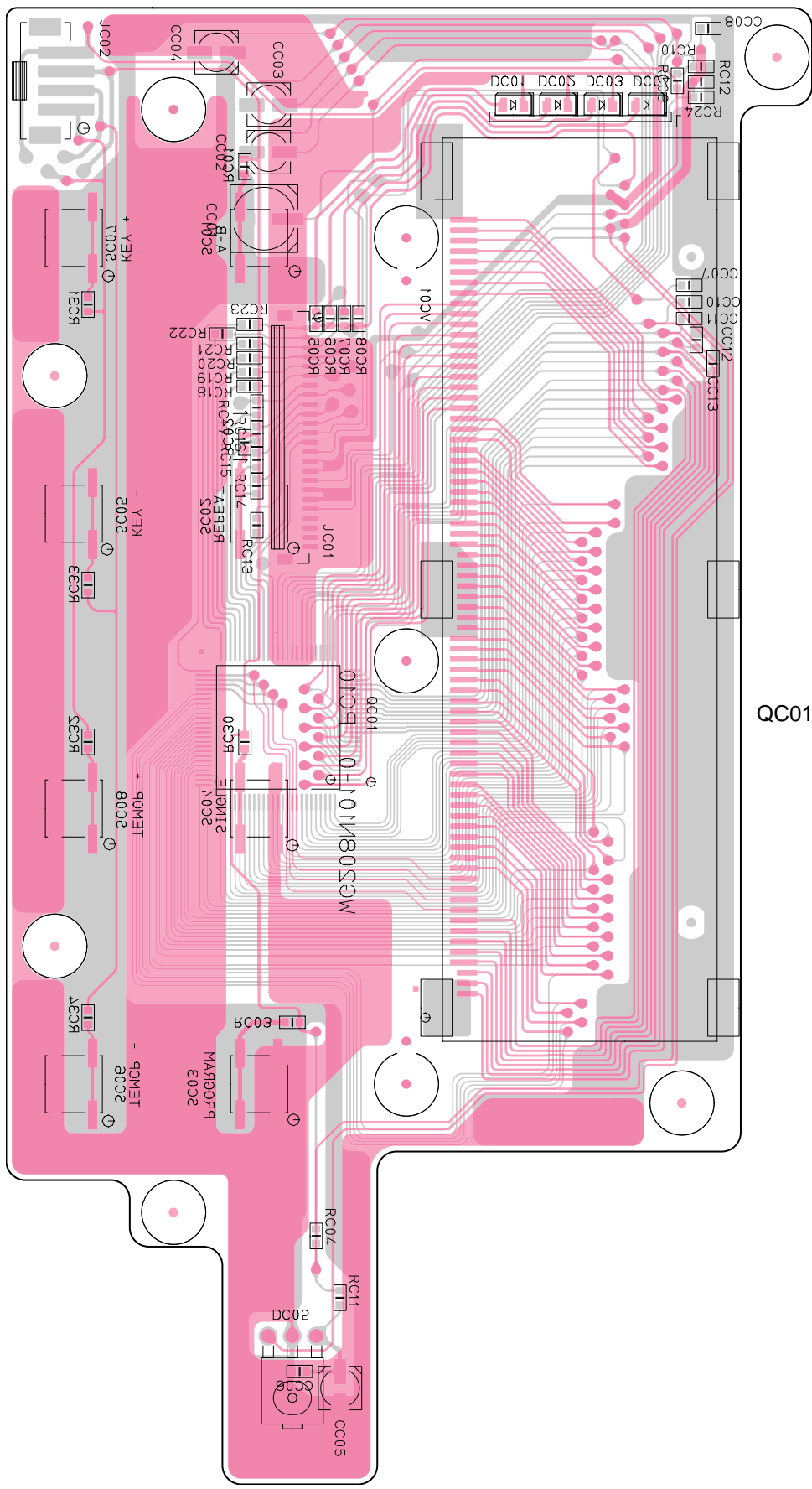

PY10

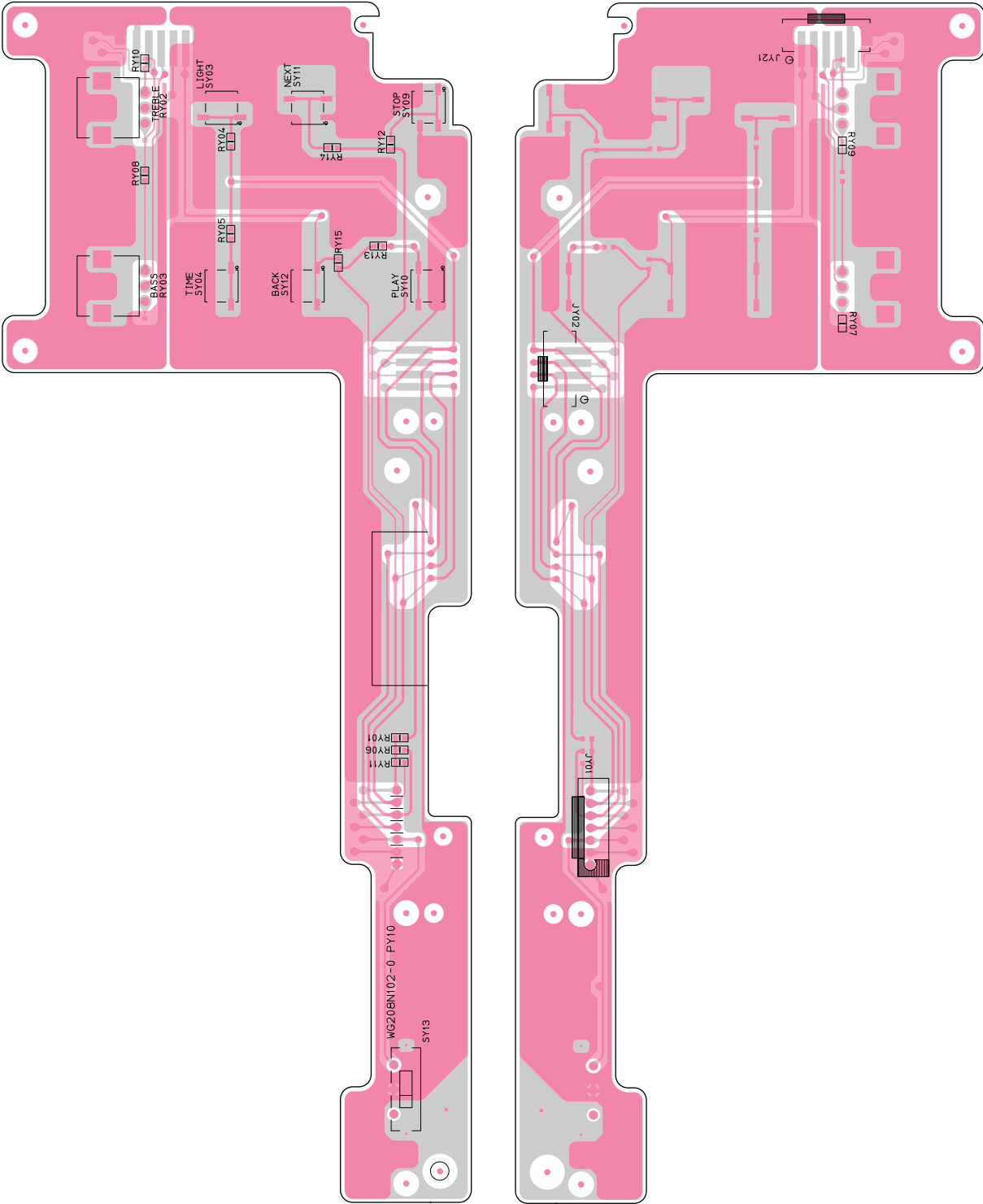

PV01

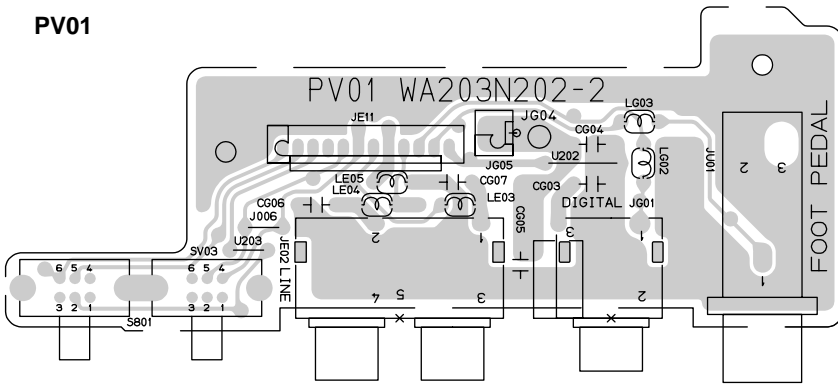

PV02

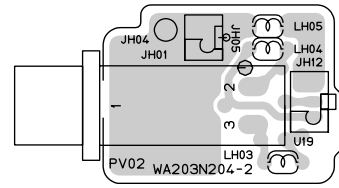

9. MICROPROCESSOR AND IC DATA

QP01 : TDA1545AT

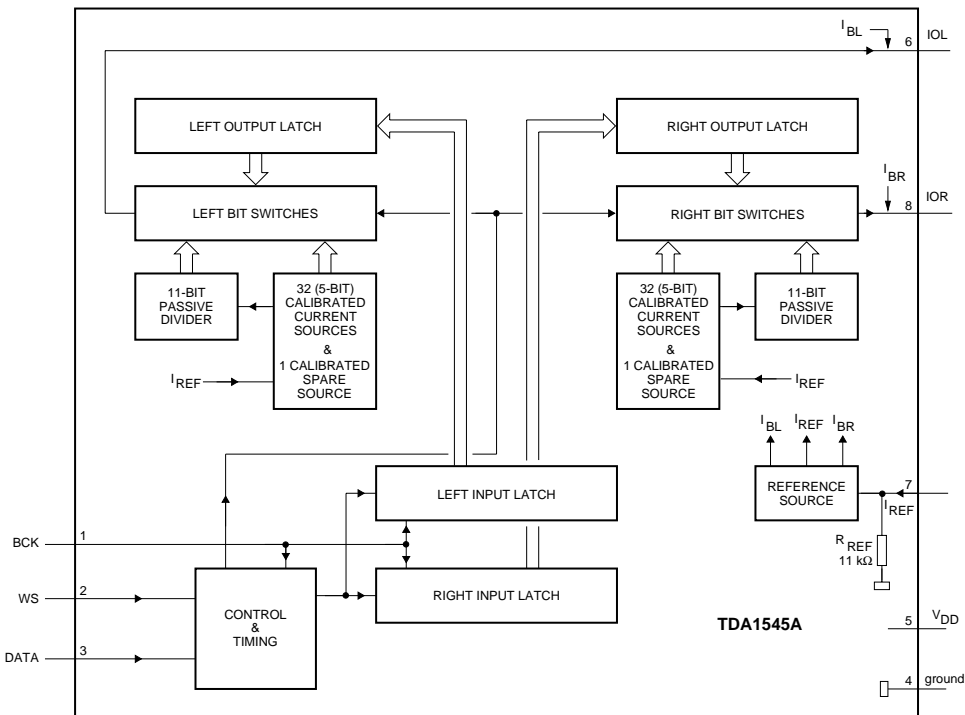

SYMBOL	PIN	DESCRIPTION
BCK	1	bit clock input
WS	2	word select input
DATA	3	data input
GND	4	ground
V _{DD}	5	positive supply voltage
IOL	6	left channel output
I _{REF}	7	reference current input
IOR	8	right channel output

QU01 : HD6473837H

PIN	SYMBOL	DESCRIPTION	PIN	SYMBOL	DESCRIPTION
1	PC3/AN11	key lock sw	26	P37/CS	Back light
2	AVss	ground	27	Vss	ground
3	TEST	ground	28	V3	-
4	X2	-	29	V2	-
5	X1	+5V	30	V1	-
6	Vss	ground	31	Vcc	+5V
7	OSC1	10MHz X'tal	32	PA3/COM4	key mute
8	OSC2	10MHz X'tal	33	PA2/COM3	lcdrs
9	RES	cpu reset	34	PA1/COM2	r/w
10	MD0	+5V	35	PA0/COM1	lcde
11	P20/IRQ4	tempo step	36	P50/WKP0/SEG1	sck
12	P21/UD	in/ext	37	P51/WKP1/SEG2	rvdt
13	P22	chg	38	P52/WKP2/SEG3	lcdreset
14	P23	power	39	P53/WKP3/SEG4	redy
15	P24	chg min	40	P54/WKP4/SEG5	xlat
16	P25	chg max	41	P55/WKP5/SEG6	mbclk
17	P26	mute	42	P56/WKP6/SEG7	mbdata
18	P27	chg led	43	P57/WKP7/SEG8	mblat
19	P30/SCK1	scl	44	P60/SEG9	mbvco
20	P31/SI1	sda	45	P61/SEG10	ymld
21	P32/SO1	Pores	46	P62/SEG11	npcres
22	P33/SCK2	txt clk	47	P63/SEG12	sw5V
23	P34/SI2	txt data	48	P64/SEG13	sw3V
24	P35/SO2	rab	49	P65/SEG14	mute 1
25	P36/STRB	sild	50	P66/SEG15	mute 3

PIN	SYMBOL	DESCRIPTION	PIN	SYMBOL	DESCRIPTION
51	P67/SEG16	PSM	76	Vcc	+5V
52	P70/SEG17	AD08	77	P10/TMOW	CL88K
53	P71/SEG18	AD09	78	P11/TMOFL	GND
54	P72/SEG19	AD10	79	P12/TMOFH	GND
55	P73/SEG20	AD11	80	P13/TMIG	RCIN
56	P74/SEG21	AD12	81	P14/PWM	-
57	P75/SEG22	DE	82	P15/IRQ1/TMIB	TXTREQ
58	P76/SEG23	WE	83	P16/IRQ2/TMIC	DOOR SW
59	P77/SEG24	MODEL SEL	84	P17/IRQ3/TNIF	PWM IN
60	P80/SEG25	DB00	85	P40/SCK3	YMCLK
61	P81/SEG26	DB01	86	P41/RXD	ZSENCE
62	P82/SEG27	DB02	87	P42/TXD	YMDATA
63	P83/SEG28	DB03	88	P43/IRQ0	PLAY
64	P84/SEG29	DB04	89	Avcc	+5V
65	P85/SEG30	DB05	90	PB0/AN0	A LEVEL L
66	P86/SEG31	DB06	91	PB1/AN1	A LEVEL R
67	P87/SEG32	DB07	92	PB2/AN2	BAT/CHG2
68	P90/SEG33	AD00	93	PB3/AN3	-
69	P91/SEG34	AD01	94	PB4/AN4	KEY1
70	P92/SEG35	AD02	95	PB5/AN5	KEY2
71	P93/SEG36	AD03	96	PB6/AN6	KEY3
72	P94/SEG37/M	AD04	97	PB7/AN7	KEY4
73	P95/SEG38/DO	AD05	98	PC0/AN8	FOOT PEDAL
74	P96/SEG39/CL2	AD06	99	PC1/AN9	VOIC CANCEL
75	P97/SEG40/CL1	AD07	100	PC2/AN10	BAT/CHG1

QC01 : MJU6428CF

NJU6428CF

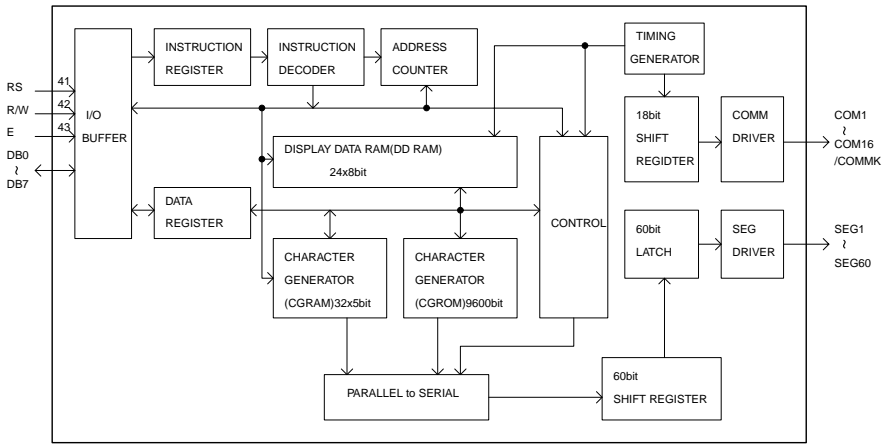

Q651 : LA4192

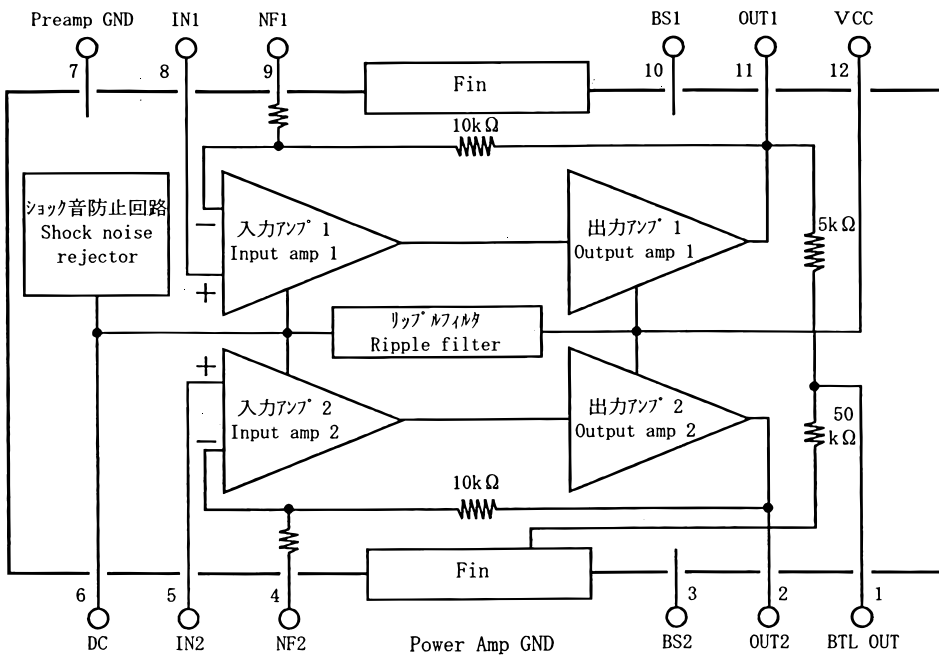

QK01 : CXD2720Q

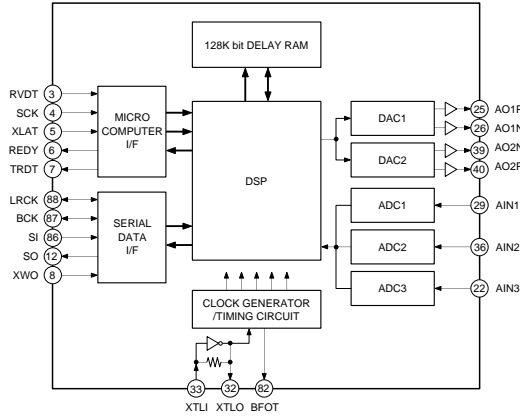

Pin No.	Symbol	I/O	Description
1	AVs0	—	DRAM digital GND.
2	Vss0	—	Digital GND.
3	RVDT	I	Data input for microcomputer interface.
4	SCK	I	Shift clock input for microcomputer interface.
5	XLAT	I	Latch input for microcomputer interface.
6	REDY	O	Transmission enabling signal output for microcomputer interface. Transmission prohibited when Low.
7	TRDT	O	Serial data output for microcomputer interface.
8	XWO	I	Window open input for synchronization. Normally High.
9	XRST	I	System reset input. Resets when Low.
10	Vss1	—	Digital GND.
11	Vdd0	—	Digital power supply.
12	SO	O	1-sampling 2-channel serial data output.
13	XS24	I	Serial data 24-/32-bit slot selection. 24-bit slot when Low. (valid for slave mode)
14	TST0	I	Test pin. Normally set Low.
15	TST1	I	Test pin. Normally set Low.
16	TST2	I	Test pin. Normally set Low.
17	TST3	I	Test pin. Normally set Low.
18	TST4	I	Test pin. Normally set Low.
19	TST5	I	Test pin. Normally set Low.
20	Vss2	—	Digital GND.
21	AVs3	—	CH3 AD converter GND.
22	AIN3	I	CH3 AD converter analog input (for microphone input).
23	AVd3	—	CH3 AD converter power supply.
24	AVd4	—	CH1 DA converter power supply.
25	AO1P	O	CH1 DA converter analog positive phase output.
26	AO1N	O	CH1 DA converter analog reversed phase output.
27	AVs4	—	CH1 DA converter GND.
28	AVs1	—	CH1 AD converter GND.
29	AIN1	I	CH1 AD converter analog input.
30	AVd1	—	CH1 AD converter power supply.
31	XVdd	—	Digital power supply for master clock.
32	XTLO	O	Crystal oscillator circuit output.
33	XTLI	I	Crystal oscillator circuit input.
34	XVss	—	Digital GND for master clock.
35	AVs2	—	CH2 AD converter GND.

Pin No.	Symbol	I/O	Description
36	AIN2	I	CH2 AD converter analog input.
37	AVo2	—	CH2 DA converter power supply.
38	AVo5	—	CH2 DA converter power supply.
39	AO2N	O	CH2 DA converter analog reversed phase output.
40	AO2P	O	CH2 DA converter analog positive phase output.
41	AVs5	—	CH2 DA converter GND.
42	Vss3	—	Digital GND.
43	Vdd1	—	Digital power supply.
44 to 52	NC	—	Normally open.
53	Vss4	—	Digital GND.
54 to 68	NC	—	Normally open.
69	Vss5	—	Digital GND.
70	Vdd2	—	Digital power supply.
71 to 79	NC	—	Normally open.
80	Vss6	—	Digital GND.
81	X768	I	Test input pin. Normally set Low.
82	BFOT	O	Clock, frequency-divider output (384fs).
83	INVI	I	Test pin. Normally set Low.
84	NC	—	Normally open.
85	NC	—	Normally open.
86	SI	I	1-sampling 2-channel serial data input.
87	BCK	I/O	Serial bit transmission clock for serial input/output data SI and SO.
88	LRCK	I/O	Sampling frequency clock for serial input/output data SI and SO.
89	XMST	I	BCK, LRCK master/slave mode switching input. Master mode when Low.
90	Vss7	—	Digital GND.
91 to 98	NC	—	Normally open.
99	Vdd3	—	Digital power supply.
100	AVo0	—	Digital power supply for DRAM.

QS01 : SAA7327H

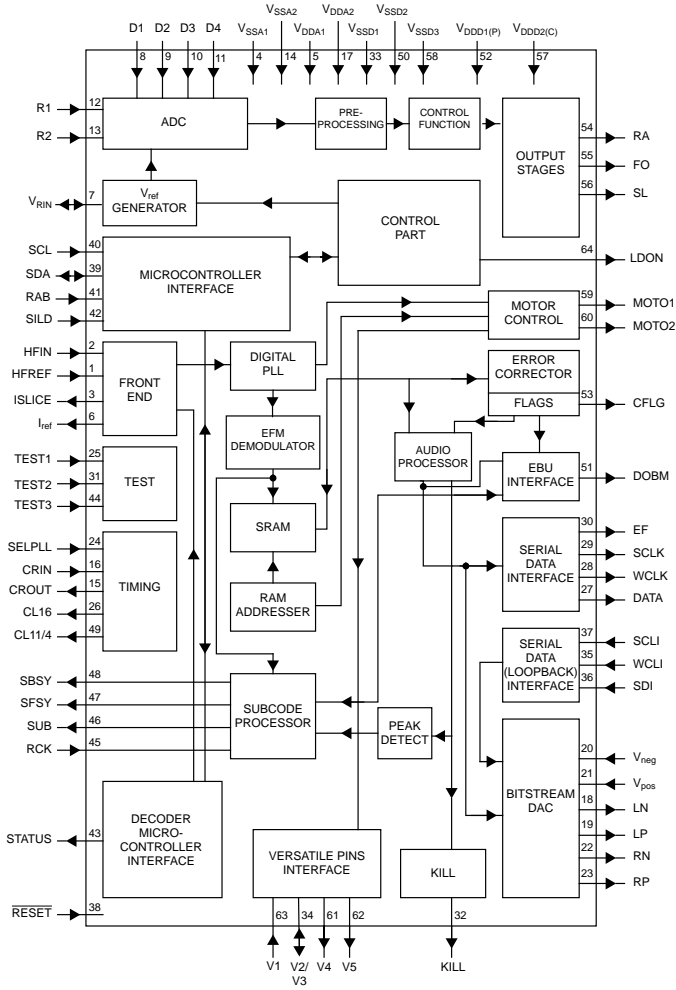

SYMBOL	PIN	DESCRIPTION
HFREF	1	comparator common mode input
HFIN	2	comparator signal input
ISLICE	3	current feedback output from data slicer
VSSA1	4 ⁽¹⁾	analog ground 1
VDDA1	5 ⁽¹⁾	analog supply voltage 1
Iref	6	reference current output pin
Vrin	7	reference voltage for servo ADC's
D1	8	unipolar current input (central diode signal input)
D2	9	unipolar current input (central diode signal input)
D3	10	unipolar current input (central diode signal input)
D4	11	unipolar current input (central diode signal input)
R1	12	unipolar current input (satellite diode signal input)
R2	13	unipolar current input (satellite diode signal input)
VSSA2	14 ⁽¹⁾	analog ground 2
CROUT	15	crystal/resonator output
CRIN	16	crystal/resonator input
VDDA2	17 ⁽¹⁾	analog supply voltage 2
LN	18	DAC left channel differential output - negative
LP	19	DAC left channel differential output - positive
Vneg	20	DAC negative reference input
Vpos	21	DAC positive reference input
RN	22	DAC right channel differential output - negative
RP	23	DAC right channel differential output - positive
SELPLL	24	selects whether internal clock multiplier PLL is used
TEST1	25	test control input 1; this pin should be tied LOW
CL16	26	16.9344 MHz system clock output
DATA	27	serial d4(1)ata output (3-state)
WCLK	28	word clock output (3-state)
SCLK	29	serial bit clock output (3-state)
EF	30	C2 error flag output (3-state)
TEST2	31	test control input 2; this pin should be tied LOW
KILL	32	kill output (programmable; open-drain)
VSSD1	33 ⁽¹⁾	digital ground 2
V2/V3	34	versatile I/O: input versatile pin 2 or output versatile pin 3 (open-drain)
WCLI	35	word clock input (for data loopback to DAC)
SDI	36	serial data input (for data loopback to DAC)
SCLI	37	serial bit clock input (for data loopback to DAC)
RESET	38	power-on reset input (active LOW)
SDA	39	microcontroller interface data I/O line (open-drain output)
SCL	40	microcontroller interface clock line input

SYMBOL	PIN	DESCRIPTION
RAB	41	microcontroller interface R/W and load control line input (4-wire bus mode)
SILD	42	microcontroller interface R/W and load control line input (4-wire bus mode)
STATUS	43	servo interrupt request line/decoder status register output (open-drain)
TEST3	44	test control input 3; this pin should be tied LOW
RCK	45	subcode clock input
SUB	46	P-to-W subcode bits output (3-state)
SFSY	47	subcode frame sync output (3-state)
SBSY	48	subcode block sync output (3-state)
CL11/4	49	11.2896 MHz or 4.2336 MHz (for microcontroller) clock output
VSSD2	50 ⁽¹⁾	digital ground 3
DOBM	51	bi-phase mark output (externally buffered; 3-state)
VDD1(P)	52 ⁽¹⁾	digital supply voltage 2 for periphery
CFLG	53	correction flag output (open-drain)
RA	54	radial actuator output
FO	55	focus actuator output
SL	56	sledge control output
VDD2(C)	57 ⁽¹⁾	digital supply voltage 3 for core
VSSD3	58 ⁽¹⁾	digital ground 4
MOTO1	59	motor output 1; versatile (3-state)
MOTO2	60	motor output 2; versatile (3-state)
V4	61	versatile output pin 4
V5	62	versatile output pin 5
V1	63	versatile input pin 1
LDON	64	laser drive on output (open-drain)

Note
1. All supply pins must be connected to the same external power supply voltage.

QH05 : TDA1308

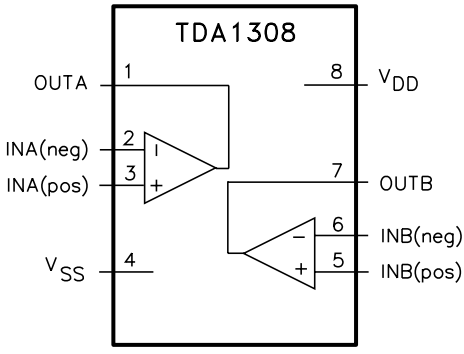

SYMBOL	PIN	DESCRIPTION
OUTA	1	output A
INA(neg)	2	inverting input A
INA(pos)	3	non-inverting input A
VSS	4	negative supply
INB(pos)	5	non-inverting input B
INB(neg)	6	inverting input B
OUTB	7	output B
VDD	8	positive supply

QP03 : SM5904BF

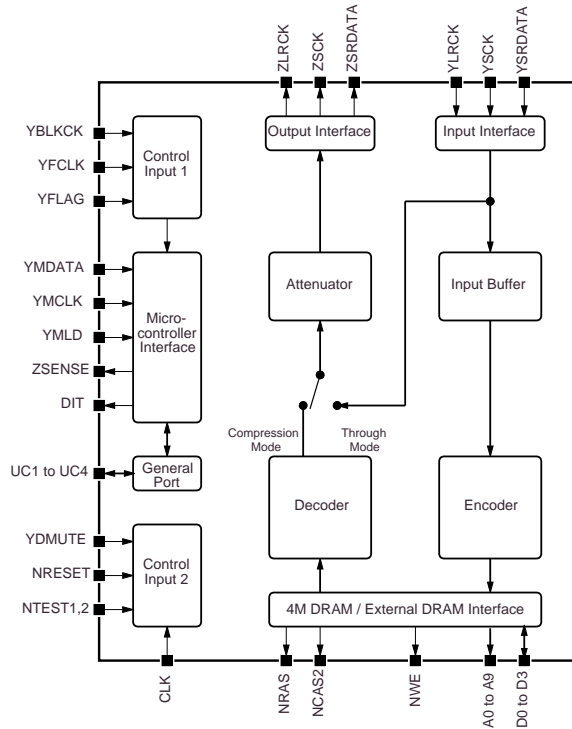

Pin number	Pin name	I/O	Function	Setting	
				H	L
1	VDD2	-	VDD supply pin		
2	UC1	Ip/O	Microcontroller interface extension I/O 1		
3	UC2	Ip/O	Microcontroller interface extension I/O 2		
4	UC3	Ip/O	Microcontroller interface extension I/O 3		
5	UC4	Ip/O	Microcontroller interface extension I/O 4		
6	VSS2	-	Ground		
7	DIT	O	Digital audio interface		
8	NTEST1	Ip	Test pin		Test
9	CLK	I	16.9344 MHz clock input		
10	VSS1	-	Ground		
11	YSRDATA	I	Audio serial input data		
12	YLRCCK	I	Audio serial input LR clock	Left Ch.	Right Ch.
13	YSCK	I	Audio serial input bit clock		
14	ZSCK	O	Audio serial output bit clock		
15	ZLRCK	O	Audio serial output LR clock	Left Ch.	Right Ch.
16	ZSRDATA	O	Audio serial output data		
17	YFLAG	I	Signal processor IC RAM overflow flag		Overflow
18	YFCLK	I	Crystal-controlled frame clock		
19	YBLKCK	I	Subcode block clock signal		
20	NRESET	I	System reset pin		Reset
21	ZSENSE	O	Microcontroller interface status output		
22	VDD1	-	VDD supply pin		
23	YDMUTE	I	Forced mute pin	Mute	
24	YMLD	I	Microcontroller interface latch clock		
25	YMDATA	I	Microcontroller interface serial data		
26	YMCLK	I	Microcontroller interface shift clock		
27	NTEST2	Ip	Test pin		Test
28	NCAS2	O	DRAM2 $\overline{C\bar{A}S}$ control(Use External DRAM)		
29	D2	Ip/O	DRAM data input/output 2		
30	D3	Ip/O	DRAM data input/output 3		
31	D0	Ip/O	DRAM data input/output 0		
32	D1	Ip/O	DRAM data input/output 1		
33	NWE	O	DRAM $\overline{W\bar{E}}$ control		
34	NRAS	O	DRAM $\overline{R\bar{A}S}$ control		
35	A9	O	DRAM address 9		
36	A8	O	DRAM address 8		
37	A7	O	DRAM address 7		
38	A6	O	DRAM address 6		
39	A5	O	DRAM address 5		
40	A4	O	DRAM address 4		
41	A0	O	DRAM address 0		
42	A1	O	DRAM address 1		
43	A2	O	DRAM address 2		
44	A3	O	DRAM address 3		

Ip : Input pin with pull-up resistor Ip/O : Input/Output pin (With pull-up resistor when in input mode)
 28, 33 to 44 pins for high-impedance output and 29 to 32 pins for input pull-up condition except for using external DRAM

Q601 : BH3852FS

Block diagram

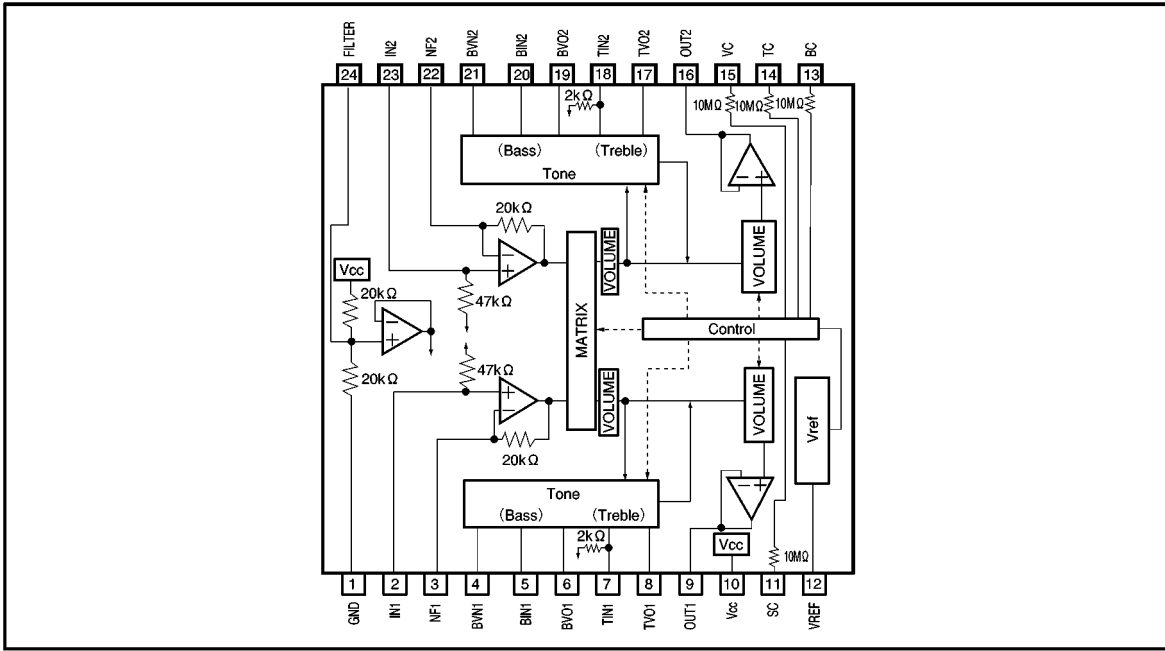

Pin descriptions

Pin No.	Pin name	Function	Pin No.	Pin name	Function
1	GND	Ground	13	BC	Bass control pin
2	IN1	Channel 1 volume input	14	TC	Treble control pin
3	NF1	Input-stage amplifier gain setting	15	VC	Volume control pin
4	BVN1	Channel 1 bass filter	16	OUT2	Channel 2 volume output
5	BIN1	Channel 1 bass filter	17	TVO2	Channel 2 treble filter
6	BVO1	Channel 1 bass filter	18	TIN2	Channel 2 treble filter
7	TIN1	Channel 1 treble filter	19	BVO2	Channel 2 bass filter
8	TVO1	Channel 1 treble filter	20	BIN2	Channel 2 bass filter
9	OUT1	Channel 1 volume out	21	BVN2	Channel 2 bass filter
10	V _{cc}	Power supply	22	NF2	Input-stage amplifier gain stage
11	SC	Surround control pin	23	IN2	Channel 2 volume input
12	VREF	Reference voltage output	24	FILTER	Filter pin

Q620 : 74HC123

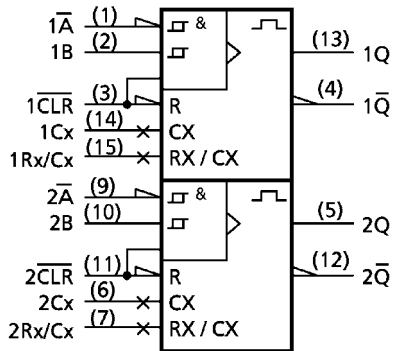

INPUTS			OUTPUTS		NOTE
\bar{A}	B	\bar{CLR}	Q	\bar{Q}	
\bar{L}	H	H			OUTPUT ENABLE
X	L	H	L	H	INHIBIT
H	X	H	L	H	INHIBIT
L	\bar{L}	H			OUTPUT ENABLE
L	H	\bar{L}			OUTPUT ENABLE
X	X	L	L	H	RESET

X : Don't Care

Note :

POS. NO	VERS. COLOR	PART NO. (FOR PCS)	DESCRIPTION	PART NO. (MJI)	POS. NO	VERS. COLOR	PART NO. (FOR PCS)	DESCRIPTION	PART NO. (MJI)
001B			FRONT PANEL K	208N248510				PACKING USER MANUAL USER MANUAL FLY SHEET	208N851010
002B			FRONT PANEL	208N248010	001T				208N851110
005B			BUTTON	378V270320	002T				
006B		4822 381 11426	IR LENS	431T355010					
008B			WINDOW & ADHESIVE	208N158010	▲ A001		A.C ADAPTOR 9V 2A		AA10009170
010B		9965 000 03146	KNOB REC VOL.R	409S154030	A002		UNIT KIT		ZK208N0010
011B			KNOB REC VOL.L ASSY	409S154550			FOOT SWITCH SFTS-1B		
012B			KNOB REC VOL.L	409S154040	A003		REMOTE CONTROLLER		ZK208N0020
013B			RUBBER RING	377V066110			RC-PPM		
018B			NET SPEAKER	208N202010					
023B			BRACKET HEAD PHONE	409S160040					
024B		9965 000 01559	CLAMPER HEAD PHONE	214K005010					
027B			SPACER LCD	409S118300					
028B			REFLECTOR SEET	409S274010					
029B			HOLDER LCD	409S271300					
030B			LENS LCD	409S355300					
031B			SHEET	409S107300					
032B			CONTACTOR RUBBER	409S123010					
001F			MAIN FRAME	203N401010					
003F			SIDE PANEL R	203N249010					
005F			SIDE PANEL ASSY	203N249530					
006F			SIDE PANEL L	203N249120					
007F			LENS	409S355010					
016F		4822 290 40212	TERMINAL CONTACTOR -	YL11010090					
017F		4822 290 60593	TERMINAL CONTACTOR +	153T129010					
018F		4822 290 60594	TERMINAL CONTACTOR +	153T129020					
020F		4822 426 50757	LID BATTERY	153T257010					
021F		4822 462 71423	BUFFER BATTERY	3411056050					
022F		9965 000 03151	BRACKET SIDE	378V160040					
030F			LID BOTTOM	203N257160					
031F		4822 462 40869	LEG	153T057000					
060F			REAR PANEL	208N250010					
062F			SIDE PANEL R	208N249010					
064F			SIDE PANEL L	208N249020					
001G			TOP CASE K	203N064540					
002G			TOP CASE	203N064040					
003G			BUTTON	378V270420					
004G			BUTTON PLAY	378V270220					
008G		9965 000 03165	KNOB POWER	378V154260					
009G		9965 000 03165	KNOB EJECT	378V154260					
010G		4822 402 11213	RETAINER EJECT	359K104010					
012G			LEVER EJECT	203N354010					
013G		4822 492 70567	SPRING EJECT	420T115010					
014G			SPACER FOR 008G & POWER SW SY13	203N118010					
017G			CD CASE K	203N064590					
018G			CD CASE	203N064150					
019G			CD CASE WINDOW	203N158010					
020G		4822 492 11422	LEAF SPRING CD CASE	323K116010					
021G		4822 417 11351	ARM ASSY	323K002500					
022G		4822 502 21516	SCREW:1.4X2.5	022D010020					
023G		9965 000 01874	ARM ASSY+CASE	323K112010					
024G			SHAFT CD CASE	203N202010					
027G			NET SPEAKER	59069502G0					
029G			WASHER FOR BASS SW	484C056030					
034G			BUFFER FOR 001G	203N101010					
036G			SUPPORT STRAP	203N002010					
038G			ARM LASER SW	135H056020					
001M			MECHANISM VAM2103/11	208N304500					
002M		4822 402 10897	452S304500	359K056010	001S		NOT STANDARD SPARE PARTS CUSHION MAIN	208N809010	
N601			BUFFER CD MECHA	359K056010	002S		CUSHION LID	208N809020	
			SPEAKER 66MM 4Ω 5W	QK00668030	003S		PACKING CASE	208N801010	
					010S		MASTER CARTON	208N805010	

NOTE : "nsp" PART IS LISTED FOR REFERENCE ONLY, MARANTZ WILL NOT SUPPLY THESE PARTS.

11. ELECTRICAL PARTS LIST

ASSIGNMENT OF COMMON PARTS CODES.

RESISTORS

R***: 1) GD05 × × × 140, Carbon film fixed resistor, ±5% 1/4W
 R***: 2) GD05 × × × 160, Carbon film fixed resistor, ±5% 1/6W

① — Resistance value

Examples ;

① Resistance value
 0.1 Ω 001 10 Ω 100 1 kΩ 102 100 kΩ 104
 0.5 Ω 005 18 Ω 180 2.7 kΩ 272 680 kΩ 684
 1 Ω 010 100 Ω 101 10 kΩ 103 1 MΩ 105
 6.8 Ω 068 390 Ω 391 22 kΩ 223 4.7 MΩ 475

Note : Please distinguish 1/4W from 1/6W by the shape of parts used actually.

CAPACITORS

C***: CERAMIC CAP.

3) DD1 × × × × 370, Ceramic capacitor
 Disc type
 Temp.coeff.P350 ~ N1000, 50V
 ② — Capacity value
 ③ — Tolerance

Examples ;

② Tolerance (Capacity deviation)
 ±0.25 pF 0
 ±0.5 pF 1
 ±5% 5

* Tolerance of COMMON PARTS handled here are as follows :

0.5 pF ~ 5 pF ±0.25 pF
 6 pF ~ 10 pF ±0.5 pF
 12 pF ~ 560 pF ±5%

③ Capacity value



0.5 pF 005 3 pF 030 100 pF 101
 1 pF 010 10 pF 100 220 pF 221
 1.5 pF 015 47 pF 470 560 pF 561

C***: CERAMIC CAP.

4) DK16 × × × 300, High dielectric constant ceramic capacitor
 Disc type
 Temp.chara. 2B4, 50V
 ④ — Capacity value

Examples ;

④ Capacity value
 100 pF 101 1000 pF 102 10000 pF 103
 470 pF 471 2200 pF 222

C***: 5) ELECTROLY CAP. (), 6) FILM CAP. ()

5) EA × × × × × 10, Electrolytic capacitor
 One-way lead type, Tolerance ±20%
 ⑤ — Working voltage
 ⑥ — Capacity value

Examples ;

⑤ Capacity value
 0.1 μF 104 4.7 μF 475 100 μF 107
 0.33 μF 334 10 μF 106 330 μF 337
 1 μF 105 22 μF 226 1100 μF 118
 2200 μF 228

⑥ Working voltage

6.3V 006 25V 025
 10V 010 35V 035
 16V 016 50V 050

6) DF15 × × × 350 — Plastic film capacitor
 DF15 × × × 310 — One-way type, Mylar ±5% 50V
 DF16 × × × 310 — Plastic film capacitor
 One-way type, Mylar ±10% 50V
 ⑦ — Capacity value

Examples ;

⑦ Capacity value
 0.001 μF (1000 pF) 102 0.1 μF 104
 0.0018 μF 182 0.56 μF 564
 0.01 μF 103 1 μF 105
 0.015 μF 153

NOTE : 1) The above CODES (R***, R***, C***, C*** and C***) are omitted on the schematic diagram in some case.

2) On the occasion, be confirmed the common parts on the parts list.

3) Refer to "Common Parts List" for the other common parts (R105, DD4, DK4).

NOTE ON SAFETY FOR FUSIBLE RESISTOR :

The suppliers and their type numbers of fusible resistors are as follows;

1. KOA Corporation

Part No. (MJI)	Type No. (KOA)	Description
NH05 × × × 140	RF25S × × × × ΩJ	(±5% 1/4W)
NH05 × × × 120	RF50S × × × × ΩJ	(±5% 1/2W)
NH85 × × × 110	RF73B2A × × × × ΩJ	(±5% 1/10W)
NH95 × × × 140	RF73B2E × × × × ΩJ	(±5% 1/4W)

* Resistance value Resistance value
 (0.1 Ω – 10 kΩ)

2. Matsushita Electronic Components Co., Ltd

Part No. (MJI)	Type No. (MEC)	Description
NF05 × × × 140	ERD-2FCJ × × ×	(±5% 1/4W)
RF05 × × × 140	ERD-2FCG × × ×	(±2% 1/4W)
NF02 × × × 140		
RF02 × × × 140		

* Resistance value * Resistance value

Examples ;

* Resistance value
 0.1 Ω 001 10 Ω 100 1 kΩ 102 100 kΩ 104
 0.5 Ω 005 18 Ω 180 2.7 kΩ 272 680 kΩ 684
 1 Ω 010 100 Ω 101 10 kΩ 103 1 MΩ 105
 6.8 Ω 068 390 Ω 391 22 kΩ 223 4.7 MΩ 475



ABBREVIATION AND MARKS

ANT. : ANTENNA	BATT. : BATTERY
CAP. : CAPACITOR	CER. : CERAMIC
CONN. : CONNECTING	DIG. : DIGITAL
HP : HEADPHONE	MIC. : MICROPHONE
μ-PRO : MICROPROCESSOR	REC. : RECORDING
RES. : RESISTOR	SPK : SPEAKER
SW : SWITCH	TRANSF. : TRANSFORMER
TRIM. : TRIMMING	TRS. : TRANSISTOR
VAR. : VARIABLE	X'TAL : CRYSTAL

NOTE ON FUSE :

Regarding to all parts of parts code **FS20xxx2xx**, replace only with Wickmann-Werke GmbH, Type 372 non glass type fuse.

NOTE ON SAFETY :

Symbol  Fire or electrical shock hazard. Only original parts should be used to replaced any part marked with symbol . Any other component substitution (other than original type), may increase risk of fire or electrical shock hazard.

安全上の注意 :

 がついている部品は、安全上重要な部品です。必ず指定されている部品番号の部品を使用して下さい。

POS. NO	VERS. COLOR	PART NO. (FOR PCS)	DESCRIPTION	PART NO. (MJI)	POS. NO	VERS. COLOR	PART NO. (FOR PCS)	DESCRIPTION	PART NO. (MJI)
			P610-POWER AMP TONE ONCE MORE CIRCUIT BOARD		D681		4822 130 11513	CHIP DIODE RB161L-40 1A 40V SHOTKEY	HZ20057210
C601		4822 124 11074	ELECT. CHIP 10µF 16V	EY10601620	Q601			IC BH3852FS TONE IC	HC10219210
C602		4822 124 11074	ELECT. CHIP 10µF 16V	EY10601620	Q620			IC 74HC123 CMOS	HC712300Z0
C603					Q621			CHIP TRS. 2SC4081 Q R	HX300012A0
C606			CER. CHIP 0.015µF ±10% X7R 16V W5R	DK96153200	Q622			2SC4116 Y GR	
C607		4822 126 12846	CER. CHIP 0.012µF ±10%	DK96123200				CHIP TRS. 2SC4081 Q R	HX300012A0
C608		4822 126 12846	CER. CHIP 0.012µF ±10%	DK96123200	Q650			2SC4116 Y GR	
C609		4822 124 11074	ELECT. CHIP 10µF 16V	EY10601620	Q651			TRS. 2SA1859 Y	HT118591B0
C610		4822 124 11074	ELECT. CHIP 10µF 16V	EY10601620	Q680		4822 209 17378	IC LA4192 POWER AMP	HC10410030
C611		4822 126 11687	CER. CHIP 0.1µF	DK98104200				IC PQ30RV2	HC31930320
C612		4822 124 11074	ELECT. CHIP 10µF 16V	EY10601620				P610-MISCELLANEOUS	
C613		4822 126 13837	CER. CHIP 0.1µF ±10% B 10V	DK96104200	H601		4822 511 61013	HEATSINK	309V267010
C614		4822 126 13837	CER. CHIP 0.1µF ±10% B 10V	DK96104200	J650			JACK S2B-PH-SM3-TB PH 2P	YJ07018520
C615		4822 124 11074	ELECT. CHIP 10µF 16V	EY10601620				PC10-LCD CIRCUIT BOARD	
C616		4822 126 11687	CER. CHIP 0.1µF	DK98104200				PC10-CAPACITORS	
C617		4822 124 11432	ELECT. CHIP 100µF 10V	EY10701020	CC01		4822 124 11432	ELECT. CHIP 100µF 10V	EY10701020
C620		4822 126 11687	CER. CHIP 0.1µF	DK98104200	CC02		4822 124 11229	ELECT. CHIP 4.7µF 35V	EY47503520
C623			ELECT. CHIP 470µF 10V	EY47701020	CC03		4822 124 11229	ELECT. CHIP 4.7µF 35V	EY47503520
C624		4822 124 11074	ELECT. CHIP 10µF 16V	EY10601620	CC04		4822 124 11074	ELECT. CHIP 10µF 16V	EY10601620
C625		9965 000 01438	ELECT. CHIP 2.2µF 50V	EY22505020	CC05		4822 124 11074	ELECT. CHIP 10µF 16V	EY10601620
C651		4822 126 11687	CER. CHIP 0.1µF	DK98104200	CC06		4822 126 11687	CER. CHIP 0.1µF	DK98104200
C652		4822 124 11074	ELECT. CHIP 10µF 16V	EY10601620	CC07		4822 126 11687	CER. CHIP 0.1µF 50V	DK98104200
C654					CC08		4822 126 11687	CER. CHIP 0.1µF 50V	DK98104200
C657		4822 124 11432	ELECT. CHIP 100µF 10V	EY10701020	CC10				
C658			CER. CHIP 0.15µF ±10% B 10V	DK96154200			4822 126 13883	CER. CHIP 220pF ±5% 50V	DD95221300
C659			CER. CHIP 0.15µF ±10% B 10V	DK96154200	CC13				
C660			ELECT. CHIP 470µF 10V	EY47701020				PC10-CAPACITORS (COMMON)	
C661			ELECT. CHIP 470µF 10V	EY47701020	***			ELECTROLYTIC CAPACITOR ±20% : CC14	
C663		5322 126 11578	CER. CHIP 1000pF ±10% B 50V	DK96102300				PC10-RESISTORS	
C664		4822 126 14417	CER. CHIP 0.01µF ±10% 50V C1608JB1H103K	DK96103300	RC01		4822 116 83207	CHIP 1.2kΩ ±5% 1/16W	NN05122610
C665		4822 126 11687	CER. CHIP 0.1µF	DK98104200	RC02		4822 051 30332	CHIP 3.3kΩ ±5% 1/16W	NN05332610
C666		4822 126 11687	CER. CHIP 0.1µF	DK98104200	RC03		4822 051 30682	CHIP 6.8kΩ ±5% 1/16W	NN05682610
C668		4822 126 12339	CER. CHIP 2200pF GR39	DK96222300	RC04		4822 051 30223	CHIP 22kΩ ±5% 1/16W	NN05223610
C669		4822 126 12339	CER. CHIP 2200pF GR39	DK96222300	RC05				
C670			ELECT. 1500µF 16V ±20% SMG	EA15801680			4822 116 83213	CHIP 270Ω ±5% 1/16W	NN05271610
C681		4822 124 11432	ELECT. CHIP 100µF 10V	EY10701020	RC08				
C682		4822 126 11687	CER. CHIP 0.1µF	DK98104200	RC09		4822 051 30683	CHIP 68kΩ ±5% 1/16W	NN05683610
C684		4822 126 11687	CER. CHIP 0.1µF	DK98104200	RC10		4822 051 30822	CHIP 8.2kΩ ±5% 1/16W	NN05822610
			P610-CAPACITORS (COMMON)		RC11		4822 051 30101	CHIP 100Ω ±5% 1/16W	NN05101610
			ELECTROLYTIC CAPACITOR ±20% : C650 C653 C662		RC12		4822 051 30104	CHIP 100kΩ ±5% 1/16W	NN05104610
			P610-RESISTORS		RC13				
R620		4822 051 30473	CHIP 47kΩ ±5% 1/16W	NN05473610			4822 051 30101	CHIP 100Ω ±5% 1/16W	NN05101610
R622		4822 051 30103	CHIP 10kΩ ±5% 1/16W	NN05103610	RC23				
R623		4822 051 30103	CHIP 10kΩ ±5% 1/16W	NN05103610	RC30		4822 116 83819	CHIP 18kΩ ±5% 1/16W	NN05183610
R625		4822 051 30472	CHIP 4.7kΩ ±5% 1/16W	NN05472610	RC31		4822 051 30332	CHIP 3.3kΩ ±5% 1/16W	NN05332610
R626		4822 051 30472	CHIP 4.7kΩ ±5% 1/16W	NN05472610	RC32		4822 116 83819	CHIP 18kΩ ±5% 1/16W	NN05183610
R627		4822 116 83819	CHIP 18kΩ ±5% 1/16W	NN05183610	RC33		4822 051 30332	CHIP 3.3kΩ ±5% 1/16W	NN05332610
R652		4822 116 83211	CHIP 1.8kΩ ±5% 1/16W	NN05182610	RC34		4822 116 83819	CHIP 18kΩ ±5% 1/16W	NN05183610
R653		4822 051 30391	CHIP 390Ω ±5% 1/16W	NN05391610				PC10-SEMICONDUCTORS	
R654		4822 051 30221	CHIP 220Ω ±5% 1/16W	NN05221610	DC03			L.E.D. NSCW215	HI10003980
R655		4822 051 30478	CHIP 4.7kΩ ±5% 1/16W	NN05047610	DC05		4822 130 11515	PHOTO UNIT RPM6936	HW10005210
R656		4822 051 30472	CHIP 4.7kΩ ±5% 1/16W	NN05472610				IR RECEIVER 36KHZ	
R657		4822 051 30181	CHIP 180Ω ±5% 1/16W	NN05181610	QC01		9965 000 03095	IC NJU6428CF-G1-02	HC10177090
R658		4822 051 30829	CHIP 82Ω ±5% 1/16W	NN05820610				PC10-MISCELLANEOUS	
R680		4822 051 30391	CHIP 390Ω ±5% 1/16W	NN05391610	JC01			JACK 24FMN-BMT-TF	YJ07020740
R681		4822 051 30222	CHIP 2.2kΩ ±5% 1/16W	NN05222610	VC01		9965 000 03097	DISPLAY UNIT LM-1658B	HQ21901860
			P610-SEMICONDUCTORS					LCD PANEL	
D680			CHIP DIODE 30BQ100	HZ20001990				PF02-VOL CIRCUIT BOARD	
			SCHOTTKY 100 V 3A		RH05		9965 000 03139	VAR. 10K B RK0972220	RM01031140

NOTE : "nsp" PART IS LISTED FOR REFERENCE ONLY, MARANTZ WILL NOT SUPPLY THESE PARTS.

POS. NO	VERS. COLOR	PART NO. (FOR PCS)	DESCRIPTION	PART NO. (MJI)	POS. NO	VERS. COLOR	PART NO. (FOR PCS)	DESCRIPTION	PART NO. (MJI)
CD19			TANTL. CHIP 10μF 10V	EY10601070	CP01		4822 126 11687	CER. CHIP 0.1μF	DK98104200
CD20			TANTL. CHIP 1μF 35V	EY10503570	CP02		4822 126 12503	CER. CHIP 0.033μF +80% -20%	DK98333200
CD21		4822 126 12061	CER. CHIP 0.1μF	DK56104200	CP03		4822 126 11687	CER. CHIP 0.1μF	DK98104200
CD22					CP04		4822 126 11687	CER. CHIP 0.1μF	DK98104200
CD25		4822 122 33741	CER. CHIP 10pF ±0.5pF	DD91100300	CP05		4822 126 11687	CER. CHIP 0.1μF	DK98104200
CD26			CH 50V GR39		CP07			TANTL. CHIP 10μF10V	EY10601070
CD27			ELECT. CHIP 470μF 10V	EY47701020	CP08		9965 000 03905	TANTL. CHIP 47μF 16V	EY47601030
CD28		4822 126 11687	CER. CHIP 0.1μF	DK98104200	CP09		4822 124 81234	TANTL. CHIP 220μF 6.3V	EY22700690
CD29		4822 124 11432	ELECT. CHIP 100μF 10V	EY10701020	CR03		4822 126 11759	CER. CHIP 100 pF	DD95101300
CD30		4822 124 11432	ELECT. CHIP 100μF 10V	EY10701020	CR04		4822 126 11759	CER. CHIP 100 pF	DD95101300
CD33					CR10		4822 126 11687	CER. CHIP 0.1μF	DK98104200
CD34		4822 126 11568	CER. CHIP 470pF GR39	DK96471300	CR11			TANTL. CHIP 10μF 10V	EY10601070
CD35		5322 126 11578	CER. CHIP 1000pF ±10% B 50V	DK96102300	CS01		4822 124 11432	ELECT. CHIP 100μF 10V	EY10701020
CD36		4822 126 11568	CER. CHIP 470pF GR39	DK96471300	CS02			TANTL. CHIP 1μF 35V	EY10503570
CD37		5322 126 11578	CER. CHIP 1000pF ±10% B 50V	DK96102300	CS04		4822 126 11687	CER. CHIP 0.1μF	DK98104200
CD38		4822 126 11687	CER. CHIP 0.1μF	DK98104200	CS05		4822 122 33752	CER. CHIP 15 pF	DD95150300
CD39		4822 124 11432	ELECT. CHIP 100μF 10V	EY10701020	CS06		9965 000 01912	CER. CHIP 0.047μF	DK98473300
CD40		4822 126 11687	CER. CHIP 0.1μF	DK98104200	CS07		4822 126 11703	CER. CHIP 0.01μF	DK98103300
CD41		4822 124 81234	TANTL. CHIP 220μF6.3V	EY22700690	CS08			TANTL. CHIP 1μF 35V	EY10503570
CD43		4822 126 11687	CER. CHIP 0.1μF	DK98104200	CS09		4822 126 11687	CER. CHIP 0.1μF	DK98104200
CD44		4822 124 11432	ELECT. CHIP 100μF10V	EY10701020	CS10		5322 126 11578	CER. CHIP 1000pF	DK96102300
CD45					CS11		4822 122 33777	CER. CHIP 47pF ±5% CG 50V	DD95470300
CD48		4822 126 11687	CER. CHIP 0.1μF	DK98104200	CS12			TANTL. CHIP 1μF 35V	EY10503570
CD50		9965 000 01912	CER. CHIP 47μF	DK98473300	CS13			TANTL. CHIP 1μF 35V	EY10503570
CD51		9965 000 01912	CER. CHIP 0.047μF	DK98473300	CS14				
CD52		4822 126 12061	CER. CHIP 0.1μF	DK56104200	CS19		4822 126 13883	CER. CHIP 220pF ±5% CG 50V GR39	DD95221300
CK01		4822 124 11074	ELECT. CHIP 10μF 16V	EY10601620	CS20			TANTL. CHIP 1μF 35V	EY10503570
CK02		4822 124 11074	ELECT. CHIP 10μF 16V	EY10601620	CS21			TANTL. CHIP 1μF 35V	EY10503570
CK03		4822 126 13883	CER. CHIP 220pF ±5% CG 50V	DD95221300	CS22		4822 126 11687	CER. CHIP 0.1μF	DK98104200
CK04		4822 126 13883	CER. CHIP 220pF ±5% CG 50V	DD95221300	CS23			TANTL. CHIP 1μF 35V	EY10503570
CK05		4822 122 33751	CER. CHIP 120pF GR39	DD95121300	CS25		4822 126 11687	CER. CHIP 0.1μF	DK98104200
CK06		4822 122 33751	CER. CHIP 120pF GR39	DD95121300	CS26			TANTL. CHIP 0.47μF 16V	EY47401670
CK07		4822 124 11074	ELECT. CHIP 10μF 16V	EY10601620	CS27			CER. CHIP 1pF ±0.25pF 50V	DD90010300
CK08		4822 124 11074	ELECT. CHIP 10μF 16V	EY10601620	CS28		4822 126 11669	CER. CHIP 27pF	DD95270300
CK13		4822 126 13883	CER. CHIP 220pF ±5% 50V	DD95221300	CS29		4822 126 11671	CER. CHIP 33pF	DD95330300
CK14		4822 126 13883	CER. CHIP 220pF ±5%	DD95221300	CS30		4822 126 11671	CER. CHIP 33pF	DD95330300
CK25		4822 126 11687	CER. CHIP 0.1μF	DK98104200	CS31		4822 122 33761	CER. CHIP 22pF ±5% CG 50V	DD95220300
CK26		4822 126 11687	CER. CHIP 0.1μF	DK98104200	CU01		4822 126 11663	CER. CHIP 12pF ±5% CG 50V	DD95120300
CK27			TANTL. CHIP 1μF 35V	EY10503570	CU02		4822 126 11663	CER. CHIP 12pF ±5% CG 50V	DD95120300
CK28					CU03		5322 126 11578	CER. CHIP 1000pF ±10% B 50V	DK96102300
CK33		4822 126 11687	CER. CHIP 0.1μF	DK98104200	CU04			TANTL. CHIP 1μF 35V	EY10503570
CK34		4822 126 11661	CER. CHIP 5pF ±0.25pF 50V	DD90050300	CU05		4822 126 11687	CER. CHIP 0.1μF	DK98104200
CK35		4822 126 11661	CER. CHIP 5pF ±0.25pF 50V	DD90050300	CU06			TANTL. CHIP 10μF 10V	EY10601070
CK36		4822 126 11687	CER. CHIP 0.1μF	DK98104200	CU07		4822 126 11759	CER. CHIP 100pF ±5% CG 50V GR39	DD95101300
CK37		4822 126 11687	CER. CHIP 0.1μF	DK98104200	CU11				
CK38		4822 126 11687	CER. CHIP 0.1μF	DK98104200	CU12		4822 126 11759	CER. CHIP 100pF	DD95101300
CK39		9965 000 03911	TANTL. CHIP 10μF16V	EY10601670	CU15		4822 126 11759	CER. CHIP 100pF ±5% CG 50V	DD95101300
CK41					CU16		4822 126 11687	CER. CHIP 0.1μF	DK98104200
CK44		5322 126 11578	CER. CHIP 1000pF	DK96102300	CU17		4822 126 11687	CER. CHIP 0.1μF	DK98104200
CK45		4822 122 33777	CER. CHIP 47pF ±5%	DD95470300					
CK46		4822 122 33777	CER. CHIP 47pF ±5%	DD95470300					
CL03		4822 126 13396	CER. CHIP 0.047μF ±10% 16V	DK96473200					
CL04			TANTL. CHIP 10μF 10V	EY10601070					
CL05		4822 122 33761	CER. CHIP 22pF 50V	DD95220300					
CL06		4822 126 13396	CER. CHIP 0.047μF ±10% 16V	DK96473200					
CL07			TANTL. CHIP 10μF 10V	EY10601070					
CL10			TANTL. CHIP 10μF 10V	EY10601070					
CL11		4822 126 13396	CER. CHIP 0.047μF ±10% 16V	DK96473200					
CL12		4822 126 13396	CER. CHIP 0.047μF ±10% 16V	DK96473200					
CL13			TANTL. CHIP 10μF 10V	EY10601070					
CL14		4822 126 12339	CER. CHIP 2200pF GR39	DK96222300					
CL15		4822 126 12339	CER. CHIP 2200pF GR39	DK96222300					
								PM06-RESISTORS	
					RD01		4822 051 30223	CHIP 22kΩ ±5% 1/16W	NN05223610
					RD02		4822 051 30102	CHIP 1kΩ ±5% 1/16W	NN05102610
					RD03		4822 051 30103	CHIP 10kΩ ±5% 1/16W	NN05103610
					RD04		4822 051 30103	CHIP 10kΩ ±5% 1/16W	NN05103610
					RD05		4822 051 30273	CHIP 27kΩ ±5% 1/16W	NN05273610
					RD06		4822 051 30682	CHIP 6.8kΩ ±5% 1/16W	NN05682610
					RD07		9965 000 03187	CHIP 56Ω ±5% 1/16W	NN05560610
					RD08		4822 051 30104	CHIP 100kΩ ±5% 1/16W	NN05104610
					RD11		4822 051 30154	CHIP 150kΩ ±5% 1/16W	NN05154610
					RD12		4822 117 12139	CHIP 22Ω ±5% 1/16W	NN05220610
					RD13		4822 051 30272	CHIP 2.7kΩ ±5% 1/16W	NN05272610
					RD15		4822 051 30102	CHIP 1kΩ ±5% 1/16W	NN05102610
					RD16		9965 000 03187	CHIP 56Ω ±5% 1/16W	NN05560610
					RD17		4822 100 11787	TRIMM. 1kΩ	NY01020160
								EVM1S/TMC3KB/RH03AD	

NOTE : "nsp" PART IS LISTED FOR REFERENCE ONLY, MARANTZ WILL NOT SUPPLY THESE PARTS.

POS. NO	VERS. COLOR	PART NO. (FOR PCS)	DESCRIPTION	PART NO. (MUJ)	POS. NO	VERS. COLOR	PART NO. (FOR PCS)	DESCRIPTION	PART NO. (MUJ)
RD18		4822 051 30103	CHIP 10kΩ ±5% 1/16W	NN05103610	RL10		4822 051 30103	CHIP 10kΩ ±5% 1/16W	NN05103610
RD19		4822 051 30223	CHIP 22kΩ ±5% 1/16W	NN05223610	RL11		4822 051 30103	CHIP 10kΩ ±5% 1/16W	NN05103610
RD20		4822 051 30103	CHIP 10kΩ ±5% 1/16W	NN05103610	RL12		4822 051 30103	CHIP 10kΩ ±5% 1/16W	NN05103610
RD21		4822 051 30223	CHIP 22kΩ ±5% 1/16W	NN05223610	RL13		4822 051 30221	CHIP 220Ω ±5% 1/16W	NN05221610
RD22		4822 116 83215	CHIP 5.6kΩ ±5% 1/16W	NN05562610	RL14		4822 051 30221	CHIP 220Ω ±5% 1/16W	NN05221610
RD23		4822 051 30153	CHIP 15kΩ ±5% 1/16W	NN05153610	RL15		4822 051 30221	CHIP 220Ω ±5% 1/16W	NN05221610
RD24		4822 051 30472	CHIP 4.7kΩ ±5% 1/16W	NN05472610	RL16		4822 051 30478	CHIP 4.7Ω ±5% 1/16W	NN05047610
RD25		4822 051 30223	CHIP 22kΩ ±5% 1/16W	NN05223610	RL18		4822 116 82487	CHIP 0Ω	NN05000610
RD26		4822 051 30471	CHIP 470Ω ±5% 1/16W	NN05471610					
RD27		4822 051 30109	CHIP 10Ω ±5% 1/16W	NN05100610	RP02		4822 117 12139	CHIP 22Ω ±5% 1/16W	NN05220610
RD28		4822 051 30109	CHIP 10Ω ±5% 1/16W	NN05100610	RP04		4822 051 30103	CHIP 10kΩ ±5% 1/16W	NN05103610
RD29		4822 051 30109	CHIP 10Ω ±5% 1/16W	NN05100610	RP05		4822 051 30103	CHIP 10kΩ ±5% 1/16W	NN05103610
RD30		4822 051 30822	CHIP 8.2kΩ ±5% 1/16W	NN05822610	RP06		4822 117 12139	CHIP 22Ω ±5% 1/16W	NN05220610
RD31		4822 051 30332	CHIP 3.3kΩ ±5% 1/16W	NN05332610	RP07		4822 116 82487	CHIP 0Ω ±5% 1/16W	NN05000610
RD32		4822 051 30103	CHIP 10kΩ ±5% 1/16W	NN05103610	RP09		4822 051 30333	CHIP 33kΩ	NN05333610
RD33		4822 051 30272	CHIP 2.7kΩ ±5% 1/16W	NN05272610	RP10		4822 051 30223	CHIP 22kΩ	NN05223610
RD34		4822 116 83215	CHIP 5.6kΩ ±5% 1/16W	NN05562610	RP11		4822 116 82487	CHIP 0Ω	NN05000610
RD35		4822 051 30103	CHIP 10kΩ ±5% 1/16W	NN05103610	RP12		4822 116 82487	CHIP 0Ω ±5% 1/16W	NN05000610
RD36		4822 051 30272	CHIP 2.7kΩ ±5% 1/16W	NN05272610	RP13				
RD38		4822 051 30103	CHIP 10kΩ ±5% 1/16W	NN05103610	}		4822 051 30561	CHIP 560Ω ±5% 1/16W	NN05561610
RD39		4822 051 30103	CHIP 10kΩ ±5% 1/16W	NN05103610	RP17				
RD40		4822 051 30478	CHIP 4.7Ω ±5% 1/16W	NN05047610	RP18		4822 051 30561	CHIP 560Ω ±5% 1/16W	NN05561610
RD41		4822 111 91414	CHIP 10Ω ±5% 1/10W	NI05100110	RR03		4822 051 30392	CHIP 3.9kΩ ±5% 1/16W	NN05392610
RD42		4822 111 91461	CHIP 680kΩ ±5% 1/10W	NI05684110	RR08		4822 051 30392	CHIP 3.9kΩ ±5% 1/16W	NN05392610
RD43		4822 111 90914	CHIP 330kΩ ±5% 1/10W	NI05334110					
RD44		4822 116 82487	CHIP 0 OH ±5% 1/16W	NN05000610	RS01		4822 051 30223	CHIP 22kΩ ±5% 1/16W	NN05223610
					RS04		4822 051 30478	CHIP 4.7Ω ±5% 1/16W	NN05047610
RK01		4822 116 83819	CHIP 18kΩ ±5% 1/16W	NN05183610	RS05		4822 051 30223	CHIP 22kΩ ±5% 1/16W	NN05223610
RK02		4822 116 83819	CHIP 18kΩ ±5% 1/16W	NN05183610	RS06		4822 051 30102	CHIP 1kΩ ±5% 1/16W	NN05102610
RK03		4822 051 30393	CHIP 39kΩ ±5% 1/16W	NN05393610	RS07		4822 051 30478	CHIP 4.7Ω ±5% 1/16W	NN05047610
RK04		4822 051 30393	CHIP 39kΩ ±5% 1/16W	NN05393610	RS08		4822 051 30333	CHIP 33kΩ ±5% 1/16W	NN05333610
RK05		4822 116 83819	CHIP 18kΩ ±5% 1/16W	NN05183610	RS09				
RK06		4822 116 83819	CHIP 18kΩ ±5% 1/16W	NN05183610	}		4822 051 30103	CHIP 10kΩ ±5% 1/16W	NN05103610
RK07		4822 051 30472	CHIP 4.7kΩ ±5% 1/16W	NN05472610	RS14				
RK08		4822 051 30472	CHIP 4.7kΩ ±5% 1/16W	NN05472610	RS16		4822 051 30473	CHIP 47kΩ ±5% 1/16W	NN05473610
RK09		4822 051 30105	CHIP 1MΩ ±5% 1/16W	NN05105610	RS17		4822 051 30102	CHIP 1kΩ ±5% 1/16W	NN05102610
RK10		4822 051 30105	CHIP 1MΩ ±5% 1/16W	NN05105610	RS19		4822 051 30223	CHIP 22kΩ ±5% 1/16W	NN05223610
RK13					RS20		4822 051 30223	CHIP 22kΩ ±5% 1/16W	NN05223610
}		4822 116 83208	CHIP 12kΩ ±5% 1/16W	NN05123610	RS21		4822 051 30223	CHIP 22kΩ ±5% 1/16W	NN05223610
RK18					RS22		4822 051 30103	CHIP 10kΩ ±5% 1/16W	NN05103610
RK35					RS23		4822 051 30102	CHIP 1kΩ ±5% 1/16W	NN05102610
}		4822 051 30109	CHIP 10Ω ±5% 1/16W	NN05100610	RS24		4822 051 30478	CHIP 4.7Ω ±5% 1/16W	NN05047610
RK38					RS25		4822 116 83215	CHIP 5.6kΩ ±5% 1/16W	NN05562610
RK40					RS26		4822 051 30273	CHIP 27kΩ ±5% 1/16W	NN05273610
}		4822 051 30109	CHIP 10Ω ±5% 1/16W	NN05100610	RS27		4822 117 12139	CHIP 22Ω ±5% 1/16W	NN05220610
RK43					RS28				
RK44		4822 051 30472	CHIP 4.7kΩ ±5% 1/16W	NN05472610	}		4822 116 82487	CHIP 0Ω ±5% 1/16W	NN05000610
RK45		4822 051 30472	CHIP 4.7kΩ ±5% 1/16W	NN05472610	RS32				
RK46		4822 051 30223	CHIP 22kΩ ±5% 1/16W	NN05223610	RS33		4822 051 30109	CHIP 10Ω ±5% 1/16W	NN05100610
RK50		4822 116 82487	CHIP 0Ω ±5% 1 / 16W	NN05000610					
RK56		4822 051 30103	CHIP 10kΩ	NN05103610	RU02		4822 051 30223	CHIP 22kΩ ±5% 1/16W	NN05223610
RK57		4822 051 30103	CHIP 10kΩ	NN05103610	RU03		4822 051 30102	CHIP 1kΩ ±5% 1/16W	NN05102610
RK58		4822 051 30223	CHIP 22kΩ	NN05223610	RU04		4822 051 30105	CHIP 1MΩ ±5% 1/16W	NN05105610
RK59		4822 051 30223	CHIP 22kΩ	NN05223610	RU05		4822 051 30103	CHIP 10kΩ ±5% 1/16W	NN05103610
RK60		4822 051 30103	CHIP 10kΩ	NN05103610	RU06		4822 051 30473	CHIP 47kΩ ±5% 1/16W	NN05473610
RK61		4822 051 30103	CHIP 10kΩ	NN05103610	RU07		4822 051 30332	CHIP 3.3kΩ ±5% 1/16W	NN05332610
RK62		4822 051 30223	CHIP 22kΩ	NN05223610	RU08		4822 051 30473	CHIP 47kΩ ±5% 1/16W	NN05473610
RK63		4822 051 30223	CHIP 22kΩ	NN05223610	RU09		4822 051 30472	CHIP 4.7kΩ ±5% 1/16W	NN05472610
RK64		4822 051 30102	CHIP 1kΩ ±5% 1/16W	NN05102610	RU11				
RK65		4822 051 30103	CHIP 10kΩ ±5% 1/16W	NN05103610	}		4822 051 30101	CHIP 100Ω ±5% 1/16W	NN05101610
RK66		4822 051 30109	CHIP 10Ω ±5% 1/16W	NN05100610	RU17				
RK67		4822 051 30109	CHIP 10 OHN ±5% 1/16W	NN05100610	RU18		4822 051 30223	CHIP 22kΩ ±5% 1/16W	NN05223610
RK68		4822 051 30472	CHIP 4.7kΩ ±5% 1/16W	NN05472610	RU19		4822 051 30103	CHIP 10kΩ ±5% 1/16W	NN05103610
RK69		4822 051 30109	CHIP 10Ω ±5% 1/16W	NN05100610	RU20		4822 051 30223	CHIP 22kΩ ±5% 1/16W	NN05223610
					RU21		4822 051 30223	CHIP 22kΩ ±5% 1/16W	NN05223610
RL05		4822 116 81008	CHIP 4.7Ω ±5% 1 / 10W	NI05047110	RU22		4822 051 30223	CHIP 22kΩ ±5% 1/16W	NN05223610
RL06		4822 051 30681	CHIP 680Ω ±5% 1/16W	NN05681610	RU24		4822 051 30103	CHIP 10kΩ ±5% 1/16W	NN05103610
RL07		4822 051 30478	CHIP 4.7Ω ±5% 1/16W	NN05047610	RU25		4822 051 30109	CHIP 10Ω ±5% 1/16W	NN05100610
RL08		4822 051 30221	CHIP 220Ω ±5% 1/16W	NN05221610	RU27		4822 051 30399	CHIP 39Ω ±5% 1/16W	NN05390610
RL09		4822 051 30221	CHIP 220Ω ±5% 1/16W	NN05221610	RU28		4822 051 30103	CHIP 10kΩ ±5% 1/16W	NN05103610

NOTE : "nsp" PART IS LISTED FOR REFERENCE ONLY, MARANTZ WILL NOT SUPPLY THESE PARTS.

POS. NO	VERS. COLOR	PART NO. (FOR PCS)	DESCRIPTION	PART NO. (MJI)	POS. NO	VERS. COLOR	PART NO. (FOR PCS)	DESCRIPTION	PART NO. (MJI)
RU31		4822 051 30473	CHIP 47kΩ ±5% 1/16W	NN05473610	LD01		4822 157 71068	CHIP INDUCTANCE	LU22473040
RU32		4822 051 30103	CHIP 10kΩ ±5% 1/16W	NN05103610	LD02		4822 157 11808	LQH3N470K34 47μH 100MA CHIP FERRITE CORE	FC90020110
RU64		4822 116 82487	CHIP 0Ω	NN05000610	LD03		4822 526 10715	BLM11B601S	FN21020010
RU68		4822 116 82487	CHIP 0Ω	NN05000610	LD06		4822 157 11811	EMI ACM4532-601-2P-T COMMON MODE	FN21020010
RU72		4822 116 82487	CHIP 0Ω	NN05000610	LD07		4822 157 11811	CHIP INDUCTANCE CMD-8R TRANS.FOR DC DC 17μH	LU80173010
RU80		4822 116 82487	CHIP 0Ω	NN05000610	LD08		4822 157 11811	CHIP INDUCTANCE CR54 POWER INDUCTOR 47μH	LU83473020
RU82		4822 116 82487	CHIP 0Ω	NN05000610	LD08		4822 157 11811	CHIP INDUCTANCE CR54 POWER INDUCTOR 47μH	LU83473020
RU89		4822 116 82487	CHIP 0Ω	NN05000610	LS01		4822 157 11808	CHIP FERRITE CORE	FC90020110
RU91		4822 116 82487	CHIP 0Ω	NN05000610	SU01		4822 276 13868	BLM11B61S PUSH SWITCH DETECT	SP01012420
RU98		4822 116 82487	CHIP 0Ω	NN05000610	XK01		4822 242 81864	ESE11SV1 CRYSTAL X'TAL 33.8688MHz	JX33001350
DD01		4822 130 11513	PM06-SEMICONDUCTORS CHIP DIODE RB161L-40 1A 40V SHOTKEY	HZ20057210	XS01		4822 242 81864	CRYSTAL 8MHz	JX08001320
DD03		4822 130 11513	CHIP DIODE RB161L-40 1A 40V SHOTKEY	HZ20057210	XU01		4822 242 81864	CRYSTAL 10MHz	JX10007320
DD04		4822 130 10092	CHIP DIODE DIF60-4063	HZ20001290	CM02		4822 126 11687	PM10-DC TERMINAL CIRCUIT BOARD CER. CHIP 0.1μF	DK98104200
DD05		4822 130 83715	CHIP DIODE 1SS301 DAN202U	HZ21005000	CM14		4822 126 13909	CER. CHIP 680pF GR39	DK96681300
DD06		4822 130 83231	CHIP DIODE 02CZ3.6X	HZ30018050	CM16		4822 126 11687	CER. CHIP 0.1μF	DK98104200
DD07		4822 130 11514	CHIP DIODE 02CZ4.7Z	HZ30017050	DM02		4822 130 80326	L.E.D. FIP52BW13Y	HI10062320
QD01		4822 209 17196	IC BA6893AK 4CH DRIVER WITH DC DC	HC10198210	JM04		4822 130 80326	DC JACK EIAJ TYPE 3 HEC3100	YJ04002530
QD02		4822 209 17196	CHIP TRS. 2SC4081 Q R 2SC4116 Y GR	HX300012A0	RM02		4822 051 30391	CHIP 390Ω ±5% 1/16W	NN05391610
QD03		4822 209 17196	CHIP TRS. 2SC4081 Q R 2SC4116 Y GR	HX300012A0	WC01		4822 051 30391	JUMPER LEAD JC01 - JU02	YU24210520
QD04		4822 130 11512	CHIP TRS. 2SB1302 S	HX213021B0				PV01-LINE OUT SW CIRCUIT BOARD	
QD05		4822 130 11512	TRS. 2SD1803-S	HT418031C0				PM01-CAPACITORS	
QD08		4822 130 61417	TRS. 2SB1240 TV-2 PNP Q R	HT212402A0	CG04		9965 000 01569	CER. 0.01μF 50VDC	DD38103010
QD09		4822 130 61417	TRS. 2SB1240 TV-2 PNP Q R	HT212402A0	CG05		9965 000 01569	CER. 0.01μF 50VDC	DD38103010
QD12		4822 209 61494	IC 74HC74 FLAT	HC707400Z0	CG06		4822 122 33399	CER. 1000pF Z 50V	DK18102310
QD13		4822 209 61494	IC CXD2720Q KEY CONT.	HC10067250	CG07		4822 122 33399	CER. 1000pF Z 50V	DK18102310
QK01		4822 209 14615	IC NJM2115M	HC10172090	CG08		9965 000 01569	CER. 0.01μF +80%-20% DC50V	DD38103010
QK02		4822 209 14615	IC SN74LS628NS	HC762837Z0				PV01-CAPACITORS (COMMON)	
QL02		4822 209 14615	IC MB15U10	HC10137180	C***			HIGH DIELECTRIC CONSTANT CER. CAPACITOR ±10% 50V : CG03	
QL03		4822 209 14615	IC MB15U10	HC10137180					
QP03		4822 209 14615	IC SM5904BF 44P SHOCK PROOF CONT.	HC10015350				PV01-MISCELLANEOUS	
QP04		4822 209 14615	IC TDA1545AT	HC10188490	JE02		9965 000 01316	TERMINAL YKC21-3953	YT02021500
QR01		4822 209 14615	IC NJM2115M	HC10172090	JG01		4822 290 81638	TERMINAL 14X14 RA 1L1P BL	YT02010790
QS01		4822 209 14615	IC SAA7327H MB2 CD-DECODER	HC10193490	JU01		4822 267 31132	H-P JACK O3.5 HLJ0521 FOOTPE.	YJ01003050
QS03		4822 209 14615	CHIP TRS. 2SC4081 Q R 2SC4116 Y GR	HX300012A0	LE03		4822 157 62908	CHOKE COIL 2.2 μH K	LC12223800
QS04		4822 209 32984	IC TC7SHU04F 1NV	HC10427050	LE04		4822 157 62908	CHOKE COIL 2.2 μH K	LC12223800
QU01		4822 209 32984	IC HD6473837H ONETIME KARA ROM	*HS208NH0R	LE05		4822 157 62902	CHOKE COIL 6.8μH	LC16823800
QU02		4822 130 10698	CHIP TRS. 2SA1586 Y GR 2SA1576A Q R	HX100012A0	LG02		4822 157 62908	CHOKE COIL 2.2μH J	LC12223800
QU03		4822 130 10698	CHIP TRS. 2SA1586 Y GR 2SA1576A Q R	HX100012A0	LG03		4822 157 62908	CHOKE COIL 2.2μF J	LC12223800
QU05		4822 130 10698	CHIP TRS. 2SC4081 2SC4116	HX300012A0	SV03		4822 157 62908	SLIDE SWITCH SSSF12 2-2 VOICE	SS02021690
▲ FD01		4822 265 31038	PM06-MISCELLANEOUS FUSE T2.5A 125V TE5-T NO.19396	FS20250220	S801		4822 267 31126	SLIDE SWITCH SSSF 2-2 SPEAKER	SS02021690
JK01		4822 265 31038	PLUG TKC-A 10P B TO B 10MM	YP07003900	JH01		4822 267 31126	PV02-HEAD PHONE OUT CIRCUIT BOARD ST HEADPHONE JACK GOLD	YJ01003020
JS01		4822 265 31038	JACK 18 PIN IL-402-18S-S1L-SA-E1000	YJ07006100	LH03		4822 157 62902	CHOKE COIL 6.8 μH K	LC16823800
JS04		4822 265 31038	PLUG TKC-A06P H=10MM	YP07003960	LH04		4822 157 62902	CHOKE COIL 6.8 μH K	LC16823800
JU02		4822 265 31038	JACK 24FMN-SMT-TF	YJ07026060	LH05		4822 526 10543	FERRITE CORE ZBF503AR-00 TA	FC90050090

NOTE : "nsp" PART IS LISTED FOR REFERENCE ONLY, MARANTZ WILL NOT SUPPLY THESE PARTS.

POS. NO	VERS. COLOR	PART NO. (FOR PCS)	DESCRIPTION	PART NO. (MJJ)
			PY10-KEY SW	
			CIRCUIT BOARD	
			PY10-RESISTORS	
RY01		4822 051 30223	CHIP 22k Ω \pm 5% 1/16W	NN05223610
RY02			VAR. TONE TREBLE	RK05030980
RY03			VAR. TONE BASS	RK05030980
RY04		4822 051 30682	CHIP 6.8k Ω \pm 5% 1/16W	NN05682610
RY05		4822 116 83207	CHIP 1.2k Ω \pm 5% 1/16W	NN05122610
RY06		4822 051 30223	CHIP 22k Ω \pm 5% 1/16W	NN05223610
RY07				
Y		4822 051 30273	CHIP 27k Ω \pm 5% 1/16W	NN05273610
RY10				
RY11		4822 051 30223	CHIP 22k Ω \pm 5% 1/16W	NN05223610
RY12		4822 116 83207	CHIP 1.2k Ω \pm 5% 1/16W	NN05122610
RY13		4822 116 83207	CHIP 1.2k Ω \pm 5% 1/16W	NN05122610
RY14		4822 051 30682	CHIP 6.8k Ω \pm 5% 1/16W	NN05682610
RY15		4822 051 30682	CHIP 6.8k Ω \pm 5% 1/16W	NN05682610

NOTE : "nsp" PART IS LISTED FOR REFERENCE ONLY, MARANTZ WILL NOT SUPPLY THESE PARTS.