

Service  
Service  
**Service**



**TS9500**  
**DS9500**

# Service Manual

## TABLE OF CONTENTS

	<b>Page</b>
Mechanical Instructions .....	1
Electrical diagrams .....	2
Mainboard component layout .....	3
Mechanical & Electrical Parts list .....	4
Mechanical Instructions - Docking station .....	5
Electrical diagrams - Docking station .....	6
Charge board component layout .....	7
Mechanical & Electrical Parts list - Docking station .....	8

# MECHANICAL INSTRUCTIONS - TS9500

## Set Disassembly

- 1. Remove battery lid
- 2. Remove battery
- 3. Remove 2 x screw (Torx screw 2x6)  
see picture - arrows



- 4. Put a sharp knife between toppart and bottompart  
and use this as lever to separate the two parts. see picture

Overview snavholes



# MECHANICAL INSTRUCTIONS - TS9500

## Disassembly LCD & Buttons

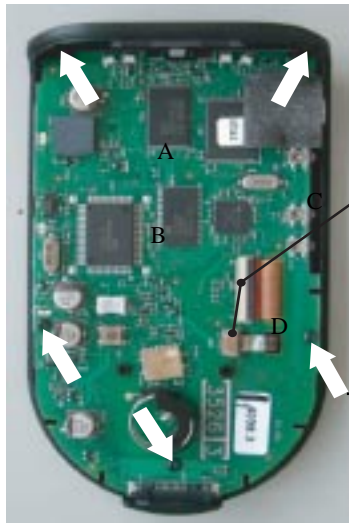

Fig. 1

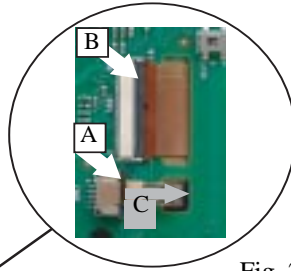
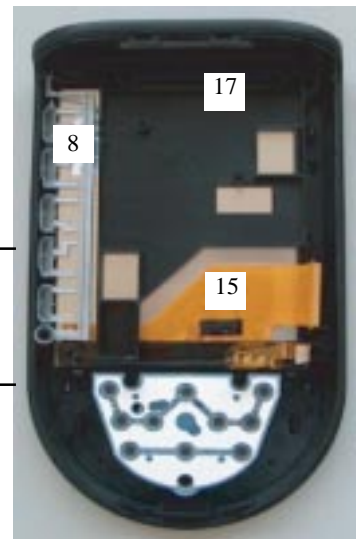

Fig. 2

1. Remove 5 x screw (Torx screw 2x6 ). see fig.1 - arrows
2. Fig.2 arrow A: Release flex cable lock in direction arrow C and remove flex
- 3 Fig.2 arrow B: Turn cable lock 90 degree and remove flex
4. Tilt the printboard assy out of cabinet.



5. Remove action keys assy item 8
6. Remove LCD support plate item 17
7. Remove LCD item 15

## Overview disassembled parts - TS9500

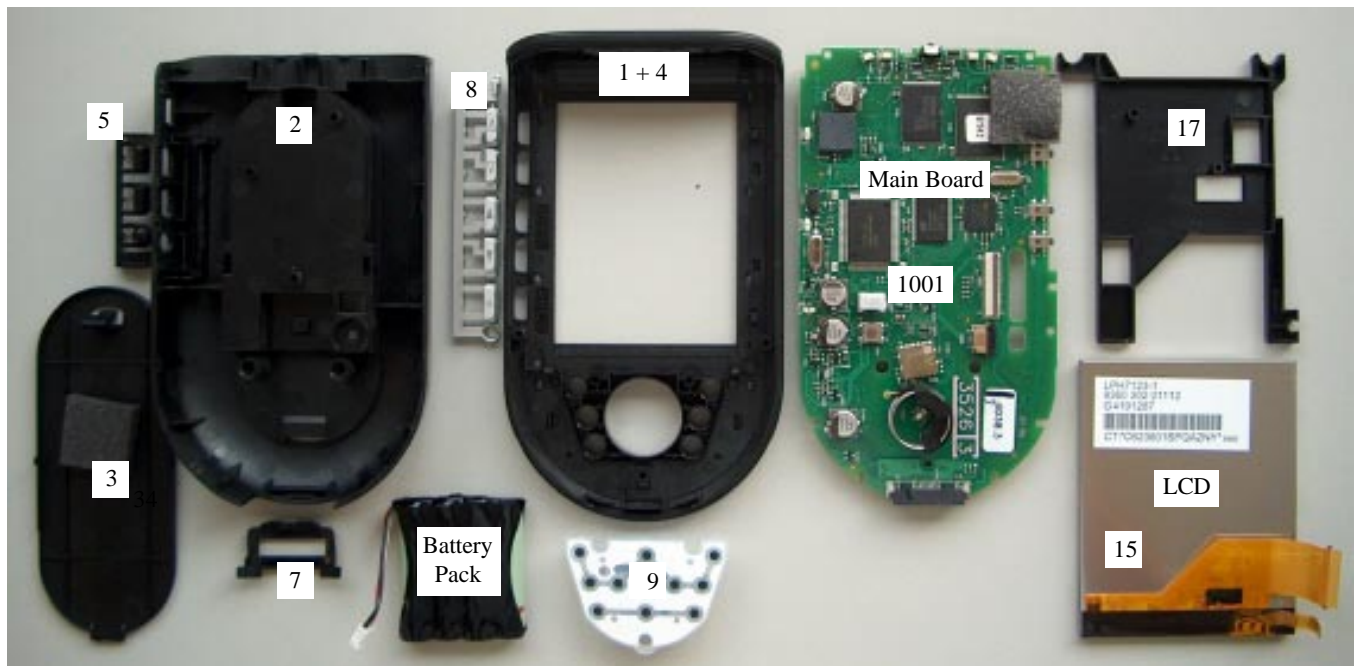

# MECHANICAL INSTRUCTIONS - TS9500

## Set Reassembly

1. Put Toppart (\*item1) and IR-wind assy (\*item 4) together.
2. Place Toppart assy (item1 & item4) upside down.
3. Place LCD assy. (\*item15)
4. Place action keys assy . (\*item8)
5. Place lower keymat assy. (\*item 9)

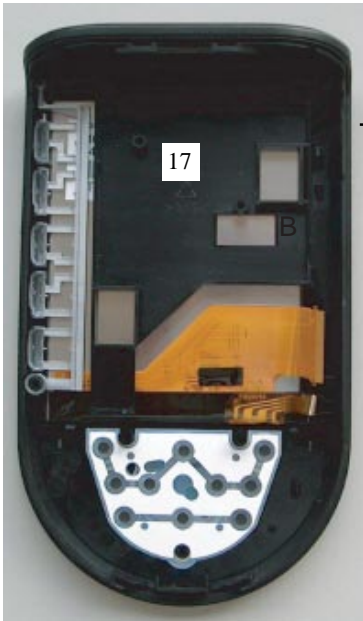
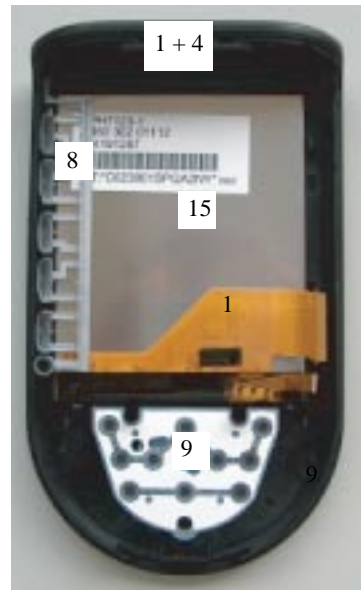

6. Place LCD support plate (\*item17)

7. Place printboard assy. (\*item1001)
8. Place Doc. plug assy. (\*item7)
9. Connect the two flex cable to the connectors and close the cable locks. see arrows A
10. Mount the 5 screws back. see arrows



11. Place the bottom part (\*item 2)
12. Mount the 2 screws
13. Place batterypack
14. Place batterylid assy. (\*item3)

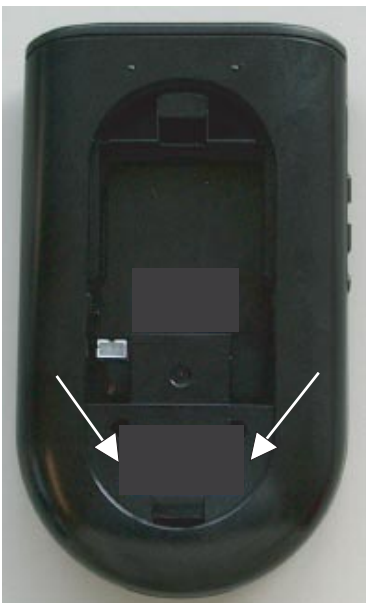

\* for items see overview disassembled parts

ELECTRICAL DIAGRAM

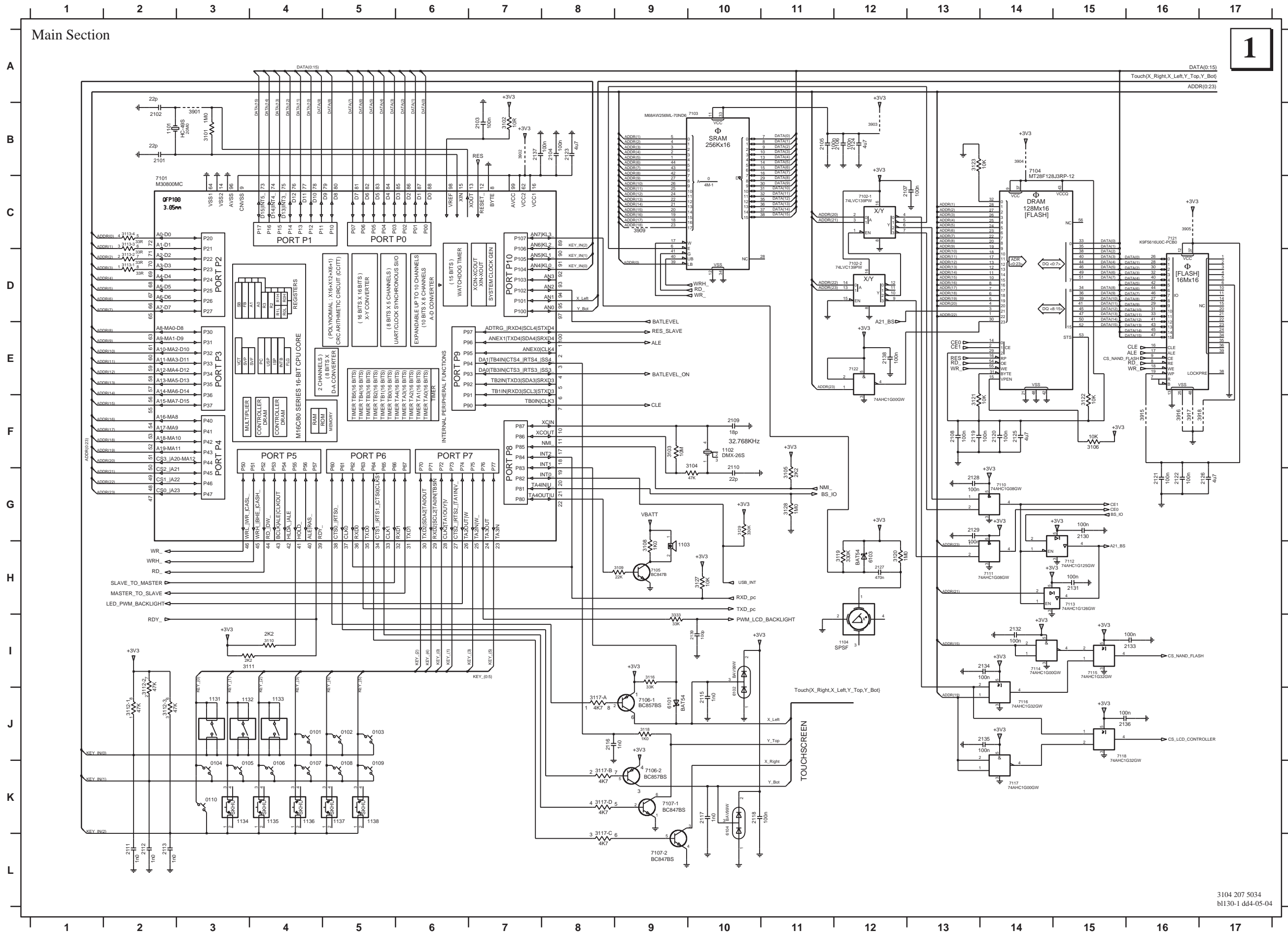

- 0101 J4 3917F-16
- 0102 J5 3918F-17
- 0103 J5 6101 J9
- 0104 J3 6102 J0
- 0105 J3 6103 H12
- 0106 J4 6104 K10
- 0107 J4 7101 E-5
- 0108 J5 7102-1 C12
- 0109 J5 7102-2 D12
- 0110 K3 7103 C10
- 1101 B2 7104 D14
- 1102F-10 7105 H9
- 1103 H9 7106-1 J9
- 1104 J2 7106-2 K9
- 1131 J3 7107-1 K9
- 1132 J3 7107-2 L-9
- 1133 J4 7110 G-14
- 1134 K3 7111 H14
- 1135 K4 7112 H15
- 1136 K4 7113 H14
- 1137 K5 7114 H-14
- 1138 K5 7115 H-15
- 2101 B2 7116 J14
- 2102 B2 7117 K14
- 2103 B7 7118 J15
- 2104 B8 7121 D16
- 2105 B11 7122 E-12
- 2106 B12
- 2107 C13
- 2108F-13
- 2109F-10
- 2110 G10
- 2111 K2
- 2112 K2
- 2113 K2
- 2115 J10
- 2116 J8
- 2117 K10
- 2118 K10
- 2119F-13
- 2120F-14
- 2121 G16
- 2122 B8
- 2124 B12
- 2125F-14
- 2126G-17
- 2127 H12
- 2128G-13
- 2129G-13
- 2130G-15
- 2131 H15
- 2132 J4
- 2133 J6
- 2134 J4
- 2135 J14
- 2136 J15
- 2137 B7
- 2138E-12
- 2139 J10
- 3101 B3
- 3102 B7
- 3103F-9
- 3104G-10
- 3105G-11
- 3106F-15
- 3107F-15
- 3108 H9
- 3109 H9
- 3110 J-4
- 3111 J-3
- 3112-1 J2
- 3112-2 J-2
- 3113-1 D2
- 3113-2 D12
- 3113-3 C2
- 3113-4 C2
- 3116 J-9
- 3117-A J8
- 3117-B K8
- 3117-D K8
- 3118 J9
- 3119 H12
- 3120 H12
- 3121F-13
- 3122F-15
- 3123 B13
- 3127 H10
- 3128G-11
- 3129G-10
- 3333 J-9
- 3901 B3
- 3902 B7
- 3903 B12
- 3904 B14
- 3905 C16
- 3908 D13
- 3909 C9
- 3910 C9
- 3915F-16
- 3916F-16



ELECTRICAL DIAGRAM

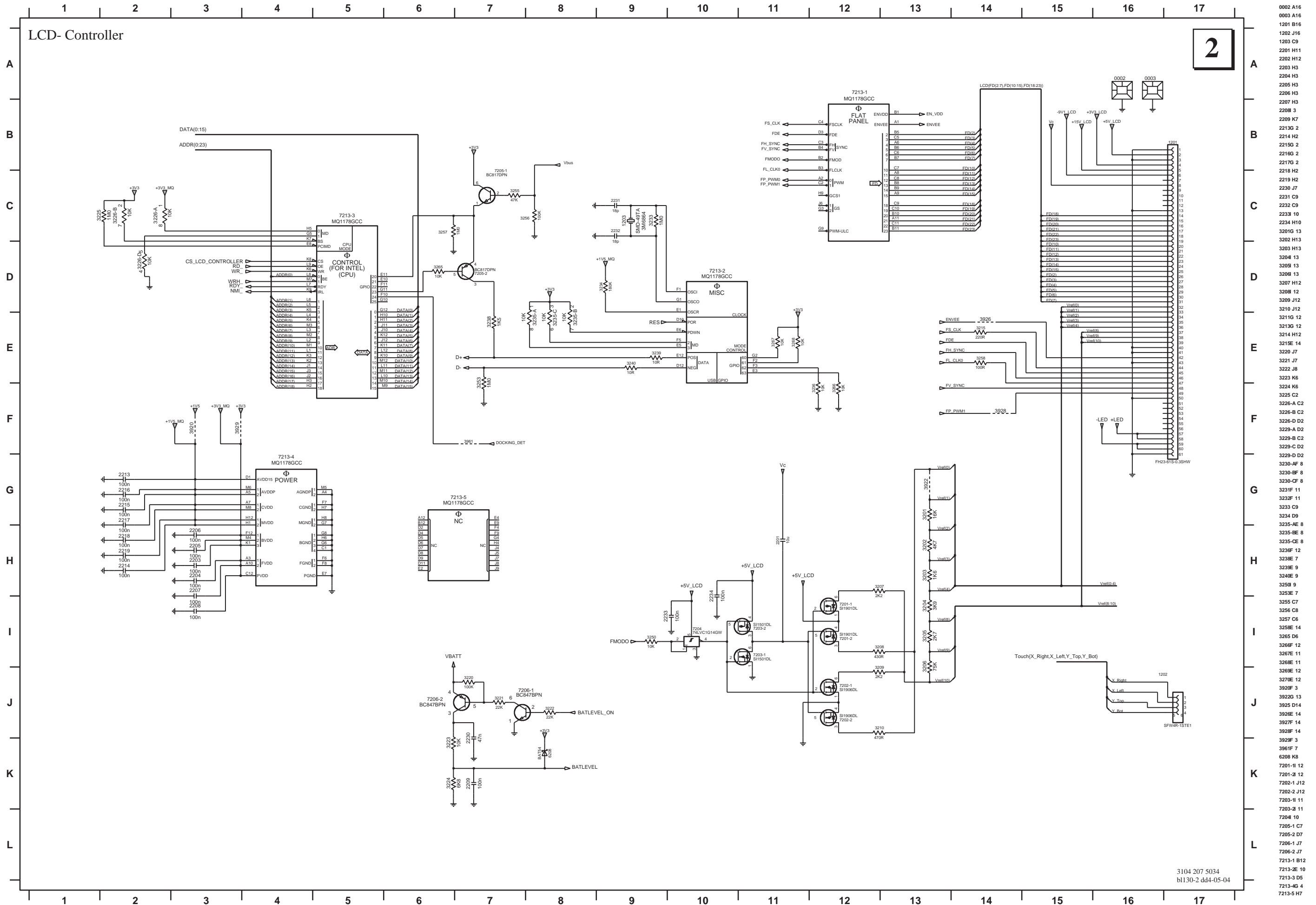

# ELECTRICAL DIAGRAM

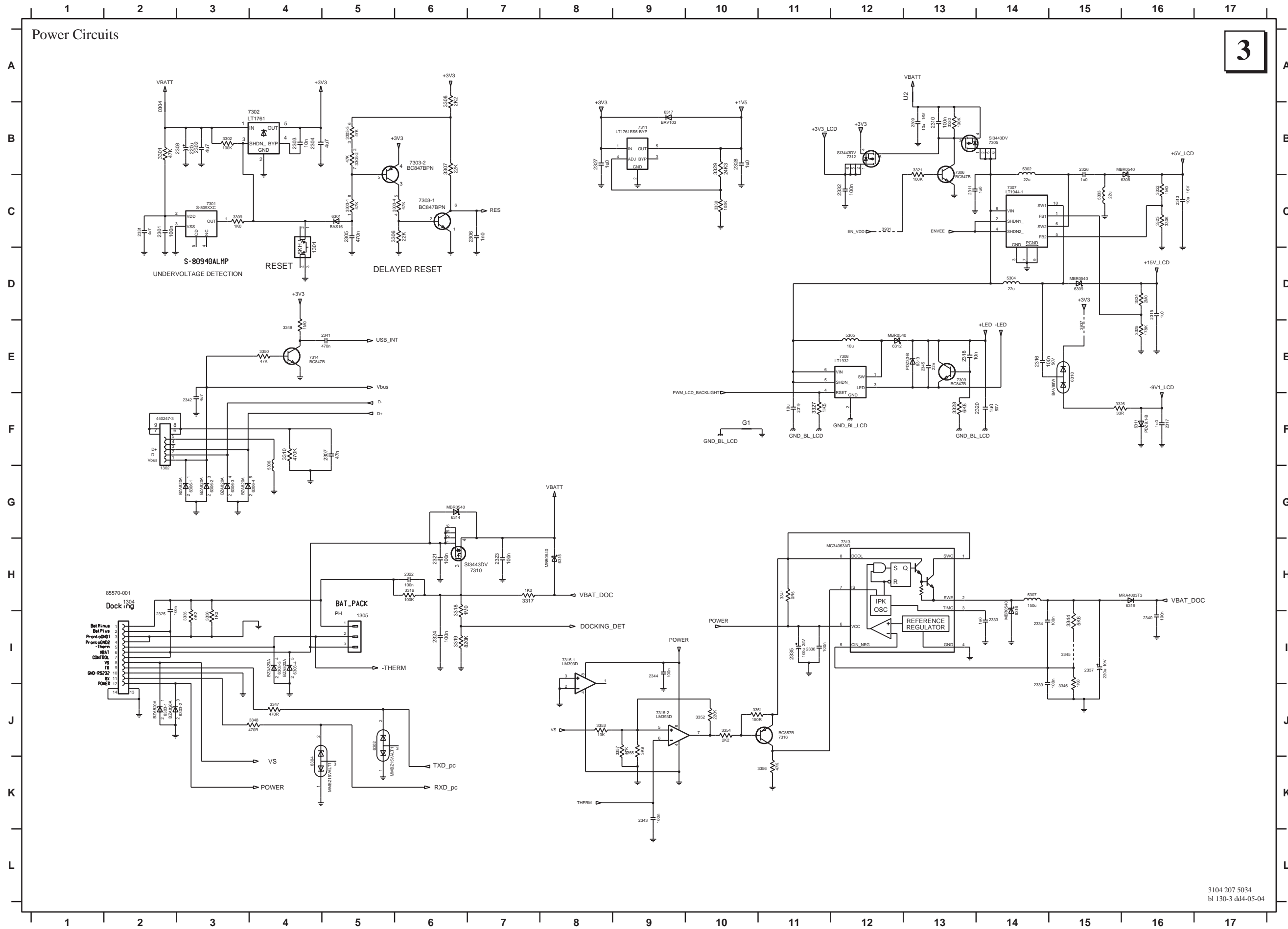

G1F 10	5302 B14
U2 A13	5303 C15
0304 B2	5304 D14
1301 C4	5305E 12
1302F 2	5306F 4
1304 2	5307 H14
1305 5	6301 C5
2301 C2	6302 J5
2302 B3	6303-1 J2
2303 B4	6303-2 J2
2304 B4	6303-3I 4
2305 C5	6303-4I 4
2306 C7	6304 K4
2307 F 5	6306-1G 3
2308 B3	6306-2G 3
2309 B13	6306-3G 3
2310 B13	6306-4G 3
2311 C13	6308 B16
2312 C16	6309 D15
2313 C16	6310E 15
2314 D15	6311F 16
2315 D16	6312E 12
2316E 14	6313E 13
2317F 16	6314G 6
2318E 13	6315 H8
2319F 11	6316 H14
2320F 14	6317 B9
2321 H6	6319 H16
2322 H6	7301 C3
2323 H7	7302 B4
2324 6	7303-1 C6
2325 H2	7303-2 B5
2326 B15	7305 B13
2327 B8	7306 B13
2328 B10	7307 C14
2329 C9	7308E 12
2330 B10	7309E 13
2331 C2	7310 H6
2332 C12	7311 B9
2333 14	7312 B12
2334 14	7313 H12
2335 11	7314E 4
2336 11	7315-II 8
2337 15	7315-2 J9
2338 16	7316 J11
2339 14	
2340 16	
2341E 5	
2342F 3	
2343 K9	
2344 9	
2345E 13	
3301 B2	
3302 B3	
3303-1 C5	
3303-2 B5	
3303-3 B5	
3303-4 C6	
3306 C6	
3307 B6	
3308 A6	
3309 C3	
3310F 4	
3316 H6	
3317 H7	
3318 H6	
3319 6	
3320 B13	
3321 B13	
3322 C16	
3323 C16	
3324 D16	
3325E 16	
3326F 15	
3327F 11	
3328F 13	
3329 B10	
3330 C10	
3334 C3	
3335 3	
3336 3	
3337 3	
3341 H11	
3344 15	
3345 15	
3346 15	
3347 J4	
3348 J4	
3349E 4	
3350E 4	
3351 J10	
3352 J10	
3353 J8	
3354 J10	
3355 J9	
3356 K11	
3357 J9	
3360 B4	
3361 C12	
3365 C9	
3366E 15	
3367E 15	
5301F 4	

ELECTRICAL DIAGRAM

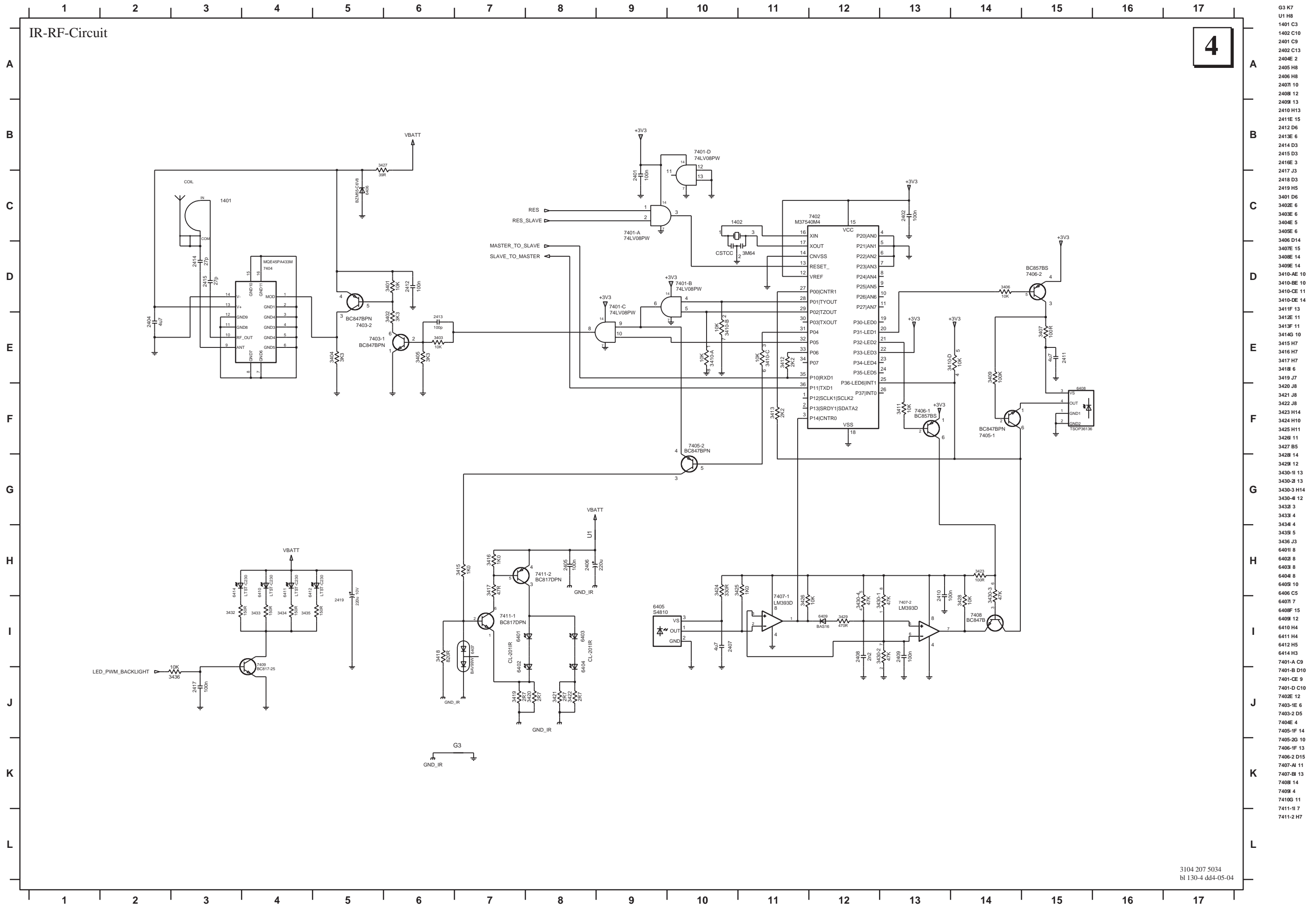

- G3 K7
- U1 H8
- 1401 C3
- 1402 C10
- 2401 C9
- 2402 C13
- 2404E 2
- 2405 H8
- 2406 H8
- 2407I 10
- 2408 I 12
- 2409I 13
- 2410 H13
- 2411E 15
- 2412 D6
- 2413E 6
- 2414 D3
- 2415 D3
- 2416E 3
- 2417 J3
- 2418 D3
- 2419 H5
- 3401 D6
- 3402E 6
- 3403E 6
- 3404E 5
- 3405E 6
- 3406 D14
- 3407E 15
- 3408E 14
- 3409E 14
- 3410-AE 10
- 3410-BE 10
- 3410-CE 11
- 3410-DE 14
- 3411F 13
- 3412E 11
- 3413F 11
- 3414G 10
- 3415 H7
- 3416 H7
- 3417 H7
- 3418 6
- 3419 J7
- 3420 J8
- 3421 J8
- 3422 J8
- 3423 H14
- 3424 H10
- 3425 H11
- 3426 I 11
- 3427 B5
- 3428 I 14
- 3429 I 12
- 3430-I 13
- 3430-2 I 13
- 3430-3 H14
- 3430-4 I 12
- 3432 I 3
- 3433 I 4
- 3434 I 4
- 3435 I 5
- 3436 J3
- 6401 I 8
- 6402 I 8
- 6403 I 8
- 6404 I 8
- 6405 I 10
- 6406 C5
- 6407 I 7
- 6408F 15
- 6409 I 12
- 6410 H4
- 6411 H4
- 6412 H5
- 6413 H3
- 7401-A C9
- 7401-B D10
- 7401-CE 9
- 7401-D C10
- 7402E 12
- 7403-1E 6
- 7403-2 D5
- 7404E 4
- 7405-1F 14
- 7405-2G 10
- 7406-1F 13
- 7406-2 D15
- 7407-A I 11
- 7407-B I 13
- 7408 I 14
- 7409 I 4
- 7410G 11
- 7411-I 7
- 7411-2 H7







# EXPLODED VIEW

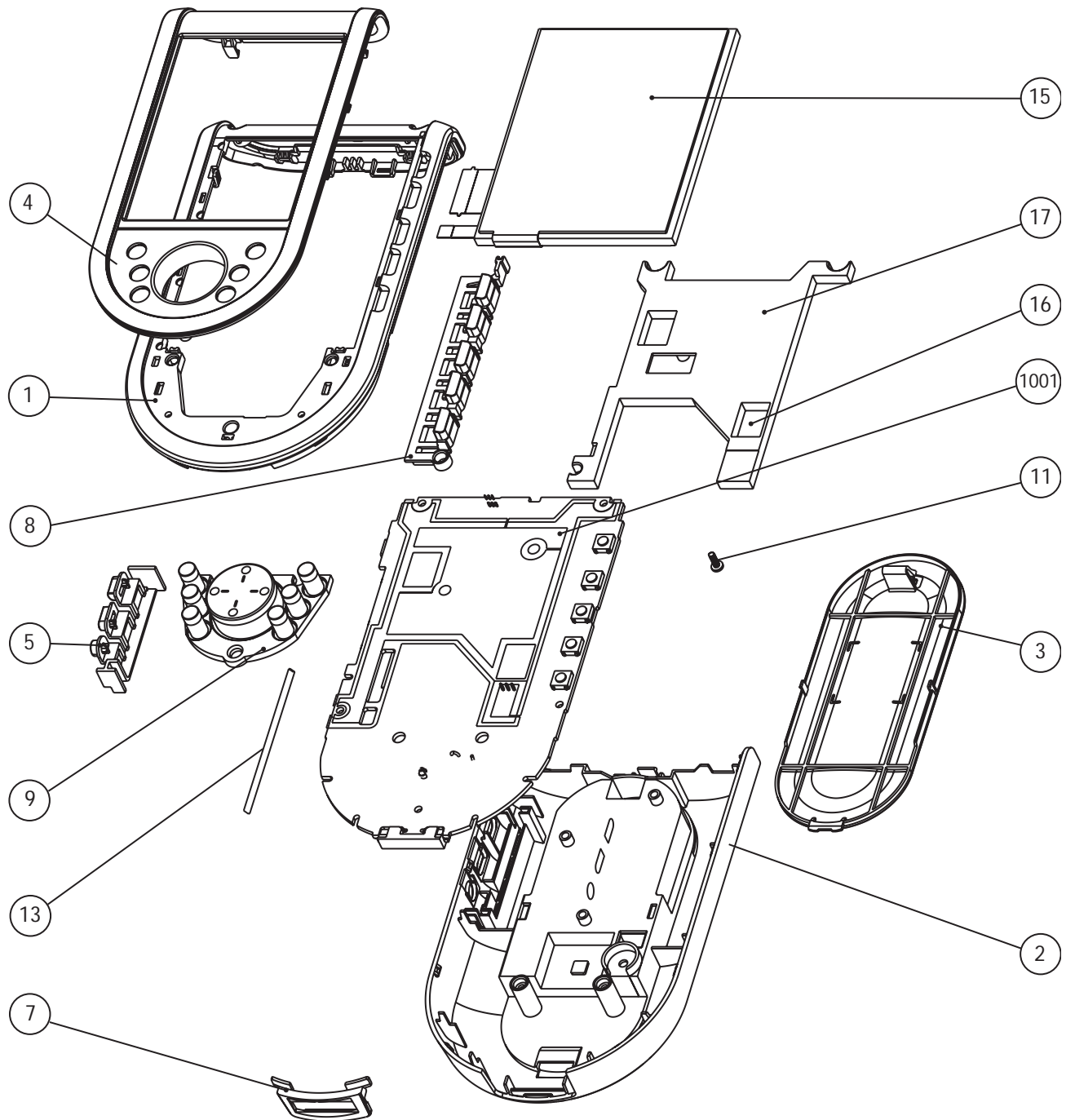

**MECHANICAL & ELECTRICAL PARTS LIST - TS9500****MECHANICAL PARTS**

1	3104 207 80810	TOPPART ASSY
2	3104 207 80820	BOTTOMPART ASSY
3	3104 207 80830	BATTERY LID
4	3104 207 80860	IR- WINDOW + BEZEL ASSY
5	3104 207 80870	SIDE BUTTONS ASST
7	3104 204 20970	DOC PLUG INSERT
8	3104 207 80890	ACTION KEYS ASSY
9	3104 207 80900	LOWER KEYMAT ASSY
11	3104 200 40040	TAPT TORX SCREW 2X6
13	3104 204 18750	GASKET LCD
15	9360 302 01110	LCD PANEL LPH7123-1
16	3104 204 20670	SOFT SHIELD 5000 GASKET
17	3104 204 20940	LCD SUPPORT PLATE
19	3104 204 20670	SOFT SHIELD 5000 GASKET

**MISCELLANEOUS**

3104 205 33420 IFU

**ELECTRICAL PARTS**

	3104 200 51270	BATTERYPACK
1001	3104 207 15010	MAIN BOARD ASSY /N1M+ T1M+ A1M (3104 207 40380)
1001	3104 207 15020	MAIN BOARD ASSY /U1S (3104 207 40270)



3104 200 51200	ADAPTOR /N1M - EUROPE
3104 200 51210	ADAPTOR /TIM - UK
3104 200 52290	ADAPTOR/ A1M - AUS
3104 200 51190	ADAPTOR/ U1S - US



3140 117 69600 USB CABLE SET

Note: Only the parts mentioned in this list are normal service parts

For more information:

E-mail: erik.gybels@philips.com

**ELECTRICAL PARTS LIST - TS9500**

MISCELLANEOUS			CAPACITORS		
1101	2422 543 01389	RES SM 20MHZ 16P HC-49S	2136	2238 916 19849	CER2 0603 Y5V 25V 100N P8020
1102	2422 543 00937	RES SM 32K76 12P5 DMX26S	2137	2238 916 19849	CER2 0603 Y5V 25V 100N P8020
1103	2422 527 01014	BUZZER 12X12 PKLCS1212	2138	2238 916 19849	CER2 0603 Y5V 25V 100N P8020
1104	2422 129 17113	SWI TILT 50DEG SPSF100	2139	2238 586 15609	CER2 0603 X7R 50V 100P PM10
1131	2422 128 03024	SWI TACT 50MA12V EVQPS	2201	2020 552 96815	CER2 1206 X5R 16V 10U PM10
1132	2422 128 03024	SWI TACT 50MA12V EVQPS	2203	2238 916 19849	CER2 0603 Y5V 25V 100N P8020
1133	2422 128 03024	SWI TACT 50MA12V EVQPS	2204	2238 916 19849	CER2 0603 Y5V 25V 100N P8020
1134	2422 128 02435	SWI TACT 50MA 12V SKHUAD	2205	2238 916 19849	CER2 0603 Y5V 25V 100N P8020
1135	2422 128 02435	SWI TACT 50MA 12V SKHUAD	2206	2238 916 19849	CER2 0603 Y5V 25V 100N P8020
1136	2422 128 02435	SWI TACT 50MA 12V SKHUAD	2207	2238 916 19849	CER2 0603 Y5V 25V 100N P8020
1137	2422 128 02435	SWI TACT 50MA 12V SKHUAD	2208	2238 916 19849	CER2 0603 Y5V 25V 100N P8020
1138	2422 128 02435	SWI TACT 50MA 12V SKHUAD	2209	2238 916 19849	CER2 0603 Y5V 25V 100N P8020
1201	2422 025 18203	CON H 61P F 0.30 SM FPC 0.2	2213	2238 916 19849	CER2 0603 Y5V 25V 100N P8020
1202	2422 025 17608	CON H 4P F 1.00 SM FPC 0.3	2214	2238 916 19849	CER2 0603 Y5V 25V 100N P8020
1203	2422 543 01396	RES XTL 3M6864 30P SMD-49	2215	2238 916 19849	CER2 0603 Y5V 25V 100N P8020
1301	2422 128 02435	SWI TACT 50MA 12V SKHUAD	2216	2238 916 19849	CER2 0603 Y5V 25V 100N P8020
1302	2422 025 18265	SOC USB H 5P F 0.8 440247	2217	2238 916 19849	CER2 0603 Y5V 25V 100N P8020
1304	2422 033 00534	CON H 12P F 1.00 85570	2218	2238 916 19849	CER2 0603 Y5V 25V 100N P8020
1305	2422 025 11072	CON V 3P M 2.00	2219	2238 916 19849	CER2 0603 Y5V 25V 100N P8020
1401	3104 207 80251	RF TRANSMITTER ANTENNA	2230	2238 786 15645	CER2 0603 X7R 16V 47N PM10
1402	2422 540 98541	RES CER 3M64 CSTCC6.00MG	2231	2238 867 15189	CER1 0603 NP0 50V 18P PM5
			2232	2238 867 15189	CER1 0603 NP0 50V 18P PM5
			2233	2238 916 19849	CER2 0603 Y5V 25V 100N P8020
			2234	2238 916 19849	CER2 0603 Y5V 25V 100N P8020
			2301	2238 916 19849	CER2 0603 Y5V 25V 100N P8020
			2302	2020 552 96305	CER2 0805 Y5V 10V 4U7 P8020
			2303	2238 586 15636	CER2 0603 X7R 50V 10N PM10
			2304	2020 552 96305	CER2 0805 Y5V 10V 4U7 P8020
			2305	2238 246 19858	CER2 0603 Y5V 10V 470N P8020
			2306	2238 586 15623	CER2 0603 X7R 50V 1N PM10
			2307	2238 786 15645	CER2 0603 X7R 16V 47N PM10
			2308	2020 024 90677	ELCAP SM WX 10V 220U PM20
			2309	2020 552 96815	CER2 1206 X5R 16V 10U PM10
			2310	2238 916 19849	CER2 0603 Y5V 25V 100N P8020
			2311	2020 552 96448	CER2 0805 X7R 16V 1U PM10
			2313	2020 552 96815	CER2 1206 X5R 16V 10U PM10
			2315	2020 552 96448	CER2 0805 X7R 16V 1U PM10
			2316	2222 580 15649	CER2 0805 X7R 50V 100N PM10
			2317	2020 552 96448	CER2 0805 X7R 16V 1U PM10
			2318	2238 586 15636	CER2 0603 X7R 50V 10N PM10
			2319	2020 552 96815	CER2 1206 X5R 16V 10U PM10
			2320	2020 552 96394	CER2 1210 X7R 50V 1U0 PM10
			2321	2238 916 19849	CER2 0603 Y5V 25V 100N P8020
			2322	2238 916 19849	CER2 0603 Y5V 25V 100N P8020
			2323	2238 916 19849	CER2 0603 Y5V 25V 100N P8020
			2324	2238 916 19849	CER2 0603 Y5V 25V 100N P8020
			2325	2238 916 19849	CER2 0603 Y5V 25V 100N P8020
			2326	2020 552 96448	CER2 0805 X7R 16V 1U PM10
			2327	2020 552 96448	CER2 0805 X7R 16V 1U PM10
			2328	2020 552 96448	CER2 0805 X7R 16V 1U PM10
			2331	2020 552 96305	CER2 0805 Y5V 10V 4U7 P8020
			2332	2238 916 19849	CER2 0603 Y5V 25V 100N P8020
			2333	2238 586 15623	CER2 0603 X7R 50V 1N PM10
			2334	2238 916 19849	CER2 0603 Y5V 25V 100N P8020
			2335	2020 024 90669	ELCAP SM WX 25V 100U PM20
2101	2238 867 15229	CER1 0603 NP0 50V 22P PM5			
2102	2238 867 15229	CER1 0603 NP0 50V 22P PM5			
2103	2238 916 19849	CER2 0603 Y5V 25V 100N P8020			
2104	2238 916 19849	CER2 0603 Y5V 25V 100N P8020			
2105	2238 916 19849	CER2 0603 Y5V 25V 100N P8020			
2106	2238 916 19849	CER2 0603 Y5V 25V 100N P8020			
2107	2238 916 19849	CER2 0603 Y5V 25V 100N P8020			
2108	2238 916 19849	CER2 0603 Y5V 25V 100N P8020			
2109	2238 867 15189	CER1 0603 NP0 50V 18P PM5			
2110	2238 867 15229	CER1 0603 NP0 50V 22P PM5			
2111	2238 586 15623	CER2 0603 X7R 50V 1N PM10			
2112	2238 586 15623	CER2 0603 X7R 50V 1N PM10			
2113	2238 586 15623	CER2 0603 X7R 50V 1N PM10			
2115	2238 586 15623	CER2 0603 X7R 50V 1N PM10			
2116	2238 586 15623	CER2 0603 X7R 50V 1N PM10			
2117	2238 586 15623	CER2 0603 X7R 50V 1N PM10			
2118	2238 916 19849	CER2 0603 Y5V 25V 100N P8020			
2119	2238 916 19849	CER2 0603 Y5V 25V 100N P8020			
2120	2238 916 19849	CER2 0603 Y5V 25V 100N P8020			
2121	2238 916 19849	CER2 0603 Y5V 25V 100N P8020			
2122	2238 916 19849	CER2 0603 Y5V 25V 100N P8020			
2123	2020 552 96305	CER2 0805 Y5V 10V 4U7 P8020			
2124	2020 552 96305	CER2 0805 Y5V 10V 4U7 P8020			
2125	2020 552 96305	CER2 0805 Y5V 10V 4U7 P8020			
2126	2020 552 96305	CER2 0805 Y5V 10V 4U7 P8020			
2127	2238 246 19858	CER2 0603 Y5V 10V 470N P8020			
2128	2238 916 19849	CER2 0603 Y5V 25V 100N P8020			
2129	2238 916 19849	CER2 0603 Y5V 25V 100N P8020			
2130	2238 916 19849	CER2 0603 Y5V 25V 100N P8020			
2131	2238 916 19849	CER2 0603 Y5V 25V 100N P8020			
2132	2238 916 19849	CER2 0603 Y5V 25V 100N P8020			
2133	2238 916 19849	CER2 0603 Y5V 25V 100N P8020			
2134	2238 916 19849	CER2 0603 Y5V 25V 100N P8020			
2135	2238 916 19849	CER2 0603 Y5V 25V 100N P8020			



**ELECTRICAL PARTS LIST - TS9500****CAPACITORS**

2339	2238 916 19849	CER2 0603 Y5V 25V 100N P8020
2340	2238 916 19849	CER2 0603 Y5V 25V 100N P8020
2341	2238 246 19858	CER2 0603 Y5V 10V 470N P8020
2342	2020 552 96305	CER2 0805 Y5V 10V 4U7 P8020
2343	2238 916 19849	CER2 0603 Y5V 25V 100N P8020
2344	2238 916 19849	CER2 0603 Y5V 25V 100N P8020
2345	2238 580 15641	CER2 0805 X7R 50V 22N PM10
2401	2238 916 19849	CER2 0603 Y5V 25V 100N P8020
2402	2238 916 19849	CER2 0603 Y5V 25V 100N P8020
2404	2020 552 96305	CER2 0805 Y5V 10V 4U7 P8020
2405	2238 916 19849	CER2 0603 Y5V 25V 100N P8020
2406	2020 024 90677	ELCAP SM WX 10V 220U PM20
2407	2020 552 96305	CER2 0805 Y5V 10V 4U7 P8020
2408	2238 586 15627	CER2 0603 X7R 50V 2N2 PM10
2409	2238 916 19849	CER2 0603 Y5V 25V 100N P8020
2410	2238 916 19849	CER2 0603 Y5V 25V 100N P8020
2411	2020 552 96305	CER2 0805 Y5V 10V 4U7 P8020
2412	2238 916 19849	CER2 0603 Y5V 25V 100N P8020
2413	2238 586 15609	CER2 0603 X7R 50V 100P PM10
2414	2238 867 15279	CER1 0603 NP0 50V 27P PM5
2415	2238 867 15279	CER1 0603 NP0 50V 27P PM5
2417	2238 916 19849	CER2 0603 Y5V 25V 100N P8020
2419	2020 024 90677	ELCAP SM WX 10V 220U PM20

**RESISTORS**

3101	2322 702 60105	RST SM 0603C21 1M PM5
3102	2322 702 60109	RST SM 0603C21 10R PM5
3103	2322 702 60106	RST SM 0603C21 10M PM5
3104	2322 702 60473	RST SM 0603C21 47K PM5
3105	2322 702 60222	RST SM 0603C21 2K2 PM5
3106	2322 702 60103	RST SM 0603C21 10K PM5
3108	2322 702 60102	RST SM 0603C21 1K PM5
3109	2322 702 60223	RST SM 0603C21 22K PM5
3110	2322 702 60222	RST SM 0603C21 2K2 PM5
3111	2322 702 60222	RST SM 0603C21 2K2 PM5
3112	2350 034 10473	RST NETW SM ARC24 4X 47K
3113	2350 034 10339	RST NETW SM ARC24 4X 33R
3116	2322 702 60333	RST SM 0603C21 33K PM5
3117	2350 034 10472	RST NETW SM ARC24 4X 4K7
3118	2322 702 60102	RST SM 0603C21 1K PM5
3119	2322 702 60334	RST SM 0603C21 330K PM5
3120	2322 702 60105	RST SM 0603C21 1M PM5
3121	2322 702 60103	RST SM 0603C21 10K PM5
3122	2322 702 60103	RST SM 0603C21 10K PM5
3123	2322 702 60103	RST SM 0603C21 10K PM5
3127	2322 702 60103	RST SM 0603C21 10K PM5
3128	2322 702 60105	RST SM 0603C21 1M PM5
3129	2322 702 60334	RST SM 0603C21 330K PM5
3201	2322 704 61603	RST SM 0603C22H 16K PM1
3202	2322 704 64702	RST SM 0603C22H 4K7 PM1
3203	2322 704 61602	RST SM 0603C22H 1K6 PM1
3204	2322 704 63902	RST SM 0603C22H 3K9 PM1
3205	2322 704 62702	RST SM 0603C22H 2K7 PM1
3206	2322 704 67503	RST SM 0603C22H 75K PM1
3207	2322 704 62202	RST SM 0603C22H 2K2 PM1
3208	2322 704 64301	RST SM 0603C22H 430R PM1
3209	2322 704 62202	RST SM 0603C22H 2K2 PM1

**RESISTORS**

3210	2322 704 64701	RST SM 0603C22H 470R PM1
3215	2322 702 60221	RST SM 0603C21 220R PM5
3220	2322 702 60104	RST SM 0603C21 100K PM5
3221	2322 702 60223	RST SM 0603C21 22K PM5
3222	2322 702 60223	RST SM 0603C21 22K PM5
3223	2322 704 61003	RST SM 0603C22H 10K PM1
3224	2322 704 66802	RST SM 0603C22H 6K8 PM1
3225	2322 702 60105	RST SM 0603C21 1M PM5
3226	2350 034 10103	RST NETW SM ARC24 4X 10K
3233	2322 702 60105	RST SM 0603C21 1M PM5
3234	2322 704 61804	RST SM 0603C22H 180K PM1
3235	2350 034 10103	RST NETW SM ARC24 4X 10K
3236	2322 702 60103	RST SM 0603C21 10K PM5
3238	2322 702 60152	RST SM 0603C21 1K5 PM5
3239	2322 702 60109	RST SM 0603C21 10R PM5
3240	2322 702 60109	RST SM 0603C21 10R PM5
3250	2322 702 60103	RST SM 0603C21 10K PM5
3253	2322 702 60105	RST SM 0603C21 1M PM5
3255	2322 702 60473	RST SM 0603C21 47K PM5
3256	2322 702 60104	RST SM 0603C21 100K PM5
3257	2322 702 60105	RST SM 0603C21 1M PM5
3258	2322 702 60101	RST SM 0603C21 100R PM5
3265	2322 702 60103	RST SM 0603C21 10K PM5
3266	2322 702 60103	RST SM 0603C21 10K PM5
3267	2322 702 60103	RST SM 0603C21 10K PM5
3268	2322 702 60103	RST SM 0603C21 10K PM5
3301	2322 702 60472	RST SM 0603C21 4K7 PM5
3302	2322 702 60104	RST SM 0603C21 100K PM5
3303	2350 034 10473	RST NETW SM ARC24 4X 47K
3306	2322 702 60223	RST SM 0603C21 22K PM5
3307	2322 702 60223	RST SM 0603C21 22K PM5
3308	2322 702 60222	RST SM 0603C21 2K2 PM5
3309	2322 702 60102	RST SM 0603C21 1K PM5
3310	2322 702 60474	RST SM 0603C21 470K PM5
3316	2322 702 60104	RST SM 0603C21 100K PM5
3317	2322 702 60102	RST SM 0603C21 1K PM5
3318	2322 702 60105	RST SM 0603C21 1M PM5
3319	2322 702 60824	RST SM 0603C21 820K PM5
3320	2322 702 60104	RST SM 0603C21 100K PM5
3321	2322 702 60104	RST SM 0603C21 100K PM5
3322	2322 704 61005	RST SM 0603C22H 1M PM1
3323	2322 704 63304	RST SM 0603C22H 330K PM1
3324	2322 704 62005	RST SM 0603C22H 2M PM1
3325	2322 704 61784	RST SM 0603C22H 178K PM1
3326	2322 702 60339	RST SM 0603C21 33R PM5
3327	2322 702 60152	RST SM 0603C21 1K5 PM5
3328	2322 702 60682	RST SM 0603C21 6K8 PM5
3329	2322 704 62433	RST SM 0603C22H 24K3 PM1
3330	2322 704 61054	RST SM 0603C22H 105K PM1
3333	2322 702 60333	RST SM 0603C21 33K PM5
3335	2350 511 15207	RST SM 0805 LRC11P 0R2
3336	2322 702 60108	RST SM 0603C21 1R PM5
3341	2350 511 15507	RST SM 0805 LRC11P 0R5
3344	2322 702 60562	RST SM 0603C21 5K6 PM5
3345	2322 702 96001	RST SM 0603 JUMP.
3346	2322 702 60102	RST SM 0603C21 1K PM5
3347	2322 702 60471	RST SM 0603C21 470R PM5

**ELECTRICAL PARTS LIST - TS9500****RESISTORS**

3348	2322 702 60471	RST SM 0603C21	470R PM5
3349	2322 702 60105	RST SM 0603C21	1M PM5
3350	2322 702 60473	RST SM 0603C21	47K PM5
3351	2322 702 60151	RST SM 0603C21	150R PM5
3352	2322 702 60224	RST SM 0603C21	220K PM5
3353	2322 702 60103	RST SM 0603C21	10K PM5
3354	2322 702 60222	RST SM 0603C21	2K2 PM5
3355	2322 702 60392	RST SM 0603C21	3K9 PM5
3356	2322 702 60473	RST SM 0603C21	47K PM5
3357	2322 702 60473	RST SM 0603C21	47K PM5
3401	2322 702 60103	RST SM 0603C21	10K PM5
3402	2322 702 60332	RST SM 0603C21	3K3 PM5
3403	2322 702 60103	RST SM 0603C21	10K PM5
3404	2322 702 60332	RST SM 0603C21	3K3 PM5
3405	2322 702 60332	RST SM 0603C21	3K3 PM5
3406	2322 702 60103	RST SM 0603C21	10K PM5
3407	2322 702 60101	RST SM 0603C21	100R PM5
3409	2322 702 60104	RST SM 0603C21	100K PM5
3410	2350 034 10103	RST NETW ARC24 4X 10K	
3411	2322 702 60103	RST SM 0603C21	10K PM5
3412	2322 702 60222	RST SM 0603C21	2K2 PM5
3413	2322 702 60222	RST SM 0603C21	2K2 PM5
3415	2322 702 60102	RST SM 0603C21	1K PM5
3416	2322 702 60102	RST SM 0603C21	1K PM5
3417	2322 702 60479	RST SM 0603C21	47R PM5
3418	2322 702 60821	RST SM 0603C21	820R PM5
3419	2322 702 60278	RST SM 0603C21	2R7 PM5
3420	2322 702 60278	RST SM 0603C21	2R7 PM5
3421	2322 702 60278	RST SM 0603C21	2R7 PM5
3422	2322 702 60278	RST SM 0603C21	2R7 PM5
3423	2322 702 60101	RST SM 0603C21	100R PM5
3424	2322 702 60331	RST SM 0603C21	330R PM5
3425	2322 702 60102	RST SM 0603C21	1K PM5
3426	2322 702 60103	RST SM 0603C21	10K PM5
3427	2322 702 60399	RST SM 0603C21	39R PM5
3428	2322 702 60103	RST SM 0603C21	10K PM5
3429	2322 702 60471	RST SM 0603C21	470R PM5
3430	2350 034 10473	RST NETW SM ARC24 4X 47K	
3432	2322 702 60151	RST SM 0603C21	150R PM5
3433	2322 702 60151	RST SM 0603C21	150R PM5
3434	2322 702 60151	RST SM 0603C21	150R PM5
3435	2322 702 60151	RST SM 0603C21	150R PM5
3436	2322 702 60103	RST SM 0603C21	10K PM5
3901	2322 702 96001	RST SM 0603 JUMP.	
3902	2322 702 96001	RST SM 0603 JUMP.	
3903	2322 702 96001	RST SM 0603 JUMP.	
3904	2322 702 96001	RST SM 0603 JUMP.	
3905	2322 702 96001	RST SM 0603 JUMP.	
3909	2322 702 96001	RST SM 0603 JUMP.	
3915	2322 702 96001	RST SM 0603 JUMP.	
3916	2322 702 96001	RST SM 0603 JUMP.	
3917	2322 702 96001	RST SM 0603 JUMP.	
3918	2322 702 96001	RST SM 0603 JUMP.	
3920	2322 702 96001	RST SM 0603 JUMP.	
3922	2322 702 96001	RST SM 0603 JUMP.	
3926	2322 702 96001	RST SM 0603 JUMP.	
3928	2322 702 96001	RST SM 0603 JUMP.	

**RESISTORS**

3929	2322 702 96001	RST SM 0603 JUMP.
3931	2322 702 96001	RST SM 0603 JUMP.
3937	2322 702 96001	RST SM 0603 JUMP.
3961	2322 702 96001	RST SM 0603 JUMP.

**FILTERS**

5302	2422 536 00164	IND FXD SM 22U PM10
5303	2422 536 00164	IND FXD SM 22U PM10
5304	2422 536 00164	IND FXD SM 22U PM10
5305	2422 536 00592	IND FXD SM 10U PM10
5306	2422 549 41222	IND FXD 100MHZ 120R
5307	2422 536 00666	IND FXD SM 150U PM10

**DIODES**

6101	9337 422 80215	DIO SIG SM BAT54
6102	9340 260 10115	DIO SIG SM BAV99W
6103	9337 422 80215	DIO SIG SM BAT54
6104	9340 260 10115	DIO SIG SM BAV99W
6208	9337 422 80215	DIO SIG SM BAT54
6301	9334 606 20215	DIO SIG SM BAS16
6302	9322 168 12685	DIO REG SM MMBZ15V
6303	9340 560 46115	DIO SUP SM BZA820A
6304	9322 168 12685	DIO REG SM MMBZ15V
6306	9340 560 46115	DIO SUP SM BZA820A
6308	9322 184 82685	DIO REC SM MBR0540
6309	9322 184 82685	DIO REC SM MBR0540
6310	9340 260 10115	DIO SIG SM BAV99W
6311	9340 548 58115	DIO REG SM PDZ9.1B
6312	9322 184 82685	DIO REC SM MBR0540
6313	9340 548 71115	DIO REG SM PDZ33B
6314	9322 184 82685	DIO REC SM MBR0540
6315	9322 184 82685	DIO REC SM MBR0540
6316	9322 184 82685	DIO REC SM MBR0540
6317	9336 993 60115	DIO SIG SM BAV103
6319	9322 197 25668	DIO REC SM MRA4003
6401	9322 172 08685	LED IR SM CL-201IR-X
6402	9322 172 08685	LED IR SM CL-201IR-X
6403	9322 172 08685	LED IR SM CL-201IR-X
6404	9322 172 08685	LED IR SM CL-201IR-X
6405	9322 105 11682	OPT SEN S4810
6406	9322 129 38685	DIO SM BZM55-C6V8
6407	9340 260 10115	DIO SIG SM BAV99W
6408	9322 197 80668	IR RECEIVER TSOP36136
6409	9334 606 20215	DIO SIG SM BAS16
6410	9322 200 18685	LED SM LTST-C230TBKT
6411	9322 200 18685	LED SM LTST-C230TBKT
6412	9322 200 18685	LED SM LTST-C230TBKT
6414	9322 200 18685	LED SM LTST-C230TBKT

**TRANSISTORS & IC's**

7101	9322 203 03671	IC SM M30800SAFP
7102	9351 960 10118	IC SM 74LVC139PW
7103	9322 195 36668	IC SM M68AW256ML
7105	9335 895 90215	TRA SIG SM BC847B
7106	9340 425 10115	TRA SIG SM BC857BS
7107	9340 425 20115	TRA SIG SM BC847BS
7110	9352 627 55125	IC SM 74AHC1G08GW
7111	9352 627 55125	IC SM 74AHC1G08GW
7112	9352 630 02125	IC SM 74AHC1G125GW

## ELECTRICAL PARTS LIST - TS9500

---

### TRANSISTORS & IC's

---

7113	9352 630 03125	IC SM 74AHC1G126GW
7114	9352 627 77165	IC SM 74AHC1G00GW
7115	9352 627 56125	IC SM 74AHC1G32GW
7116	9352 627 56125	IC SM 74AHC1G32GW
7117	9352 627 77165	IC SM 74AHC1G00GW
7118	9352 627 56125	IC SM 74AHC1G32GW
7122	9352 627 77165	IC SM 74AHC1G00GW
7201	9322 198 60685	FET SIG SM SI1901DL
7202	9322 198 64685	FET SIG SM SI1906DL
7203	9322 198 61685	FET SIG SM SI1501DL
7204	9352 685 95125	IC SM 74LVC1G14GW
7205	9340 573 20115	TRA SIG SM BC817DPN
7206	9340 425 30115	TRA SIG SM BC847BPN
7213	9322 197 90671	IC SM MQ1178GCC
7301	9322 185 27685	IC SM S-80940CLMC-G7A
7302	9322 171 42685	IC SM LT1761ES5-3.3
7303	9340 425 30115	TRA SIG SM BC847BPN
7305	9322 140 10685	FET POW SM SI3443DV
7306	9335 895 90215	TRA SIG SM BC847B
7307	9322 184 55668	IC SM LT1944-1EMS
7308	9322 179 37685	IC SM LT1932ES6
7309	9335 895 90215	TRA SIG SM BC847B
7310	9322 140 10685	FET POW SM SI3443DV
7311	9322 197 18685	IC SM LT1761ES5-BYP
7312	9322 140 10685	FET POW SM SI3443DV
7313	9322 033 40668	IC SM MC34063AD
7314	9335 895 90215	TRA SIG SM BC847B
7315	9339 575 30668	IC SM LM393D
7316	9335 897 60215	TRA SIG SM BC857B
7401	9351 742 80118	IC SM 74LV08PW
7403	9340 425 30115	TRA SIG SM BC847BPN
7405	9340 425 30115	TRA SIG SM BC847BPN
7406	9340 425 10115	TRA SIG SM BC857BS
7407	9339 575 30668	IC SM LM393D
7408	9335 895 90215	TRA SIG SM BC847B
7409	9336 286 30215	TRA SIG SM BC817-25
7411	9340 573 20115	TRA SIG SM BC817DPN
7104	3104 208 57342	RC9500/U1S SW ASSY
7121	9322 206 57671	IC SM K9F5616U0C-PCB0
7402	3104 208 83821	IC- SM M37540M4-090FP
7404	2722 171 08795	OSC 433MHZ

---



***DOCKING STATION***  
***DS9500***

# MECHANICAL INSTRUCTIONS

## Set Disassembly - Docking station



- 1. Remove the four rubber feet
- 2. Remove 4 x screw  
see picture - arrows

### Overview snapholes



- 3. Put a sharp knife between toppart and bottom part and use this as lever to separate the two parts.  
For the correct position of the knife see snapholes in picture

### Overview disassembled parts

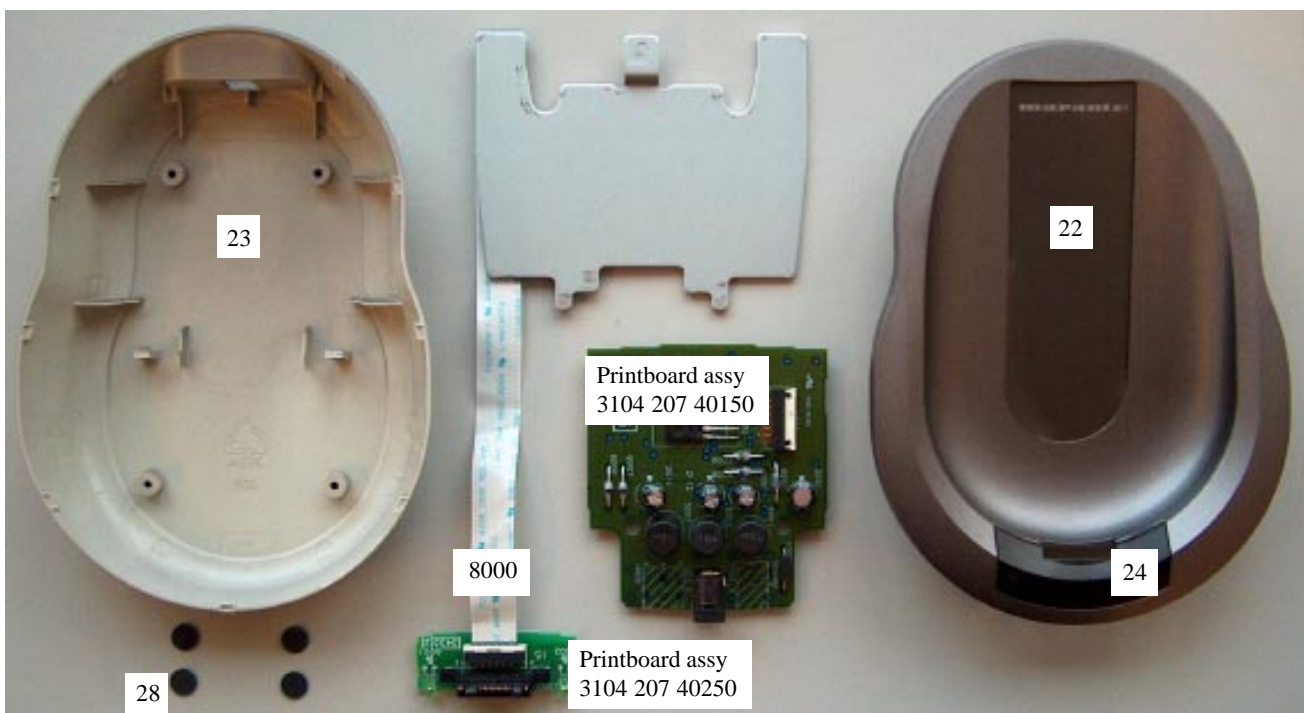





**CHARGE BOARD - Component Layout**

1001 A1	2008 B1	3010 C2	3020 C1	6002 B2
1002 B3	3001 B3	3011 C2	3021 B1	6003 B1
1003 B3	3002 B1	3012 C2	3022 B1	6004 B1
2001 B3	3003 B1	3013 C1	3023 C1	6005 B2
2002 B3	3004 B1	3014 B1	3024 B2	6007 B1
2003 B2	3005 B2	3015 B2	3025 B2	7001 C1
2004 C1	3006 C2	3016 C1	3026 C1	7002 B3
2005 C1	3007 C2	3017 C1	3027 B1	7003 B2
2006 B2	3008 C2	3018 C1	5001 B2	7004 B1
2007 B2	3009 B2	3019 B2	6001 B2	

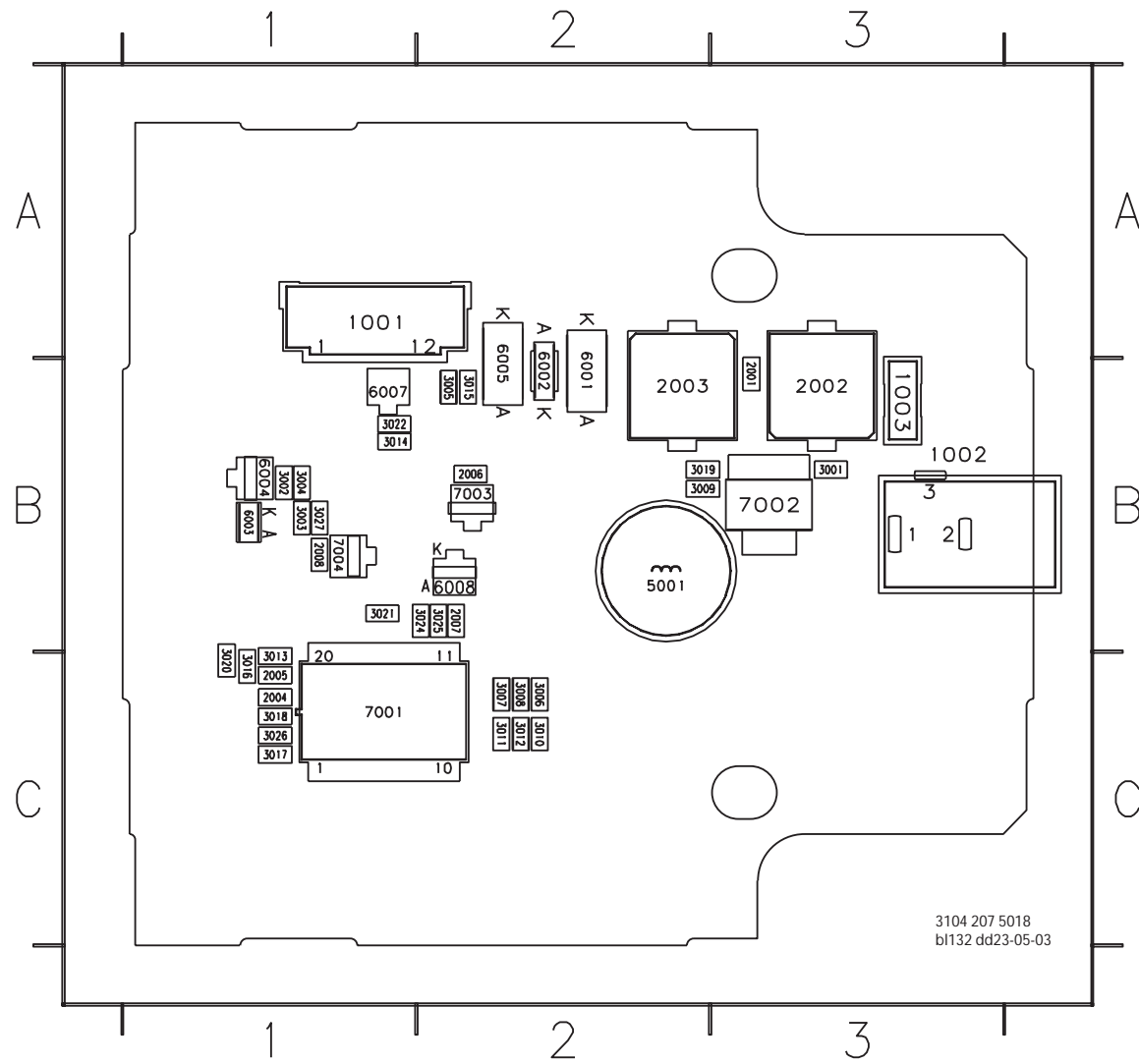

**LED BOARD DIAGRAM & Component Layout**

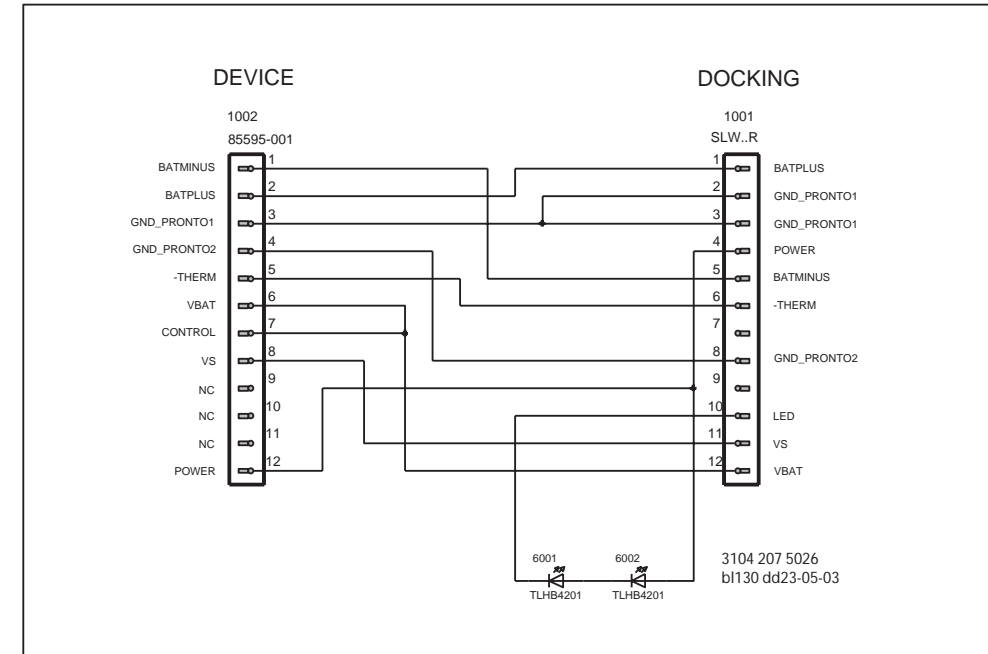

**Component Layout**

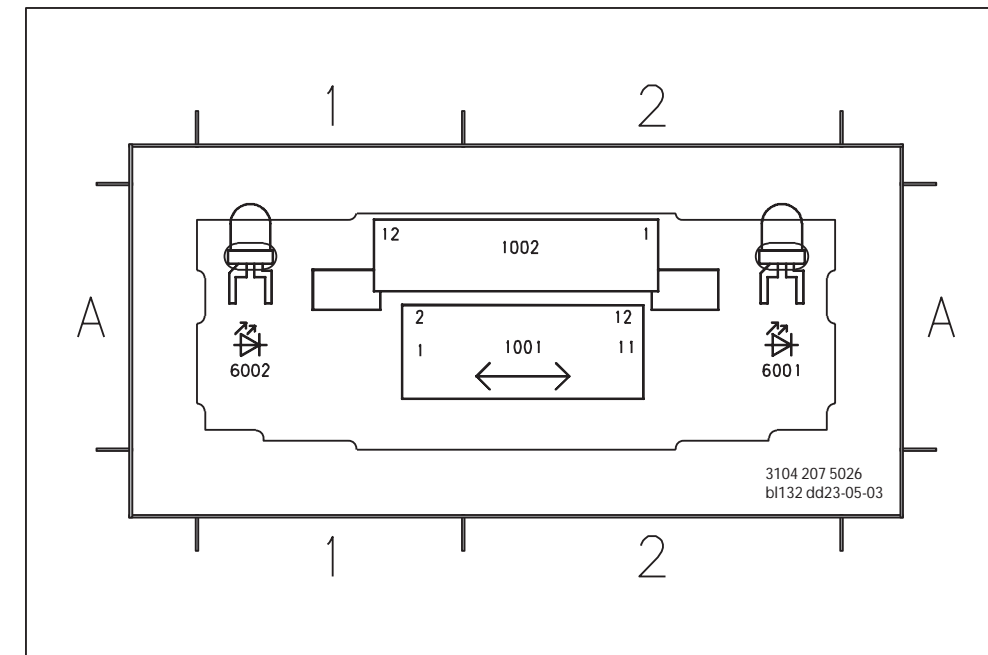

## MECHANICAL & ELECTRICAL PARTS LIST - Docking Station DS9500

---

### ELECTRICAL PARTS

---

1003 2422 086 11101	FUSE T750mA 125V UL
3104 207 15001	DOCKING STATION (3104 207 14600)
3104 207 14840	PRINTBOARD ASSY CONNECTOR (3104 207 40250)



DOCKING STATION



PRINTBOARD ASSY CONNECTOR

Note: Only the parts mentioned in this list are normal service parts

For more information:

E-mail: [erik.gybels@philips.com](mailto:erik.gybels@philips.com)

**ELECTRICAL & MECHANICAL PARTS LIST- Docking Station DS9500****MECHANICAL PARTS**

22	3104 207 80940	TOPPART ASSY
23	3104 207 80920	BOTTOMPART ASSY
24	3104 204 18540	IR- WINDOW
28	3139 224 20710	RUBBER FEET

**PRINTBOARD ASSY 3104 207 40150****MISCELLANEOUS**

1001	2422 025 17962	CON H 12P F 1.00 SM
1002	2422 026 03455	SOC SUPP H 1P M DC 2MM
1003	2422 086 11101	FUSE T 750MA 125V UL

**CAPACITORS**

2001	2238 586 15618	CER2 0603 50V 470P PM10
2002	2020 024 90669	ELCAP SM 25V 100U PM20
2003	2020 024 90677	ELCAP SM 10V 220U PM20
2004	2238 586 15618	CER2 0603 50V 470P PM10
2005	2238 586 15618	CER2 0603 50V 470P PM10

2006	2238 586 15623	CER2 0603 50V 1N PM10
2007	2238 916 19849	CER2 0603 25V 100N P8020
2008	2238 586 15636	CER2 0603 50V 10N PM10

**RESISTORS**

3001	2322 702 60102	RST SM 0603 RC21 1K
3002	2322 702 60824	RST SM 0603 RC21 820K
3003	2322 702 60101	RST SM 0603 RC21 100R
3004	2322 702 60334	RST SM 0603 RC21 330K
3005	2322 702 60629	RST SM 0603 RC21 62R

3006	2322 702 60103	RST SM 0603 RC21 10K
3007	2322 704 62053	RST SM 0603 RC22H 20K5
3008	2322 704 61583	RST SM 0603 RC22H 15K8
3009	2322 702 60122	RST SM 0603 RC21 1K2
3010	2322 702 60683	RST SM 0603 RC21 68K

3011	2322 704 61003	RST SM 0603 RC22H 10K
3012	2322 704 62673	RST SM 0603 RC22H 26K7
3013	2322 702 60473	RST SM 0603 RC21 47K
3014	2322 702 60182	RST SM 0603 RC21 1K8
3015	2322 702 60568	RST SM 0603 RC21 5R6

3016	2322 702 60563	RST SM 0603 RC21 56K
3017	2322 702 60333	RST SM 0603 RC21 33K
3018	2322 702 60333	RST SM 0603 RC21 33K
3019	2322 702 60471	RST SM 0603 RC21 470R
3020	2322 702 60103	RST SM 0603 RC21 10K

3021	2322 702 60103	RST SM 0603 RC21 10K
3022	2322 702 60471	RST SM 0603 RC21 470R
3024	2322 702 60221	RST SM 0603 RC21 220R
3025	2322 702 60221	RST SM 0603 RC21 220R
3026	2322 702 60471	RST SM 0603 RC21 470R

3027	2322 702 60103	RST SM 0603 RC21 10K
------	----------------	----------------------

**FILTERS**

5001	2422 536 00627	IND FXD 330U PM10 A
------	----------------	---------------------

**DIODES**

6001	9322 197 25668	DIO REC SM MRA4003
6002	9322 184 82685	DIO REC SM MBR0540
6003	9322 129 38685	DIO REG SM BZM55-C6V8
6004	9339 763 60215	DIO SIG SM BAT54A

6005	9322 197 25668	DIO REC SM MRA4003
6007	9322 168 12685	DIO REG SM MMBZ15VAL
6008	9337 422 80215	DIO SIG SM BAT54

**TRANSISTORS & IC's**

7001	9352 604 38118	IC SM TEA1103T_N2
7002	9339 172 80135	TRA POW SM BCP51-10
7003	9336 286 30215	TRA SIG SM BC817-25
7004	9335 895 90215	TRA SIG SM BC847B

**PRINTBOARD ASSY 3104 207 40250****MISCELLANEOUS**

1001	2422 025 17146	CON H 12P F 1.00
1002	8204 161 43591	CON BM FCI-85595-001
8000	3104 200 51370	FLEXCABLE

**DIODES**

6001	9322 192 91676	LED VS TLHB4201
6002	9322 192 91676	LED VS TLHB4201