

Service Manual

SA7001KI /N1B/N1S

SA7001KI

Super Audio CD Player

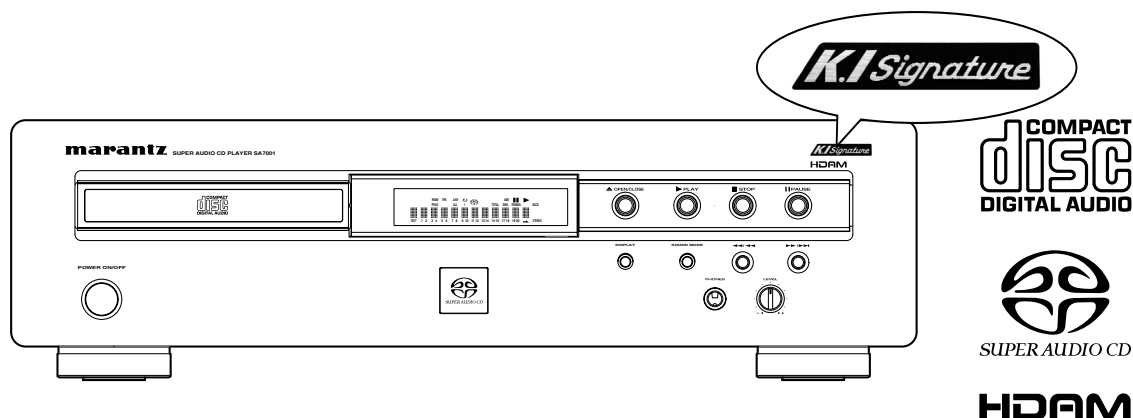

TABLE OF CONTENTS

SECTION 1	PAGE
1. TECHNICAL SPECIFICATIONS AND UPDATE DISC	1-1
2. SERVICE HINTS AND TOOLS	1-2
3. WARNING AND LASER SAFETY INSTRUCTIONS	1-3
4. TAKING THE DISC OUT OF EMERGENCY	1-4
5. UPDATA FIRMWARE	1-5
6. SERVICE MODE	1-6
7. BLOCK DIAGRAM	1-7
8. SCHEMATIC DIAGRAM	1-9
9. PARTS LOCATION	1-15
10. MICROPROCESSOR AND IC DATA	1-21
11. EXPLODED VIEW AND PARTS LIST	1-25
12. ELECTRICAL PARTS LIST	1-28
SECTION 2 (MECHA LOADER AND MECHA TRAVERSE)	
1. EXPLODED VIEW AND PARTS LIST	2-2
SECTION 3 (SUPER AUDIO CD PWB MODULE)	
1. IC DATA	3-2
2. BLOCK DIAGRAM	3-23
3. SCHEMATIC DIAGRAM	3-25
4. PARTS LOCATION	3-37
5. ELECTRICAL PARTS LIST	3-41

Please use this service manual with referring to the user guide (D.F.U.) without fail.
修理の際は、必ず取扱説明書を準備し操作方法を確認の上作業を行ってください。

marantz®

SA7001KI

MARANTZ DESIGN AND SERVICE

Using superior design and selected high grade components, **MARANTZ** company has created the ultimate in stereo sound. Only original **MARANTZ** parts can insure that your **MARANTZ** product will continue to perform to the specifications for which it is famous.

Parts for your **MARANTZ** equipment are generally available to our National Marantz Subsidiary or Agent.

ORDERING PARTS :

Parts can be ordered either by mail or by Fax.. In both cases, the correct part number has to be specified.

The following information must be supplied to eliminate delays in processing your order :

1. Complete address
2. Complete part numbers and quantities required
3. Description of parts
4. Model number for which part is required
5. Way of shipment
6. Signature : any order form or Fax. must be signed, otherwise such part order will be considered as null and void.

USA

MARANTZ AMERICA, INC
1100 MAPLEWOOD DRIVE
ITASCA, IL. 60143
USA
PHONE : 630 - 741 - 0300
FAX : 630 - 741 - 0301

EUROPE / TRADING

MARANTZ EUROPE B.V.
P. O. BOX 8744, BUILDING SILVERPOINT
BEEMDSTRAAT 11, 5653 MA EINDHOVEN
THE NETHERLANDS
PHONE : +31 - 40 - 2507844
FAX : +31 - 40 - 2507860

CANADA

MARANTZ CANADA INC.
5-505 APPLE CREEK BLVD.
MARKHAM, ONTARIO L3R 5B1
CANADA
PHONE : 905 - 415 - 9292
FAX : 905 - 475 - 4159

AUSTRALIA

QualiFi Pty Ltd,
24 LIONEL ROAD,
MT. WAVERLEY VIC 3149
AUSTRALIA
PHONE : +61 - (0)3 - 9543 - 1522
FAX : +61 - (0)3 - 9543 - 3677

THAILAND

MRZ STANDARD CO., LTD
746 - 754 MAHACHAI ROAD.,
WANGBURAPAPIROM, PHRANAKORN,
BANGKOK, 10200 THAILAND
PHONE : +66 - 2 - 222 9181
FAX : +66 - 2 - 224 6795

SINGAPORE

WO KEE HONG DISTRIBUTION PTE LTD
No.1 JALAN KILANG TIMOR
#08-03 PACIFIC TECH CENTRE
SINGAPORE 159303
PHONE : +65 6376 0338
FAX : +65 6376 0166

NEW ZEALAND

WILDASH AUDIO SYSTEMS NZ
14 MALVERN ROAD MT ALBERT
AUCKLAND NEW ZEALAND
PHONE : +64 - 9 - 8451958
FAX : +64 - 9 - 8463554

TAIWAN

PAI- YUING CO., LTD.
6 TH FL NO, 148 SUNG KIANG ROAD,
TAIPEI, 10429, TAIWAN R.O.C.
PHONE : +886 - 2 - 25221304
FAX : +886 - 2 - 25630415

MALAYSIA

WO KEE HONG ELECTRONICS SDN. BHD.
2ND FLOOR BANGUNAN INFINITE CENTRE
LOT 1, JALAN 13/6, 46200 PETALING JAYA
SELANGOR DARUL EHSAN, MALAYSIA
PHONE : +60 - 3 - 7954 8088
FAX : +60 - 3 - 7954 7088

JAPAN

D&M Holdings Inc.
D&M BUILDING, 2-1 NISSHIN-CHO,
KAWASAKI-KU, KAWASAKI-SHI,
KANAGAWA, 210-8569 JAPAN

株式会社 ディーアンドエムホールディングス

本 社 〒210-8569
神奈川県川崎市川崎区日新町2-1 D&Mビル

KOREA

MARANTZ KOREA CO., LTD.
ROOM 604, ELECTRO OFFICE, 16-58,
HANGGANG-RO 3GA, YONGSAN-KU,
SEOUL, 140-013, KOREA
PHONE : +82 - 2 - 323 - 2155
FAX : +82 - 2 - 323 - 2154

CHINA

MARANTZ SHANGHAI TRADING LTD.
ROOM.506 SHANGHAI LIGHT INDUSTRY MANSION
1578 NANJING (WEST) ROAD SHANGHAI
CHINA
TEL : 021 - 6248 - 1064
FAX : 021 - 6248 - 3565

SHOCK, FIRE HAZARD SERVICE TEST :

CAUTION : After servicing this appliance and prior to returning to customer, measure the resistance between either primary AC cord connector pins (with unit NOT connected to AC mains and its Power switch ON), and the face or Front Panel of product and controls and chassis bottom.

Any resistance measurement less than 1 Megohms should cause unit to be repaired or corrected before AC power is applied, and verified before it is return to the user/customer.

In case of difficulties, do not hesitate to contact the Technical
Department at above mentioned address.

1. TECHNICAL SPECIFICATIONS AND UPDATE DISC

	Super Audio CD	CD
Audio Characteristics		
Analog output		
Channels	2channels	2channels
Frequency range	2Hz — 100kHz	2Hz — 20kHz
Frequency characteristics	2Hz — 50kHz (-3dB)	2Hz — 20kHz
Dynamic range	112dB	More than 100dB
THD (1kHz)	0.002%	0.002%
Wow & Flutter	Precision of quartz	Precision of quartz
Output level	2.3V RMS stereo	2.3V RMS stereo
Digital output		
Output level (Cinch JACK)	—	0.5Vp-p (75Ω)
Output level (Optical)	—	-19dBm
Headphone output level	0.5W / 32Ω (max, Vol.)	0.5W / 32Ω (max, Vol.)
Optical Readout System		
Laser	AlGaAs	AlGaAs
Wave length	650nm	780nm
Signal format		
Sampling frequency	1-bit DSD 2.8224MHz	16-bit linear PCM 44.1kHz

Power Supply

Input Voltage, Frequency [N]..... AC 230V 50Hz
 Power Consumption..... 19W

Cabinet, etc.

Dimensions 440 × 128 × 339mm
 Net weight 7.7kg
 Operating temperatures +5°C ~ +35°C
 Operating humidity 5 ~ 90% (without dew)

Accessories

- Remote control unit (RC7001SA) 1
 Dimensions (Width × Height × Depth) 48 × 25.7 × 145mm
 Net weight (without Batteries) 160g
- AAA (R03) Batteries 2
- AC Power cord 1
- Audio cable 1 pairs
- Remote connection Cable 1
- User's Guide 1

Dimensions (unit: mm)

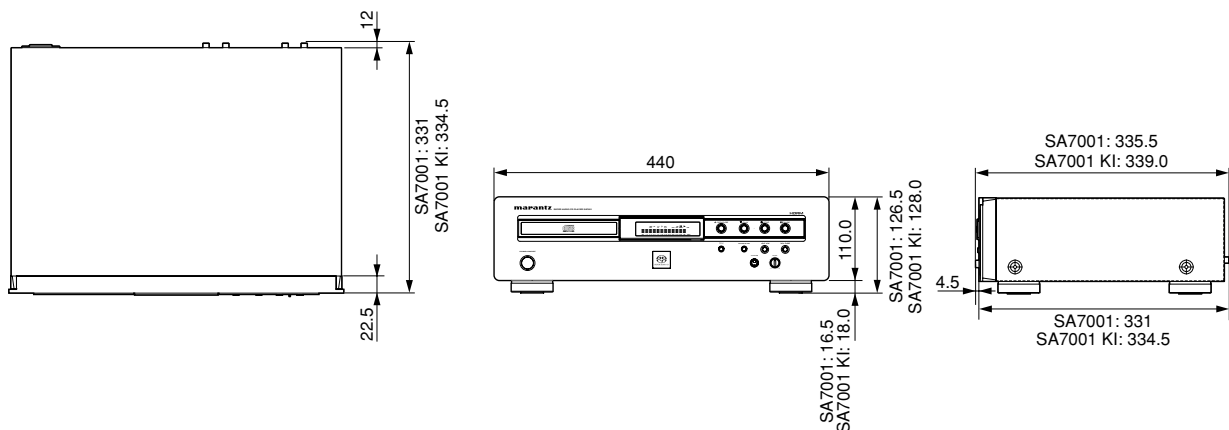

UPDATE DISC

Update of the CPU (IC731)..... 90M-SA7001DVR

2. SERVICE HINTS AND TOOLS

SERVICE HINTS

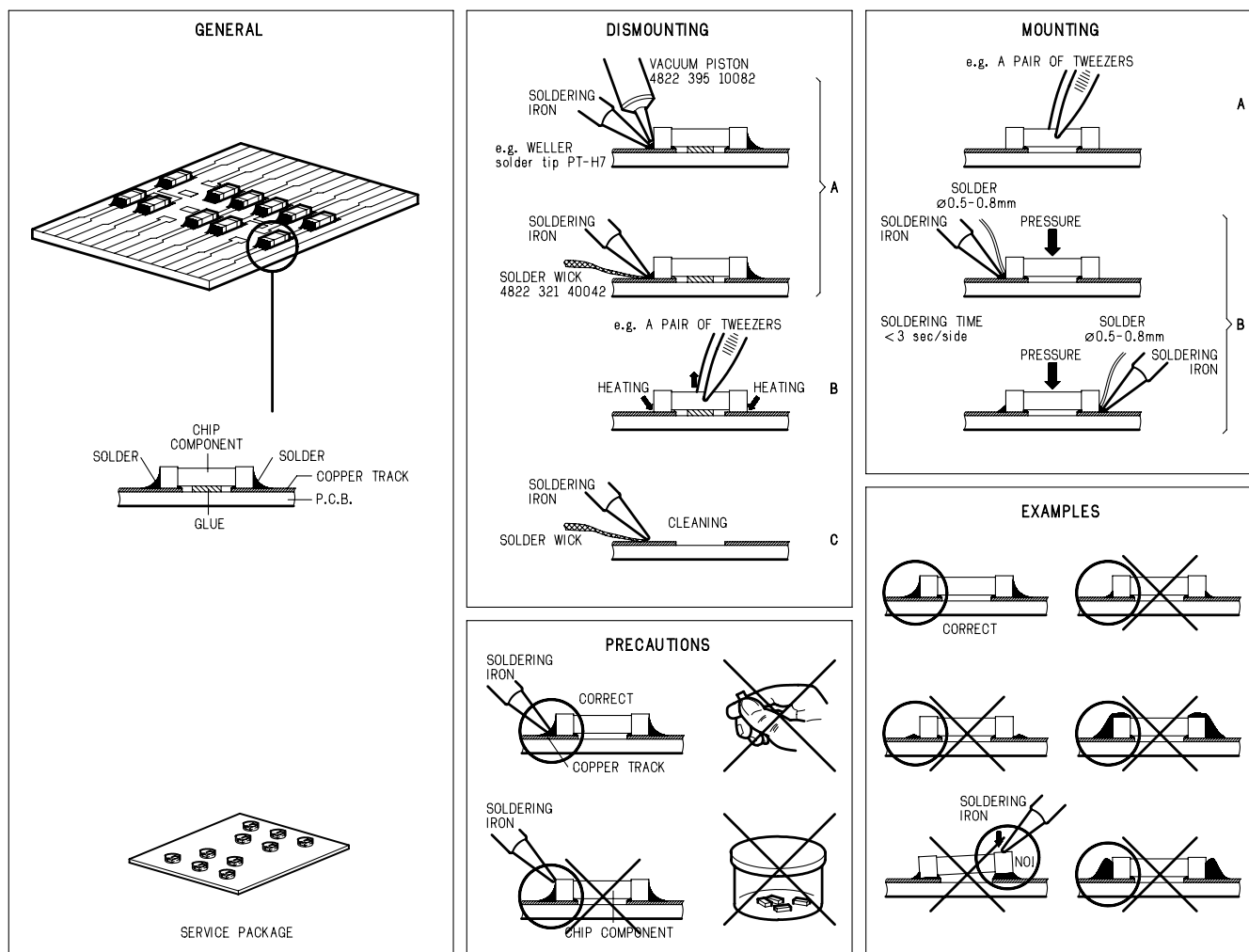

SERVICE TOOLS

Audio signals disc	4822 397 30184
Disc without errors (SBC444)+	
Disc with DO errors, black spots and fingerprints (SBC444A)	4822 397 30245
Disc (65 min 1kHz) without no pause	4822 397 30155
Max. diameter disc (58.0 mm)	4822 397 60141
Torx screwdrivers	
Set (straight)	4822 395 50145
Set (square)	4822 395 50132
13th order filter	4822 395 30204
DVD test disc (PAL)	4822 397 10131
DVD test disc (NTSC) ALMEDIO	TDV-540

3. WARNING AND LASER SAFETY INSTRUCTIONS

(GB) WARNING

All ICs and many other semi-conductors are susceptible to electrostatic discharges (ESD). Careless handling during repair can reduce life drastically.

When repairing, make sure that you are connected with the same potential as the mass of the set via a wrist wrap with resistance.

Keep components and tools also at this potential.

ESD



(NL) WAARSCHUWING

Alle IC's en vele andere halfgeleiders zijn gevoelig voor elektrostatische ontladingen (ESD).

Onzorgvuldig behandelen tijdens reparatie kan de levensduur drastisch doen verminderen.

Zorg ervoor dat u tijdens reparatie via een polsband met weerstand verbonden bent met hetzelfde potentiaal als de massa van het apparaat.

Houd componenten en hulpmiddelen ook op ditzelfde potentiaal.

(F) ATTENTION

Tous les IC et beaucoup d'autres semi-conducteurs sont sensibles aux décharges statiques (ESD).

Leur longévité pourrait être considérablement écourtée par le fait qu'aucune précaution n'est prise à leur manipulation.

Lors de réparations, s'assurer de bien être relié au même potentiel que la masse de l'appareil et enfilez le bracelet muni d'une résistance de sécurité.

Veillez à ce que les composants ainsi que les outils que l'on utilise soient également à ce potentiel.

(D) WARNUNG

Alle IC und viele andere Halbleiter sind empfindlich gegen elektrostatische Entladungen (ESD).

Unvorsichtige Behandlung bei der Reparatur kann die Lebensdauer drastisch vermindern. Sorgen sie dafür, das Sie im Reparaturfall über ein Pulsarmband mit Widerstand mit dem Massepotential des Gerätes verbunden sind.

Halten Sie Bauteile und Hilfsmittel ebenfalls auf diesem Potential.

(I) AVVERTIMENTO

Tutti IC e parecchi semi-conduttori sono sensibili alle scariche statiche (ESD).

La loro longevità potrebbe essere fortemente ridotta in caso di non osservazione della più grande cauzione alla loro manipolazione.

Durante le riparazioni occorre quindi essere collegato allo stesso potenziale che quello della massa dell'apparecchio tramite un braccialetto a resistenza.

Assicurarsi che i componenti e anche gli utensili con quali si lavora siano anche a questo potenziale.

(GB)

Safety regulations require that the set be restored to its original condition and that parts which are identical with those specified be used.

(NL)

Veiligheidsbepalingen vereisen, dat het apparaat in zijn oorspronkelijke toestand wordt terug gebracht en dat onderdelen, identiek aan de gespecificeerde worden toegepast.

(D)

Bei jeder Reparatur sind die geltenden Sicherheitsvorschriften zu beachten. Der Originalzustand des Gerats darf nicht verändert werden. Für Reparaturen sind Original-Ersatzteile zu verwenden.

(I)

Le norme di sicurezza esigono che l'apparecchio venga rimesso nelle condizioni originali e che siano utilizzati pezzi di ricambio identici a quelli specificati.

Pour votre sécurité, ces documents doivent être utilisés par des spécialistes agréés, seuls habilités à réparer votre appareil en panne.

(F)

Les normes de sécurité exigent que l'appareil soit remis à l'état d'origine et que soient utilisées les pièces de rechange identiques à celles spécifiées.

LASER SAFETY

This unit employs a laser. Only a qualified service person should remove the cover or attempt to service this device, due to possible eye injury.



USE OF CONTROLS OR ADJUSTMENTS OR PERFORMANCE OF PROCEDURE OTHER THAN THOSE SPECIFIED HEREIN MAY RESULT IN HAZARDOUS RADIATION EXPOSURE.

AVOID DIRECT EXPOSURE TO BEAM

WARNING

The use of optical instruments with this product will increase eye hazard.

Repair handling should take place as much as possible with a disc loaded inside the player

WARNING LOCATION: INSIDE ON LASER COVERSIELD

CAUTION VISIBLE AND INVISIBLE LASER RADIATION WHEN OPEN AVOID EXPOSURE TO BEAM
ADVARSEL SYNLIG OG USYNLIG LASERSTRÅLING VED ÅBNING UNDGÅ UDSÆTTELSE FOR STRÅLING
ADVARSEL SYNLIG OG USYNLIG LASERSTRÅLING NÅR DEKSEL Å PNES UNNGÅ EKSPONERING FOR STRÅLEN
VARNING SYNLIG OCH OSYNLIG LASERSTRÅLNING NÅR DENNA DEL ÅR ÖPPNAD BETRakta EJ STRÅLEN
VARO! AVATT AESSA OLET ALTTIINA NÄKYVÄLLE JA NÄKYMÄTTÖMÄLLE LASER SÄTEILYLLE. ÄLÄ KATSO SÄTEESEEN
VORSICHT SICHTBARE UND UNSICHTBARE LASERSTRAHLUNG WENN ABDECKUNG GEÖFFNET NICHT DEM STRAHL AUSSETZEN
DANGER VISIBLE AND INVISIBLE LASER RADIATION WHEN OPEN AVOID DIRECT EXPOSURE TO BEAM
ATTENTION RAYONNEMENT LASER VISIBLE ET INVISIBLE EN CAS D'OUVERTURE EXPOSITION DANGEREUSE AU FAISCEAU

4. TAKING THE DISC OUT OF EMERGENCY

1. To open the stucked tray, insert a pin into the eject pinhole and push the eject lever.
2. Use a pin $\phi 6\text{mm}$ or less.

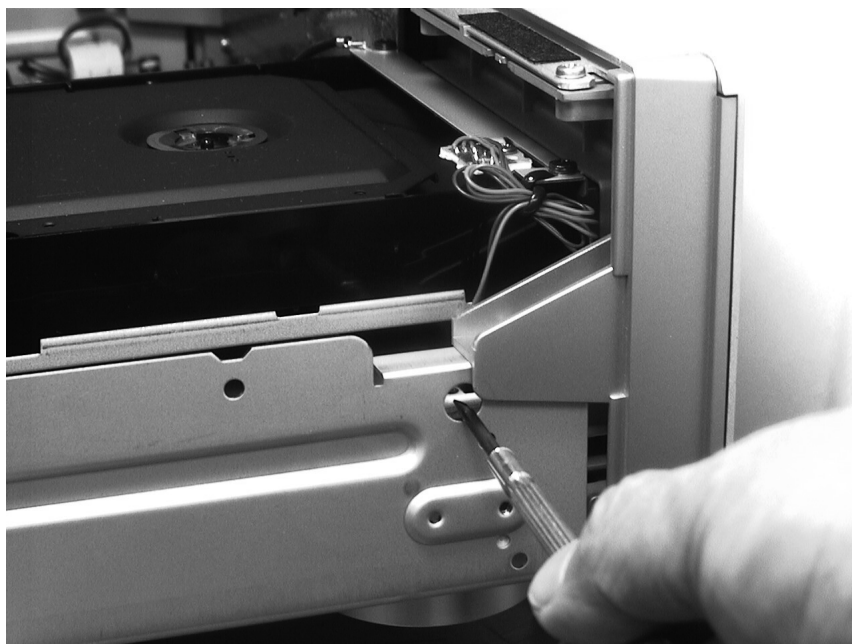

This picture shows the unit upside down. The eject lever is pointed by the arrow. The lever is thin so aim the narrow area carefully.

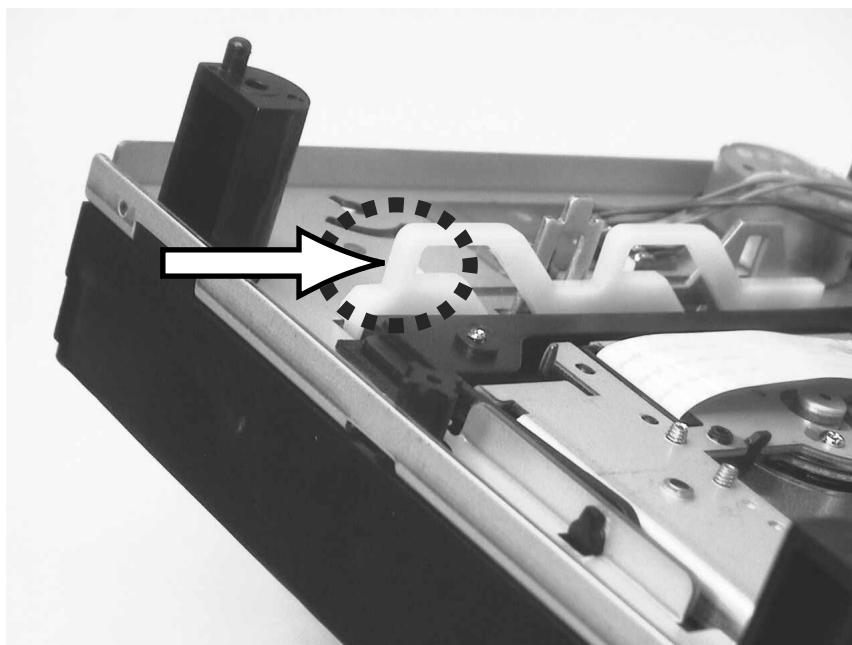

5. UPDATE FIRMWARE

Have UPDATE DISC. (90M-SA7001DVR)

Attention : Don't turn off the unit until disc tray opens automatically during the updating. When the turn off the unit halfway, The unit can't be operated any more.

1. Press the **POWER** button while pressing the **PLAY** and **OPEN/CLOSE** buttons.
2. Press the **OPEN/CLOSE** button to open the tray, Insert the update DVD-ROM (part No.:90M-SA7001DVR).
3. Press the **SOUND MODE** and **STOP** buttons.
The Display indicates " VERSION UP ".
4. Press the **OPEN/CLOSE** button to close the tray.
The Display indicates " TOC Reading " >>> " FILE CHECK " >>> " ERASE " >>> " WRITING ".
5. Software updating will be done automatically.
When the updating is finished, The disc tray opens automatically.
(Updating takes about 1 minute.)
6. Remove the DVD-ROM from the disc tray.

Update is completed, Press the **POWER** button to turn off the unit.

ファームウェアのアップデート方法

必要な物 : UPDATE DISC. (90M-SA7001DVR)

注意) 書き換え中は、ディスクトレイが自動的にオープンするまで絶対にセットの電源を切らないで下さい。途中で電源を切ると通常の動作も出来なくなります。

1. **PLAY** と **OPEN/CLOSE** ボタンを押しながら **POWER** ボタンを押します。
2. **OPEN/CLOSE** ボタンを押し、トレイをオープンします。
アップデート DVD-ROM (部品番号 90M-SA7001DVR) を挿入します。
3. **SOUND MODE** と **STOP** ボタンを同時に押します。
表示部には " VERSION UP " と表示されます。
4. **OPEN/CLOSE** ボタンを押します。トレイが閉じます。
表示部には " TOC Reading " >>> " FILE CHECK " >>> " ERASE " >>> " WRITING " の順に表示されます。 .
5. ソフトの書き換えは自動的に行われます。書き換えが終了するとディスクトレイは自動的にオープンします。
(アップデートには約 1 分かかります。)
6. ディスクトレイから DVD-ROM を取り出します。

以上で、ソフトウェアのアップデートは完了です。**POWER** ボタンを押して電源を切ります。

6. SERVICE MODE

The error code is indicated when a problem DISC is inserted first.

Press the **POWER** button While pressing **PLAY** and **OPEN/CLOSE** button

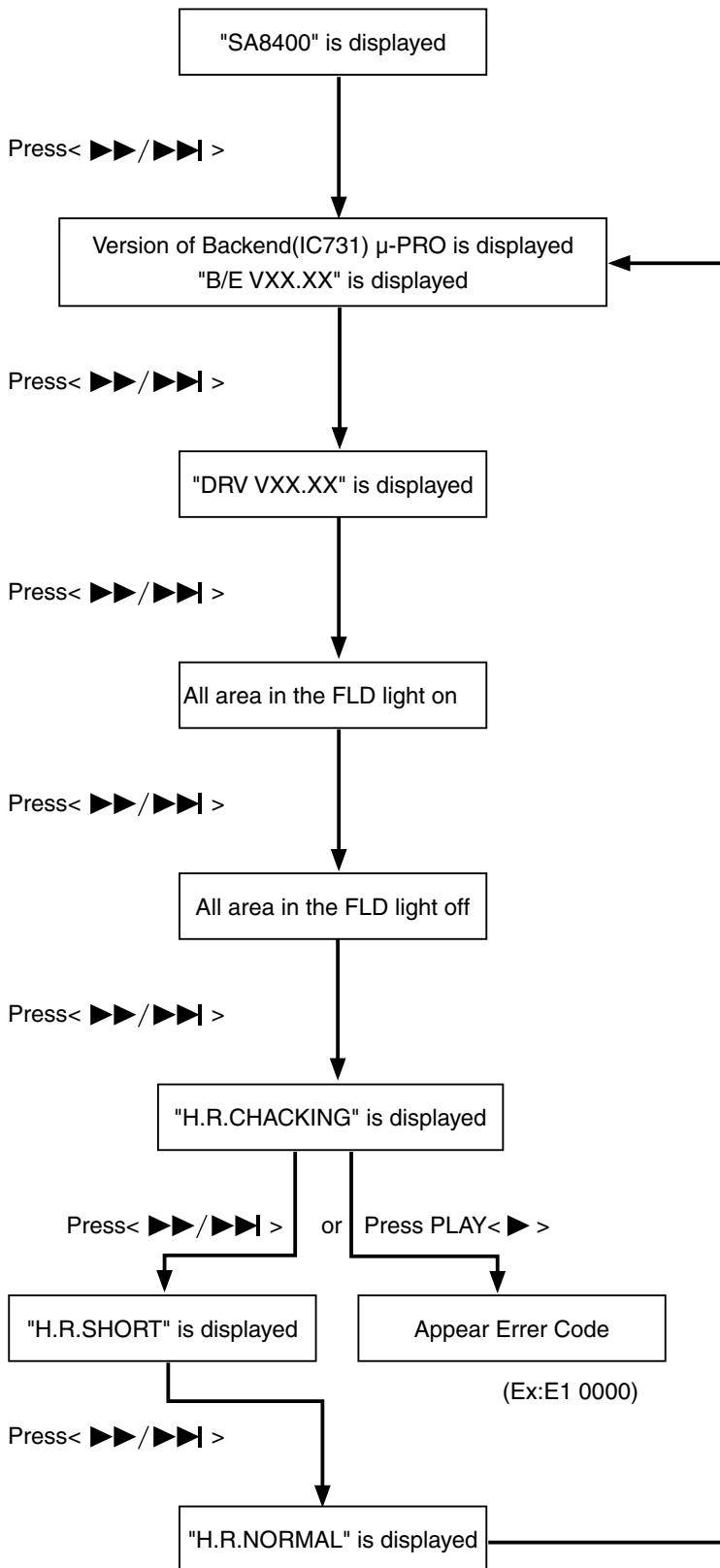

Remove Mains cord from plug

Error Code

Error Code	Error
E1 XXXX	Operation time Error
E2 XXXX	T.O.C Error
E2 XXXX	Focus Error
E2 XXXX	Read Error
E4 XXXX	Tracking Error
E5 XXXX	Tray Error
E6 XXXX	Navigation Pack Read Error
E7 XXXX	Check Sum Error and NonAcknow Idgmen
NO DISC XXXX	NO disc

(XXXX: The Operation number of times to the error occurrence)

7. BLOCK DIAGRAM

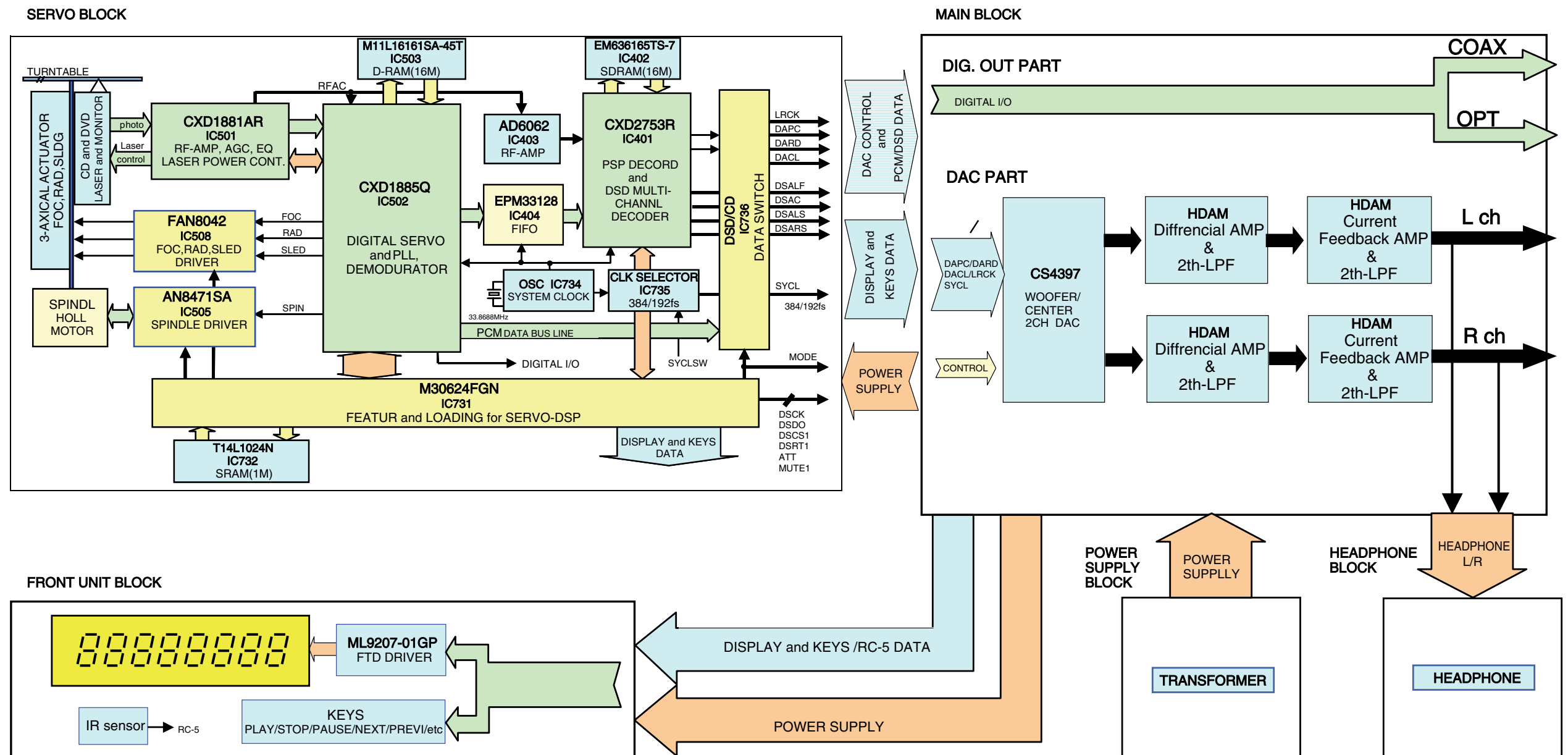

8. SCHEMATIC DIAGRAM

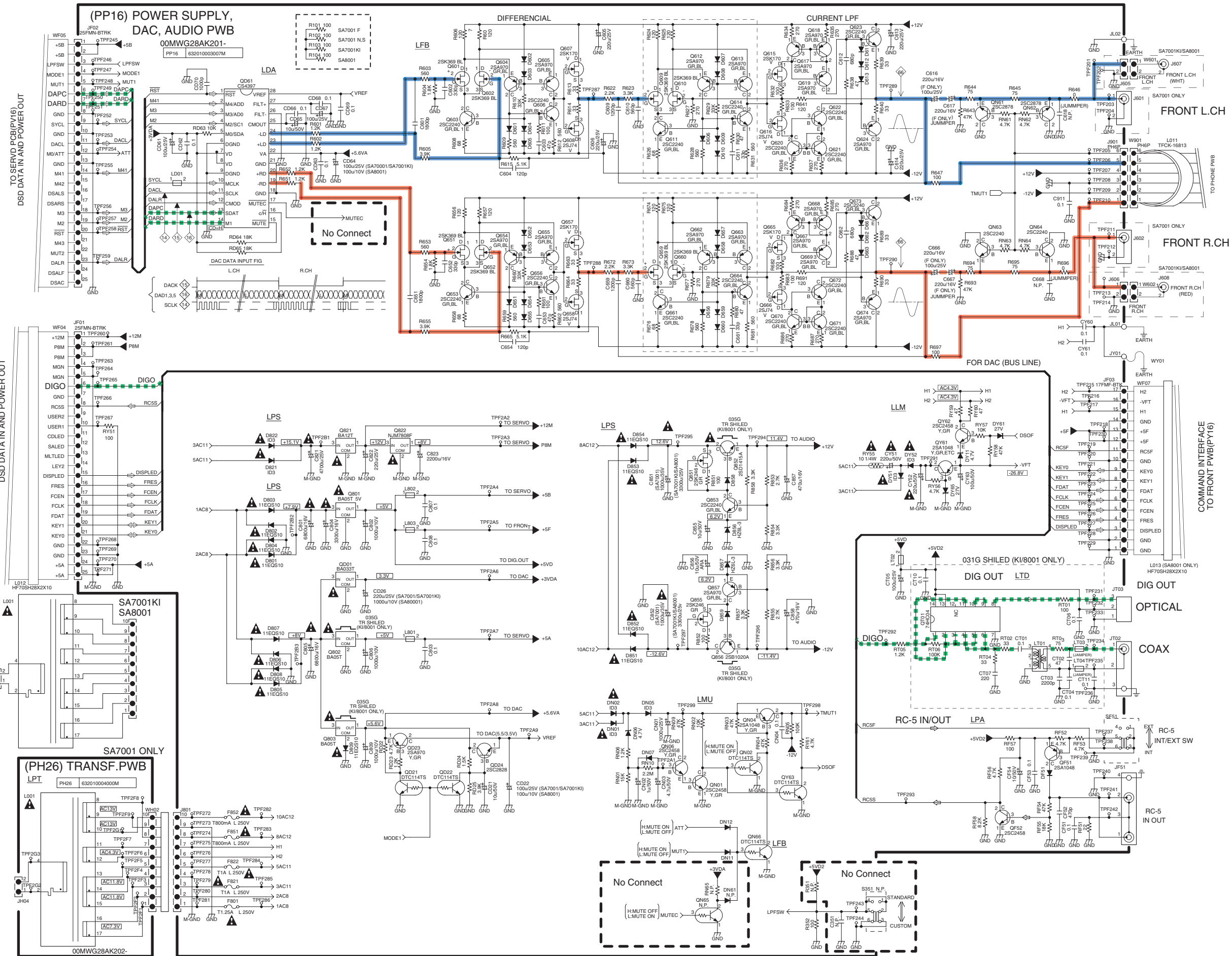

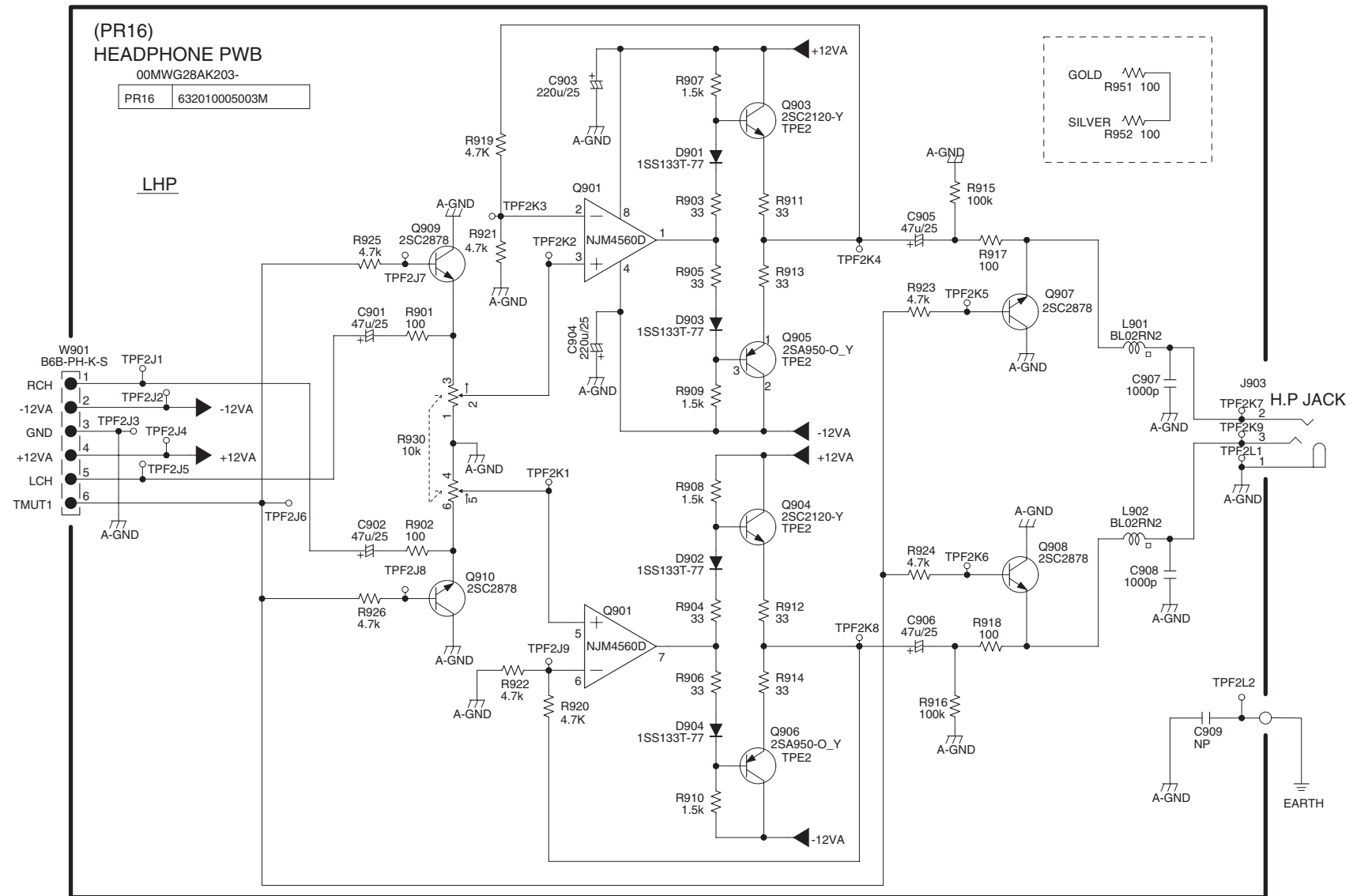

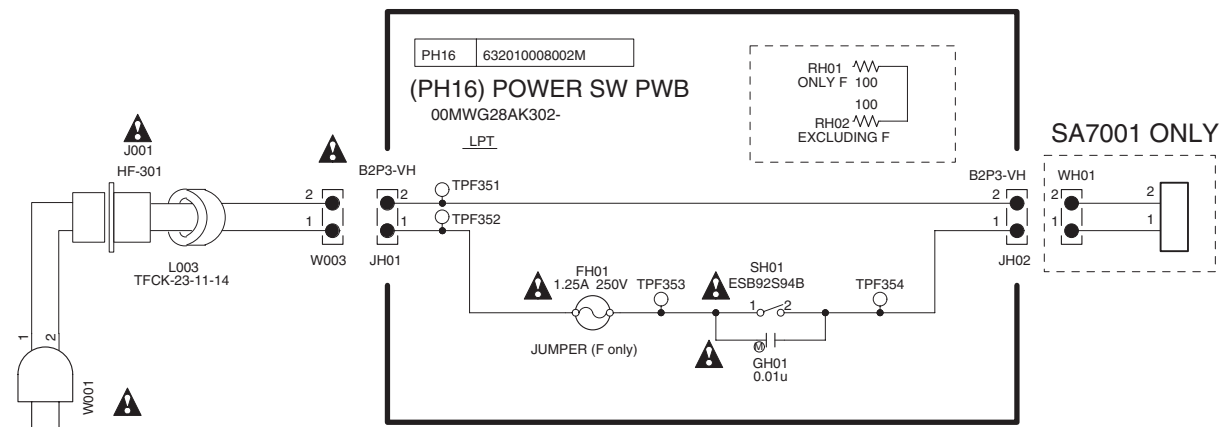
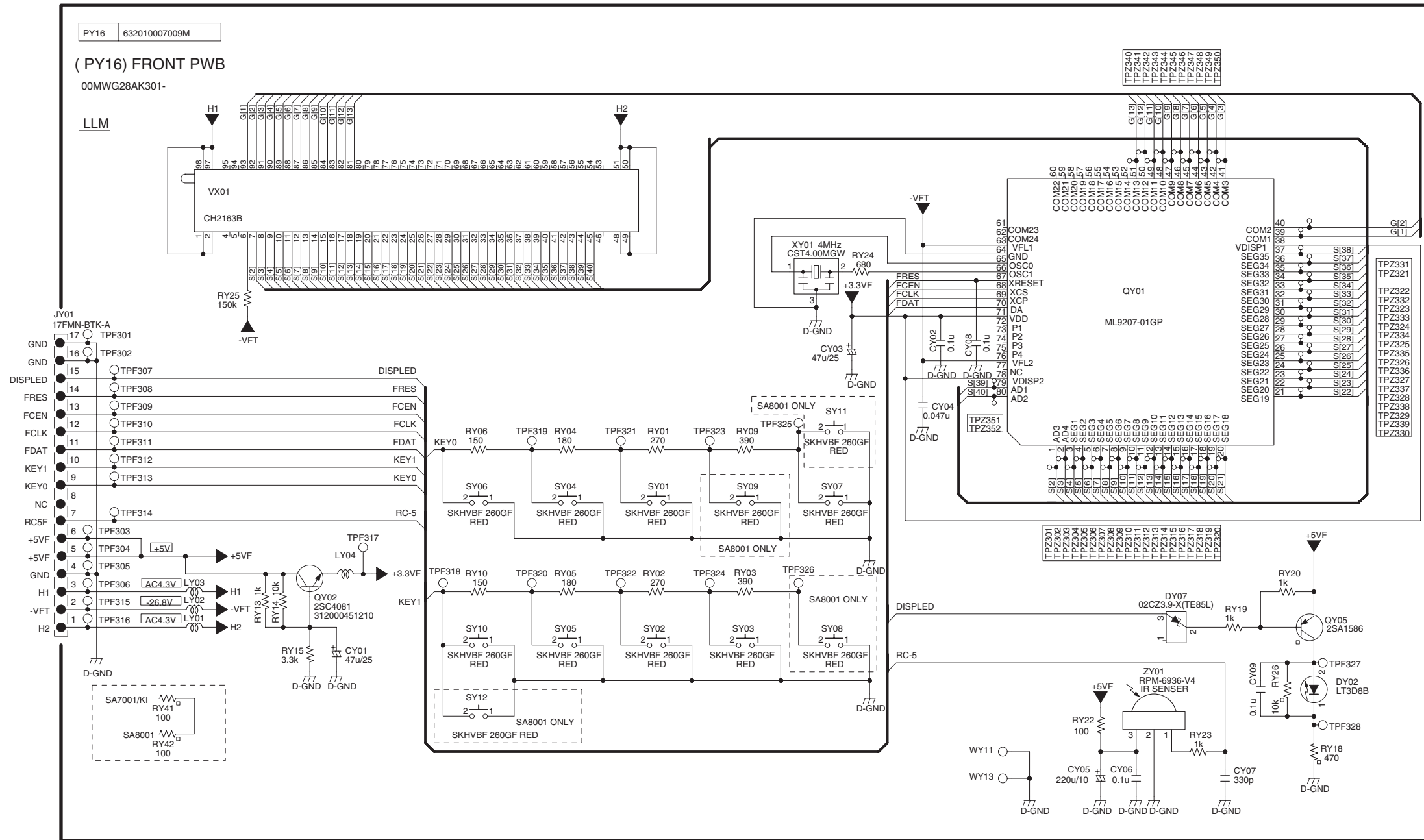

9. PARTS LOCATION

PH16 B

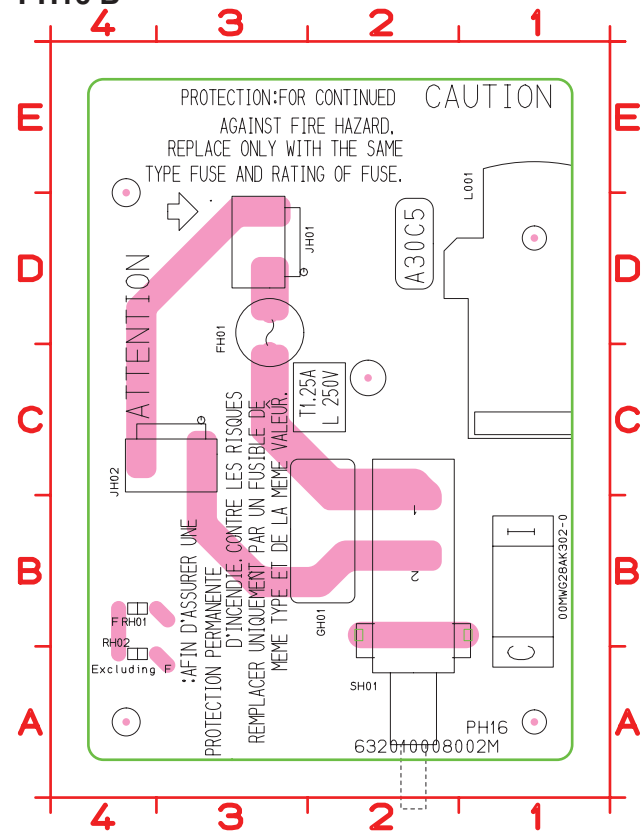

FH01	C3
GH01	B2
JH01	D3
JH02	C3
RH01	B4
RH02	A4
SH01	B2

PY16 A

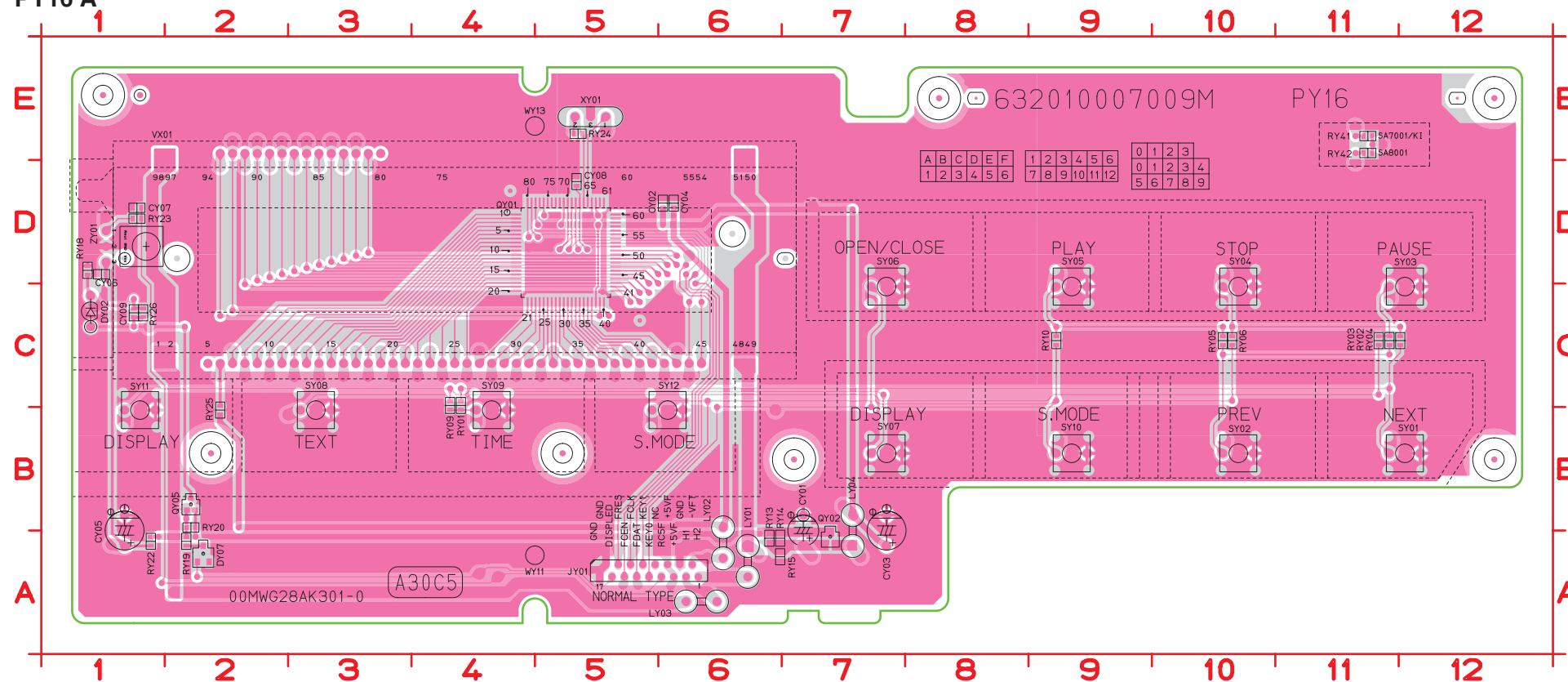

CY01	A7	RY01	C4	RY41	E11
CY02	D6	RY02	C11	RY42	E11
CY03	A7	RY03	C11	SY01	B12
CY04	D6	RY04	C12	SY02	B10
CY05	A1	RY05	C10	SY03	C12
CY06	D1	RY06	C10	SY04	C10
CY07	D1	RY09	C4	SY05	C9
CY08	D5	RY10	C9	SY06	C7
CY09	C1	RY13	A6	SY07	B7
DY02	C1	RY14	A6	SY08	B3
DY07	A2	RY15	A6	SY09	B4
JY01	A6	RY18	D1	SY10	B9
LY01	A6	RY19	A2	SY11	B1
LY02	A6	RY20	B2	SY12	B6
LY03	A6	RY22	A1	VX01	D4
LY04	A7	RY23	D1	WY11	A5
QY01	D5	RY24	E5	XY01	E5
QY02	A7	RY25	B2	XY01	E5
QY05	B2	RY26	C1	ZY01	D1

鉛フリー半田

半田付けには、鉛フリー半田 (Sn-Ag-Cu) を使用してください。

Lead-free Solder

When soldering, use the Lead-free Solder (Sn-Ag-Cu).

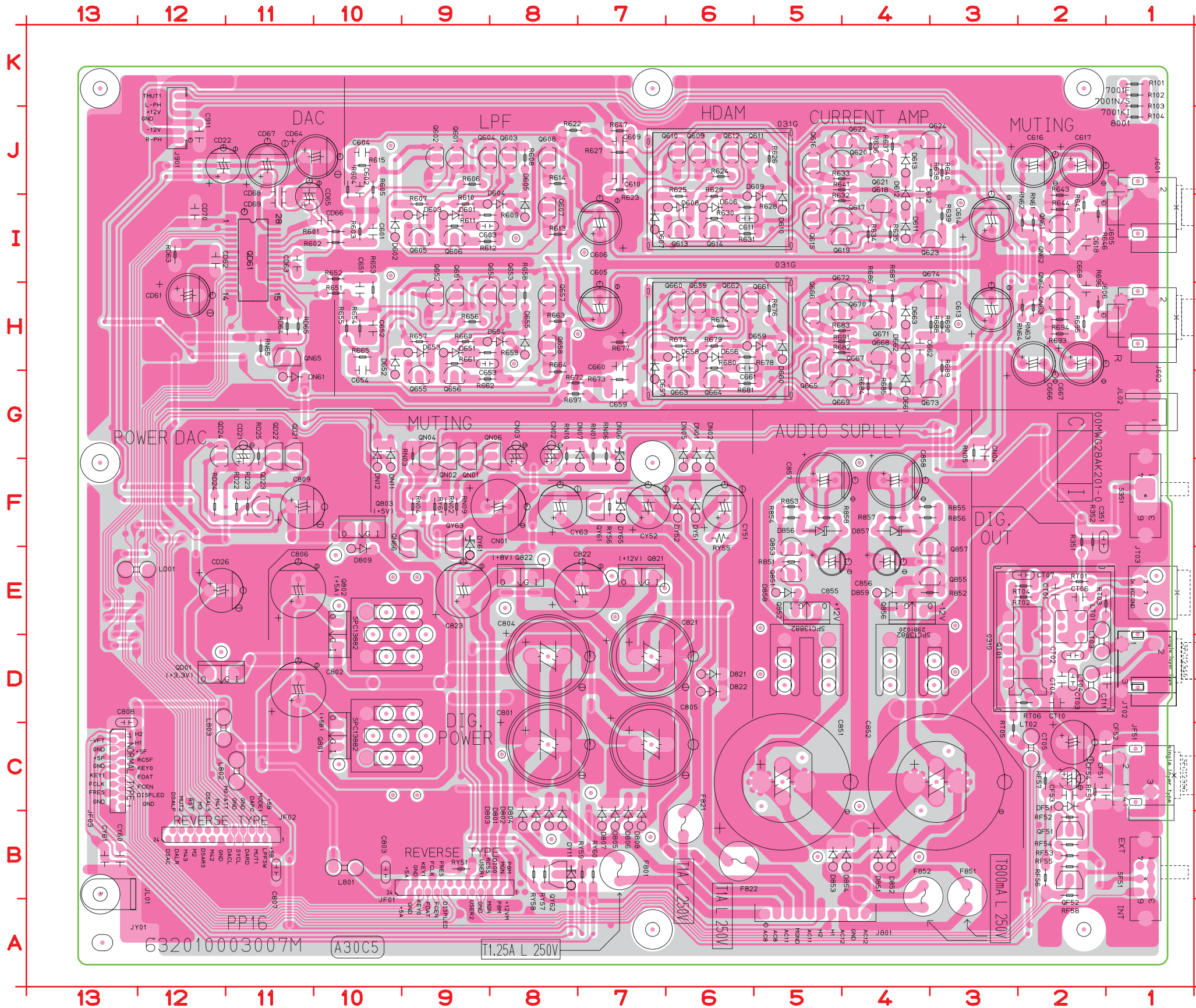

C351	E2	CD61	H12	D655	H8
C601	I10	CD62	I12	D656	H6
C602	J10	CD63	I11	D657	G7
C603	I8	CD64	J11	D658	H6
C604	J10	CD65	I11	D659	H6
C605	H7	CD66	I10	D660	H5
C606	I7	CD67	J11	D661	G4
C609	J7	CD68	J11	D662	H4
C610	J7	CD69	I11	D663	H4
C611	I5	CD70	I12	D801	B8
C612	I4	CF51	C2	D802	B8
C613	H3	CF52	C2	D803	B8
C614	I3	CF53	C2	D804	B8
C616	J2	CF54	C2	D805	B7
C617	J2	CN01	F9	D806	B7
C618	I2	CN02	F8	D807	B7
C651	H10	CN03	F8	D808	B7
C652	H10	CN04	F3	D809	E10
C653	H8	CT01	E2	D821	D6
C654	H10	CT02	D2	D822	D6
C659	G7	CT03	D2	D851	B4
C660	H7	CT04	D2	D852	B4
C661	H5	CT05	C2	D853	B5
C662	H4	CT06	E2	D854	B4
C666	H2	CT07	E3	D856	F5
C667	H2	CT10	D2	D857	F4
C668	H2	CT11	D1	D858	E5
C801	C8	CY51	F6	D859	E4
C802	D11	CY52	F7	DF51	C2
C803	B10	CY60	B13	DN01	F6
C804	D8	CY61	B13	DN02	F6
C805	C7	CY63	F8	DN05	F6
C806	E11	D601	I9	DN06	F7
C807	B11	D602	I10	DN07	F7
C808	D13	D603	I9	DN11	F10
C809	F11	D604	I9	DN12	F10
C821	D7	D605	I8	DN61	G11
C822	E7	D606	I6	DY11	B8
C823	E9	D607	I7	DY51	F6
C851	C5	D608	I6	DY52	F6
C852	C4	D609	I6	DY61	E9
C855	E5	D610	I5	DY65	F7
C856	E4	D611	I4	F801	B7
C857	F5	D612	I4	F821	B6
C858	F4	D613	J4	F822	B6
C911	J12	D651	H9	F851	A3
CD21	F11	D652	G10	F852	A4
CD22	J12	D653	H9	J601	I1
CD26	E12	D654	H9	J602	H1

鉛フリー半田
 半田付けには、鉛フリー半田 (Sn-Ag-Cu) を使用してください。
Lead-free Solder
 When soldering, use the Lead-free Solder (Sn-Ag-Cu).

PP16 B

J605	I1	Q655	G9	QT01	D3	R647	J7	RD22	F11
J606	H1	Q656	G9	QY61	F7	R651	H10	RD23	F11
J801	A5	Q657	H8	QY62	B8	R652	I10	RD24	F12
J901	J12	Q658	H8	QY63	F9	R653	H10	RD25	F11
JF01	B8	Q659	H6	R101	K1	R654	H10	RD63	I12
JF02	B11	Q660	H6	R102	K1	R655	H10	RD64	H11
JF03	C13	Q661	H6	R103	K1	R656	H9	RD65	H11
JF51	C1	Q662	H6	R104	J1	R657	H9	RF51	C2
JL01	B13	Q663	G6	R351	E2	R658	H8	RF52	B2
JL02	G1	Q664	G6	R352	E2	R659	H8	RF53	B2
JT02	D1	Q665	H5	R601	I10	R660	H9	RF54	B2
JT03	E1	Q666	H5	R602	I10	R661	H9	RF55	B2
JY01	A12	Q667	H5	R603	I10	R662	G8	RF56	B2
L801	B10	Q668	H4	R604	I10	R663	H8	RF57	C2
L802	C11	Q669	G5	R605	I10	R664	G8	RF58	B2
L803	C12	Q670	H5	R606	J9	R665	H10	RN01	F7
LD01	E12	Q671	H4	R607	I9	R672	G7	RN02	F9
LT01	E2	Q672	H5	R608	J8	R673	G7	RN03	F9
LT02	C2	Q673	G3	R609	I8	R674	H6	RN04	F9
LT03	D2	Q674	H3	R610	I9	R675	H6	RN05	F3
LT04	D2	Q801	C10	R611	I9	R676	H5	RN06	F7
Q601	J9	Q802	E10	R612	I8	R677	H7	RN09	F9
Q602	J9	Q803	F10	R613	I8	R678	H5	RN10	F8
Q603	J8	Q821	E7	R614	J8	R679	H6	RN61	I2
Q604	J9	Q822	E8	R615	J10	R680	H6	RN62	I2
Q605	I9	Q851	E5	R622	J7	R681	G5	RN63	H2
Q606	I9	Q852	E5	R623	J7	R682	H4	RN64	H2
Q607	I8	Q853	E5	R624	J6	R683	H4	RN65	H11
Q608	J8	Q855	E4	R625	I6	R684	G4	RT01	E2
Q609	J6	Q856	E4	R626	J5	R685	G4	RT02	E3
Q610	J6	Q857	E4	R627	J7	R686	H4	RT03	E2
Q611	J6	QD01	D12	R628	I5	R687	H4	RT04	E3
Q612	J6	QD21	G11	R629	I6	R688	H3	RT05	C3
Q613	I6	QD22	G11	R630	I6	R689	G3	RT06	D2
Q614	I6	QD23	F11	R631	I5	R690	H3	RY51	B9
Q615	I5	QD24	G12	R632	I4	R691	H4	RY55	F6
Q616	J5	QD61	I11	R633	J4	R693	H2	RY56	F7
Q617	I5	QF51	B2	R634	I4	R694	H2	RY57	B8
Q618	I4	QF52	B2	R635	I4	R695	H2	RY58	B8
Q619	I5	QN01	G9	R636	J4	R696	H2	RY59	B7
Q620	J5	QN02	G9	R637	J4	R697	G7	RY60	B7
Q621	J4	QN04	G9	R638	J3	R851	E5	RY61	F9
Q622	J5	QN06	G8	R639	I3	R852	E3	S351	F1
Q623	I3	QN61	I2	R640	J3	R853	F5	SF51	B1
Q624	J3	QN62	I2	R641	J4	R854	F5		
Q651	H9	QN63	H2	R643	I2	R855	F4		
Q652	H9	QN64	I2	R644	I2	R856	F4		
Q653	H8	QN65	H11	R645	I2	R857	F4		
Q654	H9	QN66	F9	R646	I2	R858	F5		

PR16 B

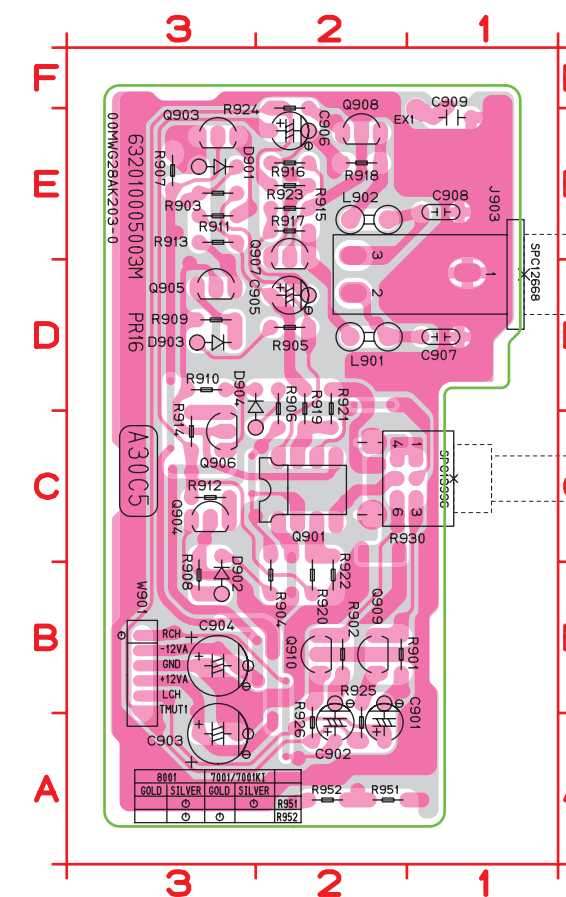

C901	A2	Q910	B2	R925	A2
C902	A2	R901	B2	R926	A2
C903	A3	R902	B2	R930	C1
C904	B3	R903	E3	R951	A2
C905	D2	R904	B2	R952	A2
C906	E2	R905	D2	W901	B3
C907	D1	R906	C2		
C908	E1	R907	E3		
C909	E1	R908	B3		
D901	E3	R909	D3		
D902	B3	R910	D3		
D903	D3	R911	E3		
D904	C3	R912	C3		
EX1	E1	R913	E3		
J903	D1	R914	C3		
L901	D2	R915	E2		
L902	E2	R916	E2		
Q901	C2	R917	E2		
Q903	E3	R918	E2		
Q904	C3	R919	C2		
Q905	D3	R920	B2		
Q906	C3	R921	C2		
Q907	E2	R922	B2		
Q908	E2	R923	E2		
Q909	B2	R924	F2		

鉛フリー半田
 半田付けには、鉛フリー半田 (Sn-Ag-Cu) を使用してください。
Lead-free Solder
 When soldering, use the Lead-free Solder (Sn-Ag-Cu).

10. MICROPROCESSOR AND IC DATA

QY01 : ML9207-01

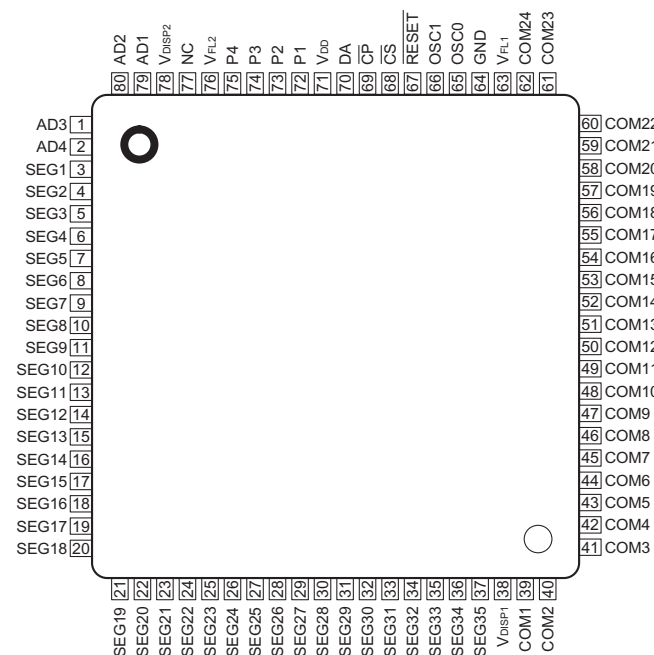

ML9207-01 Terminal Function

Pin No.	Pin Name	I/O	Function
3~37	SEG1~35	O	FL display anode drive output pin
39~62	COM1~24	O	FL display grid drive output pin
1,2, 79, 80	AD1~4	O	FL display anode drive output pin
72~75	P1~4	O	General port output pin
71	VDD		VDD-GND: Power supply for logic block V _{DISP} -V _{FL} : Power supply for FL display drive For VDD and V _{DISP} , apply from same power source
38, 78	V _{DISP1-2}		
64	GND		
63, 76	V _{FL1-2}		
70	DA	I	Serial data input pin (positive logic)
69	CP	I	Shift clock input pin
68	CS	I	Chip select input pin
67	RESET	I	Reset input pin
65	OSC0	I	Pin for self-oscillation
66	OSC1	O	

QD61 : CS4397

PCM MODE

Function	Pin	Pin	Function	Description
Reset	RST	1	VREF	Voltage Reference
See Description	M4(AD0/CS)	2	FILT+	Reference Filter
See Description	M3(AD1/CDIN)	3	FILT-	Reference Ground
See Description	M2(SCL/CCLK)	4	CMOUT	Common ModeS Voltage
See Description	M0(SDA/CDOUT)	5	AOUTL-	Differential Output
Digital Ground	DGND	6	AOUTL+	Differential Output
Digital Power	VD	7	VA	Analog Power
Digital Power	VD	8	AGND	Analog Ground
Digital Ground	DGND	9	AOUTR+	Differential Output
Master Clock	MCLK	10	AOUTR-	Differential Output
Serial Clock	SCLK	11	AGND	Analog Ground
Left/Right Clock	LRCK	12	MUTE	Mute Control
Serial Data	SDATA	13	C/H	Control port/Hardware select
See Description	M1	14	MUTE	Soft Mute

Reset - RST

Pin 1, Input

Function:

The device enters a low power mode and all internal state machines registers are reset when low. When high, the device will be in a normal operation mode .

RST	DESCRIPTION
0	Enabled
1	Normal operation mode

Digital Ground - DGND

Pins 6 and 9, Inputs

Function:

Digital ground reference.

Digital Power - VD

Pins 7 and 8, Input

Function:

Digital power supply. Typically 5.0 to 3.0 VDC.

Master Clock - MCLK

Pin 10, Input

Function:

The master clock frequency must be either 256x, 384x, 512x or 768x the input sample rate in Single Speed Mode; either 128x, 192x 256x or 384x the input sample rate in Double Speed Mode; or 64x, 96x 128x or 192x the input sample rate in Quad Speed Mode. Tables 4-6 illustrate the standard audio sample rates and the required master clock frequencies.

Sample Rate (kHz)	MCLK (MHz)			
	256x	384x	512x	768x
32	8.1920	12.2880	16.3840	24.5760
44.1	11.2896	16.9344	22.5792	33.8688
48	12.2880	18.4320	24.5760	36.8640

Table 4. Single Speed (16 to 50 kHz sample rates) Common Clock Frequencies

Serial Clock - SCLK

Pin 11, Input

Function:

Clocks individual bits of serial data into the SDATA pin. The required relationship between the Left/Right clock, serial clock and serial data is defined by either the Mode Control Byte in Control Port Mode or the M0 - M4 pins in Hardware Mode. The options are detailed in Figures 29-33

Left/Right Clock - LRCK

Pin 12, Input

Function:

The Left/Right clock determines which channel is currently being input on the serial audio data input, SDATA. The frequency of the Left/Right clock must be at the input sample rate. Audio samples in Left/Right sample pairs will be simultaneously output from the digital-to-analog converter whereas Right/Left pairs will exhibit a one sample period difference. The required relationship between the Left/Right clock, serial clock and serial data is defined by the Mode Control Byte and the options are detailed in Figures 29-33

Serial Audio Data - SDATA

Pin 13, Input

Function:

Serial audio data is input on this pin. The selection of the Digital Interface Format is determined by settings of the Mode select as detailed in Figures 29-33. The data is clocked into SDATA via the serial clock and the channel is determined by the Left/Right clock. The required relationship between the Left/Right clock, serial clock and serial data is defined by the Mode Control Byte and the options are detailed in Figures 29-33

Soft Mute - MUTE

Pin 15, Input

Function:

The analog outputs will ramp to a muted state when enabled. The ramp requires 1152 left/right clock cycles in Single Speed, 2304 cycles in Double Speed and 4608 cycles in Quad Speed mode. The bias voltage on the outputs will be retained and MUTE will go active at the completion of the ramp period.

The analog outputs will ramp to a normal state when this function transitions from the enabled to disabled state. The ramp requires 1152 left/right clock cycles in Single Speed, 2304 cycles in Double Speed and 4608 cycles in Quad Speed mode. The MUTE will release immediately on setting MUTE = 1. The converter analog outputs will mute when enabled. The bias voltage on the outputs will be retained and MUTE will go active during the mute period.

Mute	DESCRIPTION
0	Enabled
1	Normal operation mode

Control Port / Hardware Mode Select - C/H

Pin 16, Input

Function:

Determines if the device will operate in either the Hardware Mode or Control Port Mode.

C/H	DESCRIPTION
0	Hardware Mode Enabled
1	Control Port Mode Enabled

Mute Control - MUTE

Pin 17, Output

Function:

The Mute Control pin goes low during power-up initialization, reset, muting, master clock to left/right clock frequency ratio is incorrect or power-down. This pin is intended to be used as a control for an external mute circuit to prevent the clicks and pops that can occur in any single supply system. Use of Mute Control is not mandatory but recommended for designs requiring the absolute minimum in extraneous clicks and pops.

Analog Ground - AGND

Pins 18 and 21, Inputs

Function:

Analog ground reference.

Differential Analog Output - AOUL- , AOUL+ and AOUL- , AOUL+

Pins 19, 20, 23 and 24, Outputs

Function:

The full scale differential analog output level is specified in the Analog Characteristics specifications table.

Analog Power - VA

Pin 22, Input

Function:

Power for the analog and reference circuits. Typically 5VDC.

Common Mode Voltage - CMOUT

Pin 25, Output Function:

Filter connection for internal bias voltage, typically 50% of VREF. Capacitors must be connected from CMOUT to analog ground, as shown in Figure 6. CMOUT has a typical source impedance of 25 kΩ and any current drawn from this pin will alter device performance

Reference Ground - FILT-

Pin 26, Input Function:

Ground reference for the internal sampling circuits. Must be connected to analog ground.

Reference Filter - FILT+

Pin 27, Output Function:

Positive reference for internal sampling circuits. External capacitors are required from FILT+ to analog ground, as shown in Figure 6. FILT+ is not intended to supply external current.

Voltage Reference Input- VREF

Pin 28, Input Function:

Analog voltage reference. Typically 5VDC.

HARDWARE MODE

Mode Select - M0, M1, M2, M3, M4

Pins 2, 3, 4, 5 and 14, Inputs Function:

The Mode Select pins determine the operational mode of the device as detailed in Tables 9-14. The options include; Selection of the Digital Interface Format which determines the required relationship between the Left/Right clock, serial clock and serial data as detailed in Figures 29-33 Selection of the standard 15 μs/50 μs digital de-emphasis filter response, Figure 28, which requires re-configuration of the digital filter to maintain the proper filter response for 32, 44.1 or 48 kHz sample rates. Selection of the appropriate clocking mode to match the input sample rates. Access to the Direct Stream Digital Mode Access to the 8x Interpolation Input Mode

CONTROL PORT MODE

Address Bit 0 / Chip Select - AD0 / CS

Pin 2, Input Function:

In I²C mode, AD0 is a chip address bit. CS is used to enable the control port interface in SPI mode. The device will enter the SPI mode at anytime a high to low transition is detected on this pin. Once the device has entered the SPI mode, it will remain until either the part is reset or undergoes a power-down cycle.

Address Bit 1 / Control Data Input - AD1/CDIN

Pin 3, Input Function:

In I²C mode, AD1 is a chip address bit. CDIN is the control data input line for the control port interface in SPI mode.

Serial Control Interface Clock - SCL/CCLK

Pin 4, Input Function:

In I²C mode, SCL clocks the serial control data into or from SDA/CDOUT. In SPI mode, CCLK clocks the serial data into AD1/CDIN and out of SDA/CDOUT.

Serial Control Data I/O - SDA/CDOUT

Pin 5, Input/Output Function:

In I²C mode, SDA is a data input/output. CDOUT is the control data output for the control port interface in SPI mode.

M1 - Mode Select

Pin 14, Input Function:

This pin is not used in Control Port Mode and must be terminated to ground.

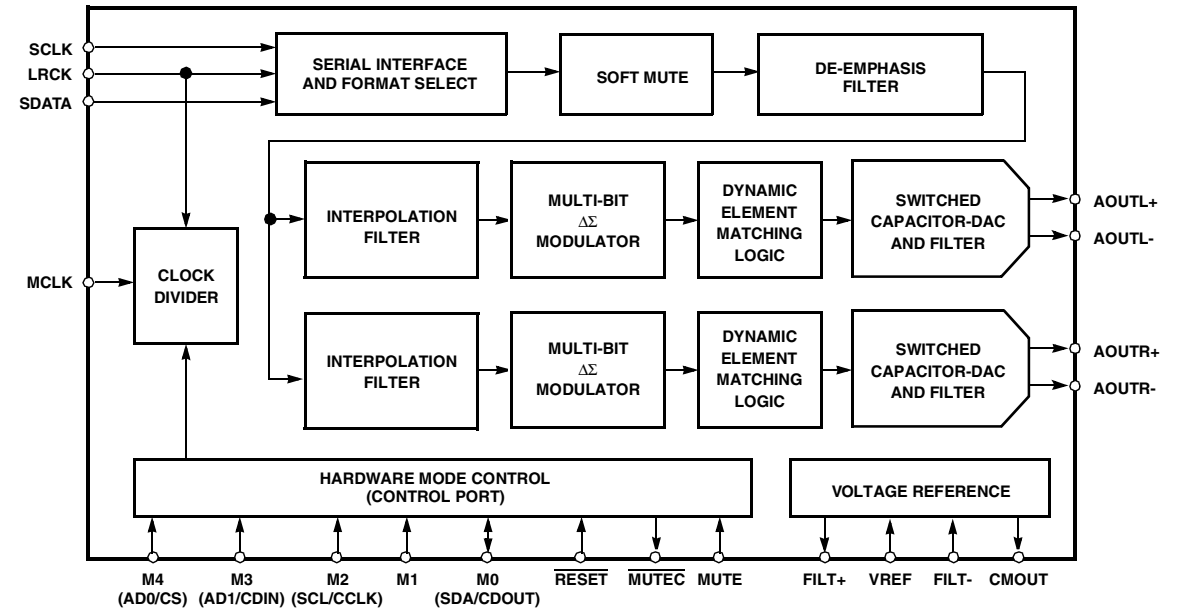

DSD MODE

Refer to PCM mode	RST	1	28	VREF	Refer to PCM mode
Refer to PCM mode	M4(ADO/CS)	2	27	FILT+	Refer to PCM mode
Refer to PCM mode	M3(AD1/CDIN)	3	26	FILT-	Refer to PCM mode
Refer to PCM mode	M2(SCL/CCLK)	4	25	CMOUT	Refer to PCM mode
Refer to PCM mode	M0(SDA/CDOUT)	5	24	AOUL-	Refer to PCM mode
Refer to PCM mode	DGND	6	23	AOUL+	Refer to PCM mode
Refer to PCM mode	VD	7	22	VA	Refer to PCM mode
Refer to PCM mode	VD	8	21	AGND	Refer to PCM mode
Refer to PCM mode	DGND	9	20	AOUL+	Refer to PCM mode
Master Clock	MCLK	10	19	AOUL-	Refer to PCM mode
DSD Serial Clock	DSD_SCLK	11	18	AGND	Refer to PCM mode
Master Clock Mode	CLKMODE	12	17	C/H	Refer to PCM mode
Left Channel Data	DSD_L	13	16	MUTE	Refer to PCM mode
Right Channel Data	DSD_R	14	15		Refer to PCM mode

Master Clock - MCLK

Pin 10, Input

Function:

The master clock frequency must be either 4x or 6x the DSD data rate for 64x oversampled DSD data and 2x or 3x the DSD data rate for 128x oversampled DSD data, refer to Table 7.

CLKMODE

Pin 12, Input

Function:

This pin determines the allowable Master Clock to DSD data ratio as defined in Table 7.

DSD Serial Clock -DSD_SCLK

Pin 11, Input

Function:

Clocks the individual bits of the DSD audio data into the DSD_L and DSD_R pins.

Audio Data -DSD_L and DSD_R

Pins 13 and 14, Inputs

Function:

Direct Stream Digital audio data is clocked into DSD_L and DSD_R via the DSD serial clock.

CLKMODE

DSD Over-Sampling Ratio		0	1
		64x	4x
128x		2x	3x

Table 7. MCLK to DSD Data Rate Clock Ratios

11. EXPLODED VIEW AND PARTS LIST

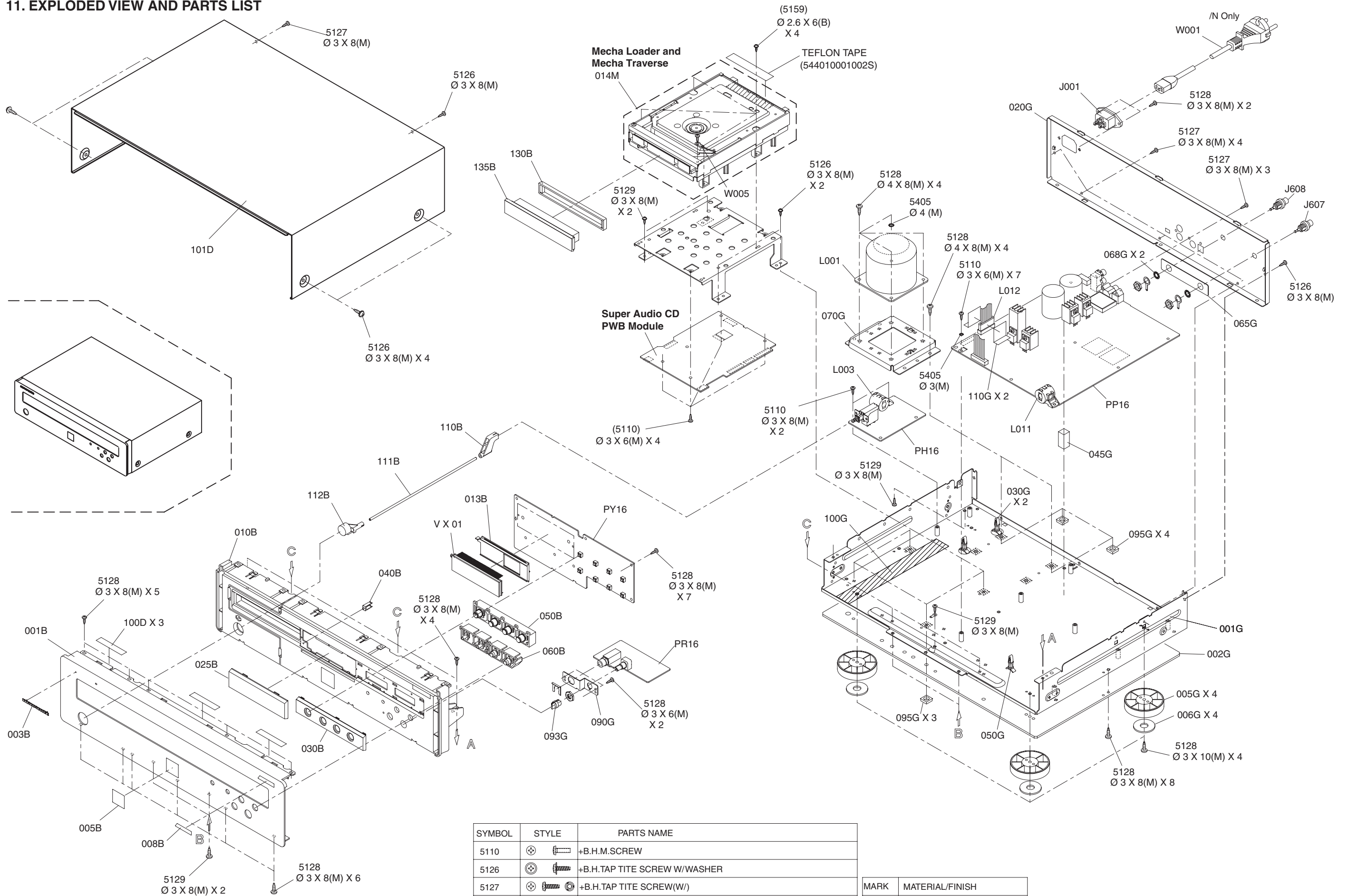

SYMBOL	STYLE	PARTS NAME
5110		+B.H.M.SCREW
5126		+B.H.TAP TITE SCREW W/WASHER
5127		+B.H.TAP TITE SCREW(W/)
5128		+B.H.TAP TITE SCREW(B TYPE)
5129		+B.H.TAP TITE SCREW(W/T.L.WASHER)
5405		TOOTHED LOCK WASHERS

MARK	MATERIAL/FINISH
(M)	STEEL/COPPER
(U)	STEEL/BLACK
(K)	STEEL/NICKEL

PWB NAME	POS. NO.	VERS. COLOR	PART NO. (FOR EUR)	PART NO. (MZ)	PART NAME	DESCRIPTION
	001B	/N1B	00M28AK248010	00M28AK248010	FRONT PANEL	FRONT AL PANEL SA7001 BL
	001B	/N1S	00M28AK248210	00M28AK248210	FRONT PANEL	FRONT AL PANEL SA7001 SL
	003B	/N1B	00M14AJ251010	00M14AJ251010	BADGE	MZ BADGE GL
	003B	/N1S	00M14AJ251020	00M14AJ251020	BADGE	MZ BADGE SL
	005B	/N1B	00M28AK251010	00M28AK251010	BADGE	BADGE SACD GL SA7001
	005B	/N1S	00M28AK251020	00M28AK251020	BADGE	BADGE SACD SL SA7001
	008B	/N1B	00M356K251010	00M356K251010	BADGE	BADGE KI GL
	008B	/N1S	00M356K251030	00M356K251030	BADGE	BADGE KI SL
	010B	/N1B	00M28AK105020	00M28AK105020	CHASSIS	CHASSIS FRONT MOLD BL
	010B	/N1S	00M28AK105220	00M28AK105220	CHASSIS	CHASSIS FRONT MOLD SL
	025B		00M21AK158010	00M21AK158010	WINDOW	WINDOW
	030B	/N1B	00M28AK063020	00M28AK063020	ESCUTCHEON	ESCUTCHEON (R) BL
	030B	/N1S	00M28AK063220	00M28AK063220	ESCUTCHEON	ESCUTCHEON (R) SL
	040B		00M28AK355010	00M28AK355010	LENS	LENS DISPLAY OFF
	050B	/N1B	00M28AK270010	00M28AK270010	BUTTON	BUTTON FUNCTION BL
	050B	/N1S	00M28AK270210	00M28AK270210	BUTTON	BUTTON FUNCTION SL
	060B	/N1B	00M28AK270030	00M28AK270030	BUTTON	BUTTON SKIP BL SA7001
	060B	/N1S	00M28AK270230	00M28AK270230	BUTTON	BUTTON SKIP SL SA7001
	110B		00M376K121010	00M376K121010	LINK	LINK POWER
	111B		00M28AK112010	00M28AK112010	SHAFT	SHAFT POWER
	112B	/N1B	00M05AK270010	00M05AK270010	BUTTON	BUTTON POWER BL
	112B	/N1S	00M05AK270210	00M05AK270210	BUTTON	BUTTON POWER SL
	130B		00M28AK259020	00M28AK259020	BUSHING	BUSH ESCUTCHEON TRAY
	135B	/N1B	00M28AK063010	00M28AK063010	ESCUTCHEON	ESCUTCHEON TRAY BL
	135B	/N1S	00M28AK063210	00M28AK063210	ESCUTCHEON	ESCUTCHEON TRAY SL
	005G	/N1B	00M14AJ057110	00M14AJ057110	LEG	LEG GL (W/O RUBBER)
	005G	/N1S	00M14AJ057210	00M14AJ057210	LEG	LEG SL (W/O RUBBER)
	006G		00M14AJ056110	00M14AJ056110	BUFFER	RUBBER CUSHION FOR LEG
	093G	/N1B	00M284T154310	00M284T154310	KNOB	KNOB HEAD PHONE BL
	093G	/N1S	00M284T154350	00M284T154350	KNOB	KNOB HEAD PHONE SL
	014M		00M21AK304020	00M21AK304020	MECHANISM	MECHA LOADER AND MECHA TRAVERSE
	▲ J001		0410500010090	0410500010090	TERMINAL	! MC991874 AC INLET
	J607		646010012000S	646010012000S	TERMINAL	EW-2560T-LH-W(WHITE)
	J608		646010011007S	646010011007S	TERMINAL	EW-2560T-LH-R(RED)
	▲ L001		1010100090068	1010100090068	TRANSF.	# POWER TRANSFORMER 230V FOR SA7001KI
	L003		117010005009S	117010005009S	FERRITE CORE	TFCK-23-11-14
	L011		1170100010070	1170100010070	FERRITE CORE	FERRITE CORE TFCK-16813
	L012		119010002006S	119010002006S	COIL	HF70SH28X2X10
	PH16		nsp	nsp	PWB ASSY	POWER SW PWB(EXCLUDING F)ASSY
	PP16		nsp	nsp	PWB ASSY	PS,DAC,AUDIO PWB(SA7001KI.)ASSY
	PR16	/N1B	nsp	nsp	PWB ASSY	HEADPHONE PWB(GOLD JACK)ASSY
	PR16	/N1S	nsp	nsp	PWB ASSY	HEADPHONE PWB(SILVER JACK)ASSY
	PY16		nsp	nsp	PWB ASSY	FRONT PWB(SA7001/KI)ASSY
	WF04		nsp	606050002003S	FPC	SMCD-25X120-BDX6-P1.0-S4-M UL2896
	WF05		nsp	606050002003S	FPC	SMCD-25X120-BDX6-P1.0-S4-M UL2896
	WF07		nsp	606050001000S	FPC	SMCD-17X120-BDX8(BL)-P1.0-S4M UL2896
PACKING						
	005T		00M28AK851310	00M28AK851310	USER GUIDE	USER GUDIE SA7001 (N)
	T100		3070100030048	3070100030048	UNIT KIT	REMOTE CONTROLLER RC7001SA
	▲ W001		0110500020010	0110500020010	MAINS CORD	# 970304/1 EUROPEAN MAINS CORDT
NOT STANDARD SPARE PART						
	005S		nsp	00M28AK809010	CUSHION	CUSHION(L R) SA7001
	010S		nsp	00M28AK801010	PACKING CASE	PACKING CASE SA7001
	101D	/N1B	nsp	00M14AJ257020	LID	TOP COVER BL SLIT LESS
	101D	/N1S	nsp	00M14AJ257220	LID	TOP COVER SL SLIT LESS
	J051		nsp	605010002002S	CONN. CORD	TWIN SHIELDED WIRE WITH RCA PLUGS
	J082		nsp	605010003005S	CONN. CORD	030320/1 (HK03-017-03)

NOTE : "nsp" PART IS LISTED FOR REFERENCE ONLY, MARANTZ WILL NOT SUPPLY THESE PARTS.

12. ELECTRICAL PARTS LIST

PARTS INFORMATION

RESISTORS

- 1) 00MGD05×××140, Carbon film fixed resistor, ±5% 1/4W
 2) 00MGD05×××160, Carbon film fixed resistor, ±5% 1/6W

① — Resistance value

Examples ;

① Resistance value

0.1 Ω 001	10 Ω 100	1 kΩ 102	100 kΩ 104
0.5 Ω 005	18 Ω 180	2.7 kΩ 272	680 kΩ 684
1 Ω 010	100 Ω 101	10 kΩ 103	1 MΩ 105
6.8 Ω 068	390 Ω 391	22 kΩ 223	4.7 MΩ 475

Note : Please distinguish 1/4W from 1/6W by the shape of parts used actually.

CAPACITORS

CERAMIC CAP.

- 3) 00MDD1××××370 Ceramic capacitor
 Disc type
 Temp.coeff.P350 ~N1000, 50V
- ② — Capacity value
 ③ — Tolerance

Examples ;

② Tolerance (Capacity deviation)

±0.25 pF 0	±0.5 pF 1	±5% 5
-----------------	----------------	------------

* Tolerance of COMMON PARTS handled here are as follows :

0.5 pF ~ 5 pF ±0.25 pF
6 pF ~ 10 pF ±0.5 pF
12 pF ~ 560 pF ±5%

③ Capacity value

0.5 pF 005	3 pF 030	100 pF 101
1 pF 010	10 pF 100	220 pF 221
1.5 pF 015	47 pF 470	560 pF 561

CERAMIC CAP.

- 4) 00MDK16×××300, High dielectric constant ceramic capacitor
 Disc type
 Temp.chara. 2B4, 50V
- ④ — Capacity value

Examples ;

④ Capacity value

100 pF 101	1000 pF 102	10000 pF 103
470 pF 471	2200 pF 222	

ELECTROLY CAP. ($\frac{\text{—}}{\text{—}}$)

- 5) 00MEA×××××10, Electrolytic capacitor
 One-way lead type, Tolerance ±20%
- ⑤ — Capacity value
 ⑥ — Working voltage

Examples ;

⑤ Capacity value

0.1 μF 104	4.7 μF 475	100 μF 107
0.33 μF 334	10 μF 106	330 μF 337
1 μF 105	22 μF 226	1100 μF 118
		2200 μF 228

⑥ Working voltage

6.3V 006	25V 025
10V 010	35V 035
16V 016	50V 050

FILM CAP. ($\frac{\text{—}}{\text{—}}$)

- 6) 00MDF15×××350 Plastic film capacitor
 One-way type, Mylar ±5% 50V
 00MDF15×××310 Plastic film capacitor
 One-way type, Mylar ±10% 50V
- ⑦ — Capacity value

Examples ;

⑦ Capacity value

0.001 μF (1000 pF) 102	0.1 μF 104
0.0018 μF 182	0.56 μF 564
0.01 μF 103	1 μF 105
0.015 μF 153	

NOTE ON SAFETY FOR FUSIBLE RESISTOR :

The suppliers and their type numbers of fusible resistors are as follows;

1. KOA Corporation

Part No. (MJI)	Type No. (KOA)	Description
00MNH05×××140	RF25S××××ΩJ	(±5% 1/4W)
00MNH05×××120	RF50S××××ΩJ	(±5% 1/2W)
00MNH85×××110	RF73B2A××××ΩJ	(±5% 1/10W)
00MNH95×××140	RF73B2E××××ΩJ	(±5% 1/4W)

* Resistance value (0.1 Ω – 10 kΩ)

2. Matsushita Electronic Components Co., Ltd

Part No. (MJI)	Type No. (MEC)	Description
00MNF05×××140	ERD-2FCJ×××	(±5% 1/4W)
00MRF05×××140		
00MNF02×××140	ERD-2FCG×××	(±2% 1/4W)
00MRF02×××140		

* Resistance value

Examples ;

* Resistance value

0.1 Ω 001	10 Ω 100	1 kΩ 102	100 kΩ 104
0.5 Ω 005	18 Ω 180	2.7 kΩ 272	680 kΩ 684
1 Ω 010	100 Ω 101	10 kΩ 103	1 MΩ 105
6.8 Ω 068	390 Ω 391	22 kΩ 223	4.7 MΩ 475



ABBREVIATION AND MARKS

ANT. : ANTENNA	BATT. : BATTERY
CAP. : CAPACITOR	CER. : CERAMIC
CONN. : CONNECTING	DIG. : DIGITAL
HP : HEADPHONE	MIC. : MICROPHONE
μ-PRO : MICROPROCESSOR	REC. : RECORDING
RES. : RESISTOR	SPK : SPEAKER
SW : SWITCH	TRANSF. : TRANSFORMER
TRIM. : TRIMMING	TRS. : TRANSISTOR
VAR. : VARIABLE	X'TAL : CRYSTAL

NOTE ON FUSE :

Regarding to all parts of parts code 00MFS20xxx2xx, replace only with Wickmann-Werke GmbH, Type 372 non glass type fuse.

NOTE ON SAFETY :

Symbol  Fire or electrical shock hazard. Only original parts should be used to replaced any part marked with symbol . Any other component substitution (other than original type), may increase risk of fire or electrical shock hazard.

安全上の注意 :

がついている部品は、安全上重要な部品です。必ず指定されている部品番号の部品を使用して下さい。

PWB NAME	POS. NO.	VERS. COLOR	PART NO. (FOR EUR)	PART NO. (MZ)	PART NAME	DESCRIPTION
					POWER SW PWB PH16 (632010008002M)	
PH16	▲ FH01		652050003405S	652050003405S	FUSE	! C1 372/1.25A
PH16	▲ GH01		1330500010070	1330500010070	FILM CAP.	! CF-MH22E103M-C
PH16	RH02		nsp	00D2472005903	CHIP RES.	RM73B--101JT +1608
PH16	▲ SH01		661050003003S	661050003003S	SW	! ESB92S94B
					POWER SUPPLY,DAC,AUDIO PWB PP16 (632010003007M)	
PP16	C601		133050048402S	133050048402S	FILM CAP.	DTG-100VDC-182J-TP
PP16	C602		1330500434070	1330500434070	FILM CAP.	DTG-100VDC-331J-TP
PP16	C604		133050045403S	133050045403S	FILM CAP.	DAMG-630VDC-121J-TP
PP16	C605		134050026405S	134050026405S	ELECT. CAP.	ROA-16V221MH4#-T2
PP16	C606		134050026405S	134050026405S	ELECT. CAP.	ROA-16V221MH4#-T2
PP16	C609		133050047409S	133050047409S	FILM CAP.	DTG-100VDC-122J-TP
PP16	C610		133050046406S	133050046406S	FILM CAP.	DTG-100VDC-561J-TP
PP16	C612		1330500444000	1330500444000	FILM CAP.	DTG-100VDC-681J-TP
PP16	C613		134050026405S	134050026405S	ELECT. CAP.	ROA-16V221MH4#-T2
PP16	C614		134050026405S	134050026405S	ELECT. CAP.	ROA-16V221MH4#-T2
PP16	C616		134050028401S	134050028401S	ELECT. CAP.	ROS-16V221MH5#PE-T2
PP16	C617		134050028401S	134050028401S	ELECT. CAP.	ROS-16V221MH5#PE-T2
PP16	C651		133050048402S	133050048402S	FILM CAP.	DTG-100VDC-182J-TP
PP16	C652		1330500434070	1330500434070	FILM CAP.	DTG-100VDC-331J-TP
PP16	C654		133050045403S	133050045403S	FILM CAP.	DAMG-630VDC-121J-TP
PP16	C659		133050047409S	133050047409S	FILM CAP.	DTG-100VDC-122J-TP
PP16	C660		133050046406S	133050046406S	FILM CAP.	DTG-100VDC-561J-TP
PP16	C662		1330500444000	1330500444000	FILM CAP.	DTG-100VDC-681J-TP
PP16	C666		134050028401S	134050028401S	ELECT. CAP.	ROS-16V221MH5#PE-T2
PP16	C667		134050028401S	134050028401S	ELECT. CAP.	ROS-16V221MH5#PE-T2
PP16	▲ C801		134010166008S	134010166008S	ELECT. CAP.	! RA2-16V682MK8#8-S1
PP16	C802		1340100245000	1340100245000	ELECT. CAP.	RA2-10V102MH4#8-T2
PP16	▲ C804		134010163009S	134010163009S	ELECT. CAP.	! RA2-16V332MJ6#8-S1
PP16	▲ C805		134010166008S	134010166008S	ELECT. CAP.	! RA2-16V682MK8#8-S1
PP16	C806		1340100245000	1340100245000	ELECT. CAP.	RA2-10V102MH4#8-T2
PP16	C809		1340100245000	1340100245000	ELECT. CAP.	RA2-10V102MH4#8-T2
PP16	▲ C821		134010165005S	134010165005S	ELECT. CAP.	! RA2-25V472MK8#8-S1
PP16	C822		1340100465000	1340100465000	ELECT. CAP.	RA2-25V221MG3#8-T2
PP16	C823		134010162006S	134010162006S	ELECT. CAP.	RA2-16V222M16#8-S1
PP16	▲ C851		134050031001S	134050031001S	ELECT. CAP.	! 3300U 25V (ALP) (LF)-BLOCK CAP
PP16	▲ C852		134050031001S	134050031001S	ELECT. CAP.	! 3300U 25V (ALP) (LF)-BLOCK CAP
PP16	C855		134050027408S	134050027408S	ELECT. CAP.	ROA-25V100ME3#-T2
PP16	C856		134050027408S	134050027408S	ELECT. CAP.	ROA-25V100ME3#-T2
PP16	C857		134050029008S	134050029008S	ELECT. CAP.	ROS-16V471M16#PE-S13
PP16	C858		134050029008S	134050029008S	ELECT. CAP.	ROS-16V471M16#PE-S13
PP16	CD21		1340100705030	1340100705030	ELECT. CAP.	RA2-50V100ME3E#8-T2
PP16	CD22		1340100455070	1340100455070	ELECT. CAP.	RA2-25V101MF3#8-T2
PP16	CD26		1340100465000	1340100465000	ELECT. CAP.	RA2-25V221MG3#8-T2
PP16	CD61		1340100455070	1340100455070	ELECT. CAP.	RA2-25V101MF3#8-T2
PP16	CD64		1340100455070	1340100455070	ELECT. CAP.	RA2-25V101MF3#8-T2
PP16	CD65		134050027408S	134050027408S	ELECT. CAP.	ROA-25V100ME3#-T2
PP16	CD67		134050025402S	134050025402S	ELECT. CAP.	ROA-10V101MG3#-T2
PP16	CD70		1330100135070	1330100135070	FILM CAP.	APSV 0100 J 102 0000 0200
PP16	CF52		1330100095080	1330100095080	FILM CAP.	APSV 0100 J 471 0000 0200
PP16	CF54		1340100705030	1340100705030	ELECT. CAP.	RA2-50V100ME3E#8-T2
PP16	CN01		134010161003S	134010161003S	ELECT. CAP.	RA2-25V102MI5#8-S1
PP16	CN02		1340100665040	1340100665040	ELECT. CAP.	RA2-50V010ME3E#8-T2
PP16	CN03		1340100695030	1340100695030	ELECT. CAP.	RA2-50V4R7ME3E#8-T2
PP16	CN04		133050049405S	133050049405S	FILM CAP.	MTFVA0050J10400000200
PP16	CT05		134050030404S	134050030404S	ELECT. CAP.	ROS-25V101MH4#PE-T2
PP16	▲ CY51		1340100755080	1340100755080	ELECT. CAP.	! RA2-50V221MH4#8-T2
PP16	▲ CY52		1340100755080	1340100755080	ELECT. CAP.	! RA2-50V221MH4#8-T2
PP16	CY63		1340100745050	1340100745050	ELECT. CAP.	RA2-50V101MG3#8-T2
PP16	D601		nsp	00D2760401905	DIODE	1SS133T77
PP16	D602		nsp	00D2760401905	DIODE	1SS133T77
PP16	D603		nsp	00D2760401905	DIODE	1SS133T77
PP16	D604		nsp	00D2760401905	DIODE	1SS133T77
PP16	D605		nsp	00D2760401905	DIODE	1SS133T77
PP16	D606		nsp	00D2760401905	DIODE	1SS133T77
PP16	D607		nsp	00D2760401905	DIODE	1SS133T77
PP16	D608		nsp	00D2760401905	DIODE	1SS133T77

NOTE : "nsp" PART IS LISTED FOR REFERENCE ONLY, MARANTZ WILL NOT SUPPLY THESE PARTS.

PWB NAME	POS. NO.	VERS. COLOR	PART NO. (FOR EUR)	PART NO. (MZ)	PART NAME	DESCRIPTION
PP16	D609		nsp	00D2760401905	DIODE	1SS133T77
PP16	D610		nsp	00D2760401905	DIODE	1SS133T77
PP16	D611		nsp	00D2760401905	DIODE	1SS133T77
PP16	D612		nsp	00D2760401905	DIODE	1SS133T77
PP16	D613		nsp	00D2760401905	DIODE	1SS133T77
PP16	D651		nsp	00D2760401905	DIODE	1SS133T77
PP16	D652		nsp	00D2760401905	DIODE	1SS133T77
PP16	D653		nsp	00D2760401905	DIODE	1SS133T77
PP16	D654		nsp	00D2760401905	DIODE	1SS133T77
PP16	D655		nsp	00D2760401905	DIODE	1SS133T77
PP16	D656		nsp	00D2760401905	DIODE	1SS133T77
PP16	D657		nsp	00D2760401905	DIODE	1SS133T77
PP16	D658		nsp	00D2760401905	DIODE	1SS133T77
PP16	D659		nsp	00D2760401905	DIODE	1SS133T77
PP16	D660		nsp	00D2760401905	DIODE	1SS133T77
PP16	D661		nsp	00D2760401905	DIODE	1SS133T77
PP16	D662		nsp	00D2760401905	DIODE	1SS133T77
PP16	D663		nsp	00D2760401905	DIODE	1SS133T77
PP16	▲ D801		2040500013050	2040500013050	DIODE	! SHOTTKY 11EQS10 1A 100V
PP16	▲ D802		2040500013050	2040500013050	DIODE	! SHOTTKY 11EQS10 1A 100V
PP16	▲ D803		2040500013050	2040500013050	DIODE	! SHOTTKY 11EQS10 1A 100V
PP16	▲ D804		2040500013050	2040500013050	DIODE	! SHOTTKY 11EQS10 1A 100V
PP16	▲ D805		2030500013020	2030500013020	DIODE	! 1D3 1A/200V
PP16	▲ D806		2030500013020	2030500013020	DIODE	! 1D3 1A/200V
PP16	▲ D807		2030500013020	2030500013020	DIODE	! 1D3 1A/200V
PP16	▲ D808		2030500013020	2030500013020	DIODE	! 1D3 1A/200V
PP16	▲ D809		2030500013020	2030500013020	DIODE	! 1D3 1A/200V
PP16	▲ D821		2030500013020	2030500013020	DIODE	! 1D3 1A/200V
PP16	▲ D822		2030500013020	2030500013020	DIODE	! 1D3 1A/200V
PP16	▲ D851		2030500013020	2030500013020	DIODE	! 1D3 1A/200V
PP16	▲ D852		2030500013020	2030500013020	DIODE	! 1D3 1A/200V
PP16	▲ D853		2030500013020	2030500013020	DIODE	! 1D3 1A/200V
PP16	▲ D854		2030500013020	2030500013020	DIODE	! 1D3 1A/200V
PP16	D856		nsp	00D2760407912	DIODE	HZ6A-1LTD
PP16	D857		nsp	00D2760407912	DIODE	HZ6A-1LTD
PP16	D858		nsp	00D2760401905	DIODE	1SS133T77
PP16	D859		nsp	00D2760401905	DIODE	1SS133T77
PP16	DF51		nsp	00D2760401905	DIODE	1SS133T77
PP16	▲ DN01		2030500013020	2030500013020	DIODE	! 1D3 1A/200V
PP16	▲ DN02		2030500013020	2030500013020	DIODE	! 1D3 1A/200V
PP16	DN05		2030500013020	2030500013020	DIODE	1D3 1A/200V
PP16	DN06		nsp	00D2760647918	DIODE	MTZJ47 T77
PP16	DN07		nsp	00D2760401905	DIODE	1SS133T77
PP16	DN11		nsp	00D2760401905	DIODE	1SS133T77
PP16	DN12		nsp	00D2760401905	DIODE	1SS133T77
PP16	DY11		nsp	00D2760647918	DIODE	MTZJ47 T77
PP16	▲ DY51		2030500013020	2030500013020	DIODE	! 1D3 1A/200V
PP16	▲ DY52		2030500013020	2030500013020	DIODE	! 1D3 1A/200V
PP16	DY61		203050002305S	203050002305S	DIODE	MTZ J27D
PP16	DY65		203050002305S	203050002305S	DIODE	MTZ J27D
PP16	▲ F801		652050003405S	652050003405S	FUSE	! C1 372/1.25A
PP16	▲ F821		652050002402S	652050002402S	FUSE	! C1 372/1A
PP16	▲ F822		652050002402S	652050002402S	FUSE	! C1 372/1A
PP16	▲ F851		652050001409S	652050001409S	FUSE	! C1 372/0.8A
PP16	▲ F852		652050001409S	652050001409S	FUSE	! C1 372/0.8A
PP16	JF51		0460100040050	0460100040050	TERMINAL	YKC21-3046
PP16	JT02		646010015009S	646010015009S	TERMINAL	YKC21-3394:1L1 FG AU ID
PP16	JT03		643010006006S	643010006006S	OPT. CONN.	TOTX179L TOSLINK TRANSCEIVER
PP16	L801		1190100014090	1190100014090	COIL	BL02RN2R1N1A FERRITE BEAD
PP16	L802		1190100014090	1190100014090	COIL	BL02RN2R1N1A FERRITE BEAD
PP16	L803		1190100014090	1190100014090	COIL	BL02RN2R1N1A FERRITE BEAD
PP16	LD01		1190100014090	1190100014090	COIL	BL02RN2R1N1A FERRITE BEAD
PP16	LT01		104010001001S	104010001001S	TRANSF.	TPS247MN-0386AN PULSE TRNSF.
PP16	LT02		1190100014090	1190100014090	COIL	BL02RN2R1N1A FERRITE BEAD
PP16	Q601		222010001404S	222010001404S	FET	2SK369 BL VGDS-40V PD0.4W
PP16	Q602		222010001404S	222010001404S	FET	2SK369 BL VGDS-40V PD0.4W
PP16	Q603		213050005400S	213050005400S	TRS.	2SC2240N-GR_BL(932202943676)

NOTE : "nsp" PART IS LISTED FOR REFERENCE ONLY, MARANTZ WILL NOT SUPPLY THESE PARTS.

PWB NAME	POS. NO.	VERS. COLOR	PART NO. (FOR EUR)	PART NO. (MZ)	PART NAME	DESCRIPTION
PP16	Q604		211050004401S	211050004401S	TRS.	2SA970 (GR) OR (BL)
PP16	Q605		211050004401S	211050004401S	TRS.	2SA970 (GR) OR (BL)
PP16	Q606		213050005400S	213050005400S	TRS.	2SC2240N-GR_BL(932202943676)
PP16	Q607		222050001402S	222050001402S	FET	2SK170-V (TPE2)
PP16	Q608		221050001409S	221050001409S	FET	2SJ74-V (TPE2)
PP16	Q609		222010001404S	222010001404S	FET	2SK369 BL VGDS-40V PDO.4W
PP16	Q610		222010001404S	222010001404S	FET	2SK369 BL VGDS-40V PDO.4W
PP16	Q611		213050005400S	213050005400S	TRS.	2SC2240N-GR_BL(932202943676)
PP16	Q612		211050004401S	211050004401S	TRS.	2SA970 (GR) OR (BL)
PP16	Q613		211050004401S	211050004401S	TRS.	2SA970 (GR) OR (BL)
PP16	Q614		213050005400S	213050005400S	TRS.	2SC2240N-GR_BL(932202943676)
PP16	Q615		222050001402S	222050001402S	FET	2SK170-V (TPE2)
PP16	Q616		221050001409S	221050001409S	FET	2SJ74-V (TPE2)
PP16	Q617		211050004401S	211050004401S	TRS.	2SA970 (GR) OR (BL)
PP16	Q618		211050004401S	211050004401S	TRS.	2SA970 (GR) OR (BL)
PP16	Q619		211050004401S	211050004401S	TRS.	2SA970 (GR) OR (BL)
PP16	Q620		213050005400S	213050005400S	TRS.	2SC2240N-GR_BL(932202943676)
PP16	Q621		213050005400S	213050005400S	TRS.	2SC2240N-GR_BL(932202943676)
PP16	Q622		213050005400S	213050005400S	TRS.	2SC2240N-GR_BL(932202943676)
PP16	Q623		213050005400S	213050005400S	TRS.	2SC2240N-GR_BL(932202943676)
PP16	Q624		211050004401S	211050004401S	TRS.	2SA970 (GR) OR (BL)
PP16	Q651		222010001404S	222010001404S	FET	2SK369 BL VGDS-40V PDO.4W
PP16	Q652		222010001404S	222010001404S	FET	2SK369 BL VGDS-40V PDO.4W
PP16	Q653		213050005400S	213050005400S	TRS.	2SC2240N-GR_BL(932202943676)
PP16	Q654		211050004401S	211050004401S	TRS.	2SA970 (GR) OR (BL)
PP16	Q655		211050004401S	211050004401S	TRS.	2SA970 (GR) OR (BL)
PP16	Q656		213050005400S	213050005400S	TRS.	2SC2240N-GR_BL(932202943676)
PP16	Q657		222050001402S	222050001402S	FET	2SK170-V (TPE2)
PP16	Q658		221050001409S	221050001409S	FET	2SJ74-V (TPE2)
PP16	Q659		222010001404S	222010001404S	FET	2SK369 BL VGDS-40V PDO.4W
PP16	Q660		222010001404S	222010001404S	FET	2SK369 BL VGDS-40V PDO.4W
PP16	Q661		213050005400S	213050005400S	TRS.	2SC2240N-GR_BL(932202943676)
PP16	Q662		211050004401S	211050004401S	TRS.	2SA970 (GR) OR (BL)
PP16	Q663		211050004401S	211050004401S	TRS.	2SA970 (GR) OR (BL)
PP16	Q664		213050005400S	213050005400S	TRS.	2SC2240N-GR_BL(932202943676)
PP16	Q665		222050001402S	222050001402S	FET	2SK170-V (TPE2)
PP16	Q666		221050001409S	221050001409S	FET	2SJ74-V (TPE2)
PP16	Q667		211050004401S	211050004401S	TRS.	2SA970 (GR) OR (BL)
PP16	Q668		211050004401S	211050004401S	TRS.	2SA970 (GR) OR (BL)
PP16	Q669		211050004401S	211050004401S	TRS.	2SA970 (GR) OR (BL)
PP16	Q670		213050005400S	213050005400S	TRS.	2SC2240N-GR_BL(932202943676)
PP16	Q671		213050005400S	213050005400S	TRS.	2SC2240N-GR_BL(932202943676)
PP16	Q672		213050005400S	213050005400S	TRS.	2SC2240N-GR_BL(932202943676)
PP16	Q673		213050005400S	213050005400S	TRS.	2SC2240N-GR_BL(932202943676)
PP16	Q674		211050004401S	211050004401S	TRS.	2SA970 (GR) OR (BL)
PP16	▲ Q801		00D2631092003	00D2631092003	IC	! BA05T
PP16	▲ Q802		00D2631092003	00D2631092003	IC	! BA05T
PP16	▲ Q803		00D2631092003	00D2631092003	IC	! BA05T
PP16	▲ Q821		231010003701S	231010003701S	IC	! BA12T
PP16	▲ Q822		231010004704S	231010004704S	IC	! NJM7808FA-#ZZS
PP16	Q851		222050002405S	222050002405S	FET	2SK246-GR
PP16	▲ Q852		2140500010050	2140500010050	TRS.	! 2SD1415A
PP16	Q853		213050005400S	213050005400S	TRS.	2SC2240N-GR_BL(932202943676)
PP16	Q855		222050002405S	222050002405S	FET	2SK246-GR
PP16	Q856		2120500010090	2120500010090	TRS.	2SB1020A
PP16	Q857		211050004401S	211050004401S	TRS.	2SA970 (GR) OR (BL)
PP16	▲ QD01		00D2631048002	00D2631048002	IC	! BA033T
PP16	QD21		00D2690223907	00D2690223907	TRS.	KRC111S-RTK +2125
PP16	QD22		00D2690223907	00D2690223907	TRS.	KRC111S-RTK +2125
PP16	QD23		211050004401S	211050004401S	TRS.	2SA970 (GR) OR (BL)
PP16	QD24		00D2730253918	00D2730253918	TRS.	2SC2878(A/B)TPE2
PP16	QD61		235010005501S	235010005501S	IC	CS4397-KSZR
PP16	QF51		2110500010060	2110500010060	TRS.	KTA1267 RANK=Y
PP16	QF52		2130500010020	2130500010020	TRS.	KTC3199 RANK=Y
PP16	QN01		2130500010020	2130500010020	TRS.	KTC3199 RANK=Y
PP16	QN02		00D2690223907	00D2690223907	TRS.	KRC111S-RTK +2125
PP16	QN04		2110500010060	2110500010060	TRS.	KTA1267 RANK=Y

NOTE : *nsp* PART IS LISTED FOR REFERENCE ONLY, MARANTZ WILL NOT SUPPLY THESE PARTS.

PWB NAME	POS. NO.	VERS. COLOR	PART NO. (FOR EUR)	PART NO. (MZ)	PART NAME	DESCRIPTION
PP16	QN06		2130500010020	2130500010020	TRS.	KTC3199 RANK=Y
PP16	QN61		00D2730253918	00D2730253918	TRS.	2SC2878(A/B)TPE2
PP16	QN62		00D2730253918	00D2730253918	TRS.	2SC2878(A/B)TPE2
PP16	QN63		00D2730253918	00D2730253918	TRS.	2SC2878(A/B)TPE2
PP16	QN64		00D2730253918	00D2730253918	TRS.	2SC2878(A/B)TPE2
PP16	QN66		00D2690223907	00D2690223907	TRS.	KRC111S-RTK +2125
PP16	QT01		234010002004S	234010002004S	IC	MC74HCU04AN
PP16	QY61		2110500010060	2110500010060	TRS.	KTA1267 RANK=Y
PP16	QY62		2130500010020	2130500010020	TRS.	KTC3199 RANK=Y
PP16	QY63		00D2690223907	00D2690223907	TRS.	KRC111S-RTK +2125
PP16	R103		nsp	00D2412396928	RES.	RD14B2E101JT(5)
PP16	R352		nsp	00D2412396928	RES.	RD14B2E101JT(5)
PP16	R601		nsp	00D2412398971	RES.	RD14B2E122JT(5)
PP16	R602		nsp	00D2412398971	RES.	RD14B2E122JT(5)
PP16	R603		nsp	00D2412397998	RES.	RD14B2E561JT(5)
PP16	R604		nsp	00D2412399912	RES.	RD14B2E182JT(5)
PP16	R605		nsp	00D2412399996	RES.	RD14B2E392JT(5)
PP16	R606		nsp	00D2412396944	RES.	RD14B2E121JT(5)
PP16	R607		nsp	00D2412396944	RES.	RD14B2E121JT(5)
PP16	R608		nsp	00D2412395987	RES.	RD14B2E680JT(5)
PP16	R609		nsp	00D2412397998	RES.	RD14B2E561JT(5)
PP16	R610		nsp	00D2412402919	RES.	RD14B2E333JT(5)
PP16	R611		nsp	00D2412396928	RES.	RD14B2E101JT(5)
PP16	R612		nsp	00D2412397998	RES.	RD14B2E561JT(5)
PP16	R613		nsp	00D2412395903	RES.	RD14B2E330JT(5)
PP16	R614		nsp	00D2412395903	RES.	RD14B2E330JT(5)
PP16	R615		nsp	00D2412400924	RES.	RD14B2E512JT(5)
PP16	R622		nsp	00D2412399938	RES.	RD14B2E222JT(5)
PP16	R623		nsp	00D2412399970	RES.	RD14B2E332JT(5)
PP16	R624		nsp	00D2412396944	RES.	RD14B2E121JT(5)
PP16	R625		nsp	00D2412396944	RES.	RD14B2E121JT(5)
PP16	R626		nsp	00D2412395987	RES.	RD14B2E680JT(5)
PP16	R627		nsp	00D2412397927	RES.	RD14B2E271JT(5)
PP16	R628		nsp	00D2412397998	RES.	RD14B2E561JT(5)
PP16	R629		nsp	00D2412402919	RES.	RD14B2E333JT(5)
PP16	R630		nsp	00D2412395945	RES.	RD14B2E470JT(5)
PP16	R631		nsp	00D2412397998	RES.	RD14B2E561JT(5)
PP16	R632		nsp	00D2412396928	RES.	RD14B2E101JT(5)
PP16	R633		nsp	00D2412396928	RES.	RD14B2E101JT(5)
PP16	R634		nsp	00D2412397927	RES.	RD14B2E271JT(5)
PP16	R635		nsp	00D2412397927	RES.	RD14B2E271JT(5)
PP16	R636		nsp	00D2412397927	RES.	RD14B2E271JT(5)
PP16	R637		nsp	00D2412397927	RES.	RD14B2E271JT(5)
PP16	R638		nsp	00D2412395945	RES.	RD14B2E470JT(5)
PP16	R639		nsp	00D2412395903	RES.	RD14B2E330JT(5)
PP16	R640		nsp	00D2412395903	RES.	RD14B2E330JT(5)
PP16	R641		nsp	00D2412396944	RES.	RD14B2E121JT(5)
PP16	R643		nsp	00D2412402951	RES.	RD14B2E473JT(5)
PP16	R644		nsp	00D2412395990	RES.	RD14B2E750JT(5)
PP16	R645		nsp	00D2412395990	RES.	RD14B2E750JT(5)
PP16	R647		nsp	00D2412396928	RES.	RD14B2E101JT(5)
PP16	R651		nsp	00D2412398971	RES.	RD14B2E122JT(5)
PP16	R652		nsp	00D2412398971	RES.	RD14B2E122JT(5)
PP16	R653		nsp	00D2412397998	RES.	RD14B2E561JT(5)
PP16	R654		nsp	00D2412399912	RES.	RD14B2E182JT(5)
PP16	R655		nsp	00D2412399996	RES.	RD14B2E392JT(5)
PP16	R656		nsp	00D2412396944	RES.	RD14B2E121JT(5)
PP16	R657		nsp	00D2412396944	RES.	RD14B2E121JT(5)
PP16	R658		nsp	00D2412395987	RES.	RD14B2E680JT(5)
PP16	R659		nsp	00D2412397998	RES.	RD14B2E561JT(5)
PP16	R660		nsp	00D2412402919	RES.	RD14B2E333JT(5)
PP16	R661		nsp	00D2412396928	RES.	RD14B2E101JT(5)
PP16	R662		nsp	00D2412397998	RES.	RD14B2E561JT(5)
PP16	R663		nsp	00D2412395903	RES.	RD14B2E330JT(5)
PP16	R664		nsp	00D2412395903	RES.	RD14B2E330JT(5)
PP16	R665		nsp	00D2412400924	RES.	RD14B2E512JT(5)
PP16	R672		nsp	00D2412399938	RES.	RD14B2E222JT(5)

NOTE : "nsp" PART IS LISTED FOR REFERENCE ONLY, MARANTZ WILL NOT SUPPLY THESE PARTS.

PWB NAME	POS. NO.	VERS. COLOR	PART NO. (FOR EUR)	PART NO. (MZ)	PART NAME	DESCRIPTION
PP16	R673		nsp	00D2412399970	RES.	RD14B2E332JT(5)
PP16	R674		nsp	00D2412396944	RES.	RD14B2E121JT(5)
PP16	R675		nsp	00D2412396944	RES.	RD14B2E121JT(5)
PP16	R676		nsp	00D2412395987	RES.	RD14B2E680JT(5)
PP16	R677		nsp	00D2412397927	RES.	RD14B2E271JT(5)
PP16	R678		nsp	00D2412397998	RES.	RD14B2E561JT(5)
PP16	R679		nsp	00D2412402919	RES.	RD14B2E333JT(5)
PP16	R680		nsp	00D2412395945	RES.	RD14B2E470JT(5)
PP16	R681		nsp	00D2412397998	RES.	RD14B2E561JT(5)
PP16	R682		nsp	00D2412396928	RES.	RD14B2E101JT(5)
PP16	R683		nsp	00D2412396928	RES.	RD14B2E101JT(5)
PP16	R684		nsp	00D2412397927	RES.	RD14B2E271JT(5)
PP16	R685		nsp	00D2412397927	RES.	RD14B2E271JT(5)
PP16	R686		nsp	00D2412397927	RES.	RD14B2E271JT(5)
PP16	R687		nsp	00D2412397927	RES.	RD14B2E271JT(5)
PP16	R688		nsp	00D2412395945	RES.	RD14B2E470JT(5)
PP16	R689		nsp	00D2412395903	RES.	RD14B2E330JT(5)
PP16	R690		nsp	00D2412395903	RES.	RD14B2E330JT(5)
PP16	R691		nsp	00D2412396944	RES.	RD14B2E121JT(5)
PP16	R693		nsp	00D2412402951	RES.	RD14B2E473JT(5)
PP16	R694		nsp	00D2412395990	RES.	RD14B2E750JT(5)
PP16	R695		nsp	00D2412395990	RES.	RD14B2E750JT(5)
PP16	R697		nsp	00D2412396928	RES.	RD14B2E101JT(5)
PP16	R851		nsp	00D2412396928	RES.	RD14B2E101JT(5)
PP16	R852		nsp	00D2412396928	RES.	RD14B2E101JT(5)
PP16	R853		nsp	00D2412399954	RES.	RD14B2E272JT(5)
PP16	R854		nsp	00D2412399970	RES.	RD14B2E332JT(5)
PP16	R855		nsp	00D2412399954	RES.	RD14B2E272JT(5)
PP16	R856		nsp	00D2412399970	RES.	RD14B2E332JT(5)
PP16	R857		nsp	00D2412399970	RES.	RD14B2E332JT(5)
PP16	R858		nsp	00D2412399970	RES.	RD14B2E332JT(5)
PP16	RD22		nsp	00D2412400911	RES.	RD14B2E472JT(5)
PP16	RD23		nsp	00D2412398971	RES.	RD14B2E122JT(5)
PP16	RD24		nsp	00D2412398997	RES.	RD14B2E152JT(5)
PP16	RD25		nsp	00D2412399996	RES.	RD14B2E392JT(5)
PP16	RD63		nsp	00D2412400995	RES.	RD14B2E103JT(5)
PP16	RD64		nsp	00D2412401952	RES.	RD14B2E183JT(5)
PP16	RD65		nsp	00D2412401952	RES.	RD14B2E183JT(5)
PP16	RF51		nsp	00D2412394962	RES.	RD14B2E220JT(5)
PP16	RF52		nsp	00D2412400911	RES.	RD14B2E472JT(5)
PP16	RF53		nsp	00D2412400911	RES.	RD14B2E472JT(5)
PP16	RF54		nsp	00D2412402951	RES.	RD14B2E473JT(5)
PP16	RF55		nsp	00D2412401952	RES.	RD14B2E183JT(5)
PP16	RF56		nsp	00D2412400911	RES.	RD14B2E472JT(5)
PP16	RF57		nsp	00D2412396928	RES.	RD14B2E101JT(5)
PP16	RF58		nsp	00D2412400979	RES.	RD14B2E822JT(5)
PP16	RN01		nsp	00D2412401936	RES.	RD14B2E153JT(5)
PP16	RN02		nsp	00D2412400995	RES.	RD14B2E103JT(5)
PP16	RN03		nsp	00D2412402951	RES.	RD14B2E473JT(5)
PP16	RN04		nsp	00D2412402951	RES.	RD14B2E473JT(5)
PP16	RN05		nsp	00D2412403934	RES.	RD14B2E104JT(5)
PP16	RN06		nsp	00D2412398971	RES.	RD14B2E122JT(5)
PP16	RN09		nsp	00D2412402951	RES.	RD14B2E473JT(5)
PP16	RN10		nsp	00D2412405990	RES.	RD14B2E225JT(5)
PP16	RN61		nsp	00D2412400911	RES.	RD14B2E472JT(5)
PP16	RN62		nsp	00D2412400911	RES.	RD14B2E472JT(5)
PP16	RN63		nsp	00D2412400911	RES.	RD14B2E472JT(5)
PP16	RN64		nsp	00D2412400911	RES.	RD14B2E472JT(5)
PP16	RT01		nsp	00D2412396928	RES.	RD14B2E101JT(5)
PP16	RT02		nsp	00D2412395903	RES.	RD14B2E330JT(5)
PP16	RT03		nsp	00D2412395990	RES.	RD14B2E750JT(5)
PP16	RT04		nsp	00D2412395903	RES.	RD14B2E330JT(5)
PP16	RT05		nsp	00D2412398971	RES.	RD14B2E122JT(5)
PP16	RT06		nsp	00D2412403934	RES.	RD14B2E104JT(5)
PP16	RY51		nsp	00D2412396928	RES.	RD14B2E101JT(5)
PP16	▲ RY55		129050002308S	129050002308S	RES.	! RF25S 10OHM J VTE
PP16	RY56		nsp	00D2412400911	RES.	RD14B2E472JT(5)

NOTE : "nsp" PART IS LISTED FOR REFERENCE ONLY, MARANTZ WILL NOT SUPPLY THESE PARTS.

PWB NAME	POS. NO.	VERS. COLOR	PART NO. (FOR EUR)	PART NO. (MZ)	PART NAME	DESCRIPTION
PP16	RY57		nsp	00D2412400995	RES.	RD14B2E103JT(5)
PP16	RY58		nsp	00D2412402951	RES.	RD14B2E473JT(5)
PP16	RY59		nsp	00D2412395945	RES.	RD14B2E470JT(5)
PP16	RY60		nsp	00D2412395945	RES.	RD14B2E470JT(5)
PP16	RY61		nsp	00D2412400911	RES.	RD14B2E472JT(5)
PP16	SF51		664010002001S	664010002001S	SW	SSSU120300
HEADPHONE PWB PR16 (632010005003M)						
PR16	C901		1340100445040	1340100445040	ELECT CAP.	RA2-25V470ME3#8-T2
PR16	C902		1340100445040	1340100445040	ELECT CAP.	RA2-25V470ME3#8-T2
PR16	C903		1340100465000	1340100465000	ELECT CAP.	RA2-25V221MG3#8-T2
PR16	C904		1340100465000	1340100465000	ELECT CAP.	RA2-25V221MG3#8-T2
PR16	C905		1340100445040	1340100445040	ELECT CAP.	RA2-25V470ME3#8-T2
PR16	C906		1340100445040	1340100445040	ELECT CAP.	RA2-25V470ME3#8-T2
PR16	D901		nsp	00D2760401905	DIODE	1SS133T77
PR16	D902		nsp	00D2760401905	DIODE	1SS133T77
PR16	D903		nsp	00D2760401905	DIODE	1SS133T77
PR16	D904		nsp	00D2760401905	DIODE	1SS133T77
PR16	J903	/N1B	6430100040000	6430100040000	TERMINAL	YKB26-5138 HP JACK(GOLD)
PR16	J903	/N1S	6430100050030	6430100050030	TERMINAL	YKB26-5009 HP JACK(SILVER)
PR16	L901		1190100014090	1190100014090	COIL	BL02RN2R1N1A FERRITE BEAD
PR16	L902		1190100014090	1190100014090	COIL	BL02RN2R1N1A FERRITE BEAD
PR16	Q901		00D2630118014	00D2630118014	IC	NJM4560DD
PR16	Q903		213050005400S	213050005400S	TRS.	2SC2240N-GR_BL(932202943676)
PR16	Q904		213050005400S	213050005400S	TRS.	2SC2240N-GR_BL(932202943676)
PR16	Q905		211050004401S	211050004401S	TRS.	2SA970 (GR) OR (BL)
PR16	Q906		211050004401S	211050004401S	TRS.	2SA970 (GR) OR (BL)
PR16	Q907		00D2730253918	00D2730253918	TRS.	2SC2878(A/B)TPE2
PR16	Q908		00D2730253918	00D2730253918	TRS.	2SC2878(A/B)TPE2
PR16	Q909		00D2730253918	00D2730253918	TRS.	2SC2878(A/B)TPE2
PR16	Q910		00D2730253918	00D2730253918	TRS.	2SC2878(A/B)TPE2
PR16	R901		nsp	00D2412396928	RES.	RD14B2E101JT(5)
PR16	R902		nsp	00D2412396928	RES.	RD14B2E101JT(5)
PR16	R903		nsp	00D2412395903	RES.	RD14B2E330JT(5)
PR16	R904		nsp	00D2412395903	RES.	RD14B2E330JT(5)
PR16	R905		nsp	00D2412395903	RES.	RD14B2E330JT(5)
PR16	R906		nsp	00D2412395903	RES.	RD14B2E330JT(5)
PR16	R907		nsp	00D2412398997	RES.	RD14B2E152JT(5)
PR16	R908		nsp	00D2412398997	RES.	RD14B2E152JT(5)
PR16	R909		nsp	00D2412398997	RES.	RD14B2E152JT(5)
PR16	R910		nsp	00D2412398997	RES.	RD14B2E152JT(5)
PR16	R911		nsp	00D2412395903	RES.	RD14B2E330JT(5)
PR16	R912		nsp	00D2412395903	RES.	RD14B2E330JT(5)
PR16	R913		nsp	00D2412395903	RES.	RD14B2E330JT(5)
PR16	R914		nsp	00D2412395903	RES.	RD14B2E330JT(5)
PR16	R915		nsp	00D2412403934	RES.	RD14B2E104JT(5)
PR16	R916		nsp	00D2412403934	RES.	RD14B2E104JT(5)
PR16	R917		nsp	00D2412396928	RES.	RD14B2E101JT(5)
PR16	R918		nsp	00D2412396928	RES.	RD14B2E101JT(5)
PR16	R919		nsp	00D2412400911	RES.	RD14B2E472JT(5)
PR16	R920		nsp	00D2412400911	RES.	RD14B2E472JT(5)
PR16	R921		nsp	00D2412400911	RES.	RD14B2E472JT(5)
PR16	R922		nsp	00D2412400911	RES.	RD14B2E472JT(5)
PR16	R923		nsp	00D2412400911	RES.	RD14B2E472JT(5)
PR16	R924		nsp	00D2412400911	RES.	RD14B2E472JT(5)
PR16	R925		nsp	00D2412400911	RES.	RD14B2E472JT(5)
PR16	R926		nsp	00D2412400911	RES.	RD14B2E472JT(5)
PR16	R930		679010001000S	679010001000S	VER. RES.	RK09L12B0
PR16	R951	/N1S	nsp	00D2412396928	RES.	RD14B2E101JT(5)
PR16	R952	/N1B	nsp	00D2412396928	RES.	RD14B2E101JT(5)
FRONT PWB PY16 (632010007009M)						
PY16	CY01		1340100445040	1340100445040	ELECT CAP.	RA2-25V470ME3#8-T2
PY16	CY02		nsp	00D2570512903	CER. CAP.	CK73F1E104ZT +1608
PY16	CY03		1340100445040	1340100445040	ELECT CAP.	RA2-25V470ME3#8-T2
PY16	CY04		nsp	00D2570511920	CER. CAP.	CK73F1H473ZT +1608
PY16	CY05		1340100215010	1340100215010	ELECT CAP.	RA2-10V221MF3#8-T2
PY16	CY06		nsp	00D2570512903	CER. CAP.	CK73F1E104ZT +1608
PY16	CY07		nsp	132050006504S	CER. CAP.	GRM188B11H331KA01D

NOTE : "nsp" PART IS LISTED FOR REFERENCE ONLY, MARANTZ WILL NOT SUPPLY THESE PARTS.

PWB NAME	POS. NO.	VERS. COLOR	PART NO. (FOR EUR)	PART NO. (MZ)	PART NAME	DESCRIPTION
PY16	CY08		nsp	00D2570512903	CER. CAP.	CK73F1E104ZT +1608
PY16	CY09		nsp	00D2570512903	CER. CAP.	CK73F1E104ZT +1608
PY16	DY02		2630100010090	2630100010090	L.E.D.	LT3D8B RED LED
PY16	DY07		202050001507S	202050001507S	ZENER DIODE	02CZ3.9-X(TE85L)
PY16	LY01		1190100014090	1190100014090	COIL	BL02RN2R1N1A FERRITE BEAD
PY16	LY02		1190100014090	1190100014090	COIL	BL02RN2R1N1A FERRITE BEAD
PY16	LY03		1190100014090	1190100014090	COIL	BL02RN2R1N1A FERRITE BEAD
PY16	LY04		1190100014090	1190100014090	COIL	BL02RN2R1N1A FERRITE BEAD
PY16	QY01		239010002009S	239010002009S	IC	ML9207-01GP
PY16	QY02		214050003506S	214050003506S	TRS.	2SC4081 (Q_R) (312000451210)
PY16	QY05		212050002507S	212050002507S	TRS.	2SA1586 (Y_GR) TE85L
PY16	RY01		nsp	00D2472006915	CHIP RES.	RM73B--271JT +1608
PY16	RY02		nsp	00D2472006915	CHIP RES.	RM73B--271JT +1608
PY16	RY03		nsp	00D2472006944	CHIP RES.	RM73B--391JT +1608
PY16	RY04		nsp	00D2472005961	CHIP RES.	RM73B--181JT +1608
PY16	RY05		nsp	00D2472005961	CHIP RES.	RM73B--181JT +1608
PY16	RY06		nsp	00D2472005945	CHIP RES.	RM73B--151JT +1608
PY16	RY09		nsp	00D2472006944	CHIP RES.	RM73B--391JT +1608
PY16	RY10		nsp	00D2472005945	CHIP RES.	RM73B--151JT +1608
PY16	RY13		nsp	00D2472007943	CHIP RES.	RM73B--102JT +1608
PY16	RY14		nsp	00D2472009983	CHIP RES.	RM73B--103JT +1608
PY16	RY15		nsp	00D2472008968	CHIP RES.	RM73B--332JT +1608
PY16	RY18		nsp	00D2472006960	CHIP RES.	RM73B--471JT +1608
PY16	RY19		nsp	00D2472007943	CHIP RES.	RM73B--102JT +1608
PY16	RY20		nsp	00D2472007943	CHIP RES.	RM73B--102JT +1608
PY16	RY22		nsp	00D2472005903	CHIP RES.	RM73B--101JT +1608
PY16	RY23		nsp	00D2472007943	CHIP RES.	RM73B--102JT +1608
PY16	RY24		nsp	00D2472007901	CHIP RES.	RM73B--681JT +1608
PY16	RY25		nsp	00D2472012967	CHIP RES.	RM73B--154JT +1608
PY16	RY26		nsp	00D2472009983	CHIP RES.	RM73B--103JT +1608
PY16	RY41		nsp	00D2472005903	CHIP RES.	RM73B--101JT +1608
PY16	SY01		662010001408S	662010001408S	SW	SKHVBF F0052759M
PY16	SY02		662010001408S	662010001408S	SW	SKHVBF F0052759M
PY16	SY03		662010001408S	662010001408S	SW	SKHVBF F0052759M
PY16	SY04		662010001408S	662010001408S	SW	SKHVBF F0052759M
PY16	SY05		662010001408S	662010001408S	SW	SKHVBF F0052759M
PY16	SY06		662010001408S	662010001408S	SW	SKHVBF F0052759M
PY16	SY07		662010001408S	662010001408S	SW	SKHVBF F0052759M
PY16	SY10		662010001408S	662010001408S	SW	SKHVBF F0052759M
PY16	VX01		172010001004M	172010001004M	DISPLAY	CH2163C
PY16	XY01		142010002402S	142010002402S	FILTER	CSTLF4M00G55-A0
PY16	ZY01		2620100010060	2620100010060	PHOTO UNIT	RPM6936-V4 (IR SENSOR)

NOTE : "nsp" PART IS LISTED FOR REFERENCE ONLY, MARANTZ WILL NOT SUPPLY THESE PARTS.

Mecha Loader and Mecha Traverse

Super Audio CD / DVD Player: DV9600

Super Audio CD Player: SA-11S1

SA-15S1

SA7001

SA7001KI

SA8001

SA8400

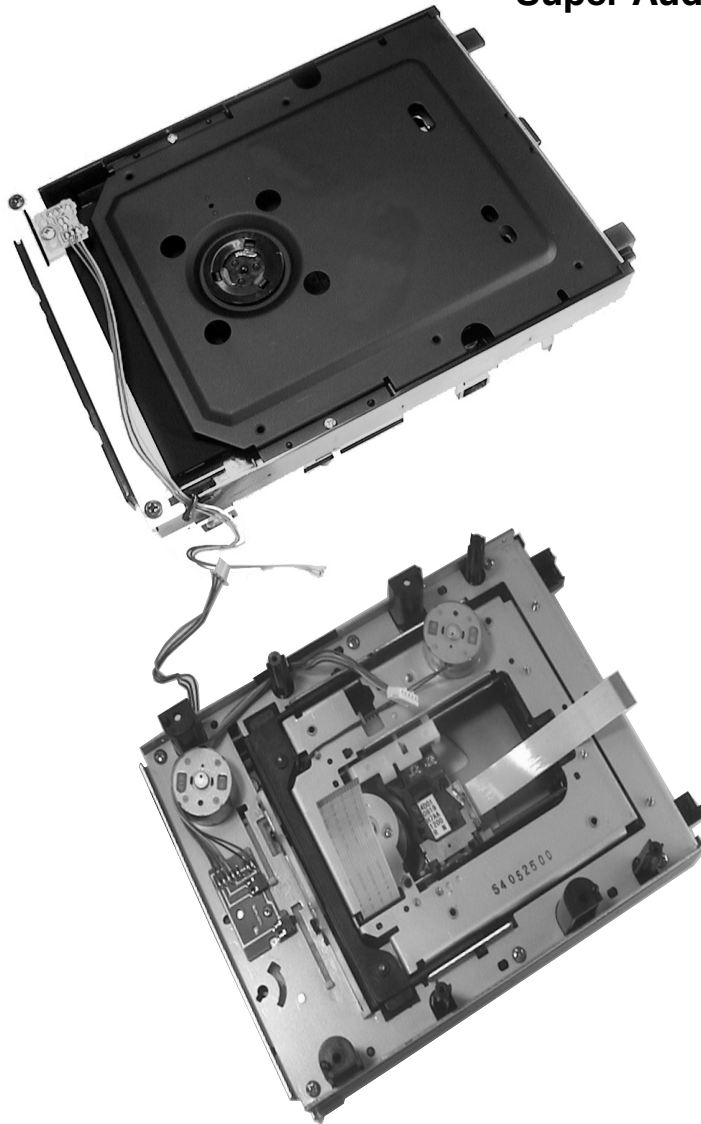

TABLE OF CONTENTS

SECTION 2	PAGE
MECHA LOADER AND MECHA TRAVERSE	
1 EXPLODED VIEW AND PARTS LIST.....	2-2

1. EXPLODED VIEW AND PARTS LIST

PWB NAME	POS. NO.	VERS. COLOR	PART NO. (FOR EUR)	PART NO. (MZ)	PART NAME	DESCRIPTION	
	1		nsp	nsp	CHASSIS	MAIN CHASSIS ASSY	9KC 1A01 7
	2		90M13AK160210	90M13AK160210	BRACKET	CLAMPER BRACKET	9KA 7P08 5
	3		nsp	nsp	BRACKET	GUIDE CLAMP BRACKET	
	4		90M-MM001290R	90M-MM001290R	MOTOR	LOADING MOTOR ASSY	9KC 2A00 3
	5		90M13AK058230	90M13AK058230	GEAR	LOADING GEAR	9KC 2G02 9
	6		90M13AK058210	90M13AK058210	GEAR	LOADING GEAR 2ND	9KB 9G03 0
	7		90M13AK058220	90M13AK058220	GEAR	LOADING GEAR 3RD	9KB 9G03 1
	8		90M13AK105210	90M13AK105210	CHASSIS	SUB CHASSIS-L	9KA 2G41 7
	9		90M13AK105220	90M13AK105220	CHASSIS	SUB CHASSIS-R	9KA 2G41 8
	10		90M13AK163210	90M13AK163210	TRAY	TRAY-D4	9KA 2G778
	11		90M13AK054210	90M13AK054210	CAM	SLIDE-CAM	9KC 1G00 3
	12		90M13AK002210	90M13AK002210	ARM	TRAVERSE ARM	9KC 1G00 4
	14		90M13AK005210	90M13AK005210	CLAMPER	CLAMPER H	9KA 7G20 2
	15		90M13AK005220	90M13AK005220	CLAMPER	CLAMPER L	9KA 7G20 3
	16		90M13AK264210	90M13AK264210	BELT	LOADING BELT	9KB 9G01 5
	17		nsp	nsp	PWB ASSY	SWITCH P.W.B.	9KC 1P01 4
	18		nsp	nsp	CORD	5P PH WIRE	9KC 2G04 3
	19		90M-SP001260R	90M-SP001260R	SWITCH	SWITCH ESE22MH21	9KS 01W2 04
	20		90M-SP001270R	90M-SP001270R	SWITCH	SWITCH ESE22MH23	9KS 01W2 05
	21		90M13AK012210	90M13AK012210	WASHER	POLY.SLIT WASHER 2.6X6X0.25C	9KP 26C6 25
	22		nsp	nsp	CLAMPER	WIRE CLAMPER	445 8004 007
	23		nsp	nsp	SCREW	PRECISION SCREW 1.7X2.2 TYPE3	9KS 17N0 22
	24		nsp	nsp	SCREW	SCREW 2.6X6 CBTS(B)-Z	9KB 26BK 06
	25		nsp	nsp	SCREW	PRECISION SCREW 2X3(S) TYPE3	9KS 20TK 33
	26		nsp	nsp	SCREW	SCREW 2X6 CBTS(P)-Z	9KB 20PK 06
	27A		90M13AK304210	90M13AK304210	MECHANISM	TRAVERSE MECHA (FEED) ASSY	9KC 2A06 3A
	27		nsp	nsp	CHASSIS	PU CHASSIS ASSY	
	28		nsp	nsp	HOLDER	SHAFT HOLDER L	
	29		nsp	nsp	HOLDER	SHAFT HOLDER R	
	30		nsp	nsp	BRACKET	SHAFT TILT BASE	
	31		nsp	nsp	RETAINER	SHAFT TILT PLATE	
	32		nsp	nsp	SPRING	TILT SPRING	
	33		nsp	nsp	SHAFT	MAIN SHAFT	
	34		nsp	nsp	SHAFT	SUB SHAFT	
	35		nsp	nsp	GEAR	PU RACK GEAR	
	36		nsp	nsp	GEAR	FEED GEAR 2ND ASSY	
	37		nsp	nsp	MECHANISM	PICK UP HOP-1200R	
	38		nsp	nsp	SPRING	PU SPRING	
	39		nsp	nsp	SPRING	SHAFT SPRING	
	40		nsp	nsp	SPRING	RACK GEAR SPRING	
	41		nsp	nsp	MOTOR	FEED MOTOR ASSY	
	42		nsp	nsp	MOTOR	T/T MOTOR ASSY	
	43		nsp	nsp	SCREW	SCREW 2.6X6 CBTS(S)-Z	
	44		nsp	nsp	SCREW	SCREW 2.6X4 CBTS(S)-Z	
	46		nsp	nsp	SCREW	SCREW 2.6X15 CFTS(S)-Z	
	47		nsp	nsp	SCREW	SCREW 3X4 BSS	
	48		nsp	nsp	SCREW	SCREW 3X8 BSS (A)	
	49		90M13AK130220	90M13AK130220	DAMPER	DAMPER-IDLE HARD-40	C2G083B
	50		nsp	nsp	WASHER	POLY.SLIT WASHER 2.1X4X0.25C	
	51		nsp	nsp	SCREW	SPECIAL SCREW (FRONT)	
	52		nsp	nsp	SCREW	SPECIAL SCREW (REAR)	
	53		nsp	nsp	GEAR	FEED GEAR 3RD	
	54		90M13AK116210	90M13AK116210	LEAF SPRING	TRAY-SPRING-VXF	9KB 7P02 4
	60		90M13AK104210	90M13AK104210	RETAINER	PLATE-RE-2HPC	9KC 2P03 1
	61		90M13AK104220	90M13AK104220	RETAINER	WF-PLATE-RE-2HPC	9KC 2P03 2
	62		nsp	nsp	SCREW	PRECISION SCREW 2X4(P) TYPE1	9KS 20P1 04
	63		nsp	nsp	SCREW	PRECISION SCREW 1.7X5 TYPE3	
	64		nsp	nsp	CUSHION	RUBBER CUSHION	9KC 1G04 2
	66		90M-YU001350R	90M-YU001350R	FFC	FFC-0.5-24 L=80	9KA 2P70 6
	68		nsp	nsp	TAPE	TAPE W10X45 (NITTO NO.156)	
	70		nsp	nsp	CUSHION	CUSHION L 6X3Xt4	9KC 2G07 6
	71		nsp	nsp	CUSHION	CUSHION R 6X3Xt2	9KC 2G07 7

NOTE : "nsp" PART IS LISTED FOR REFERENCE ONLY, MARANTZ WILL NOT SUPPLY THESE PARTS.

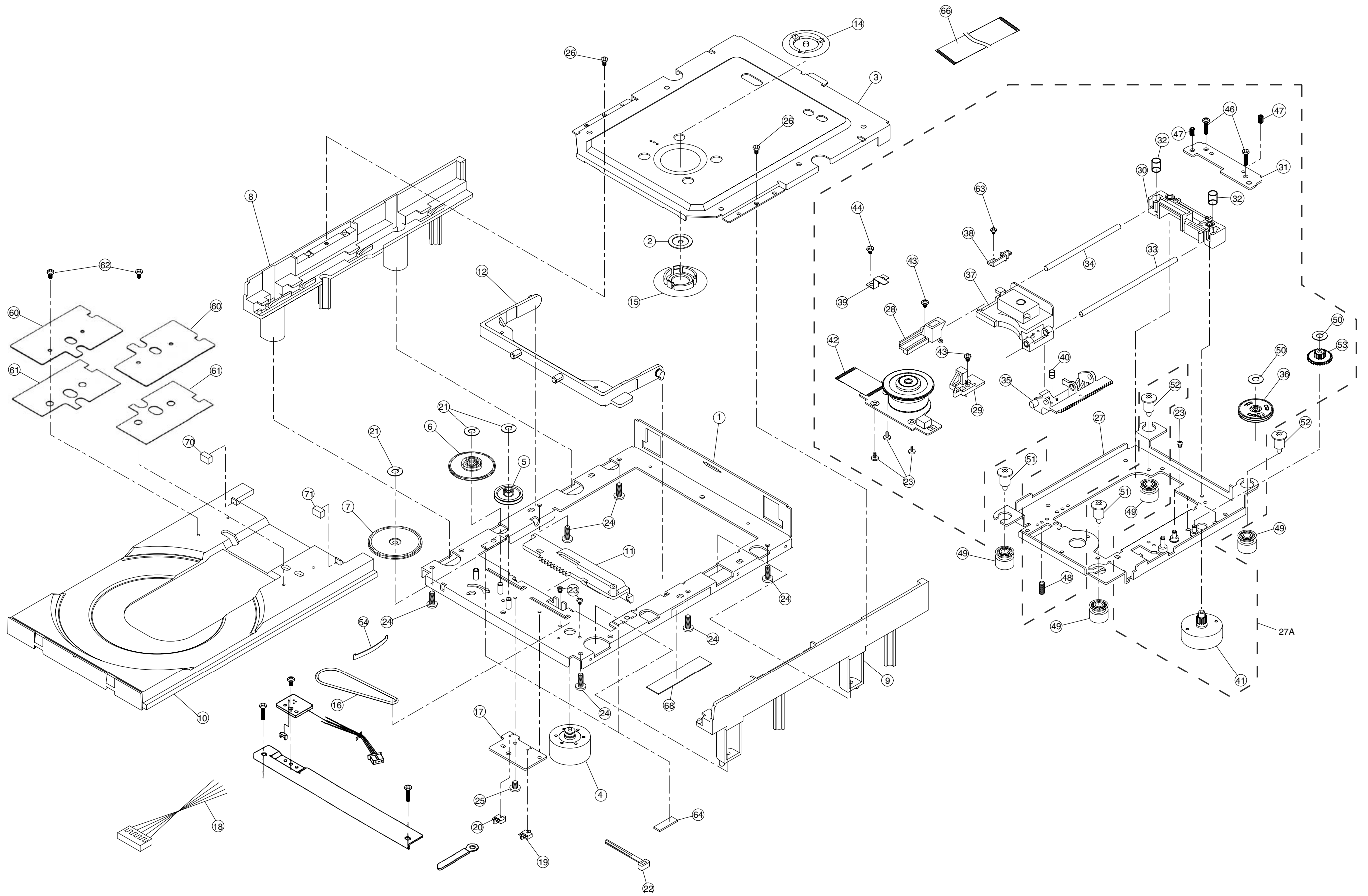

Super Audio CD PWB Module

Super Audio CD Player : SA7001
SA7001KI
SA8001

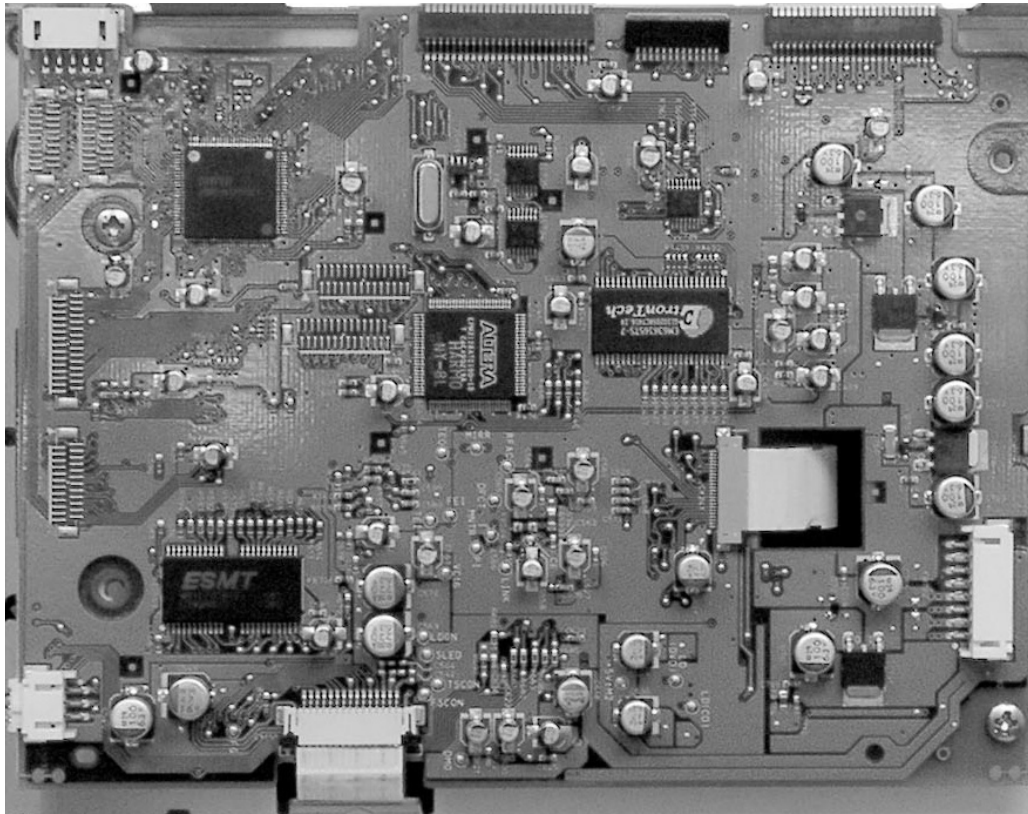
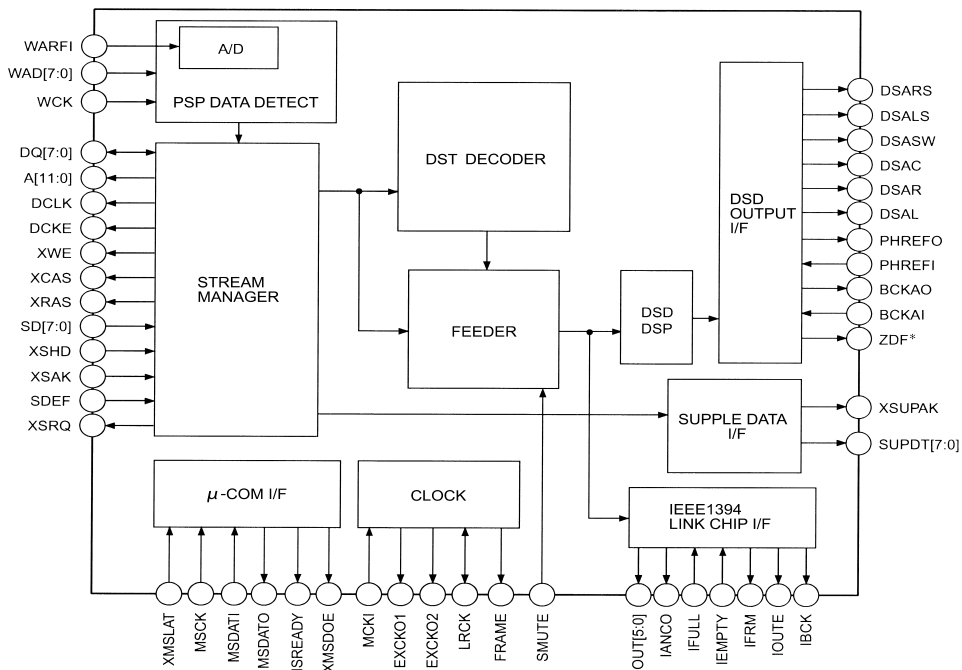
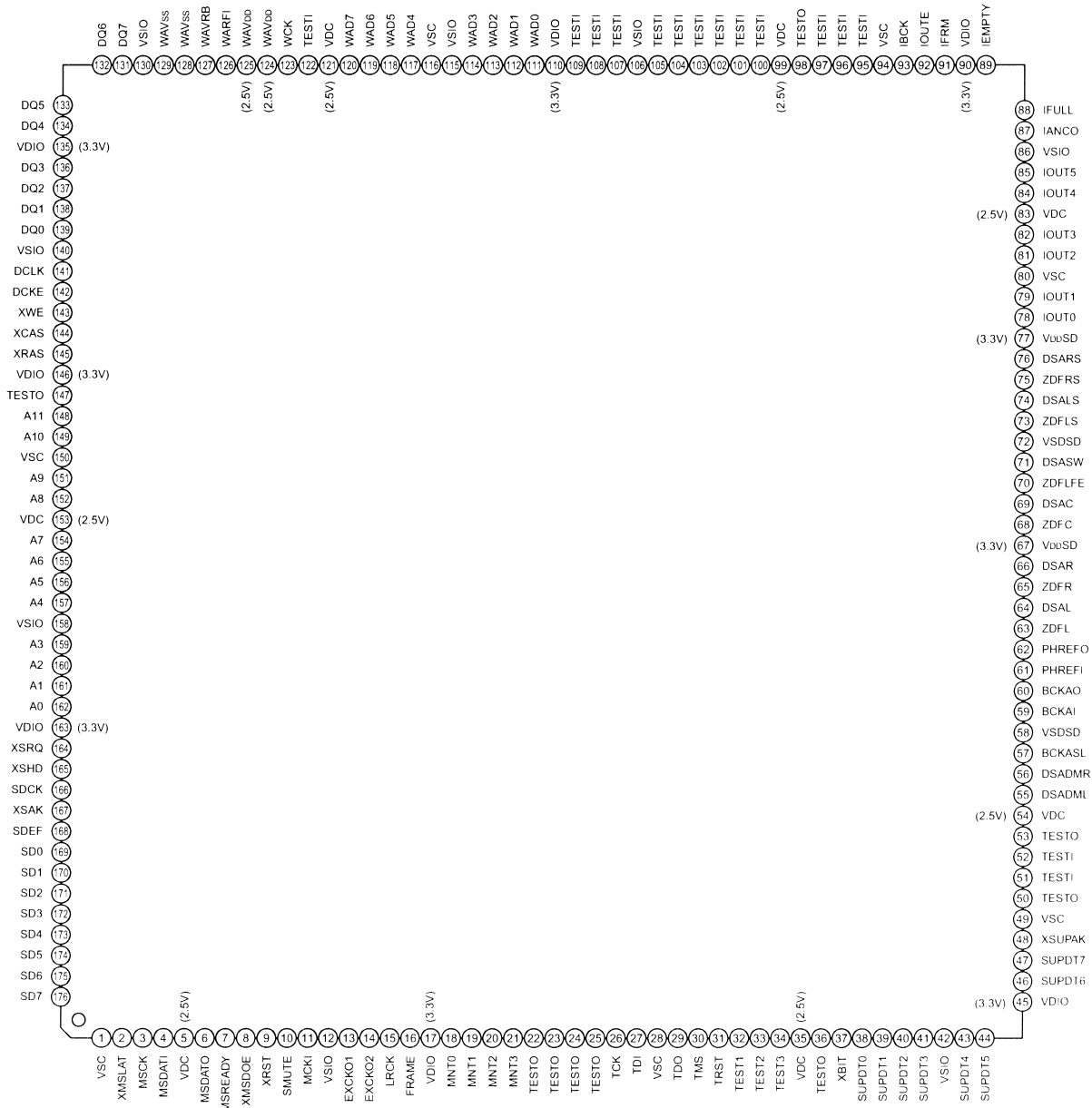

TABLE OF CONTENTS

SECTION 3	PAGE
SUPER AUDIO CD PWB MODULE	
1. IC DATA	3-2
2. BLOCK DIAGRAM	3-23
3. SCHEMATIC DIAGRAM.....	3-25
4. PARTS LOCATION.....	3-37
5. ELECTRICAL PARTS LIST	3-41

1. IC DATA

IC401: CXD2753R



IC401: CXD2753R

No.	Pin Name	I/O	Functions
1	VSC	-	It fixed to ground.(for Core)
2	XMSLAT	I	Latch input for mCOM serial communication.
3	MSCK	I	Shift clock input for mCOM serial communication.
4	MSDATI	I	Data input for mCOM serial communication.
5	VDC	-	+2.5V Power for Core.
6	MSDATO	O	Data output for mCOM serial communication. "Hi-Z" potential except the output mode.
7	MSREADY	O	Completion flag of output preparation for mCOM serial communication. "L" is outputted at the time of completion.
8	XMSDOE	O	Output enable pin for mCOM serial communication. "L" is outputted at the time of MSDATO mode.
9	XRST	I	Reset pin. The whole IC is reset by at the time of "L" potential.
10	SMUTE	lpd	Soft Mute. Soft mute of the audio output is carried out at the time of "H" potential.It releases at the time of "L" potential.
11	MCKI	I	Master Clock input.
12	VSIO	-	It fixed to Ground. Ground for I/O.
13	EXCKO1	O	External output Clock 1.
14	EXCKO2	O	External output Clock 2.
15	LRCK	O	44.1kHz, 1Fs Clock output.
16	FRAME	O	Frame signal output.
17	VDIO	-	+3.3V Power for I/O.
18	MNT0	O	Monitor output.
19	MNT1	O	Monitor output.
20	MNT2	O	Monitor output.
21	MNT3	O	Monitor output.
22	TESTO	O	Output terminal for a Test. (open)
23	TESTO	O	Output terminal for a Test.(open)
24	TESTO	O	Output terminal for a Test.(open)
25	TESTO	O	Output terminal for a Test.(open)
26	TCK	I	Clock input for a Test. It fixed to "L" potential.
27	TDI	lpu	Input pin(pull-up) for a Test.(open)
28	VSC	-	It fixed to Ground. Ground for CORE.
29	TDO	O	Output for a Test.(open).
30	TMS	lpu	Input pin(pull-up) for a Test.(open)
31	TRST	lpu	Reset pin(pull-up) for a Test. Input the Power-on reset signal or fixed to "L" potential.
32	TEST1	I	Test input pin. It fixed to "L" potential.
33	TEST2	I	Test input pin. It fixed to "L" potential.
34	TEST3	I	Test input pin. It fixed to "L" potential.
35	VDC	-	+2.5V Power for CORE.
36	TESTO	O	Out put for TEST. It fixed to open.
37	XBIT	O	DST monitor.
38	SUPDT0	O	Supplementary data output. (LSB)
39	SUPDT1	O	Supplementary data output.
40	SUPDT2	O	Supplementary data output.
41	SUPDT3	O	Supplementary data output.
42	VSIO	-	Ground for I/O.
43	SUPDT4	O	Supplementary data output.
44	SUPDT5	O	Supplementary data output.
45	VDIO	-	+3.3V Power for I/O.
46	SUPDT6	O	Supplementary data output.
47	SUPDT7	O	Supplementary data output. (MSB)
48	XSUPAK	O	Supplementary data Acknowledge output terminal.
49	VSC	-	Ground for CORE.
50	TESTO	O	Output for TEST. (open)
51	TESTI	I	Input for TEST. It fixed to "L" potential.
52	TESTI	I	Input for TEST. It fixed to "L" potential.
53	TESTO	O	Output for TEST. (open)
54	VDC	-	+2.5V Power for CORE.
55	DSADML	O	DSD Data output terminal for Lch Down Mix.
56	DSADMR	O	DSD Data output terminal for Rch Down Mix.
57	BCKASL	I	I/O selection terminal of the Bit clock for DSD data output. L=input (Slave), H=output (Master)
58	VSDSD	-	Ground terminal for DSD data output.
59	BCKAI	I	Bit clock input terminal for DSD data output. Input a Bit clock into this terminal at the time of BCKASL="L" potential.
60	BCKAO	O	Bit clock output terminal for DSD data output. Bit clock output from this terminal at the time of BCKASL="H" potential.
61	PHREFI	I	Reference phase signal input terminal for DSD output phase modulation.
62	PHREFO	O	Reference phase signal output terminal for DSD output phase modulation.

IC401: CXD2753R

No.	Pin Name	I/O	Functions
63	ZDFL	O	Lch zero-data detection flag (at the time of mcom setup). It will be set to "H" if non-sound data continues 300 msecs.
64	DSAL	O	DSD data output terminal for Lch speaker.
65	ZDFR	O	Rch zero-data detection flag (at the time of mcom setup). It will be set to "H" if non-sound data continues 300 msecs.
66	DSAR	O	DSD data output terminal for Rch speaker.
67	VDDSD	-	+3.3V Power for DSD data output.
68	ZDFC	O	Cch zero-data detection flag (at the time of mcom setup). It will be set to "H" if non-sound data continues 300 msecs.
69	DSAC	O	DSD data output terminal for Cch speaker.
70	ZDFLFE	O	LFEch zero-data detection flag (at the time of mcom setup). It will be set to "H" if non-sound data continues 300 msecs.
71	DSASW	O	DSD data output terminal for SWch speaker.
72	VSDSD	-	Ground for DSD data output.
73	ZDFLS	O	LSch zero-data detection flag (at the time of mcom setup). It will be set to "H" if non-sound data continues 300 msecs.
74	DSALS	O	DSD data output terminal for LSch speaker.
75	ZDFRS	O	RSch zero-data detection flag (at the time of mcom setup). It will be set to "H" if non-sound data continues 300 msecs.
76	DSARS	O	DSD data output terminal for RSch speaker.
77	VDDSD	O	+3.3V Power for DSD data output.
78	IOUT0	O	Data output terminal 0 for IEEE1394 link chip I/F.
79	IOUT1	O	Data output terminal 1 for IEEE1394 link chip I/F.
80	VSC	-	Ground for CORE.
81	IOUT2	O	Data output terminal 2 for IEEE1394 link chip I/F.
82	IOUT3	O	Data output terminal 3 for IEEE1394 link chip I/F.
83	VDC	-	+2.5V Power for CORE.
84	IOUT4	O	Data output terminal 4 for IEEE1394 link chip I/F.
85	IOUT5	O	Data output terminal 5 for IEEE1394 link chip I/F.
86	VSIO	-	Ground for I/O.
87	IANCO	O	Transmission information data output terminal for IEEE1394 link chip I/F.
88	IFULL	I	Data transmission hold request signal input terminal for IEEE1394 link chip I/F.
89	IEMPTY	I	High speed transmission request signal input terminal for IEEE1394 link chip I/F.
90	VDIO	-	+3.3V Power for I/O.
91	IFRM	O	Frame reference signal output terminal for IEEE1394 link chip I/F.
92	IOUTE	O	Enable signal output terminal for IEEE1394 link chip I/F.
93	IBCK	O	Data transmission clock output terminal for IEEE1394 link chip I/F.
94	VSC	-	Ground for CORE.
95	TESTI	I	TEST input terminal. It fixed to "H" potential.
96	TESTI	I	TEST input terminal. It fixed to "L" potential.
97	TESTI	Ipu	TEST input terminal. It fixed to "H" potential.
98	TESTO	O	TEST output terminal. (open)
99	VDC	-	+2.5V Power for CORE.
100	TESTI	I	TEST input terminal. It fixed to "L" potential.
101	TESTI	I	TEST input terminal. It fixed to "L" potential.
102	TESTI	I	TEST input terminal. It fixed to "L" potential.
103	TESTI	I	TEST input terminal. It fixed to "L" potential.
104	TESTI	I	TEST input terminal. It fixed to "L" potential.
105	TESTI	I	TEST input terminal. It fixed to "L" potential.
106	VSIO	-	Ground for I/O.
107	TESTI	I	TEST input terminal. It fixed to "L" potential.
108	TESTI	I	TEST input terminal. It fixed to "L" potential.
109	TESTI	I	TEST input terminal. It fixed to "L" potential.
110	VDIO	-	+3.3V Power for I/O.
111	WAD0	I	External A/D data input terminal(LSB) for PSP physical disc mark detection.
112	WAD1	I	External A/D data input terminal for PSP physical disc mark detection.
113	WAD2	I	External A/D data input terminal for PSP physical disc mark detection.
114	WAD3	I	External A/D data input terminal for PSP physical disc mark detection.
115	VSIO	-	Ground for I/O.
116	VSC	-	Ground for CORE.
117	WAD4	I	External A/D data input terminal for PSP physical disc mark detection.
118	WAD5	I	External A/D data input terminal for PSP physical disc mark detection.
119	WAD6	I	External A/D data input terminal for PSP physical disc mark detection.
120	WAD7	I	External A/D data input terminal(MSB) for PSP physical disc mark detection.
121	VDC	-	+2.5V Power for CORE.
122	TESTI	I	TEST input terminal. It fixed to "L" potential.

IC401: CXD2753R

No.	Pin Name	I/O	Functions
123	WCK	I	Operation clock for PSP physical disc mark detection.
124	WAVDD	-	+2.5V Power. A/D Power supply for PSP physical disc mark detection.
125	WAVDD	-	+2.5V Power. A/D Power supply for PSP physical disc mark detection.
126	WARFI	Ai	Analog RF signal input terminal for PSP physical disc mark detection.
127	WAVRB	Ai	A/D bottom reference terminal for PSP physical disc mark detection.
128	WAVSS	-	A/D Ground terminal for PSP physical disc mark detection.
129	WAVSS	-	A/D Ground terminal for PSP physical disc mark detection.
130	VSIO	-	Ground for I/O.
131	DQ7	I/O	SDRAM data input/output terminal. (MSB)
132	DQ6	I/O	SDRAM data input/output terminal.
133	DQ5	I/O	SDRAM data input/output terminal.
134	DQ4	I/O	SDRAM data input/output terminal.
135	VDIO	-	+3.3V Power for I/O.
136	DQ3	I/O	SDRAM data input/output terminal.
137	DQ2	I/O	SDRAM data input/output terminal.
138	DQ1	I/O	SDRAM data input/output terminal.
139	DQ0	I/O	SDRAM data input/output terminal. (LSB)
140	VSIO	-	Ground for I/O.
141	DCLK	O	Clock output terminal for SDRAM.
142	DCKE	O	Clock enable output terminal for SDRAM.
143	XWE	O	Write enable output terminal for SDRAM.
144	XCAS	O	Column address strobe output terminal for SDRAM.
145	XRAS	O	Row address strobe output terminal for SDRAM.
146	VDIO	-	+3.3V Power for I/O.
147	TESTO	O	Output terminal for TEST. (open)
148	A11	O	Address output terminal for SDRAM. (MSB)
149	A10	O	Address output terminal for SDRAM.
150	VSC	-	Ground for CORE.
151	A9	O	Address output terminal for SDRAM.
152	A8	O	Address output terminal for SDRAM.
153	VDC	-	+2.5V Power for CORE.
154	A7	O	Address output terminal for SDRAM.
155	A6	O	Address output terminal for SDRAM.
156	A5	O	Address output terminal for SDRAM.
157	A4	O	Address output terminal for SDRAM.
158	VSIO	-	Ground for I/O.
159	A3	O	Address output terminal for SDRAM.
160	A2	O	Address output terminal for SDRAM.
161	A1	O	Address output terminal for SDRAM.
162	A0	O	Address output terminal for SDRAM. (LSB)
163	VDIO	-	+3.3V Power for I/O.
164	XSRQ	O	Output terminal of the Data Request signal inputted a front-end processor.
165	XSHD	I	Input terminal of the header Flag outputted from a front-end processor.
166	SDCK	I	Input terminal of the data conveyance Clock outputted from a front-end processor.
167	XASK	I	Input terminal of the data valid Flag outputted from a front-end processor.
168	SDEF	I	Input terminal of the error Flag outputted from a front-end processor.
169	SD0	I	Input terminal of the stream Data outputted from a front-end processor.
170	SD1	I	Input terminal of the stream Data outputted from a front-end processor.
171	SD2	I	Input terminal of the stream Data outputted from a front-end processor.
172	SD3	I	Input terminal of the stream Data outputted from a front-end processor.
173	SD4	I	Input terminal of the stream Data outputted from a front-end processor.
174	SD5	I	Input terminal of the stream Data outputted from a front-end processor.
175	SD6	I	Input terminal of the stream Data outputted from a front-end processor.
176	SD7	I	Input terminal of the stream Data outputted from a front-end processor.

Ipu: Pull-up input Ipd: Pull-down input Ai: Analog input

IC402: 16M SDRAM (EM636165TS-7 etc)

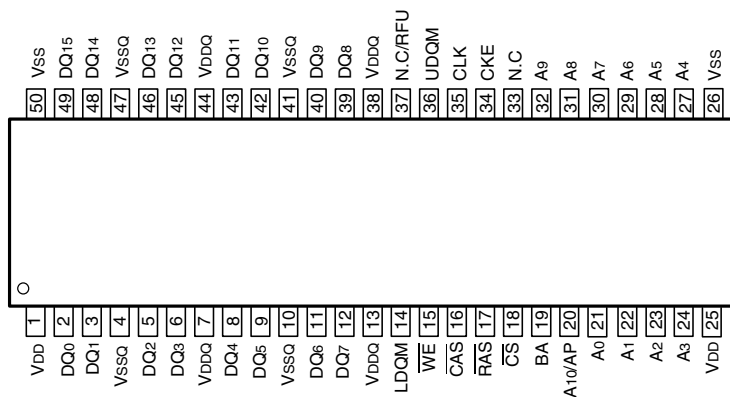

Terminal Function

Pin No.	Pin Name	Symbol	Function
1	VDD	Power Supply/Ground	Power and ground for the input buffer and the core logic
2	DQ0	Data Input/Output	Data input/output are multiplexed on the same pin
3	DQ1	Data Input/Output	Data input/output are multiplexed on the same pin
4	VSSQ	Data Output Power/Ground	Isolated power supply and ground for the output buffer
5	DQ2	Data Input/Output	Data input/output are multiplexed on the same pin
6	DQ3	Data Input/Output	Data input/output are multiplexed on the same pin
7	VDDQ	Data Output Power/Ground	Isolated power supply and ground for the output buffer
8	DQ4	Data Input/Output	Data input/output are multiplexed on the same pin
9	DQ5	Data Input/Output	Data input/output are multiplexed on the same pin
10	VSSQ	Data Output Power/Ground	Isolated power supply and ground for the output buffer
11	DQ6	Data Input/Output	Data input/output are multiplexed on the same pin
12	DQ7	Data Input/Output	Data input/output are multiplexed on the same pin
13	VDDQ	Data Output Power/Ground	Isolated power supply and ground for the output buffer
14	LDQM	Data Input/Output Mask	Blocks data input when active
15	WE	Write Enable	Enables write operation and row precharge
16	CAS	Column Address Strobe	Latches column address on the positive going edge of the CLK at low
17	RAS	Row Address Strobe	Latches row address on the positive going edge of the CLK at low
18	CS	Chip Select	Disables or enables device operation by masking or enabling all inputs except CLK, CKE, and LDQM
19	BA	Bank Select Address	Selects bank to be activated during row address latch time
20	A10/AP	Address	Row/column addresses are multiplexed on the same pin
21	A0	Address	Row/column addresses are multiplexed on the same pin
22	A1	Address	Row/column addresses are multiplexed on the same pin
23	A2	Address	Row/column addresses are multiplexed on the same pin
24	A3	Address	Row/column addresses are multiplexed on the same pin
25	VDD	Power Supply/Ground	Power and ground for the input buffer and the core logic
26	VSS	Power Supply/Ground	Power and ground for the input buffer and the core logic
27	A4	Address	Row/column addresses are multiplexed on the same pin
28	A5	Address	Row/column addresses are multiplexed on the same pin
29	A6	Address	Row/column addresses are multiplexed on the same pin
30	A7	Address	Row/column addresses are multiplexed on the same pin
31	A8	Address	Row/column addresses are multiplexed on the same pin
32	A9	Address	Row/column addresses are multiplexed on the same pin
33	N.C	No Connection	No connect pin
34	CKE	Clock Enable	Masks system clock to freeze operation from the next clock cycle
35	CLK	System Clock	Active on the positive going edge to sample all inputs
36	UDQM	Data Input/Output Mask	Blocks data input when active
37	N.C/RFU	NC/Reserved	No connect pin
38	VDDQ	Data Output Power/Ground	Isolated power supply and ground for the output buffer
39	DQ8	Data Input/Output	Data input/output are multiplexed on the same pin
40	DQ9	Data Input/Output	Data input/output are multiplexed on the same pin
41	VSSQ	Data Output Power/Ground	Isolated power supply and ground for the output buffer
42	DQ10	Data Input/Output	Data input/output are multiplexed on the same pin
43	DQ11	Data Input/Output	Data input/output are multiplexed on the same pin
44	VDDQ	Data Output Power/Ground	Isolated power supply and ground for the output buffer
45	DQ12	Data Input/Output	Data input/output are multiplexed on the same pin
46	DQ13	Data Input/Output	Data input/output are multiplexed on the same pin
47	VSSQ	Data Output Power/Ground	Isolated power supply and ground for the output buffer
48	DQ14	Data Input/Output	Data input/output are multiplexed on the same pin
49	DQ15	Data Input/Output	Data input/output are multiplexed on the same pin
50	VSS	Power Supply/Ground	Power and ground for the input buffer and the core logic

IC501: CDX1881AR

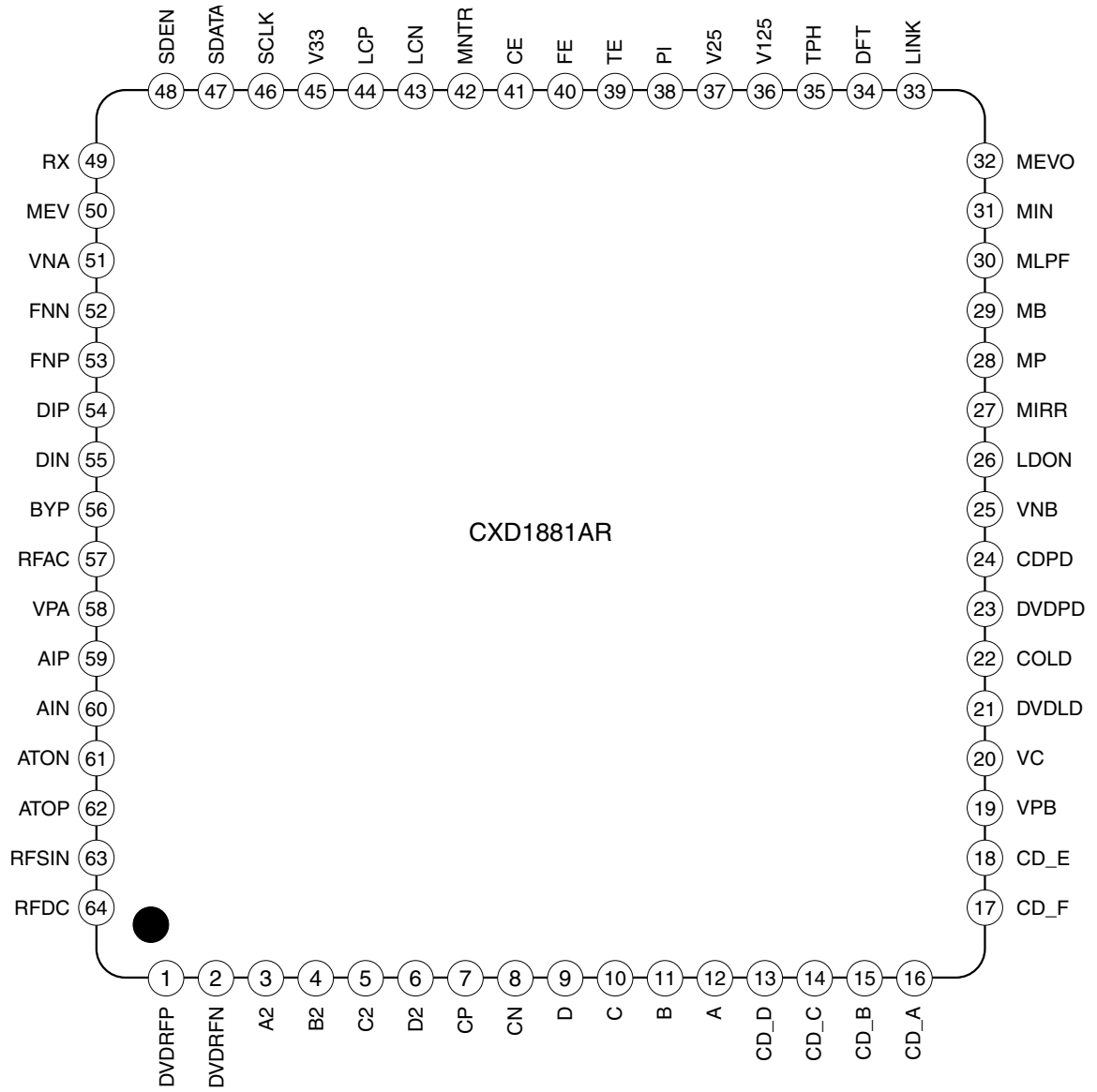

IC501: CDX1881AR

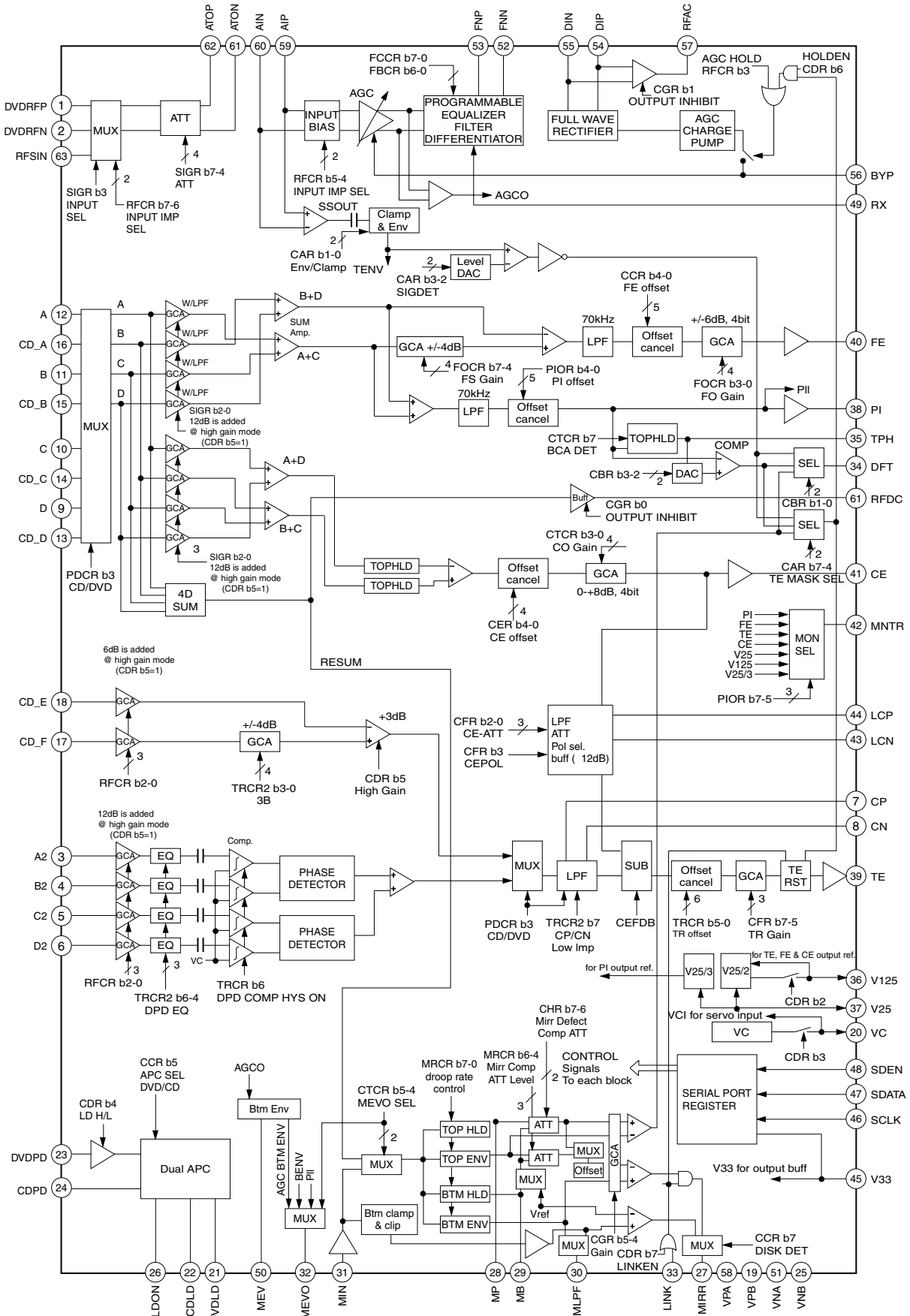

IC501: CDX1881AR

Power Supply Pins

Name	I/O	Function
VPA	-	Power for RF and serial port
VPB	-	Power for servo
VNA	-	GND for RF and serial port
VNB	-	GND for servo
V33	-	Power for output buffer
V25	-	Reference Power for servo output

Input Pins

Name	I/O	Function
DVDRFP, DVDRFN	I	RF signal input
RFSIN	I	RF signal input
AIP,AIN	I	AGC amp. input
DIP,DIN	I	Analog input for RF single buffer
A,B,C,D	I	Photo detector interface input
A2, B2, C2, D2	I	Photo detector interface input
CD_A, B, C, D	I	CD photo detector interface input
CD_E, F	I	CD photo detector interface input
MIN	I	RF signal input for mirror
DVDPD	I	APC input
CDPD	I	APC input
LDON	I	APC input ON/OFF (L:Open)
	I	Link signal input (L:Open)
	O	Mirror monitor output

Output Pins

Name	I/O	Function
ATOP,ATON	O	Differential attenuator output
FNP,FNN	O	Differential normal output
RFAC	O	Single end normal output
RFDC	O	RF signal output
FE	O	Focus error signal output
TE	O	Tracking error signal output
CE	O	Center error signal output
MEVO	O	RFDDC bottom envelope output
DFT	O	Defect output
MIRR	O	Mirror detected output
PI	O	Pull-in signal output
DVDLD	O	APC output
CDLD	O	APC output
MNTR	O	Monitor output

Analog Pins

Name	I/O	Function
BYP	-	RF AGC integration capacitor connecting terminal
CP	-	Differential phase tracking LPF terminal
CN	-	Differential phase tracking LPF terminal
LCP	-	Lens shift offset cancel LPF terminal
LCN	-	Lens shift offset cancel LPF terminal
MP	-	MIRR top hold terminal
MB	-	MIRR bottom hold terminal
MEV	-	RFDC bottom envelope terminal
MLPF	-	Mirror LPF terminal
TPH	-	PI top hold terminal
VC	-	Reference voltage output
V125	-	Reference voltage output
RX	-	Reference resistor input

Serial Port Pins

Name	I/O	Function
SDEN	I	Serial data enable
SDATA	I/O	Serial data
SCLK	I	Serial clock

IC502: CXD1885Q

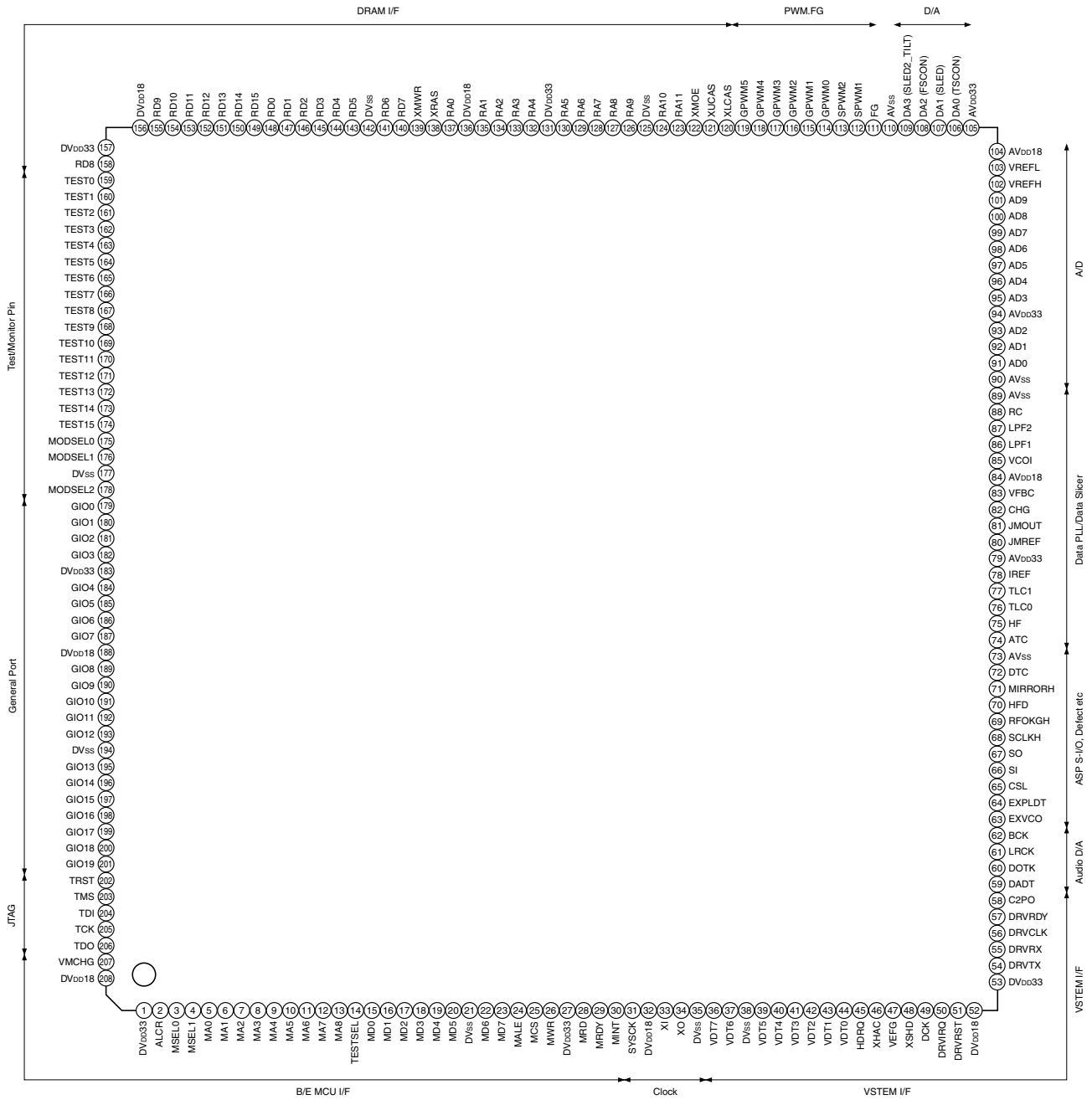

IC502: CXD1885Q

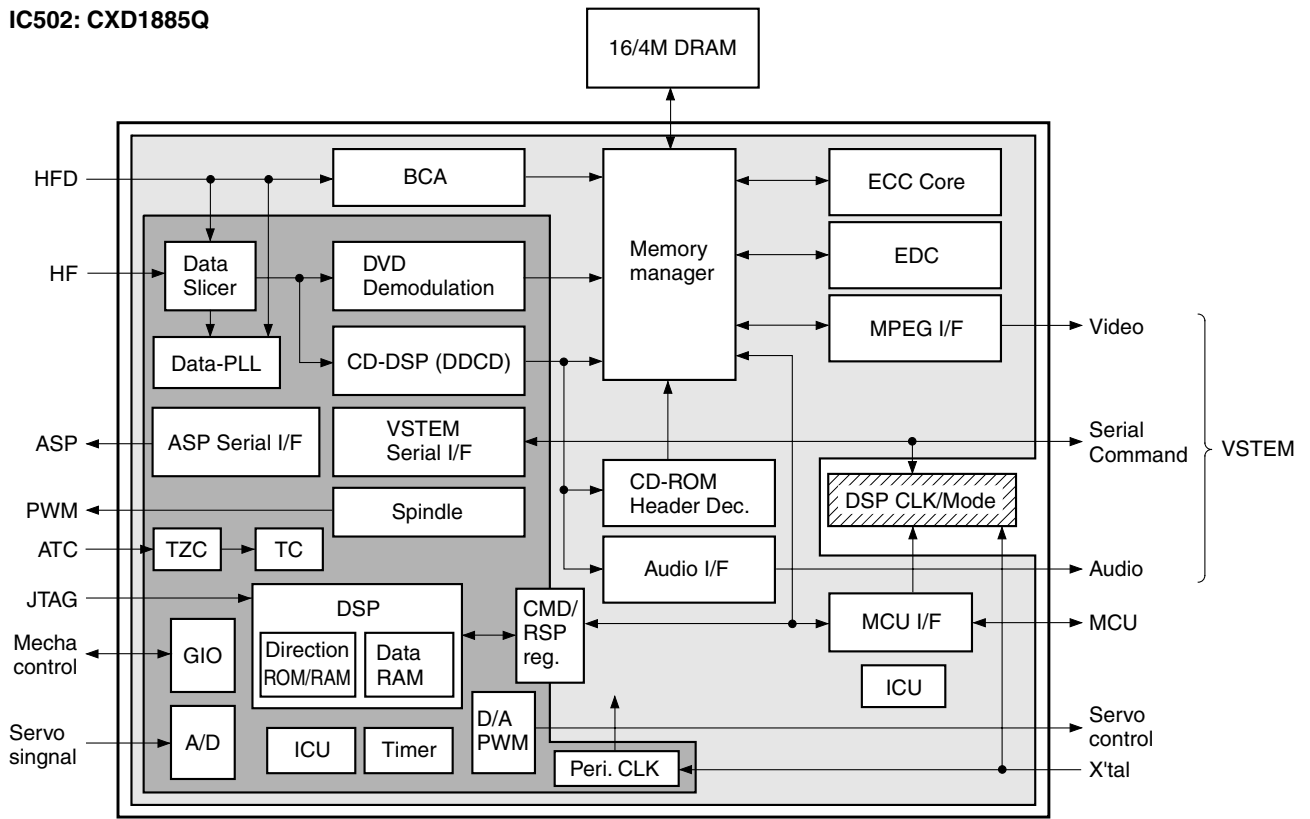

(A/D : Analog/Digital, PU : Pull-up, PD : Pull-down, SMT=Schmitt)

No.	Terminal Name	I/O	A/D	Classification	Function	PU	PD	SMT
1	DVDD33	P		VDD & GND	Digital 3.3V Power for I/O.			
2	ALCR	I	D	MCU I/F	Chip select input. (L: Reset)	*		*
3	MSEL0	I	D	MCU I/F	MCU I/F mode select 0.			*
4	MSEL1	I	D	MCU I/F	MCU I/F mode select 1.			*
5	MA0	I/O	D	MCU I/F	MCU Address input 0 / data I/O 0 <LSB>.			*
6	MA1	I/O	D	MCU I/F	MCU Address input 1 / data I/O 1.			*
7	MA2	I/O	D	MCU I/F	MCU Address input 2 / data I/O 2.			*
8	MA3	I/O	D	MCU I/F	MCU Address input 3 / data I/O 3.			*
9	MA4	I/O	D	MCU I/F	MCU Address input 4 / data I/O 4.			*
10	MA5	I/O	D	MCU I/F	MCU Address input 5 / data I/O 5.			*
11	MA6	I/O	D	MCU I/F	MCU Address input 6 / data I/O 6.			*
12	MA7	I/O	D	MCU I/F	MCU Address input 7 / data I/O 7.			*
13	MA8	I	D	MCU I/F	MCU Address input 8 <MSB>.			*
14	TESTSEL	I	D	MCU I/F	TEST Select input.			*
15	MD0	I/O	D	MCU I/F	MCU data I/O 0 <LSB>.			*
16	MD1	I/O	D	MCU I/F	MCU data I/O 1.			*
17	MD2	I/O	D	MCU I/F	MCU data I/O 2.			*
18	MD3	I/O	D	MCU I/F	MCU data I/O 3.			*
19	MD4	I/O	D	MCU I/F	MCU data I/O 4.			*
20	MD5	I/O	D	MCU I/F	MCU data I/O 5.			*
21	DVSS	P		VDD & GND	Digital Ground.			
22	MD6	I/O	D	MCU I/F	MCU data I/O 6.			*
23	MD7	I/O	D	MCU I/F	MCU data I/O 7 <MSB>.			*
24	MALE	I	D	MCU I/F	MCU Address latch signal input.			*
25	MCS	I	D	MCU I/F	MCU Chip Select signal input.			*
26	MWR	I	D	MCU I/F	MCU Write strobe signal.			*
27	DVDD18	P		VDD & GND	digital 3.3V Power. (for I/O)			
28	MRD	I	D	MCU I/F	MCU Read Strobe signal.			*
29	MRDY	O	D	MCU I/F	MCU Ready signal. (L: Wait)			
30	MINT	O	D	MCU I/F	MCU Interrupt signal. (L: Interrupt request)			
31	SYSCK	O	D	Clock	Clock Monitor output.			
32	DVDD18	P		VDD & GND	Digital 1.8V Power. (Internal logic system power)			
33	XI	I	D	Clock	Crystal oscillation input.			
34	XO	O	D	Clock	Crystal oscillation output.			
35	DVSS	P		VDD & GND	Digital Ground.			
36	VDT7	O	D	VSTEM A/V	MPEG data output 7.			
37	VTD6	O	D	VSTEM A/V	MPEG data output 6.			

IC502: CXD1885Q

No.	Terminal Name	I/O	A/D	Classification	Function	PU	PD	SMT
38	DVSS	P		VDD & GND	Digital Ground.			
39	VDT5	O	D	VSTEM A/V	MPEG data output 5.			
40	VDT4	O	D	VSTEM A/V	MPEG data output 4.			
41	VDT3	O	D	VSTEM A/V	MPEG data output 3.			
42	VDT2	O	D	VSTEM A/V	MPEG data output 2.			
43	VDT1	O	D	VSTEM A/V	MPEG data output 1.			
44	VDT0	O	D	VSTEM A/V	MPEG data output 0.			
45	HDRQ	I	D	VSTEM A/V	MPEG data Request input.	*		
46	XHAC	O	D	VSTEM A/V	Data Valid output.			
47	VEFG	O	D	VSTEM A/V	ECC Error-sector Flag output. (L: error sector)			
48	XSHD	O	D	VSTEM A/V	DVD Sector Head Flag output.			
49	DCK	O	D	VSTEM A/V	Data Strobe output.			
50	DRVIRQ	O	D	VSTEM Command	Interrupt Request output for Host. (L: interruption is demanded)			
51	DRVRST	I	D	VSTEM Command	Drive H/W Reset input. (L: reset)	*		*
52	DVDD18	P		VDD & GND	Digital 1.8V power for Internal logic system.			
53	DVDD33	P		VDD & GND	Digital 3.3V Power for I/O.			
54	DRVTX	O	D	VSTEM Command	Transmitting serial data output to Host.			
55	DRVRX	I	D	VSTEM Command	Reception serial data input from Host.			
56	DRVCLK	I	D	VSTEM Command	Clock input from Host.			*
57	DRVRDY	O	D	VSTEM Command	Drive Ready signal output. (L: ready)			
58	C2PO	O	D	Audio I/F	CD-DSP C2 Pointer output.			
59	DADT	O	D	Audio I/F	Audio serial data output.			
60	DOTX	O	D	Audio I/F	Digital audio output.			
61	LRCK	O	D	Audio I/F	L/R Clock output.			
62	BCK	O	D	Audio I/F	Audio Bit Clock output.			
63	EXVCO	I	D	TEST/Monitor	External Channel clock input.			
64	EXPLDT	I	D	TEST/Monitor	External RF data input. (Logic level)			
65	CSL	O	D	ASP I/F	SIO for RF signal processing LSI control. Latch signal output.			
66	SI	I	D	ASP I/F	SIO for RF signal processing LSI control. Serial data input.			
67	SO	O	D	ASP I/F	SIO for RF signal processing LSI control. Serial data output.			
68	SCLKH	O	D	ASP I/F	SIO for RF signal processing LSI control. Serial clock output.			
69	RFOKGH	I	D	ASP I/F	RF O.K. Signal input.			*
70	HFD	I	D	ASP I/F	RF lack Signal input.			*
71	MIRRORH	I	D	ASP I/F	Mirror detected signal input.(H: Mirror detected)			*
72	DTC	I	D	ASP I/F	Track cross signal input. (Logic level input)			*
73	AVSS	P		VDD & GND	Analog Ground.			
74	ATC	I	A	Data PLL	Track Cross signal input. (Analog level input)			
75	HF	I	A	Data PLL	RF signal input.			
76	TLC0	O	A	Data PLL	Asymmetry Charge-pump output 0.			
77	TLC1	O	A	Data PLL	Asymmetry Charge-pump output 1			
78	IREF	I	A	Data PLL	Reference current setting terminal for Asymmetry Circuit.			
79	AVDD33	P		VDD & GND	Analog 3.3V Power.			
80	JMREF	I	A	Data PLL	Reference current setting terminal for Jitter Monitor			
81	JMOUT	O	A	Data PLL	Jitter Monitor output.			
82	CHG	I	A	Data PLL	Reference current setting terminal for data PLL.			
83	VFBC	I	A	Data PLL	VCO offset frequency setting terminal for data PLL.			
84	AVDD18	P		VDD & GND	Analog 1.8V Power.			
85	VCOI	I	A	Data PLL	VCO Control voltage input terminal for data PLL.			
86	LPF1	O	A	Data PLL	VCO Loop-filter connection terminal 1 for data PLL.			
87	LPF2	O	A	Data PLL	VCO Loop-filter connection terminal 2 for data PLL			
88	RC	I	A	Data PLL	VCO gain setting terminal for data PLL.			
89	AVSS	P		VDD & GND	Analog Ground.			
90	AVSS	P		VDD & GND	Analog Ground.			
91	AD0	I	A	ADC	AD0 Input.			
92	AD1	I	A	ADC	AD1 Input.			
93	AD2	I	A	ADC	AD2 Input.			
94	AVDD33	P		VDD & GND	Analog 3.3V Power.			
95	AD3	I	A	ADC	AD3 Input.			
96	AD4	I	A	ADC	AD4 Input.			
97	AD5	I	A	ADC	AD5 Input.			
98	AD6	I	A	ADC	AD6 Input.			
99	AD7	I	A	ADC	AD7 Input.			
100	AD8	I	A	ADC	AD8 Input.			
101	AD9	I	A	ADC	AD9 Input.			

IC502: CXD1885Q

No.	Terminal Name	I/O	A/D	Classification	Function	PU	PD	SMT
102	VREFH	I/O	A	ADC	Max Reference Voltage input for ADC. (Internal Reference Voltage mode, it will be an output state)			
103	VREFL	I/O	A	ADC	Min Reference Voltage input for ADC. (Internal Reference Voltage mode, it will be an output state)			
104	AVDD18	P		VDD & GND	Analog 1.8V Power.			
105	AVDD33	P		VDD & GND	Analog 3.3V Power.			
106	DA0 (TSCON)	O	A	DAC	DA0 output. (Track Servo output)			
107	DA1 (SLED)	O	A	DAC	DA1 output. (Sled Servo output)			
108	DA2 (FSCON)	O	A	DAC	DA2 output. (Focus Servo output)			
109	DA3 (SLED2_TILT)	O	A	DAC	DA3 output. (Sled Servo / Tilt Servo output)			
110	AVSS	P		VDD & GND	Analog Ground			
111	FG	I	D	SPM	FG signal input.			*
112	SPWM1	O	D	SPM	Spindle motor PWM output 1.			
113	SPWM2	O	D	SPM	Spindle motor PWM output 2.			
114	GPWM0	O	D	General PWM	Multi-purpose PWM output 0.			
115	GPWM1	O	D	General PWM	Multi-purpose PWM output 1.			
116	GPWM2	O	D	General PWM	Multi-purpose PWM output 2.			
117	GPWM3	O	D	General PWM	Multi-purpose PWM output 3.			
118	GPWM4	O	D	General PWM	Multi-purpose PWM output 4.			
119	GPWM5	O	D	General PWM	Multi-purpose PWM output 5.			
120	XLCAS	O	D	DRAM I/F	DRAM LCAS output. (Low-Byte row address strobe output)			
121	XUCAS	O	D	DRAM I/F	DRAM UCAS output. (Upper-Byte row address strobe output)			
122	XMOE	O	D	DRAM I/F	DRAM output enable.			
123	RA11	O	D	DRAM I/F	DRAM address output terminal 11.			
124	RA10	O	D	DRAM I/F	DRAM address output terminal 10.			
125	DVSS	P		VDD & GND	Digital Ground.			
126	RA9	O	D	DRAM I/F	DRAM address output terminal 9.			
127	RA8	O	D	DRAM I/F	DRAM address output terminal 8.			
128	RA7	O	D	DRAM I/F	DRAM address output terminal 7.			
129	RA6	O	D	DRAM I/F	DRAM address output terminal 6.			
130	RA5	O	D	DRAM I/F	DRAM address output terminal 5.			
131	DVDD33	P		VDD & GND	Digital 3.3V Power. (for I/O)			
132	RA4	O	D	DRAM I/F	DRAM address output terminal 4.			
133	RA3	O	D	DRAM I/F	DRAM address output terminal 3.			
134	RA2	O	D	DRAM I/F	DRAM address output terminal 2.			
135	RA1	O	D	DRAM I/F	DRAM address output terminal 1.			
136	DVDD18	P		VDD & GND	Digital 1.8V Power. (for Internal Logic power)			
137	RA0	O	D	DRAM I/F	DRAM address output terminal 0.			
138	XRAS	O	D	DRAM I/F	DRAM RAS output. (Column address strobe output)			
139	XMWR	O	D	DRAM I/F	DRAM Write enable.			
140	RD7	I/O	D	DRAM I/F	DRAM data input/output terminal 7.	*		
141	RD6	I/O	D	DRAM I/F	DRAM data input/output terminal 6.	*		
142	DVSS	P		VDD & GND	Digital Ground.			
143	RD5	I/O	D	DRAM I/F	DRAM data input/output terminal 5.	*		
144	RD4	I/O	D	DRAM I/F	DRAM data input/output terminal 4.	*		
145	RD3	I/O	D	DRAM I/F	DRAM data input/output terminal 3.	*		
146	RD2	I/O	D	DRAM I/F	DRAM data input/output terminal 2.	*		
147	RD1	I/O	D	DRAM I/F	DRAM data input/output terminal 1.	*		
148	RD0	I/O	D	DRAM I/F	DRAM data input/output terminal 0.	*		
149	RD15	I/O	D	DRAM I/F	DRAM data input/output terminal 15.	*		
150	RD14	I/O	D	DRAM I/F	DRAM data input/output terminal 14.	*		
151	RD13	I/O	D	DRAM I/F	DRAM data input/output terminal 13.	*		
152	RD12	I/O	D	DRAM I/F	DRAM data input/output terminal 12.	*		
153	RD11	I/O	D	DRAM I/F	DRAM data input/output terminal 11.	*		
154	RD10	I/O	D	DRAM I/F	DRAM data input/output terminal 10.	*		
155	RD9	I/O	D	DRAM I/F	DRAM data input/output terminal 9.	*		
156	DVDD18	P		VDD & GND	Digital 1.8V Power. (for internal Logic system)			
157	DVDD33	P		VDD & GND	Digital 3.3V power for I/O.			
158	RD8	I/O	D	DRAM I/F	DRAM data input/output terminal 8.	*		
159	TEST0	O	D	TEST/Monitor	TEST I/O 0.			
160	TEST1	O	D	TEST/Monitor	TEST I/O 1.			
161	TEST2	O	D	TEST/Monitor	TEST I/O 2.			
162	TEST3	O	D	TEST/Monitor	TEST I/O 3.			
163	TEST4	O	D	TEST/Monitor	TEST I/O 4.			

IC502: CXD1885Q

No.	Terminal Name	I/O	A/D	Classification	Function	PU	PD	SMT
164	TEST5	O	D	TEST/Monitor	TEST I/O 5.			
165	TEST6	O	D	TEST/Monitor	TEST I/O 6.			
166	TEST7	O	D	TEST/Monitor	TEST I/O 7.			
167	TEST8	O	D	TEST/Monitor	TEST I/O 8.			
168	TEST9	O	D	TEST/Monitor	TEST I/O 9.			
169	TEST10	O	D	TEST/Monitor	TEST I/O 10.			
170	TEST11	O	D	TEST/Monitor	TEST I/O 11.			
171	TEST12	O	D	TEST/Monitor	TEST I/O 12.			
172	TEST13	O	D	TEST/Monitor	TEST I/O 13.			
173	TEST14	O	D	TEST/Monitor	TEST I/O 14.			
174	TEST15	O	D	TEST/Monitor	TEST I/O 15.			
175	MODSEL0	I	D	TEST/Monitor	TEST mode select 0. (GND, under normal conditions)			
176	MODSEL1	I	D	TEST/Monitor	TEST mode select 1. (GND, under normal conditions)			
177	DVSS	P		VDD & GND	Digital Ground.			
178	MODSEL2	I	D	TEST/Monitor	TEST mode select 2. (GND, under normal conditions)			
179	GIO0	I/O	D	Multi-purpose	Multi-purpose port 0.		*	*
180	GIO1	I/O	D	Multi-purpose	Multi-purpose port 1.		*	*
181	GIO2	I/O	D	Multi-purpose	Multi-purpose port 2.		*	*
182	GIO3	I/O	D	Multi-purpose	Multi-purpose port 3.		*	*
183	DVDD33	P		VDD & GND	Digital 3.3V Power for I/O.			
184	GIO4	I/O	D	General Port	Multi-purpose port 4.		*	*
185	GIO5	I/O	D	General Port	Multi-purpose port 5.		*	*
186	GIO6	I/O	D	General Port	Multi-purpose port 6.		*	*
187	GIO7	I/O	D	General Port	Multi-purpose port 7.		*	*
188	DVDD18	P		VDD & GND	Digital 1.8V Power for I/O. (for internal Logic system)			
189	GIO8	I/O	D	General Port	Multi-purpose port 8.		*	*
190	GIO9	I/O	D	General Port	Multi-purpose port 9.	*	*	*
191	GIO10	I/O	D	General Port	Multi-purpose port 10.		*	*
192	GIO11	I/O	D	General Port	Multi-purpose port 11.		*	*
193	GIO12	I/O	D	General Port	Multi-purpose port 12.	*	*	*
194	DVSS	P		VDD & GND	Digital Ground.			
195	GIO13	I/O	D	Multi-purpose	Multi-purpose port 13.	*	*	*
196	GIO14	I/O	D	General Port	Multi-purpose port 14.	*	*	*
197	GIO15	I/O	D	General Port	Multi-purpose port 15.	*	*	*
198	GIO16	I/O	D	General Port	Multi-purpose port 16.		*	*
199	GIO17	I/O	D	General Port	Multi-purpose port 17.		*	*
200	GIO18	I/O	D	General Port	Multi-purpose port 18.		*	*
201	GIO19	I/O	D	General Port	Multi-purpose port 19.		*	*
202	TRST	I	D	JTAG I/F	JTAG Reset input.		*	*
203	TMS	I	D	JTAG I/F	JTAG Mode Select input.	*		*
204	TDI	I	D	JTAG I/F	JTAG Data Input.	*		*
205	TCK	I	D	JTAG I/F	JTAG Clock input.	*		
206	TDO	O	D	JTAG I/F	JTAG Data output.			
207	VMCHG	I	D	MCU I/F	VSTEM / external MCU access selection terminal of system setting register for DSP. (L: VSTEM, H: external MCU)			
208	DVDD18	P		VDD & GND	Digital 1.8V power for internal Logic system.			

IC503: M11L16161SA-45T

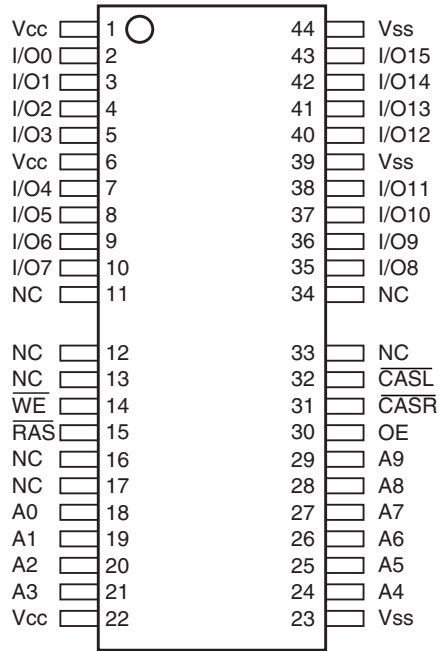

PIN DESCRIPTIONS

PIN NO. (SOJ Package)	PIN NAME	TYPE	DESCRIPTION
17~20,23~28	A0~A9	Input	Address Input Row Address:A0~A9 Column Address:A0~A9
14	$\overline{\text{RAS}}$	Input	Row Address Strobe
30	$\overline{\text{CASH}}$	Input	Column Address Strobe/Upper Byte Control
31	$\overline{\text{CASL}}$	Input	Column Address Strobe/Lower Byte Control
13	$\overline{\text{WE}}$	Input	Write Enable
29	$\overline{\text{OE}}$	Input	Output Enable
2~5,7~10, 33~36,38~41	I/O0~I/O15	Input/Output	Data Input/Output
1,6,21	Vcc	Supply	Power,(5V or 3.3V)
22,37,42	Vss	Ground	Ground
11,12,15,16,32	NC	-	No Connect

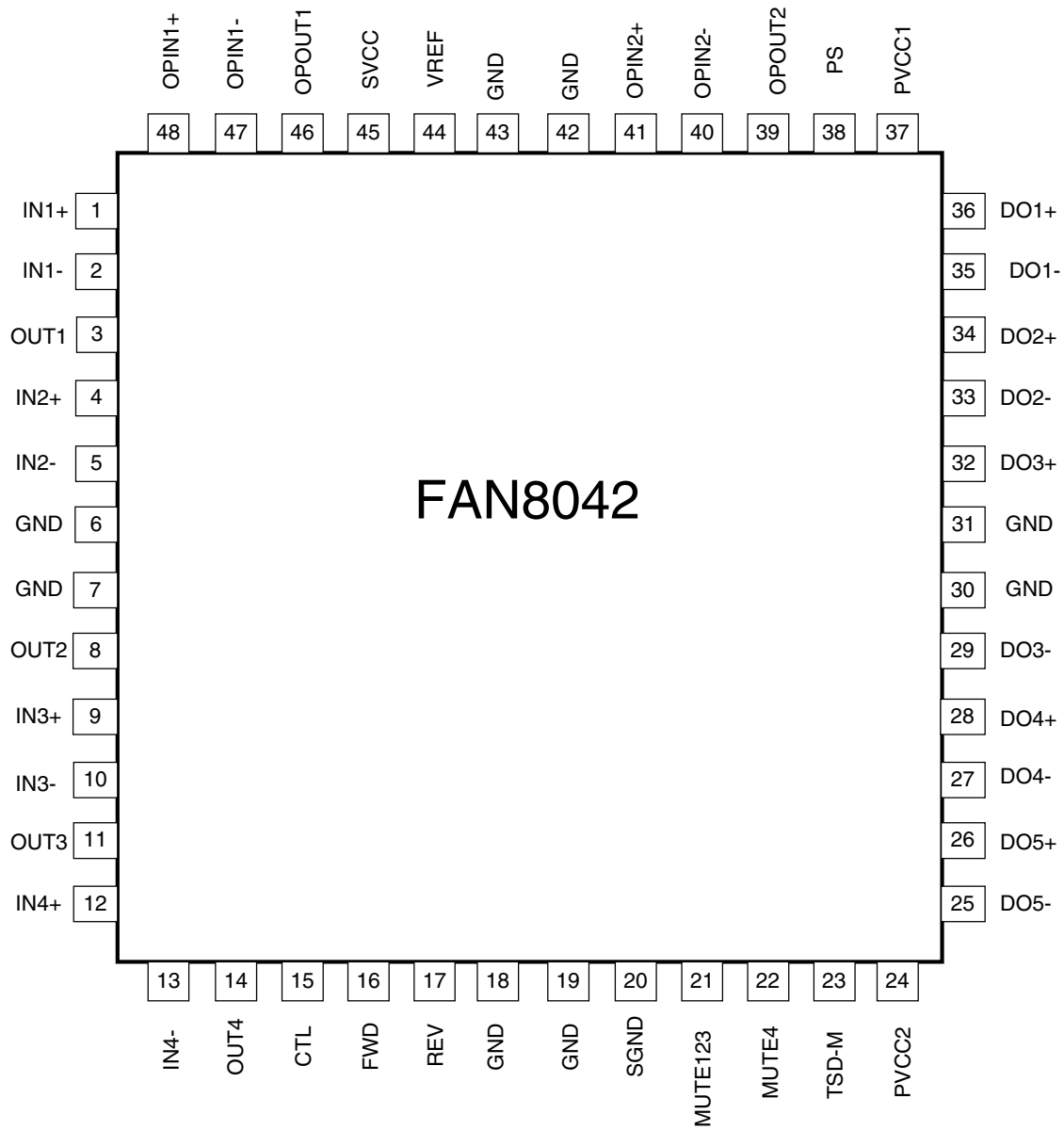

IC508: FAN8042

No.	Pin Name	I/O	Pin Function Description
1	IN1+	I	CH1 op-amp input (+)
2	IN1-	I	CH1 op-amp input (-)
3	OUT1	O	CH1 op-amp output
4	IN2+	I	CH2 op-amp input (+)
5	IN2-	I	CH2 op-amp input (-)
6	GND	-	Ground
7	GND	-	Ground
8	OUT2	O	CH2 op-amp output
9	IN3+	I	CH3 op-amp input (+)
10	IN3-	I	CH3 op-amp input (-)
11	OUT3	O	CH3 op-amp output
12	IN4+	I	CH4 op-amp input (+)
13	IN4-	I	CH4 op-amp input (-)
14	OUT4	O	CH4 op-amp output
15	CTL	I	CH5 motor speed control
16	FWD	I	CH5 forward input
17	REV	I	CH5 reverse input
18	GND	-	Ground
19	GND	-	Ground
20	SGND	-	Signal Ground
21	MUTE123	I	Mute for CH1,2,3
22	MUTE4	I	Mute for CH4
23	TSD-M	O	TSD monitor
24	PVCC2	-	Power supply voltage 2 (For CH4,CH5)
25	DO5-	O	CH5 drive output (-)
26	DO5+	O	CH5 drive output (+)
27	DO4-	O	CH4 drive output (-)
28	DO4+	O	CH4 drive output (+)
29	DO3-	O	CH3 drive output (-)
30	GND	-	Ground
31	GND	-	Ground
32	DO3+	O	CH3 drive output (+)
33	DO2-	O	CH2 drive output (-)
34	DO2+	O	CH2 drive output (+)
35	DO1-	O	CH1 drive output (-)
36	DO1+	O	CH1 drive output (+)
37	PVCC1	-	Power supply voltage 1 (FOR CH1 CH2,CH3)
38	PS	I	Power save
39	OPOUT2	O	Normal op-amp2 output
40	OPIN2-	I	Normal op-amp2 input (-)
41	OPIN2+	I	Normal op-amp2 input (+)
42	GND	-	Ground
43	GND	-	Ground
44	VREF	I	Bias voltage input
45	SVCC	-	Signal & OPAMPs supply voltage
46	OPOUT1	O	Normal op-amp1 output
47	OPIN1-	I	Normal op-amp1 input (-)
48	OPIN1+	I	Normal op-amp1 input (+)

IC508: FAN8042

Internal Block Diagram

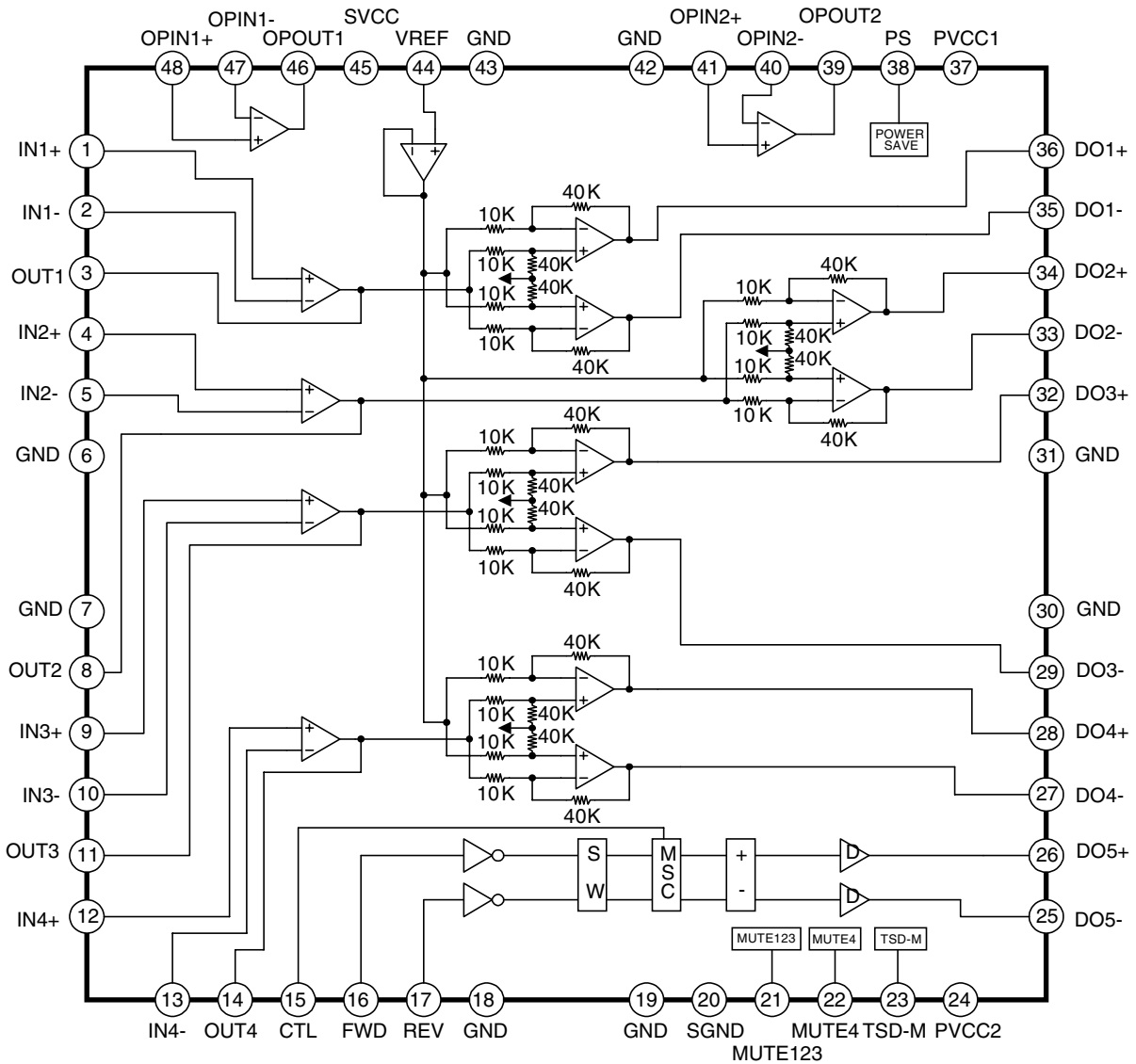

Note. Detailed circuit of the output power amp

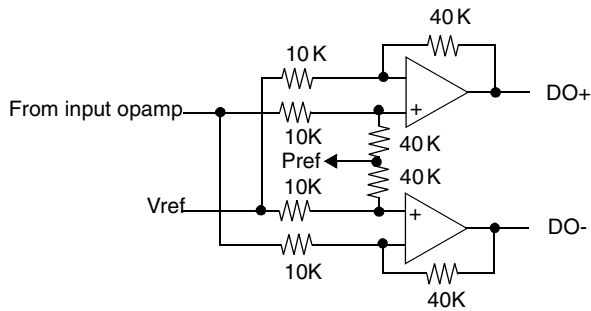

Pref1 is almost $PVCC1 / 2$
 Pref2 is almost $PVCC2 / 2$

IC731: M30624FGNGP

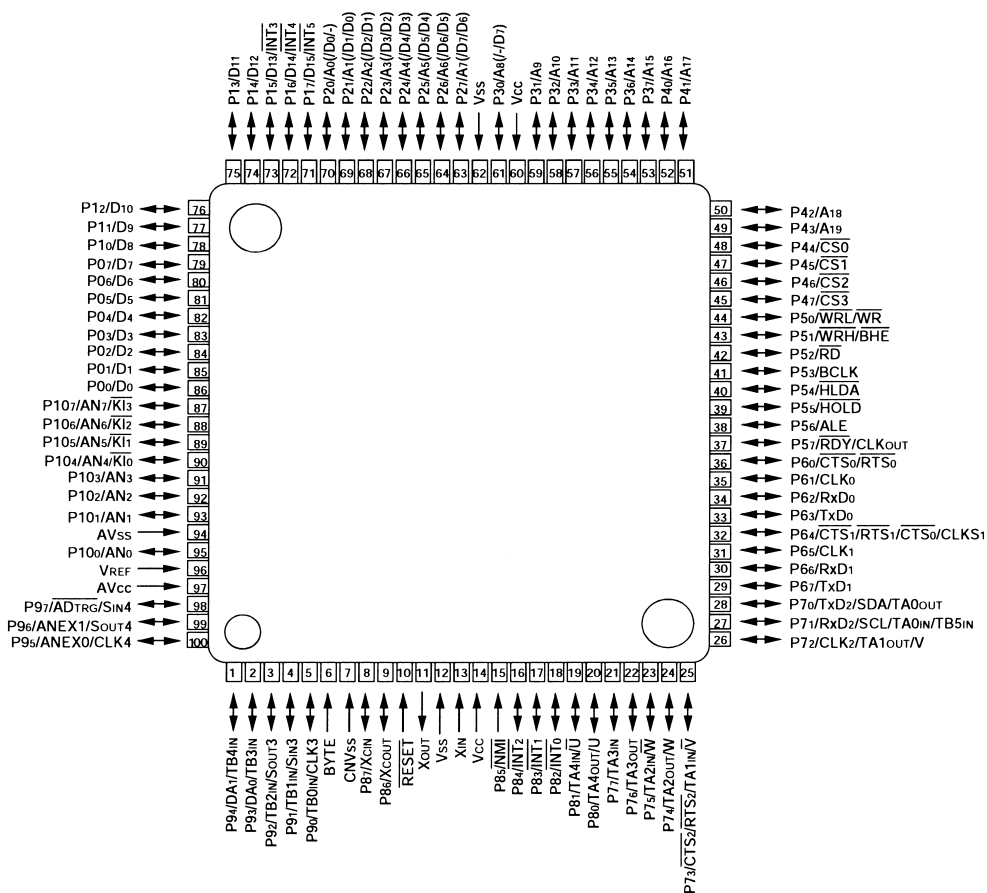

No.	Pin Port	Function	I/O	Initial	Mode	Action	Note	Description (USER1:H/USER2:H)
1	P94/DA1/TB4IN	P94	O	H	MULT_LED	MULTI SURROUND(LED L=ON)		
2	P93/DA0/TB3IN	P93	O	H	DSCS1	CHIP SELECT for FRONT DAC		
3	P92/TB2IN/SOUT3	SOUT3	O	H	DSDO	CONTOROL SERIAL DATA for ALL DAC		CS4379 control data
4	P91/TB1IN/SIN3	P91	I		USER1	MODEL SELECT 1		H
5	P90/TB0IN/CLK3	CLK3	O	H	DSCLK	DATA CLOCK for ALL DAC		CS4379 control data clock
6	BYTE	BYTE	I		BYTE	PULL UP(8bit)		
7	CNVss	CNVss	I		CNVSS	PULL DOWN 5.6k ohm)		
8	P87/XCIN	P87	O	H	DSCS2	CHIP SELECT for SURROUND DAC		CS4379 SURROUND ch chip select
9	P86/XCOUT	P86	O	H	DSCS3	CHIP SELECT for DXP7001 DAC or DISPLAY OFF		DISPLAY OFF=LOW
10	RESET~	RESET~	I		RESET	RESET INPUT		
11	XOUT	XOUT	O		X.TAL	OSC OUT		
12	VSS	VSS	-		VSS	GND		
13	XIN	XIN	I		X.TAL	OSC IN		
14	VCC	VCC	-		3.3V	POWER INPUT		
15	P85/NMI~	P85	I		P_UP1	10K PULL UP(NON CONECT)	NOT USE	
16	P84/INT2~	INT2~	I/O		IR_IN	IR INPUT SIGNAL(Ma:RC-5/ De:SHARP FORMAT)		IR remote control input
17	P83/INT1~	INT1~	I		MINT	INT from CXD1885Q		
18	P82/INT0~	INT0~	I		DRVIRQ	CXD1885Q DATA REQUEST		

IC731: M30624FGNGP

No.	Pin Port	Function	I/O	Initial	Mode	Action	Note	Description (USER1:H/USER2:H)
19	P81/TA4IN/U~	P81	O	L	FS_SW	DAC SYSTEM F78CLK SWITCH SIGNAL(384fs/192fs)		CD:Fix to Low SACD:Fix to High
20	P80/TA4OUT/U	TA4OUT	O	L	PWM	TRAY CONTROL PWM SIGNAL		
21	P77/TA3IN	P77	O	H	SELDS	SELECT for DSD SIGNAL(PLD)		
22	P76/TA3OUT	P76	O	H	SMUTE	MUTING for CXD2753R		
23	P75/TA2IN/W~	P75	O	H	DSDRST	RESET for CXD2753R		
24	P74/TA2OUT/W	P74	I		MSREADY	SERIAL DATA READY from CXD2753R		
25	P73/CTS2~/RTS2~/TA1IN/V~	P73	O	H	XMSLAT	SERIAL DATA LATCH for CXD2753R		
26	P72/CLK2/TA1OUT/V	CLK2	O	H	MSCK	SERIAL DATA CLK for CXD2753R		
27	P71/RXD2/SCL/TA0IN/TB5IN	RXD2	I		MSDATAO	SERIAL DATA INPUT from CXD2753R	PULL UP	
28	P70/TXD2/SDA/TA0OUT	TXD2	O	H	MSDATI	SERIAL DATA OUTPUT for CXD2753R	PULL UP	
29	P67/TXD1	P67	O	H	CD_LED	FOR CD SELECT (LED L:ON)	Flash(w:pull up)	
30	P66/RXD1	P66	O	H	SA_LED	FOR SACD SELECT (LED L:ON)	Flash(w:pull up)	
31	P65/CLK1	P65	O	H	PULL_DWN	5.1K PULL DOWN(NON CONECT)	Flash(w:pull down)	
32	P64/CTS1~/RTS1~/CTS0~/CLKS1	P64	O	H	DRVRST	RESET for CXD1885Q(RESET=L)	Flash(w:pull up)	
33	P63/TXD0	TXD0	O	H	DRVRX	SERIAL DATA for CXD1885Q		
34	P62/RXD0	RXD0	I		DRVTX	SERIAL DATA from CXD1885Q		
35	P61/CLK0	CLK0	O	H	DRVCLK	DATA CLOCK for CXD1885Q		
36	P60/CTS0~/RTS0~	CTS0~	I		DRVRDY	DATA READY SIGNAL from CXD1885Q		
37	P57/RDY~/CLKOUT	RDY~	I		MRDY	READY from CXD1885Q		
38	P56/ALE	P56	I		OPEN1	OPEN(anytime)	Flash (w:pull up)	OPEN (anytime)
39	P55/HOLD~	P55	I		P_UP2	10K PULL UP(NON CONECT)	Flash (w:GND)	
40	P54/HLDA~	P54	-		OPEN2	OPEN		
41	P53/BCLK	P53	-		OPEN3	OPEN		
42	P52/RD~	RD~	O		MRD	READ STROBE for XD1885Q		
43	P51/WRH~/BHE~	P51	-		OPEN4	OPEN		
44	P50/WRL~/WR~	WR~	O		MWR	WRITE STROBE for XD1885Q	Flash(w:pull up)	
45	P47/CS3~	CS3~	O	H	MCS	CHIP SELECT for CXD1885Q		
46	P46/CS2~	CS2~	O	H	MCS2	CHIP SELECT for 1M-SRAM		
47	P45/CS1~	P45	O	H	OPN_DRV	TRAY OPEN DRIVE CONTROL		
48	P44/CS0~	P44	O	H	CLS_DRV	TRAY CLOSE DRIVE CONTROL		
49	P43/A19	P43	O		OPEN4	OPEN		
50	P42/A18	P42	O		OPEN5	OPEN		
51	P41/A17	P41	O		OPEN5	OPEN		
52	P40/A16	A16	O		A16	ADRRES LINE		
53	P37/A15	A15	O		A15	ADRRES LINE		
54	P36/A14	A14	O		A14	ADRRES LINE		
55	P35/A13	A13	O		A13	ADRRES LINE		
56	P34/A12	A12	O		A12	ADRRES LINE		
57	P33/A11	A11	O		A11	ADRRES LINE		
58	P32/A10	A10	O		A10	ADRRES LINE		
59	P31/A9	A9	O		A9	ADRRES LINE		
60	VCC	VCC	-	---		3.3V		
61	P30/A8(/D7)	A8	O		A8	ADRRES LINE		
62	VSS	VSS	-	---		GND		
63	P27/A7(/D7/D6)	A7	O		A7	ADRRES LINE		
64	P26/A6(/D6/D5)	A6	O		A6	ADRRES LINE		
65	P25/A5(/D5/D4)	A5	O		A5	ADRRES LINE		
66	P24/A4(/D4/D3)	A4	O		A4	ADRRES LINE		
67	P23/A3(/D3/D2)	A3	O		A3	ADRRES LINE		
68	P22/A2(/D2/D1)	A2	O		A2	ADRRES LINE		
69	P21/A1(/D1/D0)	A1	O		A1	ADRRES LINE		

IC731: M30624FGNGP

No.	Pin Port	Function	I/O	Initial	Mode	Action	Note	Description (USER1:H/USER2:H)
70	P20/A0(/D0/?)	A0	O		A0	ADDRRES LINE		
71	P17/D15/INT5~	P17	O	H	ICLK	IIC CLK FOR EE_ROM(AT24C04N)		
72	P16/D14/INT4~	P16	I/O	H	IDAT	IIC DATA FOR EE_ROM(AT24C04N)		
73	P15/D13/INT3~	P15	I		OPN_SW	TRAY OPEN DETECT SW		
74	P14/D12	P14	I		CLS_SW	TRAY CLOSE DETECT SW		
75	P13/D11	P13	O	H	PCMRST	DE:RESET for DXP7001 or Ma:DISPLAY LED(L:ON)	Flash(w:pull up)	RESET for DXP7001(reset=L)
76	P12/D10	P12	I		FILT1	SACD: DAC SYSTEM CLK SWITCHING CONTROL IN	(Low:384fs/ Hi:192fs)	for FILTER-SW
77	P11/D9	P11	O	H	MUT2	MUTING for MULTI CHANNEL(H:MUTE)	RELAY/TR	
78	P10/D8	P10	O	H	MUT1	MUTING for STEREO CHANNEL(H:MUTE)	RELAY/TR	
79	P07/D7	D7	I/O		D7	8bit DATA LINE		
80	P06/D6	D6	I/O		D6	8bit DATA LINE		
81	P05/D5	D5	I/O		D5	8bit DATA LINE		
82	P04/D4	D4	I/O		D4	8bit DATA LINE		
83	P03/D3	D3	I/O		D3	8bit DATA LINE		
84	P02/D2	D2	I/O		D2	8bit DATA LINE		
85	P01/D1	D1	I/O		D1	8bit DATA LINE		
86	P00/D0	D0	I/O		D0	8bit DATA LINE		
87	P107/AN7/KI3~	P107	O	H	MODE	CD/SACD SWITCHING SIGNAL(L:CD,SACD:H)		Switching of digital audio data for SACD and CD(L=CD, H=SACD) Data transwission hold to recognition of the next DISC
88	P106/AN6/KI2~	P106	O	L	FCS	DISPLAY CHIP SERECT for FL DRIVER		ML9207-01GP chip select
89	P105/AN5/KI1~	P105	O	H	DSRST2	DSP RESET2 for SURROUND CHANNEL or ATT		Mute signal fo Search
90	P104/AN4/KI0~	P104	O	H	DSRST1	DSP RESET1 for FRONT CHANNEL		RESET for DAC (reset=L)
91	P103/AN3	P103	O	L	FRRST	DISPLAY DRIVER RESET		ML9207-01GP reset
92	P102/AN2	AN2	I		KEY2	KEYS SENS		
93	P101/AN1	AN1	I		KEY1	KEYS SENS		
94	AVSS	AVSS	-		GND	AD GND		
95	P100/AN0	AN0	I		KEY0	KEYS SENS		
96	VRef	Vref	I		3.3V	AD reference		
97	AVcc	AVcc	-		3.3V	AD Vcc		
98	P97/ADTRG~/SIN4	P97	I		USER2	MODEL SELECT 2		H
99	P96/ANEX1/SOUT4	SOUT4	O	L	FDAT	DISPLAY DATA for FL DRIVER		ML9207-01GP control data
100	P95/ANEX0/CLK4	CLK4	O	L	FCLK	DISPLAY CLOCK for FL DRIVER		ML9207-01GP control clock

IC733: S-80843C

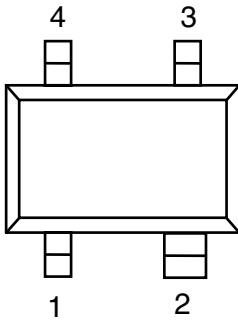

1	OUT
2	VDD
3	N.C.
4	VSS

IC734: TC74VHC74FT

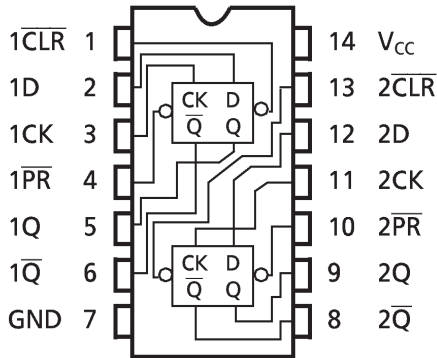

IC736: TC74VHC157FT

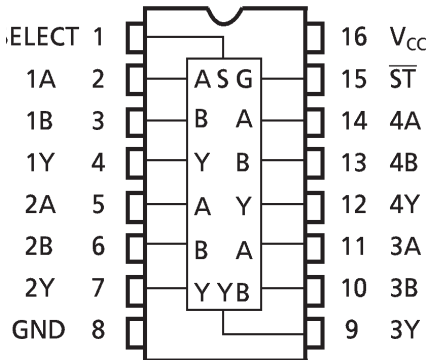

IC737: AT24C04

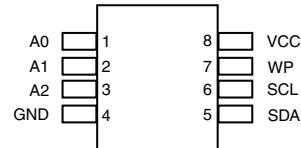

Pin Configurations

Pin Name	Function
A0 - A2	Address Inputs
SDA	Serial Data
SCL	Serial Clock Input
WP	Write Protect
NC	No Connect

TRANSISTORS

DTA114EK — PNP
DTC114EK — NPN

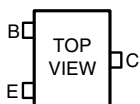

DTA Series

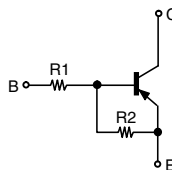

	R1	R2
DTA114EK	10kohm	10kohm

DTC Series

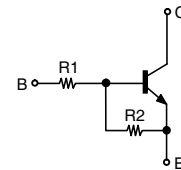

	R1	R2
DTC114EK	10kohm	10kohm

2. BLOCK DIAGRAM

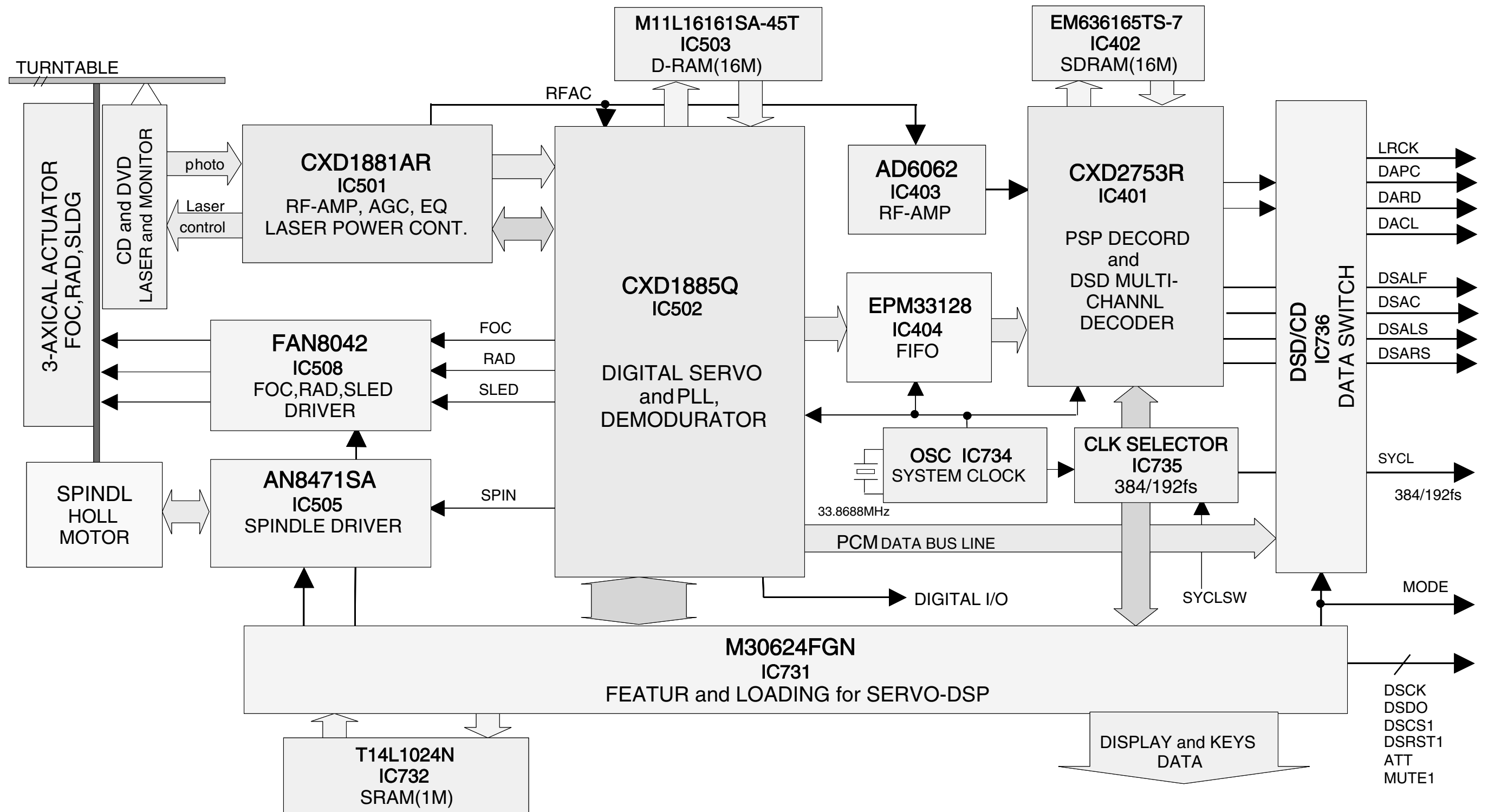

3. SCHEMATIC DIAGRAM

Super Audio CD MODULE UNIT - 1/6

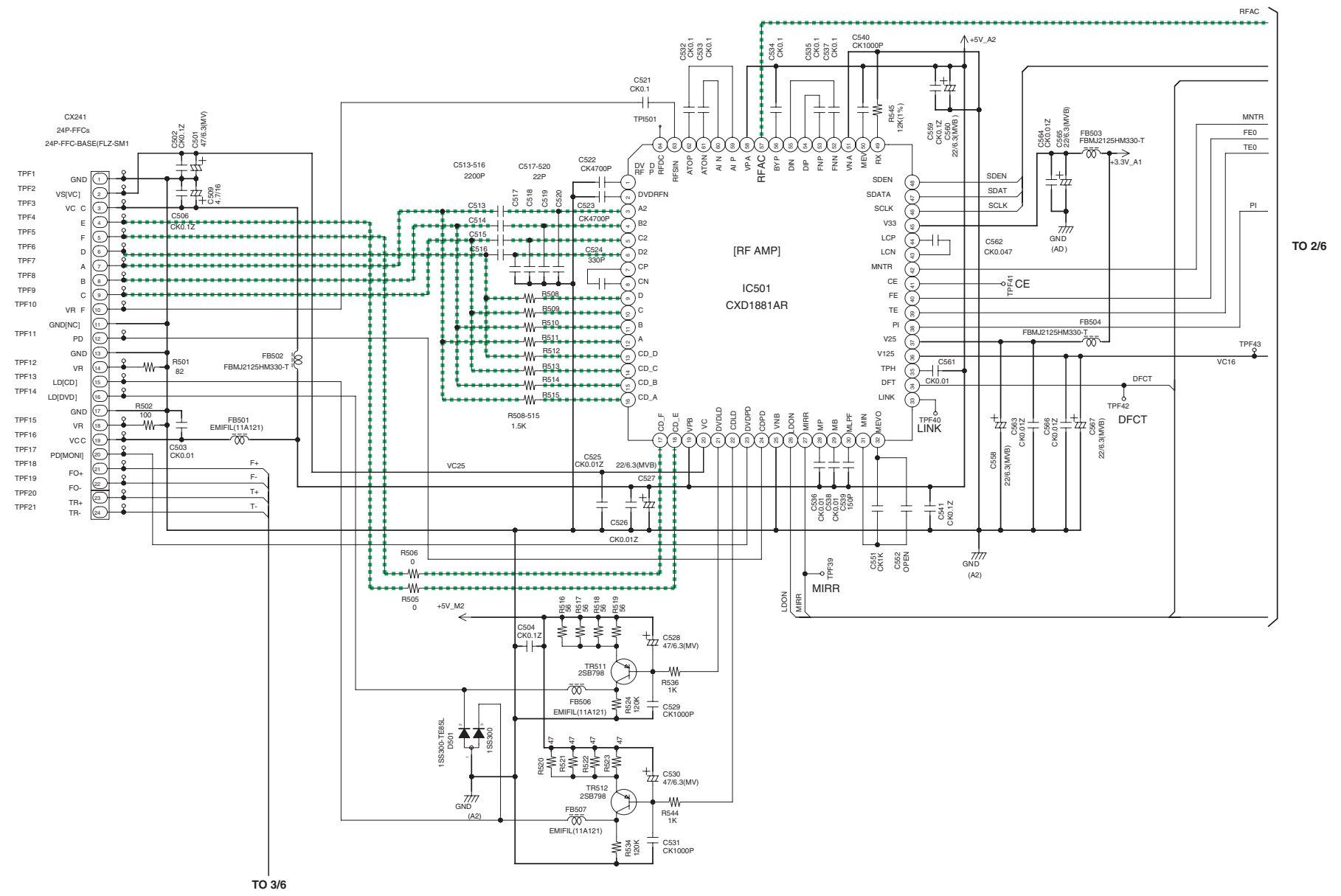

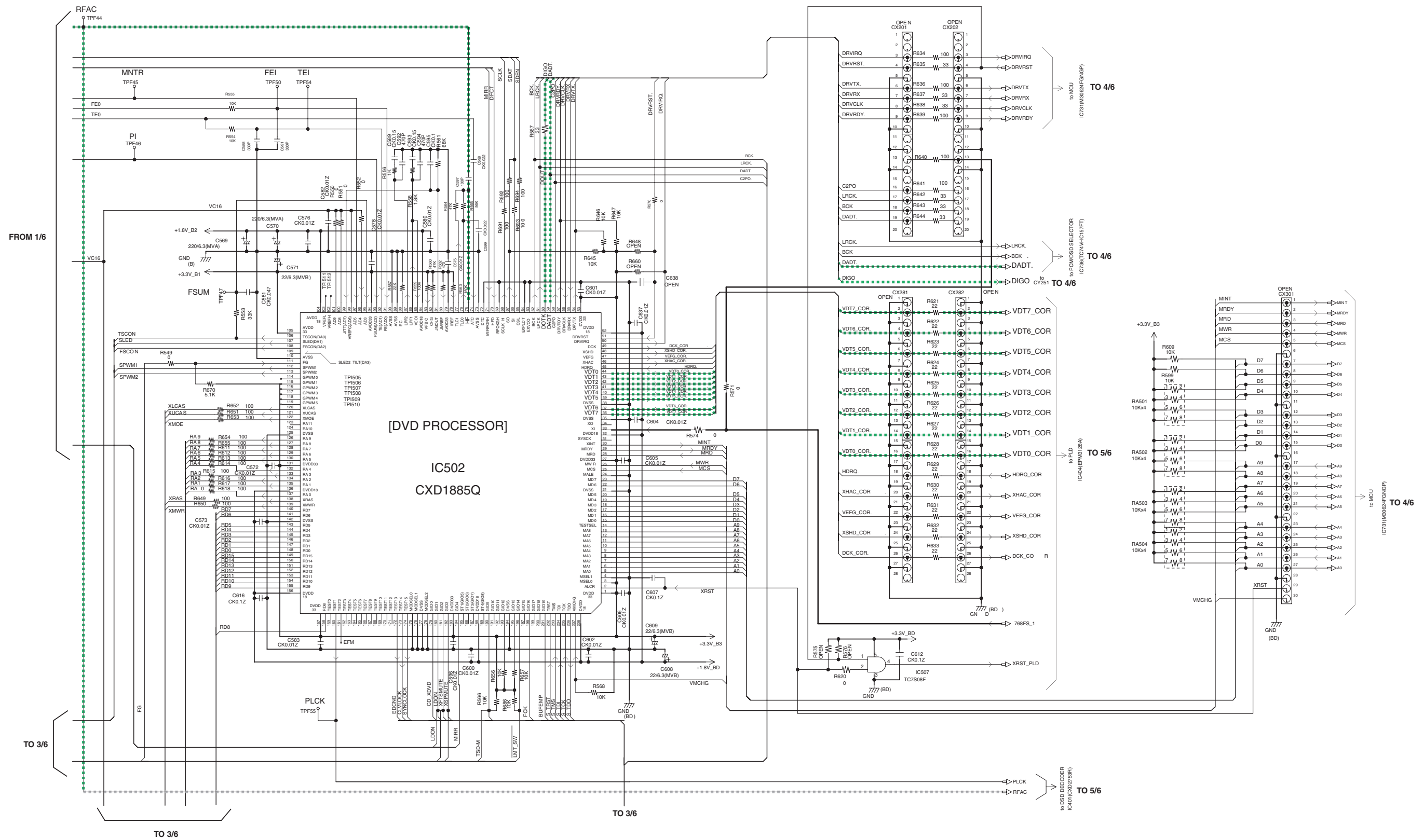

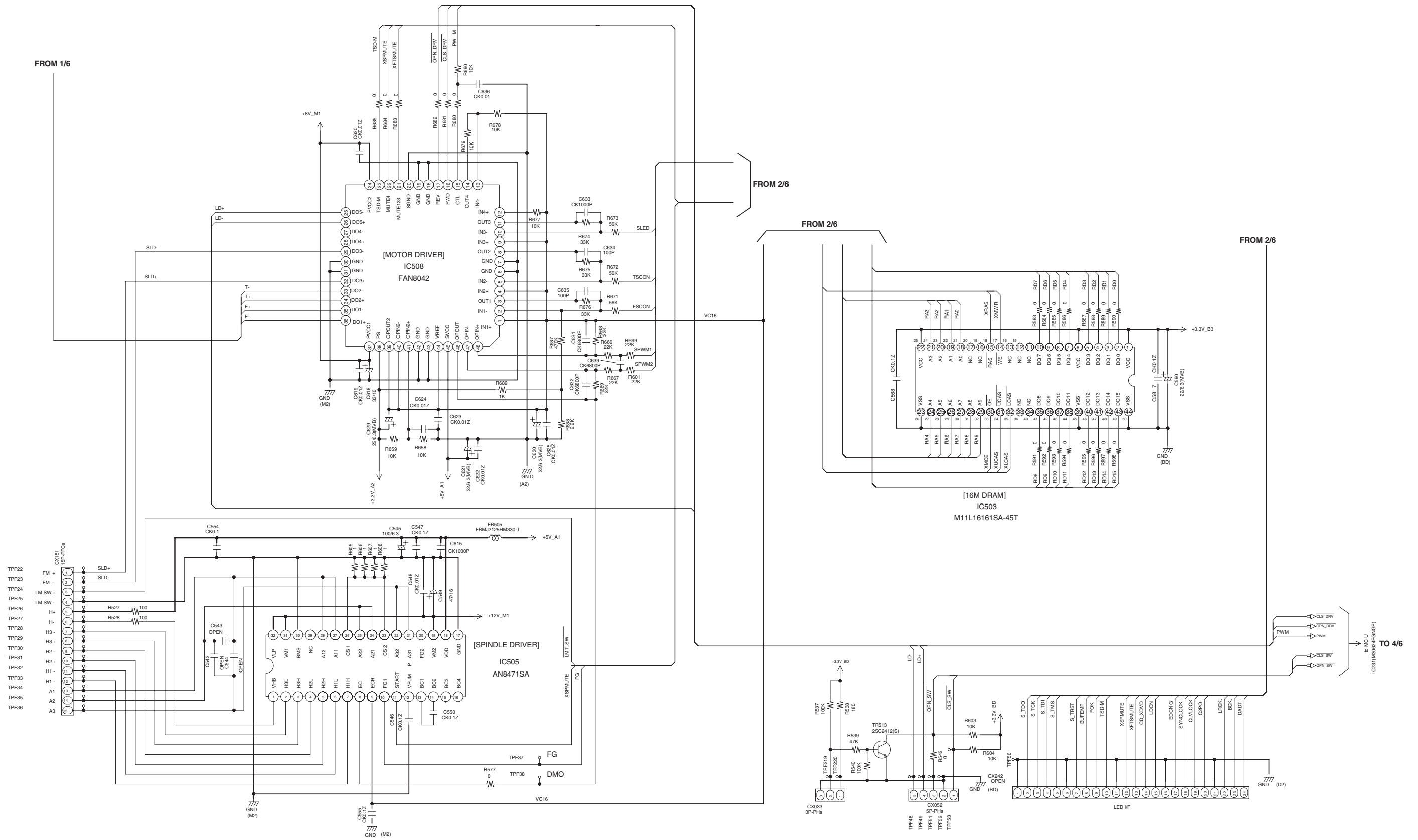

Super Audio CD MODULE UNIT - 4/6

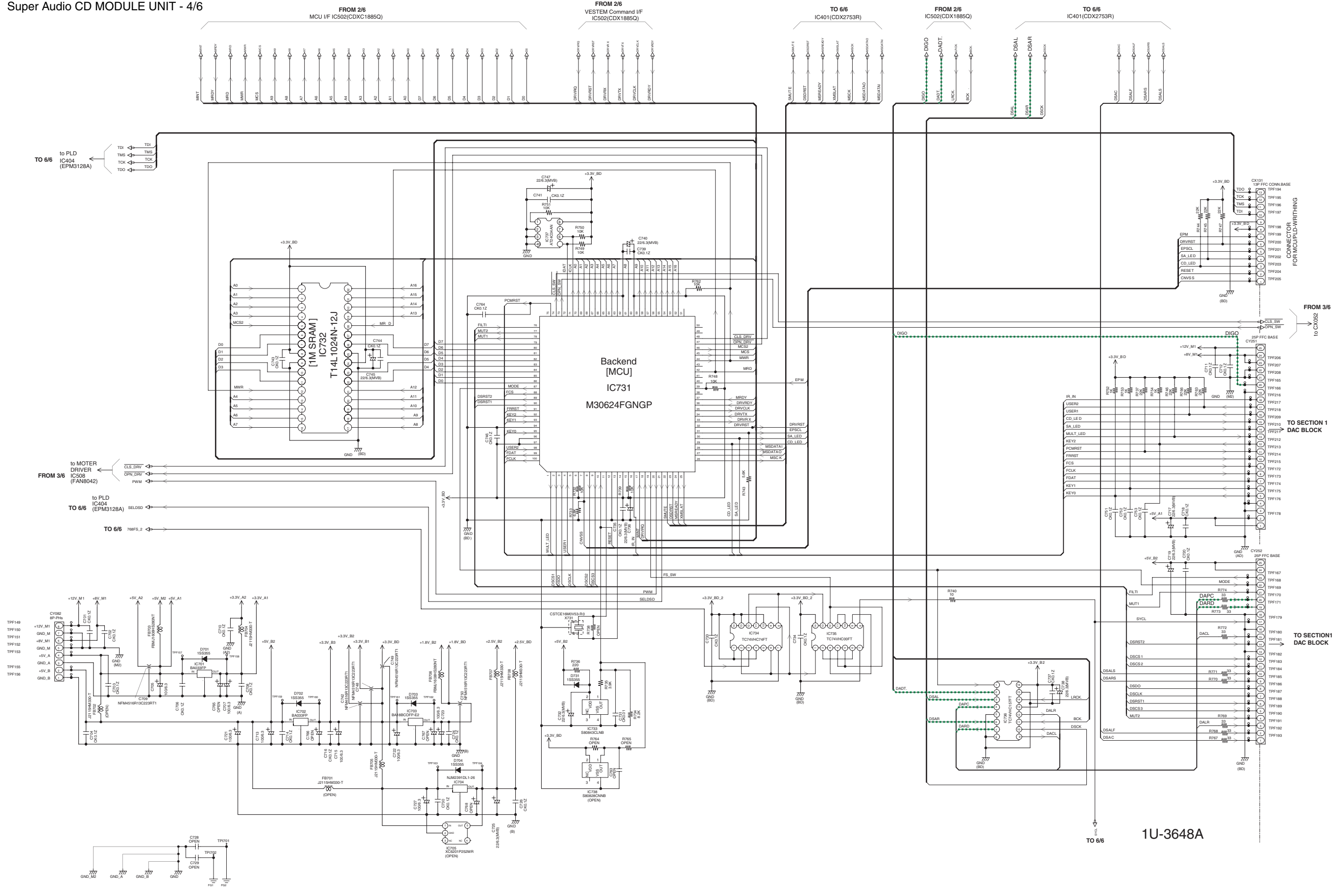

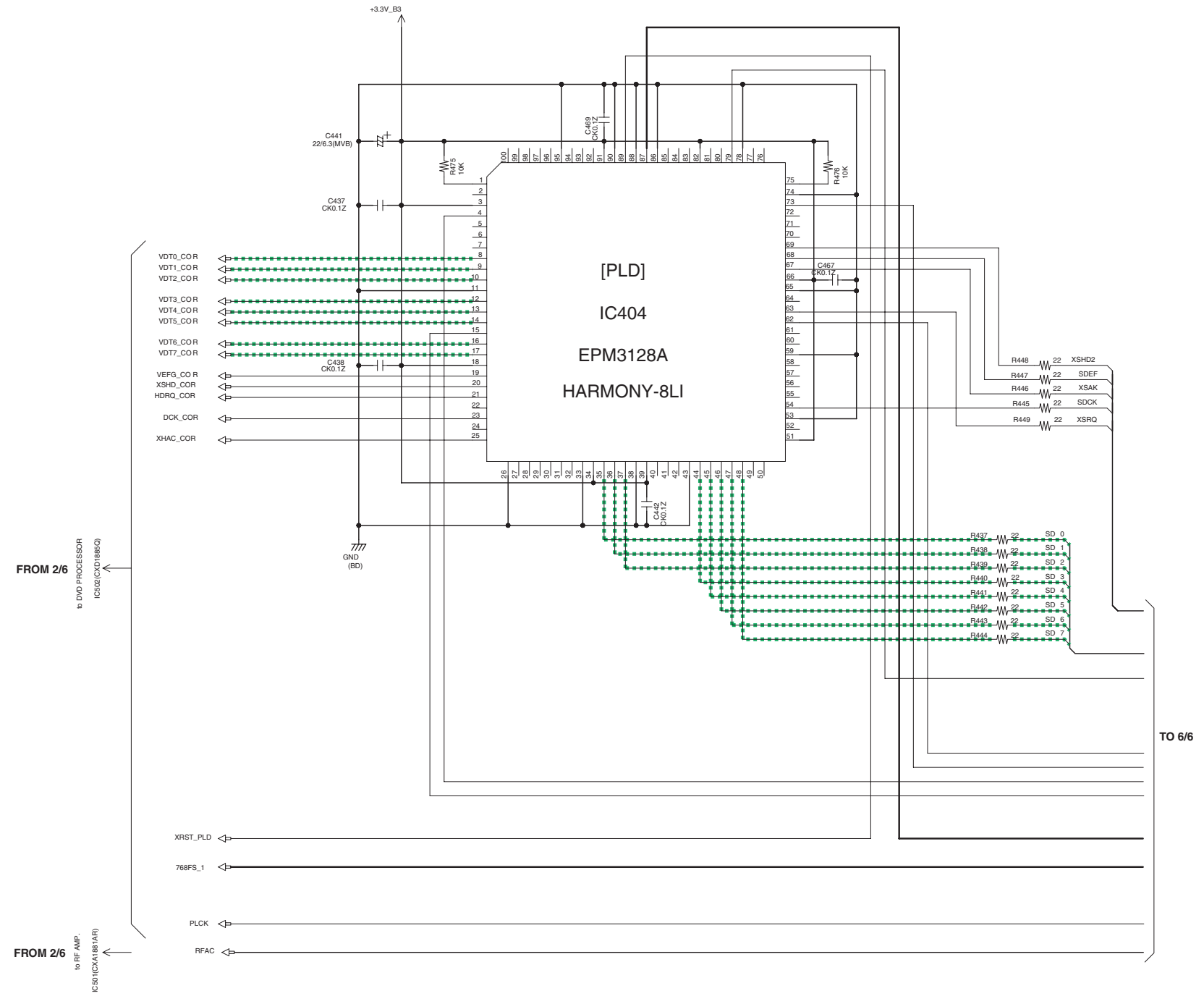

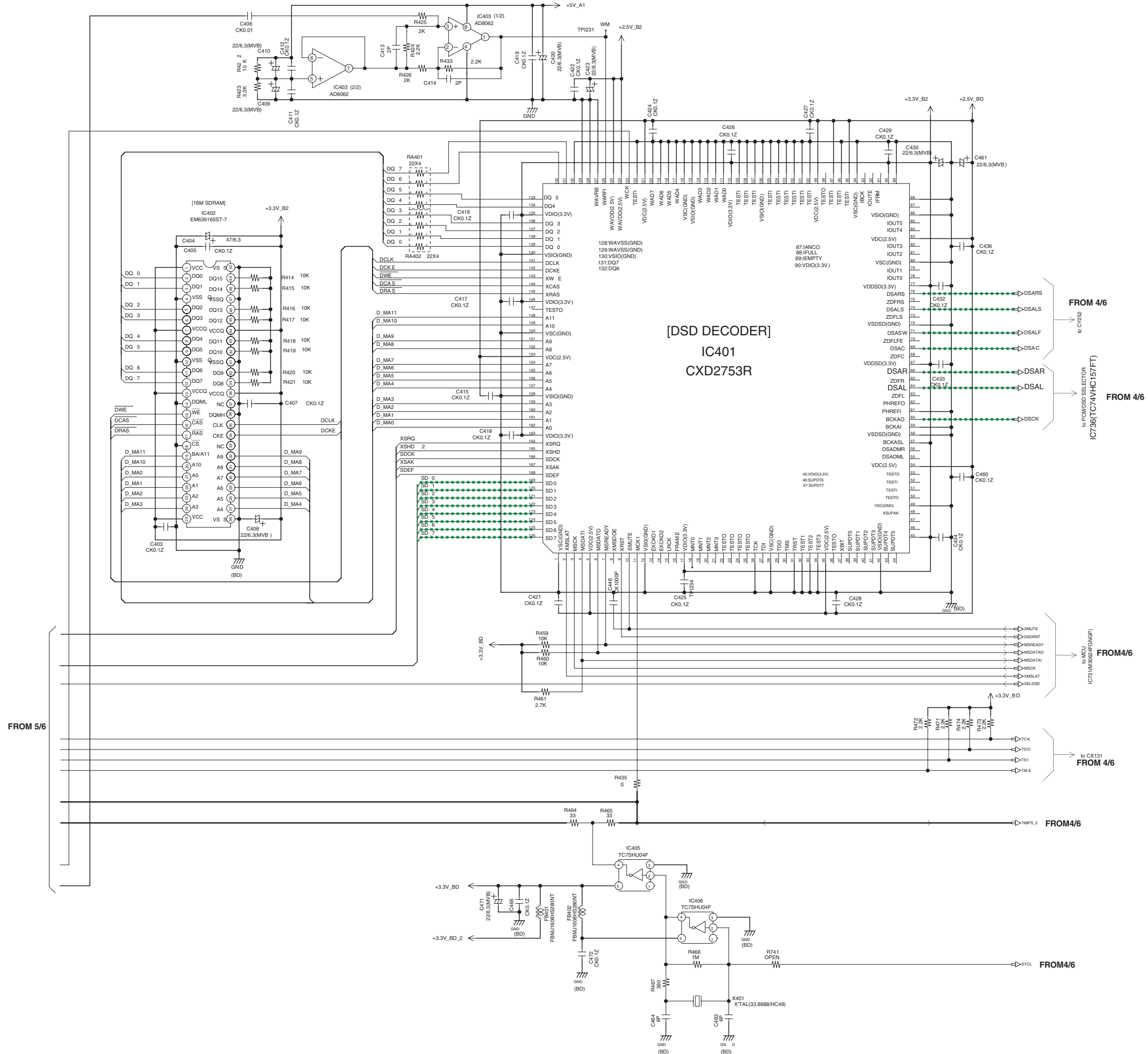

4. PARTS LOCATION

Super Audio CD MODULE UNIT

C406	G4	C624	E1	R505	E2	R624	C4
C413	F4	C631	D1	R506	E2	R625	C4
C414	G4	C632	D1	R508	F3	R626	C4
C415	F4	C633	D2	R509	F3	R627	C4
C416	F4	C634	D2	R510	E3	R628	C4
C417	F4	C635	D1	R511	F2	R629	D4
C418	E4	C639	D1	R512	E2	R630	D4
C419	G4	C701	H3	R513	F2	R631	D4
C424	F5	C702	H2	R514	E2	R632	D4
C425	E5	C703	H2	R515	E2	R633	D4
C426	F5	C704	H2	R516	E2	R634	A6
C427	F5	C709	F2	R517	E2	R635	A6
C428	E5	C726	G5	R518	F2	R636	A6
C429	F6	C728	H6	R519	F2	R637	A6
C432	F6	C729	H1	R520	E1	R638	A6
C433	E6	C730	G5	R521	F1	R639	A6
C434	E6	C731	G5	R522	F1	R640	A6
C437	D4	C735	B6	R523	F1	R641	A6
C438	D4	C741	C5	R524	F2	R642	A6
C446	E5	C742	G5	R528	C1	R643	A6
C460	E6	C743	C5	R534	F1	R644	A6
C463	D5	C744	B5	R536	E2	R646	A4
C464	D5	C748	D2	R537	A1	R649	C2
C465	D5	C749	G6	R538	A2	R650	B2
C467	D4	C763	C6	R539	A1	R656	B3
C502	F3	C765	G2	R540	A1	R657	B3
C503	F3	D501	F2	R542	A6	R658	E1
C504	F1	D731	G6	R544	E1	R659	E1
C506	F3	FB50	F2	R545	E3	R666	D1
C509	F3	FB50	F3	R549	C2	R667	D1
C513	F3	FB50	C1	R550	D2	R668	D1
C514	F3	FB50	F2	R551	D2	R669	D1
C515	F3	FB50	F1	R552	D3	R671	D1
C516	F3	FB70	F2	R553	C2	R672	D2
C521	E3	FB70	G5	R554	D3	R673	D2
C522	F3	FB70	G5	R555	D3	R674	D2
C523	F3	IC40	F5	R556	D3	R675	D2
C524	E3	IC40	G4	R558	D3	R676	D1
C525	E2	IC40	D5	R564	D3	R677	D2
C529	E2	IC50	E3	R565	D3	R678	D2
C531	F1	IC50	C3	R566	B3	R679	D2
C532	E3	IC50	B1	R567	D4	R686	B3
C533	E3	IC50	C5	R568	B4	R691	D3
C535	E3	IC50	E2	R574	C4	R692	D3
C537	E3	IC70	G5	R575	B4	R693	D4
C538	E2	IC73	B5	R576	D6	R694	D3
C539	E2	IC73	G6	R577	C1	R699	D1
C541	E2	IC73	C5	R583	B2	R732	B6
C546	B1	IC73	C6	R584	B2	R733	B6
C547	B2	R424	F4	R585	B2	R734	G5
C548	B2	R425	G4	R586	B2	R735	G6
C550	B1	R426	G4	R587	B2	R736	G6
C551	E2	R433	G4	R588	B2	R743	F6
C552	E2	R435	E5	R589	B2	R744	G6
C554	C1	R437	E4	R590	B2	R745	G6
C555	B1	R438	E4	R595	B2	R746	G6
C561	E2	R439	E4	R596	B2	R747	B6
C562	D3	R440	E4	R597	B2	R751	C5
C572	C2	R441	E4	R598	B2	R752	G6
C581	C2	R442	E4	R599	C4	R753	G6
C582	D3	R443	E4	R601	D1	R754	G6
C588	D3	R444	E4	R603	A6	R762	C5
C589	D3	R445	E4	R604	A6	R763	G6
C591	D3	R459	B6	R605	B2	R764	C5
C592	D3	R460	B6	R606	B2	R765	C6
C593	D3	R461	B6	R607	B2	R766	G6
C594	D3	R464	D5	R608	B2	R768	F6
C597	D3	R465	D5	R609	C4	R770	F6
C598	D3	R467	D5	R615	C2	RA50	B4
C599	D3	R471	F6	R616	C2	RA50	B4
C602	B4	R472	F6	R617	C2	TR51	F2
C607	B4	R473	F6	R618	C2	TR51	F1
C612	C5	R474	F6	R621	C4	TR51	A1
C615	B2	R501	F3	R622	C4		
C619	E1	R502	F3	R623	C4		

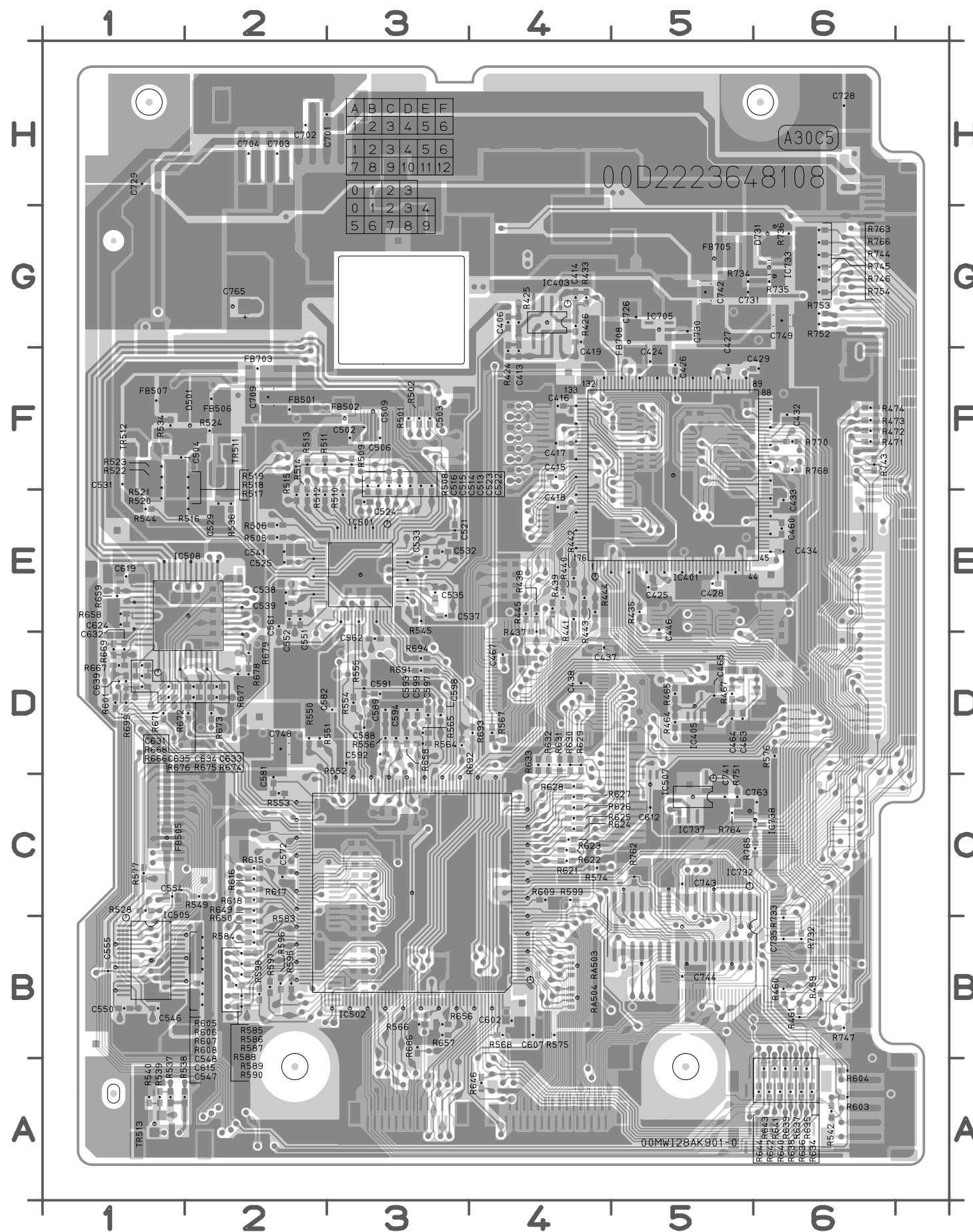

鉛フリー半田

半田付けには、鉛フリー半田 (Sn-Ag-Cu) を使用してください。

Lead-free Solder

When soldering, use the Lead-free Solder (Sn-Ag-Cu).

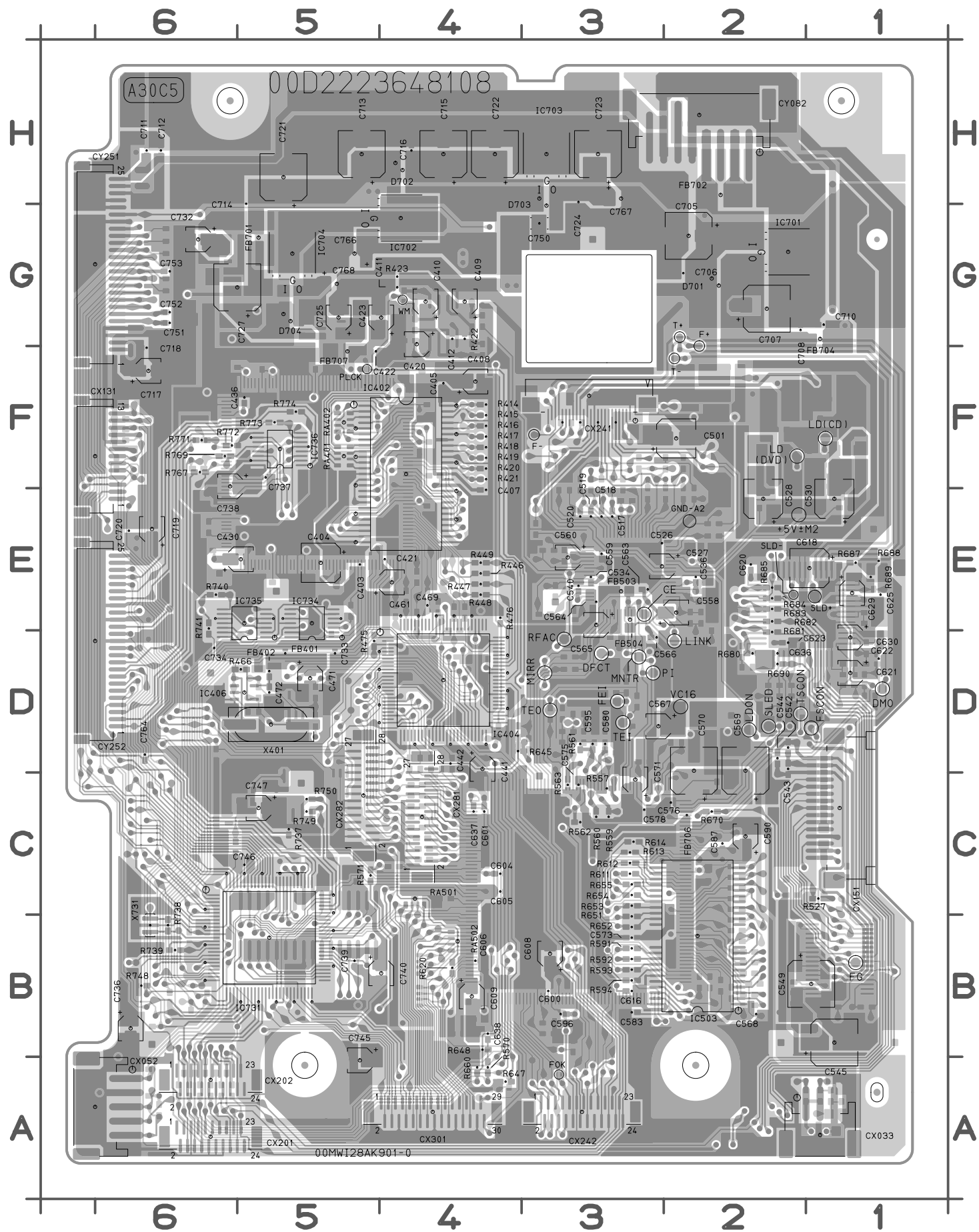

C403	E5	C630	D1	IC70	G2	R773	F5
C404	E5	C636	D2	IC70	G4	R774	F5
C405	F4	C637	C4	IC70	H3	RA40	F5
C407	E4	C638	B4	IC70	G5	RA40	F5
C408	F4	C705	G2	IC73	B5	RA50	C4
C409	G4	C706	G2	IC73	E5	RA50	B4
C410	G4	C707	G2	IC73	E5	X401	D5
C411	G4	C708	G2	IC73	F5	X731	B6
C412	G4	C710	G1	R414	F4		
C420	G4	C711	H6	R415	F4		
C421	E4	C712	H6	R416	F4		
C422	F5	C713	H5	R417	F4		
C423	G4	C714	H5	R418	F4		
C430	E5	C715	H4	R419	F4		
C436	F5	C716	H4	R420	F4		
C441	D4	C717	F6	R421	F4		
C442	D4	C718	F6	R422	G4		
C461	E4	C719	E6	R423	G4		
C469	E4	C720	E6	R446	E4		
C471	D5	C721	H5	R447	E4		
C472	D5	C722	H4	R448	E4		
C501	F2	C723	H3	R449	E4		
C517	E3	C724	H3	R466	D5		
C518	E3	C725	G5	R475	D5		
C519	E3	C727	G6	R476	E4		
C520	E3	C732	G6	R527	C1		
C526	E3	C733	D5	R557	C3		
C527	E3	C734	D6	R559	C3		
C528	E2	C736	B6	R560	C3		
C530	E1	C737	F5	R561	D3		
C534	E3	C738	F6	R562	C3		
C536	E2	C739	B5	R563	C3		
C540	E3	C740	B4	R570	A4		
C542	D2	C745	A5	R571	C5		
C543	D2	C746	C5	R591	B3		
C544	D2	C747	C5	R592	B3		
C545	B1	C750	G3	R593	B3		
C549	B1	C751	G6	R594	B3		
C558	E2	C752	G6	R611	C3		
C559	E3	C753	G6	R612	C3		
C560	E3	C764	D6	R613	C3		
C563	E3	C766	G5	R614	C3		
C564	E3	C767	H3	R620	B4		
C565	E3	C768	G5	R645	D4		
C566	D3	CX03	A1	R647	A4		
C567	D3	CX05	A7	R648	B4		
C568	B2	CX13	F7	R651	B3		
C569	D2	CX15	C1	R652	B3		
C570	D2	CX20	A6	R653	C3		
C571	C3	CX20	A6	R654	C3		
C573	B3	CX24	F3	R655	C3		
C575	C3	CX24	A3	R660	A4		
C576	C2	CX28	C4	R670	C2		
C578	C3	CX28	C5	R680	D2		
C580	D3	CX30	A4	R681	D2		
C583	B3	CY08	H2	R682	E2		
C587	C2	CY25	G7	R683	E2		
C590	C2	CY25	D7	R684	E2		
C595	D3	D701	G2	R685	E2		
C596	B3	D702	H4	R687	E1		
C600	B3	D703	G3	R688	E1		
C601	C4	D704	G5	R689	E1		
C604	C4	FB40	D5	R690	D2		
C605	C4	FB40	D5	R737	C5		
C606	B4	FB50	E3	R738	B6		
C608	B3	FB50	E3	R739	B6		
C609	B4	FB70	G5	R740	E6		
C616	B3	FB70	H2	R741	E6		
C618	E1	FB70	G1	R748	B6		
C620	E2	FB70	C2	R749	C5		
C621	D1	FB70	F5	R750	C5		
C622	D1	IC40	F4	R767	F6		
C623	D2	IC40	D4	R769	F6		
C625	E1	IC40	D5	R771	F6		
C629	E1	IC50	B2	R772	F6		

鉛フリー半田
 半田付けには、鉛フリー半田 (Sn-Ag-Cu) を使用してください。
Lead-free Solder
 When soldering, use the Lead-free Solder (Sn-Ag-Cu).

PWB NAME	POS. NO.	VERS. COLOR	PART NO. (FOR EUR)	PART NO. (MZ)	PART NAME	DESCRIPTION
1U-3648A	C-609		00D2544464951	00D2544464951	ELECT CAP.	CE67C0J220MT(MV-B) +REF
1U-3648A	C-612		nsp	00D2570512903	CER. CAP.	CK73F1E104ZT +1608
1U-3648A	C-615		nsp	00D2570509929	CER. CAP.	CK73B1H102KT +1608
1U-3648A	C-616		nsp	00D2570512903	CER. CAP.	CK73F1E104ZT +1608
1U-3648A	C-618		00D2544575905	00D2544575905	ELECT CAP.	CE67C1A330MT +REF
1U-3648A	C-619		nsp	00D2570511904	CER. CAP.	CK73F1H103ZT +1608
1U-3648A	C-620		nsp	00D2570511904	CER. CAP.	CK73F1H103ZT +1608
1U-3648A	C-621		00D2544464951	00D2544464951	ELECT CAP.	CE67C0J220MT(MV-B) +REF
1U-3648A	C-622		nsp	00D2570511904	CER. CAP.	CK73F1H103ZT +1608
1U-3648A	C-623		nsp	00D2570511904	CER. CAP.	CK73F1H103ZT +1608
1U-3648A	C-624		nsp	00D2570511904	CER. CAP.	CK73F1H103ZT +1608
1U-3648A	C-625		nsp	00D2570511904	CER. CAP.	CK73F1H103ZT +1608
1U-3648A	C-629		00D2544464951	00D2544464951	ELECT CAP.	CE67C0J220MT(MV-B) +REF
1U-3648A	C-630		00D2544464951	00D2544464951	ELECT CAP.	CE67C0J220MT(MV-B) +REF
1U-3648A	C-631		nsp	00D2570510950	CER. CAP.	CK73B1H682KT +1608
1U-3648A	C-632		nsp	00D2570510950	CER. CAP.	CK73B1H682KT +1608
1U-3648A	C-633		nsp	00D2570509929	CER. CAP.	CK73B1H102KT +1608
1U-3648A	C-634		nsp	00D2570506951	CER. CAP.	CC73CH1H101JT +1608
1U-3648A	C-635		nsp	00D2570506951	CER. CAP.	CC73CH1H101JT +1608
1U-3648A	C-636		nsp	00D2570501901	CER. CAP.	CK73B1H103KT (1608) +1608
1U-3648A	C-637		nsp	00D2570511904	CER. CAP.	CK73F1H103ZT +1608
1U-3648A	C-639		nsp	00D2570510950	CER. CAP.	CK73B1H682KT +1608
1U-3648A	C-701		nsp	00D2570512903	CER. CAP.	CK73F1E104ZT +1608
1U-3648A	C-702		nsp	00D2570512903	CER. CAP.	CK73F1E104ZT +1608
1U-3648A	C-703		nsp	00D2570512903	CER. CAP.	CK73F1E104ZT +1608
1U-3648A	C-704		nsp	00D2570512903	CER. CAP.	CK73F1E104ZT +1608
1U-3648A	C-705		00D2544464906	00D2544464906	ELECT CAP.	CE67C0J101MT +REF
1U-3648A	C-706		nsp	00D2570512903	CER. CAP.	CK73F1E104ZT +1608
1U-3648A	C-707		00D2544464906	00D2544464906	ELECT CAP.	CE67C0J101MT +REF
1U-3648A	C-708		nsp	00D2570512903	CER. CAP.	CK73F1E104ZT +1608
1U-3648A	C-709		00D2590015901	00D2590015901	EMI FILTER	NFM41CC223R2A3L +C
1U-3648A	C-710		nsp	00D2570512903	CER. CAP.	CK73F1E104ZT +1608
1U-3648A	C-711		nsp	00D2570512903	CER. CAP.	CK73F1E104ZT +1608
1U-3648A	C-712		nsp	00D2570512903	CER. CAP.	CK73F1E104ZT +1608
1U-3648A	C-713		00D2544464906	00D2544464906	ELECT CAP.	CE67C0J101MT +REF
1U-3648A	C-714		nsp	00D2570512903	CER. CAP.	CK73F1E104ZT +1608
1U-3648A	C-715		00D2544464906	00D2544464906	ELECT CAP.	CE67C0J101MT +REF
1U-3648A	C-716		nsp	00D2570512903	CER. CAP.	CK73F1E104ZT +1608
1U-3648A	C-717		00D2544464951	00D2544464951	ELECT CAP.	CE67C0J220MT(MV-B) +REF
1U-3648A	C-718		nsp	00D2570512903	CER. CAP.	CK73F1E104ZT +1608
1U-3648A	C-719		00D2544464951	00D2544464951	ELECT CAP.	CE67C0J220MT(MV-B) +REF
1U-3648A	C-720		nsp	00D2570512903	CER. CAP.	CK73F1E104ZT +1608
1U-3648A	C-721		00D2544464906	00D2544464906	ELECT CAP.	CE67C0J101MT +REF
1U-3648A	C-722		00D2544464906	00D2544464906	ELECT CAP.	CE67C0J101MT +REF
1U-3648A	C-723		00D2544464906	00D2544464906	ELECT CAP.	CE67C0J101MT +REF
1U-3648A	C-724		nsp	00D2570512903	CER. CAP.	CK73F1E104ZT +1608
1U-3648A	C-725		00D2544464951	00D2544464951	ELECT CAP.	CE67C0J220MT(MV-B) +REF
1U-3648A	C-726		nsp	00D2570512903	CER. CAP.	CK73F1E104ZT +1608
1U-3648A	C-727		00D2544464906	00D2544464906	ELECT CAP.	CE67C0J101MT +REF
1U-3648A	C-730		nsp	00D2570512903	CER. CAP.	CK73F1E104ZT +1608
1U-3648A	C-731		nsp	00D2570516954	CER. CAP.	CK73B1E104KT +1608
1U-3648A	C-732		00D2544464951	00D2544464951	ELECT CAP.	CE67C0J220MT(MV-B) +REF
1U-3648A	C-733		nsp	00D2570512903	CER. CAP.	CK73F1E104ZT +1608
1U-3648A	C-734		nsp	00D2570512903	CER. CAP.	CK73F1E104ZT +1608
1U-3648A	C-735		nsp	00D2570512903	CER. CAP.	CK73F1E104ZT +1608
1U-3648A	C-736		00D2544464951	00D2544464951	ELECT CAP.	CE67C0J220MT(MV-B) +REF
1U-3648A	C-737		nsp	00D2570512903	CER. CAP.	CK73F1E104ZT +1608
1U-3648A	C-738		00D2544464951	00D2544464951	ELECT CAP.	CE67C0J220MT(MV-B) +REF
1U-3648A	C-739		nsp	00D2570512903	CER. CAP.	CK73F1E104ZT +1608
1U-3648A	C-740		00D2544464951	00D2544464951	ELECT CAP.	CE67C0J220MT(MV-B) +REF
1U-3648A	C-741		nsp	00D2570512903	CER. CAP.	CK73F1E104ZT +1608
1U-3648A	C-742		00D2590015901	00D2590015901	EMI FILTER	NFM41CC223R2A3L +C
1U-3648A	C-743		nsp	00D2570512903	CER. CAP.	CK73F1E104ZT +1608
1U-3648A	C-744		nsp	00D2570512903	CER. CAP.	CK73F1E104ZT +1608
1U-3648A	C-745		00D2544464951	00D2544464951	ELECT CAP.	CE67C0J220MT(MV-B) +REF
1U-3648A	C-746		nsp	00D2570512903	CER. CAP.	CK73F1E104ZT +1608
1U-3648A	C-747		00D2544464951	00D2544464951	ELECT CAP.	CE67C0J220MT(MV-B) +REF

NOTE : "nsp" PART IS LISTED FOR REFERENCE ONLY, MARANTZ WILL NOT SUPPLY THESE PARTS.

PWB NAME	POS. NO.	VERS. COLOR	PART NO. (FOR EUR)	PART NO. (MZ)	PART NAME	DESCRIPTION
1U-3648A	C-748		00D2590015901	00D2590015901	EMI FILTER	NFM41CC223R2A3L +C
1U-3648A	C-749		00D2590015901	00D2590015901	EMI FILTER	NFM41CC223R2A3L +C
1U-3648A	C-750		00D2590015901	00D2590015901	EMI FILTER	NFM41CC223R2A3L +C
1U-3648A	C-751		nsp	00D2570512903	CER. CAP.	CK73F1E104ZT +1608
1U-3648A	C-752		nsp	00D2570512903	CER. CAP.	CK73F1E104ZT +1608
1U-3648A	C-753		nsp	00D2570512903	CER. CAP.	CK73F1E104ZT +1608
1U-3648A	C-764		nsp	00D2570512903	CER. CAP.	CK73F1E104ZT +1608
1U-3648A	CX033		nsp	nsp	CONN.	3P PH CON.BASE(L) +REF
1U-3648A	CX052		nsp	nsp	CONN.	5P PH CON.BASE(L) +REF
1U-3648A	CX131		nsp	nsp	CONN.	13P FFC BASE(FMNSMT) +REF
1U-3648A	CX151		nsp	nsp	CONN.	15P FFC BASE(P=1.0)L +REF
1U-3648A	CX241		nsp	nsp	CONN.	24P FFC BASE(FLZ-SM1 +REF
1U-3648A	CY082		nsp	nsp	CONN.	8P PH CON.BASE(L) +REF
1U-3648A	CY251		nsp	nsp	CONN.	25P FFC BASE(FMNSMT) +REF
1U-3648A	CY252		nsp	nsp	CONN.	25P FFC BASE(FMNSMT) +REF
1U-3648A	D-501		00D2760778900	00D2760778900	DIODE	1SS300-TE85L +C
1U-3648A	D-701		00D2760717903	00D2760717903	DIODE	1SS355 TE-17 +C
1U-3648A	D-702		00D2760717903	00D2760717903	DIODE	1SS355 TE-17 +C
1U-3648A	D-703		00D2760717903	00D2760717903	DIODE	1SS355 TE-17 +C
1U-3648A	D-704		00D2760717903	00D2760717903	DIODE	1SS355 TE-17 +C
1U-3648A	D-731		00D2760717903	00D2760717903	DIODE	1SS355 TE-17 +C
1U-3648A	FB401		00D2350136907	00D2350136907	COIL	FBMJ1608HS280NT +1608
1U-3648A	FB402		00D2350136907	00D2350136907	COIL	FBMJ1608HS280NT +1608
1U-3648A	FB501		00D2350130903	00D2350130903	COIL	CHIP EMIFIL(11A121) +1608
1U-3648A	FB502		00D2350160902	00D2350160902	COIL	FB M J2125HM330-T +C
1U-3648A	FB503		00D2350160902	00D2350160902	COIL	FB M J2125HM330-T +C
1U-3648A	FB504		00D2350160902	00D2350160902	COIL	FB M J2125HM330-T +C
1U-3648A	FB505		00D2350160902	00D2350160902	COIL	FB M J2125HM330-T +C
1U-3648A	FB506		00D2350130903	00D2350130903	COIL	CHIP EMIFIL(11A121) +1608
1U-3648A	FB507		00D2350130903	00D2350130903	COIL	CHIP EMIFIL(11A121) +1608
1U-3648A	FB703		00D2350136907	00D2350136907	COIL	FBMJ1608HS280NT +1608
1U-3648A	FB704		00D2350160902	00D2350160902	COIL	FB M J2125HM330-T +C
1U-3648A	FB705		00D2350160902	00D2350160902	COIL	FB M J2125HM330-T +C
1U-3648A	FB706		00D2350136907	00D2350136907	COIL	FBMJ1608HS280NT +1608
1U-3648A	FB707		00D2350160902	00D2350160902	COIL	FB M J2125HM330-T +C
1U-3648A	FB708		00D2350160902	00D2350160902	COIL	FB M J2125HM330-T +C
1U-3648A	IC401		00D2623217003	00D2623217003	IC	CXD2753R +C
1U-3648A	IC402		00D2622875006	00D2622875006	IC	16M SDRAM(TSOP)-7/8 +C
1U-3648A	IC403		00D2623195905	00D2623195905	IC	AD8062-SO8 +C
1U-3648A	IC404		00D2623282009	00D2623282009	IC	EPM3128ATC100-10N(HARMONY-8LI)
1U-3648A	IC405		00D2623203907	00D2623203907	IC	TC7SHU04F-TE85L +REF
1U-3648A	IC406		00D2623203907	00D2623203907	IC	TC7SHU04F-TE85L +REF
1U-3648A	IC501		00D2623219001	00D2623219001	IC	CXD1881AR/BR +C
1U-3648A	IC502		00D2623218002	00D2623218002	IC	CXD1885Q +C
1U-3648A	IC503		00D2623409002	00D2623409002	IC	MSM51V18165F-50TSK-7
1U-3648A	IC505		00D2631109909	00D2631109909	IC	AN8471SA +C
1U-3648A	IC507		00D2621782909	00D2621782909	IC	TC7S08FTE85L +C
1U-3648A	IC508		00D2623221002	00D2623221002	IC	FAN8042 +C
1U-3648A	IC701		00D2631079903	00D2631079903	IC	BA033FP +C
1U-3648A	IC702		00D2631079903	00D2631079903	IC	BA033FP +C
1U-3648A	IC703		00D2622977904	00D2622977904	IC	BA18BC0FP-E2 +C
1U-3648A	IC704		00D2631182900	00D2631182900	IC	NJM2391DL1-26-TE1 +REF
1U-3648A	IC731		00D2623280111	00D2623280111	IC	M30624FGNGP-MZ0614 +REF
1U-3648A	IC732		00D2623310900	00D2623310900	IC	T14L1024N-12J(TAPE) +REF
1U-3648A	IC733		00D2623206904	00D2623206904	IC	S-80843CLNB-B64-T2 +C
1U-3648A	IC734		00D2623197903	00D2623197903	IC	TC74VHC74FT-EL +REF
1U-3648A	IC735		00D2623200900	00D2623200900	IC	TC74VHC00FT-EL +REF
1U-3648A	IC736		00D2623198902	00D2623198902	IC	TC74VHC157FT-EL +REF
1U-3648A	IC737		00D2623388903	00D2623388903	IC	AT24C04AN-10SI-1.8 +REF
1U-3648A	R-414		nsp	00D2472009983	CHIP RES.	RM73B--103JT +1608
1U-3648A	R-415		nsp	00D2472009983	CHIP RES.	RM73B--103JT +1608
1U-3648A	R-416		nsp	00D2472009983	CHIP RES.	RM73B--103JT +1608
1U-3648A	R-417		nsp	00D2472009983	CHIP RES.	RM73B--103JT +1608
1U-3648A	R-418		nsp	00D2472009983	CHIP RES.	RM73B--103JT +1608
1U-3648A	R-419		nsp	00D2472009983	CHIP RES.	RM73B--103JT +1608
1U-3648A	R-420		nsp	00D2472009983	CHIP RES.	RM73B--103JT +1608
1U-3648A	R-421		nsp	00D2472009983	CHIP RES.	RM73B--103JT +1608

NOTE : "nsp" PART IS LISTED FOR REFERENCE ONLY, MARANTZ WILL NOT SUPPLY THESE PARTS.

PWB NAME	POS. NO.	VERS. COLOR	PART NO. (FOR EUR)	PART NO. (MZ)	PART NAME	DESCRIPTION
1U-3648A	R-422		nsp	00D2472009983	CHIP RES.	RM73B--103JT +1608
1U-3648A	R-423		nsp	00D2472008968	CHIP RES.	RM73B--332JT +1608
1U-3648A	R-424		nsp	00D2472008926	CHIP RES.	RM73B--222JT +1608
1U-3648A	R-425		nsp	00D2472008913	CHIP RES.	RM73B--202JT +1608
1U-3648A	R-426		nsp	00D2472008913	CHIP RES.	RM73B--202JT +1608
1U-3648A	R-433		nsp	00D2472008926	CHIP RES.	RM73B--222JT +1608
1U-3648A	R-435		nsp	00D2472018903	CHIP RES.	RM73B--OR0KT +1608
1U-3648A	R-437		nsp	00D2472003947	CHIP RES.	RM73B--220JT +1608
1U-3648A	R-438		nsp	00D2472003947	CHIP RES.	RM73B--220JT +1608
1U-3648A	R-439		nsp	00D2472003947	CHIP RES.	RM73B--220JT +1608
1U-3648A	R-440		nsp	00D2472003947	CHIP RES.	RM73B--220JT +1608
1U-3648A	R-441		nsp	00D2472003947	CHIP RES.	RM73B--220JT +1608
1U-3648A	R-442		nsp	00D2472003947	CHIP RES.	RM73B--220JT +1608
1U-3648A	R-443		nsp	00D2472003947	CHIP RES.	RM73B--220JT +1608
1U-3648A	R-444		nsp	00D2472003947	CHIP RES.	RM73B--220JT +1608
1U-3648A	R-445		nsp	00D2472003947	CHIP RES.	RM73B--220JT +1608
1U-3648A	R-446		nsp	00D2472003947	CHIP RES.	RM73B--220JT +1608
1U-3648A	R-447		nsp	00D2472003947	CHIP RES.	RM73B--220JT +1608
1U-3648A	R-448		nsp	00D2472003947	CHIP RES.	RM73B--220JT +1608
1U-3648A	R-449		nsp	00D2472003947	CHIP RES.	RM73B--220JT +1608
1U-3648A	R-459		nsp	00D2472009983	CHIP RES.	RM73B--103JT +1608
1U-3648A	R-460		nsp	00D2472009983	CHIP RES.	RM73B--103JT +1608
1U-3648A	R-461		nsp	00D2472008942	CHIP RES.	RM73B--272JT +1608
1U-3648A	R-464		nsp	00D2472003989	CHIP RES.	RM73B--330JT +1608
1U-3648A	R-465		nsp	00D2472003989	CHIP RES.	RM73B--330JT +1608
1U-3648A	R-466		nsp	00D2472014965	CHIP RES.	RM73B--105JT +1608
1U-3648A	R-467		nsp	00D2472006944	CHIP RES.	RM73B--391JT +1608
1U-3648A	R-471		nsp	00D2472008926	CHIP RES.	RM73B--222JT +1608
1U-3648A	R-472		nsp	00D2472008926	CHIP RES.	RM73B--222JT +1608
1U-3648A	R-473		nsp	00D2472008926	CHIP RES.	RM73B--222JT +1608
1U-3648A	R-474		nsp	00D2472008926	CHIP RES.	RM73B--222JT +1608
1U-3648A	R-475		nsp	00D2472009983	CHIP RES.	RM73B--103JT +1608
1U-3648A	R-476		nsp	00D2472009983	CHIP RES.	RM73B--103JT +1608
1U-3648A	R-501		nsp	00D2472004988	CHIP RES.	RM73B--820JT +1608
1U-3648A	R-502		nsp	00D2472005903	CHIP RES.	RM73B--101JT +1608
1U-3648A	R-505		nsp	00D2472018903	CHIP RES.	RM73B--OR0KT +1608
1U-3648A	R-506		nsp	00D2472018903	CHIP RES.	RM73B--OR0KT +1608
1U-3648A	R-508		nsp	00D2472007985	CHIP RES.	RM73B--152JT +1608
1U-3648A	R-509		nsp	00D2472007985	CHIP RES.	RM73B--152JT +1608
1U-3648A	R-510		nsp	00D2472007985	CHIP RES.	RM73B--152JT +1608
1U-3648A	R-511		nsp	00D2472007985	CHIP RES.	RM73B--152JT +1608
1U-3648A	R-512		nsp	00D2472007985	CHIP RES.	RM73B--152JT +1608
1U-3648A	R-513		nsp	00D2472007985	CHIP RES.	RM73B--152JT +1608
1U-3648A	R-514		nsp	00D2472007985	CHIP RES.	RM73B--152JT +1608
1U-3648A	R-515		nsp	00D2472007985	CHIP RES.	RM73B--152JT +1608
1U-3648A	R-516		nsp	00D2472004946	CHIP RES.	RM73B--560JT +1608
1U-3648A	R-517		nsp	00D2472004946	CHIP RES.	RM73B--560JT +1608
1U-3648A	R-518		nsp	00D2472004946	CHIP RES.	RM73B--560JT +1608
1U-3648A	R-519		nsp	00D2472004946	CHIP RES.	RM73B--560JT +1608
1U-3648A	R-520		nsp	00D2472004920	CHIP RES.	RM73B--470JT +1608
1U-3648A	R-521		nsp	00D2472004920	CHIP RES.	RM73B--470JT +1608
1U-3648A	R-522		nsp	00D2472004920	CHIP RES.	RM73B--470JT +1608
1U-3648A	R-523		nsp	00D2472004920	CHIP RES.	RM73B--470JT +1608
1U-3648A	R-524		nsp	00D2472012941	CHIP RES.	RM73B--124JT +1608
1U-3648A	R-527		nsp	00D2472005903	CHIP RES.	RM73B--101JT +1608
1U-3648A	R-528		nsp	00D2472005903	CHIP RES.	RM73B--101JT +1608
1U-3648A	R-534		nsp	00D2472012941	CHIP RES.	RM73B--124JT +1608
1U-3648A	R-536		nsp	00D2472007943	CHIP RES.	RM73B--102JT +1608
1U-3648A	R-537		nsp	00D2472012925	CHIP RES.	RM73B--104JT +1608
1U-3648A	R-538		nsp	00D2472005961	CHIP RES.	RM73B--181JT +1608
1U-3648A	R-539		nsp	00D2472011942	CHIP RES.	RM73B--473JT +1608
1U-3648A	R-540		nsp	00D2472012925	CHIP RES.	RM73B--104JT +1608
1U-3648A	R-542		nsp	00D2472018903	CHIP RES.	RM73B--OR0KT +1608
1U-3648A	R-544		nsp	00D2472007943	CHIP RES.	RM73B--102JT +1608
1U-3648A	R-545		nsp	00D2472019960	CHIP RES.	RM73B--123FT +1608
1U-3648A	R-549		nsp	00D2472018903	CHIP RES.	RM73B--OR0KT +1608
1U-3648A	R-550		nsp	00D2472018903	CHIP RES.	RM73B--OR0KT +1608

NOTE : "nsp" PART IS LISTED FOR REFERENCE ONLY, MARANTZ WILL NOT SUPPLY THESE PARTS.

PWB NAME	POS. NO.	VERS. COLOR	PART NO. (FOR EUR)	PART NO. (MZ)	PART NAME	DESCRIPTION
1U-3648A	R-551		nsp	00D2472018903	CHIP RES.	RM73B--0R0KT +1608
1U-3648A	R-552		nsp	00D2472018903	CHIP RES.	RM73B--0R0KT +1608
1U-3648A	R-553		nsp	00D2472011900	CHIP RES.	RM73B--333JT +1608
1U-3648A	R-554		nsp	00D2472009983	CHIP RES.	RM73B--103JT +1608
1U-3648A	R-555		nsp	00D2472009983	CHIP RES.	RM73B--103JT +1608
1U-3648A	R-556		nsp	00D2472007943	CHIP RES.	RM73B--102JT +1608
1U-3648A	R-557		nsp	00D2472010969	CHIP RES.	RM73B--223JT +1608
1U-3648A	R-558		nsp	00D2472008900	CHIP RES.	RM73B--182JT +1608
1U-3648A	R-559		nsp	00D2472012925	CHIP RES.	RM73B--104JT +1608
1U-3648A	R-560		nsp	00D2472011942	CHIP RES.	RM73B--473JT +1608
1U-3648A	R-561		nsp	00D2472011984	CHIP RES.	RM73B--683JT +1608
1U-3648A	R-562		nsp	00D2472006960	CHIP RES.	RM73B--471JT +1608
1U-3648A	R-563		nsp	00D2472012967	CHIP RES.	RM73B--154JT +1608
1U-3648A	R-564		nsp	00D2472011942	CHIP RES.	RM73B--473JT +1608
1U-3648A	R-565		nsp	00D2472011968	CHIP RES.	RM73B--563JT +1608
1U-3648A	R-566		nsp	00D2472009983	CHIP RES.	RM73B--103JT +1608
1U-3648A	R-567		nsp	00D2472003989	CHIP RES.	RM73B--330JT +1608
1U-3648A	R-568		nsp	00D2472009983	CHIP RES.	RM73B--103JT +1608
1U-3648A	R-570		nsp	00D2472018903	CHIP RES.	RM73B--0R0KT +1608
1U-3648A	R-571		nsp	00D2472018903	CHIP RES.	RM73B--0R0KT +1608
1U-3648A	R-574		nsp	00D2472018903	CHIP RES.	RM73B--0R0KT +1608
1U-3648A	R-577		nsp	00D2472018903	CHIP RES.	RM73B--0R0KT +1608
1U-3648A	R-583		nsp	00D2472018903	CHIP RES.	RM73B--0R0KT +1608
1U-3648A	R-584		nsp	00D2472018903	CHIP RES.	RM73B--0R0KT +1608
1U-3648A	R-585		nsp	00D2472018903	CHIP RES.	RM73B--0R0KT +1608
1U-3648A	R-586		nsp	00D2472018903	CHIP RES.	RM73B--0R0KT +1608
1U-3648A	R-587		nsp	00D2472018903	CHIP RES.	RM73B--0R0KT +1608
1U-3648A	R-588		nsp	00D2472018903	CHIP RES.	RM73B--0R0KT +1608
1U-3648A	R-589		nsp	00D2472018903	CHIP RES.	RM73B--0R0KT +1608
1U-3648A	R-590		nsp	00D2472018903	CHIP RES.	RM73B--0R0KT +1608
1U-3648A	R-591		nsp	00D2472018903	CHIP RES.	RM73B--0R0KT +1608
1U-3648A	R-592		nsp	00D2472018903	CHIP RES.	RM73B--0R0KT +1608
1U-3648A	R-593		nsp	00D2472018903	CHIP RES.	RM73B--0R0KT +1608
1U-3648A	R-594		nsp	00D2472018903	CHIP RES.	RM73B--0R0KT +1608
1U-3648A	R-595		nsp	00D2472018903	CHIP RES.	RM73B--0R0KT +1608
1U-3648A	R-596		nsp	00D2472018903	CHIP RES.	RM73B--0R0KT +1608
1U-3648A	R-597		nsp	00D2472018903	CHIP RES.	RM73B--0R0KT +1608
1U-3648A	R-598		nsp	00D2472018903	CHIP RES.	RM73B--0R0KT +1608
1U-3648A	R-599		nsp	00D2472009983	CHIP RES.	RM73B--103JT +1608
1U-3648A	R-601		nsp	00D2472010969	CHIP RES.	RM73B--223JT +1608
1U-3648A	R-603		nsp	00D2472009983	CHIP RES.	RM73B--103JT +1608
1U-3648A	R-604		nsp	00D2472009983	CHIP RES.	RM73B--103JT +1608
1U-3648A	R-605		nsp	00D2472018916	CHIP RES.	RM73B--010KT +1608
1U-3648A	R-606		nsp	00D2472018916	CHIP RES.	RM73B--010KT +1608
1U-3648A	R-607		nsp	00D2472018916	CHIP RES.	RM73B--010KT +1608
1U-3648A	R-608		nsp	00D2472018916	CHIP RES.	RM73B--010KT +1608
1U-3648A	R-609		nsp	00D2472009983	CHIP RES.	RM73B--103JT +1608
1U-3648A	R-611		nsp	00D2472005903	CHIP RES.	RM73B--101JT +1608
1U-3648A	R-612		nsp	00D2472005903	CHIP RES.	RM73B--101JT +1608
1U-3648A	R-613		nsp	00D2472005903	CHIP RES.	RM73B--101JT +1608
1U-3648A	R-614		nsp	00D2472005903	CHIP RES.	RM73B--101JT +1608
1U-3648A	R-615		nsp	00D2472005903	CHIP RES.	RM73B--101JT +1608
1U-3648A	R-616		nsp	00D2472005903	CHIP RES.	RM73B--101JT +1608
1U-3648A	R-617		nsp	00D2472005903	CHIP RES.	RM73B--101JT +1608
1U-3648A	R-618		nsp	00D2472005903	CHIP RES.	RM73B--101JT +1608
1U-3648A	R-620		nsp	00D2472018903	CHIP RES.	RM73B--0R0KT +1608
1U-3648A	R-621		nsp	00D2472003947	CHIP RES.	RM73B--220JT +1608
1U-3648A	R-622		nsp	00D2472003947	CHIP RES.	RM73B--220JT +1608
1U-3648A	R-623		nsp	00D2472003947	CHIP RES.	RM73B--220JT +1608
1U-3648A	R-624		nsp	00D2472003947	CHIP RES.	RM73B--220JT +1608
1U-3648A	R-625		nsp	00D2472003947	CHIP RES.	RM73B--220JT +1608
1U-3648A	R-626		nsp	00D2472003947	CHIP RES.	RM73B--220JT +1608
1U-3648A	R-627		nsp	00D2472003947	CHIP RES.	RM73B--220JT +1608
1U-3648A	R-628		nsp	00D2472003947	CHIP RES.	RM73B--220JT +1608
1U-3648A	R-629		nsp	00D2472003947	CHIP RES.	RM73B--220JT +1608
1U-3648A	R-630		nsp	00D2472003947	CHIP RES.	RM73B--220JT +1608
1U-3648A	R-631		nsp	00D2472003947	CHIP RES.	RM73B--220JT +1608

NOTE : "nsp" PART IS LISTED FOR REFERENCE ONLY, MARANTZ WILL NOT SUPPLY THESE PARTS.

PWB NAME	POS. NO.	VERS. COLOR	PART NO. (FOR EUR)	PART NO. (MZ)	PART NAME	DESCRIPTION
1U-3648A	R-632		nsp	00D2472003947	CHIP RES.	RM73B--220JT +1608
1U-3648A	R-633		nsp	00D2472003947	CHIP RES.	RM73B--220JT +1608
1U-3648A	R-634		nsp	00D2472005903	CHIP RES.	RM73B--101JT +1608
1U-3648A	R-635		nsp	00D2472003989	CHIP RES.	RM73B--330JT +1608
1U-3648A	R-636		nsp	00D2472005903	CHIP RES.	RM73B--101JT +1608
1U-3648A	R-637		nsp	00D2472003989	CHIP RES.	RM73B--330JT +1608
1U-3648A	R-638		nsp	00D2472003989	CHIP RES.	RM73B--330JT +1608
1U-3648A	R-639		nsp	00D2472005903	CHIP RES.	RM73B--101JT +1608
1U-3648A	R-640		nsp	00D2472005903	CHIP RES.	RM73B--101JT +1608
1U-3648A	R-641		nsp	00D2472005903	CHIP RES.	RM73B--101JT +1608
1U-3648A	R-642		nsp	00D2472003989	CHIP RES.	RM73B--330JT +1608
1U-3648A	R-643		nsp	00D2472003989	CHIP RES.	RM73B--330JT +1608
1U-3648A	R-644		nsp	00D2472003989	CHIP RES.	RM73B--330JT +1608
1U-3648A	R-645		nsp	00D2472009983	CHIP RES.	RM73B--103JT +1608
1U-3648A	R-646		nsp	00D2472009983	CHIP RES.	RM73B--103JT +1608
1U-3648A	R-647		nsp	00D2472009983	CHIP RES.	RM73B--103JT +1608
1U-3648A	R-649		nsp	00D2472005903	CHIP RES.	RM73B--101JT +1608
1U-3648A	R-650		nsp	00D2472005903	CHIP RES.	RM73B--101JT +1608
1U-3648A	R-651		nsp	00D2472005903	CHIP RES.	RM73B--101JT +1608
1U-3648A	R-652		nsp	00D2472005903	CHIP RES.	RM73B--101JT +1608
1U-3648A	R-653		nsp	00D2472005903	CHIP RES.	RM73B--101JT +1608
1U-3648A	R-654		nsp	00D2472005903	CHIP RES.	RM73B--101JT +1608
1U-3648A	R-655		nsp	00D2472005903	CHIP RES.	RM73B--101JT +1608
1U-3648A	R-656		nsp	00D2472009983	CHIP RES.	RM73B--103JT +1608
1U-3648A	R-657		nsp	00D2472009983	CHIP RES.	RM73B--103JT +1608
1U-3648A	R-658		nsp	00D2472009983	CHIP RES.	RM73B--103JT +1608
1U-3648A	R-659		nsp	00D2472009983	CHIP RES.	RM73B--103JT +1608
1U-3648A	R-666		nsp	00D2472010969	CHIP RES.	RM73B--223JT +1608
1U-3648A	R-667		nsp	00D2472010969	CHIP RES.	RM73B--223JT +1608
1U-3648A	R-668		nsp	00D2472010969	CHIP RES.	RM73B--223JT +1608
1U-3648A	R-669		nsp	00D2472010969	CHIP RES.	RM73B--223JT +1608
1U-3648A	R-670		nsp	00D2472009912	CHIP RES.	RM73B--512JT +1608
1U-3648A	R-671		nsp	00D2472011968	CHIP RES.	RM73B--563JT +1608
1U-3648A	R-672		nsp	00D2472011968	CHIP RES.	RM73B--563JT +1608
1U-3648A	R-673		nsp	00D2472011968	CHIP RES.	RM73B--563JT +1608
1U-3648A	R-674		nsp	00D2472011900	CHIP RES.	RM73B--333JT +1608
1U-3648A	R-675		nsp	00D2472011900	CHIP RES.	RM73B--333JT +1608
1U-3648A	R-676		nsp	00D2472011900	CHIP RES.	RM73B--333JT +1608
1U-3648A	R-677		nsp	00D2472009983	CHIP RES.	RM73B--103JT +1608
1U-3648A	R-678		nsp	00D2472009983	CHIP RES.	RM73B--103JT +1608
1U-3648A	R-679		nsp	00D2472009983	CHIP RES.	RM73B--103JT +1608
1U-3648A	R-680		nsp	00D2472018903	CHIP RES.	RM73B--0R0KT +1608
1U-3648A	R-681		nsp	00D2472018903	CHIP RES.	RM73B--0R0KT +1608
1U-3648A	R-682		nsp	00D2472018903	CHIP RES.	RM73B--0R0KT +1608
1U-3648A	R-683		nsp	00D2472018903	CHIP RES.	RM73B--0R0KT +1608
1U-3648A	R-684		nsp	00D2472018903	CHIP RES.	RM73B--0R0KT +1608
1U-3648A	R-685		nsp	00D2472018903	CHIP RES.	RM73B--0R0KT +1608
1U-3648A	R-686		nsp	00D2472009983	CHIP RES.	RM73B--103JT +1608
1U-3648A	R-687		nsp	00D2472013982	CHIP RES.	RM73B--474JT +1608
1U-3648A	R-688		nsp	00D2472008926	CHIP RES.	RM73B--222JT +1608
1U-3648A	R-689		nsp	00D2472007943	CHIP RES.	RM73B--102JT +1608
1U-3648A	R-690		nsp	00D2472009983	CHIP RES.	RM73B--103JT +1608
1U-3648A	R-691		nsp	00D2472005903	CHIP RES.	RM73B--101JT +1608
1U-3648A	R-692		nsp	00D2472005903	CHIP RES.	RM73B--101JT +1608
1U-3648A	R-693		nsp	00D2472005903	CHIP RES.	RM73B--101JT +1608
1U-3648A	R-694		nsp	00D2472005903	CHIP RES.	RM73B--101JT +1608
1U-3648A	R-699		nsp	00D2472010969	CHIP RES.	RM73B--223JT +1608
1U-3648A	R-732		nsp	00D2472009983	CHIP RES.	RM73B--103JT +1608
1U-3648A	R-733		nsp	00D2472009941	CHIP RES.	RM73B--682JT +1608
1U-3648A	R-734		nsp	00D2472009967	CHIP RES.	RM73B--822JT +1608
1U-3648A	R-735		nsp	00D2472008984	CHIP RES.	RM73B--392JT +1608
1U-3648A	R-736		nsp	00D2472005987	CHIP RES.	RM73B--221JT +1608
1U-3648A	R-737		nsp	00D2472010969	CHIP RES.	RM73B--223JT +1608
1U-3648A	R-739		nsp	00D2472009983	CHIP RES.	RM73B--103JT +1608
1U-3648A	R-740		nsp	00D2472002964	CHIP RES.	RM73B--100JT +1608
1U-3648A	R-743		nsp	00D2472009925	CHIP RES.	RM73B--562JT +1608
1U-3648A	R-744		nsp	00D2472010969	CHIP RES.	RM73B--223JT +1608

NOTE : "nsp" PART IS LISTED FOR REFERENCE ONLY, MARANTZ WILL NOT SUPPLY THESE PARTS.

PWB NAME	POS. NO.	VERS. COLOR	PART NO. (FOR EUR)	PART NO. (MZ)	PART NAME	DESCRIPTION
1U-3648A	R-745		nsp	00D2472010969	CHIP RES.	RM73B--223JT +1608
1U-3648A	R-746		nsp	00D2472010969	CHIP RES.	RM73B--223JT +1608
1U-3648A	R-747		nsp	00D2472010969	CHIP RES.	RM73B--223JT +1608
1U-3648A	R-748		nsp	00D2472009983	CHIP RES.	RM73B--103JT +1608
1U-3648A	R-749		nsp	00D2472009983	CHIP RES.	RM73B--103JT +1608
1U-3648A	R-750		nsp	00D2472009983	CHIP RES.	RM73B--103JT +1608
1U-3648A	R-751		nsp	00D2472009983	CHIP RES.	RM73B--103JT +1608
1U-3648A	R-752		nsp	00D2472007943	CHIP RES.	RM73B--102JT +1608
1U-3648A	R-753		nsp	00D2472007943	CHIP RES.	RM73B--102JT +1608
1U-3648A	R-754		nsp	00D2472007943	CHIP RES.	RM73B--102JT +1608
1U-3648A	R-762		nsp	00D2472009983	CHIP RES.	RM73B--103JT +1608
1U-3648A	R-763		nsp	00D2472010969	CHIP RES.	RM73B--223JT +1608
1U-3648A	R-766		nsp	00D2472010969	CHIP RES.	RM73B--223JT +1608
1U-3648A	R-767		nsp	00D2472003989	CHIP RES.	RM73B--330JT +1608
1U-3648A	R-768		nsp	00D2472003989	CHIP RES.	RM73B--330JT +1608
1U-3648A	R-769		nsp	00D2472003989	CHIP RES.	RM73B--330JT +1608
1U-3648A	R-770		nsp	00D2472003989	CHIP RES.	RM73B--330JT +1608
1U-3648A	R-771		nsp	00D2472003989	CHIP RES.	RM73B--330JT +1608
1U-3648A	R-772		nsp	00D2472003989	CHIP RES.	RM73B--330JT +1608
1U-3648A	R-773		nsp	00D2472003989	CHIP RES.	RM73B--330JT +1608
1U-3648A	R-774		nsp	00D2472003989	CHIP RES.	RM73B--330JT +1608
1U-3648A	RA401		00D2479003908	00D2479003908	CHIP RES.	MNR14=220JE0AB +C
1U-3648A	RA402		00D2479003908	00D2479003908	CHIP RES.	MNR14=220JE0AB +C
1U-3648A	RA501		00D2479007917	00D2479007917	CHIP RES.	MNR14=103JE0 +C
1U-3648A	RA502		00D2479007917	00D2479007917	CHIP RES.	MNR14=103JE0 +C
1U-3648A	RA503		00D2479007917	00D2479007917	CHIP RES.	MNR14=103JE0 +C
1U-3648A	RA504		00D2479007917	00D2479007917	CHIP RES.	MNR14=103JE0 +C
1U-3648A	TR511		00D2720166905	00D2720166905	TRS.	2SB798(DL/DK)-T1 +C
1U-3648A	TR512		00D2720166905	00D2720166905	TRS.	2SB798(DL/DK)-T1 +C
1U-3648A	TR513		00D2730384900	00D2730384900	TRS.	2SC2412KT96(S) +C
1U-3648A	X-401		00D3990901902	00D3990901902	X'TAL	XTAL(33.8688/HK-49) +REF
1U-3648A	X-731		00D3990887903	00D3990887903	X'TAL	CSTCE16MOV53-R0 +2125

NOTE : "nsp" PART IS LISTED FOR REFERENCE ONLY, MARANTZ WILL NOT SUPPLY THESE PARTS.