

SERVICE MANUAL

marantz.[®]

model SD225

Stereo Cassette Deck

MARANTZ DESIGN AND SERVICE

Using superior design and selected high grade components, MARANTZ Company has created the ultimate in stereo sound. Only original MARANTZ parts can insure that your MARANTZ product will continue to perform to the specifications for which it is famous.

Parts for your MARANTZ stereo are generally available within 72 hours throughout the nation via a toll-free line to our National Parts Depot in California. The sales professionals who take your call immediately refer to their own desk top computer terminal and can quickly determine the availability and price information you require. If, for some reason, your order should exceed our available stock, we usually can instantly provide an alternate replacement part or current delivery information. When the order is placed and confirmed, the computer simultaneously generates "hard copy" orders at the distribution center. As hard copies come directly from the computer to the national parts depot, your requested stock is assembled and prepared for shipment and placed on the first available carrier for delivery to you.

ORDERING PARTS

Phone orders will eliminate mail delays, and we encourage the use of this method. If you order by mail, use MARANTZ parts order forms which are available from our National Parts Depot located at the following address:

SUPERSCOPE NATIONAL PARTS DEPARTMENT
20525 Nordhoff Street
Chatsworth, California 91311
Phone: 1-800-423-5108
1-213-998-9333

The following information must be supplied to eliminate delays in processing your order:

1. Complete address.
2. Complete part numbers.
3. Complete description of parts.
4. Model number for which part is required (indicate MARANTZ).
5. Account number (for account customers only).

Direct consumers will be provided with the current retail price quotation on available parts in order to advise them of the cost of the parts and shipping.

OVERSEAS PARTS ORDERING

Parts may also be ordered from the following overseas addresses:

U.S.A.

Marantz Company, Inc.
National Service Dept.
P.O. Box 577
Chatsworth, CA 91311
U.S.A.

CANADA

Superscope Canada, Ltd.
3710 Nashua Drive
Mississauga
Ontario, Canada L4V1M5

AUSTRALIA

Marantz Australia
32 Cross Street
Brookvale, NSW 2100
Australia

JAPAN

Marantz Japan, Inc.
3622 Kamitsuruma
Sagamihara-shi
Kanagawa, Japan

EUROPE

Marantz Europe S.A.
326 Avenue Louise Bte 32
1050 Brussels
Belgium

Marantz France
4 rue Bernard Palissy
92600 Asnieres
France

Marantz Audio U.K., Ltd.
193 London Road
Staines, Middlesex
United Kingdom

Marantz Germany GMBH
Max-Planck-Strasse 22
6072 Dreieich
West Germany

Marantz Belgium
45 rue Auguste Van Zande
1080 Brussels
Belgium

Marantz Svenska A.B.
Svartviksvägen 56
Traneberg
Box 12016
161 12 Bromma
Sweden

Marantz Norske A.S.
Refstadalleen 13
Oslo 5
Norway

Marantz Denmark
Bregnerødvej 132b
3460 BIRKERØD
DENMARK

Marantz GMBH Austria
Wiedner Hauptstrasse 98
1050 WIEN
AUSTRIA

All of the above locations are fully equipped to take care of your total service needs. Because various countries have differing configuration requirements, it is necessary that you contact the service facility in your particular country. In the event that there is no service location listed for your country, please contact the nearest facility for the necessary assistance.

marantz®

TABLE OF CONTENTS

Section	Title	Page
1.	SHOCK, FIRE HAZARD SERVICE TEST	4
2.	TEST EQUIPMENT REQUIRED FOR SERVICING	4
3.	CIRCUIT AND ELECTRICAL DESCRIPTION	5
3.1	Switching from Recording to Playback and Vice Versa	5
3.2	Playback Equalizer Circuit	5
3.3	Recording Correction Circuit	5
3.4	Bias Current Setting Circuit	5
3.5	Dolby NR/MPX Filter	5
3.6	Recording/Playback Muting	5
3.7	Soft-Touch Push Button	6
3.8	Mechanical Shut-Off Mechanism	6
4.	DISASSEMBLY	7
4.1	Removing the Top Cover	7
4.2	Removing the Front Panel	7
4.3	Removing the Mechanism	7
4.4	Removing the Main Amp Circuit Board (PJ01)	7
	MECHANICAL ADJUSTMENTS	8
5.1	Adjusting the Flywheel Thrust	8
5.2	Adjusting the Motor Rulley	8
5.3	Adjusting the Play Take-Up Torque	8
5.4	Measuring the FF/REW Torque	8
5.5	Adjusting the Contact Clearance of the Starter Switch	9
6.	ELECTRICAL ADJUSTMENTS	10
6.1	Head Azimuth Adjustment	10
6.2	Tape Speed Adjustment	11
6.3	Playback Output Level Adjustment	11
6.4	LED Peak Level Meter Adjustment	12
6.5	Record-Playback Level Adjustment	12
6.6	Recording Bias Currents Adjustment	13
6.7	Record-Playback Frequency Response Adjustment	13
6.8	MPX Filter Adjustment	14
7.	DIAGRAMS	15
7.1	Level Diagram	15
7.2	Wiring Diagram	16
8.	EXPLODED VIEWS AND PARTS LIST	18
8.1	[C01-99] Front Panel	18
8.2	[C02-99] Top Cover and Main Chassis	19
8.3	[P01-99] Operation Levers	20
8.4	[P02-99] Head Chassis	20
8.5	[P03-99] Flywheel	21
8.6	[P04-99] Switch Location	21
8.7	[P05-99] Parts Assembled on Top of Chassis	22
8.8	[P06-99] Parts Assembled on Reverse of Chassis	23
8.9	[H01-99] Packing Materials	25
8.10	Electrical Parts List	26
9.	TECHNICAL SPECIFICATIONS	30

System Connection

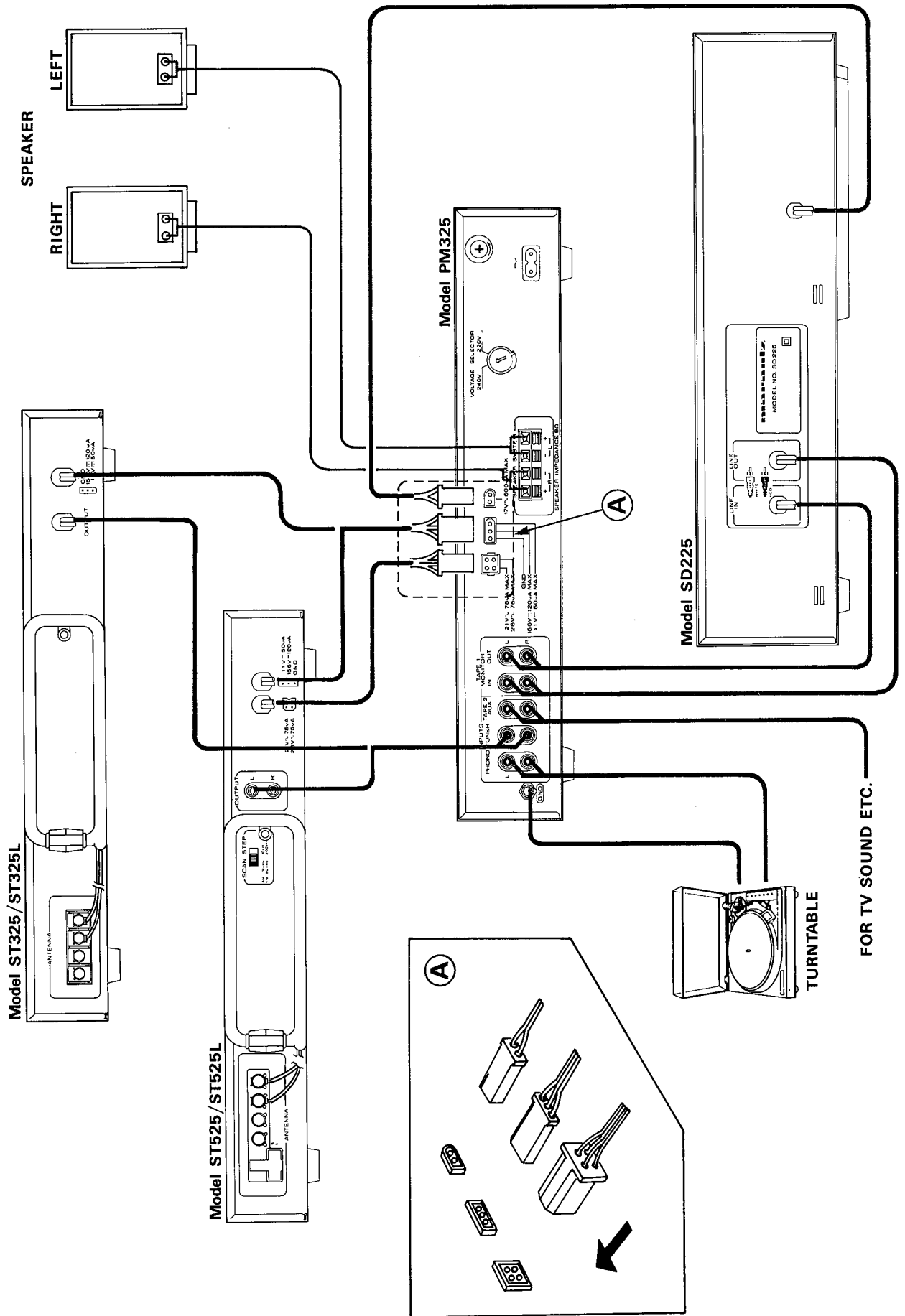

FOR TV SOUND ETC.

MARANTZ MODEL SD225 CASSETTE DECK

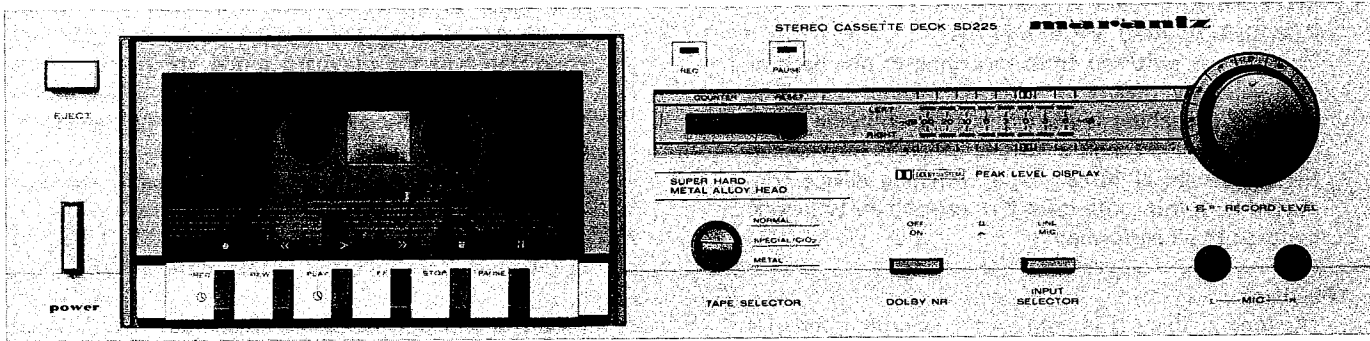

INTRODUCTION

This service manual is prepared for use by Authorized Warranty Station and contains service information for Marantz Stereo Cassette Deck.

Service information and voltage data included in this manual are intended for use by the knowledgeable and experienced technician only. All instructions should be read carefully. No attempt should be made to proceed without a good understanding of the operation of the Cassette Deck.

The parts list furnishes information by which replacement parts may be ordered from the Marantz Company. A simple description is included for parts which can be usually obtained through local suppliers.



1. SHOCK, FIRE HAZARD SERVICE TEST

CAUTION: After servicing this appliance and prior to returning to customer, measure the resistance between either primary AC cord connector pins (with unit NOT connected to AC mains and its Power switch ON), and the face or front Panel of product and controls and chassis bottom.

Any resistance measurement less than 1 Megohms should cause unit to be repaired or corrected before AC power is applied, and verified before return to user/customer.

Ref. UL Standard NO. 1270. Para. 66. 3. D (Mandatory Test after servicing Electrical Appliances, effective 7-1-83).

NOTE ON SAFETY:

SYMBOL  FIRE OR ELECTRICAL SHOCK HAZARD. ONLY ORIGINAL PARTS SHOULD BE USED TO REPLACE ANY PART MARKED WITH SYMBOL . ANY OTHER COMPONENT SUBSTITUTION (OTHER THAN ORIGINAL TYPE), MAY INCREASE RISK OF FIRE OR ELECTRICAL SHOCK HAZARD.

2. TEST EQUIPMENT REQUIRED FOR SERVICING

For measuring or checking your Cassette Deck, the following instruments and materials are necessary.

- VTVM
- Audio Oscillator (AF OSC)
- Attenuator (600 Ω)
- Oscilloscope
- Bandpass Filter (1 kHz)
- IEC A-Curve Filter
- Wow and Flutter Meter
- Torque Meter (Cassette Type)
- Digital Frequency Counter
- Distortion Meter
- Blank Tapes (Completely erased with bulk eraser)
 - TDK AC-212 (Normal)
 - TDK AC-512 (Special/CrO₂)
 - TDK AC-711 (Metal)

NOTE: If any doubt is noted in a measured value, use new tape.

- Test Tapes (New Tape)
 - MTT-111 Wow and Flutter, Tape Speed
 - MTT-112 Measurements of Output Level
 - MTT-112B Signal-to-Noise Ratio
 - MTT-150 Adjustment of Output Level
 - MTT-256 Frequency Response (for Normal)
 - MTT-356 Frequency Response (for Special/CrO₂ and Metal)
 - MTT-121 Cross Talk
 - MTT-141 Channel Separation
 - MTT-111 Wow and Flutter, Tape Speed

3. CONFIGURATION AND ELECTRICAL CIRCUIT DESCRIPTION

3.1 SWITCHING FROM RECORDING TO PLAYBACK AND VICE VERSA

This unit is switched from recording to playback or vice versa by means of a semiconductor switching device. Switching is carried out by applying a DC "high" signal through a switch which is interlocked by a mechanical force. The switching device connected with this route turns ON, causing the following controls to be performed.

Playback

(As long as there is no request for recording, the unit is in the playback mode.)

* Pin 12 of Q006 and pins 12 and 13 of Q005 are "high", so the switches between pins 1 and 2 and 11 and 10 of Q005 which connect the playback equalizer amplifier output to the Dolby amplifier are shorted. At this time, QU01 is ON, so pins 5 and 6 of Q005 which are connected to the collector are "low". As a result, the switches between pins 8 and 9 and pins 4 and 3 of Q005 which connect the mic amplifier to the Dolby amplifier are OFF.

* Pins 1, 3 and 5 of Q006 go "low" and pins 2, 4 and 6 turn "high". QK01 and QK02 are ON and the recording EQ amplifier input is muted. In addition, the diode switching method is used to switch the Dolby output. In the playback mode, the operations of Q006 described above cause DG03 and DG04 to serve as a signal path and apply a reversed bias to DG01 and DG02 so that no signal is allowed to pass through.

Recording

When the S073 switch is ON, the "high" signal specifying the recording mode is output. The switching devices connected to this route perform the following operations.

* Pins 8 and 11 of Q006 are "high", pins 9 and 10 of Q006 are "low", QU02 is ON and QU01 is OFF. Pins 5 and 6 of Q005 go "high". Accordingly, the switches between pins 4 and 3 and pins 8 and 9 of Q005 which connect the mic amplifier output to the Dolby amplifier turn ON, shorting the routes. In the playback system, on the other hand, pin 13 of Q006 is "high" and pin 12 of Q006 and pins 12 and 13 of Q005 go "low". As a result, the switches between pins 1 and 2 and pins 11 and 10 of Q005 are turned OFF.

* The bases of switching transistors QJ01 and QJ02 go "high", causing the transistors to enter the ON condition. In the playback mode, the head pins on the opposite side are grounded through 10Ω resistors RJ01 and RJ02 and the C to E paths of transistors QJ01 and QJ02.

In the playback system, on the other hand, the base of QU04 is "high" but its collector is "low". Accordingly, the switching devices QU03, QJ03 and QJ04 which are connected to this route are OFF.

* Pins 1, 3 and 5 of Q006 are "high" but pins 2, 4 and 6 are "low". QK01 and QK02 are OFF and the recording EQ amplifier input is no longer in the muted condition. Under this Q006 condition, the Dolby output is switched. That is, DG01 and DG02 now serve as a signal path but a reversed bias is applied to DG03 and DG04 so that no signal is allowed to flow.

3.2 PLAYBACK EQUALIZER CIRCUIT

The playback equalizer amplifier is fixed to 3180 and 120 μsec. by means of an NF elements. The CR elements is switched by the S102-1 switch and the electronic switching circuits QJ09 and QJ10 to give 70 μsec.

3.3 RECORDING CORRECTION CIRCUIT

In the recording mode, a position that is suitable for the tape is selected by means of the circuits of the tape selector switches S102-3 and S102-4. These switches are used to select recording sensitivity and the intermediate or high frequency correction elements.

3.4 BIAS CURRENT SETTING CIRCUIT

A bias current can be set for each tape by changing the input voltage of the recording bias oscillator which consists of RL06 to RL08. This input voltage can be changed by using the circuit of the tape selector switch S102-2.

3.5 DOLBY NR/MPX FILTER

The Dolby NR is switched by S103, an ON/OFF switch. The MPX filter is normally effective during both the recording and playback modes.

3.6 RECORDING/PLAYBACK MUTING

Transistors for muting are incorporated in the playback system (QG01 and QG02) as well as the recording system (QK01 and QK02). Connected to these transistors are transistors QU05 and QU06 which output a "high" signal for muting and a circuit having a time constant of 1.2 seconds. These muting transistors and time constant circuit result in a muting interval of 1.2 seconds during the rise time in the recording and playback modes. This time constant can be made slightly larger so as to allow for muting during power-on or timer-on.

3.7 SOFT-TOUCH PUSH BUTTON

The push buttons used so far are actuated by the mechanical force of a finger in contrast with the push buttons employed in this unit which require finger pressure only to generate mechanical power. The principal source of the mechanical power is the rotational power of a flywheel which allows soft operational commands such as a pressure of 0 to 400 grams on the button or a stroke of 3mm in length to be sensed.

3.8 MECHANICAL SHUT-OFF MECHANISM

The end of a tape is detected by means of a playback take-up torque. In the PLAY, REC, FF and REW modes, the rotation of the playback take-up torque is halted as the end of the tape is detected. At this time, the lock cam is released by the pin of the TMS tension arm (825N) and the cam of the TMS gear (831N). In this way, an auto shut-off operation is accomplished.

PIN CONNECTION DIAGRAMS OF IC'S USED IN THIS UNIT

Connection Diagram

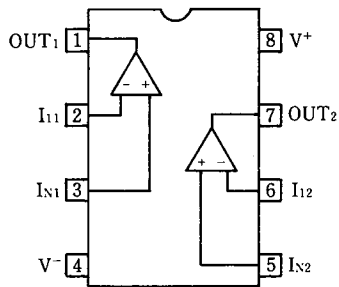

Block Diagram

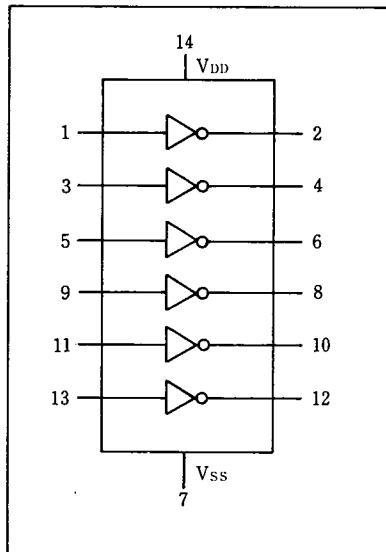

This IC consists of six inverters.

Block Diagram

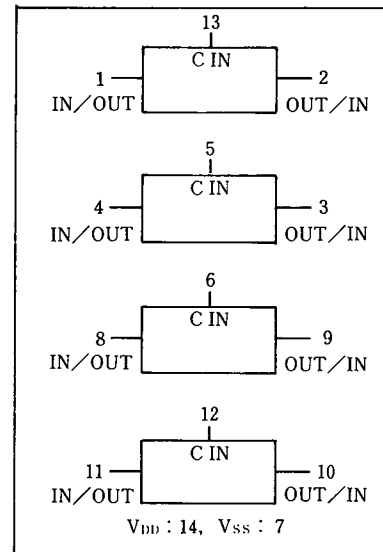

This IC consists of four independent bidirectional switches. When the control input CIN is set to the H level, the impedance between the input and output pins of the switch has a low value. On the other hand, applying an L level signal to CIN will make the value of the impedance high.

4. DISASSEMBLY

4.1 REMOVING THE TOP COVER

Remove the six screws 1~6.

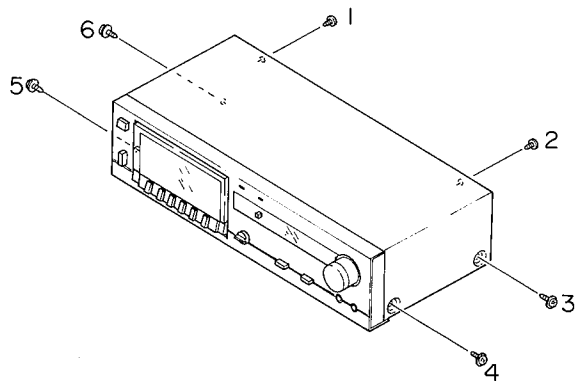

4.2 REMOVING THE FRONT PANEL

Remove the three screws 1~3.

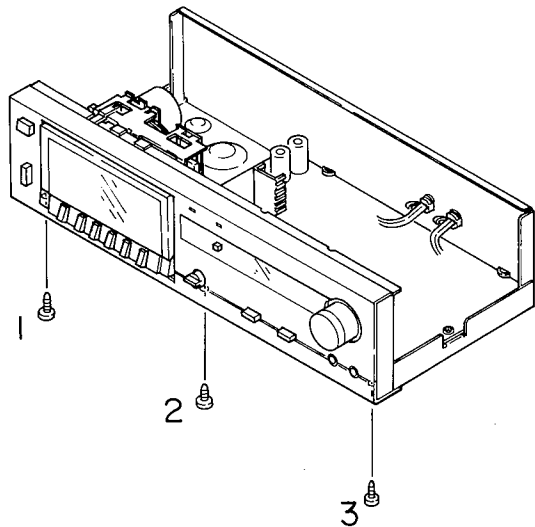

4.3 REMOVING THE MECHANISM

Remove the two screws 1 and 2.

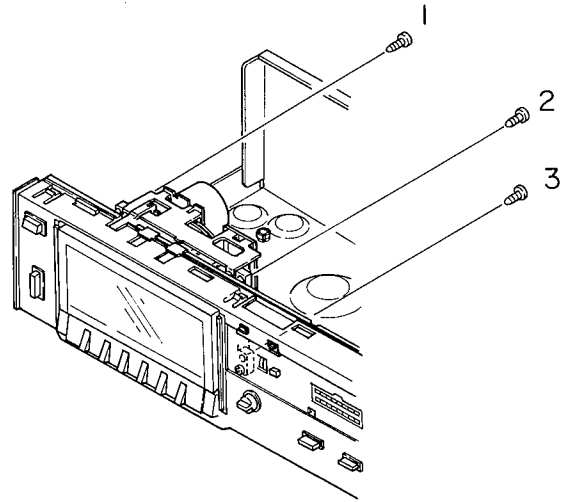

4.4 REMOVING THE MAIN AMP CIRCUIT BOARD (PJ01)

Remove the four screws 1~4.

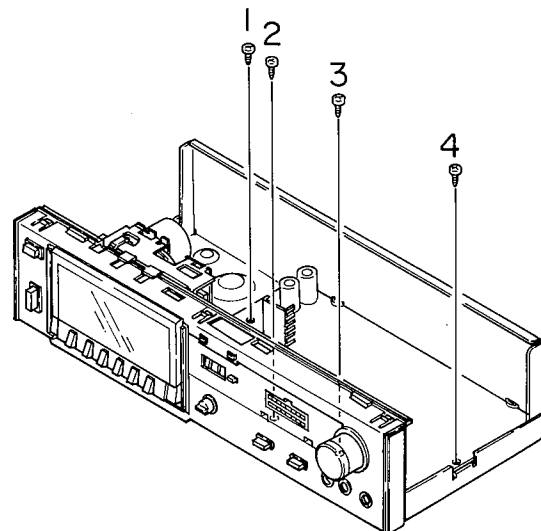

5. MECHANICAL ADJUSTMENTS

5.1 ADJUSTING THE FLYWHEEL THRUST

Adjust the thrust screw at the flywheel bracket until the clearance between the capstan tail end and the thrust bearing is 0.1 to 0.3 mm, using a philips screw driver. For adjusting, feel for axial dropping of the flywheel for proper clearance as this cannot be seen through.

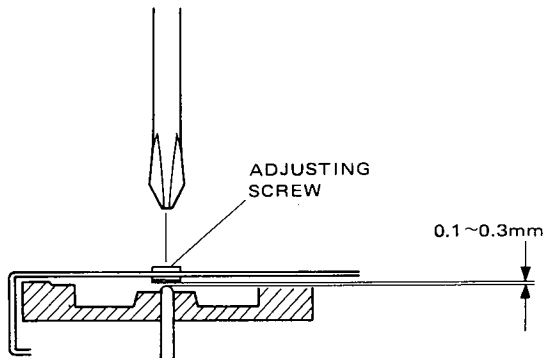

5.2 ADJUSTING THE MOTOR PULLEY

After putting the pulley on the motor shaft, attach the belt from the pulley to the flywheel. After turning the flywheel 2 or 3 times, properly position the pulley so that the belt is put on the center of the flywheel. Make sure the clearance between the pulley and the motor is approx. 1.6 mm.

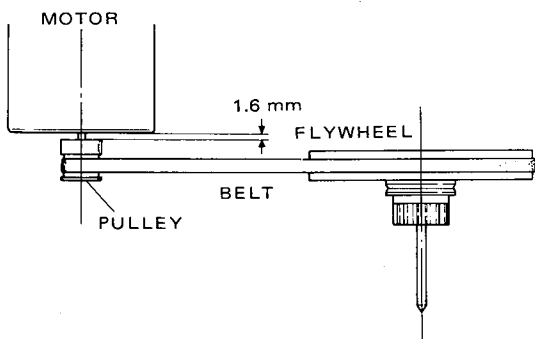

5.3 ADJUSTING THE PLAY TAKE-UP TORQUE

Set the plate spring in proper one of the six steps as shown.

The adjustable torque range is 40 to 65g-cm.

The torque variation ratio is approx. 5g-cm/step.

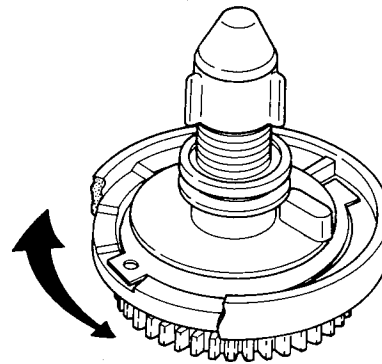

5.4 ADJUSTING THE FF/REW TORQUE

Set the plate spring in proper one of the four steps as shown.

The adjustable torque range is 75 to 120g-cm.

The torque variation ratio is 5 to 10g-cm/stop.

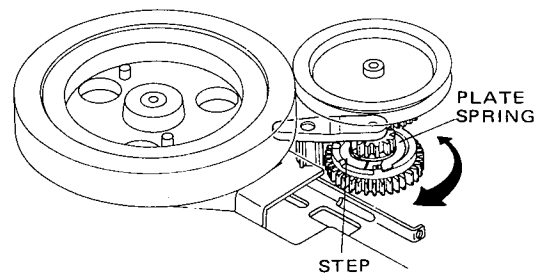

5.5 ADJUSTING THE CONTACT CLEARANCE OF THE STARTER SWITCH

When pushing the starter switch in stop mode of operation, if the motor is not running, adjust the contact clearance of starter switch by bending A portion until the clearance becomes 0.3 to 0.7 mm.

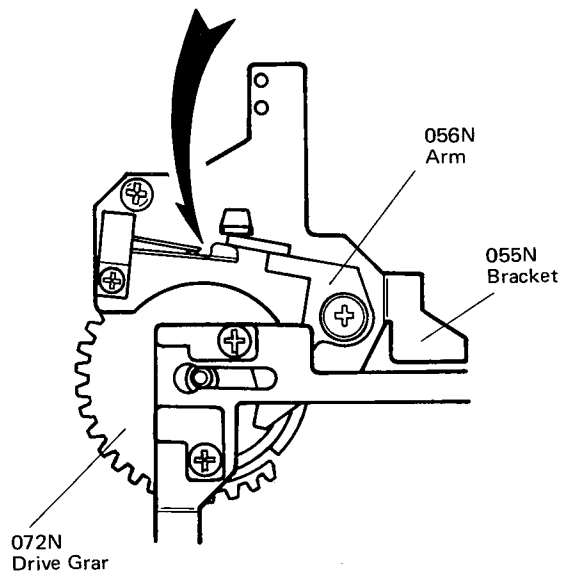
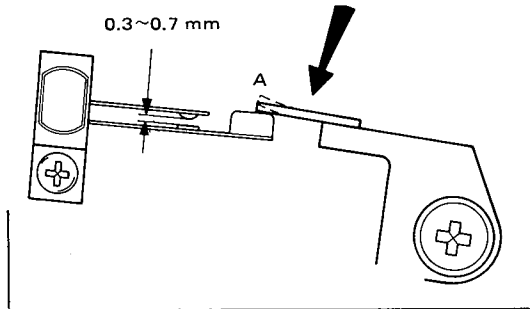

SWITCH LOCATION

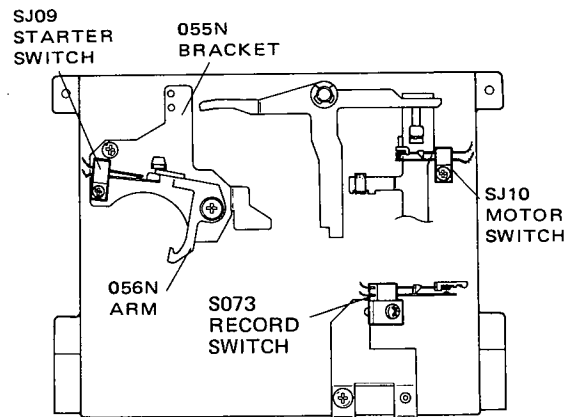
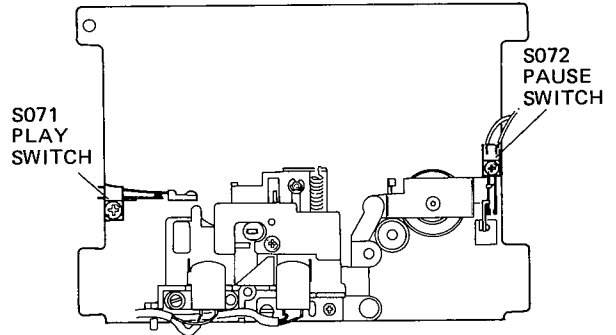

6. ELECTRICAL ADJUSTMENTS

Precautions before Adjustment

1. Before playing the test tape back, thoroughly demagnetize the heads, capstan and similar metal parts using an eraser as the test tape-recorded tone is easily erased.
2. Do not place the test tape on any measuring instrument.
3. Do not put the test tape near a place where the eraser is used.
4. Method of Demagnetization: — Turn the eraser power switch on at a remote position far away from the heads. Bring the eraser close to the heads, capstan and other parts to be demagnetized, and move it up and down four or five times to demagnetize. Slowly separate the eraser far away from the parts, and turn the power switch off.
5. Do not use any magnetized adjusting tool. When using it, demagnetize it from time to time in the course of each adjustment.
6. Do not turn semi-fixed resistor more than needed.
7. Do not apply locking bond excessively.

6.1 HEAD AZIMUTH ADJUSTMENT

1. Remove the cassette door lid and the escutcheon.
2. Set the TAPE SELECT switch to the NORM position.
3. Play the 14 kHz signal of the test tape MTT 256 back. Adjust the head azimuth adjusting screw for maximum VTVM reading.
4. If the peak output reads of the right and left channels are different, set the screws to obtain the mechanical center between the peaks.
5. After adjustment, repeat the playback and stop setting a few times to make certain of no head azimuth deviation. Then, lock the screws with bond.

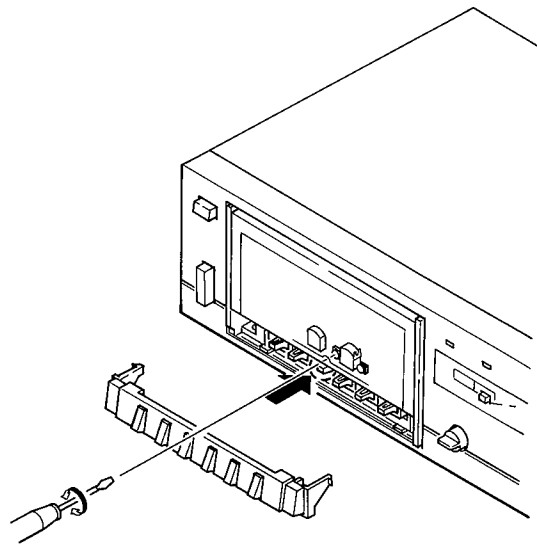
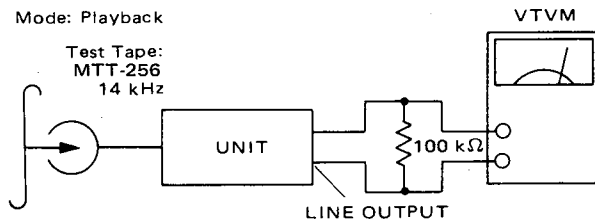

6.2 TAPE SPEED ADJUSTMENT

Play the 3 kHz signal of the test tape MTT-111 back. Adjust the tape speed adjusting resistor inside the motor (M001) for 2990 to 3010 Hz counter indication.

NOTES:

1. If a strong shock or similar vibration is applied to the deck after adjustment, make certain that the measured tape speed had not changed.
2. Be careful that the frequency counter may indicate a wrong value because of too low counter input level.
3. Before adjustment, allow for 30 seconds or more after depressing of the PLAY button.

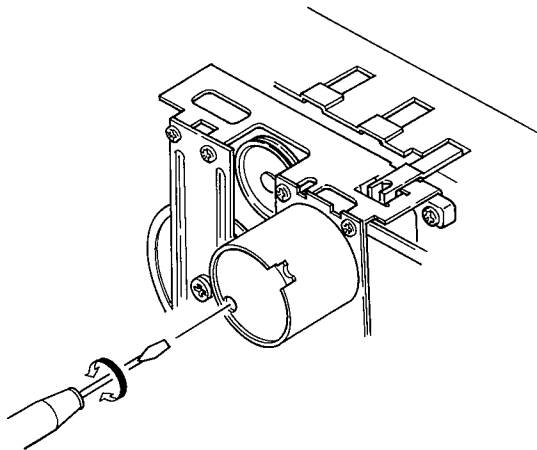
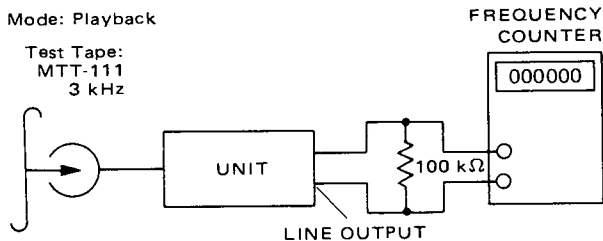

6.3 PLAYBACK OUTPUT LEVEL ADJUSTMENT

1. Set the TAPE SELECT switch to the NORM position.
2. Play the test tape MTT-150 back. Adjust RJ31(L) and RJ32(R) (50 kΩ each) for 580 mV playback output level at the test points TP5(L) and TP7 (GND), or TP6(R) and TP7(GND).

NOTES:

1. Proceed both for the right and left channels in the same manner.
2. This adjustment should be performed after the one for the "Playback Equalizer Adjustment".

Mode: Playback

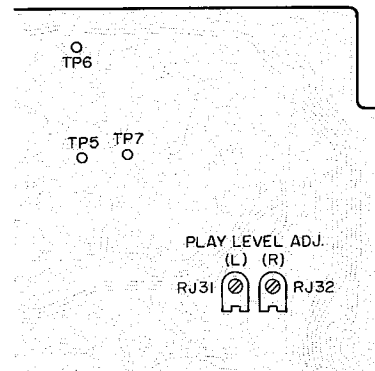
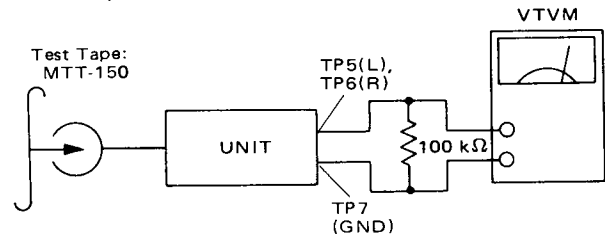

6.4 LED PEAK LEVEL METER ADJUSTMENT

1. Follow the same procedures as in the "Playback Output Level Adjustment" section.
2. Adjust RX05(L) and RX06(R) (50 k Ω each) for 0 dB LED PEAK LEVEL meter reading.

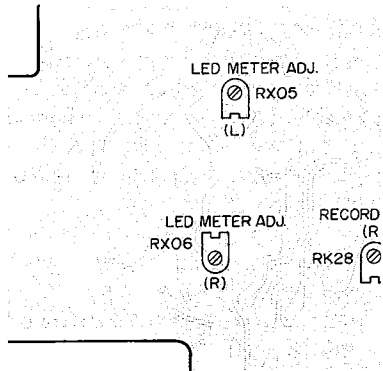

6.5 RECORD-PLAYBACK LEVEL ADJUSTMENT

1. Set the TAPE SELECT button to the NORM position.
2. Connect the 1 kHz, -60 dBV signal to the MIC jack. Set up the deck to the recording state.
3. Adjust the REC Level control for 0 dB LED PEAK LEVEL meter reading.
4. Play the recorder portion back and adjust RK27(L) and RK28(R) for 0 dB LED PEAK LEVEL meter reading.

Proceed both for the right and left channels in the same manner.

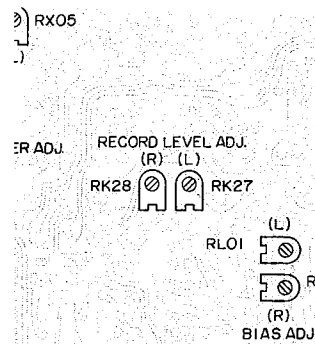

6.6 RECORDING BIAS CURRENT ADJUSTMENT

1. Set the TAPE SELECT switch to the NORM position.
2. Set up the deck to the recording state.
3. Adjust RL01(L) and RL02(R) for 3.8 mV reading (bias currents are 380 μ A) at the test points TP1(L) and TP2(L GND), or TP3(R) and TP4(R GND).
4. Make sure that the following values are obtained in each position except NORM.
SPECIAL/CrO₂ : 4.2 mV, METAL: 6.7 mV

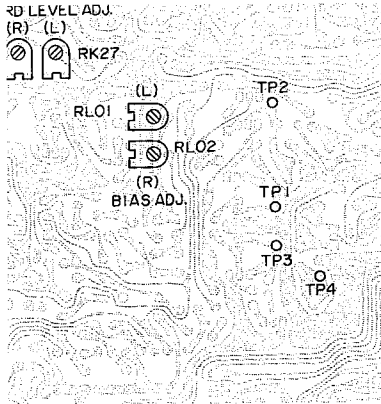

6.7 RECORD-PLAYBACK FREQUENCY RESPONSE ADJUSTMENT

1. Set the TAPE SELECT switch to the NORM position.
2. Connect the 1 kHz, -60 dB input signal to the MIC jack. Set up the tape deck to the normal recording state. Adjust the REC LEVEL control for 0 dB LED PEAK LEVEL meter reading.
3. In turn, reduce the input level by 23 dB with the attenuator. Record the 1 kHz and 12.5 kHz signals.
4. Play each recorded signal back: Adjust the recording bias current with RL01(L) and RL02(R) until the response is within ± 1 dB as reference to the 1 kHz, 0 dB response.

- NOTES:**
1. Proceed both for the right and left channels in the same manner.
 2. If the recording bias current is reduced in the above adjustment, be sure to measure the distortion.

Mode: Record

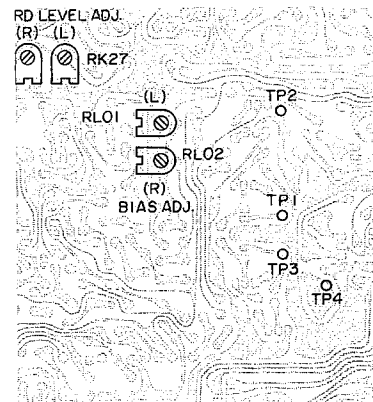
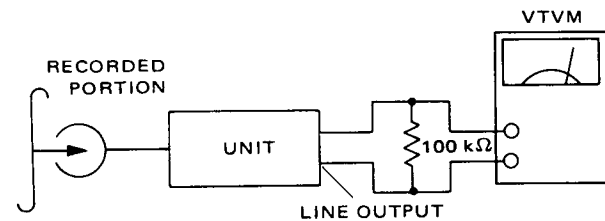
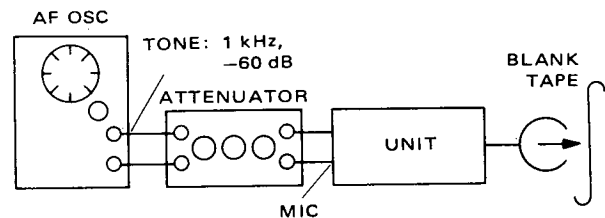

6.8 MPX FILTER ADJUSTMENT

1. Set the TAPE SELECT switch to the NORM position.
2. Connect the 1 kHz, 100 mV input signal to the LINE INPUT cord.
3. Set up the deck to the recording state.
4. Adjust the REC LEVEL control for 0 dB meter reading.
5. Adjust the line output level for 0 dB, and turn the DOLBY NR switch to the ON position.
6. Turn the input signal to the 19 kHz.
7. Adjust L601(L) and L602(R) for minimum output level.

NOTES:

1. Proceed both for the right and left channels in the same manner.
2. If the filter characteristic is better than 30 dB, the MPX filter needs not to be adjusted.

Mode: Record

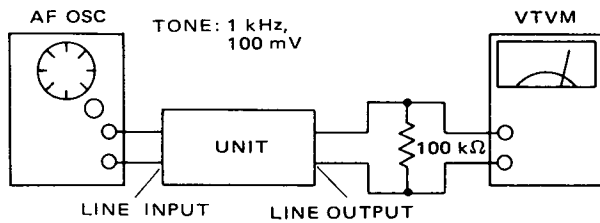

7. DIAGRAMS

7.1 LEVEL DIAGRAM

RECORD MODE

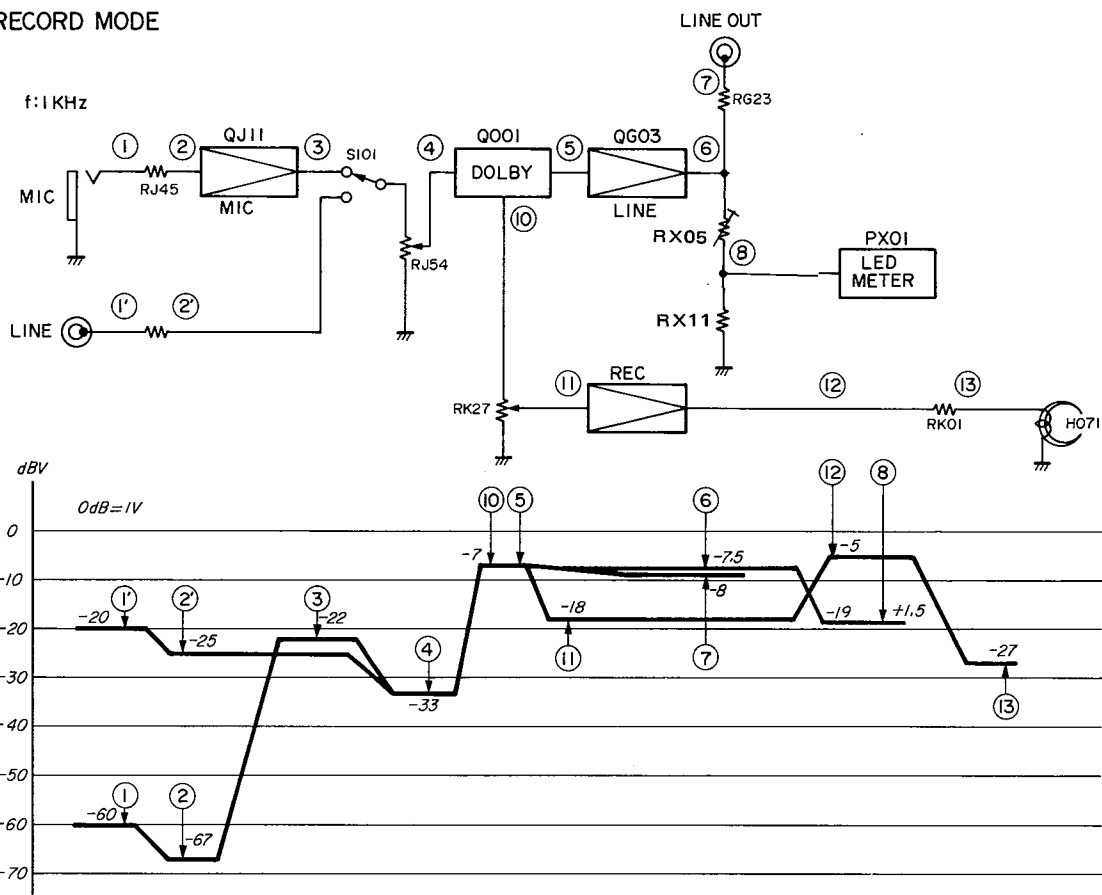

PLAY BACK MODE

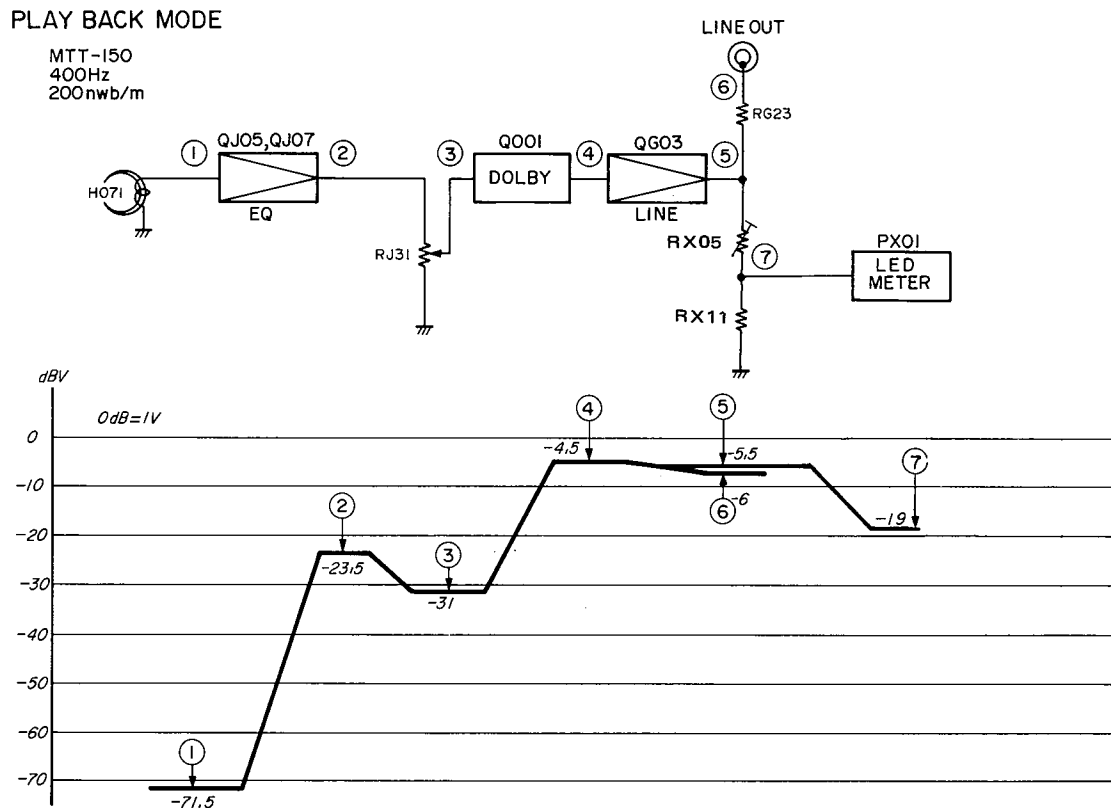

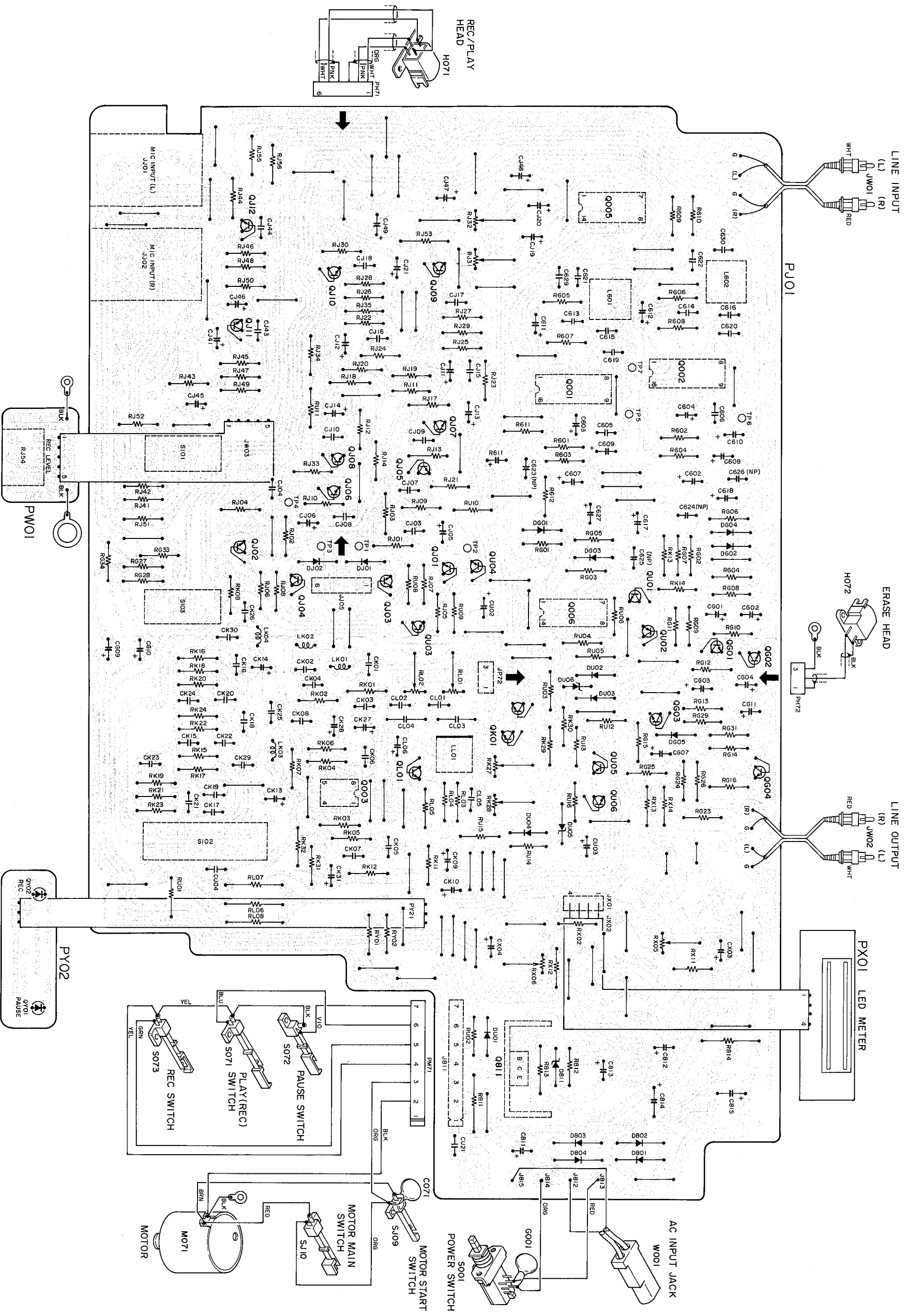

8. EXPLODED VIEWS AND PARTS LIST
8.1 [C01-99] FRONT PANEL

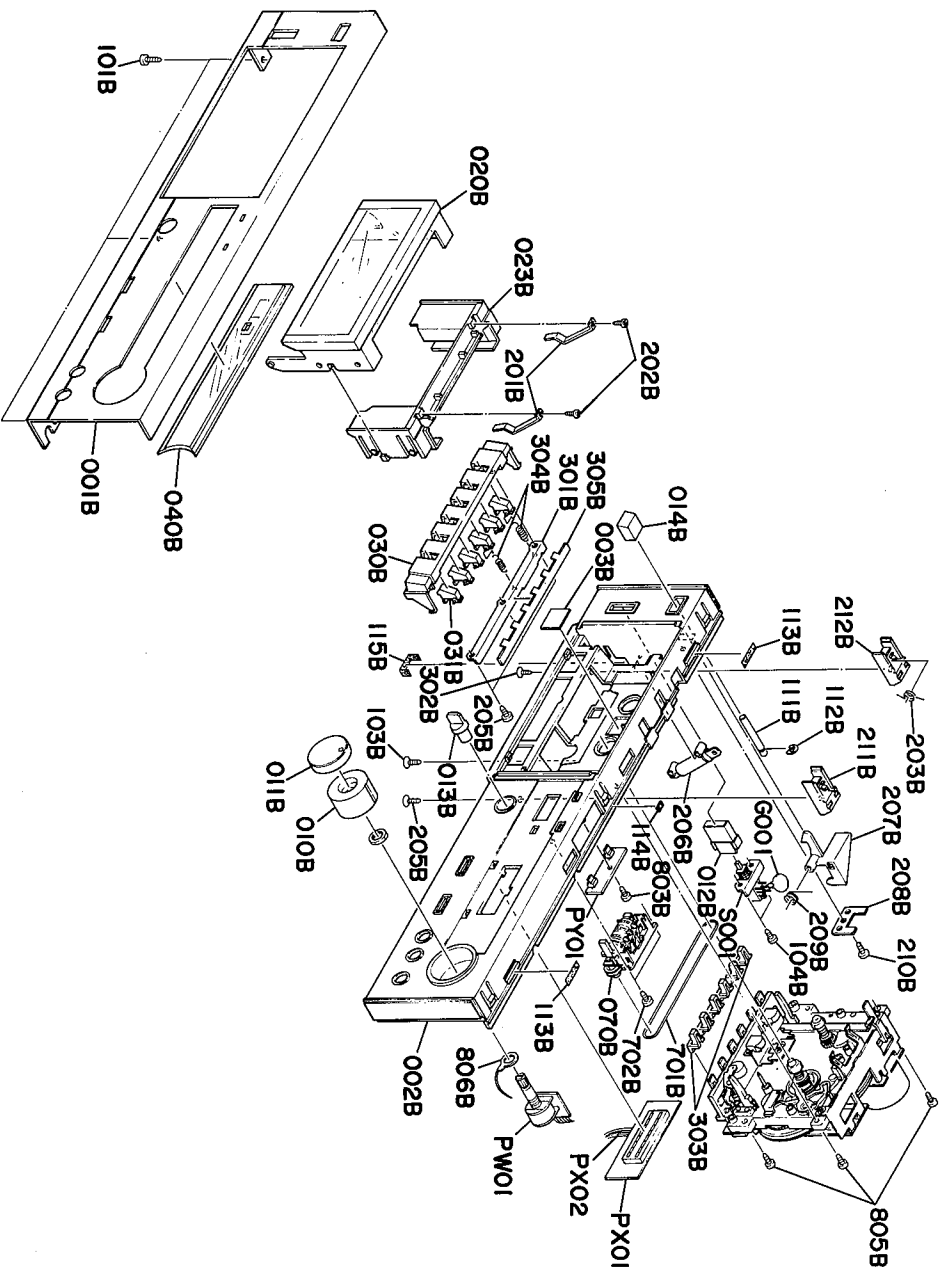

REF. DESIG.	QTY			PART NO.	DESCRIPTION
	U	C	N A		
A	1	1	1	131T063400	Front Panel Assembly
001B	1	1	1	131T063010	Escutcheon, Front Panel
040B	1	1	1	131T158020	Window, L.E.D.
002B	1	1	1	131T063020	Escutcheon, Front Chassis
003B	1	1	1	4279274020	Reflector
010B	1	1	1	102T154020	Knob, Rec Level (R)
011B	1	1	1	102T154010	Knob, Rec Level (L)
012B	1	1	1	226H154010	Knob, Power Switch
013B	1	1	1	124T154010	Knob, Tape Select
014B	1	1	1	120T154020	Knob, Elect
020B	1	1	1	131T158500	Window, Cassette Door
023B	1	1	1	124T271110	Holder
030B	1	1	1	131T064010	Case, Button
031B	6	6	6	124T270010	Button
070B	1	1	1	131T052010	Counter
101B	3	3	3	5128030880	B.H., Tapped Screw B3 x 8
103B	1	1	1	5150031080	F.H., Tapped Screw F3 x 10
104B	1	1	1	5128030880	B.H., Tapped Screw B3 x 8
111B	1	1	1	124T254010	Pin, Elect Knob
112B	1	1	1	64002500F0	RG Ring, E Type
113B	2	2	2	124T107020	Sheet
114B	1	1	1	124T107030	Sheet
115B	1	1	1	124T107040	Sheet

REF. DESIG.	QTY			PART NO.	DESCRIPTION
	U	C	N A		
201B	2	2	2	124T115010	Spring, Cassette
202B	2	2	2	51302604U0	P.H., Tapped Screw P2.6 x 4
203B	1	1	1	124T115020	Spring, Door Open
205B	2	2	2	5150031080	F.H., Tapped Screw F3 x 10
206B	1	1	1	120T276010	Piston, Dumper
207B	1	1	1	124T002010	Arm, Door Lock
208B	1	1	1	124T104030	Retainer
209B	1	1	1	124T115030	Spring
210B	1	1	1	5128030880	B.H., Tapped Screw B3 x 8
211B	1	1	1	124T104020	Retainer, (R)
212B	1	1	1	124T104040	Retainer, (L)
301B	1	1	1	124T104010	Retainer
302B	3	3	3	5128260880	B.H., Tapped Screw B2.6 x 6
303B	6	6	6	124T118010	Spacer, Button Lever
304B	2	2	2	307Y115140	Sheet
305B	2	2	2	124T107010	Sheet
701B	1	1	1	131T264010	Belt, Counter
702B	2	2	2	5128260880	B.H., Tapped Screw B2.6 x 8
803B	1	1	1	5128030880	B.H., Tapped Screw B3 x 8
805B	3	3	3	5128031080	B.H., Tapped Screw B3 x 10
806B	1	1	1	62100019E0	Lug
ΔS001	1	1	1	SP02010690	Push Switch, Power
ΔG001	1	1	1	DK18104010	Ceramic Cap, 0.1μF
PX01	1	1	1	H110801320	L.E.D. Meter
PX02	1	1	1	YU04260260	Jumper Lead, (4P)

8.2 [C02-99] TOP COVER AND MAIN CHASSIS

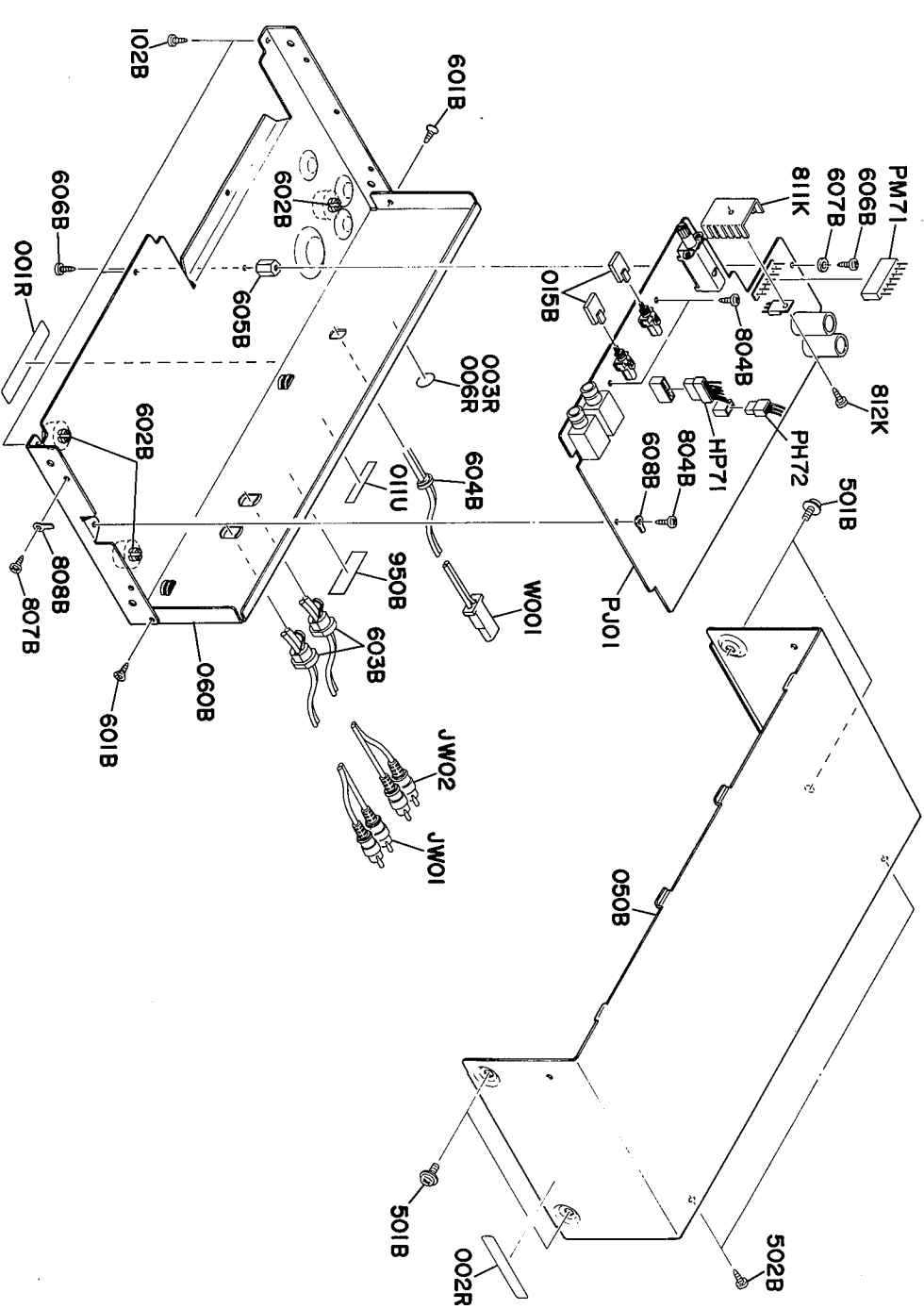

REF. DESIG.	QTY			PART NO.	DESCRIPTION
	U	C	N A		
015B	2	2	2	226H154140	Knob, Dolby/Input
050B	1	1	1	124T257110	Lid, Top Cover
060B	1	1	1	131T105120	Chassis, Rear Panel
060B	1	1	1	131T105110	Chassis, Rear Panel
102B	3	3	3	5128030880	B3 x 8
501B	4	4	4	51260408U0	B.T. Screw B4 x 8
502B	2	2	2	5128030880	B.H., Tapped Screw B3 x 8
601B	2	2	2	5150030680	F.H., Tapped Screw B3 x 8
602B	3	3	3	001T057010	Leg
603B	2	2	2	1455259030	Bushing, Pin Cord
604B	1	1	1	1455259030	Bushing, AC Cord
605B	1	1	1	124T101010	Support
606B	2	2	2	51100306A9	B.H.M. Screw B3 x 6
607B	1	1	1	59030810S0	Washer
608B	1	1	1	62031340W0	Lug
804B	3	3	3	5128030880	B.H., Tapped Screw B3 x 8
807B	1	1	1	5128030880	B.H., Tapped Screw B3 x 8
808B	1	1	1	62031650W0	Lug
950B	1	1	1	2112265010	Indicator
001R	1	1	1	2932861010	Label, Caution
001R	1	1	1	2911861110	Label, Caution
002R	1	1	1	2578861010	Label, Caution
002R	1	1	1	2911861140	Label, Caution
003R	1	1	1	9511101070	Label, UL
006R	1	1	1	2457861040	Label, CSA

REF. DESIG.	QTY			PART NO.	DESCRIPTION
	U	C	N A		
811K	1	1	1	202H267030	Heatsink
812K	1	1	1	5130030680	P.H., Tapped Screw P3 x 6
JW01	1	1	1	YB01001690	Connective Cord, Pin
JW01	1	1	1	YB01001680	Connective Cord, Pin
JW02	1	1	1	YB01001690	Connective Cord, Pin
JW02	1	1	1	YB01001680	Connective Cord, Pin
PM71	1	1	1	YJ06001060	Jack, (7P)
ΔW001	1	1	1	YB00500250	Connective Cord, (2P)
HP71	1	1	1	YB00400250	Connective Cord, (6P)
HP72	1	1	1	YB00400260	Connective Cord, (3P)
011U	1	1	1	4581861010	Label, Made in Japan

8.3 [P01-99] OPERATION LEVERS

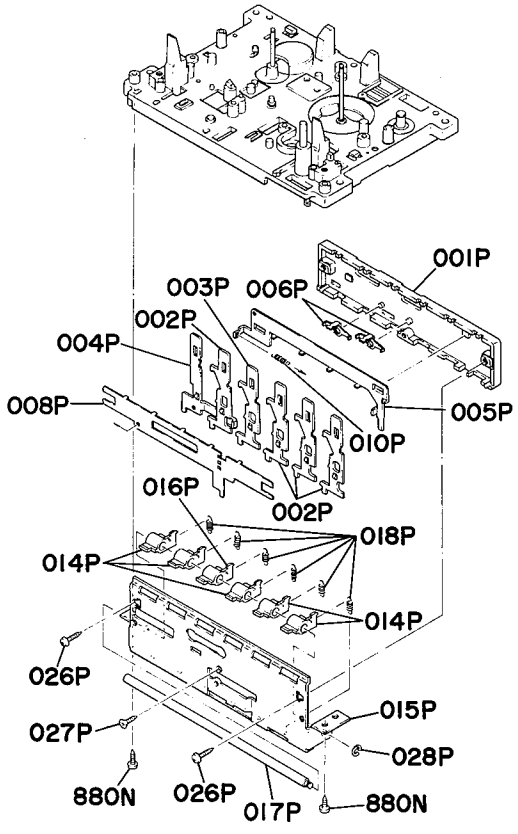

REF. DESIG.	Q'TY				PART NO.	DESCRIPTION
	U	C	N	A		
001P	1	1	1	1	307Y051010	Guide
002P	4	4	4	4	307Y354130	Lever
003P	1	1	1	1	307Y354140	Lever, Play
004P	1	1	1	1	307Y354150	Lever, Rec
005P	1	1	1	1	307Y354110	Lever, Starter
006P	2	2	2	2	307Y002120	Arm
008P	1	1	1	1	307Y054020	Cam Button Lock
010P	1	1	1	1	307Y115140	Spring, Lock Cam
014P	5	5	5	5	307Y002230	Arm
015P	1	1	1	1	307Y160020	Bracket
016P	1	1	1	1	307Y002040	Arm, Play
017P	1	1	1	1	307Y112070	Shaft
018P	6	6	6	6	307Y115120	Spring
026P	2	2	2	2	51302608B0	P.H. Tapped Screw P2.6 x 8
027P	1	1	1	1	51502606B0	F.H. Tapped Screw F2.6 x 6
028P	1	1	1	1	64002500R0	RG Ring, E Type
880N	2	2	2	2	51300308B0	P.H. Tapped Screw P3 x 8

8.4 [P02-99] HEAD CHASSIS

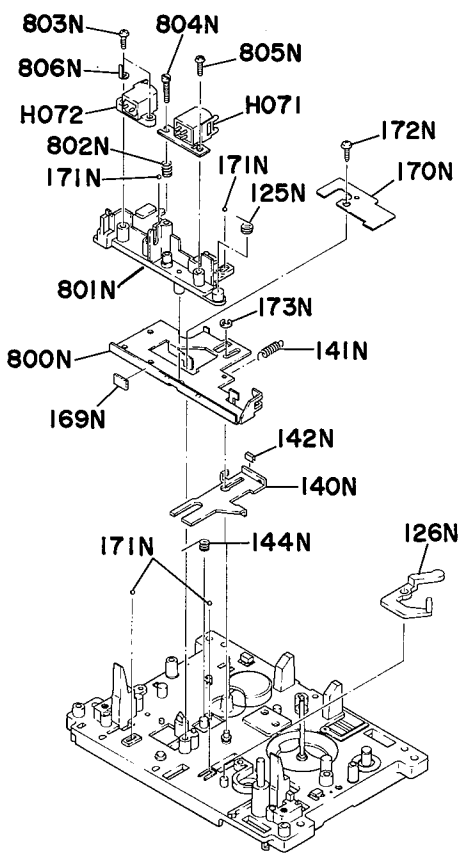

REF. DESIG.	Q'TY				PART NO.	DESCRIPTION
	U	C	N	A		
125N	1	1	1	1	307Y115230	Spring
126N	1	1	1	1	307Y002020	Arm, Take-up
140N	1	1	1	1	307Y354090	Lever
141N	1	1	1	1	307Y115110	Spring
142N	1	1	1	1	307Y056020	Buffer
144N	1	1	1	1	307Y115060	Spring
169N	1	1	1	1	307Y056010	Buffer
170N	1	1	1	1	307Y115030	Spring
171N	4	4	4	4	61020010T0	Ball
172N	1	1	1	1	51302606B0	P.H. Tapped Screw P2.6 x 6
173N	1	1	1	1	64001500R0	RG Ring, E Type
800N	1	1	1	1	307Y105020	Chassis, Head
801N	1	1	1	1	307Y160010	Bracket
802N	1	1	1	1	4380115090	Spring, Azimuth
803N	2	2	2	2	51100214A0	B.H.M. Screw B2 x 14
804N	1	1	1	1	51190213A0	Screw B2 x 13
805N	1	1	1	1	51100214A0	B.H.M. Screw B2 x 14
806N	1	1	1	1	62021030W0	Lug
H071	1	1	1	1	LH42851100	Rac/Play Head
H072	1	1	1	1	LH31000560	Erase Head

8.5 [P03-99] FLYWHEEL

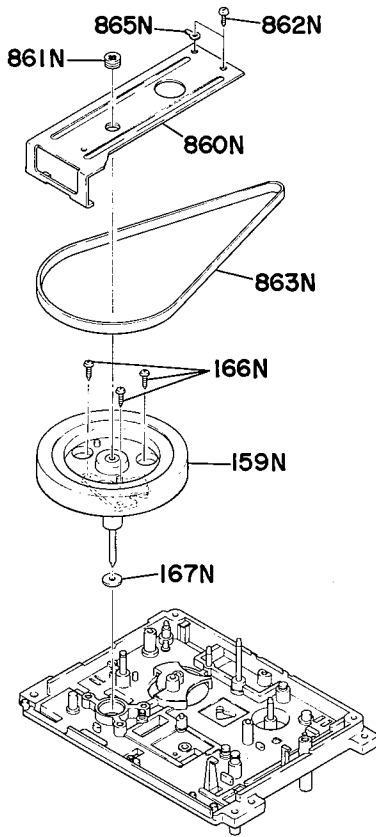

REF. DESIG.	Q'TY				PART NO.	DESCRIPTION
	U	C	N	A		
159N	1	1	1	1	307Y273400	Flywheel Assembly
166N	3	3	3	3	51302608B0	P.H. Tapped Screw P2.6 x 8
167N	1	1	1	1	306Y118010	Spacer
860N	1	1	1	1	307Y104010	Retainer
861N	1	1	1	1	3483164010	Adjuster
862N	2	2	2	2	51572604B0	P. Taptite Screw P2.6 x 4
863N	1	1	1	1	4380264030	Belt, Motor
865N	1	1	1	1	62031340W0	Lug

8.6 [P04-99] SWITCH LOCATION

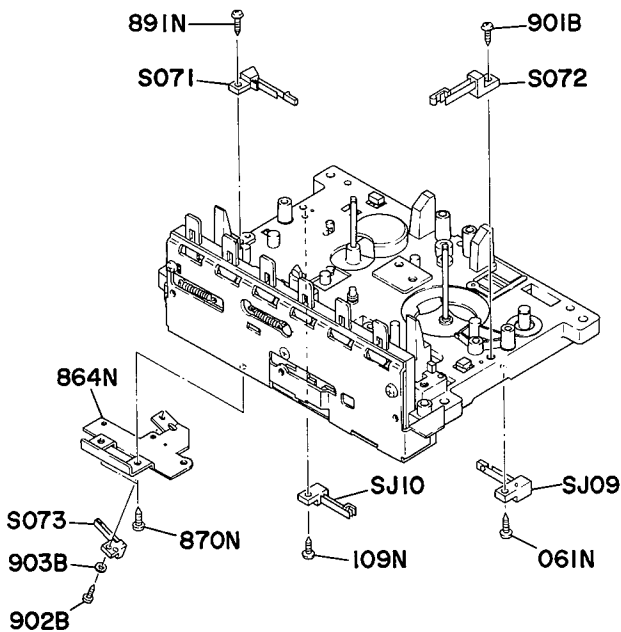

REF. DESIG.	Q'TY				PART NO.	DESCRIPTION
	U	C	N	A		
901B	1	1	1	1	51382308P0	B.H.M. Screw B2 x 5
902B	1	1	1	1	51100205A0	B.H.M. Screw B2 x 5
903B	1	1	1	1	54020201E0	Flat Washer, P.
061N	1	1	1	1	51060204A0	P.H.M. Screw P2 x 4
109N	1	1	1	1	51302608B0	P.H. Tapped Screw P2.6 x 8
864N	1	1	1	1	307Y160080	Bracket
870N	2	2	2	2	51572604A0	P. Taptite Screw P2.6 x 4
891N	1	1	1	1	51302608B0	P.H. Tapped Screw P2.6 x 8
S071	1	1	1	1	SM01010930	Mini Switch, Muting
S072	1	1	1	1	SM01010900	Mini Switch, Pause
S073	1	1	1	1	SM01010910	Mini Switch, Rec
SJ09	1	1	1	1	SM01010850	Mini Switch, Starter
SJ10	1	1	1	1	SM01010870	Mini Switch, Motor

8.7 [P05-99] PARTS ASSEMBLED ON TOP OF CHASSIS

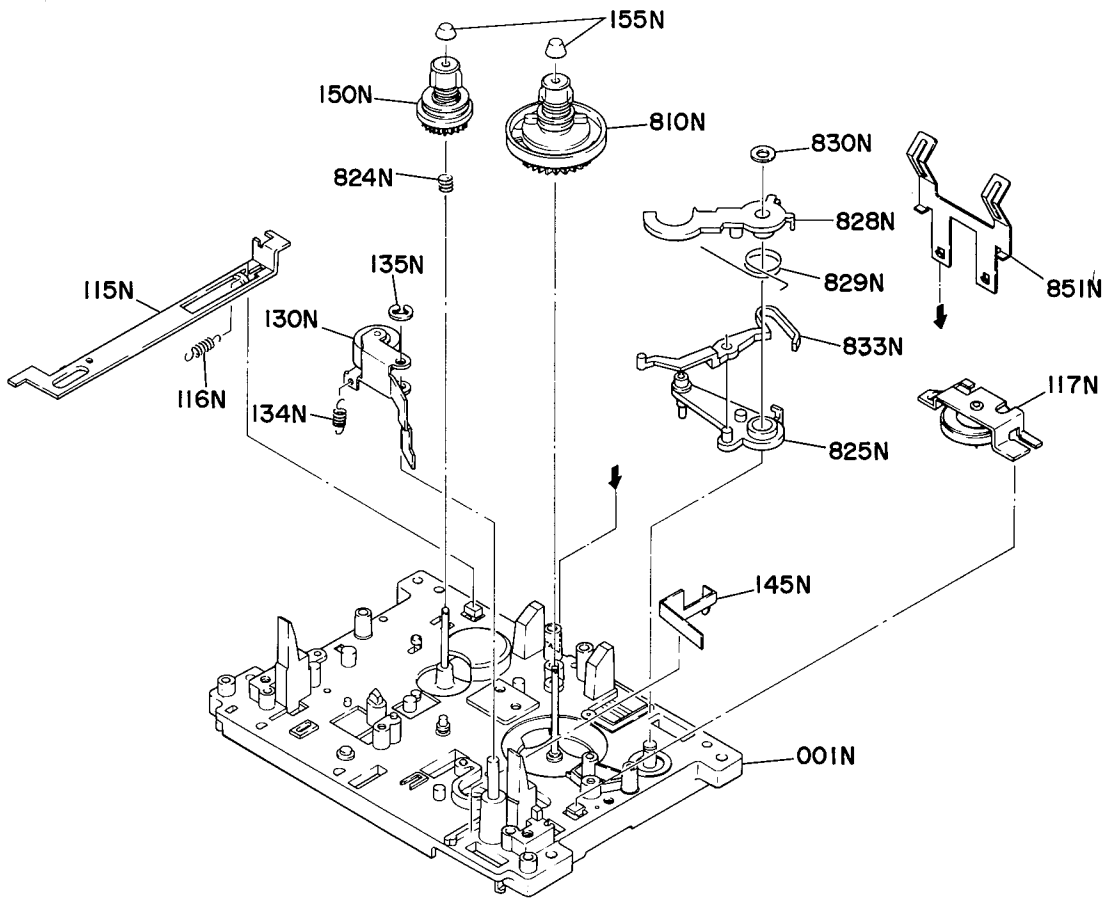

REF. DESIG.	Q'TY				PART NO.	DESCRIPTION
	U	C	N	A		
001N	1	1	1	1	307Y105400	Chassis Assembly, Main
115N	1	1	1	1	307Y354080	Lever, Rec Safety
116N	1	1	1	1	307Y115140	Spring
117N	1	1	1	1	307Y354410	Lever Assembly, Take-up
130N	1	1	1	1	307Y002410	Arm Assembly, Pinch Roller
134N	1	1	1	1	307Y115100	Spring
135N	1	1	1	1	64002500R0	RG Ring, E Type
145N	1	1	1	1	307Y115040	Spring
150N	1	1	1	1	307Y004400	Table Assembly, Supply
155N	2	2	2	2	4367067010	Cap

REF. DESIG.	Q'TY				PART NO.	DESCRIPTION
	U	C	N	A		
810N	1	1	1	1	307Y004410	Table Assembly, Tape-up
824N	1	1	1	1	307Y115250	Spring
825N	1	1	1	1	307Y002420	Arm Assembly, TMS
828N	1	1	1	1	307Y002060	Arm, TMS Sensor
829N	1	1	1	1	307Y115070	Spring
830N	1	1	1	1	307Y114020	Stopper
833N	1	1	1	1	307Y002210	Arm, TMS
851N	1	1	1	1	307Y115020	Spring, Cassette

8.8 [P06-99] PARTS ASSEMBLED ON REVERSE OF CHASSIS

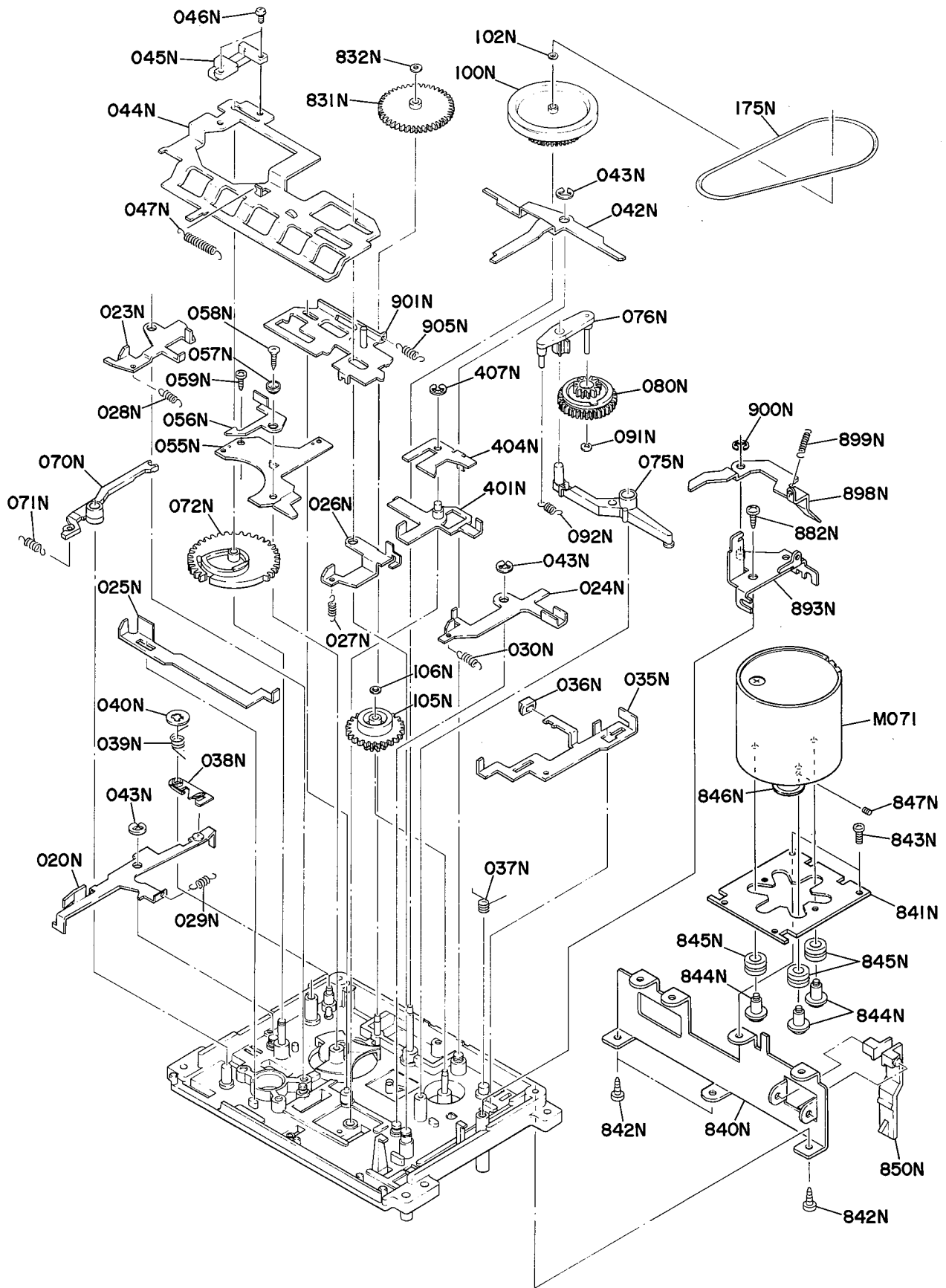

REF. DESIG.	Q'TY				PART NO.	DESCRIPTION
	U	C	N	A		
020N	1	1	1	1	307Y354400	Lever Assembly, Pause
023N	1	1	1	1	307Y354020	Lever, FF
024N	1	1	1	1	307Y354030	Lever, REW
025N	1	1	1	1	307Y354050	Lever, Stop
026N	1	1	1	1	307Y354040	Lever, Rec
027N	1	1	1	1	307Y115210	Spring
028N	1	1	1	1	307Y115240	Spring
029N	1	1	1	1	307Y115240	Spring
030N	1	1	1	1	307Y115160	Spring
035N	1	1	1	1	307Y354070	Lever, Brake
036N	1	1	1	1	4367263010	Brake
037N	1	1	1	1	307Y115090	Spring
038N	1	1	1	1	307Y054040	Cam, Pause Lock
039N	1	1	1	1	307Y115080	Spring
040N	1	1	1	1	64020300Q0	RG Ring, CS Type
042N	1	1	1	1	307Y002240	Arm
043N	3	3	3	3	64000300R0	RG Ring, E Type
044N	1	1	1	1	307Y127010	Control Board
045N	1	1	1	1	307Y114010	Stopper
046N	2	2	2	2	51062604A0	P.H.M. Screw P2.6 x 4
047N	1	1	1	1	307Y115150	Spring
055N	1	1	1	1	307Y160030	Bracket, Starter SW.
056N	1	1	1	1	307Y002110	Arm
057N	1	1	1	1	307Y259010	Bushing
058N	1	1	1	1	51302608B0	P.H.M. Screw P2.6 x 8
059N	1	1	1	1	51302608B0	P.H.M. Screw P2.6 x 8
070N	1	1	1	1	307Y002030	Arm
071N	1	1	1	1	307Y115140	Spring
072N	1	1	1	1	307Y058050	Gear, Drive
075N	1	1	1	1	307Y002080	Arm, REW
076N	1	1	1	1	307Y002400	Arm Assembly, FF/REW
080N	1	1	1	1	307Y058400	Gear Assembly
091N	1	1	1	1	64001500R0	RG Ring, E Type
092N	1	1	1	1	307Y115200	Spring
100N	1	1	1	1	307Y262020	Pulley
102N	1	1	1	1	307Y118010	Spacer
105N	1	1	1	1	307Y058040	Gear, REW
106N	1	1	1	1	307Y118010	Spacer
175N	1	1	1	1	307Y264020	Belt
401N	1	1	1	1	307Y354420	Lever Assembly, Play
404N	1	1	1	1	307Y354100	Lever, Brake
405N	1	1	1	1	307Y114030	Stopper
407N	1	1	1	1	64002500R0	RG Ring, E Type
831N	1	1	1	1	307Y058060	Gear, TMS

REF. DESIG.	Q'TY				PART NO.	DESCRIPTION
	U	C	N	A		
832N	1	1	1	1	307Y118010	Spacer
840N	1	1	1	1	307Y160040	Bracket
841N	1	1	1	1	307Y160050	Bracket, Motor
842N	3	3	3	3	51300308B0	P.H. Tapped Screw P3 x 8
843N	2	2	2	2	51572604A0	P. Taptite Screw P2.6 x 4
844N	3	3	3	3	4367112150	Shaft
845N	3	3	3	3	4383259010	Bushing
846N	1	1	1	1	307Y262050	Pulley, Motor
847N	1	1	1	1	51690305Q9	Socket Screw, HP M3 x 5
850N	1	1	1	1	307Y002090	Arm, Rec Safety
882N	1	1	1	1	51300308B0	P.H. Tapped Screw P3 x 8
893N	1	1	1	1	307Y104400	Retainer Assembly
898N	1	1	1	1	307Y002190	Arm
899N	1	1	1	1	307Y115140	Spring
900N	1	1	1	1	64002500R0	RG Ring, E Type
901N	1	1	1	1	307Y054400	Cam Assembly, Lock
905N	1	1	1	1	4367115120	Spring
M071	1	1	1	1	MM11200170	D.C. Motor, Governor 2200rpm

8.9 [H01-99] PACKING MATERIALS

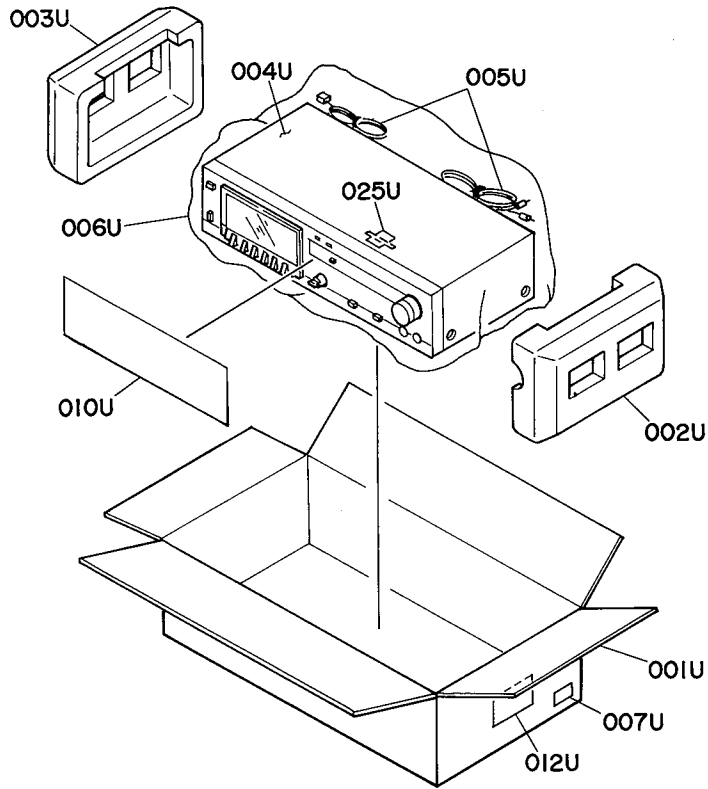

REF. DESIG.	Q'TY				PART NO.	DESCRIPTION
	U	C	N	A		
001U	1	1	1	1	131T801010	Packing Case
002U	1	1	1	1	124T809010	Cushion, (R)
003U	1	1	1	1	124T809020	Cushion, (L)
004U	1	1	1	1	2918107360	Sheet, Top Cover
005U	2	2	2	2	402P005040	Clamper
006U	1	1	1	1	9090909030	Polyethylene Sheet
007U	4				9526019010	Serial No. Card
007U		4			9526019020	Serial No. Card
007U			4		9526019060	Serial No. Card
007U				4	9526019030	Serial No. Card

REF. DESIG.	Q'TY				PART NO.	DESCRIPTION
	U	C	N	A		
010U	1	1	1	1	124T807010	Reinforcing Label, Address
012U		2			9510901020	Label, Address
025U			1		2731821010	Silicagel

REF. DESIG.	Q'TY				PART NO.	DESCRIPTION
	U	C	N	A		
CL01	1	1	1	1	DF15221550	Film 220p F ±5%
CL02	1	1	1	1	DF15221550	Film 220p F ±5%
CL03	1	1	1	1	DF15104550	Film 0.1μ F ±5%
CL04	1	1	1	1	DF15223550	Film 0.022μ F ±5%
CL05	1	1	1	1	DF15103350	Film 0.01μ F ±5%
CL06	1	1	1	1	EA22701630	Elect 220μ F 16V
CU01	1	1	1	1	EA33505030	Elect 3.3μ F 50V
CU02	1	1	1	1	EA47701630	Elect 470μ F 16V
CU03	1	1	1	1	EA22701630	Elect 220μ F 16V
CU21	1	1	1	1	DK18103300	Ceramic 0.01μ F
CX03	1	1	1	1	EA10505030	Elect 1μ F 50V
CX04	1	1	1	1	EA10505030	Elect 1μ F 50V
PJ01-RESISTORS (All Resistors are ±5% & 1/4W)						
R601	1	1	1	1	GD05274140	270KΩ
R602	1	1	1	1	GD05274140	270KΩ
R603	1	1	1	1	GD05184140	180KΩ
R604	1	1	1	1	GD05184140	180KΩ
R605	1	1	1	1	GD05473140	47KΩ
R606	1	1	1	1	GD05473140	47KΩ
R607	1	1	1	1	GD05332140	3.3KΩ
R608	1	1	1	1	GD05332140	3.3KΩ
R609	1	1	1	1	GD05181140	180Ω
R610	1	1	1	1	GD05181140	180Ω
R611	1	1	1	1	GD05102140	1KΩ
R612	1	1	1	1	GD05102140	1KΩ
R811	1	1	1	1	GA05100010	10Ω 1W
△R812	1	1	1	1	GG05101140	100Ω
△R813	1	1	1	1	GG05471120	470Ω 1/4W
△R814	1	1	1	1	GA05010010	1Ω 1W
RG01	1	1	1	1	GD05682140	6.8KΩ
RG02	1	1	1	1	GD05682140	6.8KΩ
RG03	1	1	1	1	GD05682140	6.8KΩ
RG04	1	1	1	1	GD05682140	6.8KΩ
RG05	1	1	1	1	GD05123140	12KΩ
RG06	1	1	1	1	GD05123140	12KΩ
RG07	1	1	1	1	GD05153140	15KΩ
RG08	1	1	1	1	GD05153140	15KΩ
RG09	1	1	1	1	GD05474140	470KΩ
RG10	1	1	1	1	GD05474140	470KΩ
RG11	1	1	1	1	GD05472140	4.7KΩ
RG12	1	1	1	1	GD05472140	4.7KΩ
RG13	1	1	1	1	GD05274140	270KΩ
RG14	1	1	1	1	GD05274140	270KΩ
RG15	1	1	1	1	GD05682140	6.8KΩ
RG16	1	1	1	1	GD05682140	6.8KΩ
RG17	1	1	1	1	GD05153140	15KΩ
RG18	1	1	1	1	GD05153140	15KΩ
RG19	1	1	1	1	GD05273140	27KΩ
RG20	1	1	1	1	GD05273140	27KΩ

REF. DESIG.	Q'TY				PART NO.	DESCRIPTION
	U	C	N	A		
RG23	1	1	1	1	GD05332140	3.3KΩ
RG24	1	1	1	1	GD05332140	3.3KΩ
RG25	1	1	1	1	GD05333140	33KΩ
RG26	1	1	1	1	GD05333140	33KΩ
RG27	1	1	1	1	GD05221140	220Ω
RG28	1	1	1	1	GD05221140	220Ω
RG29	1	1	1	1	GD05184140	180KΩ
RG31	1	1	1	1	GD05125140	1.2MΩ
RG33	1	1	1	1	GD05471140	470Ω
RG34	1	1	1	1	GD05471140	470Ω
RJ01	1	1	1	1	GD05100140	10Ω
RJ02	1	1	1	1	GD05100140	10Ω
RJ03	1	1	1	1	GD05104140	100KΩ
RJ04	1	1	1	1	GD05104140	100KΩ
RJ05	1	1	1	1	GD05103140	10KΩ
RJ06	1	1	1	1	GD05103140	10KΩ
RJ07	1	1	1	1	GD05272140	2.7KΩ
RJ08	1	1	1	1	GD05272140	2.7KΩ
RJ09	1	1	1	1	GD05820140	82Ω
RJ10	1	1	1	1	GD05820140	82Ω
RJ11	1	1	1	1	GD05473140	47KΩ
RJ12	1	1	1	1	GD05473140	47KΩ
RJ13	1	1	1	1	GD05394140	390KΩ
RJ14	1	1	1	1	GD05394140	390KΩ
RJ17	1	1	1	1	GD05102140	1KΩ
RJ18	1	1	1	1	GD05102140	1KΩ
RJ19	1	1	1	1	GD05682140	6.8KΩ
RJ20	1	1	1	1	GD05682140	6.8KΩ
RJ21	1	1	1	1	GD05822140	8.2KΩ
RJ22	1	1	1	1	GD05822140	8.2KΩ
RJ23	1	1	1	1	GD05184140	180KΩ
RJ24	1	1	1	1	GD05184140	180KΩ
RJ25	1	1	1	1	GD05332140	3.3KΩ
RJ26	1	1	1	1	GD05332140	3.3KΩ
RJ27	1	1	1	1	GD05392140	3.9KΩ
RJ28	1	1	1	1	GD05392140	2.9KΩ
RJ29	1	1	1	1	GD05224140	220KΩ
RJ30	1	1	1	1	GD05224140	220KΩ
RJ31	1	1	1	1	RA05030280	50KΩ, Trimming
RJ32	1	1	1	1	RA05030280	50KΩ, Trimming
RJ33	1	1	1	1	GD05153140	15KΩ
RJ34	1	1	1	1	GD05153140	15KΩ
RJ35	1	1	1	1	GD05333140	33KΩ
RJ43	1	1	1	1	GD05473140	47KΩ
RJ44	1	1	1	1	GD05473140	47KΩ
RJ45	1	1	1	1	GD05472140	4.7KΩ
RJ46	1	1	1	1	GD05472140	4.7KΩ
RJ47	1	1	1	1	GD05125140	1.2MΩ
RJ48	1	1	1	1	GD05125140	1.2MΩ
RJ49	1	1	1	1	GD05472140	4.7KΩ
RJ50	1	1	1	1	GD05472140	4.7KΩ
RJ51	1	1	1	1	GD05473140	47KΩ
RJ52	1	1	1	1	GD05473140	47KΩ
RJ53	1	1	1	1	GG05271120	270Ω 1/4W
RJ55	1	1	1	1	GD05333140	33KΩ
RJ56	1	1	1	1	GD05333140	33KΩ

REF. DESIG.	Q'TY				PART NO.	DESCRIPTION
	U	C	N	A		
RK01	1	1	1	1	GD05123140	12K Ω
RK02	1	1	1	1	GD05123140	12K Ω
RK03	1	1	1	1	GD05683140	68K Ω
RK04	1	1	1	1	GD05683140	68K Ω
RK05	1	1	1	1	GD05183140	18K Ω
RK06	1	1	1	1	GD05183140	18K Ω
RK07	1	1	1	1	GD05331140	330 Ω
RK08	1	1	1	1	GD05331140	330 Ω
RK11	1	1	1	1	GD05563140	56K Ω
RK12	1	1	1	1	GD05563140	56K Ω
RK13	1	1	1	1	GD05123140	12K Ω
RK14	1	1	1	1	GD05123140	12K Ω
RK15	1	1	1	1	GD05562140	5.6K Ω
RK16	1	1	1	1	GD05562140	5.6K Ω
RK17	1	1	1	1	GD05153140	15K Ω
RK18	1	1	1	1	GD05153140	15K Ω
RK19	1	1	1	1	GD05472140	4.7K Ω
RK20	1	1	1	1	GD05472140	4.7K Ω
RK21	1	1	1	1	GD05682140	6.8K Ω
RK22	1	1	1	1	GD05682140	6.8K Ω
RK23	1	1	1	1	GD05332140	3.3K Ω
RK24	1	1	1	1	GD05332140	3.3K Ω
RK27	1	1	1	1	RA02030170	20K Ω , Trimming
RK28	1	1	1	1	RA02030170	20K Ω , Trimming
RK29	1	1	1	1	GD05472140	4.7K Ω
RK30	1	1	1	1	GD05472140	4.7K Ω
RK31	1	1	1	1	GD05472140	4.7K Ω
RK32	1	1	1	1	GD05472140	4.7K Ω
RK33	1	1	1	1	GD05153140	15K Ω
RK34	1	1	1	1	GD05153140	15K Ω
RL01	1	1	1	1	RA05030800	50K Ω , Trimming
RL02	1	1	1	1	RA05030800	50K Ω , Trimming
RL03	1	1	1	1	GD05273140	27K Ω
RL04	1	1	1	1	GD05681140	680 Ω
△RL05	1	1	1	1	GG05100140	10 Ω
△RL06	1	1	1	1	GA05151010	15 Ω 1W
△RL07	1	1	1	1	GA05221010	220 Ω 1W
△RL08	1	1	1	1	GA05100010	10 Ω 1W
RU01	1	1	1	1	GD05103140	10K Ω
RU02	1	1	1	1	GD05393140	39K Ω
RU03	1	1	1	1	GD05103140	10K Ω
RU04	1	1	1	1	GD05124140	120K Ω
RU05	1	1	1	1	GD05273140	27K Ω
RU06	1	1	1	1	GD05273140	27K Ω
RU08	1	1	1	1	GD05104140	100K Ω
RU09	1	1	1	1	GD05473140	47K Ω
RU10	1	1	1	1	GD05122140	1.2K Ω
RU11	1	1	1	1	GD05123140	12K Ω
RU12	1	1	1	1	GD05182140	1.8K Ω
RU13	1	1	1	1	GD05393140	39K Ω
RU14	1	1	1	1	GD05123140	12K Ω
RU15	1	1	1	1	GD05102140	1K Ω
RU16	1	1	1	1	GD05473140	47K Ω

REF. DESIG.	Q'TY				PART NO.	DESCRIPTION
	U	C	N	A		
RX05	1	1	1	1	RA02030800	20K Ω , Trimming
RX06	1	1	1	1	RA02030800	20K Ω , Trimming
RX11	1	1	1	1	GD05682140	6.8K Ω
RX12	1	1	1	1	GD05682140	6.8K Ω
RX13	1	1	1	1	GD05153140	15K Ω
RX14	1	1	1	1	GD05153140	15K Ω
RY01	1	1	1	1	GD05152140	1.5K Ω
RY02	1	1	1	1	GD05152140	1.5K Ω
PJ01-SEMICONDUCTORS						
△D801	1	1	1	1	HD20015030	Diode DS136D
△D802	1	1	1	1	HD20015030	Diode DS135D
△D803	1	1	1	1	HD20015030	Diode DS135D
△D804	1	1	1	1	HD20015030	Diode DS135D
D811	1	1	1	1	HD30087090	Zener BZ-130
DG01	1	1	1	1	HD20011050	Diode 1S1555
DG02	1	1	1	1	HD20011050	Diode 1S1555
DG03	1	1	1	1	HD20011050	Diode 1S1555
DG04	1	1	1	1	HD20011050	Diode 1S1555
DG05	1	1	1	1	HD20011050	Diode 1S1555
DJ01	1	1	1	1	HD20011050	Diode 1S1555
DJ02	1	1	1	1	HD20011050	Diode 1S1555
DU01	1	1	1	1	HD20011550	Diode 1S1555
DU02	1	1	1	1	HD20011050	Diode 1S1555
DU03	1	1	1	1	HD20011050	Diode 1S1555
DU04	1	1	1	1	HD20011050	Diode 1S1555
DU05	1	1	1	1	HD30052090	Zener WZ-056
DU06	1	1	1	1	HD30052090	Zener WZ-056
Q001	1	1	1	1	HC10010270	IC NE646BCC3727
Q002	1	1	1	1	HC10010270	IC NE646BCC3727
Q003	1	1	1	1	HC10003090	IC NJM4558D
Q005	1	1	1	1	HC406600B0	IC 4066
Q006	1	1	1	1	HC406905B0	IC TC4069UBP
Q811	1	1	1	1	HT403131E0	Transistor 2SD313 (E)
QG01	1	1	1	1	HT308282A0	Transistor 2SC828 (R or S)
QG02	1	1	1	1	HT308282A0	Transistor 2SC828 (R or S)
QG03	1	1	1	1	HT326341S0	Transistor 23C3634 (S)
QG04	1	1	1	1	HT326341S0	Transistor 2SC2634 (S)

REF. DESIG.	Q'TY				PART NO.	DESCRIPTION
	U	C	N	A		
QJ01	1	1	1	1	HT326342A0	Transistor 2SC2634 (R or S)
QJ02	1	1	1	1	HT326342A0	Transistor 2SC2634 (R or S)
QJ03	1	1	1	1	HT326342A0	Transistor 2SC2634 (R or S)
QJ04	1	1	1	1	HT326342A0	Transistor 2SC2634 (R or S)
QJ05	1	1	1	1	HT318452B0	Transistor 2SC1845 (F or E)
QJ06	1	1	1	1	HT318452B0	Transistor 2SC1845 (F or E)
QJ07	1	1	1	1	HT323622A0	Transistor 2SC2362 (F or G)
QJ08	1	1	1	1	HT323622A0	Transistor 2SC2362 (F or G)
QJ09	1	1	1	1	HT323622A0	Transistor 2SC2362 (F or G)
QJ10	1	1	1	1	HT323622A0	Transistor 2SC2362 (F or G)
QJ11	1	1	1	1	HT318452B0	Transistor 2SC1845 (F or E)
QJ12	1	1	1	1	HT318452B0	Transistor 2SC1845 (F or E)
QK01	1	1	1	1	HT323622A0	Transistor 2SC2362 (F or G)
QK02	1	1	1	1	HT323622A0	Transistor 2SC2362 (F or G)
QL01	1	1	1	1	HT313841R0	Transistor 2SC1384 (R)
QU01	1	1	1	1	HT308282A0	Transistor 2SC828 (R or S)
QU02	1	1	1	1	HT107332A0	Transistor 2SA733 (P or Q)
QU03	1	1	1	1	HT107332A0	Transistor 2SA733 (P or Q)
QU04	1	1	1	1	HT107332A0	Transistor 2SA733 (P or Q)
QU05	1	1	1	1	HT107332A0	Transistor 2SA733 (P or Q)
QU06	1	1	1	1	HT308282A0	Transistor 2SA828 (R or S)
J811	1	1	1	1	YP06001060	PJ01-MISCELLANEOUS Plug, (7P)
JJ01	1	1	1	1	YJ01001780	Jack, Mic (L)
JJ02	1	1	1	1	YJ01001780	Jack, Mic (R)
JJ05	1	1	1	1	YP06002420	Plug, (6P)
JX01	1	1	1	1	YJ06002440	Jack, (4P)
PJ72	1	1	1	1	YP06002360	Plug, (3P)
L601	1	1	1	1	LS10440020	M.P.X. Coil
L602	1	1	1	1	LS10440020	M.P.X. Coil
LK01	1	1	1	1	LC22260600	Choke Coil, 22mH
LK02	1	1	1	1	LC22260600	Choke Coil, 22mH
LK03	1	1	1	1	LC21060510	Choke Coil, 10mH
LK04	1	1	1	1	LC21060510	Choke Coil, 10mH
LL01	1	1	1	1	TC10440020	OSC Transformer
S101	1	1	1	1	SP02010630	Push Switch, Mic/Line
S102	1	1	1	1	SR04030320	Rotary Switch, Tape Select
S103	1	1	1	1	SP02010630	Push Switch, Dolby
PW01	1	1	1	1	YK124T1420	PW01-REC VOLUME CIRCUIT BOARD P.W. Board, Rec Volume
	1	1	1	1	ZZ124T1420	P.W. Board Assembly
CU20	1	1	1	1	DK18103300	Ceramic Cap. 0.01 μ F
RJ54	1	1	1	1	RD05030120	Variable Resistor 50K Ω
JW03	1	1	1	1	YU05180260	Jumper Lead, (5P)

REF. DESIG.	Q'TY				PART NO.	DESCRIPTION
	U	C	N	A		
PY01	1	1	1	1	YK124T1430	PY01-MECHA L.E.D. CIRCUIT BOARD P.W. Board, Mecha L.E.D.
	1	1	1	1	ZZ131T1430	P.W. Board Assembly
QY01	1	1	1	1	HI10030020	L.E.D. LN224RP, Rec
QY02	1	1	1	1	HI10030020	L.E.D. LN224RP, Pause
PY21	1	1	1	1	YU03200260	Jumper Lead, (3P) 200 mm
PX01	1	1	1	1	HI10801320	L.E.D. Meter
CX91	1	1	1	1	EA47503530	Elect Cap 4.7 μ F 35V
CX92	1	1	1	1	EA47503530	Elect Cap 4.7 μ F 35V
CX93	1	1	1	1	EA10505030	Elect Cap 1 μ F 50V
CX94	1	1	1	1	EA10505030	Elect Cap 1 μ F 50V
CX95	1	1	1	1	EA10601630	Elect Cap 10 μ F 16V
RX91	1	1	1	1	GD05472140	Resistor 4.7K Ω \pm 5% $\frac{1}{4}$ W
RX92	1	1	1	1	GD05472140	Resistor 4.7K Ω \pm 5% $\frac{1}{4}$ W
RX93	1	1	1	1	GD05621140	Resistor 620 Ω \pm 5% $\frac{1}{4}$ W

(W01-99)	Assembly and Wiring
(T01-99)	Adjustment
(X01-00)	Correction

NOTE ON SAFETY:
 SYMBOL Δ FIRE OR ELECTRICAL SHOCK HAZARD. ONLY ORIGINAL PARTS SHOULD BE USED TO REPLACE ANY PART MARKED WITH SYMBOL Δ . ANY OTHER COMPONENT SUBSTITUTION (OTHER THAN ORIGINAL TYPE), MAY INCREASE RISK OF FIRE OR ELECTRICAL SHOCK HAZARD.

9. TECHNICAL SPECIFICATIONS

Style	Front load
Tape Drive System	Single Capstan Drive
Cartridge	Philips type compact cassette
Track System	Compatible Stereo 4-track 2-channel
Tape Speed	4.75 cm/sec.
Heads	2 Head System
Composition	Rec/Play: Super Hard Metal Alloy
	Erase: Dual gap Ferrite
Motor	1 Motor System
	Capstan DC Servo Motor
Meters	8 Dots Peak LED Meter x 2
Overall Frequency Response at -20 dB	
Normal Tape	30 Hz ~ 15 kHz
CrO ₂ Tape	30 Hz ~ 16 kHz
Metal Tape	30 Hz ~ 17.5 kHz
Signal-to-Noise Ratio:	
Dolby (ON)	66 dB
Dolby (OFF)	56 dB
Wow and Flutter	
DIN WTD	0.13%
Outputs	
Line Level/Impedance	500 mV/5 kΩ
Input (Level at 0 VU)	
Line Sensitivity/Impedance	50 mV/50 kΩ
Mic Sensitivity/Impedance	0.25 mV/10 kΩ
Fast Rewind Time	90 sec. (C-60)
Fast Forward Time	90 sec. (C-60)
Power Consumption	17 V 9 W
Dimensions (W x H x D)	416 x 100 x 194 mm
Weight	2.7 kg

Specifications and appearance are subject to change for modification without notice.

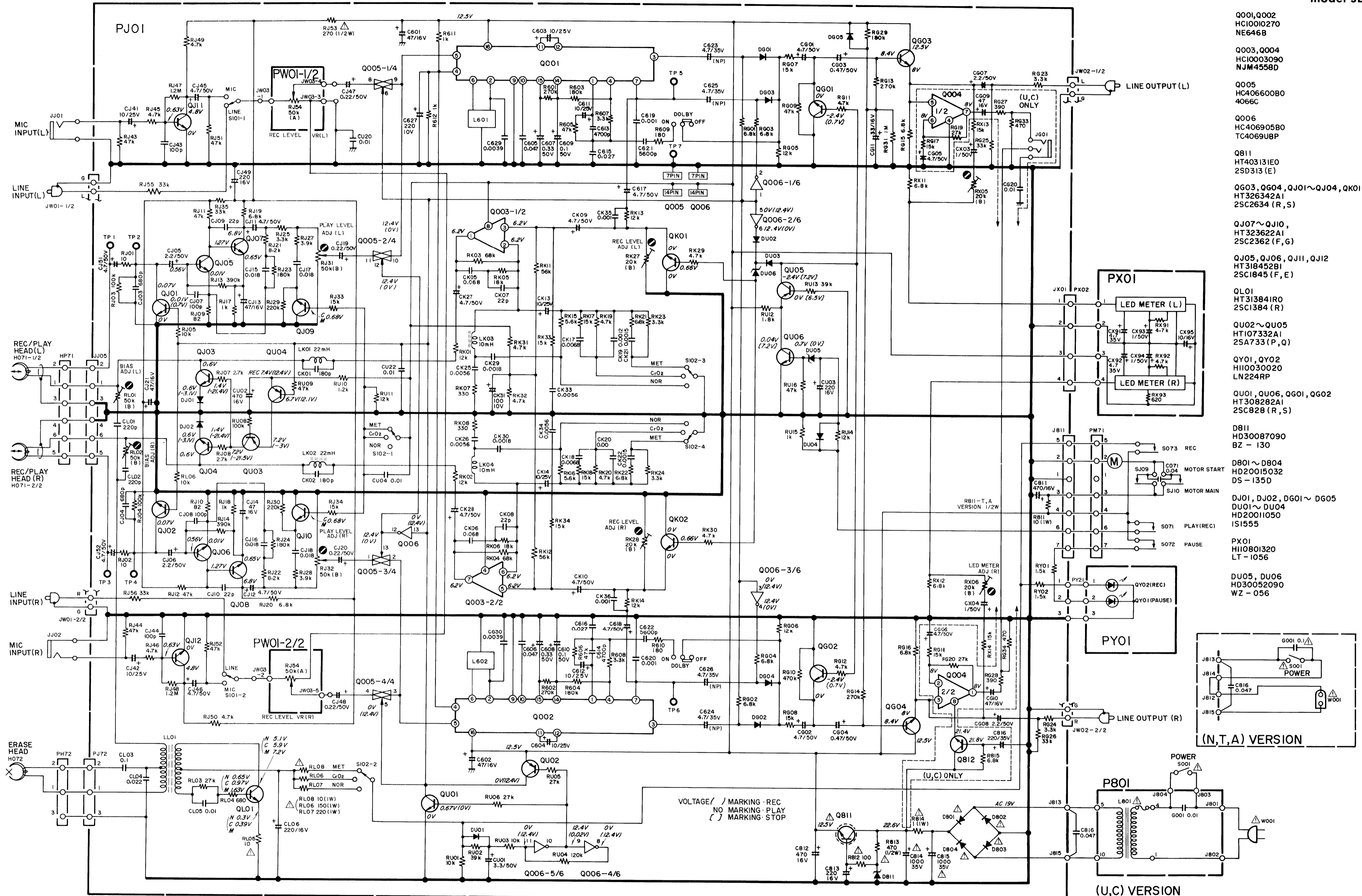

- Q001, Q002
HC10010270
NE646B
- Q003, Q004
HC1003090
NJM4558D
- Q005
HC406600B0
4066C
- Q006
HC406905B0
TC4069UBP
- Q811
HT40313IE0
2SD313 (E)
- Q603, Q604, QJ01~QJ04, QK01, QK02
HT326342A1
25C2634 (R, S)
- QJ07~QJ10,
HT318452B1
25C2362 (F, G)
- QJ05, QJ06, QJ11, QJ12
HT318452B1
25C1845 (F, E)
- QL01
HT313841R0
25C1384 (R)
- QU02~QU05
HT107332A1
25A733 (P, Q)
- QY01, QY02
HI10030020
LN224RP
- QU01, QU06, QG01, QG02
HT308282A1
25C828 (R, S)
- D811
HD30087090
BZ - 130
- D801~D804
HD20015032
DS - 135D
- DJ01, DJ02, DG01~DG05
DU01~DU04
HD20011050
IS1555
- PX01
HI10801320
LT - 1056
- DU05, DU06
HD30052090
WZ - 056

VOLTAGE / MARKING - REC
NO MARKING - PLAY
() MARKING - STOP

Components and wiring are subject to change for modification without notice.

(U,C) VERSION
NOTE ON SAFETY:
SYMBOL FIRE OR ELECTRICAL SHOCK HAZARD. ONLY ORIGINAL PARTS SHOULD BE USED TO REPLACE ANY PART MARKED WITH SYMBOL . ANY OTHER COMPONENT SUBSTITUTION (OTHER THAN ORIGINAL TYPE), MAY INCREASE RISK OF FIRE OR ELECTRICAL SHOCK HAZARD.



marantz®

Noise Reduction System manufactured under license from Dolby Laboratories.
"DOLBY", the Double-D symbol and the word "Dolbyized" are trademarks of Dolby Laboratories.
MARANTZ is a registered trademark