

**SERVICE
MANUAL**

SD4000

marantz[®]

model SD4000

Stereo Cassette Deck

MARANTZ DESIGN AND SERVICE

Using superior design and selected high grade components, MARANTZ Company has created the ultimate in stereo sound. Only original MARANTZ parts can insure that your MARANTZ product will continue to perform to the specifications for which it is famous.

Parts for your MARANTZ stereo are generally available within 72 hours throughout the nation via a toll-free line to our National Parts Depot in California. The sales professionals who take your call immediately refer to their own desk top computer terminal and can quickly determine the availability and price information you require. If, for some reason, your order should exceed our available stock, we usually can instantly provide an alternate replacement part or current delivery information. When the order is placed and confirmed, the computer simultaneously generates "hard copy" orders at the distribution center. As hard copies come directly from the computer to the national parts depot, your requested stock is assembled and prepared for shipment and placed on the first available carrier for delivery to you.

ORDERING PARTS

Phone orders will eliminate mail delays, and we encourage the use of this method. If you order by mail, use MARANTZ parts order forms which are available from our National Parts Depot located at the following address:

SUPERSCOPE NATIONAL PARTS DEPARTMENT
20525 Nordhoff Street
Chatsworth, California 91311
Phone: 1-800-423-5108
1-213-998-9333

The following information must be supplied to eliminate delays in processing your order:

1. Complete address.
2. Complete part numbers.
3. Complete description of parts.
4. Model number for which part is required (indicate MARANTZ).
5. Account number (for account customers only).

Direct consumers will be provided with the current retail price quotation on available parts in order to advise them of the cost of the parts and shipping.

OVERSEAS PARTS ORDERING

Parts may also be ordered from the following overseas addresses:

CANADA

Superscope Canada, Ltd.
3710 Nashua Drive
Mississauga
Ontario, Canada L4V1M5

AUSTRALIA

Superscope (Australasia) Pty., Ltd.
32 Cross Street (P.O. Box 604)
Brookvale 2100 N.S.W.
Australia

JAPAN

Marantz Japan, Inc.
3622 Kamitsuruma
Sagamihara Shi
Kanagawa, Japan

EUROPE

Superscope Europe, S.A.
Avenue Leopold III, 2
7 120 Peronnes-Lez-Binche
Belgium

Marantz France
Rue Louis Armand 9
92600 Asnieres
Hauts-de-Seine
France

Marantz Audio U.K. Ltd.
London Road, 203
Staines
Middlesex
England

Superscope GmbH
Max-Planck-Strasse 2 2
D-6072 Dreieich 1
West Germany

All of the above locations are fully equipped to take care of your total service needs. Because various countries have differing configuration requirements, it is necessary that you contact the service facility in your particular country. In the event that there is no service location listed for your country, please contact the nearest facility for the necessary assistance.

TABLE OF CONTENTS

Section	Title	Page
1.	P.W. BOARD	3
2.	TEST EQUIPMENT REQUIRED FOR SERVICING	3
3.	CIRCUIT DESCRIPTION	4
3.1	Tape Speed Selector	4
3.2	Playback Equalizer Circuit	4
3.3	Recording Compensating Circuit	4
3.4	Recording Current Setting Circuit	4
3.5	LED Meter Circuit	5
3.6	Skip Circuit Function	5
3.7	Bias Oscillator Circuit/Erase Oscillator Circuit	5
4.	DISASSEMBLY	6
4.1	Removing the Cassette Case Escutcheon	6
4.2	Removing the Front Panel	6
4.3	Removing the Mechanical Chassis	6
4.4	Removing the Pre Amp P.W. Board	6
5.	MECHANICAL ADJUSTMENTS	7
5.1	Adjusting the Flywheel Thrust	7
5.2	Adjusting the Pause Timing	7
5.3	Adjusting the Pinch Roller Pressure	7
5.4	Adjusting the Play Timing	7
5.5	Adjusting the Play Torque	8
5.6	Adjusting the Fast Forward Rewind Toque	8
5.7	Positioning the Motor Pulley	8
5.8	Adjusting the Rewind Idler Side Pressure	8
5.9	Positioning the Switches	9
6.	ELECTRICAL ADJUSTMENTS	11
6.1	Head Azimuth Adjustment	11
6.2	Tape Speed Adjustment	12
6.3	Playback Equalizer Adjustment	13
6.4	Playback Output Adjustment	13
6.5	LED Peak Level Meter Adjustment	14
6.6	Recording Bias Current Adjustment	14
6.7	Recording Current Adjustment	15
6.8	MPX Filter Adjustment	15
6.9	Record-Playback Frequency Response Adjustment	16
7.	VOLTAGE CONVERSION	17
8.	DIAGRAMS	18
8.1	Block & Level Diagrams	18
8.2	Pre Amp Schematic Diagram and Component Locations-P100 (Solder side)	19
8.3	Fuse Schematic Diagram and Component Locations-P400-For N Version (Solder side)	20
8.4	Compuskip Schematic Diagram and Component Locations-P450 (Solder side)	20
8.5	Dolby Schematic Diagram and Component Locations-P500 (Solder side)	20
8.6	LED Meter Amp Schematic Diagram and Component Locations-P600 (Solder side)	21
8.7	Led Meter Schematic Diagram and Component Locations-P650 (Solder side)	21
8.8	Mic Amp & Volume Schematic Diagram and Component Locations-P700 (Solder side)	22
8.9	Power Supply Schematic Diagram and Component Locations-P900 (Solder side)	22
9.	EXPLODED VIEWS AND PARTS LIST	23
9.1	[P01-99] Front Panel	23
9.2	[P02-99] Front Bracket	24
9.3	[P03-99] Top Cover & Main Chassis	25
9.4	[P04-99] Associated Mechanism for Cassette Tape Operation	26
9.5	[P05-99] Rear Panel	27
9.6	[P05-00] Buttons for Tape Operation	28
9.7	[P06-99] Head Chassis	28
9.8	[P07-99] Flywheel	29
9.9	[P08-99] Switch Location for Tape Operation	29
9.10	[P09-99] Parts Assembled on Top of Chassis	30
9.11	[P10-99] Parts Assembled on Reverse of Chassis	31
9.12	[M01-99] P.W. Board & General Parts	33
9.13	[H01-99] Packing Materials	34
9.14	Electrical Parts	35
10.	TECHNICAL SPECIFICATIONS	42

MARANTZ MODEL SD4000 STEREO CASSETTE DECK



INTRODUCTION

This service manual are prepared for use by Authorized Warranty Station and contains service information for Marantz Stereo Cassette Deck.

Service information and voltage data included in this manual are intended for use by the knowledgeable and experienced technician only. All instructions should be read carefully. No attempt should be made to proceed without a good understanding of the operation of the Cassette Deck.

The parts list furnishes information by which replacement parts may be ordered from the Marantz Company. A simple description is included for parts which can be usually obtained through local suppliers.

1. P.W. BOARDS

As can be seen from the circuit diagram, the chassis of your Cassette Deck consists of the following units. Each unit mounted on a printed circuit board is described within the square enclosed by a bold dotted line on the circuit diagram.

1. Pre Amp mounted on P.W. Board P100
2. Fuse mounted on P.W. Board P400
3. Compuskip. mounted on P.W. board P450
4. Dolby mounted on P.W. Board P500
5. LED Meter Amp mounted on P.W. Board P600
6. LED Meter. mounted on P.W. Board P650
7. Power LED mounted on P700
8. MIC Amp & Vol mounted on P.W. Board P700
9. Power Supply mounted on P.W. Board P900

2. TEST EQUIPMENT REQUIRED FOR SERVICING

For measuring or checking your Cassette Deck, the following instruments and materials are necessary.

- VTVM
- Audio Oscillator (AF OSC)
- Attenuator (600 Ω)
- Oscilloscope
- Bandpass Filter (1 kHz)
- IEC A-Curve Filter
- Wow and Flutter Meter
- Torque Meter (Cassette Type)
- Digital Frequency Counter
- Distortion Meter
- Blank Tapes (Completely erased with bulk eraser)
 - TDK AC-211 (Normal)
 - TDK AC-511 (Special/CrO₂)
 - SONY CS-30 (Fe-Cr)
 - TDK AC701

NOTE: If any doubt is noted in a measured value, use new tape.

- Test Tapes (New Tape)
 - MTT-111 Wow and Flutter, Tape Speed [1-7/8 I.P.S. (4.75 cm/sec)]
 - MTT-111SP Wow and Flutter, Tape Speed [3-3/4 I.P.S. (9.5 cm/sec)]
 - MTT-112 Measurements of Output Level and Signal-to-Noise Ratio
 - MTT-150 Adjustment of Output Level
 - MTT-216 Frequency Response (for Normal)
 - MTT-316 Frequency Response (for CrO₂, Fe-Cr, Metal)
 - MTT-121 Cross Talk
 - MTT-141 Channel Separation

3. CIRCUIT DESCRIPTION

3.1 TAPE SPEED SELECTOR

Tape speed is changed by switching the motor speed to 1,800 rpm for 1-7/8 ips (4.75 cm/sec) or to 3,600 rpm for 3-3/4 ips (9.5 cm/sec). In fast-forward or rewind operation, however, the motor always rotates at 1,800 rpm.

- As shown in the figure below, the motor rotates at 1,800 rpm when R310 (5 kΩ) is shorted by S301 (speed selector) or S090 (FF/REW).
- When R945 is not shorted, the motor rotates at 3,600 rpm.
- R945 is used for precisely adjusting the motor speed to 3,600 rpm.
- To precisely adjust the motor speed to 1,800 rpm, turn the variable resistor built-in the motor.

NOTE: The motor speed is known by playing back the test tape MTT-111 and measuring the reproduced frequency.

Motor speed (rpm)	Reproduced frequency (Hz)
1800	3000
3600	6000

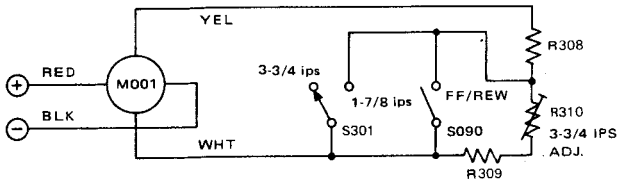

3.2 PLAYBACK EQUALIZER CIRCUIT

A block diagram of the playback equalizer circuit is shown below.

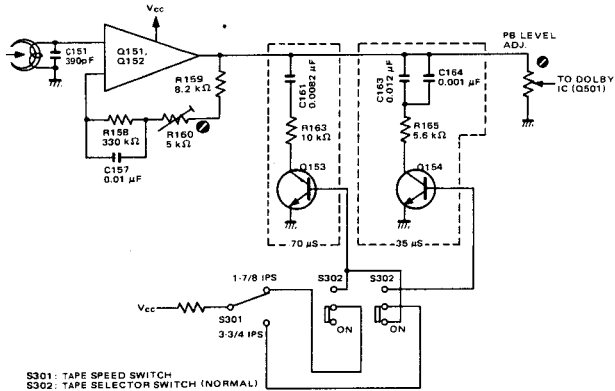

Time constants of the playback equalizer circuit at each tape speed and selector position are as follows:

TAPE SELECTOR POSITION	NORMAL	SPECIAL/ CrO ₂	FeCr	METAL
TAPE SPEED 1-7/8 IPS	120 μS	70 μS	70 μS	70 μS
TAPE SPEED 3-3/4 IPS	70 μS	35 μS	35 μS	35 μS

Circuit Function at Each Time Constant

(1) 120μS

S302 is Tape Selector Switch for normal position. In the diagram, this switch is in the depressed position, causing Q153 and Q154 to turn OFF due to zero bias voltage. In this case, the playback time constant is set to 120μS by C157 and R158~R160.

(2) 70μS

When the tape speed is 1-7/8 ips (4.75 cm/sec) and S302 is OFF (S302 turns OFF when the other tape selector switch is depressed), a bias voltage is applied to the base of Q153 which is then turned ON. When the tape speed is 3-3/4 ips and S302 is ON, Q153 is also ON. In either case, the playback time constant is set to 70μS by C157, R158~R160, C161 and R163.

(3) 35μS

When the tape speed is 3-3/4 ips (9.5 cm/sec) and S302 is OFF, Q154 is ON and the playback time constant is set to 35μS by C157, R158~R160, C163, C164 and R165.

3.3 RECORDING COMPENSATING CIRCUIT

(Tape Speed: 3-3/4 ips)

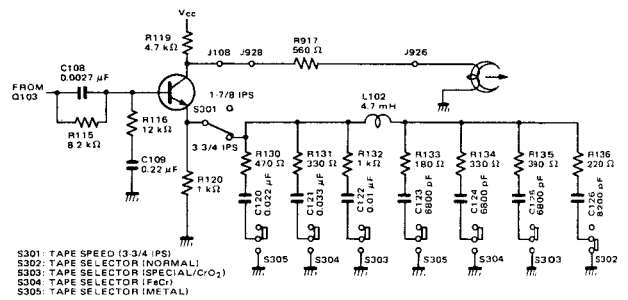

In the circuit diagram, C108 and R115 are used for high range compensation, and R116 and C109 for low range compensation. The compensating circuit for 1-7/8 ips (4.75 cm/sec) tape speed is not shown in the diagram.

L102, R133~R136 and C123~C126 form a peaking circuit. Peaking frequency and the amount of compensation are selected by the tape selector switch.

R130~R132 and C120~C122 are used for medium range compensation. The amount of compensation is selected by the tape selector switch (not available at "Normal" position).

3.4 RECORDING CURRENT SETTING CIRCUIT

Recording currents at each tape speed and each position of the tape selector switch are obtained from the following circuit:

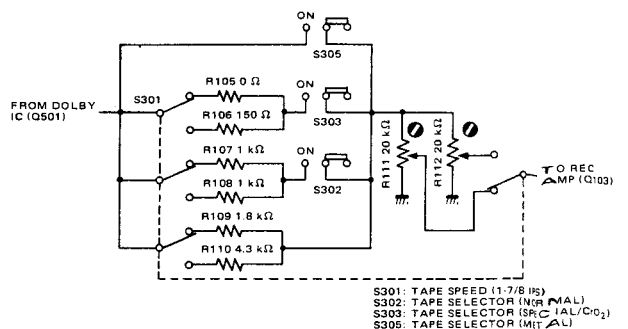

The switch (S304) for the FeCr position is not included in the above circuit. The recording current at this position is determined by R109 and R111 or R110 and R112. The resistors used to determine recording current at each tape speed and each tape selector switch position are

shown in the table below.

TAPE SELECTOR POSITION		NORMAL	SPECIAL/ CrO ₂	FeCr	METAL
TAPE SPEED	1-7/8 IPS	R109, R107 R111	R109, R105 R111	R109 R111	R111
	3-3/4 IPS	R110, R108 R112	R110, R106 R112	R110 R112	R112

3.5 LED METER CIRCUIT

1. The signal amplified and rectified by Q601 and Q602 is applied to the LED drive IC(Q651).
2. The LED drive IC(Q651 makes LEDs light during playback or recording operation.
3. During fast-forward or rewind operation, Q463 is OFF, so that the regulating transistor (Q642) in the LED power supply is OFF.
4. Since Q642 is OFF, noise signals are prevented from lighting LEDs.

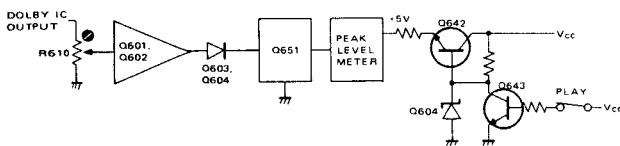

3.6 SKIP CIRCUIT FUNCTION

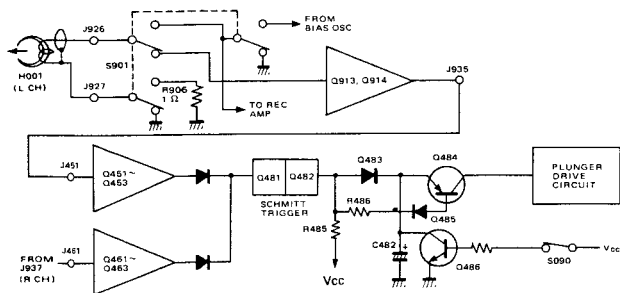

In the above diagram, H001 represents the recording head. During the skip operation, the cassette tape is set in CUE or REVIEW mode, so the gap in the playback head must be in the center of the cassette; otherwise, the head output varies.

In SD4000, a combination head (H001) is employed, which is mounted and tilted toward the right so that the recording head gap is aligned with the center of the cassette. Thus, the recording head is used as a playback head for the skip operation. During the skip operation, the playback output of the recording head is fed to the skip circuit, while the output of the playback head is fed to the playback amplifier as usual. In the recording mode, the recording head functions as a normal recording head through S901. R906 is a resistor to measure the bias current.

Principles of Circuit Operation:

During the skip operation, the playback output of the recording head passes through the flat amplifier (Q913, Q914) and is amplified by Q451~Q453 (this circuit is a narrow band amplifier and protects the skip circuit from misoperation due to playback noise).

The output of Q453 is rectified to DC voltage which turns on Q481 and Q482 off. At this time, C482 is charged through R485 and Q483.

When the input ceases at the blank space between programs, Q481 turns off and Q482 on, while C482 is discharged through Q484, Q485, R486 and Q482. The current discharged flows into the base of Q484 and hence Q484 turns on. The current from C482 also flows into the plunger drive circuit via Q484.

C482 is shorted by Q486 to prevent skip operation during normal playback. Q486 turns off when FF/REW button is pressed. Conversely, when the FF/REW button is released at the end of skip operation, Q486 turns on and thus the output of Q482 remains in the "0" level.

3.7 BIAS OSCILLATOR CIRCUIT/ERASE OSCILLATOR CIRCUIT

The SD4000 has a bias oscillator circuit and an erase oscillator circuit to provide optimum bias and erase current for the use of metal tapes.

- The bias oscillator circuit is driven by a regulated amplifier power supply.
- The erase oscillator circuit is driven by the motor power supply.

The bias current for any particular type of tape is selectable by the circuit shown below (selection of bias current is independent of tape speed).

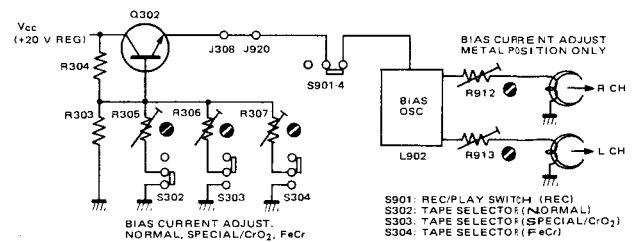

Referring to the above diagram, the bias current is adjusted by Q302 which changes the operating voltage of the BIAS OSC circuit at each tape selector switch position. In the "Metal" position, the operating voltage is set by R304 and R303, while its bias current is determined by R912 (R913).

- Erase current is increased only at the "Metal" position by shorting the series resistor (R916) of the oscillator circuit power supply with S305 (Metal).

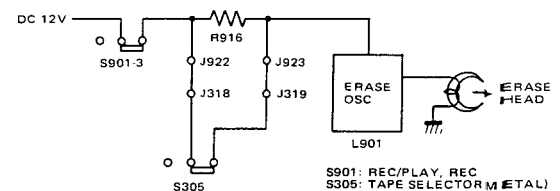

4. DISASSEMBLY

4.1 REMOVING THE CASSETTE CASE ESCUTCHEON

Remove the two screws holding the escutcheon and take this out for removal.

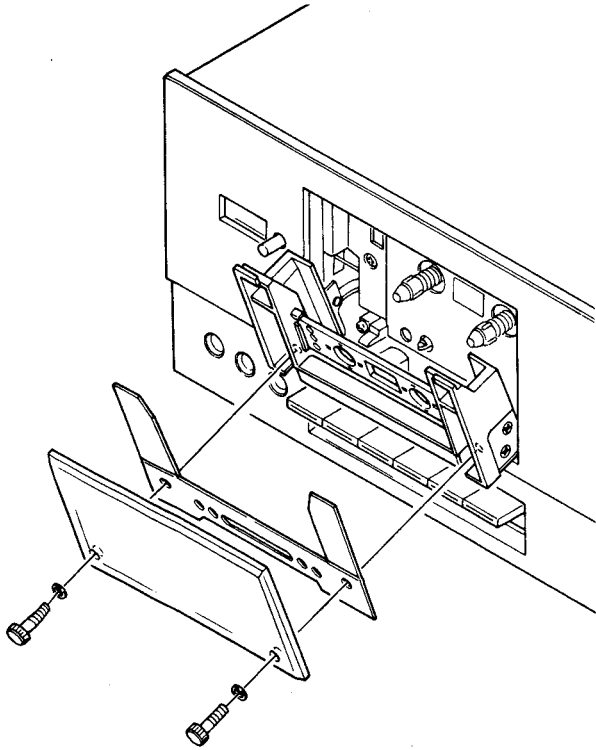

4.2 REMOVING THE FRONT PANEL

Remove the six knobs 1, 2, 3, 4, 5, and 6. Then, remove the five screws A, B, C, D, and E.

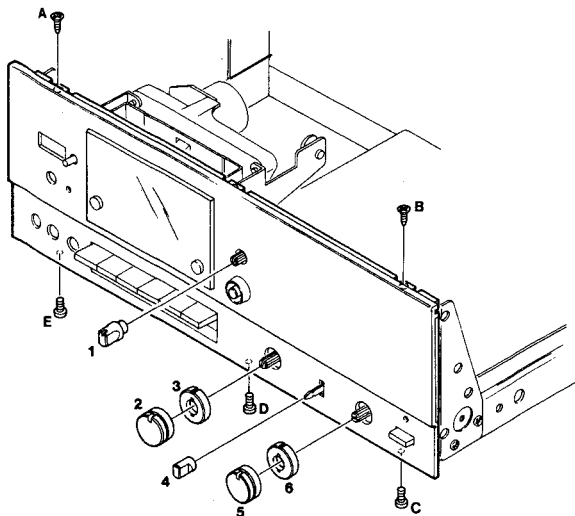

4.3 REMOVING THE MECHANICAL CHASSIS

Remove the two screws F and G holding the bracket, which installing the Skip P.W. board (P450) on the rear of the main chassis. Take the bracket out for removal.

1. Remove the front panel.
2. Remove the two screws H and I holding the push-switch on the Skip P.W. board to the front bracket.
3. Remove the five screws A, B, C, D and E holding the mechanical chassis.
4. Remove the record lever spring assembly J. Then, draw the chassis out with taking care of the tape counter and operating levers.

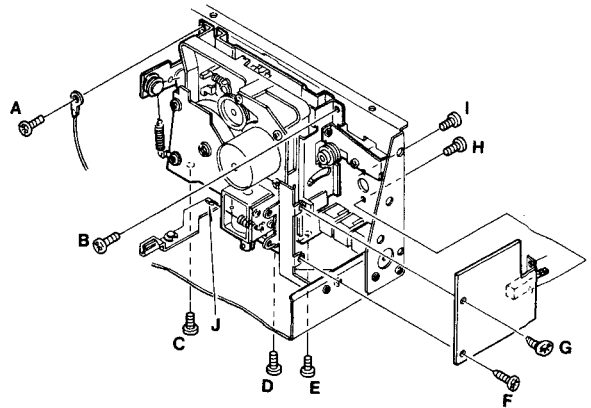

4.4 REMOVING THE PRE AMP P.W. BOARD

1. Remove the seven screws A, B, C, D, E, F, G and H holding the Pre Amp P.W. board.
2. Remove the nut I holding the speed selector switch. Then, draw it out with taking care of not applying excessive force to any lead wire.

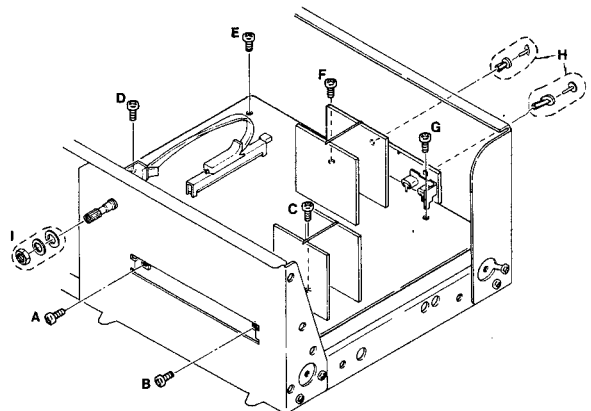

5. MECHANICAL ADJUSTMENTS

5.1 ADJUSTING THE FLYWHEEL THRUST

Adjust the thrust screw at the flywheel bracket until the clearance between the capstan tail end and thrust bearing is 0.1 to 0.3 mm as shown, using a phillips screw driver. For adjusting, feel of axial dropping of the flywheel for proper clearance as this cannot be seen through. Then paint the screw to lock.

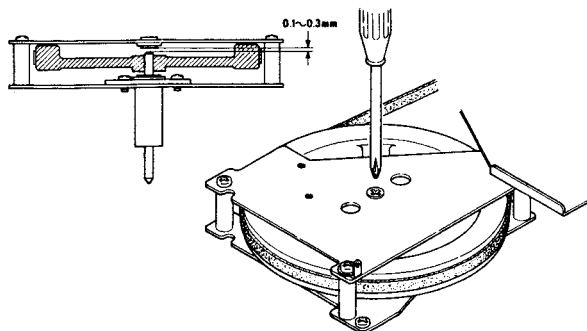

5.2 ADJUSTING THE PAUSE TIMING

Set the unit in the play mode of operation. Then, adjust the bend angle of the pinch roller bracket arm (point A in the line drawing) until the clearance between the pinch roller and capstan is 0.1 to 0.3 mm at the time when the take-up reel is stopped by slowly pressing the PAUSE pushbutton down.

NOTE: To widen the clearance, make the bend angle smaller (in the direction C). To make the clearance narrower, widen the bend angle (in the direction B).

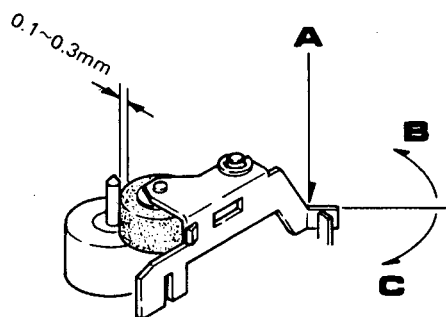

5.3 ADJUSTING THE PINCH ROLLER PRESSURE

Measure the pressure of the pinch roller using a gauge as shown. For measurement, draw the pinch roller in the arrow direction in which it is detached from the capstan shaft and gradually return it toward the capstan. Read the gauge at the time when the pinch roller starts turning. The standard pressure is 300 ± 50 g. If the pressure is out of the range, bend the pinch roller spring around the point A in the direction B or C.

NOTE: To make the pressure strong, bend in the direction B. To make the pressure weak, bend in the direction C.

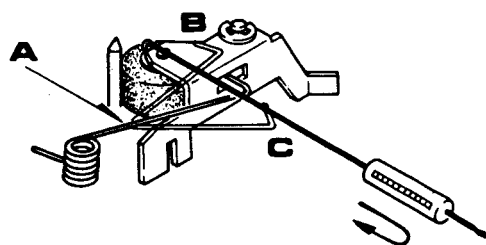

5.4 ADJUSTING THE PLAY TIMING

It is normal that when the PLAY pushbutton is depressed, the take-up reel table turns first, then the pinch roller is rotated. The reel table and pinch roller must not start turning at the same time.

NOTE: Make certain that such a subsequent operation is made irrespective of locking state is depressed slowly without loading the tape.

1. Checking for Adjustment

Check whether or not the clearance between the pinch roller and capstan is 0.2 to 0.5 mm when the take-up reel table starts turning with the PLAY pushbutton depressed slowly.

2. Adjustment

Bend the pinch roller bracket at the point that touches the head chassis stopper. In the line drawing, bending left reduces the clearance between the capstan and pinch roller.

NOTE: Make certain that the pinch roller bracket does not leave touching the head chassis stopper in the play mode of operation as a result of excessive bending.

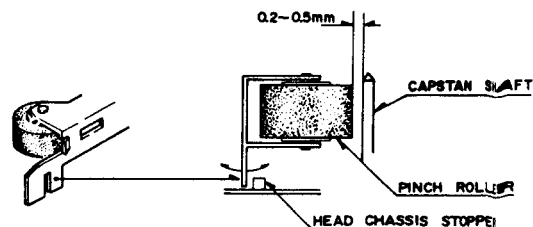

5.5 ADJUSTING THE PLAY TORQUE

Put the two pawls of the circular plate spring on proper stepped position of the reel rest. The adjustable torque range is 40 to 70 g-cm.

To make the torque high, put the pawls on a shallow step. For lower torque, put them on a deeper step.

- **Checking the take-up clutch for sliding**

Make certain that the flywheel rotates freely when the reel table is locked. The flywheel that revolves irregularly or stops is not acceptable.

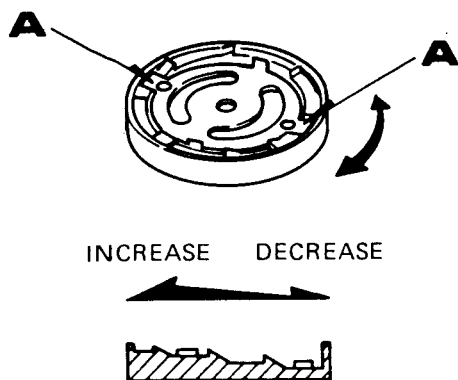

5.6 ADJUSTING THE FAST FORWARD AND REWIND TORQUE

The fast forward and rewind idler has a torque adjust plate spring (part A in the line drawing), which has two pawls (part B) at its ends. Set the pawls in proper one of the three steps. To make the torque high, set the pawls in the shallowest step. For lower torque, set in the deepest step.

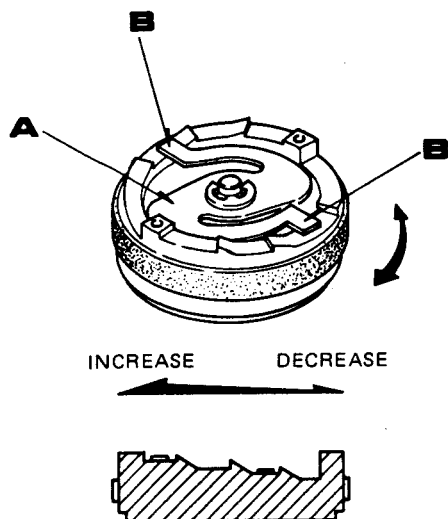

5.7 POSITIONING THE MOTOR PULLEY

Loosen the set screw and adjust the motor pulley position until the clearance between the pulley and motor is 4 mm as shown. Tighten the set screw.

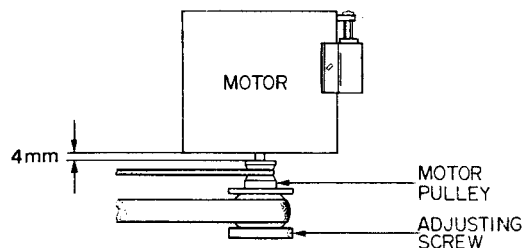

5.8 ADJUSTING THE REWIND IDLER SIDE PRESSURE

Make certain that in the rewind mode of operation, the rewind idler does not slip on the supply reel table when this is held by hand. If it slips, change the hanging position of the rewind idler arm return spring on the chassis in the arrow direction step by step until it does not slip.

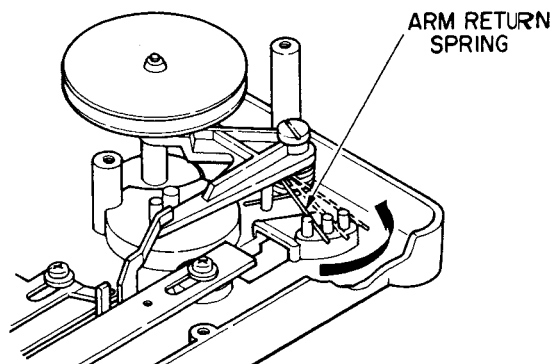

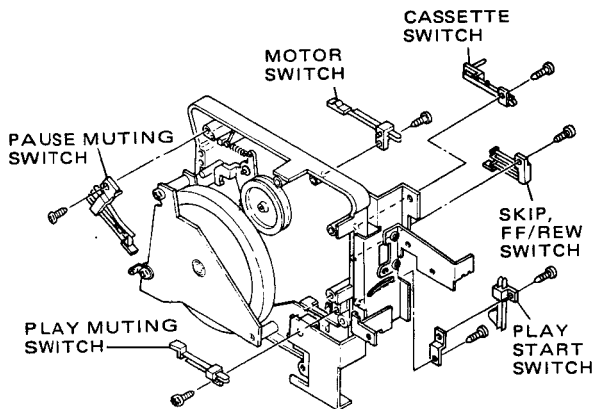

5.9 POSITIONING THE SWITCHES

5.9.1 Normal Motor Speed Switch

This switch turns OFF in PLAY, FF or REW mode. The functions of the switch are as follows:

- 1) The tape speed select switch (manual type switch on front panel) circuit will not function when the switch is ON.
- 2) The tape speed select switch circuit is activated when the switch is OFF.

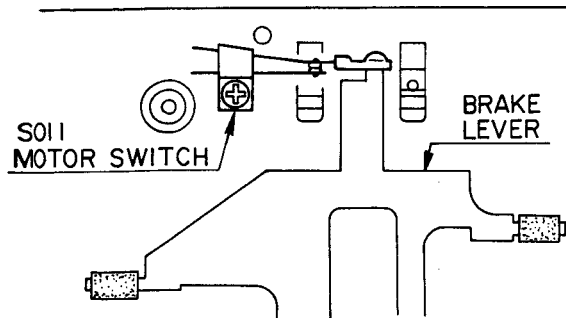

5.9.2 Pause Muting Switch (S003)

In the stop state, loosen the screw holding the pause muting switch and position this so that the clearance between its end tip and pause arm may be 1 to 1.5 mm.

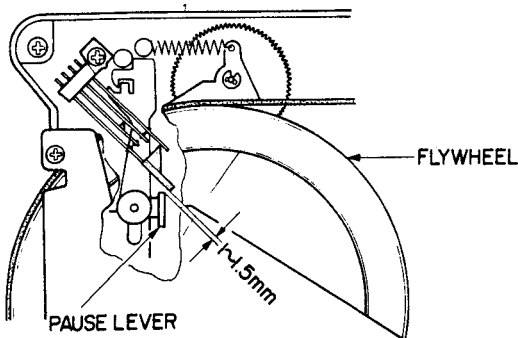

5.9.3 SKIP, FF/REW and Cassette Switches

a) SKIP and FF/REW Switches

- When installing, observe the following points:
 - 1) This switch is activated by the lever (1).
 - 2) This switch should be installed so that it is quickly depressed by the lever (1).
- The functions of the switch are as follows:
 - 1) Turns ON and OFF the SKIP circuit.
 - 2) Sets the motor speed to 1000 rpm in FF/REW (CUE/REV) mode.

b) Cassette Switch

- When installing, observe the following points:
 - 1) Make sure that the switch does not contact other parts of the mechanism.
 - 2) Check that the switch turns ON when cassette tape is loaded. (Motor starts running.)
- Function of switch:
 - 1) Improves the motor speed rising characteristic.

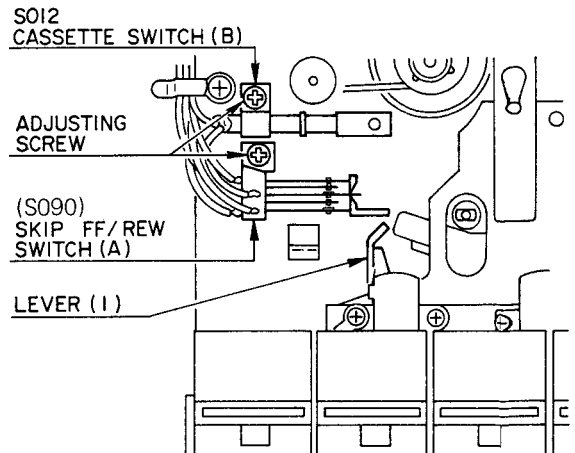

5.9.4 Play Muting Switch

In the stop state, loosen the screw holding the play muting switch and position this so that the clearance between its end tip and play lever may be 4 mm.

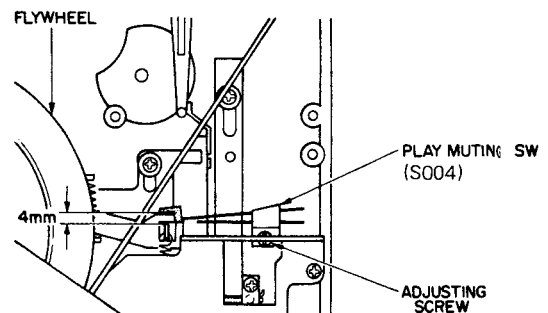

5.9.5 Play Start Muting Switch

When installing, observe the following points:

- 1) Press the PLAY button and check that this switch is set to OFF → ON → OFF until locked.
- 2) Check that this switch remains OFF in CUE/REV mode.

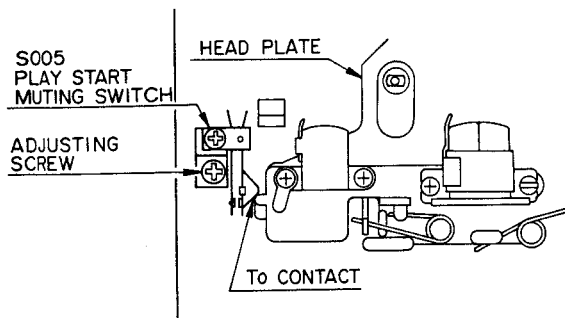

Caution for Installing the Solenoid L010

For skipping tape, either REW or FF button together with the PLAY button should be depressed to lock. When skipping ends, the skip circuit energizes the solenoid to release the REW or FF button only. If the solenoid is not positioned well, however, this would result in releasing the PLAY button too. In such an event, correct the solenoid position so that the PLAY button cannot be released.

6. ELECTRICAL ADJUSTMENTS

Precautions before Adjustment

1. Before playing the test tape back, thoroughly demagnetize the heads, capstan and similar metal parts using an eraser as the test tape-recorded tone is easily erased.
2. Do not place the test tape on any measuring instrument.
3. Do not put the test tape near a place where the eraser is used.
4. Method of Demagnetization: — Turn the eraser power switch on at a remote position far away from the heads. Bring the eraser close to the heads, capstan and other parts to be demagnetized, and move it up and down four or five times to demagnetize. Slowly separate the eraser far away from the parts, and turn the power switch off.
5. Do not use any magnetized adjusting tool. When using it, demagnetize it from time to time in the course of each adjustment.
6. Do not turn semi-fixed resistor more than needed.
7. Do not apply locking bond excessively.

Definitions

1. The "normal playback state" is an operating state of the tape deck which plays back the MTT-150 test tape and is adjusted so as to produce a 580mV output at the LINE OUTPUT terminal with the load assuming the measuring instrument input impedance of greater than 100 k Ω and with the TAPE SELECTOR switch set at the NORMAL position.
2. The "normal recording state" is an operating state of the tape deck which records a 1 kHz signal to a specified recording level for which the recording level control is adjusted with the 1 kHz signal applied at a specified input level to the MIC terminal.
In the normal recording state, therefore, this tape deck is set up with the level control to the state that the Peak Level Displays may illuminate to the 0 VU with a 1 kHz, 1 mV input signal applied.

6.1 HEAD AZIMUTH ADJUSTMENT

SET UP

1. Power voltage:- 50 or 60 Hz AC voltage rated for the unit to be used in a market country.
2. TAPE SELECTOR switch position:- NORMAL.
3. Load:- Measuring instrument input impedance.
4. Output terminal used:- LINE OUTPUT.
5. Test tape used:- MTT-115C (31.5 Hz to 14 kHz).
6. Tape Speed:- 1-7/8 IPS (4.75 cm/sec).

PROCEDURES

1. Play the 315 Hz and 10 kHz portions of the test tape MTT-115C back. Adjust the head azimuth adjusting screw for maximum VTVM read.
2. If the peak output reads of the right and left channels are different, set the screws to obtain the mechanical center between the peaks.
3. After adjustment, lock the screw with bond.

Mode: Playback

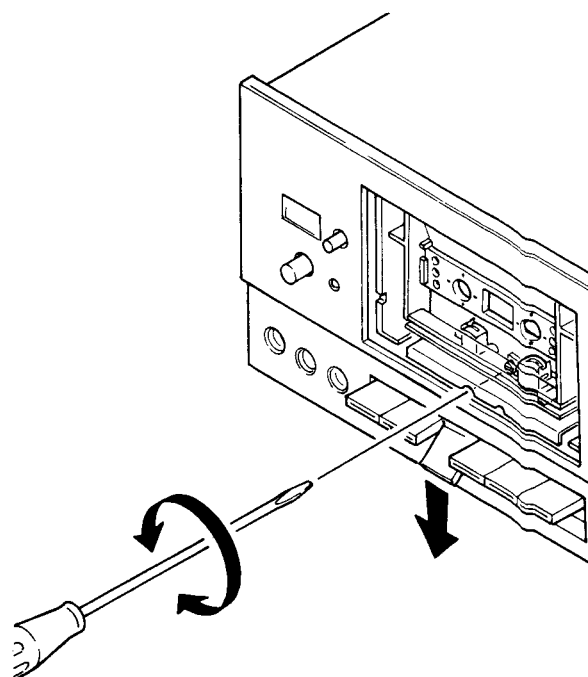
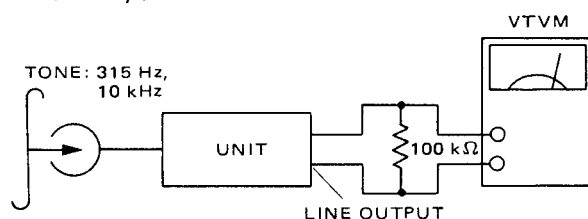

CAUTION

After adjustment, repeat the playback and stop setting a few times to make certain of no head azimuth deviation.



6.2 TAPE SPEED ADJUSTMENT

SET UP

1. Power voltage:- 50 or 60 Hz AC voltage rated for the unit to be used in a market country.
2. Output terminal:- LINE OUTPUT (or DIN).
3. Test tape used:- MTT-111 (3 kHz Tone) at 1-7/8 IPS (4.75 cm/sec).
MTT-111SP at 3-3/4 IPS (9.5 cm/sec).
4. Unit position:- Vertical.

PROCEDURES

1. For 1-7/8 ips (4.75 cm/sec), play the mid portion of the test tape MTT-111 back. Adjust the tape speed adjusting variable resistor inside the motor for 2990 to 3010 Hz counter indication.
2. For 3-3/4 ips (9.5 cm/sec), play the mid portion of the test tape MTT-111SP back. Adjust R310 for 2990 to 3010 Hz counter indication.

CAUTIONS

1. For adjustment, the tape deck should be set up in the normal operating condition.
2. Do not adjust the variable resistor more turns than needed.
3. Do not proceed with adjustment after the tape deck temperature has changed.
4. If a strong shock or similar vibration is applied to the tape deck after adjustment, make certain that the measured tape speed had not changed.
5. If the tape speed deviation occurs, perform the adjustment again.
6. Be careful that the counter may indicate a wrong value because of too low counter input level.
7. Before adjustment, allow for 30 seconds or more after depressing of the PLAY pushbutton.

NOTE: Be sure to carry out the 1-7/8 ips (4.75 cm/sec) tape speed adjustment for first.

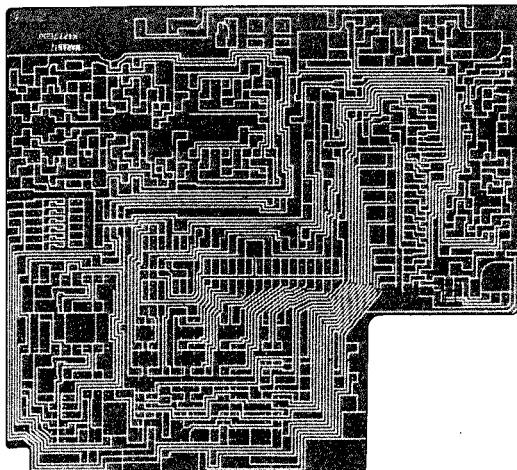
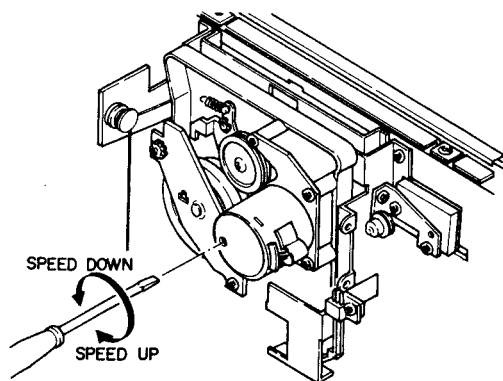
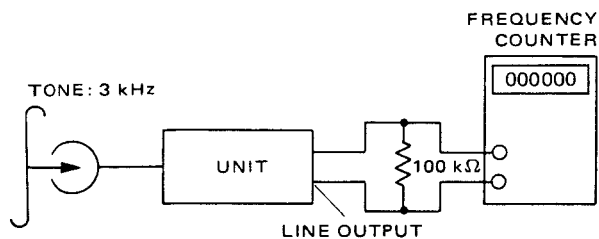

6.3 PLAYBACK EQUALIZER ADJUSTMENT

SET UP

1. Power voltage:- 50 or 60 Hz AC voltage rated for the unit to be used in a market country.
2. TAPE SELECTOR switch position:- NORMAL.
3. Load:- Measuring instrument input impedance.
4. Output terminal:- LINE OUTPUT.
5. Test tape used:- MTT-115C.
6. Tape Speed:- 1-7/8 IPS (4.75 cm/sec).

PROCEDURES

1. Play the test tape MTT-115C. Let the 315 Hz signal level be reference as 0 dB.
2. Adjust R160 and R260 (5 k Ω each) for 10 kHz frequency response of 0 to ± 1 dB in reference to the 315 Hz signal level.

- NOTES:**
1. Proceed both for the right and left channels in the same manner.
 2. Note that clockwise turning of R160 and R260 will increase the 10 kHz signal output level.

Mode: Playback

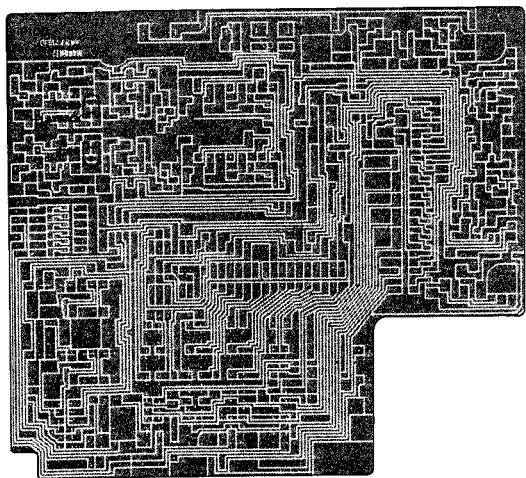
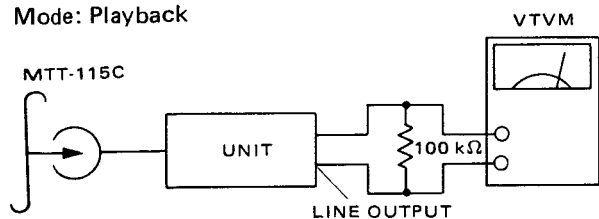

6.4 PLAYBACK OUTPUT ADJUSTMENT

SET UP

1. Power voltage:- 50 or 60 Hz AC voltage rated for the unit to be used in a market country.
2. TAPE SELECTOR switch position:- NORMAL.
3. Load:- Measuring instrument input impedance.
4. Output terminal:- LINE OUTPUT.
5. Test tape used:- MTT-150.
6. Tape Speed: 1-7/8 IPS (4.75 cm/sec).

PROCEDURES

Play the test tape MTT-150 back. Adjust R166 and R266 (50 k Ω each) for 580 mV playback output level.

NOTE: Proceed both for the right and left channels in the same manner.

Mode: Playback

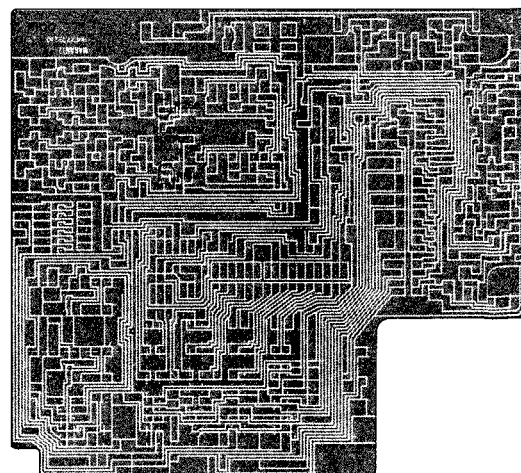
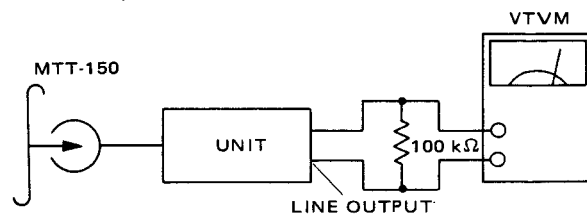

CAUTION

This adjustment should be performed after the one for the playback equalizer. If the playback equalizer is adjusted after the playback output adjustment, the playback output should be readjusted.

6.5 LED PEAK LEVEL METER ADJUSTMENT

SET UP

1. Power voltage:- 50 or 60 Hz AC voltage rated for the unit to be used in a market country.
2. TAPE SELECTOR switch position:- NORMAL.
3. Input terminal:- J601, J621.
4. Test tape used:- MTT-150
5. Tape Speed:- 1-7/8 ips (4.75 cm/sec).

PROCEDURES

1. Supply DC 3 V between J601 and J621.
2. Depress the PLAY button.
3. Adjust R602 and R622 for 0VU LED meter reading.
4. Remove DC 3 V from J601 and J621.
5. Play the test tape MTT-150 back.
6. Adjust R610 and R630 for +2 dB LED meter reading.

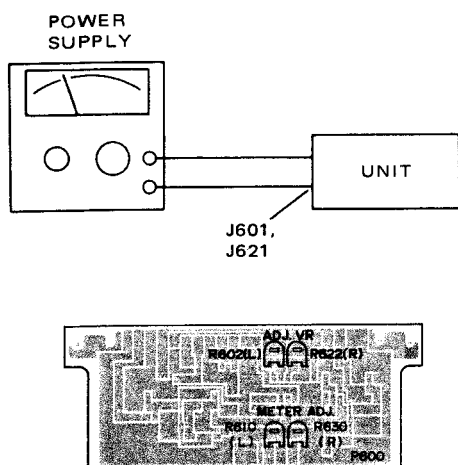

6.6 RECORDING BIAS CURRENT ADJUSTMENT

SET UP

1. Power voltage:- 50 or 60 Hz AC voltage rated for the unit to be used in a market country.
2. TAPE SELECTOR switch:- METAL.
3. Load:- Measuring instrument input impedance.

PROCEDURES

Set up the tape deck in the recording mode of operation. Connect the VTVM to R906 (Lch) and R907 (Rch). Adjust the variable resistor R912 and R913 for 2 mV VTVM read.

NOTE: Proceed both for the right and left channels in the same manner.

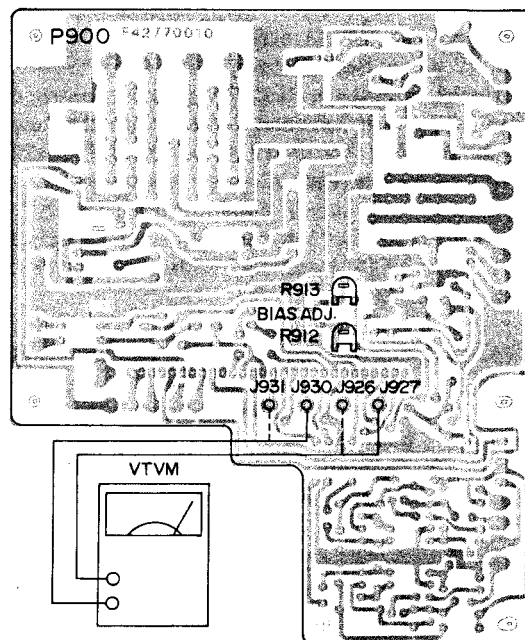

6.7 RECORDING CURRENT ADJUSTMENT

SET UP

1. Power voltage:- 50 or 60 Hz AC voltage rated for the unit to be used in a market country.
2. Input signal:- 1 kHz, 1 mV.
3. TAPE SELECTOR switch position:- NORMAL.
4. Load:- Measuring instrument input impedance.
5. Tape Speed:- 1-7/8 IPS (4.75 cm/sec) or 3-3/4 IPS (9.5 cm/sec).

PROCEDURES

1. Stop the recording bias current oscillation by disconnecting the bias circuit. For example, connect the base and emitter of Q910 the base and emitter of Q911. (Complete adjustment as quickly as possible.)
2. Set up the tape deck to the normal recording state. Connect the VTVM across the $10\ \Omega$ resistor connected to the head. Supply 1 kHz, 1 mV to the MIC terminal. Adjust the RECORD LEVEL control until the LED meter indicates 0VU. Adjust the variable resistors R111 (or R112*) and R211 (or R212*) until the VTVM reads 0.5 mV, respectively.
3. Operate the oscillation circuit. Record 1 kHz, 1 mV signal. Play back the recorded signal and adjust R111 (or R112*) and R211 (or R212*) for 0VU LED meter reading.

- NOTES:**
1. Proceed both for the right and left channels in the same manner.
 2. After adjustment, release the recording bias current.
 3. Resistors marked * are to be adjusted for 3-3/4 ips (9.5 cm/sec).

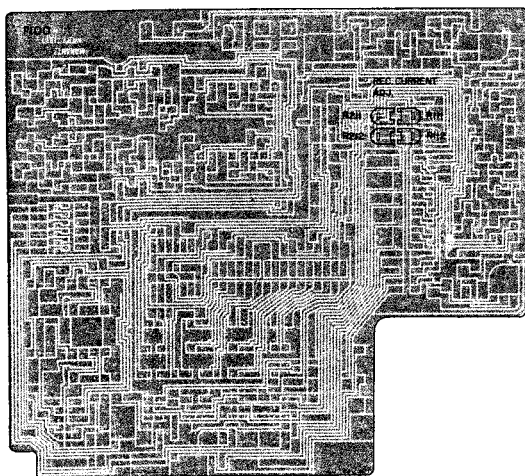

6.8 MPX FILTER ADJUSTMENT

SET UP

1. Power voltage:- 50 or 60 Hz AC-voltage rated for the unit to be used in a market country.
2. Input terminal:- MIC.
3. TAPE SELECTOR switch:- NORMAL.
4. Output terminal:- LINE OUTPUT.
5. Load: Measuring instrument input impedance.

PROCEDURES

1. Connect the 19 kHz, -60 dB input signal to the MIC terminal. Adjust the LINE LEVEL control for 0 VU.
2. Turn the MPX FILTER pushswitch to the ON position. Adjust the L101 and L201 for minimum output level at the LINE OUTPUT terminal.

NOTE: Proceed both for the right and left channels in the same manner.

Mode: Record

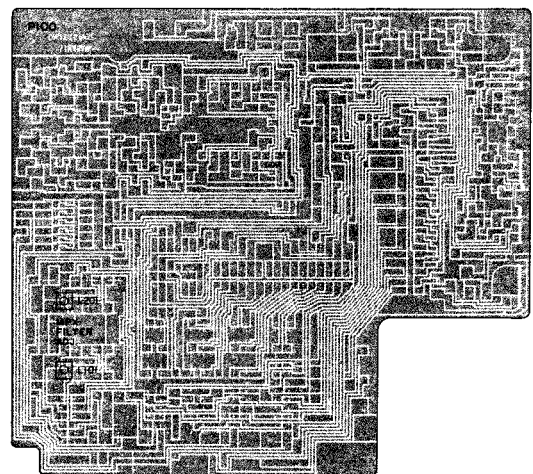
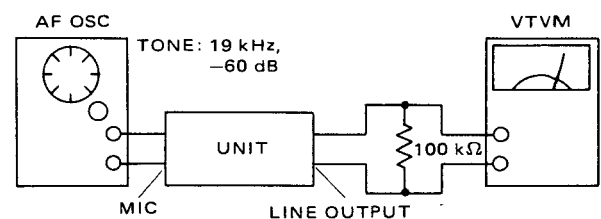

CAUTIONS

1. The 19 kHz input signal should be as precise as 19 ± 0.01 kHz.
2. If the filter characteristic is better than 30 dB, the adjusting coil needs not to be adjusted since it is factory set.

6.9 RECORD-PLAYBACK FREQUENCY RESPONSE ADJUSTMENT

SET UP

1. Power voltage:- 50 or 60 Hz AC voltage rated for the unit to be used in a market country.
2. Input signal:- 1 kHz, -60 dB with -20 dB referenced as 0 dB.
3. TAPE SELECTOR switch:-METAL.
4. Output terminal:- LINE OUTPUT.
5. Load:- Measuring instrument input impedance.
6. Playback output level:- 43 mV (same as recorded signal level).
7. Test tape used:-METAL C-46.
8. Tape Speed:- 1-7/8 IPS (4.75 cm/sec).

PROCEDURES

1. Connect the input signal to the MIC terminal. Set up the tape deck to the normal recording state.
2. In turn, reduce the input level by 20 dB with the use of the attenuator. Record the 1 kHz and 12.5 kHz tones.
3. Play the 1 kHz, 20 dB-down recorded tone back as 0 dB. Adjust the recording bias current until the 12.5 kHz response is within ± 1 dB as referenced to the 1 kHz, 0 dB response by adjusting R912 and R913.
4. Adjust the recording bias current by using test tapes AC701, AC-511 and CS-30 in the same manner.
 - AC701 : R305 (Metal)
 - AC-511 : R306 (CrO₂/Special)
 - CS-30 : R307 (FeCr)

- NOTES:**
1. Proceed both for the right and left channels in the same manner.
 2. If the recording bias current is reduced in the above adjustment, be sure to measure the distortion.

Mode: Record

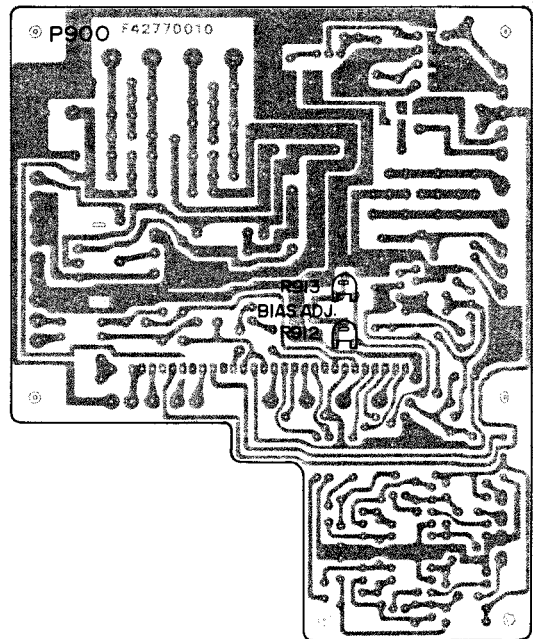
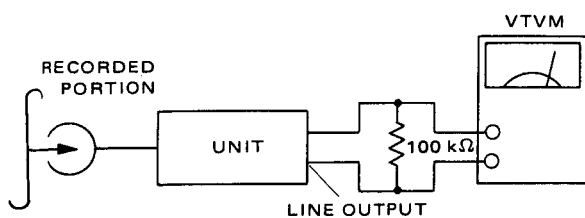
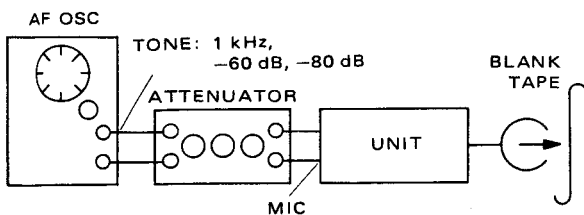

7. VOLTAGE CONVERSION

To convert the unit to a different power source voltage, change the position as illustrated in the drawing below.

CAUTION: DISCONNECT POWER SUPPLY CORD FROM AC OUTLET BEFORE CONVERTING VOLTAGE. DO NOT DISASSEMBLE THE VOLTAGE SELECTOR ABSOLUTELY.

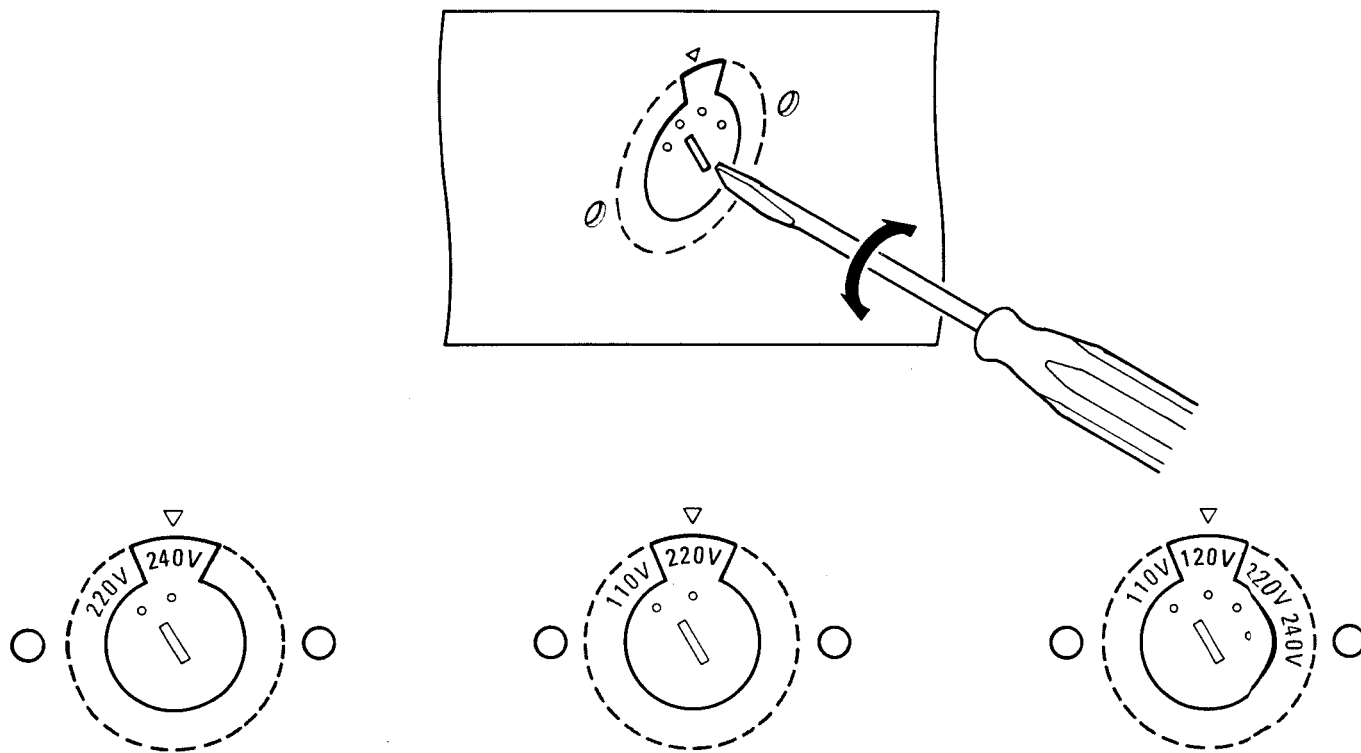

NOTE ON SAFETY: THE PARTS MARKED WITH  ARE IMPORTANT PARTS ON THE SAFETY. PLEASE USE THE PARTS HAVING THE DESIGNATED PARTS NUMBERS WITHOUT FAIL.

8. DIAGRAMS

8.1 BLOCK & LEVEL DIAGRAM

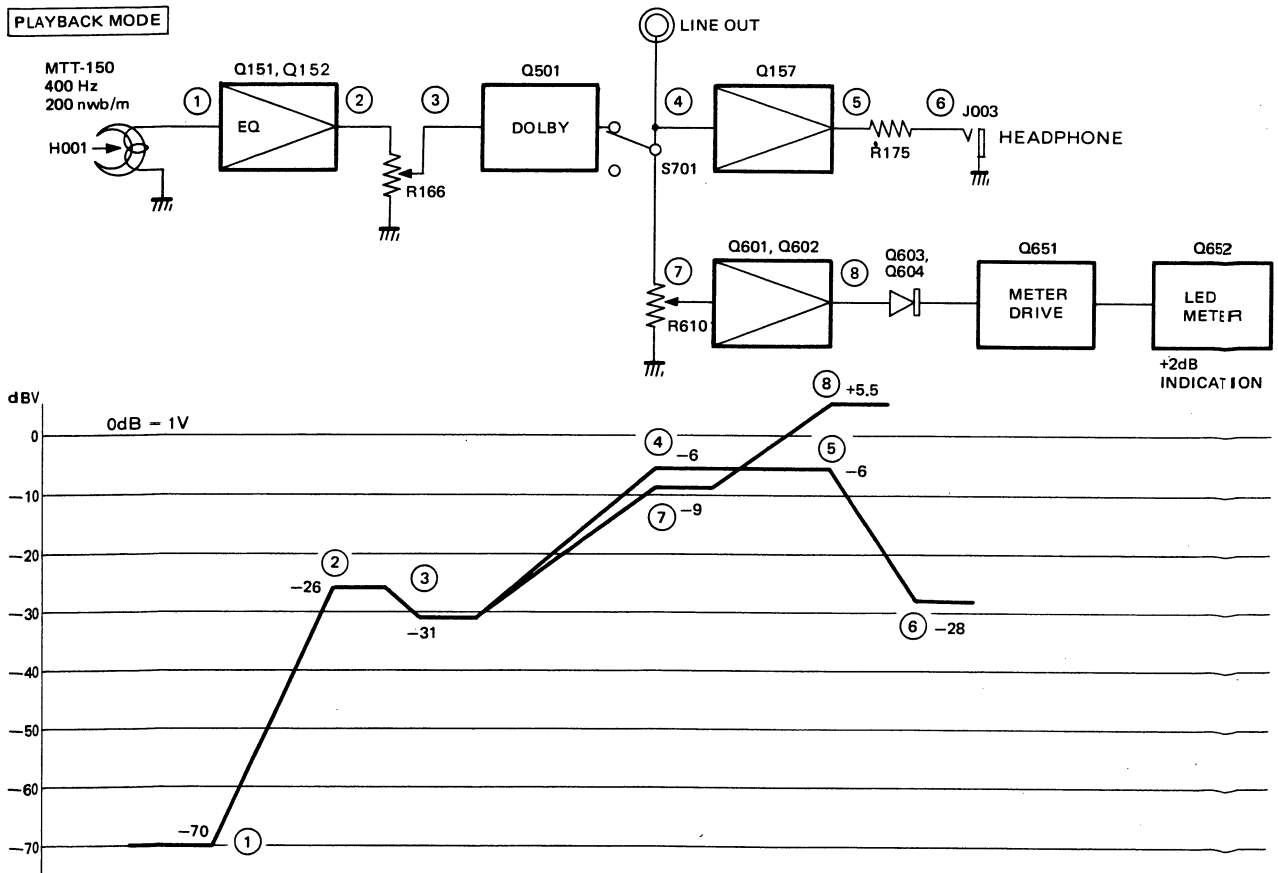
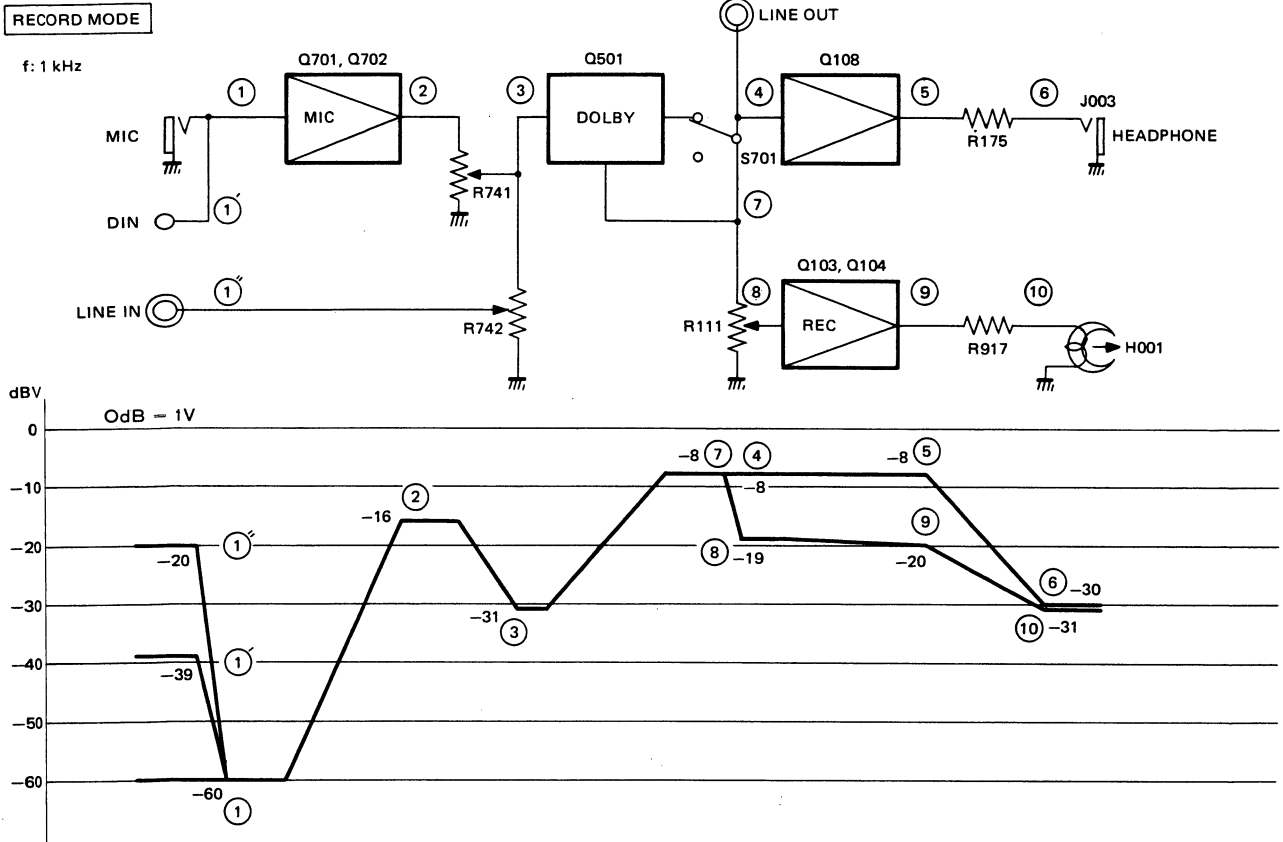

8.2 PRE AMP SCHEMATIC DIAGRAM AND COMPONENT LOCATIONS-P100

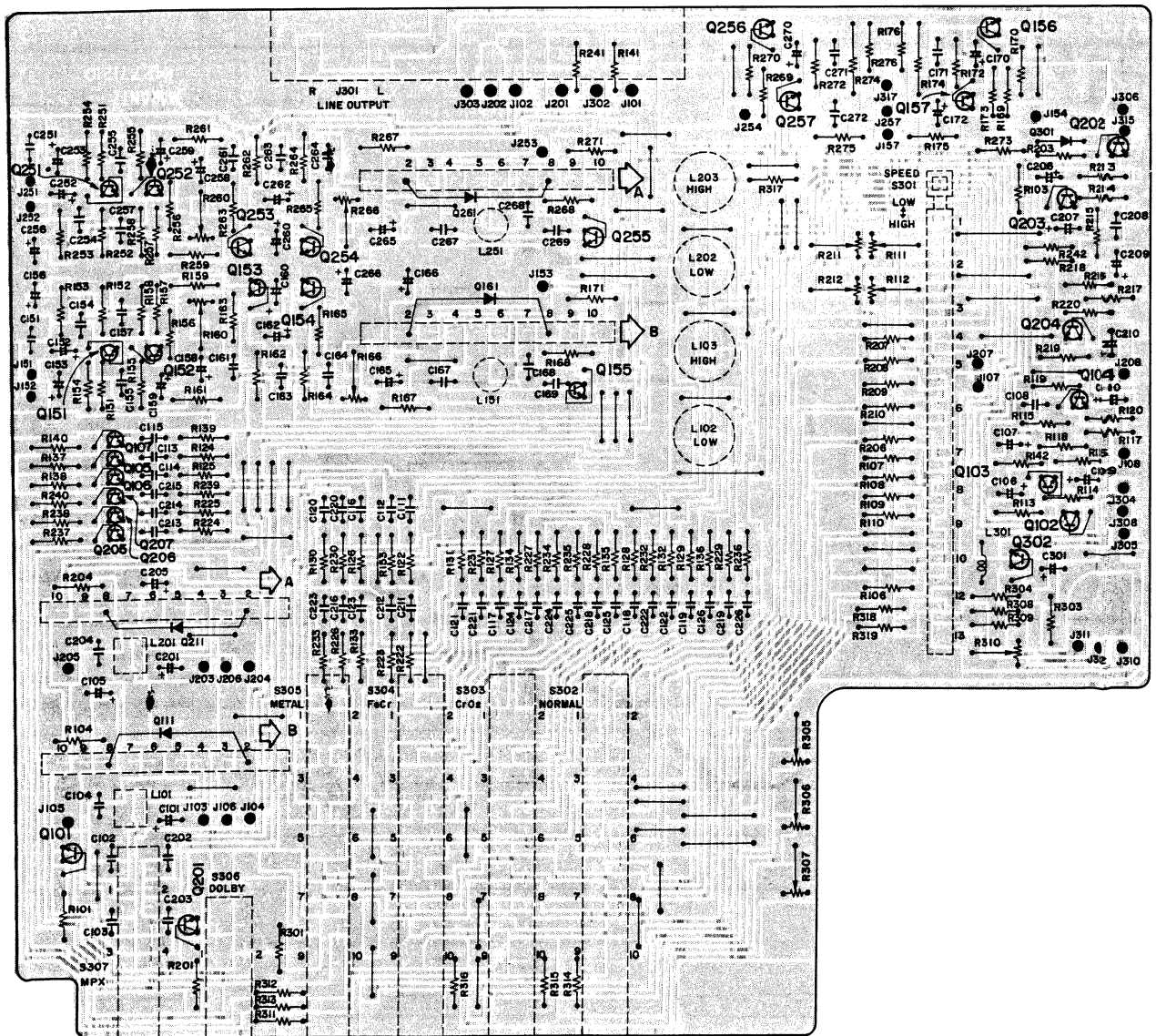
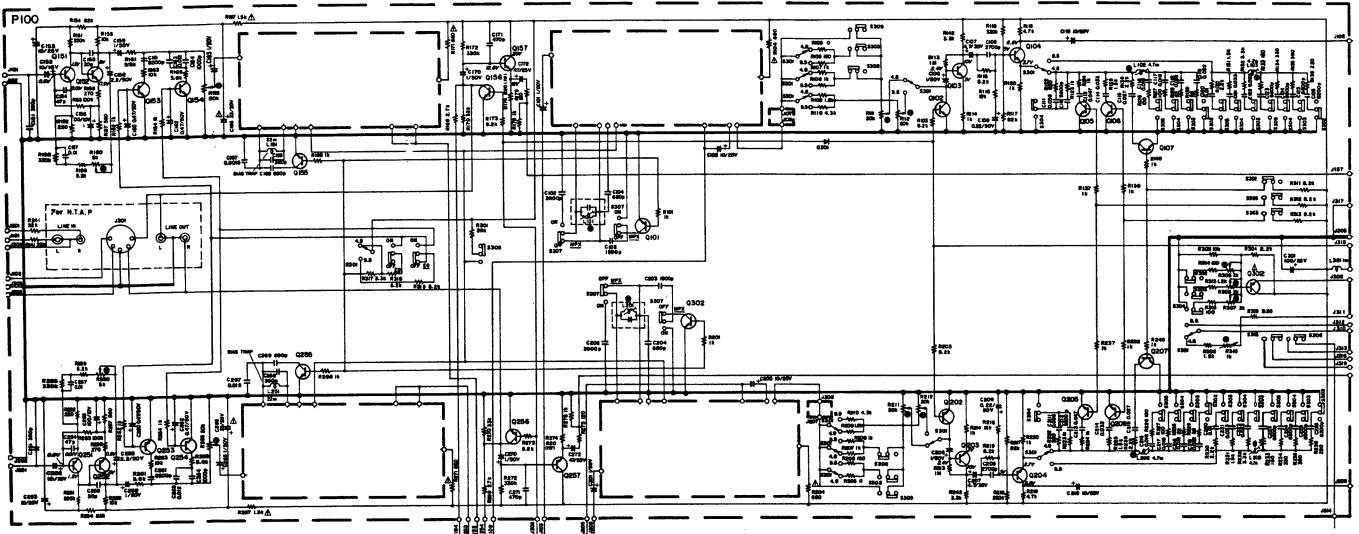



8.3 FUSE SCHEMATIC DIAGRAM AND COMPONENT LOCATIONS-P400-FOR N VERSION

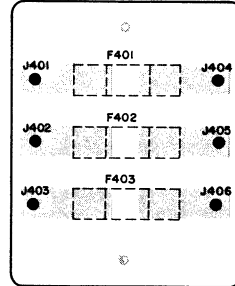

8.4 COMPUSKIP SCHEMATIC DIAGRAM AND COMPONENT LOCATIONS-P450

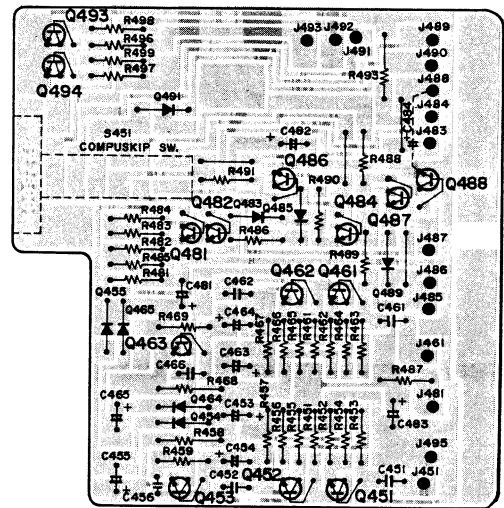
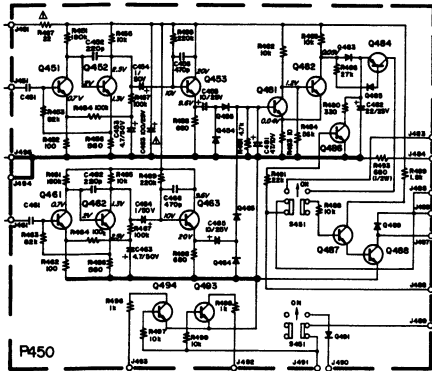

8.5 DOLBY SCHEMATIC DIAGRAM AND COMPONENT LOCATIONS-P500

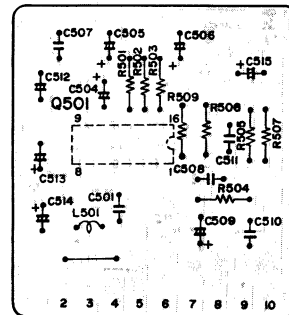
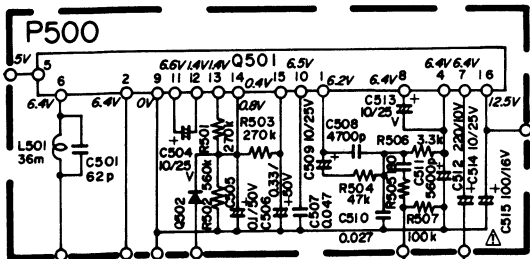

X

8.6 LED METER AMP SCHEMATIC DIAGRAM AND COMPONENT LOCATIONS-P600

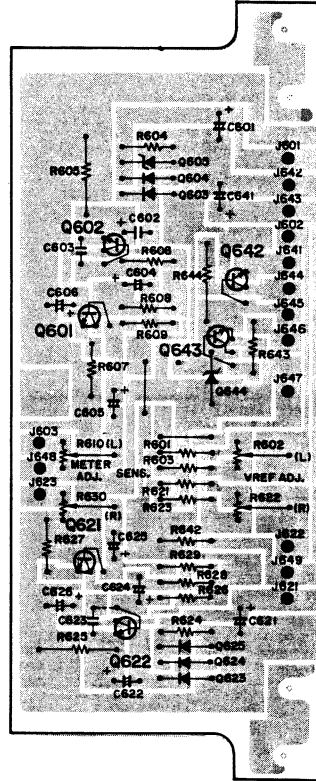
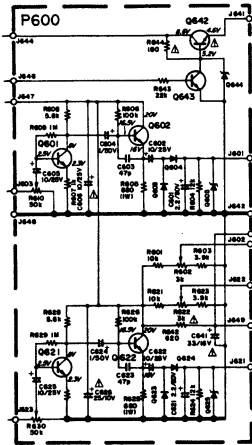

8.7 LED METER SCHEMATIC DIAGRAM AND COMPONENT LOCATIONS-P650

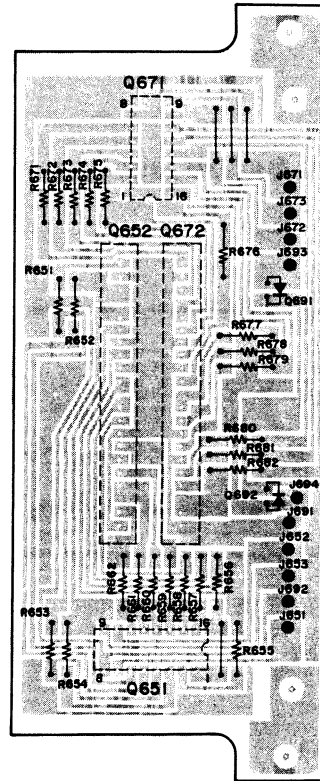
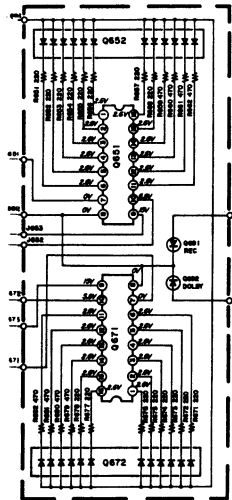

9. EXPLODED VIEWS AND PARTS LIST

9.1 [P01-99] FRONT PANEL

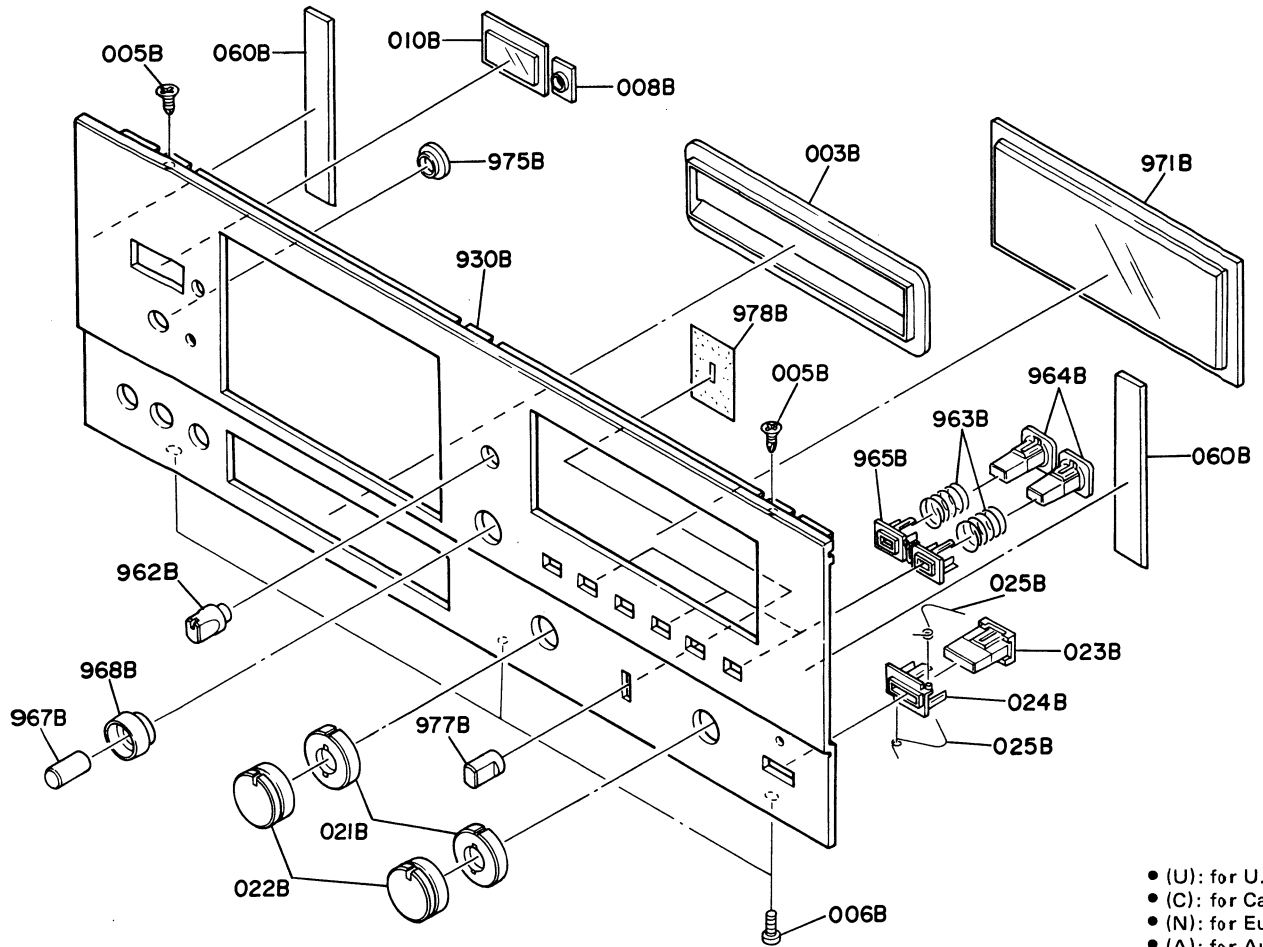

- (U): for U.S.A.
- (C): for Canada
- (N): for Europe
- (A): for Australia

REF. DESIG.	Q'TY				PART NO.	DESCRIPTION
	U	C	N	A		
A	1	1	1		4277063400	Front Panel Assembly
A1			1		4277063410	Front Panel Assembly
003B	1	1	1	1	4276259020	Bushing, Button
008B	1	1	1	1	3448259100	Bushing, Reset Knob
010B	1	1	1	1	4276158040	Window, Counter
024B	1	1	1	1	2127259010	Bushing, Power
060B	2	2	2	2	2128118010	Spacer
930B	1	1			4277063010	Escutcheon
930B			1	1	4277063020	Escutcheon
965B	3	3	3	3	2112259020	Bushing, Selector
968B	1	1	1	1	4276259010	Bushing, Rec Mut
971B	1	1	1	1	4276158030	Window, Led Meter
975B	1	1	1	1	3448259010	Bushing, Skip
978B	1	1	1	1	4277107010	Sheet, Monitor Switch

REF. DESIG.	Q'TY				PART NO.	DESCRIPTION
	U	C	N	A		
005B	2	2	2	2	51500306B0	F.H. Taptite Screw F3 x 6
006B	3	3	3	3	51100306A9	B.H.M. Screw B3 x 6
021B	2	2	2	2	4277154010	Knob, Rec Level
022B	2	2	2	2	4277154020	Knob, Rec Level
023B	1	1	1	1	2127154010	Knob, Power
025B	2	2	2	2	2127115010	Spring
962B	1	1	1	1	4276154010	Knob, Speed
963B	6	6	6	6	2112115010	Spring
964B	6	6	6	6	2112154010	Knob, Selector
967B	1	1	1	1	3448154060	Knob, Rec Mute
977B	1	1	1	1	2970154020	Knob, Monitor Switch

9.2 [P02-99] FRONT BRACKET

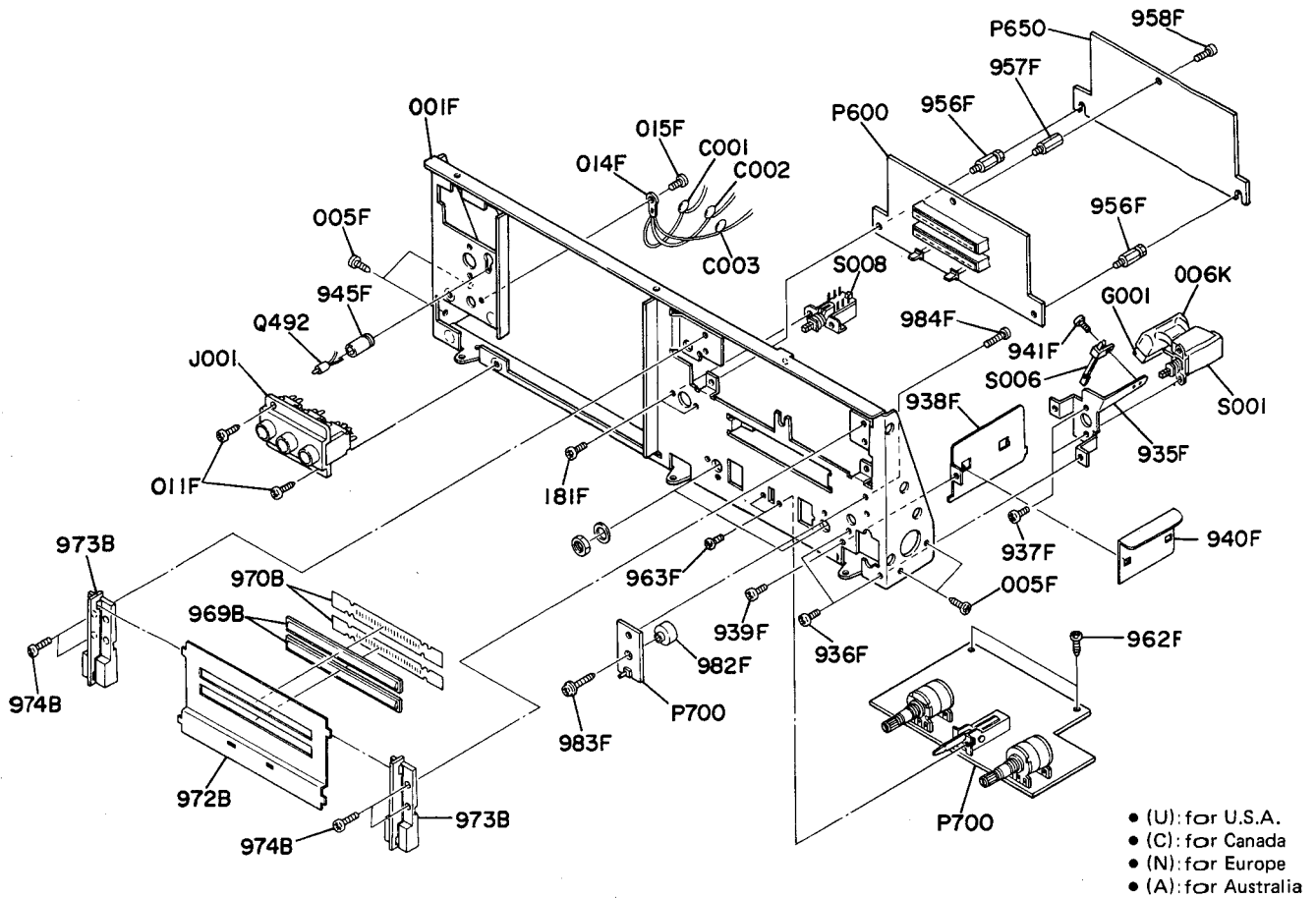

REF. DESIG.	Q'TY				PART NO.	DESCRIPTION
	U	C	N	A		
B	1	1	1	1	4276302410	Dial Assembly, LED Meter
969B	2	2	2	2	2127355010	Lens
970B	2	2	2	2	2129303040	Mask
972B	1	1	1	1	4276302020	Dial
973B	2	2	2	2	4276104010	Retainer
974B	4	4	4	4	51100308A9	B.H.M. Screw B3 x 8
001 F	1	1	1	1	4276160050	Bracket
005 F	4	4	4	4	51280306B0	B.H. Tapped Screw B3 x 6
011 F	2	2	2	2	51280308B0	B.H. Tapped Screw B3 x 8
014 F	1	1	1	1	62031650W0	Lug
015 F	1	1	1	1	51100306A9	B.H.M. Screw B3 x 6
181 F	2	2	2	2	51100306A9	B.H.M. Screw B3 x 6
935 F	1	1	1	1	4276160020	Bracket
936 F	2	2	2	2	51100306A9	B.H.M. Screw B3 x 6
937 F	2	2	2	2	51100306A9	B.H.M. Screw B3 x 6
938 F	1	1	1	1	4276109010	Shield
939 F	1	1	1	1	51100306A9	B.H.M. Screw B3 x 6
940 F	1	1	1	1	4276120010	Insulator
945 F	1	1	1	1	4214271020	Holder
956 F	2	2	2	2	4276101010	Support
957 F	1	1	1	1	2887101030	Support
958 F	1	1	1	1	51100306A9	B.H.M. Screw B3 x 6
941 F	1	1	1	1	51100206A0	B.H.M. Screw B2 x 6

REF. DESIG.	Q'TY				PART NO.	DESCRIPTION
	U	C	N	A		
962 F	2	2	2	2	51100306A9	B.H.M. Screw B3 x 6
963 F	2	2	2	2	51100306A9	B.H.M. Screw B3 x 6
982 F	1	1	1	1	4276055010	Collar
983 F	1	1	1	1	51740312B0	Screw 3 x 12
984 F	1	1	1	1	51570310B0	P. Taptite Screw P3 x 10
006 K	1	1			4276120020	Insulator
006 K			1	1	2219120010	Insulator
C001	1	1	1	1	DK18102300	Ceramic Cap. 1000pF
C002	1	1	1	1	DK18102300	Ceramic Cap. 1000pF
C003	1	1	1	1	DK18102300	Ceramic Cap. 1000pF
Q492	1	1	1	1	H110007030	L.E.D. SLP-232B
J001	1	1			YJ01001350	Jack, Mic/Headphone
J001			1	1	YJ01001310	Jack, Mic/Headphone
Δ S001	1	1			SP01010280	Push Switch, Power
Δ S001			1	1	SP02010440	Push Switch, Power
S006	1	1	1	1	SM01010500	Mini Switch, Power Muting
S008	1	1	1	1	SP02010430	Push Switch, Rec Mute
Δ G001	1				BF10400030	Spark Killer
Δ G001		1			BF33300020	Spark Killer
Δ G001			1	1	DF17223800	Film Cap. 0.02μF ±20%

9.3 [P03-99] TOP COVER & MAIN CHASSIS

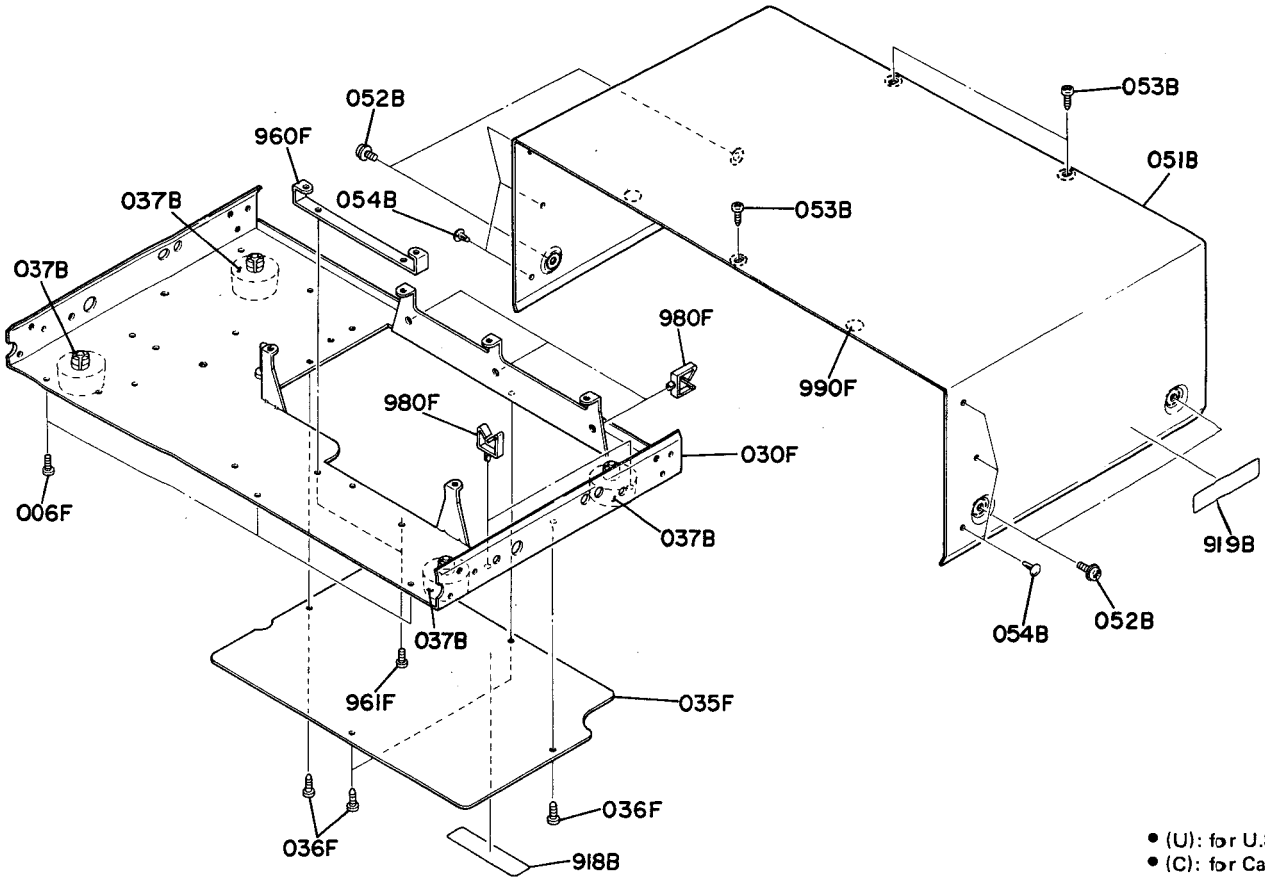

- (U): for U.S.A.
- (C): for Canada
- (N): for Europe
- (A): for Australia

REF. DESIG.	Q'TY				PARTS NO.	DESCRIPTION
	U	C	N	A		
037B	4	4	4	4	2259057010	Leg
051B	1	1	1	1	4214257010	Lid, Top Cover
052B	4	4	4	4	51480406S9	F. Washer Screw F4 x 6
053B	3	3	3	3	51280308U0	B.H. Tapped Screw B3 x 8
054B	6	6	6	6	2991259010	Bushing
918B	1	1	1	1	3889861010	Label
918B	1	1	1	1	4113861020	Label
919B	1	1	1	1	2932861010	Label
919B	1	1	1	1	2911861140	Label

REF. DESIG.	Q'TY				PART NO.	DESCRIPTION
	U	C	N	A		
006F	3	3	3	3	51100306A9	B.H.M. Screw B3 x 6
030F	1	1	1	1	4214105510	Chassis (K)
035F	1	1	1	1	4214257020	Lid
036F	4	4	4	4	51280306B0	B.H. Tapped Screw B3 x 6
980F	5	5	5	5	4214005010	Clamper
960F	1	1	1	1	4277160010	Bracket
961F	2	2	2	2	51100306A9	B.H.M. Screw B3 x 6
990F	8	8	8	8	4277118010	Spacer

9.4 [P04-99] ASSOCIATED MECHANISM FOR CASSETTE TAPE OPERATION

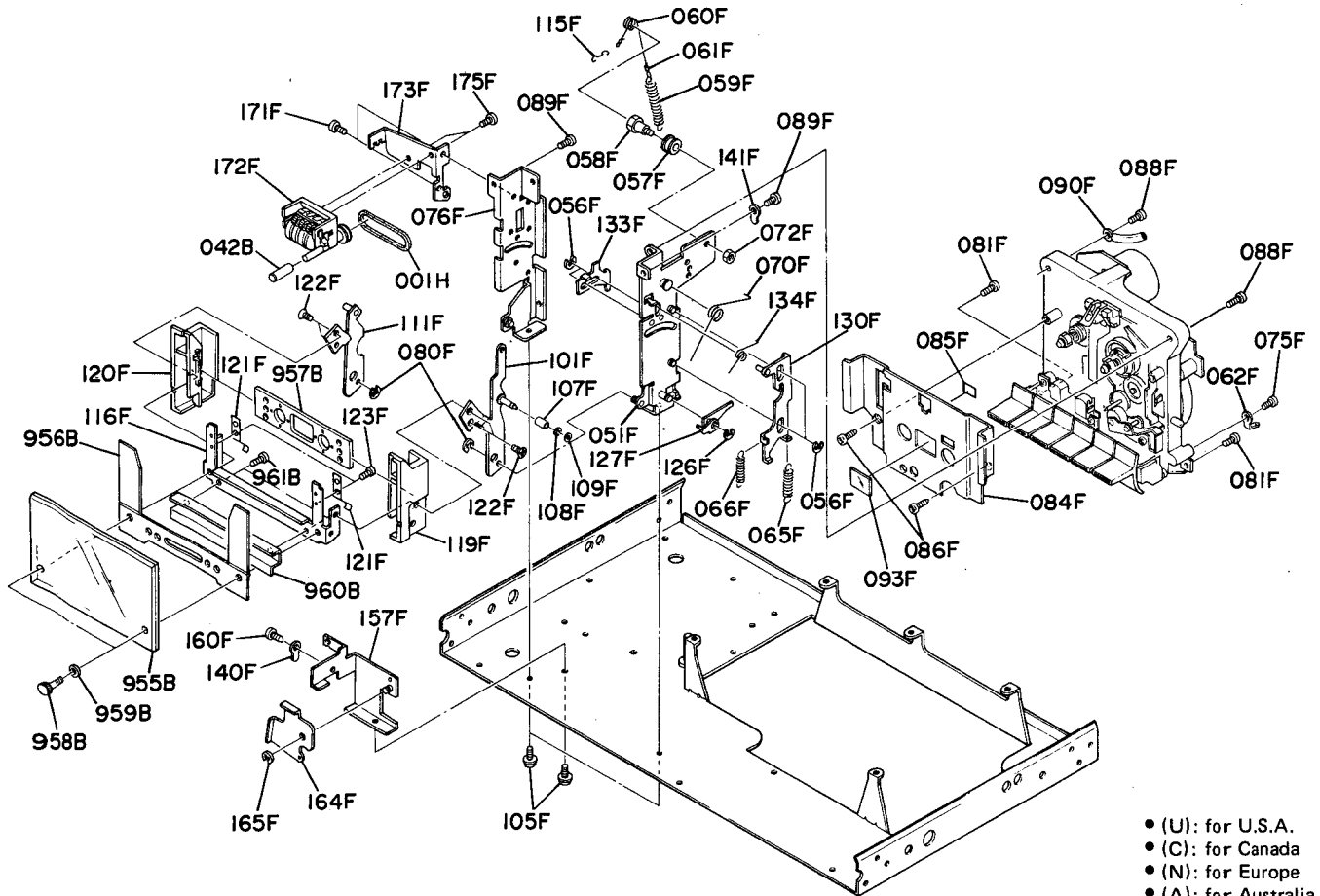

- (U): for U.S.A.
- (C): for Canada
- (N): for Europe
- (A): for Australia

REF. DESIG.	Q'TY				PART NO.	DESCRIPTION
	U	C	N	A		
042B	1	1	1	1	3348067060	Cap, Counter
955B	1	1	1	1	4276158050	Window
956B	1	1	1	1	4276063030	Escutcheon
957B	1	1	1	1	4276063040	Escutcheon
958B	2	2	2	2	4276112010	Shaft
959B	2	2	2	2	59046502G9	Washer
960B	1	1	1	1	4276053010	Cover
961B	2	2	2	2	51380206T0	P.H. Tapped Screw P2 x 6
051F	1	1	1	1	4265160520	Bracket, K (R)
056F	4	4	4	4	64000200R0	RG Ring, E Type
057F	1	1	1	1	4197262010	Pulley
058F	1	1	1	1	4197112040	Shaft
059F	1	1	1	1	4197115020	Spring
060F	1	1	1	1	72081604A0	String (20)
061F	1	1	1	1	56382540G0	Eyelet
062F	1	1	1	1	62031650W0	Lug
065F	1	1	1	1	4265115030	Spring
066F	1	1	1	1	4265115040	Spring
085F	1	1	1	1	4265118010	Spacer
070F	1	1	1	1	4197115030	Spring
072F	1	1	1	1	53110303A9	Hexagon Nut
075F	1	1	1	1	51300306B0	P.H. Tapped Screw B3 x 6
076F	1	1	1	1	4265160530	Bracket, K (L)
080F	2	2	2	2	64000200R0	RG Ring, E Type
081F	2	2	2	2	51060306A9	P.H. Tapped Screw B3 x 6
084F	1	1	1	1	4265053030	Cover
086F	2	2	2	2	51382606K0	P.H. Tapped Screw P2.6 x 6
088F	2	2	2	2	51100308A9	B.H.M. Screw B3 x 8
089F	2	2	2	2	51100306A9	B.H.M. Screw B3 x 6

REF. DESIG.	Q'TY				PART NO.	DESCRIPTION
	U	C	N	A		
107F	1	1	1	1	4265055010	Collar
090F	1	1	1	1	1382005030	Clamper
093F	1	1	1	1	4276274010	Reflector
101F	1	1	1	1	4265002550	Arm, K (R)
105F	3	3	3	3	51470306A9	L. Washer Screw L3 x 6
111F	1	1	1	1	4265002540	Arm, K (L)
115F	1	1	1	1	4197258030	Hook
116F	1	1	1	1	4265160110	Bracket
119F	1	1	1	1	4265271010	Holder (R)
120F	1	1	1	1	4265271020	Holder (L)
121F	2	2	2	2	4265115050	Spring
108F	1	1	1	1	64000200R0	RG Ring, E type
122F	4	4	4	4	51042605S0	F.H.M. Screw F2.6 x 5
123F	2	2	2	2	51062605S0	P.H.M. Screw P2.6 x 5
126F	1	1	1	1	64002500R0	RG Ring, E Type
127F	1	1	1	1	4265002520	Arm, Inter Look
130F	1	1	1	1	4265258510	Hook
133F	1	1	1	1	4265354010	Lever
134F	1	1	1	1	4265115070	Spring
140F	1	1	1	1	62031650W0	Lug
141F	1	1	1	1	62031650W0	Lug
157F	1	1	1	1	4197104510	Retainer
109F	1	1	1	1	64020200Q0	RG Ring, CS type
160F	1	1	1	1	51100304A9	B.H.M. Screw B3 x 6
164F	1	1	1	1	4197354050	Lever
165F	1	1	1	1	64000300R0	RG Ring, E Type
171F	2	2	2	2	51100304A9	B.H.M. Screw B3 x 4
172F	1	1	1	1	4276052010	Counter
173F	1	1	1	1	4263160010	Bracket
175F	2	2	2	2	51100306A9	B.H.M. Screw B3 x 6
001H	1	1	1	1	4276264010	Belt

9.5 [P05-99] REAR PANEL

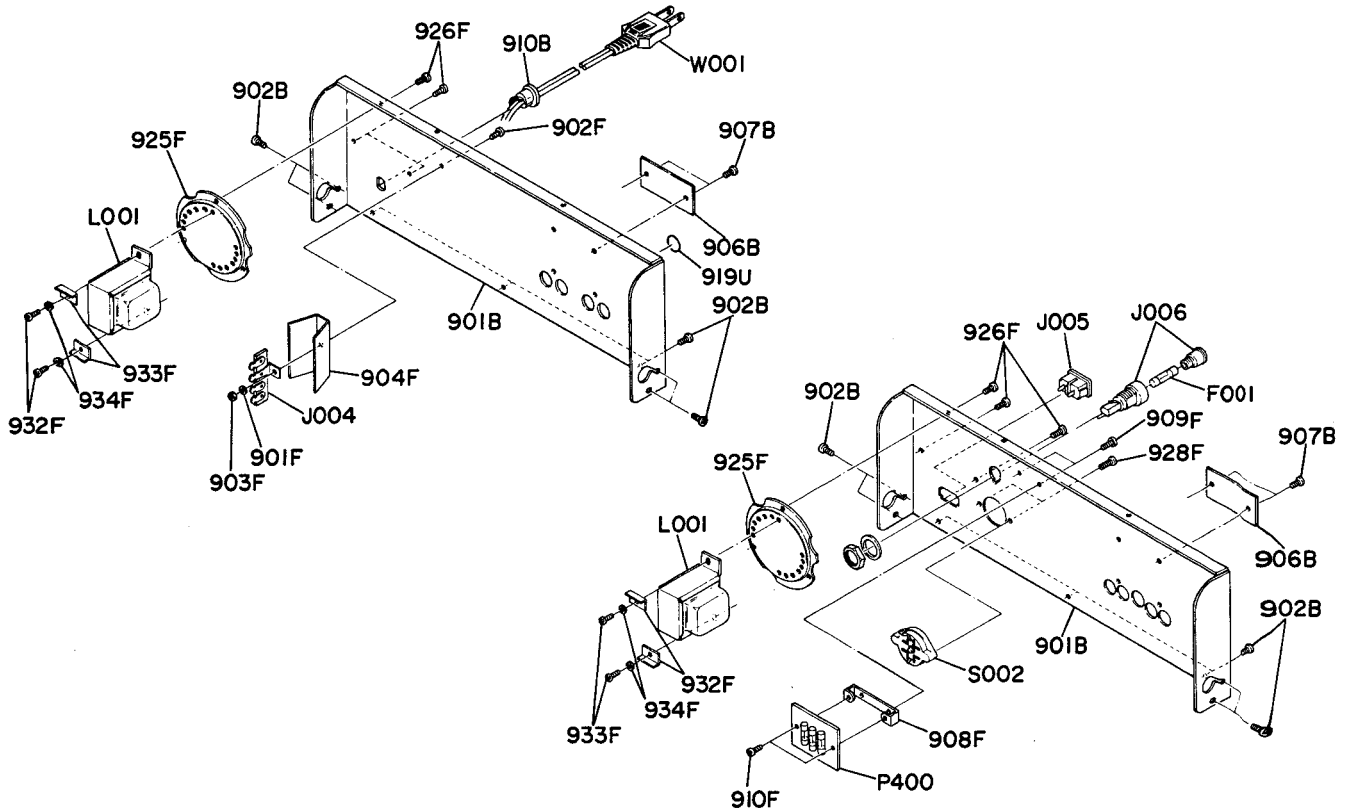

- (U): for U.S.A.
- (C): for Canada
- (N): for Europe
- (A): for Australia

REF. DESIG.	Q'TY				PART NO.	DESCRIPTION
	U	C	N	A		
901B	1	1			4214160020	Bracket, Rear Panel
901B			1	1	4265160040	Bracket, Rear Panel
902B	7	7	7	7	51280306U0	B.H. Tapped Screw B3 x 6
906B	1				4277265010	Indicator
906B		1			4277265020	Indicator
906B			1		4277265030	Indicator
906B				1	4277265050	Indicator
907B	2	2	2	2	51760306B0	OS. Tapped Screw 3 x 6
910B	1	1			1455259030	Bushing
901F	1	1			54040302A0	Spring Washer
902F	1	1			51100306S9	B.H.M. Screw B3 x 6
903F	1	1			53110303A9	Hexagon Nut
904F	1	1			4114120010	Insulator
908F			1	1	3889160110	Bracket
909F		2	2		51100306S9	B.H.M. Screw B3 x 6
910F		2	2		51100306A9	B.H.M. Screw B3 x 6
925F	1	1	1	1	4265160060	Bracket
926F	3	3	3	3	51100306S9	B.H.M. Screw B3 x 6
928F		2	2		51280310U0	B.H. Tapped Screw B3 x 10
932F	2	2			51300408B0	P.H. Tapped Screw P4 x 8
932F			2	2	4265005010	Clamper
933F	2	2			4265005010	Clamper
933F			2	2	51300408B0	P.H. Tapped Screw P4 x 8
934F	2	2	2	2	54040402A0	Spring Washer

REF. DESIG.	Q'TY				PART NO.	DESCRIPTION
	U	C	N	A		
△ F001			1	1	FS10012800	Fuse 125mAT
△ J004	1	1			YL01040160	Terminal (4P)
△ J005		1	1		YP04000580	Plug, AC Inlet
△ J006		1	1		YJ08000290	Jack, Fuse Holder
△ L001	1	1			TS15406140	Power Transformer
△ L001			1	1	TS15406180	Power Transformer
△ S002		1	1		BY05080012	Voltage Selector
△ W001	1	1			YC02000140	A.C. Power Cord
919U	1				9511101070	Label UL
919U		1			2457861040	Label CSA

- (U): for U.S.A.
- (C): for Canada
- (N): for Europe
- (A): for Australia

9.6 [P05-00] BUTTONS FOR TAPE OPERATION

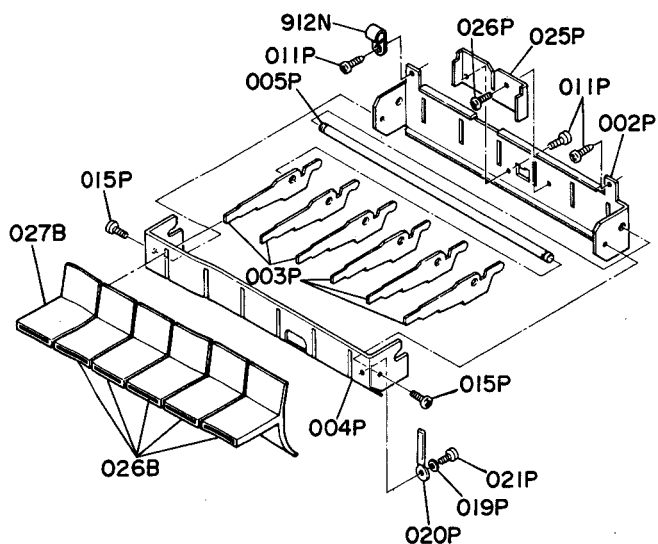

REF. DESIG.	Q'TY				PART NO.	DESCRIPTION
	U	C	N	A		
026B	5	5	5	5	4276270010	Button
027B	1	1	1	1	4276270020	Button, Rec
002P	1	1	1	1	4380160010	Bracket
003P	6	6	6	6	4380354070	Lever
004P	1	1	1	1	4380051010	Guide
005P	1	1	1	1	4380112030	Shaft
011P	3	3	3	3	51300310B0	P.H. Tapped Screw P3 x 10
015P	2	2	2	2	51062603A0	P.H.M. Screw P2.6 x 3
019P	1	1	1	1	54052600R0	T.L. Washer OR
020P	1	1	1	1	1210005010	Clamper
021P	1	1	1	1	51062604A0	P.H.M. Screw P2.6 x 4
025P	1	1	1	1	4383104040	Retainer
026P	1	1	1	1	51062603A0	P.H.M. Screw P2.6 x 3
912N	1	1	1	1	1126005010	Clamper

9.7 [P06-99] HEAD CHASSIS

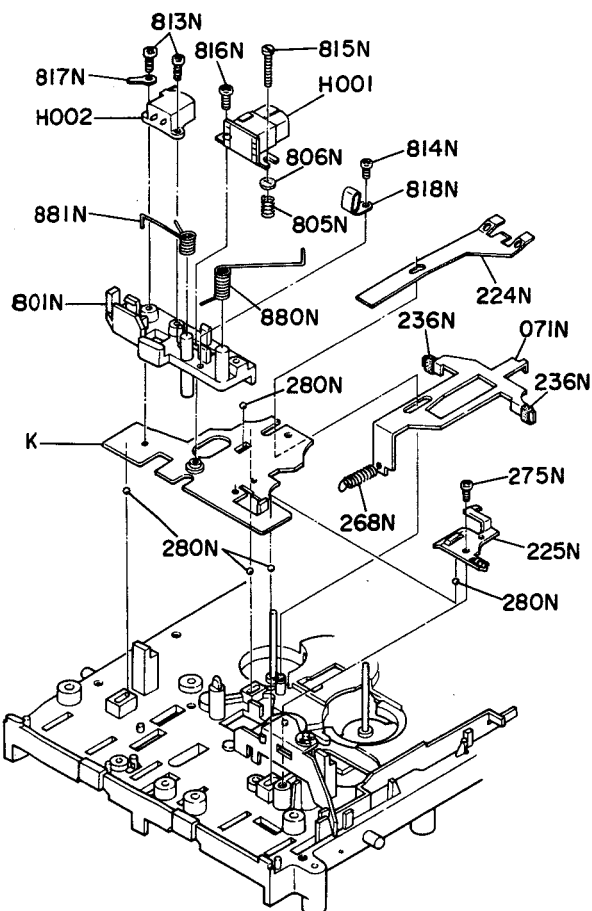

REF. DESIG.	Q'TY				PART NO.	DESCRIPTION
	U	C	N	A		
K	1	1	1	1	4411105400	Chassis Assembly, Head
224N	1	1	1	1	4380115130	Spring
225N	1	1	1	1	4367115170	Spring
275N	1	1	1	1	51300308B0	P.H. Tapped Screw P3 x 8
280N	5	5	5	5	61020010T0	Ball
801N	1	1	1	1	4411160010	Bracket
805N	1	1	1	1	4383115030	Spring
806N	1	1	1	1	3444118070	Spacer
813N	2	2	2	2	51100212A0	B.H.M. Screw B2 x 12
814N	1	1	1	1	51100210A0	B.H.M. Screw B2 x 10
815N	1	1	1	1	4397254090	Pin
816N	1	1	1	1	51100206A0	B.H.M. Screw B2 x 6
817N	1	1	1	1	62021030W0	Lug
818N	1	1	1	1	4411005010	Clamper
880N	1	1	1	1	4383115020	Spring
881N	1	1	1	1	4367115050	Spring
H001	1	1	1	1	LH82132010	Rec./Play Head
H002	1	1	1	1	LH31000510	Erase Head

- (U): for U.S.A.
- (C): for Canada
- (N): for Europe
- (A): for Australia

9.8 [P07-99] FLYWHEEL

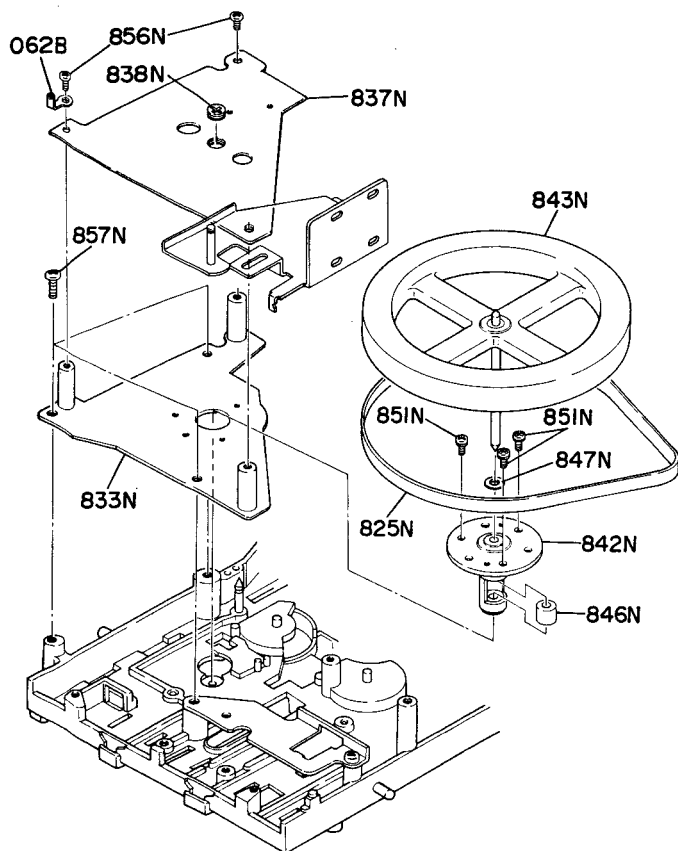

REF. DESIG.	Q'TY				PART NO.	DESCRIPTION
	U	C	N	A		
L	1	1	1	1	4383106400	Sustainer Assembly, Capstan
842N	1	1	1	1	4383106020	Sustainer
843N	1	1	1	1	4383273510	Flywheel
846N	1	1	1	1	4383262020	Pulley
847N	2	2	2	2	59264702G9	Washer
825N	1	1	1	1	4383264020	Belt
833N	1	1	1	1	4383104420	Retainer Assembly
837N	1	1	1	1	4383104060	Retainer
838N	1	1	1	1	3483164020	Adjuster
851N	3	3	3	3	51140306A9	O.C.H.M. Screw B3 x 6
856N	2	2	2	2	51060308A9	P.H.M. Screw P3 x 8
857N	3	3	3	3	51300312B0	P.H. Tapped Screw .P3 x 12
062B	1	1	1	1	62030049W0	Lug

9.9 [P08-99] SWITCH LOCATION FOR TAPE OPERATION

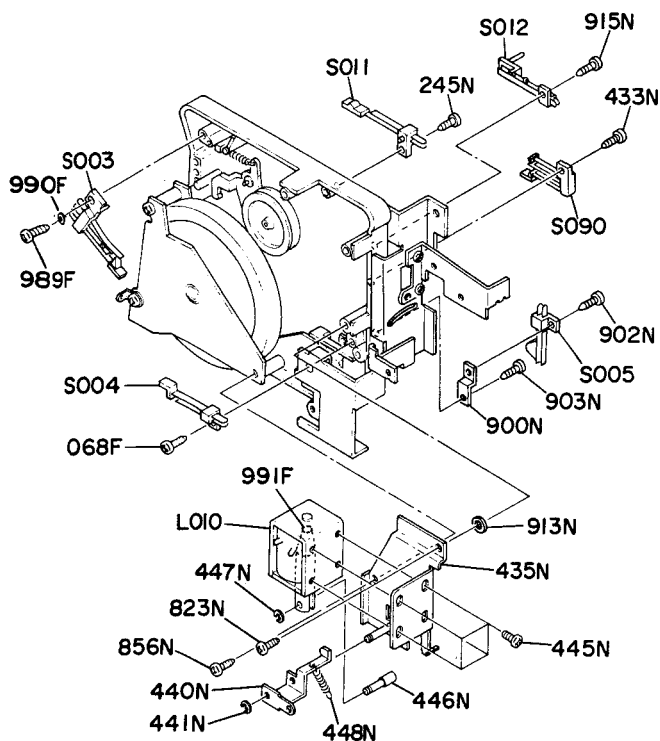

REF. DESIG.	Q'TY				PART NO.	DESCRIPTION
	U	C	N	A		
068F	1	1	1	1	51380206P0	P.H. Tapped Screw P2 x 6
989F	1	1	1	1	51302610B0	P.H. Tapped Screw P2.6 x 10
245N	1	1	1	1	51302608B0	B.H.M. Screw P2.6 x 8
433N	1	1	1	1	51302608B0	P.H. Tapped Screw P2.6 x 8
435N	1	1	1	1	4198160500	Bracket
440N	1	1	1	1	4198002010	Arm
441N	1	1	1	1	64002500R0	RG Ring, E Type
445N	2	2	2	2	51100305A9	B.H.M. Screw
446N	1	1	1	1	4198254020	Pin
447N	1	1	1	1	64001500R0	RG Ring, E Type
448N	1	1	1	1	4198115010	Spring
823N	1	1	1	1	51300310B0	P.H. Tapped Screw P3 x 10
856N	1	1	1	1	51060308A9	P.H.M. Screw P3 x 8
913N	1	1	1	1	54020401A0	Flat Washer, P.
900N	1	1	1	1	4411160020	Bracket
902N	1	1	1	1	51062608A9	P.H.M. Screw P2.6 x 8
903N	1	1	1	1	51300306B0	P.H. Tapped Screw P3 x 6
915N	1	1	1	1	51302608B0	P.H. Tapped Screw P2.6 x 8
L010	1	1	1	1	ME10530040	Solenoid Coil
S003	1	1	1	1	SM02010120	Mini Switch, Pause Muting
S004	1	1	1	1	SM01010660	Mini Switch, Play Muting
S005	1	1	1	1	SM01010510	Mini Switch, Play Start
S011	1	1	1	1	SM01010750	Mini Switch, Motor
S012	1	1	1	1	SM01010740	Mini Switch, Cassette
S090	1	1	1	1	SM02020080	Mini Switch, Skid/FREW
991F	1	1	1	1	4276118020	Spacer
990F	1	1	1	1	54052600A0	T.L. Washer OR

9.10 [P09-99] PARTS ASSEMBLED ON TOP OF CHASSIS

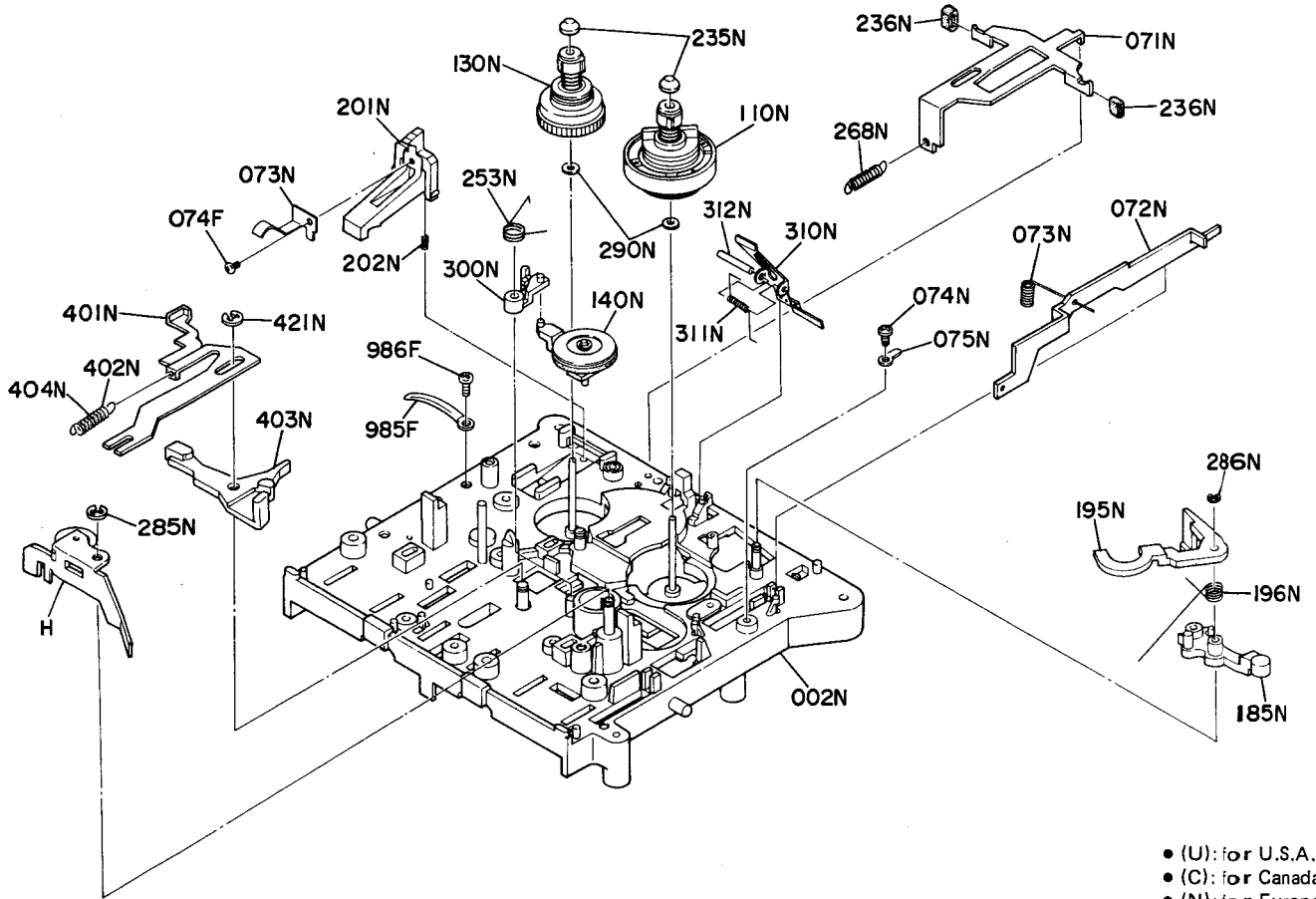

- (U): for U.S.A.
- (C): for Canada
- (N): for Europe
- (A): for Australia

REF. DESIG.	Q'TY				PART NO.	DESCRIPTION
	U	C	N	A		
H	1	1	1	1	4383002410	Arm Assembly, Pinch Roller
002N	1	1	1	1	4380105400	Chassis Assembly
110N	1	1	1	1	4367004400	Table Assembly, Takeup
130N	1	1	1	1	4367004410	Table Assembly, Supply
140N	1	1	1	1	4367002420	Arm Assembly, Takeup
185N	1	1	1	1	4380354460	Lever Assembly, TMS
071N	1	1	1	1	4367354090	Lever
072N	1	1	1	1	4367354120	Lever
073N	1	1	1	1	4380115120	Spring
074N	1	1	1	1	51302606U0	P.H. Tapped Screw B2.6 x 6
075N	1	1	1	1	62261240W0	Lug
195N	1	1	1	1	4367002050	Arm
196N	1	1	1	1	4367115130	Spring
201N	1	1	1	1	4367354080	Lever
202N	1	1	1	1	4380115060	Spring
235N	2	2	2	2	4367067010	Cap
236N	2	2	2	2	4367263010	Brake
253N	1	1	1	1	4367115310	Spring
268N	1	1	1	1	4367115210	Spring
285N	1	1	1	1	64002500R0	RG Ring, E Type
286N	1	1	1	1	64001500R0	RG Ring, E Type

REF. DESIG.	Q'TY				PART NO.	DESCRIPTION
	U	C	N	A		
290N	2	2	2	2	59020402G9	Washer
300N	1	1	1	1	4367354110	Lever
310N	1	1	1	1	4383115010	Spring
311N	1	1	1	1	4380115030	Spring
312N	1	1	1	1	4380112010	Shaft
401N	1	1	1	1	4398354010	Lever
402N	1	1	1	1	4398115010	Spring
403N	1	1	1	1	4367002090	Arm
404N	1	1	1	1	4367056050	Buffer
421N	1	1	1	1	64002500R0	RG Ring, E Type
073F	1	1	1	1	4197115060	Spring
074F	1	1	1	1	51302606U0	P.H. Tapped Screw

9.11 [P10-99] PARTS ASSEMBLED ON REVERSE OF CHASSIS

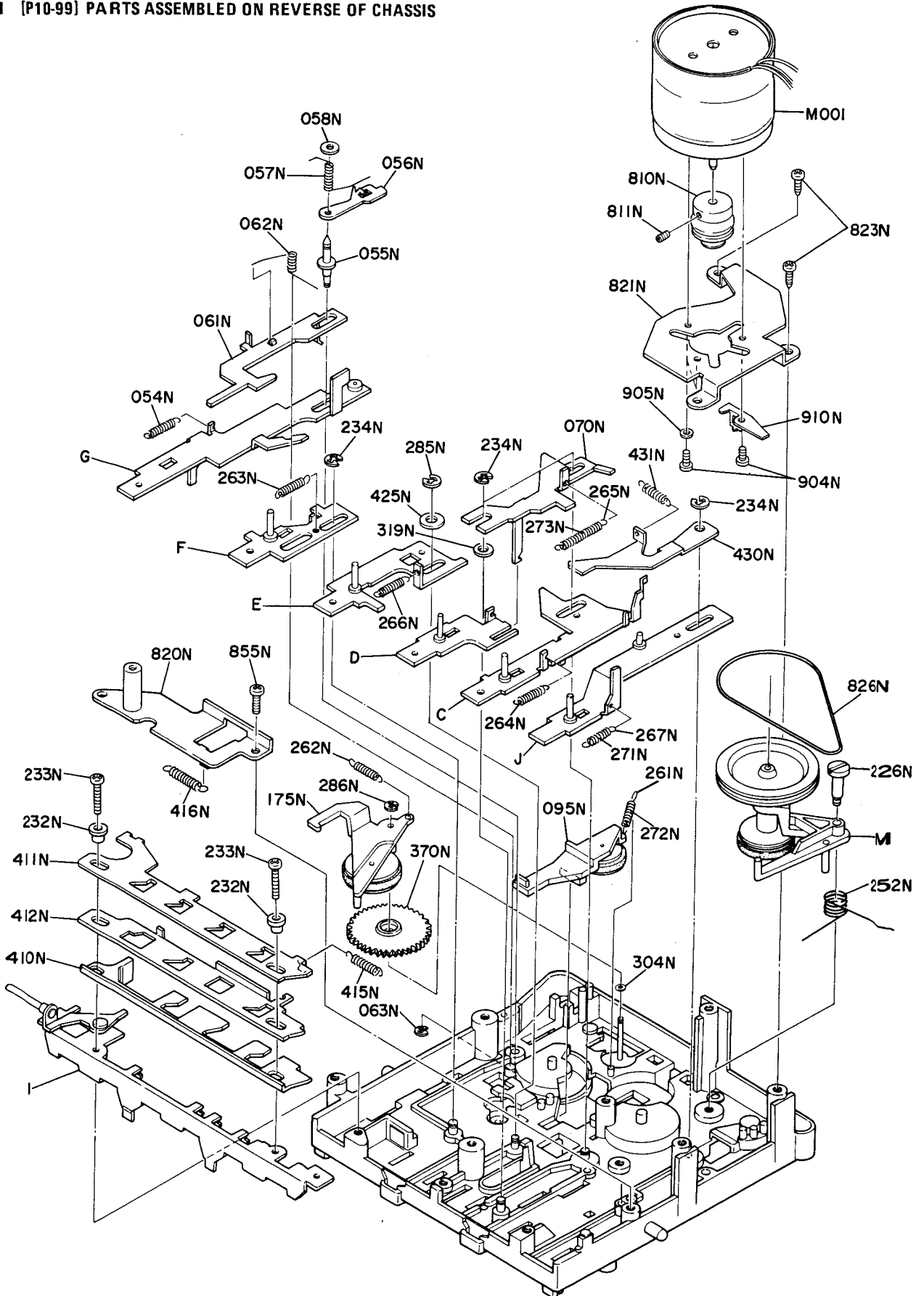

- (U): for U.S.A.
- (C): for Canada
- (N): for Europe
- (A): for Australia

REF. DESIG.	Q'TY				PART NO.	DESCRIPTION
	U	C	N	A		
C	1	1	1	1	4380354400	Lever Assembly, Rew
D	1	1	1	1	4380354410	Lever Assembly, Play
E	1	1	1	1	4380354420	Lever Assembly, F.F
F	1	1	1	1	4380354430	Lever Assembly, Stop
G	1	1	1	1	4380354440	Lever Assembly, Pause
I	1	1	1	1	4383051400	Guide Assembly
J	1	1	1	1	4399354400	Lever Assembly, Rec
M	1	1	1	1	4380001400	Idler Assembly
095N	1	1	1	1	4367354450	Lever Assembly, F.F
175N	1	1	1	1	4367002410	Arm Assembly, Tms
054N	1	1	1	1	4367115210	Spring
055N	1	1	1	1	4367112130	Shaft
056N	1	1	1	1	4367054030	Cam, Pause Lock
057N	1	1	1	1	4367115140	Spring
058N	1	1	1	1	59020805G9	Washer
061N	1	1	1	1	4367354070	Lever
062N	1	1	1	1	4380115080	Spring
063N	1	1	1	1	64001500R0	RG Ring, E Type
070N	1	1	1	1	4367354160	Lever, Head Chassis
820N	1	1	1	1	4383160020	Bracket
821N	1	1	1	1	4383160010	Bracket, Motor
823N	2	2	2	2	51300310B0	P.H. Tapped Screw P3 x 10
826N	1	1	1	1	4380264050	Belt, TMS
226N	1	1	1	1	4367112180	Shaft
232N	2	2	2	2	4382055010	Collar
233N	2	2	2	2	51300312B0	P.H. Tapped Screw P3 x 12
234N	4	4	4	4	64000300R0	RG Ring, E Type
252N	1	1	1	1	4380115050	Spring
261N	1	1	1	1	4367115090	Spring
262N	1	1	1	1	4367115120	Spring
263N	1	1	1	1	4367115250	Spring
264N	1	1	1	1	4367115340	Spring
265N	1	1	1	1	4367115270	Spring
266N	1	1	1	1	4367115280	Spring

REF. DESIG.	Q'TY				PART NO.	DESCRIPTION
	U	C	N	A		
267N	1	1	1	1	4380115070	Spring
271N	1	1	1	1	4367056020	Buffer
272N	1	1	1	1	4367056030	Buffer
273N	1	1	1	1	4367056020	Buffer
285N	1	1	1	1	64002500R0	RG Ring, E Type
286N	1	1	1	1	64001500R0	RG Ring, E Type
304N	1	1	1	1	4367118060	Spacer
319N	1	1	1	1	59046501G9	Washer
370N	1	1	1	1	4367058500	Gear (K)
410N	1	1	1	1	4396054010	Cam, Stop/Eject
411N	1	1	1	1	4396054020	Cam, Rec Lock
412N	1	1	1	1	4399054010	Cam, Lock
415N	1	1	1	1	4396115030	Spring
416N	1	1	1	1	4396115030	Spring
425N	1	1	1	1	54110159A0	Flat Washer, L.
430N	1	1	1	1	4399002010	Arm
431N	1	1	1	1	4399115010	Spring
810N	1	1	1	1	4411262010	Pulley
811N	1	1	1	1	51690305Q9	Socket Screw, HP. 3 x 5
855N	1	1	1	1	51300308B0	P.H. Tapped Screw P3 x 8
904N	3	3	3	3	51062603A0	P.H.M. Screw P2.6 x 3
905N	2	2	2	2	54012600E0	Flat Washer, S.
910N	1	1	1	1	4398002010	Arm, Motor
M001	1	1	1	1	MM11205010	D.C. Motor Servo 12V 1800/3600 rpm

9.12 [M01-99] P.W. BOARD & GENERAL PARTS

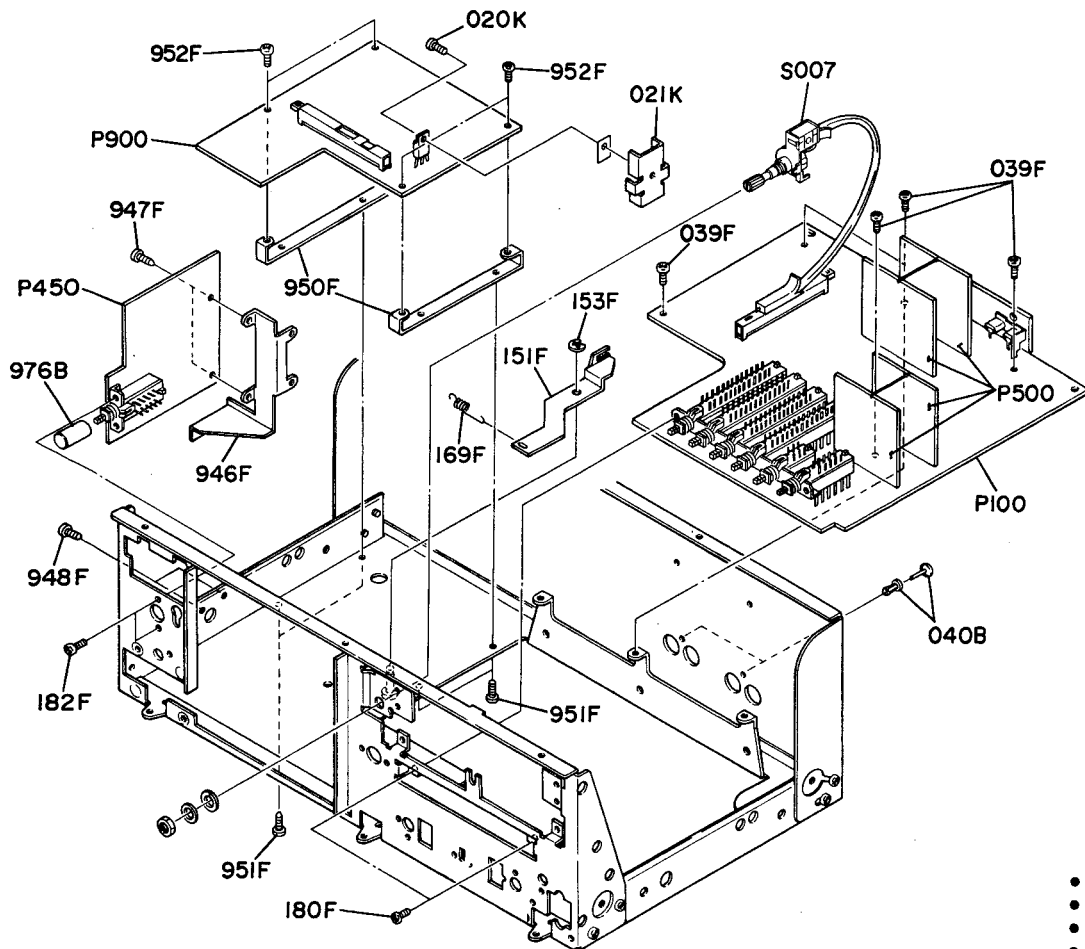

- (U): for U.S.A.
- (C): for Canada
- (N): for Europe
- (A): for Australia

REF. DESIG.	QTY				PART NO.	DESCRIPTION
	U	C	N	A		
040B	2	2	2	2	2965005010	Clamper
976B	1	1	1	1	3448154060	Knob, Skip
039F	5	5	5	5	51100306A9	B.H.M. Screw B3 x 6
151F	1	1	1	1	4277002010	Arm, Rec
153F	1	1	1	1	64000300R0	RG Ring, E Type
169F	1	1	1	1	4277115010	Spring
180F	2	2	2	2	51100306A9	B.H.M. Screw B3 x 6
182F	2	2	2	2	51100306A9	B.H.M. Screw B3 x 6
946F	1	1	1	1	4277160020	Bracket

REF. DESIG.	QTY				PART NO.	DESCRIPTION
	U	C	N	A		
947F	2	2	2	2	51280306B0	B.H. Tapped Screw B3 x 6
948F	2	2	2	2	51280306B0	B.H. Tapped Screw B3 x 6
950F	2	2	2	2	3889160090	Bracket
951F	4	4	4	4	51100306A9	B.H.M. Screw B3 x 6
952F	4	4	4	4	51100306A9	B.H.M. Screw B3 x 6
020K	1	1	1	1	51100306S9	B.H.M. Screw B3 x 6
021K	1	1	1	1	3444267013	Heatsink
S007	1	1	1	1	SC00020020	Switch, Speed Change

9.13 [H01-99] PACKING MATERIALS

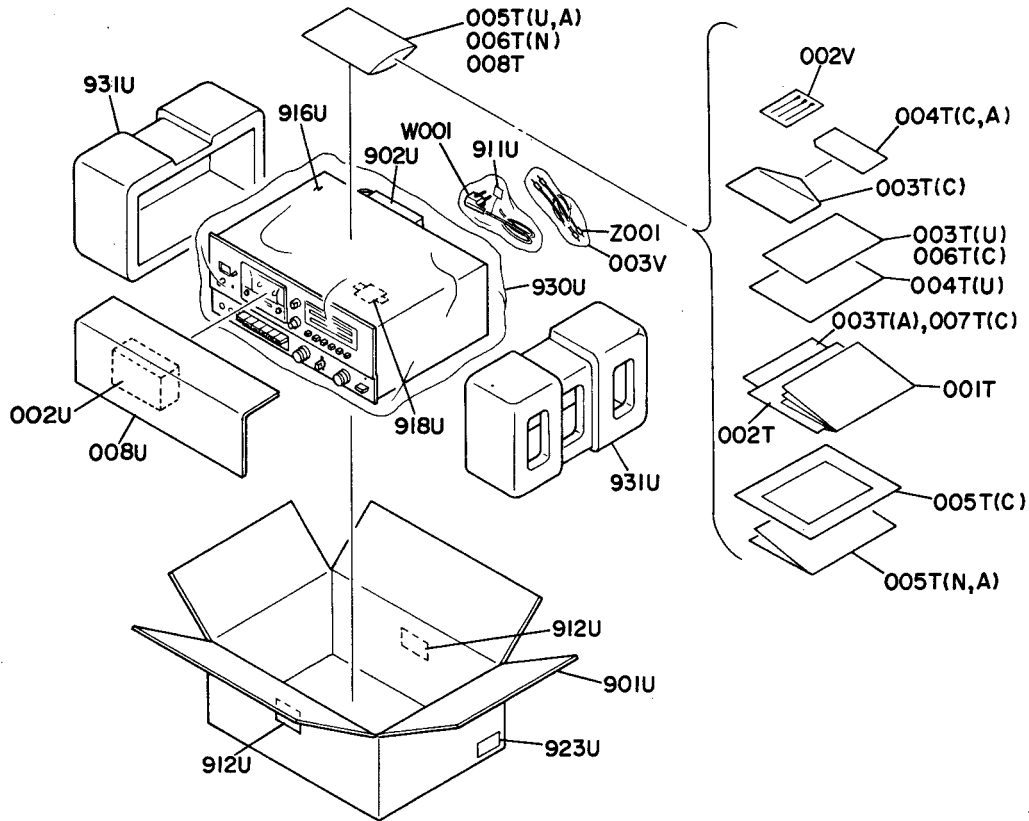

- (U): for U.S.A.
- (C): for Canada
- (N): for Europe
- (A): for Australia

REF. DESIG.	Q'TY				PART NO.	DESCRIPTION
	U	C	N	A		
001T	1			1	4276851010	Instructions
001T		1	1		4276851310	Instructions
002T	1			1	4277851020	Instructions
002T		1			4277851050	Instructions
002T			1		4277851030	Instructions
003T	1				2818854020	Guarantee Card
003T		1			2918813010	Envelope
003T				1	2205851040	Instructions
004T	1				2225813010	Envelope
004T		1			9630000180	Guarantee Card
004T				1	9631000090	Guarantee Card
005T	1			1	9013025010	Polyethy Bag
005T		1			9650000050	S. Station Card
005T			1		4277856010	Circuit Diagram
006T		1			2818854040	Guarantee Card
006T			1		9013025010	Polyethy Bag
007T		1			4292851220	Instructions
008T		1			9013025010	Polyethy Bag
008U	1	1	1	1	4277807010	Reinforcing

REF. DESIG.	Q'TY				PART NO.	DESCRIPTION
	U	C	N	A		
931U	2	2	2	2	4214809030	Cushion
002U	1	1	1	1	4265807010	Reinforcing
901U	1	1		1	4277801010	Packing Case
901U			1		4277801030	Packing Case
902U	1	1			2864804010	Sleeve
911U			1	1	9560000040	Hang Tag
912U		2			9510901020	Label
916U	1	1	1	1	2918107190	Sheet
918U			1		2731821010	Silicagel
919U	1				9511101070	Label
919U		1			2457861040	Label
923U	2				9526019010	Serial No. Card
923U		2			9526019020	Serial No. Card
923U			2	2	9526019030	Serial No. Card
930U	1	1	1	1	9090909040	Polyethy Sheet
002V	1	1	1	1	4136071010	Cleaner
003V	1	1	1	1	9011325010	Polyethy Bag
△ W001				1	ZC01805010	A.C. Power Cord
△ W001				1	ZC02006020	A.C. Power Cord
Z001	2	2	2	2	ZD01000170	Connective Cord

- (U): for U.S.A.
- (C): for Canada
- (N): for Europe
- (A): for Australia

9.14 ELECTRICAL PARTS

REF. DESIG.	Q'TY				PART NO.	DESCRIPTION				
	U	C	N	A						
P100	1	1	1	1	YK42771210	P100-PRE-AMP.				
	1	1			ZZ42771210	CIRCUIT BOARD				
			1	1	ZZ42778210	P.W. Board, Pre-Amp. P.W. Board Assembly P.W. Board Assembly				
P100-CAPACITORS										
C101	1	1	1	1	EE10505040	Elect	1μF	50V		
C102	1	1	1	1	DF15392300	Film	3900pF	±5%		
C103	1	1	1	1	DF15152300	Film	1500pF	±5%		
C104	1	1	1	1	DF65681010	Film	680pF	±5%		
C105	1	1	1	1	EA10602530	Elect	10μF	25V		
C106	1	1	1	1	EA10505030	Elect	1μF	50V		
C107	1	1	1	1	EA47503530	Elect	4.7μF	35V		
C108	1	1	1	1	DF15272300	Film	2700pF	±5%		
C109	1	1	1	1	EA22405030	Elect	0.22μF	50V		
C110	1	1	1	1	EA10602530	Elect	10μF	25V		
C111	1	1	1	1	DF15563300	Film	0.056μF	±5%		
C112	1	1	1	1	DF15562300	Film	5600pF	±5%		
C113	1	1	1	1	DF15473300	Film	0.047μF	±5%		
C114	1	1	1	1	DF15103300	Film	0.01μF	±5%		
C115	1	1	1	1	DF15272300	Film	2700pF	±5%		
C116	1	1	1	1	DF15183300	Film	0.018μF	±5%		
C117	1	1	1	1	DF15183300	Film	0.018μF	±5%		
C118	1	1	1	1	DF15183300	Film	0.018μF	±5%		
C119	1	1	1	1	DF15223300	Film	0.022μF	±5%		
C120	1	1	1	1	DF15223300	Film	0.022μF	±5%		
C121	1	1	1	1	DF15333300	Film	0.033μF	±5%		
C122	1	1	1	1	DF15103300	Film	0.01μF	±5%		
C123	1	1	1	1	DF15682300	Film	6800pF	±5%		
C124	1	1	1	1	DF15682300	Film	6800pF	±5%		
C125	1	1	1	1	DF15682300	Film	6800pF	±5%		
C126	1	1	1	1	DF15822300	Film	8200pF	±5%		
C151	1	1	1	1	DF65151010	Film	150pF	±5%		
C152	1	1	1	1	EE10601640	Elect	10μF	16V		
C153	1	1	1	1	EA10602530	Elect	10μF	25V		
C154	1	1	1	1	DD15470300	Ceramic	47pF	±5%		
C155	1	1	1	1	DD15300300	Ceramic	30pF	±5%		
C156	1	1	1	1	EA10701030	Elect	100μF	10V		
C157	1	1	1	1	DF15123300	Film	0.012μF	±5%		
C158	1	1	1	1	EA22505030	Elect	2.2μF	50V		
C159	1	1	1	1	EA10505030	Elect	1μF	50V		
C160	1	1	1	1	EA47405030	Elect	0.47μF	50V		
C161	1	1	1	1	DF15822300	Film	8200pF	±5%		
C162	1	1	1	1	EA47405030	Elect	0.47μF	50V		
C163	1	1	1	1	DF15123300	Film	0.012μF	±5%		
C165	1	1	1	1	EE10505040	Elect	1μF	50V		
△ C166	1	1	1	1	EA33602530	Elect	33μF	25V		
C167	1	1	1	1	DF15152300	Film	1500pF	±5%		
C168	1	1	1	1	DF55361090	Film	360pF	±5%		
C169	1	1	1	1	DF55681090	Film	680pF	±5%		
C170	1	1	1	1	EA10505030	Elect	1μF	50V		
C171	1	1	1	1	DD15471370	Ceramic	470pF	±5%		
C172	1	1	1	1	EA47602530	Elect	47μF	25V		
C201	1	1	1	1	EE10505040	Elect	1μF	50V		
C202	1	1	1	1	DF15392300	Film	3900pF	±5%		
C203	1	1	1	1	DF15152300	Film	1500pF	±5%		
C204	1	1	1	1	DF65681010	Film	680pF	±5%		
C205	1	1	1	1	EA10602530	Elect	10μF	25V		
C206	1	1	1	1	EA10505030	Elect	1μF	50V		
C207	1	1	1	1	EA47503530	Elect	4.7μF	35V		
C208	1	1	1	1	DF15272300	Film	2700pF	±5%		
C209	1	1	1	1	EA22405030	Elect	0.22μF	50V		
C210	1	1	1	1	EA10602530	Elect	10μF	25V		
C211	1	1	1	1	DF15563300	Film	0.056μF	±5%		
C212	1	1	1	1	DF15562300	Film	5600pF	±5%		
C213	1	1	1	1	DF15473300	Film	0.047μF	±5%		
C214	1	1	1	1	DF15103300	Film	0.01μF	±5%		
C215	1	1	1	1	DF15272300	Film	2700pF	±5%		
C216	1	1	1	1	DF15183300	Film	0.018μF	±5%		
C217	1	1	1	1	DF15183300	Film	0.018μF	±5%		
C218	1	1	1	1	DF15183300	Film	0.018μF	±5%		
C219	1	1	1	1	DF15223300	Film	0.022μF	±5%		
C220	1	1	1	1	DF15223300	Film	0.022μF	±5%		
C221	1	1	1	1	DF15333300	Film	0.033μF	±5%		
C222	1	1	1	1	DF15103300	Film	0.01μF	±5%		
C223	1	1	1	1	DF15682300	Film	6800pF	±5%		
C224	1	1	1	1	DF15682300	Film	6800pF	±5%		
C225	1	1	1	1	DF15682300	Film	6800pF	±5%		
C226	1	1	1	1	DF15822300	Film	8200pF	±5%		
C251	1	1	1	1	DF65151010	Film	150pF	±5%		
C252	1	1	1	1	EE10601640	Elect	10μF	16V		
C253	1	1	1	1	EA10602530	Elect	10μF	25V		
C254	1	1	1	1	DD15470300	Ceramic	47pF	±5%		
C255	1	1	1	1	DD15300300	Ceramic	30pF	±5%		
C256	1	1	1	1	EA10701030	Elect	100μF	10V		
C257	1	1	1	1	DF15123300	Film	0.012μF	±5%		
C258	1	1	1	1	EA22505030	Elect	2.2μF	50V		
C259	1	1	1	1	EA10505030	Elect	1μF	50V		
C260	1	1	1	1	EA47405030	Elect	0.47μF	50V		
C261	1	1	1	1	DF15822300	Film	8200pF	±5%		
C262	1	1	1	1	EA47405030	Elect	0.47μF	50V		
C263	1	1	1	1	DF15123300	Film	0.012μF	±5%		
C265	1	1	1	1	EE10505040	Elect	1μF	50V		
△ C266	1	1	1	1	EA33602530	Elect	33μF	25V		
C267	1	1	1	1	DF15152300	Film	1500pF	±5%		
C268	1	1	1	1	DF55361090	Film	360pF	±5%		
C269	1	1	1	1	DF55681090	Film	680pF	±5%		
C270	1	1	1	1	EA10505030	Elect	1μF	50V		
C271	1	1	1	1	DD15471370	Ceramic	470pF	±5%		
C272	1	1	1	1	EA47602530	Elect	47μF	25V		
C301	1	1	1	1	EA10702530	Elect	100μF	25V		
P100-RESISTORS										
(All Resistors are 5% & 1/4W)										
R101	1	1	1	1	GD05102140		1KΩ			
R103	1	1	1	1	GD05822140		8.2KΩ			
△ R104	1	1	1	1	GG05331140		330Ω			
R106	1	1	1	1	GD05472140		4.7KΩ			
R107	1	1	1	1	GD05562140		5.6KΩ			
R108	1	1	1	1	GD05562140		5.6KΩ			
R109	1	1	1	1	GD05392140		3.9KΩ			
R110	1	1	1	1	GD05562140		5.6KΩ			
R111	1	1	1	1	RA02030060		20KΩ	Trimming		
R112	1	1	1	1	RA02030060		20KΩ	Trimming		
R105	1	1	1	1	GD05182140		1.8KΩ			

- (U): for U.S.A.
- (C): for Canada
- (N): for Europe
- (A): for Australia

REF. DESIG.	Q'TY				PART NO.	DESCRIPTION
	U	C	N	A		
R113	1	1	1	1	GD05105140	1M Ω
R114	1	1	1	1	GD05102140	1K Ω
R115	1	1	1	1	GD05822140	8.2K Ω
R116	1	1	1	1	GD05123140	12K Ω
R117	1	1	1	1	GD05823140	82K Ω
R118	1	1	1	1	GD05334140	330K Ω
R119	1	1	1	1	GD05472140	4.7K Ω
R120	1	1	1	1	GD05102140	1K Ω
R122	1	1	1	1	GD05821140	820 Ω
R123	1	1	1	1	GD05102140	1K Ω
R124	1	1	1	1	GD05102140	1K Ω
R125	1	1	1	1	GD05152140	1.5K Ω
R126	1	1	1	1	GD05101140	100 Ω
R127	1	1	1	1	GD05101140	100 Ω
R128	1	1	1	1	GD05820140	82 Ω
R129	1	1	1	1	GD05660140	56 Ω
R130	1	1	1	1	GD05471140	470 Ω
R131	1	1	1	1	GD05331140	330 Ω
R132	1	1	1	1	GD05102140	1K Ω
R133	1	1	1	1	GD05181140	180 Ω
R134	1	1	1	1	GD05331140	330 Ω
R135	1	1	1	1	GD05391140	390 Ω
R136	1	1	1	1	GD05221140	220 Ω
R137	1	1	1	1	GD05102140	1K Ω
R138	1	1	1	1	GD05102140	1K Ω
R139	1	1	1	1	GD05222140	2.2K Ω
R140	1	1	1	1	GD05102140	1K Ω
R141	1	1	1	1	GD05223140	22K Ω
R142	1	1	1	1	GD05332140	3.3K Ω
R151	1	1	1	1	GD05224140	220K Ω
R152	1	1	1	1	GD05151140	150 Ω
R153	1	1	1	1	GD05104140	100K Ω
R154	1	1	1	1	GD05823140	82K Ω
R155	1	1	1	1	GD05103140	10K Ω
R156	1	1	1	1	GD05271140	270 Ω
R157	1	1	1	1	GD05561140	560 Ω
R158	1	1	1	1	GD05334140	330K Ω
R159	1	1	1	1	GD05682140	6.8K Ω
R160	1	1	1	1	RA05020160	5K Ω Trimming
R161	1	1	1	1	GD05562140	5.6K Ω
R162	1	1	1	1	GD05102140	1K Ω
R163	1	1	1	1	GD05822140	8.2K Ω
R164	1	1	1	1	GD05102140	1K Ω
R165	1	1	1	1	GD05222140	2.2K Ω
R166	1	1	1	1	RA05030090	50K Ω Trimming
R167	1	1	1	1	GG05152140	1.5K Ω
R168	1	1	1	1	GD05102140	1K Ω
R169	1	1	1	1	GD05272140	2.7K Ω
R170	1	1	1	1	GD05333140	33K Ω
△R171	1	1	1	1	GG05331140	330 Ω
R172	1	1	1	1	GD05334140	330K Ω
R173	1	1	1	1	GD05822140	8.2K Ω
R174	1	1	1	1	GA05821010	820 Ω 1W Ω
R175	1	1	1	1	GD05121140	120 Ω
R176	1	1	1	1	GD05102140	1K Ω
R201	1	1	1	1	GD05102140	1K Ω
R203	1	1	1	1	GD05822140	8.2K Ω
△R204	1	1	1	1	GG05331140	330 Ω
R206	1	1	1	1	GD05472140	4.7K Ω
R207	1	1	1	1	GD05562140	5.6K Ω
R205	1	1	1	1	GD05182140	1.8K Ω

REF. DESIG.	Q'TY				PART NO.	DESCRIPTION
	U	C	N	A		
R208	1	1	1	1	GD05562140	5.6K Ω
R209	1	1	1	1	GD05392140	3.9K Ω
R210	1	1	1	1	GD05562140	5.6K Ω
R211	1	1	1	1	RA02030060	20K Ω Trimming
R212	1	1	1	1	RA02030060	20K Ω Trimming
R213	1	1	1	1	GD05105140	1M Ω
R214	1	1	1	1	GD05102140	1K Ω
R215	1	1	1	1	GD05822140	8.2K Ω
R216	1	1	1	1	GD05123140	12K Ω
R217	1	1	1	1	GD05823140	82K Ω
R218	1	1	1	1	GD05334140	330K Ω
R219	1	1	1	1	GD05472140	4.7K Ω
R220	1	1	1	1	GD05102140	1K Ω
R222	1	1	1	1	GD05821140	820 Ω
R223	1	1	1	1	GD05102140	1K Ω
R224	1	1	1	1	GD05102140	1K Ω
R225	1	1	1	1	GD05152140	1.5K Ω
R226	1	1	1	1	GD05101140	100 Ω
R227	1	1	1	1	GD05101140	100 Ω
R228	1	1	1	1	GD05820140	82 Ω
R229	1	1	1	1	GD05560140	56 Ω
R230	1	1	1	1	GD05471140	470 Ω
R231	1	1	1	1	GD05331140	330 Ω
R232	1	1	1	1	GD05102140	1K Ω
R233	1	1	1	1	GD05181140	180 Ω
R234	1	1	1	1	GD05331140	330 Ω
R235	1	1	1	1	GD05391140	390 Ω
R236	1	1	1	1	GD05221140	220 Ω
R237	1	1	1	1	GD05102140	1K Ω
R238	1	1	1	1	GD05102140	1K Ω
R239	1	1	1	1	GD05222140	2.2K Ω
R240	1	1	1	1	GD05102140	1K Ω
R241	1	1	1	1	GD05223140	22K Ω
R242	1	1	1	1	GD05332140	3.3K Ω
R251	1	1	1	1	GD05224140	220K Ω
R252	1	1	1	1	GD05101140	100 Ω
R253	1	1	1	1	GD05104140	100K Ω
R254	1	1	1	1	GD05823140	82K Ω
R255	1	1	1	1	GD05103140	10K Ω
R256	1	1	1	1	GD05271140	270 Ω
R257	1	1	1	1	GD05561140	560 Ω
R258	1	1	1	1	GD05334140	330K Ω
R259	1	1	1	1	GD05682140	6.8K Ω
R260	1	1	1	1	RA05020160	5K Ω Trimming
R261	1	1	1	1	GD05562140	5.6K Ω
R262	1	1	1	1	GD05102140	1K Ω
R263	1	1	1	1	GD05822140	8.2K Ω
R264	1	1	1	1	GD05102140	1K Ω
R265	1	1	1	1	GD05222140	2.2K Ω
R266	1	1	1	1	RA05030090	50K Ω Trimming
R267	1	1	1	1	GG05152140	1.5K Ω
R268	1	1	1	1	GD05102140	1K Ω
R269	1	1	1	1	GD05272140	2.7K Ω
R270	1	1	1	1	GD05333140	33K Ω
△R271	1	1	1	1	GG05331140	330 Ω

- (U): for U.S.A.
- (C): for Canada
- (N): for Europe
- (A): for Australia

REF. DESIG.	Q'TY				PART NO.	DESCRIPTION
	U	C	N	A		
R272	1	1	1	1	GD05334140	330K Ω
R273	1	1	1	1	GD05822140	8.2K Ω
R274	1	1	1	1	GA05821010	820 Ω 1W Ω
R275	1	1	1	1	GD05121140	120 Ω
R276	1	1	1	1	GD05102140	1K Ω
R301	1	1	1	1	GD05393140	39K Ω
R303	1	1	1	1	GD05103140	10K Ω
R304	1	1	1	1	GD05222140	2.2K Ω
R305	1	1	1	1	RA02020180	2K Ω imming
R306	1	1	1	1	RA02020180	2K Ω Trimming
R307	1	1	1	1	RA02020180	2K Ω imming
R308	1	1	1	1	GD05331140	330 Ω Trimming
R309	1	1	1	1	GD05122140	1.2K Ω
R310	1	1	1	1	RA01020110	1K Ω Trimming
R311	1	1	1	1	GD05822140	8.2K Ω
R312	1	1	1	1	GD05822140	8.2K Ω
R313	1	1	1	1	GD05822140	8.2K Ω
R314	1	1	1	1	GD05101140	100 Ω
R315	1	1	1	1	GD05332140	3.3K Ω
R316	1	1	1	1	GD05101140	100 Ω
R317	1	1	1	1	GD05332140	3.3K Ω
R318	1	1	1	1	GD05822140	8.2K Ω
R319	1	1	1	1	GD05822140	8.2K Ω
P100-SEMICONDUCTORS						
Q101	1	1	1	1	HT326341S0	Transistor 2SC2634(S)
Q102	1	1	1	1	HT326341S0	Transistor 2SC2634(S)
Q103	1	1	1	1	HT326341S0	Transistor 2SC2634(S)
Q104	1	1	1	1	HT326341S0	Transistor 2SC2634(S)
Q105	1	1	1	1	HT326341S0	Transistor 2SC2634(S)
Q106	1	1	1	1	HT326341S0	Transistor 2SC2634(S)
Q107	1	1	1	1	HT326341S0	Transistor 2SC2634(S)
Q151	1	1	1	1	HT326341T0	Transistor 2SC2634(T)
Q152	1	1	1	1	HT326341T0	Transistor 2SC2634(T)
Q153	1	1	1	1	HT326341S0	Transistor 2SC2634(S)
Q154	1	1	1	1	HT326341S0	Transistor 2SC2634(S)
Q155	1	1	1	1	HT326341S0	Transistor 2SC2634(S)
Q156	1	1	1	1	HT326341S0	Transistor 2SC2634(S)
Q157	1	1	1	1	HT326341T0	Transistor 2SC2634(T)
Q201	1	1	1	1	HT326341S0	Transistor 2SC2634(S)
Q202	1	1	1	1	HT326341S0	Transistor 2SC2634(S)
Q203	1	1	1	1	HT326341S0	Transistor 2SC2634(S)
Q204	1	1	1	1	HT326341S0	Transistor 2SC2634(S)
Q205	1	1	1	1	HT326341S0	Transistor 2SC2634(S)
Q206	1	1	1	1	HT326341S0	Transistor 2SC2634(S)
Q207	1	1	1	1	HT326341S0	Transistor 2SC2634(S)
Q251	1	1	1	1	HT326341T0	Transistor 2SC2634(T)
Q252	1	1	1	1	HT326341T0	Transistor 2SC2634(T)
Q253	1	1	1	1	HT326341S0	Transistor 2SC2634(S)
Q254	1	1	1	1	HT326341S0	Transistor 2SC2634(S)
Q255	1	1	1	1	HT326341S0	Transistor 2SC2634(S)
Q256	1	1	1	1	HT326341S0	Transistor 2SC2634(S)
Q257	1	1	1	1	HT326341T0	Transistor 2SC2634(T)
Q301	1	1	1	1	HD20011050	Diode 1S1555
△ Q302	1	1	1	1	HT315681R0	Transistor 2SC1568(R)
Q111	1	1	1	1	HD30024090	Diode WZ-120
Q211	1	1	1	1	HD30024090	Diode WZ-120
Q161	1	1	1	1	HD30024090	Diode WZ-120
Q261	1	1	1	1	HD30024090	Diode WZ-120

REF. DESIG.	Q'TY				PART NO.	DESCRIPTION
	U	C	N	A		
J101	41	41	41	41	YP10001130	P100-MISCELLANEOUS Plug, Wire Wrap
J301	1	1	1	1	YT02040230	Terminal, RCA
J301			1	1	BY01050110	Jack, RCA/Din
L101	1	1	1	1	LS70305010	M.P.X. Coil 19KHz
L102	1	1	1	1	LC24750030	Choke Coil 4.7mH Rec. EQ.
L103	1	1	1	1	LC24750030	Choke Coil 4.7mH Rec. EQ.
L151	1	1	1	1	LC22260060	Choke Coil 22mH Bias Trap
L201	1	1	1	1	LS70305010	M.P.X. Coil 19KHz
L202	1	1	1	1	LC24750030	Choke Coil 4.7mH Rec. EQ.
L203	1	1	1	1	LC24750030	Choke Coil 4.7mH Rec. EQ.
L251	1	1	1	1	LC22260060	Choke Coil 22mH Bias Trap
L301	1	1	1	1	LC21050010	Choke Coil 1mH
S007	1	1	1	1	SC00020020	Switch, Flexible Wire
S301	1	1	1	1	SS12020100	Slide Switch, Speed
S302	1	1	1	1	SP10060010	Push Switch, Normal
S303	1	1	1	1	SP10060010	Push Switch, CrO ₂ /Special
S304	1	1	1	1	SP10060010	Push Switch, FE/CR
S305	1	1	1	1	SP10060010	Push Switch, Metal
S306	1	1	1	1	SP10060010	Push Switch, Dolby
S307	1	1	1	1	SP10060010	Push Switch, MPX Filter
P400-FUSE CIRCUIT BOARD						
P400		1	1		YK42771220	P.W. Board, Fuse
		1	1		ZZ42778220	P.W. Board Assembly
J401			6	6	YP10001130	Plug, Wire Wrap
J406						
J407						
J412			6	6	YJ08000200	Jack, Fuse Clip
△ F401			1	1	FS10050800	Fuse 0.5A
△ F402			1	1	FS10063800	Fuse 630A
△ F403			1	1	FS10063800	Fuse 630A
P450-SKIP CIRCUIT BOARD						
P450	1	1	1	1	YF42760020	P.W. Board, Skip
	1	1	1	1	ZZ42760020	P.W. Board Assembly
P450-CAPACITORS						
C451	1	1	1	1	DF15472300	Film 4700pF ±5%
C452	1	1	1	1	DK16221300	Ceramic 220pF ±10%
C453	1	1	1	1	EA47505030	Elect 4.7 μ F 50V
C454	1	1	1	1	EA10505030	Elect 1 μ F 50V
C455	1	1	1	1	EA10602530	Elect 10 μ F 25V
C456	1	1	1	1	DK16471300	Ceramic 470pF ±10%
C461	1	1	1	1	DF15472300	Film 4700pF ±5%
C462	1	1	1	1	DK16221300	Ceramic 220pF ±10%
C463	1	1	1	1	EA47505030	Elect 4.7 μ F 50V
C464	1	1	1	1	EA10505030	Elect 1 μ F 50V
C465	1	1	1	1	EA10602530	Elect 10 μ F 25V
C466	1	1	1	1	DK16471300	Ceramic 470pF ±10%
C481	1	1	1	1	EA47601030	Elect 47 μ F 10V
C482	1	1	1	1	EA22602530	Elect 22 μ F 25V
△ C483	1	1	1	1	EA10702530	Elect 100 μ F 25V
C484	1	1	1	1	EA33505030	Elect 3.3 μ F 50V

10. TECHNICAL SPECIFICATIONS

[FOR U.S.A. & CANADA]

Type	Front loading 4-Track, 2-Channel Stereo Record/Playback System	
Tape	Phillips-type Compact Cassette	
Tape Speeds	High: 3-3/4 ips (9.52 cm/sec) Standard: 1-7/8 ips (4.75 cm/sec)	
Motor Drive System	DC Servo Motor (x1) with Single Capstan Drive	
Heads	.3 Head System Erase Head: Permalloy Record Head/Play Head: Sendust Alloy	
Level Indicators	Left and Right Peak Level Displays	
Noise Reduction System	Dolby NR	
Semiconductors		
Transistors	59	
IC's	6	
Diodes	34	
LED's	6	
	High Speed (3-3/4 I.P.S.)	Standard Speed (1-7/8 I.P.S.)
Wow and Flutter (WRMS)	0.04%	0.06%
Frequency Response		
(Overall, -20 dB below 0 VU)		
Metal	30 Hz ~ 22 kHz (±3 dB)	30 Hz ~ 19 kHz (±3 dB)
Ferrichrome (FeCr)	30 Hz ~ 20 kHz (±3 dB)	30 Hz ~ 17 kHz (±3 dB)
Chromium Dioxide (CrO ₂)	30 Hz ~ 20 kHz (±3 dB)	30 Hz ~ 17 kHz (±3 dB)
Ferric (Normal)	30 Hz ~ 18 kHz (±3 dB)	30 Hz ~ 15 kHz (±3 dB)
Signal-to-Noise Ratio		
Dolby ON	70 dB	67 dB
Dolby OFF	60 dB	57 dB
Outputs		
Line: Level	650 mV	
Impedance	2.5 kΩ	
Headphone: Level	43 mV	
Impedance	100 Ω	
Inputs (Level at 0 VU)		
Line: Sensitivity	-23 dBV (70 mV)	
Impedance	82 kΩ	
Mic: Sensitivity	-72 dBV (0.25 mV)	
Impedance	Low Z	
Fast Rewind Time	Approx. 100 sec. (C-60 cass.)	
Fast Forward Time	Approx. 100 sec. (C-60 cass.)	
Bias Frequency	100 kHz	
Power Requirements	120 V AC, 60 Hz	
Power Consumption	18 Watts	
Dimensions (W x H x D)	16-3/8 in. x 5-3/4 in. x 9-9/16 in. (41.6 cm) x (14.6 cm) x (24.3 cm)	
Net Weight	15.7 lbs. (7 kg)	

NOTES:

1. Reference recording level: 0 VU (16 nW/M)
2. Reference frequency: 315 Hz
3. Wow and flutter measured at: 3.0 kHz NAB WGTD RMS
4. Frequency response measured at: 20 dB below 0 VU recording level reference (Dolby off)
5. S/N ratio measured at the recorded level equivalent to 3% THD, IEC "A" WGTD, 70 μSec. EQ.
6. Recording reference tapes:
 - Standard: TDK AC211
 - CrO₂: TDK AC511
 - FeCr: Sony CS30
 - Metal: TDK. AC701 Metafine

[FOR EUROPE]

Style	Front load	
Tape Drive System	Single Capstan Drive	
Cartridge	Philips type compact cassette	
Track System	Compatible Stereo 4-track 2-channel	
Tape Speed	4.75 cm/sec & 9.52 cm/sec	
Heads	3 Head System	
Composition	Rec/Play: Sendust Alloy Erase: Permalloy	
Motor	DC Servo Controlled Motor x 1	
Meters	LED peak x 2	
Recording System	AC Bias	
Erasing System	AC Erase	
Semiconductor Complement		
Transistors	59	
Diodes	34	
IC's	6	
LED's	6	
Overall Frequency Response (Dolby off):		
	High Speed (9.52 cm/sec)	Standard Speed (4.75 cm/sec)
Ferric Oxide Tape	35 Hz ~ 17 kHz (±3 dB)	40 Hz ~ 13.5 kHz (±3 dB)
CrO ₂ Tape	35 Hz ~ 17.5 kHz (±3 dB)	40 Hz ~ 14 kHz (±3 dB)
FeCr Tape	35 Hz ~ 18 kHz (±3 dB)	40 Hz ~ 14.5 kHz (±3 dB)
Metal Tape	35 Hz ~ 19 kHz (±3 dB)	40 Hz ~ 15 kHz (±3 dB)
Total Harmonic Distortion		
Ferric Oxide Tape2%	
CrO ₂ Tape	2.5%	
FeCr Tape	2.5%	
Metal Tape	2.5%	
	High Speed (9.52 cm/sec)	Standard Speed (4.75 cm/sec)
Wow and Flutter (DIN WTD)	0.10%	0.15%
Fast Rewind Time	110 sec.	
Fast Forward Time	110 sec.	
AC Line Voltage	220 V AC, 50 Hz (E/N versions are featuring an external voltage selector for use on 110/220 V. T/A versions 220/240 V AC, 50/60 Hz.)	
Power consumption	21 Watts	
Dimensions (W x H x D)	416 mm x 146 mm x 243 mm	
Weight	5.5 kg	

*These specifications and exterior design may be changed for improvement without notice.



SERVICE
MANUAL

SD4020

Since only the unidentical parts between the original model are listed, please use this manual (Flysheet) with the original model SD4000 (N version) service manual accordingly.

Different Parts between MODEL SD4000 (N) and MODEL SD4020 (N)

REF. DESIG.	Q'TY	SD4000 (N) PART NO.	DESCRIPTION	REF. DESIG.	Q'TY	SD4020 (N) PART NO.	DESCRIPTION
A1	1	4277063410	Front Panel Assembly	A1	1	4277063430	Front Panel Assembly
060B	1	2128118010	Spacer	060B	2	4279118050	Spacer
930B	1	4277063020	Escutcheon	930B	1	4277063060	Escutcheon
B	1	4276302410	Dial Assembly	B	1	4276302420	Dial Assembly
972B	1	4276302020	Dial	972B	1	4276302040	Dial
021B	2	4277154010	Knob	021B	2	4277154030	Knob
022B	2	4277154020	Knob	022B	2	4277154040	Knob
042B	1	3448067060	Cap	042B	1	3448067200	Cap
051B	1	4214257010	Lid	051B	1	108T257010	Lid
052B	4	51480406S9	F. Washer Screw	052B	4	51480406B9	F. Washer Screw
053B	3	51280308U0	B.H. Tapped Screw	053B	3	51280308K0	B.H. Tapped Screw
906B	1	4277265030	Indicator	906B	1	4277265100	Indicator
956B	1	4276063030	Escutcheon	956B	1	4276063230	Escutcheon
957B	1	4276063040	Escutcheon	957B	1	4276063240	Escutcheon
967B	1	3448154060	Knob	967B	1	3448154240	Knob
976B	1	3448154060	Knob	976B	1	3448154240	Knob
977B	1	2970154020	Knob	977B	1	2970154220	Knob
084F	1	4265053030	Cover	084F	1	4265053130	Cover
001T	1	4276851310	Instruction	001T	1	4277851350	Instruction
002T	1	4277851030	Spec Flysheet	002T	1	4277851330	Spec Flysheet
901U	1	4277801030	Packing Case	901U	1	4277801080	Packing Case

N.B. Following precautions should be used when putting order for service manual:

- (1) The original Service manual will not be delivered if the P/N 4277855040 (Flysheet) is used for ordering.
- (2) When comprehensive manual are required, please use both P/N of 4277855010 (Original) and 4277855040 (Flysheet) simultaneously.

marantz®

SCHEMATIC DIAGRAM

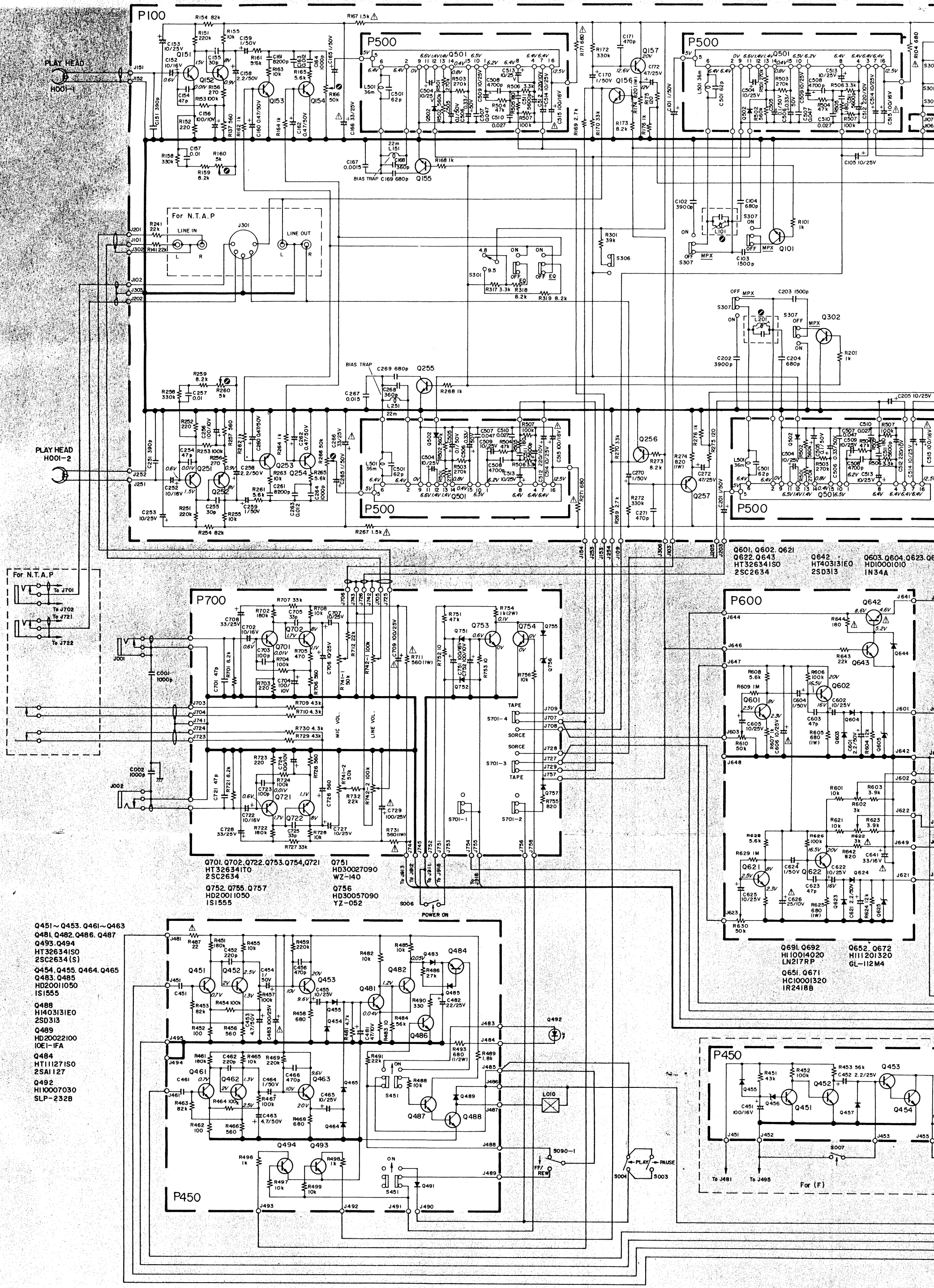

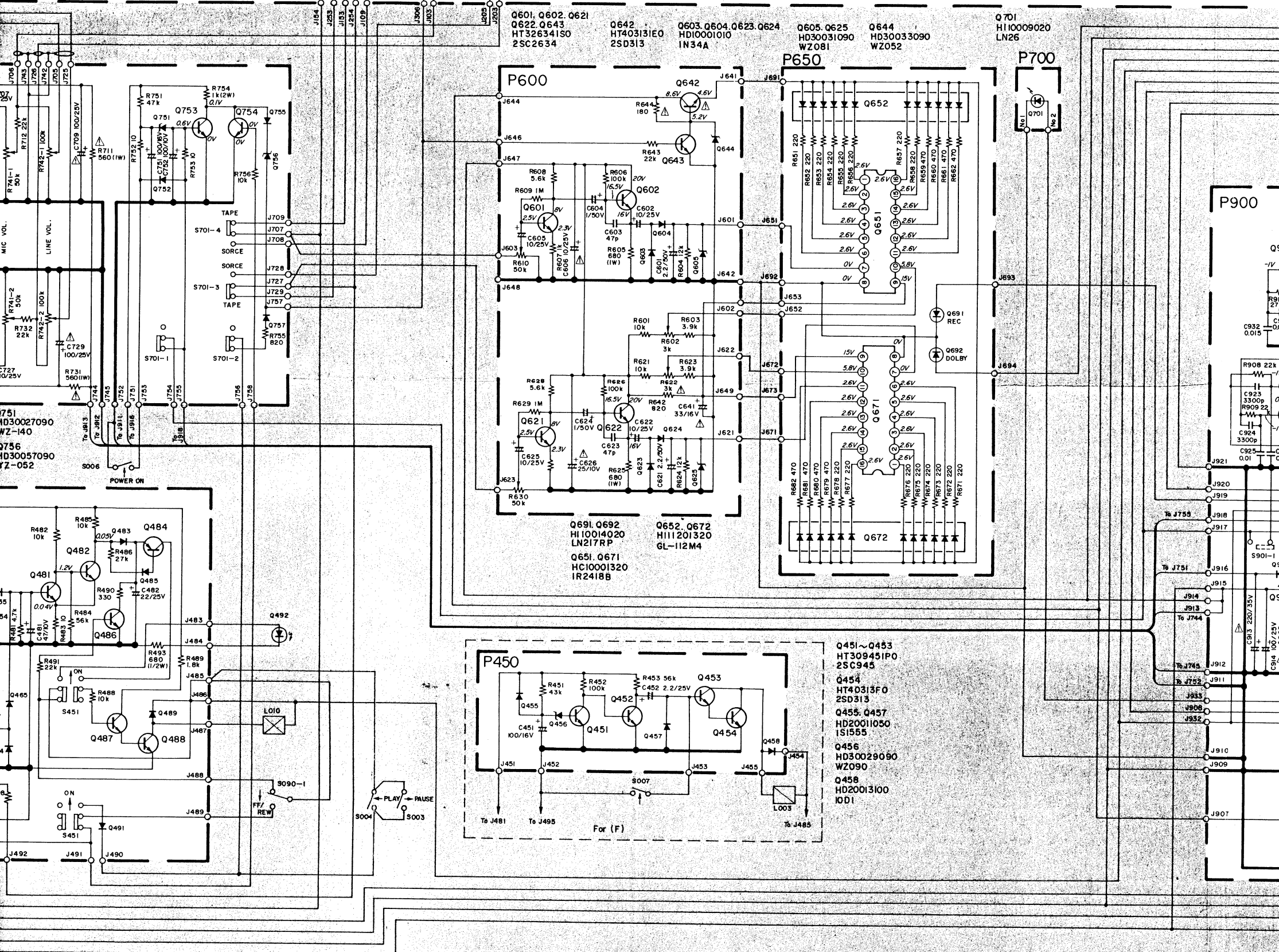
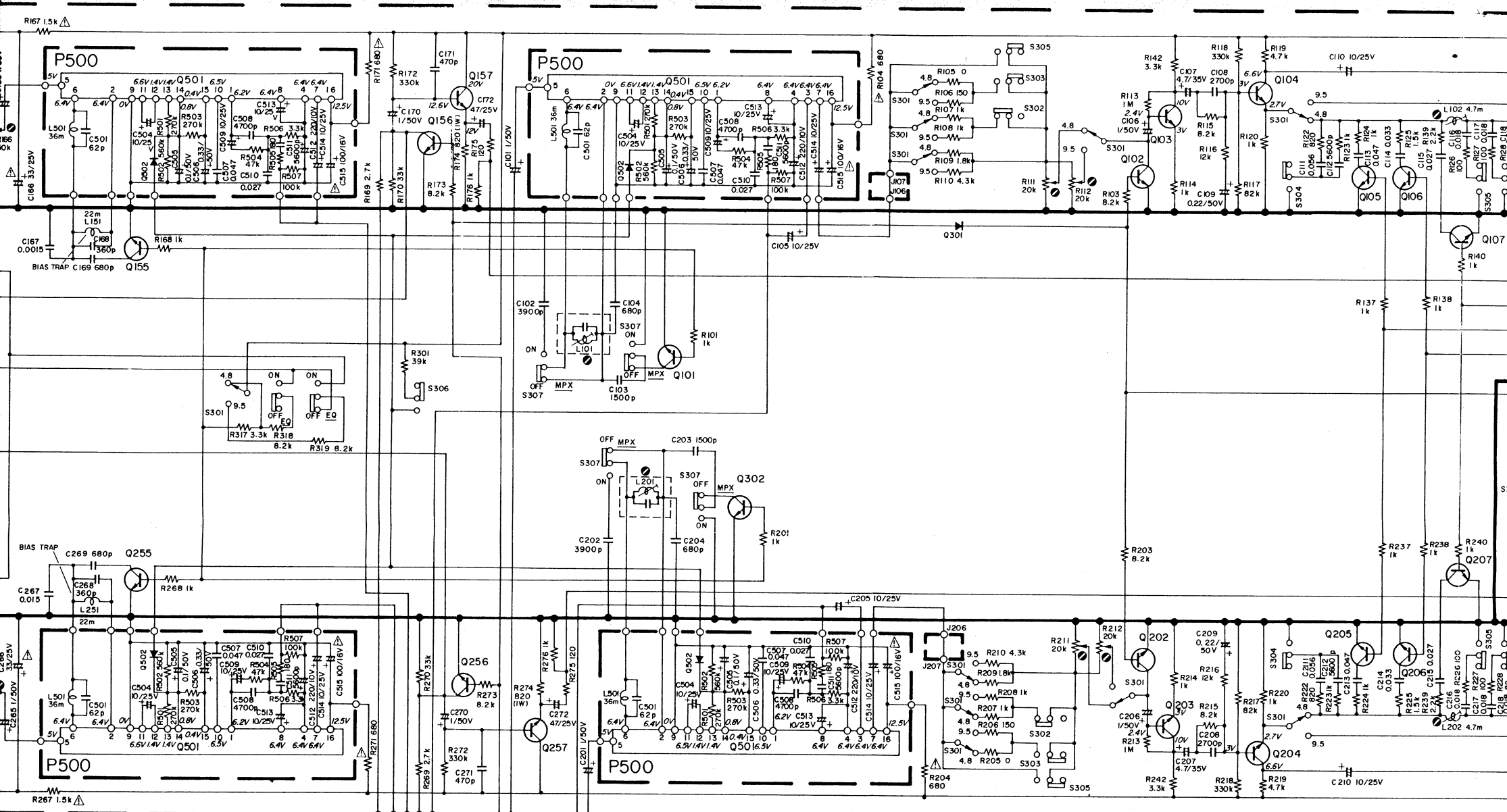

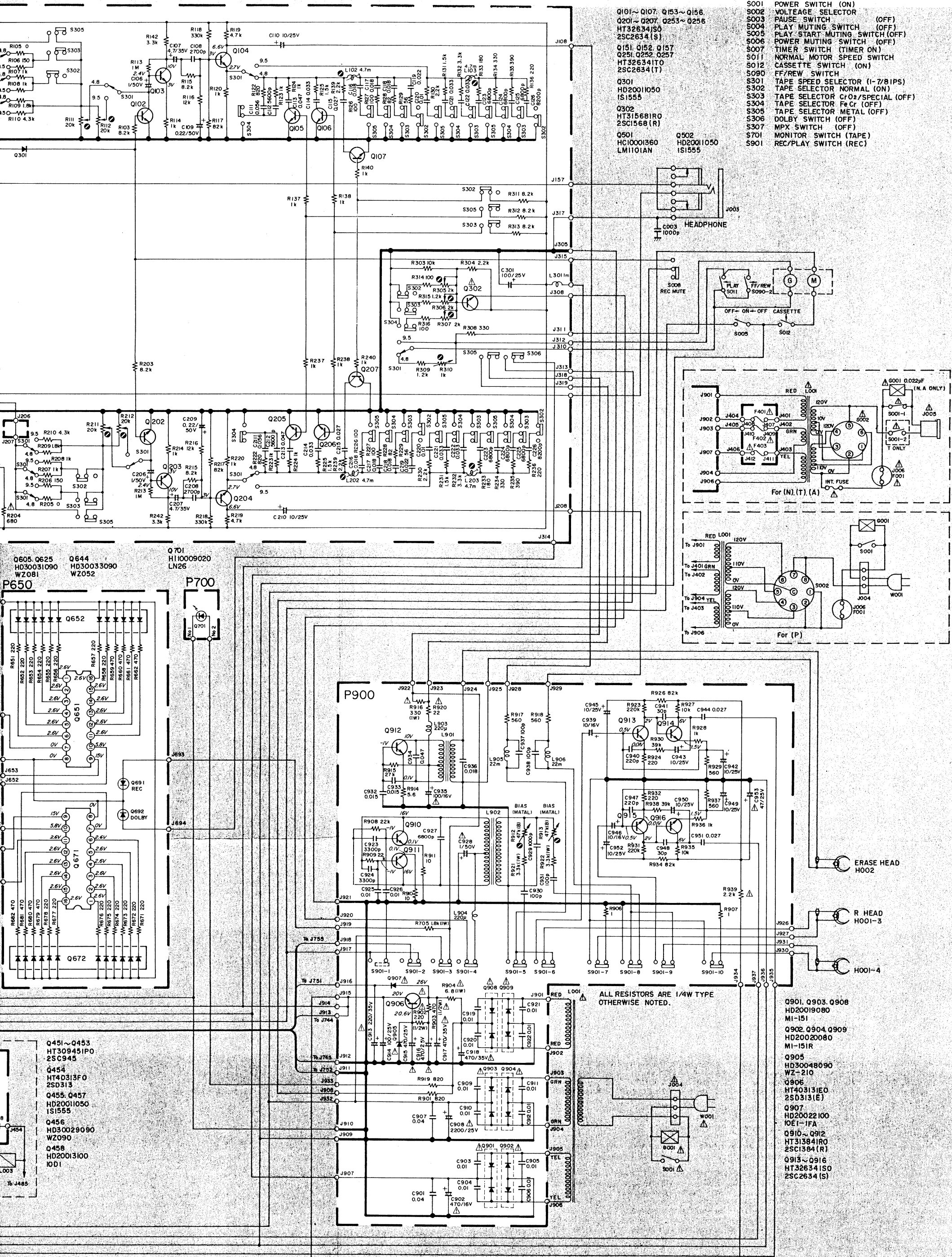

- SWITCHES
- S001 POWER SWITCH (ON)
 - S002 VOLTEAGE SELECTOR
 - S003 PAUSE SWITCH (OFF)
 - S004 PLAY MUTING SWITCH (OFF)
 - S005 PLAY-START MUTING SWITCH (OFF)
 - S006 POWER MUTING SWITCH (OFF)
 - S007 TIMER SWITCH (TIMER ON)
 - S011 NORMAL MOTOR SPEED SWITCH
 - S012 CASSETTE SWITCH (ON)
 - S090 FF/REW SWITCH
 - S301 TAPE SPEED SELECTOR (1-7/8IPS)
 - S302 TAPE SELECTOR NORMAL (ON)
 - S303 TAPE SELECTOR C/O2/SPECIAL (OFF)
 - S304 TAPE SELECTOR Fe Cr (OFF)
 - S305 TAPE SELECTOR METAL (OFF)
 - S306 DOLBY SWITCH (OFF)
 - S307 MPX SWITCH (OFF)
 - S701 MONITOR SWITCH (TAPE)
 - S901 REC/PLAY SWITCH (REC)

- Q101~Q107: Q153~Q156
- Q201~Q207, Q253~Q256
- HT32634(S)
- 2SC2634 (S)
- Q151, Q152, Q157
- Q251, Q252, Q257
- HT32634(IT)
- 2SC2634(T)
- Q301
- HD20011050
- IS1555
- Q302
- HT315681(R)
- 2SC1568 (R)
- Q501
- HC10001360
- LM1101AN
- Q502
- HD20011050
- IS1555

- Q605, Q625
- HD30031090
- WZ081
- Q644
- HD30033090
- WZ052
- Q701
- HI10009020
- LN26

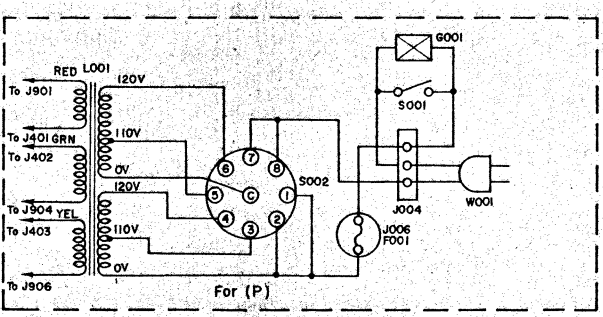
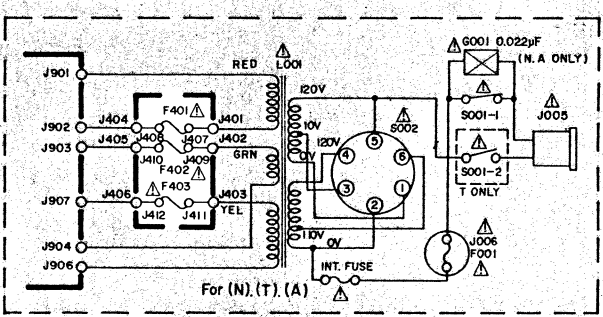
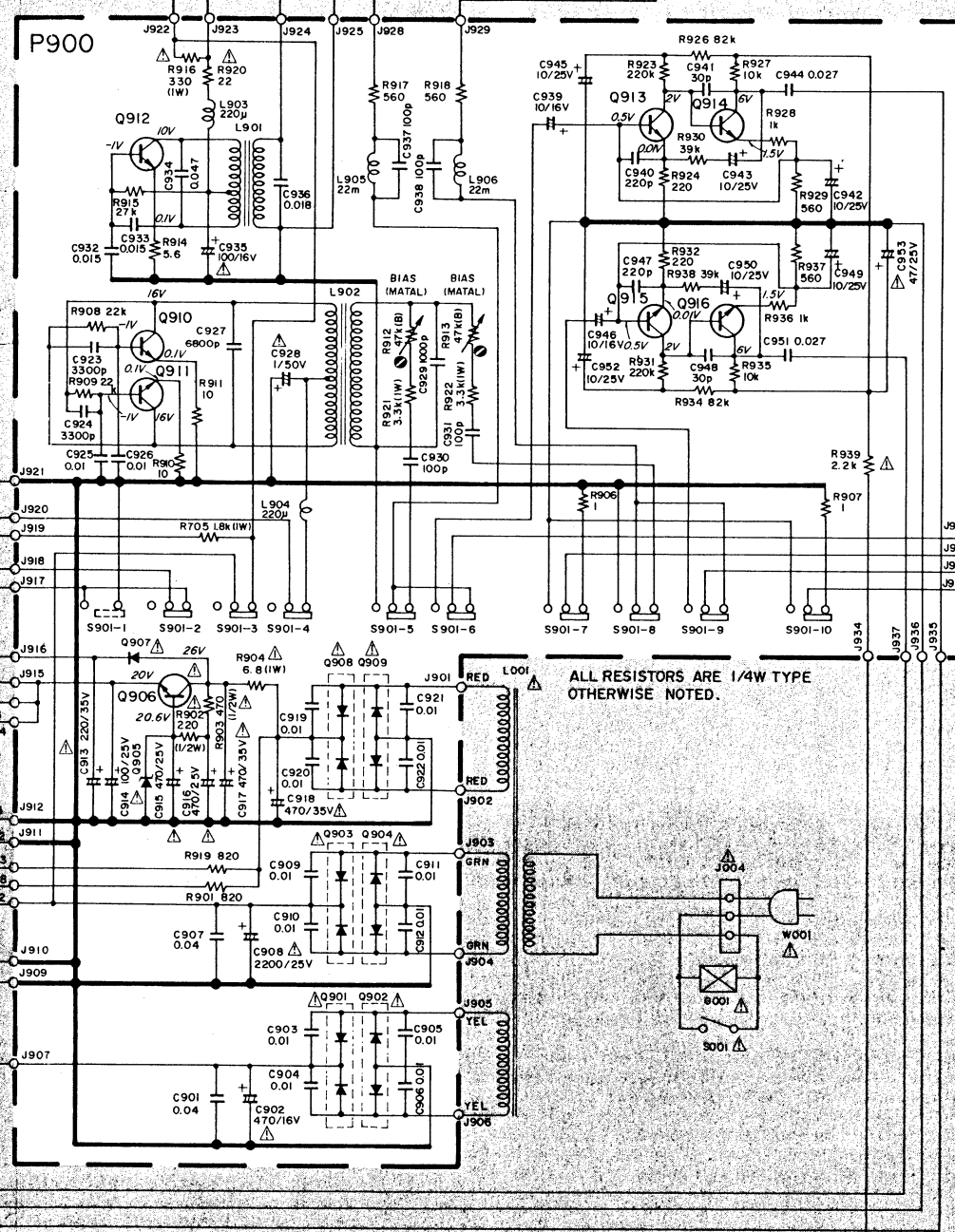
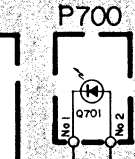
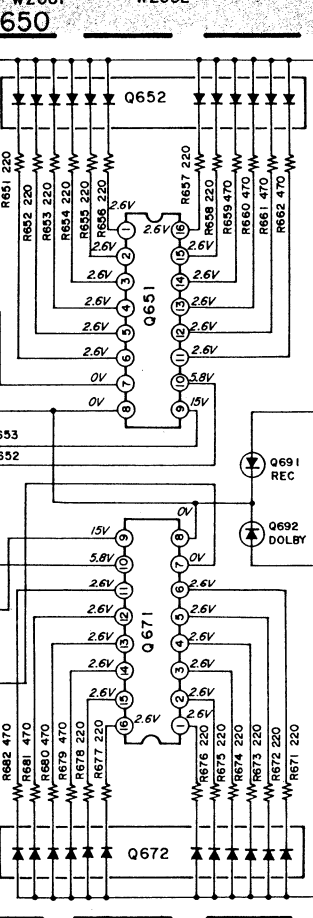

- Q901, Q903, Q908
- HD20019080
- MI-151
- Q902, Q904, Q909
- HD20020080
- MI-151R
- Q905
- HD30048090
- WZ-210
- Q906
- HT40313(E)
- 2SD313(E)
- Q907
- HD20022100
- IOE1-1FA
- Q910~Q912
- HT31384(R)
- 2SC1584 (R)
- Q913~Q916
- HT32634(S)
- 2SC2634 (S)

NOTE ON SAFETY: THE PARTS MARKED WITH Δ ARE IMPORTANT PARTS ON THE SAFETY. PLEASE USE THE PARTS HAVING THE DESIGNATED PARTS NUMBER WITHOUT FAIL.

273



marantz®

MARANTZ CO., INC. · P.O. BOX 577 · CHATSWORTH, CALIFORNIA · 91311



A WHOLLY-OWNED SUBSIDIARY OF SUPERSCOPE INC., CHATSWORTH, CALIFORNIA · 91311

Noise Reduction System manufactured under license from Dolby Laboratories.
"DOLBY", the Double-D symbol and the word "Dolbyized" are trademarks of Dolby Laboratories.

MARANTZ is a registered trademark of Marantz Company, Inc. A subsidiary of Superscope, Inc.