

# Service Manual

75SR1030 /1B /2B

75SR1040 /1A /2A

Stereo receiver



## TABLE OF CONTENTS

SECTION	PAGE
1. TECHNICAL SPECIFICATIONS .....	1
2. BLOCK DIAGRAM .....	2
3. SCHEMATIC DIAGRAM AND PARTS LOCATION ( Pattern side ) .....	4
4. EXPLODED VIEW AND PARTS LIST .....	23
5. IDLING CURRENT ADJUSTMENT .....	25
6. SERVICE PROGRAM .....	25
7. TUNER ALIGNMENT PROCEDURES .....	26
8. ALIGNMENT AND TEST POINT .....	28
9. MICROPROCESSOR SPECIFICATIONS .....	29
10. ELECTRICAL PARTS LIST .....	33

4822 725 51073

# marantz®

## model SR1030 / SR1040

First issue : 1994 / 9

PCS 79 597

**MARANTZ DESIGN AND SERVICE**

Using superior design and selected high grade components, MARANTZ company has created the ultimate in stereo sound. Only **original MARANTZ parts** can insure that your MARANTZ product will continue to perform to the specifications for which it is famous.

Parts for your MARANTZ equipment are generally available at our National Marantz Subsidiary or Agent.

MARANTZ EUROPE B.V.  
P.O. Box 80002  
Building SFF 2  
5600 JB Eindhoven  
The Netherlands  
Phone : +31 -40-732241  
Fax : +31 -40-735578

**ORDERING PARTS**

Parts can be ordered either by mail or by telex. In both cases, the correct part number has to be specified. The following information must be supplied to eliminate delays in processing your order:

1. Complete address
2. Complete part numbers and quantities required
3. Description of parts
4. Model number for which the part is required
5. Way of shipment
6. Signature: any order form or telex must be signed, otherwise such part order will be considered as null and void.

**ADDRESSES**

**AUSTRALIA**  
MARANTZ AUSTRALIA  
Figtree Drive  
Australia Centre  
Homebush, NSW 2140  
AUSTRALIA

**FINLAND**  
MARANTZ  
Kuortaneagatan 1  
00520  
Helsingfors 52  
Finland

**ITALY**  
MARANTZ ITALIANA SPA  
Piazza IV Novembre 3  
20124 Milano  
Italy

**NORWAY**  
MARANTZ  
Postboks 7034  
Assiden  
3007 Drammen  
Norway

**SPAIN**  
MARANTZ SPAIN  
Martinez Villergas 2  
Apartado 2065  
Madrid 28027  
Spain

**AUSTRIA**  
MARANTZ  
Hietzinger Kai 137a  
1130 Wien  
Austria

**FRANCE**  
MARANTZ FRANCE  
4 Rue Bernard Palissy  
92600 Asnières  
France

**JAPAN**  
MARANTZ JAPAN INC.  
35-1, 7-chome, Sagami-cho  
Sagamihara-shi, Kanagawa  
Japan

**PORTUGAL**  
COREL  
Av. da Liberdade  
211-2-Esq.  
1200 Lisboa  
Portugal

**SWEDEN**  
MARANTZ  
Box 1324  
17125 Solna  
Sweden

**BELGIUM**  
MARANTZ EUROPE B.V.  
Div. Benelux  
P.O.Box 80002  
Building SFF 2  
5600 JB Eindhoven  
The Netherlands

**GERMANY**  
MARANTZ GERMANY GmbH  
Kleine Heide 12  
Postfach 4802  
Halle-Westfalen  
Germany

**KUWAIT**  
AL ALAMIAH ELECTRONICS  
P.O.Box 8196  
Salmiah  
22052 Kuwait

**SAUDI ARABIA**  
AL ALAMIAH ELECTRONICS  
P.O.Box 5954  
University Street  
Riyadh 11432  
Saudi Arabia

**SWITZERLAND**  
MARANTZ SWITZERLAND  
Postfach  
8010 Zürich-Müllingen  
Switzerland

**CHILE**  
MARANTZ DIVISION OF  
PHILLIPS S.A.  
Av.Santa Maria 0760  
Casilla 2687  
Santiago  
Chile

**GREAT BRITAIN**  
MARANTZ HIFI UK Ltd.  
Kingsbridge House  
Padbury Oaks  
575-583 Bath Road  
Longford Middlesex UB7 0EH,  
U.K.

**NETHERLANDS**  
MARANTZ EUROPE B.V.  
Div. Benelux  
P.O.Box 80002  
Building SFF 2  
5600 JB Eindhoven  
The Netherlands

**SOUTH AFRICA**  
MARANTZ S.A.  
10 Bond Street  
Randburg 2194  
P.O. Box 7703  
Johannesburg 2000  
South Africa

**TRADING**  
MARANTZ TRADING  
P.O.Box 20008  
Building SFF 2  
5600 JB Eindhoven  
The Netherlands

**DENMARK**  
MARANTZ  
Horsvinget 5  
2630 Tastrup  
Denmark

**GREECE**  
ADAMCO ELECTR. SA  
P.O.Box 21025  
Hippocratus Str. 188  
Athens 11471  
Greece



### 1. TECHNICAL SPECIFICATIONS ( DIN )

**FM TUNER SECTION**  
 Frequency range ..... 87.5 - 108 MHz  
 Sensitivity DIN ( Mono / Stereo ) ..... 1.0 / 25  $\mu$ V  
 S / N ( Mono / Stereo ) ..... 76 / 68 dB  
 T.H.D. .... 0.3 / 0.6%  
 Selectivity at 98 MHz (  $\pm$ 300 kHz ) ..... 60 dB

**MW TUNER SECTION**  
 Frequency range ..... 531 - 1602 kHz  
 Sensitivity DIN ( S / N 20 dB 30% Mod. 999kHz ) ..... 500  $\mu$ V  
 S / N at 999 kHz ..... 50 dB

**LW TUNER SECTION**  
 Frequency range ..... 152 - 282 kHz  
 Sensitivity DIN ( S / N 20 dB 30% Mod. 207 kHz ) ..... 1500  $\mu$ V

**AMPLIFIER SECTION**  
 Power output DIN 8  $\Omega$  ..... 50 W  
 RMS 8  $\Omega$  ..... 45 W  
 IHF Dynamic power 8  $\Omega$  / 4  $\Omega$  / 2  $\Omega$  ..... 64 W / 85 W / 92 W  
 T.H.D. at 8  $\Omega$  rated RMS output ..... 0.05%  
 Damping factor ..... 100  
 Input sensitivity : CD / TAPE / DCC / AUX ..... 220 mV / 40 k $\Omega$   
 S / N ( IFH-A ) : CD / TAPE / DCC / AUX ..... 80 dB

**POWER REQUIREMENTS**  
 / 2A / 2B version ..... 230 V AC, 50 / 60 Hz  
 / 1A / 1B version ..... 115 / 230 V AC, 50 / 60 Hz

**DIMENSIONS**  
 Width ..... 422 mm  
 Height ..... 76 mm  
 Depth ..... 334 mm

**WEIGHT** ..... 5.9 kg ( SR1030 )  
 ..... 6.0 kg ( SR1040 )

**SUPPLIED ACCESSORIES**  
 Remote controller ( RC1040SR ) x 1  
 CR2032 LITHIUM Battery x 1  
 FM antenna x 1  
 AM loop antenna x 1

Specifications subject to change without prior notice.

### 2. BLOCK DIAGRAM

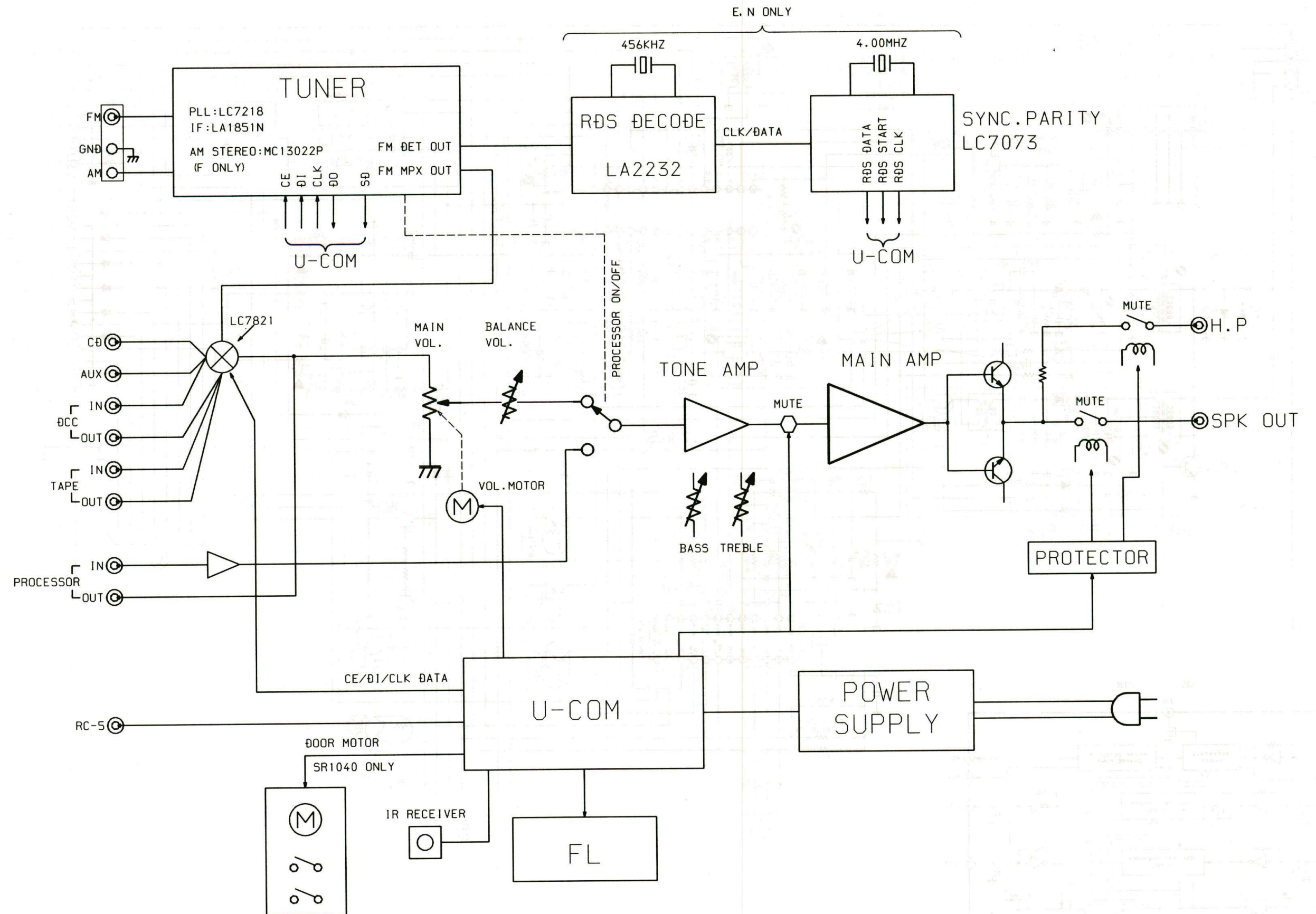







QA03 QA01 QA02 Q202 Q201 Q206 Q204 QV07 QV10~QV12 QV01 QN04 QD01  
 Q502 Q503 Q501 Q303 Q302 Q301 Q305 Q306 QV03~QV06 QV09 Q717 QN05 QN03 QN01 Q801  
 QD02 QA04 QA05 Q203 Q712 Q708 QN02 Q702 Q706 Q704 Q710 Q714 Q707 Q711 Q701 Q703 Q705 Q713 Q709 Q802

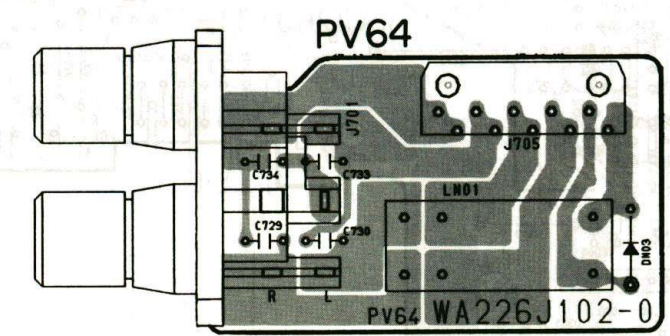
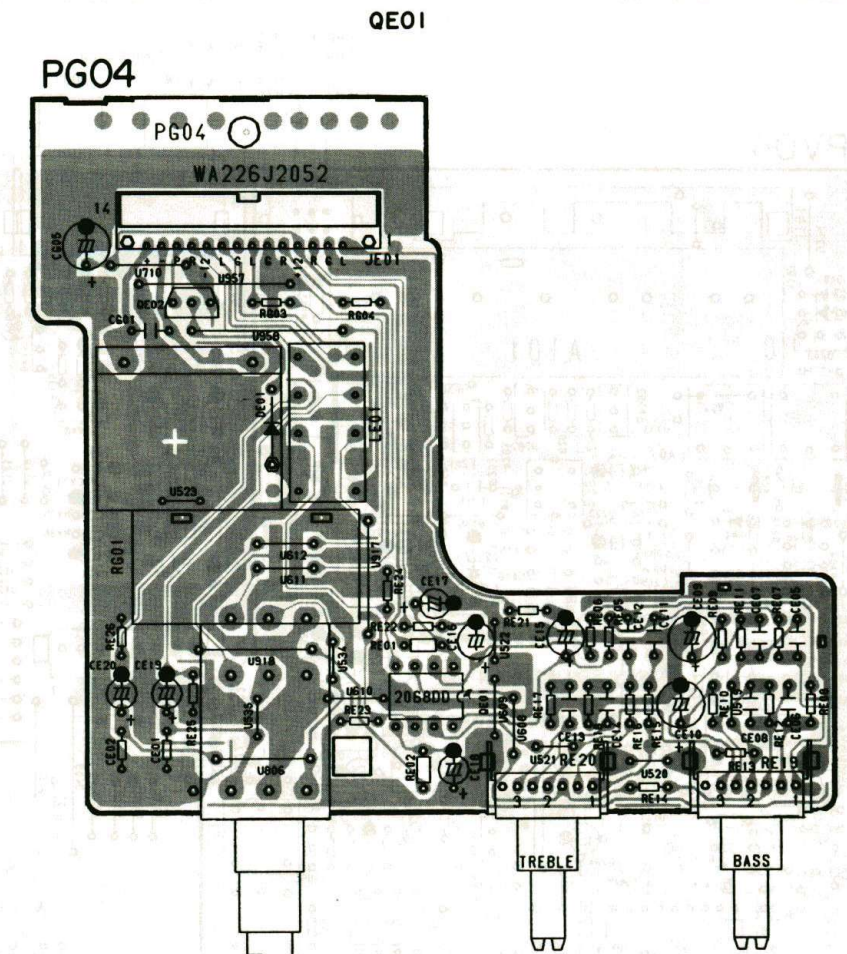
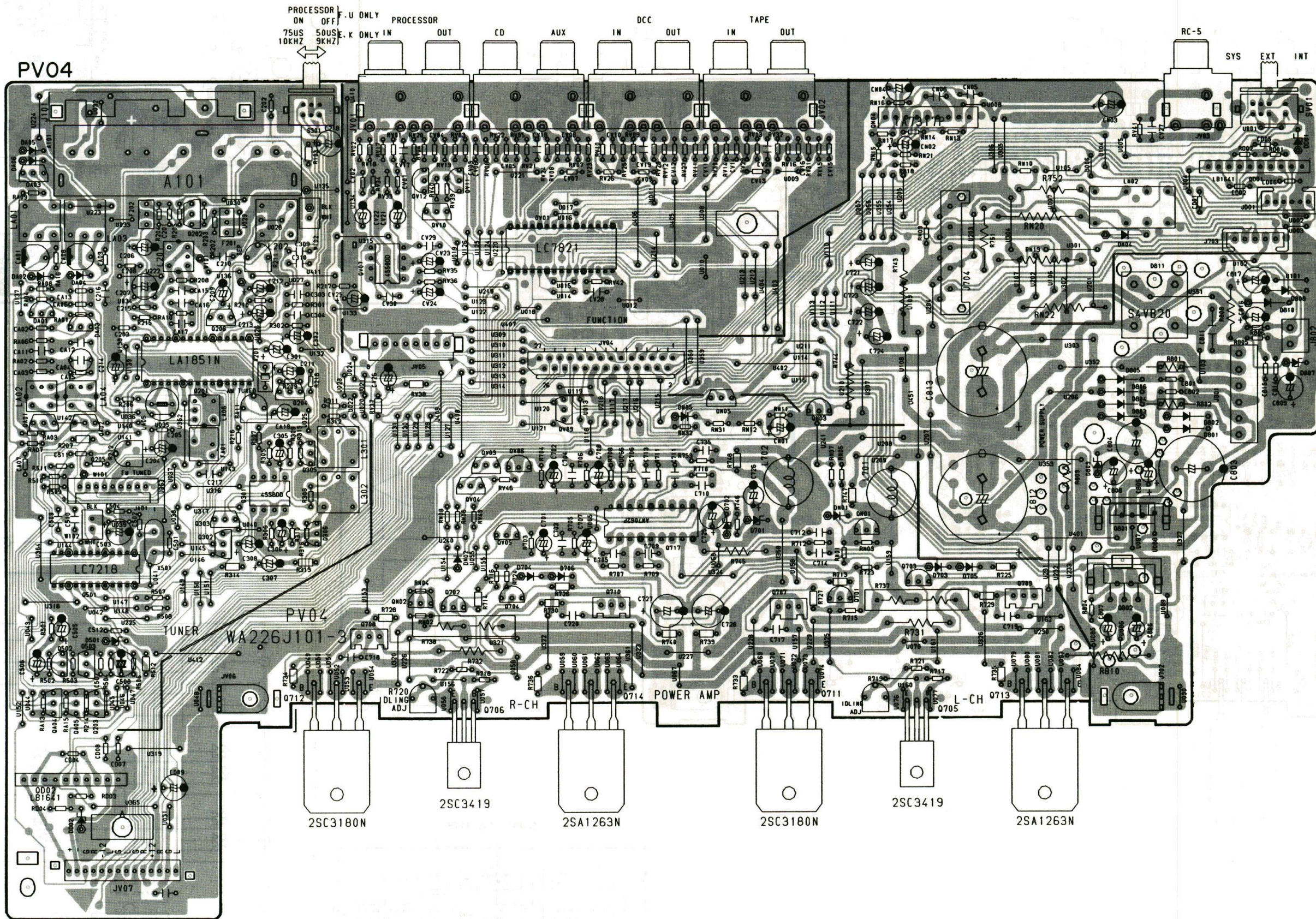



QA03 QA01 QA02 Q202 Q201 Q206 Q204 QV07 QV10~QV12 QV01 QN04 QD01  
 Q502 Q503 Q501 Q303 Q302 Q301 Q305 Q306 QV03~QV06 QV09 QN03 QN01 Q801  
 QD02 QA04 QA05 Q203 Q712 Q708 QN02 Q702 Q706 Q704 Q710 Q714 Q707 Q711 Q701 Q703 Q705 Q713 Q709 Q802

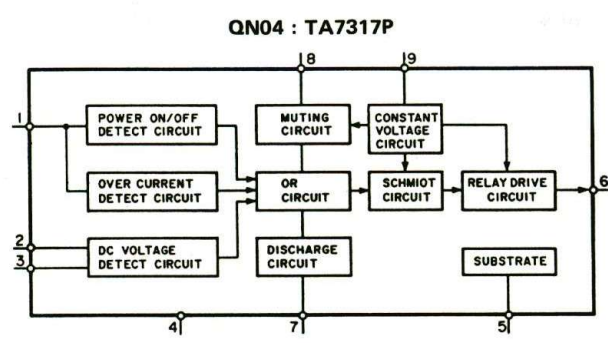
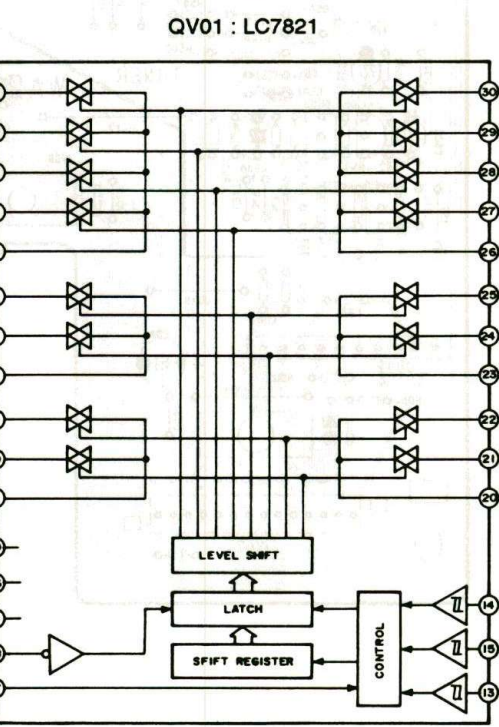
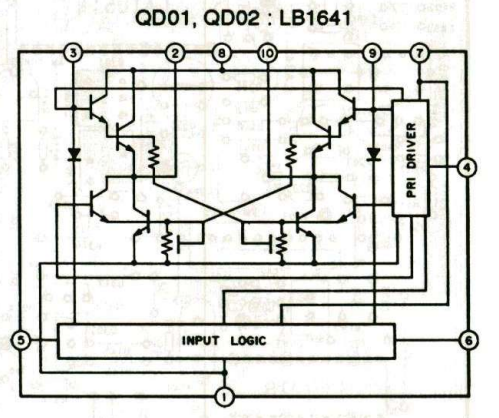
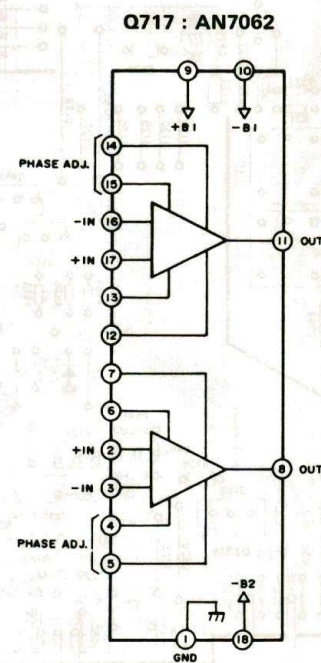
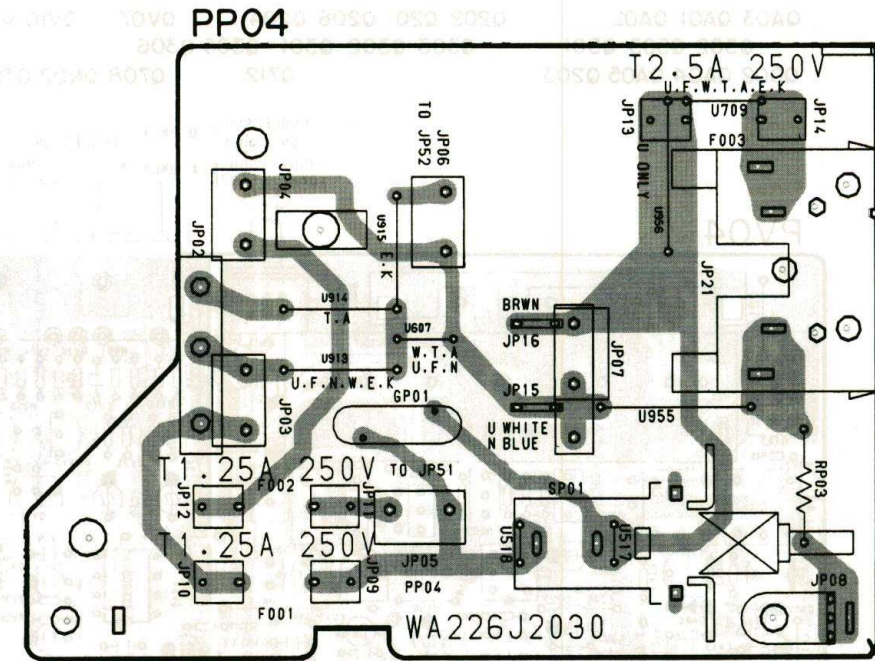
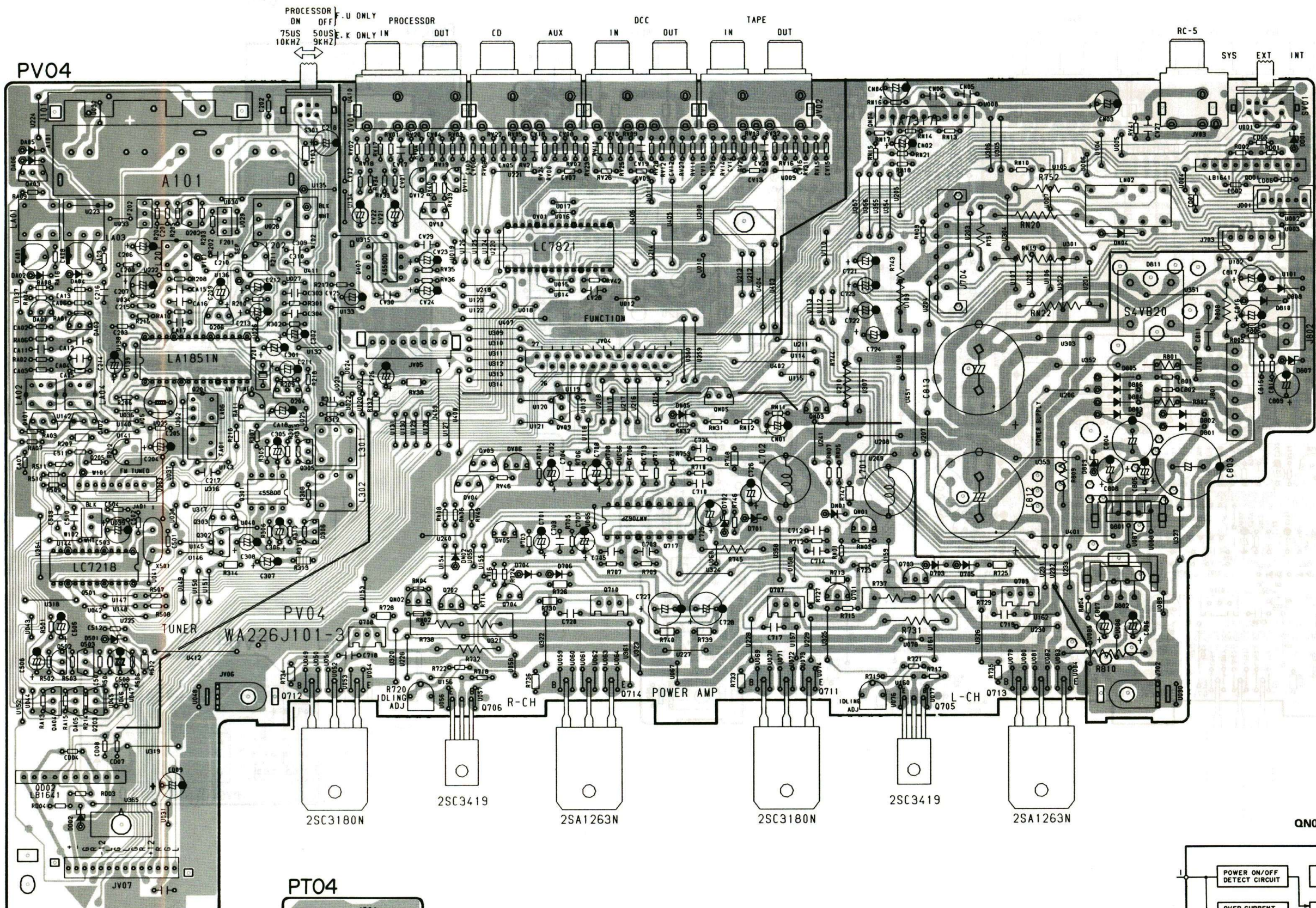



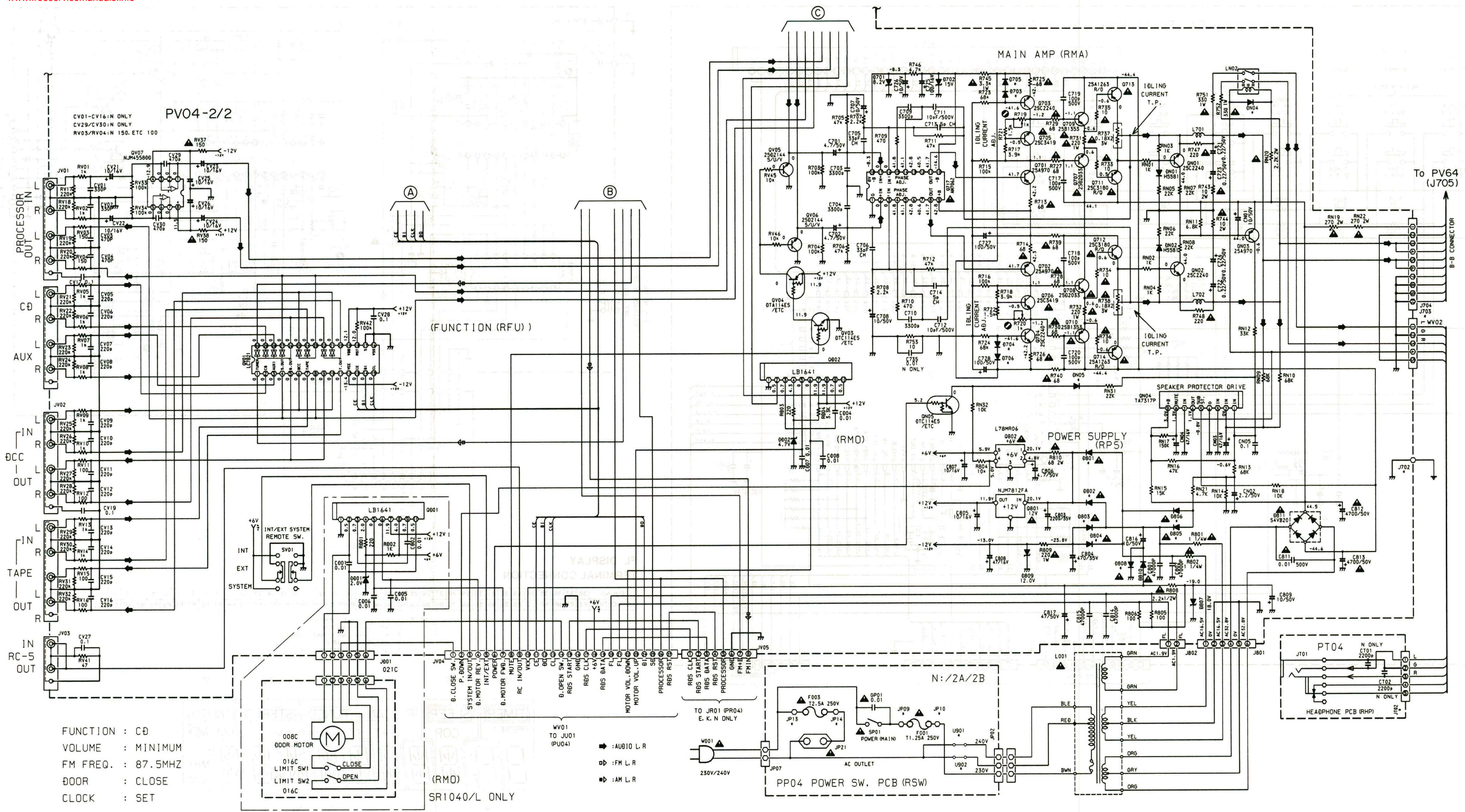

FUNCTION : CD  
 VOLUME : MINIMUM  
 FM FREQ. : 87.5MHZ  
 DOOR : CLOSE  
 CLOCK : SET

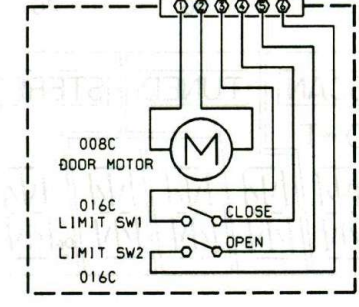

(RMO)  
 SR1040/L ONLY

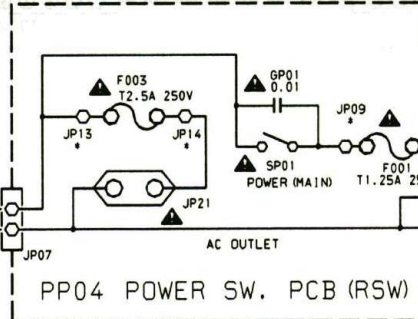

PP04 POWER SW. PCB (RSW)

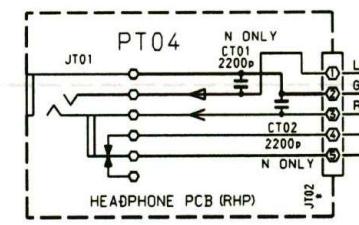

HEADPHONE PCB (RHP)



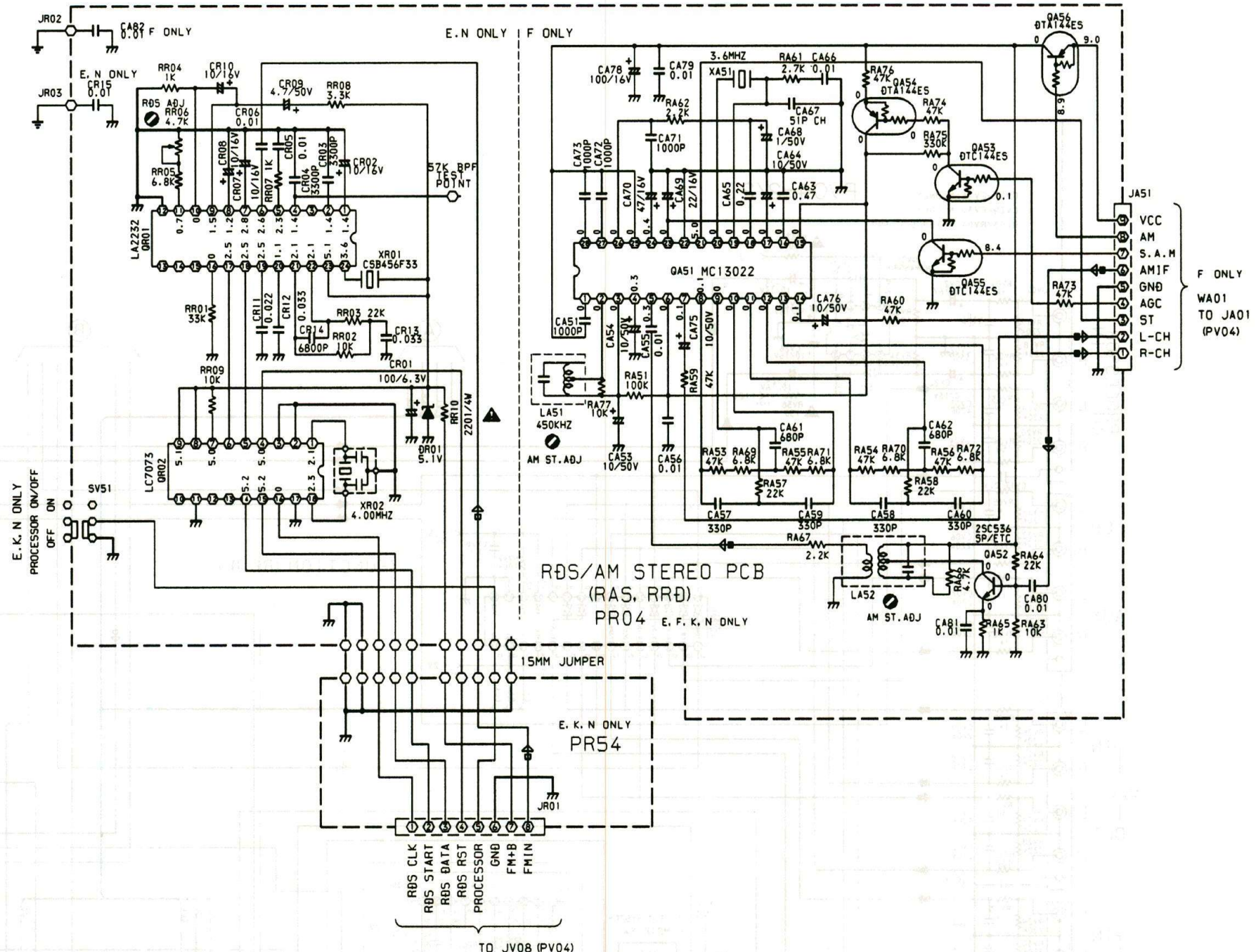
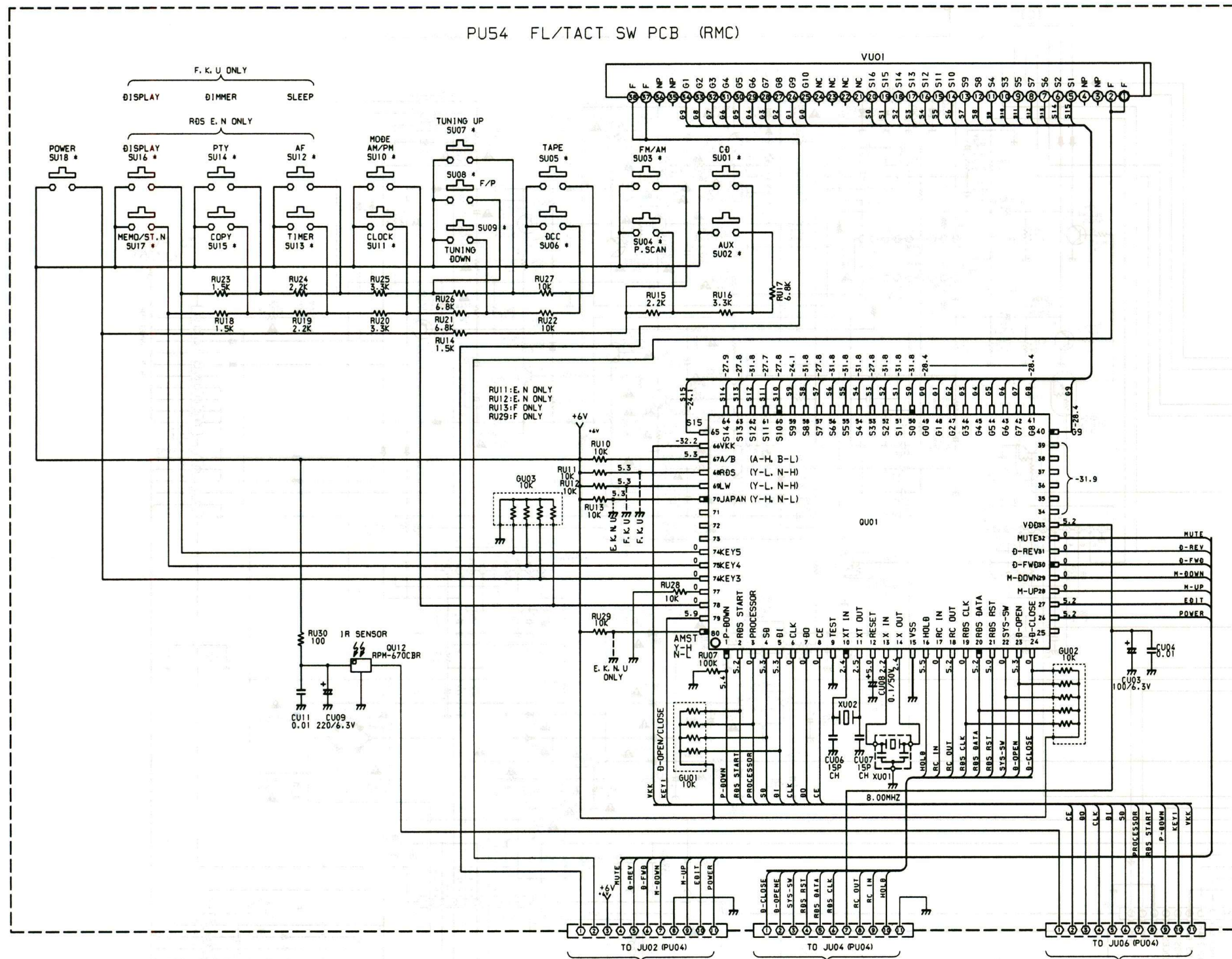

**FL DISPLAY TERMINAL CONNECTION**

PIN NO.	38	37	36	35	34	33	32	31	30	29	28	27	26	25	24	23	22	21	20	19	18	17	16	15	14	13	12	11	10	9	8	7	6	5	4	3	2	1
CONNECTION	F2	F2	NP	NP	1G	2G	3G	4G	5G	6G	7G	8G	9G	10G	NC	NC	NC	NC	P16	P15	P14	P13	P12	P11	P10	P9	P8	P4	P3	P5	P7	P6	P2	P1	NP	NP	F1	F1

- NOTE
1. F1, F2 --- FILAMENT
  2. NP --- NO PIN
  3. NC --- NO CONNECTION
  4. 1G~10G --- GRID
  5. DL --- DATUM LINE

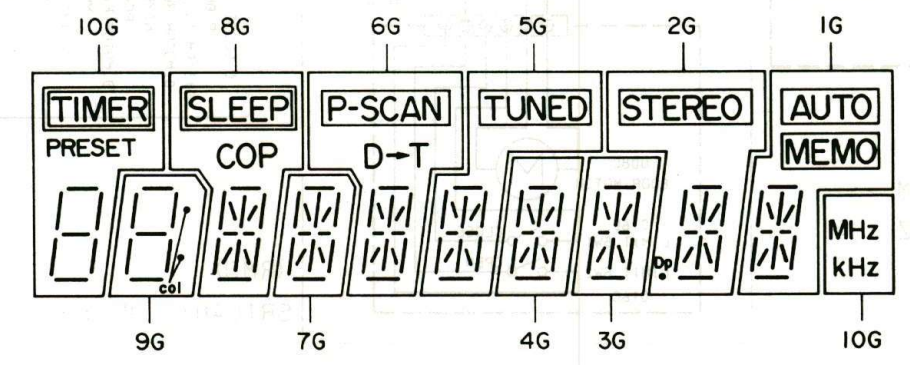



PU54

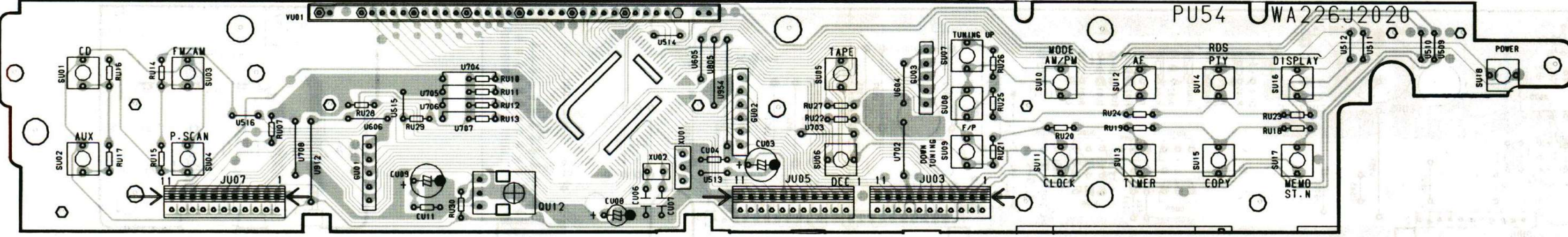

QA52 ~ QA56

QA51

QR01

QR02

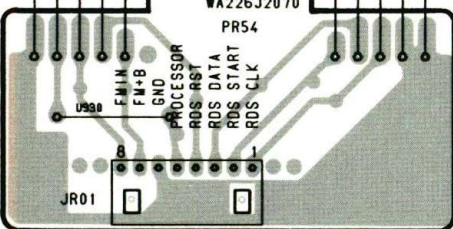
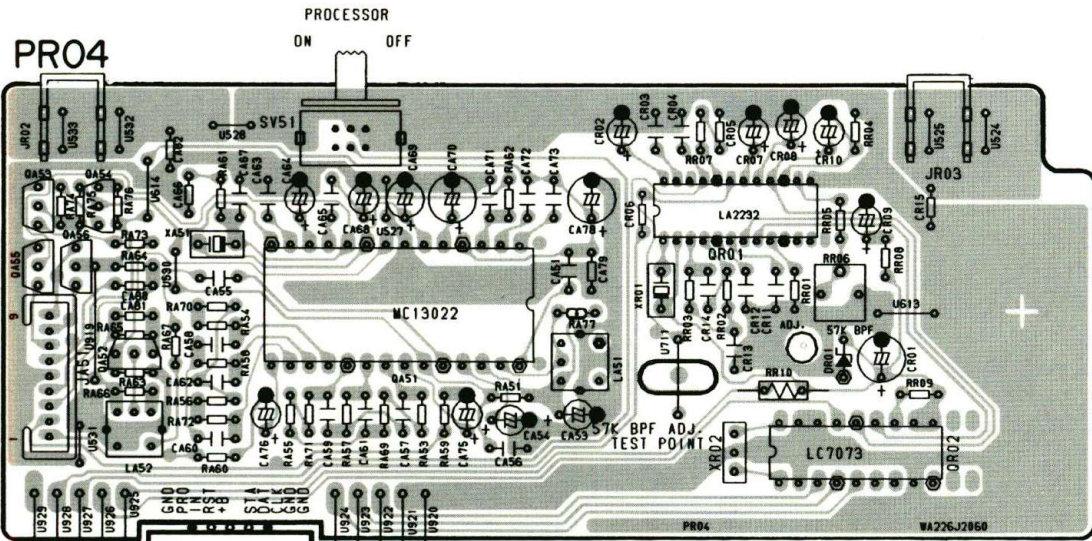

PR54

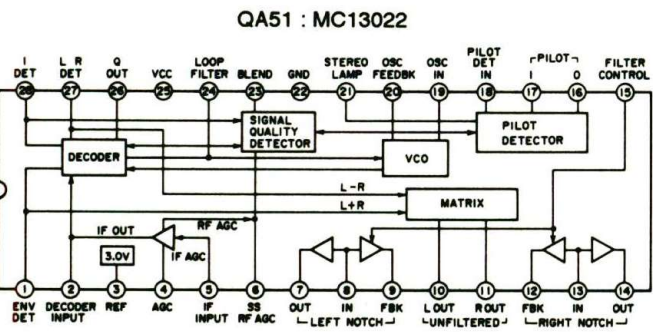

QA51 : MC13022

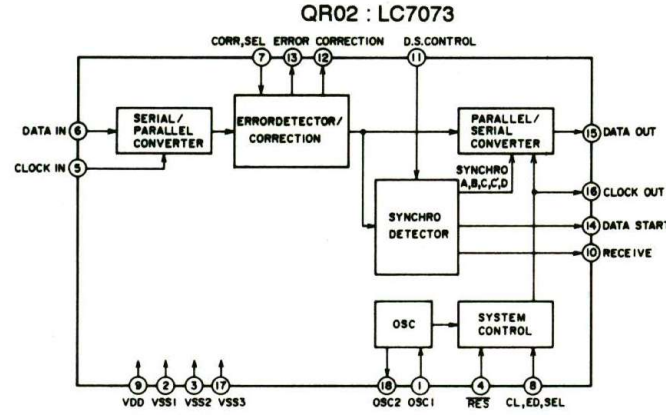

QR02 : LC7073

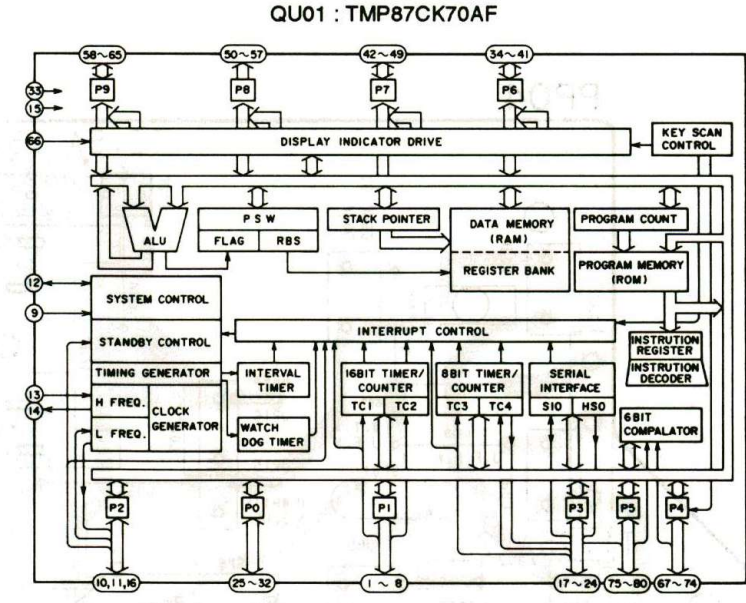

QU01 : TMP87CK70AF

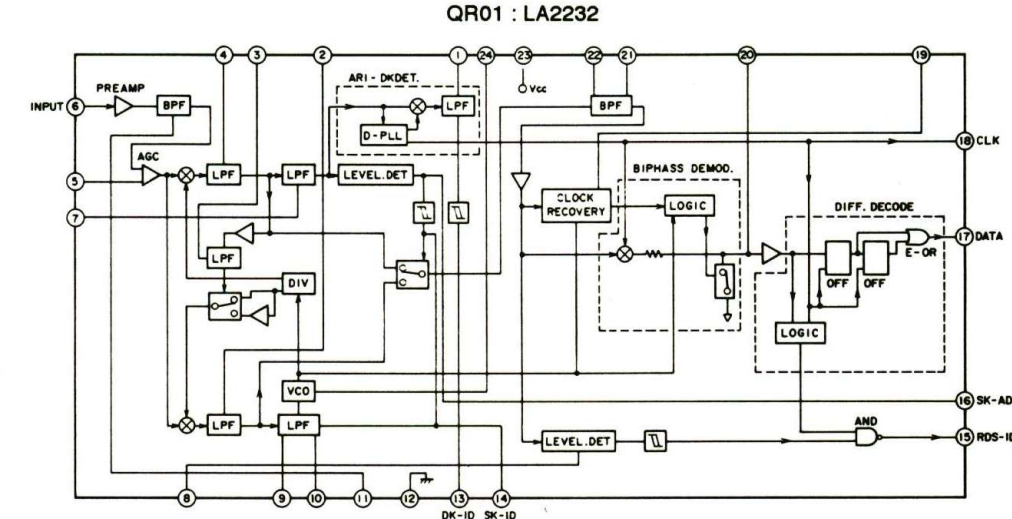

QR01 : LA2232



PU04

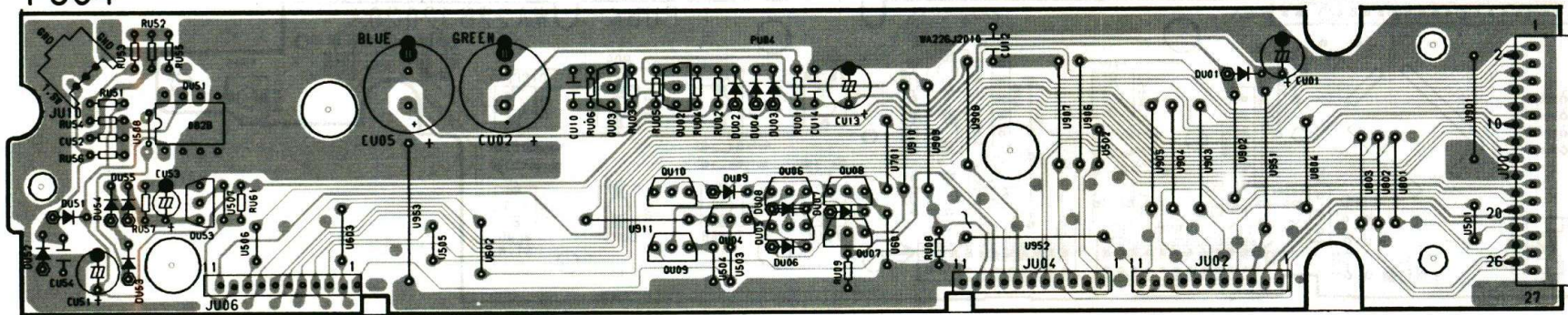

PP54

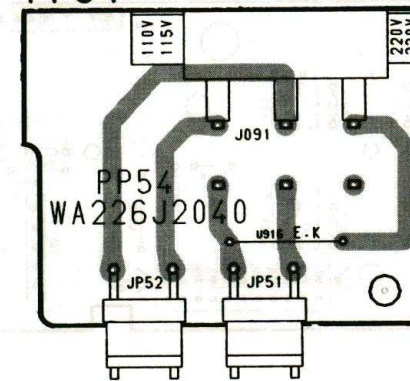

PP04

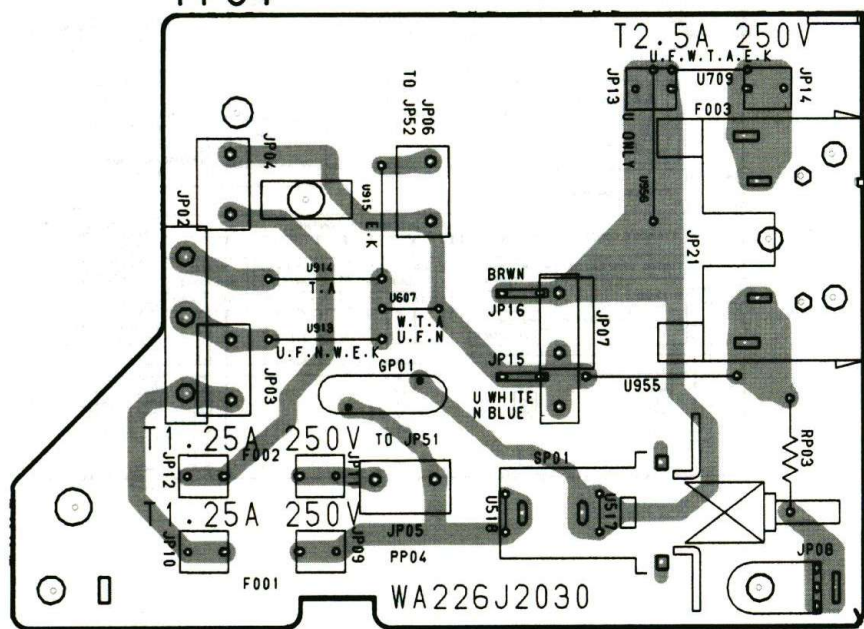



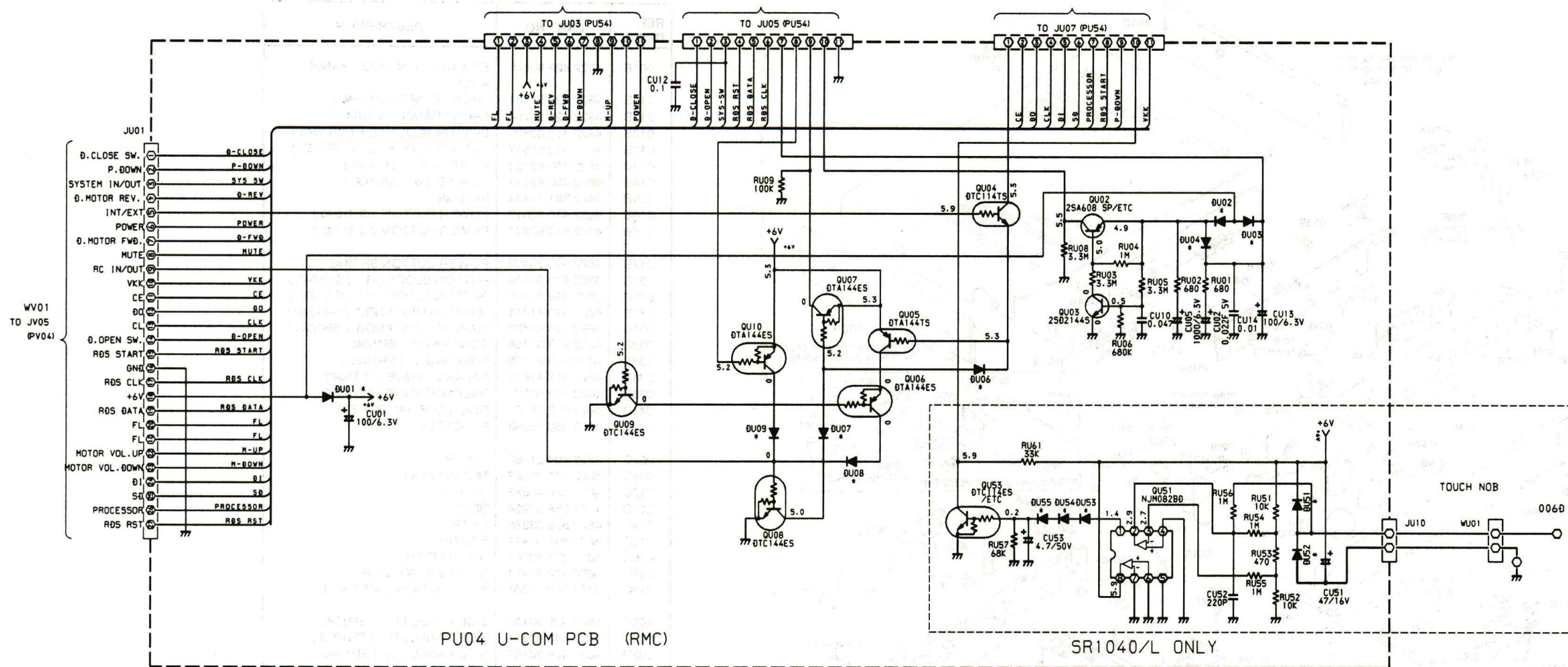

FUNCTION : CØ  
 VOLUME : MINIMUM  
 FM FREQ. : 87.5MHZ  
 ØOR : CLOSE  
 CLOCK : SET

➡ :AUDIO L, R  
 ◻ :FM L, R  
 ◻ :AM L, R

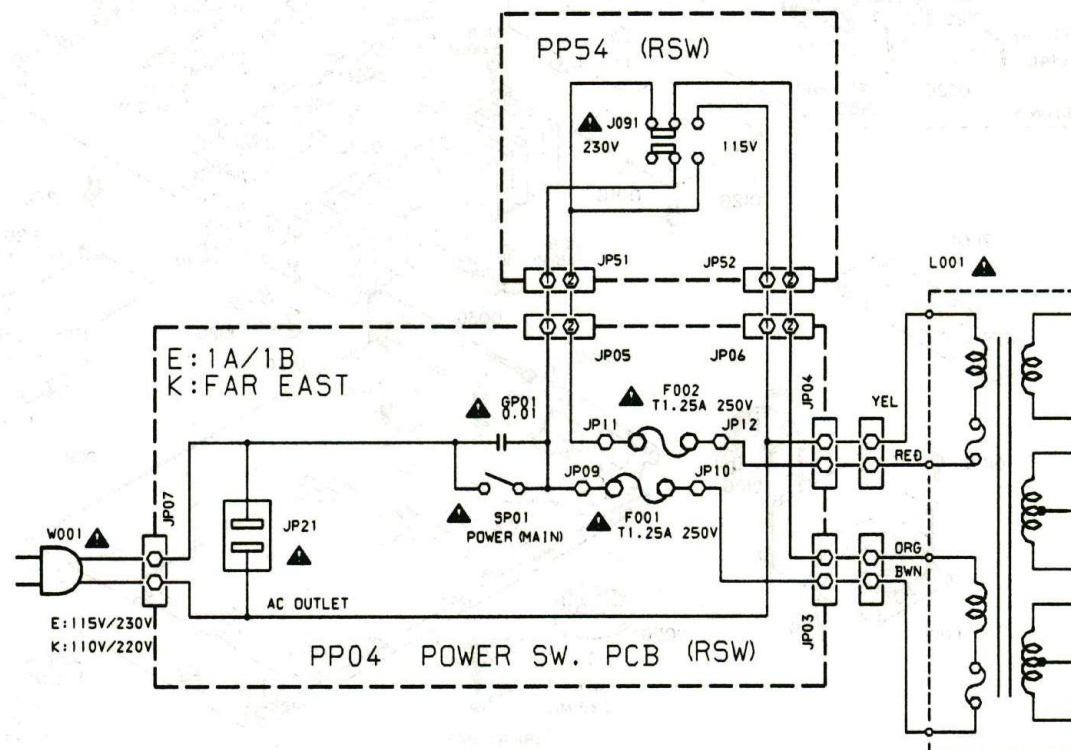
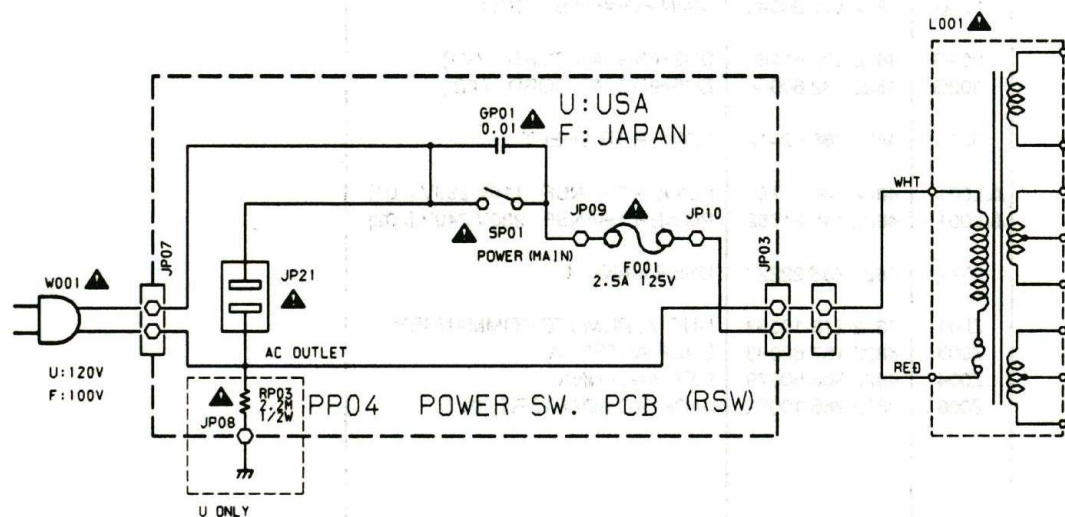



## 4. EXPLODED VIEW AND PARTS LIST

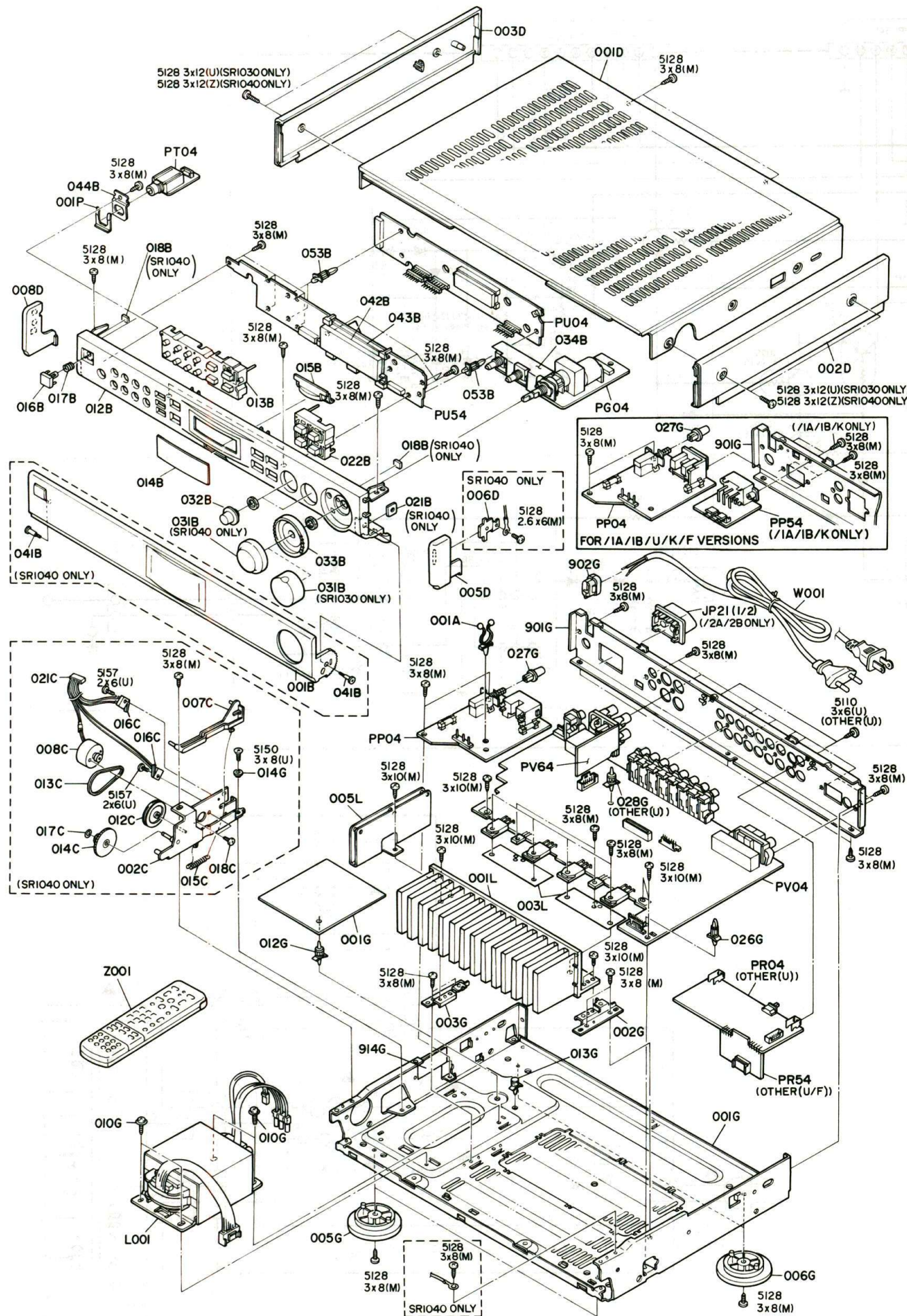

REF. DESIG.	PART NO.	DESCRIPTION
001B	4822 426 60645	ESCUTCHEON, DOOR PANEL ASSY
012B	4822 426 51781	FRONT PANEL ( SR1040 )
012B	4822 426 51784	FRONT PANEL ( SR1030 )
013B	4822 410 63503	BUTTON BLOCK ( L ) ( SR1040 )
013B	4822 410 63507	BUTTON BLOCK ( L ) ( SR1030 )
014B	4822 450 62123	FL WINDOW ( SR1040 )
014B	4822 450 62144	FL WINDOW ( SR1030 )
015B	4822 381 11434	IR LENS
016B	4822 410 62813	POWER BUTTON ( SR1040 )
016B	4822 410 62877	POWER BUTTON ( SR1030 )
017B	4822 492 33409	POWER BUTTON SPRING
022B	4822 410 63504	BUTTON BLOCK ( R ) ( SR1040 )
022B	4822 410 63509	BUTTON BLOCK ( R ) ( SR1030 )
031B	4822 413 41818	MAIN VOLUME KNOB ( SR1040 )
031B	4822 413 41823	MAIN VOLUME KNOB ( SR1030 )
032B	4822 413 31768	TONE KNOB ( SR1040 )
032B	4822 413 31775	TONE KNOB ( SR1030 )
033B	4822 413 41819	BALANCE KNOB ( SR1040 )
033B	4822 413 41822	BALANCE KNOB ( SR1030 )
041B	4822 502 21379	DOOR SPECIAL SCREW
042B	4822 256 92093	FL HOLDER
007C	4822 404 21283	LEVER
008C	4822 361 21687	MOTOR ASSY
012C	4822 528 40363	PULLEY
013C	4822 358 31264	BELT
014C	4822 522 33388	GEAR
015C	4822 492 33411	SPRING
016C	4822 271 30768	MINI SWITCH
017C	4822 462 71954	STOPPER, WASHER
018C	4822 502 21381	P.H.M. SCREW, ( M1.7 x 2 )
002D	4822 426 30156	SIDE PANEL ( R ) ( SR1040 )
002D	4822 443 41304	SIDE PANEL ( R ) ( SR1030 )
003D	4822 426 30157	SIDE PANEL ( L ) ( SR1040 )
003D	4822 443 41305	SIDE PANEL ( L ) ( SR1030 )
005D	4822 532 12253	BUSHING, SIDE ( R ) ( SR1040 )
005D	4822 532 21483	BUSHING, SIDE ( R ) ( SR1030 )
006D	4822 281 50181	TOUCH CONTACTOR ( SR1040 )
008D	4822 532 12254	BUSHING, SIDE ( L ) ( SR1040 )
008D	4822 532 21484	BUSHING, SIDE ( L ) ( SR1030 )
005G	4822 462 42064	LEG, FRONT ( SR1040 )
005G	4822 462 42063	LEG, FRONT ( SR1030 )
006G	4822 462 42065	LEG, REAR ( SR1040 )
006G	4822 462 42051	LEG, REAR ( SR1030 )
010G	4822 502 12511	B.T. SCREW ( W / W ), TRANSF.
027G	4822 410 60343	MAIN POWER BUTTON
902G	4822 532 61184	BUSHING, AC CORD [ / 01 ]
902G	4822 532 60948	BUSHING, AC CORD [ / 02 ]
003L	4822 466 62412	POWER TR SHEET
▲ L001	4822 146 21753	POWER TRANSF., 115V 230V [ / 01 ]
▲ L001	4822 146 21752	POWER TRANSF., 230V 240V [ / 02 ]
001T	4822 736 22227	USER MANUAL
Z001	4822 218 10563	UNIT K, REMOTE COMMANDER
Z003	4822 157 63083	LOOP ANTENNA
Z004	4822 303 50079	EXT. ANTENNA
Z006	4822 265 10092	JACK, AC ADAPTER [ / 01 ]



### ◆アイドリング電流の調整

- (1) 電源を投入しない状態で、マスターボリュームを最小の位置にします。
- (2) 電流調整用半固定抵抗 R719 (Lch)、R720 (Rch) を中央の位置にします。
- (3) セメント抵抗 R737 (Lch)、R738 (Rch) の両端のピンに、デジタル電圧計を接続します。

\* 電源を投入しアイドリング電流を、下表に従って R719、R720 を調整します。

#### 参考

アイドリング電流調整済みのセットを、冷えた状態から電源投入すると、30 秒後に約 3.5mV、1 分後に約 4.5mV に達する。10 分後には平衡状態となり、7mV で安定します。従って、電源投入後、30 秒後～1 分以内に調整作業を行なう場合は「4mV」に調整します。同様に 1 分後～2 分以内の場合は「5mV」に、2 分後～3 分以内の場合は「6mV」に調整します。5 分以降は、設定値である「7mV」に調整します。尚、ヒートラック、エージング後あるいは修理後に調整を行なう場合は、10 分間無信号、無負荷、電源投入状態で放置し、その後設定値である「7mV」に調整します。

## 5. IDLING CURRENT ADJUSTMENT

- (1) Before switching the power ON, set the Master Volume control to the minimum position and the Balance and Tone controls to the center positions.  
Then, rotate the semi-fixed resistors R719 (L CH) and R720 (R CH) on the PC board PV04 center positions.
- (2) Connect a digital voltmeter, set for the DC voltage input to the pertinent test points ( the marked ones of R737-R738) on the PC board PV04.
- (3) After the completion of the above setup.  
Switch the power ON and adjust the semi-fixed resistors R719 ( L CH) and R720 ( R CH ) on the PC board PV04 according to the reading of the digital voltmeter. The setting values are 7 mV ( 19.4 mA ) of the both channels.

#### Note:

When you proceed to this adjustment after having serviced the unit, operate the unit with a non-signal condition for about 15 minutes after turning its power ON, then adjust to 7 mV. If you should proceed to the adjustment in less than 15 minutes after turning the power ON, refer to the following table for the value to be adjusted.

Power ON	
30 sec. ~ 1 min.	4.0 mV
1 min. ~ 2 min.	5.0 mV
2 min. ~ 3 min.	6.0 mV
More than 10 min.	7.0 mV

Measurement point

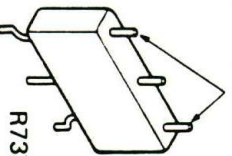

R737/R738

### ◆サービスプログラム

- (1) トラックポイントメモリー  
「MEMO」「TAPE」keys を同時押ししながら「FM/AM」key を押します。下表参照 (FM: JAPAN, AM: 10kHz)

memory を clear する場合は

「MEMO」「TAPE」keys を同時押ししながら「AUX」key を押します。この場合、全ての「RAM Data」が clear されます。

- (2) FL セグメントチェック

「MEMO」「TAPE」キーを同時押ししながら「P. SCAN」を押しします。

all segments が点灯します。この時、function が「TUNER」の場合は約 5 秒後に消灯し、最左端桁より 1 桁ずつ順番に点灯します。「TUNER」以外の function では、全点灯のままです。

segment check mode 中は他の動作は一切しません。power off で cancel されます。

## 6. SERVICE PROGRAM

### 6-1. T.R POINT ME ( tracking point memory ) mode.

While holding the MEMO and TAPE keys depressed simultaneously, press the FM/AM ( MW ) key, the T.R POINT ME mode is called. Frequencies to be memorized are as follows.

	P1	P2	P3	P4	P5	P6	P7
FM [MHz]	90	98	106	87.5			
	USA	90	98	106	87.5		
	JAPAN	78	83	88	76.0		
AM [kHz]	9kHz without LW				603	999	1404
	9kHz with LW				603	999	1404
	10 KHz				600	1000	1400

	P8	P9	P10	P11	P12 ~ P30
AM [kHz]	9kHz without LW	-	-	-	-
	9kHz with LW	171	207	270	152
	10 KHz	-	-	-	531

. : Low end frequency of the AM ( MW ) band.

To clear the entire memory:

While holding the MEMO and TAPE keys depressed simultaneously, press the AUX key. This will clear the RAM data entirely.

### 6-2. FL segment check mode.

While holding the MEMO and TAPE keys depressed simultaneously, press the P. SCAN keys.

All of the display segments light up. If the current input function is TUNER, the segments go off in about 5 seconds then the segments of each display digit light one after another starting with the leftmost digit. If the current input function is other than TUNER, all of the segments remain lit.

No other operation occurs during the segment check mode. This mode can be cancelled by turning the power OFF.



**7. TUNER ALIGNMENT PROCEDURES**

- Set to T.R point ME mode of the service program.
- ( P2 ) to ( P10 ) in the Digital Readout Frequency Setting column shows preset numbers for the above mode.
- Before alignment, connect a dummy resistor of 47 Kohms to the tape output terminal.

**7-1. FM Alignment Procedures**

(Band switch at "FM" position and MODE switch at "MONO" position )

**FM RF Alignment**

Step	Signal Source Connection	Signal Frequency	Indicator Connection	Digital Readout Frequency Setting	Adjust
1	FM signal generator to FM antenna terminal. Adjust the RF signal output so that slight noise occurs at the upper and lower sides of the output waveform.	98.0 MHz	AC VTVM to L-or R-channel Tape out ( JV02 )	98.0 MHz ( P2 )	Front end ( A101 ) IFT for maximum output and minimum distortion.
2	FM signal generator 500 $\mu$ V output to FM antenna terminal ( 75-ohm ).	98.0 MHz	Distortion meter to L-or R-channel Tape out ( JV02 )	98.0 MHz ( P2 )	L201 core for minimum distortion.

**FM IF Alignment**

( Band switch at "FM" position and MODE switch at "AUTO STEREO" position )

Step	Signal Source Connection	Signal Frequency	Indicator Connection	Digital Readout Frequency Setting	Adjust
1	FM signal generator 500 $\mu$ V output modulated by MPX signal generator to FM antenna terminal ( 75-ohm ).	Stereo L-channel ( 1,000 Hz )	VTVM to L-channel Tape out ( JV02 L-channel )	98.0 MHz ( P2 )	Front end ( A101 ) IFT for minimum distortion.
2	Modulation level: IHF 67.5 kHz +9% pilot dev. DIN 40 kHz +8% pilot dev.	Stereo R-channel ( 1,000 Hz )	VTVM to R-channel Tape out ( JV02 R-channel )		

**Muting Level Alignment**

( Band switch at "FM" position and MODE switch at "AUTO STEREO" position )

Step	Signal Source Connection	Signal Frequency	Indicator Connection	Digital Readout Frequency Setting	Adjust
1	FM signal generator 6.3 $\mu$ V output to FM antenna terminal ( 75-ohm )	98.0 MHz	AC VTVM to L-or R-channel Tape out ( JV02 )	98.0 MHz ( P2 )	R212 to a point at which output appears.

**Multiplex Alignment**  
( Band switch at "FM" position and MODE switch at "AUTO STEREO" position )

Step	Signal Source Connection	Signal Frequency	Indicator Connection	Digital Readout Frequency Setting	Adjust
1	FM signal generator 500 $\mu$ V output modulated by MPX signal generator to FM antenna terminal ( 75-ohm ) Modulation level: IHF 67.5 kHz +9% pilot dev. DIN 40 kHz +8% pilot dev.	Stereo L-channel ( 1,000 Hz )	VTVM to R-channel Tape out ( JV02 R-channel )	98.0 MHz ( P2 )	R211 so that channel separation is identical between both channels.
2		Stereo R-channel ( 1,000 Hz )	VTVM to L-channel Tape out ( JV02 L-channel )		
3	Repeat steps 1 and 2				

**RDS 57 KHZ BPF Alignment ( Europe only )**

Step	Signal Source Connection	Signal Frequency	Indicator Connection	Digital Readout Frequency Setting	Adjust
1	FM signal generator 500 $\mu$ V output modulated by MPX signal generator to FM antenna terminal ( 75-ohm ). Modulation level: RDS signal 1 kHz dev.	98.0 MHz	AC VM and Oscilloscope between U711 and GND. ( PR04 )	98.0 MHz	RR06 for maximum output.

**7-2. AM ( MW ) / LW Alignment Procedures**  
( Band switch at "MW" or "AM" position )

**AM IF Alignment**

Step	Signal Source Connection	Signal Frequency	Indicator Connection	Digital Readout Frequency Setting	Adjust
1	Sweep generator to AM antenna terminal.	450 kHz	AC VTVM to L-or R-channel Tape out ( JV02 )	—	LA06 for maximum and symmetrical waveform.

**AM ( MW ) RF Alignment**

Step	Signal Source Connection	Signal Frequency	Indicator Connection	Digital Readout Frequency Setting	Adjust
1	AM signal generator to AM loop antenna in a test loop.	603 kHz ( Europe, Japan ) 600 kHz ( USA )	VTVM to L-or R-channel Tape out ( JV02 )	603 kHz 600 kHz ( P5 )	LA01 for maximum output.
2		1404 kHz ( Europe, Japan ) 1400 kHz ( USA )		1404 kHz 1400 kHz ( P7 )	CA01 for maximum output.
3	Repeat steps 1 and 2 until sensitivity is maximized.				



**AM Auto Stop Alignment ( Band switch at "MW" or "AM" position )**

Step	Signal Source Connection	Signal Frequency	Indicator Connection	Digital Readout Frequency Setting	Adjust
1	RF generator to AM loop antenna in a test loop ( 500 $\mu\text{V} / \text{m}$ )	999 KHz ( Europe, Japan ) 1000 KHz ( USA )	—	999 KHz 1000 KHz ( P6 )	RA11 so that the "TUNED" on the display tube lights.

**LW RF Alignment (Europe only )**

Step	Signal Source Connection	Signal Frequency	Indicator Connection	Digital Readout Frequency Setting	Adjust
1	AM signal generator to AM loop antenna in a test loop.	171 KHz	VTVM to L-or R-channel Tape out ( JV02 )	171 KHz ( P8 )	LA03 for maximum output.
2		270 KHz		270 KHz ( P10 )	CA08 for maximum output.
3	Repeat steps 1 and 2 until sensitivity is maximized.				

**AM Stereo 調整 (Japan only)**

調整箇所 : LA51, LA52, LA06

調整周波数 : 999 kHz, 50mV/m (94 dB/m)

変調条件 : 400 Hz (L+R) = 30% MOD.

25 Hz PILOT=5% MOD.

1. SGの変調を「L-R」(SUB), PILOT-OFFにする。
2. セットのLch (又はRch) の出力が最小になるように、LA51, LA52 を調整、LA06 を微調整する。(注)

\*MODE SW は、「AUTO」ポジションとする。

(注) LA52の調整はフロードであり、セットの出力変化は極僅かです。

**8. ALIGNMENT AND TEST POINT**

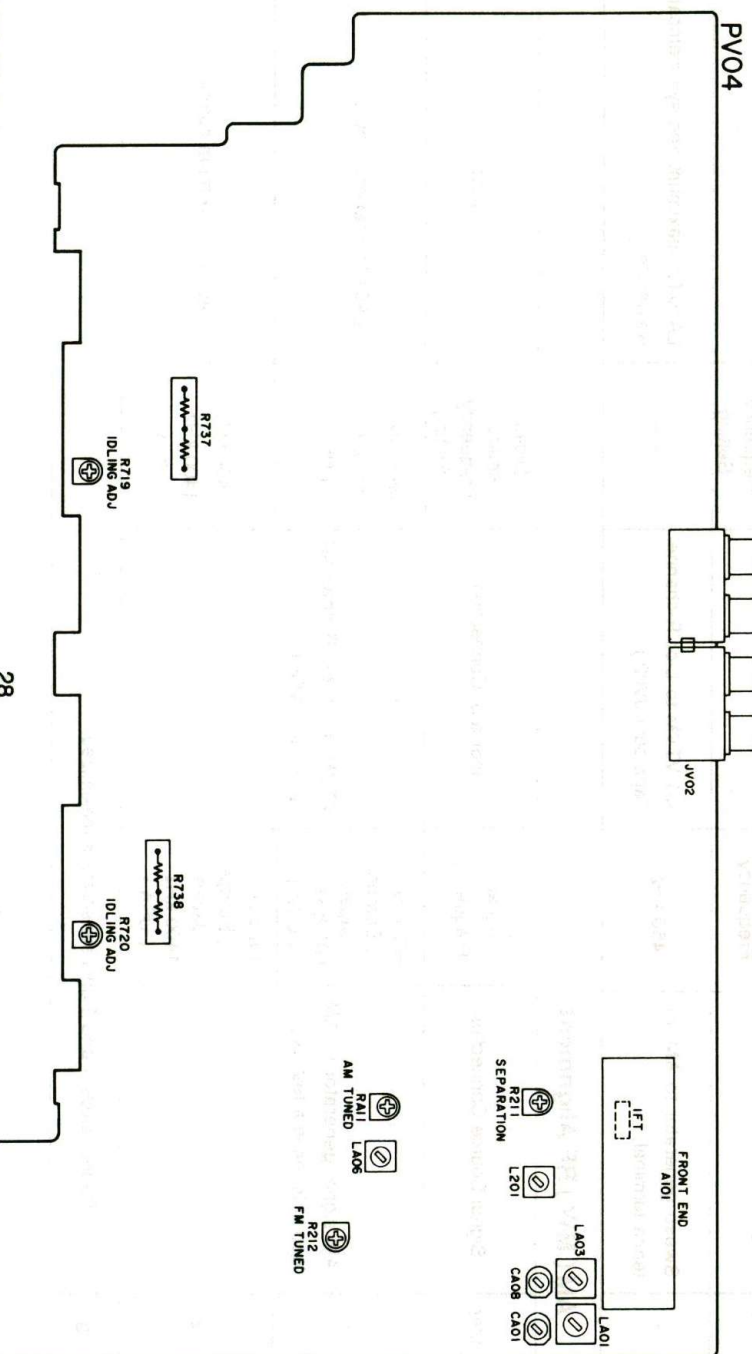



9. MICROPROCESSOR SPECIFICATIONS

Receiving Frequency Range, Channel Space, Reference Frequency and Intermediate Frequency

		Receiving Frequency	Channel Space	Reference Frequency	Intermediate Frequency
Europe	FM	87.5 ~ 108.0 MHz	50 kHz	25 kHz	+10.7 MHz
	MW	531 ~ 1602 kHz	9 kHz	9 kHz	+450 kHz
	LW	152 ~ 282 kHz	1 kHz	1 kHz	+450 kHz
U.S.A.	FM	87.5 ~ 108.0 MHz	100 kHz	25 kHz	+10.7 MHz
	AM	520 ~ 1710 kHz	10 kHz	10 kHz	+450 kHz
Japan	FM	76.0 ~ 90.0 MHz	100 kHz	25 kHz	-10.7 MHz
	AM	531 ~ 1602 kHz	9 kHz	9 kHz	+450 kHz

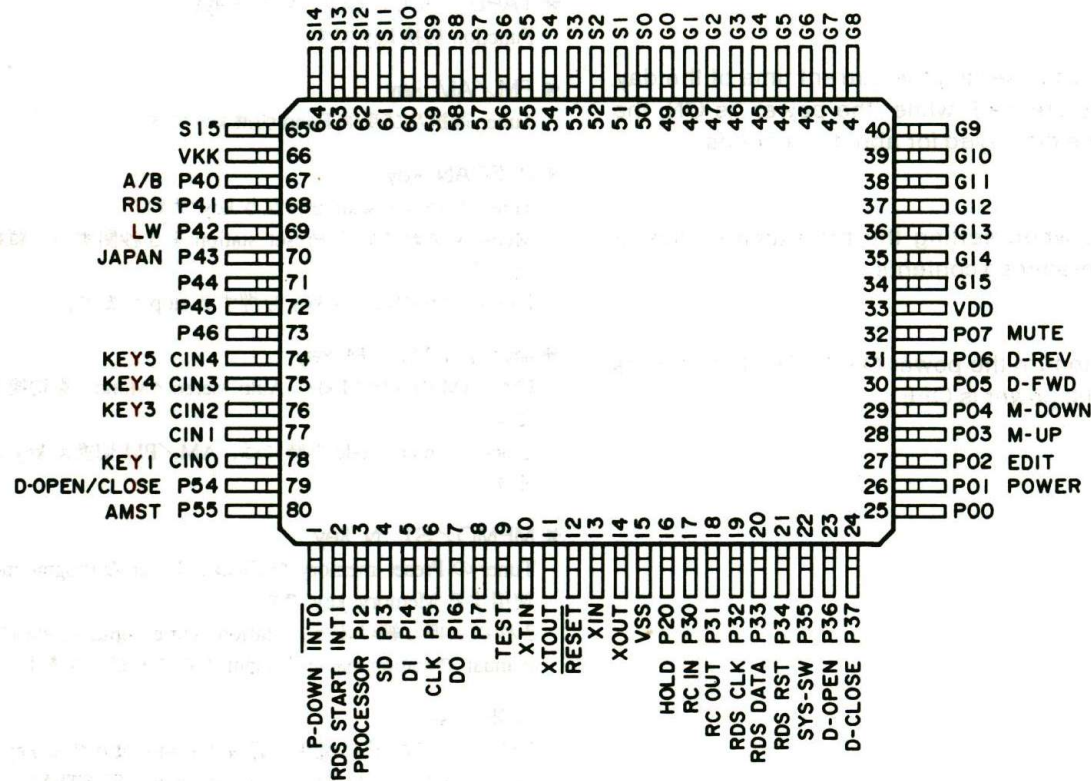

TMP87CK70AF

Pin No.	Pin name	I/O	Action	Function	Pin No.	Pin name	I/O	Action	Function			
1	INT0		I	H	Power down signal	41	G8		G8	0	H	FTD 2G digit
2	INT1		I	L	RDS Data start	42	G7		G7	0	H	FTD 3G digit
3	P12		I	H	Processor SW	43	G6		G6	0	H	FTD 4G digit
4	P13		I	L	SD in	44	G5		G5	0	H	FTD 5G digit
5	P14		I	H	DI in	45	G4		G4	0	H	FTD 6G digit
6	P15		O	H	Clock out	46	G3		G3	0	H	FTD 7G digit
7	P16		O	H	Data out	47	G2		G2	0	H	FTD 8G digit
8	P17		O	H	CE out	48	G1		G1	0	H	FTD 9G digit
9	TEST		I	-	Not used	49	G0		G0	0	H	FTD 10G digit
10	XT in		I	-	Sub clock,32.768kHz	50	S0		S0	0	H	FTD S16 segment
11	XT out		O	-	Sub clock	51	S1		S1	0	H	FTD S15 segment
12	RESET		I	L	Reset	52	S2		S2	0	H	FTD Sr segment
13	X in		I	-	Main clock, 8.0MHz	53	S3		S3	0	H	FTD Sp segment
14	X out		O	-	Main clock	54	S4		S4	0	H	FTD Sn segment
15	Vss		-	-	GND	55	S5		S5	0	H	FTD Sm segment
16	P20		I	H	Hold	56	S6		S6	0	H	FTD Sk segment
17	P30		I	H	RC-5 in	57	S7		S7	0	H	FTD Sj segment
18	P31		O	L	RC-5 out	58	S8		S8	0	H	FTD Sh segment
19	P32		I	L	RDS clock in	59	S9		S9	0	H	FTD Sd segment
20	P33		I	L	RDS data in	60	S10		S10	0	H	FTD Sc segment
21	P34		O	L	RDS reset out	61	S11		S11	0	H	FTD Se segment
22	P35		I	H	System SW	62	S12		S12	0	H	FTD Sg segment
23	P36		I	L	Door open SW	63	S13		S13	0	H	FTD Sf segment
24	P37		I	L	Door close SW	64	S14		S14	0	H	FTD Sb segment
25	P00		O	-	Not used	65	S15		S15	0	H	FTD Sa segment
26	P01		O	H	Power relay drive	66	Vkk		Vkk	-	-	-30V
27	P02		O	L	Edit	67	P40		A/B	I	-	MODEL
28	P03		O	H	Motor volume up	68	P41		RDS	I	L	*RDS
29	P04		O	H	Motor volume down	69	P42		LW	I	L	*LW
30	P05		O	H	Door motor forward	70	P43		JAPAN	I	H	*JAPAN
31	P06		O	H	Door motor reverse	71	P44			O	-	Not used
32	P07		O	H	Muting	72	P45			O	-	Not used
33	Vdd		-	-	+5V	73	P46			-	-	Not used
34	G15		O	-	Not used	74	CIN4		KEY5	I	-	Key SW 5
35	G14		O	-	Not used	75	CIN3		KEY4	I	-	Key SW 4
36	G13		O	-	Not used	76	CIN2		KEY3	I	-	Key SW 3
37	G12		O	-	Not used	77	CIN1			I	-	Not used
38	G11		O	-	Not used	78	CIN0		KEY1	I	-	Key SW 1
39	G10		O	-	Not used	79	P54		D-OPEN/ CLOSE	I	L	Door key SW
40	G9		O	H	FTD 1G digit	80	P55		AMST	I	H	* AM stereo SELECT



## Key Matrix

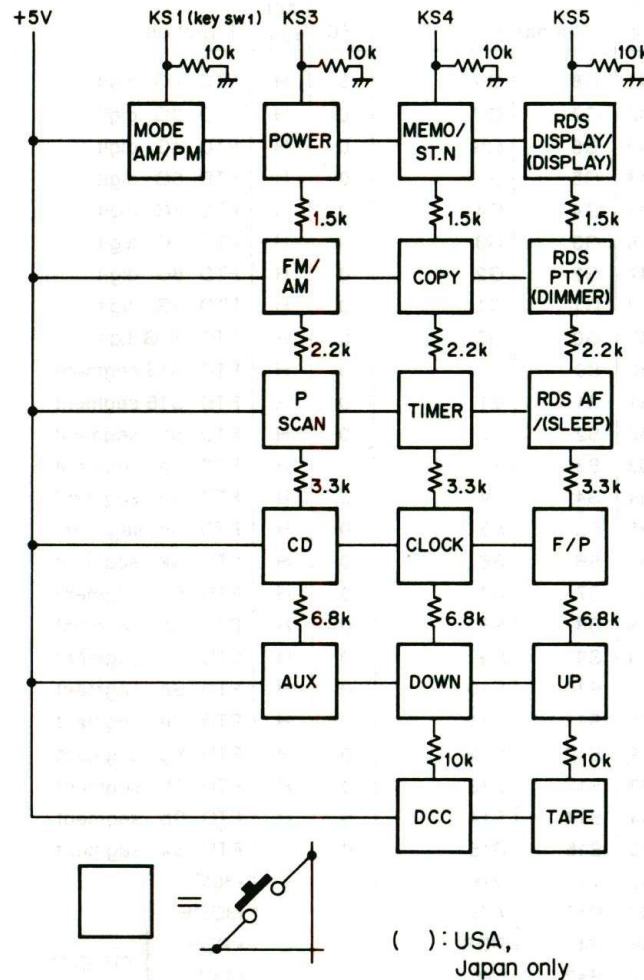

## Description of Keys

**\* RDS DISPLAY/( DISPLAY ) key**

This key is used to switch the information shown on the display. It is valid only during tuner reception. Usually, the display shows the station name but the frequency appears when the key is pressed. During reception of a station without station name, its frequency is displayed. If this key is pressed then, "NO NAME" will be displayed for about 2 second.

**\* RDS PTY/( DIMMER ) key**

This key is used to select the PTY ( Programme Type ). When this key is pressed during reception of an RDS station, the PTY of the station being received will be displayed for about 5 seconds. If the UP or DOWN key is pressed after displaying the PTY, the PTY auto search starts and stops only when a station of the same PTY is received. In case of "without RDS", this key functions as the Dimmer key, which varies ( dims ) the display brightness when it is pressed.

**\* RDS AF/( SLEEP ) key**

This key is used to switch the station being received to an AF ( Alternative Frequencies ) station. When the key is pressed during reception of an RDS station, a station broadcasting the same programme will be received. If there is no AF station to the original station, "NO AF" will be displayed. In case of "without RDS", this key functions as the Sleep key, which allow to set the sleep timer.

**\* F / P key**

This key is used to switch the function of the UP / DOWN keys between the Frequency up / down keys and Preset up / down keys.

**\* UP / DOWN keys**

These keys are used to increase or decrease the frequency or preset number. In the clock and timer modes, these keys are used to set the time, programme, etc.

**\* TAPE, DCC, CD and AUX keys**

These keys are used to select the input function.

**\* FM / AM keys**

This key is used to select the tuner mode and the receiving band. In case the LW band is available, this key functions as the FM / MW / LW band selector keys.

**\* P. SCAN key**

This key is used to initiate the preset scanning of radio stations. With preset scanning, the preset stations in memory are received sequentially for 5 seconds per each station. When this key is pressed again, the preset scanning stops at that point.

**\* MODE AM / PM key**

This key is usually used as the MODE key for selecting the FM reception mode ( Auto stereo / Mono ). In the clock and timer modes, this key functions as the AM / PM selector key.

**\* MEMO / ST. N key**

This key is usually used as the MEMO key for use in storing preset stations in memory or programming of the clock or timer. When the key is held depressed for more than 3 seconds, the station name input mode is initiated and this key allows to input the station name manually.

**\* COPY key**

This key is used to initiate direct recording from DCC to TAPE. This key is invalid if D. BUS switch on the rear panel is set to SYSTEM.

**\* CLOCK key**

This key is used when setting the current time of the day. When this key is pressed while the power is ON, the current time will be displayed for about 3 seconds.

**\* TIMER key**

This key is used when setting the programme timer or checking the programmed contents.

**\* POWER key**

This key is used to turn the power ON / OFF. The clock is displayed while the power is OFF.

**\* DISPLAY key**

DISPLAY 部の表示を切替る Key です。チューナ受信時のみ有効です。

**\* DIMMER key**

Key を押すと表示部の明るさが変化 ( 暗くなる ) します。

**\* SLEEP key**

Sleep key で Sleep timer を設定することができます。

**\* F / P key**

UP / DOWN keys を、Frequency up / down か Preset up / down かに切替る key です。

**\* UP / DOWN keys**

Frequency Preset number の up / down key です。Clock、Timer mode の時には、Time、Programme 等の設定 keys になります。

**\* TAPE、DCC、CD、AUX keys**

Function 切替 key です。

**\* FM / AM key**

Tuner 選択及び受信 Band 切替 key です。

**\* P. SCAN key**

Tuner の Preset scan を行なう key です。Memory されている Preset station を 5 秒間ずつ、順番に受信します。Preset scan 中に再度 key を押すと stop します。

**\* MODE AM / PM key**

FM / AM の受信 Mode ( Auto stereo / Mono ) を切替る key です。Clock、Timer mode の時には、AM / PM 切替 key になります。

**\* MEMO / ST. N key**

Tuner の Preset memory や Clock、Timer の Programme 等に使用する Memory key です。3 秒以上押し続けると、Station name input mode になり、manual で station name を input することができます。

**\* COPY key**

DCC から TAPE に直接、録音する時に使用する key です。Rear panel の「D. BUS」の Switch が「SYSTEM」に切替えてある時には、無効 key となります。

**\* CLOCK key**

現時刻を設定する時に使用する key です。又、Power on 中に key を押すと表示部に約 3 秒間現時刻が表示されます。

**\* TIMER key**

Programme timer の設定や Programme 内容の確認を行なう key です。

**\* POWER key**

Power on / off key です。power off 時は時計表示となります。



# 10. ELECTRICAL PARTS LIST

## ASSIGNMENT OF COMMON PARTS CODES.

### RESISTOR

- R\*\*\* : 1) GD05 x x x 140, Carbon film fixed resistor, ± 5% 1/4W
- R\*\*\* : 2) GD05 x x x 160, Carbon film fixed resistor, ± 5% 1/6W

(1) — Resistance value

Examples :

(1) Resistance value

0.1Ω...001	10Ω...100	1kΩ...102	100kΩ...104
0.5Ω...005	18Ω...180	2.7kΩ...272	680kΩ...684
1Ω...010	100Ω...101	10kΩ...103	1MΩ...105
6.8Ω...068	390Ω...391	22kΩ...223	4.7MΩ...475

(Note) Please distinguish 1/4W from 1/6W by the shape of parts used actually.

### C\*\*\* : CERAMIC CAP.

- 1) DD1 x x x x 370, Ceramic capacitor  
Disc type  
Temp.coeff.P350~N1000.50V
- (1) Capacity value  
(2) Tolerance

Examples

- (1) Tolerance (Capacity deviation)
  - ± 0.25pF ... 0
  - ± 0.5pF ... 1
  - ± 5% ... 5

\* Tolerance of COMMON PARTS handled here are as follows :

- 0.5pF~ 5pF...± 0.25pF
- 6pF~ 10pF...± 0.5pF
- 12pF~ 560pF...± 5%

(2) Capacity value

0.5pF...005	3pF...030	100pF...101
1pF...010	10pF...100	220pF...221
1.5pF...015	47pF...470	560pF...561

### C\*\*\* : CERAMIC CAP

- 1) DK16 x x x 300, High dielectric constant ceramic capacitor  
Disc type  
Temp.chara. 2B4, 50V
- (1) Capacity value

Examples

- (2) Capacity value
  - 100pF...101
  - 470pF...471
  - 1000pF...102
  - 2200pF...222
  - 10000pF...103

### C\*\*\* : ELECTROLY CAP. ( ), FILM CAP. ( )

- 1) EA x x x x x 10, Electrolytic capacitor  
One-way lead type, Tolerance ± 20%
- (1) Working voltage  
(2) Capacity value

Examples

- (1) Capacity value
  - 0.1 μF...104
  - 0.33 μF...334
  - 1 μF...105
  - 4.7 μF...475
  - 10 μF...106
  - 22 μF...226
  - 100 μF...107
  - 330 μF...337
  - 1100 μF...118
  - 2200 μF...228

(2) Working voltage

6.3V...006	25V...025
10V...010	35V...035
16V...016	50V...050

- 2) DF15 x x x 350 } Plastic film capacitor
  - DF15 x x x 310 } One-way type, Mylar ± 5% 50V
  - DF16 x x x 310 } Plastic film capacitor
  - One-way type, Mylar ± 10% 50V
- (1) Capacity value

Examples

- (1) Capacity value
  - 0.001 μF (1000pF)...102
  - 0.0018 μF...182
  - 0.01 μF...103
  - 0.015 μF...153
  - 0.1 μF...104
  - 0.56 μF...564
  - 1 μF...105

- NOTE** : 1) The above CODES ( R\*\*\*, R\*\*\*, C\*\*\*, C\*\*\* and C\*\*\* ) are omitted on the schematic diagram in some case.  
2) On the occasion, be confirmed the common parts on the parts list.  
3) Refer to "Common Parts List" for the other common parts( RI05, DD4, DK4 ).

## NOTE ON SAFETY FOR FUSIBLE RESISTOR :

The suppliers and their type numbers of fusible resistors are as follows :

### 1. KOA Corporation

Part No.	Type No.	Description
NH05 x x x 140	RF25S x x x x Ω J	( ± 5% 1/4W )
NH05 x x x 120	RF50S x x x x Ω J	( ± 5% 1/2W )
NH85 x x x 110	RF73B2A x x x x Ω J	( ± 5% 1/10W )
NH95 x x x 140	RF73B2E x x x x Ω J	( ± 5% 1/4W )

\* Resistance value (0.1 - 10kΩ)

### 2. Matsushita Electronic Components Co., Ltd

Part No.	Type No.	Description
NF05 x x x 140	ERD-2FCJ x x x	( ± 5% 1/4W )
RF05 x x x 140		
NF02 x x x 140	ERD-2FCG x x x	( ± 2% 1/4W )
RF02 x x x 140		

\* Resistance value

Examples :

\* Resistance value

0.1Ω...001	10Ω...100	1kΩ...102	100kΩ...104
0.5Ω...005	18Ω...180	2.7kΩ...272	680kΩ...684
1Ω...010	100Ω...101	10kΩ...103	1MΩ...105
6.8Ω...068	390Ω...391	22kΩ...223	4.7MΩ...475

## NOTE ON SAFETY :

Symbol ▲ Fire or electrical shock hazard. Only original parts should be used to replaced any part marked with symbol ▲. Any other component substitution ( other than original type), may increase risk of fire or electrical shock hazard.



REF. DESIG.	PART NO.	DESCRIPTION	REF. DESIG.	PART NO.	DESCRIPTION
		<b>PG04-MOTOR VOLUME AND TONE CONTROL CIRCUIT BOARD</b>			<b>PR04-RDS / AM STEREO CIRCUIT BOARD</b>
		<b>PG04-CAPACITORS</b>			<b>PR04-CAPACITORS</b>
CE01	4822 126 10408	CERAMIC 220 $\mu$ F $\pm$ 10% 25V	CR01	4822 126 10935	ELECT 100 $\mu$ F 6.3V
CE02	4822 126 10408	CERAMIC 220 $\mu$ F $\pm$ 10% 25V	CR02	4822 124 21894	ELECT 10 $\mu$ F 16V
CE09	4822 124 23056	ELECT 47 $\mu$ F 16V	CR05	4822 122 40586	CERAMIC 0.01 $\mu$ F $\pm$ 20% 25V
CE10	4822 124 23056	ELECT 47 $\mu$ F 16V	CR06	4822 122 40586	CERAMIC 0.01 $\mu$ F $\pm$ 20% 25V
CE15	4822 124 23055	ELECT 22 $\mu$ F 16V	CR07	4822 124 21894	ELECT 10 $\mu$ F 16V
CE16	4822 124 23055	ELECT 22 $\mu$ F 16V	CR08	4822 124 21894	ELECT 10 $\mu$ F 16V
CE17			CR09	4822 124 23057	ELECT 4.7 $\mu$ F 50V
?	4822 124 21894	ELECT 10 $\mu$ F 16V	CR10	4822 124 21894	ELECT 10 $\mu$ F 16V
CE20			CR11	4822 122 30103	CERAMIC 0.022 $\mu$ F +80% -20% 50V
CG01	4822 122 30103	CERAMIC 0.022 $\mu$ F +80% -20% 50V	U526	4822 122 40586	CERAMIC 0.01 $\mu$ F $\pm$ 20% 25V
CG05	4822 124 23052	ELECT 100 $\mu$ F 16V	U529	4822 122 40586	CERAMIC 0.01 $\mu$ F $\pm$ 20% 25V
		<b>PG04-CAPACITORS ( COMMON )</b>			<b>PR04-CAPACITORS ( COMMON )</b>
C***		PLASTIC FILM CAPACITOR, $\pm$ 5% 50V : CE05~CE08, CE11~CE14	C***		HIGH DIELECTRIC CONSTANT CERAMIC CAPACITOR, $\pm$ 10% 50V : CR03, CR04
		<b>PG04-RESISTORS</b>			PLASTIC FILM CAPACITOR, $\pm$ 5% 50V : CR12~CR14
▲RE01	4822 052 10151	150 $\Omega$ $\pm$ 5% 1/6W	C***		
▲RE02	4822 052 10151	150 $\Omega$ $\pm$ 5% 1/6W			
RE19	4822 101 30834	10K $\Omega$ ( E ) VARIABLE			
RE20	4822 101 30834	10K $\Omega$ ( E ) VARIABLE			
RG01	4822 101 30835	100K $\Omega$ ( B ) X2/100K ( W ) VARIABLE	RR06	4822 100 11373	4.7K $\Omega$ , TRIMMING
			RR10	4822 116 83929	220 $\Omega$ $\pm$ 5% 1/4W
		<b>PG04-RESISTORS ( COMMON )</b>			<b>PR04-RESISTORS ( COMMON )</b>
R***		CARBON FILM FIXED RESISTOR, $\pm$ 5% 1/6W : RE05~RE18, RE21~RE24, CG03, CG04	R***		CARBON FILM FIXED RESISTOR, $\pm$ 5% 1/6W : RR01~RR05, RR07~RR09
		<b>PG04-SEMICONDUCTORS</b>			<b>PR04-SEMICONDUCTORS</b>
DE01	4822 130 32508	DIODE RL103E / DSF10C	DR01	4822 130 80317	ZENER DIODE 5.1V
QE01	4822 209 73064	IC NJM2068DD	QR01	4822 209 32706	IC LA2232
QE02	4822 130 60766	DIGITAL TRANSISTOR DTA114ES/ UN4111	QR02	4822 209 33818	IC LC7073
		<b>PG04-MISCELLANEOUS</b>			<b>PR04-MISCELLANEOUS</b>
LE01	4822 280 20501	RELAY MR62-24SR	SV51	4822 277 21712	SLIDE SWITCH, PROCESSOR ON / OFF
		<b>PP04-POWER SW CIRCUIT BOARD</b>			
		<b>PP04-CAPACITOR</b>			
▲GP01	4822 122 33276	CERAMIC 0.01 $\mu$ F $\pm$ 20% 400V			
		<b>PP04-MISCELLANEOUS</b>			
▲F001	4822 070 31252	FUSE 1.25A 250V			
▲F002	4822 070 31252	FUSE 1.25A 250V [ /01 ]			
▲F003	4822 253 40166	FUSE T2.5A 250V [ /02 ]	C***		<b>PT04-HEADPHONE CIRCUIT BOARD</b>
▲JP21	4822 267 31686	JACK, AC OUTLET 1P [ /01 ]			<b>PT04-CAPACITORS ( COMMON )</b>
▲JP21	4822 267 31687	JACK, AC OUTLET 1P [ /02 ]			HIGH DIELECTRIC CONSTANT CERAMIC CAPACITOR, $\pm$ 10% 50V : ( CT01, CT02 [ /02 ] )
▲SP01	4822 276 12924	PUSH SWITCH, POWER	JT01	4822 267 31685	<b>PT04-MISCELLANEOUS</b> JACK, HEADPHONE
		<b>PP54-VOLTAGE SELECTOR CIRCUIT BOARD</b>			
▲J091	4822 277 21763	SLIDE SWITCH [ /01 ]			



REF. DESIG.	PART NO.	DESCRIPTION
		<b>PU04-<math>\mu</math>-COM CIRCUIT BOARD</b>
		<b>PU04-CAPACITORS</b>
CU01	4822 126 10935	ELECT 100 $\mu$ F 6.3V
CU02	4822 124 23295	BIG ELECT 0.022F 5V
CU05	4822 126 12867	ELECT 1000 $\mu$ F 6.3V
CU12	4822 122 40617	CERAMIC 0.1 $\mu$ F +80% -20% 50V
CU51	4822 124 23056	ELECT 47 $\mu$ F 16V (SR1040)
CU52	4822 126 10408	CERAMIC 220PF $\pm$ 10% 25V (SR1040)
CU53	4822 124 23057	ELECT 4.7 $\mu$ F 50V (SR1040)
		<b>PU04-CAPACITORS (COMMON)</b> PLASTIC FILM CAPACITOR, $\pm$ 5% 50V : CU10
		<b>PU04-RESISTORS</b>
RU03	4822 050 23308	3.3M $\Omega$ $\pm$ 5% 1/6W
RU05	4822 050 23308	3.3M $\Omega$ $\pm$ 5% 1/6W
RU08	4822 050 23308	3.3M $\Omega$ $\pm$ 5% 1/6W
		<b>PU04-RESISTORS (COMMON)</b> CARBON FILM FIXED RESISTOR, $\pm$ 5% 1/6W : RU01, RU02, RU04, RU06, RU07, RU09, (RU51~RU57, RU61, SR1040)
		<b>PU04-SEMICONDUCTORS</b>
DU01 }	4822 130 33305	DIODE 1SS176, MA165, 1SS254
DU04 DU06 }	4822 130 33305	DIODE 1SS176, MA165, 1SS254
DU09 DU51 }	4822 130 33305	DIODE 1SS176, MA165, 1SS254 (SR1040)
QU02	4822 130 42715	TRANSISTOR 2SA608SP, 2SA1048, 2SA1309, 2SA933S
QU03	4822 130 61892	TRANSISTOR 2SD2144S (U, V)
QU04	4822 130 61189	DIGITAL TRANSISTOR DTC114TS
QU05	4822 130 61187	DIGITAL TRANSISTOR DTA144TS
QU06	4822 130 42682	DIGITAL TRANSISTOR DTA144ES/ UN4113
QU07	4822 130 42682	DIGITAL TRANSISTOR DTA144ES/ UN4113
QU08	4822 130 42594	DIGITAL TRANSISTOR DTC144ES/ UN4213
QU09	4822 130 42594	DIGITAL TRANSISTOR DTC144ES/ UN4213
QU10	4822 130 42682	DIGITAL TRANSISTOR DTA144ES/ UN4113
QU51	4822 209 63468	IC NJM082D (SR1040)
QU53	4822 130 60588	DIGITAL TRANSISTOR DTC114ES/ UN4211 (SR1040)
		<b>PU04-MISCELLANEOUS</b>
JU01		CONNECTOR, CARD FIT 27P
XU02	4822 242 72236	CRYSTAL 32.768KHZ

REF. DESIG.	PART NO.	DESCRIPTION
		<b>PU54-DISPLAY AND SWITCH CIRCUIT BOARD</b>
		<b>PU54-CAPACITORS</b>
CU03	4822 126 10935	ELECT 100 $\mu$ F 6.3V
CU04	4822 122 40586	CERAMIC 0.1 $\mu$ F $\pm$ 20% 25V
CU06	4822 122 31823	CERAMIC 15PF $\pm$ 5% 50V
CU07	4822 122 31823	CERAMIC 15PF $\pm$ 5% 50V
CU08	4822 124 41604	ELECT 0.1 $\mu$ F 50V
CU09	4822 124 80087	ELECT 220 $\mu$ F 6.3V
CU11	4822 122 40586	CERAMIC 0.01 $\mu$ F $\pm$ 20% 25V
		<b>PU54-RESISTORS</b>
GU01	4822 111 92205	10K $\Omega$ X 4, ARRAY
GU02	4822 111 92204	10K $\Omega$ X 5, ARRAY
GU03	4822 111 92205	10K $\Omega$ X 4, ARRAY
		<b>PU54-RESISTORS (COMMON)</b> CARBON FILM FIXED RESISTOR, $\pm$ 5% 1/6W : RU10, RU14~RU28, RU30
		<b>PU54-SEMICONDUCTORS</b>
QU01	4822 209 33823	U-COM TMP87CK70AF
QU12	4822 130 83519	PHOTO UNIT RPM-670CBR
		<b>PU54-MISCELLANEOUS</b>
SU01 }	4822 276 20508	PUSH SWITCH, TACT
SU18		
VU01	4822 130 91418	DISPLAY UNIT
XU01	4822 242 72066	CERAMIC RESONATOR, CST8.0MHZ
		<b>PV04-MAIN FUNCTION CIRCUIT BOARD</b>
		<b>PV04-CAPACITORS</b>
CA01	4822 125 60185	TRIMMING 20PF
CA02	4822 122 40589	CERAMIC 0.047 $\mu$ F $\pm$ 20% 25V
CA03	4822 126 11553	CERAMIC 15PF $\pm$ 5% 50V
CA04	5322 121 54128	FILM 390PF $\pm$ 5% 50V
CA05	4822 126 10513	CERAMIC 47PF $\pm$ 5% 50V
CA06	4822 122 40586	CERAMIC 0.01 $\mu$ F $\pm$ 20% 25V
CA07	4822 122 40586	CERAMIC 0.01 $\mu$ F $\pm$ 20% 25V
CA08	4822 125 60185	TRIMMING 20PF
CA09	4822 126 11553	CERAMIC 15PF $\pm$ 5% 50V
CA11	4822 122 31349	CERAMIC 68PF $\pm$ 5% 50V
CA12	4822 122 10367	CERAMIC 150PF $\pm$ 5% 50V
CA13	4822 122 40586	CERAMIC 0.01 $\mu$ F $\pm$ 20% 25V
CA18	4822 124 21894	ELECT 10 $\mu$ F 16V
CD01	4822 122 40586	CERAMIC 0.01 $\mu$ F $\pm$ 20% 25V (SR1040)
CD02	4822 122 40586	CERAMIC 0.01 $\mu$ F $\pm$ 20% 25V (SR1040)
CD04	4822 122 40586	CERAMIC 0.01 $\mu$ F $\pm$ 20% 25V
CD05	4822 122 40586	CERAMIC 0.01 $\mu$ F $\pm$ 20% 25V (SR1040)



REF. DESIG.	PART NO.	DESCRIPTION
CD06	4822 122 40586	CERAMIC 0.01 $\mu$ F $\pm$ 20% 25V ( SR1040 )
CD07	4822 122 40586	CERAMIC 0.01 $\mu$ F $\pm$ 20% 25V
CD08	4822 122 40586	CERAMIC 0.01 $\mu$ F $\pm$ 20% 25V
CD09	4822 124 23052	ELECT 100 $\mu$ F 16V
CN01	4822 124 22571	ELECT 10 $\mu$ F 50V
CN02	4822 124 40786	ELECT 2.2 $\mu$ F 50V
CN03	4822 124 23056	ELECT 47 $\mu$ F 16V
CN04	4822 124 23056	ELECT 47 $\mu$ F 16V
CN05	4822 122 40617	CERAMIC 0.1 $\mu$ F +80% -20% 50V
CV05		
}	4822 126 10408	CERAMIC 220PF $\pm$ 10% 25V [ $\varnothing$ 2 ]
CV16		
CV17	4822 122 40617	CERAMIC 0.1 $\mu$ F +80% -20% 50V
CV19	4822 122 40617	CERAMIC 0.1 $\mu$ F +80% -20% 50V
CV21		
}	4822 124 21894	ELECT 10 $\mu$ F 16V
CV26		
CV27	4822 122 40617	CERAMIC 0.1 $\mu$ F +80% -20% 50V
CV28	4822 122 40617	CERAMIC 0.1 $\mu$ F +80% -20% 50V
C201	4822 122 40586	CERAMIC 0.01 $\mu$ F $\pm$ 20% 25V
C202	4822 122 40586	CERAMIC 0.01 $\mu$ F $\pm$ 20% 25V
C203	4822 122 40589	CERAMIC 0.047 $\mu$ F $\pm$ 20% 25V
C204	4822 124 21894	ELECT 10 $\mu$ F 16V
C205	4822 122 40589	CERAMIC 0.047 $\mu$ F $\pm$ 20% 25V
C206	4822 124 21982	ELECT 3.3 $\mu$ F 50V
C207	4822 124 23052	ELECT 100 $\mu$ F 16V
C208	4822 122 40589	CERAMIC 0.047 $\mu$ F $\pm$ 20% 25V
C209	4822 124 23053	ELECT 1 $\mu$ F 50V
C210	5322 122 32072	CERAMIC 33pF $\pm$ 5% 50V
C211	4822 124 23053	ELECT 1 $\mu$ F 50V
C212	4822 124 41604	ELECT 0.1 $\mu$ F 50V
C213	4822 124 23054	ELECT 0.47 $\mu$ F 50V
C214	4822 124 23057	ELECT 10 $\mu$ F 50V
C215	4822 122 40589	CERAMIC 0.047 $\mu$ F $\pm$ 20% 25V
C217	5322 122 32143	CERAMIC 22 $\mu$ F $\pm$ 5% 50V
C218	4822 124 23052	ELECT 100 $\mu$ F 16V
C301	4822 124 21982	ELECT 3.3 $\mu$ F 50V
C302	4822 124 21982	ELECT 3.3 $\mu$ F 50V
C305	4822 124 21982	ELECT 3.3 $\mu$ F 50V
C306	4822 124 21982	ELECT 3.3 $\mu$ F 50V
C307	4822 124 21894	ELECT 100 $\mu$ F 16V
C308	4822 124 21894	ELECT 100 $\mu$ F 16V
C501	4822 126 10513	CERAMIC 47PF $\pm$ 5% 25V
C502	4822 126 10513	CERAMIC 47PF $\pm$ 5% 25V
C503	4822 124 23052	ELECT 100 $\mu$ F 16V
C504	4822 122 40586	CERAMIC 0.01 $\mu$ F $\pm$ 20% 25V
C505	4822 124 23053	ELECT 1 $\mu$ F 50V
C506	4822 124 41604	ELECT 0.1 $\mu$ F 50V
C507	4822 122 40586	CERAMIC 0.01 $\mu$ F $\pm$ 20% 25V
C508	4822 124 23052	ELECT 100 $\mu$ F 16V
C509	5322 122 32265	CERAMIC 100PF $\pm$ 5% SL 500V
C510	5322 122 32265	CERAMIC 100PF $\pm$ 5% SL 500V
C511	4822 122 40586	CERAMIC 0.01 $\mu$ F $\pm$ 20% 25V
C512	4822 122 40586	CERAMIC 0.01 $\mu$ F $\pm$ 20% 25V
C701	4822 124 23057	ELECT 4.7 $\mu$ F 50V
C702	4822 124 23057	ELECT 4.7 $\mu$ F 50V
C705	5322 122 32072	CERAMIC 33pF $\pm$ 5% 50V
C706	5322 122 32072	CERAMIC 33pF $\pm$ 5% 50V

REF. DESIG.	PART NO.	DESCRIPTION
C707	4822 124 22571	ELECT 10 $\mu$ F 50V
C708	4822 124 22571	ELECT 10 $\mu$ F 50V
C711	4822 126 10797	CERAMIC 10PF 500V
C712	4822 126 10797	CERAMIC 10PF 500V
C713	4822 122 40103	CERAMIC 5PF $\pm$ 0.25PF 50V
C714	4822 122 40103	CERAMIC 5PF $\pm$ 0.25PF 50V
C717		
}	5322 122 32265	CERAMIC 100PF $\pm$ 5% 500V
C720		
C721		
}	4822 124 21895	ELECT 0.22 $\mu$ F 50V
C724		
C725	4822 124 23052	ELECT 100 $\mu$ F 16V
C726	4822 124 22571	ELECT 10 $\mu$ F 50V
C735	4822 122 30043	CERAMIC 0.01 $\mu$ F +80% -20% 50V [ $\varnothing$ 2 ]
C801	4822 122 40589	CERAMIC 0.047 $\mu$ F $\pm$ 20% 25V
C802	4822 122 40589	CERAMIC 0.047 $\mu$ F $\pm$ 20% 25V
C803	4822 124 22695	ELECT 2200 $\mu$ F 35V
C805	4822 124 21894	ELECT 10 $\mu$ F 50V
C806	4822 124 23057	ELECT 4.7 $\mu$ F 50V
C807	4822 124 21894	ELECT 10 $\mu$ F 50V
C808	4822 124 23056	ELECT 47 $\mu$ F 16V
C809	4822 124 22571	ELECT 10 $\mu$ F 50V
▲C811	4822 126 12453	CERAMIC 0.01 $\mu$ F +80%-20%500V
▲C812	4822 126 12866	ELECT 4700 $\mu$ F 50V
▲C813	4822 126 12866	ELECT 4700 $\mu$ F 50V
C814	4822 122 40589	CERAMIC 0.047 $\mu$ F $\pm$ 20 25V
C815	4822 122 40589	CERAMIC 0.047 $\mu$ F $\pm$ 20% 25V
C816	4822 124 22571	ELECT 10 $\mu$ F 50V
C***		HIGH DIELECTRIC CONSTANT CERAMIC CAPACITOR, $\pm$ 10% 50V: ( CV01~CV04, CV29, CV30 [ $\varnothing$ 2 ] ), C703, C704, C709, C710
C***		PLASTIC FILM CAPACITOR $\pm$ 5% 50V : CA15, CA16, CA17, C303, C304, ( C309, C310 [ $\varnothing$ 1 ] )
C***		ELECTROLYTIC CAPACITOR, $\pm$ 20% : C727, C728, C804, C817
RA11	4822 100 11351	<b>PV04-RESISTORS</b> 10K $\Omega$ TRIMMING
▲RN19	4822 053 11271	270 $\Omega$ $\pm$ 5% 2W
▲RN20	4822 053 11222	2.2K $\Omega$ $\pm$ 5% 2W
▲RN22	4822 053 11271	270 $\Omega$ $\pm$ 5% 2W
▲RV37	4822 052 10151	150 $\Omega$ $\pm$ 5% 1/6W
▲RV38	4822 052 10151	150 $\Omega$ $\pm$ 5% 1/6W
▲R103	4822 052 10109	10 $\Omega$ $\pm$ 5% 1/6W
▲R207	4822 052 10101	100 $\Omega$ $\pm$ 5% 1/6W
R211	4822 100 11373	4.7K $\Omega$ TRIMMING
R212	4822 100 11352	22K $\Omega$ TRIMMING
▲R313	4822 052 10151	150 $\Omega$ $\pm$ 5% 1/6W
▲R314	4822 052 10151	150 $\Omega$ $\pm$ 5% 1/6W



REF. DESIG.	PART NO.	DESCRIPTION
▲R512	4822 052 10221	220 Ω ±5% 1/6W
▲R713	4822 050 26809	68 Ω ±5% 1/6W
▲R714	4822 050 26809	68 Ω ±5% 1/6W
R719	4822 100 11386	1K Ω TRIMMING
R720	4822 100 11386	1K Ω TRIMMING
▲R725	?	68 Ω ±5% 1/6W
▲R730	4822 050 26809	68 Ω ±5% 1/6W
▲R731	4822 053 10221	220 Ω ±5% 1W
▲R732	4822 053 10221	220 Ω ±5% 1W
▲R733	?	10 Ω ±5% 1/6W
▲R736	4822 116 82049	0.18 Ω X 2 3W
▲R737	4822 116 82049	0.18 Ω X 2 3W
▲R738	4822 116 82049	0.18 Ω X 2 3W
▲R739	4822 050 26809	68 Ω ±5% 1/6W
▲R740	4822 050 26809	68 Ω ±5% 1/6W
▲R743	4822 053 11109	10 Ω ±5% 2W
▲R744	4822 053 11109	10 Ω ±5% 2W
▲R745	4822 116 60263	3.3K Ω ±5% 1W
▲R747	4822 052 10221	220 Ω ±5% 1/6W
▲R748	4822 052 10221	220 Ω ±5% 1/6W
▲R751	4822 053 10331	330 Ω ±5% 1W
▲R752	4822 053 10331	330 Ω ±5% 1W
▲R801	4822 117 10158	1 Ω ±5% 1/4W
▲R802	4822 117 10158	1 Ω ±5% 1/4W
▲R808	4822 117 10002	2.2K Ω ±5% 1/2W
▲R809	4822 053 10221	220 Ω ±5% 1W
▲R810	4822 053 11688	6.8 Ω ±5% 2W
R***		<b>PV04-RESISTORS ( COMMON )</b> CARBON FILM FIXED RESISTOR, ±5% 1/6W : RA01~RA04, RA06~RA10, ( RD01, RD02 [ SR1040 ] ) RD03, RD04, RN01~RN18, RN21, RN31, RN32, RV01~RV36, RV41, RV42, RV45, RV46, R202~R206, R208~R210, R215~R217, R301, R302, R305~R312, R501~R504, R506, R507, R508 [ /01 ], R509~R511, R703~R712, R715~R718, R721~R724, R746, R753, R804~R806
DA01	4822 125 50416	VARICAP SVC342-K
DA02	4822 130 33697	DIODE 1SS135
DA03	4822 125 50416	VARICAP SVC342-K
DA04	4822 130 33697	DIODE 1SS135
DA05	4822 130 33305	DIODE 1SS176, MA165, 1SS254
DA06	4822 130 33305	DIODE 1SS176, MA165, 1SS254
DD01	4822 130 82609	ZENER DIODE MTZJ2.0B (SR1040)
DD02	4822 130 33759	ZENER DIODE 4.7V
DN01	4822 130 80837	DIODE HSS81
DN02	4822 130 80837	DIODE HSS81
DN04	4822 130 32508	DIODE RL103E / DSF10C
DN05	4822 130 33305	DIODE 1SS176, MA165, 1SS254
D501	4822 130 80317	ZENER DIODE 5.1V
D701	4822 130 80273	ZENER DIODE 8.2V
D702	4822 130 80322	ZENER DIODE 15V

REF. DESIG.	PART NO.	DESCRIPTION
D703	?	
?	4822 130 33305	DIODE 1SS176, MA165, 1SS254
D706	?	
▲D801	?	DIODE RL103E / DSF10C
?	4822 130 32508	DIODE RL103E / DSF10C
▲D806	?	
▲D807	4822 130 80838	ZENER DIODE 18V
▲D808	4822 130 32508	DIODE RL103E / DSF10C
▲D809	4822 130 80091	ZENER DIODE 12V
▲D810	4822 130 32508	DIODE RL103E / DSF10C
▲D811	4822 130 31007	DIODE S4VB20
QA01	4822 130 42298	TRANSISTOR 2SC536SP, 2SC2458, 2SC3311, 2SC1740S
QA02	4822 130 42298	TRANSISTOR 2SC536SP, 2SC2458, 2SC3311, 2SC1740S
QA03	4822 130 61892	TRANSISTOR 2SD2144S ( U, V )
QA04	4822 130 42682	DIGITAL TRANSISTOR DTA144ES/ UN4113
QA05	4822 130 42682	DIGITAL TRANSISTOR DTA144ES/ UN4113
QD01	4822 209 30193	IC LB1641
QD02	4822 209 30193	IC LB1641
QN01	4822 130 43233	TRANSISTOR 2SC2240
QN02	4822 130 43233	TRANSISTOR 2SC2240
QN03	4822 130 42951	TRANSISTOR 2SA970
QN04	4822 209 83312	IC TA7317P
QN05	4822 130 60588	DIGITAL TRANSISTOR DTC114ES/ UN4211
QV01	4822 209 72748	IC LC7821
QV03	4822 130 60588	DIGITAL TRANSISTOR DTC114ES/ UN4211
QV04	4822 130 60766	DIGITAL TRANSISTOR DTA114ES/ UN4111
QV05	4822 130 61892	TRANSISTOR 2SD2144S ( U, V )
QV06	4822 130 61892	TRANSISTOR 2SD2144S ( U, V )
QV07	4822 209 83631	IC NJM4558D-D
Q201	4822 209 31001	IC LA1851N
Q202	4822 130 62294	TRANSISTOR 2C1809S ( P )
Q203	4822 130 42682	DIGITAL TRANSISTOR DTA144ES/ UN4113
Q204	4822 130 60766	DIGITAL TRANSISTOR DTA114ES/ UN4111
Q205	4822 126 90006	POSISTOR PTH59F04BH222TS
Q206	4822 130 42298	TRANSISTOR 2SC536SP, 2SC2458, 2SC3311, 2SC1740S
Q301	4822 209 83631	IC NJM4558D-D
Q501	4822 209 30178	IC LC7218
Q502	4822 130 42121	F.E.T. 2SK30A ( Y )
Q503	4822 130 42298	TRANSISTOR 2SC536SP, 2SC2458, 2SC3311, 2SC1740S
Q701	4822 130 42951	TRANSISTOR 2SA970 ( GR, BL )
Q702	4822 130 42951	TRANSISTOR 2SA970 ( GR, BL )
Q703	4822 130 43233	TRANSISTOR 2SC2240
Q704	4822 130 43233	TRANSISTOR 2SC2240
▲Q705	4822 130 60117	TRANSISTOR 2SC3419 ( Y )
▲Q706	4822 130 60117	TRANSISTOR 2SC3419 ( Y )
▲Q707	4822 130 62335	TRANSISTOR 2SD2033 ( E )
▲Q708	4822 130 62335	TRANSISTOR 2SD2033 ( E )
▲Q709	4822 130 62334	TRANSISTOR 2SB1353 ( E )
▲Q710	4822 130 62334	TRANSISTOR 2SB1353 ( E )



REF. DESIG.	PART NO.	DESCRIPTION
▲Q711	4822 130 60697	TRANSISTOR 2SC3180N ( R, O )
▲Q712	4822 130 60697	TRANSISTOR 2SC3180N ( R, O )
▲Q713	4822 130 60694	TRANSISTOR 2SA1263N ( R, O )
▲Q714	4822 130 60694	TRANSISTOR 2SA1263N ( R, O )
▲Q717	4822 209 83732	IC AN7062
▲Q801	4822 209 60826	IC NJM7812FA
▲Q802	4822 209 32514	IC L78MR06
<b>PV04-MISCELLANEOUS</b>		
A101	4822 210 10568	V.H.F. TUNER, FRONT END [ /01 ]
A101	4822 210 10567	V.H.F. TUNER, FRONT END [ /02 ]
FA01	4822 242 81262	CERAMIC FILTER SFP450F
F201	4822 242 70665	CERAMIC FILTER SFE10.7MS3-A
F202	4822 242 70665	CERAMIC FILTER SFE10.7MS3-A
JV01	4822 267 31451	TERMINAL 8P
JV02	4822 267 31451	TERMINAL 8P
JV03	4822 267 41009	TERMINAL 2P
JV04		JACK, CARD FIT 27P
J101	4822 290 81632	TERMINAL ANTENNA
LA01	4822 157 63084	ANT COIL MW
LA02	4822 157 70779	OSC COIL MW
LA03	4822 157 52714	ANT COIL LW
LA04	4822 157 70781	OSC COIL LW
LA05	4822 157 53589	CHOKE COIL 39mH
LA06	4822 148 81095	I.F.T. COIL AM
LN02	4822 280 20469	RELAY SVR-24A
L201	4822 157 63904	I.F.T. COIL FM DET
L202	4822 156 10794	M.P.X. COIL [ /02 ]
L301	4822 157 70021	M.P.X. COIL 19.38KHz
L302	4822 157 70021	M.P.X. COIL 19.38KHz
L701	4822 157 70022	SPEAKER CHOKE COIL
L702	4822 157 70022	SPEAKER CHOKE COIL
SV01	4822 277 21718	SLIDE SWITCH SYSTEM /INT/EXT
S301	4822 277 21712	SLIDE SWITCH SCAN STEP [ /01 ]
WV01		JAMPER LEAD, SUM-CARD 27P
X201	4822 242 81608	CERAMIC RESONATOR, CSB456F33
X501	4822 242 72333	CRYSTAL 7.2MHZ
<b>PV64-SPEAKER TERMINAL CIRCUIT BOARD</b>		
C729	4822 122 30043	CERAMIC CAP. 0.01 $\mu$ F +80% -20% 50V [ /02 ]
C730	4822 122 30043	CERAMIC CAP. 0.01 $\mu$ F +80% -20% 50V [ /02 ]
C733	4822 122 30043	CERAMIC CAP. 0.01 $\mu$ F +80% -20% 50V [ /02 ]
C734	4822 122 30043	CERAMIC CAP. 0.01 $\mu$ F +80% -20% 50V [ /02 ]
DN03	4822 130 32508	DIODE RL103E / DSF10C
J701	4822 290 81646	TERMINALL 4P SPEAKER
▲LN01	4822 280 70354	RELAY VB24MBU

**NOTE ON SAFETY:**

**Symbol ▲** Fire or electrical shock hazard. Only original parts should be used to replace any part marked with symbol ▲. Any other component substitution (other than original type), may increase risk of fire or electrical shock hazard.