



# SERVICE MANUAL

**marantz**®

model SR1100L

*Stereophonic Receiver*

## MARANTZ DESIGN AND SERVICE

Using superior design and selected high grade components, MARANTZ has created the ultimate in stereo sound. Only original MARANTZ parts can insure that your MARANTZ product will continue to perform to the specifications for which it is famous.

Parts for your MARANTZ stereo are generally available within 72 hours throughout the nation via a toll-free line to our National Parts Depot in California. The sales professionals who take your call immediately refer to their own desk top computer terminal and can quickly determine the availability and price information you require. If for some reason, your order should exceed our available stock, we usually can instantly provide an alternate replacement part or current delivery information. When the order is placed and confirmed, the computer simultaneously generates "hard copy" orders at the distribution center. As hard copies come directly from the computer to the national parts depot, your requested stock is assembled and prepared for shipment and placed on the first available carrier for delivery to you.

### ORDERING PARTS

Phone orders will eliminate mail delays, and we encourage the use of this method. If you order by mail, use MARANTZ parts order forms which are available from our National Parts Depot located at the following address:

The following information must be supplied to eliminate delays in processing your order:

1. Complete address.
2. Complete part numbers.
3. Complete description of parts.
4. Model number for which part is required (indicate MARANTZ).
5. Account number (for account customers only).

Direct consumers will be provided with the current retail price quotation on available parts in order to advise them of the cost of the parts and shipping.

### OVERSEAS PARTS ORDERING

Parts may also be ordered from the following overseas addresses:

**Marantz Australia**  
32 Cross Street  
Brookvale, N.S.W. 2100  
Australia

**Marantz Germany Gmbh**  
Max-Planck-Straße 22,  
D-6072 Dreieich  
West Germany

**Marantz Audio U.K., Ltd.**  
193, London Road  
STAINES, Middlesex  
United Kingdom

**Marantz Svenska A.B.**  
Franzengatan 6  
10425 Stockholm  
Sweden

**Marantz Europe, S.A.**  
326, Avenue Louise  
Boîte 32  
1050 Brussels  
Belgium

**Marantz Belgium**  
45 Rue Auguste Van Zande  
1080 Brussels  
Belgium

**Marantz France**  
4 Rue Bernard Palissy  
92600 Asnieres  
France

**Marantz Norske A.S.**  
Refstadalleen 13  
Oslo 5  
Norway

All of the above locations are fully equipped to take care of your total service needs. Because various countries have differing configuration requirements, it is necessary that you contact the service facility in your particular country. In the event that there is no service location listed for your country, please contact the nearest facility for the necessary assistance.

**marantz®**

## TABLE OF CONTENTS

1.	P.W. BOARDS .....	1
2.	TEST EQUIPMENT REQUIRED FOR SERVICING .....	1
3.	ALIGNMENT PROCEDURES .....	3
4.	VOLTAGE CONVERSION .....	5
5.	DIAGRAM AND COMPONENT LOCATIONS .....	6
5.1	Main Amp. & Power Supply (P700) Schematic Diagram and Component Locations .....	6
5.2	Antenna/OSC (PB00) Schematic Diagram and Component Locations .....	6
5.3	Signal & Tuning LED (PX00) Schematic Diagram and Component Locations .....	8
5.4	Tuner (P100) Schematic Diagram and Component Locations .....	8
5.5	Switch Assembly (PS00) Diagram and Component Locations .....	10
5.6	Speaker Terminal (PT00) Diagram and Component Locations .....	10
5.7	Power Switch (PU00) Diagram and Component Locations .....	10
6.	BLOCK DIAGRAM .....	12
7.	EXPLODED VIEWS AND PARTS LIST .....	13
8.	TECHNICAL SPECIFICATIONS .....	24
9.	SCHEMATIC DIAGRAM .....	26

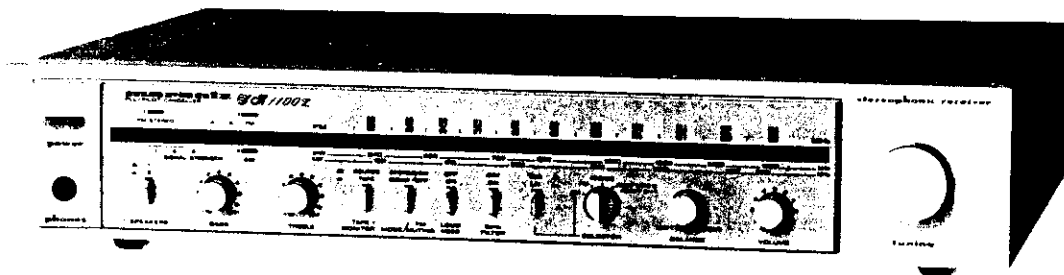

## INTRODUCTION

This service manual was prepared for use by Authorized Warranty Stations and contains service information for Marantz Model SR1100L Stereophonic Receiver.

Servicing information and voltage data included in this manual are intended for use by the knowledgeable and experienced technician only. All instructions should be read carefully. No attempt should be made to proceed without a good understanding of the operation of the receiver.

The parts list furnishes information by which replacement parts may be ordered from the Marantz Company. A simple description is included for parts which can usually be obtained through local suppliers.

## 1. P.W. BOARDS

As can be seen from the circuit diagram the chassis of Model SR1100L consists of the following units. Each unit mounted on a printed circuit board is described within the square enclosed by a bold dotted line on the circuit diagram.

1. Tuner . . . . . mounted on P.W. Board P100
2. Main Amp/Power Supply  
. . . . . mounted on P.W. Board P700
3. Volume/Balance Push Switch  
. . . . . mounted on P.W. Board PS00
4. Speaker Terminal . . . . . mounted on P.W. Board PT00
5. Tuning LED . . . . . mounted on P.W. Board PX00
6. Antenna Coil . . . . . mounted on P.W. Board PB00
7. Power Switch . . . . . mounted on P.W. Board PU00

## 2. TEST EQUIPMENT REQUIRED FOR SERVICING

This table lists the test equipment required for servicing the Model SR1100L Receiver.

Item	Manufacturer and Model No.	Use
AM Signal Generator		Signal source for AM alignment
Test Loop		Use with AM Signal Generator
FM Signal Generator MPX Signal Generator	Sound Technology Model 1000A	Signal source for FM alignment Stereo separation alignment and trouble shooting
Distortion Analyzer Audio Oscillator AC VTVM	Sound Technology Model 1700A	Distortion measurements Sinewave and squarewave signal source Voltage measurements (AC)
Oscilloscope	Tektronix Model T932 Philips Model 3232	Waveform analysis and trouble shooting and ASO alignment
Frequency Counter	Fluke Model 1900A	MPX Oscillator adjustment (VCO)
Circuit Tester		Trouble shooting
DC VTVM	Fluke Model 8000 "Digital" Simpson Model 313, Triplet Model 801	Voltage measurements (DC)
AC Wattmeter	Simpson Model 1379	Monitors primary power to amplifier
AC Ammeter	Commercial Grade (1-10A)	Monitors amplifier output under short circuit condition
Line Voltmeter	Simpson Model 1359	Monitors potential of primary power to amplifier
Variable Autotransformer	Superior Electronic Co., Powerstat Model 116B-10A	Adjusts level of primary power to amplifier
Shorting Plug	Use phono plug with 600-ohm across center pin and shell	Shorts amplifier input to eliminate noise pickup
Output Load (8 ohms, ±0.5%, 100W)	Commercial Grade	Provides 8-ohm load for amplifier output termination
Output Load (4 ohms, ±0.5%, 100W)	Commercial Grade	Provides 4-ohm load for amplifier output termination

X

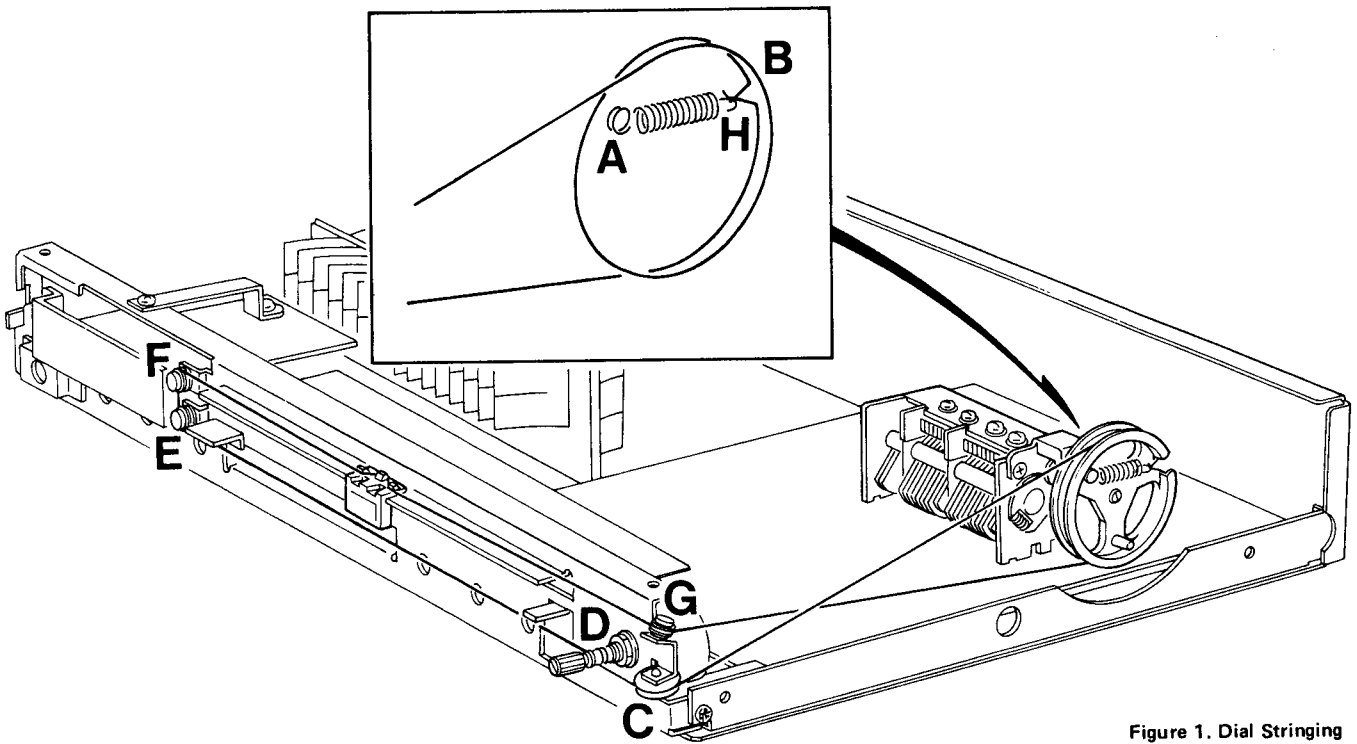

Figure 1. Dial Stringing

### SR1100L TUNER P.W. BOARD

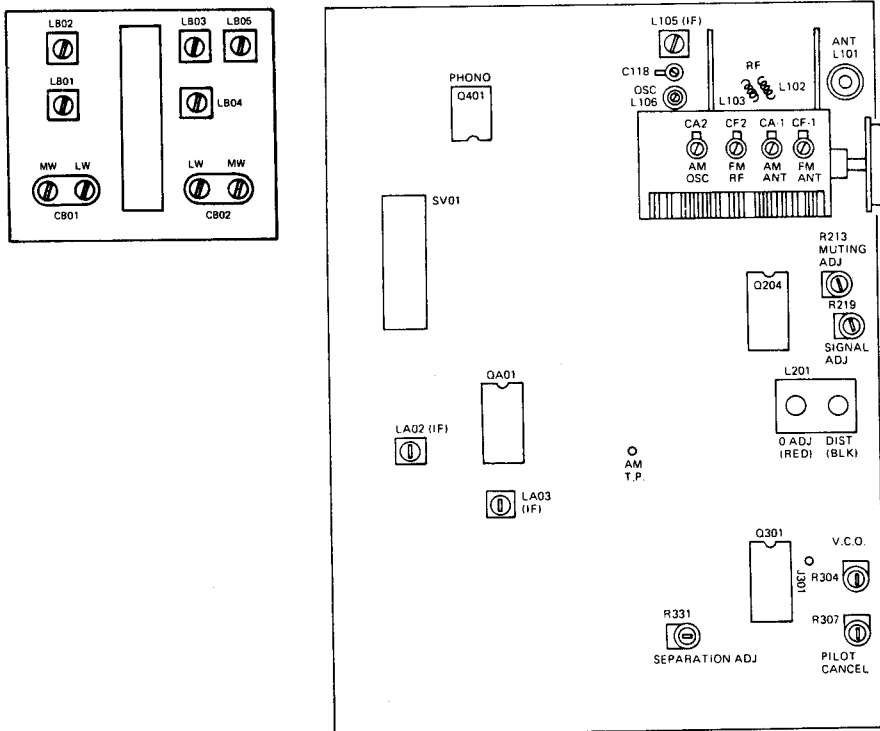

Figure 2. Adjustment Point Locations

### 3. ALIGNMENT PROCEDURES

A dummy resistor of 47 k-ohms must be connected across the tuner output terminals before alignment.

#### 3.1 FM Alignment Procedures (Function switch in the "FM" position) FM RF Alignment

Step	Signal Source Connection	Signal Frequency	Indicator Connection	Set the Digital Readout Frequency	Adjust
1	RF generator to FM antenna terminals through matching network (300 ohms, balanced) (Maintain RF level below limit.)	87.4 MHz	VTVM to L or R channel output	Tuning capacitor minimum closed.	L106 for maximum output.
2		108.2 MHz		Tuning capacitor maximum open.	C118 for maximum output.
3		90 MHz		90 MHz	L101, L103 for maximum output.
4		106 MHz		106 MHz	ANT. RF. TRIM. CAP. for maximum output.
5	Repeat steps 1 to 4.				
6	Check overall response curve and repeat above steps as necessary to obtain maximum sensitivity.				
7	No connection	No signal	"0" center meter or DC current meter in 100 $\mu$ A range between J201 and J202		L201 primary core so that the meter indicates its center or may read "0". (RED core)
8	RF generator 1 mV (or 300 $\mu$ V, only Step 10) output to FM antenna terminals through matching network. (300 ohms, balanced)	98 MHz	Distortion meter to L or R channel output	98 MHz	L201 Secondary core (BLK) for minimum distortion.
9					
10		98 MHz		98 MHz	R219 so that signal strength LED may light 5 points.

#### 3.2 Muting Circuit Alignment

Step	Signal Source Connection	Signal Frequency	Indicator Connection	Set the Digital Readout Frequency	Adjust
1	RF generator 12.5 $\mu$ V output to FM antenna terminals through matching network (300 ohms, balanced)	98 MHz	VTVM to R or L channel output	98 MHz	R213 for 12.5 $\mu$ V threshold level. (During this adjustment turn the muting pushswitch "ON".)

#### 3.3 Multiplex Alignment Procedures (Function switch in the "FM" position/Mode switch in the "STEREO" position)

Step	Signal Source Connection	Signal Frequency	Indicator Connection	Set the Digital Readout Frequency	Adjust
1	RF generator to FM antenna terminals through matching network (300 ohms, balanced), with 1 mV FM stereo simulator RF level and 100% modulation (pilot 9%)	No Modulation	Frequency counter to J301	98 MHz	R304 so that Frequency counter may precisely read 76 kHz.
2		Stereo, left (1,000 Hz)	VTVM to right channel output		R331 for maximum output and same separation in both channels.
3		Stereo, right (1,000 Hz)	VTVM to left channel output		
4		Pilot only	VTVM to R or L output	98 MHz	R307 for minimum output and same output in both channels.

### 3.4 AM Alignment Procedures (Function switch in the "AM" position)

#### 1. AM IF Alignment

Step	Signal Source Connection	Signal Frequency	Indicator Connection	Set Dial Pointer to:	Adjust
1	Sweep generator to OSC Variable Cap.	450 kHz marker	Oscilloscope to T.P.	Quiet point on band	LA02 & LA03 for maximum and symmetric response.

#### 2. MW RF Alignment

Step	Signal Source Connection	Signal Frequency	Indicator Connection	Set the Digital Readout Frequency	Adjust
1	Apply the signal to the AM bar antenna from the RF generator, using the test loop, as per the Figure 2.	520 kHz	VTVM to L or R channel output	Tuning capacitor minimum closed.	LB04 for maximum output.
2		1,630 kHz		Tuning capacitor maximum open.	CB02 for maximum output.
3		600 kHz		600 kHz	LB01 for maximum output.
4		1,400 kHz		1,400 kHz	CB01 for maximum output.
5	Repeat steps 1 to 4 as necessary to obtain maximum sensitivity.				

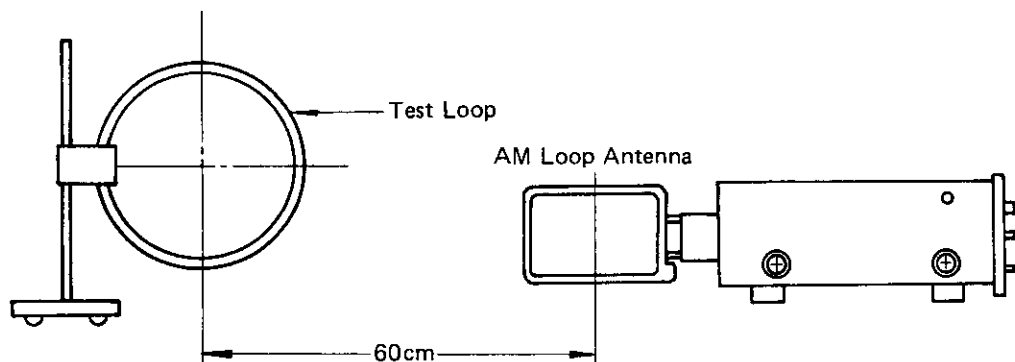

Figure 3. Application of AM Signal

#### 3. LW RF Alignment

Step	Signal Source Connection	Signal Frequency	Indicator Connection	Set Dial Pointer to	Adjust
1	RF generator to AM antenna terminals through IHF dummy	145 kHz	VTVM to L or R channel	145 kHz with tuning gang closed.	LB03 for maximum output.
2		380 kHz		380 kHz with tuning gang open.	CB02 for maximum output.
3		170 kHz		170 kHz	LB02 for maximum output.
4		350 kHz		350 kHz	CB01 for maximum output.
5		450 kHz		Tuning gang closed.	LB05 for minimum output.
6	Repeat steps 1 to 4 as necessary to obtain maximum sensitivity.				

## 4. VOLTAGE CONVERSION

To convert the unit to a different power source voltage, change the position as illustrated in the drawing below.

**CAUTION: DISCONNECT POWER SUPPLY CORD FROM AC OUTLET BEFORE CONVERTING VOLTAGE. DO NOT DISASSEMBLE THE VOLTAGE SELECTOR ABSOLUTELY.**

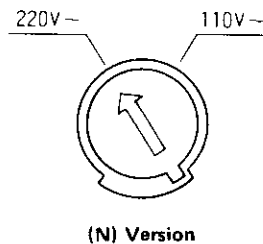
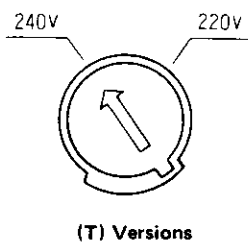
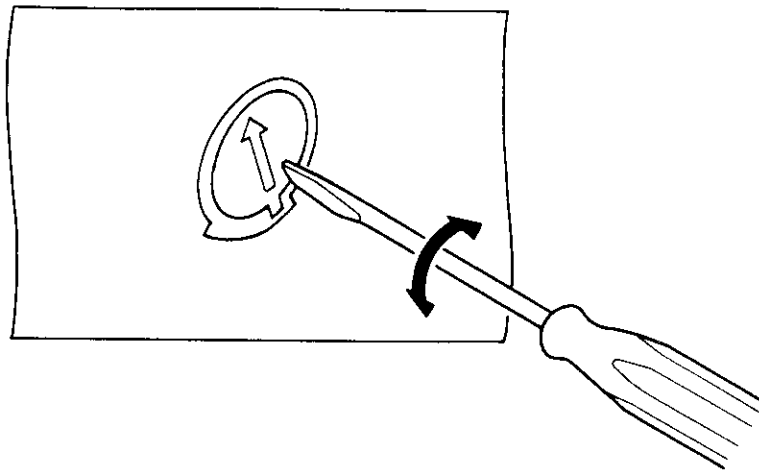



Figure 3. Voltage Conversion

(Note on safety: The parts marked with  are important parts on the safety. Please use the parts having the designated parts numbers without fail.)

### FTZ REGULATION

Instruction for the use in the range other than specified in FTZ codes.

**Achtung für die Leute, die in dem Gebiet wohnen, wo die FTZ-Bestimmungen vorherrschend sind.**

Sollte das Gerät auch für Frequenzen ausserhalb des in den FTZ-Bestimmungen angegebenen Bereiches empfangebereit sein, bitten wir, den Bereich durch Nachstellen des Kernes in der Oszillatordspule (in der Abbildung mit "FTZ" gekennzeichnet) so zu korrigieren, dass er den Bestimmungen entspricht.



## 5. DIAGRAM AND COMPONENT LOCATIONS

### 5.1 Main Amp. & Power Supply (P700) Schematic Diagram and Component Locations

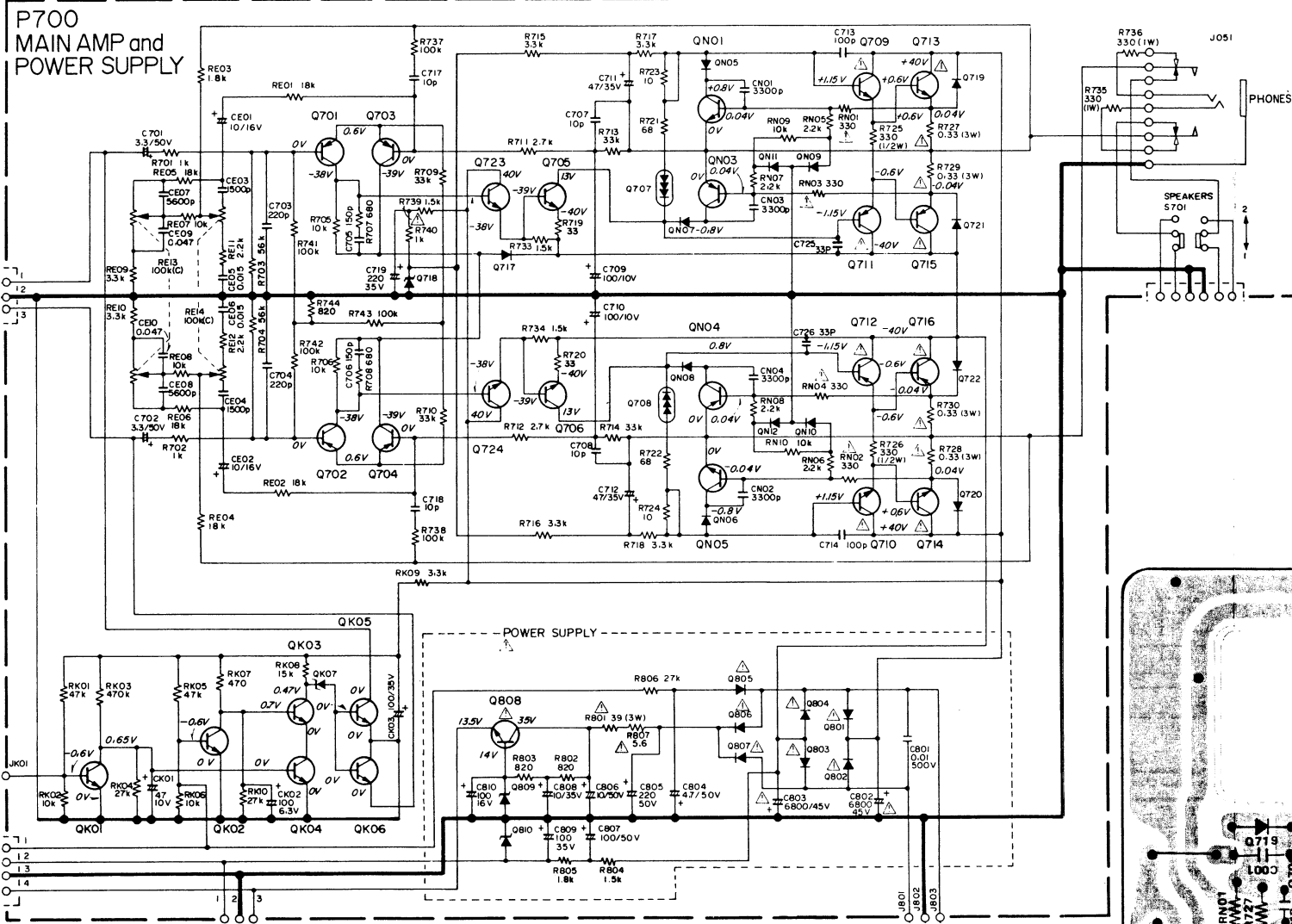

### 5.2 Antenna/OSC (PB00) Schematic Diagram and Component Locations

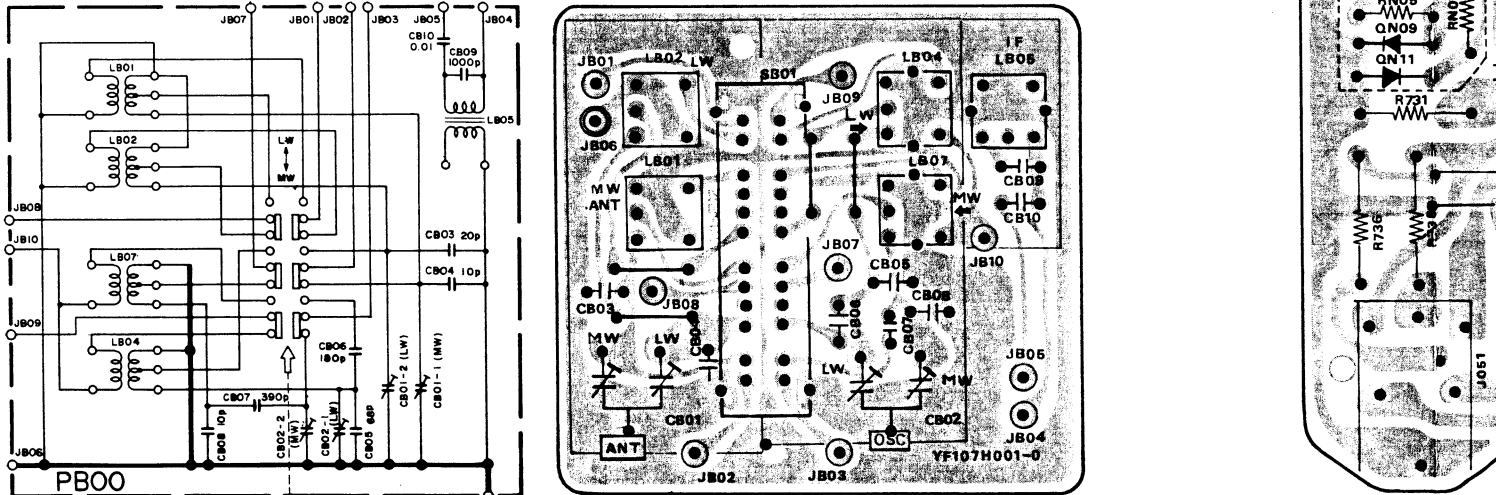

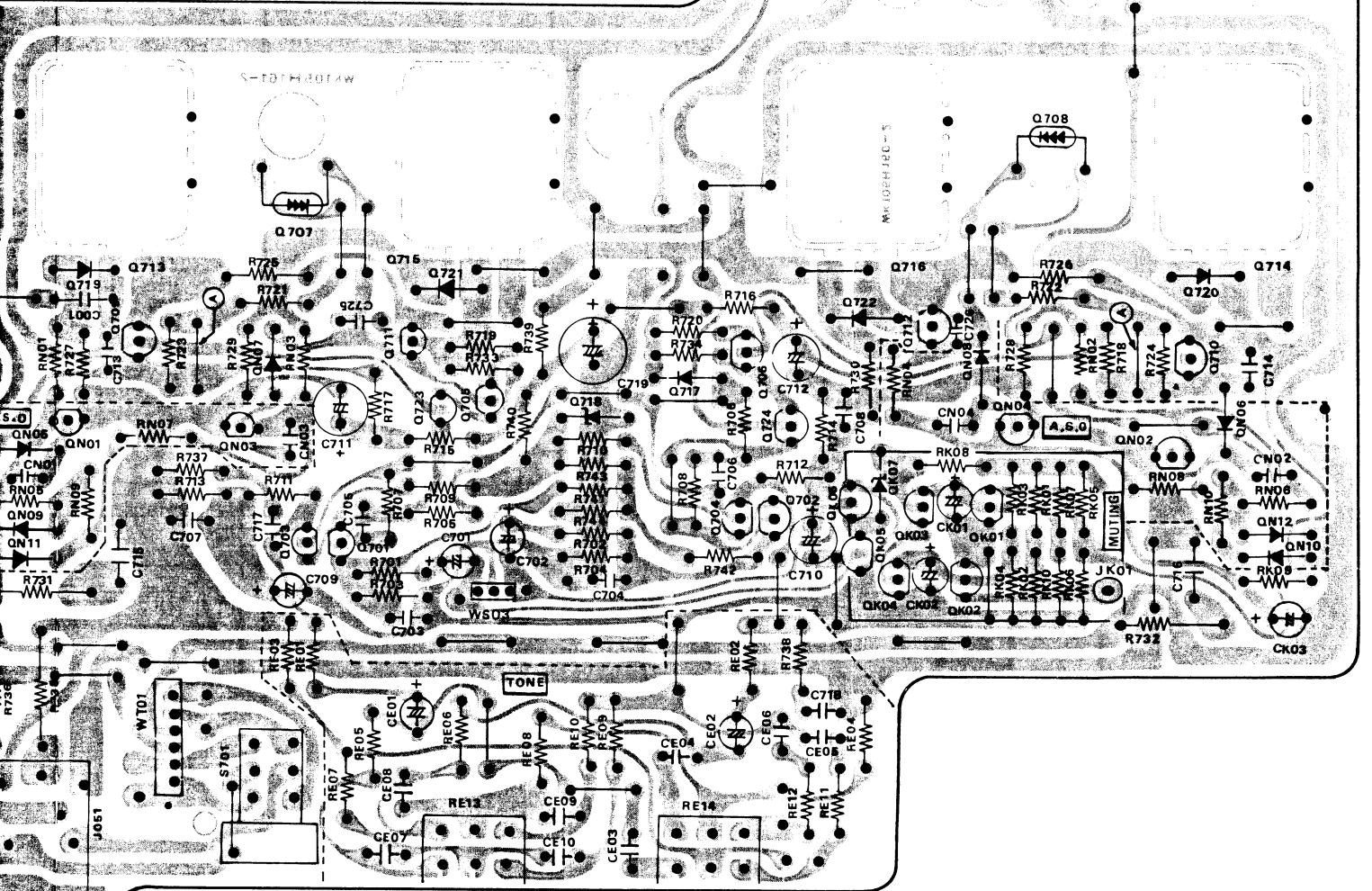
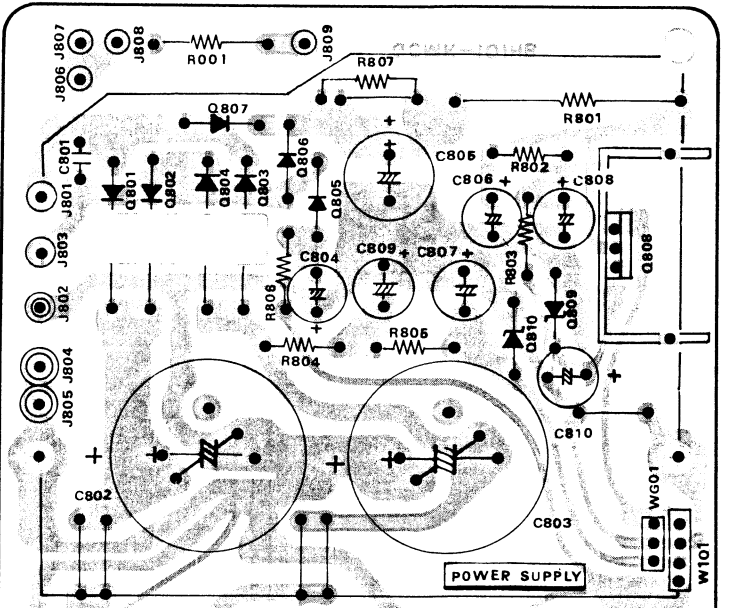
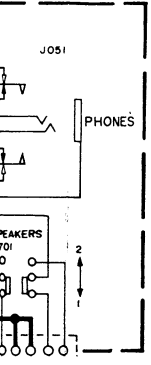

X

### 5.3 Signal & Tuning LED (PX00) Schematic Diagram and Component Locations

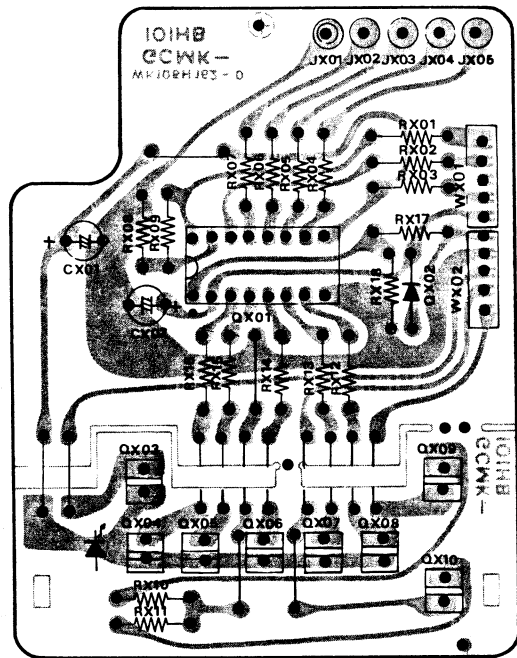
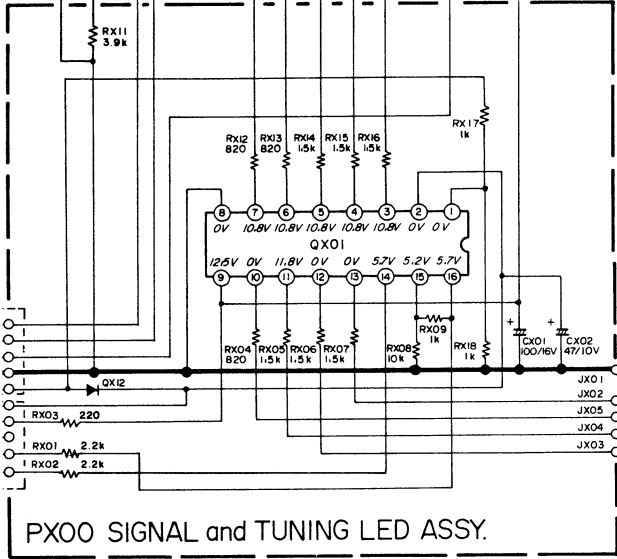

### 5.4 Tuner (PI00) Schematic Diagram and Component Locations

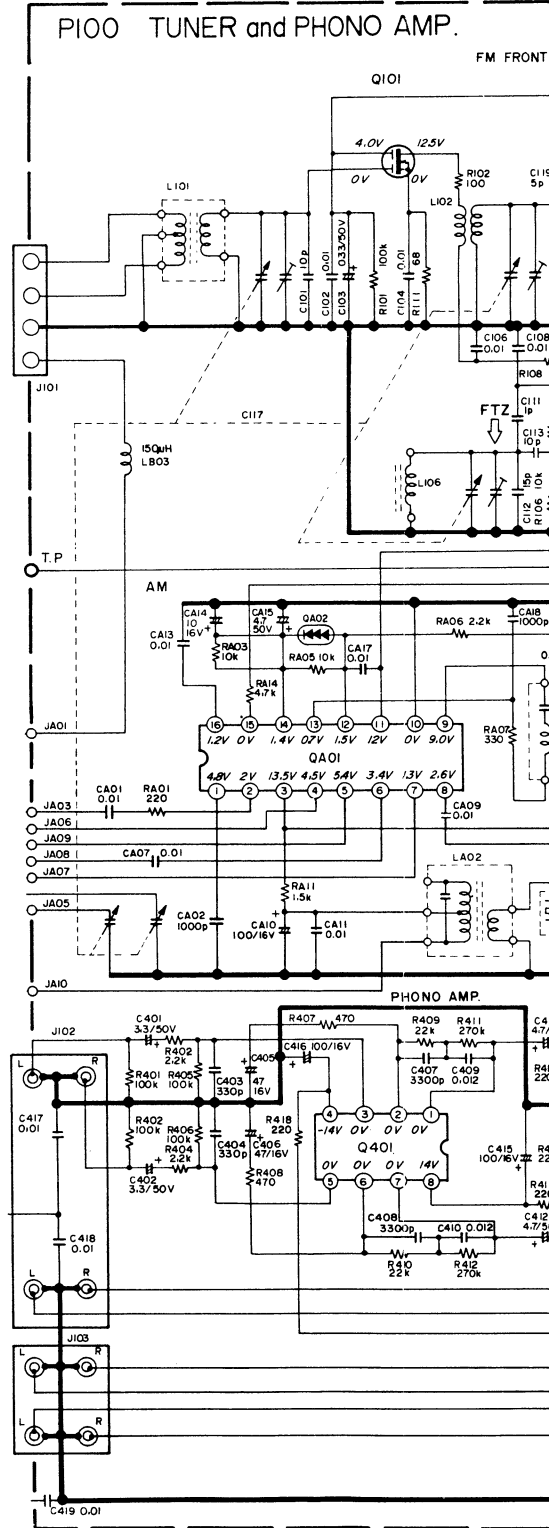

# 00) Schematic Diagram and Component Locations

NER and PHONO AMP.

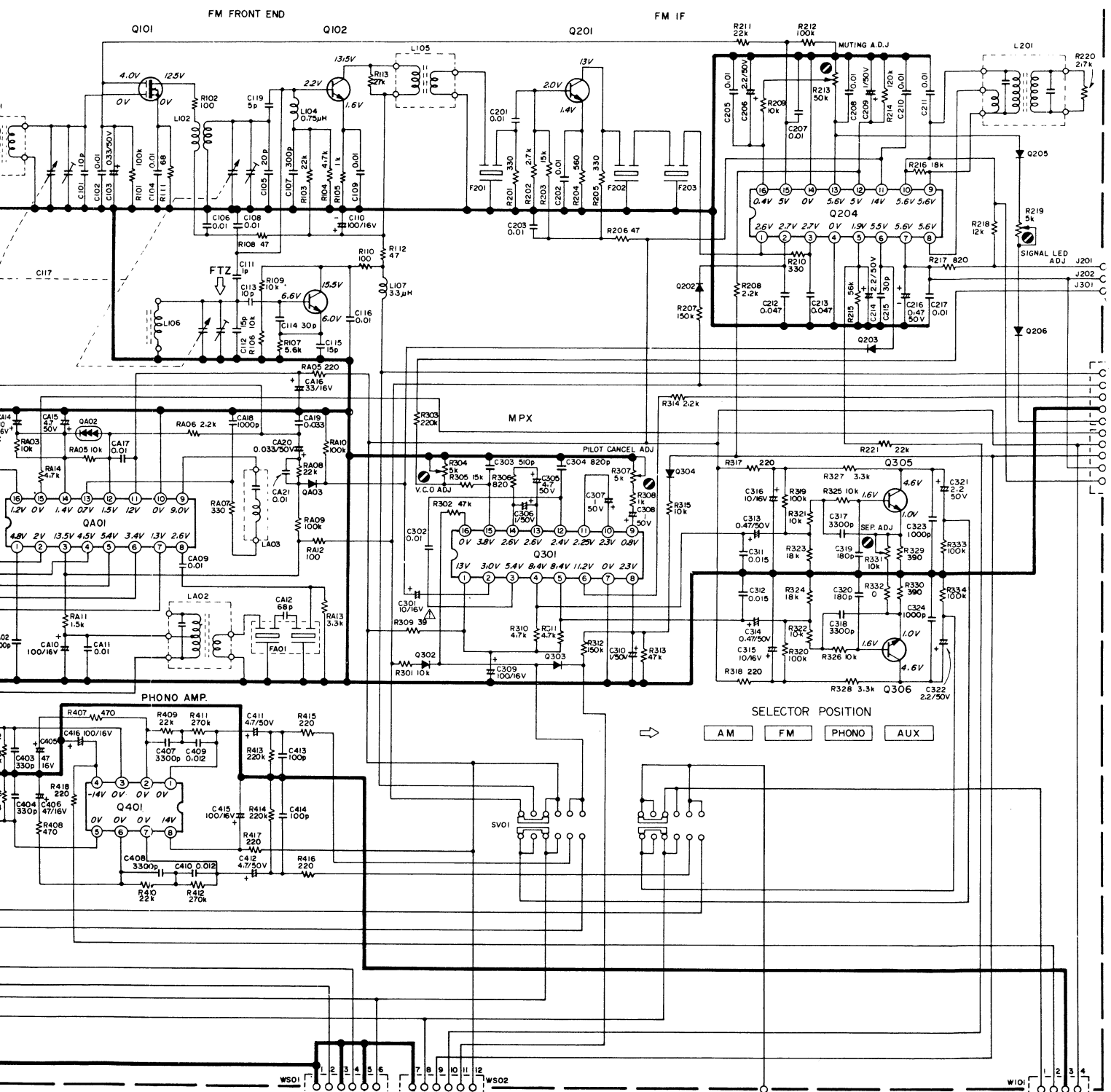

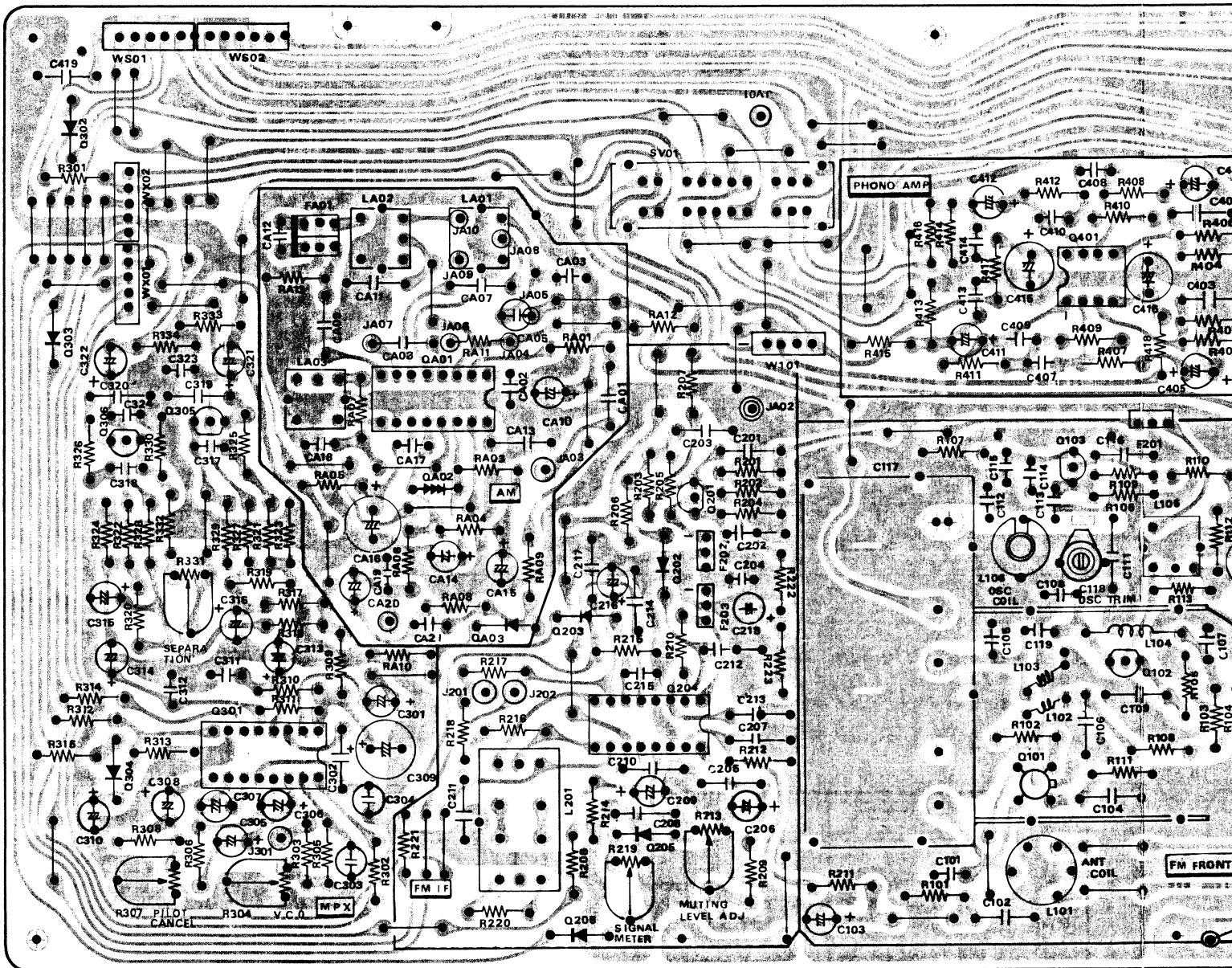

5.5 Switch Assembly (PS00) Schematic Diagram and Component Locations

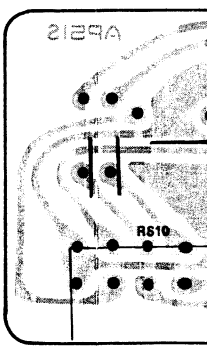
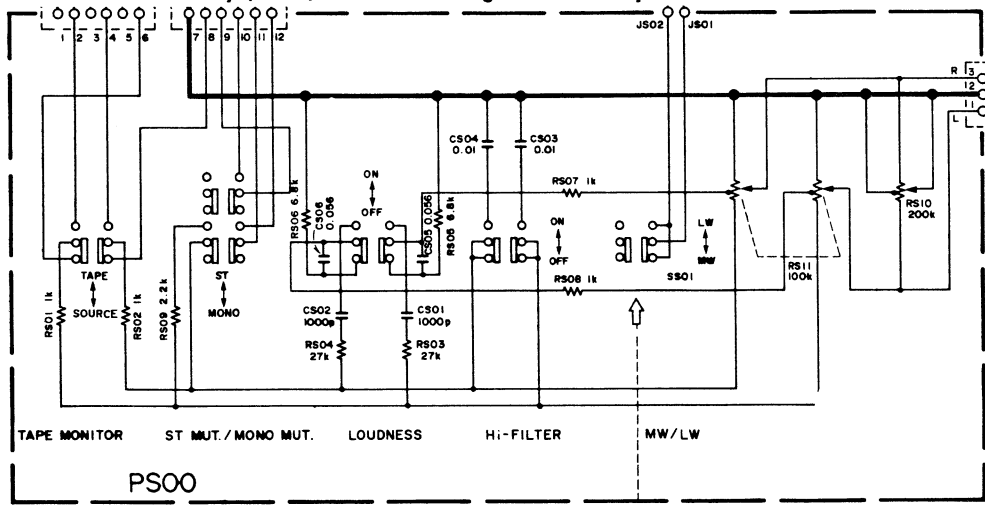



X

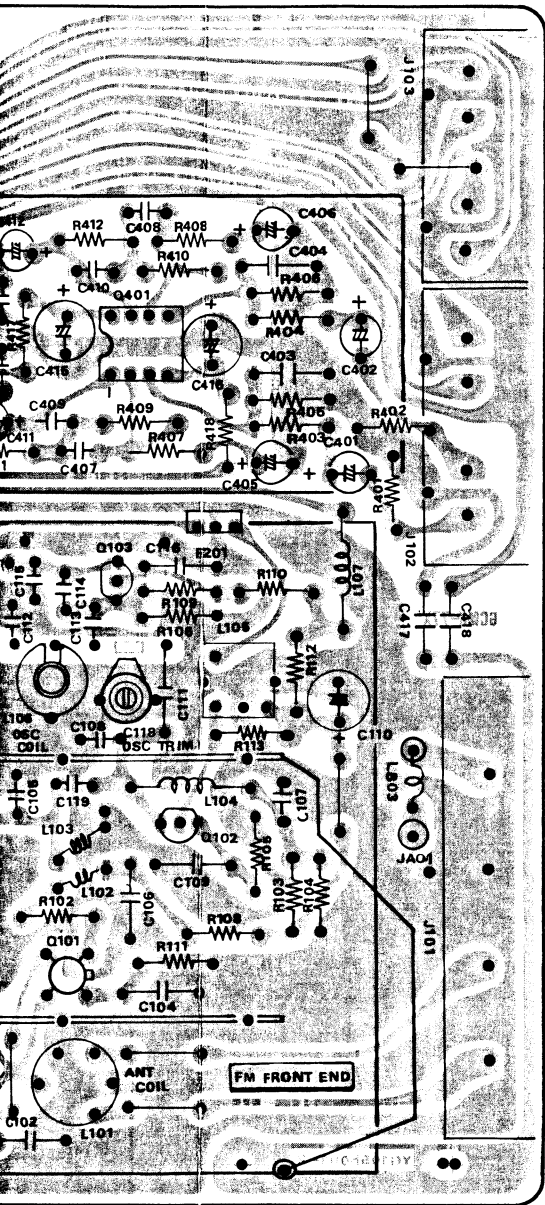

### 5.6 Speaker Terminal (PT00) Schematic Diagram and Component Locations

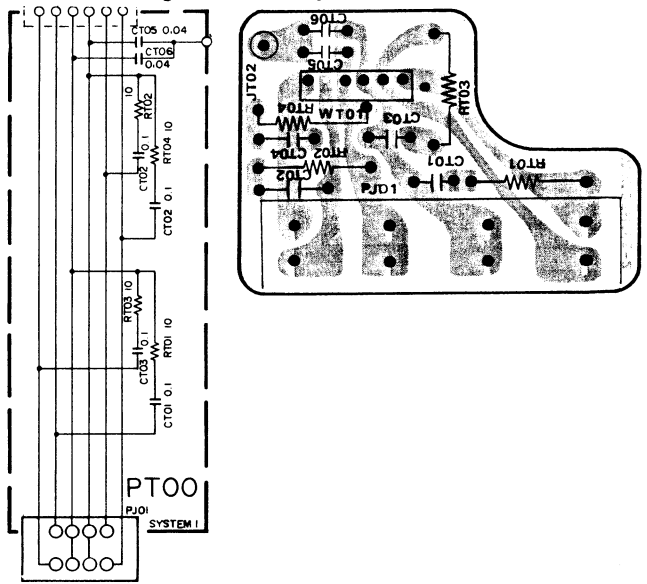

### 5.7 Power Switch (PU00) Schematic Diagram and Component Locations

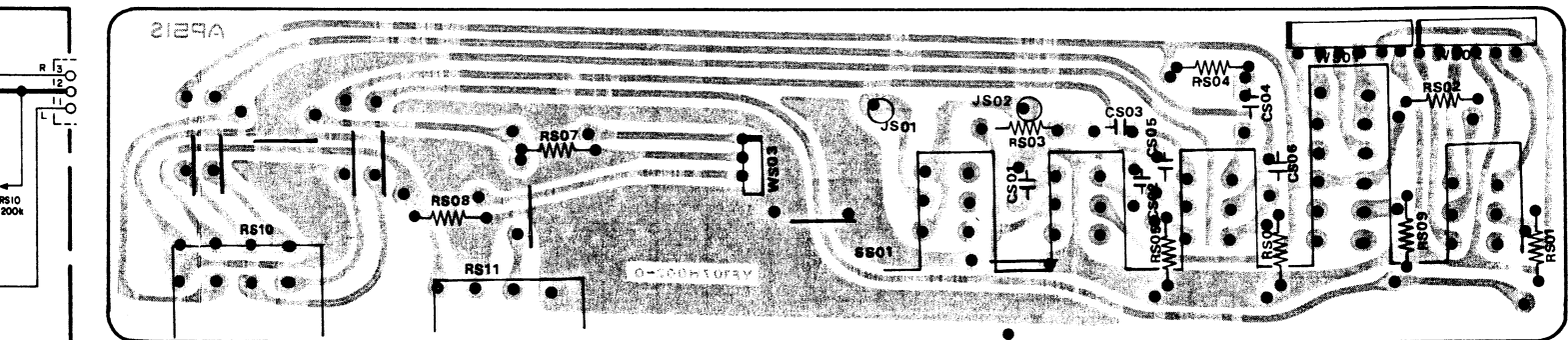
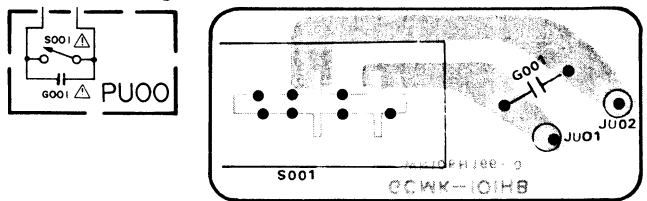

# 6. BLOCK DIAGRAM

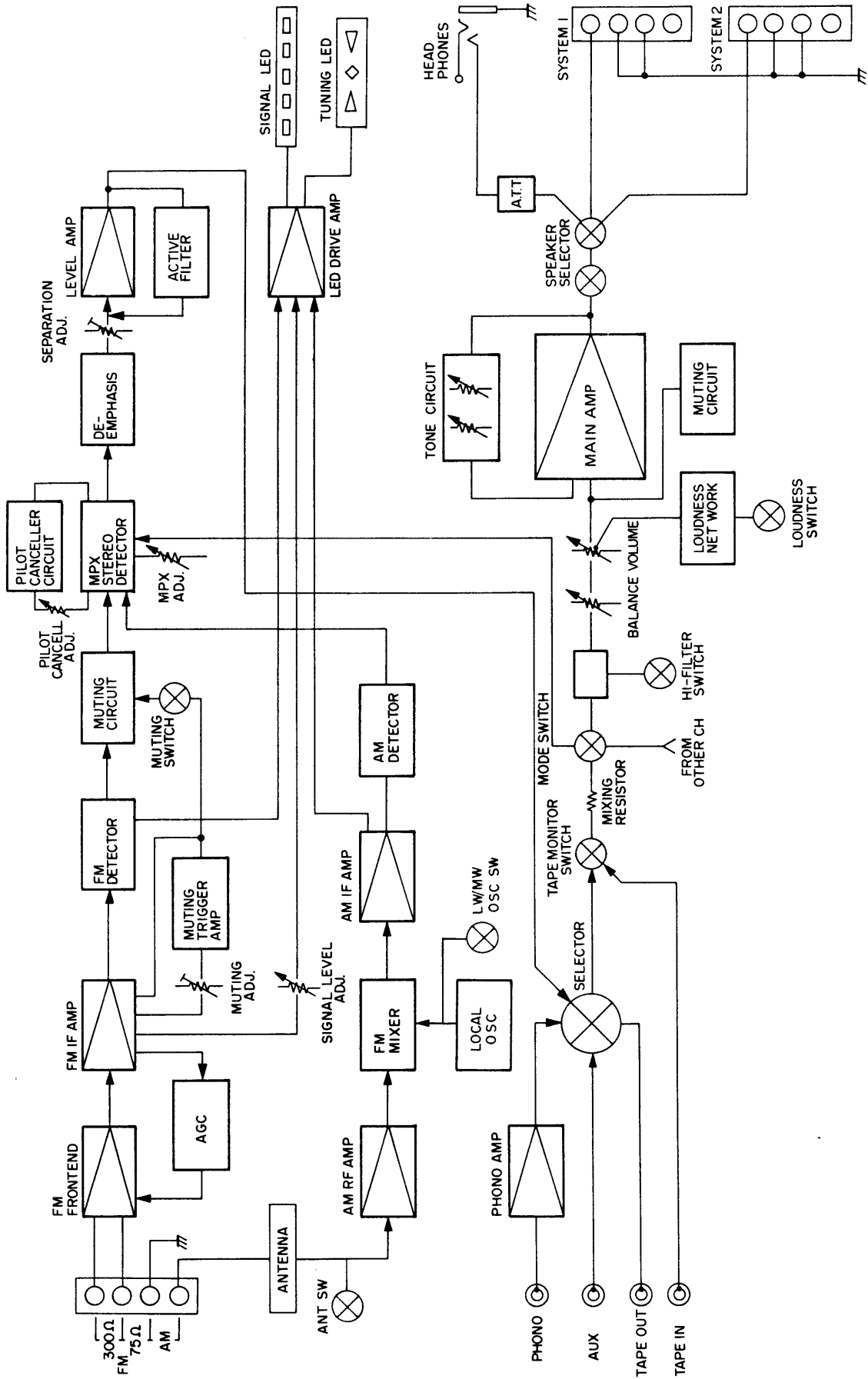

# 7. EXPLODED VIEWS AND PARTS LIST

## 7.1 [C01-99] Front Panel

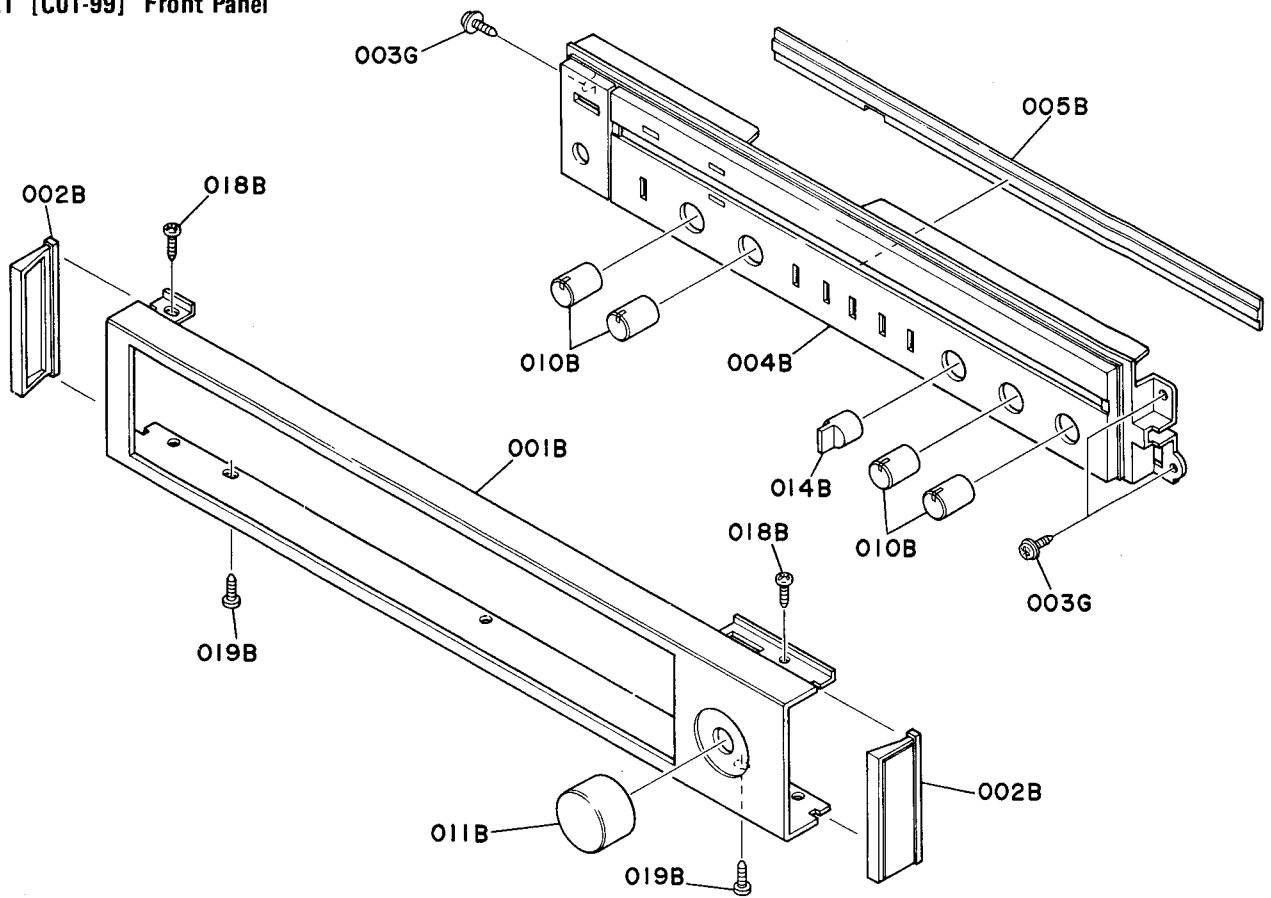

• (N): for Europe  
 • (T): for United Kingdom

REF. DESIG.	Q'TY		PART NO.	DESCRIPTION
	N	T		
A	1	1	105H063400	Front Panel, Assembly
001B	1	1	105H063010	Escutcheon, Front Panel
002B	2	2	403H067010	Cap, Panel Side
B	1	1	107H063400	Dial Panel Assembly
004B	1	1	107H063010	Escutcheon, Dial Panel
005B	1	1	105H158010	Window

REF. DESIG.	Q'TY		PART NO.	DESCRIPTION
	N	T		
010B	4	4	105H154020	Knob, Bass, Treble, Vol., Bal.
011B	1	1	403H154020	Knob, Tuning
014B	1	1	105H154060	Knob, Selector
018B	2	2	51300306B0	P.H. Tapped Screw P3 x 6
019B	2	2	51300306B0	P.H. Tapped Screw P3 x 6
003G	3	3	51280308B0	B.H. Tapped Screw B3 x 8



7.2 [C02-99] Top Cover

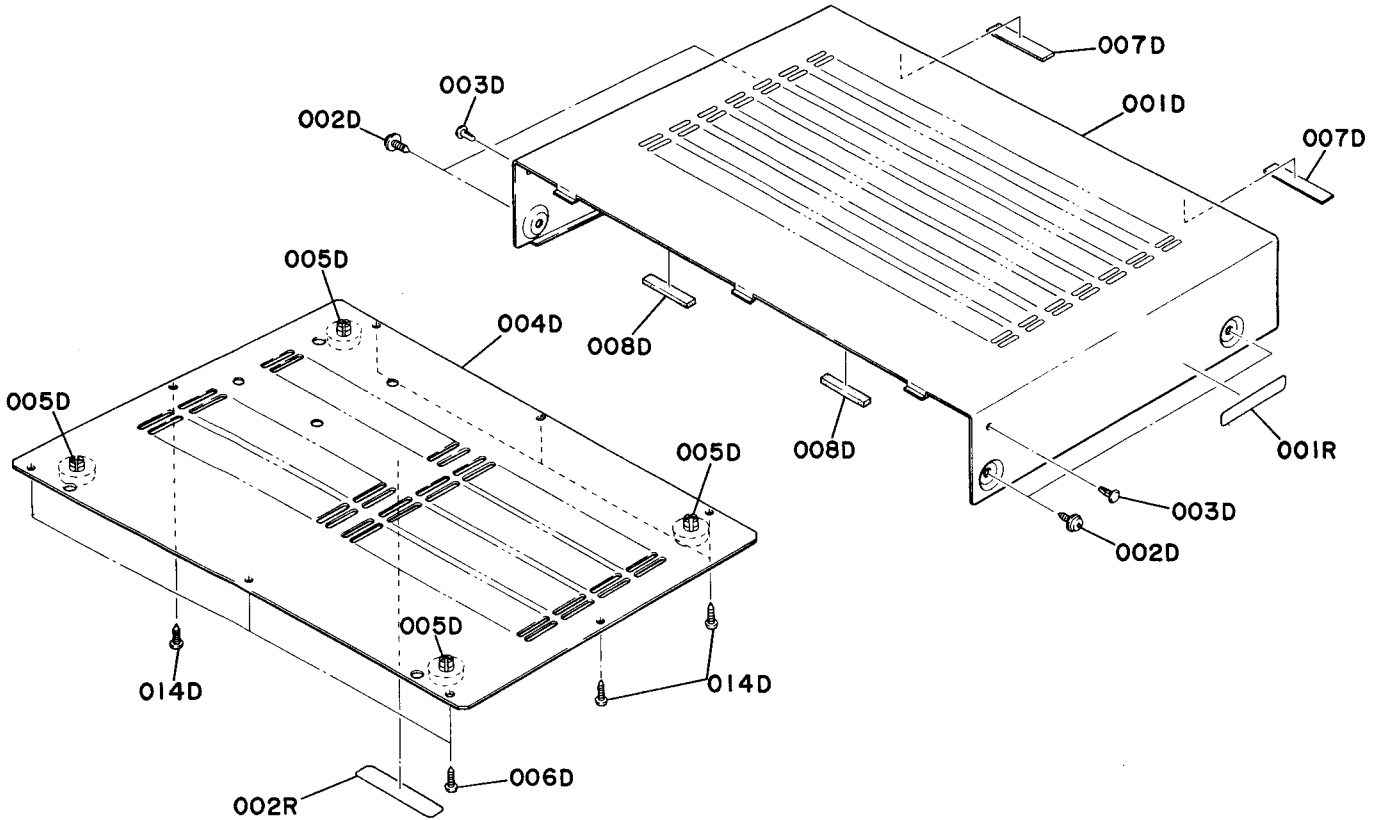

• (N): for Europe  
• (T): for United Kingdom

REF. DESIG.	Q'TY		PART NO.	DESCRIPTION
	N	T		
001D	1	1	208H257010	Lid, Top Cover
002D	4	4	51260408U0	B.T. Screw B4 x 8
003D	2	2	2991259110	Bushing
004D	1	1	105H257010	Lid, Bottom Cover
005D	4	4	403H057010	Leg
006D	3	3	51280308B0	B.H. Tapped Screw B3 x 8
007D	2	2	2965118010	Spacer
008D	2	2	208H056010	Buffer
014D	5	5	51280308B0	B.H. Tapped Screw B3 x 8

REF. DESIG.	Q'TY		PART NO.	DESCRIPTION
	N	T		
001R	1	1	2932861110	Label, Top Cover
002R	1	1	2578861010	Label, Bottom Cover

### 7.3 [C03-99] Rear Panel

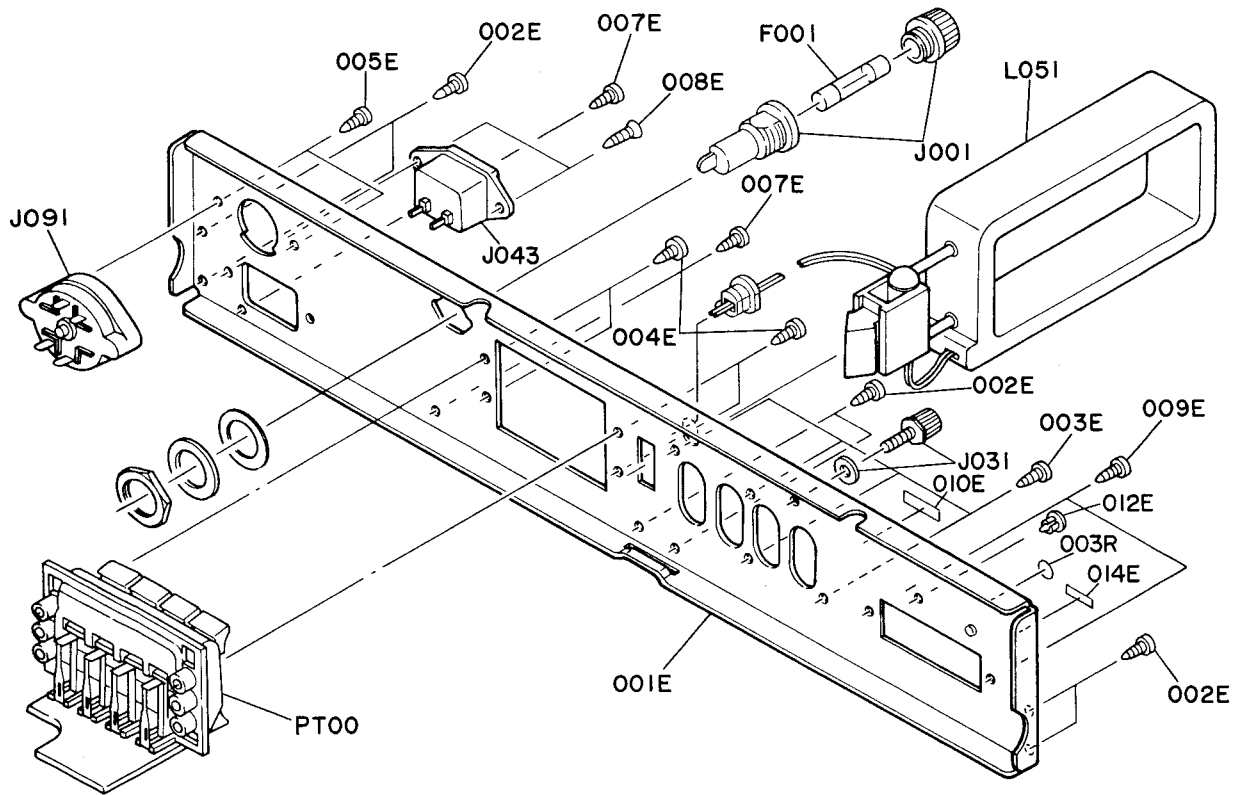

• (N): for Europe  
• (T): for United Kingdom

REF. DESIG.	Q'TY		PART NO.	DESCRIPTION
	N	T		
001E	1		107H160210	Bracket, Rear Panel
001E		1	107H160220	Bracket, Rear Panel
002E	6	6	51280308U0	B.H. Tapped Screw B3 x 8
003E	4	4	51280308U0	B.H. Tapped Screw B3 x 8
004E	4	4	51280308U0	B.H. Tapped Screw B3 x 8
005E	2	2	51280308U0	B.H. Tapped Screw B3 x 8
007E	2	2	51280308U0	B.H. Tapped Screw B3 x 8
008E	2	2	51420308T0	O.C.H. Tapped Screw O3 x 8
009E	2	2	51280308U0	B.H. Tapped Screw B3 x 8
010E	1	1	2112265010	Indicator
012E	1	1	2912259020	Bushing
014E	1	1	4581861010	Label, Made in Japan

REF. DESIG.	Q'TY		PART NO.	DESCRIPTION
	N	T		
003R		1	4204861020	Label
△F001	1	1	FS10080800	Fuse T800mA
△J001	1	1	YJ08000290	Jack, Fuse Holder
J031	1	1	YL03010250	Terminal, GND.
△J043	1	1	YP04000590	Plug, AC Inlet
△J091		1	BY05060040	Voltage Selector
△J091		1	BY05030030	Voltage Selector
L051	1	1	LA00015010	Loop Ant.

### 7.4 [P01-99] Front Chassis and General Parts

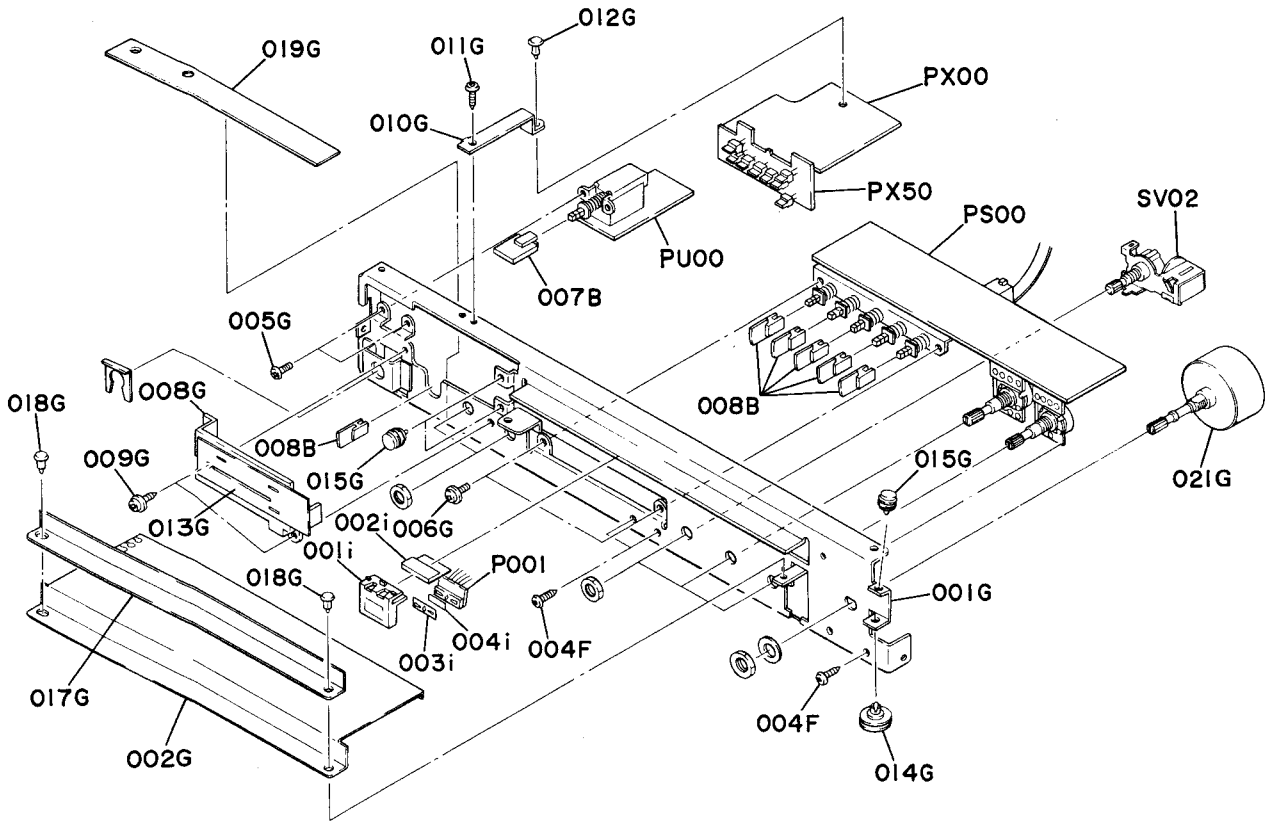

• (N): for Europe  
• (T): for United Kingdom

REF. DESIG.	Q'TY		PART NO.	DESCRIPTION
	N	T		
007B	1	1	208H154060	Knob, Power Switch
008B	6	6	105H154010	Knob, Push Switch
004F	3	3	51280306B0	B.H. Tapped Screw B3 x 6
001G	1	1	105H160010	Bracket, Front Chassis
002G	1	1	105H120010	Insulator
005G	2	2	51100306A9	B.H.M. Screw B3 x 6
006G	2	2	51100306A9	B.H.M. Screw B3 x 6
008G	1	1	105H118010	Spacer, LED
009G	2	2	51260308B0	B.T. Screw B3 x 8
010G	1	1	105H160020	Bracket
011G	1	1	51280308B0	B.H. Tapped Screw B3 x 8
012G	1	1	2276005050	Clamper
013G	1	1	105H118020	Spacer

REF. DESIG.	Q'TY		PART NO.	DESCRIPTION
	N	T		
014G	1	1	2259262500	Pulley
015G	3	3	2276262500	Pulley
017G	1	1	105H053010	Cover, Pointer
018G	2	2	2912259020	Bushing
019G	1	1	105H120020	Insulator
021G	1	1	105H273010	Flywheel
001i	1	1	403H103010	Pointer
002i	1	1	403H118010	Spacer
003i	1	1	403H303020	Mask
004i	1	1	403H303030	Mask
SV02	1	1	SR00040080	Rotary Switch, Selector

### 7.5 [P02-99] Chassis and Other Parts

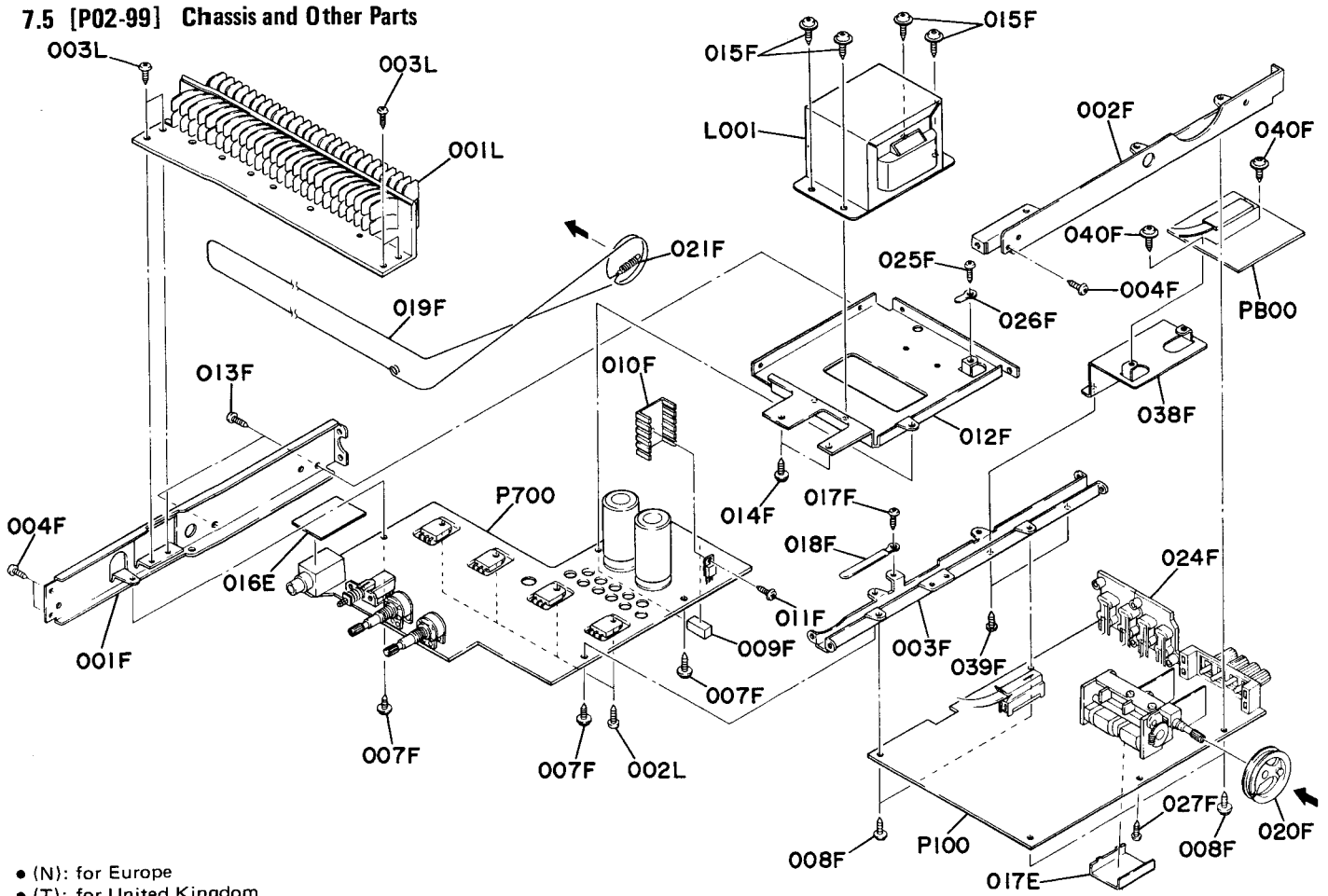

- (N): for Europe
- (T): for United Kingdom

REF. DESIG.	Q'TY		PART NO.	DESCRIPTION
	N	T		
001F	1	1	105H126010	Stay, Left
002F	1	1	105H126020	Stay, Right
003F	1	1	105H126030	Stay, Center
004F	3	3	51280306B0	B.H. Tapped Screw B3 x 6
007F	4	4	51260308B0	B.T. Screw B3 x 8
008F	4	4	51260308B0	B.T. Screw B3 x 8
009F	1	1	2218056010	Buffer
010F	1	1	202H267030	Heatsink
011F	1	1	51280308B0	B.H. Tapped Screw B3 x 8
012F	1	1	105H004010	Table, Transformer
013F	2	2	51280308B0	B.H. Tapped Screw B3 x 8
014F	2	2	51260308B0	B.T. Screw B3 x 8
015F	4	4	51260408U0	B.T. Screw B4 x 8
017F	1	1	51280306B0	B.H. Tapped Screw B3 x 6
018F	1	1	2871005010	Clamper
019F	1	1	72040805A0	String (135)
020F	1	1	403H159010	Drum, Dial
021F	1	1	2112115020	Spring
024F	2	2	2259109040	Shield
025F	1	1	51280306B0	B.H. Tapped Screw B3 x 6
026F	1	1	62030049W0	Lug
027F	1	1	51280308B0	B.H. Tapped Screw B3 x 8
038F	1	1	107H160010	Bracket
039F	2	2	51280308B0	B.H. Tapped Screw B3 x 8
040F	2	2	51260308B0	B.T. Screw B3 x 8
016E	1	1	208H120010	Insulator
017E	1	1	105H109010	Shield

REF. DESIG.	Q'TY		PART NO.	DESCRIPTION
	N	T		
001L	1	1	105H267010	Heatsink
002L	4	4	51280310B0	B.H. Tapped Screw B3 x 10
003L	4	4	51280308B0	B.H. Tapped Screw B3 x 10
ΔL001	1	1	TS16626020	Power Transformer
ΔL001	1	1	TS16626060	Power Transformer

## 7.6 [H01-99] Packing Materials

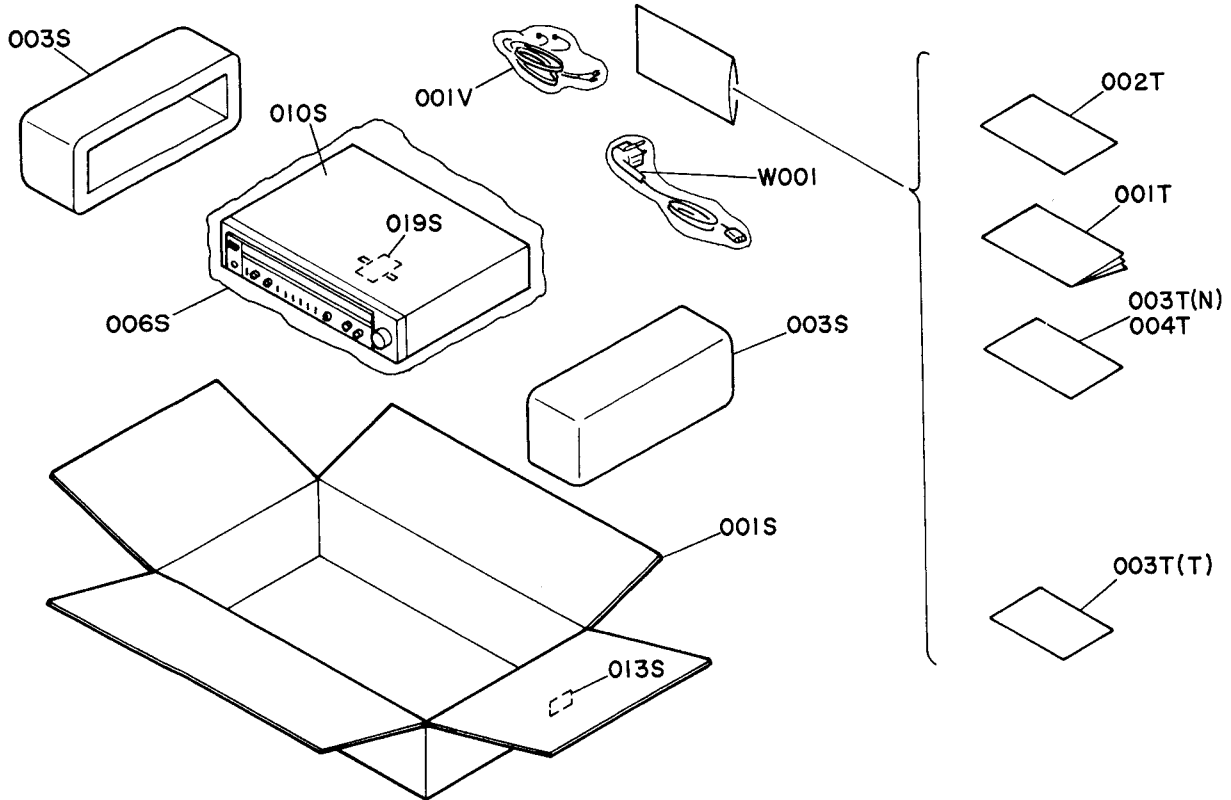

- (N): for Europe
- (T): for United Kingdom

REF. DESIG.	Q'TY		PART NO.	DESCRIPTION
	N	T		
001S	1	1	107H801010	Packing Case
003S	2	2	001H809010	Cushion
006S	1	1	9090909040	Polyethylene Sheet
010S	1	1	2918107350	Sheet
013S	4		9526019060	Serial No. Card
019S	1	1	2731821010	Silicage!
001T	1	1	105H851310	Instructions
002T	1	1	105H851320	Instructions
003T	1		107H856010	Circuit Diagram
003T		1	9630000200	Guarantee Card
004T		1	107H856010	Circuit Diagram

REF. DESIG.	Q'TY		PART NO.	DESCRIPTION
	N	T		
001V	1	1	ZA02000070	EXT. Antenna
ΔW001	1		ZC01805030	AC Power Cord
ΔW001		1	ZC01804030	AC Power Cord

7.7 ELECTRICAL PARTS

• (N): for Europe  
• (T): for United Kingdom

REF. DESIG.	Q'TY		PART NO.	DESCRIPTION
	N	T		
P100	1	1	YG105H0010	<b>P100-TUNER CIRCUIT BOARD</b> P.W. Board, Tuner
	1	1	ZZ107H8010	
<b>P100-CAPACITORS</b>				
CA01	1	1	DA17103010	Ceramic 0.01µF ±20%
CA02	1	1	DK16102300	Ceramic 1000pF ±10%
CA07	1	1	DA17103010	Ceramic 0.01µF ±20%
CA09	1	1	DA17103010	Ceramic 0.01µF ±20%
CA10	1	1	EA10701630	Elect 100µF 16V
CA11	1	1	DA17103010	Ceramic 0.01µF ±20%
CA12	1	1	DD15680370	Ceramic 68pF ±15%
CA13	1	1	DA17103010	Ceramic 0.01µF ±20%
CA14	1	1	EA10601630	Elect 10µF 16V
CA15	1	1	EA47505030	Elect 4.7µF 50V
CA16	1	1	EA33601630	Elect 33µF 16V
CA17	1	1	DK18103320	Ceramic 0.01µF +80% -20%
CA18	1	1	DK16102300	Ceramic 1000pF ±10%
CA19	1	1	DF16333300	Film 0.033µF ±10%
CA20	1	1	DF17333300	Film 0.033µF ±20%
CA21	1	1	DF17103300	Film 0.01µF ±20%
C101	1	1	DD11100300	Ceramic 10pF ±0.5pF
C102	1	1	DA17103010	Ceramic 0.01µF ±20%
C103	1	1	EA33405030	Elect 0.33µF 50V
C104	1	1	DA17103010	Ceramic 0.01µF ±20%
C105	1	1	DD15150300	Ceramic 15pF ±5%
C106	1	1	DA17103010	Ceramic 0.01µF ±20%
C107	1	1	DD15301360	Ceramic 300pF ±5%
C108	1	1	DD15200300	Ceramic 20pF ±5%
C109	1	1	DA17103010	Ceramic 0.01µF ±20%
C110	1	1	EA10701630	Elect 100µF 16V
C111	1	1	DD10010370	Ceramic 1pF ±0.25pF
C112	1	1	DD15200340	Ceramic 20pF ±5%
C113	1	1	DD11100300	Ceramic 10pF ±0.5pF
C114	1	1	DD15300310	Ceramic 30pF ±5%
C115	1	1	DD15150300	Ceramic 15pF ±5%
C116	1	1	DA17103010	Ceramic 0.01µF ±20%
C117	1	1	CA32200060	Variable FM-3, AM-2
C118	1	1	CT11000080	Trimming 10pF
C119	1	1	DD10050370	Ceramic 5pF ±0.25pF
C201	1	1	DA17103010	Ceramic 0.01µF ±20%
C202	1	1	DA17103010	Ceramic 0.01µF ±20%
C203	1	1	DA17103010	Ceramic 0.01µF ±20%
C205	1	1	DA17103010	Ceramic 0.01µF ±20%
C206	1	1	EA22505030	Elect 2.2µF 50V
C207	1	1	DA17103010	Ceramic 0.01µF ±20%
C208	1	1	DA17103010	Ceramic 0.01µF ±20%
C209	1	1	EA10505030	Elect 1µF 50V
C210	1	1	DA17103010	Ceramic 0.01µF ±20%
C211	1	1	DA17103010	Ceramic 0.01µF ±20%
C212	1	1	DK18403320	Ceramic 0.04µF +80% -20%
C213	1	1	DK18403320	Ceramic 0.04µF +80% -20%
C214	1	1	EA22505030	Elect 2.2µF 50V
C215	1	1	DD15300370	Ceramic 30pF ±5%
C216	1	1	EA47405030	Elect 0.47µF 50V
C217	1	1	DA17103010	Ceramic 0.01µF ±20%
C301	1	1	EA10601630	Elect 10µF 16V
C302	1	1	DA17103010	Ceramic 0.01µF ±20%

REF. DESIG.	Q'TY		PART NO.	DESCRIPTION
	N	T		
C303	1	1	DF55511090	Film 510pF ±5%
C304	1	1	DF55821090	Film 820pF ±5%
C305	1	1	EA47503530	Elect 4.7µF 35V
C306	1	1	EA10505030	Elect 1µF 50V
C307	1	1	EQ10505010	Elect 1µF 50V (NP)
C308	1	1	EA10505030	Elect 1µF 50V
C309	1	1	EA22701630	Elect 220µF 16V
C310	1	1	EA10505030	Elect 1µF 50V
C311	1	1	DF16153300	Film 0.015µF ±10%
C312	1	1	DF16153300	Film 0.015µF ±10%
C313	1	1	EA47405030	Elect 0.47µF 50V
C314	1	1	EA47405030	Elect 0.47µF 50V
C315	1	1	EA10601630	Elect 10µF 16V
C316	1	1	EA10601630	Elect 10µF 16V
C317	1	1	DF16332300	Film 3300pF ±10%
C318	1	1	DF16332300	Film 3300pF ±10%
C319	1	1	DA16181010	Ceramic 180pF ±10%
C320	1	1	DA16181010	Ceramic 180pF ±10%
C321	1	1	EA22505030	Elect 2.2µF 50V
C322	1	1	EA22505030	Elect 2.2µF 50V
C323	1	1	DF16102300	Ceramic 1000pF ±10%
C324	1	1	DK16102300	Ceramic 1000pF ±10%
C401	1	1	EA33505030	Elect 3.3µF 50V
C402	1	1	EA33505030	Elect 3.3µF 50V
C403	1	1	DA16331010	Ceramic 330pF ±10%
C404	1	1	DA16331010	Ceramic 330pF ±10%
C405	1	1	EA47501630	Elect 47µF 16V
C406	1	1	EA47601630	Elect 47µF 16V
C407	1	1	DF16332300	Film 3300pF ±10%
C408	1	1	DF16332300	Film 3300pF ±10%
C409	1	1	DF16123300	Film 0.012µF ±10%
C410	1	1	DF16123300	Film 0.012µF ±10%
C411	1	1	EA47505030	Elect 4.7µF 50V
C412	1	1	EA47505030	Elect 4.7µF 50V
C413	1	1	DD15101370	Ceramic 100pF ±5%
C414	1	1	DD15101370	Ceramic 100pF ±5%
C415	1	1	EA10701630	Elect 100µF 16V
C416	1	1	EA10701630	Elect 100µF 16V
C417	1	1	DA17103010	Ceramic 0.01µF ±20%
C418	1	1	DA17103010	Ceramic 0.01µF ±20%
C419	1	1	DA17103010	Ceramic 0.01µF ±20%
<b>P100-RESISTORS</b> (All Resistors are ±5% and ¼W)				
RA01	1	1	GD05221140	220Ω
RA03	1	1	GD05103140	10KΩ
RA04	1	1	GD05103140	10KΩ
RA05	1	1	GD05221140	220Ω
RA06	1	1	GD05222140	2.2KΩ
RA07	1	1	GD05331140	330Ω
RA08	1	1	GD05223140	22KΩ
RA09	1	1	GD05104140	100KΩ
RA10	1	1	GD05104140	100KΩ
RA11	1	1	GD05152140	1.5KΩ
RA12	1	1	GD05101140	100Ω
RA13	1	1	GD05332140	3.3KΩ
R101	1	1	GD05104140	100KΩ
R102	1	1	GD05101140	100Ω
R103	1	1	GD05223140	22KΩ
R104	1	1	GD05472140	4.7KΩ
R105	1	1	GD05102140	1KΩ

- (N): for Europe
- (T): for United Kingdom

REF. DESIG.	Q'TY		PART NO.	DESCRIPTION
	N	T		
R106	1	1	GD05103140	10K $\Omega$
R107	1	1	GD05562140	5.6K $\Omega$
R108	1	1	GD05470140	47 $\Omega$
R109	1	1	GD05103140	10K $\Omega$
R110	1	1	GD04101140	100 $\Omega$
R111	1	1	GD05100140	10 $\Omega$
R112	1	1	GD05470140	47 $\Omega$
R113	1	1	GD05273140	27K $\Omega$
R201	1	1	GD05331140	330 $\Omega$
R202	1	1	GD05272140	2.7K $\Omega$
R203	1	1	GD05153140	15K $\Omega$
R204	1	1	GD05561140	560 $\Omega$
R205	1	1	GD05331140	330 $\Omega$
R206	1	1	GD05221140	220 $\Omega$
R207	1	1	GD05154140	150K $\Omega$
R208	1	1	GD05222140	2.2K $\Omega$
R209	1	1	GD05103140	10K $\Omega$
R210	1	1	GD05331140	330 $\Omega$
R211	1	1	GD05223140	22K $\Omega$
R212	1	1	GD05104140	100K $\Omega$
R213	1	1	RA05030090	50K $\Omega$ (B) Trimming
R214	1	1	GD05124140	120K $\Omega$
R215	1	1	GD05563140	56K $\Omega$
R216	1	1	GD05183140	18K $\Omega$
R217	1	1	GD05821140	820 $\Omega$
R218	1	1	GD05123140	12K $\Omega$
R219	2	1	RA05020160	5K $\Omega$ (B) Trimming
R220	1	1	GD05272140	2.7K $\Omega$
R221	1	1	GD05223140	22K $\Omega$
R301	1	1	GD05103140	10K $\Omega$
R302	1	1	GD05473140	47K $\Omega$
R303	1	1	GD05224140	220K $\Omega$
R304	1	1	RA05020160	5K $\Omega$ (B) Trimming
R305	1	1	GD05153140	15K $\Omega$
R306	1	1	GD05821140	820 $\Omega$
R307	1	1	RA05020160	5K $\Omega$ (B) Trimming
R308	1	1	GD05102140	1K $\Omega$
R309	1	1	RF05390140	39 $\Omega$
R310	1	1	GD05472140	4.7K $\Omega$
R311	1	1	GD05472140	4.7K $\Omega$
R312	1	1	GD05154140	150K $\Omega$
R313	1	1	GD05473140	47K $\Omega$
R314	1	1	GD05392140	3.9K $\Omega$
R315	1	1	GD05103140	10K $\Omega$
R317	1	1	GD05221140	220 $\Omega$
R318	1	1	GD05221140	220 $\Omega$
R319	1	1	GD05104140	100K $\Omega$
R320	1	1	GD05104140	100K $\Omega$
R321	1	1	GD05103140	10K $\Omega$
R322	1	1	GD04103140	10K $\Omega$
R323	1	1	GD05183140	18K $\Omega$
R324	1	1	GD05183140	18K $\Omega$
R325	1	1	GD05103140	10K $\Omega$
R326	1	1	GD05103140	10K $\Omega$
R327	1	1	GD05332140	3.3K $\Omega$
R328	1	1	GD05332140	3.3K $\Omega$
R329	1	1	GD05391140	390 $\Omega$
R330	1	1	GD05391140	390 $\Omega$
R333	1	1	GD05104140	100K $\Omega$
R334	1	1	GD05104140	100K $\Omega$
R401	1	1	GD05104140	100K $\Omega$
R402	1	1	GD05104140	100K $\Omega$
R403	1	1	GD05222140	2.2K $\Omega$

REF. DESIG.	Q'TY		PART NO.	DESCRIPTION
	N	T		
R404	1	1	GD05222140	2.2K $\Omega$
R405	1	1	GD05104140	100K $\Omega$
R406	1	1	GD05104140	100K $\Omega$
R407	1	1	GD05471140	470 $\Omega$
R408	1	1	GD05471140	470 $\Omega$
R409	1	1	GD05223140	22K $\Omega$
R410	1	1	GD05223140	22K $\Omega$
R411	1	1	GD05274140	270K $\Omega$
R412	1	1	GD05274140	270K $\Omega$
R413	1	1	GD05224140	220K $\Omega$
R414	1	1	GD05224140	220K $\Omega$
R415	1	1	GD05221140	220 $\Omega$
R416	1	1	GD05221140	220 $\Omega$
R417	1	1	GG05221140	220 $\Omega$
R418	1	1	GG05221140	220 $\Omega$
QA01	1	1	HC10041030	IC LA1240
QA02	1	1	HV00006120	Varistor MV203
QA03	1	1	HD20001210	Diode 1S2473
Q101	1	1	HF400451B0	F.E.T. 3SK45B
Q102	1	1	HT310471C0	Transistor 2SC1047(C)
Q103	1	1	HT308291C0	Transistor 2SC829(C)
Q201	1	1	HT308291C0	Transistor 2SC829(C)
Q202	1	1	HD20001210	Diode 1S2473
Q203	1	1	HD20001210	Diode 1S2473
Q204	1	1	HC10028030	IC LA1231
Q205	1	1	HD20001210	Diode 1S2473
Q206	1	1	HD20001210	Diode 1S2473
Q301	1	1	HC10001420	IC KB4437
Q302	1	1	HD20001210	Diode 1S2473
Q303	1	1	HD20001210	Diode 1S2473
Q304	1	1	HD20001210	Diode 1S2473
Q305	1	1	HT309452A0	Transistor 2SC945(O or R)
Q306	1	1	HT309452A0	Transistor 2SC945(O or R)
Q401	1	1	HC10008090	IC JRC4558
FA01	1	1	FF10045200	P100-MISCELLANEOUS Ceramic Filter, 450kHz
F201	1	1	FF11070530	Ceramic Filter, SFE 10.7MHz
F202	1	1	FF11070570	Ceramic Filter, SFE 10.7MHz
F203	1	1	FF11070570	Ceramic Filter, SFE 10.7MHz
J101	1	1	YT01040230	Terminal, Antenna
J102	1	1	YT02040260	Terminal, RCA Pin Jack (4P)
J103	1	1	YT02040260	Terminal, RCA Pin Jack (4P)
LA02	1	1	LI10010730	I.F.T. Coil
LA03	1	1	LI10015060	I.F.T. Coil
L101	1	1	LA12026170	Antenna Coil, FM
L102	1	1	LL24800030	Coil, FM RF
L103	1	1	LK11800030	Coil, FM RF
L104	1	1	LC17510010	Choke Coil, 0.75 $\mu$ H
L105	1	1	LI10016010	I.F.T. Coil
L106	1	1	LO12036010	OSC Coil, FM
L107	1	1	LC13320050	Choke Coil, 3.3 $\mu$ H
L201	1	1	LI14030020	I.F.T. Coil, FM Det
SV01	1	1	SS04040040	Slide Switch
SV02	1	1	SR00040080	Rotary Switch
W101	1	1	YU04120260	Jumper Lead, (4P)

- (N): for Europe
- (T): for United Kingdom

REF. DESIG.	Q'TY		PART NO.	DESCRIPTION
	N	T		
P700	1	1	YK105H1610	<b>P700-MAIN AMP. &amp; POWER SUPPLY CIRCUIT BOARD</b>
	1	1	ZZ105H1610	P.W. Board, Main Amp. & Power Supply P.W. Board Assembly
<b>P700-CAPACITORS</b>				
CE01	1	1	EA10601630	Elect 10 $\mu$ F 16V
CE02	1	1	EA10601630	Elect 10 $\mu$ F 16V
CE03	1	1	DF16152300	Film 1500pF $\pm$ 10%
CE04	1	1	DF16152300	Film 1500pF $\pm$ 10%
CE05	1	1	DF16153300	Film 0.015 $\mu$ F $\pm$ 10%
CE06	1	1	DF16153300	Film 0.015 $\mu$ F $\pm$ 10%
CE07	1	1	DF16562300	Film 5600pF $\pm$ 10%
CE08	1	1	DF16562300	Film 5600pF $\pm$ 10%
CE09	1	1	DF16473300	Film 0.047 $\mu$ F $\pm$ 10%
CE10	1	1	DF16473300	Film 0.047 $\mu$ F $\pm$ 10%
CK01	1	1	EA47601030	Elect 47 $\mu$ F 10V
CK02	1	1	EA10700630	Elect 100 $\mu$ F 6.3V
CK03	1	1	EA10703530	Elect 100 $\mu$ F 35V
CN01	1	1	DF17332300	Film 0.033 $\mu$ F $\pm$ 20%
CN02	2	2	DF17332300	Film 0.033 $\mu$ F $\pm$ 20%
CN03	1	1	DF17332300	Film 0.033 $\mu$ F $\pm$ 20%
CN04	1	1	DF17332300	Film 0.033 $\mu$ F $\pm$ 20%
C701	1	1	EA33505030	Elect 3.3 $\mu$ F 50V
C702	1	1	EA33505030	Elect 3.3 $\mu$ F 50V
C703	1	1	DD15221370	Ceramic 220pF $\pm$ 5%
C704	1	1	DD15221370	Ceramic 220pF $\pm$ 5%
C705	1	1	DD15151370	Ceramic 150pF $\pm$ 5%
C706	1	1	DD15151370	Ceramic 150pF $\pm$ 5%
C707	1	1	DD11100370	Ceramic 10pF $\pm$ 0.5pF
C708	1	1	DD11100370	Ceramic 10pF $\pm$ 0.5pF
C709	1	1	EA10701030	Elect 100 $\mu$ F 10V
C710	1	1	EA10701030	Elect 100 $\mu$ F 10V
C711	1	1	EA47603530	Elect 47 $\mu$ F 35V
C712	1	1	EA47603530	Elect 47 $\mu$ F 35V
C713	1	1	DD15101560	Ceramic 100pF $\pm$ 5%
C714	1	1	DD15101560	Ceramic 100pF $\pm$ 5%
C717	1	1	DD11100370	Ceramic 10pF $\pm$ 0.5pF
C718	1	1	DD11100370	Ceramic 10pF $\pm$ 0.5pF
C719	1	1	EA22703530	Elect 220 $\mu$ F 35V
C725	1	1	DD15330370	Ceramic 33pF $\pm$ 5%
C726	1	1	DD15330370	Ceramic 33pF $\pm$ 5%
C801	1	1	DK18103560	Ceramic 0.01 $\mu$ F
△C802	1	1	EB68804540	Elect 6800 $\mu$ F 45V
△C803	1	1	EB68804540	Elect 6800 $\mu$ F 45V
C804	1	1	EA47505030	Elect 4.7 $\mu$ F 50V
C805	1	1	EA22705030	Elect 220 $\mu$ F 50V
C806	1	1	EA10605030	Elect 10 $\mu$ F 50V
C807	1	1	EA10705030	Elect 100 $\mu$ F 50V
C808	1	1	EA33603530	Elect 33 $\mu$ F 35V
C809	1	1	EA10703530	Elect 100 $\mu$ F 35V
C810	1	1	EA10701630	Elect 100 $\mu$ F 16V

REF. DESIG.	Q'TY		PART NO.	DESCRIPTION
	N	T		
<b>P700-RESISTORS</b> (All Resistors are $\pm$ 5% and $\frac{1}{4}$ W)				
RE01	1	1	GD05183140	18K $\Omega$
RE02	1	1	GD05183140	18K $\Omega$
RE03	1	1	GD05183140	18K $\Omega$
RE04	1	1	GD05183140	18K $\Omega$
RE05	1	1	GD05183140	18K $\Omega$
RE06	1	1	GD05183140	18K $\Omega$
RE07	1	1	GD05103140	10K $\Omega$
RE08	1	1	GD05103140	10K $\Omega$
RE09	1	1	GD05332140	3.3K $\Omega$
RE10	1	1	GD05332140	3.3K $\Omega$
RE11	1	1	GD05222140	2.2K $\Omega$
RE12	1	1	GD05222140	2.2K $\Omega$
RE13	1	1	RM01040290	100K $\Omega$ (C) Variable
RE14	1	1	RM01040290	100K $\Omega$ (C) Variable
RK01	1	1	GD05473140	47K $\Omega$
RK02	1	1	GD05103140	10K $\Omega$
RK03	1	1	GD05474140	470K $\Omega$
RK04	1	1	GD05273140	27K $\Omega$
RK05	1	1	GD05473140	47K $\Omega$
RK06	1	1	GD05103140	10K $\Omega$
RK07	1	1	GD05474140	470K $\Omega$
RK08	1	1	GD05153140	15K $\Omega$
RK09	1	1	GD05332140	3.3K $\Omega$
RK10	1	1	GD05273140	27K $\Omega$
△RN01	1	1	GG05331140	330 $\Omega$
△RN02	1	1	GG05331140	330 $\Omega$
△RN03	1	1	GG05331140	330 $\Omega$
△RN04	1	1	GG05331140	330 $\Omega$
RN05	1	1	GD05222140	2.2K $\Omega$
RN06	1	1	GD05222140	2.2K $\Omega$
RN07	1	1	GD05222140	2.2K $\Omega$
RN08	1	1	GD05222140	2.2K $\Omega$
RN09	1	1	GD05103140	10K $\Omega$
RN10	1	1	GD05103140	10K $\Omega$
R701	1	1	GD05102140	1K $\Omega$
R702	1	1	GD05102140	1K $\Omega$
R703	1	1	GD05563140	56K $\Omega$
R704	1	1	GD05563140	56K $\Omega$
R705	1	1	GD05103140	10K $\Omega$
R706	1	1	GD05103140	10K $\Omega$
R707	1	1	GD05681140	680 $\Omega$
R708	1	1	GD05681140	680 $\Omega$
R709	1	1	GD05333140	33K $\Omega$
R710	1	1	GD05333140	33K $\Omega$
R711	1	1	GD05272140	2.7K $\Omega$
R712	1	1	GD05272140	2.7K $\Omega$
R713	1	1	GD05333140	33K $\Omega$
R714	1	1	GD05333140	33K $\Omega$
R715	1	1	GD05332140	3.3K $\Omega$
R716	1	1	GD05332140	3.3K $\Omega$
R717	1	1	GD05332140	3.3K $\Omega$
R718	1	1	GD05332140	3.3K $\Omega$
R719	1	1	GG05330140	33 $\Omega$
R720	1	1	GG05330140	33 $\Omega$



- (N): for Europe
- (T): for United Kingdom

REF. DESIG.	Q'TY		PART NO.	DESCRIPTION		
	N	T				
R721	1	1	GD05470140	47Ω		
R722	1	1	GD05470140	47Ω		
R723	1	1	GD05100140	10Ω		
R724	1	1	GD05100140	10Ω		
R725	1	1	GG05331120	330Ω		½W
R726	1	1	GG05331120	330Ω		½W
△R727	1	1	GO10332030	0.33Ω	±10%	3W
△R728	1	1	GO10332030	0.33Ω	±10%	3W
△R729	1	1	GO10332030	0.33Ω	±10%	3W
△R730	1	1	GO10332030	0.33Ω	±10%	3W
R733	1	1	GD05152140	1.5KΩ		
R734	1	1	GD05152140	1.5KΩ		
R735	1	1	GA05331010	330Ω		1W
R736	1	1	GA05331010	330Ω		1W
R737	1	1	GD05104140	100KΩ		
R738	1	1	GD05104140	100KΩ		
△R739	1	1	GD05152140	1.5KΩ		
R740	1	1	GD05102140	1KΩ		
R741	1	1	GD05104140	100KΩ		
R742	1	1	GD05104140	100KΩ		
R743	1	1	GD05104140	100KΩ		
R744	1	1	GD05821140	820Ω		
△R801	1	1	GA05390030	39Ω		3W
R802	1	1	GG05821140	820Ω		
R803	1	1	GG05821140	820Ω		
R804	1	1	GG05182140	1.8KΩ		
R805	1	1	GD05152140	1.5KΩ		
R806	1	1	GD05273140	27KΩ		
△R807	1	1	RF05056140	5.6Ω, Fusible		
<b>P700-SEMICONDUCTORS</b>						
QK01	1	1	HT309452A0	Transistor	2SC945(Q or R)	
QK02	1	1	HT309452A0	Transistor	2SC945(Q or R)	
QK03	1	1	HT309452A0	Transistor	2SC945(Q or R)	
QK04	1	1	HT309452A0	Transistor	2SC945(Q or R)	
QK05	1	1	HT309452A0	Transistor	2SC945(Q or R)	
QK06	1	1	HT309452A0	Transistor	2SC945(Q or R)	
QK07	1	1	HD30007090	Zener	WZ-140	
QN01	1	1	HT309452A0	Transistor	2SC945(Q or R)	
QN02	1	1	HT309452A0	Transistor	2SC945(Q or R)	
QN03	1	1	HT107332A0	Transistor	2SA733(Q or R)	
QN04	1	1	HT107332A0	Transistor	2SA733(Q or R)	
QN05	1	1	HD20001210	Diode	1S2473	
QN06	1	1	HD20001210	Diode	1S2473	
QN07	1	1	HD20001210	Diode	1S2473	
QN08	1	1	HD20001210	Diode	1S2473	
QN09	1	1	HD20001210	Diode	1S2473	
QN10	1	1	HD20001210	Diode	1S2473	
QN11	1	1	HD20001210	Diode	1S2473	
QN12	1	1	HD20001210	Diode	1S2473	
Q701	1	1	HT107502A0	Transistor	2SA750(F or E)	
Q702	1	1	HT107502A0	Transistor	2SA750(F or E)	
Q703	1	1	HT107502A0	Transistor	2SA750(F or E)	
Q704	1	1	HT107502A0	Transistor	2SA750(F or E)	
Q705	1	1	HT315092C0	Transistor	2SC1509(R or S)	
Q706	1	1	HT315092C0	Transistor	2SC1509(R or S)	
Q707	1	1	HV00006120	Varistor	MV203	
Q708	1	1	HV00006120	Varistor	MV203	
△Q709	1	1	HT315092C0	Transistor	2SC1509(R or S)	
△Q710	1	1	HT315092C0	Transistor	2SC1509(R or S)	

REF. DESIG.	Q'TY		PART NO.	DESCRIPTION	
	N	T			
△Q711	1	1	HT107772C0	Transistor	2SA777(R or S)
△Q712	1	1	HT107772C0	Transistor	2SA777(R or S)
△Q713	1	1	HT326652B0	Transistor	2SC2665(O or Y)
△Q714	1	1	HT326652B0	Transistor	2SC2665(O or Y)
Q715	1	1	HT111352B0	Transistor	2SA1135(O or Y)
Q716	1	1	HT111352B0	Transistor	2SA1135(O or Y)
Q717	1	1	HD20015030	Diode	DS135D
Q718	1	1	HD30047090	Zener	WZ192
Q719	1	1	HD20015030	Diode	DS135D
Q720	1	1	HD20015030	Diode	DS135D
Q721	1	1	HD20015030	Diode	DS135D
Q722	1	1	HD20015030	Diode	DS135D
Q723	1	1	HT317752D0	Transistor	2SC1775(D or C)
Q724	1	1	HT317752D0	Transistor	2SC1775(D or C)
△Q801	1	1	HD20009290	Diode	S2V-20
△Q802	1	1	HD20009290	Diode	S2V-20
△Q803	1	1	HD20009290	Diode	S2V-20
△Q804	1	1	HD20009290	Diode	S2V-20
△Q805	1	1	HD20015030	Diode	DS135D
△Q806	1	1	HD20015030	Diode	DS135D
△Q807	1	1	HD20015030	Diode	DS135D
△Q808	1	1	HT403131Q0	Transistor	2SD313(E)
Q809	1	1	HD30027090	Zener	WZ140
Q810	1	1	HD30027090	Zener	WZ140
<b>P700-MISCELLANEOUS</b>					
J051	1	1	YJ01001420	Jack, Headphone	
S701	1	1	SP02010590	Push Switch, Speaker A/B	
<b>PB00-ANT./OSC CIRCUIT BOARD</b>					
PB00	1	1	YF107H0010	P.W. Board, Ant./OSC	
			ZZ107H0010	P.W. Board Assembly	
<b>PB00-CAPACITORS</b>					
CB01	1	1	CT21600010	Trimming	15pF x 2
CB02	1	1	CT21600010	Trimming	15pF x 2
CB03	1	1	DD11100300	Ceramic	10pF ±0.5pF
CB04	1	1	DD15200300	Ceramic	20pF ±5%
CB05	1	1	DD15680330	Ceramic	68pF ±5%
CB06	1	1	DF55181090	Film	180pF ±5%
CB07	1	1	DF55391090	Film	390pF ±5%
CB08	1	1	DD11100390	Ceramic	10pF ±0.5pF
CB09	1	1	DK16102300	Ceramic	1000pF ±10%
CB10	1	1	DK17103300	Ceramic	0.01μF ±20%
<b>PB00-MISCELLANEOUS</b>					
LB01	1	1	LA10295010	Ant. Coil, MW	
LB02	1	1	LA10295020	Ant. Coil, LW	
LB03	1	1	LO10010480	OSC Coil, MW	
LB04	1	1	LO10010570	OSC Coil, LW	
LB05	1	1	LO10010480	OSC Coil, IF Trap	
LB06	1	1	LC13320050	Choke Coil, 3.3μH	
LB07	1	1	LO10010480	OSC Coil, MW	
SB01	1	1	SS06020490	Slide Switch, LW/MW	
SB02	1	1	SB12050010	Switch Band, FLX	

- (N): for Europe
- (T): for United Kingdom

REF. DESIG.	Q'TY		PART NO.	DESCRIPTION
	N	T		
PS00	1	1	YF107H0020 ZZ107H0020	<b>PS00-SWITCH ASSEMBLY CIRCUIT BOARD</b> P.W. Board, Switch Assembly P.W. Board Assembly
	1	1		
CS01	1	1	DF17103300	Film 0.01 $\mu$ F $\pm$ 20%
CS02	1	1	DF17103300	Film 0.01 $\mu$ F $\pm$ 20%
CS03	1	1	DF17102300	Film 1000pF $\pm$ 20%
CS04	1	1	DF17102300	Film 1000pF $\pm$ 20%
CS05	1	1	DF17563300	Film 0.056 $\mu$ F $\pm$ 20%
CS06	1	1	DF17563300	Film 0.056 $\mu$ F $\pm$ 20%
RS01	1	1	GD05102140	1K $\Omega$
RS02	1	1	GD05102140	1K $\Omega$
RS03	1	1	GD05273140	27K $\Omega$
RS04	1	1	GD05273140	27K $\Omega$
RS05	1	1	GD05562140	5.6K $\Omega$
RS06	1	1	GD05562140	5.6K $\Omega$
RS07	1	1	GD05102140	1K $\Omega$
RS08	1	1	GD05102140	1K $\Omega$
RS09	1	1	GD05222140	2.2K $\Omega$
RS10	1	1	RM01040270	100K $\Omega$ , Variable
RS11	1	1	RK02040120	200K $\Omega$ , Variable
SS01	1	1	SP04050210	<b>PS00-MISCELLANEOUS</b> Push Switch
WS01	1	1	YU06140260	Jumper Lead, (6P) 140mm
WS02	1	1	YU06140260	Jumper Lead, (6P) 140mm
WS03	1	1	YU03220260	Jumper Lead, (6P) 220mm
PT00	1	1	YK105H1650 ZZ105H1650	<b>PT00-SPEAKER TERMINAL CIRCUIT BOARD</b> P.W. Board, Speaker Terminal P.W. Board Assembly
CT01	1	1	DF17104500	Film 0.1 $\mu$ F $\pm$ 20%
CT02	1	1	DF17104500	Film 0.1 $\mu$ F $\pm$ 20%
CT03	1	1	DF17104500	Film 0.1 $\mu$ F $\pm$ 20%
CT04	1	1	DF17104500	Film 0.1 $\mu$ F $\pm$ 20%
CT05	1	1	DK18403320	Ceramic 0.04 $\mu$ F +80% -20%
CT06	1	1	DK18403320	Ceramic 0.04 $\mu$ F +80% -20%
RT01	1	1	GJ05100010	10 $\Omega$ $\pm$ 5% 1W
RT02	1	1	GJ05100010	10 $\Omega$ $\pm$ 5% 1W
RT03	1	1	GJ05100010	10 $\Omega$ $\pm$ 5% 1W
RT04	1	1	GJ05100010	10 $\Omega$ $\pm$ 5% 1W
PJ01	1	1	YT03080010	<b>PT00-MISCELLANEOUS</b> Terminal, SPK. (8P)
WT01	1	1	YU06500240	Jumper Lead, (6P) 500mm
PU00	1	1	YK105H1660 ZZ105H1660	<b>PU00-POWER SWITCH CIRCUIT BOARD</b> P.W. Board, Power Switch P.W. Board Assembly
$\Delta$ G001	1	1	DK18103840	Ceramic Cap. 0.01 $\mu$ F
$\Delta$ S001	1	1	SP01010390	Push Switch, Power

REF. DESIG.	Q'TY		PART NO.	DESCRIPTION
	N	T		
PX00	1	1	YK105H1620 ZZ105H1620	<b>PX00-SIGNAL &amp; TUNING LED CIRCUIT BOARD</b> P.W. Board, Signal & Tuning LED P.W. Board Assembly
CX01	1	1	EA10701630	<b>PX00-CAPACITORS</b> Elect 100 $\mu$ F 16V
CX01	1	1	EA47601030	Elect 47 $\mu$ F 10V
RX01	1	1	GD05102140	<b>PX00-RESISTORS</b> (All Resistors are $\pm$ 5% and $\frac{1}{4}$ W) 1K $\Omega$
RX02	1	1	GD05102140	1K $\Omega$
RX03	1	1	GD05221140	220 $\Omega$
RX04	1	1	GD05821140	820 $\Omega$
RX05	1	1	GD05152140	1.5K $\Omega$
RX06	1	1	GD05152140	1.5K $\Omega$
RX07	1	1	GD05152140	1.5K $\Omega$
RX08	1	1	GD05104140	100K $\Omega$
RX09	1	1	GD05103140	10K $\Omega$
RX10	1	1	GD05392140	3.9K $\Omega$
RX11	1	1	GD05392140	3.9K $\Omega$
RX12	1	1	GD05821140	820 $\Omega$
RX13	1	1	GD05821140	820 $\Omega$
RX14	1	1	GD05152140	1.5K $\Omega$
RX15	1	1	GD05152140	1.5K $\Omega$
RX16	1	1	GD05152140	1.5K $\Omega$
RX17	1	1	GD05102140	1K $\Omega$
RX18	1	1	GD05222140	2.2K $\Omega$
QX01	1	1	HC10003320	<b>PX00-SEMICONDUCTORS</b> IC IR2E11
QX02	1	1	HD20001210	Diode 1S2473
QX03	1	1	HI10007320	L.E.D. GL-9PR9, Red
QX04	1	1	HI10007320	L.E.D. GL-9PR9, Red
QX05	1	1	HI10007320	L.E.D. GL-9PR9, Red
QX06	1	1	HI10007320	L.E.D. GL-9PR9, Red
QX07	1	1	HI10006320	L.E.D. GL-9NG9, Green
QX08	1	1	HI10006320	L.E.D. GL-9NG9, Green
QX09	1	1	HI10007320	L.E.D. GL-9PR9, Red
QX10	1	1	HI10007320	L.E.D. GL-9PR9, Red
WX01	1	1	YU05240260	<b>PX00-MISCELLANEOUS</b> Jumper Lead, (5P) 240mm
WX02	1	1	YU05240260	Jumper Lead, (5P) 240mm
P001	1	1	YF403H0010 ZZ403H0010	<b>P001-LED CIRCUIT BOARD</b> P.W. Board, LED P.W. Board Assembly
Q001	1	1	HI10014300	L.E.D.
(W01-99)	Assembly and Wiring			
(T01-99)	Adjustment			
(X01-00)	Correction			

## 8. TECHNICAL SPECIFICATIONS

### AUDIO SECTION

#### POWER OUTPUT PER CHANNEL

4 OHMS DIN	48W
4 OHMS RMS	33W
8 OHMS DIN	35W
8 OHMS RMS	30W
TOTAL HARMONIC DISTORTION AT RMS 8 OHMS	0.3%
DAMPING FACTOR 8 OHMS	30

#### Frequency Response

Phono (RIAA)	±1.0 dB
Aux (±1 dB)	20 Hz – 20 kHz

#### Signal-to-Noise Ratio

Phono	70 dB
Aux	90 dB

#### Input Terminals

Phono: Input Sensitivity/Impedance	2.7 mV/47 kohms
Aux: Input Sensitivity/Impedance	160 mV/20 kohms

### FM TUNER SECTION

Frequency Range	87.5 – 108 MHz
Usable Sensitivity	
DIN Mono (S/N 26 dB, 75 ohms)	1.5 µV
DIN Stereo (S/N 46 dB, 75 ohms)	25 µV
Alternate Channel Selectivity, 98 MHz	65 dB
Signal-to-Noise Ratio, 98 MHz	
Unweighted: Mono	65 dB
Stereo	50 dB
Weighted: Mono	70 dB
Stereo	65 dB

### MW TUNER SECTION

Frequency Range	525 – 1630 kHz
Usable Sensitivity (20 dB S/N 30% Mod., 1 MHz)	10 µV
Selectivity	25 dB

### LW TUNER SECTION

Frequency Range	150 – 350 kHz
Usable Sensitivity (20 dB S/N 30% 250 kHz)	100 µV

### GENERAL

Power Requirements	220V AC, 50 Hz
	(E and N versions are featuring an external voltage selector for use on other voltages. Other versions can be converted by a qualified technician to operate on 240V.)
Power Consumption at Rated Output, Both Channels Operating	160W
Dimensions	
Panel Width	416 mm
Panel Height	73 mm
Depth	302 mm
Weight	
Unit alone	6 kg

Specifications and appearance are subject to change for modification without notice.

**MEMORANDUM**

9. SCHEMATIC DIAGRAM

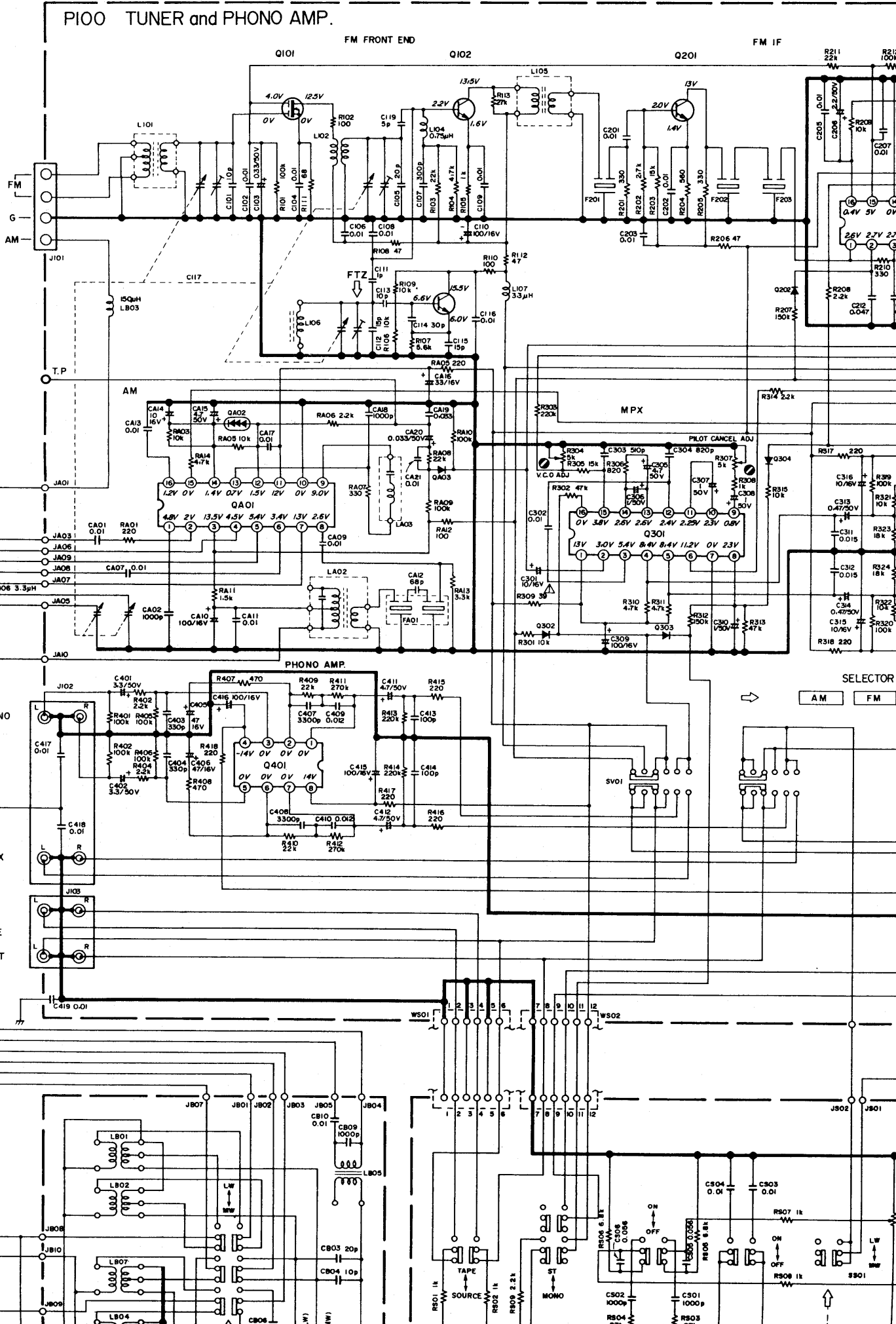

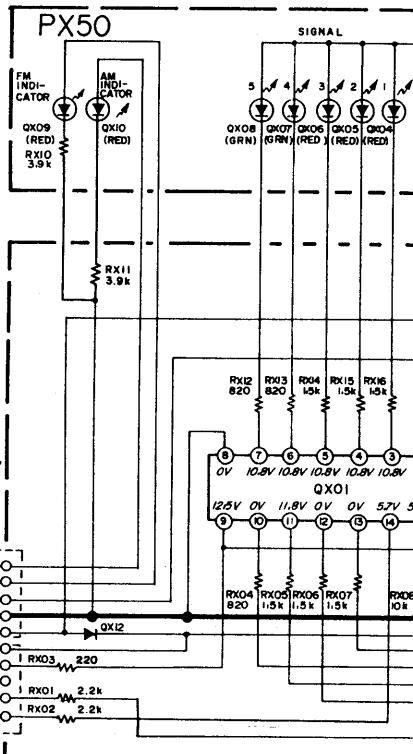
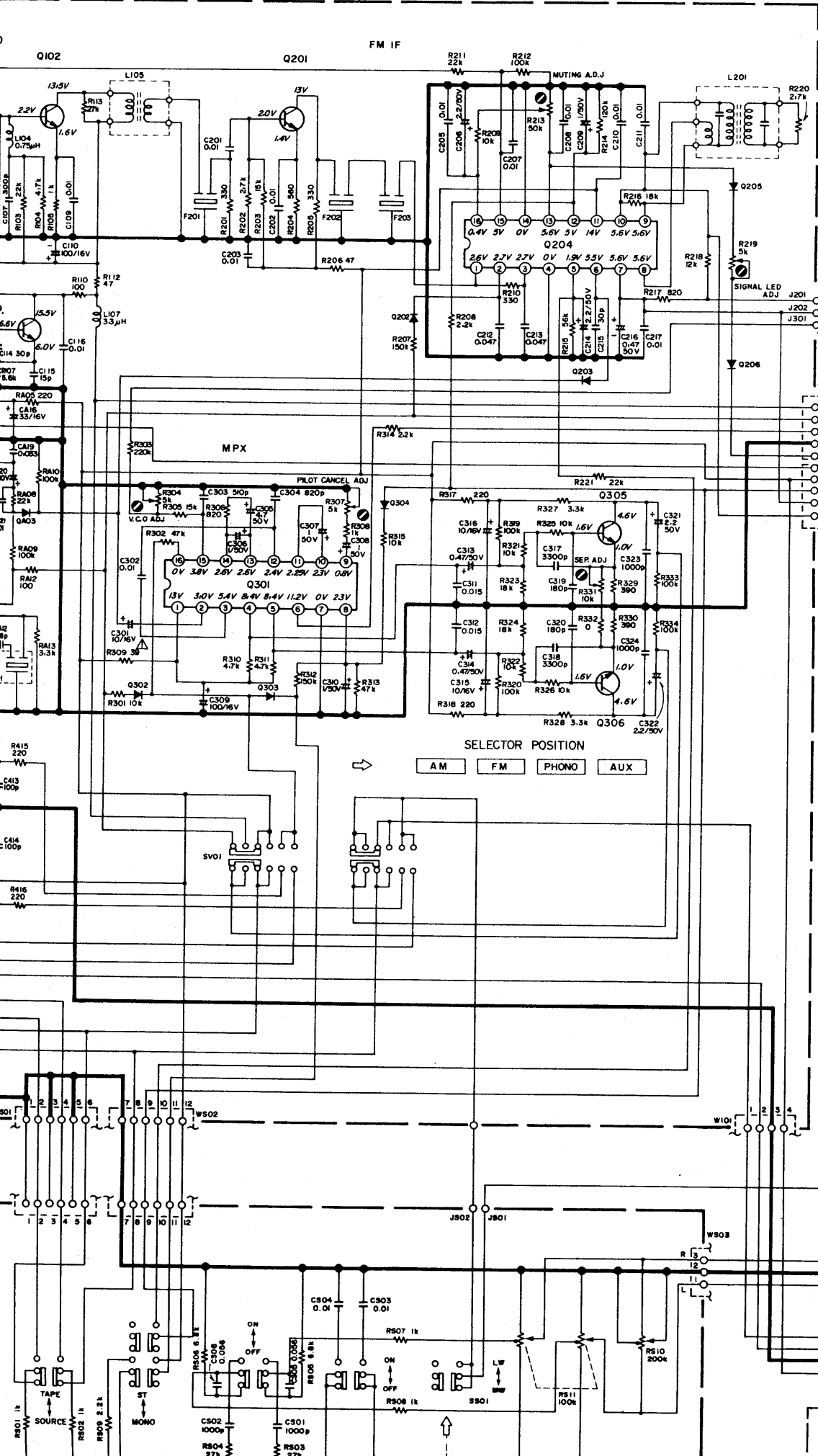

PX00 SIGNAL and TUNING LED

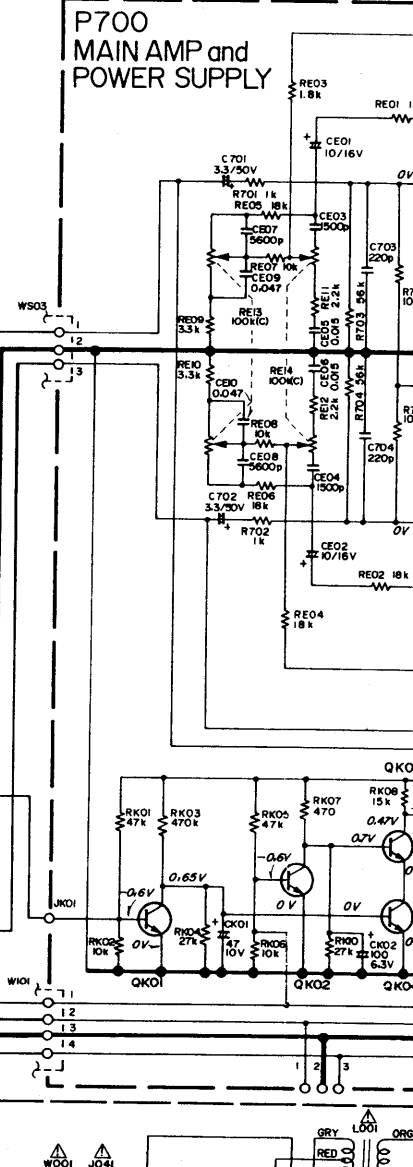

# Model SR1100L

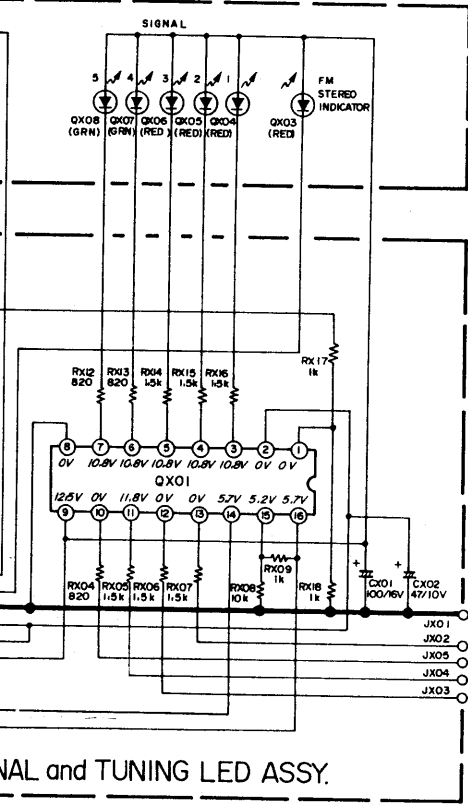

Q101 HF400451B0 3SK45B	Q401 HC10003090 4558D	Q717, Q719~Q722 HD20015030 DS 135D	Q601 HC10003090 4558D	QX03~QX06, QX09, QX10 HI 10007320 GL-9 PR9 (RED)
Q102 HT314071C0 2SC1047 (C)	Q701~Q704 HT107502A0 2SA750 (EorF)	Q718 HD30047090 WZ 192	QK01~QK06 HT309452A0 2SC945 (QorR)	QX07, QX08 HI 10006320 GL-9PG9 (GRN)
Q103, Q201 HT308291C0 2SC829 (C)	Q705, Q706 HT315092C0 2SC1509 (Ror S)	Q723, Q724 HT314001E0 2SC1400(E)	QK07 HD30027090 WZ140	
Q204 HC10028030 LA1231	Q707, Q708 HV00006120 MV203	Q801~Q804 HD20015030 S2V-20	QN01, QN02 HT309452A0 2SC945(QorR)	
Q205, Q206 HD20001210 IS2473	Q709, Q710 HT315092C0 2SC1509 (Ror S)	Q805~Q807 HD20015030 DS 135D	QN03, QN04 HT107332A0 2SA733 (QorR)	
Q301 HC10001420 KB4437	Q711, Q712 HT107772C0 2SA777 (Ror S)	Q808 HT40313100 2SD313 (E)	QN05~QN12 HD20001210 IS2473	
Q302~Q304 HD20001210 IS2473	Q713, Q714 HT326652B0 2SC2665 (OorY)	Q809, Q810 HD30027090 WZ140	QX01 HC10003320 IR2E11	
Q305, Q306 HT309452A0 2SC945 (QorR)	Q715, Q716 HT111352B0 2SA1135 (OorY)	QA01 HC10041030 LA1240	QX02 HD20001210 IS2473	

NO MARKING RESISTOR ; OHM, 1/4W  
NO MARKING CAPACITOR ; μF, 50V

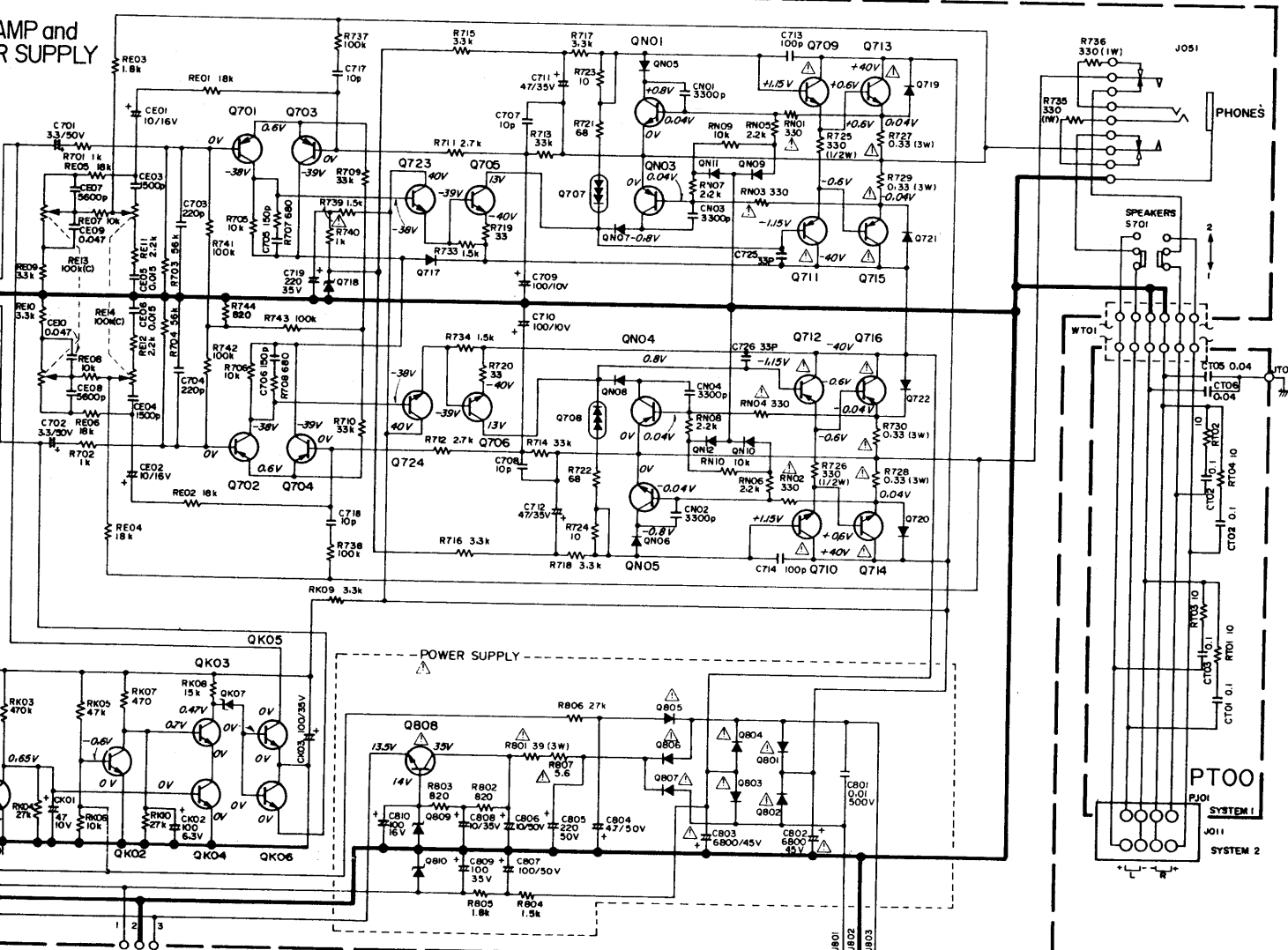
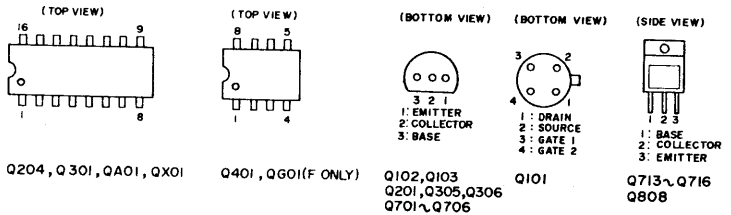

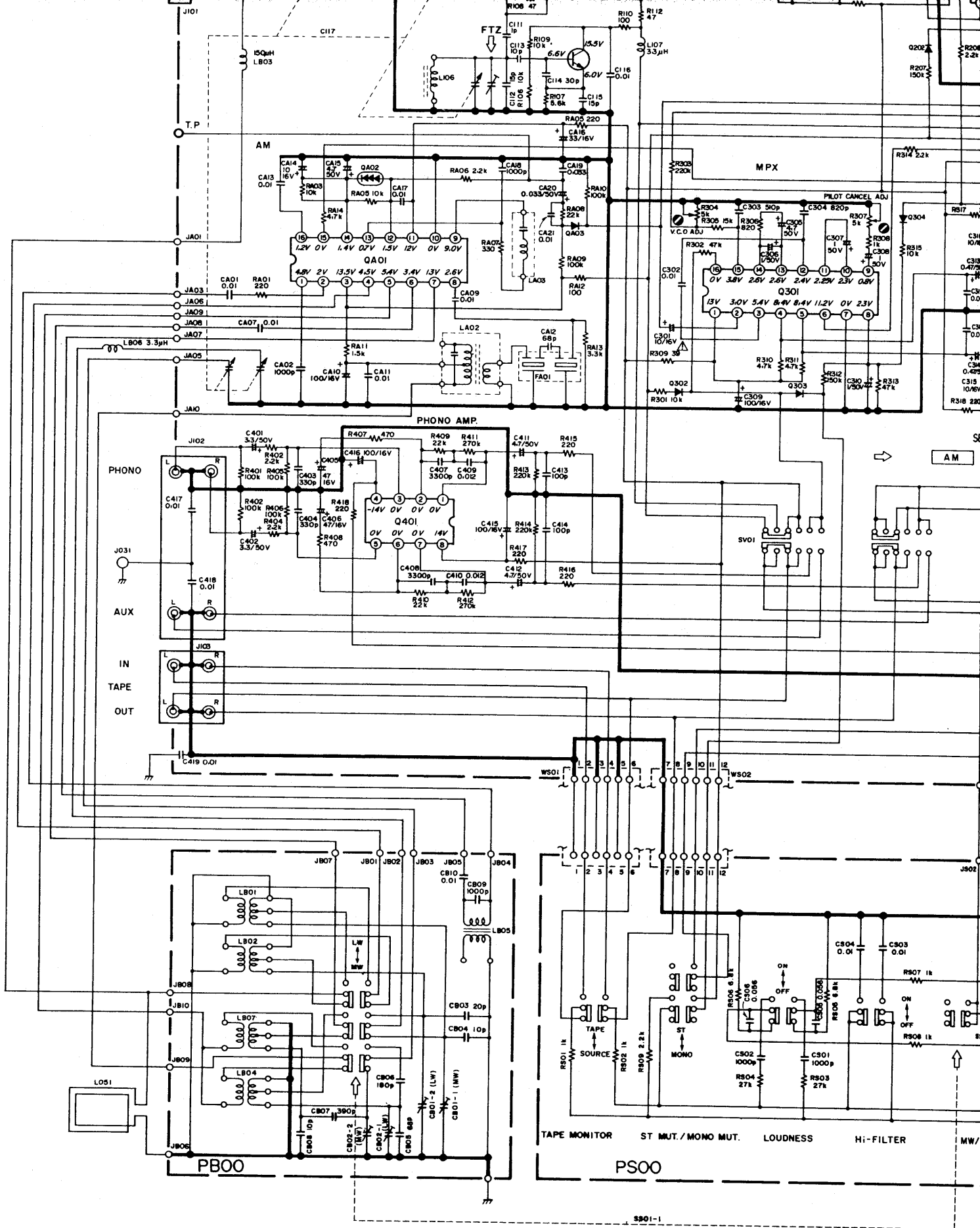

Note on safety: The parts marked with  $\Delta$  are important parts on the safety. Please use the parts having the designated parts number without fail.



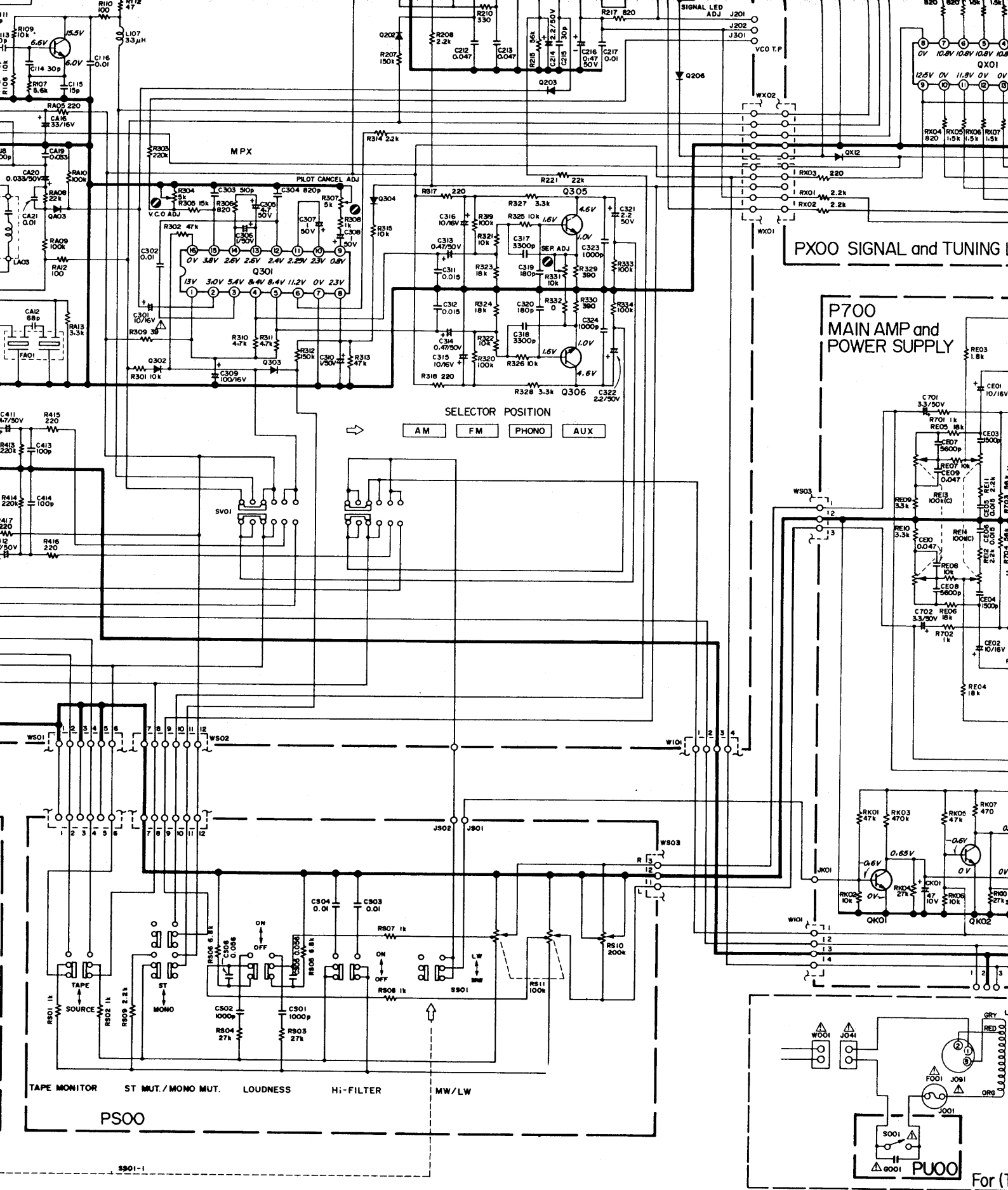

Important  
 the parts  
 number

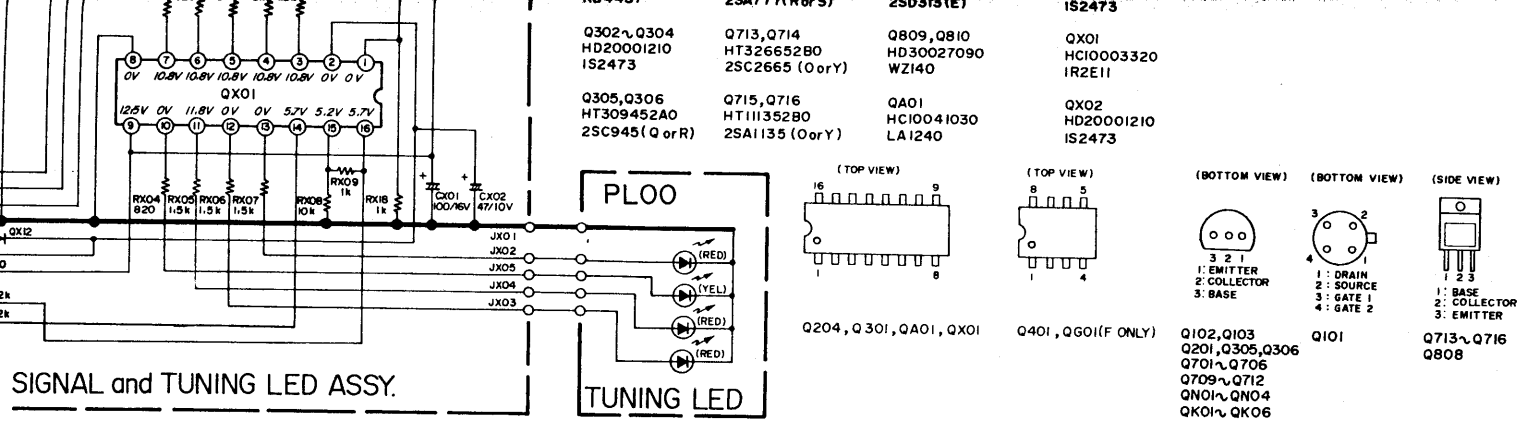

**700 MAIN AMP and POWER SUPPLY**

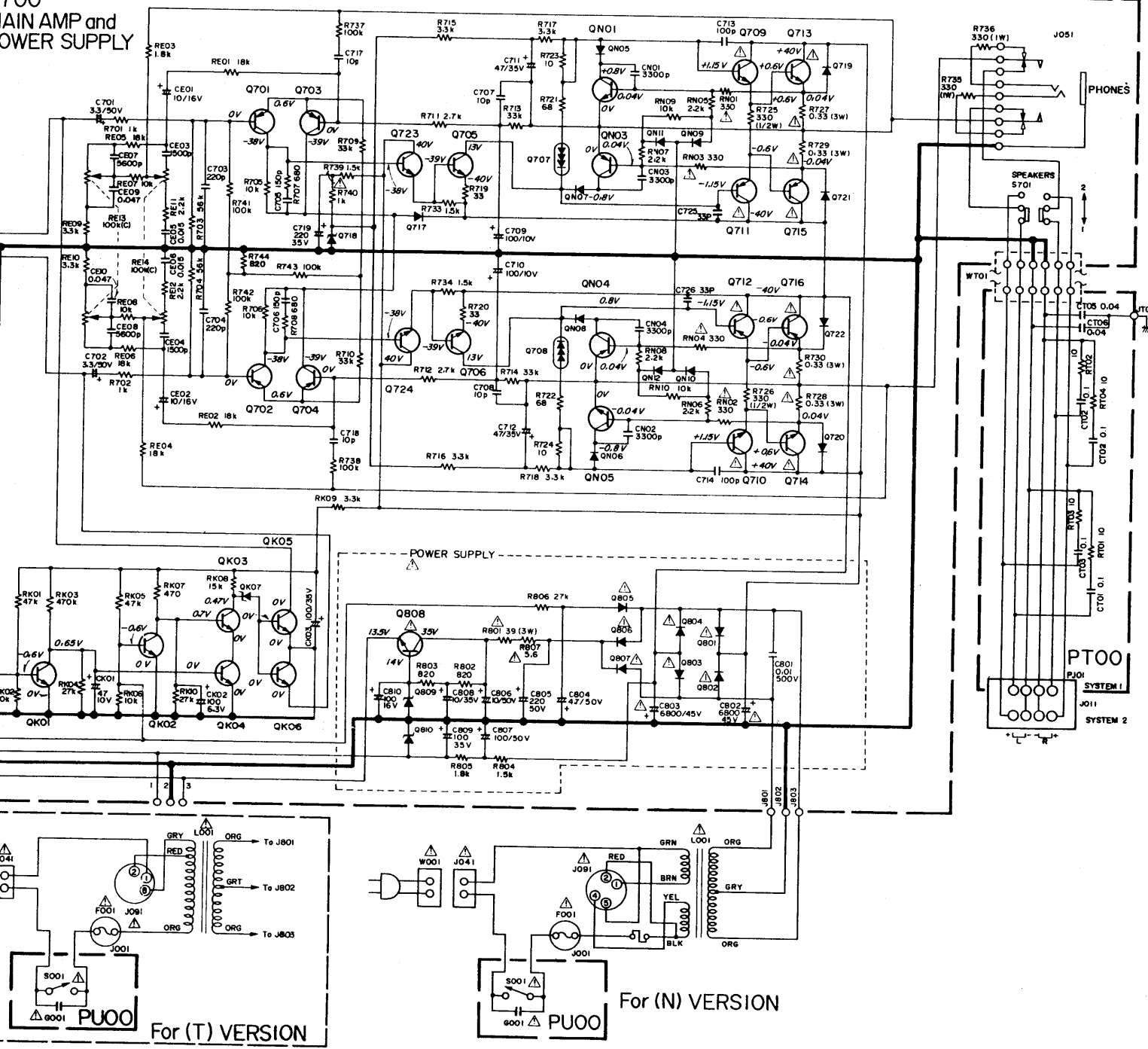

Components and wiring are subject to change for modification without notice.

V1800



**marantz®**