

# Service Manual

SR4120/U1B

Receiver

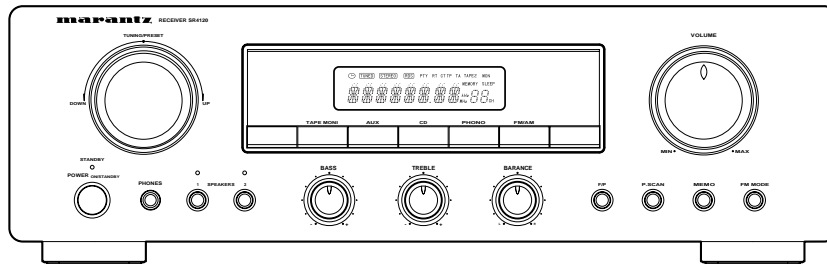

## TABLE OF CONTENTS

1.	TECHNICAL SPECIFICATION .....	1
2.	WIRING DIAGRAM .....	2
3.	BLOCK DIAGRAM .....	3
4.	SCHEMATIC DIAGRAM AND PARTS LOCATION .....	5
5.	MICROPROCESSOR AND IC DATA .....	16
6.	ADJUSTMENT PROCEDURE .....	18
7.	EXPLODED VIEW AND PARTS LIST .....	21
8.	ELECTRICAL PARTS LIST .....	23

Please use this service manual with referring to the user guide (D.F.U) without fail.

# marantz®

## SR4120

## MARANTZ DESIGN AND SERVICE

Using superior design and selected high grade components, **MARANTZ** company has created the ultimate in stereo sound. Only original **MARANTZ** parts can insure that your **MARANTZ** product will continue to perform to the specifications for which it is famous.

Parts for your **MARANTZ** equipment are generally available to our National Marantz Subsidiary or Agent.

### ORDERING PARTS :

Parts can be ordered either by mail or by Fax.. In both cases, the correct part number has to be specified.

The following information must be supplied to eliminate delays in processing your order :

1. Complete address
2. Complete part numbers and quantities required
3. Description of parts
4. Model number for which part is required
5. Way of shipment
6. Signature : any order form or Fax. must be signed, otherwise such part order will be considered as null and void.

#### USA

**MARANTZ AMERICA, INC.**  
440 MEDINAH ROAD  
ROSELLE, ILLINOIS 60172  
USA  
PHONE : 630 - 307 - 3100  
FAX : 630 - 307 - 2687

#### EUROPE / TRADING

**MARANTZ EUROPE B.V.**  
P.O.BOX 80002, BUILDING SFF2  
5600 JB EINDHOVEN  
THE NETHERLANDS  
PHONE : +31 - 40 - 2732241  
FAX : +31 - 40 - 2735578

#### BRAZIL

**PHILIP DA AMAZONIA IND. ELET. ITDA**  
CENTRO DE INFORMACOES AO  
CEP 04698-970  
SAO PAULO, SP, BRAZIL  
PHONE : 0800 - 123123(Discagem Direta Gratuita)  
FAX : +55 11 534. 8988

#### PROFESSIONAL AMERICAS

**SUPERSCOPE TECHNOLOGIES, INC.**  
MARANTZ PROFESSIONAL PRODUCTS  
2640 WHITE OAK CIRCLE, SUITE A  
AURORA, ILLINOIS 60504 USA  
PHONE : 630 - 820 - 4800  
FAX : 630 - 820 - 8103

#### PROFESSIONAL AUSTRALIA

**TECHNICAL AUDIO GROUP PTY, LTD**  
558 DARLING STREET,  
BALMAIN, NSW 2041,  
AUSTRALIA  
PHONE : 61 - 2 - 9810 - 5300  
FAX : 61 - 2 - 9810 - 5355

#### CANADA

**LENBROOK INDUSTRIES LIMITED**  
633 GRANITE COURT,  
PICKERING, ONTARIO L1W 3K1  
CANADA  
PHONE : 905 - 831 - 6333  
FAX : 905 - 831 - 6936

#### AUSTRALIA

**JAMO AUSTRALIA PTY LTD**  
1 EXPO COURT, P.O. BOX 350  
MT. WAVERLEY VIC 3149  
AUSTRALIA  
PHONE : +61 - 3 - 9543 - 1522  
FAX : +61 - 3 - 9543 - 3677

#### THAILAND

**MRZ STANDARD CO., LTD**  
746 - 754 MAHACHAI ROAD.,  
WANGBURAPAPIROM, PHRANAKORN,  
BANGKOK, 10200 THAILAND  
PHONE : +66 - 2 - 222 - 9181  
FAX : +66 - 2 - 224 - 6795

#### SINGAPORE

**WO KEE HONG (S) PTE LTD**  
WO KEE HONG CENTRE  
NO.23, LORONG 8, TOA PAYOH  
SINGAPORE 319257  
PHONE : +65 2544555  
FAX : +65 2502213

#### NEW ZEALAND

**WILDASH AUDIO SYSTEMS NZ**  
14 MALVERN ROAD MT ALBERT  
AUCKLAND NEW ZEALAND  
PHONE : +64 - 9 - 8451958  
FAX : +64 - 9 - 8463554

#### TAIWAN

**PAI- YUING CO., LTD.**  
6 TH FL NO, 148 SUNG KIANG ROAD,  
TAIPEI, 10429, TAIWAN R.O.C.  
PHONE : +886 - 2 - 25221304  
FAX : +886 - 2 - 25630415

#### MALAYSIA

**WO KEE HONG ELECTRONICS SDN. BHD.**  
SUITE 8.1, LEVEL 8, MENARA GENESIS,  
NO. 33, JALAN SULTAN ISMAIL,  
50250 KUALA LUMPUR, MALAYSIA  
PHONE : +60 3 - 2457677  
FAX : +60 3 - 2458180

#### JAPAN *Technical*

**MARANTZ JAPAN, INC.**  
35- 1, 7- CHOME, SAGAMIONO  
SAGAMIHARA - SHI, KANAGAWA  
JAPAN 228-8505  
PHONE : +81 42 748 1013  
FAX : +81 42 741 9190

#### 日本マランツ株式会社

本社 〒228-8505  
神奈川県相模原市相模大野7-35-1  
営業本部 〒150-0022  
東京都渋谷区恵比寿南1-11-9

#### KOREA

**MK ENTERPRISES LTD.**  
ROOM 604/605, ELECTRO-OFFICETEL, 16-58,  
3GA, HANGANG-RO, YONGSAN-KU, SEOUL  
KOREA  
PHONE : +822 - 3232 - 155  
FAX : +822 - 3232 - 154

### SHOCK, FIRE HAZARD SERVICE TEST :

**CAUTION :** After servicing this appliance and prior to returning to customer, measure the resistance between either primary AC cord connector pins ( with unit NOT connected to AC mains and its Power switch ON ), and the face or Front Panel of product and controls and chassis bottom.

Any resistance measurement less than 1 Megohms should cause unit to be repaired or corrected before AC power is applied, and verified before it is return to the user/customer.

Ref. UL Standard No. 1492.

In case of difficulties, do not hesitate to contact the Technical Department at above mentioned address.

# 1. TECHNICAL SPECIFICATIONS

## FM TUNER SECTION

FREQUENCY RANGE .....	87.5 - 108.0 MHz
USABLE SENSITIVITY .....	IHF 2.0 $\mu$ V/11.3 dBf
SIGNAL TO NOISE RATIO .....	MONO/STEREO 70/65 dB
DISTORTION .....	MONO/STEREO 0.3/0.5 %
STEREO SEPARATION .....	1 kHz 32 dB
A.C.S .....	$\pm$ 400 kHz 50 dB
IMAGE REJECTION .....	98 MHz 40 dB
TUNER OUTPUT LEVEL .....	1 kHz, $\pm$ 75 kHz Dev 600 mV

## AM TUNER SECTION

FREQUENCY RANGE .....	520 - 1710 kHz
USABLE SENSITIVITY .....	LOOP 500 $\mu$ V/m
SIGNAL TO NOISE RATIO .....	40 dB
DISTORTION .....	1 kHz, 30 % Mod. 1.0 %
SELECTIVITY .....	$\pm$ 10 kHz 25 dB

## AUDIO SECTION

RATED POWER .....	20 Hz - 20 kHz 8 ohms 60 W/Ch
THD .....	20 Hz - 20 kHz 8 ohms 0.09 %
INPUT SENSITIVITY/IMPEDANCE	
LINEAR .....	200 mV/47k ohms
SIGNAL TO NOISE RATIO (IHF-A)	
LINEAR .....	95 dB

## OTHERS

POWER SUPPLY .....	AC 120V 60 Hz
POWER CONSUMPTION .....	1.8 A

## DIMENSIONS (MAX)

WIDTH .....	17 - 5/16 inches (440 mm)
HEIGHT .....	5 - 3/8 inches (137 mm)
DEPTH .....	15 - 7/16 inches (392 mm)
WEIGHT .....	16.5 lbs(7.5kg)

Specifications subject to change without prior notice.

## 2. WIRING DIAGRAM

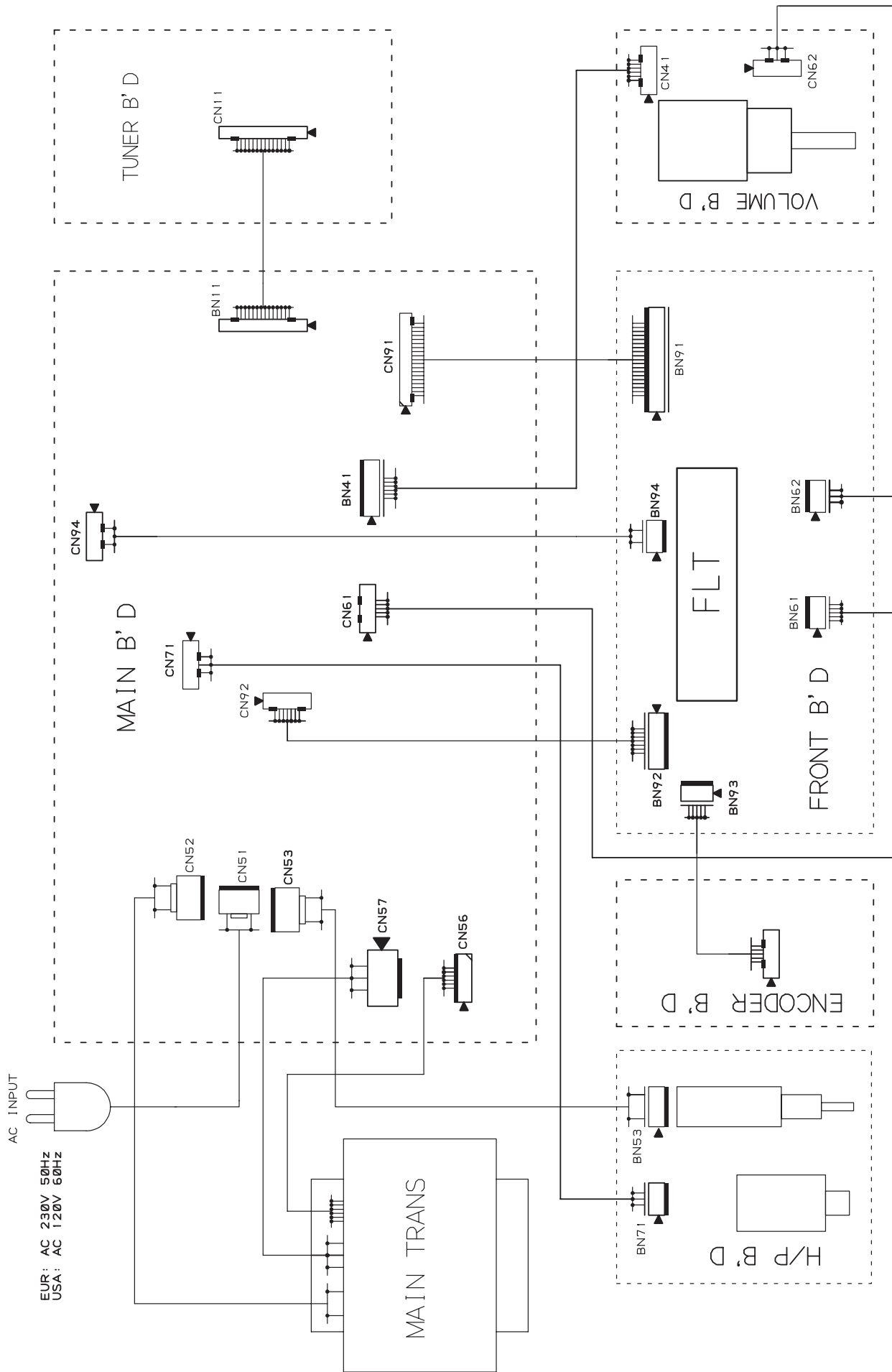

### 3. BLOCK DIAGRAM

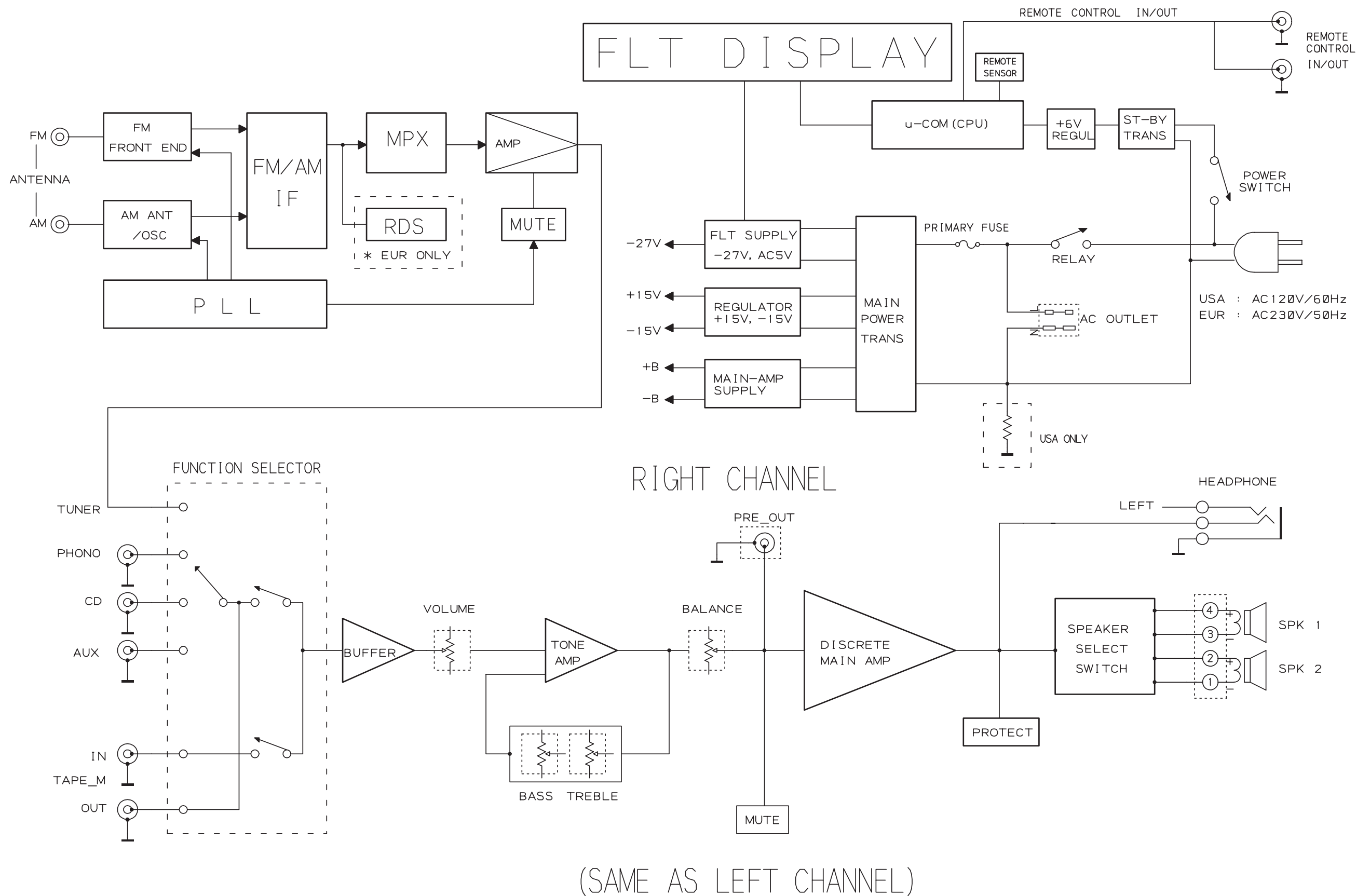

# 4. SCHEMATIC DIAGRAM AND PARTS LOCATIONS

## MAIN SCHEMATIC DIAGRAM

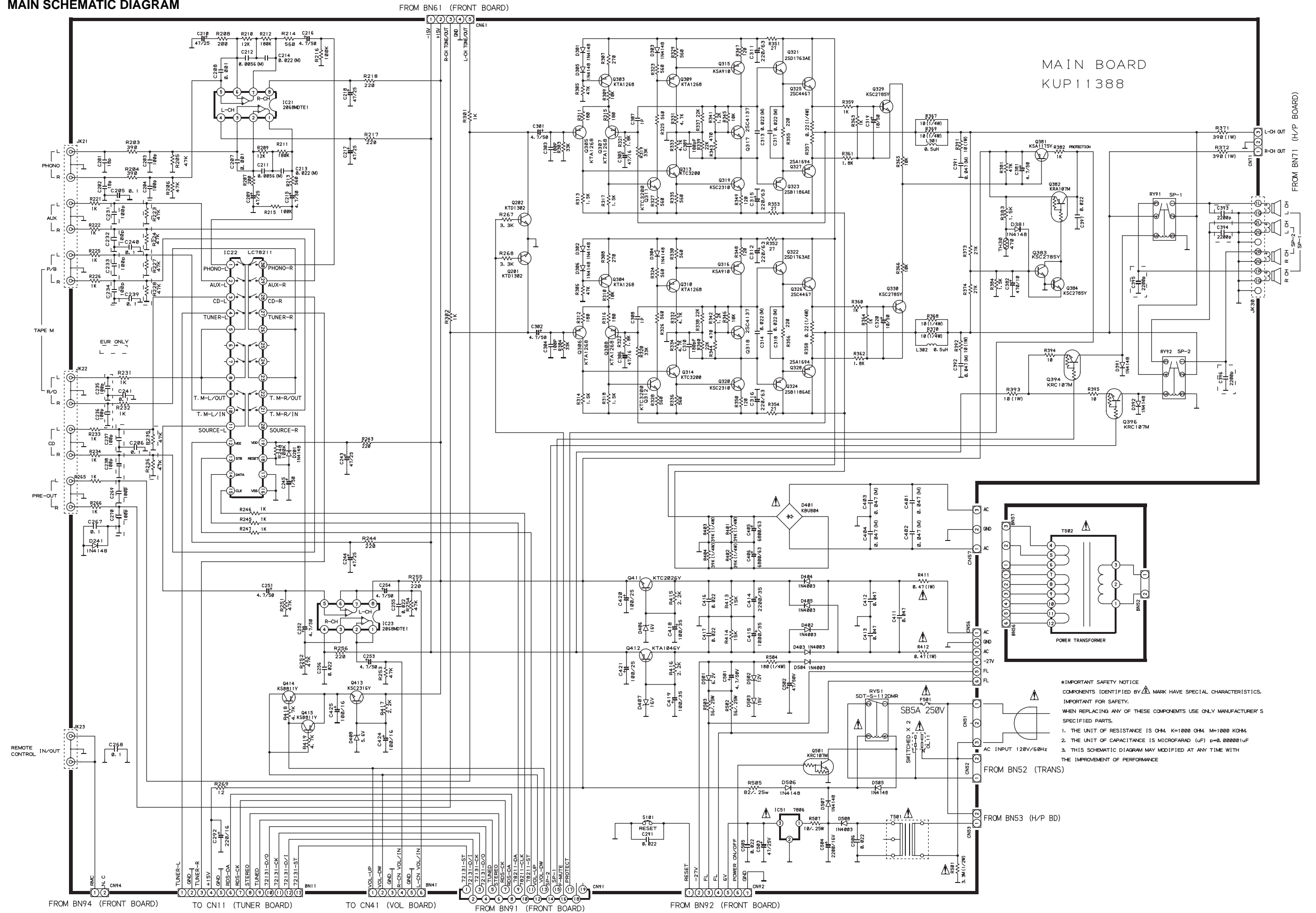

MAIN BOARD  
KUP11388

**\*IMPORTANT SAFETY NOTICE**  
COMPONENTS IDENTIFIED BY MARK HAVE SPECIAL CHARACTERISTICS. IMPORTANT FOR SAFETY. WHEN REPLACING ANY OF THESE COMPONENTS USE ONLY MANUFACTURER'S SPECIFIED PARTS.

1. THE UNIT OF RESISTANCE IS OHM. K=1000 OHM. M=1000 KOHM.
2. THE UNIT OF CAPACITANCE IS MICROFARAD (uF) u=0.000001UF
3. THIS SCHEMATIC DIAGRAM MAY MODIFIED AT ANY TIME WITH THE IMPROVEMENT OF PERFORMANCE

MAIN BOARD

IC51 Q501  
 Q411  
 Q412  
 Q329 Q381 Q382 Q385 Q384

Q394  
 Q303  
 Q315 Q309 Q307 Q311

Q396  
 Q305  
 Q319 Q313  
 Q330

Q202 Q201  
 IC22  
 IC23 Q312  
 Q304 Q308 Q314  
 Q316 Q310 Q320

IC21  
 Q413  
 Q415  
 Q414

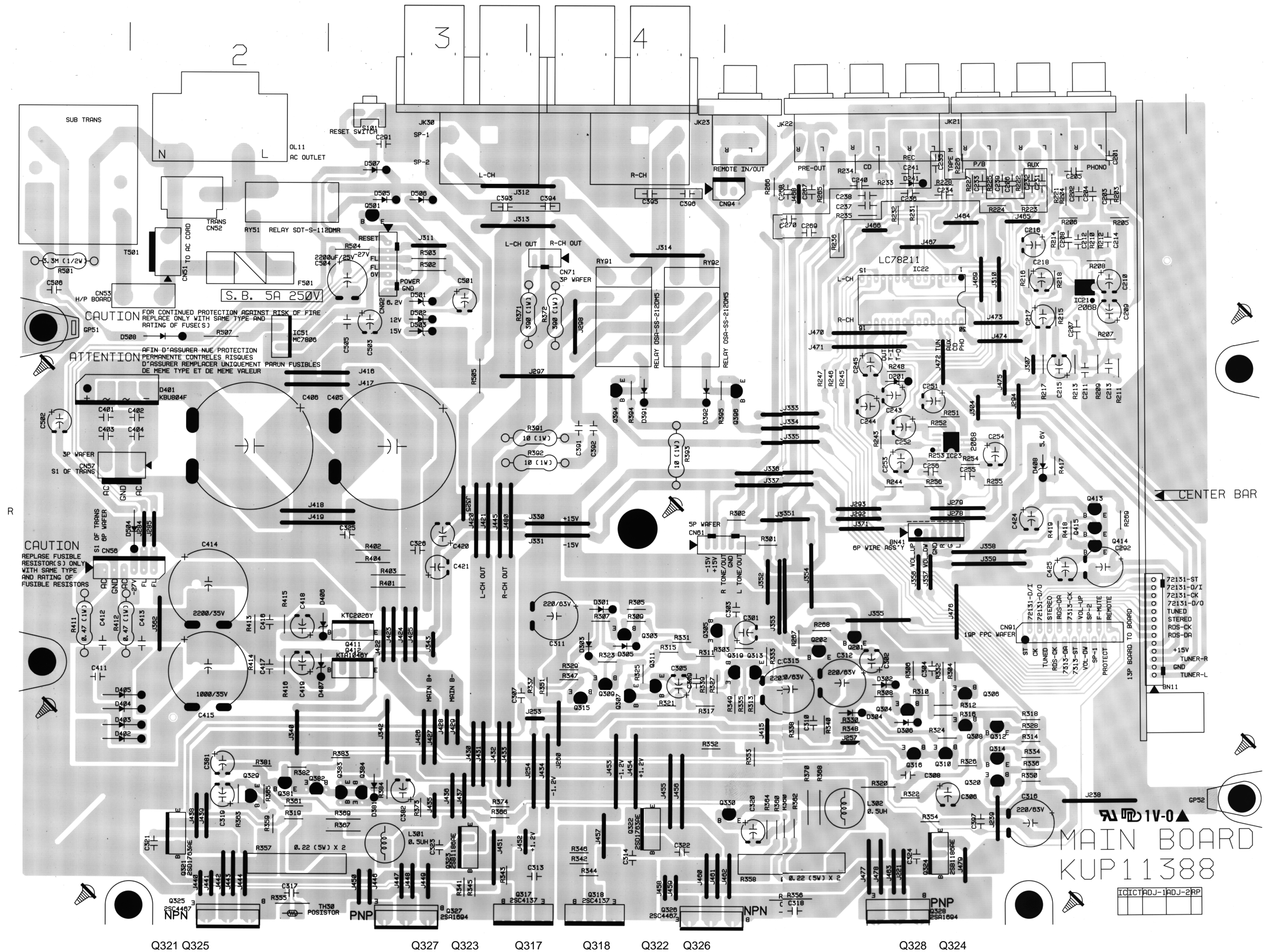

Q321 Q325

Q327 Q323

Q317

Q318

Q322

Q326

Q328

Q324

FRONT SCHEMATIC DIAGRAM

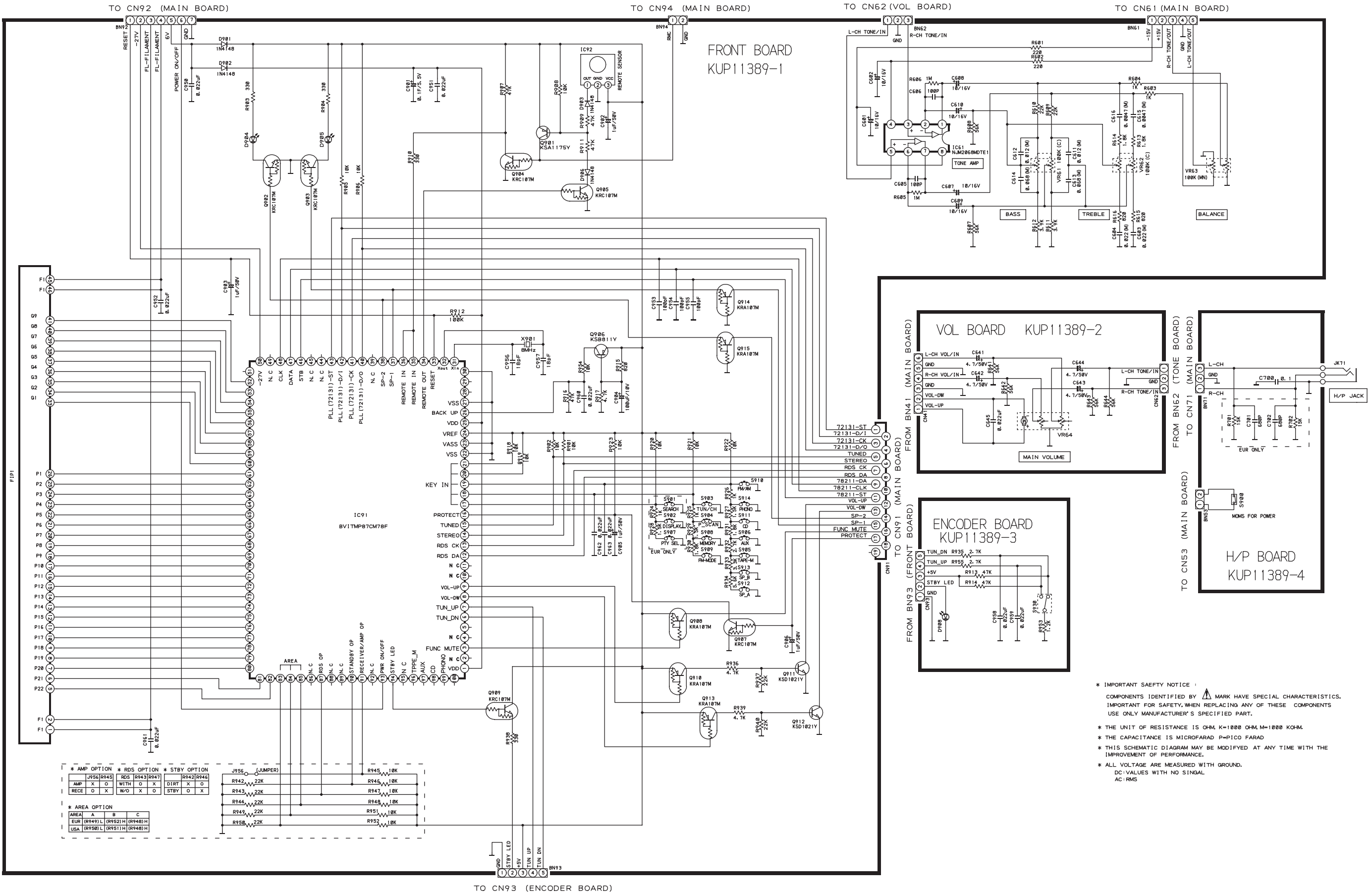

* AMP OPTION		* RDS OPTION		* STBY OPTION	
AMP	X	DIRT	X	DIRT	X
RECE	O	W/O	X	STBY	O

* AREA OPTION		
AREA	A	C
EUR	(R949) L (R952) H (R948) H	
USA	(R950) L (R951) H (R948) H	

**\* IMPORTANT SAFETY NOTICE :**  
 COMPONENTS IDENTIFIED BY MARK HAVE SPECIAL CHARACTERISTICS. IMPORTANT FOR SAFETY, WHEN REPLACING ANY OF THESE COMPONENTS USE ONLY MANUFACTURER'S SPECIFIED PART.

\* THE UNIT OF RESISTANCE IS OHM, K=1000 OHM, M=1000 KOHM.  
 \* THE CAPACITANCE IS MICROFARAD, P=PICO FARAD  
 \* THIS SCHEMATIC DIAGRAM MAY BE MODIFIED AT ANY TIME WITH THE IMPROVEMENT OF PERFORMANCE.  
 \* ALL VOLTAGE ARE MEASURED WITH GROUND.  
 DC: VALUES WITH NO SIGNAL  
 AC: RMS



FRONT BOARD

Q909 Q913  
 Q905 Q910 Q908  
 Q903 Q914 Q902

IC02 Q915 IC61 IC91

Q912 Q904  
 Q911 Q905 Q901 Q907

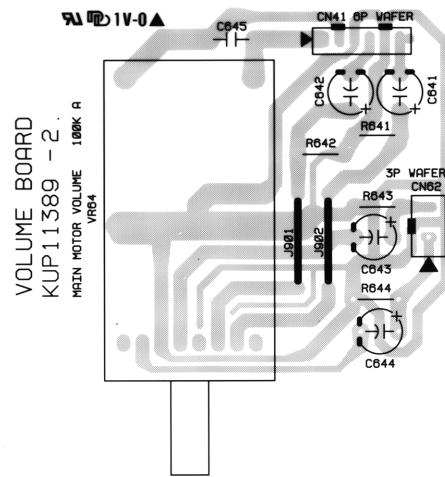
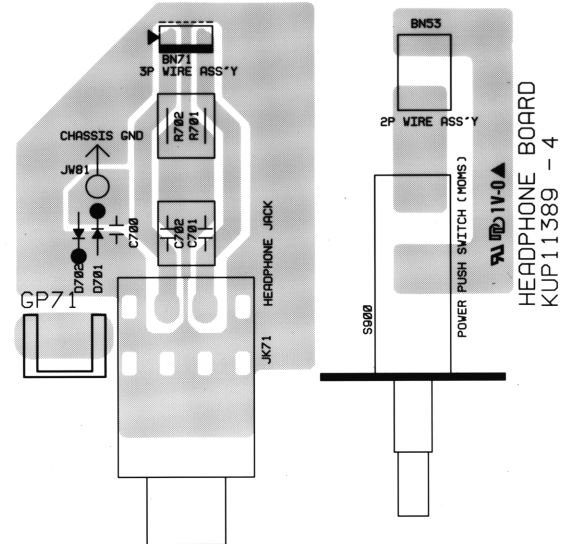
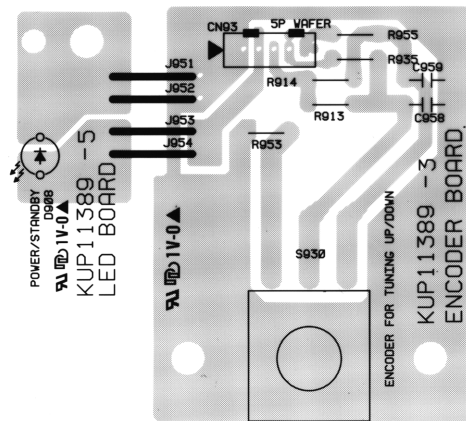
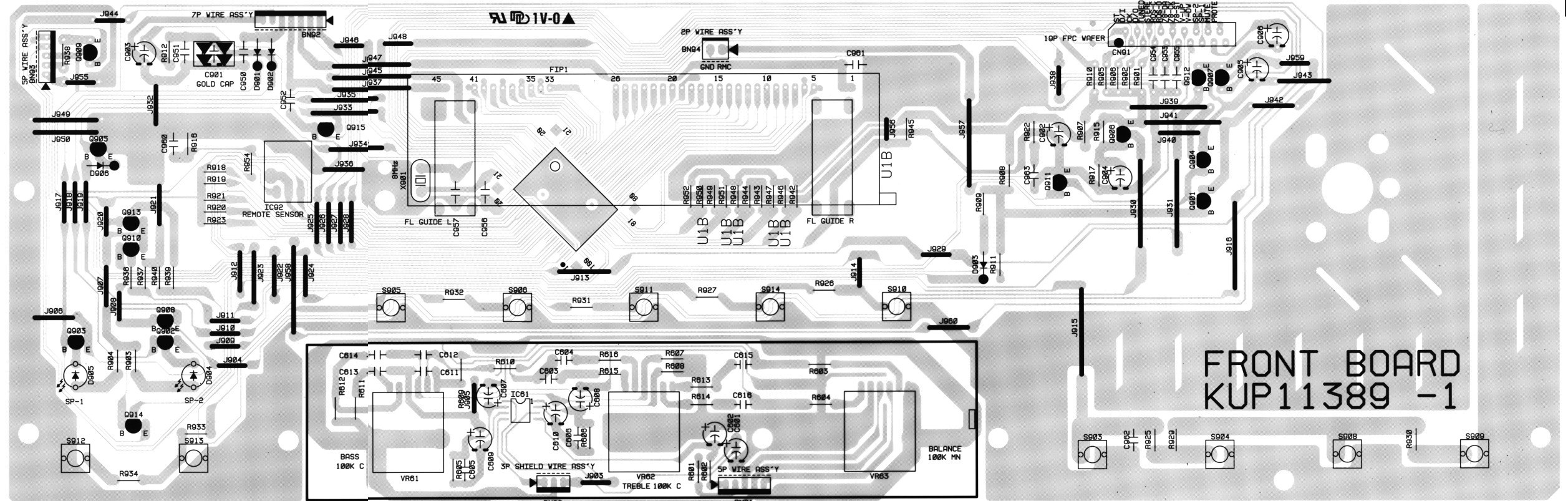

TUNER SCHEMATIC DIAGRAM

IC01: LA1266 (FM/AM)

NO.	VOLT	NO.	VOLT
1	2.5/1.0	13	STRQ
2	2.5/1.1	14	1.2/1.2
3	2.5/1.1	15	1.5/2.0
4	GND	16	1.5/0.6
5	12.1	17	0/1.2
6	12.1	18	2.5/2.0
7	12.1	19	1.5/1.6
8	0/5.0	20	0/1.2
9	3.9/3.9	21	4.0/3.7
10	FM IF	22	4.0/3.7
11	AM IF	23	4.0/3.7
12	3.1/3.1	24	3.1/2.3

IC02: LA3410 (ST/MO)

NO.	VOLT	NO.	VOLT
1	11.5	9	0.5/4.8
2	3.0	10	3.0/4.8
3	3.0	11	3.0
4	4.8	12	3.0
5	3.0	13	3.0
6	3.0	14	3.0
7	4.8	15	3.0
8	GND	16	3.5

IC03: NJM2068M

NO.	VOLT
1	14.0
2	7.0
3	7.0
4	7.0
5	GND
6	7.0
7	7.0
8	7.0
9	14.0

IC04: LC72131M (FM/AM)

NO.	VOLT	NO.	VOLT
1	7.2MHz	11	IF IN
2	CE	12	4.8
3	DATA I	13	AM OSC
4	CK	14	FM OSC
5	DATA O	15	4.8
6	NC	16	1.2
7	0/15	17	1.2
8	0/1.5	18	V.T
9	0/5.6	19	GND
10	NC	20	7.2MHz

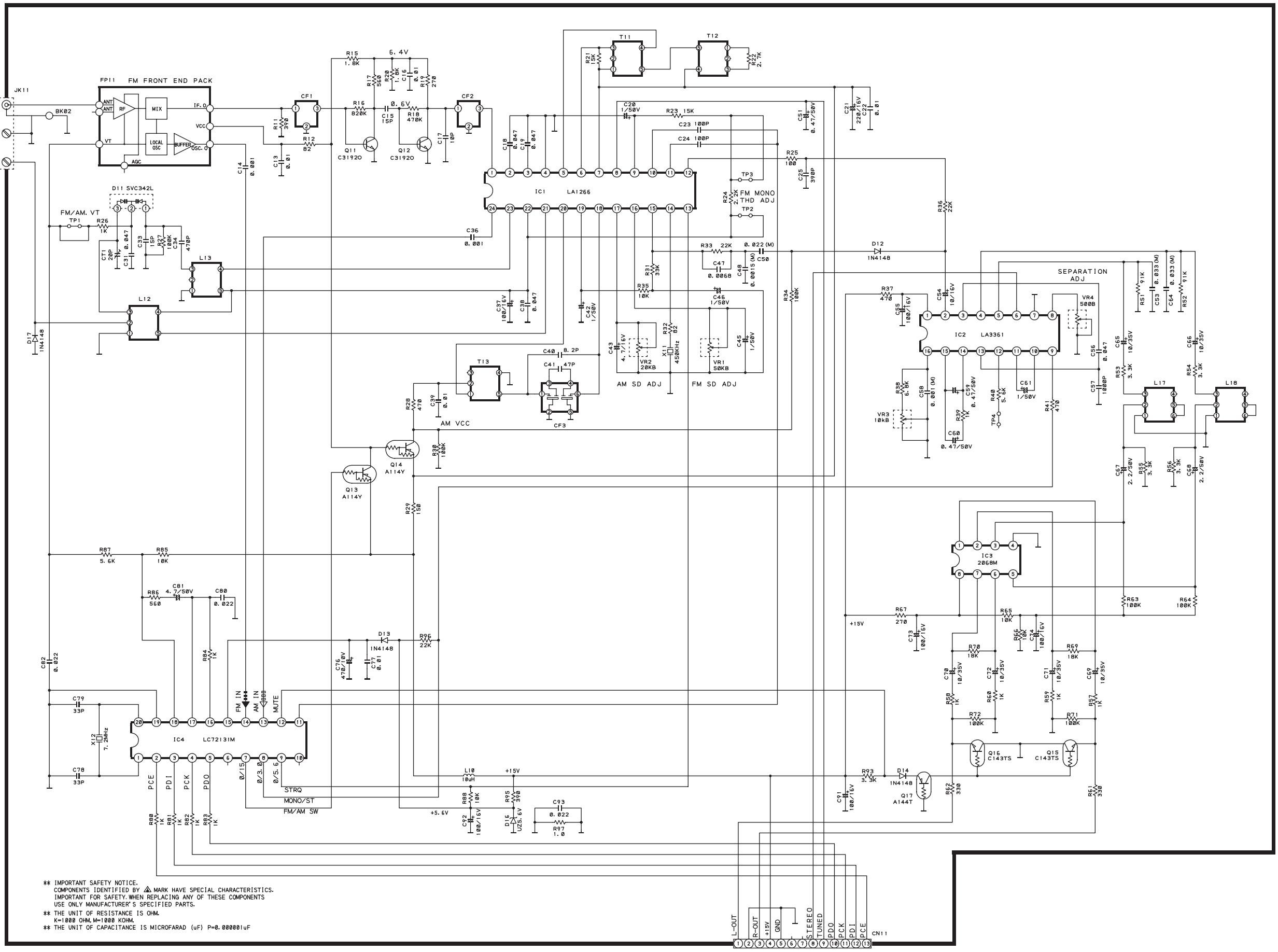

\*\* IMPORTANT SAFETY NOTICE.  
 COMPONENTS IDENTIFIED BY  $\Delta$  MARK HAVE SPECIAL CHARACTERISTICS.  
 IMPORTANT FOR SAFETY WHEN REPLACING ANY OF THESE COMPONENTS  
 USE ONLY MANUFACTURER'S SPECIFIED PARTS.  
 \*\* THE UNIT OF RESISTANCE IS OHM.  
 K=1000 OHM, M=1000 KOHM.  
 \*\* THE UNIT OF CAPACITANCE IS MICROFARAD ( $\mu$ F) P=0.000001 $\mu$ F

CN1

NO.	FUNCTION
1	L-OUT
2	R-OUT
3	+15V
4	GND
5	I
6	STEREO
7	TUNED
8	P.D.O
9	P.C.K
10	P.D.I
11	P.C.E
12	P.C.E
13	P.C.E

# TUNER BOARD

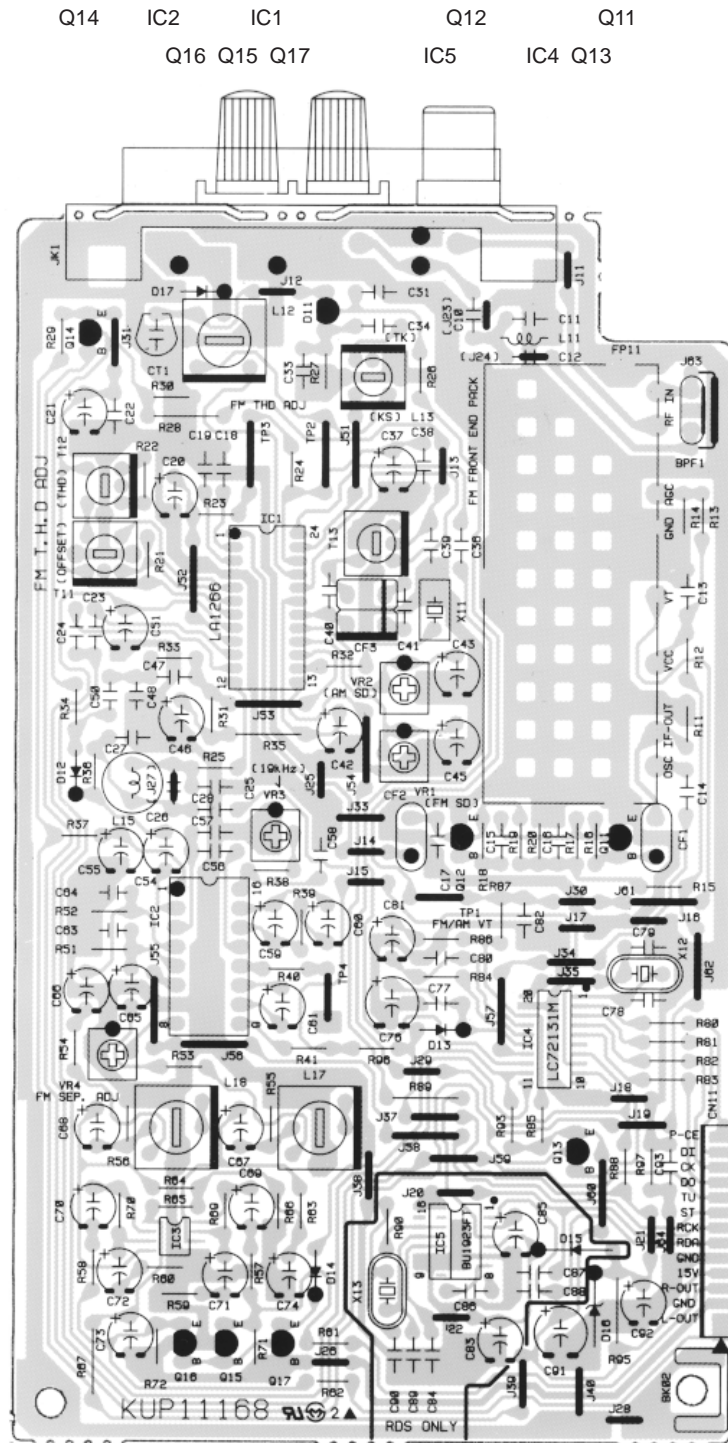

# 5. MICROPROCESSOR DESCRIPTIONS

## 1. Block Diagram

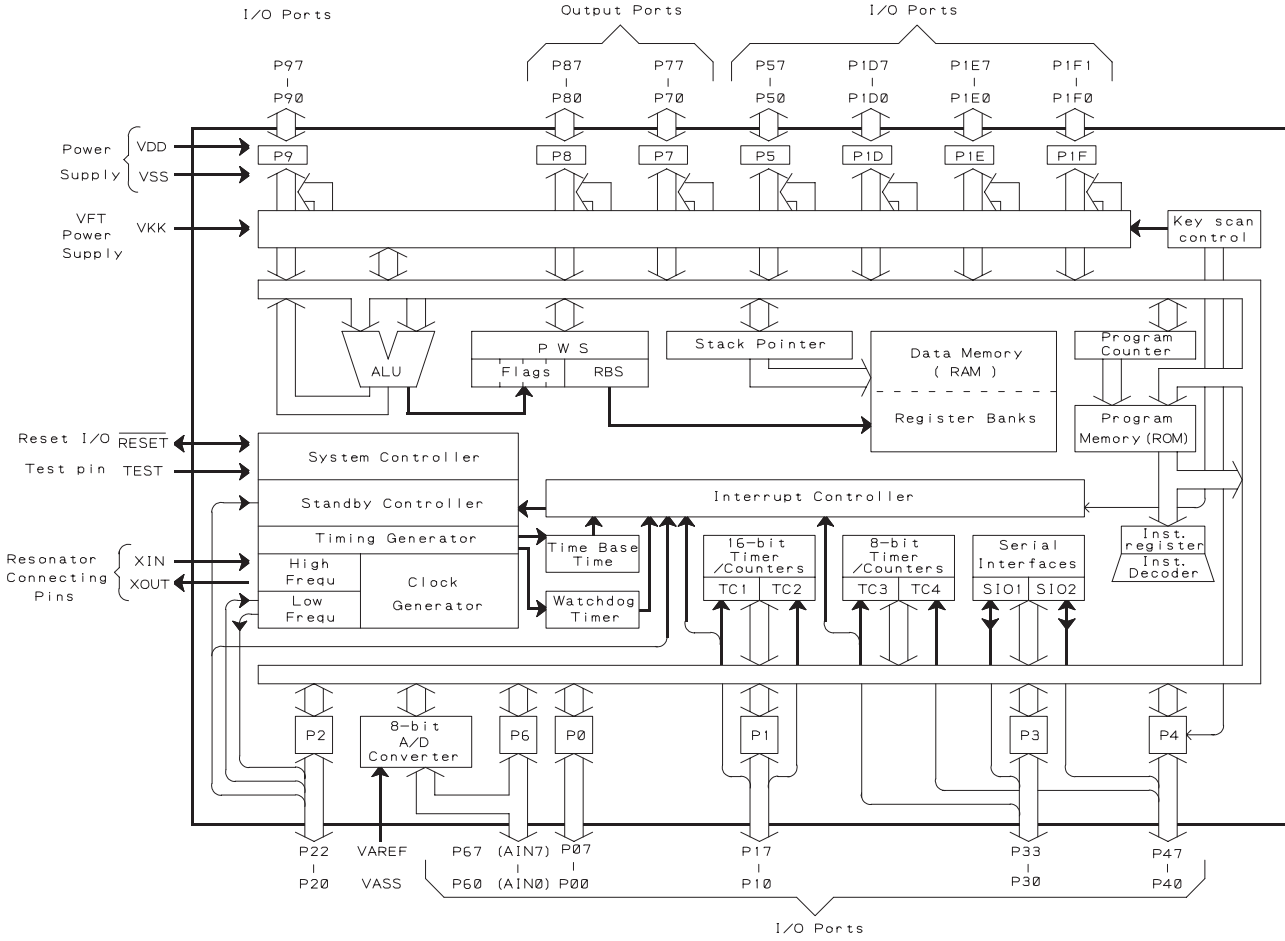

## 2. Pin Configuration

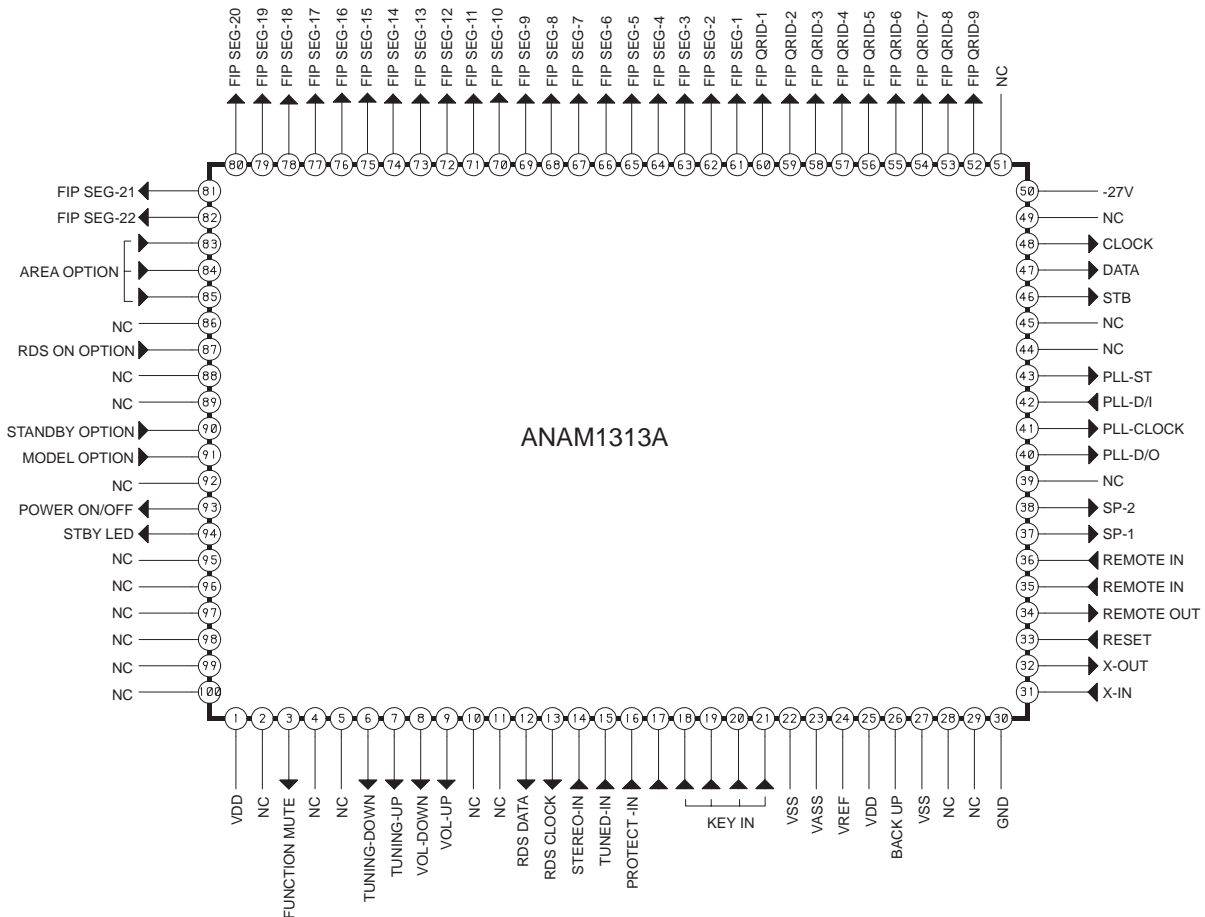

### 3. Pin Functions

PIN NO.	SYMBOL	DESCRIPTION
1	VDD	+5V POWER SUPPLY
2,4,5	N.C	NOT USED
3	FUNCTION MUTE	MUTING WHEN CHANGE THE FUNCTION BUTTON
6	TUNING DOWN	INPUT OF ENCODER FOR TUNING DOWN
7	TUNING UP	INPUT ENCODER TUNING UP
8	VOLUME DOWN	OUTPUT TO CONTROL MOTOR VOLUME DOWN
9	VOLUME UP	OUTPUT TO CONTROL MOTOR VOLUME UP
10,11	N.C	NOT USED
12	RDS DATA	TUNER RDS DATA OUTPUT
13	RDS CLOCK	TUNER RDS CLOCK OUTPUT
14	STEREO-IN	INPUT FOR DETECTING FM STEREO, ACTIVE LOW (0V)
15	TUNED-IN	INPUT FOR DETECTING THE STATION IS DURING TUNING WHEN THE STATION IS DETECTED, ACTIVE LOW (0V)
16	PROTECT-IN	SIGNAL INPUT FOR PROTECTION, ACTIVE LOW (0V)
17~21	KEY-IN	DATA INPUT FOR KEY SCAN
22,27	VSS	GROUND
23	VASS	GROUND
24	VREF	VOLTAGE FOR REFERENCE
25	VDD	+5V POWER SUPPLY
26	BACK UP	IF PORT IS LOW, POWER IS OFFED AND LAST MOMERY IS ACTIVATED.
28,29	N.C	NOT USED
30	GND	GROUND
31	X-IN	INPUT FOR CRYSTAL OSCILATOR
32	X-OUT	OUTPUT FOR CRYSTAL OSCILATOR
33	RESET	OUTPUT FOR SETTING CPU, ACTIVE LOW (0V)
34	REMOTE-OUT	OUTPUT FOR REMOTE CONTROL DATA
35,36	REMOTE-IN	INPUT FOR REMOTE CONTROL DATA
37	SP-1	SWITING THE SPEAKER SYSTEM-1 OUTPUT
38	SP-2	SWITING THE SPEAKER SYSTEM-2 OUTPUT
39	N.C	NOT USED
40	PLL D/O	TUNER PLL IC (LC72131M) DATA-OUT PORT
41	PLL CLOCK	TUNER PLL IC (LC72131M) CLOCK PORT
42	PLL D/I	TUNER PLL IC (LC72131M) DATA-IN PORT
43	PLL ST	TUNER PLL IC (LC72131M) CHIP ENABLE PORT
44,45	N.C	NOT USED
46	STB	STROBE PORT FOR FUNCTION SWITCHING IC (LC78211)
47	DATA	DATA PORT FOR FUNCTION SWITCHING IC (LC78211)
48	CLOCK	CLOCK PORT FOR FUNCTION SWITCHING IC (LC78211)
49,51	NC	NOT USED
50	-27V	-27V POWER SUPPLY FOR FIP
52~60	FIP GRID	PORTS FOR FIP GRID
61~82	FIP SEGMENT	PORTS FOR FIP SEGMENT
83	OPTION	AREA OPTION ("H" IS EUROPE, "L" IS USA)
84	OPTION	AREA OPTION ("L" IS EUROPE, "H" IS USA)
85	OPTION	AREA OPTION ("H" IS EUROPE, USA "L" IS EXCEPT)
86	N.C	NOT USED
87	OPTION	RDS OPTION ("L" IS RDS ON, "H" IS RDS OFF)
88~90	N.C	NOT USED
91	OPTION	STANDBY OPTION ("L" IS STANDBY, "H" IS POWER ON DIRECTLY)
92	OPTION	MODEL OPTION ("L" IS RECEIVER, "H" IS AMP)
93	POWER ON/OFF	WHEN THE POWER IS HIGH (5V), UNIT IS OPERATE
94	STANDBY LED	INDICATING DURING THE STANDBY MODE, ACTIVE HIGH (5V)
95~100	N.C	NOT USED

## Key Matrix

I/O	—	1 kohm	1.5 kohm	1.8 kohm	2.7 kohm	3.3 kohm
PIN17	SEARCH	DISPLAY	PTY SELECT	—	—	—
PIN18	TUN/CH MODE	P. SCAN	MEMORY	FM MODE	TUNED-DN	TUNED-UP
PIN19	—	TAPE-MONI	AUX	FM/AM	CD	PHONO
PIN20	—	—	—	—	—	—
PIN21	—	—	—	—	—	—

## 6.MEASUREMENTS AND ADJUSTMENTS

### ALIGNMENT INSTRUCTIONS

#### Equipment needed:

- AM Standard Signal Generator
- FM Standard Signal Generator
- Oscilloscope
- VTVM (AC, DC)
- AM Test Loop Antenna (AM Adjustment)
- FM Dummy Antenna (FM Adjustment)
- Stereo Signal Generator (RDS IN : EUROPE ONLY)
- Frequency Counter
- Distortion Analyser

#### IMPORTANT

1. Check power-source voltage.
2. Set the function switch to band aligned.
3. Keep the signal input as low as possible to adjust accurately.
4. Modulation and Modulation frequency.

Item	Modulation	Modulation frequency
Band		
AM	30 %	400 Hz
FM	MONO: 75 kHz DEV. (100 %)	1 kHz
	STEREO: L=R (67.5 kHz), PILOT (7.5 kHz)	

### TUNER ADJUSTMENT POINT

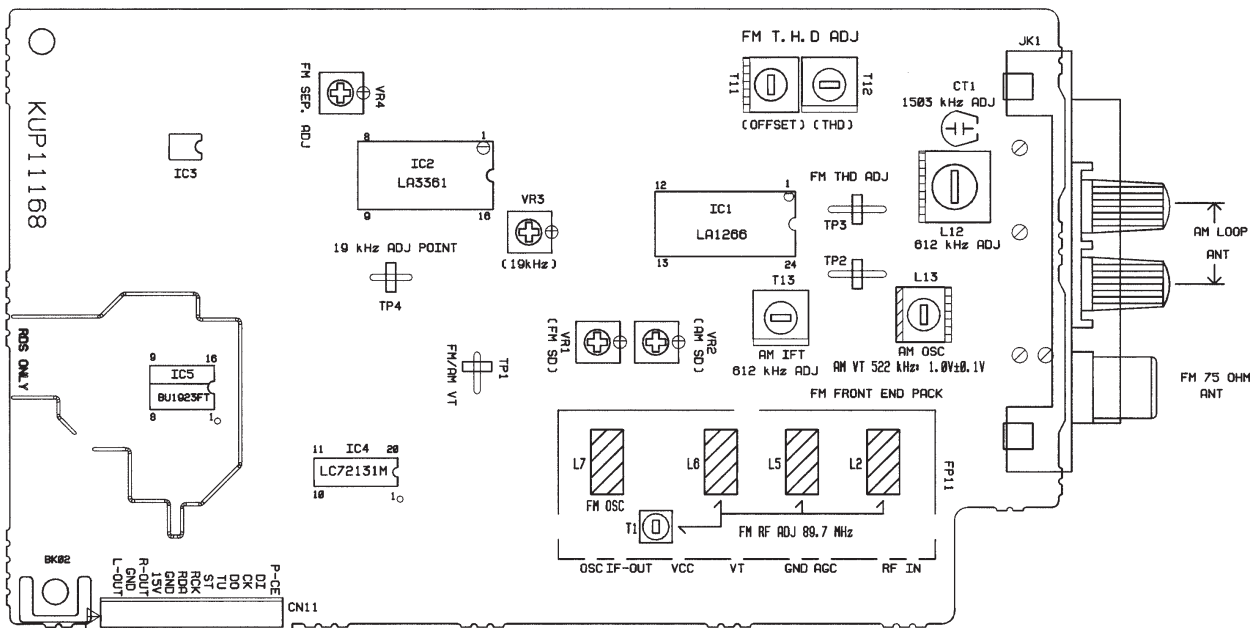

**(1) FM, AM TRACKING VOLTAGE ADJUSTMENT**

AM, FM DC Voltmeter -- Connect to test point TP1 and GND

No	Band	Frequency	Adjust for	Adjustment
1	FM	87.50 MHz	1.6 V	L7
2	AM	522 kHz	1.0 V	L13
	AM	530 kHz	1.0 V	L13

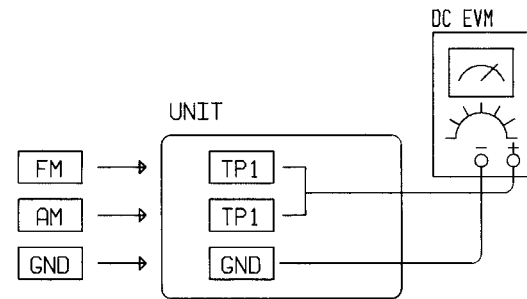

**(2) AM RF ADJUSTMENT**

Signal Generator ---- Connect to the AM Ant. Coil through the loop antenna.

Adjust for indication of VTVM of the wave form of scope to be maximum.

Band	Step	Frequency	Adjust for	Adjustment
AM	1	610 kHz	Maximum sens.	L12, T13
	2	1510 kHz	Maximum sens.	CT1
	3	Repeat steps 1 and 2 several times		

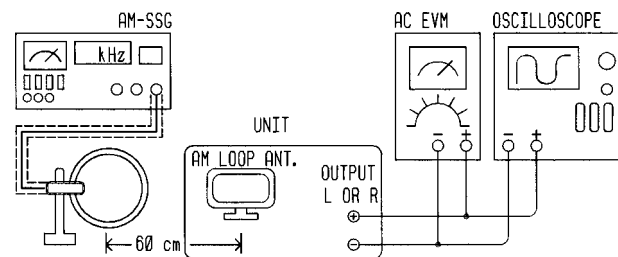

**(3) FM RF ADJUSTMENT**

Signal Generator ---- Connect to FM Ant. (FM 75 ohm) through the dummy.

Adjust for indication of VTVM of the wave form of scope to be maximum.

Band	Step	Frequency	Adjust for	Adjustment
FM	1	90.10 MHz	Maximum sens.	L2, L5, L6, T1
	2	Repeat step 1 several times		

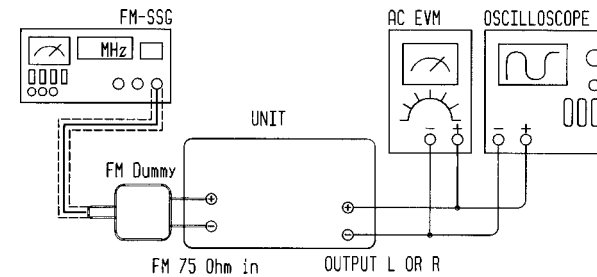

**(4) FM MONO DISTORTION ADJUSTMENT**

Signal Generator ---- Connect to FM Ant. (FM 75 ohm) through the dummy.

DC Voltmeter ---- Connect to TP2(+), TP3(-) through the choke coil (100mH)

Distortion Meter ----- Connect to output L or R

Band	Step	Frequency	Adjust for	Adjustment
FM	1	100.50 MHz	DC Volt 0V	T11
	2	100.50 MHz	Minimum T.H.D	T12
	3	Repeat steps 1 and 2 several times		

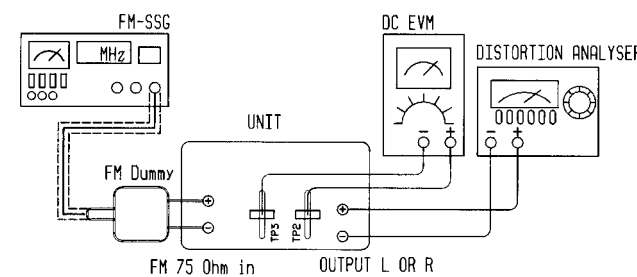

**(5) FM MPX VCO ADJUSTMENT**

Signal Generator ---- Connect to FM Ant. (FM 75 ohm) through the dummy.

Band	Frequency	SSG Condition	Adjust for	Adjustment
FM	100.50 MHz	Modulation ----- 0 %	19.00 kHz + 30 Hz	VR3
		Modulation Frequency ---- 0 Hz		
		Output Level ----- 66 dB		

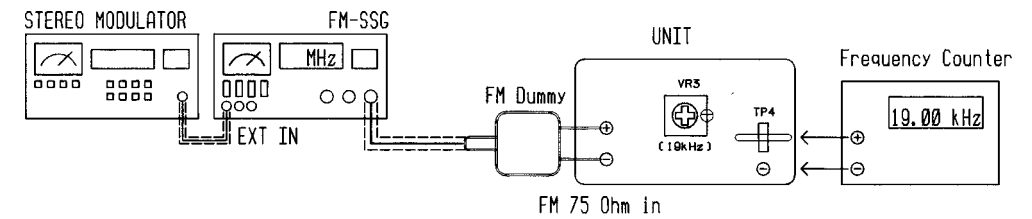

**(6) FM STEREO SEPARATION ADJUSTMENT**

Signal Generator ---- Connect to FM Ant. (FM 75 ohm) through the dummy.

Band	Frequency	SSG Condition	Adjust for	Adjustment
FM	100.50 MHz	Modulation ----- L or R only	Different of R or L must be maximum	VR4
		Modulation Frequency ---- 1 kHz		
		Output Level ----- 66 dB		

NOTE: In case of adjusting the stereo separation of input is L(or R) channel, R(or L) channel must be maximum.

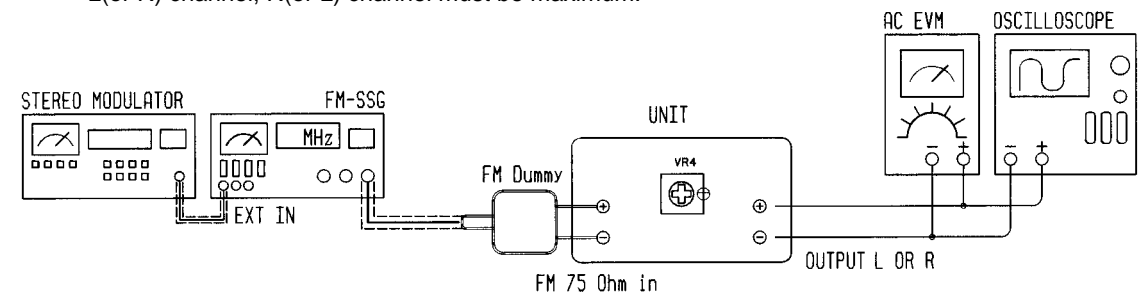

**(7) AM, FM AUTO STOP LEVEL ADJUSTMENT**

Signal Generator ---- Connect to FM Ant. (FM 75 ohm) through the dummy.  
 ---- Connect to the AM Ant. Coil through the loop antenna.

Band	Step	Frequency and Level	Adjust for	Adjustment
FM	1	100.50 MHz, 30 dB	TUNED Display off	VR1
	2	100.50 MHz, 30 dB	TUNED Display on	VR1
AM	1	990 kHz, 80 dB	TUNED Display off	VR2
	2	990 kHz, 80 dB	TUNED Display on	VR2

## 7. EXPLODED VIEW AND PARTS LIST

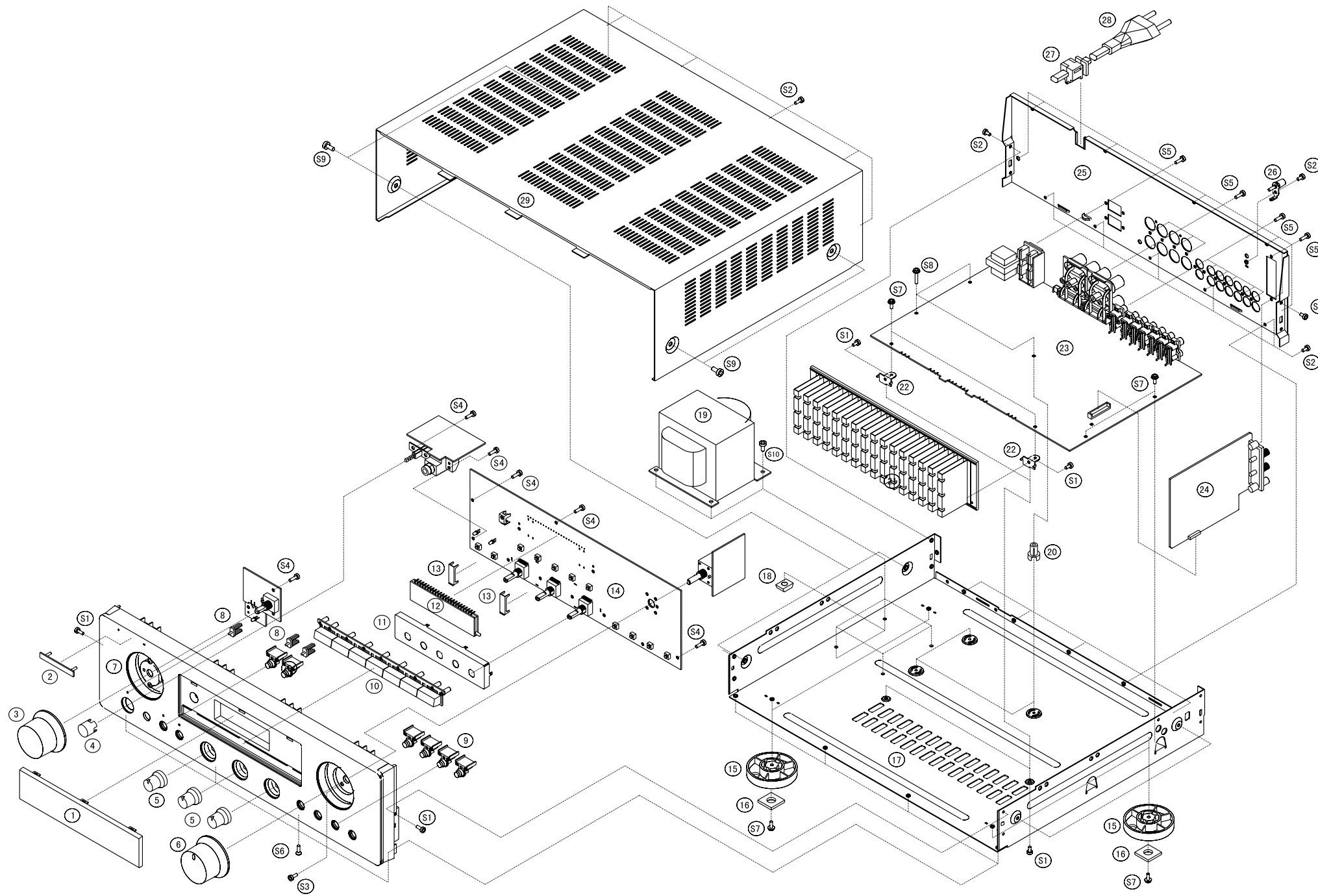

POS. NO	VERS. COLOR	PART NO. (PCS)	DESCRIPTION	PART NO. (MJ)
1			WINDOW FL DISPLAY	309W158010
2			BADGE MARANTZ	185J251012
3			KNOB TUNING/PRESET	285W154010
4			KNOB POWER	285W270010
5			KNOB BALANCE	274W154030
6			KNOB VOLUME	309W154010
7			PANEL FRONT	309W248010
8			INDICATOR MUTE	274W355010
9			KNOB BAND	282W270040
10			KNOB TACT	309W270010
11			COVER SHIELD	nsp
12			FL DISPLAY	*HQ300350R
13			BRACKET FLT	nsp
14			FRONT PCB ASS'Y	nsp
15			FOOT	243W057010
16			RUBBER CUSHION	nsp
17			CHASSIS BOTTOM	nsp
18			RUBBER	nsp
▲ 19			MAIN TRANSFORMER	*TS001230R
20			HOLDER PCB	nsp
21			HEAT SINK	nsp
22			BRACKET PCB	nsp
23			MAIN PCB ASS'Y	nsp
24			TUNER PCB ASS'Y	nsp
25			PANEL REAR	nsp
26			TERMINAL GROUND	nsp
27			BUSHING MAINS CORD	nsp
▲ 28			MAINS CORD	*YC000500R
S1			SCREW	nsp
S2			SCREW	nsp
S3			SCREW	nsp
S4			SCREW	nsp
S5			SCREW	nsp
S6			SCREW	nsp
S7			SCREW	nsp
S8			SCREW	nsp
S9			SCREW	nsp
S10			SCREW TRANS	nsp



## 9. ELECTRICAL PARTS LIST

### ASSIGNMENT OF COMMON PARTS CODES.

#### RESISTORS

R\*\*\* : 1) GD05 x x x 140, Carbon film fixed resistor, ±5% 1/4W  
 R\*\*\* : 2) GD05 x x x 160, Carbon film fixed resistor, ±5% 1/6W  
 ① Resistance value

Examples

① Resistance value  
 0.1Ω ..... 001    10Ω ..... 100    1kΩ ..... 102    100kΩ ..... 104  
 0.5Ω ..... 005    18Ω ..... 180    2.7kΩ ..... 272    680kΩ ..... 684  
 1Ω ..... 010    100Ω ..... 101    10kΩ ..... 103    1MΩ ..... 105  
 6.8Ω ..... 068    390Ω ..... 391    22kΩ ..... 223    4.7MΩ ..... 475

**Note** : Please distinguish 1/4W from 1/6W by the shape of parts used actually.

#### CAPACITORS

C\*\*\* : CERAMIC CAP.

3) DD1 x x x x 370, Ceramic capacitor  
 Disc type  
 Temp. coeff. P350~N1000, 50V  
 ③ Capacity value  
 ② Tolerance

Examples

② Tolerance (Capacity deviation)

±0.25 pF ..... 0  
 ±0.5 pF ..... 1  
 ±5 % ..... 5

Tolerance of COMMON PARTS handled here are as follows :

0.5 pF - 5 pF ..... ± 0.25 pF  
 6 pF - 10 pF ..... ± 0.5 pF  
 12 pF - 560 pF ... ± 5 %

③ Capacity value

0.5 pF .... 005    3 pF ..... 030    100 pF ..... 101  
 1 pF .... 010    10 pF ..... 100    220 pF ..... 221  
 1.5 pF .... 015    47 pF ..... 470    560 pF ..... 561

C\*\*\* : CERAMIC CAP.

4) DK16 x x x 300, High dielectric constant ceramic capacitor  
 Disc type  
 Temp. chara. 2B4, 50V  
 ④ Capacity value

Examples

④ Capacity value

100 pF ..... 101    1000 pF .... 102    10000 pF .... 103  
 470 pF ..... 471    2200 pF .... 222

C\*\*\* : 5) ELECTROLY CAP. (  ), 6) FILM CAP (  )

5) EA x x x x x 10, Electrolytic capacitor  
 One-way lead type, Tolerance ±20%  
 ⑥ Working voltage  
 ⑤ Capacity value

Examples

⑤ Capacity value

0.1 μF .... 104    4.7 μF .... 475    100 μF ..... 107  
 0.33 μF .... 334    10 μF .... 106    330 μF ..... 337  
 1 μF .... 105    22 μF .... 226    1100 μF ..... 118  
 2200 μF .... 228

⑥ Working voltage

6.3 V ..... 006    25 V ..... 025  
 10 V ..... 010    35 V ..... 035  
 16 V ..... 016    50 V ..... 050

6) DF15 x x x 350 → Plastic film capacitor  
 DF15 x x x 310 → One-way type, Mylar ±5% 50V  
 DF16 x x x 310 → Plastic film capacitor  
 One-way type, Mylar ±10% 50V  
 ⑦ Capacity value

Examples

⑦ Capacity value

0.001 μF (1000 pF) ..... 102    0.1 μF ..... 104  
 0.0018 μF ..... 182    0.56 μF ..... 564  
 0.01 μF ..... 103    1 μF ..... 105  
 0.015 μF ..... 153

**NOTE** 1) The above CODES (R\*\*\*, R\*\*\*, C\*\*\*, C\*\*\* and C\*\*\*) are omitted on the schematic diagram in some case.  
 2) On the occasion, be confirmed the common parts on the parts list.  
 3) Refer to "Common Parts List" for the other common parts (R105, DD4, DK4).

### NOTE ON SAFETY FOR FUSIBLE RESISTOR :

The suppliers and their type numbers of fusible resistors are as follows ;

1. KOA Corporation

Part No.(MJI)	Type No.(KOA)	Description
NH05 x x x 140	RF25S x x x x Ω	J ±5% (1/4W)
NH05 x x x 120	RF50S x x x x Ω	J ±5% (1/2W)
NH85 x x x 110	RF73B2A x x x x Ω	J ±5% (1/10W)
NH95 x x x 140	RF73B2E x x x x Ω	J ±5% (1/4W)

\* Resistance value

Resistance value(0.1Ω - 10kΩ)

2. Matsushita Electronic Components Co., Ltd

Part No.(MJI)	Type No.(MEC)	Description
NF05 x x x 140	ERD-2FCJ x x x	(±5% 1/4W)
RF05 x x x 140		
NF02 x x x 140	ERD-2FCG x x x	(±2% 1/4W)
RF02 x x x 140		

\* Resistance value



Examples

\* Resistance value  
 0.1Ω ..... 001    10Ω ..... 100    1kΩ ..... 102    100kΩ ..... 104  
 0.5Ω ..... 005    18Ω ..... 180    2.7kΩ ..... 272    680kΩ ..... 684  
 1Ω ..... 010    100Ω ..... 101    10kΩ ..... 103    1MΩ ..... 105  
 6.8Ω ..... 068    390Ω ..... 391    22kΩ ..... 223    4.7MΩ ..... 475

### ABBREVIATION AND MARKS

ANT. : ANTENNA	BATT. : BATTERY
CAP. : CAPACITOR	CER. : CERAMIC
CONN. : CONNECTING	DIG. : DIGITAL
HP : HEADPHONE	MIC. : MICROPHONE
μ-PRO : MICROPROCESSOR	REC. : RECORDING
RES. : RESISTOR	SPK : SPEAKER
SW : SWITCH	TRANSF. : TRANSFORMER
TRIM. : TRIMMING	TRS. : TRANSISTOR
VAR. : VARIABLE	X' TAL : CRYSTAL

### NOTE ON SAFETY:

Symbol  Fire or electrical shock hazard. Only original parts should be used to replaced any part marked with symbol  Any other component substitution ( other than original type), may increase risk of fire or electrical shock hazard.

### 安全上の注意 :

 がついている部品は、安全上重要な部品です。必ず指定されている部品番号の部品を使用して下さい。

POS. NO	VERS. COLOR	PART NO. (PCS)	DESCRIPTION	PART NO. (MJI)	POS. NO	VERS. COLOR	PART NO. (PCS)	DESCRIPTION	PART NO. (MJI)
			<b>FRONT (KUP11389) BOARD</b>					<b>RESISTORS</b>	
C601			ELECT 10μF 16V	nsp	R601			220 Ω 1/5W J	nsp
C602			ELECT 10μF 16V	nsp	R602			220 Ω 1/5W J	nsp
C603			CER. 0.022μF 63V J	nsp	R603			1k Ω 1/5W J	nsp
C604			CER. 0.022μF 63V J	nsp	R604			1k Ω 1/5W J	nsp
C605			CER. 100pF 50V K	nsp	R605			1M Ω 1/5W J	nsp
C606			CER. 100pF 50V K	nsp	R606			1M Ω 1/5W J	nsp
C607					R607			56k Ω 1/5W J	nsp
∫			ELECT 10μF 16V	nsp	R608			56k Ω 1/5W J	nsp
C610					R609			22k Ω 1/5W J	nsp
C611			CER. 0.012μF 63V J	nsp	R610			22k Ω 1/5W J	nsp
C612			CER. 0.012μF 63V J	nsp	R611			3.9k Ω 1/5W J	nsp
C613			CER. 0.068μF 63V J	nsp	R612			3.9k Ω 1/5W J	nsp
C614			CER. 0.068μF 63V J	nsp	R613			1.8k Ω 1/5W J	nsp
C615			CER. 4700pF 63V J	nsp	R614			1.8k Ω 1/5W J	nsp
C616			CER. 4700pF 63V J	nsp	R615			820 Ω 1/5W J	nsp
C641					R616			820 Ω 1/5W J	nsp
∫			ELECT 4.7μF 50V	nsp	R641				
C644					∫			56k Ω 1/5W J	nsp
C645			CER. 0.022μF 50V Z	nsp	R644				
C700			CER.0. 1μF 50V Z	nsp	R901			10k Ω 1/5W J	nsp
C901			EECS0HD104V 0.1μF 5.5V	*EX000050R	R902			10k Ω 1/5W J	nsp
C902			ELECT 1μF 50V	nsp	R903			330 Ω 1/5W J	nsp
C903			ELECT 1μF 50V	nsp	R904			330 Ω 1/5W J	nsp
C904			ELECT 100μF 10V	nsp	R905			10k Ω 1/5W J	nsp
C905			ELECT 1μF 50V	nsp	R906			10k Ω 1/5W J	nsp
C906			ELECT 1μF 50V	nsp	R907			47k Ω 1/5W J	nsp
C950					R908			10k Ω 1/5W J	nsp
C951			CER. 0.022μF 50V Z	nsp	R909			47k Ω 1/5W J	nsp
C952			CER. 0.022μF 50V Z	nsp	R910			330 Ω 1/5W J	nsp
C953			CER. 100pF 50V K	nsp	R911			47k Ω 1/5W J	nsp
C954			CER. 100pF 50V K	nsp	R912			100k Ω 1/5W J	nsp
C955			CER. 100pF 50V K	nsp	R913			47k Ω 1/5W J	nsp
C956			CER. 18pF 50V J	nsp	R914			47k Ω 1/5W J	nsp
C957			CER. 18pF 50V J	nsp	R915			820 Ω 1/5W J	nsp
C958					R916			47k Ω 1/5W J	nsp
∫			CER. 0.022μF 50V Z	nsp	R917			4.7k Ω 1/5W J	nsp
C963					R918				
			<b>DIODES</b>		∫			10k Ω 1/5W J	nsp
D901			1N4148	QP13030621	R923				
D902			1N4148	QP13030621	R925			1k Ω 1/5W J	nsp
D903			1N4148	QP13030621	R926			1k Ω 1/5W J	nsp
D904			LED SLR342VCTB7	*HI100930R	R927			1.5k Ω 1/5W J	nsp
D905			LED SLR342VCTB7	*HI100930R	R929			1.5k Ω 1/5W J	nsp
D906			1N4148	QP13030621	R930			1.8k Ω 1/5W J	nsp
D908			LED SLR342VCTB7	*HI100930R	R931			1.8k Ω 1/5W J	nsp
			<b>INTEGRATED CIRCUITS</b>		R932			2.7k Ω 1/5W J	nsp
IC61			NJM2068MD-TE1	*HC104840R	R933			3.3k Ω 1/5W J	nsp
IC91			MICROPROCESSOR	*HU100450R	R934			5.6k Ω 1/5W J	nsp
			<b>TRANSISTORS</b>		R935			2.7k Ω 1/5W J	nsp
Q901			KSA1175Y	*HT100390R	R936			4.7k Ω 1/5W J	nsp
Q902					R937			22k Ω 1/5W J	nsp
∫			KRC107M	*BA001070R	R938			330 Ω 1/5W J	nsp
Q905					R939			4.7k Ω 1/5W J	nsp
Q906			KSB811Y	*HT200340R	R940			22k Ω 1/5W J	nsp
Q907			KRC107M	*BA001070R	R946			10k Ω 1/5W J	nsp
Q908			KRA107M	*BA001060R	R947			10k Ω 1/5W J	nsp
Q909			KRC107M	*BA001070R	R948			10k Ω 1/5W J	nsp
Q910			KRA107M	*BA001060R	R950			22k Ω 1/5W J	nsp
Q911			KSD1021Y	*HT400380R	R951			10k Ω 1/5W J	nsp
Q912			KSD1021Y	*HT400380R	R953			1.2k Ω 1/5W J	nsp
Q913			KRA107M	*BA001060R	R954			10k Ω 1/5W J	nsp
Q914			KRA107M	*BA001060R	R955			2.7k Ω 1/5W J	nsp
Q915			KRA107M	*BA001060R					

POS. NO	VERS. COLOR	PART NO. (PCS)	DESCRIPTION	PART NO. (MJI)	POS. NO	VERS. COLOR	PART NO. (PCS)	DESCRIPTION	PART NO. (MJI)
			<b>MISCELLANEOUS</b>						
BN53			WIRE ASS'Y 2P 350MM	nsp	C055		ELECT 100μF 16V	nsp	
BN61			WIRE ASS'Y 5P 400MM	nsp	C056		CER. 0.047μF 50V Z	nsp	
BN62			WIRE ASS'Y 3P 220MM	nsp	C057		CER. 1000pF 50V K	nsp	
BN71			WIRE ASS'Y 3P 400MM	nsp	C058		MYLAR 1000pF 50V J	nsp	
BN91			FPC CABLE 19P280MM	nsp	C059		ELECT 0.47μF 50V	nsp	
BN92			WIRE ASS'Y 7P 400MM	nsp	C060		ELECT 0.47μF 50V	nsp	
BN93			WIRE ASS'Y 5P 120MM	nsp	C061		ELECT 1.0μF 50V	nsp	
CN41			WAFER 6P 2.0MM	nsp	C062		MYLAR 0.033μF 50V J	nsp	
CN62			WAFER 3P 2.0MM	nsp	C063		MYLAR 0.033μF 50V J	nsp	
CN91			FPC WAFER 19P 1.25MM	nsp	C064		ELECT 10μF 16V	nsp	
CN93			WAFER 5P 2.0MM	nsp	C065		ELECT 10μF 16V	nsp	
FIP1			FIP SVA09MS10	*HQ300350R	C066		ELECT 10μF 16V	nsp	
IC92			IR SENSOR	*HW100510R	C067		ELECT 2.2μF 50V	nsp	
JK71			JACK HEAD PHONE	*YT001820R	C068		ELECT 2.2μF 50V	nsp	
JW81			WIRE ASS'Y 1P 180MM	nsp	C069		ELECT 10μF 35V	nsp	
S900			SW PUSH FOR POWER (MOMS)	*SP000850R	C072		ELECT 100μF 16V	nsp	
S906			SW TACT	*SP000840R	C073		ELECT 100μF 16V	nsp	
S908			SW TACT	*SP000840R	C074		ELECT 470μF 10V	nsp	
S914			SW TACT	*SP000840R	C076		CER. 0.01μF 50V Z	nsp	
S930			ENCODER TUNING UP/DOWN	*SR000150R	C077		CER. 33pF 50V J	nsp	
VR61			VR BASS RK14K128030214C	*RM000360R	C078		CER. 33pF 50V J	nsp	
VR62			VR TREBLE RK14K128030214C	*RM000360R	C079		CER. 0.022μF 50V Z	nsp	
VR63			VR BALANCE RK14K128030214Y	*RM000330R	C080		ELECT 4.7μF 50V	nsp	
VR64			VR MOTOR EUMMG6F25A15	*RY000040R	C081		CER. 0.022μF 50V Z	nsp	
X901			CRYSTAL 8.00MHz	*JX000410R	C082		ELECT 100μF 35V	nsp	
			<b>TUNER (KUP11268) BOARD CAPACITORS</b>		C091		ELECT 100μF 16V	nsp	
CT01			VARIABLE 20pF	*CT000110R	C092		ELECT 100μF 16V	nsp	
C013			CER. 0.01μF 50V Z	nsp	C093		CER. 0.022μF 50V Z	nsp	
C014			CER. 1000pF 50V K	nsp					
C015			CER. 15pF 50V J	nsp					
C016			CER. 0.01μF 50V Z	nsp					
C017			CER. 10pF 50V J	nsp					
C018			CER. 0.047μF 50V Z	nsp					
C019			CER. 0.047μF 50V Z	nsp					
C020			ELECT 1.0μF 50V	nsp					
C021			ELECT 220μF 16V	nsp					
C022			CER. 0.01μF 50V Z	nsp					
C023			CER. 100pF 50V K	nsp					
C024			CER. 100pF 50V K	nsp					
C025			CER. 390pF 50V K	nsp					
C031			CER. 0.047μF 50V Z	nsp					
C033			CER. 15pF 50V J	nsp					
C034			CER. 470pF 50V K	nsp					
C036			CER. 1000pF 50V K	nsp					
C037			ELECT 100μF 16V	nsp					
C038			CER. 0.047μF 50V Z	nsp					
C039			CER. 0.01μF 50V Z	nsp					
C040			CER. 8.2pF 50V K	nsp					
C041			CER. 47pF 50V J	nsp					
C042			ELECT 1.0μF 50V	nsp					
C043			ELECT 4.7μF 16V	nsp					
C045			ELECT 1μF 50V	nsp					
C046			ELECT 1.0μF 50V	nsp					
C047			CER. 6800pF 16V M	nsp					
C048			MYLAR 1500pF 50V J	nsp					
C050			MYLAR 0.022μF 50V J	nsp					
C051			ELECTO. 47μF 50V	nsp					
C054			ELECT 10μF 16V	nsp					
							<b>DIODES</b>		
					D011		VARICAP SVC342-L-AA	*HD400160R	
					D012		1N4148	QP13030621	
					D013		1N4148	QP13030621	
					D014		1N4148	QP13030621	
					D016		ZENER 5.6V 1/2W	*HD301630R	
					D017		1N4148	QP13030621	
							<b>INTEGRATED CIRCUITS</b>		
					IC01		AM/FM IF LA1266	HC10222030	
					IC02		LA3361	*HC104880R	
					IC03		NJM2068MD-TE1	*HC104840R	
					IC04		LC72131M	*HC104820R	
							<b>TRANSISTORS</b>		
					Q011		KTC31920	*HT300480R	
					Q012		KTC31920	*HT300480R	
					Q013		KRA107M	*BA001060R	
					Q014		KRA107M	*BA001060R	
					Q015		DTC143TS	*BA000700R	
					Q016		DTC143TS	*BA000700R	
					Q017		DTA114TS	BA10003210	
							<b>RESISTORS</b>		
					R011		390 Ω 1/5W J	nsp	
					R012		82 Ω 1/5W J	nsp	
					R015		1.8k Ω 1/5W J	nsp	
					R016		820k Ω 1/5W J	nsp	
					R017		560 Ω 1/5W J	nsp	
					R018		470k Ω 1/5W J	nsp	
					R019		270 Ω 1/5W J	nsp	
					R020		1.8k Ω 1/5W J	nsp	
					R021		15k Ω 1/5W J	nsp	
					R022		2.7k Ω 1/5W J	nsp	
					R023		15k Ω 1/5W J	nsp	
					R024		2.2k Ω 1/5W J	nsp	
					R025		100 Ω 1/5W J	nsp	
					R026		1k Ω 1/5W J	nsp	
					R027		100k Ω 1/5W J	nsp	

POS. NO	VERS. COLOR	PART NO. (PCS)	DESCRIPTION	PART NO. (MJI)	POS. NO	VERS. COLOR	PART NO. (PCS)	DESCRIPTION	PART NO. (MJI)	
R028			470 Ω 1/4W J	nsp				<b>MAIN (KUP11388) BOARD CAPACITORS</b>		
R029			150 Ω 1/5W J	nsp						
R030			100k Ω 1/5W J	nsp	C201		CER. 18pF 50V J		nsp	
R031			22k Ω 1/5W J	nsp	C202		CER. 18pF 50V J		nsp	
R032			82 Ω 1/5W J	nsp	C203		CER. 100pF 50V K		nsp	
R033			22k Ω 1/5W J	nsp	C204		CER. 100pF 50V K		nsp	
R034			100k Ω 1/5W J	nsp	C205		CER. 0.1μF 50V Z		nsp	
R035			10k Ω 1/4W J	nsp	C206		CER. 0.1μF 50V Z		nsp	
R036			22k Ω 1/5W J	nsp	C207		CER. 1000pF 50V K		nsp	
R037			470 Ω 1/5W J	nsp	C208		CER. 1000pF 50V K		nsp	
R038			5.6k Ω 1/5W J	nsp	C209		ELECT 47μF 25V		nsp	
R039			1k Ω 1/5W J	nsp	C210		ELECT 47μF 25V		nsp	
R040			100k Ω 1/5W J	nsp	C211		CER. 5600pF 50V J		nsp	
R041			470 Ω 1/5W J	nsp	C212		CER. 5600pF 50V J		nsp	
R051			3.3k Ω 1/5W J	nsp	C213		CER. 0.022μF 50V J		nsp	
R056							C214			CER. 0.022μF 50V J
R057			1k Ω 1/5W J	nsp	C215		ELECT 4.7μF 50V		nsp	
R060							C216			ELECT 4.7μF 50V
R061			330 Ω 1/5W J	nsp	C217		ELECT 47μF 25V		nsp	
R062			330 Ω 1/5W J	nsp	C218		ELECT 47μF 25V		nsp	
R063			100k Ω 1/5W J	nsp	C239		CER. 0.1μF 50V Z		nsp	
R064			100k Ω 1/5W J	nsp	C240		CER. 0.1μF 50V Z		nsp	
R065			10k Ω 1/5W J	nsp	C241		CER. 0.1μF 50V Z		nsp	
R066			10k Ω 1/5W J	nsp	C243		ELECT 47μF 25V		nsp	
R067			10k Ω 1/5W J	nsp	C244		ELECT 47μF 25V		nsp	
R069			270 Ω 1/4W J	nsp	C245		ELECT 47μF 25V		nsp	
R069			18k Ω 1/5W J	nsp	C251		ELECT 1.0μF 50V		nsp	
R070			18k Ω 1/5W J	nsp	}		ELECT 4.7μF 50V		nsp	
R071			100k Ω 1/5W J	nsp	C254					
R072			100k Ω 1/5W J	nsp	C255		CER. 0.022μF 50V Z		nsp	
R080			1k Ω 1/5W J	nsp	C256		CER. 0.022μF 50V Z		nsp	
R084							C267			CER. 0.1μF 50V Z
R085			10k Ω 1/5W J	nsp	C268		CER. 0.1μF 50V Z		nsp	
R086			560 Ω 1/5W J	nsp	C291		CER. 0.022μF 50V Z		nsp	
R087			5.6k Ω 1/5W J	nsp	C292		ELECT 220μF 16V		nsp	
R088			10k Ω 1/5W J	nsp	C301		ELECT 4.7μF 50V		nsp	
R093			3.3k Ω 1/5W J	nsp	C302		ELECT 4.7μF 50V		nsp	
R095			390 Ω 1/4W J	nsp	C303		CER. 100pF 50V K		nsp	
R096			22k Ω 1/5W J	nsp	C304		CER. 100pF 50V K		nsp	
R097			1 Ω 1/5W J	nsp	C305		ELECT 47μF 16V		nsp	
VR01			SEMI FIXED EVNDJAA03B24	*RA000790R	C306		ELECT 47μF 16V		nsp	
VR02			SEMI FIXED EVNDJAA03B24	*RA000790R	C307		CER. 1pF 50V C		nsp	
VR03			SEMI FIXED EVNDJAA03B14	*RA000880R	C308		CER. 1pF 50V C		nsp	
VR04			SEMI FIXED EVNDJAA03B13	*RA000870R	C309		CER. 180pF 50V K		nsp	
			<b>MISCELLANEOUS</b>		C310		CER. 180pF 50V K		nsp	
CF01				CERAMIC FILTER	*FF100230R	C313			CER. 0.022μF 50V J	nsp
CF02				SFE10.7MS8H-A-T		C314			CER. 0.022μF 50V J	nsp
				CERAMIC FILTER	*FF100230R	C317			CER. 0.022μF 50V J	nsp
				SFE10.7MS8H-A-T		C318			CER. 0.022μF 50V J	nsp
CF03				CERAMIC FILTER SFZ450F	FF10045290	C319			ELECT 10μF 50V	nsp
CN11				WAFER BOARD 11P 2.0MM	nsp	C320			ELECT 10μF 50V	nsp
FP11				FM FRONT-END PACK	*AV000070R	C381			ELECT 4.7μF 50V	nsp
				FTA3-508HB		C382			ELECT 470μF 10V	nsp
L012				COIL AM ANT 2	*LA000090R	C391			CER. 0.047μF 50V J	nsp
L013			COIL AM OSC	*LO000060R	C392		CER. 0.047μF 50V J		nsp	
L017			COIL MPX	*LS000060R	C397		CER. 0.022μF 50V Z		nsp	
L018			COIL MPX	*LS000060R	C401					
					}		CER. 0.047μF 50V J		nsp	
T011			I.F.T FM	*LA000110R	C404					
T012			I.F.T FM	*LI000070R	C411		CER. 0.047μF 50V Z		nsp	
T013			I.F.T AM	*LA000100R	C412		CER. 0.047μF 50V Z		nsp	
					C413		CER. 0.047μF 50V Z	nsp		
X011			CERAMIC FILTER BFU450C4N	*FF100190R	C416		CER. 0.022μF 50V Z	nsp		
X012			CRYSTAL 7.2MHz	JX07001261	C417		CER. 0.022μF 50V Z	nsp		
					C418		ELECT 100μF 35V	nsp		
					C419		ELECT 100μF 35V	nsp		
					C420		ELECT 100μF 25V	nsp		

POS. NO	VERS. COLOR	PART NO. (PCS)	DESCRIPTION	PART NO. (MJI)	POS. NO	VERS. COLOR	PART NO. (PCS)	DESCRIPTION	PART NO. (MJI)
C421			ELECT 100μF 25V	nsp	Q326		2SC4467		HT344673A0
C424			ELECT 100μF 16V	nsp	Q327		2SA1694		HT116942B0
C425			ELECT 100μF 16V	nsp	Q328		2SA1694		HT116942B0
C501			ELECT 4.7μF 50V	nsp	Q329		KSC2785Y		*HT300590R
C502			ELECT 47μF 50V	nsp	Q330		KSC2785Y		*HT300590R
C503			ELECT 47μF 25V	nsp	Q381		KSA1175Y		*HT100390R
C505			CER. 0.022μF 50V Z	nsp	Q382		KRA107M		*BA001060R
C506			CER. 0.022μF 50V Z	nsp	Q383		KSC2785Y		*HT300590R
C311			ELECT 220μF 63V	nsp	Q384		KSC2785Y		*HT300590R
C312			ELECT 220μF 63V	nsp	Q394		KRC107M		*BA001070R
C315			ELECT 220μF 63V	nsp	Q396		KRC107M		*BA001070R
C316			ELECT 220μF 63V	nsp	Q411		KTC2026Y		*HT300780R
C405			ELECT 6800μF 63V	*EA001020R	Q412		KTA1046Y		*HT100530R
C406			ELECT 6800μF 63V	*EA001020R	Q413		KSC2316Y		*HT300580R
C414			ELECT 2200μF 35V	*EA000850R	Q414		KSB811Y		*HT200340R
C415			ELECT 1000μF 35V	EA10803510	Q415		KSB811Y		*HT200340R
C504			ELECT 2200μF 16V	OA22801626	Q501		KRC107M		*BA001070R
<b>DIODES</b>					<b>RESISTORS</b>				
D201			1N4148	QP13030621	R203		390 Ω 1/5W J		nsp
D241			1N4148	QP13030621	R204		390 Ω 1/5W J		nsp
D301					R205		47k Ω 1/5W J		nsp
∫			1N4148	QP13030621	R206		47k Ω 1/5W J		nsp
D306					R207		200 Ω 1/5W J		nsp
D381			1N4148	QP13030621	R208		200 Ω 1/5W J		nsp
D391			1N4148	QP13030621	R209		12k Ω 1/5W J		nsp
D392			1N4148	QP13030621	R210		12k Ω 1/5W J		nsp
D401			DIODE BRIDGE 8A 400V	*HE200190R	R211		180k Ω 1/5W J		nsp
D402					R212		180k Ω 1/5W J		nsp
∫			1N4003	HD200010AR	R213		560 Ω 1/5W J		nsp
D405					R214		560 Ω 1/5W J		nsp
D406			ZENER 16V 1/2W	*HD301930R	R215		100k Ω 1/5W J		nsp
D407			ZENER 16V 1/2W	*HD301930R	R216		100k Ω 1/5W J		nsp
D408			ZENER 5.6V 1/2W	HD30561000	R217		220 Ω 1/5W J		nsp
D501				HD30621000	R218		220 Ω 1/5W J		nsp
D502			ZENER 12V 1/2W	*HD301730R	R221		1k Ω 1/5W J		nsp
D503			ZENER 15V 1/2W	*HD301590R	R222		1k Ω 1/5W J		nsp
D504			1N4003	HD200010AR	R225		1k Ω 1/5W J		nsp
D505			1N4148	QP13030621	R226		1k Ω 1/5W J		nsp
D506			1N4148	QP13030621	R231				
D507			1N4148	QP13030621	∫		1k Ω 1/5W J		nsp
D508			1N4003	HD200010AR	R234				
<b>INTEGRATED CIRCUITS</b>					R243		220 Ω 1/5W J		nsp
IC21			NJM2068MD-TE1	*HC104840R	R244		220 Ω 1/4W J		nsp
IC22			LC78211	HC10308030	R245		1k Ω 1/5W J		nsp
IC23			NJM2068MD-TE1	*HC104840R	R246		1k Ω 1/5W J		nsp
IC51			MC7806	*HC300240R	R247		1k Ω 1/5W J		nsp
<b>TRANSISTORS</b>					R248		100k Ω 1/5W J		nsp
Q201			KTD1302T	*HT400400R	R251				
Q202			KTD1302T	*HT400400R	∫		47k Ω 1/5W J		nsp
Q303					R254				
∫			KTA1268GR	*HT100400R	R255		220 Ω 1/5W J		nsp
Q310					R256		220 Ω 1/5W J		nsp
Q311					R265		1k Ω 1/5W J		nsp
∫			KTC3200GR	*HT300610R	R266		1k Ω 1/5W J		nsp
Q314					R267		3.3k Ω 1/5W J		nsp
Q315			KSA910Y	*HT100450R	R268		3.3k Ω 1/5W J		nsp
Q316			KSA910Y	*HT100450R	R269		12 Ω 1/5W J		nsp
Q317			2SC4137V	*HT300660R	R301		1k Ω 1/5W J		nsp
Q318			2SC4137V	*HT300660R	R302		1k Ω 1/5W J		nsp
Q319			KSC2310Y	*HT300670R	R303		33k Ω 1/5W J		nsp
Q320			KSC2310Y	*HT300670R	R304		33k Ω 1/5W J		nsp
Q321			2SD1763AE	*HT400390R	R305		47k Ω 1/5W J		nsp
Q322			2SD1763AE	*HT400390R	R306		47k Ω 1/5W J		nsp
Q323			2SB1186AE	*HT200350R	R307		270 Ω 1/5W J		nsp
Q324			2SB1186AE	*HT200350R	R308		270 Ω 1/5W J		nsp
Q325			2SC4467	HT344673A0	R309		10k Ω 1/5W J		nsp
					R310		10k Ω 1/5W J		nsp

POS. NO	VERS. COLOR	PART NO. (PCS)	DESCRIPTION	PART NO. (MJI)	POS. NO	VERS. COLOR	PART NO. (PCS)	DESCRIPTION	PART NO. (MJI)
R311			180 Ω 1/5W J	nsp	R411			0.47 Ω 1W J FUSABLE	*NH000080R
R312			180 Ω 1/5W J	nsp	R412			0.47 Ω 1W J - FUSABLE	*NH000080R
R313			1.5k Ω 1/5W J	nsp	R413			15k Ω 1/5W J	nsp
R314			1.5k Ω 1/5W J	nsp	R414			15k Ω 1/5W J	nsp
R315			180 Ω 1/5W J	nsp	R415			2.2k Ω 1/5W J	nsp
R316			180 Ω 1/5W J	nsp	R416			2.2k Ω 1/5W J	nsp
R317			1.5k Ω 1/5W J	nsp	R417			2.2k Ω 1/5W J	nsp
R318			1.5k Ω 1/5W J	nsp	R418			4.7k Ω 1/5W J	nsp
R319			33k Ω 1/5W J	nsp	R419			4.7k Ω 1/5W J	nsp
R320			33k Ω 1/4W J	nsp	R501			3.3M Ω 1/2W	nsp
R321			1.8k Ω 1/5W J	nsp	R502			56 Ω 1/4W J	nsp
R322			1.8k Ω 1/5W J	nsp	R503			56 Ω 1/4W J	nsp
R323			560 Ω 1/5W J	nsp	R504			180 Ω 1/4W J	nsp
R324			560 Ω 1/5W J	nsp	R505			82 Ω 1/4W J	nsp
R325					R507			10 Ω 1/4W J	nsp
}			560 Ω 1/5W J	nsp					
R330								<b>MISCELLANEOUS</b>	
R331					BN11			WAFER BOARD 11P 2.0MM	nsp
}			4.7k Ω 1/5W J	nsp	BN41			WIRE ASS'Y 6P 220MM	nsp
R333									
R334			4.7k Ω 1/5W J	nsp	CN51			WAFER 2P 7.92MM	nsp
R335			560 Ω 1/5W J	nsp	CN52			WAFER 2P 7.92MM	nsp
R336			560 Ω 1/5W J	nsp	CN53			WAFER 2P 10MM	nsp
R337					CN56			WAFER 6P 2.5MM	nsp
}			22k Ω 1/5W J	nsp	CN57			WAFER 3P 3.96MM	nsp
R340					CN61			WAFER 5P 2.0MM	nsp
R341			1.2k Ω 1/5W J	nsp	CN71			WAFER 3P 2.0MM	nsp
R342			1.2k Ω 1/5W J	nsp	CN91			FPC WAFER 19P 1.25MM	nsp
R343			470 Ω 1/5W J	nsp	CN92			WAFER 7P 2.0MM	nsp
R344			470 Ω 1/5W J	nsp					
R345			10k Ω 1/5W J	nsp	F501			FUSE 5A 250V (UL)	*FS000660R
R346			10k Ω 1/5W J	nsp	JK21			JACK IN/OUT	*YT002240R
R347					JK22			JACK IN/OUT	*YT002240R
}			120 Ω 1/5W J	nsp	JK23			JACK REMOTE CONTROL IN/OUT	*KJ4N039Z
R350									
R351					JK30			SPEAKER TERMINAL 8P	*YT001480R
}			27 Ω 1/5W J	nsp	L301			COIL 0.5UH K	*LC107210R
R354					L302			COIL 0.5UH K	*LC107210R
R355			220 Ω 1/4W J	nsp					
R356			220 Ω 1/4W J	nsp	OL11			OUTLET UL (2P)	*YT001620R
R357			0.22 Ω 5W J x 2 - CEMENT	*GO000006R	RY51			RELAY POWER SDT-S-112DMR	*LY000230R
R358			0.22 Ω 5W J x 2 - CEMENT	*GO000006R					
R359			1k Ω 1/5W J	nsp	RY91			RELAY OSA-SS-212DM5	*LY000210R
R360			1k Ω 1/5W J	nsp	RY92			RELAY OSA-SS-212DM5	*LY000210R
R361			1.8k Ω 1/5W J	nsp					
R362			1.8k Ω 1/5W J	nsp	S101			SW TACT	*KST1A010Z
R363			1k Ω 1/5W J	nsp	S903			SW TACT	*SP000840R
R364			1k Ω 1/5W J	nsp	S904			SW TACT	*SP000840R
R365			10k Ω 1/5W J	nsp	S905			SW TACT	*SP000840R
R366			10k Ω 1/5W J	nsp					
R367					TH30			POSISTOR PTH9M04BC471TS	*HP000070R
}			10 Ω 1/4W J	nsp	T501			SUB-TRANSFORMER	*TS000990R
R370					T502			MAIN TRANSFORMER	*TS001230R
R371			390 Ω 1W J	GA05391010					
R372			390 Ω 1W J	GA05391010					
R373			27k Ω 1/5W J	nsp					
R374			27k Ω 1/5W J	nsp					
R381			47k Ω 1/5W J	nsp					
R382			1k Ω 1/5W J	nsp					
R383			1.5k Ω 1/5W J	nsp					
R384			1.5k Ω 1/5W J	nsp					
R391			10 Ω 1W J	GA05100010					
R392			10 Ω 1W J	GA05100010					
R393			10 Ω 1W J	GA05100010					
R394			10 Ω 1/5W J	nsp					
R395			10 Ω 1/5W J	nsp					
R401									
}			39k Ω 1/4W J	nsp					
R404									