

Service Manual

SR-68U
SR-48mk2U
74SR39/02B

Hi-Fi stereo receiver

SR-68

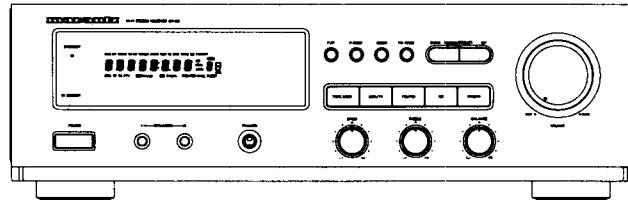

SR-48mk2

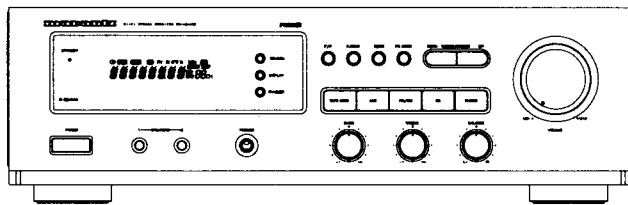

SR-39

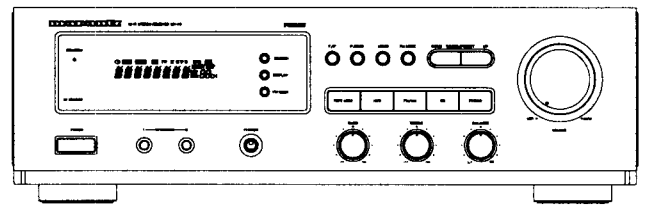

TABLE OF CONTENTS

SECTION	PAGE
1. TECHNICAL SPECIFICATIONS	1
2. WIRING DIAGRAM	2
3. BLOCK DIAGRAM	3
4. SCHEMATIC DIAGRAM AND PARTS LOCATIONS	5
5. MICROPROCESSOR DESCRIPTIONS	23
6. ADJUSTMENTS PROCEDURE	24
7. EXPLODED VIEW AND PARTS LIST (SR-68/SR-48mk2)	27
8. EXPLODED VIEW AND PARTS LIST (SR-39)	29
9. ELECTRICAL PARTS LIST	31

Please use this service manual with referring to the user guide (D.F.U) without fail.

marantz®

model SR-68/SR-48mk2/SR-39

MARANTZ DESIGN AND SERVICE

Using superior design and selected high grade components, **MARANTZ** company has created the ultimate in stereo sound. Only original **MARANTZ** parts can insure that your **MARANTZ** product will continue to perform to the specifications for which it is famous.

Parts for your **MARANTZ** equipment are generally available to our National Marantz Subsidiary or Agent.

ORDERING PARTS :

Parts can be ordered either by mail or by Fax.. In both cases, the correct part number has to be specified.

The following information must be supplied to eliminate delays in processing your order :

1. Complete address
2. Complete part numbers and quantities required
3. Description of parts
4. Model number for which part is required
5. Way of shipment
6. Signature : any order form or Fax. must be signed, otherwise such part order will be considered as null and void.

USA

MARANTZ AMERICA, INC.
440 MEDINAH ROAD
ROSELLE, ILLINOIS 60172
USA
PHONE : 630 - 307 - 3100
FAX : 630 - 307 - 2687

CANADA

LENBROOK INDUSTRIES LIMITED
633 GRANITE COURT,
PICKERING, ONTARIO L1W 3K1
CANADA
PHONE : 905 - 831 - 6333
FAX : 905 - 831 - 6936

EUROPE / TRADING

MARANTZ EUROPE B. V.
P.O. BOX 80002
BUILDING SFF2
5600 JB EINDHOVEN
THE NETHERLANDS
PHONE : +31 - 40 - 2732241
FAX : +31 - 40 - 2735578

PROFESSIONAL USA

SUPERSCOPE TECHNOLOGIES, INC.
MARANTZ PROFESSIONAL PRODUCTS
2640 WHITE OAK CIRCLE, SUITE A
AURORA, ILLINOIS 60504 USA
PHONE : 630 - 820 - 4800
FAX : 630 - 820 - 8103

PROFESSIONAL CANADA

TC ELECTRONICS CANADA LTD.
540 FIRING AVE.
BAIE D'URF..., QUEBEC H9X 3T2
CANADA
PHONE : 514 - 457 - 4044
FAX : 514 - 457 - 5524

KOREA

MK ENTERPRISES LTD.
2F SHINHAN BLDG., 247-17 SEOKYO-DONG
MAPO-KU, SEOUL
KOREA
PHONE : +82 - 2 - 323 - 2155
FAX : +82 - 2 - 323 - 2154

BRAZIL

MARANTZ BRAZIL
CAIXA POSTAL 21462
CEP 04698-970
SAO PAULO, SP, BRAZIL
PHONE : 0800 - 123123 (Discagem Direta Gratuita)
FAX : +55 11 534. 8988

THAILAND

MRZ STANDARD CO., LTD.
746 - 754 MAHACHAI RD.,
WANGBURAPAPIROM, PHRANAKORN,
BANGKOK, 10200 THAILAND
PHONE : +66 - 2 - 222 - 9181
FAX : +66 - 2 - 224 - 6795

AUSTRALIA / NEW ZEALAND

SCAN AUDIO PTY. LTD.
52 CROWN STREET, RICHMOND 3121
VICTORIA
AUSTRALIA
PHONE : +61 - 3 - 9429 - 2199
FAX : +61 - 3 - 9429 - 9309

TAIWAN

PAI-YUNG CO., LTD.
6 TH FL NO, 148 SUNG KIANG ROAD,
TAIPEI, 10429, TAIWAN R.O.C.
PHONE : +886 (2) 5221304
FAX : +886 (2) 5630415

MALAYSIA

WO KEE HONG ELECTRONICS SDN. BHD.
NO. 102 JALAN SS 21/35, DAMANSARA
UTAMA, 47400 PETALING JAYA
SELANGOR DARUL EHSAN,
MALAYSIA
PHONE : +60 3 - 7184666
FAX : +60 3 - 7173828

JAPAN Technical

MARANTZ JAPAN, INC.
35-1, 7- CHOME, SAGAMIONO
SAGAMIHARA - SHI, KANAGAWA
JAPAN 228-8505
PHONE : +81 42 748 1013
FAX : +81 42 741 9190

日本マランツ株式会社

本社 〒228-8505
神奈川県相模原市相模大野7-35-1
営業本部 〒150-0022
東京都渋谷区恵比寿南1-11-9

SINGAPORE

FORWARD MARKETING (S) PTE. LTD.
23, LORONG 8, TOA PAYOH,
SINGAPORE 319257.
PHONE : +65 2583640
FAX : +65 3564047

SHOCK, FIRE HAZARD SERVICE TEST :

CAUTION : After servicing this appliance and prior to returning to customer, measure the resistance between either primary AC cord connector pins (with unit NOT connected to AC mains and its Power switch ON), and the face or Front Panel of product and controls and chassis bottom.

Any resistance measurement less than 1 Megohms should cause unit to be repaired or corrected before AC power is applied, and verified before it is return to the user/customer.

Ref. UL Standard No. 1492.

In case of difficulties, do not hesitate to contact the Technical Department at above mentioned address.

1. TECHNICAL SPECIFICATIONS

FM Tuner section

Frequency Range	87.5 - 108.0 MHz
Usable Sensitivity	IHF 2.0 μ V/ 11.3 dBf
Signal to Noise Ratio	Mono/Stereo 70/65 dB
Distortion	Mono/Stereo 0.3/0.5 %
Stereo separation	1 kHz 32 dB
A.C.S	\pm 400 kHz 50 dB
Image Rejection	98.1 MHz 40 dB
Tuner Output Level	1 kHz, \pm 75 kHz Dev 600mV

AM Tuner Section

Frequency Range	
SR-68, SR-48mk2 version	520-1710 kHz
SR-39 version	522-1620 kHz
Usable Sensitivity	Loop 500 μ V
Signal to Noise Ratio	40 dB
Distortion	1 kHz, 30 % Mod. 1.0 %
Selectivity	\pm 10 kHz 25 dB

Audio Section

Rated Power	
SR-68 version	20 Hz - 20 kHz 8 ohms 75 W/Ch
SR-48mk2 version	20 Hz - 20 kHz 8 ohms 50 W/Ch
SR-39 version	20 Hz - 20 kHz 8 ohms 30 W/Ch
T.H.D	20 Hz - 20 kHz 8 ohms 0.09 %
Input Sensitivity / Impedance	
Linear	200 mV/47 kohms
Signal to Noise Ratio (IHF-A)	
Linear	95dB

Others

Power Supply	
SR-68, SR-48mk2 version	AC 120V 60 Hz
SR-39 version	AC 230V 50 Hz
Power Consumption	
SR-68 version	2.0 A
SR-48mk2 version	1.1 A
SR-39 version	70 Watt

Dimensions (MAX)

Width	442 mm
Height	136 mm
Depth	
SR-68, SR-48mk2 version	375 mm
SR-39 version	362 mm
Weight	
SR-68 version	8.2 kg
SR-48mk2 version	7.7 kg
SR-39 version	6.9 kg

Specifications subject to change without prior notice

2. WIRING DIAGRAM

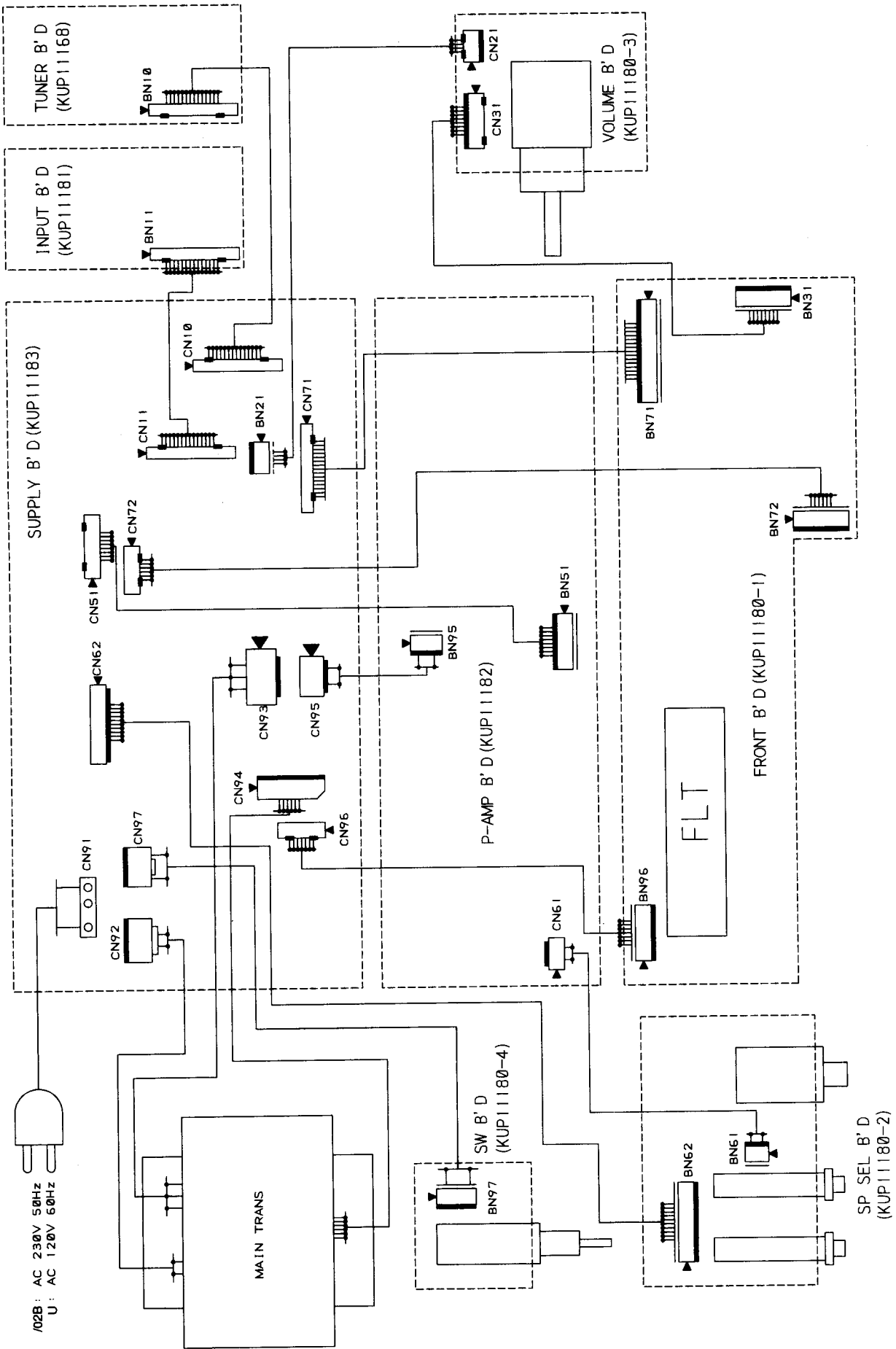

3. BLOCK DIAGRAM

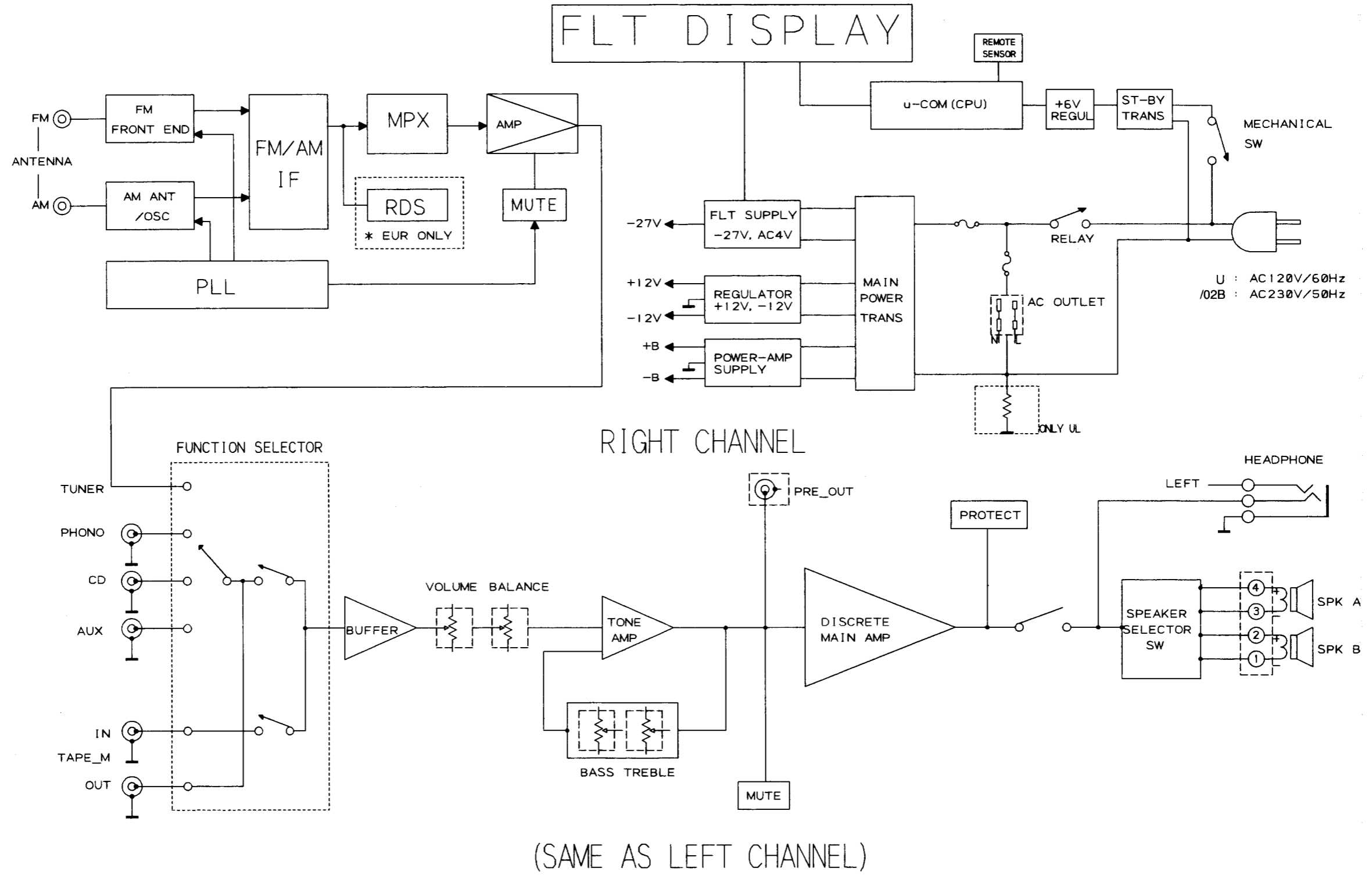

4. SCHEMATIC DIAGRAM AND PARTS LOCATIONS

TUNER SCHEMATIC DIAGRAM (U VERSION)

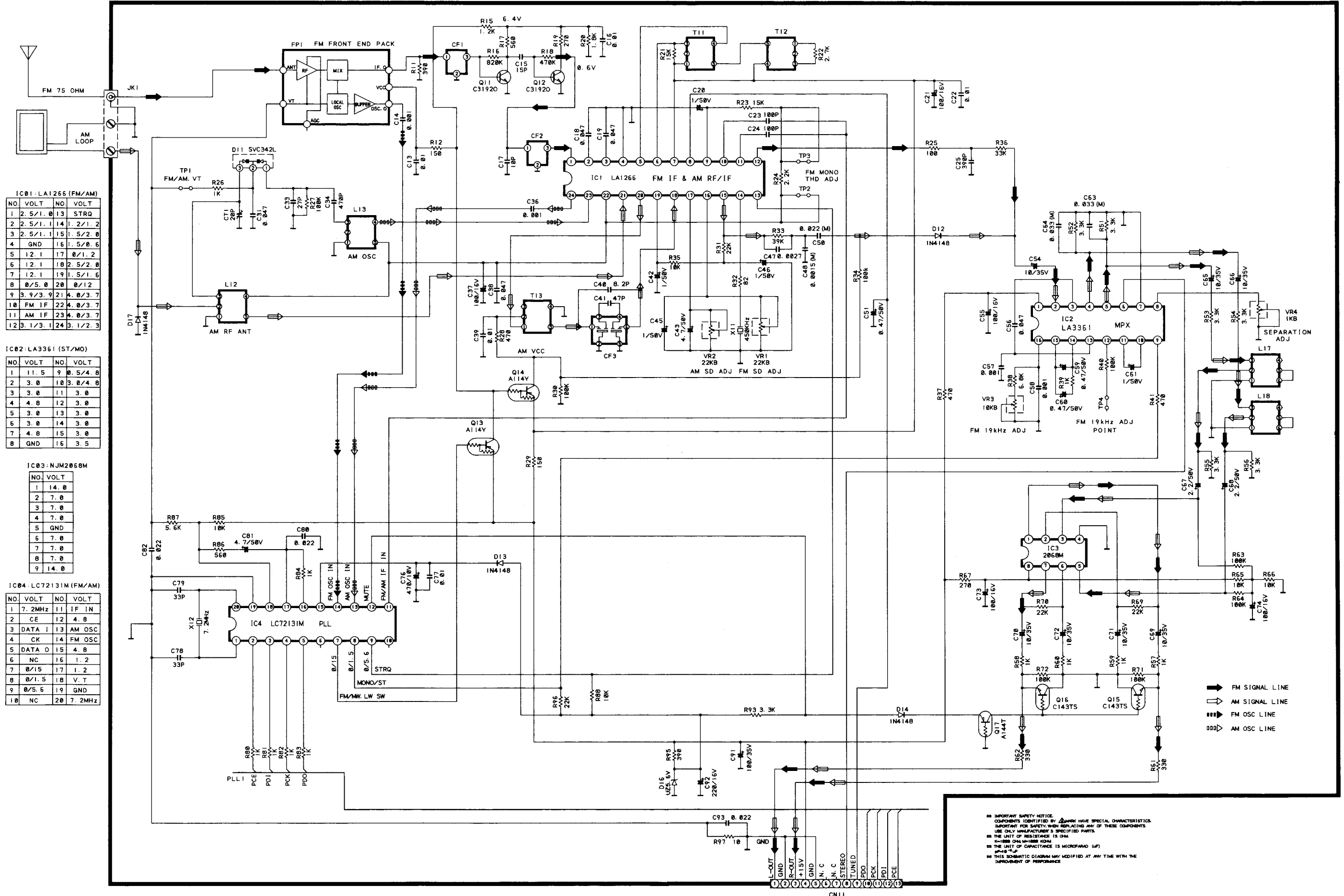

IC01: LA1266 (FM/AM)

NO.	VOLT	NO.	VOLT
1	2.5/1.0	13	STRQ
2	2.5/1.1	14	1.2/1.2
3	2.5/1.1	15	1.5/2.0
4	GND	16	1.5/0.6
5	12.1	17	0/1.2
6	12.1	18	2.5/2.0
7	12.1	19	1.5/1.6
8	0/5.0	20	0/1.2
9	3.9/3.9	21	4.0/3.7
10	FM IF	22	4.0/3.7
11	AM IF	23	4.0/3.7
12	3.1/3.1	24	3.1/2.3

IC02: LA3361 (ST/MO)

NO.	VOLT	NO.	VOLT
1	11.5	9	0.5/4.0
2	3.0	10	3.0/4.0
3	3.0	11	3.0
4	4.8	12	3.0
5	3.0	13	3.0
6	3.0	14	3.0
7	4.8	15	3.0
8	GND	16	3.5

IC03: NJM2068M

NO.	VOLT
1	14.0
2	7.0
3	7.0
4	7.0
5	GND
6	7.0
7	7.0
8	7.0
9	14.0

IC04: LC72131M (FM/AM)

NO.	VOLT	NO.	VOLT
1	7.2MHz	11	IF IN
2	CE	12	4.8
3	DATA 1	13	AM OSC
4	CK	14	FM OSC
5	DATA 0	15	4.8
6	NC	16	1.2
7	0/1.5	17	1.2
8	0/1.5	18	V.T
9	0/5.5	19	GND
10	NC	20	7.2MHz

IMPORTANT SAFETY NOTICE: COMPONENTS IDENTIFIED BY MARK HAVE SPECIAL CHARACTERISTICS. IMPORTANT FOR SAFETY, WHEN REPLACING ANY OF THESE COMPONENTS USE ONLY MANUFACTURER'S SPECIFIED PARTS. THE UNIT OF RESISTANCE IS OHM. THE UNIT OF CAPACITANCE IS MICROFARAD (μF). THIS SCHEMATIC DIAGRAM MAY BE MODIFIED AT ANY TIME WITH THE IMPROVEMENT OF PERFORMANCE.

TUNER BOARD (U VERSION)

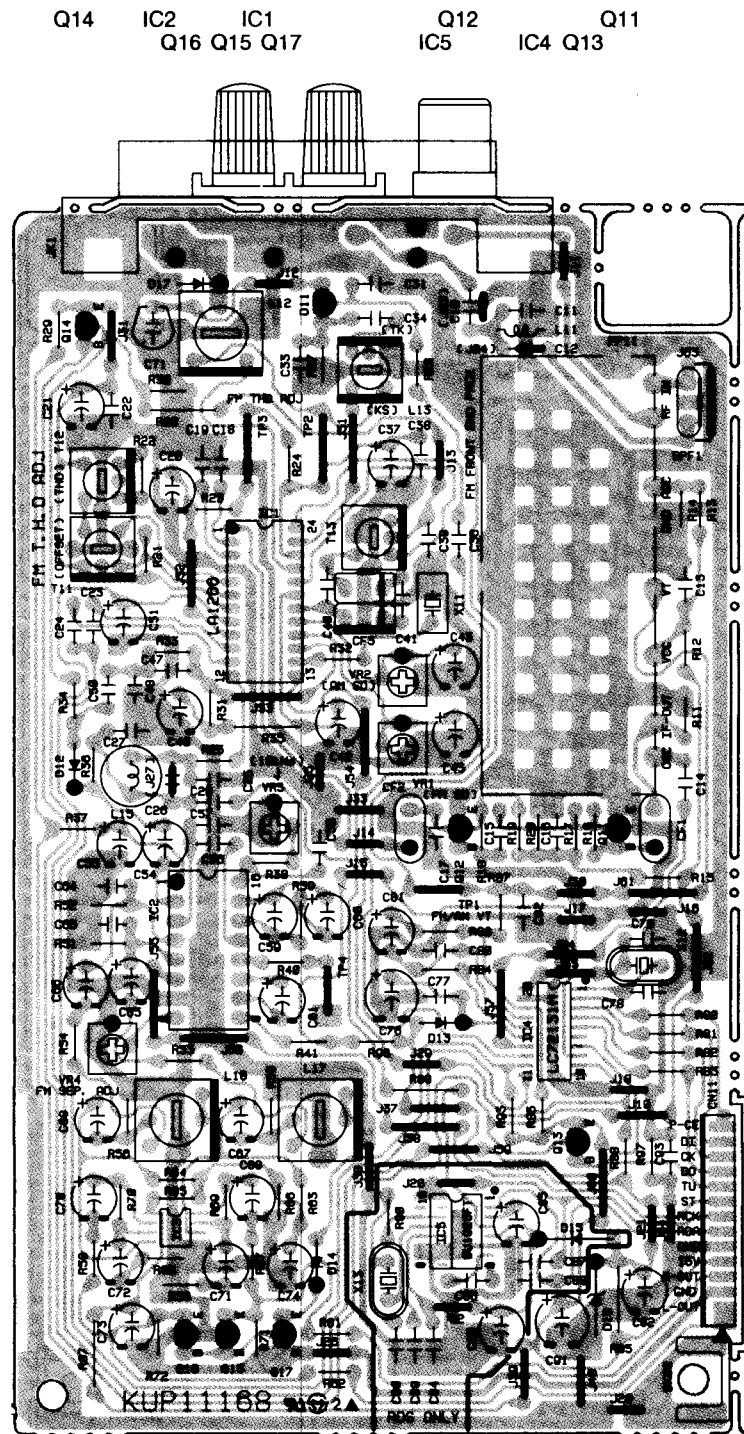

TUNER BOARD (/02B VERSION)

Q14 IC2 IC1 Q12 Q11
Q16 Q15 Q17 IC5 IC4 Q13

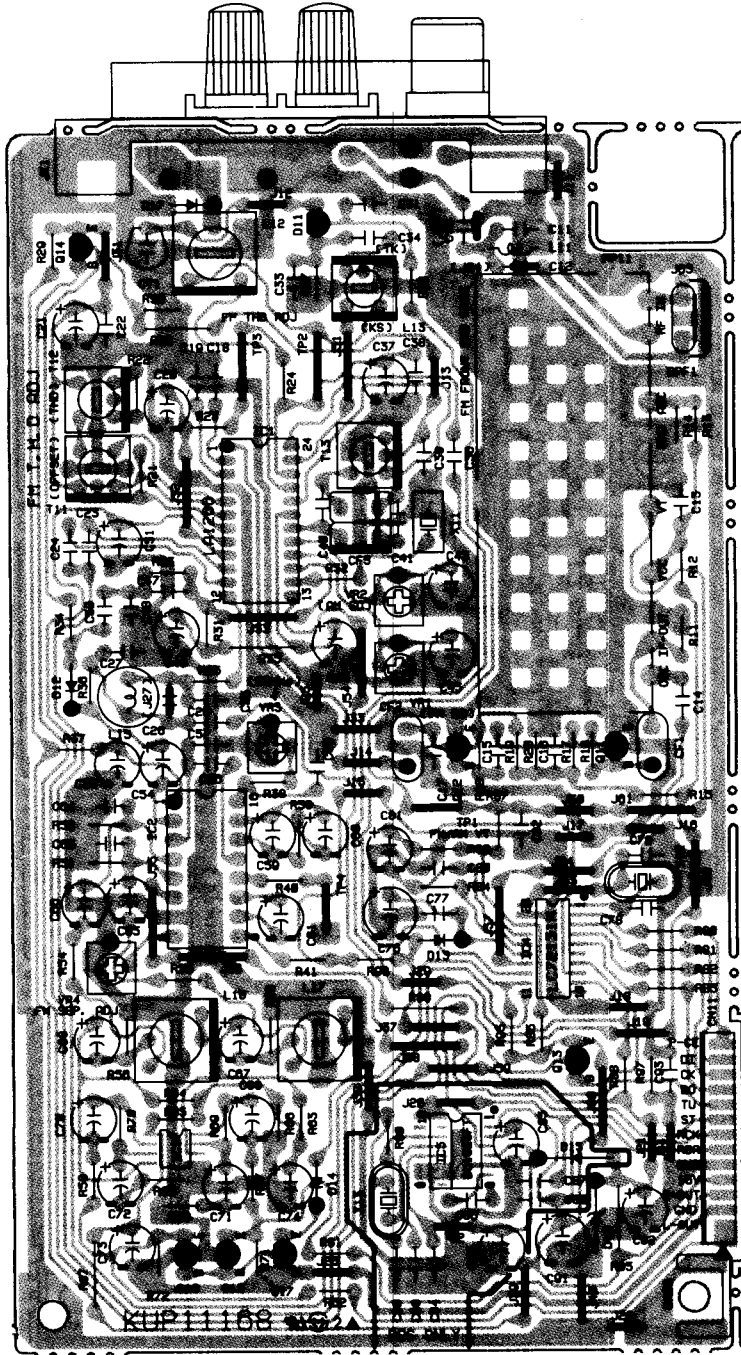

TUNER SCHEMATIC DIAGRAM (02B VERSION)

IC01: LA1266 (FM/AM)

NO.	VOLT	NO.	VOLT
1	2.5/1.0	13	STRQ
2	2.5/1.1	14	1.2/1.2
3	2.5/1.1	15	1.5/2.0
4	GND	16	1.5/0.6
5	12.1	17	0/1.2
6	12.1	18	2.5/2.0
7	12.1	19	1.5/1.6
8	0/5.0	20	0/12
9	3.9/3.9	21	4.0/3.7
10	FM IF	22	0/3.7
11	AM IF	23	0/3.7
12	3.1/3.1	24	3.1/2.3

IC02: LA3361 (ST/MO)

NO.	VOLT	NO.	VOLT
1	11.5	9	0.5/4.8
2	3.0	10	3.0/4.8
3	3.0	11	3.0
4	4.8	12	3.0
5	3.0	13	3.0
6	3.0	14	3.0
7	4.8	15	3.0
8	GND	16	3.5

IC03: NJM2068M

NO.	VOLT
1	14.0
2	7.0
3	7.0
4	7.0
5	GND
6	7.0
7	7.0
8	7.0
9	14.0

IC04: LC72131M (FM/AM)

NO.	VOLT	NO.	VOLT
1	7.2MHz	11	IF IN
2	CE	12	0/6.8
3	DATA 1	13	AM OSC
4	CK	14	FM OSC
5	DATA 0	15	4.8
6	NC	16	1.2
7	0/15	17	1.2
8	0/1.5	18	V.T
9	0/5.5	19	GND
10	NC	20	7.2MHz

IC05: BFU1923F (RDS)

NO.	VOLT	NO.	VOLT
1	OPEN	9	OPEN
2	DATA	10	GND
3	OPEN	11	GND
4	MPX_IN	12	5.0V
5	5.0V	13	OSC
6	GND	14	OSC
7	3.0	15	OPEN
8	1.2	16	CLOCK

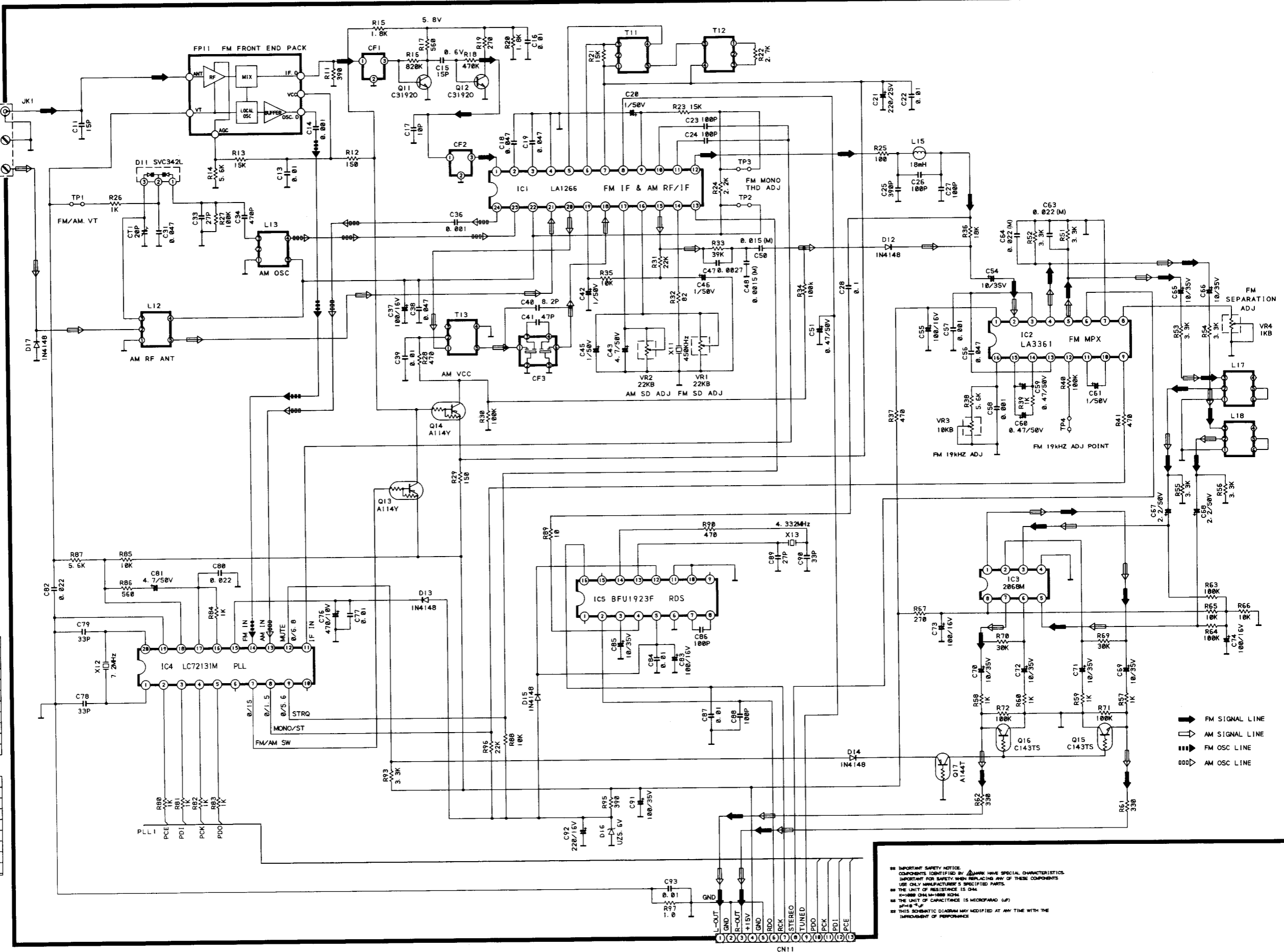

IMPORTANT SAFETY NOTICE:
 COMPONENTS IDENTIFIED BY MARK HAVE SPECIAL CHARACTERISTICS
 IMPORTANT FOR SAFETY. WHEN REPLACING ANY OF THESE COMPONENTS
 USE ONLY MANUFACTURER'S SPECIFIED PARTS.
 THE UNIT OF RESISTANCE IS OHM.
 K=1000 OHM=1000 OHM
 M=1000 OHM=1000 OHM
 THE UNIT OF CAPACITANCE IS MICROFARAD (UF)
 THIS SCHEMATIC DIAGRAM MAY BE MODIFIED AT ANY TIME WITH THE
 IMPROVEMENT OF PERFORMANCE

INPUT SCHEMATIC DIAGRAM

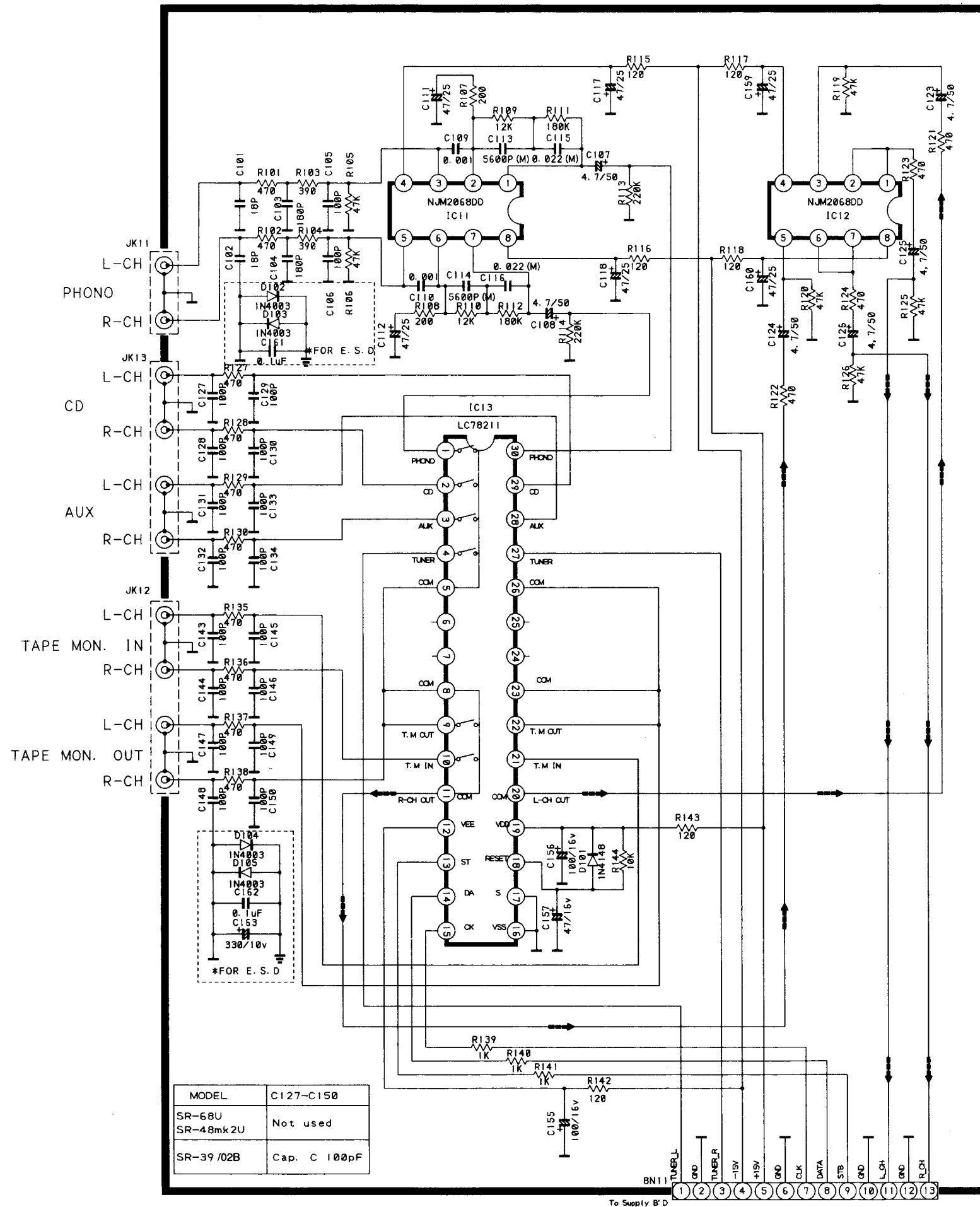

INPUT BOARD

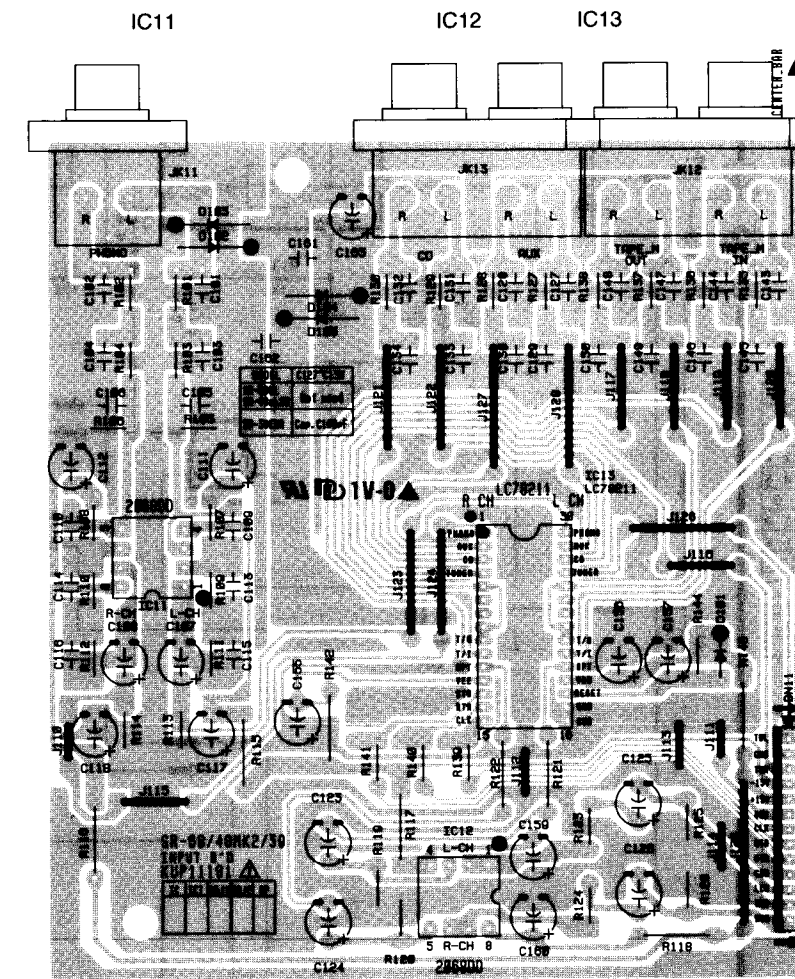

POWER AMP SCHEMATIC DIAGRAM

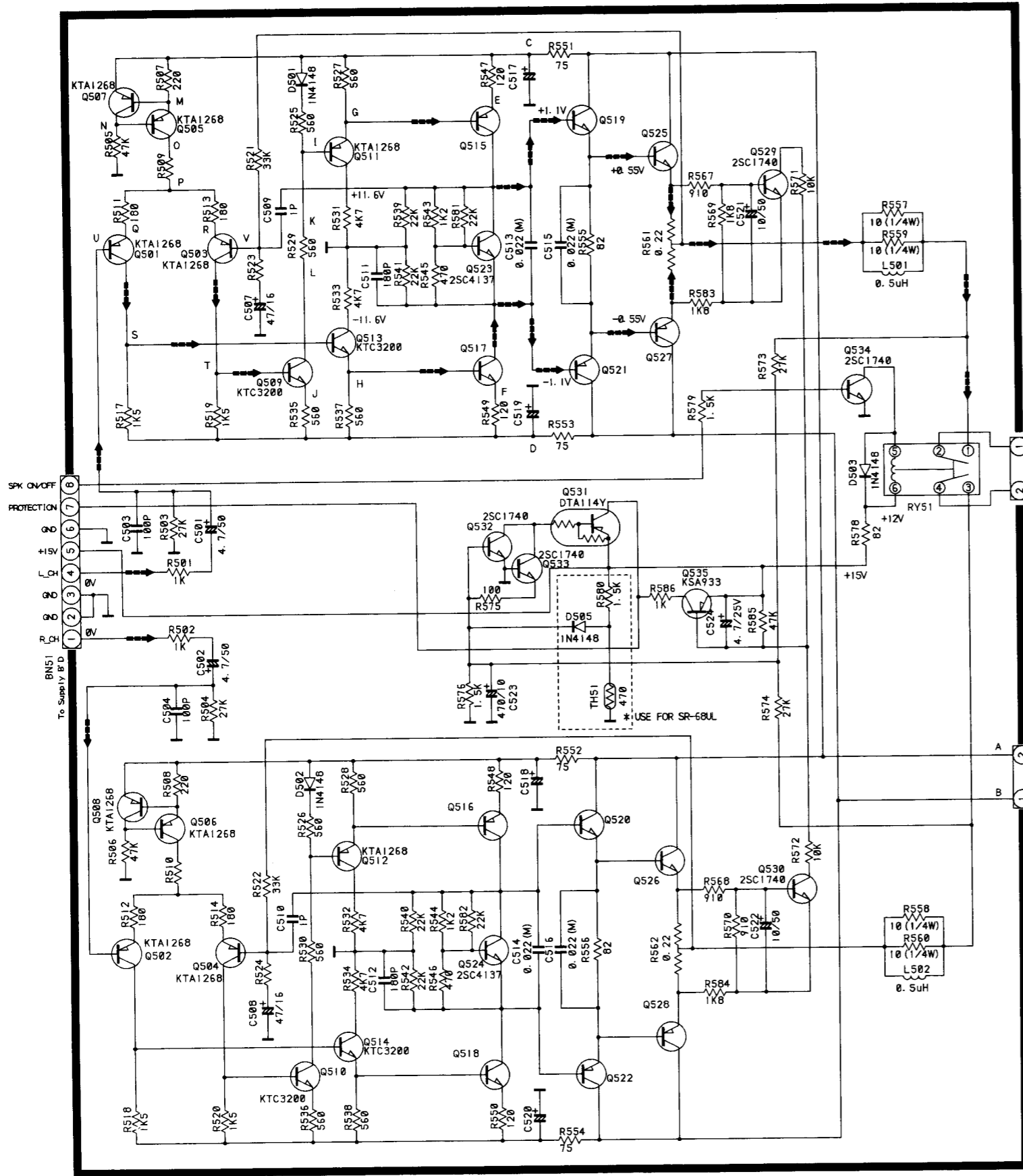

* VOLTAGE OF MODELS

POINT	SR-68U	SR-48mk2U	SR-39/02B
A	+48.6V	+41.4V	+36V
B	-48.6V	-41.4V	-36V
C	+47.7V	+40.2V	+35V
D	-47.7V	-40.2V	-35V
E	+47V	+39.3V	+34.2V
F	-47V	-39.3V	-34.2V
G	+46.5V	+38.7V	+33.6V
H	-46.5V	-38.7V	-33.6V
I	+47V	+39.3V	+34.3V
J	-46.5V	-38.7V	-33.6V
K	+46V	+38.5V	+33V
L	+44.6V	+37V	+31.8V
M	+47V	+40V	+34.3V
N	+46.5V	+38.6V	+33.7V
O	+46.5V	+26.9V	+26.6V
P	+0.8V	+0.8V	+0.8V
Q	+0.6V	+0.6V	+0.6V
R	+0.6V	+0.6V	+0.6V
S	-46V	-38V	-33V
T	-46V	-38V	-33V
U	+100mV	+100mV	+100mV
V	+140mV	+126mV	+126mV

MODEL	Q515-516	Q517-518	Q519-520	Q521-522	C517-C520	Q525-526	Q527-528	R509-510	R523-524	RY51
SR-68U	2SA1360	2SC3423	2SD1763A	2SB1186A	470uF 63V	2SC4468	2SA1695	18K	1K5	OSA-SS-212DM5
SR-48MK2U	KSA910Y	KSC2310Y	2SD1763A	2SB1186A	470uF 50V	2SC4467	2SA1694	10K	1K8	OSA-SS-212DM3
SR-39/02B	KSA910Y	KSC2310Y	KSC2316	KSA916	470uF 50V	2SC4466	2SA1693	10K	2K2	OSA-SS-212DM3

POWER AMP BOARD

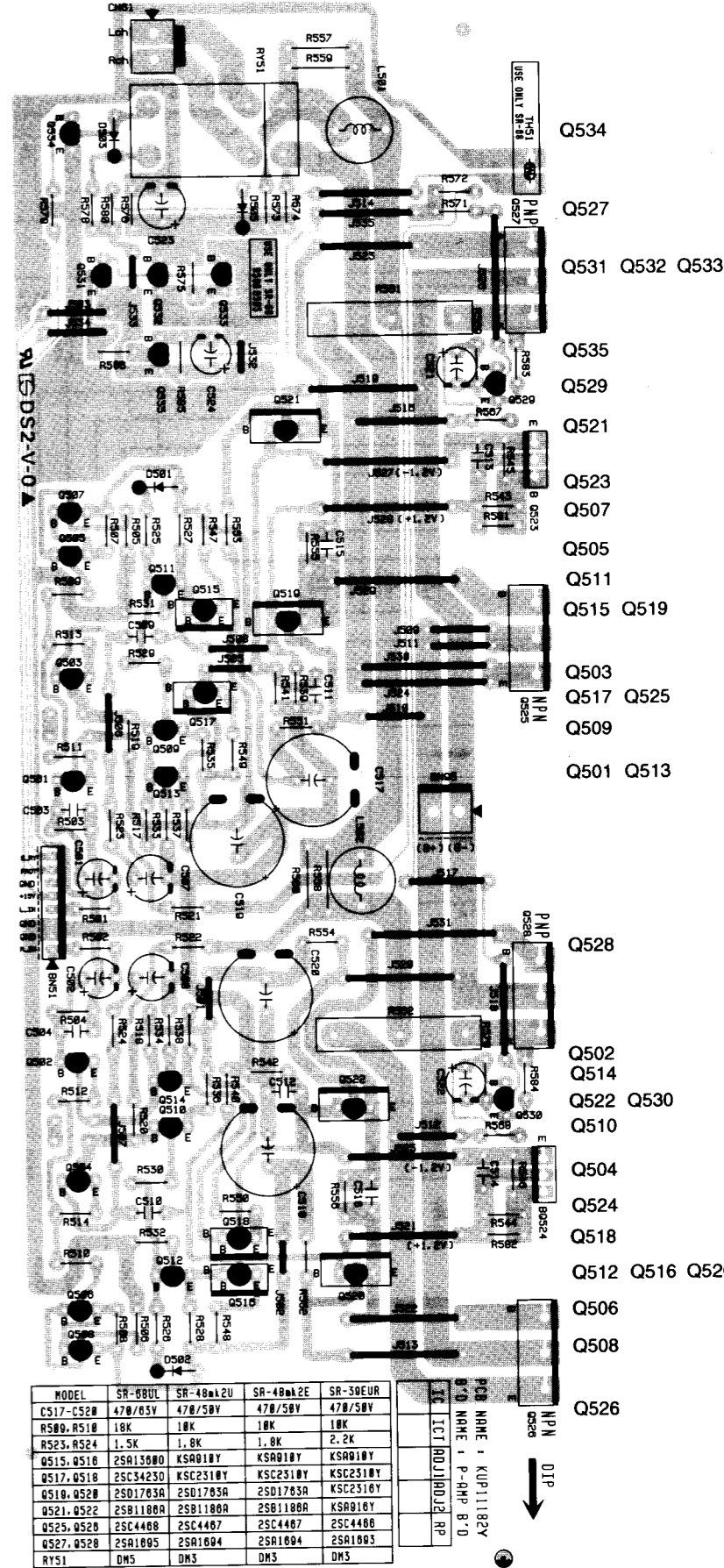

MODEL	SR-68U	SR-48mk2U	SR-48mk2E	SR-39EUR
C517-C520	470/63V	470/50V	470/50V	470/50V
R509, R510	18K	18K	18K	18K
R523, R524	1.5K	1.8K	1.8K	2.2K
Q515, Q516	2SA1360	KSA910Y	KSA910Y	KSA910Y
Q517, Q518	2SC3423	KSC2310Y	KSC2310Y	KSC2310Y
Q519, Q520	2SD1763A	2SD1763A	2SD1763A	KSC2310Y
Q521, Q522	2SB1186A	2SB1186A	2SB1186A	KSA910Y
Q525, Q526	2SC4468	2SC4467	2SC4467	2SC4468
Q527, Q528	2SA1695	2SA1694	2SA1694	2SA1693
RY51	DM5	DM3	DM3	DM3

POWER SUPPLY SCHEMATIC DIAGRAM

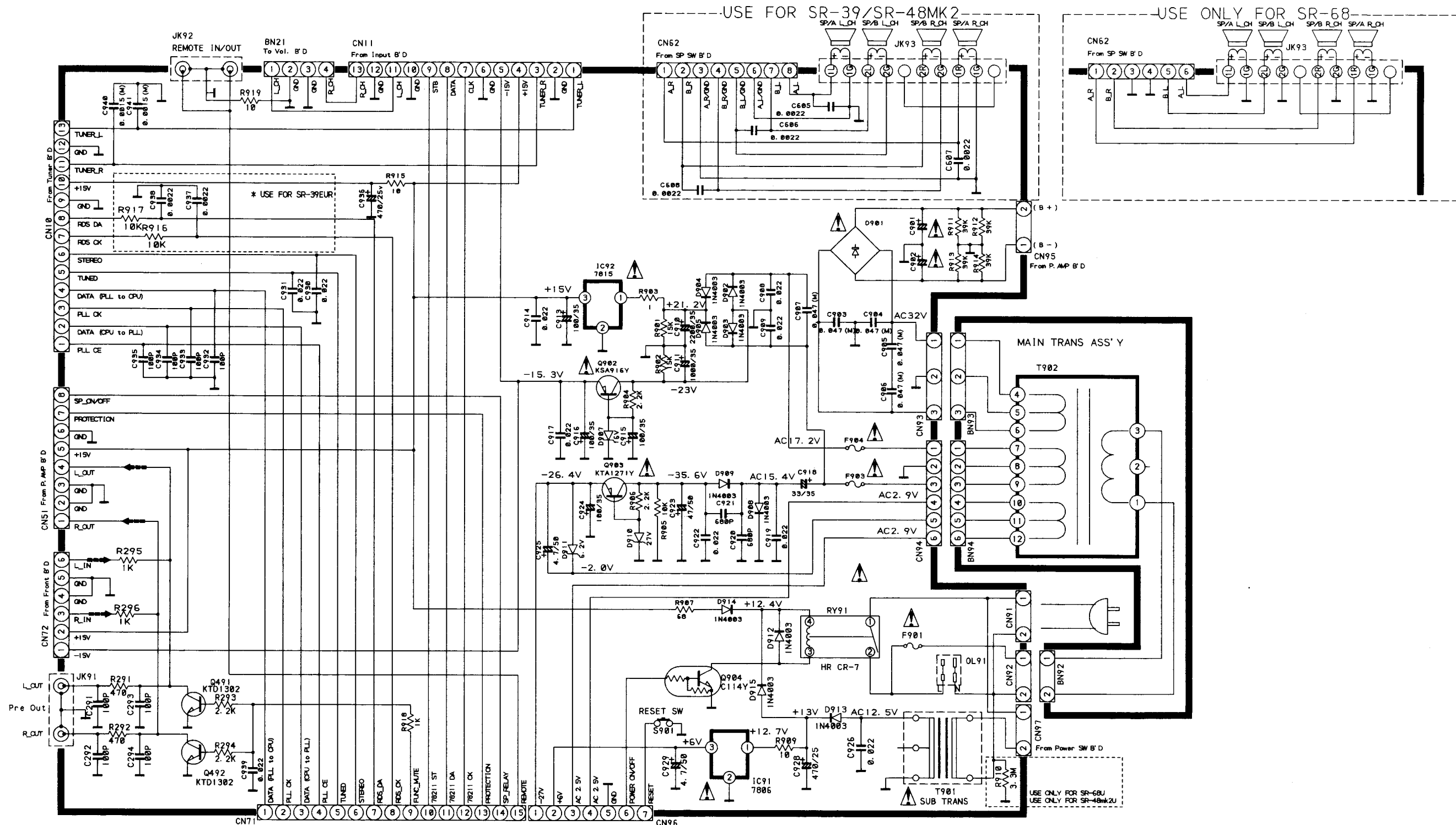

* OPTION OF THE MODEL

MODEL	R910	C291 - C294	C605 - C608	F901	F903 - F904	D901	C901, C902
SR-68U	3M3 1/2W	Not used	Not used	SB 5A 250V	SB 1.25A 250V	KBJ604G	8200uF 63V
SR-48MK2U	3M3 1/2W	Not used	Not used	SB 4A 250V	SB 1.25A 250V	KBJ404G	6800uF 50V
SR-39/02B	Not used	Cap. C 100pF	Cap. C 0.0022uF	T 1.6A 250V	T 1A 250V	KBJ404G	4700uF 50V

*** IMPORTANT SAFTY NOTICE :**

COMPONENTS IDENTIFIED BY MARK HAVE SPECIAL CHARACTERISTICS. IMPORTANT FOR SAFTY, WHEN REPLACING ANY OF THESE COMPONENTS USE ONLY MANUFACTURER'S SPECIFIED PART.

* THE UNIT OF RESISTANCE IS OHM, K=1000 OHM, M=1000 KOHM.

* THE CAPACITANCE IS MICROFARAD P=PICO FARAD

* THIS SCHEMATIC DIAGRAM MAY BE MODIFIED AT ANY TIME WITH THE IMPROVEMENT OF PERFORMANCE.

* ALL VOLTAGE ARE MEASURED WITH GROUND.
DC: VALUES WITH NO SINGAL
AC: RMS

POWER SUPPLY BOARD

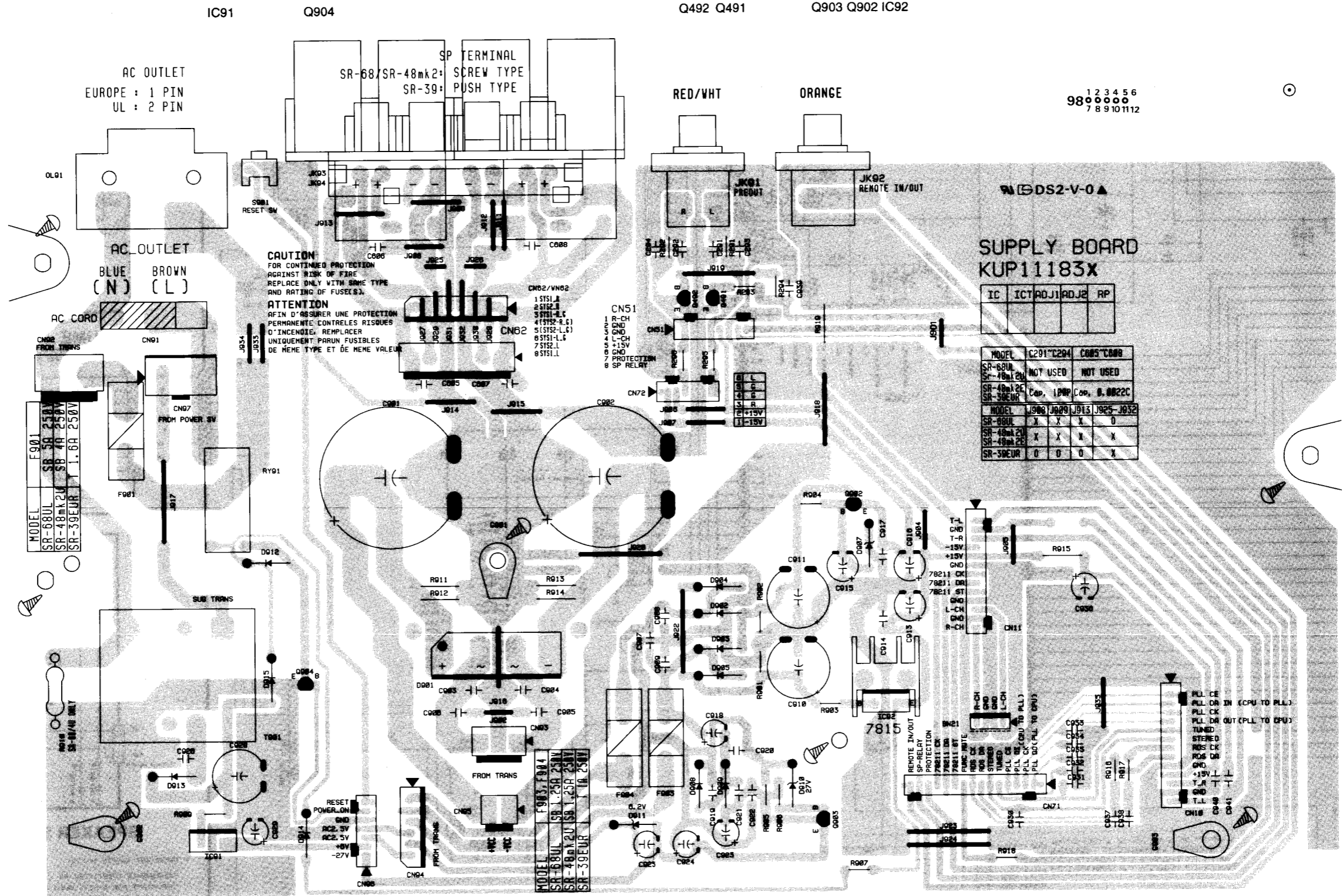

FRONT SCHEMATIC DIAGRAM

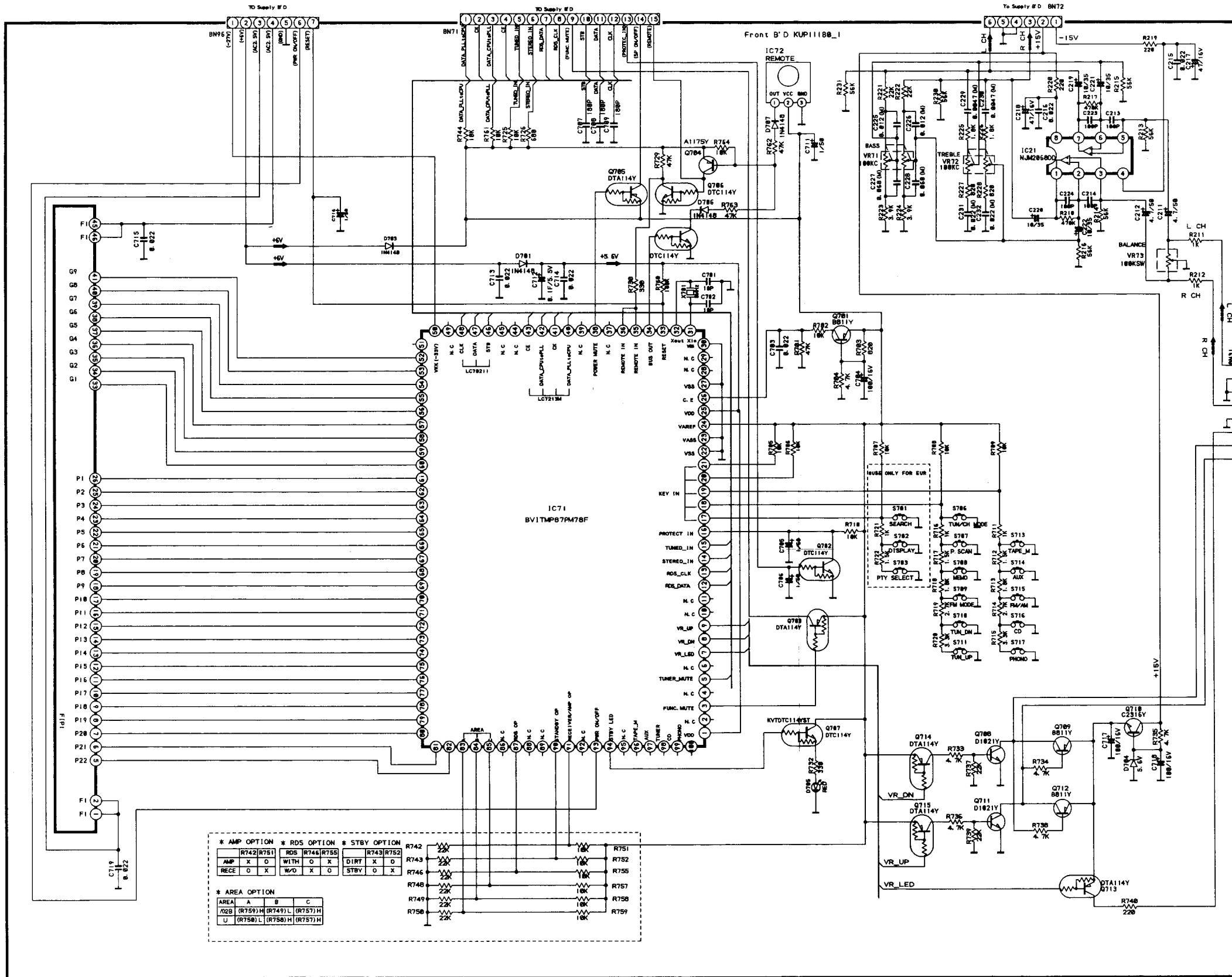

SPEAKER SW & HEADPHONE

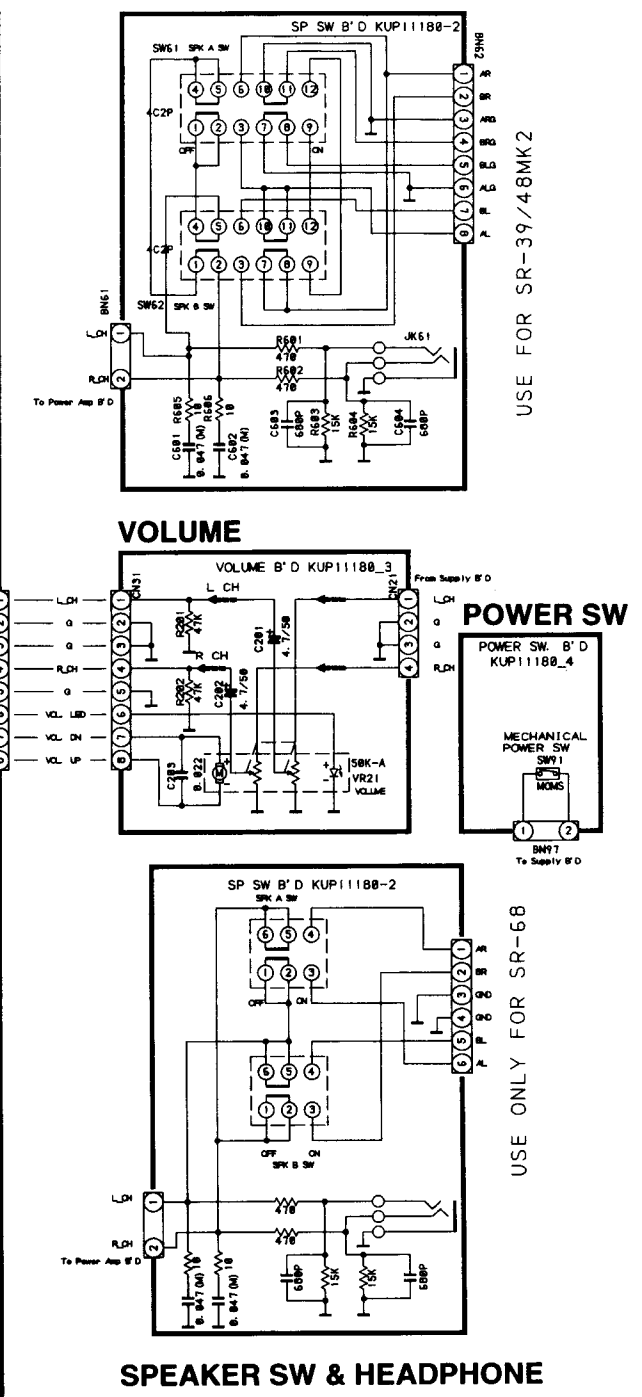

* IMPORTANT SAFETY NOTICE :
 COMPONENTS IDENTIFIED BY Δ MARK HAVE SPECIAL CHARACTERISTICS. IMPORTANT FOR SAFETY, WHEN REPLACING ANY OF THESE COMPONENTS USE ONLY MANUFACTURER'S SPECIFIED PART.

* THE UNIT OF RESISTANCE IS OHM, K=1000 OHM, M=1000 KOHM.
 * THE CAPACITANCE IS MICROFARAD P=PICO FARAD
 * THIS SCHEMATIC DIAGRAM MAY BE MODIFIED AT ANY TIME WITH THE IMPROVEMENT OF PERFORMANCE.
 * ALL VOLTAGE ARE MEASURED WITH GROUND.
 DC: VALUES WITH NO SIGNAL
 AC: RMS

FRONT BOARD

IC72

Q707 Q705
Q716 Q704 Q706

IC71

Q701

Q710 Q702 Q703

Q708 Q709
Q714 Q715 Q712 Q713
IC21

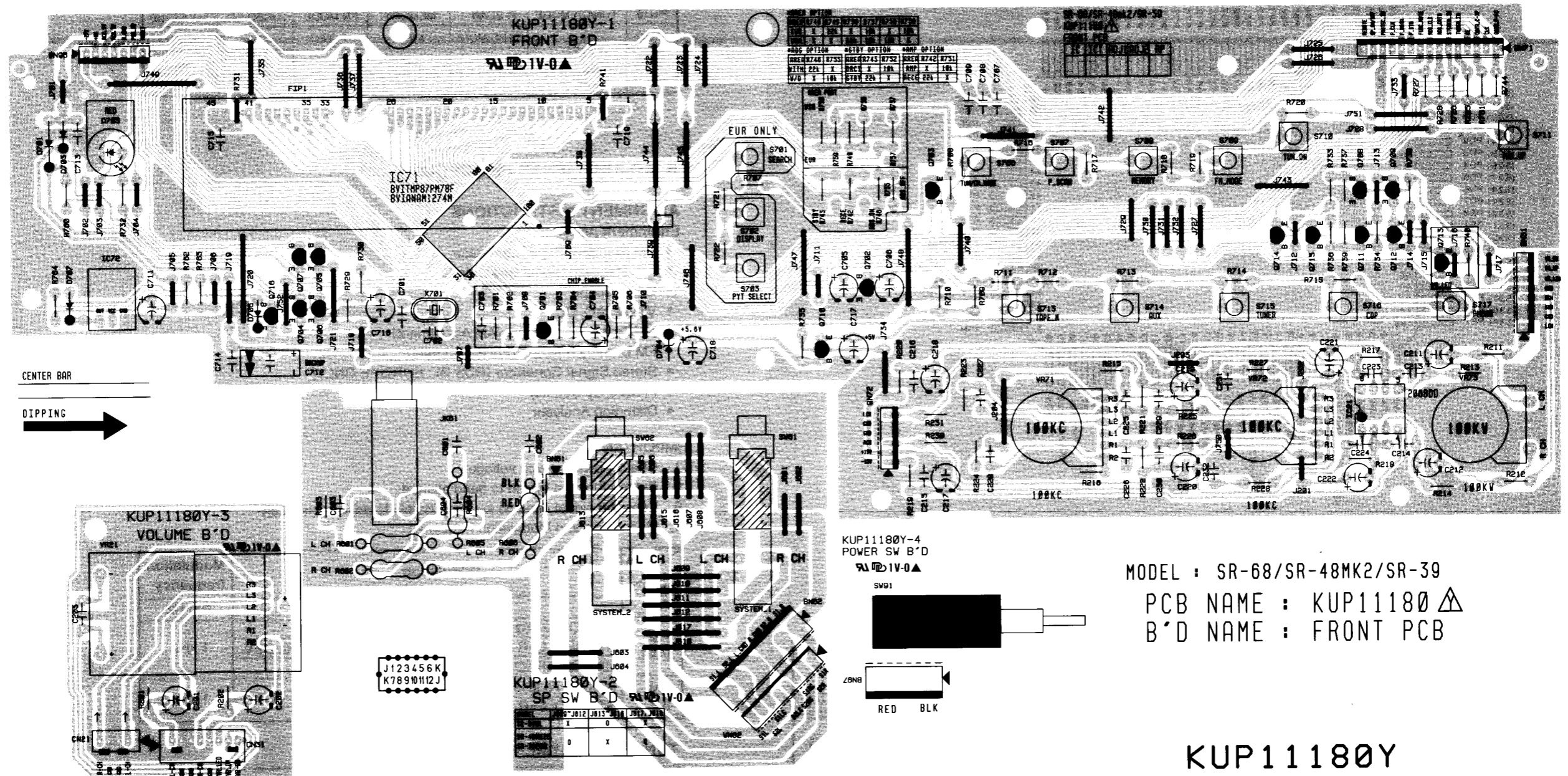

CENTER BAR
DIPPING →

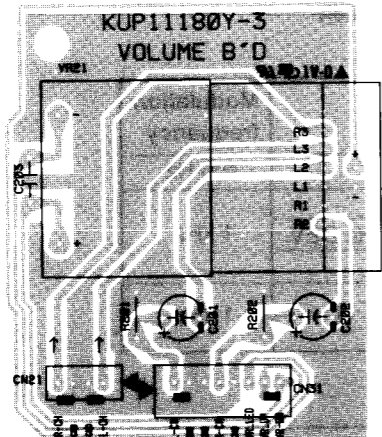

VOLUME

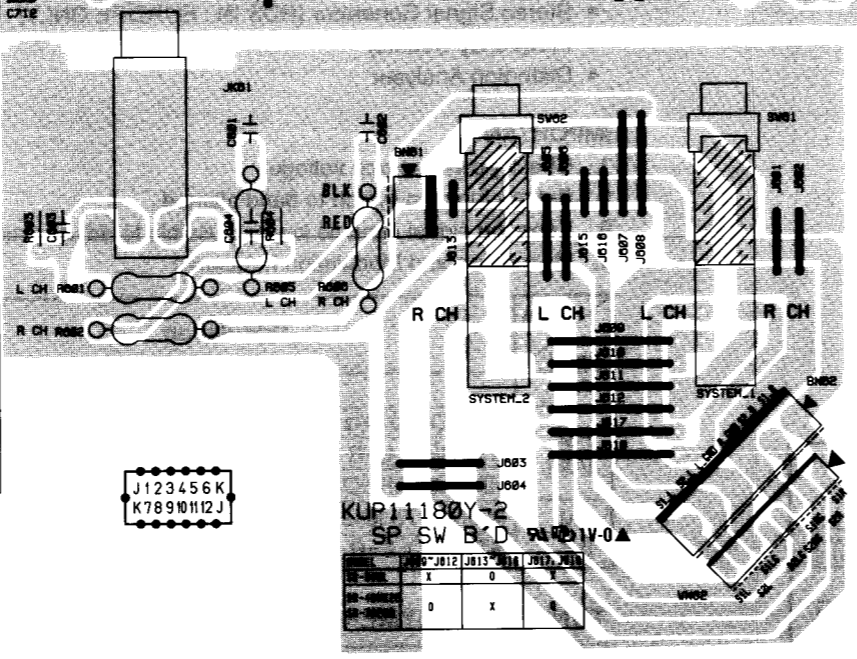

SPEAKER SW & HEADPHONE

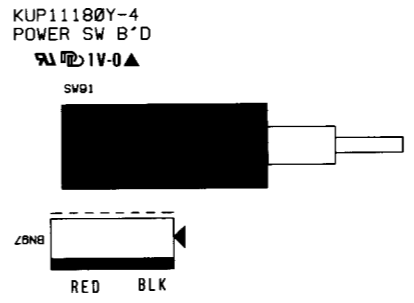

POWER SWITCH

MODEL : SR-68/SR-48MK2/SR-39
PCB NAME : KUP11180 Δ
B'D NAME : FRONT PCB

KUP11180Y

5. MICROPROCESSOR DESCRIPTIONS

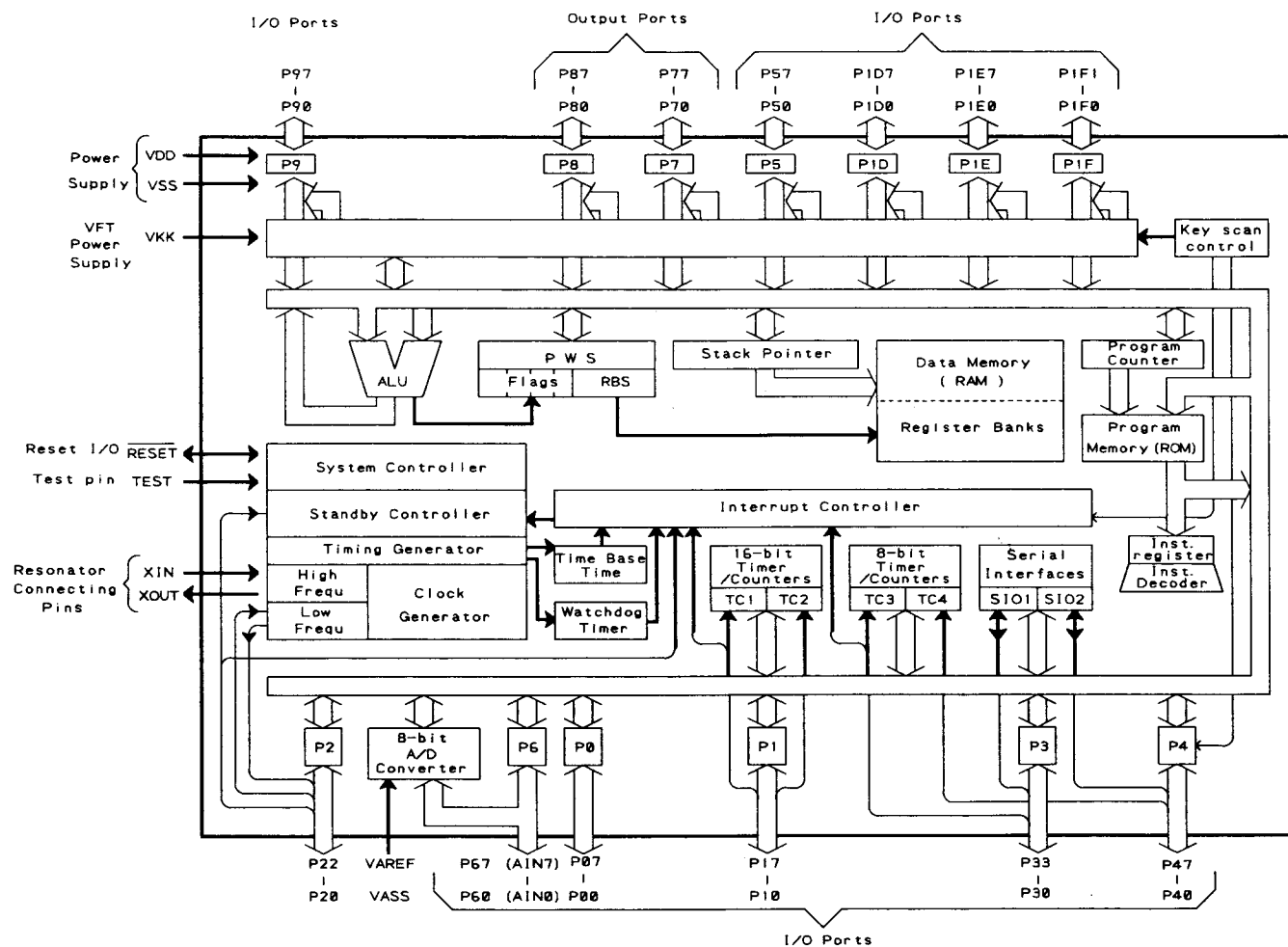
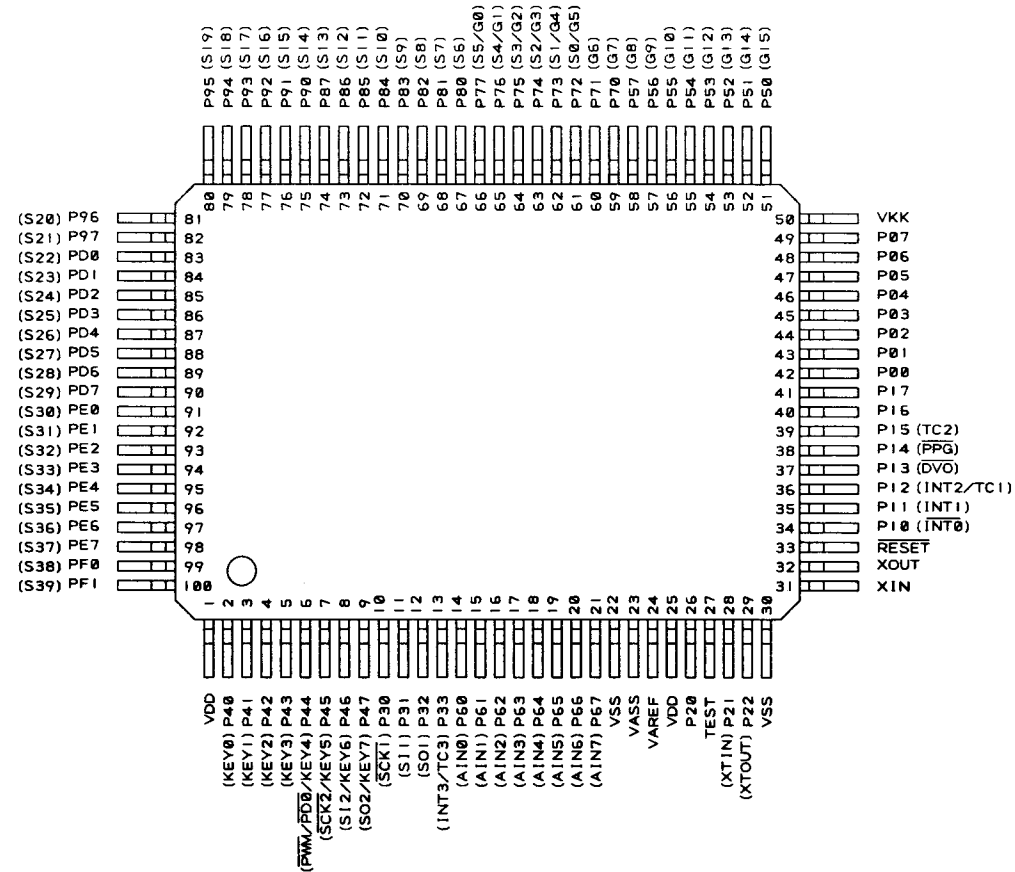

Key Matrix

I/O	—	1 kohm	1.5 kohm	1.8 kohm	2.7 kohm	3.3 kohm
PIN17	SEARCH	DISPLAY	PTY SELECT	—	—	—
PIN18	TUN/CH MODE	P. SCAN	MEMORY	FM MODE	TUNED-DN	TUNED-UP
PIN19	—	TAPE-MONI	AUX	FM/AM	CD	PHONO
PIN20	—	—	—	—	—	—
PIN21	—	—	—	—	—	—

6. ADJUSTMENTS PROCEDURE

ALIGNMENT INSTRUCTIONS

Equipment needed:

- AM Standard Signal Generator
- FM Standard Signal Generator
- Oscilloscope
- VTVM (AC, DC)
- AM Test Loop Antenna (AM Adjustment)
- FM Dummy Antenna (FM Adjustment)
- Stereo Signal Generator (RDS IN : EUROPE ONLY)
- Frequency Counter
- Distortion Analyser

IMPORTANT

1. Check power-source voltage.
2. Set the function switch to band aligned.
3. Keep the signal input as low as possible to adjust accurately.
4. Modulation and Modulation frequency.

Item	Modulation	Modulation frequency
Band	30 %	400 Hz
AM	MONO: 40 kHz DEV.	1 kHz
FM [02]	STEREO: L=R (40 kHz), PILOT (7.5 kHz) 47.5 kHz DEV.	
FM [U]	RDS: STEREO + RDS (1.2 kHz) 48.7 kHz DEV.	
FM [U]	MONO: 75 kHz DEV. (100 %)	1 kHz
FM [U]	STEREO: L=R (67.5 kHz), PILOT (7.5 kHz)	

TUNER ADJUSTMENT POINT

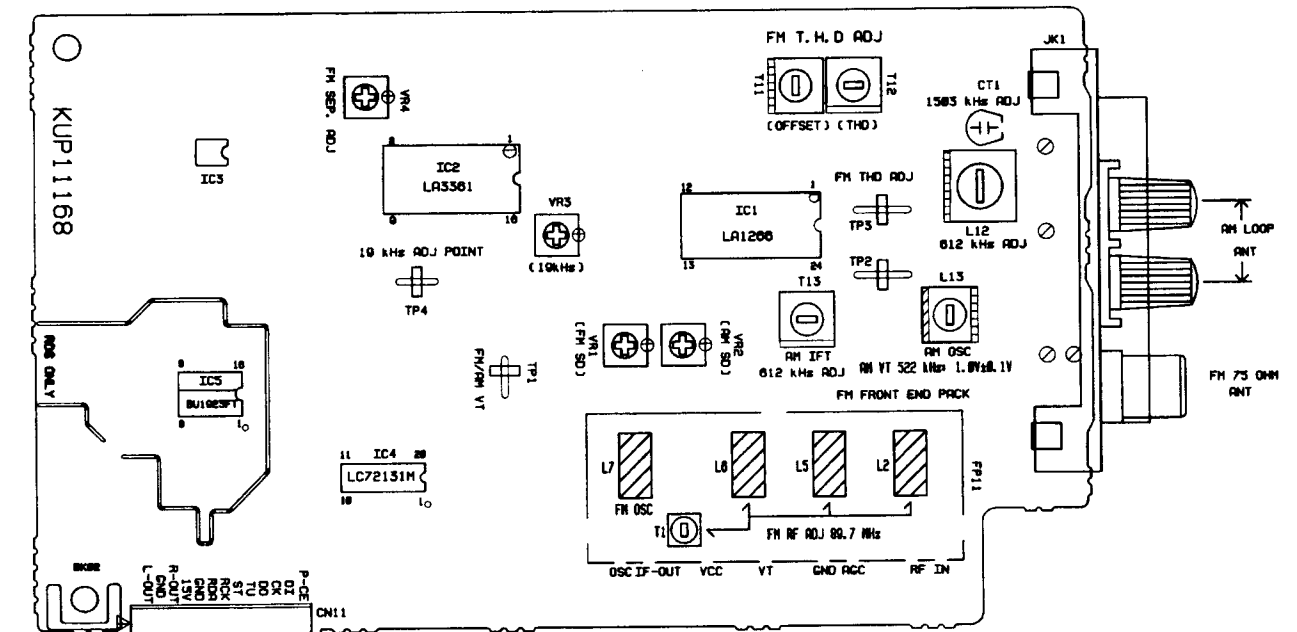

(1) FM, AM TRACKING VOLTAGE ADJUSTMENT
 AM, FM DC Voltmeter -- Connect to test point TP1 and GND

No	Band	Frequency	Adjust for	Adjustment
1	FM	87.50 MHz	1.6 V	L7
2	AM	522 kHz	1.0 V	L13
	AM	530 kHz	1.0 V	L13

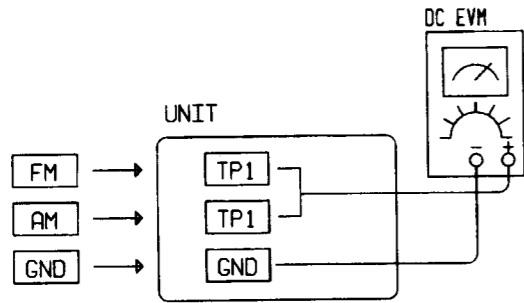

(2) AM RF ADJUSTMENT

Signal Generator ---- Connect to the AM Ant. Coil through the loop antenna.
 Adjust for indication of VTVM of the wave form of scope to be maximum.

[/02 Version]

Band	Step	Frequency	Adjust for	Adjustment
AM	1	612 kHz	Maximum sens.	L12, T13
	2	1503 kHz	Maximum sens.	CT1
	3	Repeat steps 1 and 2 several times		

[U Version]

Band	Step	Frequency	Adjust for	Adjustment
AM	1	610 kHz	Maximum sens.	L12, T13
	2	1510 kHz	Maximum sens.	CT1
	3	Repeat steps 1 and 2 several times		

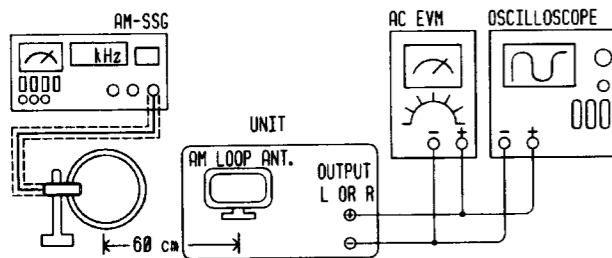

(3) FM RF ADJUSTMENT

Signal Generator ---- Connect to FM Ant. (FM 75 ohm) through the dummy.
 Adjust for indication of VTVM of the wave form of scope to be maximum.

Band	Step	Frequency	Adjust for	Adjustment
FM	1	90.10 MHz	Maximum sens.	L2, L5, L6, T1
	2	Repeat step 1 several times		

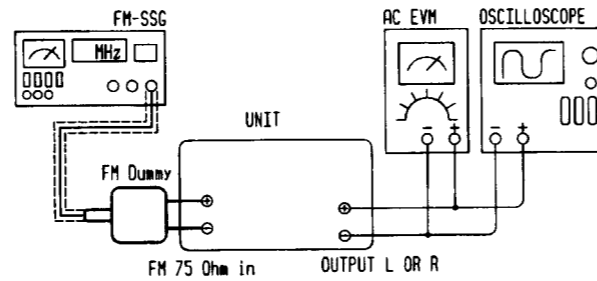

(4) FM MONO DISTORTION ADJUSTMENT

Signal Generator ---- Connect to FM Ant. (FM 75 ohm) through the dummy.
 DC Voltmeter ---- Connect to TP2(+), TP3(-) through the choke coil (100μH)
 Distortion Meter ----- Connect to output L or R

Band	Step	Frequency	Adjust for	Adjustment
FM	1	100.50 MHz	DC Volt 0V	T11
	2	100.50 MHz	Minimum T.H.D	T12
	3	Repeat steps 1 and 2 several times		

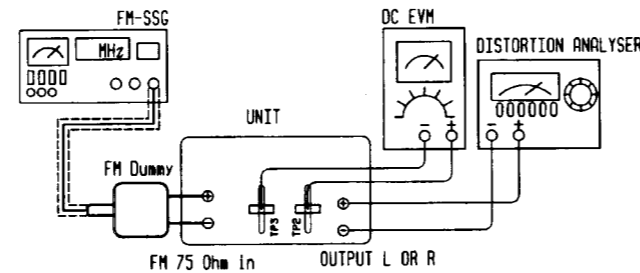

(5) FM MPX VCO ADJUSTMENT

Signal Generator ---- Connect to FM Ant. (FM 75 ohm) through the dummy.

Band	Frequency	SSG Condition	Adjust for	Adjustment
FM	100.50 MHz	Modulation ----- 0 %	19.00 kHz + 30 Hz	VR3
		Modulation Frequency ---- 0 Hz		
		Output Level ----- 66 dB		

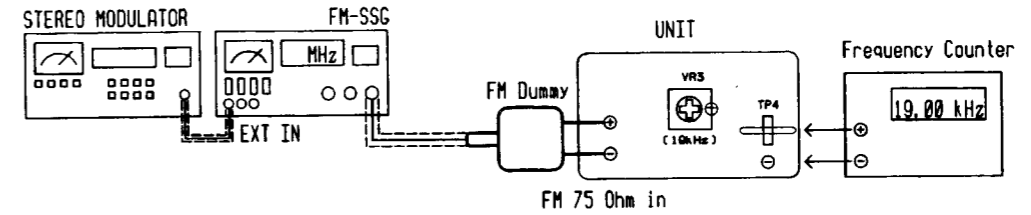

(6) FM STEREO SEPARATION ADJUSTMENT

Signal Generator ---- Connect to FM Ant. (FM 75 ohm) through the dummy.

Band	Frequency	SSG Condition	Adjust for	Adjustment
FM	100.50 MHz	Modulation ----- L or R only	Different of R or L must be maximum	VR4
		Modulation Frequency ---- 1 kHz		
		Output Level ----- 66 dB		

NOTE: In case of adjusting the stereo separation of input is L(or R) channel, R(or L) channel must be maximum.

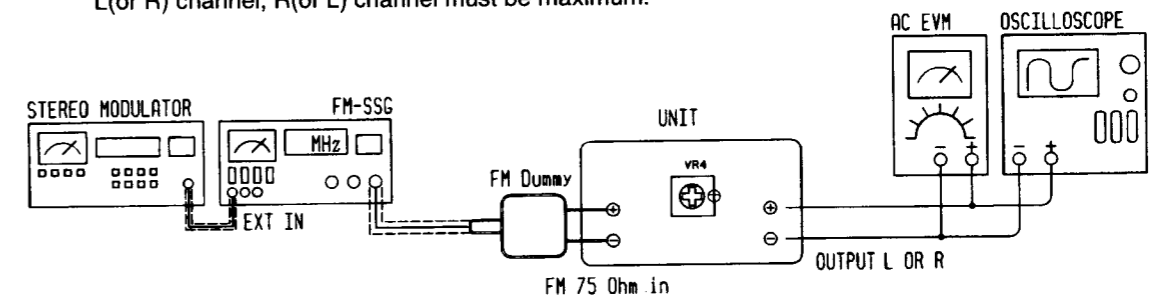

(7) AM, FM AUTO STOP LEVEL ADJUSTMENT

Signal Generator ---- Connect to FM Ant. (FM 75 ohm) through the dummy.
 ---- Connect to the AM Ant. Coil through the loop antenna.

Band	Step	Frequency and Level	Adjust for	Adjustment
FM	1	100.50 MHz, 30 dB	(TUNED) Display off	VR1
	2	100.50 MHz, 30 dB	(TUNED) Display on	VR1
AM	1	990 kHz, 80 dB	(TUNED) Display off	VR2
	2	990 kHz, 80 dB	(TUNED) Display on	VR2

7. EXPLODED VIEW AND PARTS LIST (SR-68/SR-48mk2)

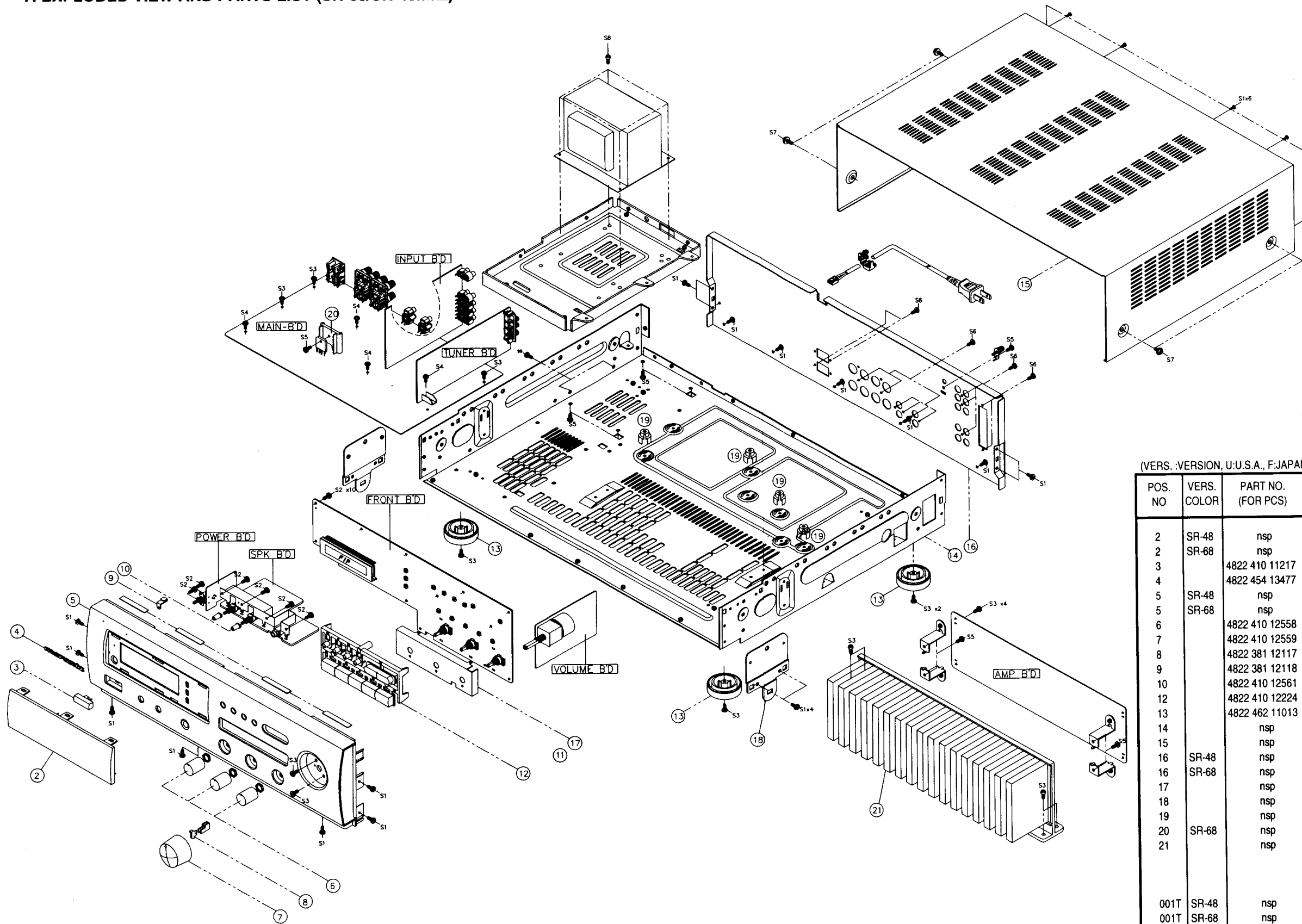

(VERS.: VERSION, U:U.S.A., F:JAPAN, K:FAR EAST, *:EUROPE)

POS. NO	VERS. COLOR	PART NO. (FOR PCS)	DESCRIPTION	PART NO. (MJI)
2	SR-48	nsp	WINDOW	236W158010
2	SR-68	nsp	WINDOW	236W158010
3		4822 410 11217	POWER KNOB	168W270090
4		4822 454 13477	BADGE	243W251010
5	SR-48	nsp	FRONT PANEL SR-48	236W248030
5	SR-68	nsp	FRONT PANEL SR-68	254W248010
6		4822 410 12558	ROTARY KNOB	254W154020
7		4822 410 12559	VOLUME KNOB	254W154010
8		4822 381 12117	VOL. INDICATOR	254W355010
9		4822 381 12118	LED INDICATOR	254W355020
10		4822 410 12561	SPEAKER KNOB	254W270010
12		4822 410 12224	FUNCTION BUTTON	236W270010
13		4822 462 11013	FOOT	243W057010
14		nsp	BOTTOM CHASSIS	nsp
15		nsp	TOP CABINET	nsp
16	SR-48	nsp	REAR PANEL	nsp
16	SR-68	nsp	REAR PANEL	nsp
17		nsp	SHIELD COVER	nsp
18		nsp	CHASSIS BRACKET	nsp
19		nsp	SHAFT BRACKET	nsp
20	SR-68	nsp	DIODE HEAT SINK	nsp
21		nsp	HEAT SINK	nsp
PACKING				
001T	SR-48	nsp	USER GUIDE (DFU)	266W851250
001T	SR-68	nsp	USER GUIDE (DFU)	266W851250
Z002	SR-48	nsp	REMOTE CONTROLER (RC480SR)	ZK237W0010
Z002	SR-68	nsp	REMOTE CONTROLER (RC480SR)	ZK237W0010

8. EXPLODED VIEW AND PARTS LIST (SR-39)

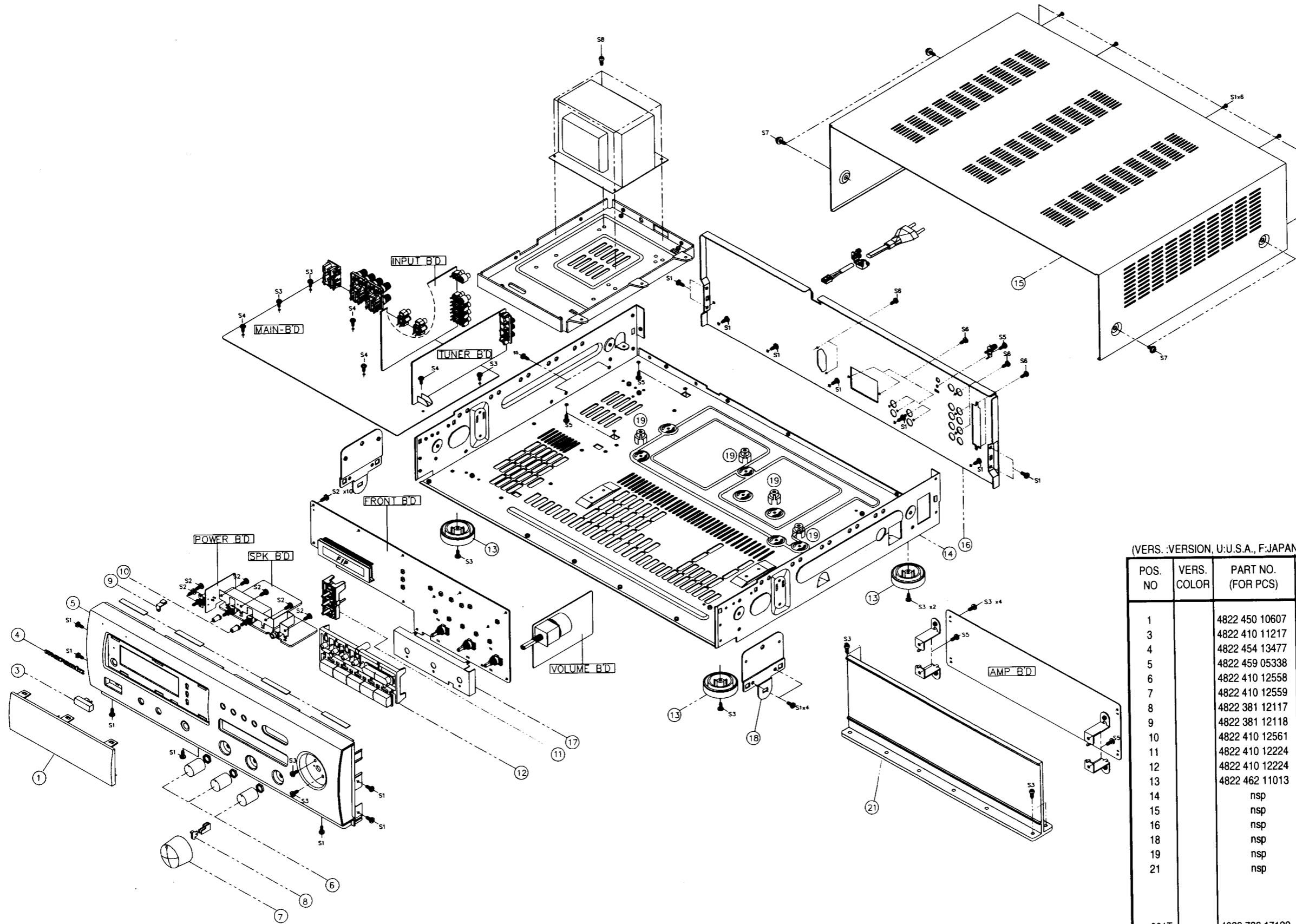

(VERS.:VERSION, U:U.S.A., F:JAPAN, K:FAR EAST, ...EUROPE)

POS. NO	VERS. COLOR	PART NO. (FOR PCS)	DESCRIPTION	PART NO. (MJI)
1		4822 450 10607	WINDOW (RDS)	236W158020
3		4822 410 11217	POWER KNOB	168W270090
4		4822 454 13477	BADGE	243W251010
5		4822 459 05338	FRONT PANEL SR-39	266W248010
6		4822 410 12558	ROTARY KNOB	254W154020
7		4822 410 12559	VOLUME KNOB	254W154010
8		4822 381 12117	VOL. INDICATOR	254W355010
9		4822 381 12118	LED INDICATOR	254W355020
10		4822 410 12561	SPEAKER KNOB	254W270010
11		4822 410 12224	3KEY BUTTON	236W270020
12		4822 410 12224	FUNCTION BUTTON	236W270010
13		4822 462 11013	FOOT	243W057010
14		nsp	BOTTOM CHASSIS	nsp
15		nsp	TOP CABINET	nsp
16		nsp	REAR PANEL	nsp
18		nsp	CHASSIS BRACKET	nsp
19		nsp	SHAFT BRACKET	nsp
21		nsp	HEAT SINK	nsp
001T		4822 736 17122	PACKING USER GUIDE (DFU)	266W851310
Z002		4822 219 10067	REMOTE CONTROLLER (RC66PM)	ZK432W0010

(VERS.:VERSION, U:U.S.A., F:JAPAN, K:FAR EAST, **:EUROPE)

POS. NO	VERS. COLOR	PART NO. (FOR PCS)	DESCRIPTION	PART NO. (MUJ)
R760		nsp	100k Ω 1/5W J	nsp
R761		nsp	10k Ω 1/5W J	nsp
R762		nsp	4.7k Ω 1/5W J	nsp
R763		nsp	4.7k Ω 1/5W J	nsp
R764		nsp	10k Ω 1/5W J	nsp
VR21		4822 101 11969	VR MOTOR EUWM2 F25A54	*RY000030R
VR71		4822 101 11971	VARIABLE 100K-C	*RA000900R
VR72		4822 101 11971	VARIABLE 100K-C	*RA000900R
VR73		4822 101 11972	VARIABLE 100K-SW	*RA000890R
			SWITCH	
S701	SR-39	4822 276 13541	TACT SW EVQ21505R	*SP000840R
S702	SR-39	4822 276 13541	TACT SW EVQ21505R	*SP000840R
S703	SR-39	4822 276 13541	TACT SW EVQ21505R	*SP000840R
S706				
S711		4822 276 13541	TACT SW EVQ21505R	*SP000840R
S713				
S717		4822 276 13541	TACT SW EVQ21505R	*SP000840R
			MISCELLANEOUS	
FIP1		4822 135 00294	FLD SVA09MS10	*HQ300350R
X701		4822 242 10855	CRYSTAL 8MHz	*JX000410R
			SPK SW.& HEADPHONE CIRCUIT BOARD CAPACITOR	
C601		nsp	MYLAR 0.047 μ F 50V J	nsp
C602		nsp	MYLAR 0.047 μ F 50V J	nsp
C603		nsp	CER. 680pF 50V K	nsp
C604		nsp	CER. 680pF 50V K	nsp
			RESISTOR	
R601		4822 053 10471	470 Ω 1W METAL	GA05471010
R602		4822 053 10471	470 Ω 1W METAL	GA05471010
R603		nsp	15k Ω 1/5W J	nsp
R604		nsp	15k Ω 1/5W J	nsp
R605		4822 053 10109	10 Ω 1W METAL	GA05100010
R606		4822 053 10109	10 Ω 1W METAL	GA05100010
			SWITCH	
SW61	SR-39	4822 276 14104	PUSH SW (4C2P)	*SP000870R
	SR-48		SPUL19X1M081	
SW61	SR-68	nsp	PUSH SW SPUL19X1M071	*SP000860R
SW62	SR-39	4822 276 14104	PUSH SW (4C2P)	*SP000870R
	SR-48		SPUL19X 1M081	
SW62	SR-68	nsp	PUSH SW SPUL19X1M071	*SP000860R
			MISCELLANEOUS	
JK61		4822 265 11649	JACK HEADPHONE HTJ064-11DG	*YT001610R
			POWER SW. CIRCUIT BOARD SWITCH	
SW91		4822 276 14105	PUSH SW (MOMS)	*SP000850R
			VOLUME CIRCUIT BOARD CAPACITOR	
C201		nsp	ELECT 4.7 μ F 50V	nsp
C202		nsp	ELECT 4.7 μ F 50V	nsp
C203		nsp	CER. 0.022 μ F 25V Z	nsp
			RESISTOR	
R201		nsp	47k Ω 1/5W J	nsp
R202		nsp	47k Ω 1/5W J	nsp

(VERS.:VERSION, U:U.S.A., F:JAPAN, K:FAR EAST, **:EUROPE)

POS. NO	VERS. COLOR	PART NO. (FOR PCS)	DESCRIPTION	PART NO. (MUJ)
			TUNER CIRCUIT BOARD CAPACITOR	
			VARIABLE CAP	*CT000110R
CT01		4822 125 11116		
C011	SR-39	nsp	CER. 15pF 50V J	nsp
C013		nsp	CER. 0.01 μ F 25V Z	nsp
C014		nsp	CER. 1000pF 50V K	nsp
C015		nsp	CER. 15pF 50V J	nsp
C016		nsp	CER. 0.01 μ F 25V Z	nsp
C017		nsp	CER. 10pF 50V J	nsp
C018		nsp	CER. 0.047 μ F 50V Z	nsp
C019		nsp	CER. 0.047 μ F 50V Z	nsp
C020		nsp	ELECT 1.0 μ F 50V	nsp
C021		nsp	ELECT 220 μ F 16V	nsp
C022		nsp	CER. 0.01 μ F 25V Z	nsp
C023		nsp	CER. 100pF 50V K	nsp
C024		nsp	CER. 100pF 50V K	nsp
C025		nsp	CER. 390pF 50V K	nsp
C026	SR-39	nsp	CER. 100pF 50V K	nsp
C027	SR-39	nsp	CER. 100pF 50V K	nsp
C028	SR-39	nsp	CER. 0.1 μ F 50V Z	nsp
C031		nsp	CER. 0.047 μ F 50V Z	nsp
C033		nsp	CER. 15pF 50V J	nsp
C034		nsp	CER. 470pF 50V K	nsp
C036		nsp	CER. 1000pF 50V K	nsp
C037		nsp	ELECT 100 μ F 16V	nsp
C038		nsp	CER. 0.047 μ F 50V Z	nsp
C039		nsp	CER. 0.01 μ F 25V Z	nsp
C040		nsp	CER. 8.2pF 50V K	nsp
C041		nsp	CER. 47pF 50V J	nsp
C042		nsp	ELECT 1.0 μ F 50V	nsp
C043		nsp	ELECT 4.7 μ F 16V	nsp
C045		nsp	ELECT 1 μ F 50V	nsp
C046		nsp	ELECT 1.0 μ F 50V	nsp
C047	SR-39	nsp	CER. 2700pF 16V M	nsp
C047	SR-48	nsp	CER. 6800pF 16V M	nsp
C047	SR-68	nsp	CER. 6800pF 16V M	nsp
C048		nsp	MYLAR 1500pF 50V J	nsp
C050	SR-39	nsp	MYLAR 0.015 μ F 50V J	nsp
C050	SR-48	nsp	MYLAR 0.022 μ F 50V J	nsp
C050	SR-68	nsp	MYLAR 0.022 μ F 50V J	nsp
C051		nsp	ELECT 0.47 μ F 50V	nsp
C054		nsp	ELECT 10 μ F 16V	nsp
C055		nsp	ELECT 100 μ F 16V	nsp
C056		nsp	CER. 0.047 μ F 50V Z	nsp
C057		nsp	CER. 1000pF 50V K	nsp
C058		nsp	MYLAR 1000pF 50V J	nsp
C059		nsp	ELECT 0.47 μ F 50V	nsp
C060		nsp	ELECT 0.47 μ F 50V	nsp
C061		nsp	ELECT 1.0 μ F 50V	nsp
C063	SR-39	nsp	MYLAR 0.022 μ F 50V J	nsp
C063	SR-48	nsp	MYLAR 0.033 μ F 50V J	nsp
C063	SR-68	nsp	MYLAR 0.033 μ F 50V J	nsp
C064	SR-39	nsp	MYLAR 0.022 μ F 50V J	nsp
C064	SR-48	nsp	MYLAR 0.033 μ F 50V J	nsp
C064	SR-68	nsp	MYLAR 0.033 μ F 50V J	nsp
C065		nsp	ELECT 10 μ F 16V	nsp
C066		nsp	ELECT 10 μ F 16V	nsp
C067		nsp	ELECT 2.2 μ F 50V	nsp
C068		nsp	ELECT 2.2 μ F 50V	nsp
C069		nsp		
			ELECT 10 μ F 35V	nsp
C072		nsp	ELECT 100 μ F 16V	nsp
C073		nsp	ELECT 100 μ F 16V	nsp
C074		nsp	ELECT 470 μ F 10V	nsp
C076		nsp	CER. 0.01 μ F 25V Z	nsp
C077		nsp	CER. 33pF 50V J	nsp
C078		nsp	CER. 33pF 50V J	nsp
C079		nsp	CER. 33pF 50V J	nsp

(VERS.:VERSION, U:U.S.A., F:JAPAN, K:FAR EAST, **:EUROPE)

(VERS.:VERSION, U:U.S.A., F:JAPAN, K:FAR EAST, **:EUROPE)

POS. NO	VERS. COLOR	PART NO. (FOR PCS)	DESCRIPTION	PART NO. (MJI)
C080		nsp	CER. 0.022μF 25V Z	nsp
C081		nsp	ELECT 4.7μF 50V	nsp
C082		nsp	CER. 0.022μF 25V Z	nsp
C083	SR-39	nsp	ELECT 100μF 16V	nsp
C084	SR-39	nsp	CER. 0.01μF 25V Z	nsp
C085	SR-39	nsp	ELECT 10μF 35V	nsp
C086	SR-39	nsp	CER. 100pF 50V K	nsp
C087	SR-39	nsp	CER. 0.01μF 25V Z	nsp
C088	SR-39	nsp	CER. 100pF 50V K	nsp
C089	SR-39	nsp	CER. 27pF 50V J	nsp
C090	SR-39	nsp	CER. 33pF 50V J	nsp
C091		nsp	ELECT 100μF 35V	nsp
C092		nsp	ELECT 100μF 16V	nsp
C093		nsp	CER. 0.022μF 25V Z	nsp
CERAMIC FILTER				
CF01		4822 242 11039	SFE10.7MS8H-A-T	*FF100230R
CF02		4822 242 11039	SFE10.7MS8H-A-T	*FF100230R
CF03		4822 242 10853	SFZ450F	FF10045290
DIODE				
D011		4822 130 11681	VARICAP SVC342-L-AA	*HD400160R
D012		4822 130 30621	1N4148	QP13030621
D013		4822 130 30621	1N4148	QP13030621
D014		4822 130 30621	1N4148	QP13030621
D015	SR-39	4822 130 30621	1N4148	QP13030621
D016		4822 130 11631	ZENER 5.6V 1/2W	*HD301630R
D017		4822 130 30621	1N4148	QP13030621
INTEGRATED CIRCUIT				
IC01		4822 209 71785	LA1266	HC10222030
IC02		4822 209 71321	LA3361	*HC104880R
IC03		5322 209 13406	OP AMP NJM2068MD-TE1	*HC104840R
IC04		4822 209 15778	PLL LC72131M	*HC104820R
IC05	SR-39	4822 209 17453	RDS ENCODER BFU1923F	*HC104810R
COIL				
L012		4822 157 11859	COIL AM ANT 2	*LA000090R
L013		4822 157 11484	COIL AM OSC	*LO000060R
L015	SR-39	4822 157 11873	COIL	*LC107220R
L017		4822 157 11487	COIL MPX	*LS000060R
L018		4822 157 11487	COIL MPX	*LS000060R
TRANSISTOR				
Q011		4822 130 63385	KTC3192O	*HT300480R
Q012		4822 130 63385	KTC3192O	*HT300480R
Q013		4822 130 63385	DTA114YS	*HT300480R
Q014		4822 130 63385	DTA114YS	*HT300480R
Q015		4822 130 63659	DTC143TS	*BA000700R
Q016		4822 130 63659	DTC143TS	*BA000700R
Q017		4822 130 61187	DTA144TS	BA10009210
RESISTOR				
R011		nsp	390 Ω 1/5W J	nsp
R012		nsp	150 Ω 1/5W J	nsp
R013		nsp	15k Ω 1/5W J	nsp
R014		nsp	5.6k Ω 1/5W J	nsp
R015		nsp	1.8k Ω 1/5W J	nsp
R016		nsp	820k Ω 1/5W J	nsp
R017		nsp	560 Ω 1/5W J	nsp
R018		nsp	470k Ω 1/5W J	nsp
R019		nsp	270 Ω 1/5W J	nsp
R020		nsp	1.8k Ω 1/5W J	nsp
R021		nsp	15k Ω 1/5W J	nsp
R022		nsp	2.7k Ω 1/5W J	nsp
R023		nsp	15k Ω 1/5W J	nsp
R024		nsp	2.2k Ω 1/5W J	nsp
R025		nsp	100 Ω 1/5W J	nsp
R026		nsp	1k Ω 1/5W J	nsp

POS. NO	VERS. COLOR	PART NO. (FOR PCS)	DESCRIPTION	PART NO. (MJI)
R027		nsp	100 Ω 1/5W J	nsp
R028		nsp	470 Ω 1/4W J	nsp
R029		nsp	150 Ω 1/5W J	nsp
R030		nsp	100k Ω 1/5W J	nsp
R031		nsp	22k Ω 1/5W J	nsp
R032		nsp	82 Ω 1/5W J	nsp
R033		nsp	39k Ω 1/5W J	nsp
R034		nsp	100k Ω 1/5W J	nsp
R035		nsp	10k Ω 1/4W J	nsp
R036		nsp	18k Ω 1/5W J	nsp
R037		nsp	470 Ω 1/5W J	nsp
R038		nsp	5.6k Ω 1/5W J	nsp
R039		nsp	1k Ω 1/5W J	nsp
R040		nsp	100k Ω 1/5W J	nsp
R041		nsp	470 Ω 1/5W J	nsp
R051		nsp	3.3k Ω 1/5W J	nsp
R056		nsp	1k Ω 1/5W J	nsp
R057		nsp	1k Ω 1/5W J	nsp
R060		nsp	330 Ω 1/5W J	nsp
R061		nsp	330 Ω 1/5W J	nsp
R062		nsp	100k Ω 1/5W J	nsp
R063		nsp	100k Ω 1/5W J	nsp
R064		nsp	10k Ω 1/5W J	nsp
R065		nsp	10k Ω 1/5W J	nsp
R066		nsp	10k Ω 1/5W J	nsp
R067		nsp	270 Ω 1/4W J	nsp
R069		nsp	30k Ω 1/5W J	nsp
R070		nsp	30k Ω 1/5W J	nsp
R071		nsp	100k Ω 1/5W J	nsp
R072		nsp	100k Ω 1/5W J	nsp
R080		nsp	1k Ω 1/5W J	nsp
R081		nsp	1k Ω 1/5W J	nsp
R082		nsp	1k Ω 1/5W J	nsp
R083		nsp	1k Ω 1/5W J	nsp
R084		nsp	1k Ω 1/5W J	nsp
R085		nsp	10k Ω 1/5W J	nsp
R086		nsp	560 Ω 1/5W J	nsp
R087		nsp	5.6k Ω 1/5W J	nsp
R088		nsp	10k Ω 1/5W J	nsp
R089		nsp	10 Ω 1/4W J	nsp
R090		nsp	470 Ω 1/5W J	nsp
R093		nsp	3.3k Ω 1/5W J	nsp
R095		nsp	390 Ω 1/4W J	nsp
R096		nsp	22k Ω 1/5W J	nsp
R097		nsp	1 Ω 1/5W J	nsp
VR01		4822 101 11853	RES SEMI FIXED EVNDJAA03B24	*RA000790R
VR02		4822 101 11853	RES SEMI FIXED EVNDJAA03B24	*RA000790R
VR03		4822 101 11956	RES SEMI FIXED EVNDJAA03B14	*RA000880R
VR04		4822 101 11957	RES SEMI FIXED EVNDJAA03B13	*RA000870R
FP11	SR-39	4822 210 10802	TUNER PACK FTA4460H	*AV000060R
FP11	SR-48	nsp	TUNER PACK FTA3508HB	*AV000070R
FP11	SR-68	nsp	TUNER PACK FTA3508HB	*AV000070R
JK01	SR-39	4822 265 11601	TERMINAL.ANT SC0210392N	*YT001500R
JK01	SR-48	nsp	TERMINAL.ANT	*YT001630R
JK01	SR-68	nsp	TERMINAL.ANT	*YT001630R
T011		4822 157 11861	I.F.T FM	*LA000110R
T012		4822 157 11489	I.F.T FM	*LI000070R
T013		4822 157 11862	I.F.T AM	*LA000100R

(VERS.:VERSION, U:U.S.A., F:JAPAN, K:FAR EAST, *:EUROPE)

(VERS.:VERSION, U:U.S.A., F:JAPAN, K:FAR EAST, *:EUROPE)

POS. NO	VERS. COLOR	PART NO. (FOR PCS)	DESCRIPTION	PART NO. (MJI)
X011	SR-39	4822 242 82242	FILTER CERAMIC BFU450C4N	*FF100190R
X012		4822 242 72333	CRYSTAL 7.2MHz	JX07001261
X013		4822 242 11042	CRYSTAL 4.332MHz	*JX000540R
INPUT CIRCUIT BOARD				
CAPACITORS				
C101		nsp	CER. 18pF 50V J	nsp
C102		nsp	CER. 18pF 50V J	nsp
C103		nsp	CER. 180pF 50V K	nsp
C104		nsp	CER. 180pF 50V K	nsp
C105		nsp	CER. 100pF 50V K	nsp
C106		nsp	CER. 100pF 50V K	nsp
C107		nsp	ELECT 4.7μF 50V	nsp
C108		nsp	ELECT 4.7μF 50V	nsp
C109		nsp	CER. 1000pF 50V K	nsp
C110		nsp	CER. 1000pF 50V K	nsp
C111		nsp	ELECT 47μF 25V	nsp
C112		nsp	ELECT 47μF 25V	nsp
C113		nsp	MYLAR 5600pF 50V J	nsp
C114		nsp	MYLAR 5600pF 50V J	nsp
C115		nsp	MYLAR 0.022μF 50V J	nsp
C116		nsp	MYLAR 0.022μF 50V J	nsp
C117		nsp	ELECT 47μF 25V	nsp
C118		nsp	ELECT 47μF 25V	nsp
C123		nsp	ELECT 4.7μF 50V	nsp
}				
C126		nsp	ELECT 4.7μF 50V	nsp
C127		nsp	ELECT 4.7μF 50V	nsp
}	SR-39	nsp	CER. 100pF 50V K	nsp
C134		nsp	CER. 100pF 50V K	nsp
C143		nsp	CER. 100pF 50V K	nsp
}	SR-39	nsp	CER. 100pF 50V K	nsp
C150		nsp	ELECT 100μF 16V	nsp
C155		nsp	ELECT 100μF 16V	nsp
C156		nsp	ELECT 47μF 16V	nsp
C157		nsp	ELECT 47μF 16V	nsp
C159		nsp	ELECT 47μF 25V	nsp
C160		nsp	ELECT 47μF 25V	nsp
C161		nsp	MYLAR 0.1μF 50V J	nsp
C162		nsp	MYLAR 0.1μF 50V J	nsp
C163		nsp	ELECT 330μF 10V	nsp
DIODE				
D101		4822 130 30621	1N4148	QP13030621
D102				
}		4822 130 31878	1N4003	HD200010AR
D105				
INTEGRATED CIRCUIT				
IC11		4822 209 73064	NJM2068DD	HC10053090
IC12		4822 209 73064	NJM2068DD	HC10053090
IC13		4822 209 32552	LC78211	HC10308030
RESISTOR				
R101		nsp	470 Ω 1/5W J	nsp
R102		nsp	470 Ω 1/5W J	nsp
R103		nsp	390 Ω 1/5W J	nsp
R104		nsp	390 Ω 1/5W J	nsp
R105		nsp	47k Ω 1/5W J	nsp
R106		nsp	47k Ω 1/5W J	nsp
R107		nsp	200 Ω 1/5W J	nsp
R108		nsp	200 Ω 1/5W J	nsp
R109		nsp	12k Ω 1/5W J	nsp
R110		nsp	12k Ω 1/5W J	nsp
R111		nsp	180k Ω 1/5W J	nsp
R112		nsp	180k Ω 1/5W J	nsp
R113		nsp	220k Ω 1/5W J	nsp
R114		nsp	220k Ω 1/5W J	nsp

POS. NO	VERS. COLOR	PART NO. (FOR PCS)	DESCRIPTION	PART NO. (MJI)
R115		nsp	120 Ω 1/4W J	nsp
}				
R118		nsp	47k Ω 1/5W J	nsp
R119		nsp	47k Ω 1/5W J	nsp
R120		nsp	47k Ω 1/5W J	nsp
R121		nsp	470 Ω 1/5W J	nsp
}				
R124		nsp	47k Ω 1/5W J	nsp
R125		nsp	47k Ω 1/5W J	nsp
R126		nsp	47k Ω 1/5W J	nsp
R127		nsp	470 Ω 1/5W J	nsp
}				
R130		nsp	470 Ω 1/5W J	nsp
R135		nsp	470 Ω 1/5W J	nsp
}				
R138		nsp	1k Ω 1/5W J	nsp
R139		nsp	1k Ω 1/5W J	nsp
R140		nsp	1k Ω 1/5W J	nsp
R141		nsp	1k Ω 1/5W J	nsp
R142		nsp	120 Ω 1/4W J	nsp
R143		nsp	120 Ω 1/4W J	nsp
R144		nsp	10k Ω 1/5W J	nsp
MISCELLANEOUS				
JK11		4822 265 11651	JACK 2P VERTICL	*YT001650R
JK12		4822 265 11652	JACK IN/OUT JK0400450N	*YT001660R
JK13		4822 265 11652	JACK IN/OUT JK0400450N	*YT001660R
POWER AMP CIRCUIT BOARD				
CAPACITOR				
C501		nsp	ELECT 4.7μF 50V	nsp
C502		nsp	ELECT 4.7μF 50V	nsp
C503		nsp	CER. 100pF 50V K	nsp
C504		nsp	CER. 100pF 50V K	nsp
C507		nsp	ELECT 47μF 16V	nsp
C508		nsp	ELECT 47μF 16V	nsp
C509		nsp	CER. 1pF 50V C	nsp
C510		nsp	CER. 1pF 50V C	nsp
C511		nsp	CER. 180pF 50V K	nsp
C512		nsp	CER. 180pF 50V K	nsp
C513		nsp	MYLAR 0.022μF 50V J	nsp
}				
C516		nsp	MYLAR 0.022μF 50V J	nsp
▲ C517	SR-39	nsp	ELECT 470μF 50V	nsp
▲ C517	SR-48	nsp	ELECT 470μF 50V	nsp
▲ C517	SR-68	nsp	ELECT 470μF 63V	nsp
▲ C518	SR-39	nsp	ELECT 470μF 50V	nsp
▲ C518	SR-48	nsp	ELECT 470μF 50V	nsp
▲ C518	SR-68	nsp	ELECT 470μF 63V	nsp
▲ C519	SR-39	nsp	ELECT 470μF 50V	nsp
▲ C519	SR-48	nsp	ELECT 470μF 50V	nsp
▲ C519	SR-68	nsp	ELECT 470μF 63V	nsp
▲ C520	SR-39	nsp	ELECT 470μF 50V	nsp
▲ C520	SR-48	nsp	ELECT 470μF 50V	nsp
▲ C520	SR-68	nsp	ELECT 470μF 63V	nsp
C521		nsp	ELECT 10μF 50V	nsp
C522		nsp	ELECT 10μF 50V	nsp
C523		nsp	ELECT 470μF 10V	nsp
C524		nsp	ELECT 47μF 25V	nsp
DIODE				
D501		4822 130 30621	1N4148	QP13030621
D502		4822 130 30621	1N4148	QP13030621
D503		4822 130 30621	1N4148	QP13030621
D505	SR-68	4822 130 30621	1N4148	QP13030621
COIL				
L501		4822 157 11872	COIL 0.5H	*LC107210R
L502		4822 157 11872	COIL 0.5H	*LC107210R

(VERS.:VERSION, U:U.S.A., F:JAPAN, K:FAR EAST, **:EUROPE)

(VERS.:VERSION, U:U.S.A., F:JAPAN, K:FAR EAST, **:EUROPE)

POS. NO	VERS. COLOR	PART NO. (FOR PCS)	DESCRIPTION	PART NO. (MJI)
			TRANSISTOR	
Q501		4822 130 11615	KTA1268GR	*HT100400R
Q508				
Q509		4822 130 11616	KTC3200GR	*HT300610R
Q510		4822 130 11616	KTC3200GR	*HT300610R
Q511		4822 130 11615	KTA1268GR	*HT100400R
Q512		4822 130 11615	KTA1268GR	*HT100400R
Q513		4822 130 11616	KTC3200GR	*HT300610R
Q514		4822 130 11616	KTC3200GR	*HT300610R
Q515	SR-39	4822 130 11682	KSA910Y	*HT100450R
Q515	SR-48	4822 130 11682	KSA910Y	*HT100450R
Q515	SR-68	nsp	2SA1360O	*HT100410R
Q516	SR-39	4822 130 11682	KSA910Y	*HT100450R
Q516	SR-48	4822 130 11682	KSA910Y	*HT100450R
Q516	SR-68	nsp	2SA1360O	*HT100410R
Q517	SR-39	5322 130 63836	KSC2310Y	*HT300670R
Q517	SR-48	5322 130 63836	KSC2310Y	*HT300670R
Q517	SR-68	nsp	2SC3423O	*HT300620R
Q518	SR-39	5322 130 63836	KSC2310Y	*HT300670R
Q518	SR-48	5322 130 63836	KSC2310Y	*HT300670R
Q518	SR-68	nsp	2SC3423O	*HT300620R
Q519	SR-39	4822 130 11617	KSC2316Y	*HT300580R
Q519	SR-48	4822 130 11617	KSC2316Y	*HT300580R
Q519	SR-68	nsp	2SD1763AE	*HT400390R
Q520	SR-39	4822 130 11617	KSC2316Y	*HT300580R
Q520	SR-48	4822 130 11617	KSC2316Y	*HT300580R
Q520	SR-68	nsp	2SD1763AE	*HT400390R
Q521	SR-39	4822 130 11683	KSA916Y	*HT100460R
Q521	SR-48	4822 130 11683	KSA916Y	*HT100460R
Q521	SR-68	nsp	2SB1186AE	*HT200350R
Q522	SR-39	4822 130 11683	KSA916Y	*HT100460R
Q522	SR-48	4822 130 11683	KSA916Y	*HT100460R
Q522	SR-68	nsp	2SB1186AE	*HT200350R
Q523		4822 130 63899	2SC4137V	*HT300660R
Q524		4822 130 63899	2SC4137V	*HT300660R
Q525	SR-39	4822 130 63429	2SC4466 POWER	HT344663A0
Q525	SR-48	nsp	2SC4467 POWER	HT344673A0
Q525	SR-68	nsp	2SC4468 POWER	HT344683A0
Q526	SR-39	4822 130 63429	2SC4466 POWER	HT344663A0
Q526	SR-48	nsp	2SC4467 POWER	HT344673A0
Q526	SR-68	nsp	2SC4468 POWER	HT344683A0
Q527	SR-39	4822 130 63428	2SA1693 POWER	HT116933A0
Q527	SR-48	nsp	2SA1694 POWER	HT116943A0
Q527	SR-68	nsp	2SA1695 POWER	HT116953A0
Q528	SR-39	4822 130 63428	2SA1693 POWER	HT116933A0
Q528	SR-48	nsp	2SA1694 POWER	HT116943A0
Q528	SR-68	nsp	2SA1695 POWER	HT116953A0
Q529		4822 130 42431	2SC1740SR	*HT300630R
Q530		4822 130 42431	2SC1740SR	*HT300630R
Q531		4822 130 63385	DTA114YS	*HT300480R
Q532		4822 130 42431	2SC1740SR	*HT300630R
Q533		4822 130 42431	2SC1740SR	*HT300630R
Q534		4822 130 42431	2SC1740SR	*HT300630R
Q535		4822 130 42715	2SA933SR	HT10001000
			RESISTOR	
R501		nsp	1k Ω 1/5W J	nsp
R502		nsp	1k Ω 1/5W J	nsp
R503		nsp	27k Ω 1/5W J	nsp
R504		nsp	27k Ω 1/5W J	nsp
R505		nsp	47k Ω 1/5W J	nsp
R506		nsp	47k Ω 1/5W J	nsp
R507		nsp	220 Ω 1/5W J	nsp
R508		nsp	220 Ω 1/5W J	nsp
R509	SR-39	nsp	10k Ω 1/5W J	nsp
R509	SR-48	nsp	10k Ω 1/5W J	nsp
R509	SR-68	nsp	18k Ω 1/5W J	nsp

POS. NO	VERS. COLOR	PART NO. (FOR PCS)	DESCRIPTION	PART NO. (MJI)
R510	SR-39	nsp	10k Ω 1/5W J	nsp
R510	SR-48	nsp	10k Ω 1/5W J	nsp
R510	SR-68	nsp	18k Ω 1/5W J	nsp
R511				
		nsp	180 Ω 1/5W J	nsp
R514				
R517		nsp	1.5k Ω 1/5W J	nsp
R520				
R521		nsp	33k Ω 1/5W J	nsp
R522		nsp	33k Ω 1/5W J	nsp
R523	SR-39	nsp	2.2k Ω 1/5W J	nsp
R523	SR-48	nsp	1.8k Ω 1/5W J	nsp
R523	SR-68	nsp	1.5k Ω 1/5W J	nsp
R524	SR-39	nsp	2.2k Ω 1/5W J	nsp
R524	SR-48	nsp	1.8k Ω 1/5W J	nsp
R524	SR-68	nsp	1.5k Ω 1/5W J	nsp
R525				
		nsp	560 Ω 1/5W J	nsp
R530				
R531		nsp	4.7k Ω 1/5W J	nsp
R534				
R535		nsp	560 Ω 1/5W J	nsp
R538				
R539		nsp	22k Ω 1/5W J	nsp
R542				
R543		nsp	1.2k Ω 1/5W J	nsp
R544		nsp	1.2k Ω 1/5W J	nsp
R545		nsp	470 Ω 1/5W J	nsp
R546		nsp	470 Ω 1/5W J	nsp
R547				
		nsp	120 Ω 1/5W J	nsp
R550				
R551		nsp	75 Ω 1/5W J	nsp
R552		nsp	75 Ω 1/5W J	nsp
R553		nsp	75 Ω 1/5W J	nsp
R554		nsp	75 Ω 1/5W J	nsp
R555		nsp	82 Ω 1/5W J	nsp
R556		nsp	82 Ω 1/5W J	nsp
R557				
		nsp	10 Ω 1/4W J	nsp
R560				
R561		4822 117 13654	CEMENT (X2) 0.22 Ω 5W X2	*GO000006R
R562		4822 117 13654	CEMENT (X2) 0.22 Ω 5W X2	*GO000006R
R567		nsp	910 Ω 1/5W J	nsp
R568		nsp	910 Ω 1/5W J	nsp
R569		nsp	1.8k Ω 1/5W J	nsp
R570		nsp	1.8k Ω 1/5W J	nsp
R571		nsp	10k Ω 1/5W J	nsp
R572		nsp	10k Ω 1/5W J	nsp
R573		nsp	27k Ω 1/5W J	nsp
R574		nsp	27k Ω 1/5W J	nsp
R575		nsp	100 Ω 1/5W J	nsp
R576		nsp	1.5k Ω 1/5W J	nsp
R578		nsp	82 Ω 1/5W J	nsp
R579		nsp	1.5k Ω 1/5W J	nsp
R580	SR-68	nsp	1.5k Ω 1/5W J	nsp
R581		nsp	22k Ω 1/5W J	nsp
R582		nsp	22k Ω 1/5W J	nsp
R583		nsp	1.8k Ω 1/5W J	nsp
R584		nsp	1.8k Ω 1/5W J	nsp
R585		nsp	47k Ω 1/5W J	nsp
R586		nsp	1k Ω 1/5W J	nsp

(VERS.:VERSION, U:U.S.A., F:JAPAN, K:FAR EAST, **:EUROPE)

POS. NO	VERS. COLOR	PART NO. (FOR PCS)	DESCRIPTION	PART NO. (MJI)
			MISCELLANEOUS	
RY51	SR-39	4822 280 10386	RELAY OSA-SS-212DM3	*LY000180R
RY51	SR-48	4822 280 10386	RELAY OSA-SS-212DM3	*LY000180R
RY51	SR-68	nsp	RELAY OSA-SS-212DM5	*LY000210R
TH51		4822 117 13675	POSISTOR PTH9M04BC471TS	*HP000050R
			POWER SUPPLY CIRCUIT BOARD CAPACITOR	
C291				
}	SR-39	nsp	CER. 100pF 50V K	nsp
C294				
C605				
}	SR-39	nsp	CER. 0.0022μF 50V	nsp
C608				
▲ C901	SR-39	4822 124 12445	ELECT 4700μF 50V	*EA000900R
▲ C901	SR-48	nsp	ELECT 6800μF 50V	*EA000910R
▲ C901	SR-68	nsp	ELECT 8200μF 63V	*EA000890R
▲ C902	SR-39	4822 124 12445	ELECT 4700μF 50V	*EA000900R
▲ C902	SR-48	nsp	ELECT 6800μF 50V	*EA000910R
▲ C902	SR-68	nsp	ELECT 8200μF 63V	*EA000890R
C903				
}		nsp	MYLAR 0.047μF 50V J	nsp
C907				
C908		nsp	CER. 0.022μF 50V	nsp
C909		nsp	CER. 0.022μF 50V	nsp
▲ C910		4822 124 12414	ELECT 2200μF 35V	*EA000850R
▲ C911		nsp	ELECT 100μF 35V	nsp
▲ C913		nsp	ELECT 100μF 35V	nsp
C914		nsp	CER. 0.022μF 50V	nsp
▲ C915		nsp	ELECT 100μF 35V	nsp
▲ C916		nsp	ELECT 100μF 35V	nsp
C917		nsp	CER. 0.022μF 50V	nsp
C918		nsp	ELECT 33μF 50V	nsp
C919		nsp	CER. 0.022μF 50V	nsp
C920		nsp	CER. 680pF 50V K	nsp
C921		nsp	CER. 680pF 50V K	nsp
C922		nsp	CER. 0.022μF 50V	nsp
C923		nsp	ELECT 4.7μF 50V	nsp
▲ C924		nsp	ELECT 100μF 35V	nsp
C925		nsp	ELECT 4.7μF 50V	nsp
C926		nsp	CER. 0.022μF 50V	nsp
▲ C928		nsp	ELECT 470μF 25V	nsp
C929		nsp	ELECT 4.7μF 50V	nsp
C930		nsp	CER. 0.022μF 50V	nsp
C931		nsp	CER. 0.022μF 50V	nsp
C932				
}		nsp	CER. 100pF 50V K	nsp
C935				
C937	SR-39	nsp	CER.0.0022μF 50V	nsp
C938	SR-39	nsp	CER. 0.0022μF 50V	nsp
C939		nsp	CER. 0.022μF 50V	nsp
C940		nsp	MYLAR 1500pF 50V J	nsp
C941		nsp	MYLAR 1500pF 50V J	nsp
▲ C936		nsp	ELECT 470μF 25V	nsp
			DIODE	
▲ D901	SR-39	4822 130 11684	BRIDGE KBJ404G	*HE200210R
▲ D901	SR-48	4822 130 11684	BRIDGE KBJ404G	*HE200210R
▲ D901	SR-68	nsp	BRIDGE KBJ604G	*HE200220R
▲ D902		4822 130 31878	1N4003	HD200010AR
}				
▲ D905		4822 130 11685	ZENER 16V 1/2W	*HD301660R
▲ D907		4822 130 31878	1N4003	HD200010AR
▲ D908		4822 130 31878	1N4003	HD200010AR
▲ D909		4822 130 31878	1N4003	HD200010AR

(VERS.:VERSION, U:U.S.A., F:JAPAN, K:FAR EAST, **:EUROPE)

POS. NO	VERS. COLOR	PART NO. (FOR PCS)	DESCRIPTION	PART NO. (MJI)
▲ D910		4822 130 10624	ZENER 27V 1/2W	*HD301610R
▲ D911		4822 130 11132	ZENER 6.2V 1/2W	*HD301450R
▲ D912				
}		4822 130 31878	1N4003	HD200010AR
▲ D915				
			INTEGRATED CIRCUIT	
▲ IC91		4822 209 90746	MC7806	*HC300240R
▲ IC92		5322 209 71759	MC7815	*HC300220R
			TRANSISTOR	
Q491		4822 130 63904	KTD1302	*HT400400R
Q492		4822 130 63904	KTD1302	*HT400400R
Q902		4822 130 11683	KSA916Y	*HT100460R
▲ Q903		4822 130 11621	KTA1271Y	*BA000760R
Q904		4822 130 62503	DTC114YS	*BA000730R
			RESISTOR	
R291		nsp	470 Ω 1/5W J	nsp
R292		nsp	470 Ω 1/5W J	nsp
R293		nsp	2.2k Ω 1/5W J	nsp
R294		nsp	2.2k Ω 1/5W J	nsp
R295		nsp	1k Ω 1/5W J	nsp
R296		nsp	1k Ω 1/5W J	nsp
R901		nsp	15k Ω 1/5W J	nsp
R902		nsp	15k Ω 1/5W J	nsp
R903		nsp	1 Ω 1/5W J	nsp
R904		nsp	2.2k Ω 1/5W J	nsp
R905		nsp	10k Ω 1/5W J	nsp
R906		nsp	2.2k Ω 1/5W J	nsp
R907		nsp	68 Ω 1/5W J	nsp
R909		nsp	10 Ω 1/5W J	nsp
▲ R910	SR-48	nsp	3.3M Ω	nsp
▲ R910	SR-68	nsp	3.3M Ω	nsp
R911		nsp	39k Ω 1/4W J	nsp
R912		nsp	39k Ω 1/4W J	nsp
R913		nsp	39k Ω 1/4W J	nsp
R914		nsp	39k Ω 1/4W J	nsp
R915		nsp	10 Ω 1/4W J	nsp
R916		nsp	10k Ω 1/5W J	nsp
R917		nsp	10k Ω 1/5W J	nsp
R918		nsp	1k Ω 1/5W J	nsp
R919		nsp	10 Ω 1/4W J	nsp
▲ RY91		4822 280 10387	RELAY HR-CR7-DC12V	*LY000190R
			SWITCH	
S901		4822 276 14107	TACT SW	*SP000880R
			FUSE	
▲ F901	SR-39	4822 070 11602	1.6A 250V(EUR)	*FS000530R
▲ F901	SR-48	nsp	4A 250V(UL)	*FS000650R
▲ F901	SR-68	nsp	5A 250V(UL)	*FS000660R
▲ F903	SR-39	4822 070 11002	1A 250V(EUR)	*FS000550R
▲ F903	SR-48	nsp	1.25A 250V(UL)	*FS000640R
▲ F903	SR-68	nsp	1.25A 250V(UL)	*FS000640R
▲ F904	SR-39	4822 070 11002	1A 250V(EUR)	*FS000550R
▲ F904	SR-48	nsp	1.25A 250V(UL)	*FS000640R
▲ F904	SR-68	nsp	1.25A 250V(UL)	*FS000640R
			MISCELLANEOUS	
JK92		4822 265 11653	JACK BOARD ORANGE 2P VERTI	*YT001640R
JK93	SR-39	4822 265 11654	TERMINAL SPEAKER 8P	*YT001670R
JK93	SR-48	nsp	SPEAKER TERMINAL 8P	*YT001480R
JK93	SR-68	nsp	SPEAKER TERMINAL 8P	*YT001480R

(VERS. :VERSION, U:U.S.A., F:JAPAN, K:FAR EAST, **:EUROPE)

(VERS. :VERSION, U:U.S.A., F:JAPAN, K:FAR EAST, **:EUROPE)

POS. NO	VERS. COLOR	PART NO. (FOR PCS)	DESCRIPTION	PART NO. (MJI)
▲ OL91	SR-39	4822 265 11604	AC OUTLET (1P)	*YT001490R
▲ OL91	SR-48	nsp	AC OUTLET (1P)	*YT001620R
▲ OL91	SR-48	nsp	AC OUTLET (1P)	*YT001620R
▲ T901	SR-39	4822 146 11197	TRANS SUB 220V	*TS000980R
▲ T901	SR-68	nsp	TRANS SUB 120V	*TS000990R
	SR-48			
▲ T902	SR-39	4822 146 11198	TRANS MAIN SR-39 (220V 74x42)	*TS001010R
▲ T902	SR-48	nsp	TRANS MAIN SR-48 (120V 74x60)	*TS001000R
▲ T902	SR-68	nsp	TRANS MAIN SR-68 (120V 86x50)	*TS001020R

POS. NO	VERS. COLOR	PART NO. (FOR PCS)	DESCRIPTION	PART NO. (MJI)
---------	-------------	--------------------	-------------	----------------