

Service Manual

74 SR50/60B/65B

Audio/Video stereo receiver

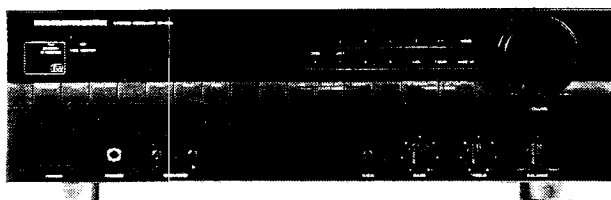

TABLE OF CONTENTS

SECTION	PAGE
1. BLOCK DIAGRAM	1
2. SCHEMATIC DIAGRAM AND PARTS LOCATION (Pattern side)	3
3. EXPLODED VIEW AND PARTS LIST	17
4. TEST EQUIPMENT REQUIRED FOR SERVICING	18
5. IDLING CURRENT ADJUSTMENT	19
6. VOLTAGE CONVERSION	19
7. HOW TO CHANGE THE SUPPLY VOLTAGE	19
8. SERVICE PROGRAM	20
9. TUNER ALIGMENT PROCEDURS	20
10. ALIGMENT AND TEST POINT	23
11. TUNER MICROPROCESSOR SPECIFICATIONS	23
12. ELECTRICAL PARTS LIST	26

marantz®

model SR-50L

First issue: 1990

4822 725 50917

TECHNICAL SPECIFICATIONS (DIN)

FM TUNER SECTION

Frequency range	87.5 – 108 MHz
Sensitivity DIN (Mono/Stereo)	1.0/25 μ V
S/N (Mono/Stereo)	76/68 dB
T.H.D.	0.2/0.4%
Selectivity at 98 MHz (\pm 300 kHz)	60 dB

MW TUNER SECTION

Frequency range	531 – 1602 kHz
Sensitivity (S/N 20 dB 30% 1 MHz)	500 μ V
S/N at 1 MHz	50 dB

LW TUNER SECTION

Frequency range	152 – 282 kHz
Sensitivity (S/N 20 dB 30% 1 MHz)	1000 μ V

AMPLIFIER SECTION

Power output	DIN 8 Ω	50W
	RMS 8 Ω	40W
T.H.D. at 8 Ω rated RMS output		0.09%
Damping factor		50
Input sensitivity	: PHONO	3.5 mV/47 k Ω
	: CD/TV/CDV/VCR/TAPE	220 mV/47 k Ω
S/N (IHF-A)	: PHONO	76 dB
	: CD/TV/CDV/VCR/TAPE	86 dB

POWER SUPPLY AC 220V, 50/60 Hz

DIMENSIONS

Width	420 mm
Height	118 mm
Depth	334 mm

WEIGHT 6.5 kg

SUPPLIED ACCESSORIES

- Remote controller (RC-60SR) x 1
- Batteries (Size "AAA", R03) x 2
- FM dipole antenna x 1
- AM loop antenna x 1

Specifications subject to change without prior notice.

1. BLOCK DIAGRAM

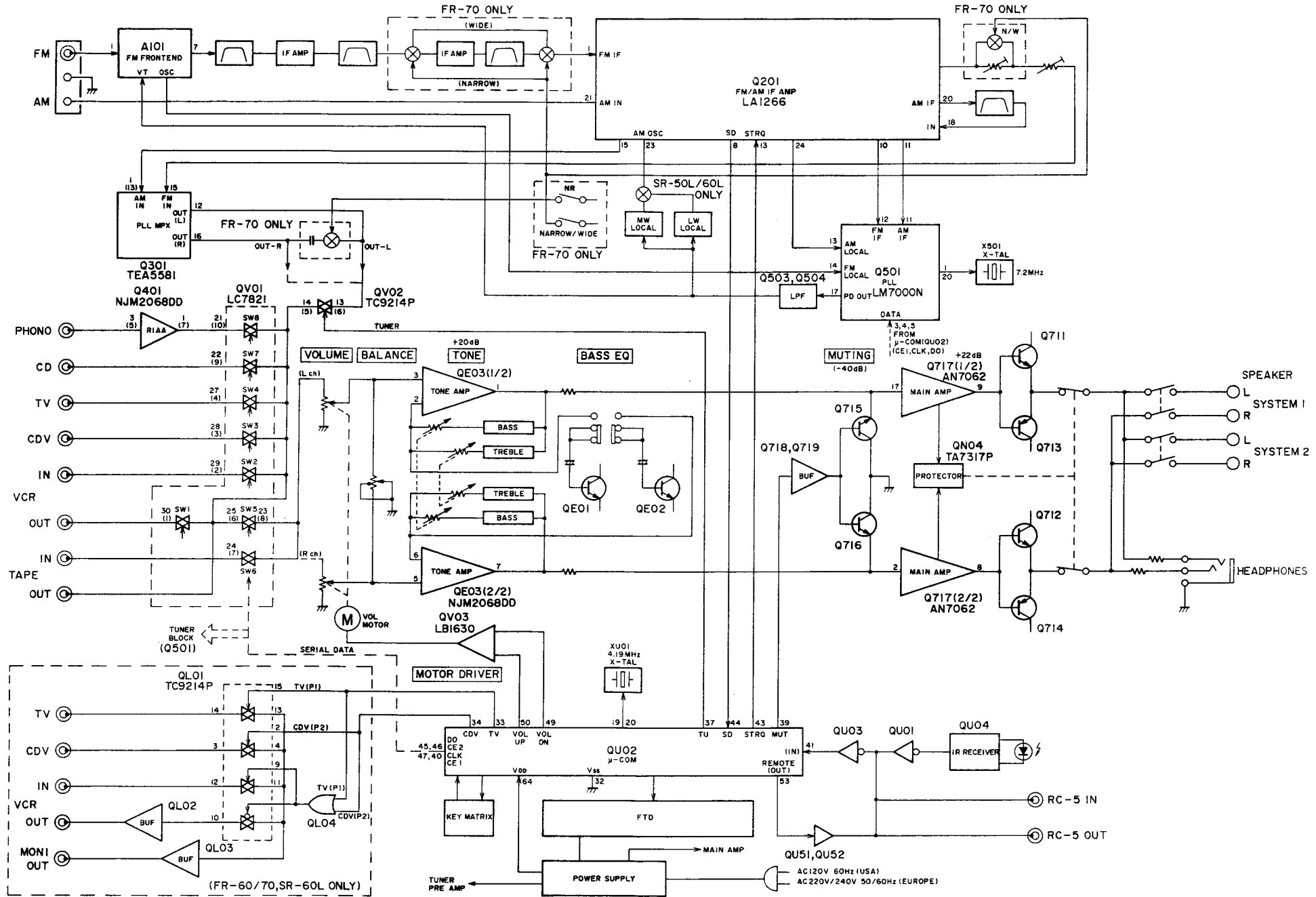

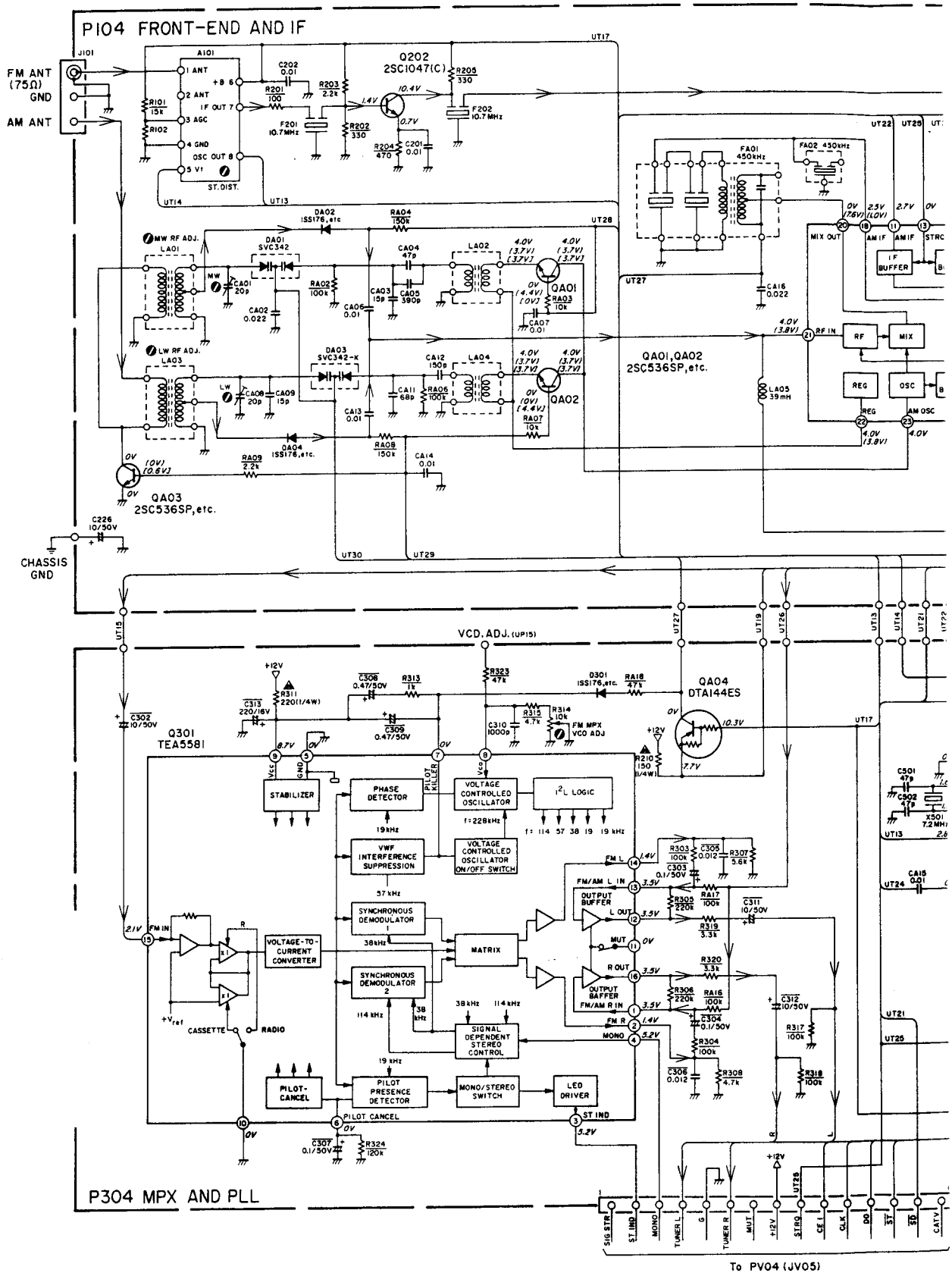

FRONT-END AND IF

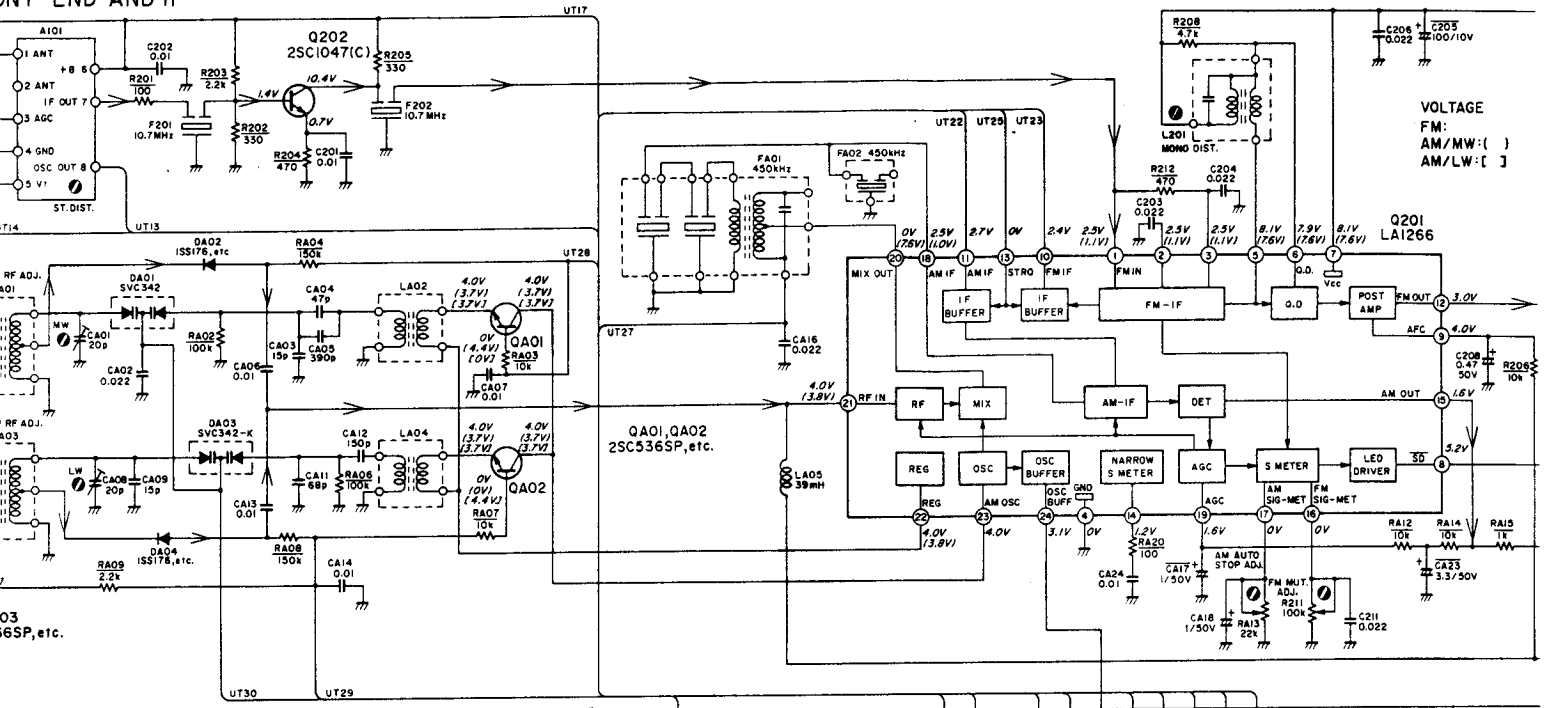

FM AND PLL

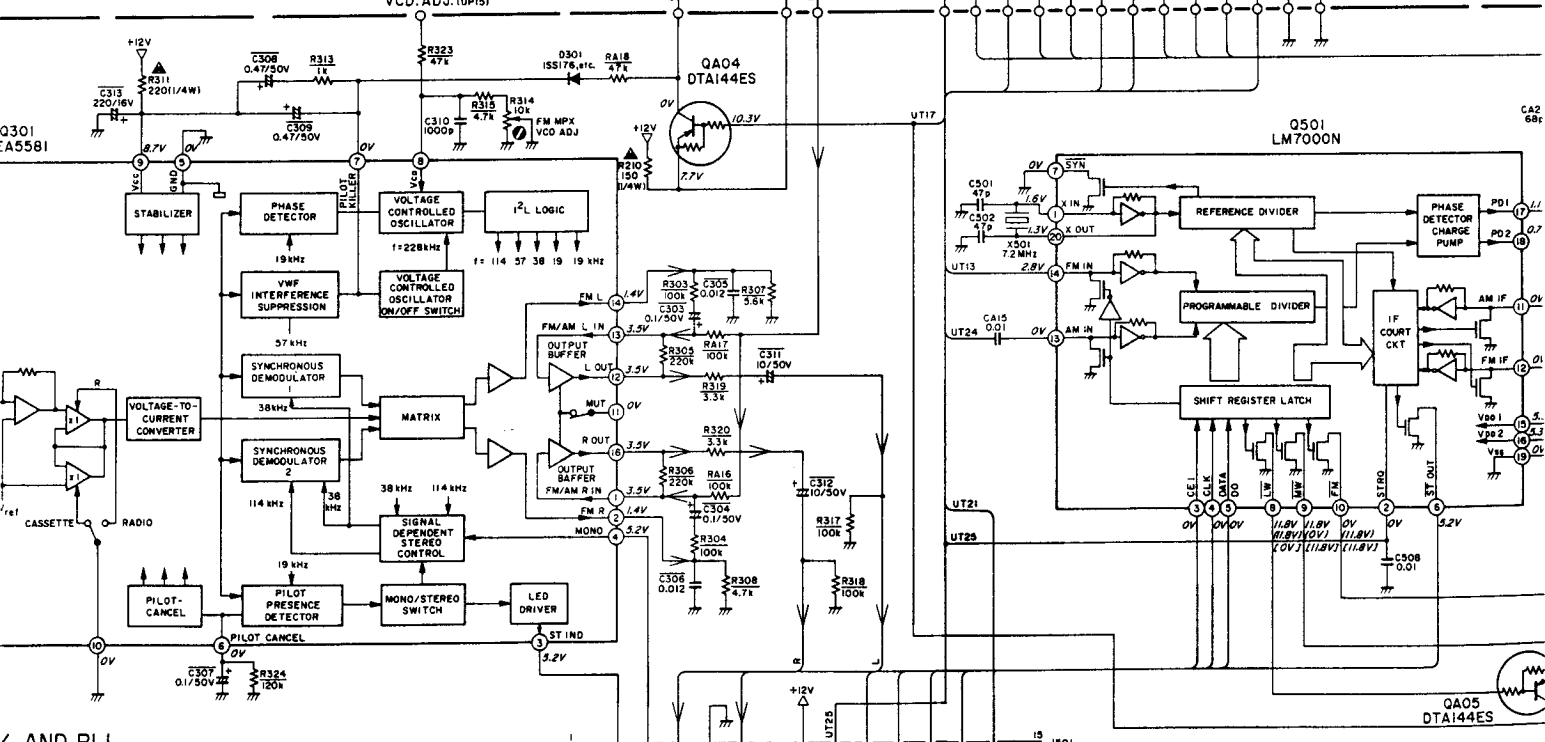

VOLTAGE
 FM: ()
 AM/MW: ()
 AM/LW: ()

NOTE ON SAFETY:
 Symbol ▲ Fire or elec
 be used to replace any i
 ponent substitution (ot)
 or electrical shock hazar

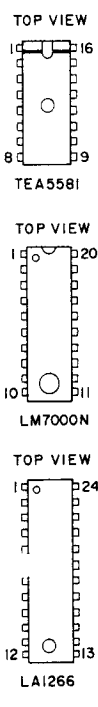
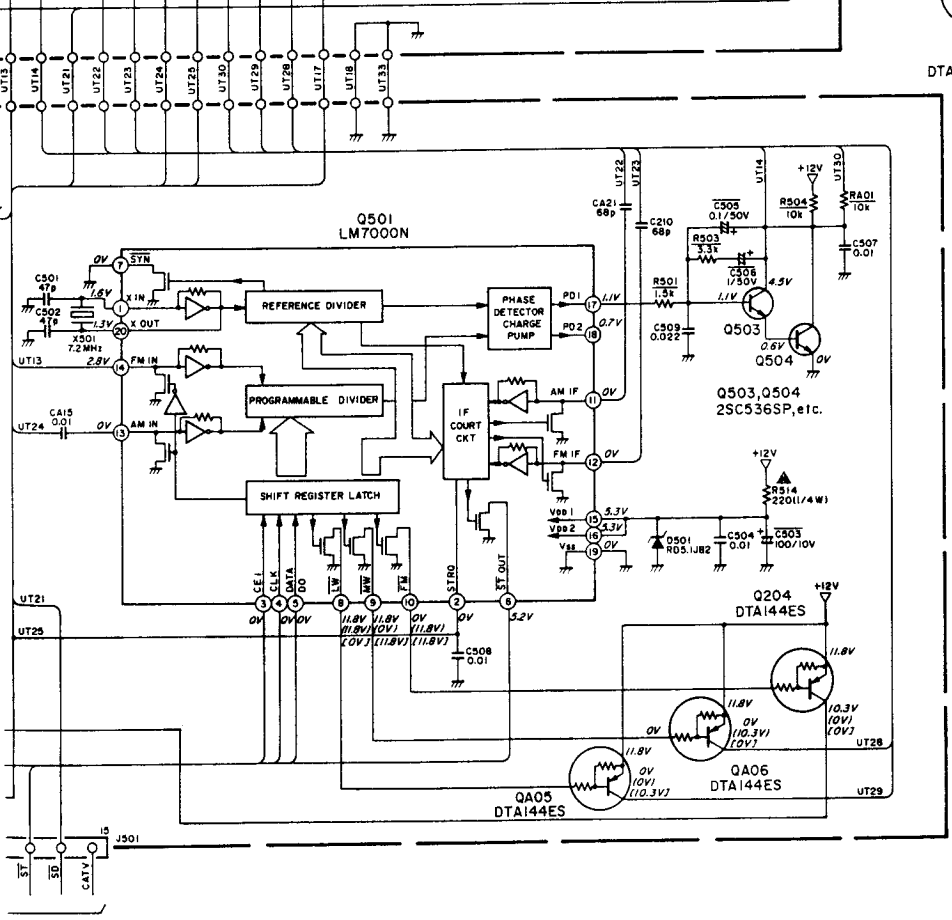
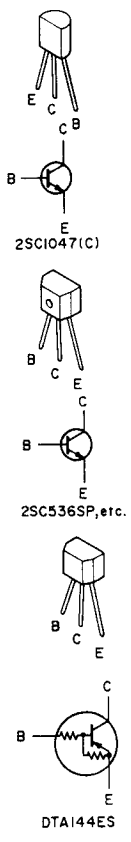
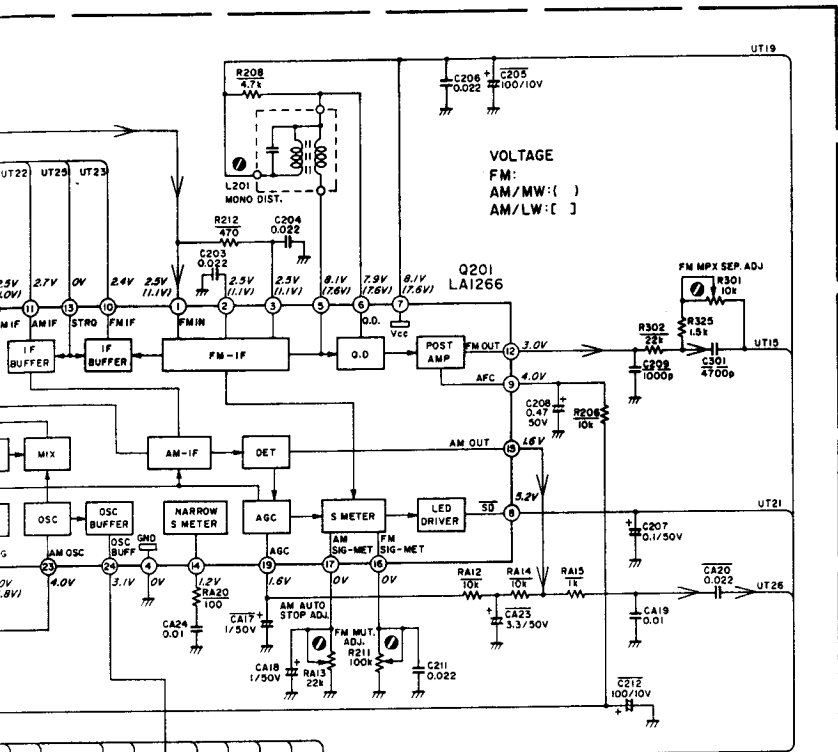

NOTE ON SAFETY:
 Symbol ▲ Fire or electrical shock hazard. Only original parts should be used to replace any part marked with symbol ▲. Any other component substitution (other than original type), may increase risk of fire or electrical shock hazard.

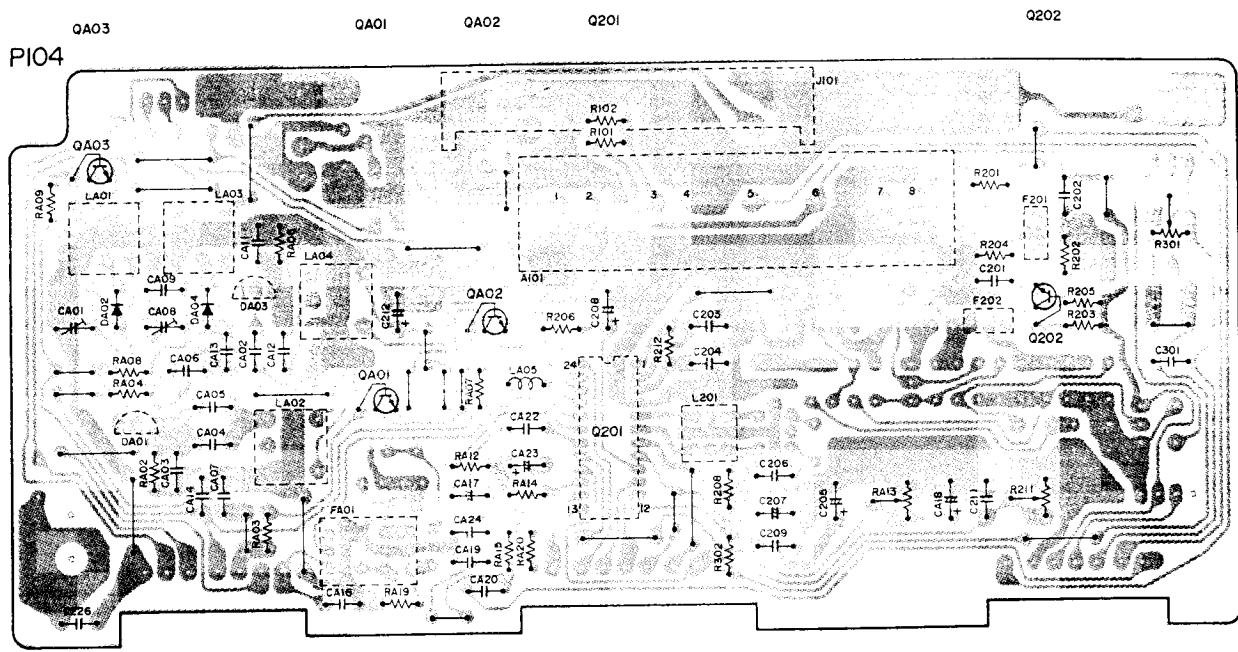

N
T

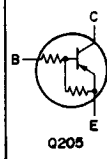
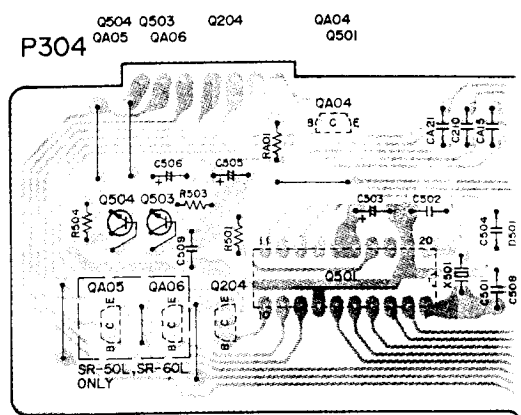
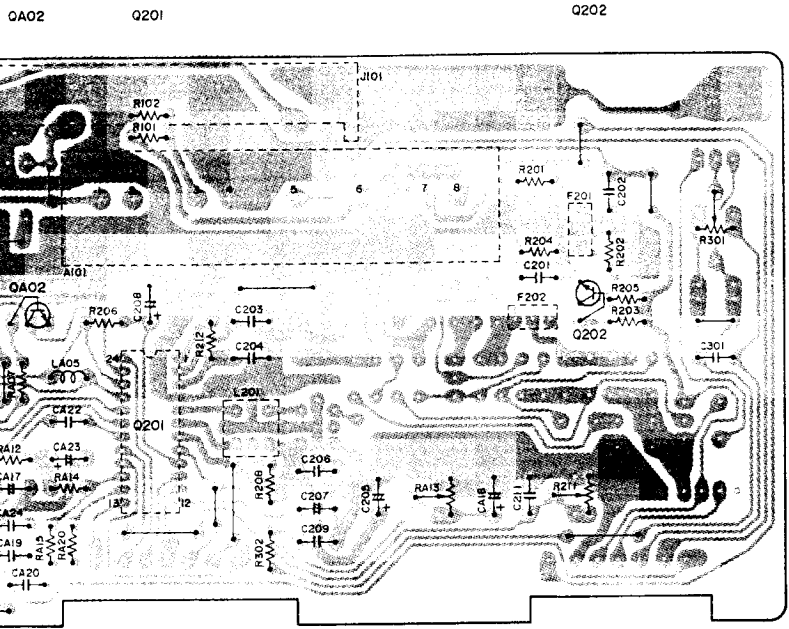

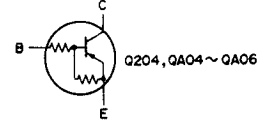
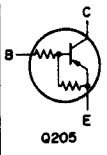
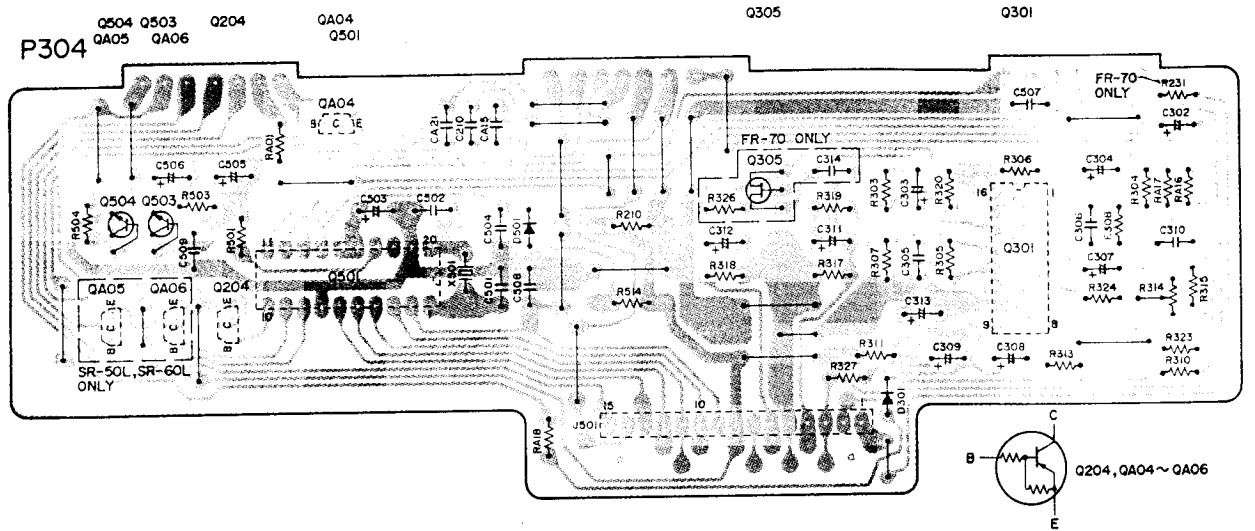

PUO4 μ -COM, TACT SW. AND FL.

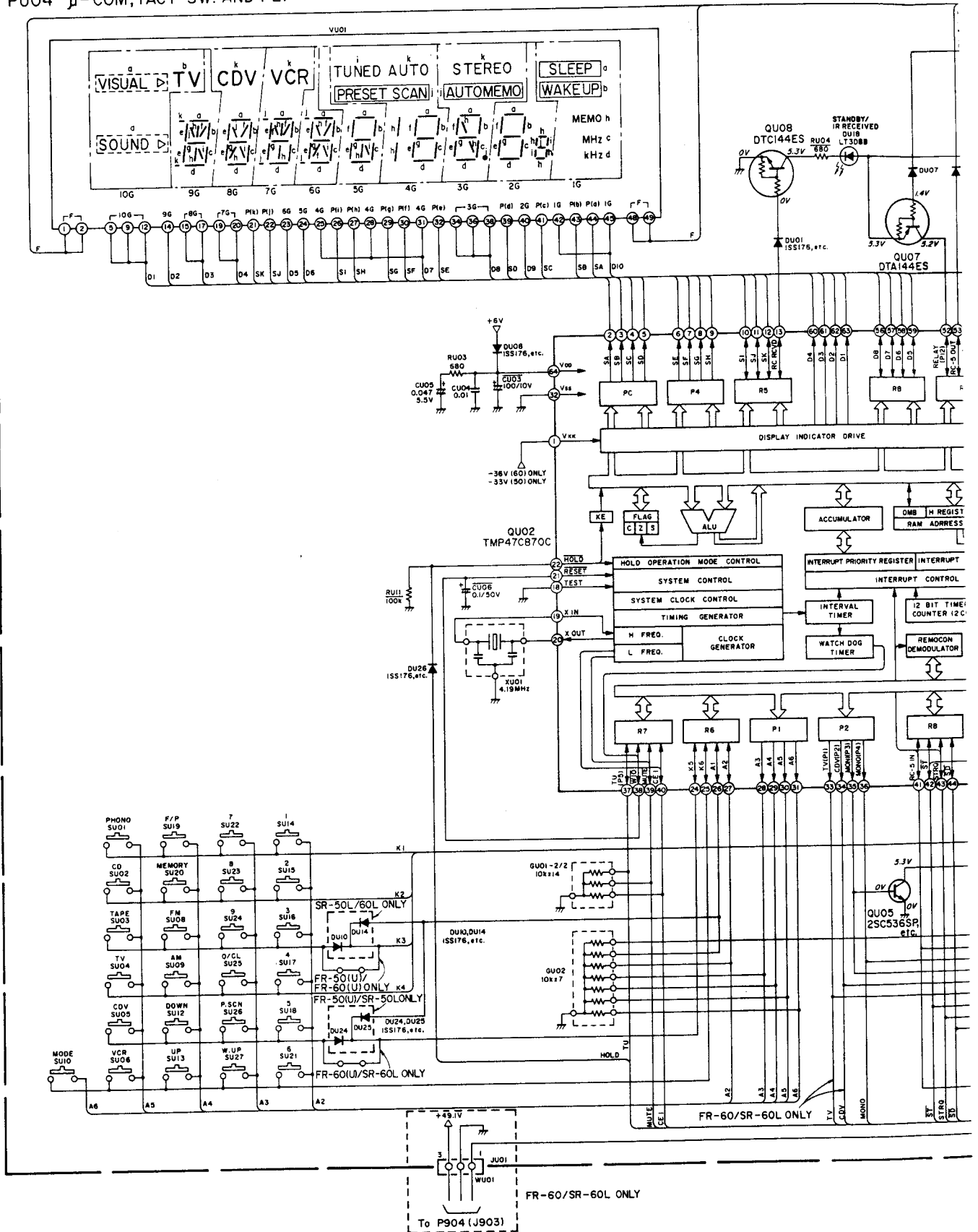

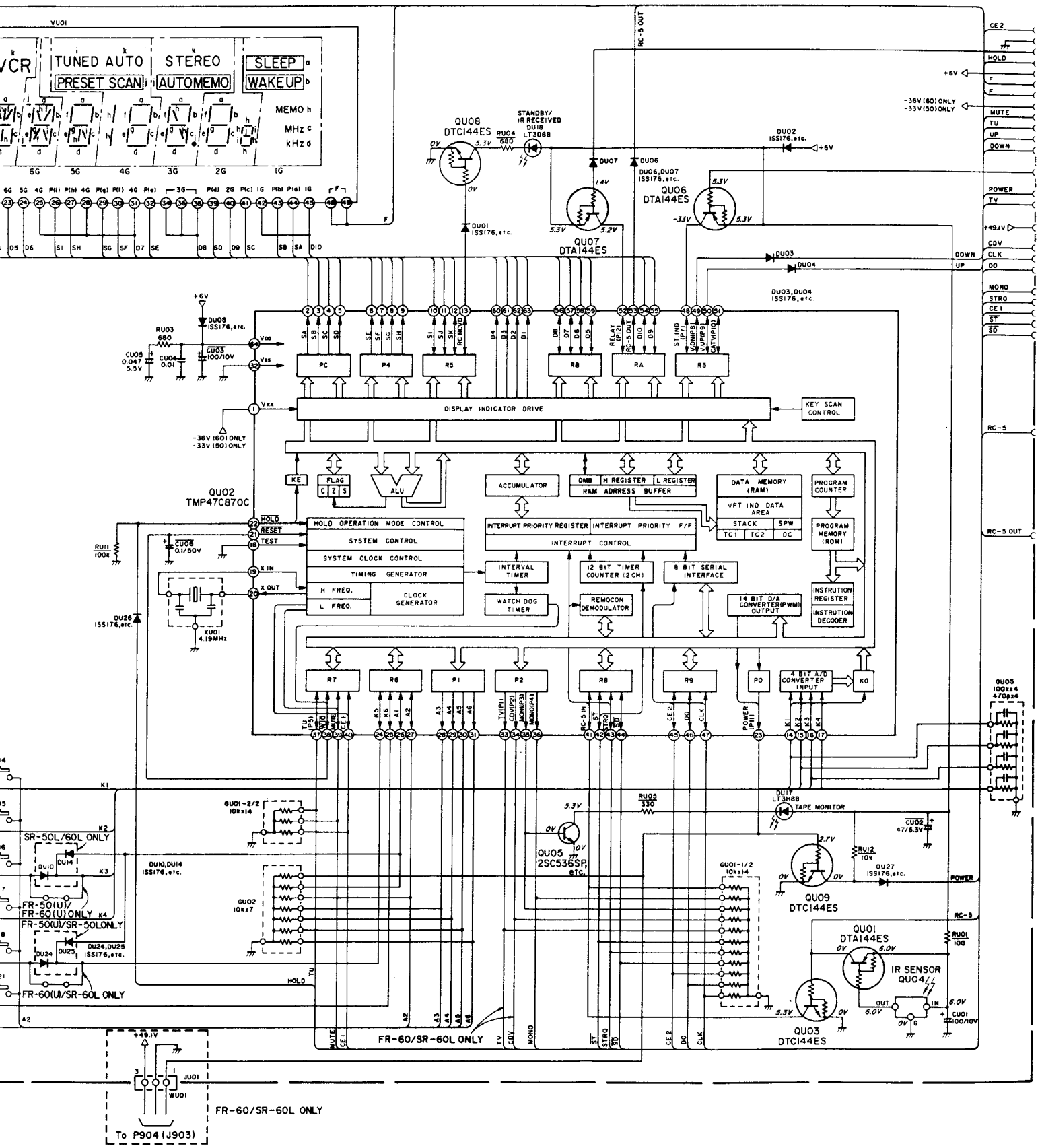

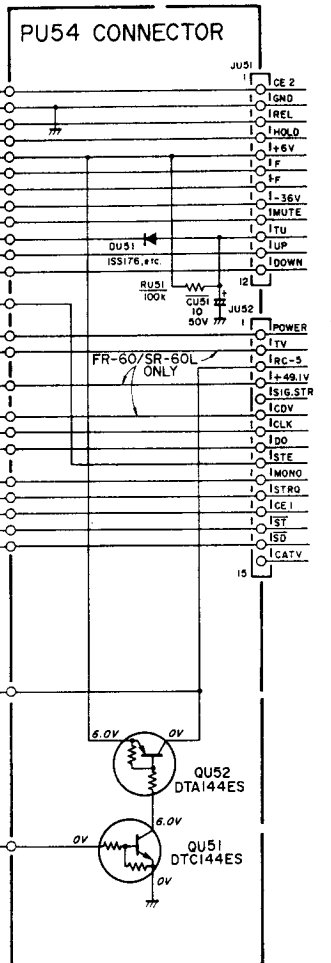
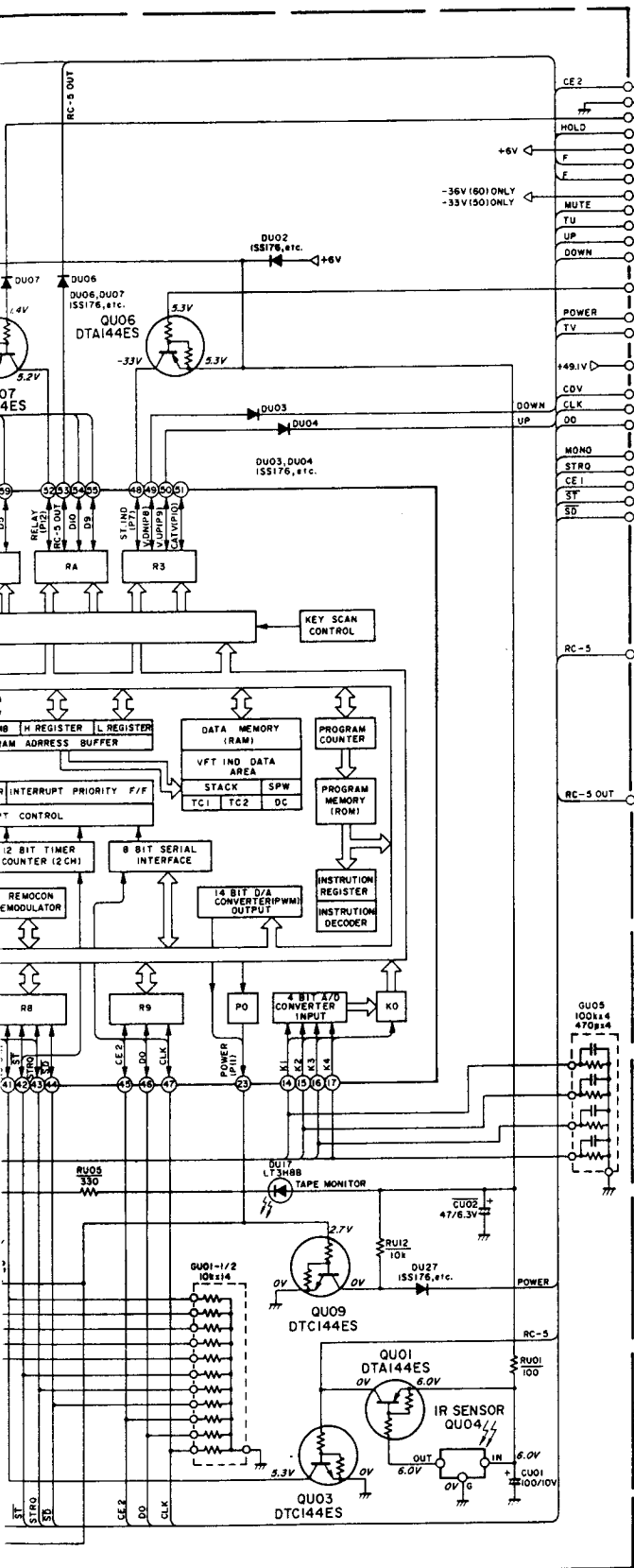

To PV04 (JV06)

To PV04 (JV07)

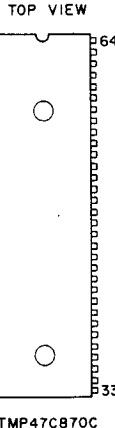
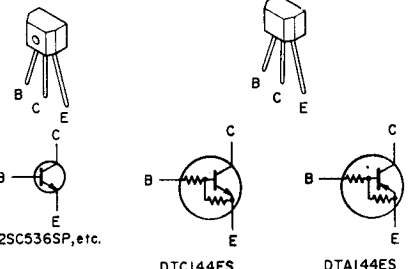

QU09

QU06

QU07

PU04

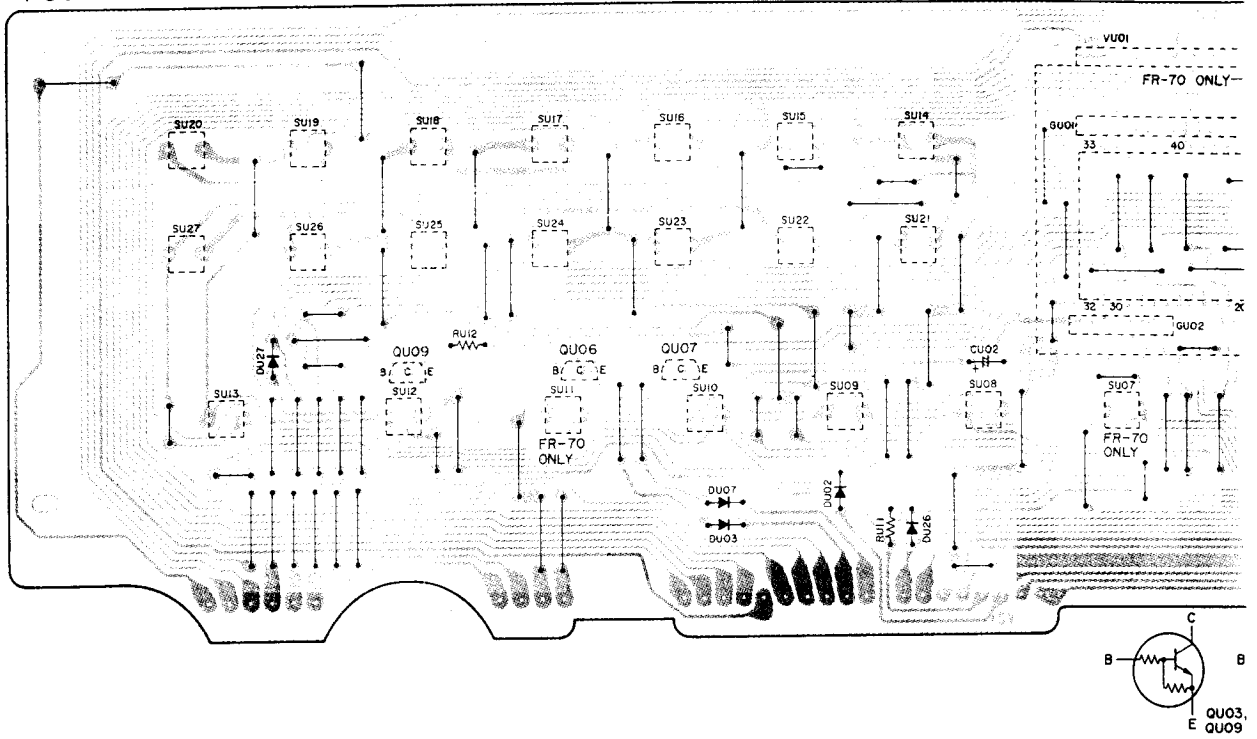

PU54

QU51 QU52

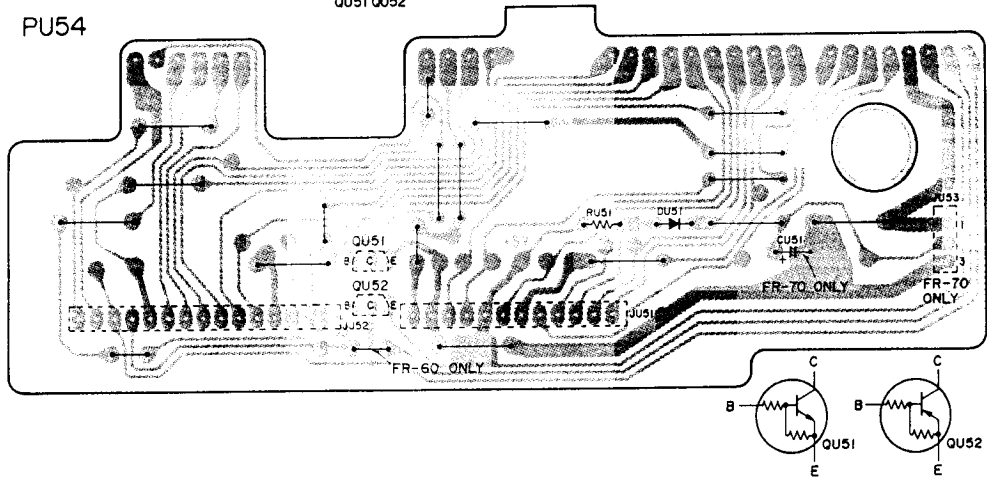

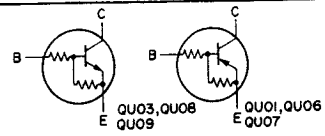
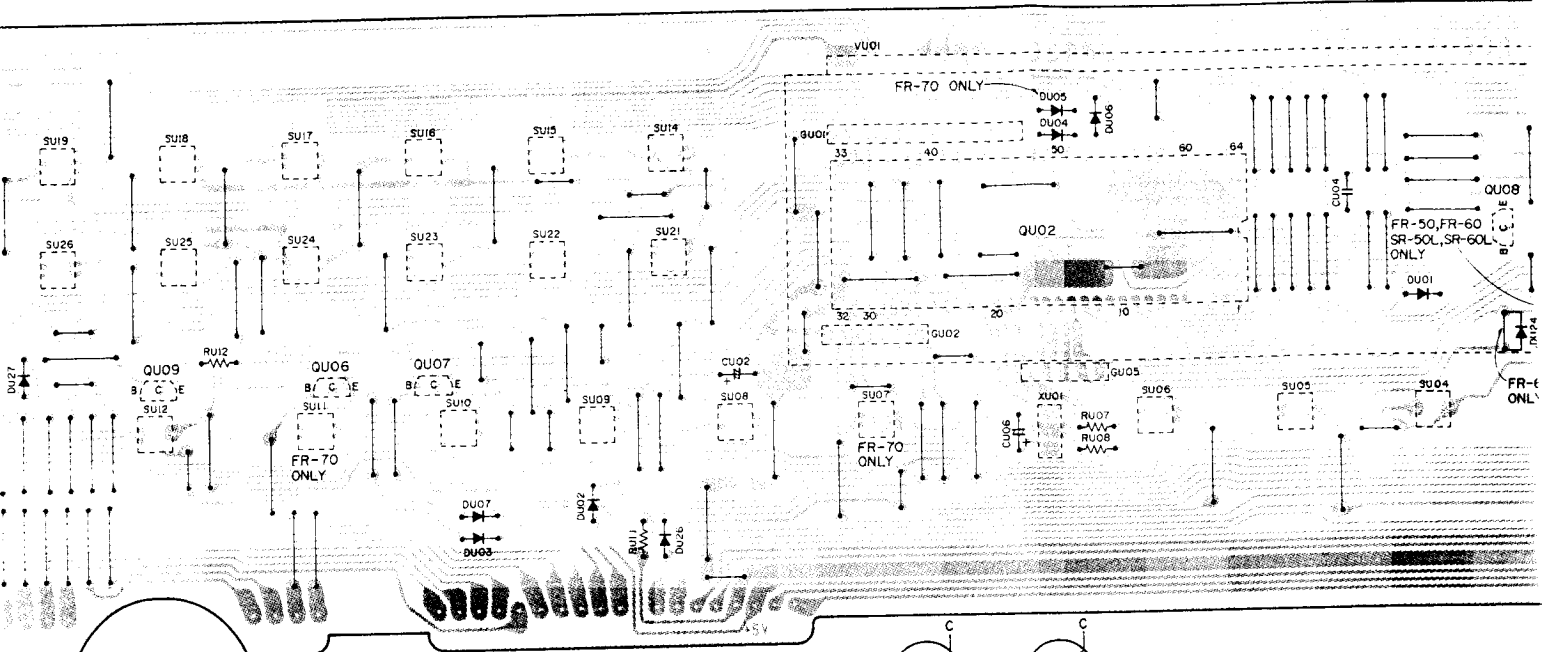

QU51 QU52

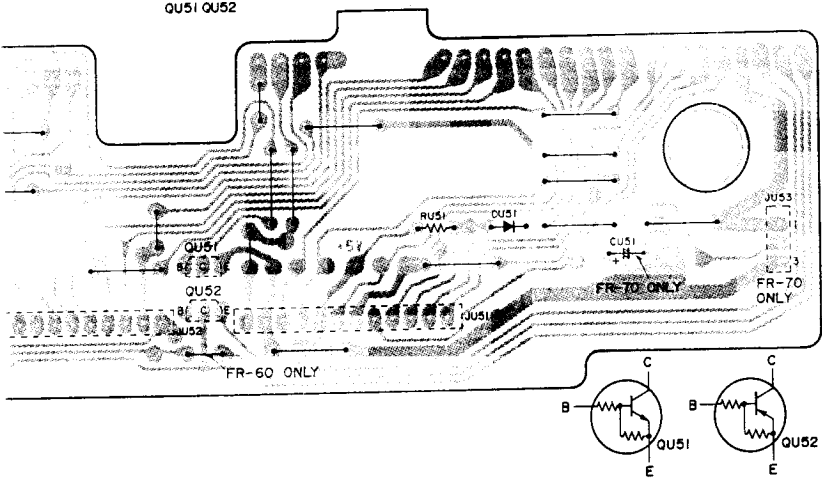

QU02

QU08

QU05

QU10

QU03 QU04 QU01

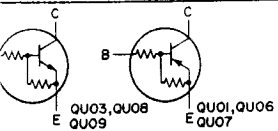
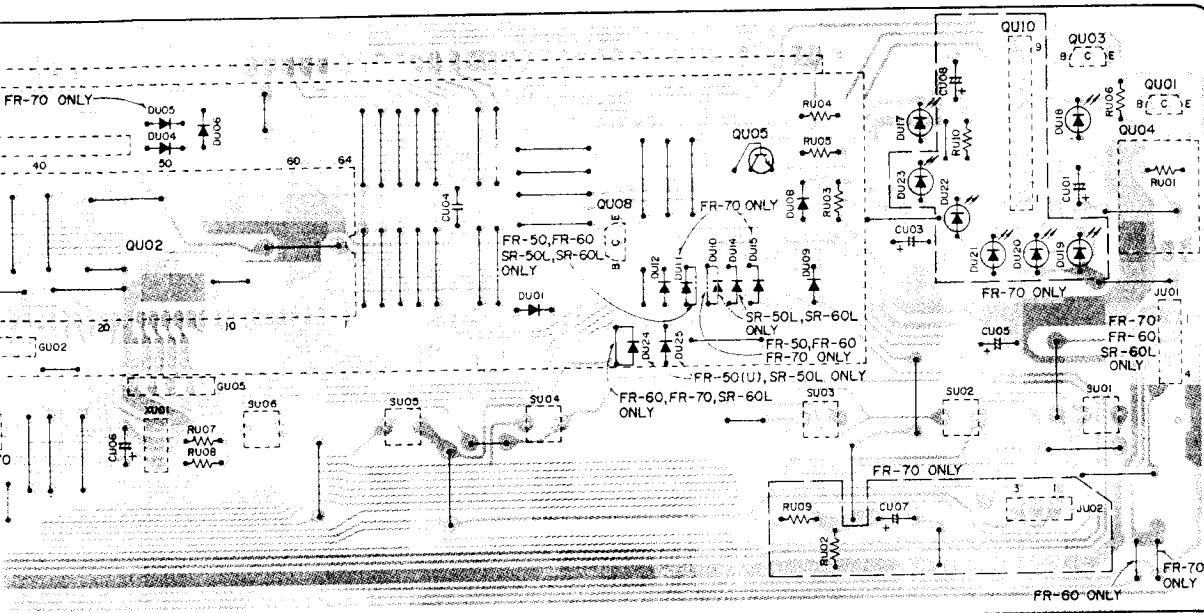

1
1

P904

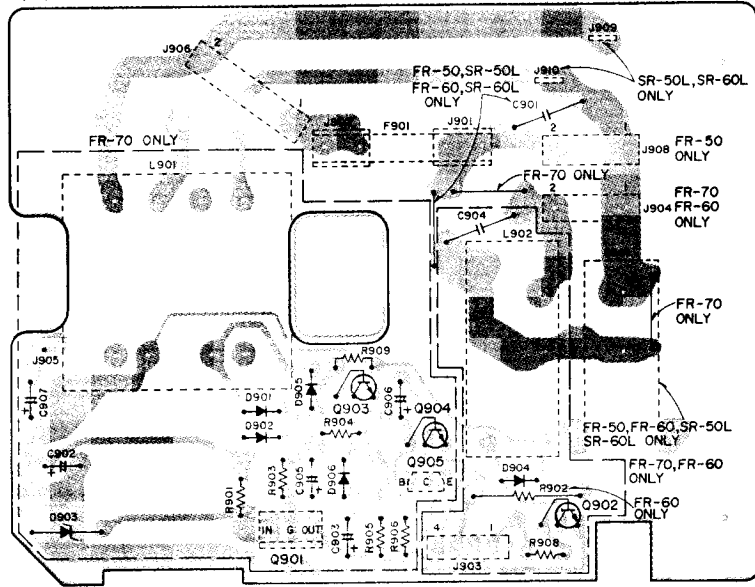

F901: 3A 125V FR-50 } (U) VERSION
 4A 125V FR-60 }
 5A 125V FR-70 }
 T1.0A 250V SR-50L } (A,T,W) VERSION
 T1.25A 250V SR-60L }

3

4

PG04

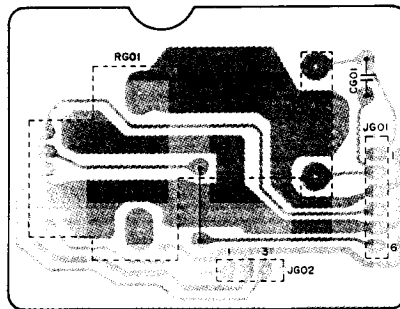

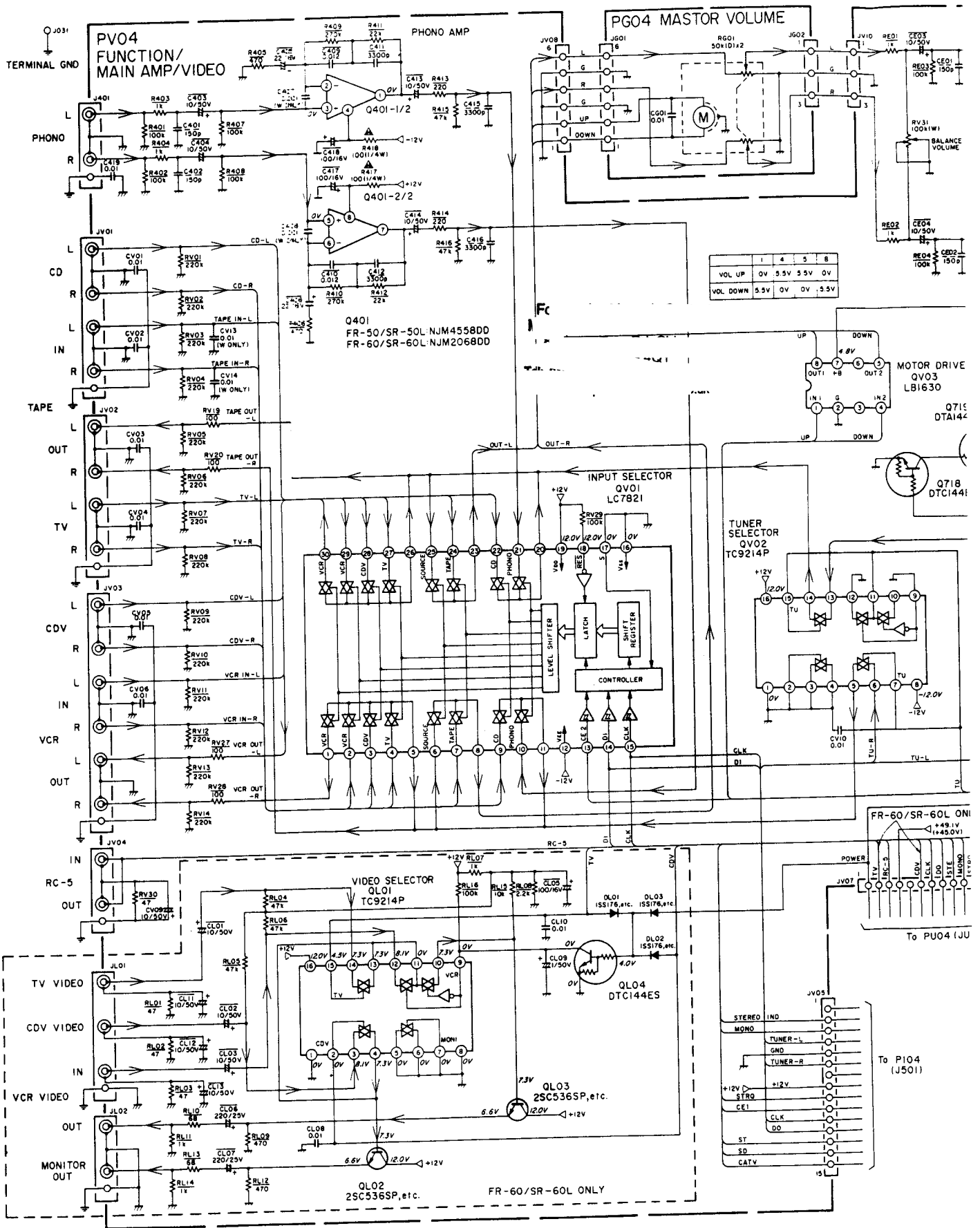

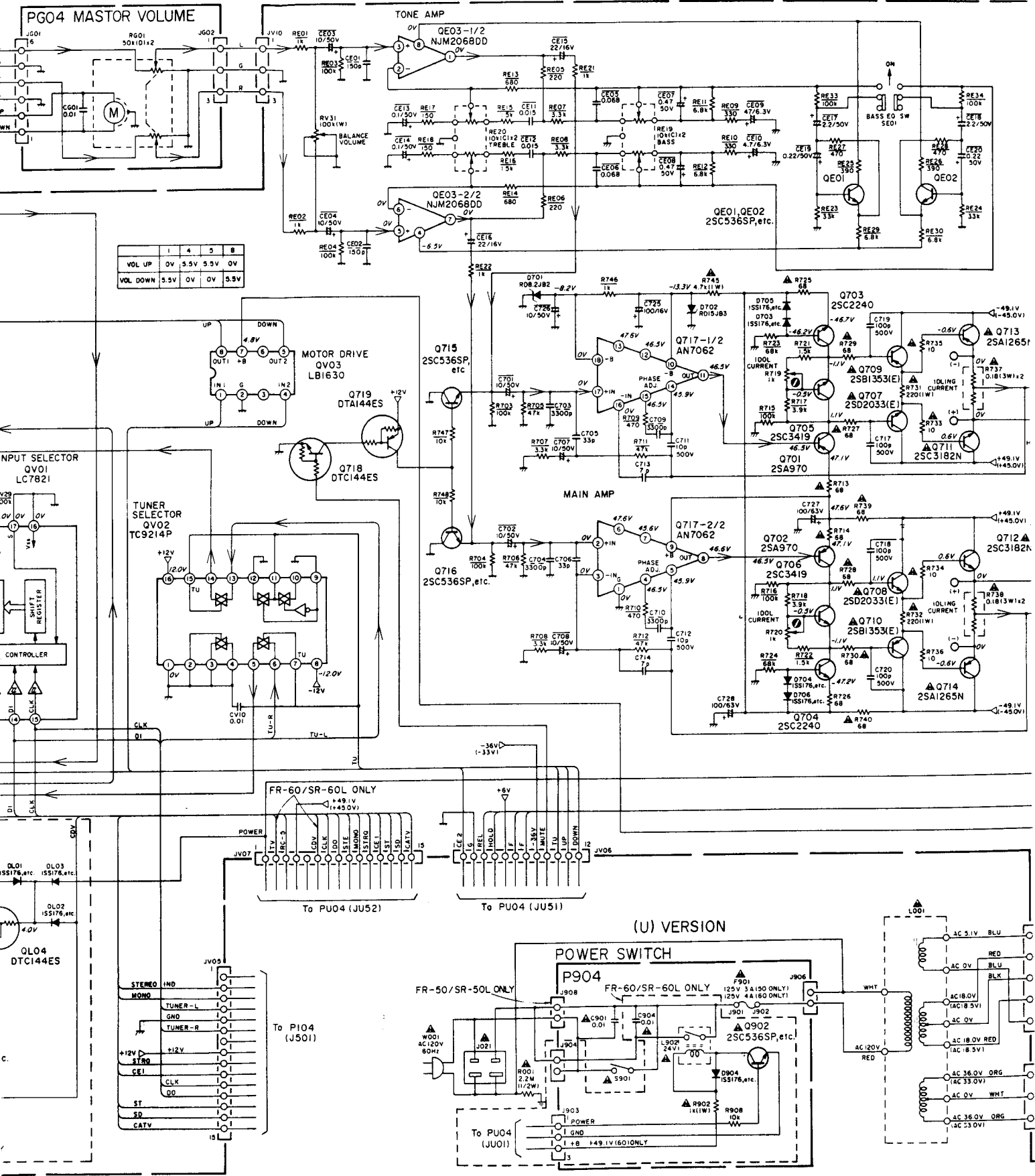

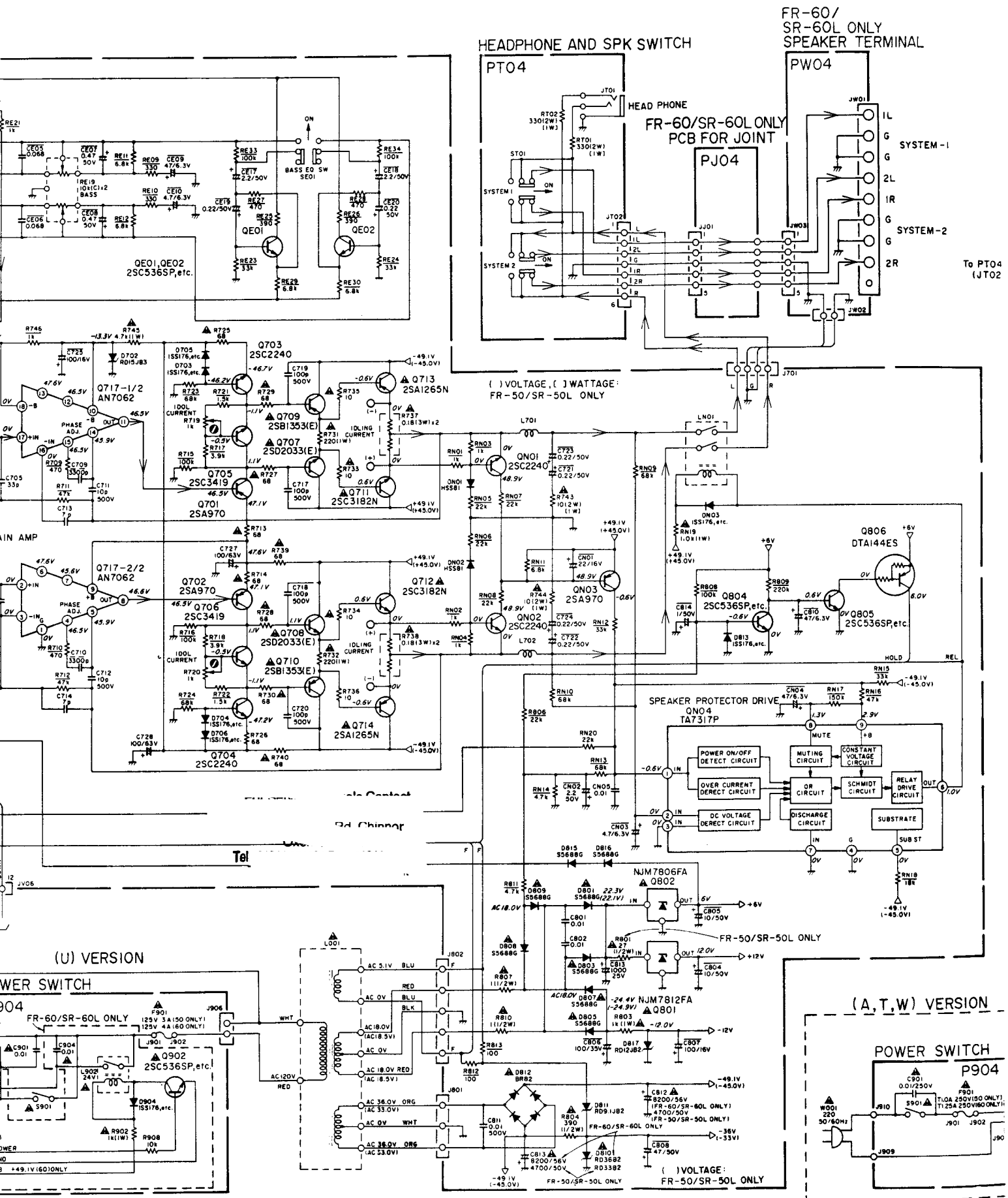

NOTE ON SAFETY:
 Symbol ▲ Fire or electrical shock hazard. Only original parts may be used to replace any part marked with symbol ▲. Any other component substitution (other than original type), may increase risk of fire or electrical shock hazard.

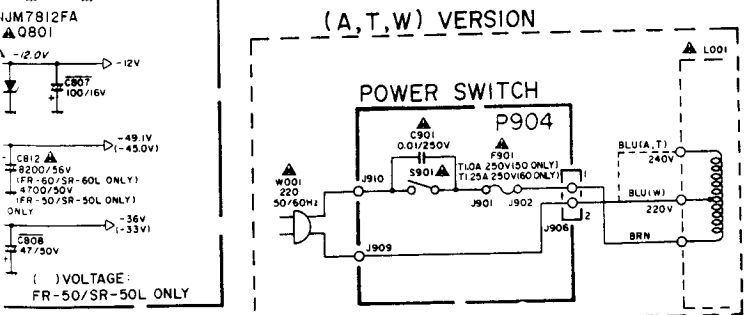
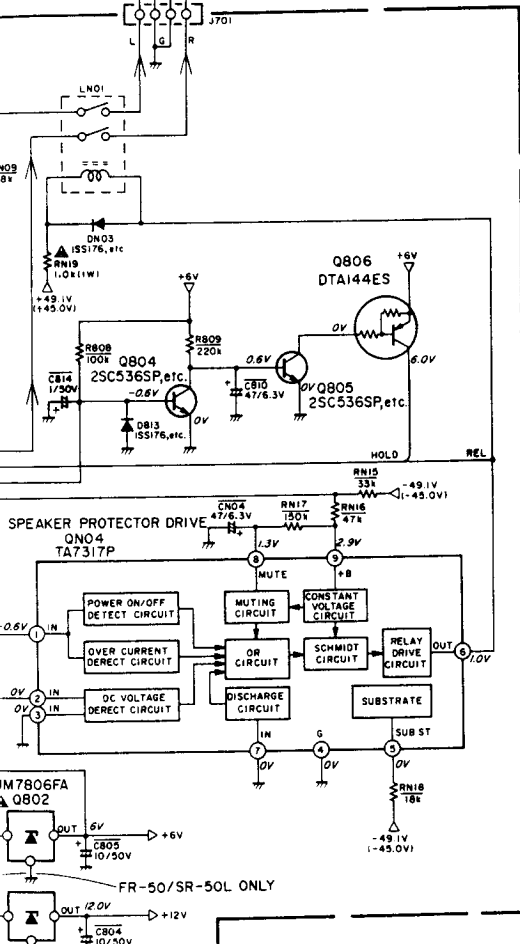
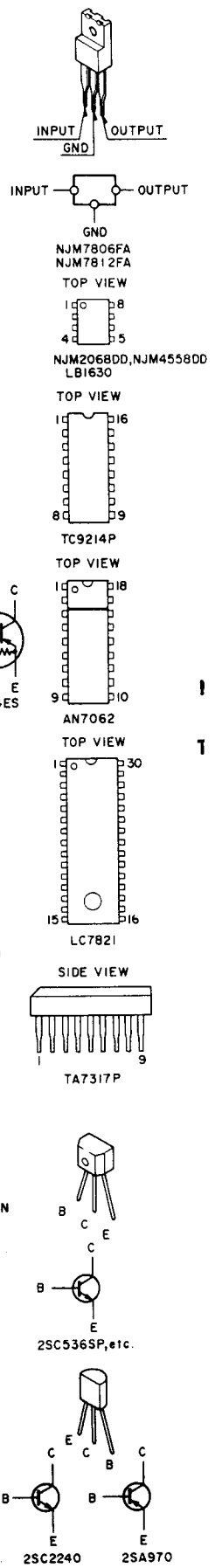
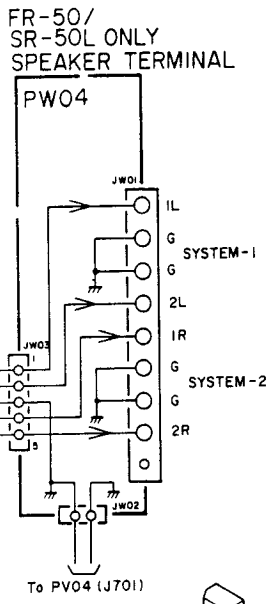
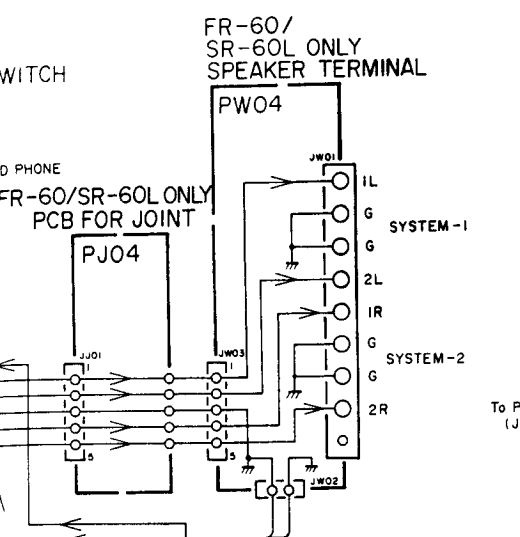

SAFETY:
Fire or electrical shock hazard. Only original parts should replace any part marked with symbol Δ . Any other substitution (other than original type), may increase risk of fire al shock hazard.

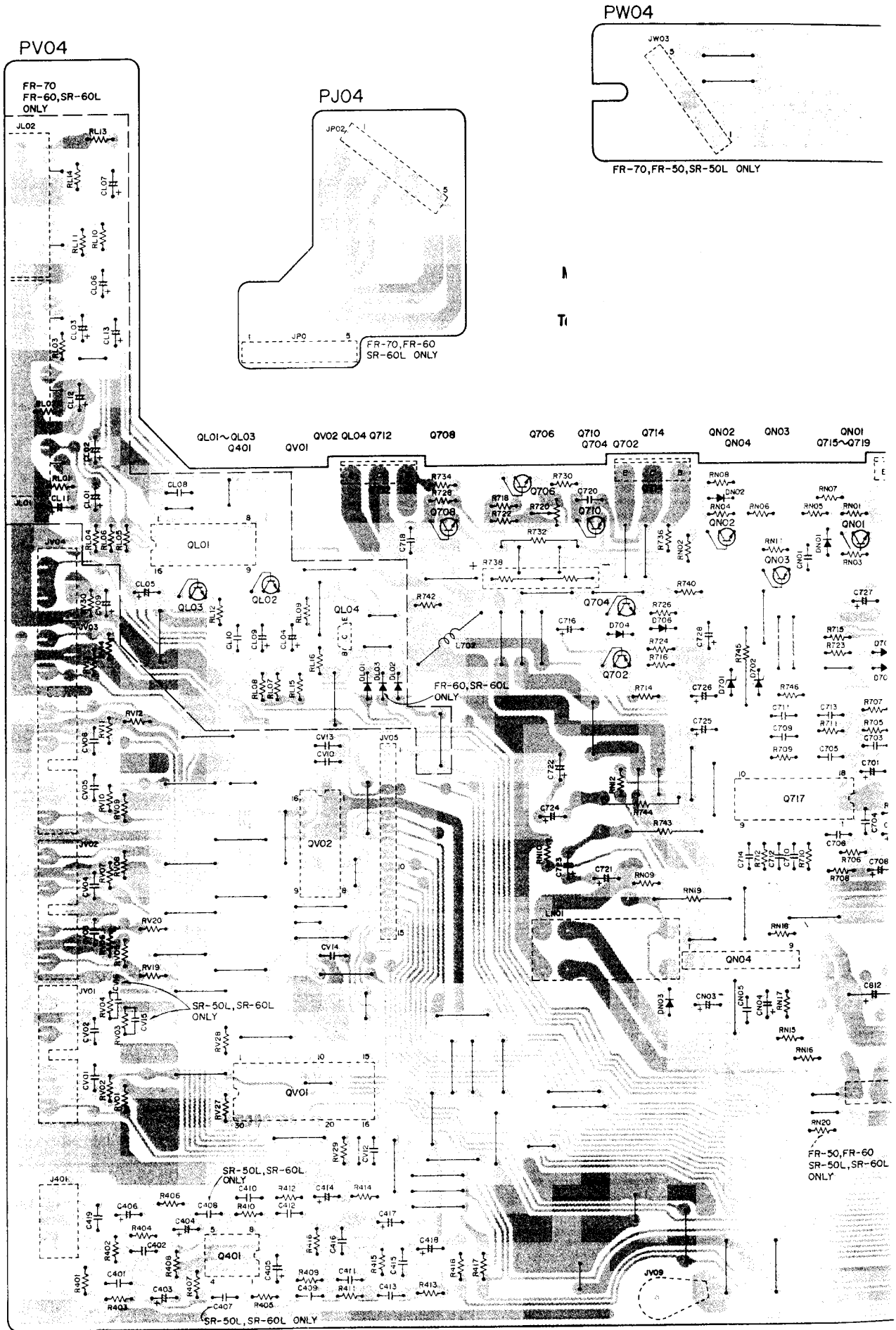

PW04

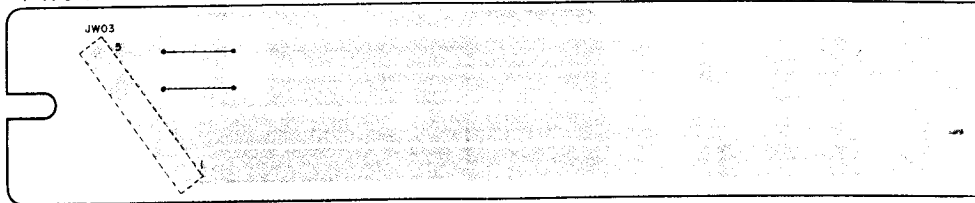

FR-70,FR-50,SR-50L ONLY

PJ04

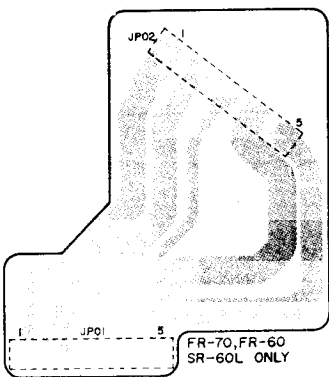

FR-70,FR-60
SR-60L ONLY

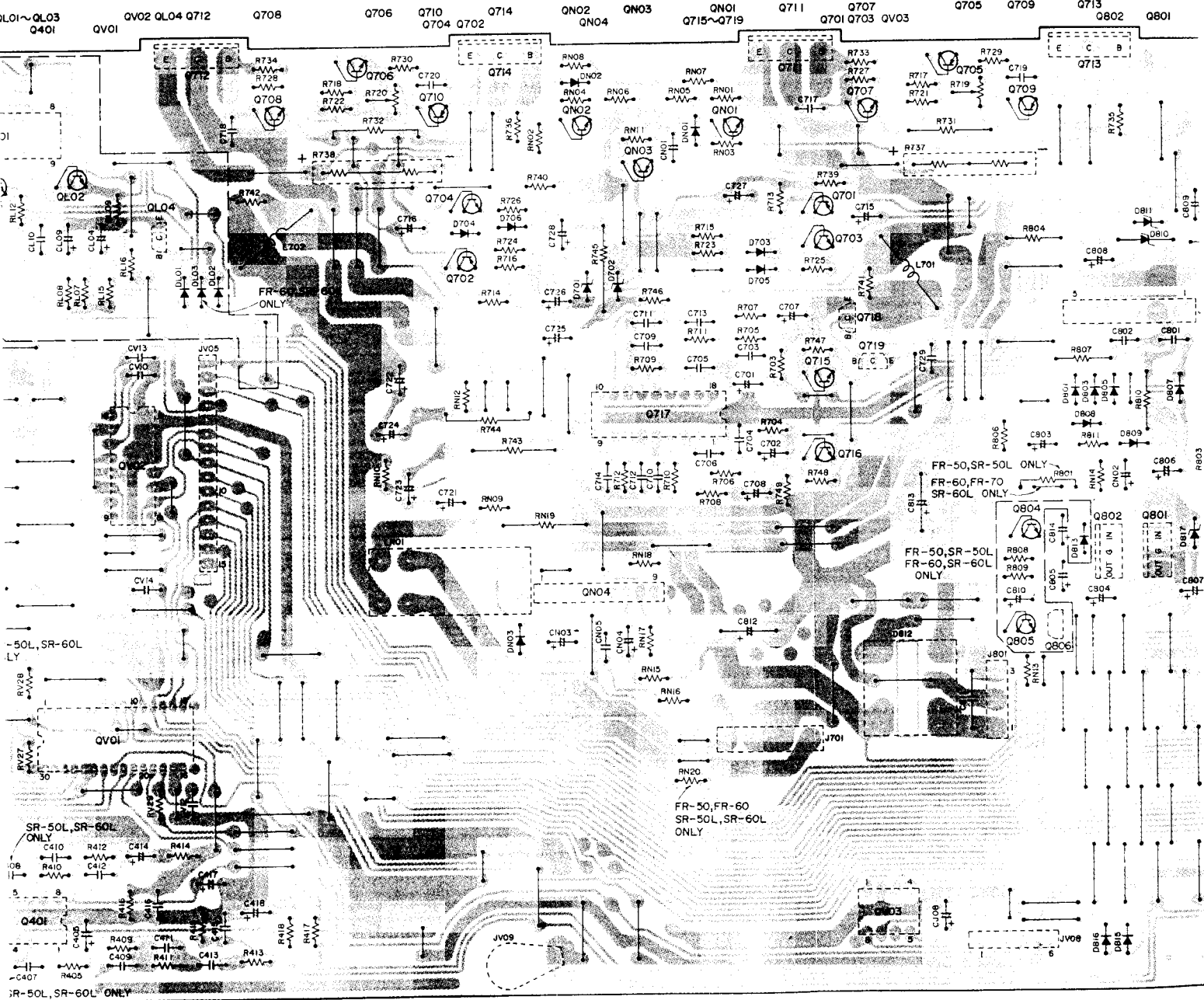

• WW54
 • WW52
 • WW55
 • WW53
 • WW51

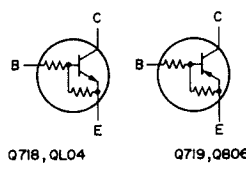
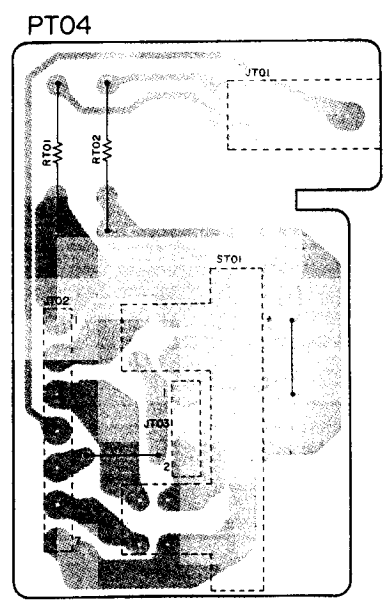
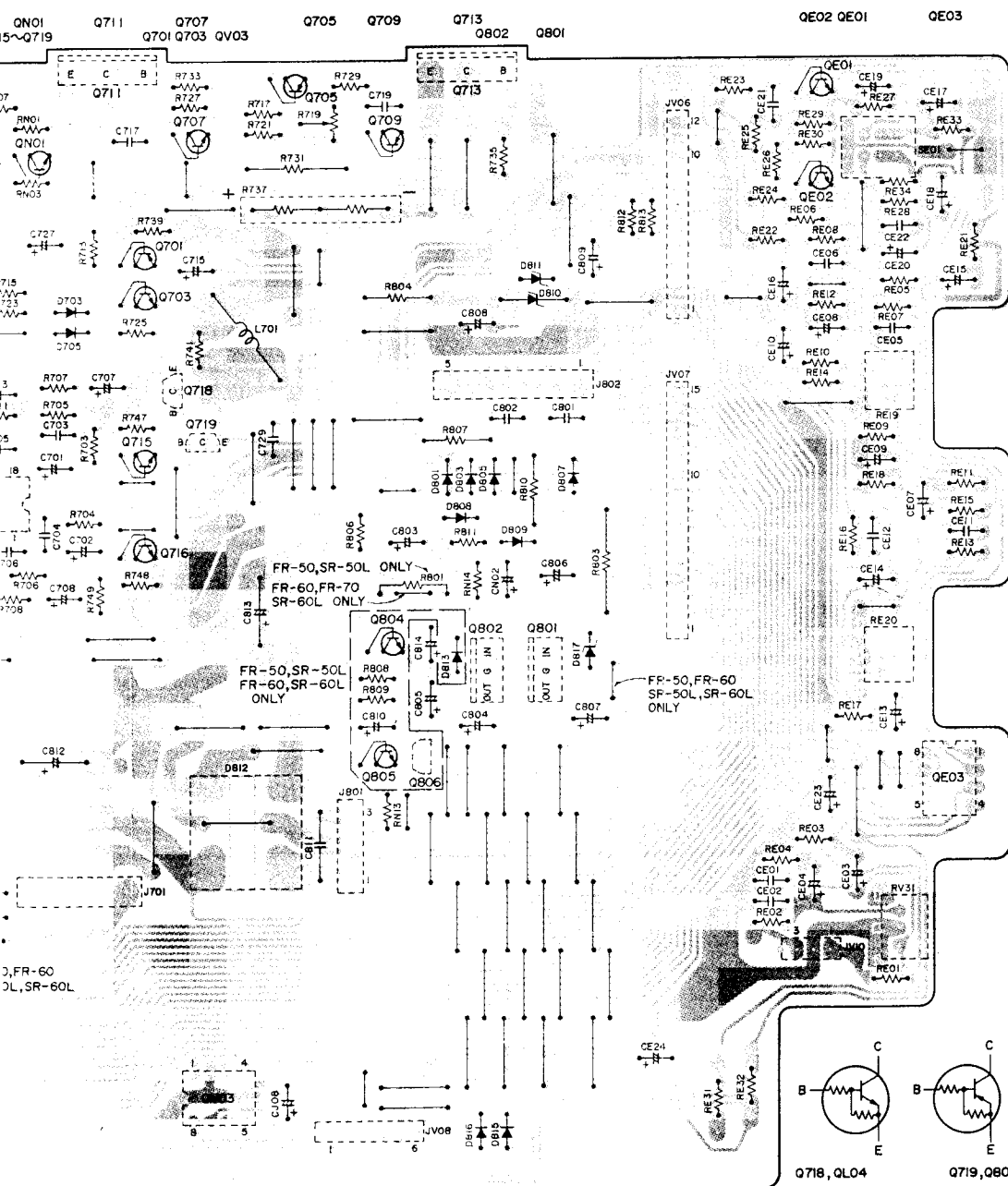

3. EXPLODED VIEW AND PARTS LIST

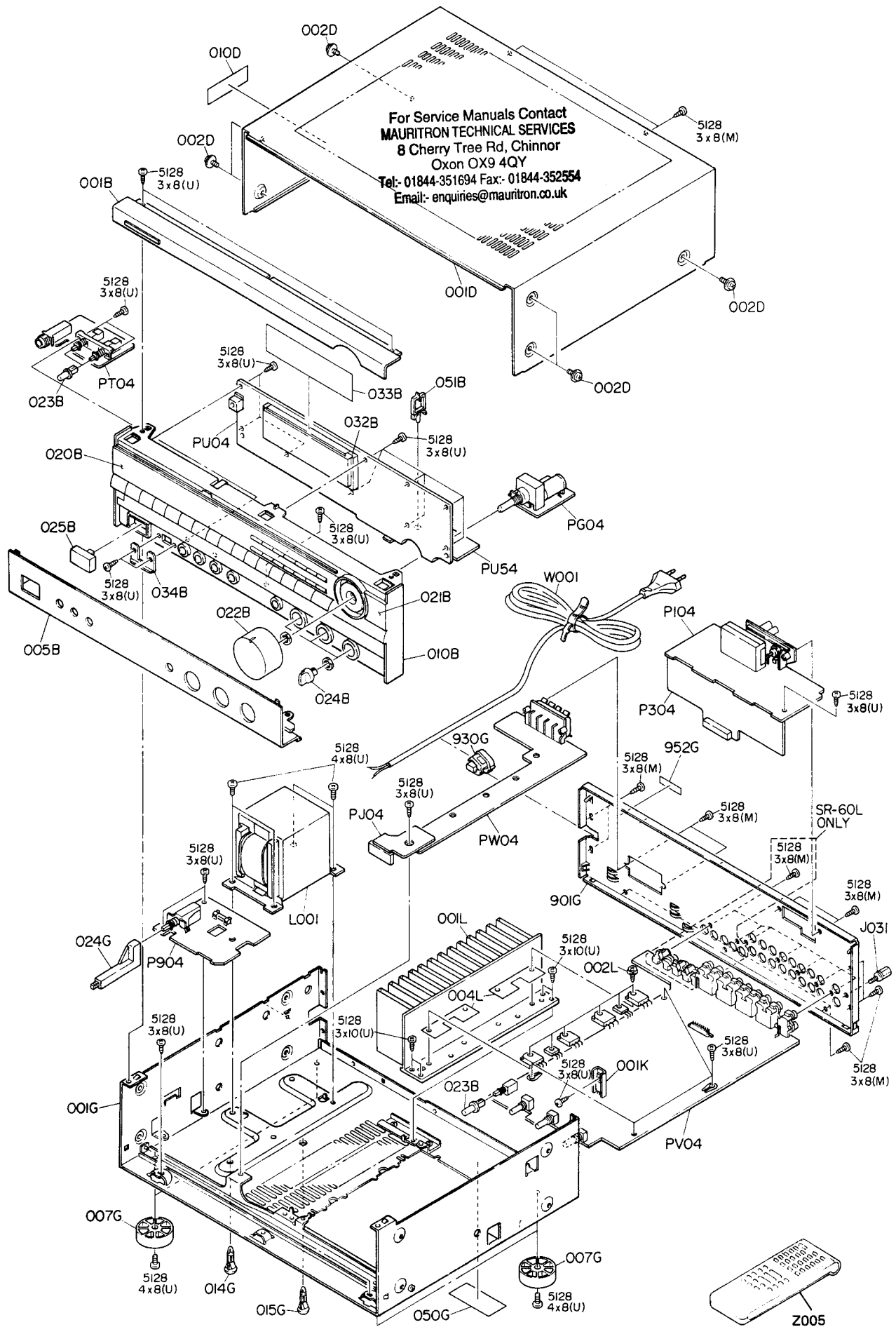

REF. DESIG.	PART NO.	DESCRIPTION
001B	4822 426 51418	Front Panel Assembly, Up (SR60L)
	4822 426 51421	Front Panel Assembly, Up (SR50L)
005B	4822 426 51416	Front Panel, Down
010B	4822 426 51415	Chassis Assembly, Front
020B	4822 450 61563	Window, Left
021B	4822 450 61566	Window, Right
022B	4822 413 41544	Knob, Volume
023B	4822 410 60343	Button
024B	4822 413 41523	Knob, Bal./Bass/Treble
025B	4822 410 60194	Button, Power
032B	4822 256 91642	Holder, FL
033B	4822 459 10942	Sticker, FL Adhesive
051B	4822 459 80343	Clamper
002D	4822 501 11008	B.T. Screw (W/W) B4 x 8
007G	4822 462 41477	Leg
024G	4822 276 12497	Link, Power Switch
930G	4822 532 60948	Bushing, AC Cord
J031	4822 290 40297	Terminal, GND
▲ L001	4822 146 21531	Power Transformer (SR60L)
	4822 146 21529	Power Transformer (SR50L)
001T	4822 736 20652	User Manual (SR60L)
	4822 736 20653	User Manual (SR50L)
Z005	4822 218 10351	Remote Control, RC-60SR

4. TEST EQUIPMENT REQUIRED FOR SERVICING

This table lists the test equipment required for servicing.

Item	Use
Distortion Analyzer	Distortion measurements
Audio Oscillator	Sinewave and squarewave signal source
ACVTVM	Voltage measurements (AC)
Oscilloscope	Waveform analysis and trouble shooting and ASO aignment
Circuit Tester	Trouble shooting
DCVTVM	Voltage measurements (DC)
AC Wattmeter	Monitors primary power to amplifier
Line Voltmeter	Monitors potential of primary power to amplifier
Variable Autotransformer	Adjust level of primery power to amplifier
Shorting Plug	Shorts amplifier input to eliminate noise pickup

5. IDLING CURRENT ADJUSTMENT

- (1) Before switching the power ON, set the Master Volume control to the minimum position and the Balance and Tone controls to the center positions. Then, rotate the semi-fixed resistors R719 (L CH) and R720 (R CH) on the PC board PV04 fully clockwise.
- (2) Connect a digital voltmeter, set for the DC voltage input to the pertinent test points (the marked ones of R737-R738) on the PC board PV04. (Positive: Rear side, Negative: Front side)
- (3) After the completion of the above setup. Switch the power ON and adjust the semi-fixed resistors R719 (L CH) and R720 (R CH) on the PC board PV04 according to the reading of the digital voltmeter. The setting values are 6 ~ 7.6 mV (16.7 ~ 20 mA) of the both channels.

Please refer to the table below.

Power ON

20 sec later	2mV
1 min later	4mV
More than 5min	6 ~ 7.6mV

Measurement point

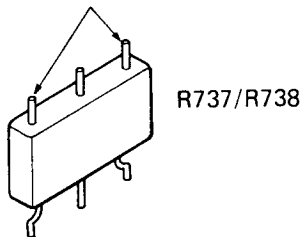

7. HOW TO CHANGE THE SUPPLY VOLTAGE (T.W. Versions)

Refer to the following diagram for the voltage change procedure.

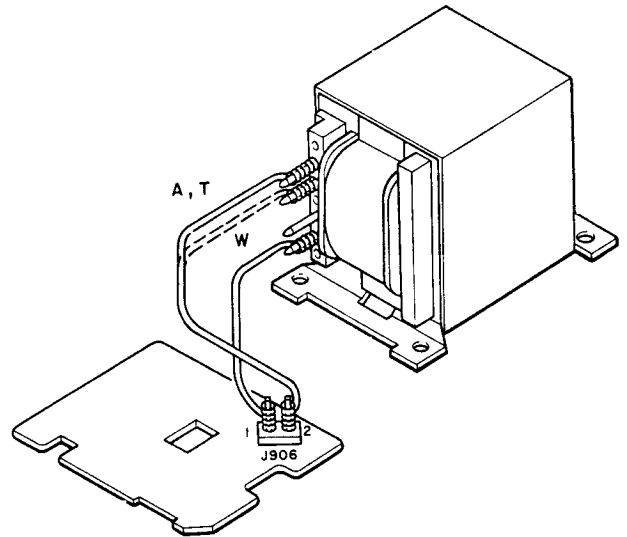

6. VOLTAGE CONVERSION

● EUROPEAN MODEL ONLY

To convert the unit to a different power source voltage, change the position as illustrated in the drawing below.

VOLTAGE SELECTOR

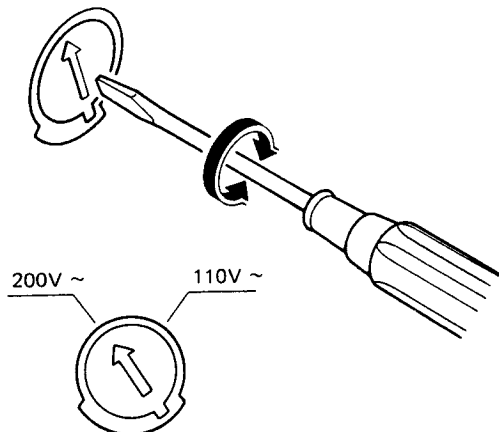

CAUTION
DISCONNECT POWER SUPPLY CORD FROM AC
OUTLET BEFORE CONVERTING VOLTAGE.

8. SERVICE PROGRAM

1. T.R POINT ME (tracking point memory) mode.

From power OFF (backup mode), when the power switch is pressed ON while pressing the up and MEMO key simultaneously, the T.R POINT ME mode is called.

Frequencies to be memorized are as follows.

	P1	P2	P3	P4	P5	P6	P7	P8
FM	90.0 MHz	98.0 MHz	106.0 MHz	87.5 MHz				
AM (with LW)					603 kHz	999 kHz	1404 kHz	173 kHz
AM (without LW)					603 kHz	999 kHz	1404 kHz	531 kHz
AM (USA)					600 kHz	1000 kHz	1400 kHz	520 kHz

	P9	P10	P11	P12-P30
FM				
AM (with LW)	209 kHz	272 kHz	152 kHz	531 kHz
AM (without LW)	531 kHz	531 kHz	531 kHz	531 kHz
AM (USA)	520 kHz	520 kHz	520 kHz	520 kHz

2. Microprocessor and FL operation check program mode

2-1 FL segment check

- This program is to check each FL segment for its lighting.
 - When the test mode is entered, microprocessor's MUTE OUT becomes "HIGH" to apply muting to the unit itself. No change occurs in any other setting.
 - At first, every segment is aliget. for 3 seconds.

2-2 Service mode (input selector check)

- This program is to check the input selector, etc. of the unit itself for functioning.
 - Microprocessor's MUTE OUT is made "LOW".
 - In a procedure shown in the following, each object is subject to execution of check for 3 seconds, and operation shifts to the next one. Then, operation starts at step 1.
 - At the time of object change, muting is applied at the aforesaid timing.
 - When the final step is executed, operation returns to step 1 to repeat.
 - When the \uparrow key is pressed, operation shifts to the next step. However, in this case, any continuous pressure of this key is not accepted. Operation is stopped by the O/C key and is resumed by the \uparrow key. Either is always accepted.

Step	Function	Notes
1	FM	FM mode: Auto, last frequency (initial)
2	FM	FM mode: Mono, last frequency (initial)
3	PHONO	
4	CD	
5	TAPE	
6	TV	
7	CDV	
8	VCR	

9. TUNER ALIGNMENT PROCEDURES

- When you adjust a set, use a signal generator with a counter with which you can correctly read frequencies, or connect a counter to a signal generator with a counter terminal for both AM and FM.
- As a rule, use a band-pass filter (B.P.F 200-15 kHz) designated by IHF in adjustment and measurement of FM.
Be sure to use a filter especially in adjustment of STEREO DISTORTION and SEPARATION. (Attenuation at 19 kHz is to be 30 dB at least.)
- The controller (QU02) used in this set has a function to preset and memorize the frequencies of guard and tracking point to be used in adjustment and measurement.

Caution:

Alignment of FM needs to set the IF BAND SWITCH to "WIDE" position if any other instruction does not require.

4. Adjustment of FM MPX VCO

The part to be adjusted: R314

- Set the frequency and output of the signal generator at 98 MHz and 500 μ V (54 dB)/75 ohms respectively and synchronize the set to them.
- After confirming that the "TUNED" indicator in FL display is not turned off when you set FM MODE SWITCH in AUTO STEREO position (AUTO is alight), turn off the modulation of the signal generator.
- After connecting a frequency counter to the test point, UP15, adjust R314 so that the frequency counter shows 228 (± 0.05) kHz.

P304

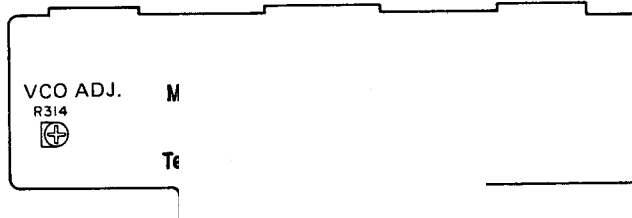

- Set to T.R point ME mode of the service program, after that, needs POWER OFF and POWER ON again. (P1) to (P7) in the Digital Readout Frequency Setting column shows preset numbers for the above mode. Before alignment, connect a dummy resistor of 47 kohms to the tape out terminal.

5. FM Alignment Procedures

(Function switch at "FM" position and MODE switch at "MONAURAL" position)

• FM RF Alignment

Step	Signal Source Connection	Signal Frequency	Indicator Connection	Digital Readout Frequency Setting	Adjust
1	FM signal generator to FM antenna terminal. Adjust the RF signal output so that slight noise occurs at the upper and lower sides of the output waveform.	98.0 MHz	AC VTVM to L- or R-channel output (TAPE OUT)	98.0 MHz (P2)	Front end IFT for maximum output and minimum distortion.
2	FM signal generator 500 μ V output to FM antenna terminal (75-ohm).	98.0 MHz		98.0 MHz (P2)	
3	For Service Manuals Contact MAURITRON TECHNICAL SERVICES 8 Cherry Tree Rd, Chinnor Oxon OX9 4QY Tel: 01844-351694 Fax: 01844-352554 Email: enquiries@mauritron.co.uk		Distortion meter to L- or R-channel output (TAPE OUT)		L201 core for minimum distortion.

• FM IF Alignment

(Function switch at "FM" position and MODE switch at "AUTO STEREO" position)

Step	Signal Source Connection	Signal Frequency	Indicator Connection	Digital Readout Frequency Setting	Adjust
1	FM signal generator 500 μ V output modulated by MPX signal generator to FM antenna terminal (75-ohm).	Stereo L-channel (1,000 Hz)	VTVM to L-channel output (TAPE OUT L channel)	98.0 MHz (P2)	Front end IFT for minimum distortion.
2	Modulation level: IHF 67.5 kHz +9% pilot dev. DIN 40 kHz +8% pilot dev.	Stereo R-channel (1,000 Hz)	VTVM to R-channel output (TAPE OUT R channel)		

• Muting Level Alignment

(Function switch at "FM" position and MODE switch at "AUTO STEREO" position)

Step	Signal Source Connection	Signal Frequency	Indicator Connection	Digital Readout Frequency Setting	Adjust
1	FM signal generator 6.3 μ V output to FM antenna terminal (75-ohm)	98.0 MHz		98.0 MHz (P2)	R211 to a point at which shows "tuned."

● **Multiplex Alignment**

(Function switch at "FM" position and MODE switch at "AUTO STEREO" position)

Step	Signal Source Connection	Signal Frequency	Indicator Connection	Digital Readout Frequency Setting	Adjust
1	FM signal generator 500 μ V output modulated by MPX signal generator to FM antenna terminal (75-ohm) Modulation level: IHF 67.5 kHz +9% pilot dev. DIN 40 kHz +8% pilot dev.	Stereo L-channel (1,000 Hz)	VTVM to R-channel output (TAPE OUT R channel)	98.0 MHz (P2)	R301 so that channel separation is identical between both channels.
2		Stereo R-channel (1,000 Hz)	VTVM to L-channel output (TAPE OUT L channel)		
3	Repeat steps 1 and 2.				

6. AM/MW Alignment Procedures

(Function switch at "AM" position)

● **AM IF Alignment**

Step	Signal Source Connection	Signal Frequency	Indicator Connection	Digital Readout Frequency Setting	Adjust
1	Sweep generator to AM antenna terminal	450 kHz	AC VTVM to L- or R-channel output (TAPE OUT)	—	FA01 for Europe versions, LA06 Europe USA, versions maximum and symmetrical waveform.

● **AM RF Alignment**

Step	Signal Source Connection	Signal Frequency	Indicator Connection	Digital Readout Frequency Setting	Adjust
1	AM signal generator to AM loop antenna in a test loop	603 kHz	VTVM to L- or R-channel output (TAPE OUT)	603 kHz (P5)	LA01 for maximum output.
2		1,404 kHz		1,404 kHz (P7)	CA01 for maximum output.
3	Repeat steps 1 and 2 until sensitivity is maximized.				

● **LW RF Alignment**

(For Europe version)

Step	Signal Source Connection	Signal Frequency	Indicator Connection	Digital Readout Frequency Setting	Adjust
1	AM signal generator to AM loop antenna in a test loop	173 kHz	VTVM to L- or R-channel output (TAPE OUT)	173 kHz (P8)	LA03 for maximum output.
2		272 kHz		272 kHz (P10)	CA08 for maximum output.
3	Repeat steps 1 and 2 until sensitivity is maximized.				

- AM Auto Stop Alignment
(Function switch at "AM" position)

Step	Signal Source Connection	Signal Frequency	Indicator Connection	Digital Readout Frequency Setting	Adjust
1	RF generator to AM loop antenna in a test loop (500 $\mu\text{V}/\text{m}$)	999 kHz	—	999 kHz (P6)	RA13 so that shows "TUNED" on the display tube lights.

10. ALIGNMENT POINTS AND TEST POINTS

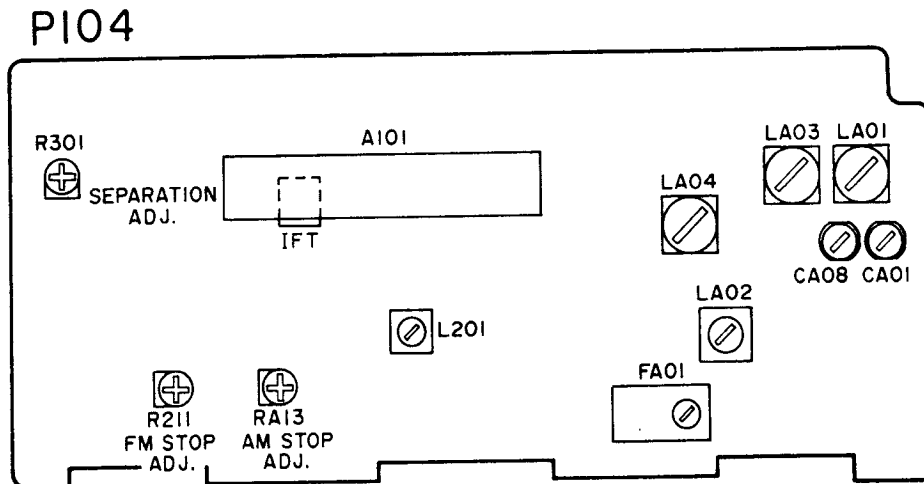

11. TUNER MICROPROCESSOR SPECIFICATIONS

1. Receiving Frequency Range, Channel Space, Reference Frequency and Intermediate Frequency

		Receiving Frequency	Channel Space	Reference Frequency	Intermediate Frequency
Japan	FM	76.0~90 MHz	100 kHz	25 kHz	-10.7 MHz
	AM	531~1602 kHz	9 kHz	9 kHz	+450 kHz
U.S.A.	FM	87.5~108.0 MHz	100 kHz	25 kHz	+10.7 MHz
	AM	520~1710 kHz	10 kHz	10 kHz	+450 kHz
Europe	FM	87.50~108.00 MHz	50 kHz	25 kHz	+10.7 MHz
	MW	531~1602 kHz	9 kHz	9 kHz	+450 kHz
	LW	152~282 kHz	1 kHz	1 kHz	+450 kHz

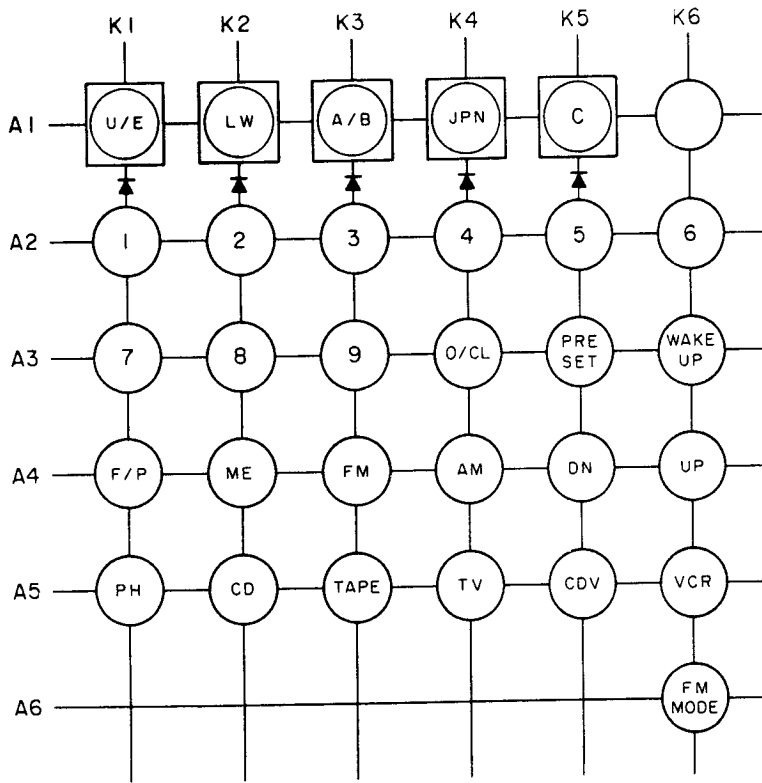

(For initial settings)

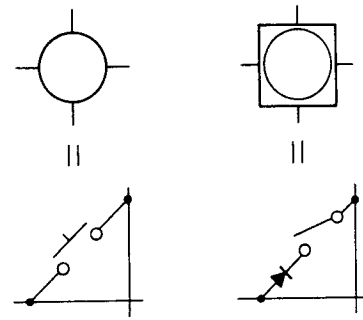

MODEL:
 A: FR-60/SR-60/60L
 B: FR-70
 C: FR-50/SR-50/50L

2. Diode switches (for initial settings)

- 1) : Band setting or selection between USA, Europe and Japan
 : 1 (ON setting) for Europe band
 0 (OFF setting) for USA band
 : 1 for Japan band
- 2) : Band setting for models with LW
 When this switch is set to "1", the Europe model is engaged unconditionally, thus having LW.
 (Independent of the switch occurring at the above item 1))
- 3) : This microprocessor is compatible with 3 models.
 When is set to "1", model B is engaged.
 When is set to "1", model C is engaged.
 When either is set to "0", model A is engaged.

3. Description of keys

- 1) ~ : Numeral keys for preset memory, which are used in memorizing or calling for preset memory of the tuner. The key is also used in stopping of preset scan as well as clearing of preset memory.
- 2) : This key provides the preset scan mode. When this key is pressed, "PRESET SCAN" flickers at 0.5 cycle/sec on the FL display. Thus, within 5 seconds, when the or key is pressed, preset scan is started and "PRESET SCAN" flickers at 1 cycle/sec on the FL display.
- 3) : This switch selects an FL display mode between the frequency display and the preset No. display.

- 4) : This key is used in writing or clearing the preset memory.
 *The key is enabled for 5 seconds, during which period when no preset No. is input, operation returns to the just previous status.
 *Auto memory operation
 Scan is automatically applied to within the band, and any receivable stations are stored in preset memory in a successive manner. This feature is enabled due to the simultaneous pressures of the key and the or key.
- 5) : A numeral key. Besides, clearance of preset memory, stop of preset scan, stop of auto memory, etc.
- 6) : Pressed for FM reception
- 7) : Pressed for AM reception
 For a model with LW, this key selects between MW and LW in a cyclic manner. "MW" or "LW" appears on the FL display.
- 8) , : Frequency up/down for frequency mode, and preset channel up/down for preset mode
- 9) , , , , , : Each selects its corresponding function as the input.
- 10) : When the power is turned ON, a preprogrammed mode is output using a code of RC-5 to operate another connected unit.
- 11) : Selection between auto stereo and mono at FM

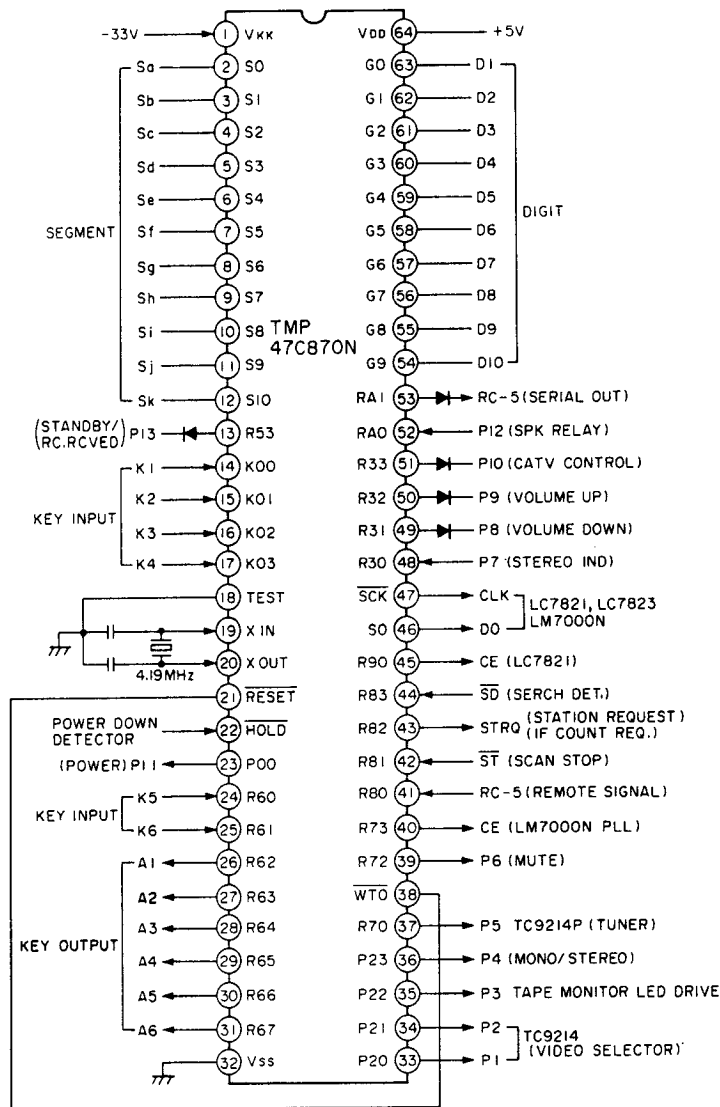

Port Name	Pin No.	I/O	Act	Function
VKK	1	-	-	-33V
S0	Sa	2	O	H
S1	Sb	3	O	H
S2	Sc	4	O	H
S3	Sd	5	O	H
S4	Se	6	O	H
S5	Sf	7	O	H
S6	Sg	8	O	H
S7	Sh	9	O	H
S8	Si	10	O	H
S9	Sj	11	O	H
S10	Sk	12	O	H
R53	P13	13	O	H
K00	K1	14	I	H
K01	K2	15	I	H
K02	K3	16	I	H
K03	K4	17	I	H
TEST	-	18	-	-
XIN	-	19	I	-
XOUT	-	20	O	-
RESET	-	21	I	L
HOLD	-	22	I	L
P00	P11	23	O	H
R60	K5	24	I	H
R61	K6	25	I	H
R62	A1	26	O	H
R63	A2	27	O	H
R64	A3	28	O	H
R65	A4	29	O	H
R66	A5	30	O	H
R67	A6	31	O	H
VSS	-	32	-	-

Port Name	Pin No.	I/O	Act	Function
P20	P1	33	O	H
P21	P2	34	O	H
P22	P3	35	O	H
P23	P4	36	O	H
R70	P5	37	O	H
WT0	-	38	O	L
R72	P6	39	O	H
R73	CE	40	O	H
R80	RC-5	41	I	L
R81	ST	42	I	L
R82	STRQ	43	O	H
R83	SD	44	I	L
R90	CE	45	O	H
SO	DO	46	O	H
SCK	CLK	47	O	H
R30	P7	48	O	H
R31	P8	49	O	H
R32	P9	50	O	H
R33	P10	51	O	H
RA0	P12	52	I	H
RA1	RC-5	53	O	H
G9	D10	54	O	H
G8	D9	55	O	H
G7	D8	56	O	H
G6	D7	57	O	H
G5	D6	58	O	H
G4	D5	59	O	H
G3	D4	60	O	H
G2	D3	61	O	H
G1	D2	62	O	H
G0	D1	63	O	H
VDD	-	64	-	-

12. ELECTRICAL PARTS LIST

ASSIGNMENT OF COMMON PARTS CODES.

RESISTOR

- R*****: (1) GD05 --- 140, Carbon film fixed resistor, $\pm 5\%$, 1/4W
R***: (2) GD05 --- 160, Carbon film fixed resistor, $\pm 5\%$, 1/6W

① — Resistance value

Examples

- ① Resistance value
 0.1 Ω ...001 10 Ω ...100 1k Ω ...102 100k Ω ...104
 0.5 Ω ...005 18 Ω ...180 2.7k Ω ...272 680k Ω ...684
 1 Ω ...010 100 Ω ...101 10k Ω ...103 1M Ω ...105
 6.8 Ω ...068 390 Ω ...391 22k Ω ...223 4.7M Ω ...475

(Note) Please distinguish 1/4W from 1/6W by the shape of parts used actually.

C***: CERAMIC CAP.

- (1) DD1 --- 370, Ceramic condenser
 Disc type
 Temp. coeff. P350 ~ N1000, 50V
- ① ②
 Capacity value
 Tolerance

Examples

- ① Tolerance (Capacity deviation)
 $\pm 0.25\text{pF}$...0
 $\pm 0.5\text{pF}$...1
 $\pm 5\%$...5

* Tolerance of COMMON PARTS handled here are as follows:

- 0.5pF ~ 5pF... $\pm 0.25\text{pF}$
 6pF ~ 10pF... $\pm 0.5\text{pF}$
 12pF ~ 560pF... $\pm 5\%$
- ② Capacity value
 0.5pF...005 3pF...030 100pF...101
 1pF...010 10pF...100 220pF...221
 1.5pF...015 47pF...470 560pF...561

C***: CERAMIC CAP.

- (1) DK16 --- 300, High dielectric constant ceramic condenser
 Disc type
 Temp. chara. 2B4, 50V
- ①
 Capacity value

Example

- ② Capacity value
 100pF...101 1000pF...102 10000pF...103
 470pF...471 2200pF...222

C***: ELECTROLY CAP. (E), FILM CAP. (F)

- (1) EA --- 10, Electrolytic condenser
 One-way lead type, Tolerance $\pm 20\%$
- ① ②
 Dielectric strength
 Capacity value

Examples

- ① Capacity value
 0.1 μF ...104 4.7 μF ...475 100 μF ...107
 0.33 μF ...334 10 μF ...106 330 μF ...337
 1 μF ...105 22 μF ...226 1100 μF ...108
 2200 μF ...228
- ② Working voltage
 6.3V...006 25V...025
 10V...010 35V...035
 16V...016 50V...050

- (2) DF15 --- 350, Plastic film condenser
 One-way type, Mylar $\pm 5\%$ 50V
- ①
 Capacity value

Examples

- ① Capacity value
 0.001 μF (1000pF)...102 0.1 μF ...104
 0.0018 μF ...182 0.56 μF ...564
 0.01 μF ...103 1 μF ...105
 0.015 μF ...153

REF. DESIG.	PART NO.	DESCRIPTION
		PG04-MASTER VOLUME CIRCUIT BOARD
CG01	4822 122 32486	Ceramic Cap. 0.01 μF +80% -20%
RG01	4822 100 30127	Variable Resistor 100K Ω (D)x2
		PT04-HEADPHONE/SPEAKER SW. CIRCUIT BOARD
RT01	4822 116 60262	Resistor 330 Ω $\pm 5\%$ 2W (SR60L)
	4822 111 50474	Resistors 330 Ω $\pm 5\%$ 1W (SR50L)
RT02	4822 116 60262	Resistor 330 Ω $\pm 5\%$ 2W (SR60L)
	4822 111 50474	Resistors 330 Ω $\pm 5\%$ 1W (SR50L)
JT01	4822 267 31126	Jack, Headphone
ST01	4822 276 20504	Push Switch, Speaker
		PU04-U-COM/TACT SW./FL CIRCUIT BOARD
CU04	4822 122 40586	Ceramic Cap. 0.01 μF $\pm 20\%$
CU05	4822 124 23128	Elect Cap. 0.047 μF 5.5V
GU01	4822 111 91936	Resistor, Array 10K Ω x14
GU02	4822 111 91678	Resistor, Array 10K Ω x7
GU05		Capacitor, Array 470pF/100K Ω x4
DU01		
}	4822 130 33305	Diode 1SS176, etc
DU04		
DU06		
}	4822 130 33305	Diode 1SS176, etc.
DU08		
DU10	4822 130 33305	Diode 1SS176, etc.
DU14	4822 130 33305	Diode 1SS176, etc.
DU15	4822 130 33305	Diode 1SS176, etc.
DU17	4822 130 80325	L.E.D. LT3H88 (YEL)
DU18	4822 130 80326	L.E.D. LT3D8B (RED)
DU24	4822 130 33305	Diode 1SS176, etc. (SR50L)
DU25	4822 130 33305	Diode 1SS176, etc. (SR50L)
DU26	4822 130 33305	Diode 1SS176, etc.
DU27	4822 130 33305	Diode 1SS176, etc.
QU01	4822 130 42682	Transistor, Digital DTA144ES
QU02	4822 209 62558	Microprocessor TMP47C870N
QU03	4822 130 42594	Transistor, Digital DTC144ES
QU04	4822 209 82139	Photo Unit PAS-C0617
QU05	4822 130 42298	Transistor 2SC536SP, etc.
QU06	4822 130 42682	Transistor, Digital DTA144ES
QU07	4822 130 42682	Transistor, Digital DTA144ES
QU08	4822 130 42594	Transistor, Digital DTC144ES
QU09	4822 130 42594	Transistor, Digital DTC144ES
SU01		
}	4822 276 12455	Push Switch, Tact
SU06		
SU08		
}	4822 276 12455	Push Switch, Tact
SU10		
SU12		
}	4822 276 12455	Push Switch, Tact
SU27		

REF. DESIG.	PART NO.	DESCRIPTION	REF. DESIG.	PART NO.	DESCRIPTION
VU01	4822 130 90857	Display Unit FIP10BGM8	▲ R417	4822 116 52892	100Ω ±5% ¼W
XU01	4822 242 72194	Ceramic Vibrator 4.19MHz	▲ R418	4822 116 52892	100Ω ±5% ¼W
			R713		68Ω ±5% 1/6W
			R714		68Ω ±5% 1/6W
			R719	4822 100 11386	1KΩ, Trimming
			R720	4822 100 11386	1KΩ, Trimming
			R725		
			}		
			R730		68Ω ±5% 1/6W
DU51	4822 130 33305	Diode 1SS176, etc.	▲ R731	4822 116 60246	220Ω ±5% 1W
QU51	4822 130 42594	Transistor, Digital DTC144ES	▲ R732	4822 116 60246	220Ω ±5% 1W
QU52	4822 130 42682	Transistor, Digital DTA144ES	R733		
			}		
			R736		10Ω ±5% 1/6W
			▲ R737	4822 116 82049	0.18Ω×2 ±10% 3W
			▲ R738	4822 116 82049	0.18Ω×2 ±10% 3W
			R739		68Ω ±5% 1/6W
			R740		68Ω ±5% 1/6W
CL08	4822 122 32486	Ceramic 0.01μF +80% -20% (SR60L)	R743	4822 111 90726	10Ω ±5% 2W
CL10	4822 122 32486	Ceramic 0.01μF +80% -20% (SR60L)	R744	4822 111 90726	10Ω ±5% 2W
CN05	4822 122 32486	Ceramic 0.01μF +80% -20%	▲ R745	4822 116 82523	4.7KΩ ±5% 1W
CV01			R801	4822 116 82524	27Ω ±5% ¼W, Fusible
}					(SR50L)
CV06	4822 122 32486	Ceramic 0.01μF +80% -20%	▲ R803	4822 116 60331	1KΩ ±5% 1W
CV09			▲ R804	4822 116 82525	390Ω ±5% ¼W, Fusible
}					(SR60L)
CV11	4822 122 32486	Ceramic 0.01μF +80% -20%		4822 116 81316	470Ω ±5% ¼W, Fusible
C419	4822 122 32486	Ceramic 0.01μF +80% -20%	▲ R807	4822 116 60306	1Ω ±5% ¼W, Fusible
C705	4822 122 32917	Ceramic 33pF ±5%		4822 116 60307	1Ω ±5% ¼W, Fusible
C706	4822 122 32917	Ceramic 33pF ±5%			(SR60L)
C711	4822 126 10797	Ceramic 10pF ±0.5pF	▲ R810	4822 116 60306	1Ω ±5% ¼W, Fusible
C712	4822 126 10797	Ceramic 10pF ±0.5pF		4822 116 60307	1Ω ±5% ¼W, Fusible
C713	4822 122 40367	Ceramic 7pF ±0.5pF			(SR50L)
C714	4822 122 40367	Ceramic 7pF ±0.5pF			
C717	4822 122 32895	Ceramic 100pF ±5%			
C718	4822 122 32895	Ceramic 100pF ±5%			
C719	4822 122 32895	Ceramic 100pF ±5%			
C720	4822 122 32895	Ceramic 100pF ±5%			
C727			DL01	4822 130 33305	Diode 1SS176, etc. (SR60L)
C728			DL02	4822 130 33305	Diode 1SS176, etc. (SR60L)
C729	4822 122 32486	Ceramic 0.01μF +80% -20%	DL03	4822 130 33305	Diode 1SS176, etc. (SR60L)
C801	4822 122 32486	Ceramic 0.01μF +80% -20%	DN01	4822 130 80837	Diode HSS81TD
C802	4822 122 32486	Ceramic 0.01μF +80% -20%	DN02	4822 130 80837	Diode HSS81TD
C811	4822 122 30043	Ceramic 0.01μF +80% -20%	DN03	4822 130 33305	Diode 1SS176, etc.
▲ C812	4822 124 41603	Elect 8200μF 56V (SR60L)	D701	4822 130 80273	Zener RD8.2JB2/MTZJ8.2C
▲ C813	4822 124 41603	Elect 4700μF 50V (SR50L)	D702	4822 130 80322	Zener RD15JB3/MTZJ15A
	4822 124 41603	Elect 8200μF 56V (SR60L)	D703		
		Elect 4700μF 50V (SR50L)	}	4822 130 33305	Diode 1SS176, etc.
			D706		
			▲ D801	4822 130 80839	Diode S5688G
			▲ D803	4822 130 80839	Diode S5688G
			▲ D805	4822 130 80839	Diode S5688G
			▲ D807	4822 130 80839	Diode S5688G
			▲ D808	4822 130 80839	Diode S5688G
			▲ D809	4822 130 80839	Diode S5688G
			▲ D810	4822 130 81287	Zener RD33FB2
			▲ D811	4822 130 80319	Zener RD9.1JB2/MTZJ9.1C
			▲ D812	4822 130 81093	Diode BR82
			D813	4822 130 33305	Diode 1SS176, etc.
RE19	4822 100 30126	PV04-RESISTORS 10KΩ(C), Variable	D815	4822 130 80839	Diode S5688G
RE20	4822 100 30126	10KΩ(C), Variable	D816	4822 130 80839	Diode S5688G
▲ RN19	4822 116 60332	1KΩ ±5% 2W (SR60L)	D817	4822 130 80091	Zener RD12JB2/MTZJ12C
	4822 116 60272	820Ω ±5% 2W (SR50L)			
RV31	4822 100 30125	100KΩ(W), Variable			

REF. DESIG.	PART NO.	DESCRIPTION
QE01	4822 130 42298	Transistor 2SC536SP, etc.
QE02	4822 130 42298	Transistor 2SC536SP, etc.
QE03	4822 209 73064	IC NJM2068DD
QL01	4822 209 73275	IC TC9214F (SR60L)
QL02	4822 130 42298	Transistor 2SC536SP, etc. (SR60L)
QL03	4822 130 42298	Transistor 2SC536SP, etc. (SR60L)
QL04	4822 130 42594	Transistor, Digital DTC144ES (SR60L)
QN01	4822 130 43223	Transistor 2SC2240(GR, BL)
QN02	4822 130 43233	Transistor 2SC2240(GR, BL)
QN03	4822 130 42951	Transistor 2SA970(GR, BL)
QN04	4822 209 83312	IC TA7317P
QV01	4822 209 72748	IC LC7821
QV02	4822 209 73275	IC TC9214P
QV03	4822 209 73287	IC LB1630
Q401	4822 209 83631	IC NJM4558DD
Q701	4822 130 42951	Transistor 2SA970(GR, BL)
Q702	4822 130 42951	Transistor 2SA970(GR, BL)
Q703	4822 130 43233	Transistor 2SC2240(GR, BL)
Q704	4822 130 43233	Transistor 2SC2240(GR, BL)
Q705	4822 130 60117	Transistor 2SC3419(Y)
Q706	4822 130 60117	Transistor 2SC3419(Y)
▲ Q707	4822 130 62335	Transistor 2SD2033(E)
▲ Q708	4822 130 62335	Transistor 2SD2033(E)
▲ Q709	4822 130 62334	Transistor 2SB1353(E)
▲ Q710	4822 130 62334	Transistor 2SB1353(E)
▲ Q711	4822 130 61747	Transistor 2SC3182(R, O) (SR60L)
	4822 130 60697	Transistor 2SC3180(R, O) (SR50L)
▲ Q712	4822 130 61747	Transistor 2SC3182(R, O) (SR60L)
	4822 130 60697	Transistor 2SC3180(R, O) (SR50L)
▲ Q713	4822 130 61746	Transistor 2SA1265(R, O) (SR60L)
	4822 130 60694	Transistor 2SA1263N(R, O) (SR50L)
▲ Q714	4822 130 61746	Transistor 2SA1265(R, O) (SR60L)
	4822 130 60694	Transistor 2SA1263N(R, O) (SR50L)
Q715	4822 130 42298	Transistor 2SC536SP, etc.
Q716	4822 130 42298	Transistor 2SC536SP, etc.
Q717	4822 209 83732	IC AN7062P
Q718	4822 130 42594	Transistor, Digital DTC144ES
Q719	4822 130 42682	Transistor, Digital DTA144ES
▲ Q801	4822 209 60826	IC NJM7812FA
▲ Q802	4822 209 61533	IC NJM7806FA
Q804	4822 130 42298	Transistor 2SC536SP, etc.
Q805	4822 130 42298	Transistor 2SC536SP, etc.
Q806	4822 130 42682	Transistor, Digital DTA144ES
PV04-MISCELLANEOUS		
JL01	4822 265 30627	Terminal, 3P RCA (SR60L)
JL02	4822 267 31208	Terminal, 2P RCA (SR60L)
JV01	4822 265 30397	Terminal, 4P RCA
JV02	4822 265 30397	Terminal, 4P RCA
JV03	4822 265 30457	Terminal, 6P RCA
JV04	4822 266 30274	Terminal, 2P RCA
J401	4822 267 30741	Terminal, 2P RCA

REF. DESIG.	PART NO.	DESCRIPTION
LN01	4822 280 70354	Relay
L701	4822 157 51739	Coil, Speaker
L702	4822 157 51739	Coil, Speaker
SE01	4822 276 12926	Push Switch, Bass EQ
PW04-SPEAKER TERMINAL CIRCUIT BOARD		
CW01	4822 122 32486	Ceramic Cap. 0.01 μ F +80% -20%
CW04		
JW01	4822 290 60686	Terminal, Speaker
P104-FRONT-END/IF BLOCK CIRCUIT BOARD		
P104-CAPACITORS		
CA01	4822 125 50384	Trimming 20pF
CA02	4822 122 40491	Ceramic 0.022 μ F +80% -20%
CA03		Ceramic 15pF \pm 5%
CA04	4822 122 31205	Ceramic 47pF \pm 5%
CA05	4822 121 41629	Film 390pF \pm 5%
CA06	4822 122 32486	Ceramic 0.01 μ F +80% -20%
CA07	4822 122 32486	Ceramic 0.01 μ F +80% -20%
CA08	4822 125 50384	Trimming 20pF
CA09		Ceramic 15pF \pm 5%
CA11	4822 122 40568	Ceramic 68pF \pm 5%
CA12	4822 122 10367	Ceramic 150pF \pm 5%
CA13	4822 122 32486	Ceramic 0.01 μ F +80% -20%
CA14	4822 122 32486	Ceramic 0.01 μ F +80% -20%
CA15	4822 122 32486	Ceramic 0.01 μ F +80% -20%
CA16	4822 122 40491	Ceramic 0.022 μ F +80% -20%
CA19	4822 122 32486	Ceramic 0.01 μ F +80% -20%
CA20	4822 122 40491	Ceramic 0.022 μ F +80% -20%
CA22	4822 122 32486	Ceramic 0.01 μ F +80% -20%
CA24	4822 122 32486	Ceramic 0.01 μ F +80% -20%
C201	4822 122 40491	Ceramic 0.01 μ F +80% -20%
C202	4822 122 40491	Ceramic 0.01 μ F +80% -20%
C203	4822 122 40491	Ceramic 0.022 μ F +80% -20%
C204	4822 122 40491	Ceramic 0.022 μ F +80% -20%
C206	4822 122 40491	Ceramic 0.022 μ F +80% -20%
C211	4822 122 40491	Ceramic 0.022 μ F +80% -20%
C226	4822 122 40491	Ceramic 0.022 μ F +80% -20%
C310	4822 121 41623	Film 1000pF \pm 5%
P104-RESISTORS		
RA13	4822 100 11352	22K Ω , Trimming
▲ R210	4822 116 52846	150 Ω \pm 5% $\frac{1}{4}$ W
R211	4822 100 11471	100K Ω , Trimming
R301	4822 100 11351	10K Ω , Trimming
P104-SEMICONDUCTORS		
DA01	4822 125 50416	Varicap SVC342
DA02	4822 130 33305	Diode 1SS176, etc.
DA03	4822 125 50416	Varicap SVC342
DA04	4822 130 33305	Diode 1SS176, etc.
QA01	4822 130 42298	Transistor 2SC536SP, etc.
QA02	4822 130 42298	Transistor 2SC536SP, etc.
QA03	4822 130 42298	Transistor 2SC536SP, etc.

REF. DESIG.	PART NO.	DESCRIPTION
Q201	4822 209 71785	IC LA1266
Q202	4822 130 42082	Transistor 2SC1047(C)
P104-MISCELLANEOUS		
A101	4822 210 10372	V.H.F. Tuner, FE415-G09
FA01	4822 242 71509	Ceramic Filter
F201	4822 242 71135	Ceramic Filter, SFE10.7MS3-A
F202	4822 242 71135	Ceramic Filter, SFE10.7MS3-A
J101	4822 266 30298	Terminal, Antenna
LA01	4822 157 52328	Ant Coil, MW
LA02	4822 157 52716	OSC Coil, MW
LA03	4822 157 52714	Ant Coil, LW
LA04	4822 157 52717	OSC Coil, LW
LA05	4822 157 53589	Choke Coil, 39mH
L201	4822 148 81096	I.F.T. Coil, FM DET
P304-MPX/PLL BLOCK CIRCUIT BOARD		
P304-CAPACITORS		
CA15	4822 122 32486	Ceramic 0.01 μ F +80% -20%
CA21	4822 122 40568	Ceramic 68pF \pm 5%
C210	4822 122 40568	Ceramic 68pF \pm 5%
C310	4822 121 41623	Film 1000pF \pm 5%
C501	4822 122 31205	Ceramic 47pF \pm 5%
C502	4822 122 31205	Ceramic 47pF \pm 5%
C504	4822 122 32486	Ceramic 0.01 μ F +80% -20%
C507	4822 122 32486	Ceramic 0.01 μ F +80% -20%
C508	4822 122 32486	Ceramic 0.01 μ F +80% -20%
C509	4822 122 40491	Ceramic 0.022 μ F +80% -20%
P304-RESISTORS		
▲ R311	4822 116 52849	220 Ω \pm 5% $\frac{1}{4}$ W
R314	4822 100 11351	10K Ω , Trimming
▲ R514	4822 116 52849	220 Ω \pm 5% $\frac{1}{4}$ W
P304-SEMICONDUCTORS		
D301	4822 130 33305	Diode 1SS176, etc.
D501	4822 130 80317	Zener RD5.1JB2/MTZJ5.1B
QA04	4822 130 42682	Transistor, Digital DTA144ES
QA05	4822 130 42682	Transistor, Digital DTA144ES
QA06	4822 130 42682	Transistor, Digital DTA144ES
Q204	4822 130 42682	Transistor, Digital DTA144ES
Q301	4822 209 71776	IC TEA5581
Q501	4822 209 62557	IC LM7000N
Q503	4822 130 42298	Transistor 2SC536SP, etc.
Q504	4822 130 42298	Transistor 2SC536SP, etc.
P304-MISCELLANEOUS		
X501	4822 242 72333	Crystal, 7.2MHz
P904-POWER SW./B-UP TRANSF. CIRCUIT BOARD		
▲ C901	4822 122 33276	Ceramic Cap. 0.01 μ F \pm 20%
▲ F901	4822 253 20145	Fuse T1.25A 250V (SR60L)
	4822 253 30201	Fuse 1.0A 250V (SR50L)
▲ S901	4822 276 12924	Push Switch, Power (SR60L)
	4822 276 12925	Push Switch, Power (SR50L)

NOTE ON SAFETY:

Symbol ▲ Fire or electrical shock hazard. Only original parts should be used to replace any part marked with symbol ▲. Any other component substitution (other than original type), may increase risk of fire or electrical shock hazard.