

# Service Manual

SR6005 /N1SG/N1B/U1B/K1B

AV Surround Receiver

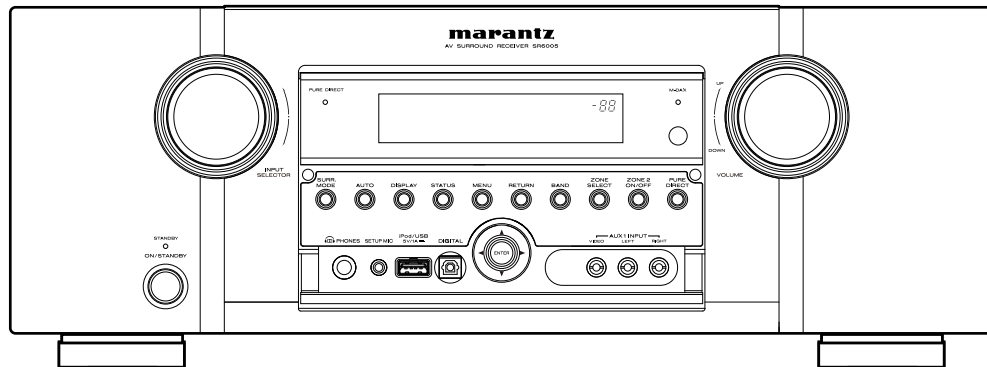

SR6005

• For purposes of improvement, specifications and design are subject to change without notice.

• Please use this service manual with referring to the operating instructions without fail.

• Some illustrations using in this service manual are slightly different from the actual set.

# marantz®

## SR6005

Ver. 2

Please refer to the  
MODIFICATION NOTICE.

## MARANTZ DESIGN AND SERVICE

Using superior design and selected high grade components, **MARANTZ** company has created the ultimate in stereo sound. Only original **MARANTZ** parts can insure that your **MARANTZ** product will continue to perform to the specifications for which it is famous.

Parts for your **MARANTZ** equipment are generally available to our National Marantz Subsidiary or Agent.

### ORDERING PARTS :

Parts can be ordered either by mail or by Fax.. In both cases, the correct part number has to be specified.

The following information must be supplied to eliminate delays in processing your order :

1. Complete address
2. Complete part numbers and quantities required
3. Description of parts
4. Model number for which part is required
5. Way of shipment
6. Signature : any order form or Fax. must be signed, otherwise such part order will be considered as null and void.

#### USA

**MARANTZ AMERICA, INC**  
100 CORPORATE DRIVE  
MAHWAH, NEW JERSEY 07430  
USA

#### EUROPE / TRADING

**D&M EUROPE B. V.**  
P. O. BOX 8744, BUILDING SILVERPOINT  
BEEMDSTRAAT 11, 5653 MA EINDHOVEN  
THE NETHERLANDS  
PHONE : +31 - 40 - 2507844  
FAX : +31 - 40 - 2507860

#### CANADA

**D&M Canada Inc.**  
5-505 APPLE CREEK BLVD.  
MARKHAM, ONTARIO L3R 5B1  
CANADA  
PHONE : 905 - 415 - 9292  
FAX : 905 - 475 - 4159

#### JAPAN

**D&M Holdings Inc.**  
D&M BUILDING, 2-1 NISSHIN-CHO,  
KAWASAKI-KU, KAWASAKI-SHI,  
KANAGAWA, 210-8569 JAPAN

株式会社 ディーアンドエムホールディングス

本 社 〒210-8569  
神奈川県川崎市川崎区日進町2-1 D&Mビル

#### KOREA

**D&M SALES AND MARKETING KOREA LTD.**  
2F, YEON BLDG.,  
88-5, BANPO-DONG, SEOCHO-GU,  
SEOUL KOREA  
PHONE : +82 - 2 - 715 - 9041  
FAX : +82 - 2 - 715 - 9040

#### CHINA

**D&M SALES AND MARKETING SHANGHAI LTD.**  
ROOM.808 SHANGHAI AIRPORT CITY TERMINAL  
NO.1600 NANJING (WEST) ROAD, SHANGHAI,  
CHINA. 200040  
TEL : 021 - 6248 - 5151  
FAX : 021 - 6248 - 4434

### NOTE ON SAFETY :

Symbol  $\triangle$  Fire or electrical shock hazard. Only original parts should be used to replaced any part marked with symbol  $\triangle$ .

Any other component substitution (other than original type), may increase risk of fire or electrical shock hazard.

### 安全上の注意 :

$\triangle$ がついている部品は、安全上重要な部品です。必ず指定されている部品番号の部品を使用して下さい。

### SHOCK, FIRE HAZARD SERVICE TEST :

**CAUTION** : After servicing this appliance and prior to returning to customer, measure the resistance between either primary AC cord connector pins (with unit NOT connected to AC mains and its Power switch ON), and the face or Front Panel of product and controls and chassis bottom.

Any resistance measurement less than 1 Megohms should cause unit to be repaired or corrected before AC power is applied, and verified before it is return to the user/customer.

Ref. UL Standard No. 60065.

In case of difficulties, do not hesitate to contact the Technical Department at above mentioned address.

091105DM/DG

## SAFETY PRECAUTIONS

The following check should be performed for the continued protection of the customer and service technician.

### LEAKAGE CURRENT CHECK

Before returning the unit to the customer, make sure you make either (1) a leakage current check or (2) a line to chassis resistance check. If the leakage current exceeds 0.5 milliamps, or if the resistance from chassis to either side of the power cord is less than 460 kohms, the unit is defective.

Be sure to test for leakage current with the AC plug in both polarities, in addition, in each power ON, OFF and STANDBY mode, if applicable.

### **CAUTION** Please heed the points listed below during servicing and inspection.

#### ⊙ Heed the cautions!

Spots requiring particular attention when servicing, such as the cabinet, parts, chassis, etc., have cautions indicated on labels. Be sure to heed these cautions and the cautions indicated in the handling instructions.

#### ⊙ Caution concerning electric shock!

- (1) An AC voltage is impressed on this set, so touching internal metal parts when the set is energized could cause electric shock. Take care to avoid electric shock, by for example using an isolating transformer and gloves when servicing while the set is energized, unplugging the power cord when replacing parts, etc.
- (2) There are high voltage parts inside. Handle with extra care when the set is energized.

#### ⊙ Caution concerning disassembly and assembly!

Through great care is taken when manufacturing parts from sheet metal, there may in some rare cases be burrs on the edges of parts which could cause injury if fingers are moved across them. Use gloves to protect your hands.

#### ⊙ Only use designated parts!

The set's parts have specific safety properties (fire resistance, voltage resistance, etc.). For replacement parts, be sure to use parts which have the same properties. In particular, for the important safety parts that are marked  $\triangle$  on wiring diagrams and parts lists, be sure to use the designated parts.

#### ⊙ Be sure to mount parts and arrange the wires as they were originally!

For safety reasons, some parts use tape, tubes or other insulating materials, and some parts are mounted away from the surface of printed circuit boards. Care is also taken with the positions of the wires and clamps are used to keep wires away from heating and high voltage parts, so be sure to set everything back as it was originally.

#### ⊙ Inspect for safety after servicing!

Check that all screws, parts and wires removed or disconnected for servicing have been put back in their original positions, inspect that no parts around the area that has been serviced have been negatively affected, conduct an insulation check on the external metal connectors and between the blades of the power plug, and otherwise check that safety is ensured.

(Insulation check procedure)

Unplug the power cord from the power outlet, disconnect the antenna, plugs, etc., and turn the power switch on. Using a 500V insulation resistance tester, check that the inplug and the externally exposed metal parts (antenna terminal, headphones terminal, input terminal, etc.) is 1M $\Omega$  or greater. If it is less, the set must be inspected and repaired.

### **CAUTION** Concerning important safety parts

Many of the electric and structural parts used in the set have special safety properties. In most cases these properties are difficult to distinguish by sight, and using replacement parts with higher ratings (rated power and withstand voltage) does not necessarily guarantee that safety performance will be preserved. Parts with safety properties are indicated as shown below on the wiring diagrams and parts lists in this service manual. Be sure to replace them with parts with the designated part number.

(1) Schematic diagrams ..... Indicated by the  $\triangle$  mark.

(2) Parts lists ..... Indicated by the  $\triangle$  mark.

Using parts other than the designated parts could result in electric shock, fires or other dangerous situations.

# NOTE FOR SCHEMATIC DIAGRAM

**WARNING:**

Parts marked with this symbol  $\triangle$  have critical characteristics. Use ONLY replacement parts recommended by the manufacturer.

**CAUTION:**

Before returning the unit to the customer, make sure you make either (1) a leakage current check or (2) a line to chassis resistance check. If the leakage current exceeds 0.5 milliamps, or if the resistance from chassis to either side of the power cord is less than 460 kohms, the unit is defective.

**WARNING:**

DO NOT return the unit to the customer until the problem is located and corrected.

**NOTICE:**

ALL RESISTANCE VALUES IN OHM. k=1,000 OHM / M=1,000,000 OHM

ALL CAPACITANCE VALUES IN MICRO FARAD. P=MICRO-MICRO FARAD EACH VOLTAGE AND CURRENT ARE MEASURED AT NO SIGNAL INPUT CONDITION. CIRCUIT AND PARTS ARE SUBJECT TO CHANGE WITHOUT PRIOR NOTICE.

# NOTE FOR PARTS LIST

1. Parts for which "nsp" is indicated on this table cannot be supplied.
  2. When ordering of part, clearly indicate "1" and "1" (i) to avoid mis-supplying.
  3. Ordering part without stating its part number can not be supplied.
  4. Part indicated with the mark "★" is not illustrated in the exploded view.
  5. Not including General-purpose Carbon Film Resistor in the P.W.Board parts list. (Refer to the Schematic Diagram for those parts.)
  6. Not including General-purpose Carbon Chip Resistor in the P.W.Board parts list. (Refer to the Schematic Diagram for those parts.)
- WARNING:** Parts marked with this symbol  $\triangle$  have critical characteristics. Use ONLY replacement parts recommended by the manufacturer.

● Resistors

Ex.:      RN      14K      2E      182      G      FR

Type      Shape and performance      Power      Resistance      Allowable error      Others

RD : Carbon	2B : 1/8 W	F : ±1%	P : Pulse-resistant type
RC : Composition	2E : 1/4 W	G : ±2%	NL : Low noise type
RS : Metal oxide film	2H : 1/2 W	J : ±5%	NB : Non-burning type
RW: winding	3A : 1 W	K : ±10%	FR : Fuse-resistor
RN : Metal film	3D : 2 W	M : ±20%	F : Lead wire forming
RK : Metal mixture	3F : 3 W		
	3H : 5 W		

\* Resistance

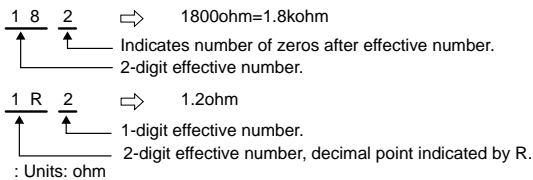

● Capacitors

Ex.:      CE      04W      1H      3R2      M      BP

Type      Shape and performance      Dielectric strength      Capacity      Allowable error      Others

CE : Aluminum foil electrolytic	0J : 6.3 V	F : ±1%	HS : High stability type
CA : Aluminium solid electrolytic	1A : 10 V	G : ±2%	BP : Non-polar type
CS : Tantalum electrolytic	1C : 16 V	J : ±5%	HR : Ripple-resistant type
CQ : Film	1E : 25 V	K : ±10%	DL : For change and discharge
CK : Ceramic	1V : 35 V	M : ±20%	HF : For assuring high frequency
CC : Ceramic	1H : 50 V	Z : ±80%	U : UL part
CP : Oil	2A : 100 V	- : -20%	C : CSA part
CM : Mica	2B : 125 V	P : +100%	W : UL-CSA part
CF : Metallized	2C : 160 V	C : ±0.25pF	F : Lead wire forming
CH : Metallized	2D : 200 V	D : ±0.5pF	
	2E : 250 V	= : Others	
	2H : 500 V		
	2J : 630 V		

\* Capacity (electrolyte only)



\* Capacity (except electrolyte)

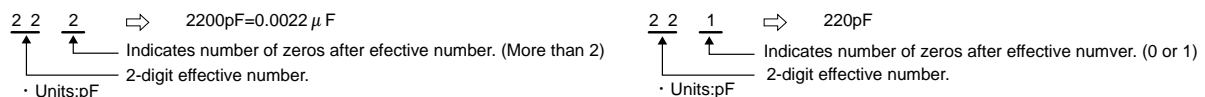

· When the dielectric strength is indicated in AC,"AC" is included after the dielectric strength value.

# TECHNICAL SPECIFICATIONS

## Audio Section

### Power amplifier

#### Rated output :

Front :

110 W + 110 W (8 Ω, 20 Hz – 20 kHz with 0.08 % T.H.D.)  
190 W + 190 W (6 Ω, 1 kHz with 10 % T.H.D.)

Center :

110 W (8 Ω, 20 Hz – 20 kHz with 0.08 % T.H.D.)  
190 W (6 Ω, 1 kHz with 10 % T.H.D.)

Surround :

110 W + 110 W (8 Ω, 20 Hz – 20 kHz with 0.08 % T.H.D.)  
190 W + 190 W (6 Ω, 1 kHz with 10 % T.H.D.)

Surround Back :

110 W + 110 W (8 Ω, 20 Hz – 20 kHz with 0.08 % T.H.D.)  
190 W + 190 W (6 Ω, 1 kHz with 10 % T.H.D.)

**Output connectors :** 6 – 8 Ω (SPEAKER A + B : 8 Ω)

### Analog

**Input sensitivity/Input impedance :** 175 mV/50 kΩ

**Frequency response :** 10 Hz – 100 kHz — ±3 dB (Source Direct mode)

**S/N :** 98 dB (IHF-A weighted, Source Direct mode)

## Video Section

### Standard video connectors

**Input/output level and impedance :** 1 V<sub>p-p</sub>, 75 Ω

**Frequency response :** 5 Hz – 10 MHz — +1, -3 dB

### Standard video connectors

**Input/output level and impedance :**

Y (brightness) signal — 1 V<sub>p-p</sub>, 75 Ω

P<sub>B</sub> / C<sub>B</sub> signal — 0.7 V<sub>p-p</sub>, 75 Ω

P<sub>R</sub> / C<sub>R</sub> signal — 0.7 V<sub>p-p</sub>, 75 Ω

**Frequency response :** 5 Hz – 60 MHz — +0, -3 dB

## Tuner section

[FM] (Note: μV at 75 Ω, 0 dBf = 1 × 10<sup>-15</sup> W)

**Receiving Range (for U) :**

[FM] 87.5 MHz – 107.9 MHz

[AM] 520 kHz – 1710 kHz

**Receiving Range (for N,K) :**

[FM] 87.5 MHz – 108.0 MHz

[AM] 522 kHz – 1611 kHz

**Usable Sensitivity :**

[FM] 1.2 μV (12.8 dBf)

[AM] 18 μV

**50 dB Quieting Sensitivity (for U) :**

[FM] MONO 2.8 μV (20.2 dBf)

**50 dB Quieting Sensitivity (for N,K) :**

[FM] MONO 2.0 μV (17.3 dBf)

STEREO 42 μV (34.5 dBf)

**S/N (IHF-A) :**

[FM] MONO 70 dB

STEREO 67 dB

**Total harmonic Distortion (at 1 kHz) (for U) :**

[FM] MONO 0.7 %

STEREO 1.0 %

**Total harmonic Distortion (at 1 kHz) (for N,K) :**

[FM] MONO 0.3 %

STEREO 0.7 %

## General

**Power supply (for U) :** AC 120 V, 60 Hz

**Power supply (for K) :** AC 220 V, 50 Hz

**Power supply (for N) :** AC 230 V, 50 Hz

**Power consumption :**

650 W

0.2 W (Standby)

3 W (CEC standby)

**Maximum external dimensions :**

440 (W) x 161 (H) x 389 (D) mm

**Weight :** 11.8 kg

## Remote Control Unit (RC011SR)

**Batteries :** R03/AAA Type (two batteries)

## DIMENSION

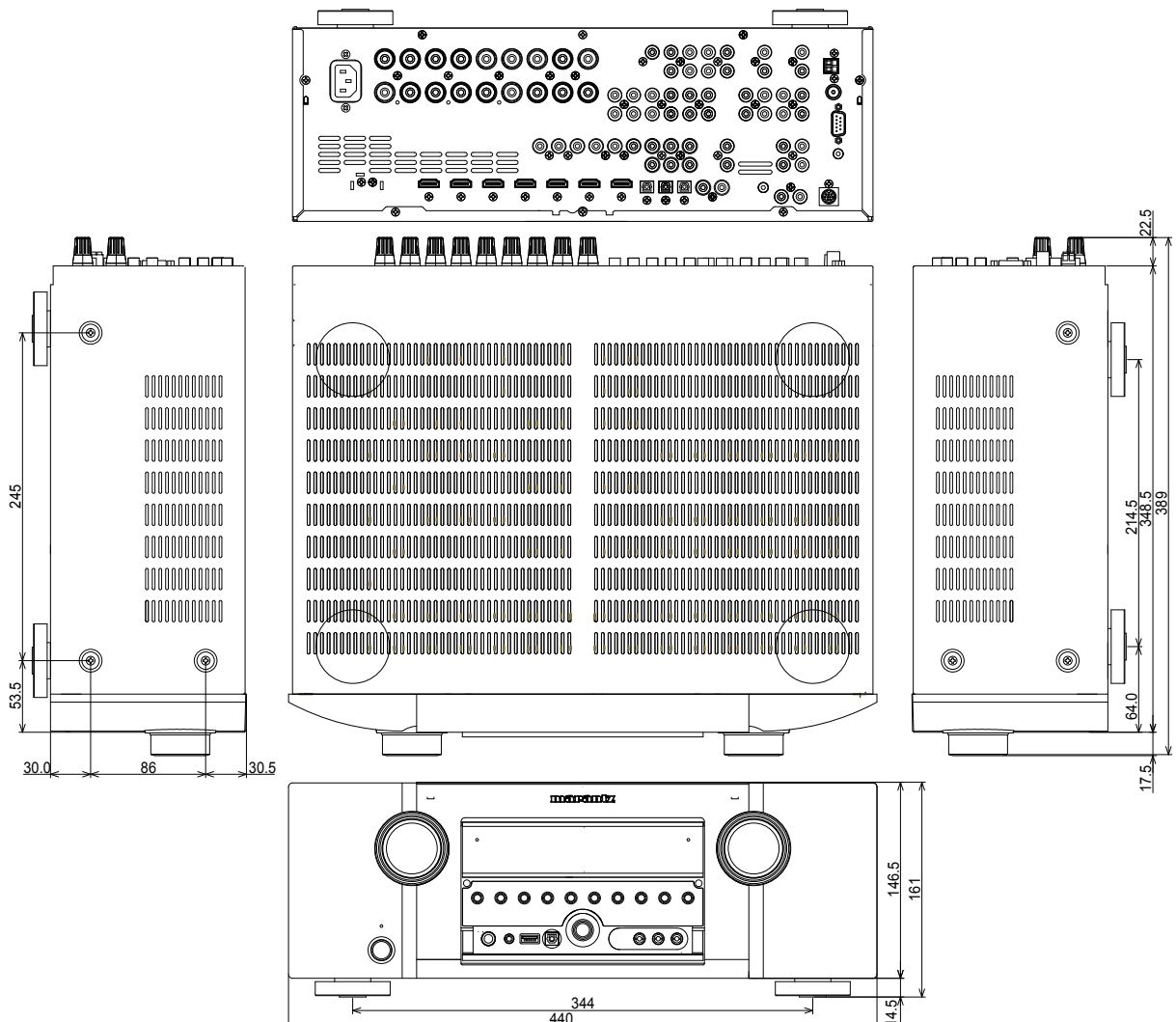

# CAUTION IN SERVICING

## Initializing AV SURROUND RECEIVER

AV SURROUND RECEIVER initialization should be performed when the  $\mu$ com, peripheral parts of  $\mu$ com, and Digital P.W.B. are replaced.

1. Turn off the power using ON/STANDBY button.
2. Press ON/STANDBY button while simultaneously pressing SURR.MODE and AUTO buttons.
3. Check that the entire display is flashing with an interval of about 1 second, and release your fingers from the 2 buttons and the microprocessor will be initialized.

**Note:**

- If step 3 does not work, start over from step 1.
- All user settings will be lost and this factory setting will be recovered when this initialization mode. So make sure to memorize your setting for restoring after the initialization.

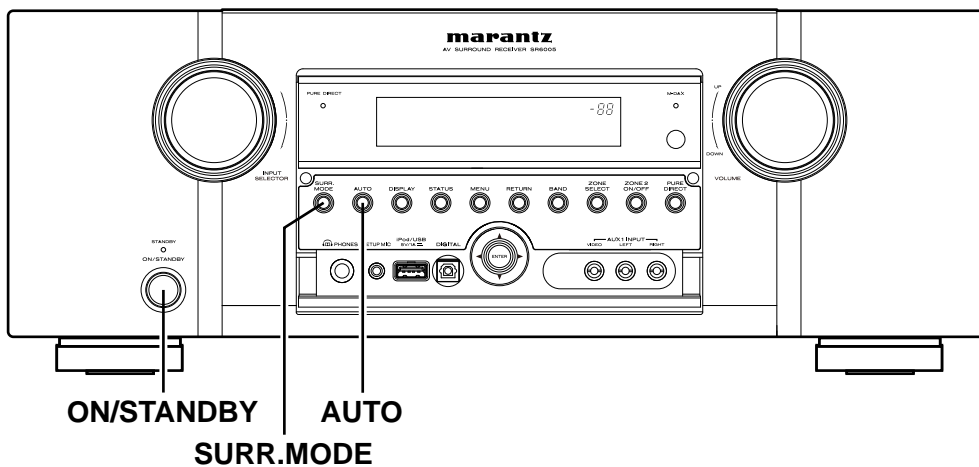

## Service Jigs

When you repair the printing board, you can use the following JIG (Extension cable kit). Please order to marantz Official Service Distributor in your region if necessary.

8U-110084S : EXTENSION UNIT KIT : 1 Set  
(Refer to "JIG FOR SERVICING".)

# DISASSEMBLY

- Disassemble in order of the arrow of the figure of following flow.
- In the case of the re-assembling, assemble it in order of the reverse of the following flow.
- In the case of the re-assembling, observe "attention of assembling" it.
- If wire bundles are untied or moved to perform adjustment or parts replacement etc., be sure to rearrange them neatly as they were originally bundled or placed afterward.  
Otherwise, incorrect arrangement can be a cause of noise generation.

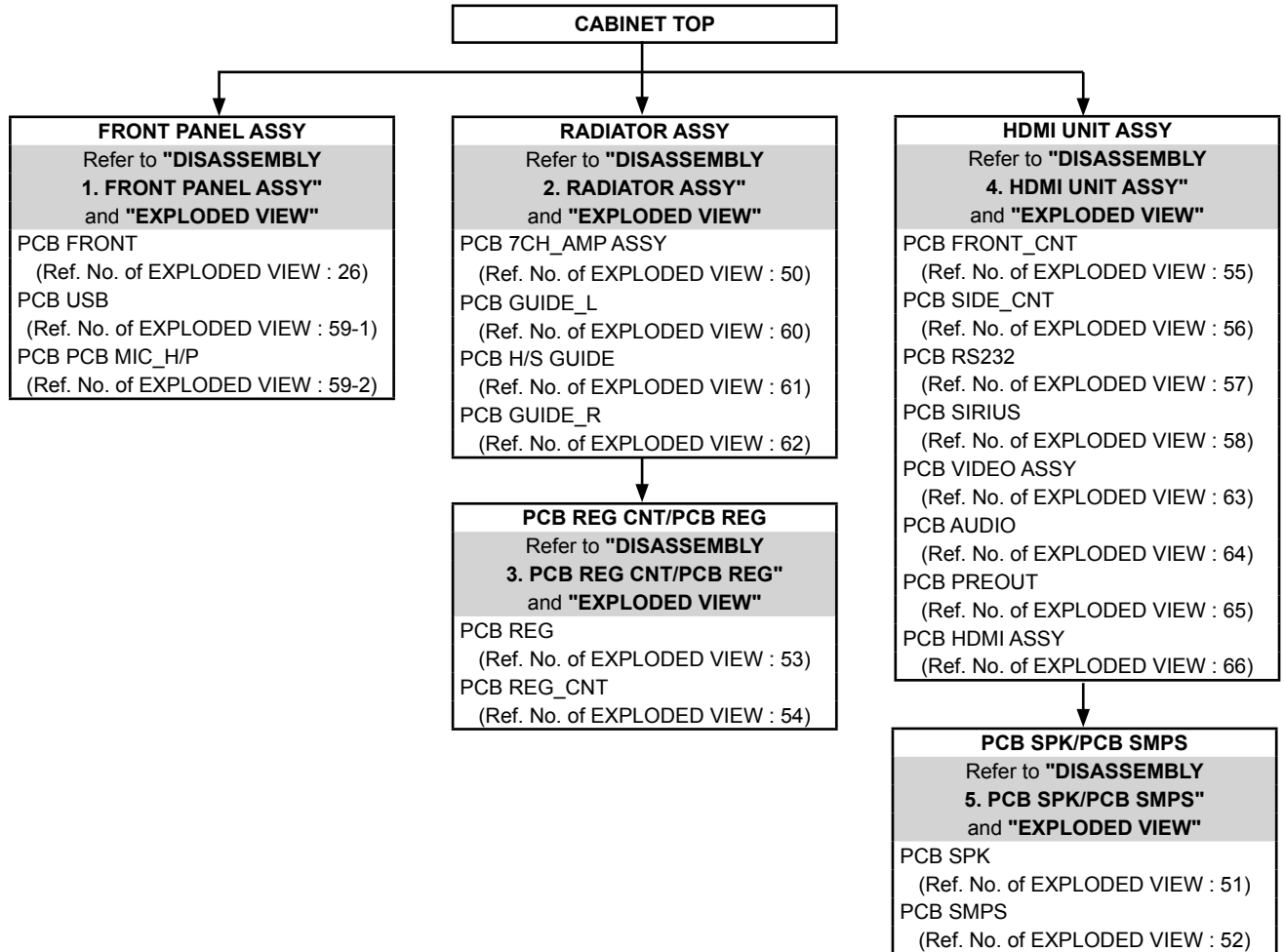

## About the photos used for descriptions in the "DISASSEMBLY" section.

- The direction from which the photographs used herein were photographed is indicated at "Direction of photograph: \*\*\*\*" at the left of the respective photographs.
- Refer to the table below for a description of the direction in which the photos were taken.
- Photographs for which no direction is indicated were taken from above the product.
- The Photographs is SR6005 N1B model.

### The viewpoint of each photograph (Photografy direction)

[View from above]

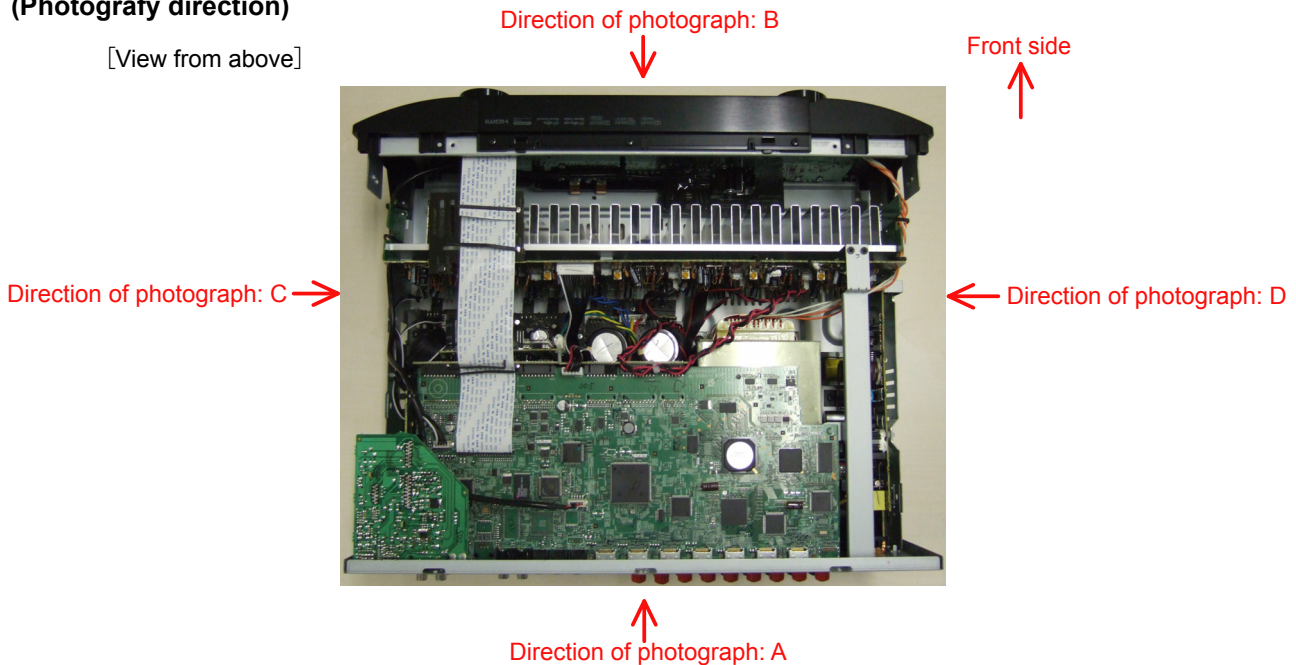

## 1. FRONT PANEL ASSY

Proceeding : **CABINET TOP** → **FRONT PANEL ASSY**

- (1) Remove the screws.

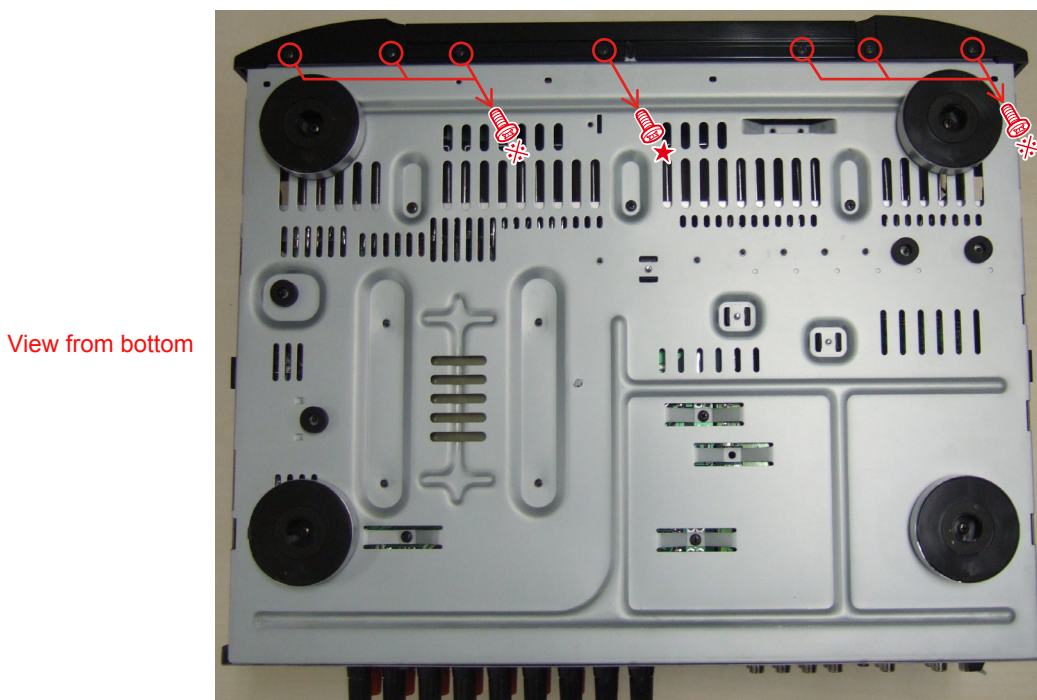



(2) Disconnect the connector wires then remove the screws.

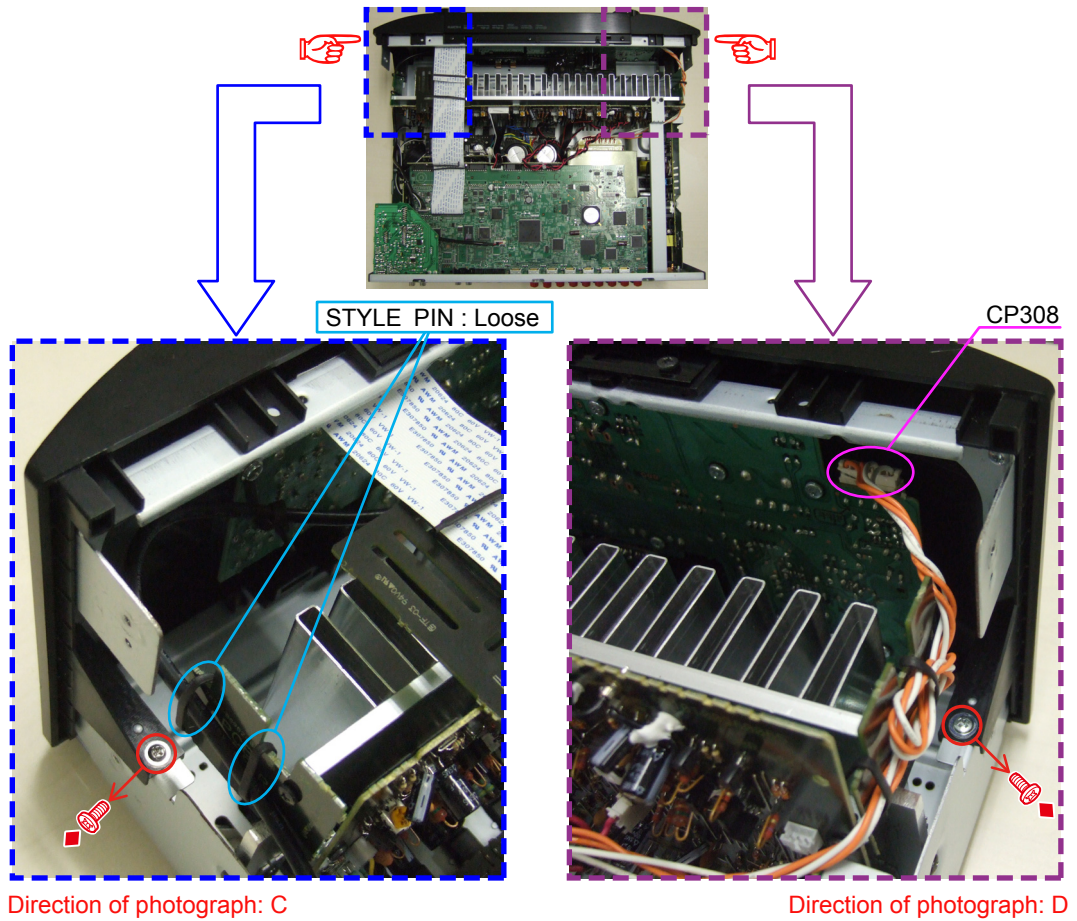

(3) Disconnect the connector wires and FFC cable.

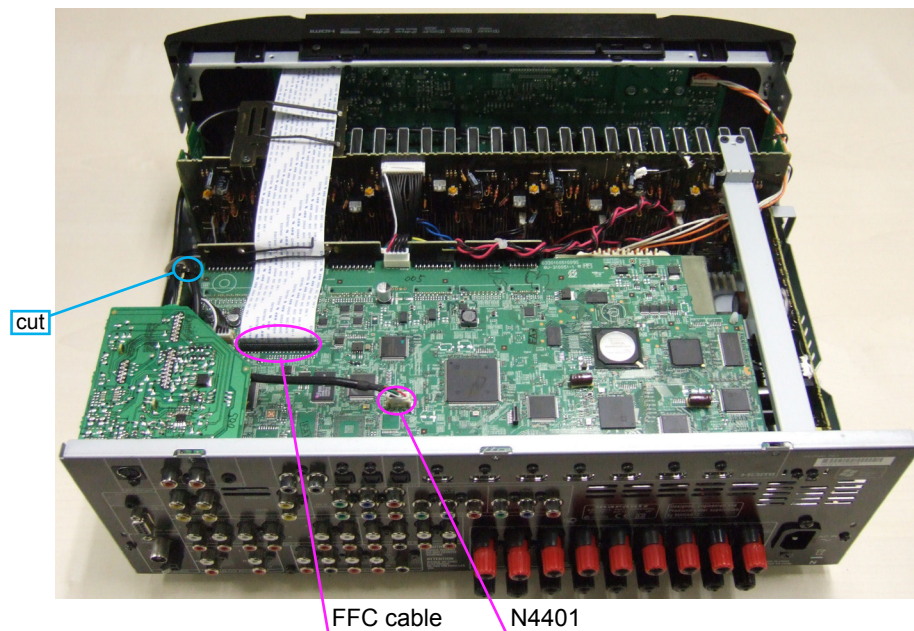

Please refer to "EXPLODED VIEW" for the disassembly method of each PCB included in FRONT PANEL ASSY.

## 2. RADIATOR ASSY

Proceeding : **CABINET TOP** → **FRONT PANEL ASSY** → **RADIATOR ASSY**

(1) Remove the screws.

View from bottom



(2) Cut the wire clamp bands, then remove the screws.

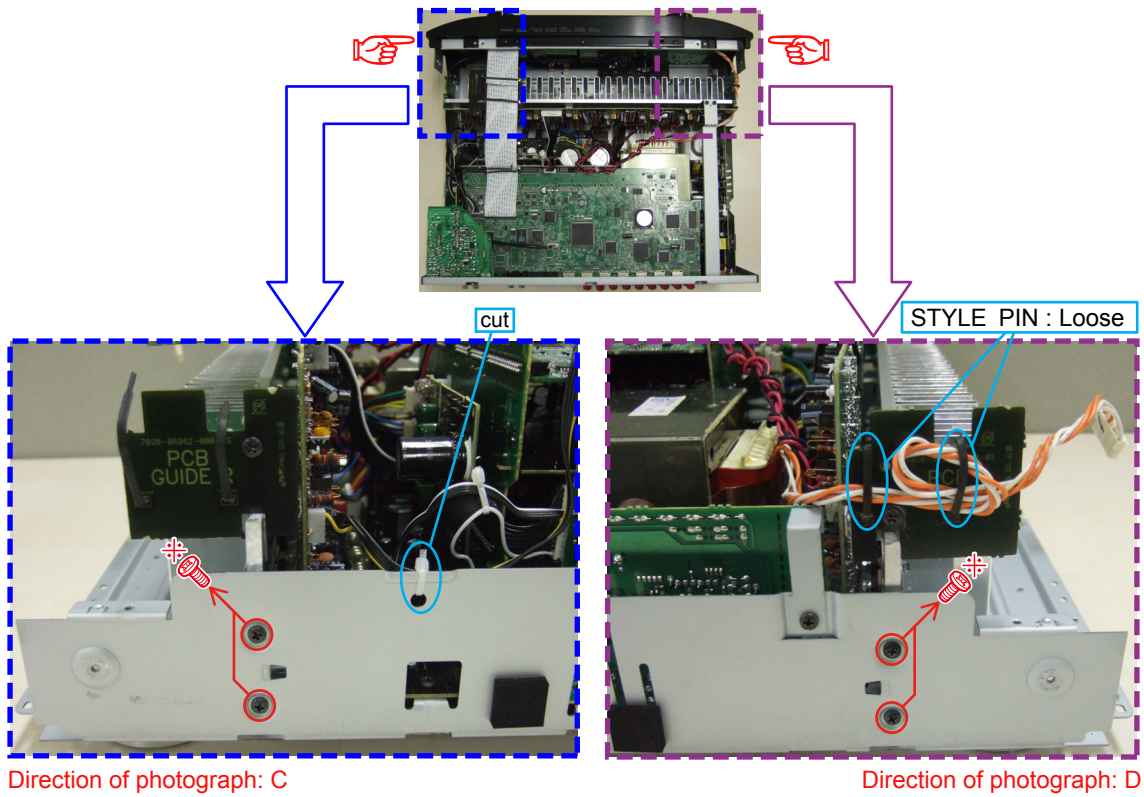

(3) Disconnect the connector wires.

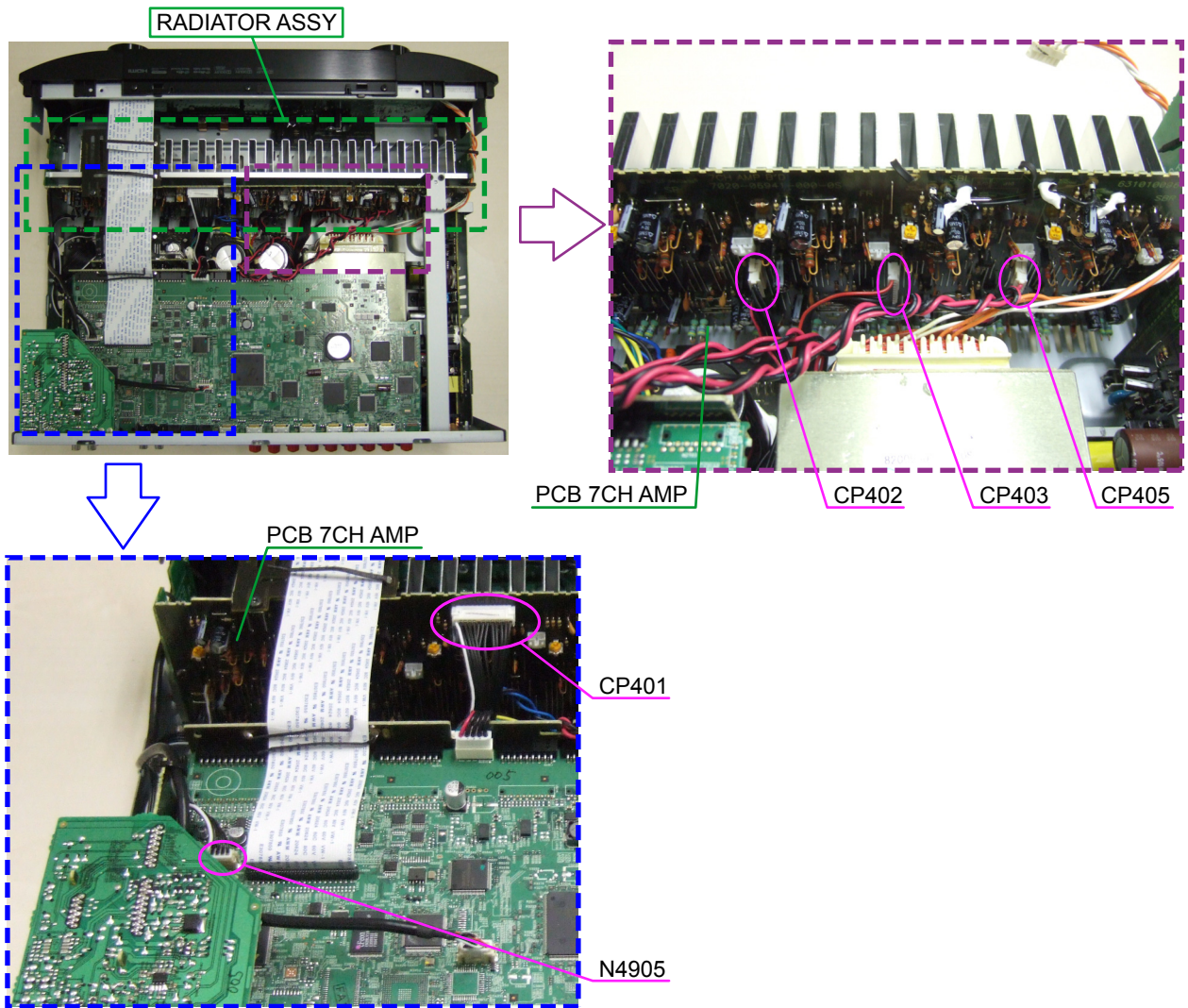

Please refer to "EXPLODED VIEW" for the disassembly method of each PCB included in RADIATOR ASSY.

### 3. PCB REG CNT/PCB REG

Proceeding : **CABINET TOP** → **FRONT PANEL ASSY** → **RADIATOR ASSY**  
→ **PCB REG CNT/PCB REG**

(1) Remove the screws.

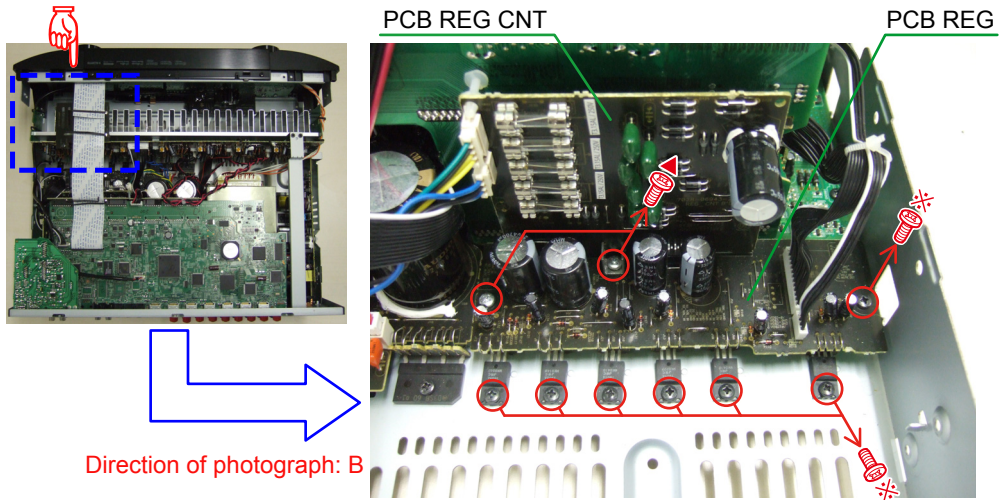

(2) Disconnect the connector wires and connector board.

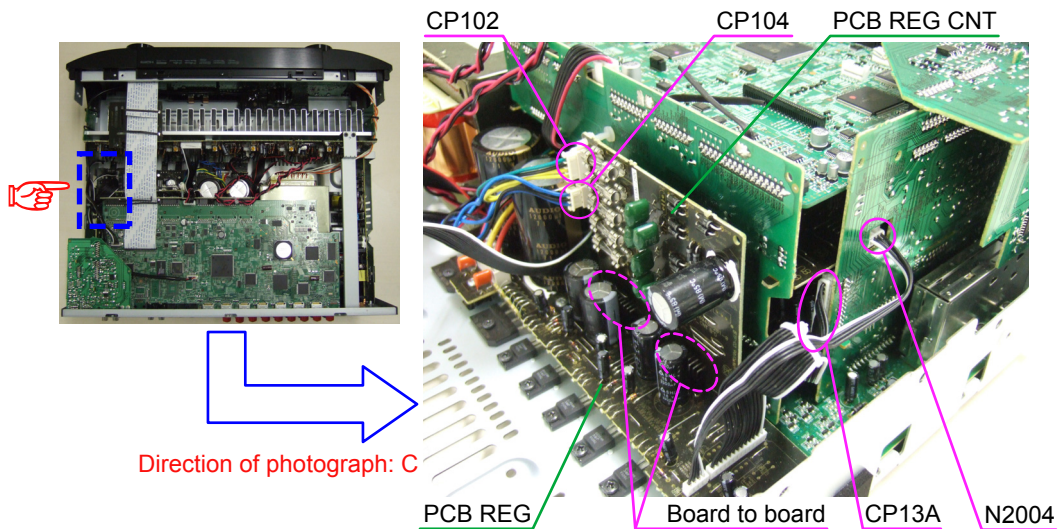

#### 4. HDMI UNIT ASSY

Proceeding : **CABINET TOP** → **HDMI UNIT ASSY**

(1) Cut the wire clamp bands, then disconnect the connector wire and FFC cable.

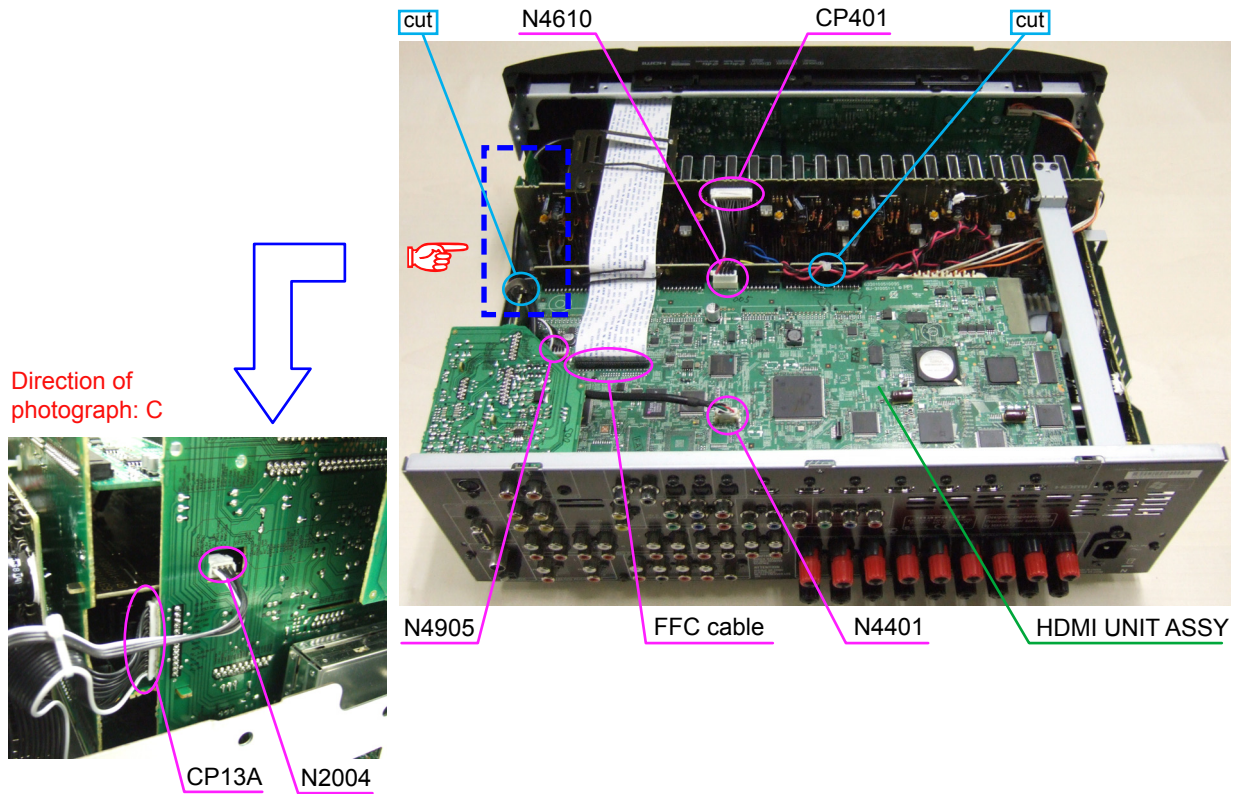

(2) Remove the screws, then remove the BACK PANEL.

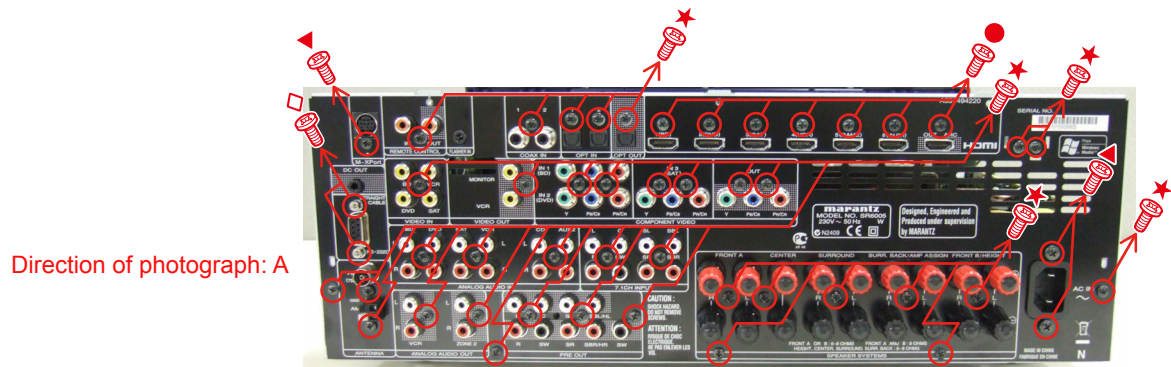

- (3) Remove the screws and the SUPPORTER PCB.  
Remove the PCB SIRIUS and the PCB RS232 from the PCB SIDE CNT(Board to board).

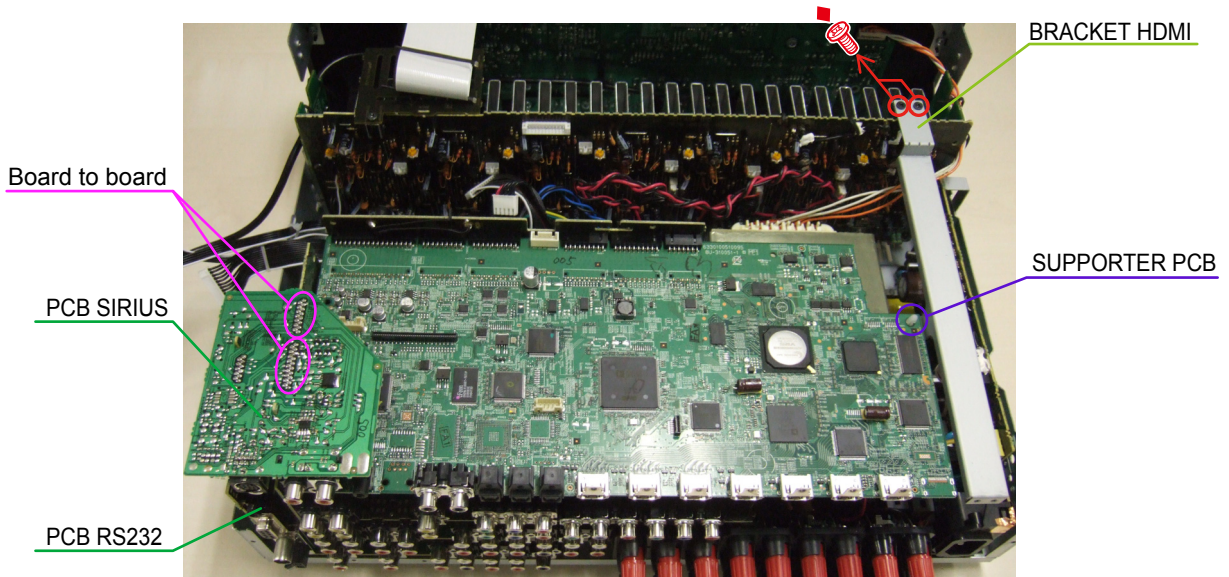

- (4) Disconnect the connector board.

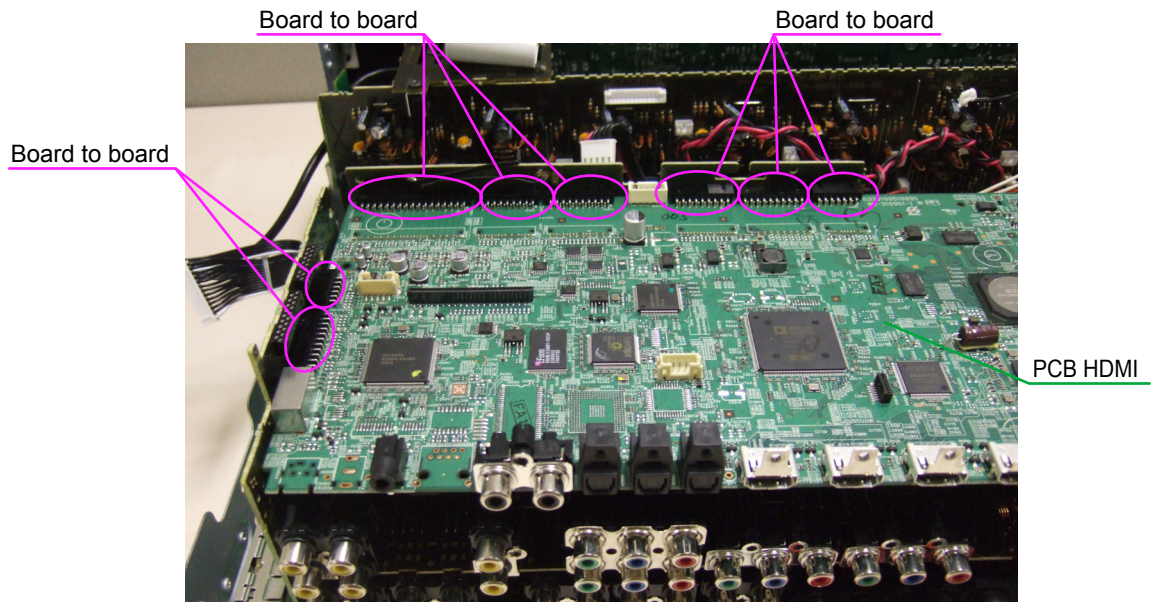

- (5) Disconnect the connector board.

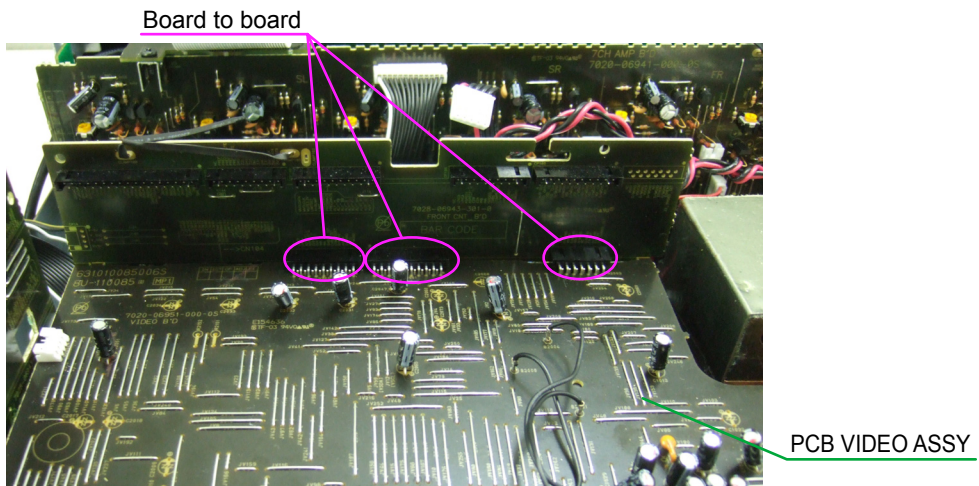

(6) Remove the screws then disconnect the connector.

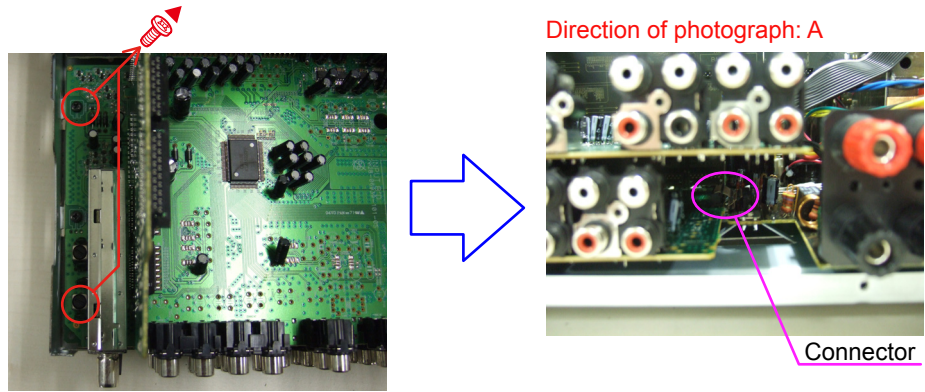

(7) Disconnect the connector board.

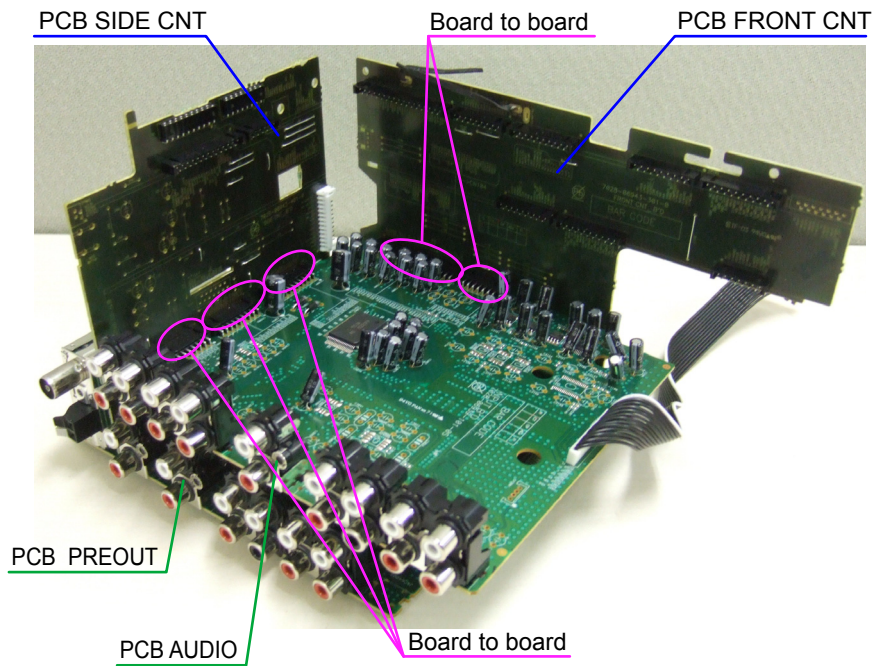

Please refer to "EXPLODED VIEW" for the disassembly method of each PCB included in HDMI UNIT ASSY.

## 5. PCB SPK/PCB SMPS

Proceeding : **CABINET TOP** → **HDMI UNIT ASSY** → **PCB SPK/PCB SMPS**

(1) Remove the screws and SUPPORTER P.C.

View from bottom

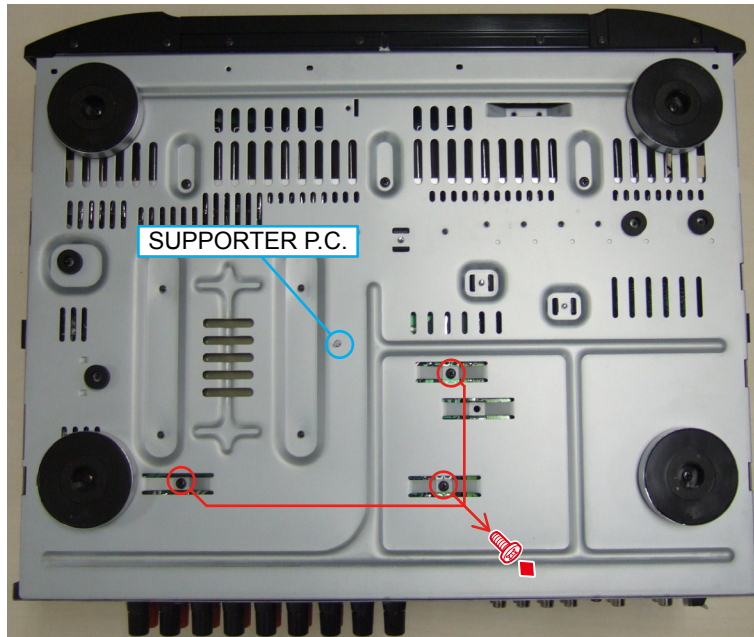

(2) Disconnect the connector wire, then remove the screws and SUPPORTER P.C.

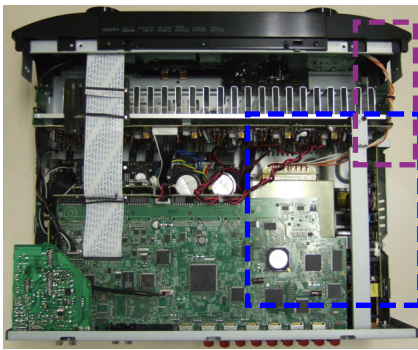

Direction of photograph: D

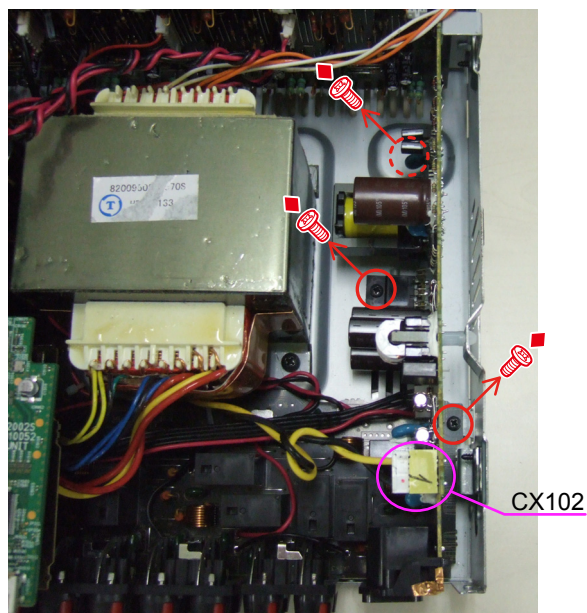
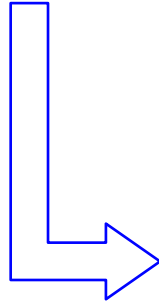
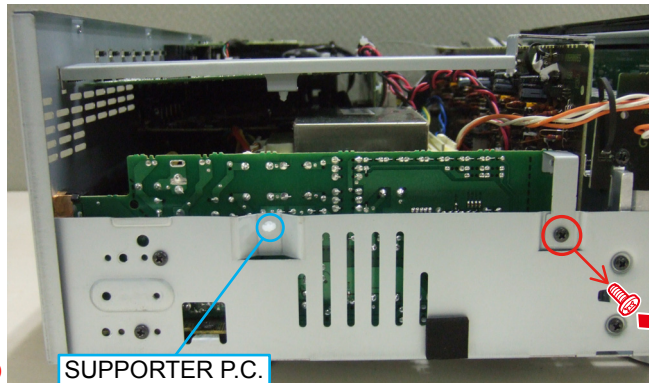



(3) Disconnect the connector wire, then remove the screws. Remove the PCB SPK and the PCB SMPS from the main unit.

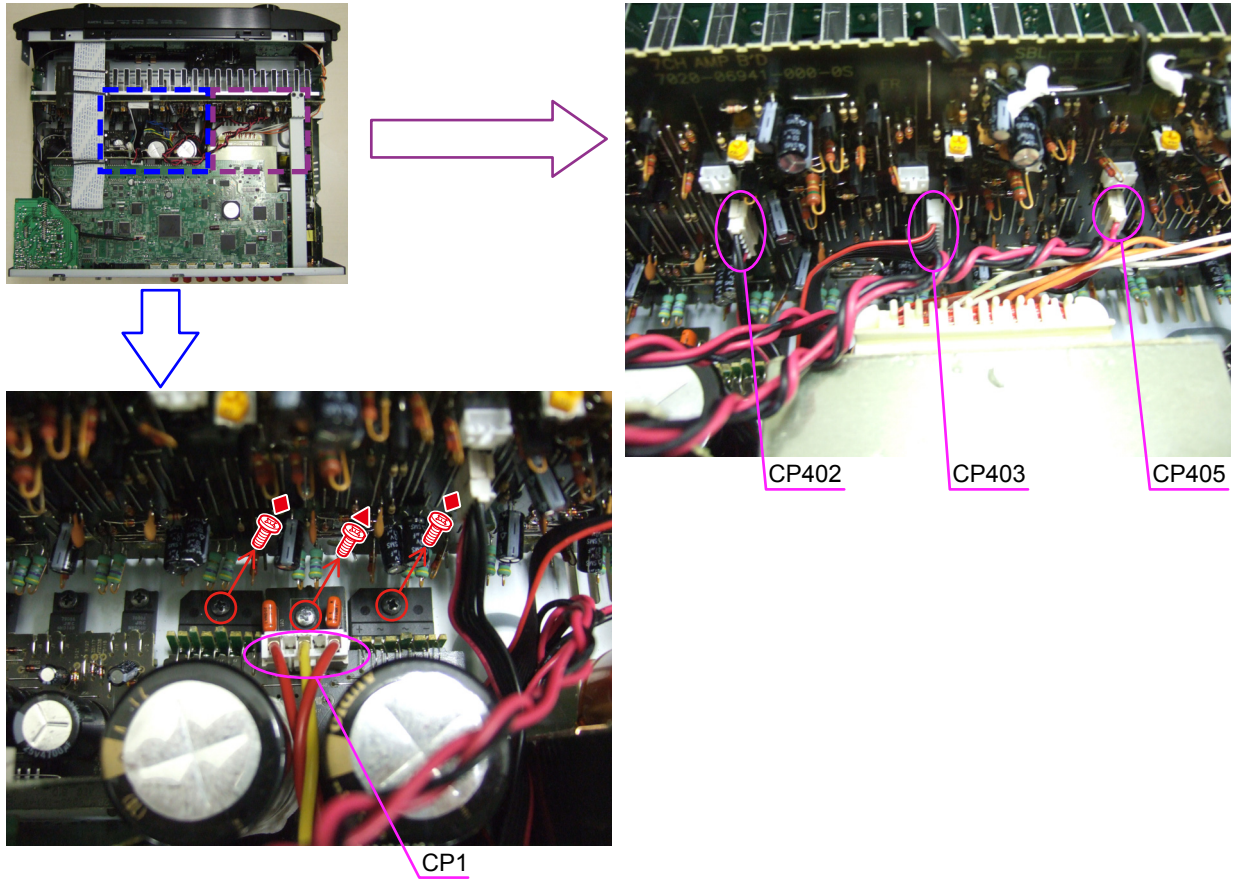

(4) Disconnect the connector board.

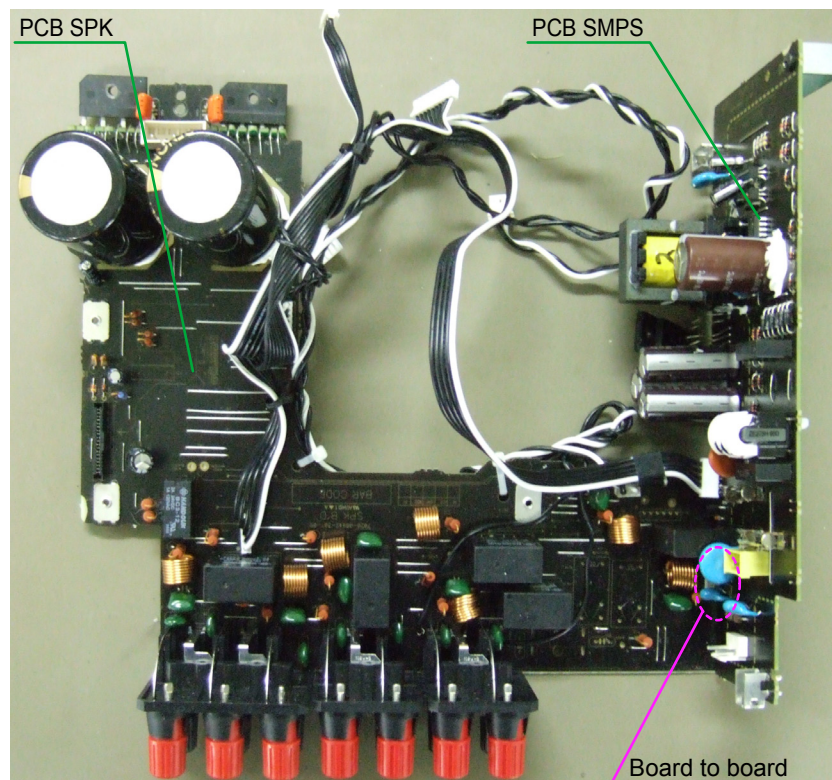

# SPECIAL MODE

## Special mode setting button

※ Press the ON/STANDBY button to turn on while pressing both buttons A and B at the same time.

Mode	Button A	Button B	Contents
µcom/DSP Version display mode	STATUS	RETURN	Firmware versions such as Main, Sub, DSP are displayed in the FL manager. Errors are displayed when they occur. (Refer to 19 page.)
Errors checking mode (Displaying the protection history)	STATUS	CURSOR ◀	Displaying the protection history (Refer to 21 page.)
Initialization mode	SURR. MODE	AUTO	Backup data initialization is carried out. (Refer to 6 page.)
Panel lock mode	AUTO	ENTER	Operations using main unit panel buttons or master volume are rejected.
Panel lock mode (Remove Master volume)	AUTO	CURSOR ▶	Operations using main unit panel buttons are rejected.
Cancellation of panel lock mode	AUTO	RETURN	Panel lock mode is cancelled.

※ When power is turned on, pressing both buttons A and B at the same time for 3 seconds or more.

Mode	Button A	Button B	Contents
Mode for preventing remote control acceptance	CURSOR ◀	MENU	Operations using remote control are rejected. Select with the CURSOR ◀ ▶ button.
DUAL BACKUP MEMORY (Backup)	BAND	ENTER	Backup of DUAL BACKUP MEMORY is performed. (Refer to 23 page.)
DUAL BACKUP MEMORY (Recovery)	BAND	MENU	Recovery of DUAL BACKUP MEMORY is performed. (Refer to 23 page.)
DUAL BACKUP MEMORY (Backup Clear)	BAND	AUTO	Backup of DUAL BACKUP MEMORY is cleared. (Refer to 23 page.)

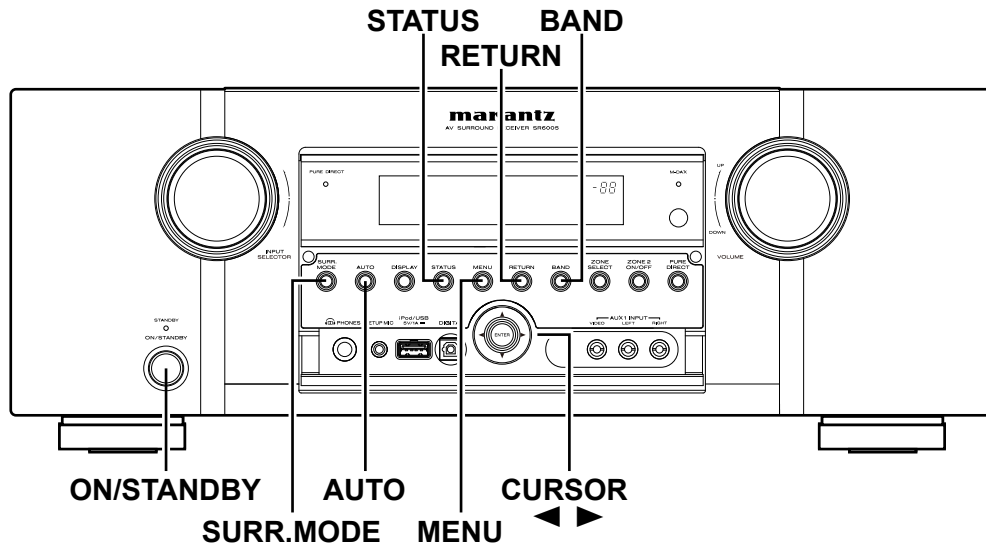

# 1. $\mu$ com/DSP Version display mode

## 1.1. Operation specifications

### $\mu$ com/DSP version display mode:

When started up, the version information is displayed.

#### Starting up:

With the "STATUS" and "RETURN" buttons pressed, press the "ON/STANDBY" button to turn the power on. Now, press the "STATUS" button to the display the 2nd item information on the FL Display.

## 1.2. Display Order

Error information(Refer to 1.3. Error display) → ①Model destination information → ②Main  $\mu$ -com/ROM version → ③Main 1st Boot Loader → ④Sub  $\mu$ -com/Sub FBL → ⑤DSP version → ⑥Audio PLD → ⑦OSD FPGA Config → ⑧OSD Program → ⑨OSD font data → ⑩HD RADIO SDK/HD RADIO BBP (SR6005 U only) → ⑪USB Version

### ①Model destination information :

Upper	S	R	6	0	0	5		N								
Lower	S	/	N	.			*	*	*	*	*	*	*	*	*	*

### ②Main $\mu$ -com & ROM version :

Upper		M	a	i	n					:	*	*	.	*	*
Lower		M	a	i	n		R	O	M	:	*	*	.	*	*

### ③Main 1st Boot Loader :

Upper		M	a	i	n		F	B	L		:	*	*	.	*	*
Lower																

### ④Sub $\mu$ -com & Sub FBL :

Upper		S	u	b						:	*	*	.	*	*
Lower		S	u	b		F	B	L		:	*	*	.	*	*

### ⑤DSP ROM :

Upper		D	S	P						:	*	*	.	*	*	
Lower																

### ⑥Audio PLD :

Upper	A	u	d	i	o		F	L	D		:	*	*	.	*	*
Lower																

### ⑦OSD FPGA Config :

Upper	O	S	D		C	o	n	f	i	s	:					
Lower	*	*	*	*	*	*	*	*	*	*	*	*	*	*	*	*

### ⑧OSD Program :

Upper	O	S	D		R	P	G	:								
Lower	*	*	*	*	*	*	*	*	*	*	*	*	*	*	*	*

### ⑨OSD font data :

Upper	O	S	D		D	A	T	:								
Lower	*	*	*	*	*	*	*	*	*	*	*	*	*	*	*	*

⑩ HD RADIO SDK/HD RADIO BBP (SR6005 U only):

Upper	*	H	D	S	D	K	:				*	*	.	*	*	
Lower	*	H	D	B	B	P	:	C	0	0	0	2	.	0	0	0

⑪ USB Version :

Upper		U	S	B						:	*	*	.	*	*
Lower															

1.3. Error display

See the following table for each "Error information" display and its contents (status).

Display order is ①,②,③,④,⑤,⑥.

Condition	State	State
① Sub-μcom NG	No response from Sub-μcom	SUB ERROR 01
② DIR NG	No response from DIR	DIR ERROR 01
③ DSP NG	When DSP boot, executing DSP reset makes no change to DSP1 FLAG0 port "H".	DSP ERROR 01
	No change to DSP FLAG0 port "H" before issuing DSP command.	DSP ERROR 02
	When DSP data read, executing WRITE="L" makes no change to ACK="H".	DSP ERROR 03
	When DSP data read, executing REQ="L" makes no change to ACK="L".	DSP ERROR 04
	When DSP data write, executing WRITE="H" makes no change to ACK="H".	DSP ERROR 05
	When DSP data write, executing REQ="L" makes no change to ACK="L".	DSP ERROR 06
	When DSP special code boot, executing DSP reset makes no change to DSP FLAG0 port "H".	DSP ERROR 11
	No change to DSP FLAG0 port "H" before issuing DSP special read command.	DSP ERROR 12
	No change to DSP FLAG0 port "H" before DSP version read.	DSP ERROR 13
④ EEPROM NG	Error appeared in EEPROM checksum.(*** is a block address number.)	E2PROM ERR***
⑤ USB NG	No response from USB μ-com.	USB ERROR 01
⑥ Both SUB/DSP /EEPROM OK		(No error display, version display only)

## 2. Errors checking mode (Displaying the protection history)

### 2.1. Operation specifications

#### Error mode (Displaying the protection history):

When started up, the error information is displayed.

#### Starting up:

##### ●All model commonness

With the "STATUS" and "CURSOR ◀" buttons pressed, press the "ON/STANDBY" button to turn the power on. The error (protection history display) mode is set.

Now, press the "STATUS" button to turn on the FL display.

### 2.2. About the display on the FL display

When the "STATUS" button is pressed after setting the error (protection history display) mode, a history like the one shown below is displayed, depending on the conditions.

(1) Normally (when there has been no protection incident)

Upper	P	R	O	T	E	C	T		H	I	S	T	O	R	Y	
Lower	:	N	O		P	R	O	T	E	C	T					

(2) For ASO (when the last protection incident was ASO protection)

Upper	P	R	O	T	E	C	T		H	I	S	T	O	R	Y	
Lower	:	A	S	O												

**Cause:** The line between speaker terminals is shorted, or use speakers having impedance less than that specified.

**Supplementary information:** As the excess current is detected after operation of the speaker relay, the shorted speaker terminal and the connected speaker can be identified.

Turning on the power without correcting the abnormality will cause the protection function to work about 5 seconds later and the power supply will be shut off.

(3) For DC (when the last protection incident was DC protection)

Upper	P	R	O	T	E	C	T		H	I	S	T	O	R	Y	
Lower	:	D	C													

**Cause:** DC output of the power amplifier is abnormal.

Turning on the power without correcting the abnormality will cause the protection function to work about 5 seconds later and the power supply will be shut off.

(4) For THERMAL (when the last protection incident was THERMAL protection)

Upper	P	R	O	T	E	C	T		H	I	S	T	O	R	Y	
Lower	:	T	H	E	R	M	A	L								

**Cause:** The temperature of the heat sink is excessive.

Turning on the power without correcting the abnormality will cause the protection function to work about 5 seconds later and the power supply will be shut off.

\* Additional causes of protection can be due to loose connections, associated components, Microprocessor, etc.

When the "STATUS" button is pressed again after the above protection history is displayed, the normal display reappears.

### 2.3. Clearing the protection history

There are two ways to clear the protection history, as described below.

- (1) Start up the error (protection display) mode, display the error, then press and hold in the "ENTER" button for 3 seconds.

Upper	P	R	O	T	E	C	T		H	I	S	T	O	R	Y
Lower	:	T	H	E	R	M	A	L							



Press and hold in the "ENTER" button for 3 seconds.

Upper	P	R	O	T	E	C	T		H	I	S	T	O	R	Y
Lower					C	L	E	A	R						



The above is displayed and the protection history is cleared.

Upper	P	R	O	T	E	C	T		H	I	S	T	O	R	Y
Lower	:	N	O		P	R	O	T	E	C	T				

- (2) Initialize. (Refer to "Initializing AV SURROUND RECEIVER" 6 page.)

※ If you want to save a backup, use the method in 2.3.(1) above.

#### Warning indication by the POWER LED

If the power is turned off when a protection incident has been detected, the POWER LED (red) flashes as a warning according to the conditions in which the protection incident occurred.

- (1) ASO/DC PROTECTION : Flashes in cycles of 0.5 seconds (0.25 seconds lit, 0.25 seconds off)
- (2) THERMAL PROTECTION : Flashes in cycles of 2 seconds (1 second lit, 1 second off)

### 3. DUAL BACKUP MEMORY

This product has a Dual Backup Memory function. The conventional Backup functions to memorize, in the EEPROM (U5302) in the circuit, a current setting of the moment the main power is turned off so that it can be restored when it is turned ON again. Meanwhile, the DUAL BACKUP MEMORY is capable of memorizing any arbitrary setting that is configured while the product is in operation so as to restore it at any time. When servicing units returned from end-users for repairs, use this function to back up the current setting (e.g. Tuner Preset). This will enable the units to be returned to the users after repairs, with the setting unchanged.

**NOTE :** If end-users use this function, the data will be overwritten.  
 The contents of the memory do not disappear even if you initialize this unit.  
 If you want to erase, please refer to 3.2. SERVICE PRECAUTIONS.

#### 3.1. HOW TO OPERATE

##### -Backup-

- (1) Configure a setting you would like to save in the MEMORY and hold down the "BAND" and "ENTER" buttons on the Front Panel at the same time for 3 seconds or more.
- (2) The FL Display indicates "MEMORY SAVING" while the Backup is being performed.

FLD	M	E	M	O	R	Y	S	A	V	I	N	G				
-----	---	---	---	---	---	---	---	---	---	---	---	---	--	--	--	--

- (3) The FL Display indicates "COMPLETE" when the Backup is completed.

FLD	C	O	M	P	L	E	T	E								
-----	---	---	---	---	---	---	---	---	--	--	--	--	--	--	--	--

##### -Recovery-

- (1) Hold down the "BAND" and "MENU" buttons at the same time for 3 seconds or more.
- (2) The FL Display indicates "MEMORY LOAD" while the Recovery is being performed.

FLD	M	E	M	O	R	Y	L	O	A	D					
-----	---	---	---	---	---	---	---	---	---	---	--	--	--	--	--

- (3) After the FL Display indicates "COMPLETE", the product goes into Standby mode. When the power is restored, the Recovery is completed.

FLD	C	O	M	P	L	E	T	E								
-----	---	---	---	---	---	---	---	---	--	--	--	--	--	--	--	--

The FL Display indicates "NO BACKUP" if the DUAL BACKUP MEMORY has not been activated with no data to be recovered saved in the Memory.

FLD	N	O	B	A	C	K	U	P								
-----	---	---	---	---	---	---	---	---	--	--	--	--	--	--	--	--

#### 3.2. SERVICE PRECAUTIONS

When the Flash Rom (U5302) on the HDMI PWB is replaced make sure, in order to maintain consistency with the Backup Memory, to clear the DUAL BACKUP MEMORY in the following way :

##### -How to clear the Backup Memory-

- (1) Hold down the "BAND" and "AUTO" buttons at the same time for 3 seconds or more.
- (2) The FL Display indicates "BACKUP CLEAR" while the memory is being cleared.

FLD	B	A	C	K	U	P	C	L	E	A	R				
-----	---	---	---	---	---	---	---	---	---	---	---	--	--	--	--

- (3) After the FL Display indicates "COMPLETE", the operation is completed.

FLD	C	O	M	P	L	E	T	E								
-----	---	---	---	---	---	---	---	---	--	--	--	--	--	--	--	--

# JIG FOR SERVICING

When you repair the printing board, you can use the following JIG (Extension cable kit). Please order to marantz Official Service. Distributor in your region if necessary.

**Note: When the connection which is wrong in the JIG (EXTENSION UNIT KIT) is done it becomes cause of damage.**

8U-110084S : EXTENSION UNIT KIT

## • Connection of PCB HDMI JIG

### -Preparation-

- 8U-110084S: EXTENSION UNIT KIT : 1 Set
- Insulation sheet (Do not supply it) : 3 sheet
- Ground lead (Do not supply it) : 3 pcs

### -Procedures-

(1) Remove the screws, then remove the BACK PANEL.

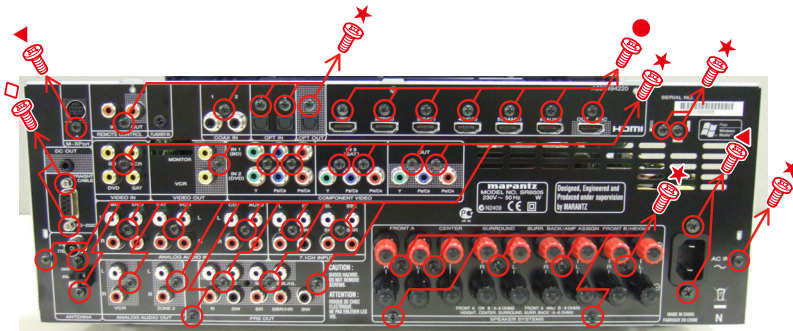

(2) Remove the screws and the SUPPORTER PCB.  
Remove the PCB SIRIUS and the PCB RS232 from the PCB SIDE CNT(Board to board).

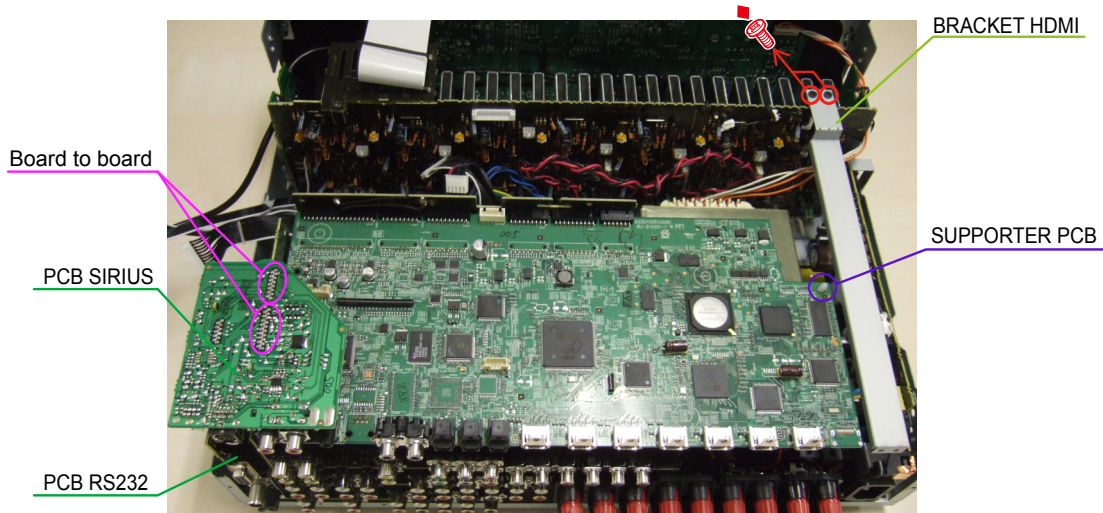

(3) Disconnect the connector board.

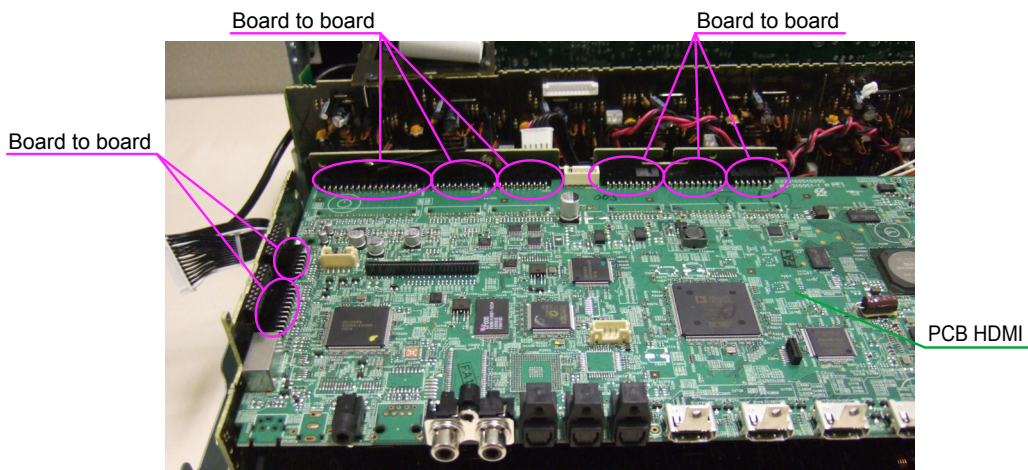



(4) Disconnect the connector board.

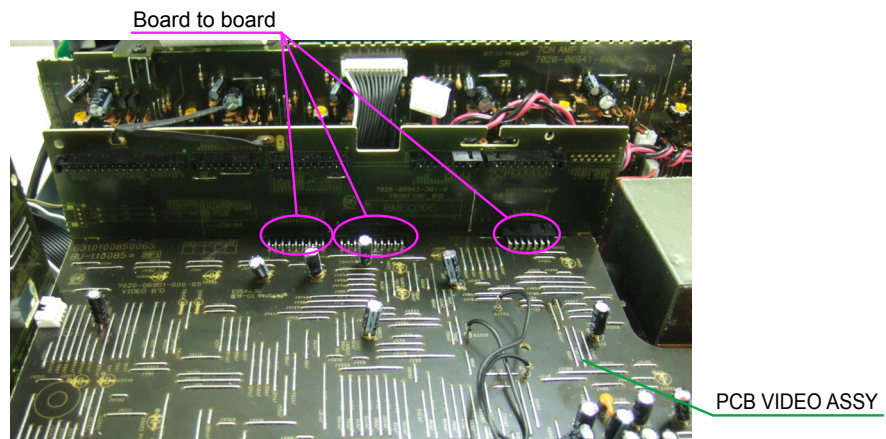

(5) Remove the screws then disconnect the connector.

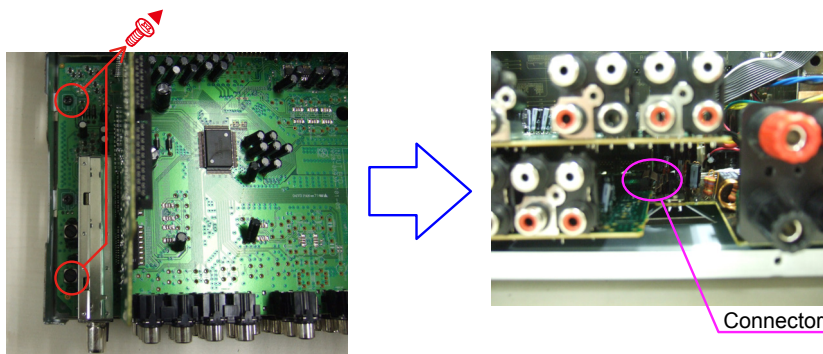

(6) Disconnect the connector board.

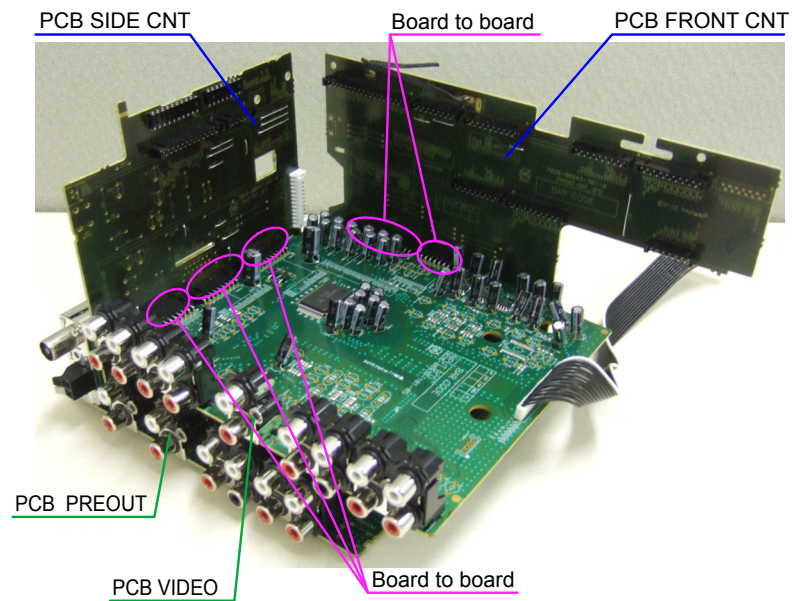

- (3) PCB HDMI is detached from the chassis, and it puts it into the state turned inside out.  
 Please pave an insulation sheet that is larger than PCB HDMI under PCB.  
 ※ Connect the ground point of PCB to the chassis with a ground lead or the like.

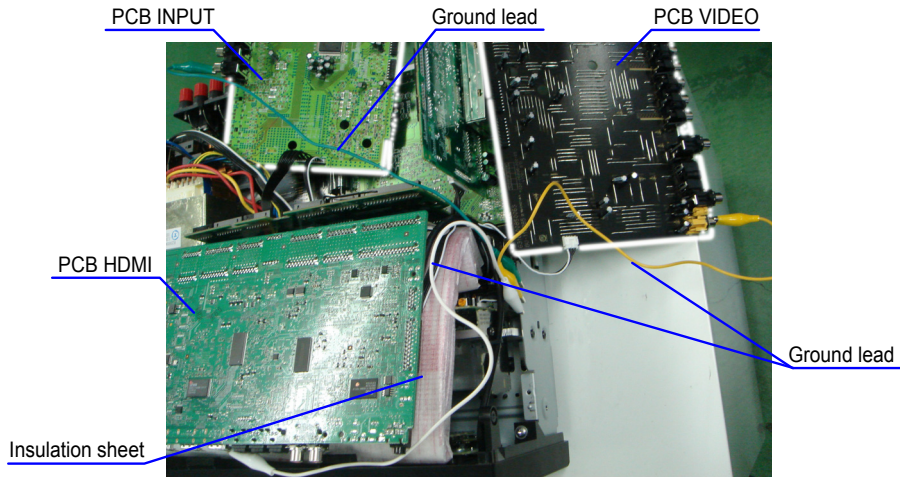

- (4) Connect the four extension jig cables.

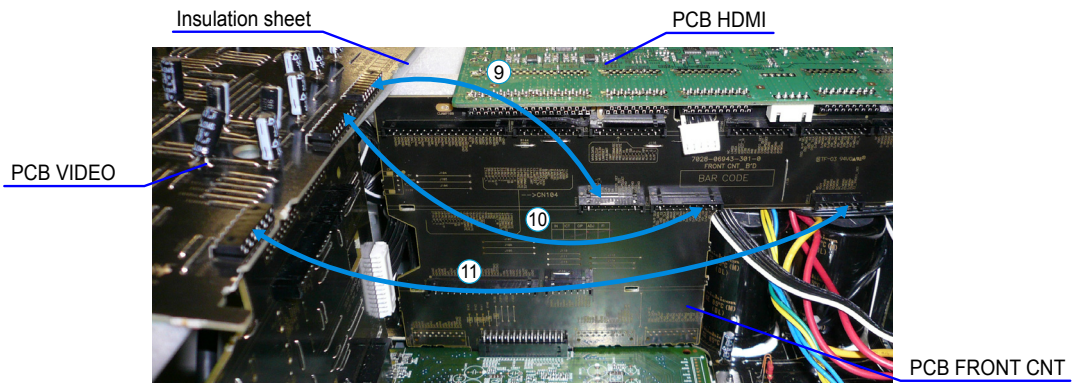
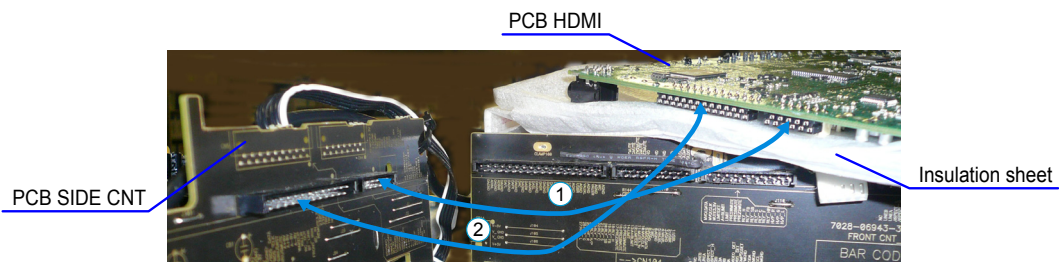
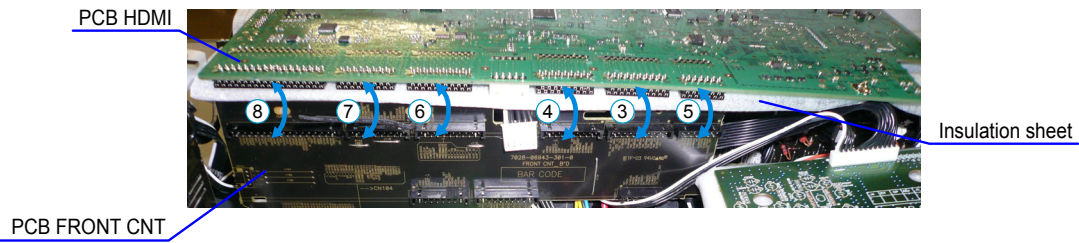

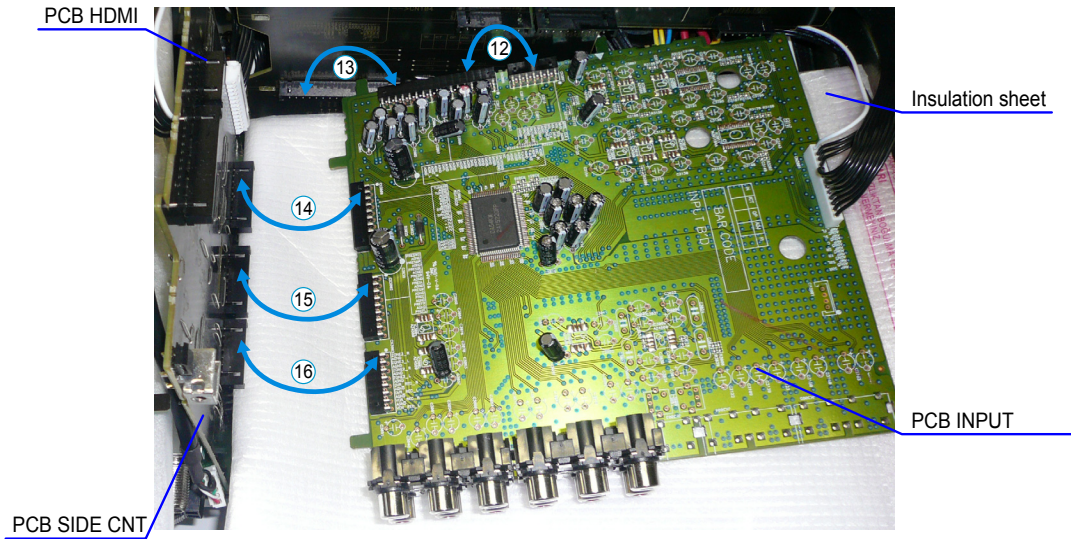

**Connection table of Board to Board**

No.	Pin	Ref. No.	PCB		Ref. No.	PCB
①	11 pin	CP3	SIDE CNT	↔	N4908	HDMI
②	25 pin	CP4	SIDE CNT	↔	N4907	HDMI
③	19 pin	CP105	FRONT CNT	↔	N4910	HDMI
④	17 pin	CP106	FRONT CNT	↔	N4911	HDMI
⑤	13 pin	CP107	FRONT CNT	↔	N4912	HDMI
⑥	19 pin	CP108	FRONT CNT	↔	N4913	HDMI
⑦	17 pin	CP109	FRONT CNT	↔	N4914	HDMI
⑧	33 pin	CP110	FRONT CNT	↔	N4916	HDMI
⑨	19 pin	CP111	FRONT CNT	↔	N2001	VIDEO
⑩	17 pin	CP112	FRONT CNT	↔	N2002	VIDEO
⑪	13 pin	CP113	FRONT CNT	↔	N2003	VIDEO
⑫	13 pin	CP114	FRONT CNT	↔	CX3001	INPUT
⑬	33 pin	CP115	FRONT CNT	↔	CN3000	INPUT
⑭	19 pin	CP6	SIDE CNT	↔	CX3000	INPUT
⑮	17 pin	CP7	SIDE CNT	↔	CX3002	INPUT
⑯	15 pin	CP8	SIDE CNT	↔	CX3003	INPUT

# ABOUT REPLACE THE MICROPROCESSOR WITH A NEW ONE

When replaced of the U-PRO (Microprocessor) or the Flash ROM, confirm contents of the following.

PWB Name	Ref. No.	Description	After replaced	Remark
HDMI	U5301	R5F64169DFD	<b>B</b>	SOFTWARE: Main
HDMI	U5101	W19B160BBT7H	<b>B</b>	SOFTWARE: Main ROM
HDMI	U5500	R5F3650KNFB	<b>B</b>	SOFTWARE: Sub
HDMI	U3202	EN29LV160BB-70TIP	<b>B</b>	SOFTWARE: DSP ROM
HDMI	U3000	EPM240T100C5N	<b>B</b>	SOFTWARE: Audio PLD
HDMI	U1603	M25P40-VMN6PB	<b>B</b>	SOFTWARE: Video Config ROM

After replaced

**A** : Mask ROM (With software). No need write-in of software to the microprocessor.

**B** : Flash ROM (With software). Usually, no need write-in of software. But, when the software was updated, you should be write-in of the new software to the microprocessor or flash ROM. Please check the software version.

**C** : Empty Flash ROM (Without software). You should be write-in of the software to the microprocessor or flash ROM. Refer to "Update procedure" or "writing procedure", when you should be write-in the software.

## VERSION UPGRADE PROCEDURE OF FIRMWARE

### 1. Preparations before starting the operation

- (1) Personal Computer (Installed "DFW\_0004\_SR6005\_(Rev.1.0.6)".exe).
- (2) RS-232C cable (9P (Male), Straight).

### 2. Connection of the AV receiver

- (1) Confirm the power on/off switch of the AV receiver is turning off.
- (2) Connect the RS-232C cable from PC with the AV receiver.

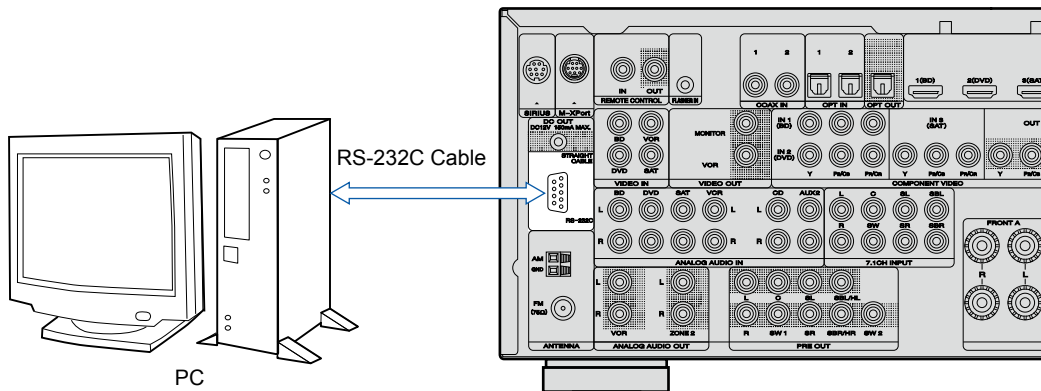

### 3. Turn on the AV receiver

Operate the following. Turn on the AV receiver.

- (1) Connect the power cable to the AC outlet while simultaneously pushing the "CURSOR ◀" button and the "RETURN" button of the front panel.
- (2) Confirm the power indicator is green and "WRITING" is displayed in the front panel.

#### 4. Run the DFW

Run the "DFW\_0004\_SR6005\_(Rev.1.0.6)" on desktop of PC.



#### 5. Communication check

(1) Click the "Check Comm." button.

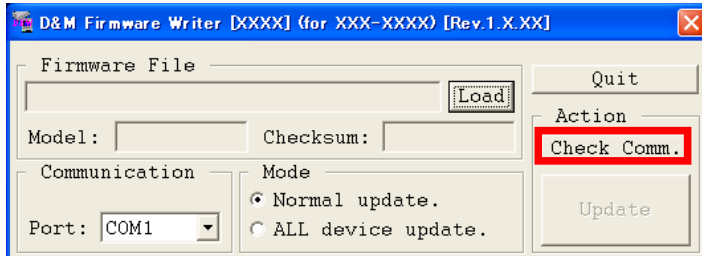

(2) When connection is good, then you can see the "Communication check OK." message.



(3) If connection is not good, then you can see the "Communication check NG" message.



Please confirm the following

- Check the connection of the AV receiver and PC. (refer to "2.Connection of the AV receiver")
- Check the operation mode of the AV receiver. (refer to "3.Turn on the AV receiver")
- Check the selection of the RS-232C port number of PC.

## 6. Download the firmware

- (1) Click the "Load" button.

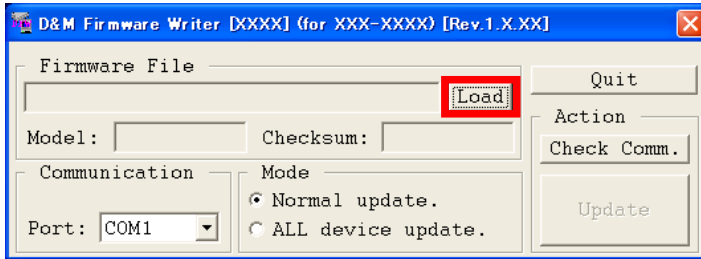

- (2) Download the firmware from the specified download source to PC.

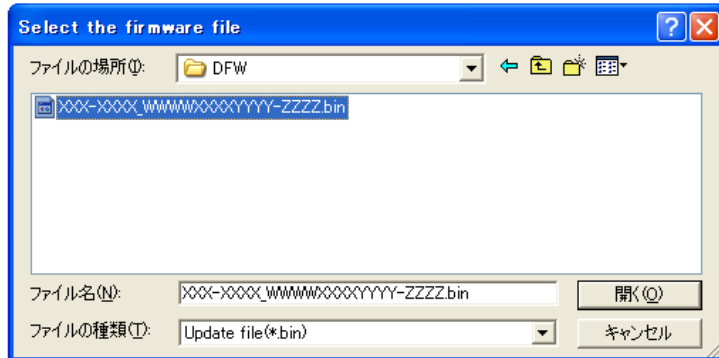

## 7. Complete the firmware updating

- (1) Click the "Update" button.

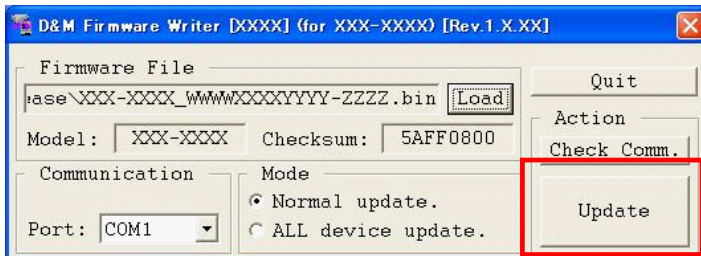

- (2) When writing of the firmware is completed, the power of this unit turns on automatically and you can see the "Update completed" message.

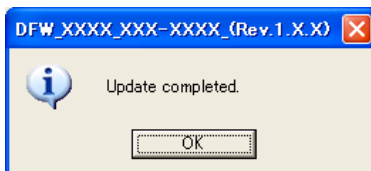

- (3) If you can't complete the firmware update, please retry the firmware update from "3. Turn on the AV receiver".

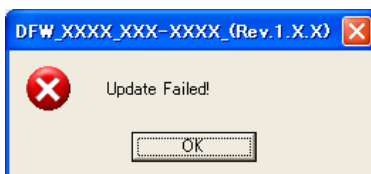

## **8. Notice:**

Please keep the following notice for firmware update.

- (a) Keep the PC environment
- (b) Avoid the communication cable from the electrical noise source.  
(e.g. telephone cable, AC line, a fluorescent light)
- (c) Don't remove cable during update.
- (d) Don't turn off the power during update.
- (e) Don't run other PC application during update.
- (f) Stop the resident program on PC (Virus checker and System check utility, etc)
- (g) Stop the screen saver on PC.
- (h) Stop the power save ability on PC.
- (i) In case of laptop PC, Use the AC adaptor.

## **Confirming the firmware's number after upgraded**

After completion of the updating operation, the new version number can be confirmed by starting up the SR6005 according to the following procedure.

With the following operation, the SR6005 can be set to the Flash ROM Version-Number Confirmation mode.

Turn on power switch while simultaneously pressing "STATUS" and "RETURN" buttons on the front panel. Every time the "STATUS" button is pressed, version number of the Model, Main, Sub, ... are indicated on the front panel section in the following order.

# SURROUND MODES AND PARAMETERS

## Symbols in the table

- This indicates the audio output channels or surround parameters that can be set.
- ⊙ This indicates the audio output channels. The output channels depend on the settings of "Speaker Config."

Surround mode	Channel output					Surround Parameter					
	Front L/R	Center	Surround L/R	Surround Back L/R	Front Height L/R	Subwoofer	HT-EQ *3	DRC *4	D. Comp *5	LFE *6	
PURE DIRECT (2channel)	○					⊙ *2					
PURE DIRECT (Multi-channel)	○	⊙	⊙	⊙ *1	⊙ *1	⊙				○	
DIRECT (2channel)	○					⊙ *2				○	
DIRECT (Multi-channel)	○	⊙	⊙	⊙ *1	⊙ *1	⊙				○	
STEREO	○					⊙				○	
MULTI CH IN	○	⊙	⊙	⊙		⊙				○	
DOLBY PRO LOGIC IIz	○	⊙	⊙	⊙	⊙	⊙					
DOLBY PRO LOGIC IIx	○	⊙	⊙	⊙		⊙					
DOLBY PRO LOGIC II	○	⊙	⊙	⊙		⊙					
DTS NEO6	○	⊙	⊙	⊙		⊙					
DOLBY DIGITAL	○	⊙	⊙	⊙	⊙	⊙				○	
DOLBY DIGITAL Plus	○	⊙	⊙	⊙	⊙	⊙				○	
DOLBY TrueHD	○	⊙	⊙	⊙	⊙	⊙				○	
DTS SURROUND	○	⊙	⊙	⊙	⊙	⊙				○	
DTS 96/24	○	⊙	⊙	⊙	⊙	⊙				○	
DTS-HD	○	⊙	⊙	⊙	⊙	⊙				○	
DTS Express	○	⊙	⊙	⊙	⊙	⊙				○	
MULTI CH STEREO	○	⊙	⊙	⊙		⊙				○	
DOLBY VIRTUAL SPEAKER	○					⊙ *2				○	
Neural	○	⊙	⊙	⊙		⊙				○	
Dolby Headphone	○										

- \*1 A signal for each channel contained in an input signal is output as audio.
- \*2 Only when "Subwoofer Mode" is set to "LFE+Main", sound is output from the subwoofer.
- \*3 For HD Audio whose sampling frequency of an input signal is more than 96kHz, this sound parameter cannot be set.
- \*4 This item can be selected when a Dolby TrueHD signal is played.
- \*5 This item can be selected when a Dolby Digital or DTS signal is played.
- \*6 This item can be selected when a Dolby Digital or DTS signal or DVD-Audio is played.



Surround mode	Surround Parameter					Tone * 7	Audyssey Settings * 11			M-DAX * 10
	Height Gain	Panorama	PRO LOGIC II/IX Music mode only		NEO:6 Music mode only		MultEQ®	Dynamic EQ® * 8	Dynamic Volume® * 9	
			Dimension	C. Width	C. Image					
PURE DIRECT (2 channel)										
PURE DIRECT (Multi-channel)										
DIRECT (2 channel)										
DIRECT (Multi-channel)										
STEREO							<input type="radio"/>	<input type="radio"/>	<input type="radio"/>	<input type="radio"/>
MULTI CH IN							<input type="radio"/>	<input type="radio"/>	<input type="radio"/>	<input type="radio"/>
DOLBY PRO LOGIC IIz	<input type="radio"/>						<input type="radio"/>	<input type="radio"/>	<input type="radio"/>	<input type="radio"/>
DOLBY PRO LOGIC IX		<input type="radio"/>	<input type="radio"/>				<input type="radio"/>	<input type="radio"/>	<input type="radio"/>	<input type="radio"/>
DOLBY PRO LOGIC II		<input type="radio"/>	<input type="radio"/>				<input type="radio"/>	<input type="radio"/>	<input type="radio"/>	<input type="radio"/>
DTS NEO:6							<input type="radio"/>	<input type="radio"/>	<input type="radio"/>	<input type="radio"/>
DOLBY DIGITAL							<input type="radio"/>	<input type="radio"/>	<input type="radio"/>	<input type="radio"/>
DOLBY DIGITAL Plus							<input type="radio"/>	<input type="radio"/>	<input type="radio"/>	<input type="radio"/>
DOLBY TrueHD							<input type="radio"/>	<input type="radio"/>	<input type="radio"/>	<input type="radio"/>
DTS SURROUND							<input type="radio"/>	<input type="radio"/>	<input type="radio"/>	<input type="radio"/>
DTS 96/24							<input type="radio"/>	<input type="radio"/>	<input type="radio"/>	<input type="radio"/>
DTS-HD							<input type="radio"/>	<input type="radio"/>	<input type="radio"/>	<input type="radio"/>
DTS Express							<input type="radio"/>	<input type="radio"/>	<input type="radio"/>	<input type="radio"/>
MULTI CH STEREO							<input type="radio"/>	<input type="radio"/>	<input type="radio"/>	<input type="radio"/>
DOLBY VIRTUAL SPEAKER							<input type="radio"/>	<input type="radio"/>	<input type="radio"/>	<input type="radio"/>
Neural							<input type="radio"/>	<input type="radio"/>	<input type="radio"/>	<input type="radio"/>
Dolby Headphone							<input type="radio"/>	<input type="radio"/>	<input type="radio"/>	<input type="radio"/>

\* 7 This item cannot be set when "Dynamic EQ" is set to "ON".

\* 8 This item cannot be set when "MultEQ" is set to "OFF" or "Manual".

\* 9 This item cannot be set when "Dynamic EQ" is set to "OFF".

\* 10 This item can be set when the input signal is analog, PCM 48 kHz or 44.1 kHz.

\* 11 For HD Audio whose sampling frequency of an input signal is more than 96 kHz, this sound parameter cannot be set.

## Symbols in the table

○ This indicates the selectable surround mode.

Surround mode	NOTE	Input signal types and formats															
		ANALOG		PCM		DTS-HD		DTS		DOLBY		DOLBY DIGITAL					
		LINEAR PCM (multi ch)	LINEAR PCM (2ch)	DTS-HD Master Audio	DTS-HD High Resolution Audio	DTS EXPRESS	DTS ES DSCRT (With Flag)	DTS ES MTRX (With Flag)	DTS (5.1ch)	DTS 96/24	DOLBY TrueHD	DOLBY DIGITAL Plus	DOLBY DIGITAL EX (With Flag)	DOLBY DIGITAL EX (With no Flag)	DOLBY DIGITAL (5.1/5+4ch)	DOLBY DIGITAL (2ch)	
<b>DTS SURROUND</b>																	
DTS-HD MSTR				○													
DTS-HD HI RES				○													
DTS ES DSCRT6.1	*1 *4							○									
DTS ES MTRX6.1	*1 *4							○									
DTS SURROUND								○									
DTS 96/24									○								
DTS (-HD) + PLIx MOVIE	*2 *4			○				○									
DTS (-HD) + PLIx MUSIC	*1 *4			○				○									
DTS (-HD) + PLIz	*3			○				○									
DTS EXPRESS								○									
DTS (-HD) + NEO:6	*1 *4			○				○									
DTS NEO:6 CINEMA		○															○
DTS NEO:6 MUSIC		○															○
<b>DOLBY SURROUND</b>																	
DOLBY TrueHD										○							
DOLBY DIGITAL+																	
DOLBY DIGITAL EX	*1 *4																○
DOLBY (D+) (HD) +EX	*1 *4									○							○
DOLBY DIGITAL																	○
DOLBY (D) (D+) (HD) +PLIx MOVIE	*2 *4																○
DOLBY (D) (D+) (HD) +PLIx MUSIC	*1 *4																○
DOLBY (D) (D+) (HD) +PLIz	*3																○
DOLBY PRO LOGIC Ix MOVIE	*1 *4																○
DOLBY PRO LOGIC Ix MUSIC	*1 *4																○
DOLBY PRO LOGIC Ix GAME	*1 *4																○
DOLBY PRO LOGIC IIz	*3																○
DOLBY PRO LOGIC II MOVIE																	○
DOLBY PRO LOGIC II MUSIC																	○
DOLBY PRO LOGIC II GAME																	○
DOLBY VIRTUAL SPEAKER																	○
DOLBY HEADPHONE																	○

\*1 If "Speaker Config." - "S Back" is set to "None", this surround mode cannot be selected.

\*2 If "Speaker Config." - "S Back" is set to "1spkr" or "None", this surround mode cannot be selected.

\*3 If "Speaker Config." - "F. Height" is set to "None", this surround mode cannot be selected.

\*4 This surround mode can be selected when "Amp Assign" is set to "Normal".

Surround mode	NOTE	Input signal types and formats															
		ANALOG	PCM		DTS-HD		DTS			DOLBY		DOLBY DIGITAL					
			LINEAR PCM (multi ch)	LINEAR PCM (2ch)	DTS-HD Master Audio	DTS-HD High Resolution Audio	DTS EXPRESS	DTS-ES DSCRT (With Flag)	DTS-ES MTRX (With Flag)	DTS (5.1ch)	DTS 96/24	DOLBY TrueHD	DOLBY DIGITAL Plus	DOLBY DIGITAL EX (With Flag)	DOLBY DIGITAL EX (With no Flag)	DOLBY DIGITAL (5.1/5/4ch)	DOLBY DIGITAL (2ch)
MULTI CH IN																	
MULTI CH IN		<input type="radio"/>															
MULTI CH IN + PLIIx MOVIE	*2 *4	<input type="radio"/>															
MULTI CH IN + PLIIx MUSIC	*1 *4	<input type="radio"/>															
MULTI CH IN + PLIIz	*3	<input type="radio"/>															
MULTI CH IN + Dolby EX	*1 *4	<input type="radio"/>															
MULTI CH IN 7.1	*1 *4	<input type="radio"/>															
DIRECT		<input type="radio"/>															
PURE DIRECT		<input type="radio"/>															
MULTI CH STEREO		<input type="radio"/>															
STEREO		<input type="radio"/>															
NEURAL		<input type="radio"/>															
AUTO		<input type="radio"/>															

\*1 If "Speaker Config." - "S.Back" is set to "None", this surround mode cannot be selected.

\*2 If "Speaker Config." - "S.Back" is set to "Isprk" or "None", this surround mode cannot be selected.

\*3 If "Speaker Config." - "F.Height" is set to "None", this surround mode cannot be selected.

\*4 This surround mode can be selected when "Amp Assign" is set to "Normal".

# ADJUSTMENT

## Audio Section

### Idling Current

Required measurement equipment: DC Voltmeter

#### 1. Preparation

- (1) Avoid direct blow from an air conditioner or an electric fan, and adjust the unit at normal room temperature 15 °C ~ 30 °C (59 °F ~ 86 °F).
- (2) Presetting
  - POWER (Power source switch) STANDBY
  - SPEAKER (Speaker terminal) No load  
(Do not connect speaker, dummy resistor, etc.)

#### 2. Adjustment

- (1) Remove top cover and set VR401, VR402, VR403, VR404, VR405, VR406, VR407 on 7CH AMP UNIT at fully counterclockwise (⤵) position.
- (2) Connect DC Voltmeter to test points (FRONT-Lch: TP401, FRONT-Rch: TP402, CENTER ch: TP403, SURROUND-Lch: TP404, SURROUND-Rch: TP405, SURROUND-BACK Lch: TP406, SURROUND-BACK Rch: TP407).
- (3) Connect power cord to AC Line, and turn power switch "ON".
- (4) Presetting.
  - MASTER VOLUME : "----" counterclockwise (⤵ min.)
  - SPEAKER (Speaker terminal) : No load  
(Do not connect speaker, dummy resistor, etc.)
  - MODE : MCH STEREO
  - FUNCTION : DVD
- (5) Within 2 minutes after the power on, turn VR401 clockwise (⤴) to adjust the TEST POINT voltage to 8.0 mV ± 0.5 mV DC.
- (6) After 10 minutes from the preset above, turn VR401 to set the voltage to 8.0 mV ± 0.5 mV DC.
- (7) Adjust the Variable Resistors of other channels in the same way.

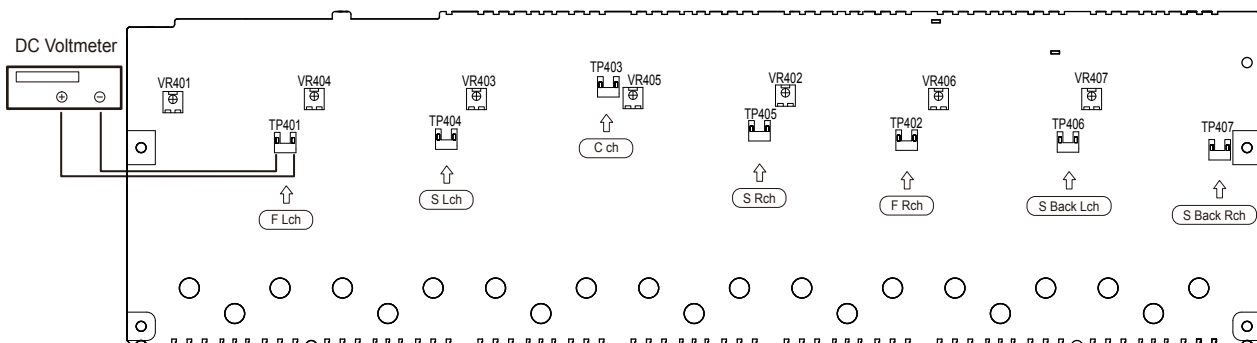
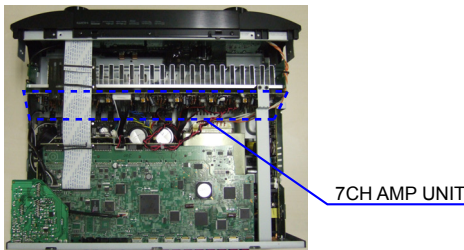

# TROUBLE SHOOTING

## 1. POWER

### 1.1. Power not turn on

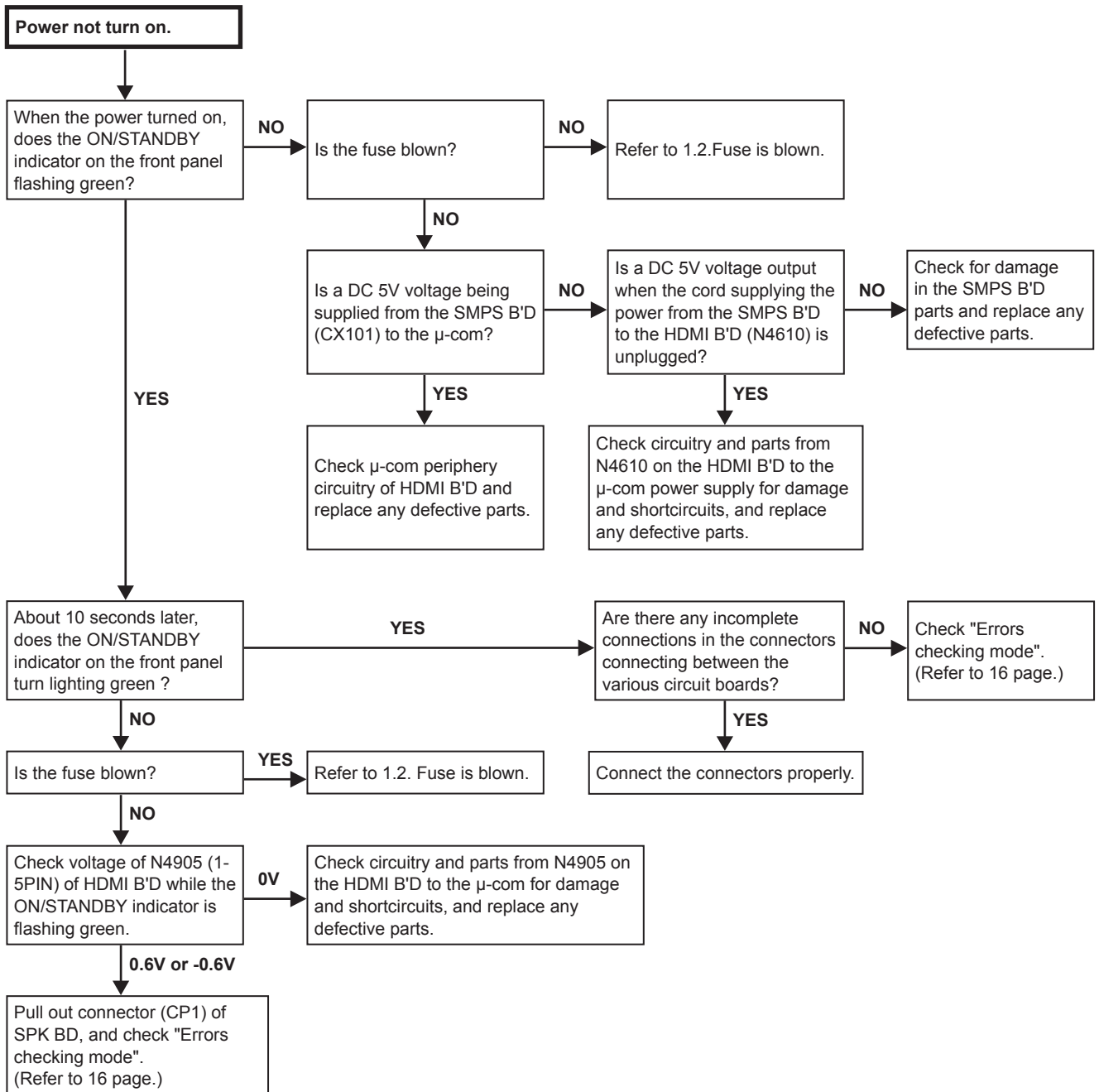

### 1.2. Fuse is blown

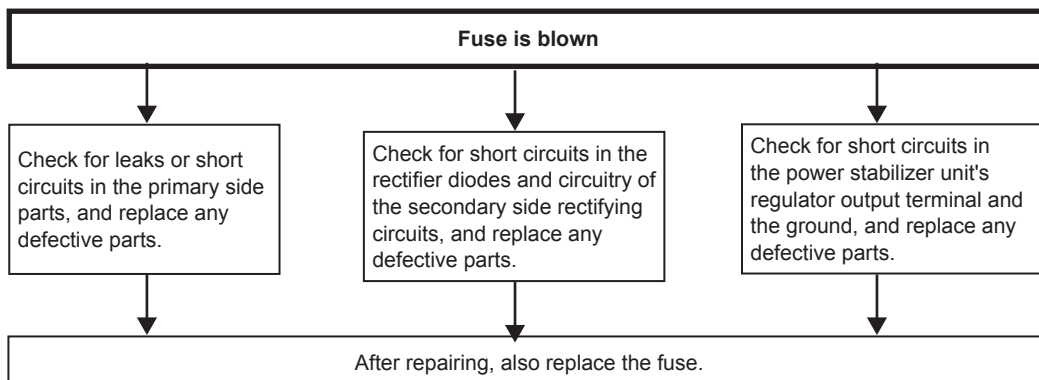

## 2. Analog video

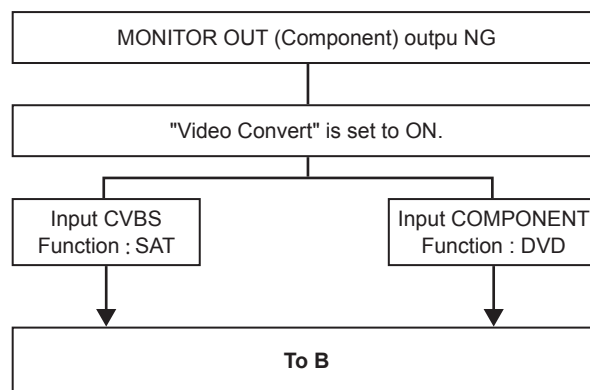
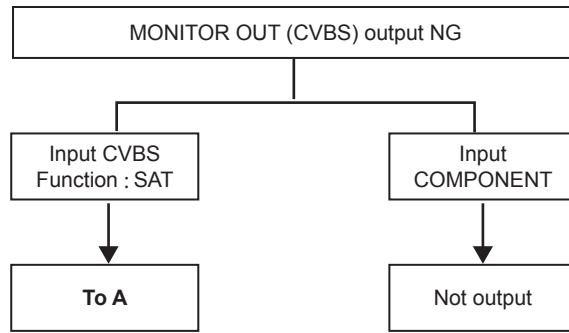

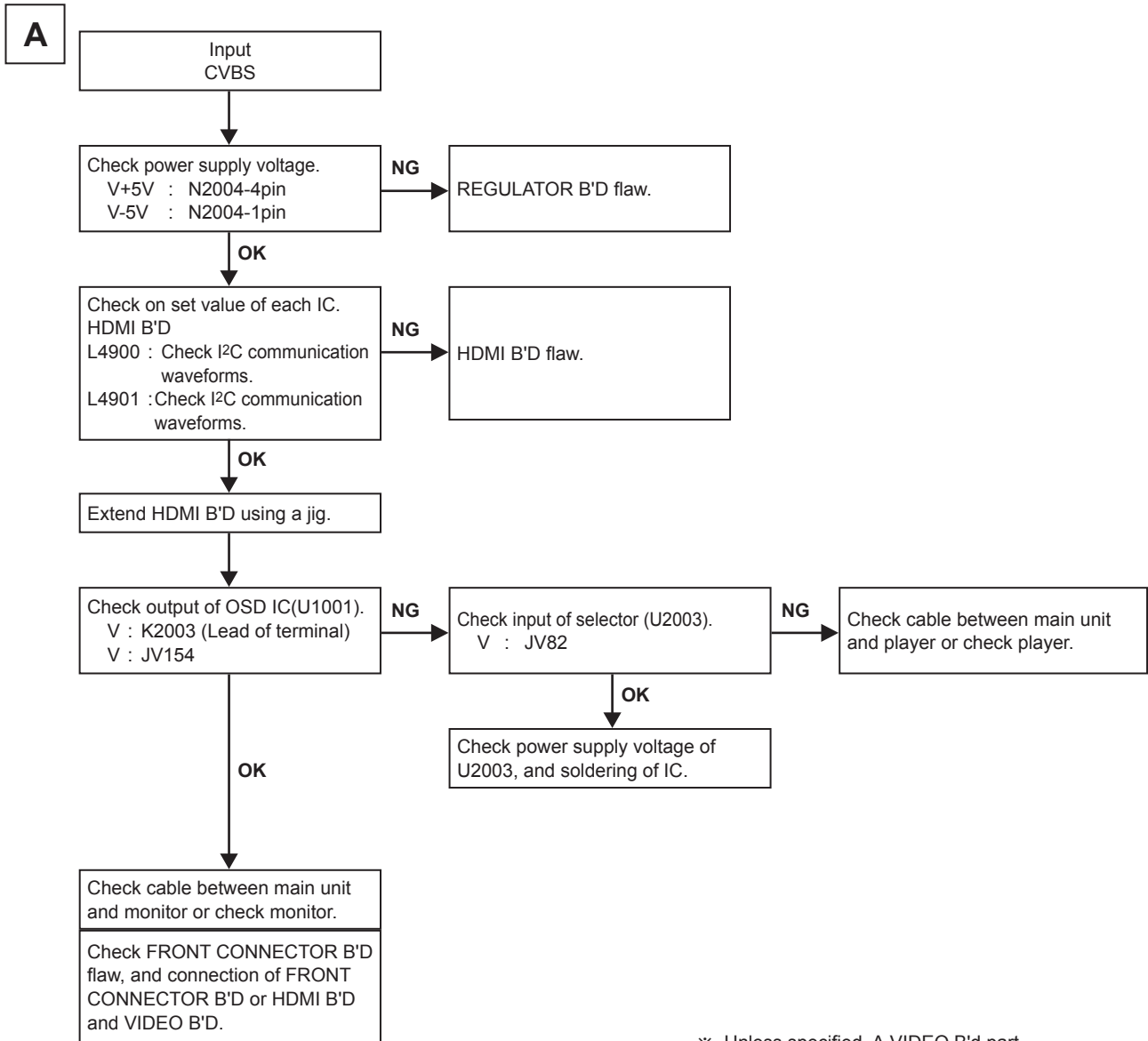

※ Unless specified, A.VIDEO B'd part.

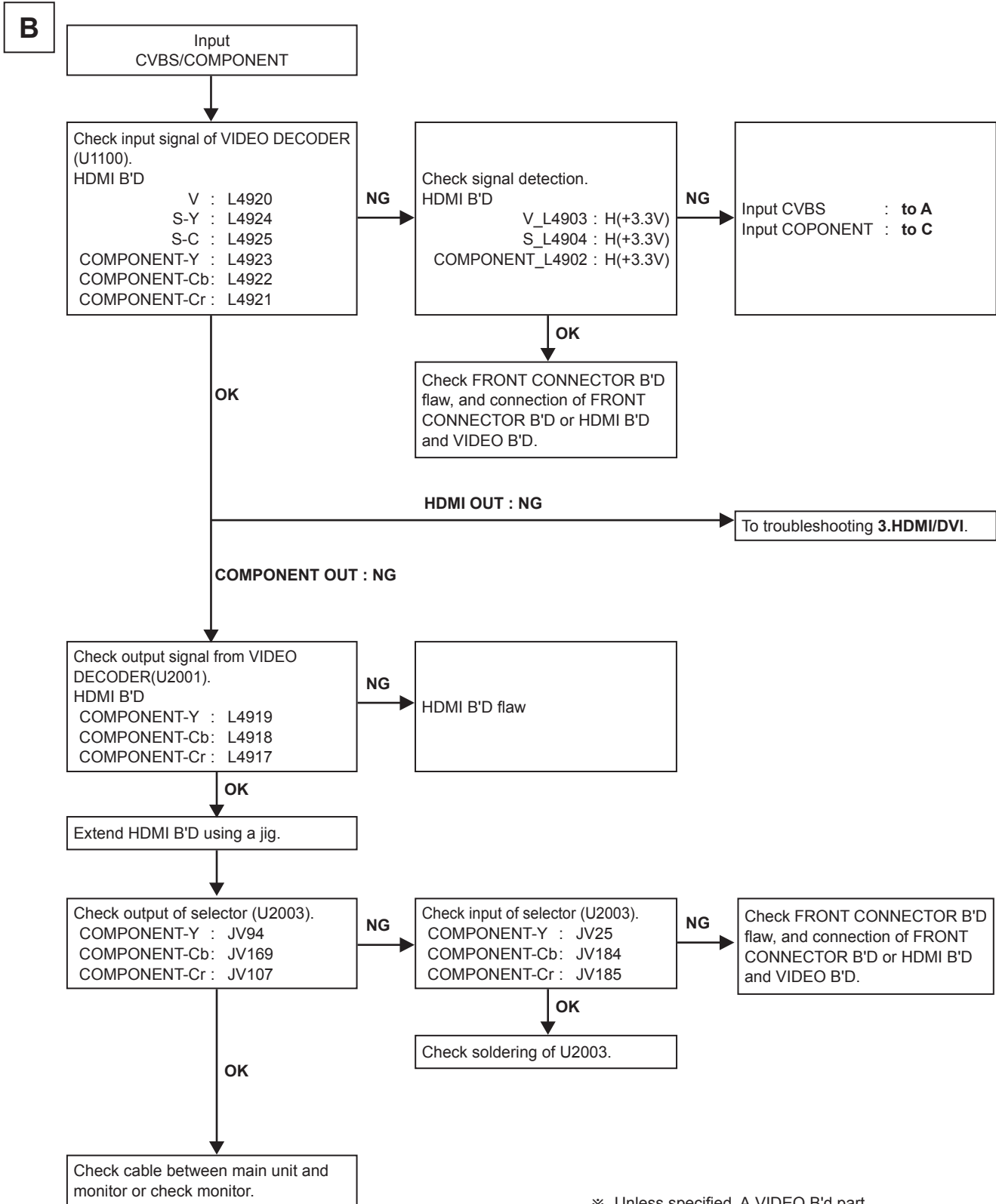

※ Unless specified, A.VIDEO B'd part.



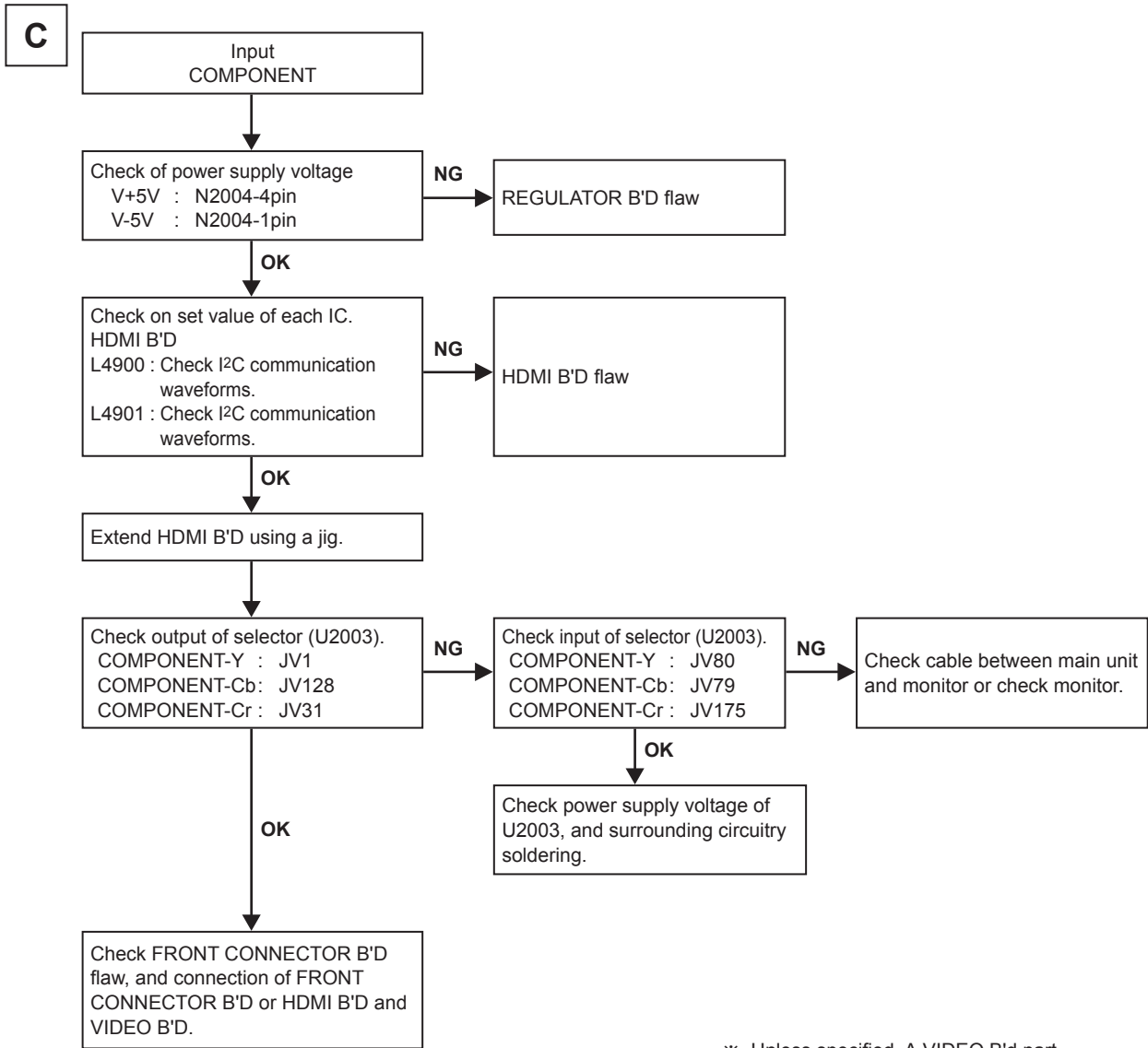

※ Unless specified, A.VIDEO B'd part.

### I2C communication waveforms

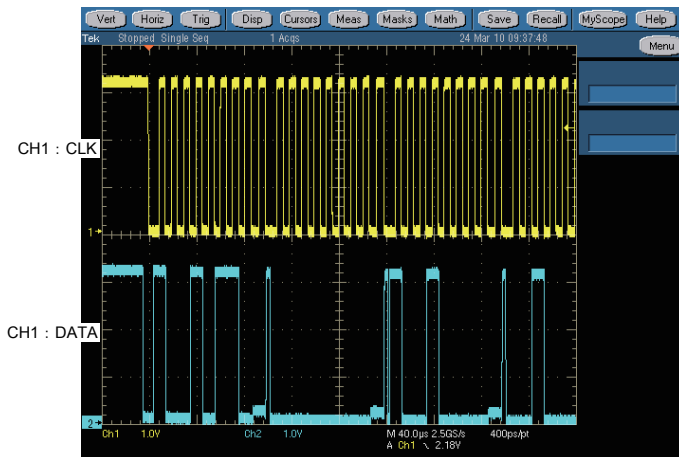

### 3. HDMI/DVI.

#### 3.1. No picture or sound is output

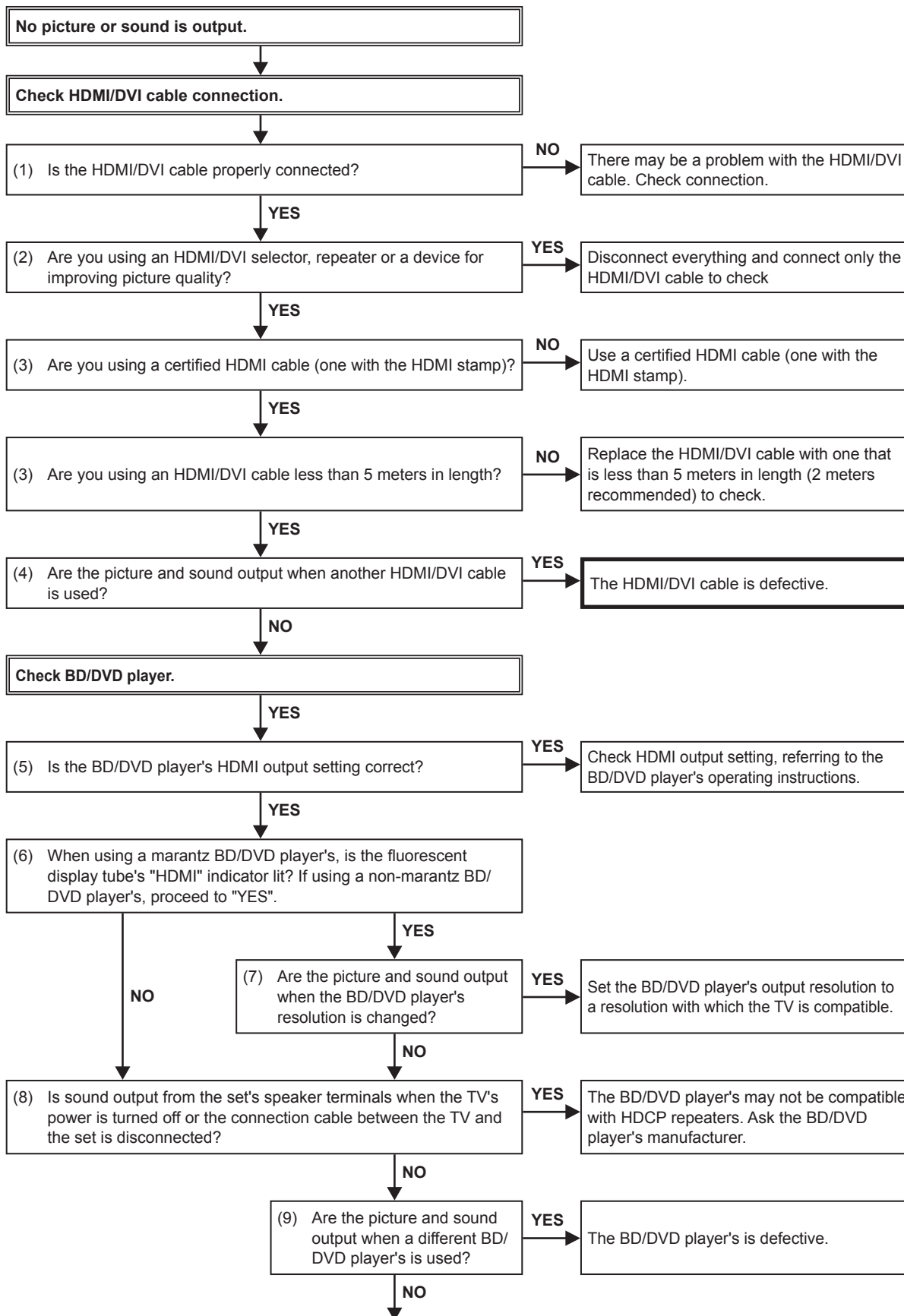

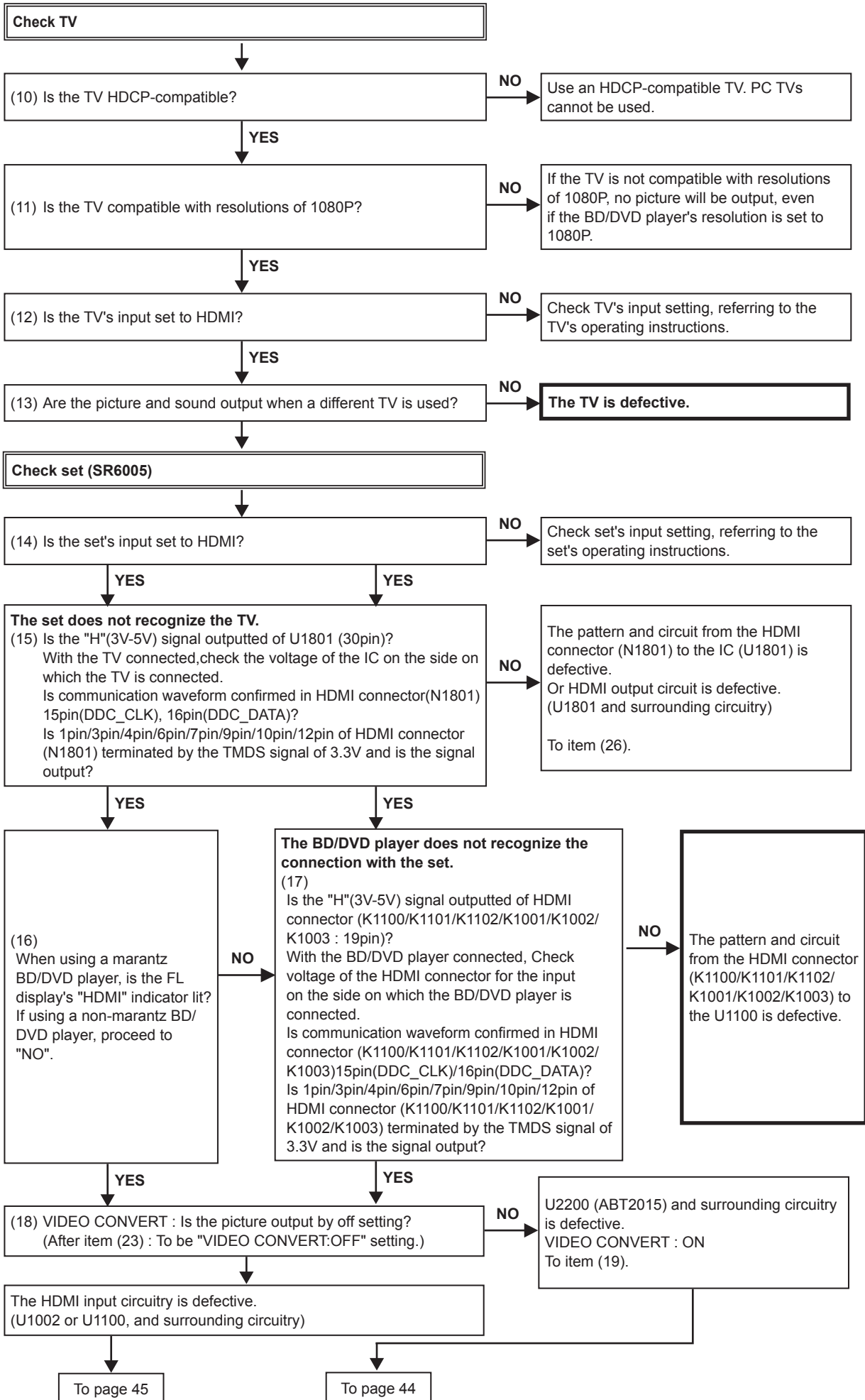

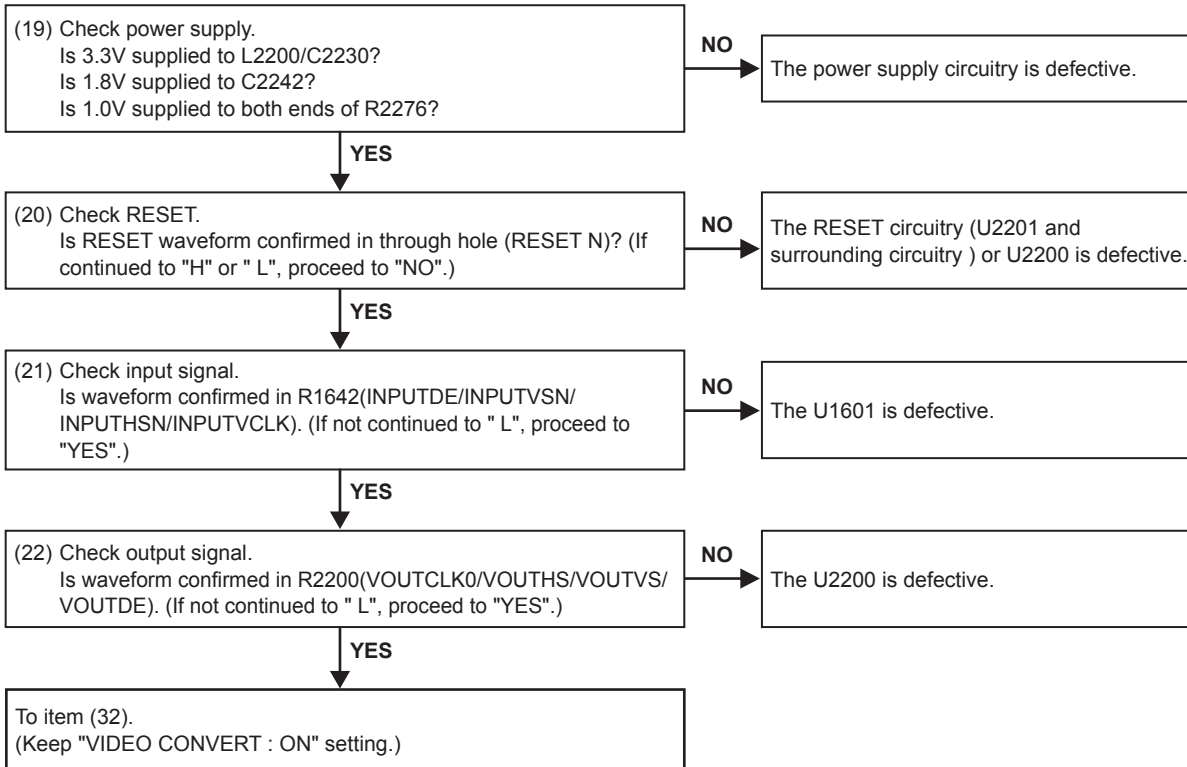

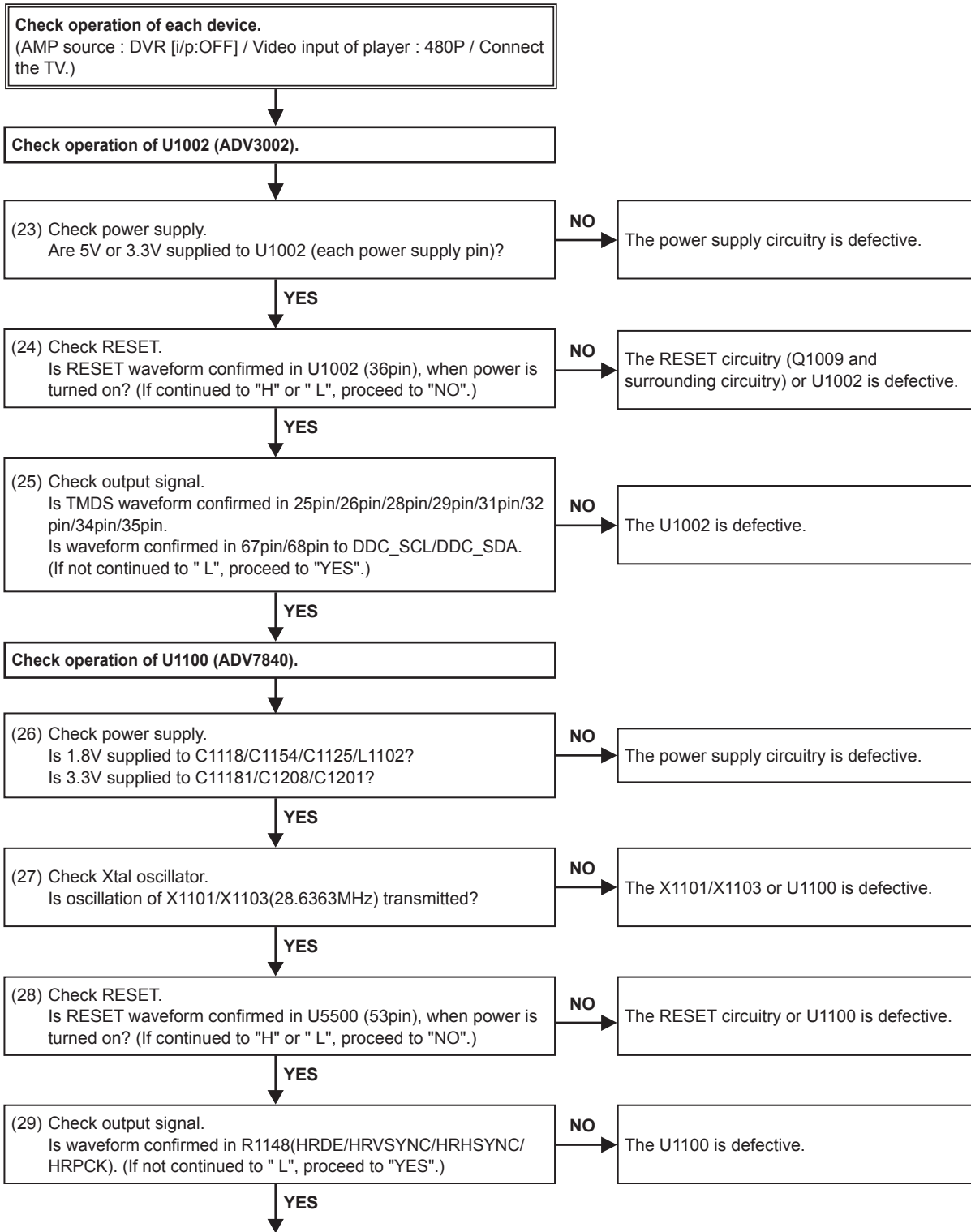

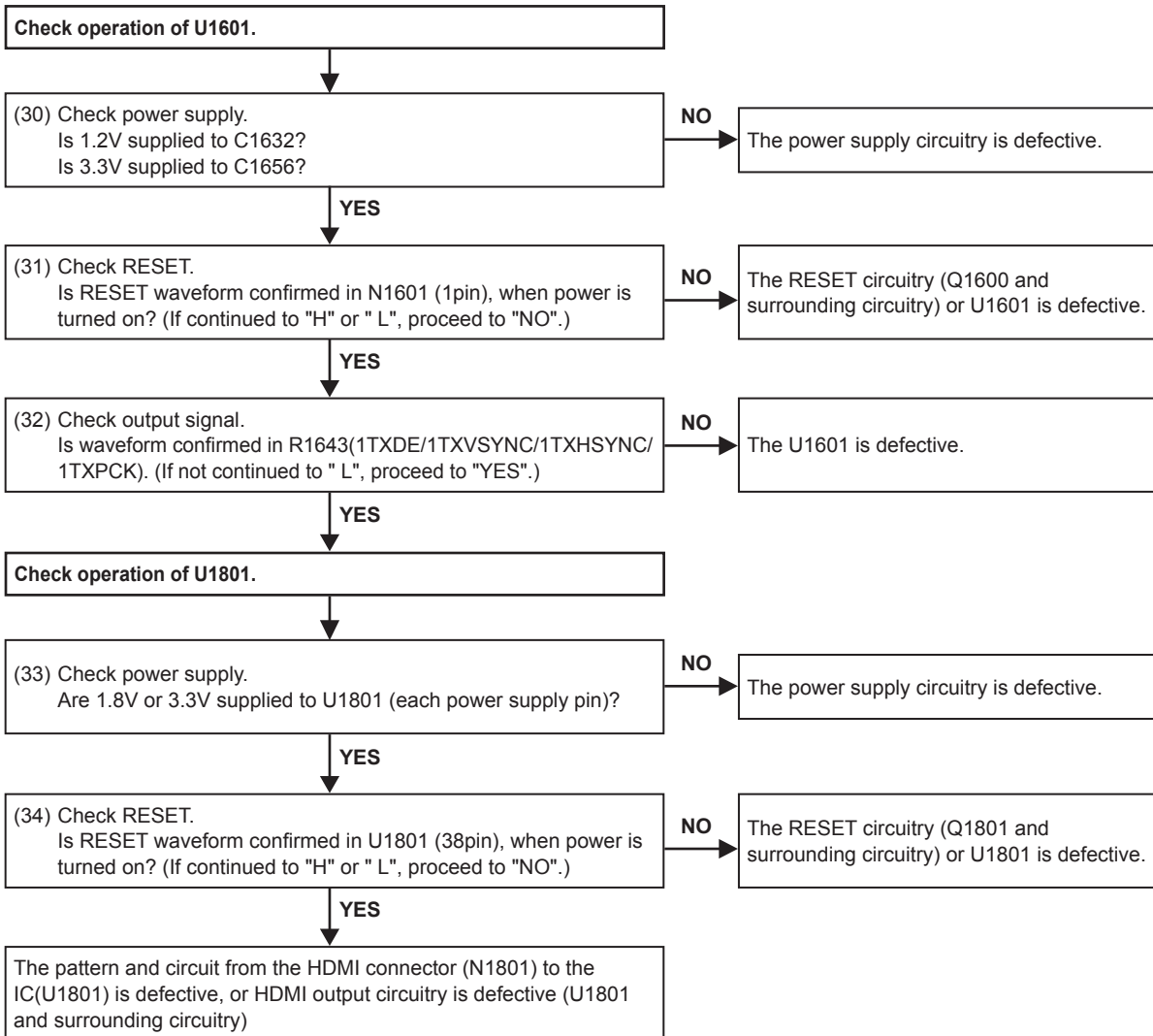

## 2.2. HDMI test point and waveforms

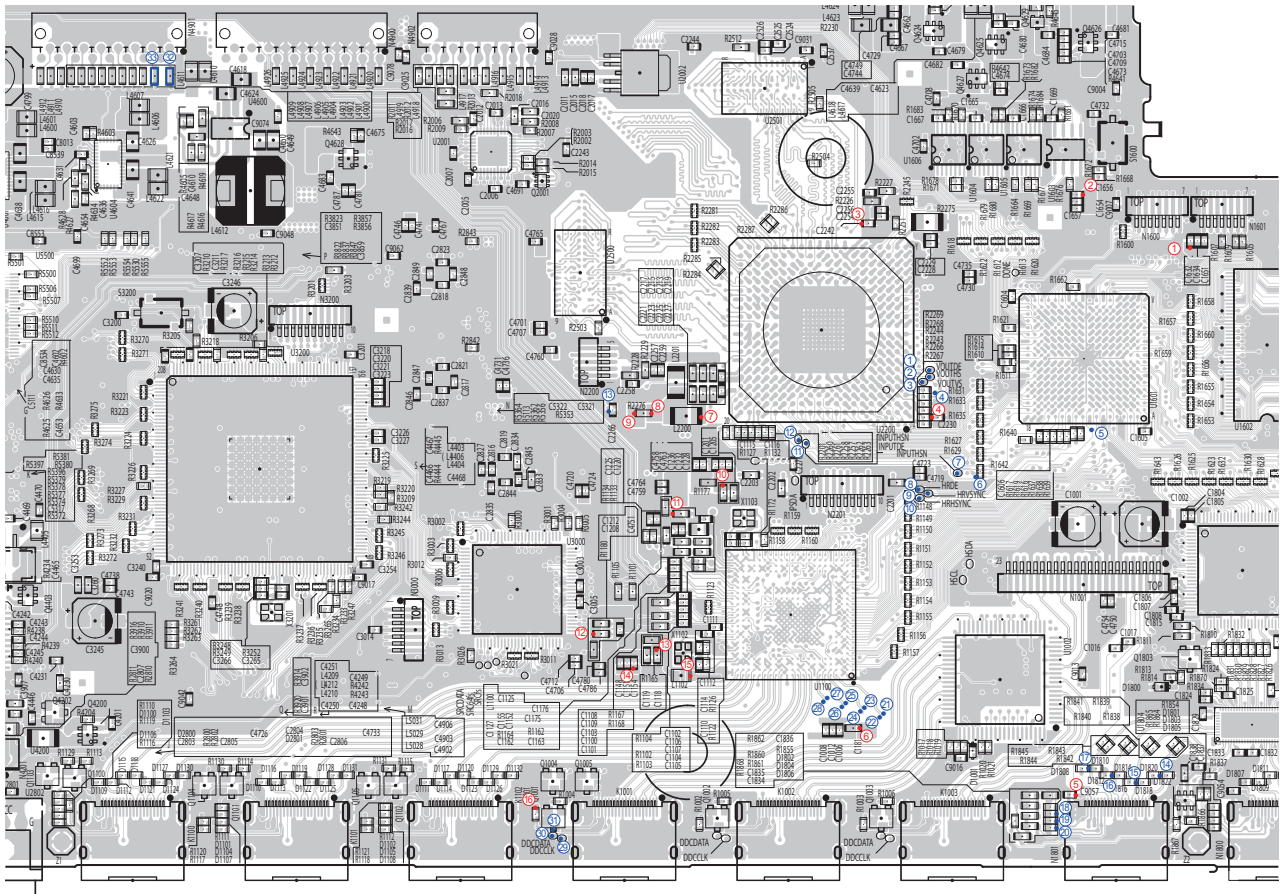
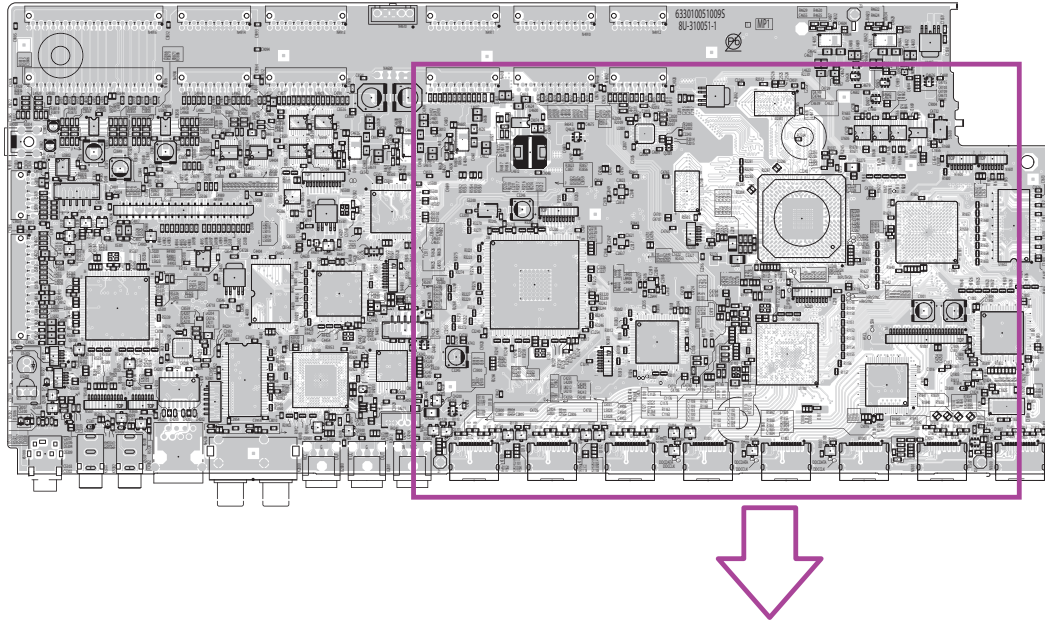

Check the voltage (Red)

No.	
1	1.2V
2	3.3V
3	1.8V
4	3.3V
5	+5V
6	3.3V
7	3.3V
8	1.0V
9	1.0V
10	3.3V
11	1.8V
12	3.3V
13	1.8V
14	1.8V
15	1.8V
16	+5V

Check the wave form (Blue)

No.		No.	
1	VOUTDE	18	HPD
2	VOUTH5	19	DDC_SDA
3	VOUTV5	20	DDC_SCL
4	VOUTCLK0	21	RXD_2+
5	HRPCK	22	RXD_2-
6	INPUTVCLK	23	RXD_1+
7	INPUTHSN	24	RXD_1-
8	HRDE	25	RXD_0+
9	HRVSYNC	26	RXD_0-
10	HRHSYNC	27	RXD_C+
11	INPUTDE	28	RXD_C-
12	INPUTVSN	29	DDC CLK
13	RESETN.	30	DDC DATA
14	D2+/D2-	31	HPD
15	D1+/D1-	32	I2C CLK
16	D0+/D0-	33	I2C DATA
17	CK+/CK-		



DDC\_CLK/DDC\_DATA/TMDS : Check item (15),(17),(25)

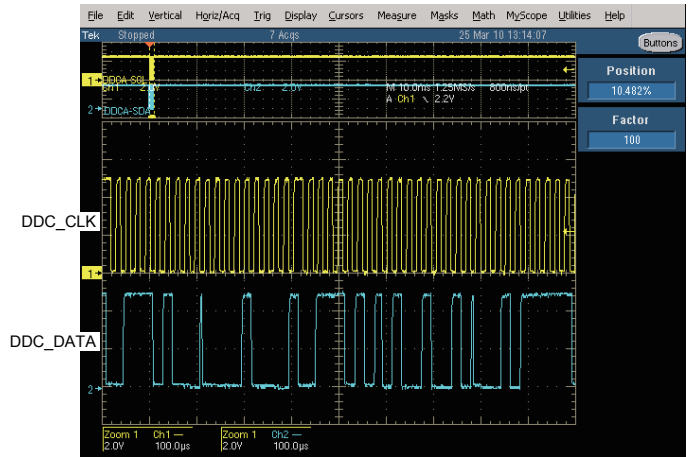
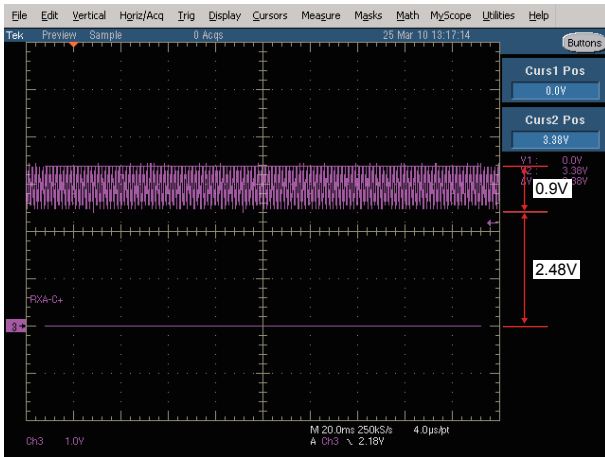

INPUTDE/INPUTVSN/INPUTHSN/INPUTVCLK : Check item (21)

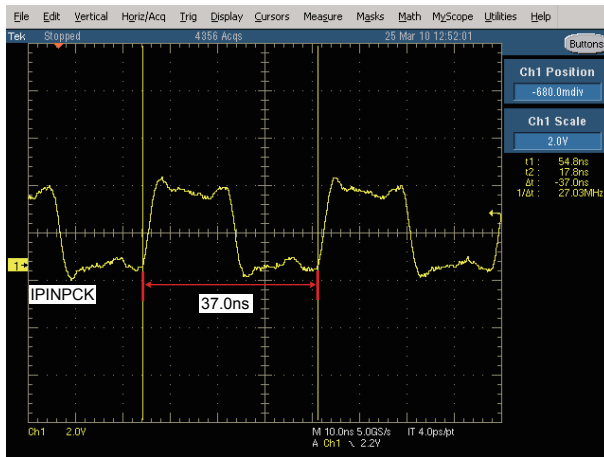
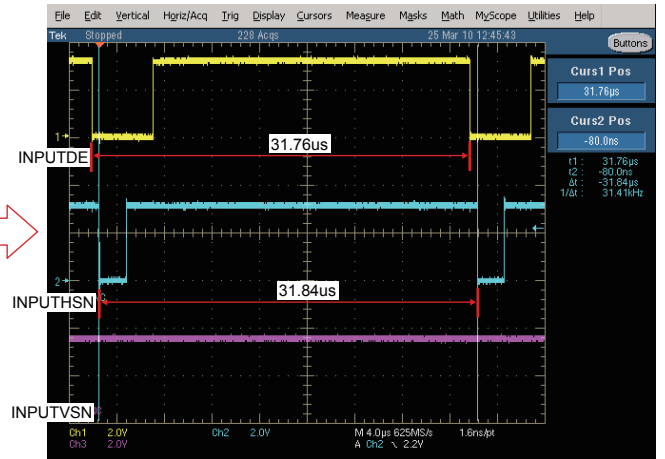
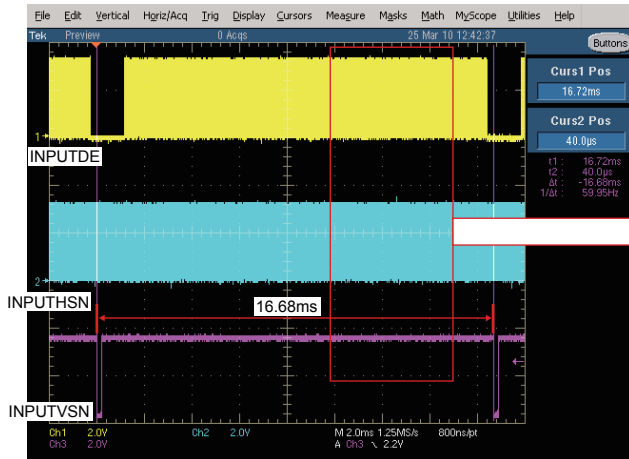

VOUTDE/VOUTVS/VOUTH0 : Check item (22)

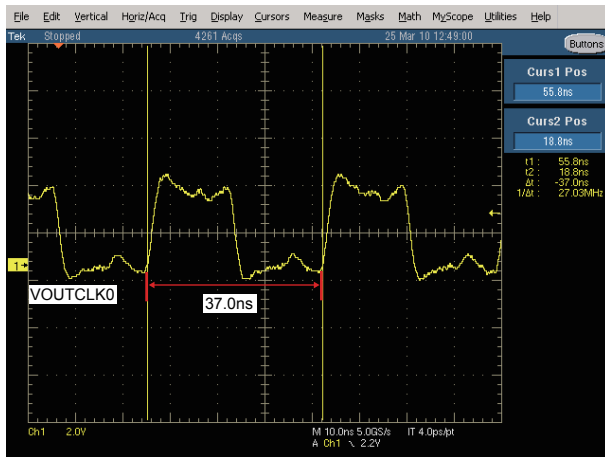
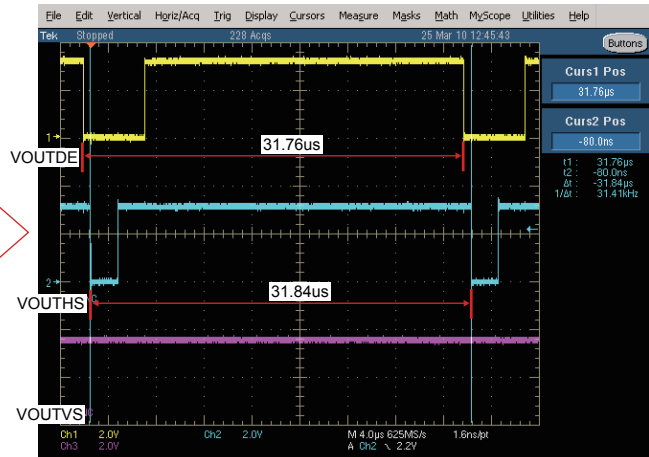
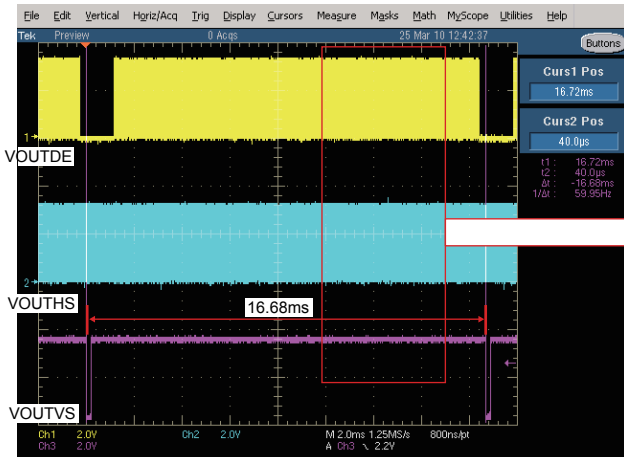

HRDE/HRVSYNC/HRHSYNC/HRPCK : Check item (29)

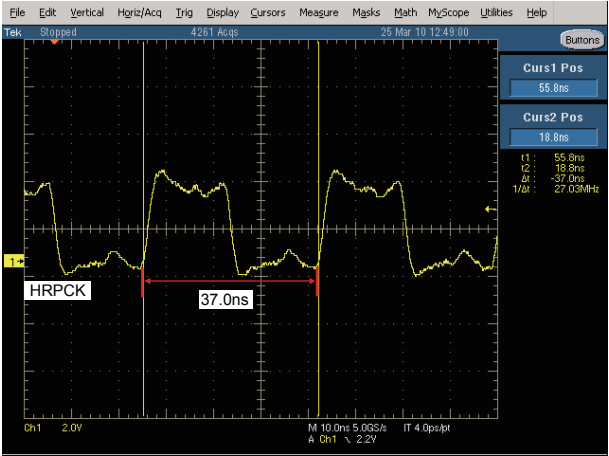
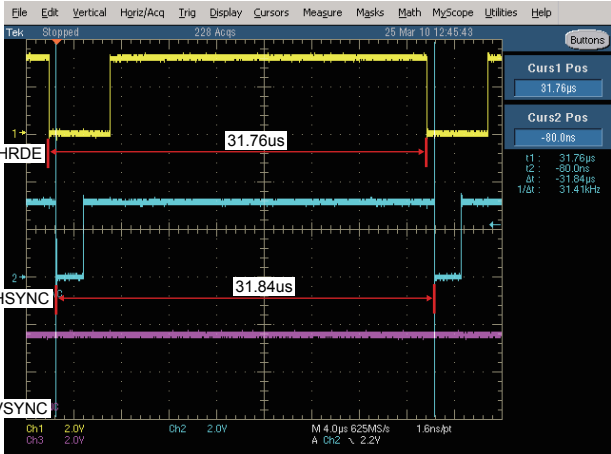
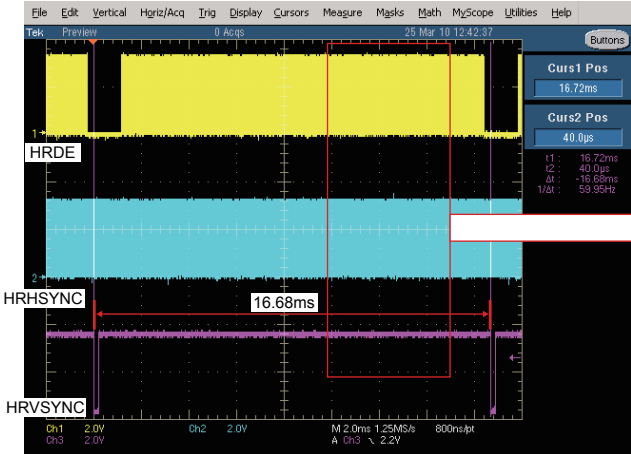

1TXDE/1TXVSYNC/1TXHSYNC/1TXPCK : Check item (32)

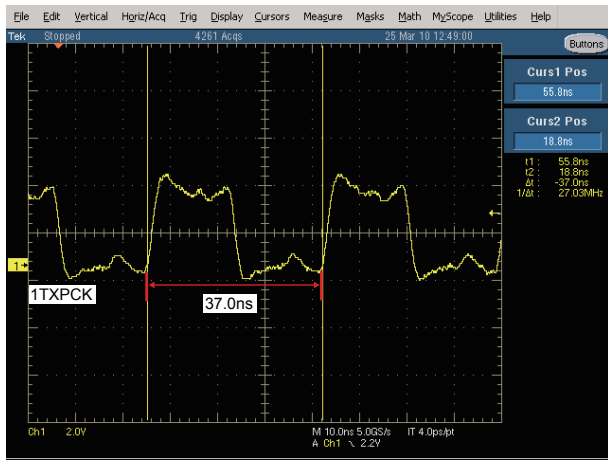
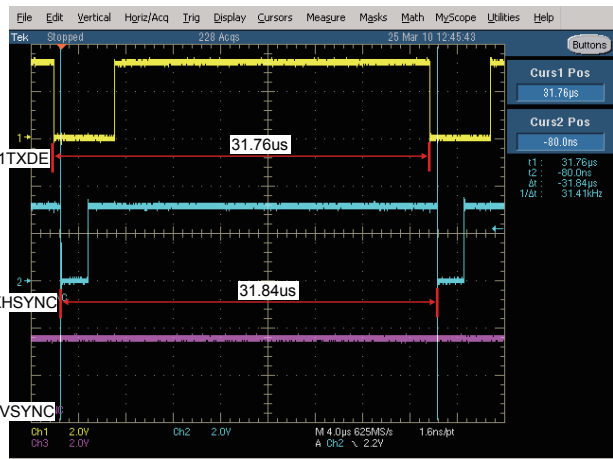
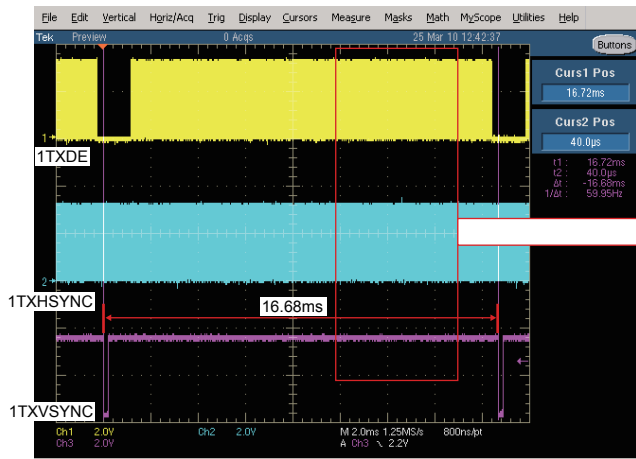

## 4. AUDIO

### 4.1. AUDIO CHECK

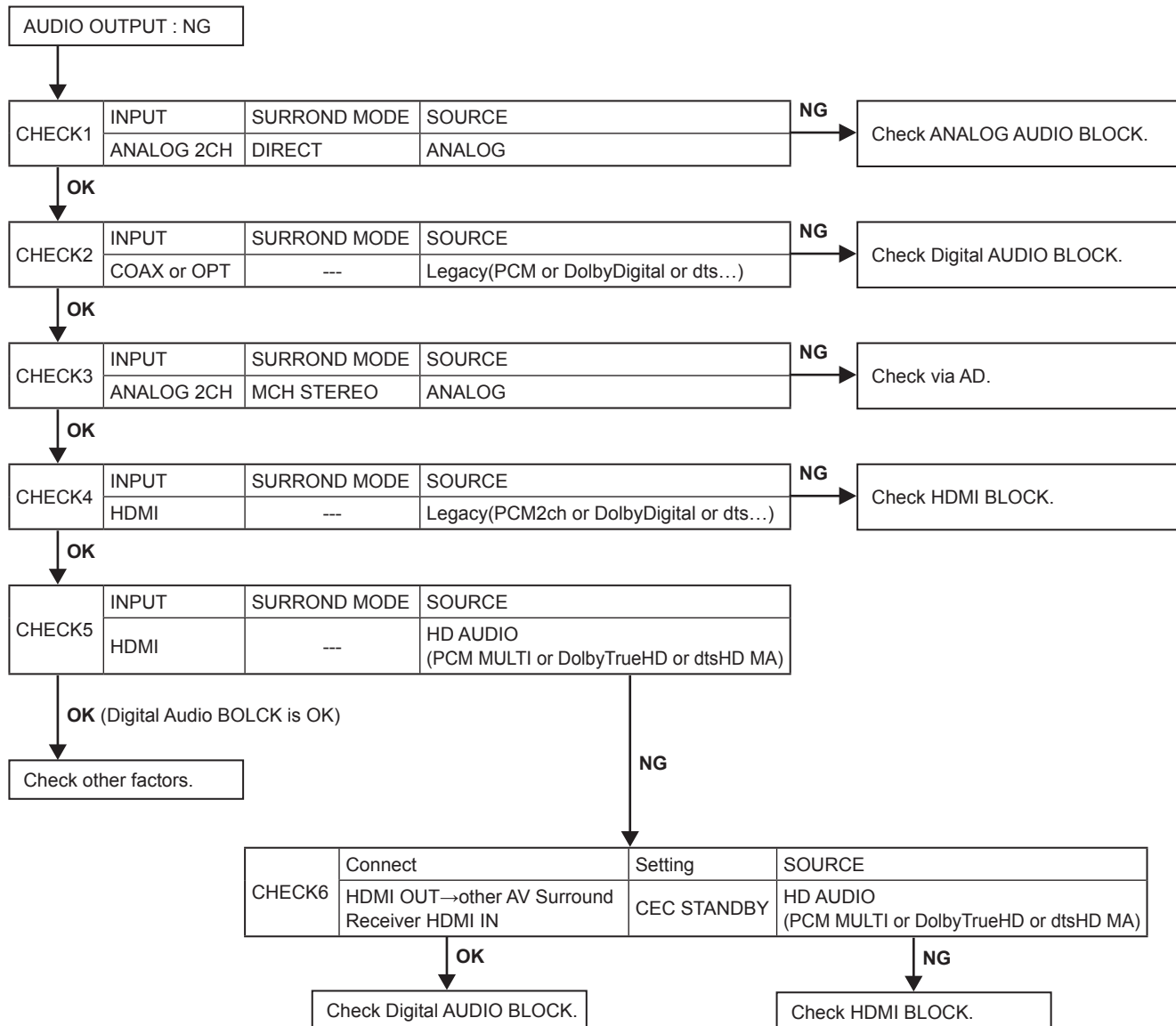

## 4.2. Power AMP (7CH AMP B'D)

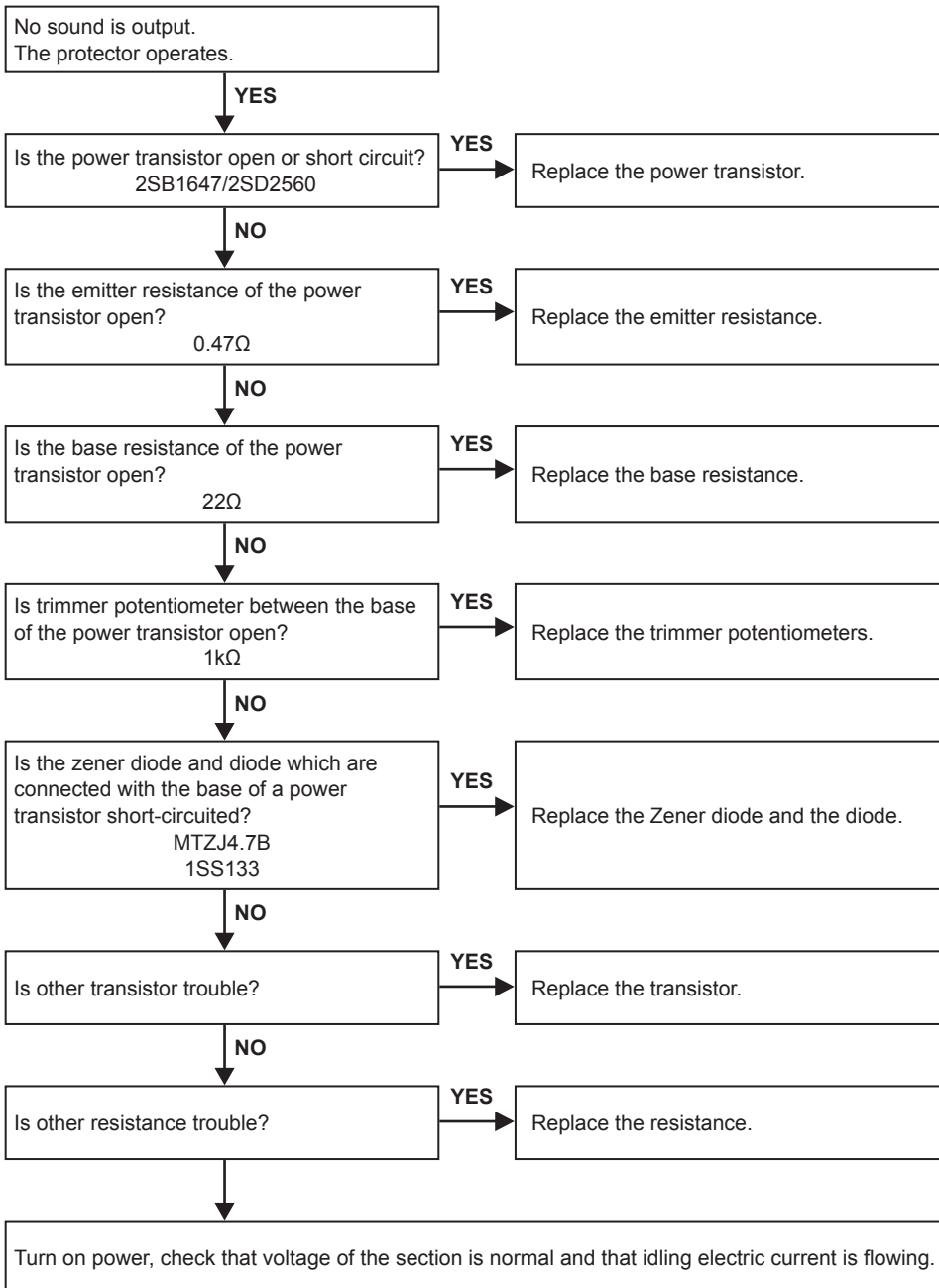

### 4.3. Analog audio

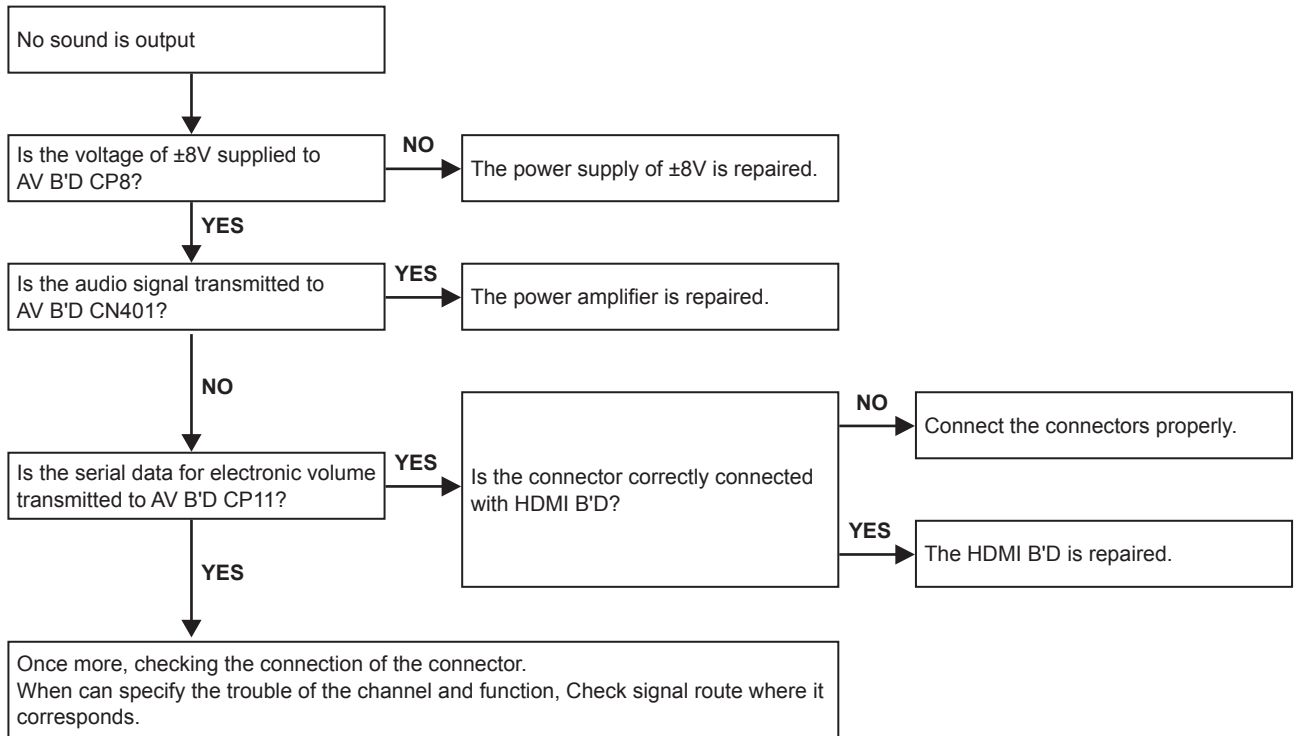





# CLOCK FLOW & WAVE FORM IN DIGITAL BLOCK

## Wave form

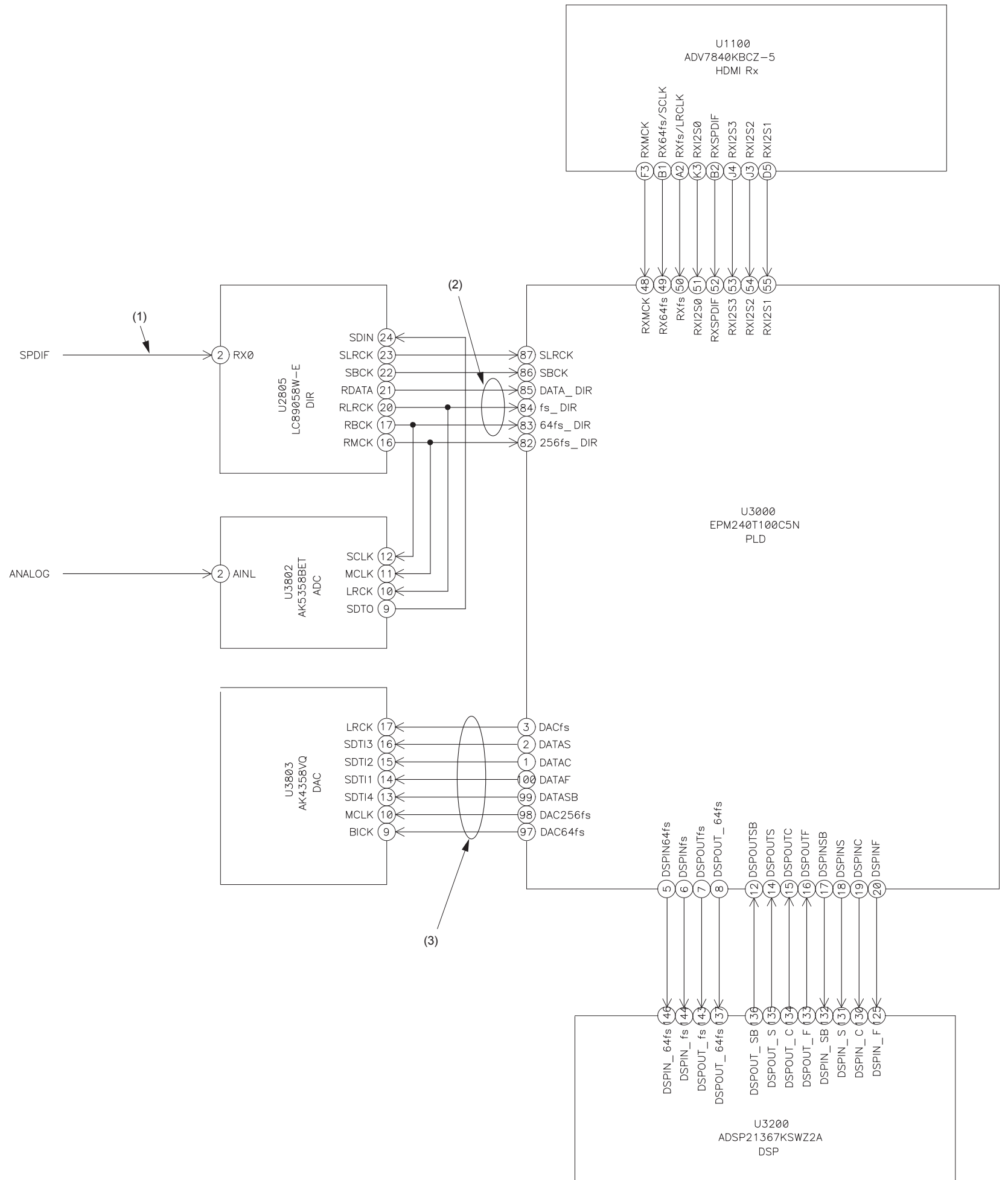
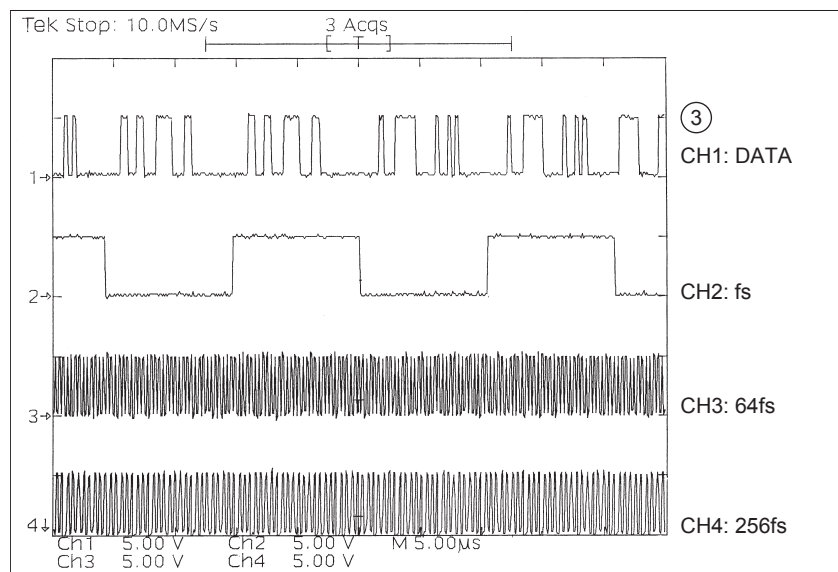
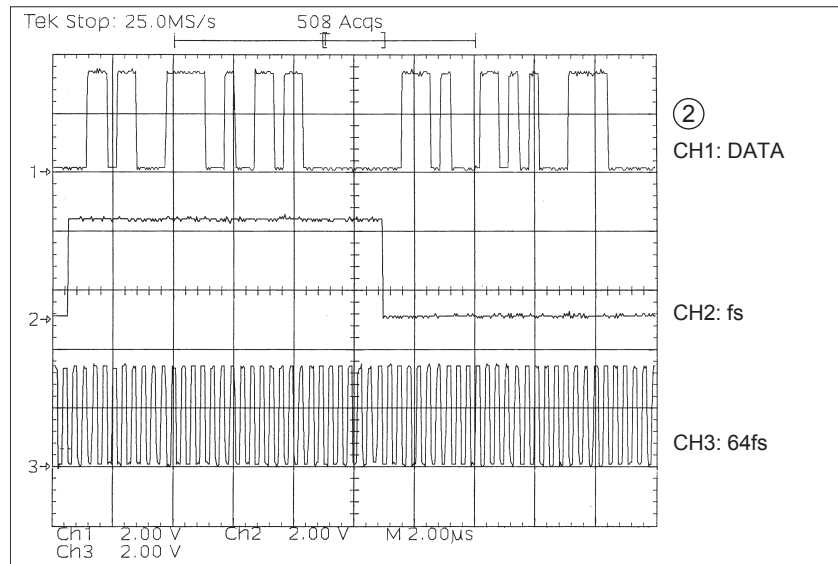
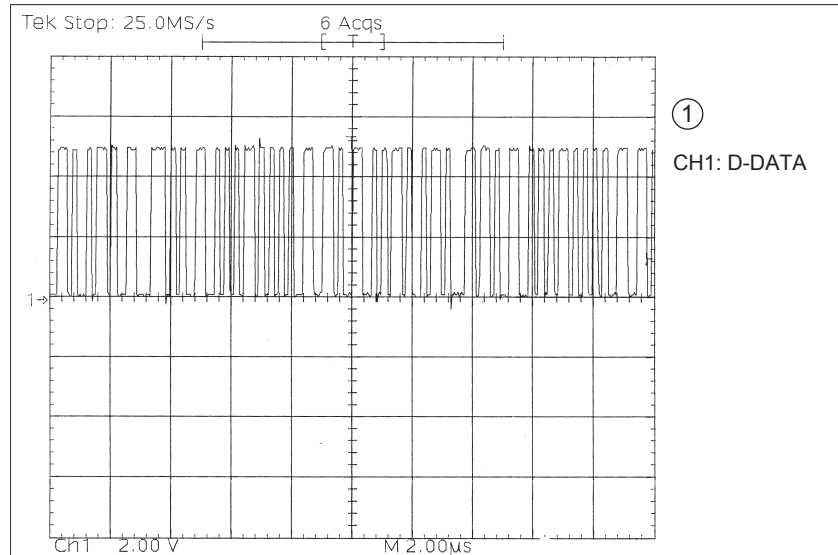

# BLOCK DIAGRAM

# AUDIO BLOCK DIAGRAM

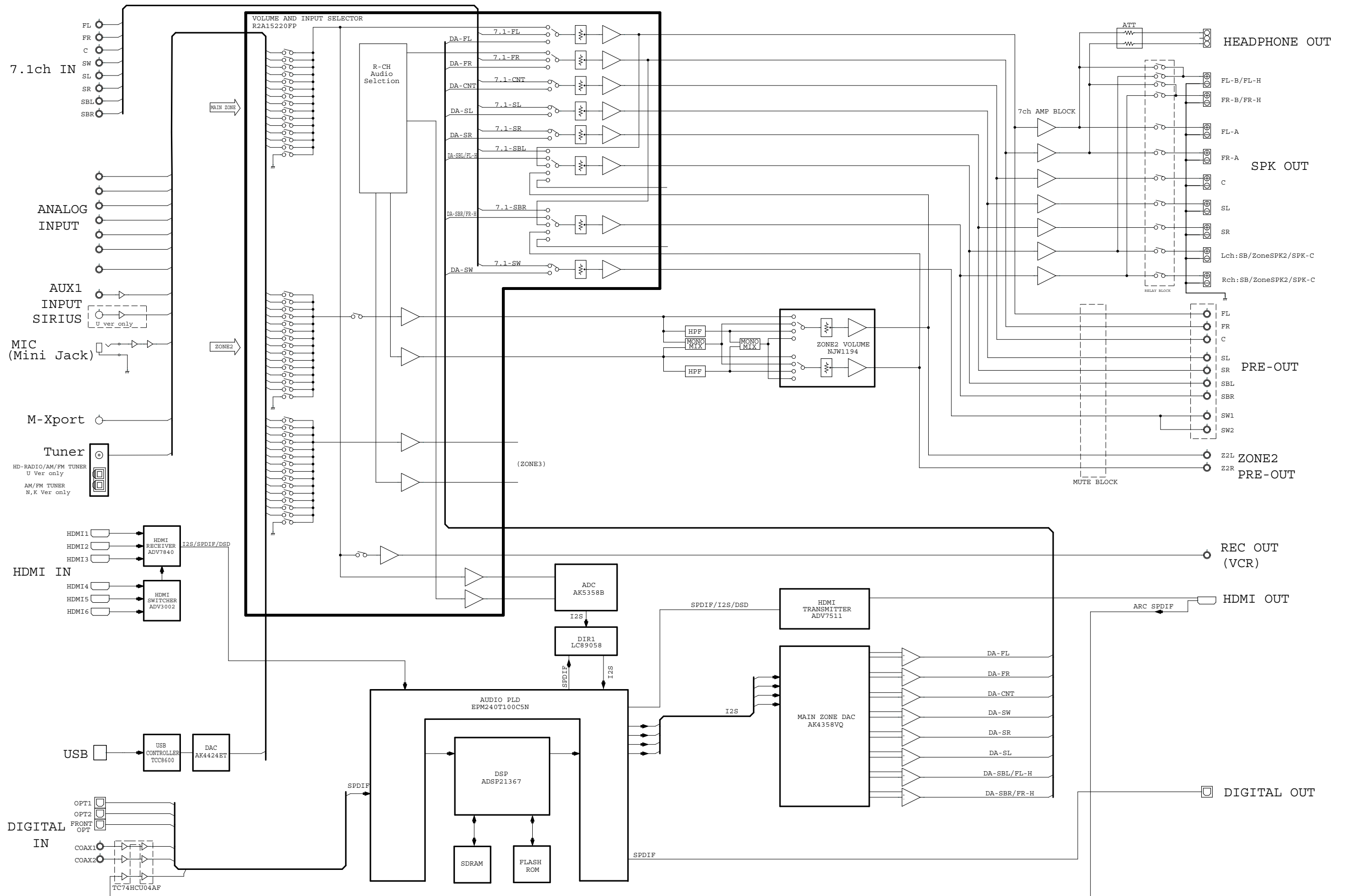

VIDEO BLOCK DIAGRAM

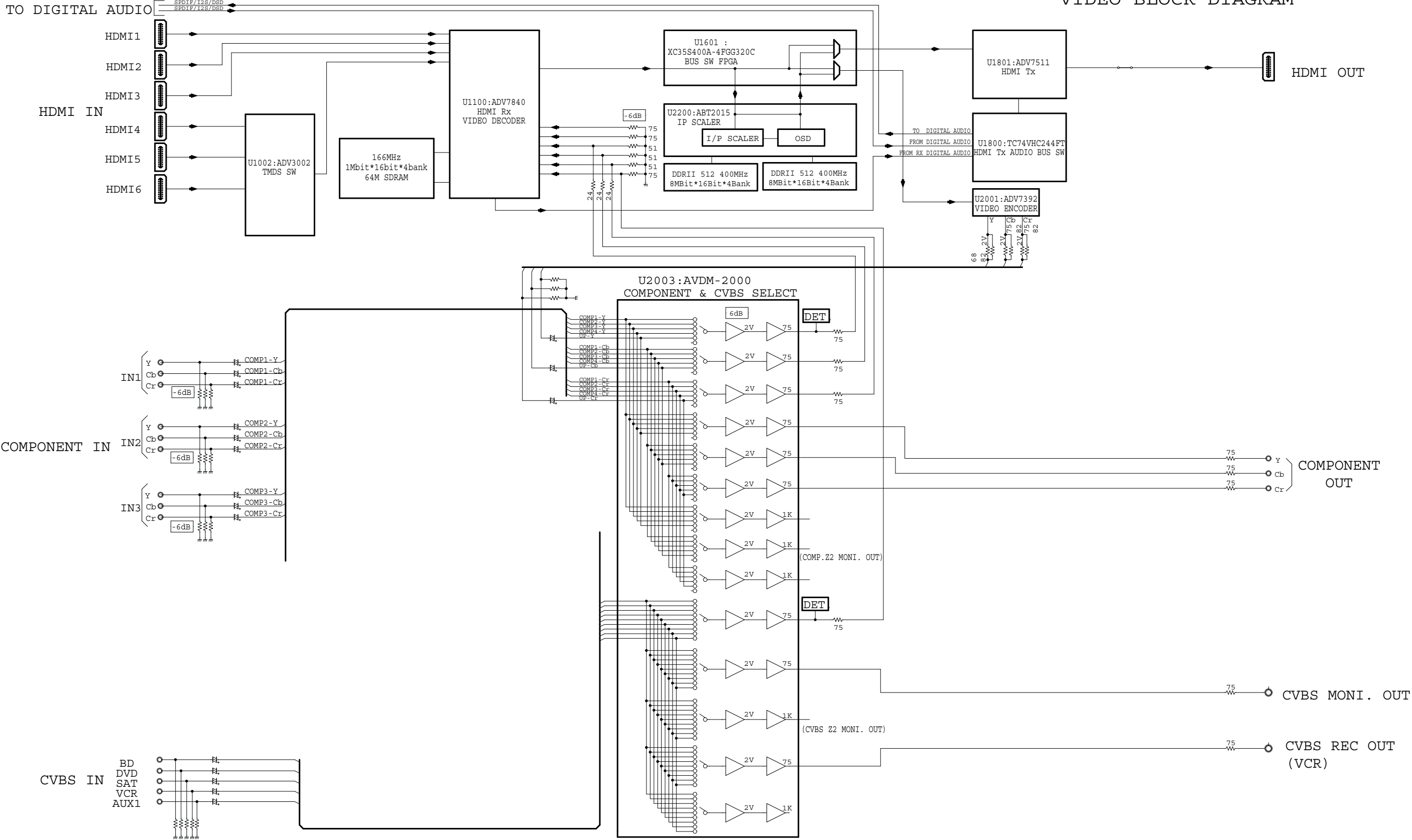

# VCC DIAGRAM

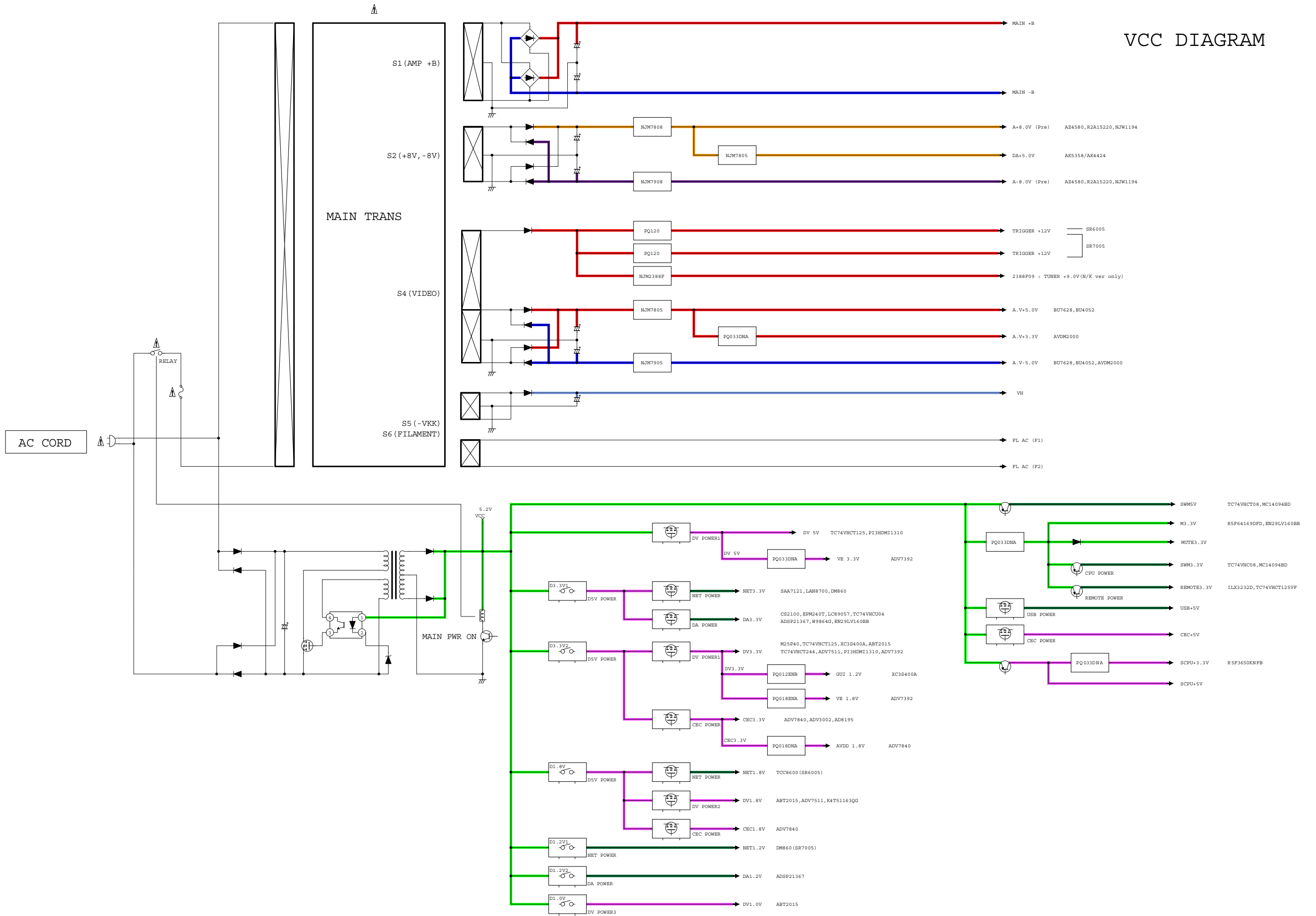

# LEVEL DIAGRAM

## LEVEL DIAGRAM FRONT ch

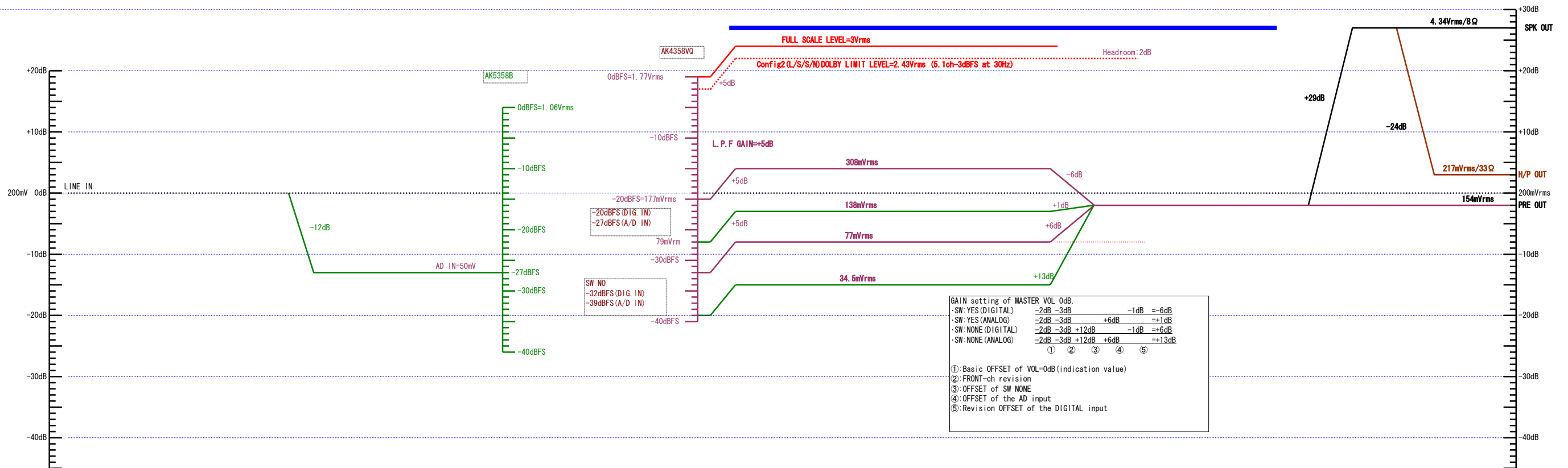
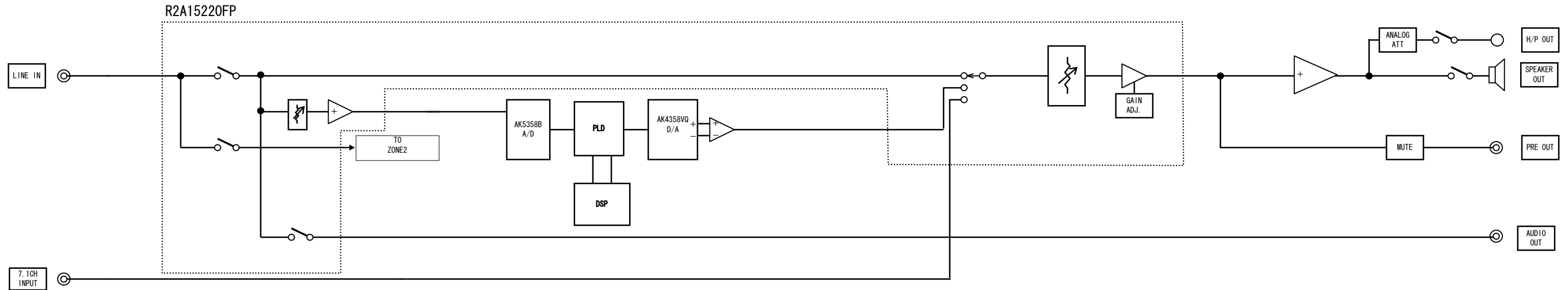

**LEVEL DIAGRAM**  
**CENTER ch**

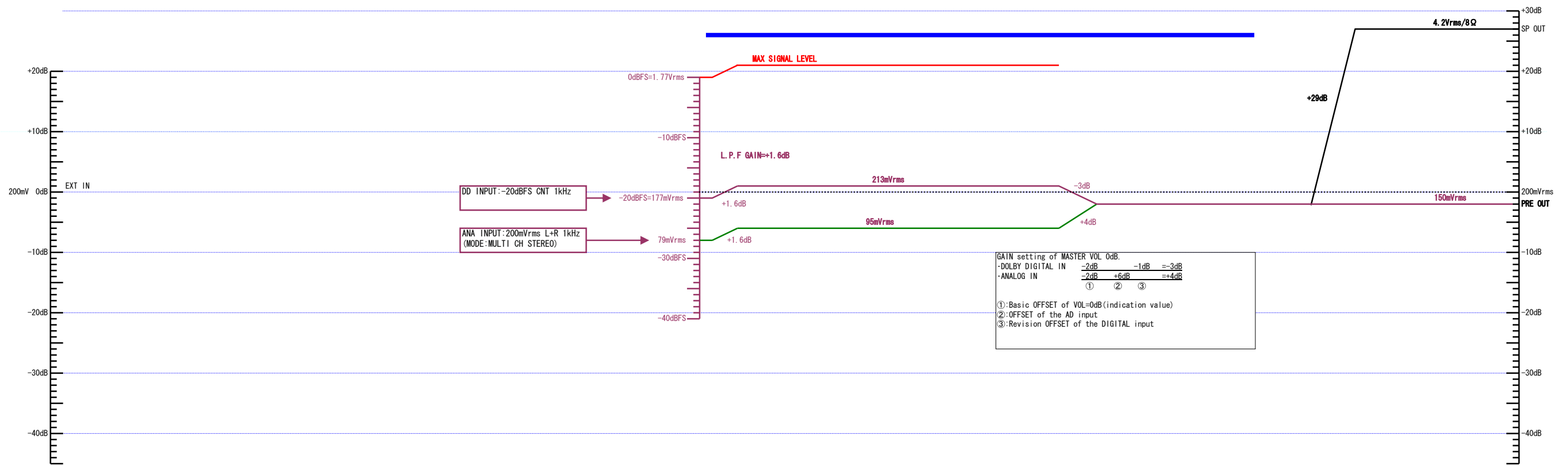
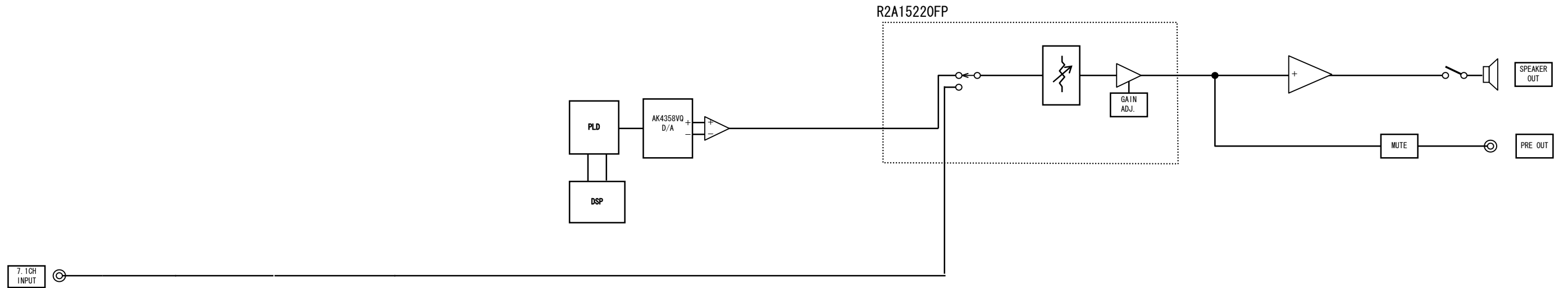

**LEVEL DIAGRAM  
SUBWOOFER ch**

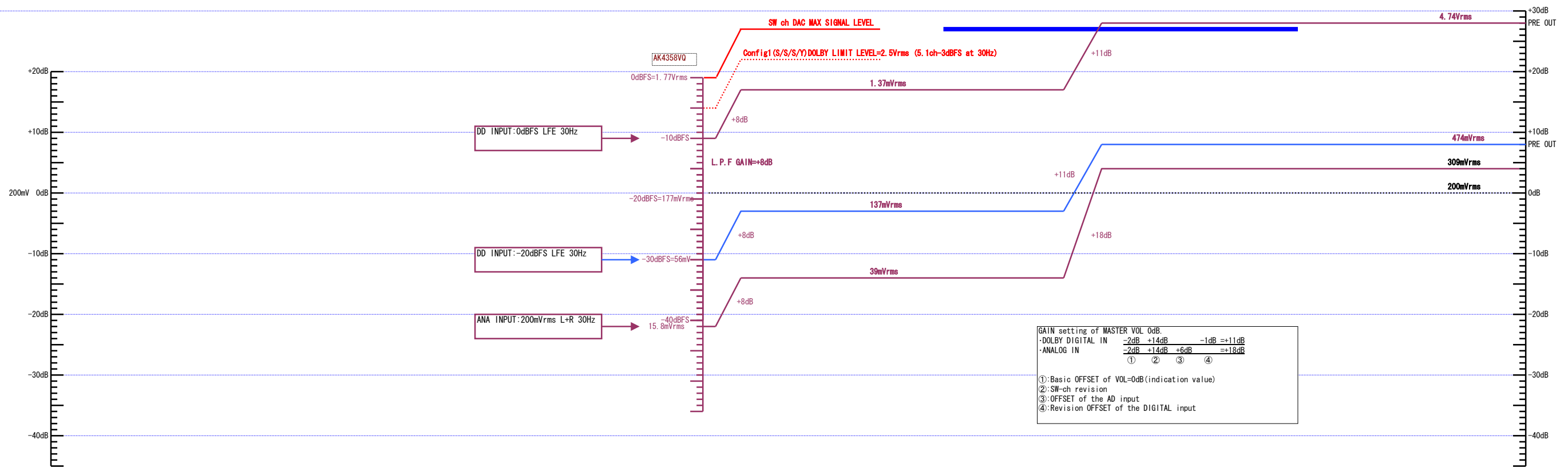
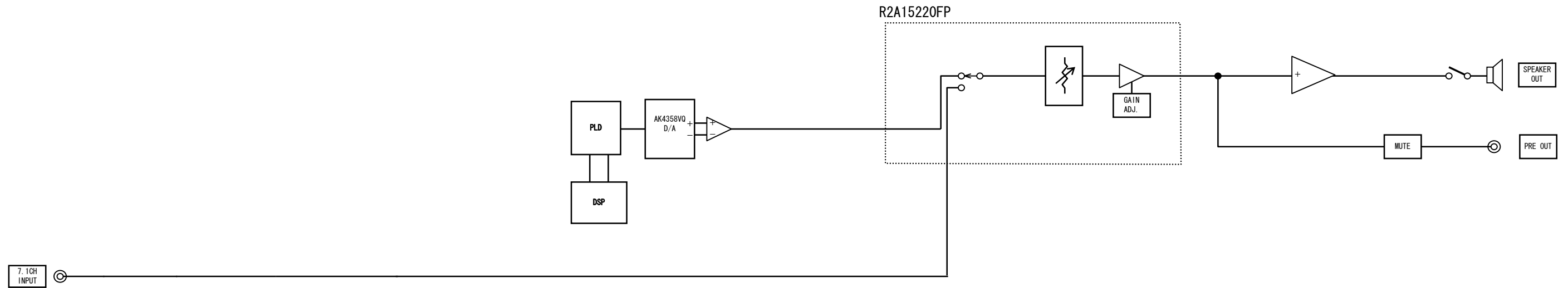

**LEVEL DIAGRAM**  
**SURROUND ch**

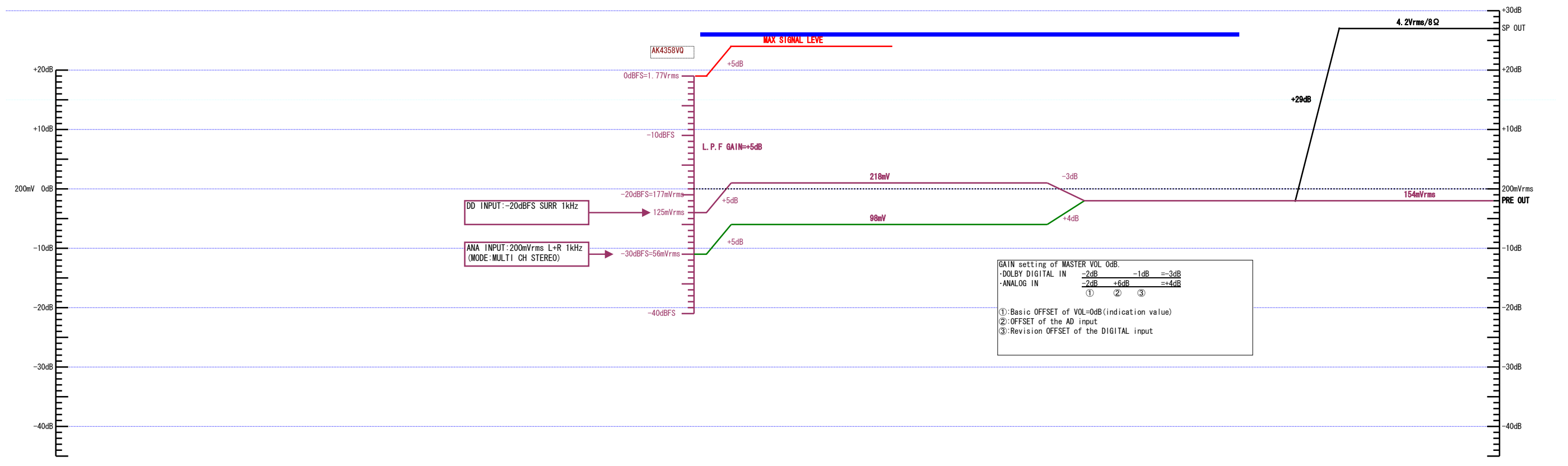
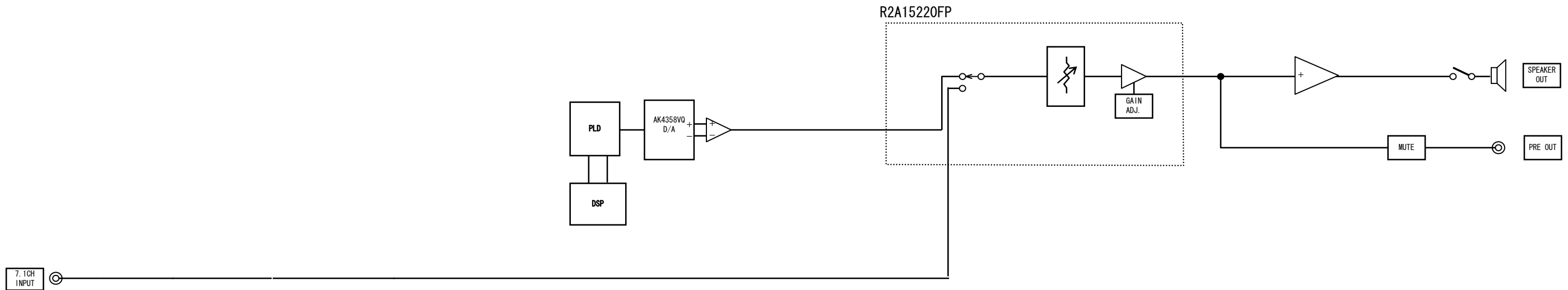



**LEVEL DIAGRAM**  
**SURR.BACK ch**

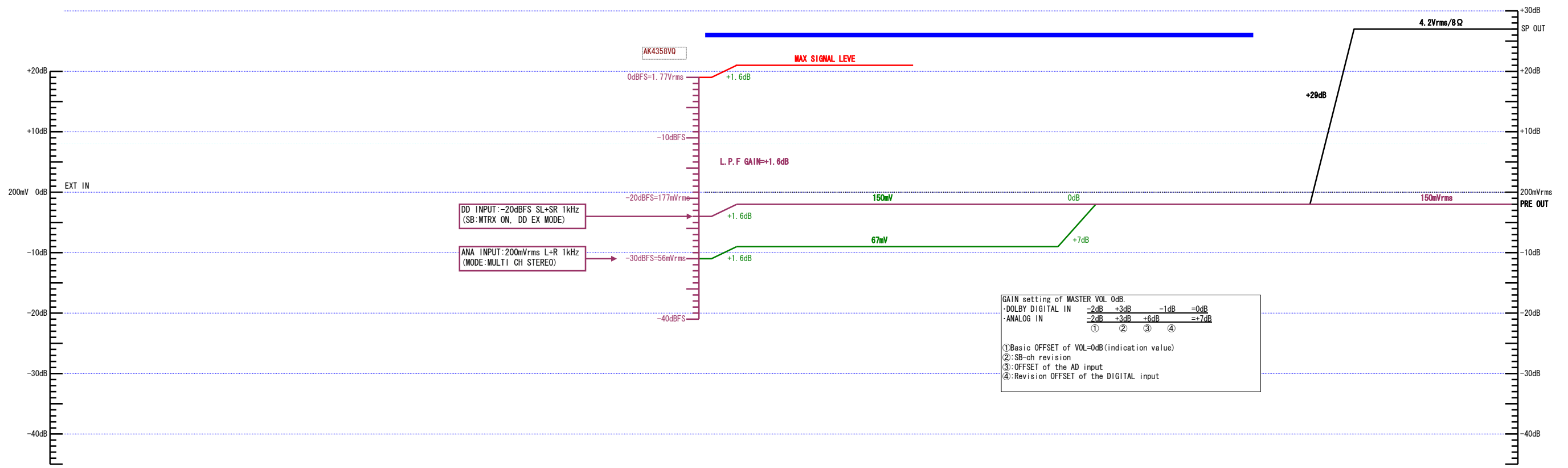
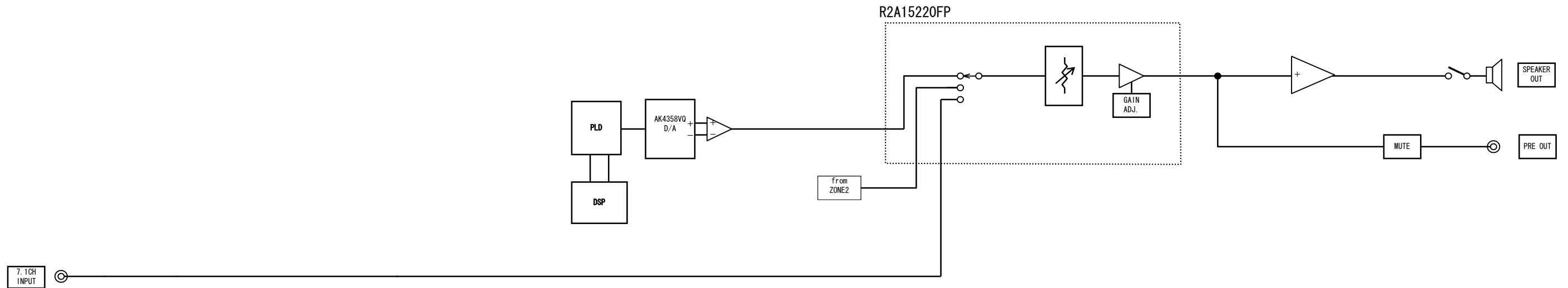

**LEVEL DIAGRAM**  
**ZONE ch**

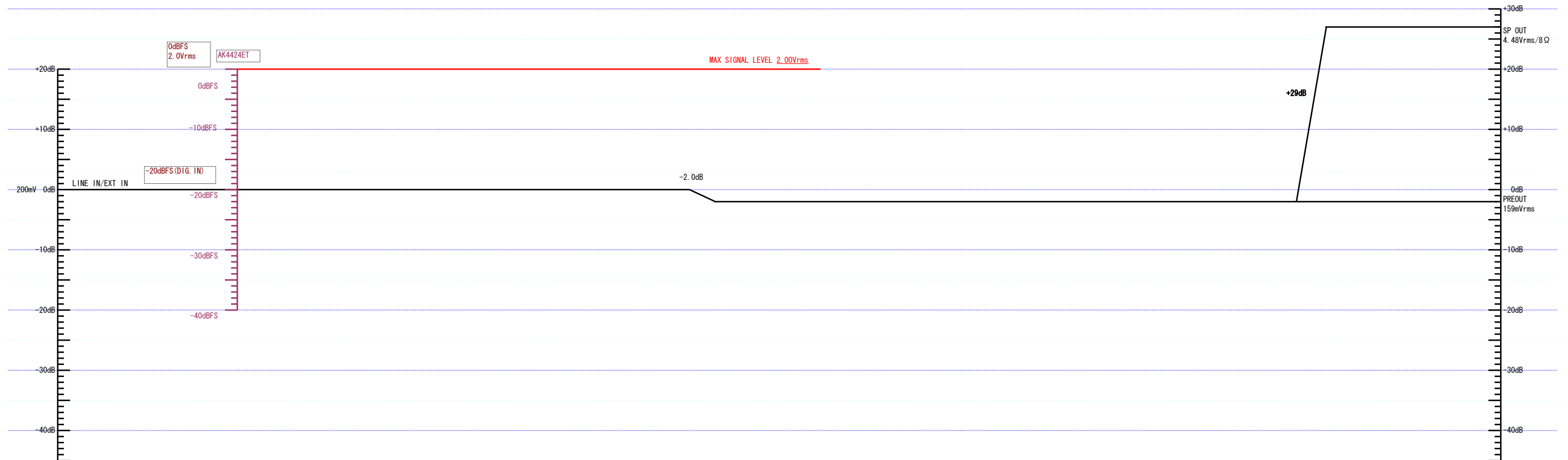
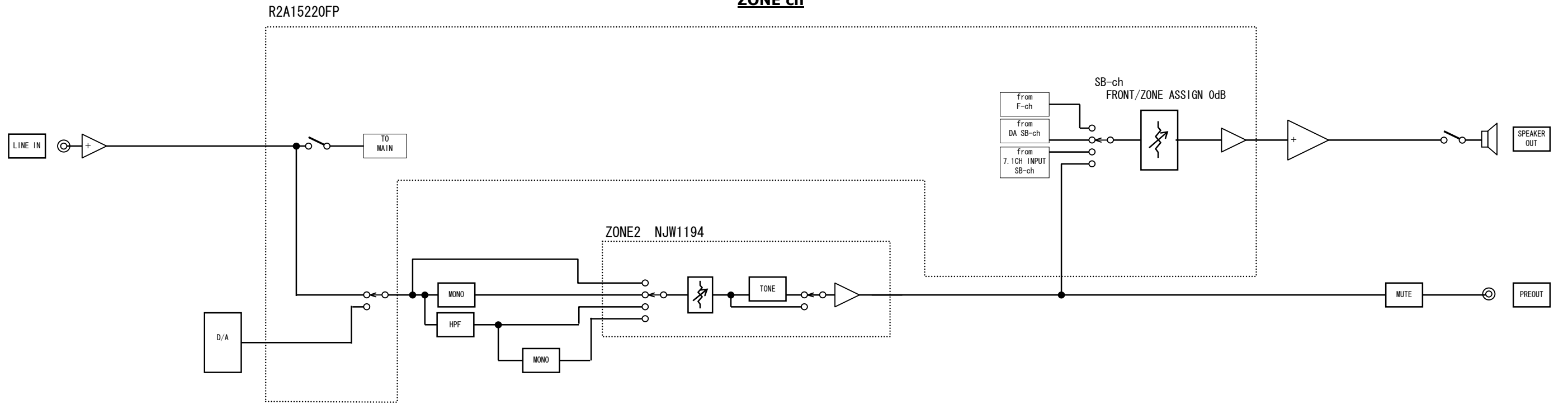

# PRINTED WIRING BOARDS

7CH-AMP (COMPONENT SIDE)

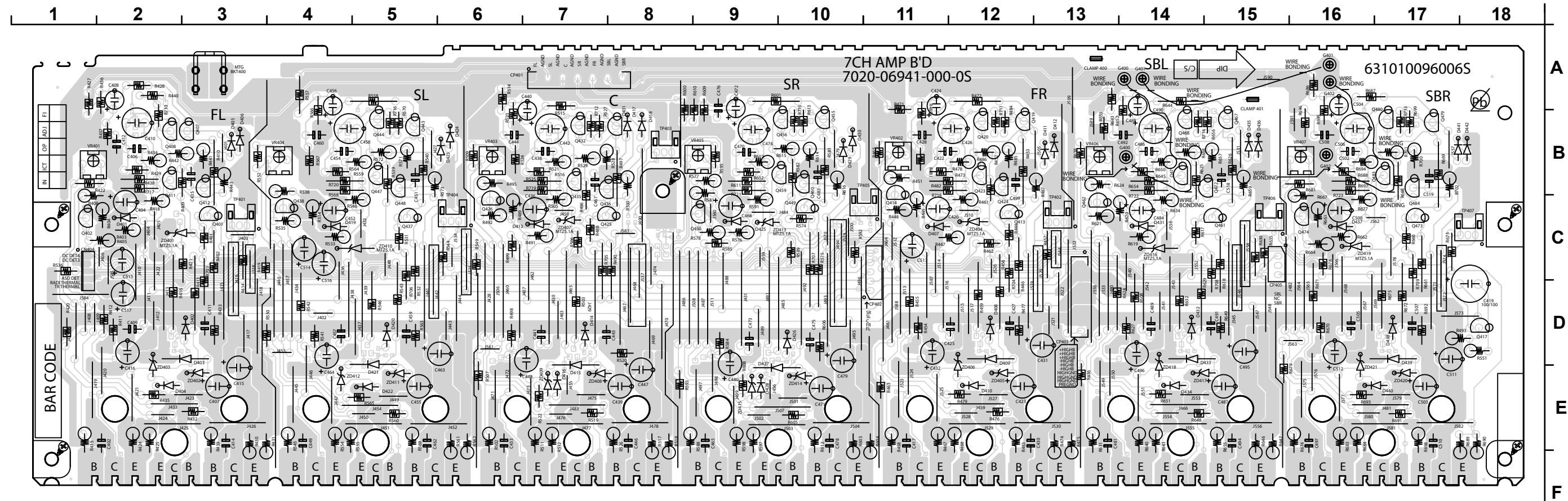

7CH-AMP (FOIL SIDE)

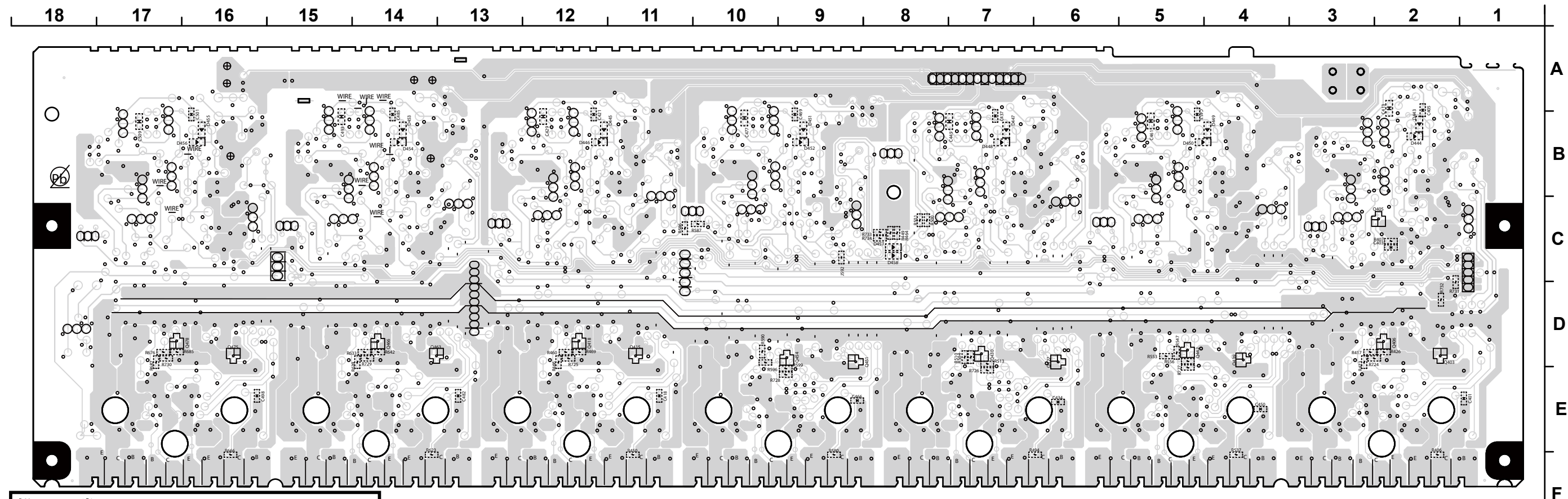

**鉛フリー半田**  
半田付けには、鉛フリー半田 (Sn-Ag-Cu) を使用してください。

**Lead-free Solder**  
When soldering, use the Lead-free Solder (Sn-Ag-Cu).

SMPS (COMPONENT SIDE)

1 2 3 4 5 6 7 8 9 10 11 12

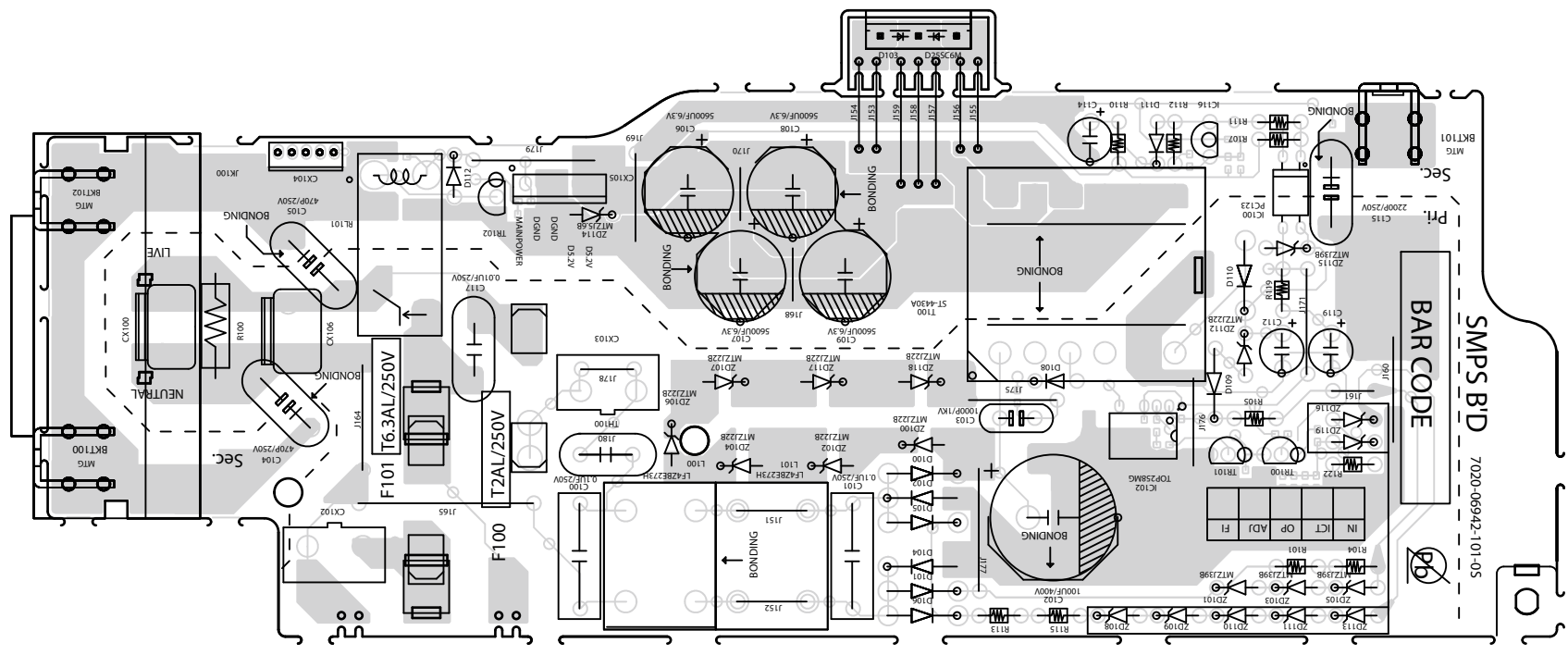

A  
B  
C  
D  
E  
F

SMPS (FOIL SIDE)

12 11 10 9 8 7 6 5 4 3 2 1

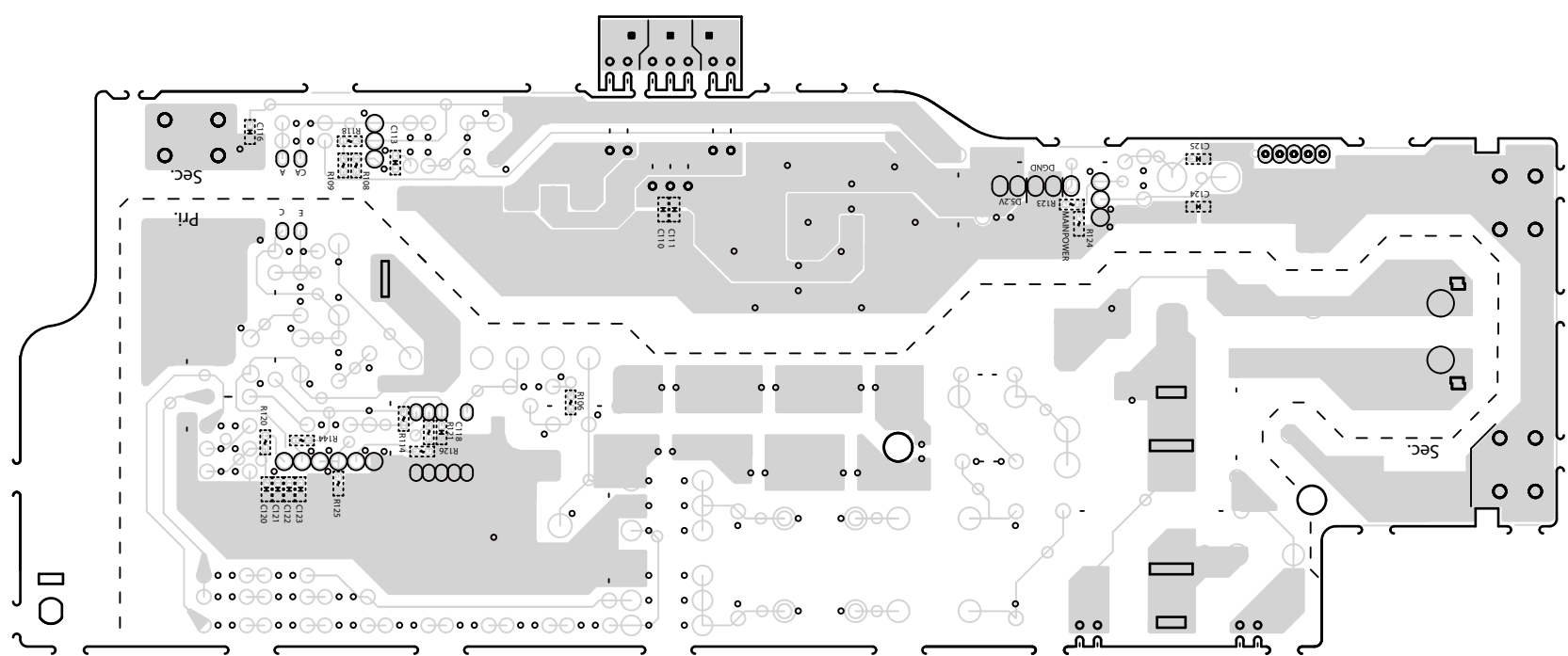

A  
B  
C  
D  
E  
F

**鉛フリー半田**  
半田付けには、鉛フリー半田 (Sn-Ag-Cu) を使用してください。

**Lead-free Solder**  
When soldering, use the Lead-free Solder (Sn-Ag-Cu).

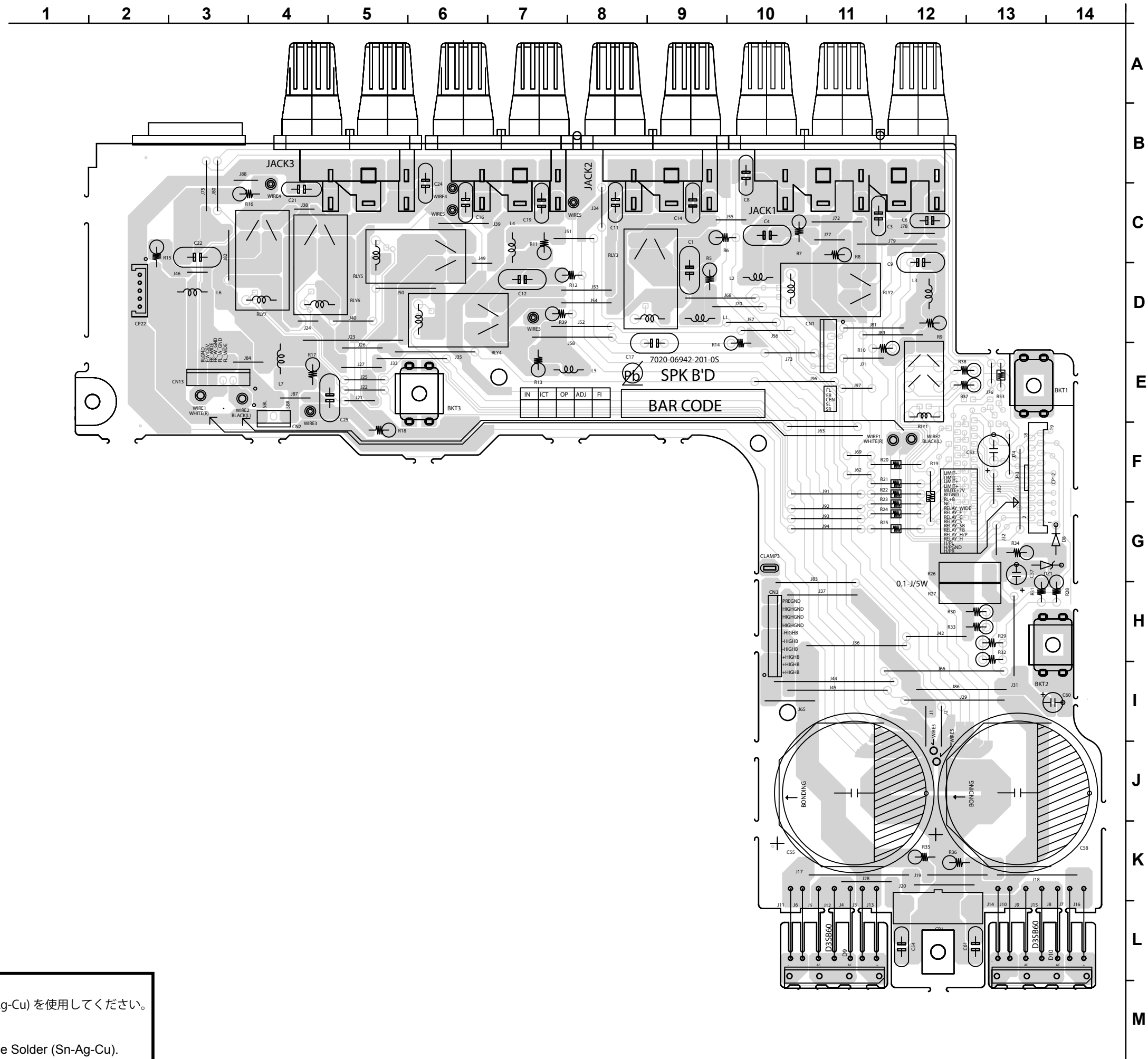

**鉛フリー半田**

半田付けには、鉛フリー半田 (Sn-Ag-Cu) を使用してください。

**Lead-free Solder**

When soldering, use the Lead-free Solder (Sn-Ag-Cu).

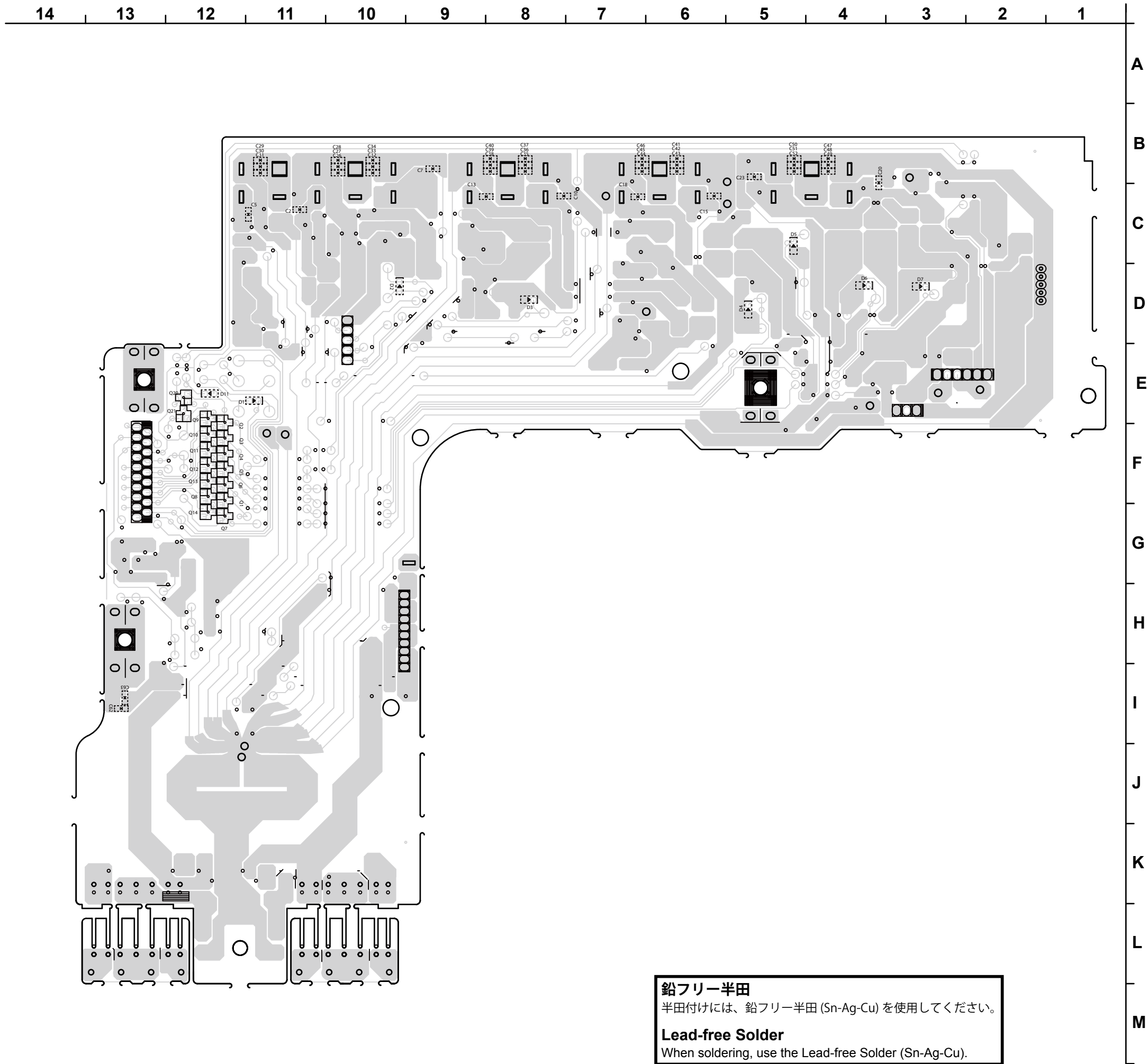

**鉛フリー半田**  
 半田付けには、鉛フリー半田 (Sn-Ag-Cu) を使用してください。

**Lead-free Solder**  
 When soldering, use the Lead-free Solder (Sn-Ag-Cu).

REG (COMPONENT SIDE)

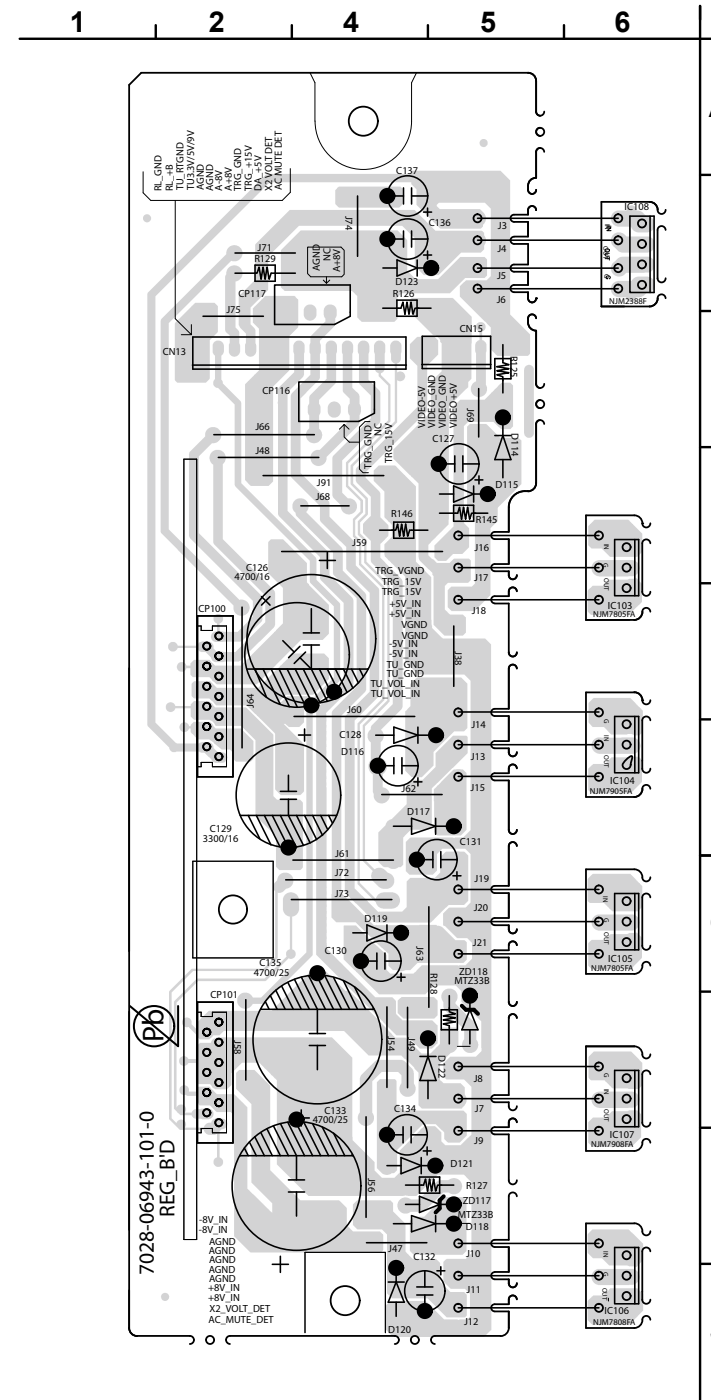

FRONT\_CNT (COMPONENT SIDE)

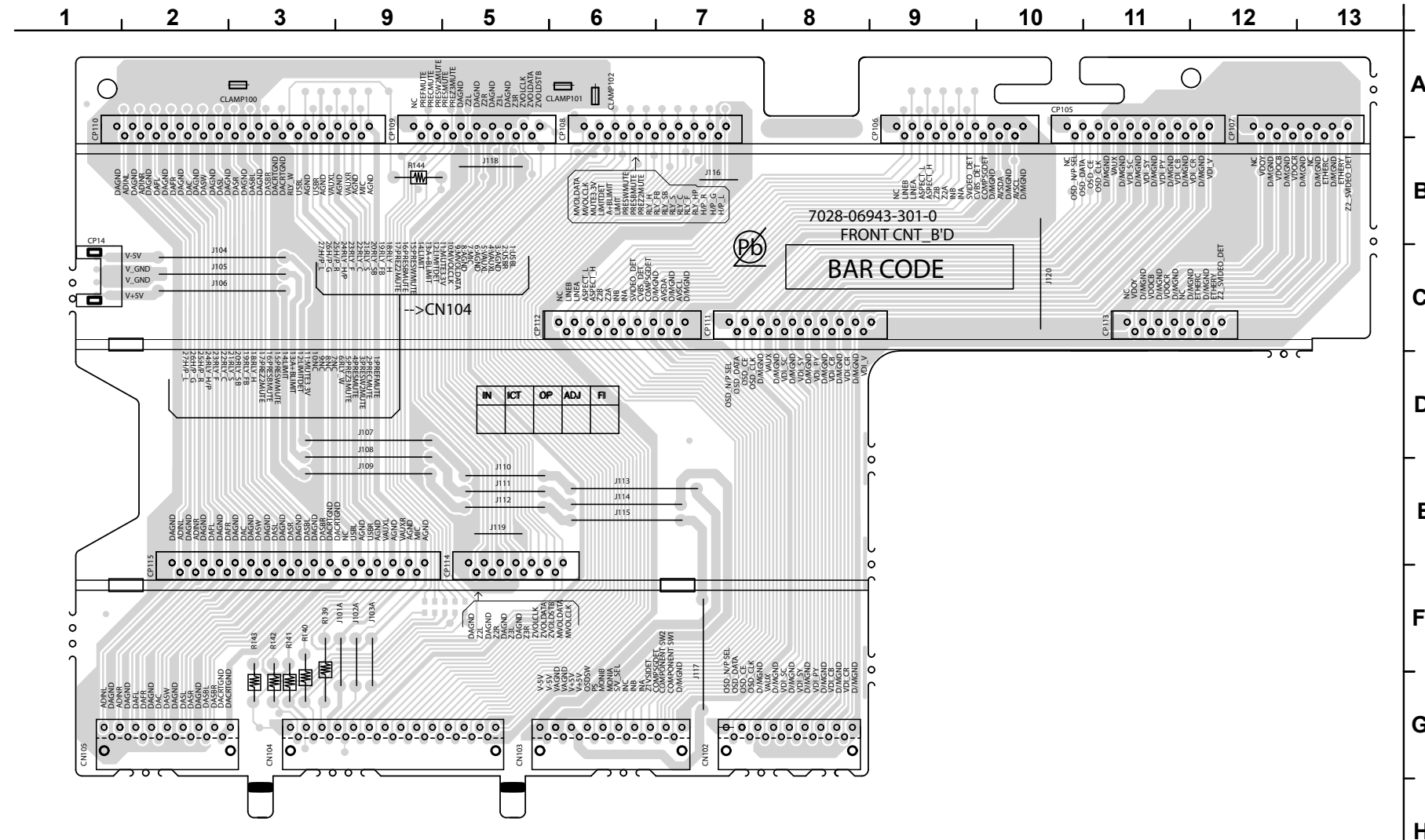

REG\_CNT (COMPONENT SIDE)

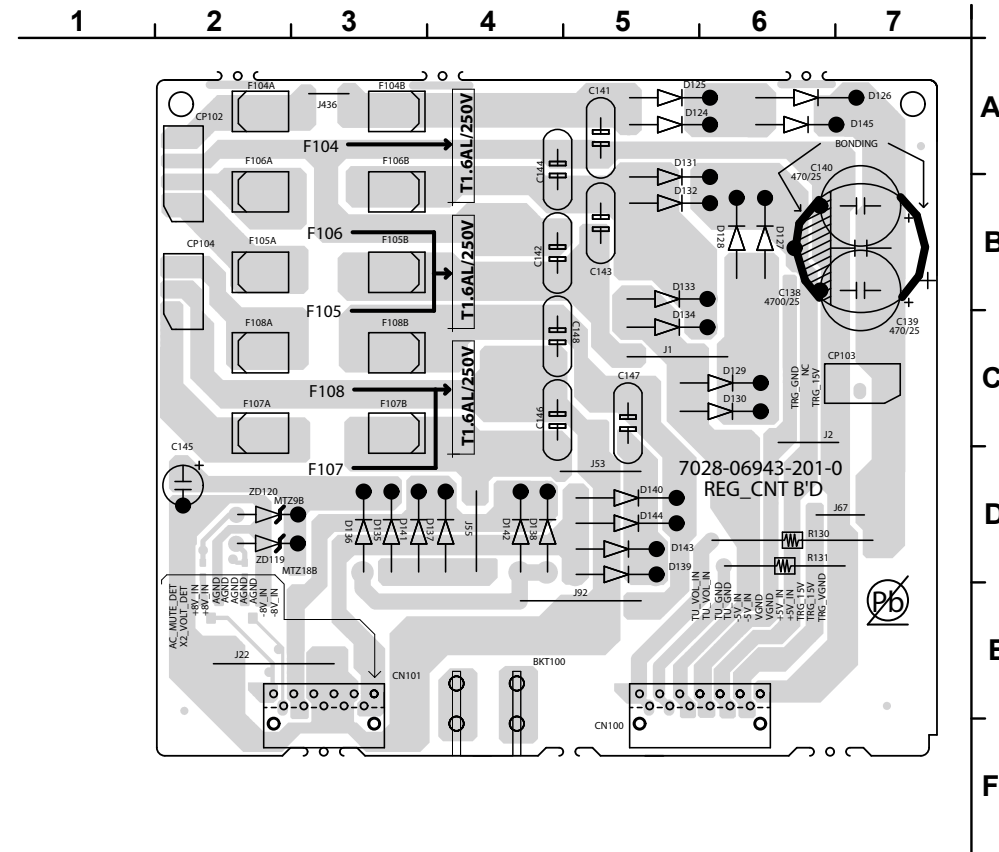

RS232C (COMPONENT SIDE)

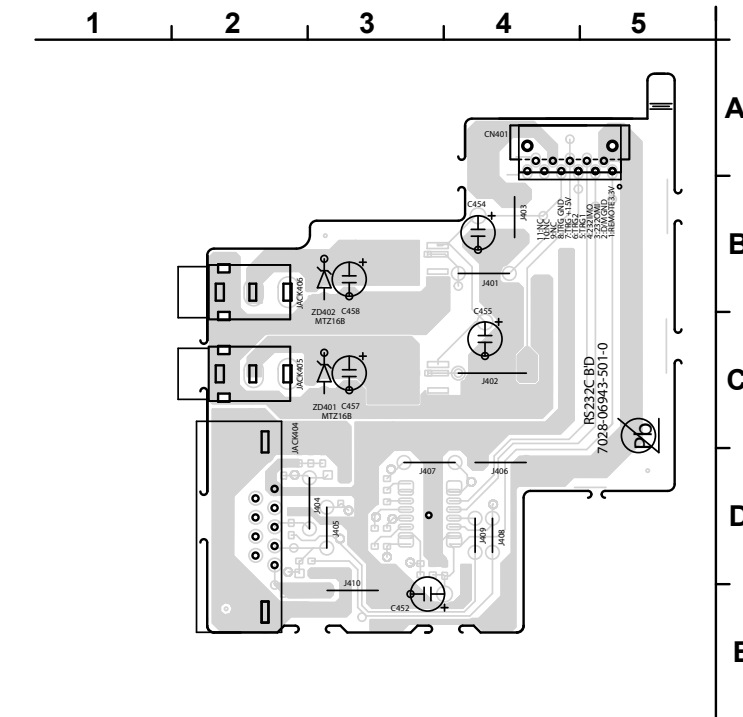

鉛フリー半田  
半田付けには、鉛フリー半田 (Sn-Ag-Cu) を使用してください。  
**Lead-free Solder**  
When soldering, use the Lead-free Solder (Sn-Ag-Cu).

REG (FOIL SIDE)

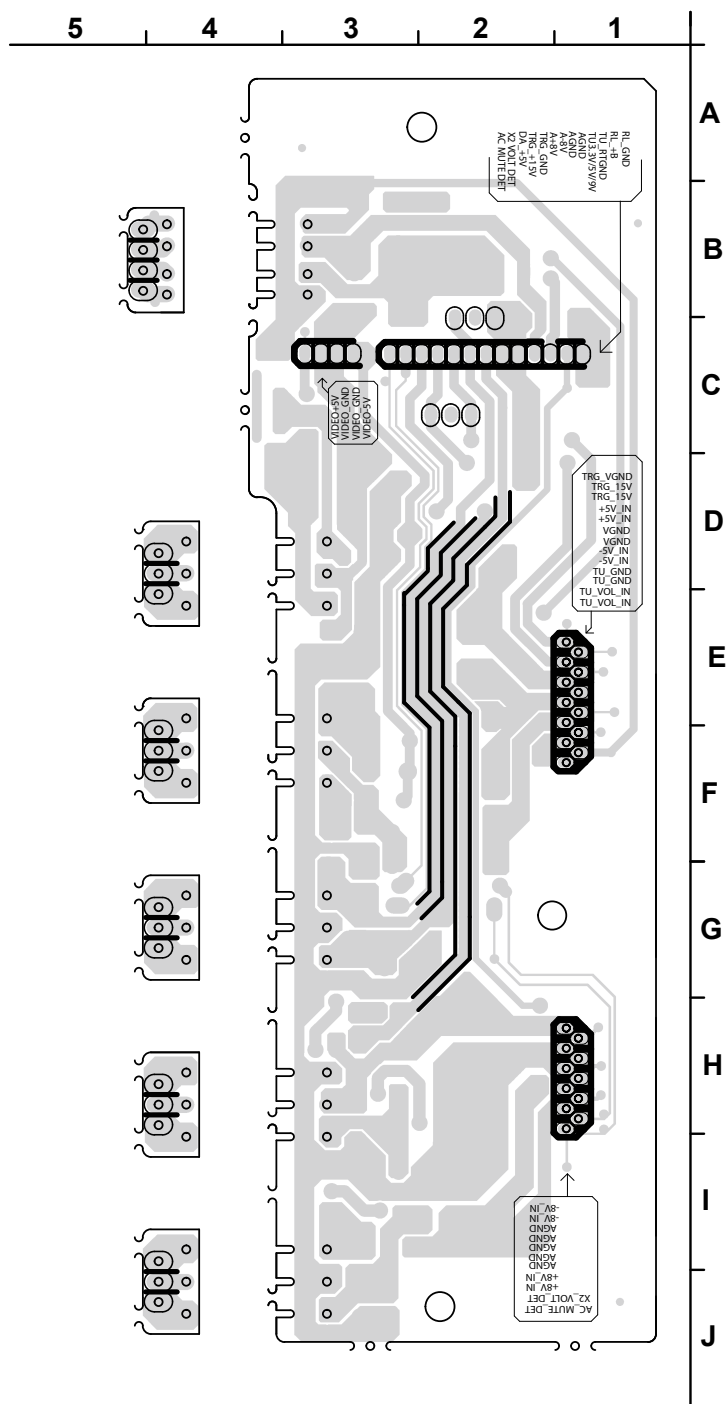

FRONT\_CNT (FOIL SIDE)

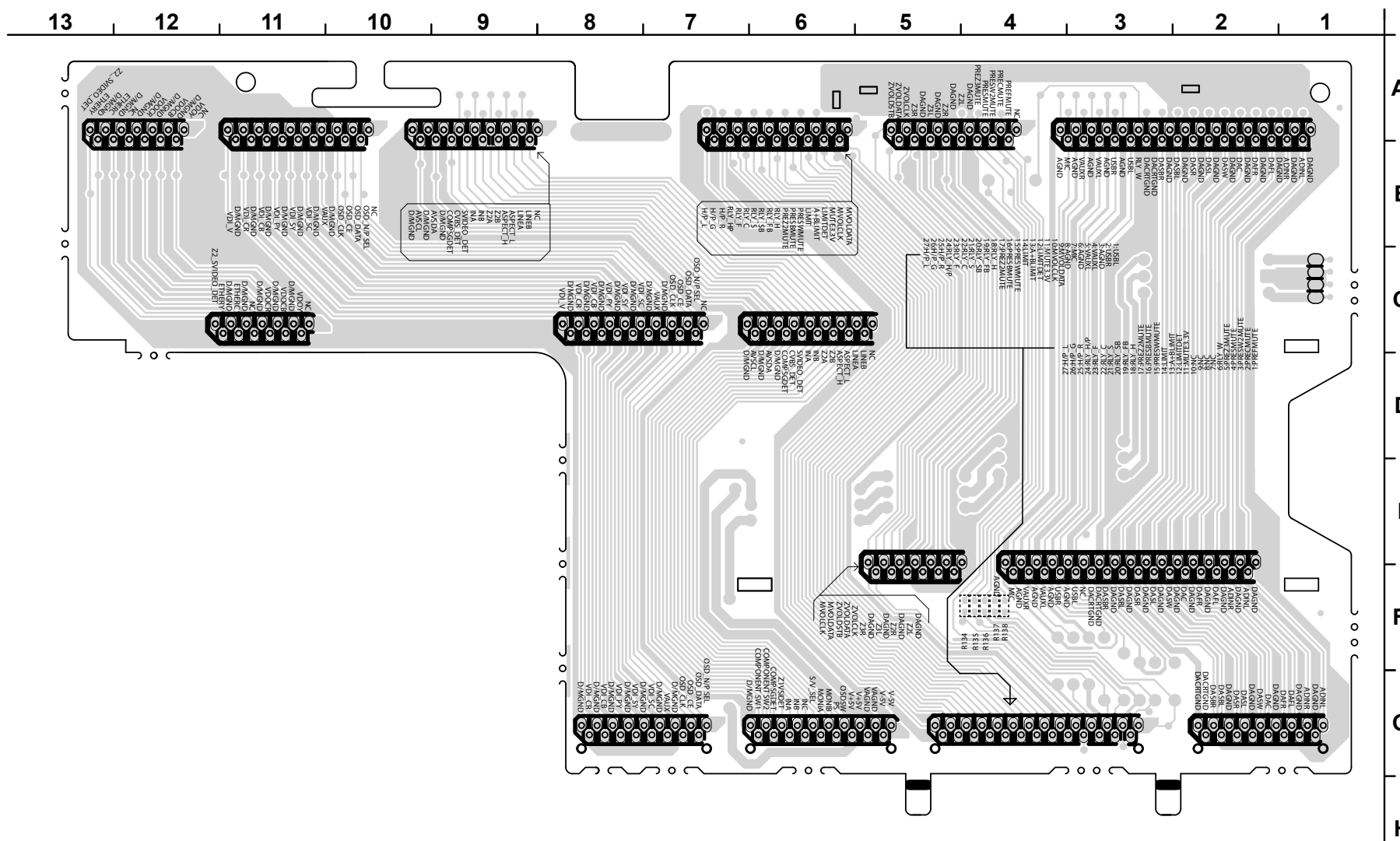

REG\_CNT (FOIL SIDE)

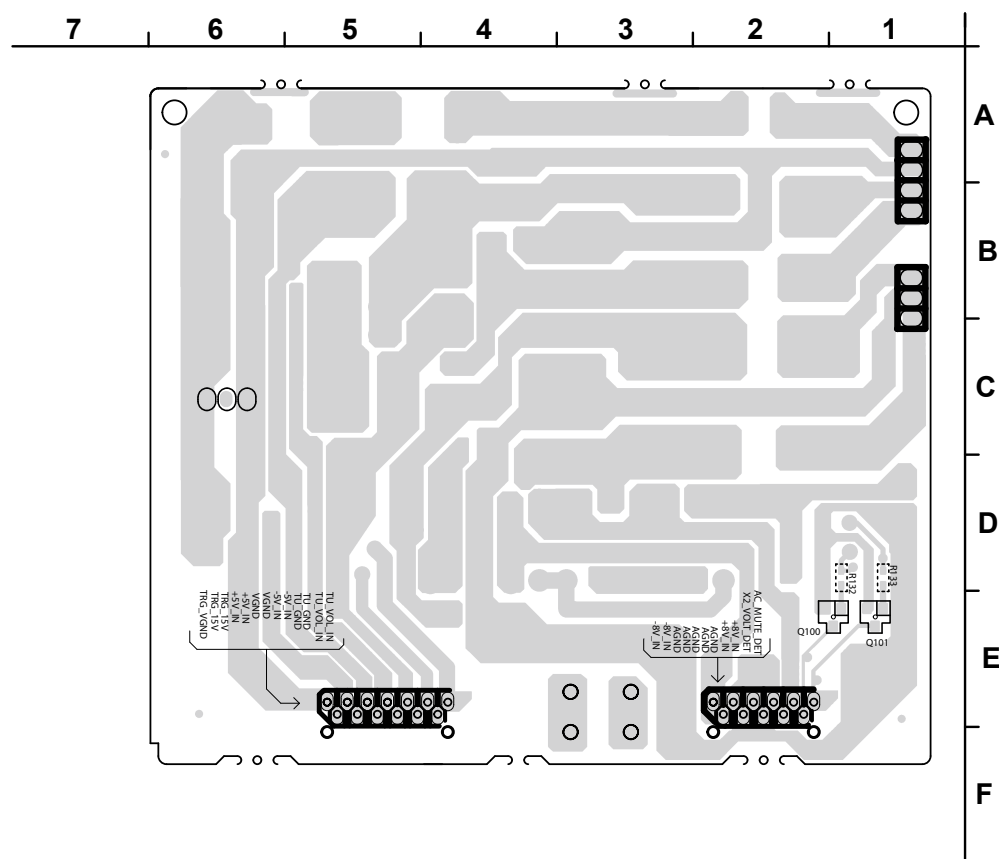

RS232C (FOIL SIDE)

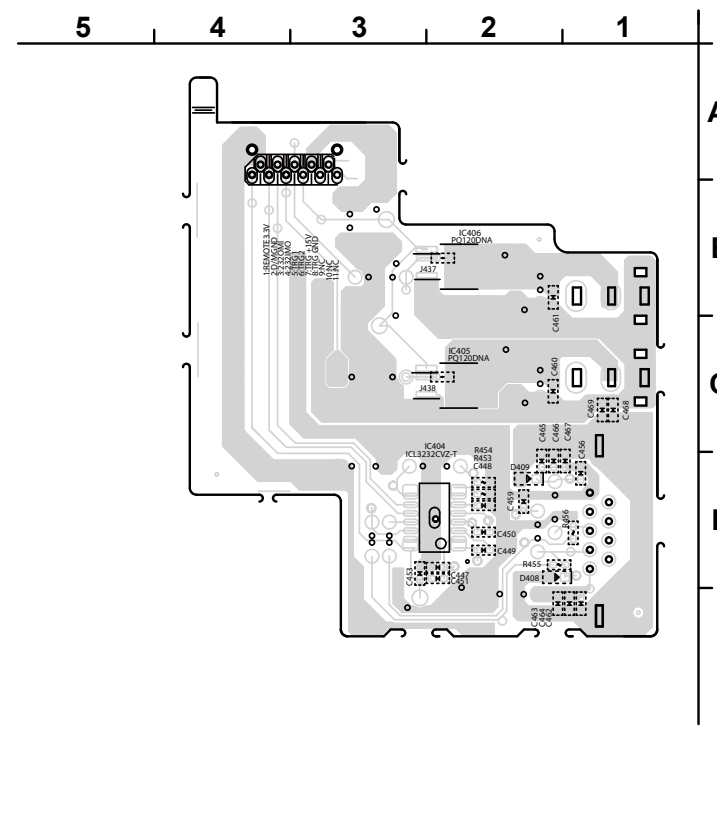

**鉛フリー半田**  
半田付けには、鉛フリー半田 (Sn-Ag-Cu) を使用してください。

**Lead-free Solder**  
When soldering, use the Lead-free Solder (Sn-Ag-Cu).



SIDE\_CNT (COMPONENT SIDE)

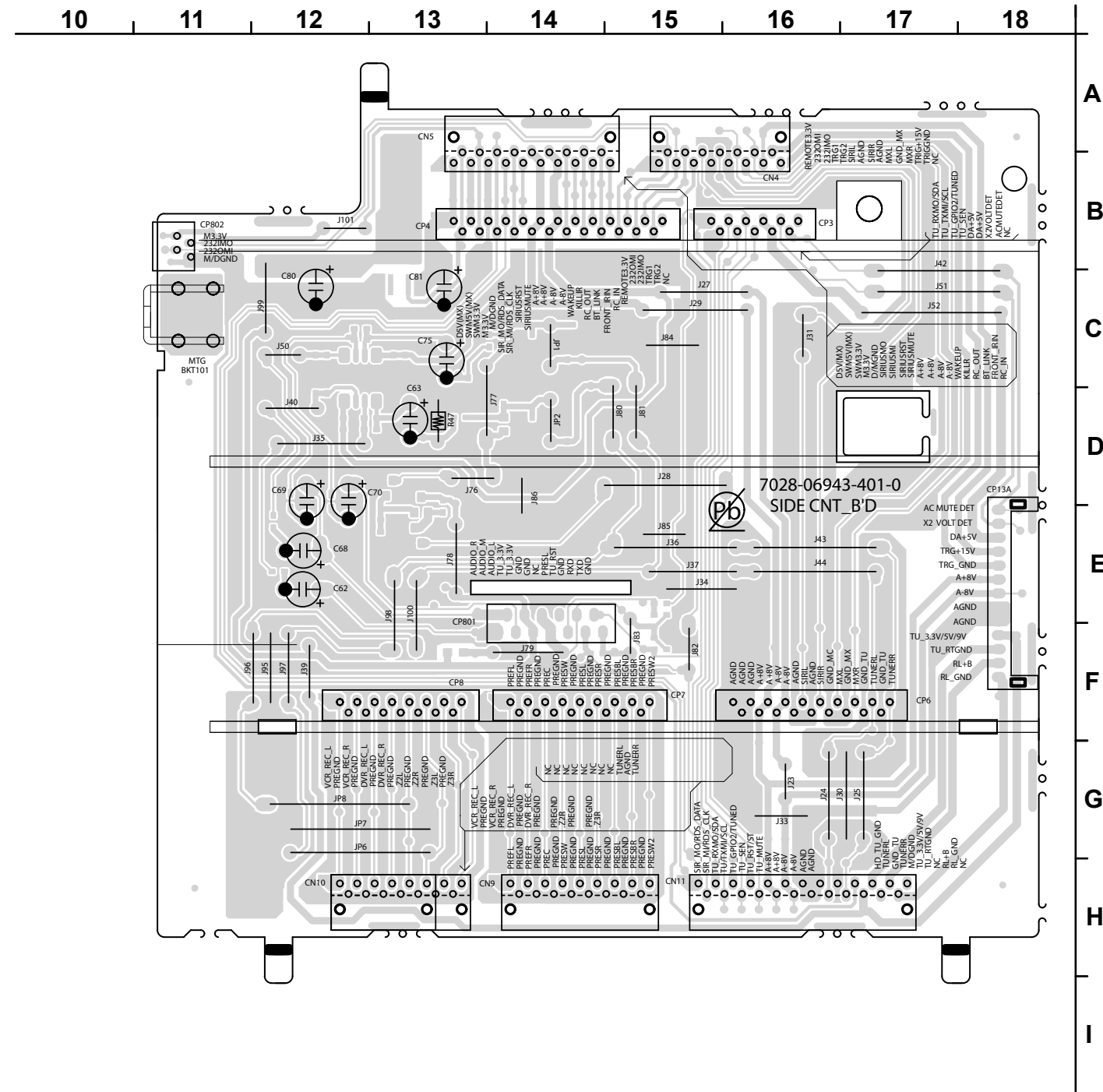

SIRIUS (COMPONENT SIDE)

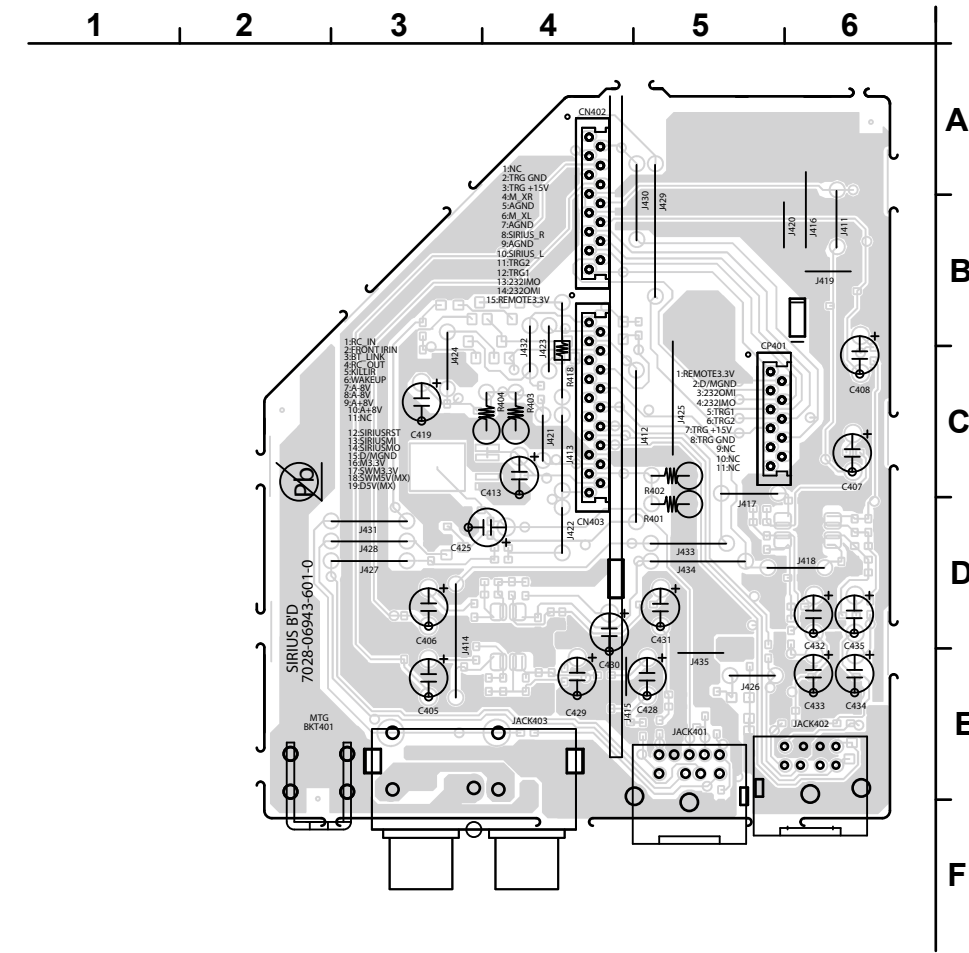

USB (COMPONENT SIDE)

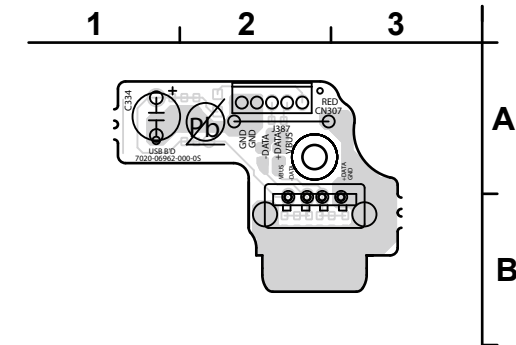

鉛フリー半田

半田付けには、鉛フリー半田 (Sn-Ag-Cu) を使用してください。

Lead-free Solder

When soldering, use the Lead-free Solder (Sn-Ag-Cu).

SIDE\_CNT (FOIL SIDE)

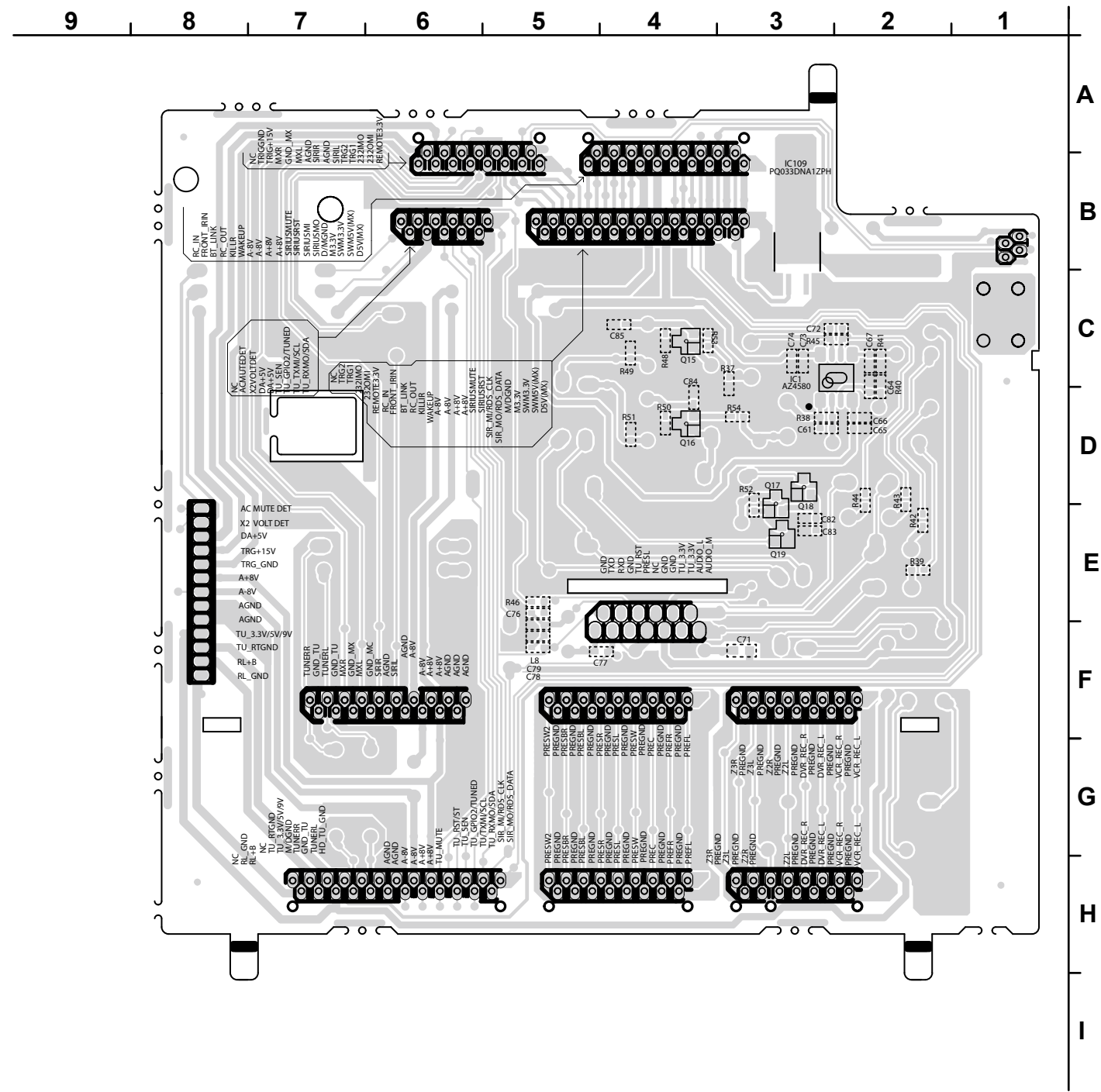

SIRIUS (FOIL SIDE)

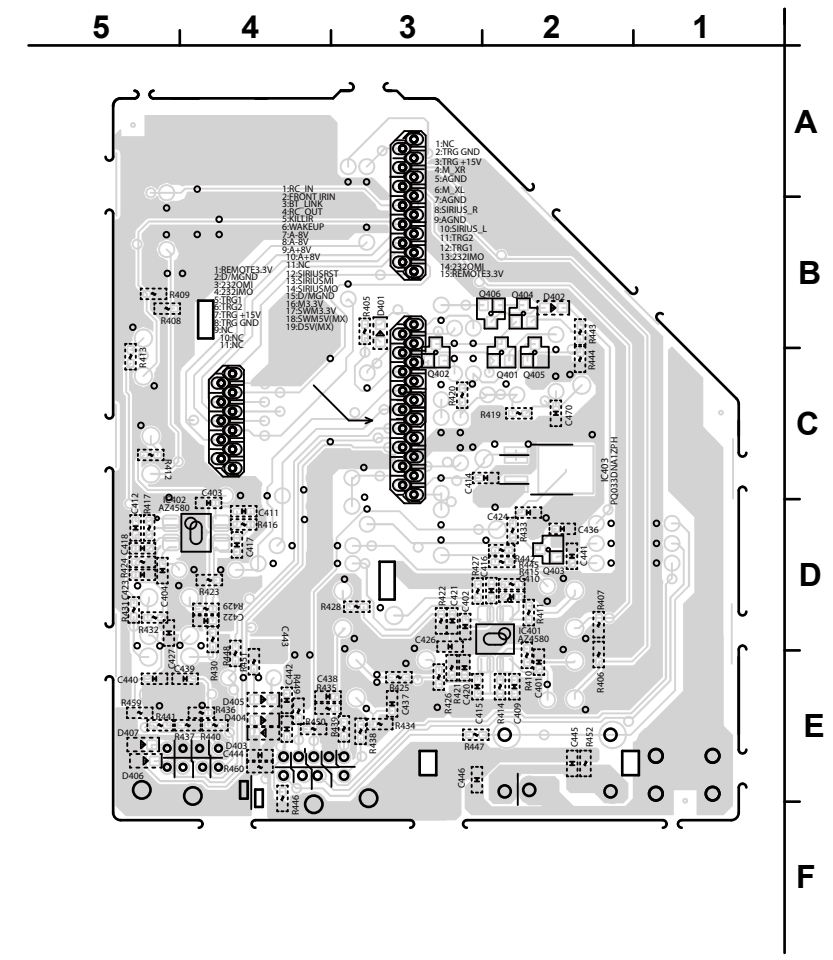

USB (FOIL SIDE)

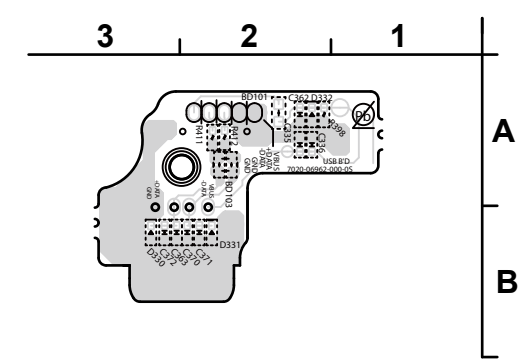

**鉛フリー半田**  
半田付けには、鉛フリー半田 (Sn-Ag-Cu) を使用してください。

**Lead-free Solder**  
When soldering, use the Lead-free Solder (Sn-Ag-Cu).

FRONT (COMPONENT SIDE)

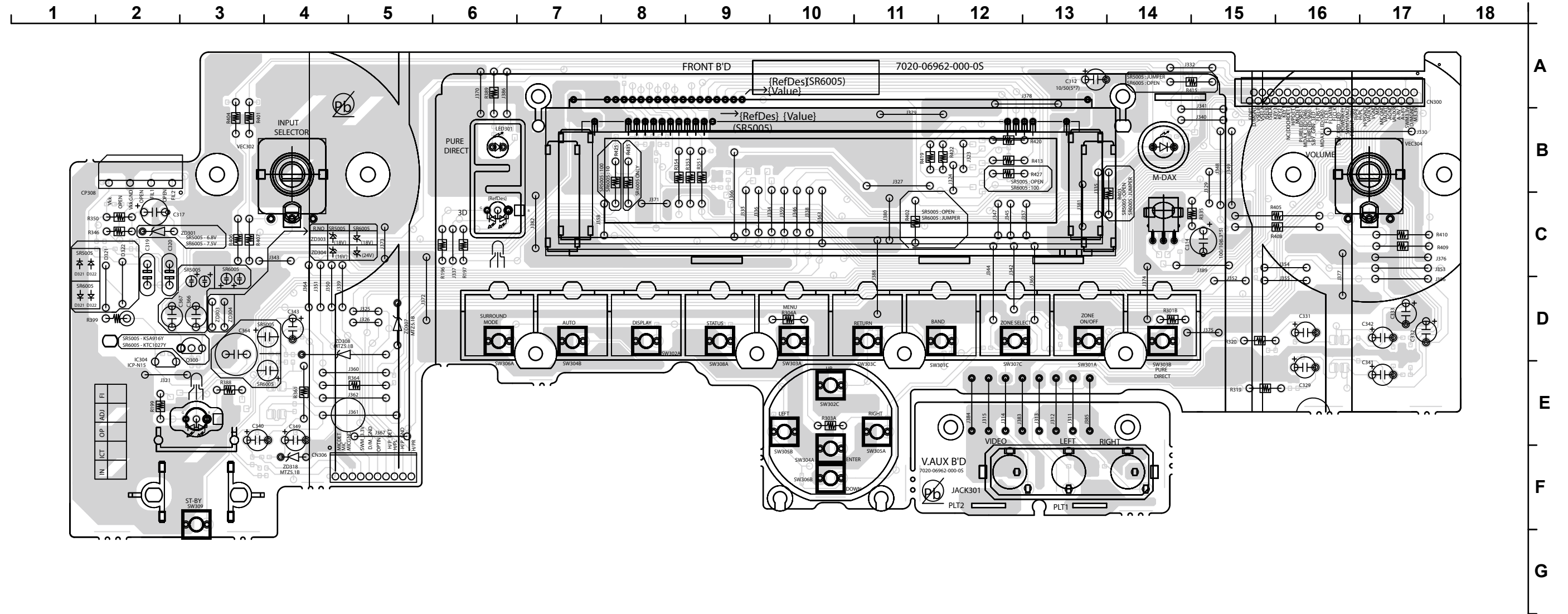

H/P (COMPONENT SIDE)

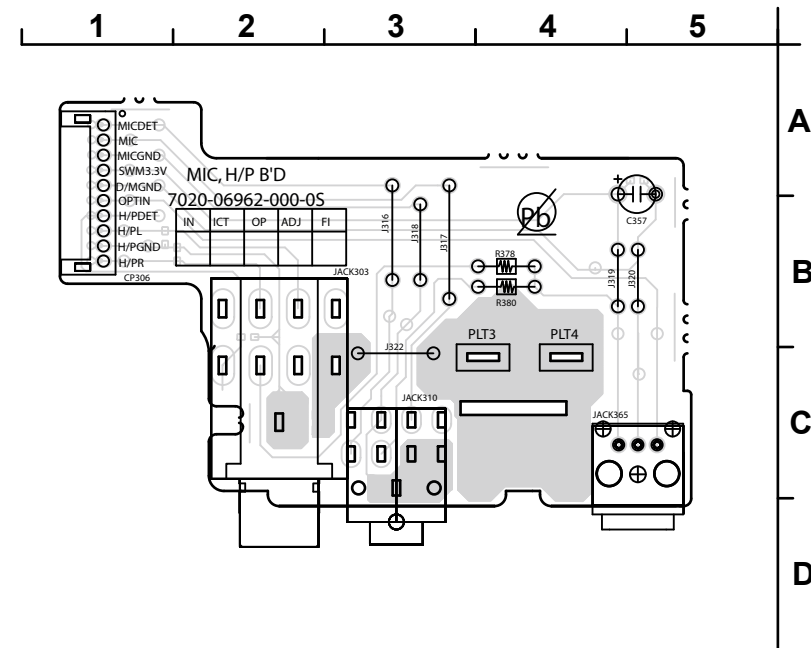

**鉛フリー半田**  
半田付けには、鉛フリー半田 (Sn-Ag-Cu) を使用してください。

**Lead-free Solder**  
When soldering, use the Lead-free Solder (Sn-Ag-Cu).

FRONT (FOIL SIDE)

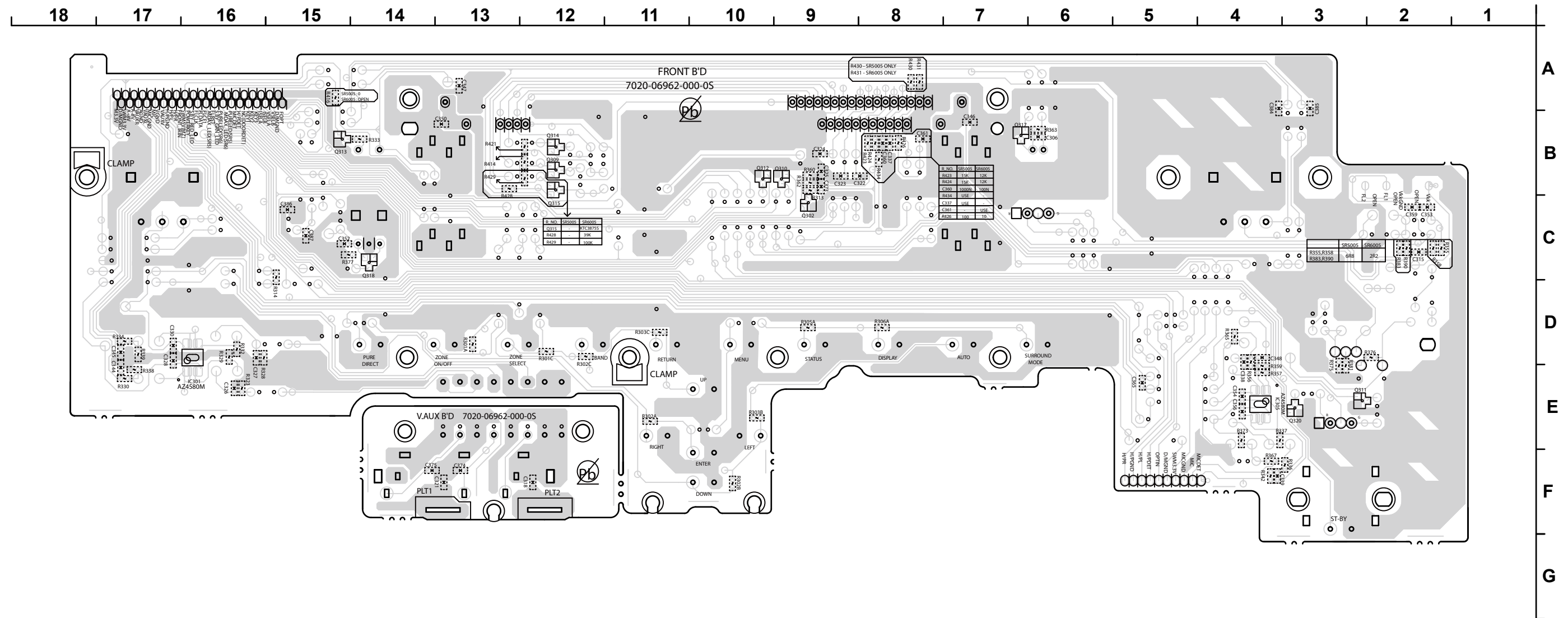

H/P (FOIL SIDE)

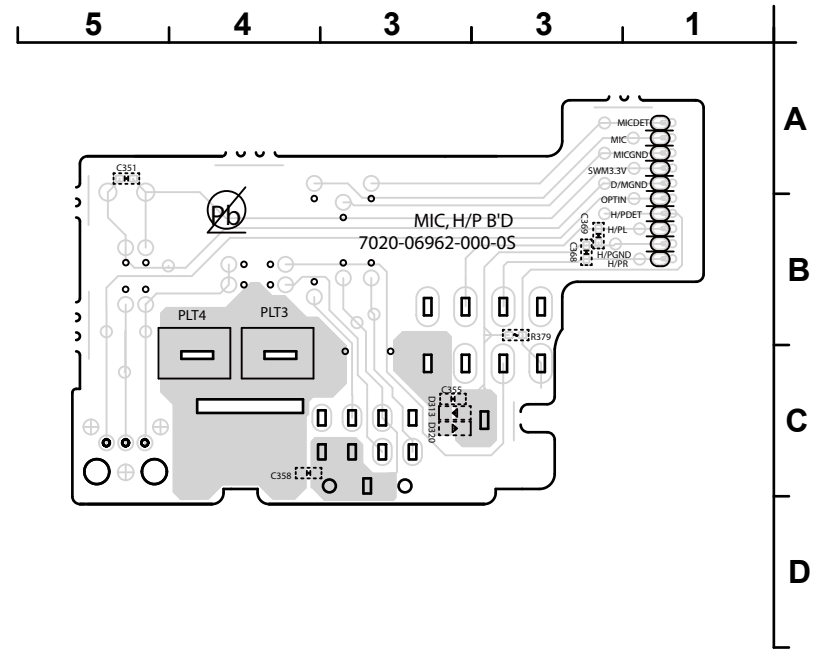

**鉛フリー半田**  
半田付けには、鉛フリー半田 (Sn-Ag-Cu) を使用してください。

**Lead-free Solder**  
When soldering, use the Lead-free Solder (Sn-Ag-Cu).

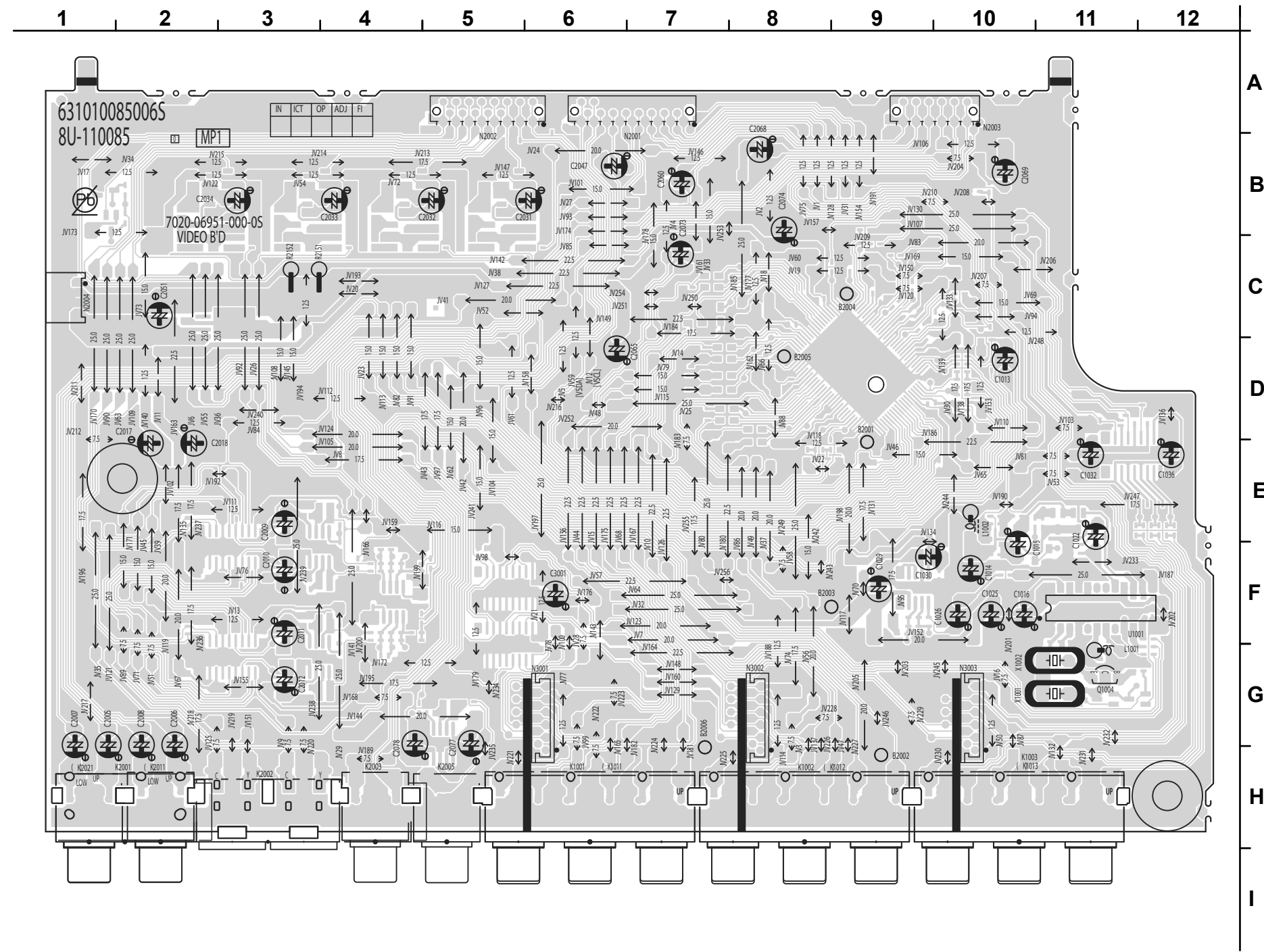

**鉛フリー半田**

半田付けには、鉛フリー半田 (Sn-Ag-Cu) を使用してください。

**Lead-free Solder**

When soldering, use the Lead-free Solder (Sn-Ag-Cu).

12 11 10 9 8 7 6 5 4 3 2 1

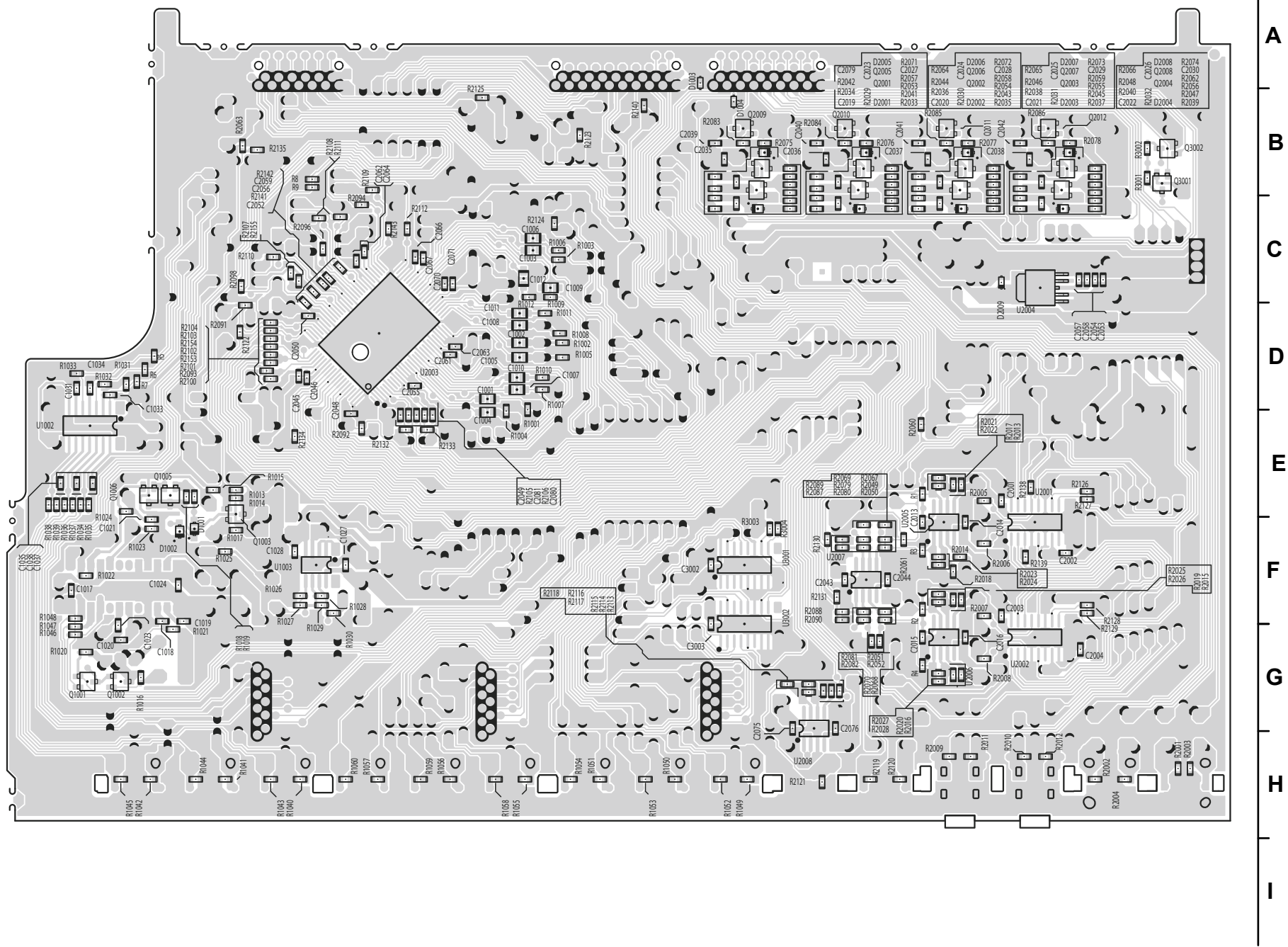

A  
B  
C  
D  
E  
F  
G  
H  
I

**鉛フリー半田**  
半田付けには、鉛フリー半田 (Sn-Ag-Cu) を使用してください。  
**Lead-free Solder**  
When soldering, use the Lead-free Solder (Sn-Ag-Cu).

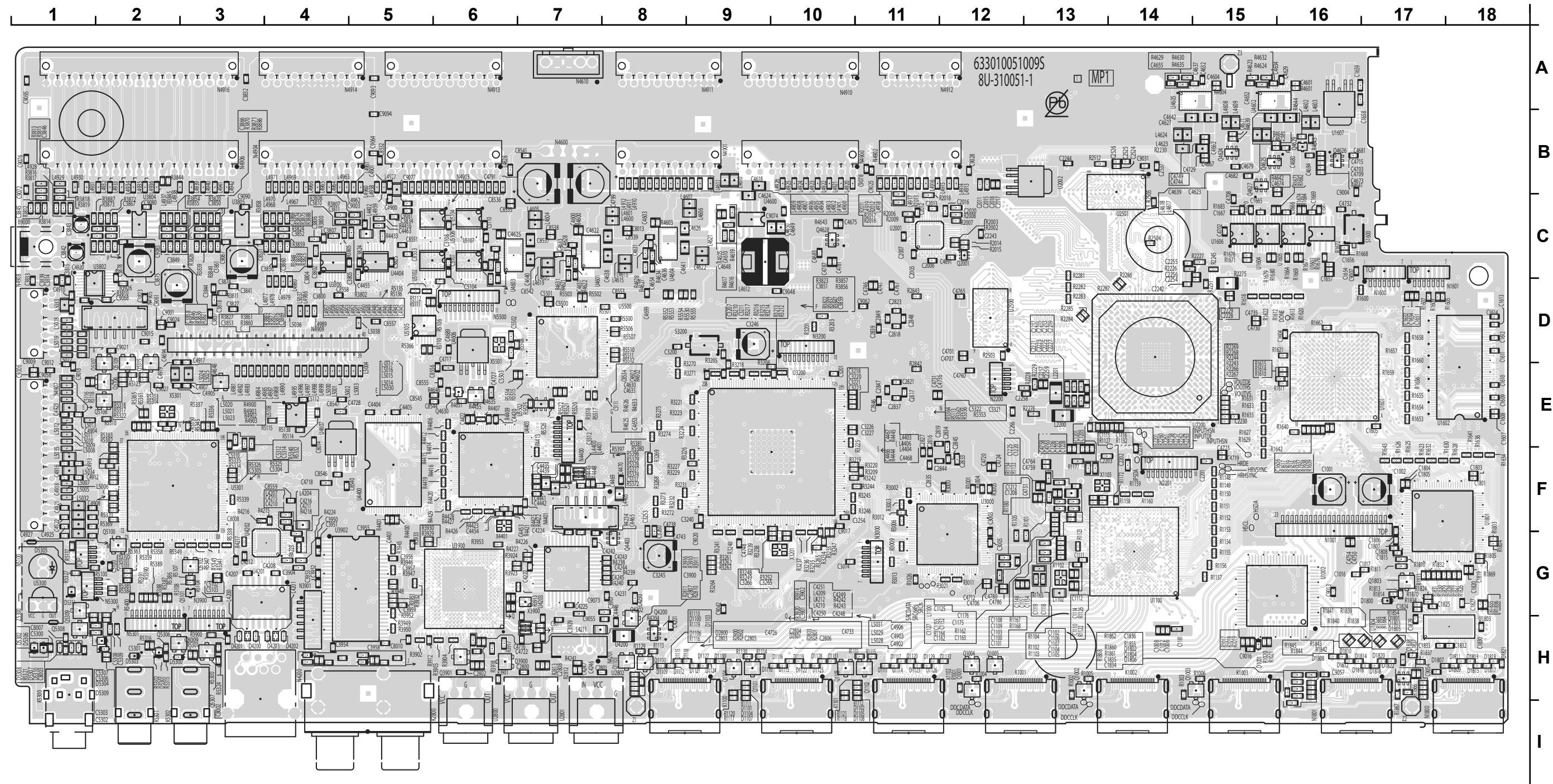

**鉛フリー半田**

半田付けには、鉛フリー半田 (Sn-Ag-Cu) を使用してください。

**Lead-free Solder**

When soldering, use the Lead-free Solder (Sn-Ag-Cu).

18 17 16 15 14 13 12 11 10 9 8 7 6 5 4 3 2 1

A  
B  
C  
D  
E  
F  
G  
H  
I

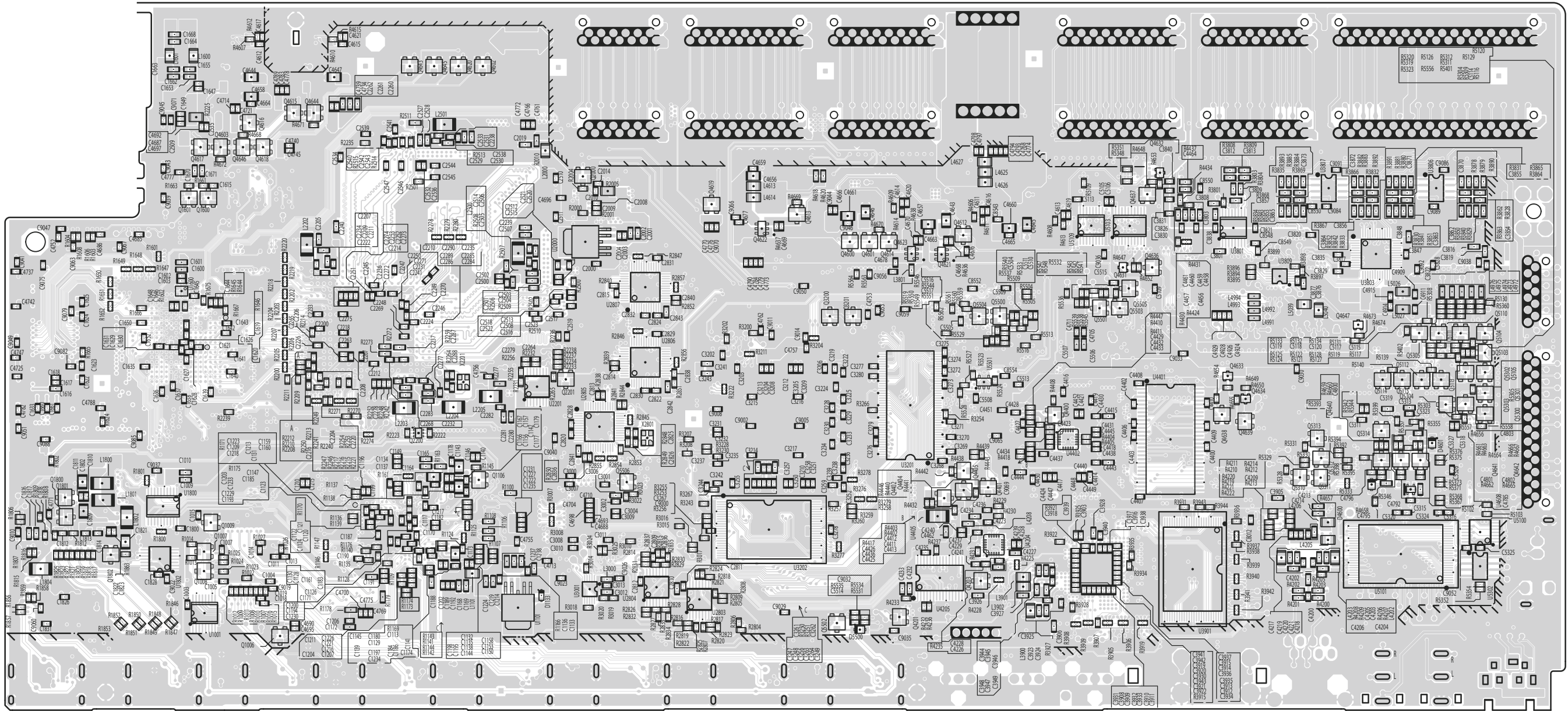

**鉛フリー半田**  
半田付けには、鉛フリー半田 (Sn-Ag-Cu) を使用してください。  
**Lead-free Solder**  
When soldering, use the Lead-free Solder (Sn-Ag-Cu).



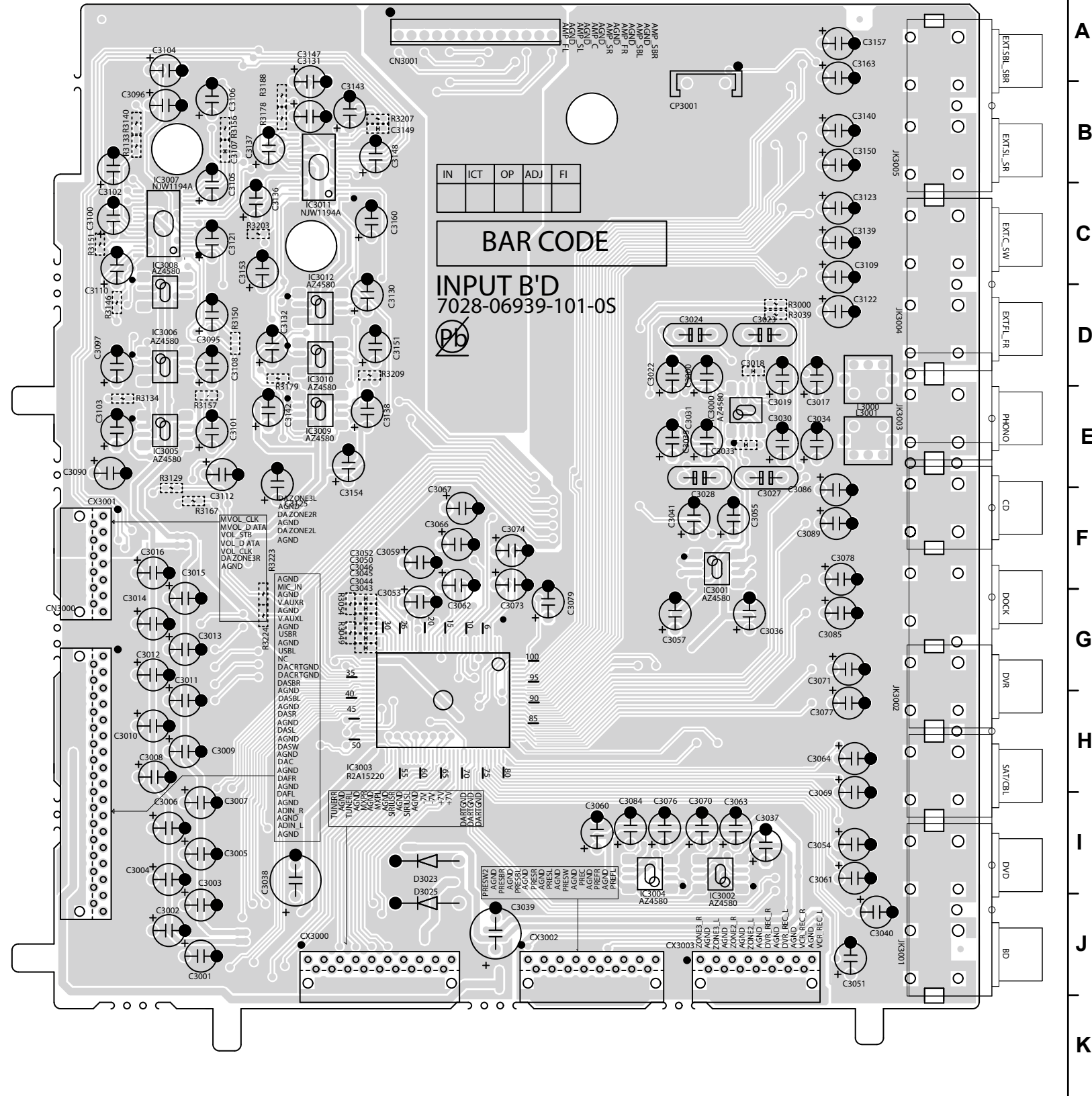

**鉛フリー半田**

半田付けには、鉛フリー半田 (Sn-Ag-Cu) を使用してください。

**Lead-free Solder**

When soldering, use the Lead-free Solder (Sn-Ag-Cu).

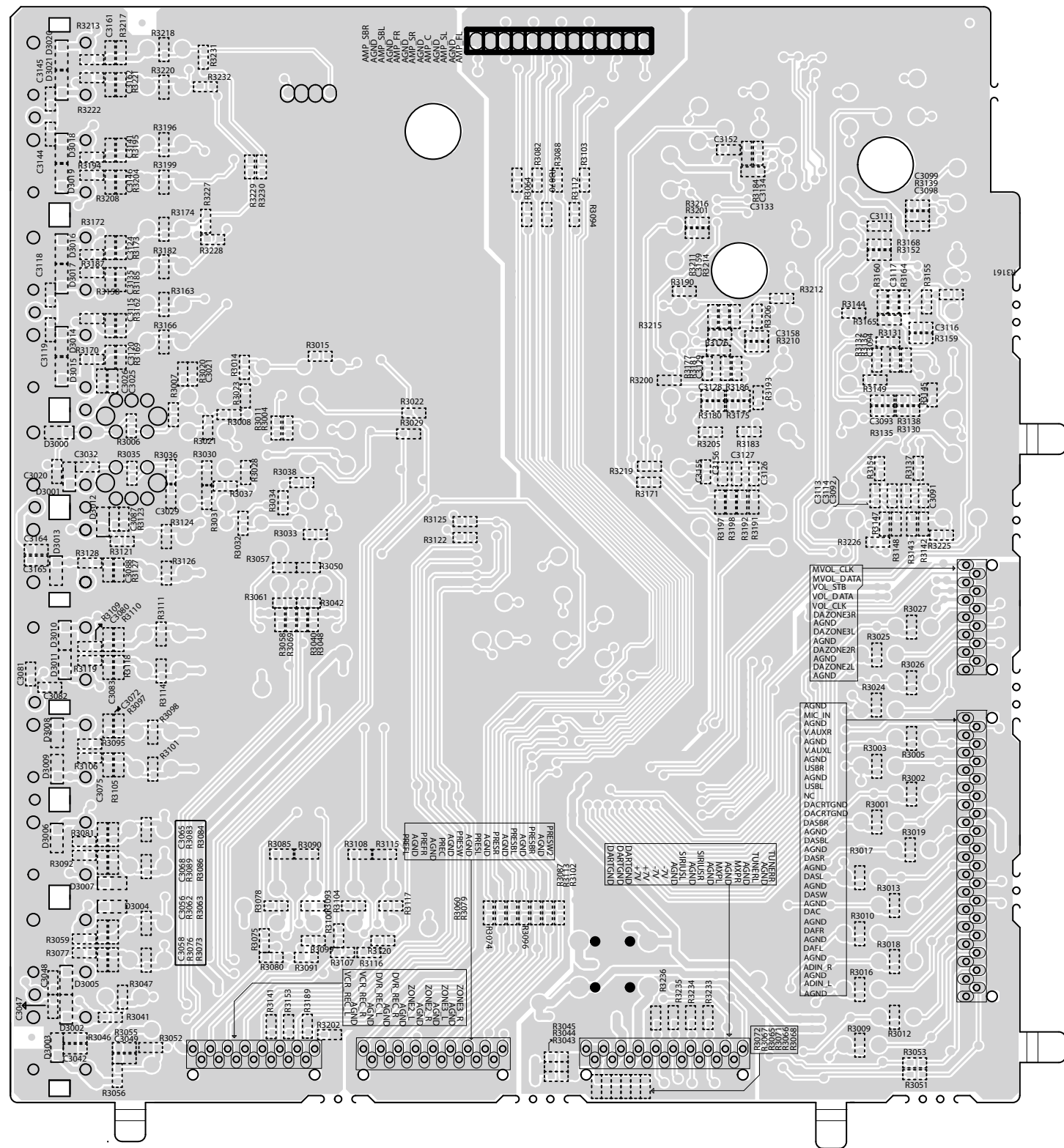

**鉛フリー半田**  
 半田付けには、鉛フリー半田 (Sn-Ag-Cu) を使用してください。

**Lead-free Solder**  
 When soldering, use the Lead-free Solder (Sn-Ag-Cu).

PREOUT (COMPONENT SIDE)

1 2 3 4 5 6 7 8 9 10 11

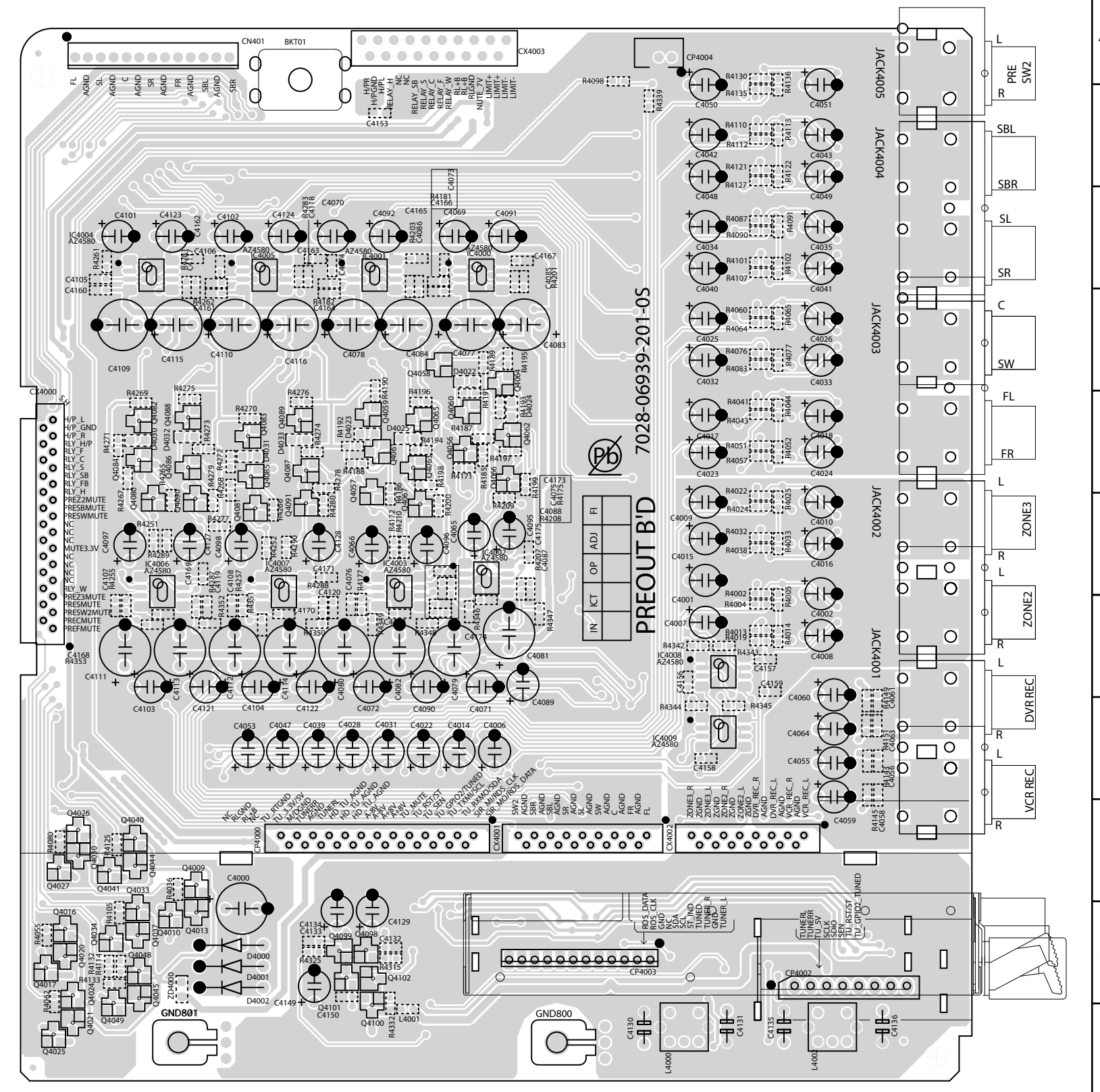

A  
B  
C  
D  
E  
F  
G  
H  
I  
J  
K

鉛フリー半田

半田付けには、鉛フリー半田 (Sn-Ag-Cu) を使用してください。

Lead-free Solder

When soldering, use the Lead-free Solder (Sn-Ag-Cu).

11 10 9 8 7 6 5 4 3 2 1

A  
B  
C  
D  
E  
F  
G  
H  
I  
J  
K

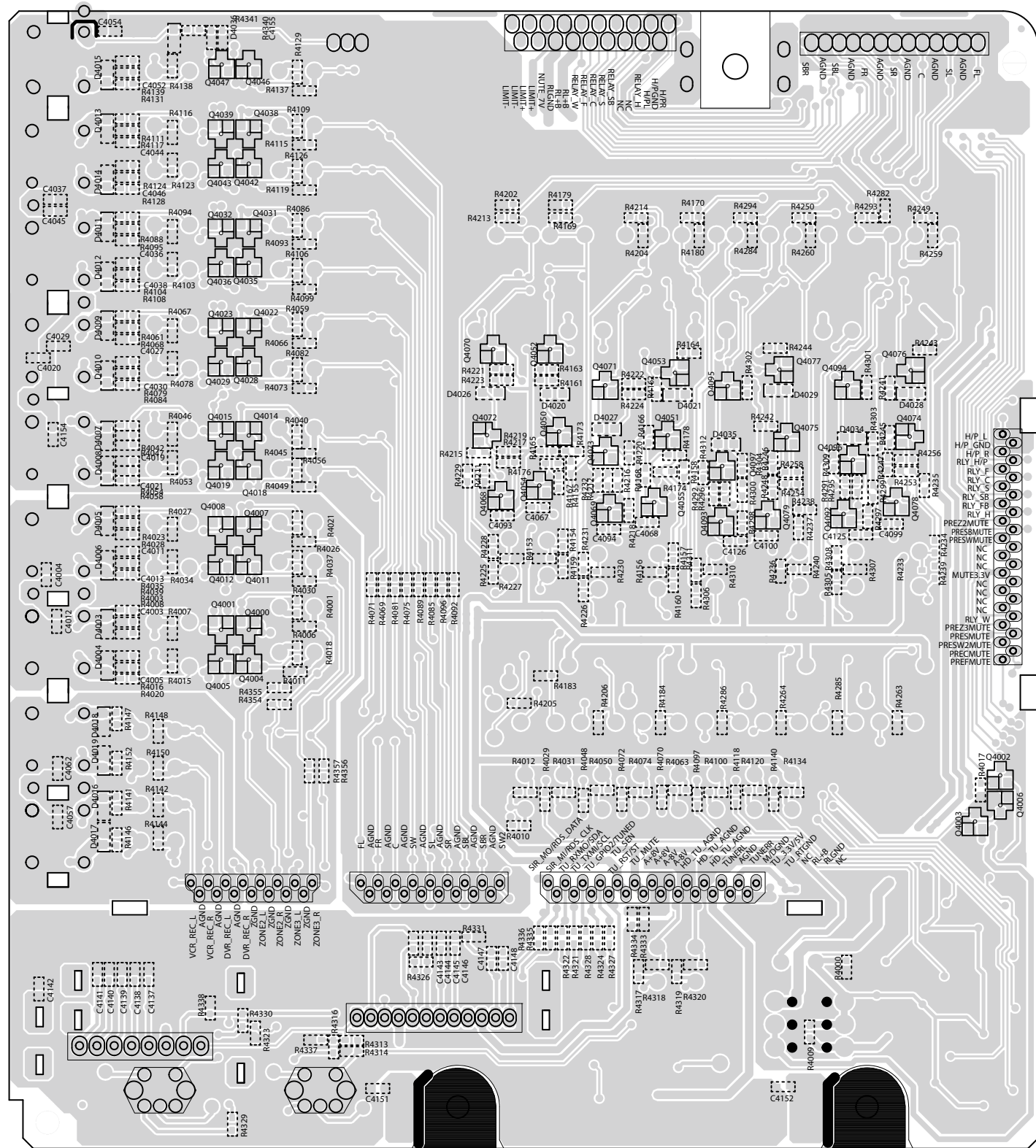

**鉛フリー半田**  
半田付けには、鉛フリー半田 (Sn-Ag-Cu) を使用してください。

**Lead-free Solder**  
When soldering, use the Lead-free Solder (Sn-Ag-Cu).

# 7CH-AMP B'D (1/2)

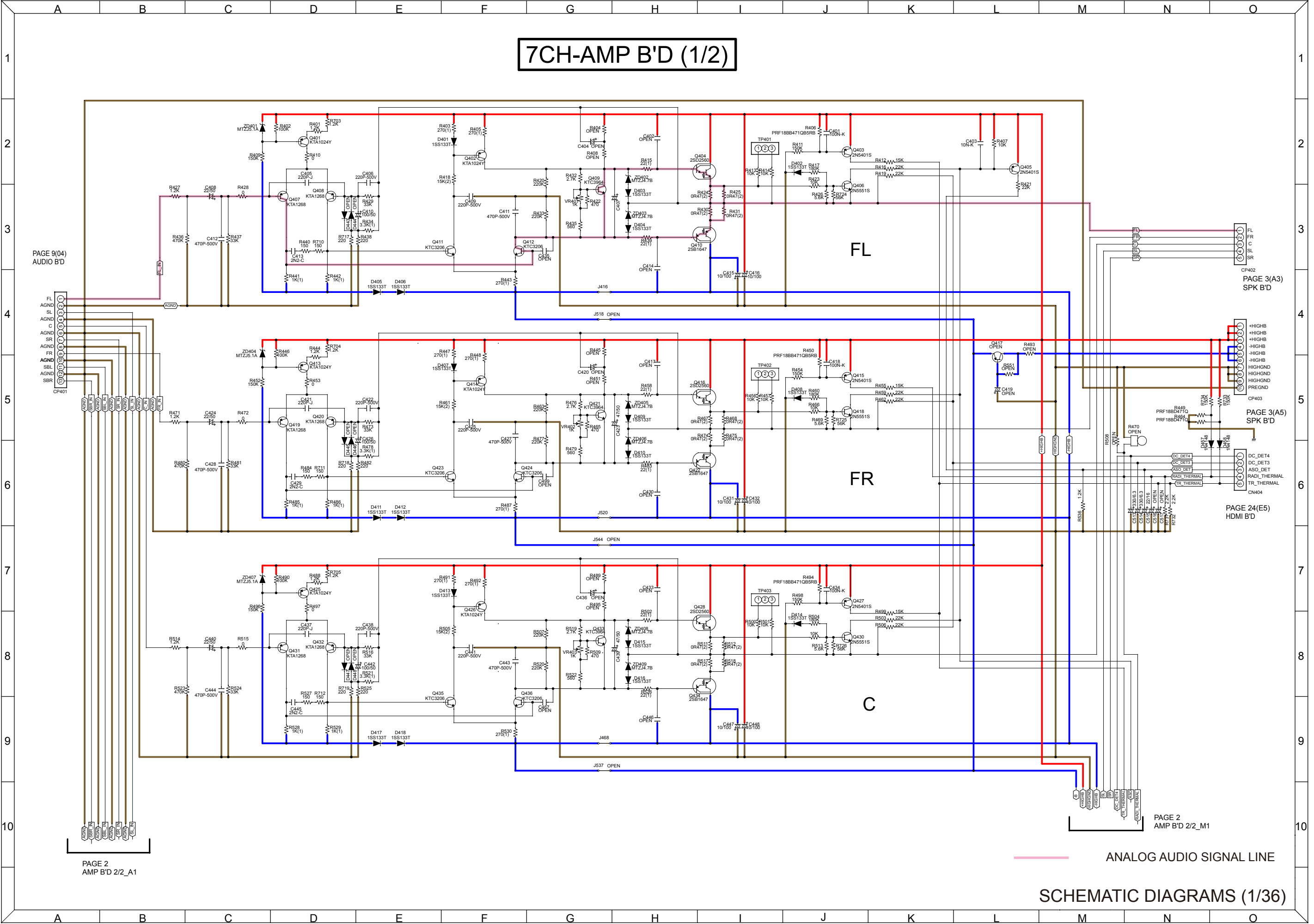

ANALOG AUDIO SIGNAL LINE

SCHEMATIC DIAGRAMS (1/36)

7CH-AMP B'D (2/2)

PAGE 3(A4)  
SPK B'D

SCHEMATIC DIAGRAMS (2/36)

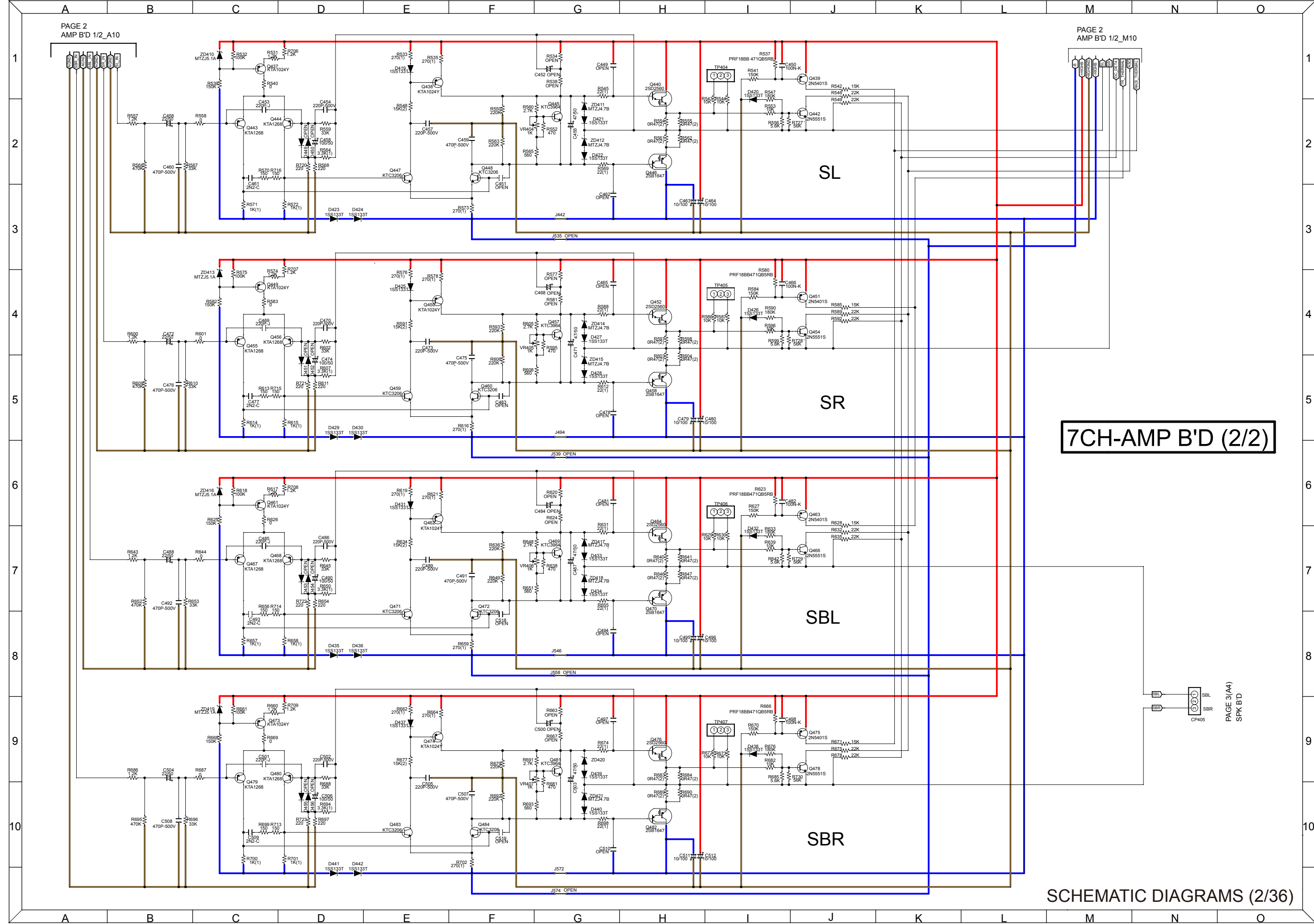

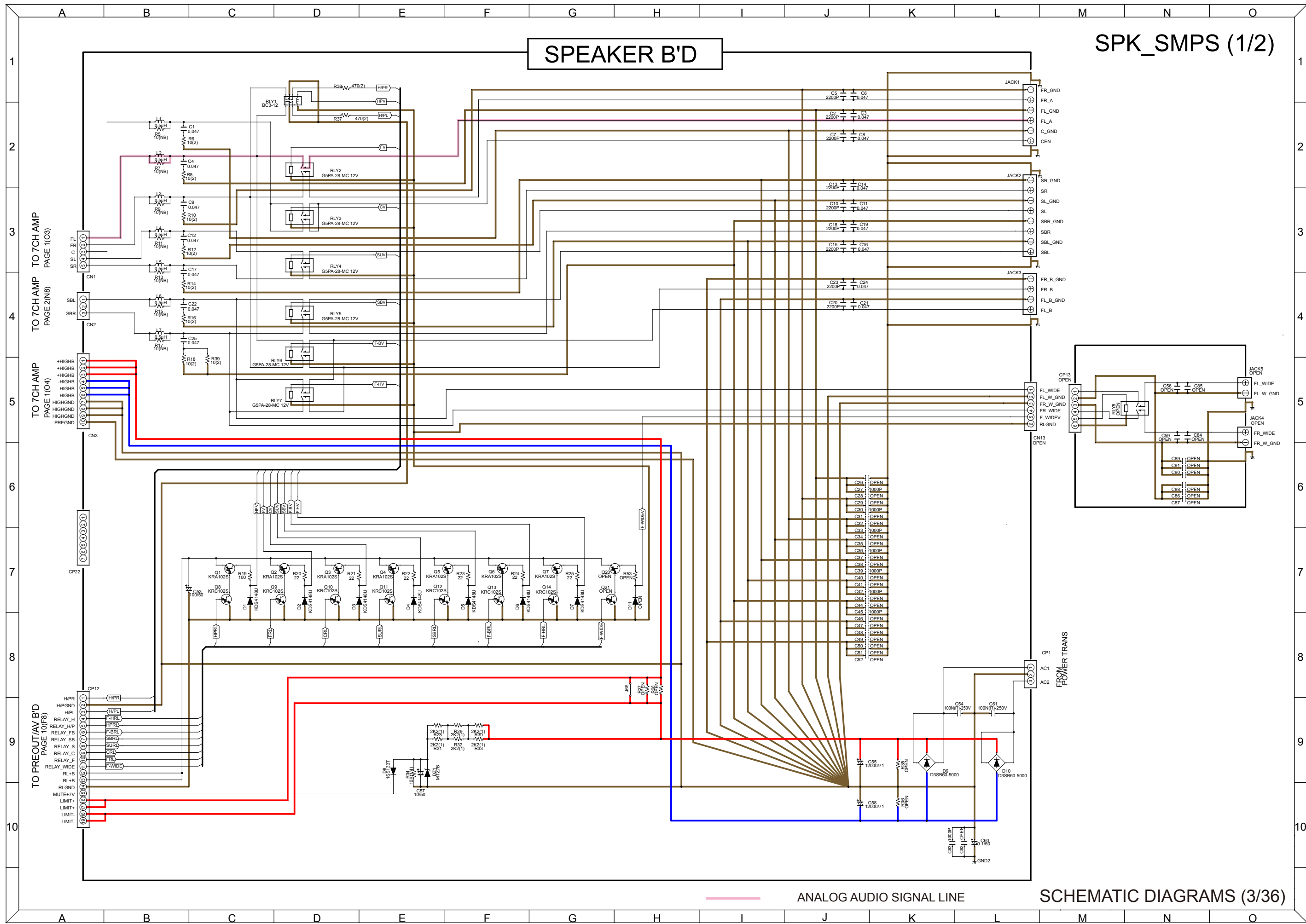

SPEAKER B'D

SPK\_SMPS (1/2)

TO 7CH AMP PAGE 1(O3)  
 TO 7CH AMP PAGE 2(N8)  
 TO 7CH AMP PAGE 1(O4)  
 TO PREOUT/AV B'D PAGE 10(F8)

- C28: OPEN
- C27: 1000P
- C28: OPEN
- C29: OPEN
- C30: 1000P
- C31: OPEN
- C32: OPEN
- C33: 1000P
- C34: OPEN
- C35: OPEN
- C36: 1000P
- C37: OPEN
- C38: OPEN
- C39: 1000P
- C40: OPEN
- C41: OPEN
- C42: 1000P
- C43: OPEN
- C44: OPEN
- C45: 1000P
- C46: OPEN
- C47: OPEN
- C48: OPEN
- C49: OPEN
- C50: OPEN
- C51: OPEN
- C52: OPEN

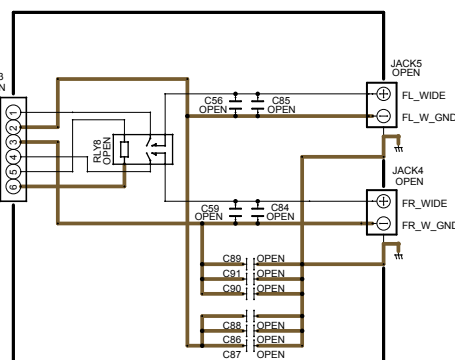

ANALOG AUDIO SIGNAL LINE

SCHEMATIC DIAGRAMS (3/36)

# SMPS B'D

SPK\_SMPS 2/2

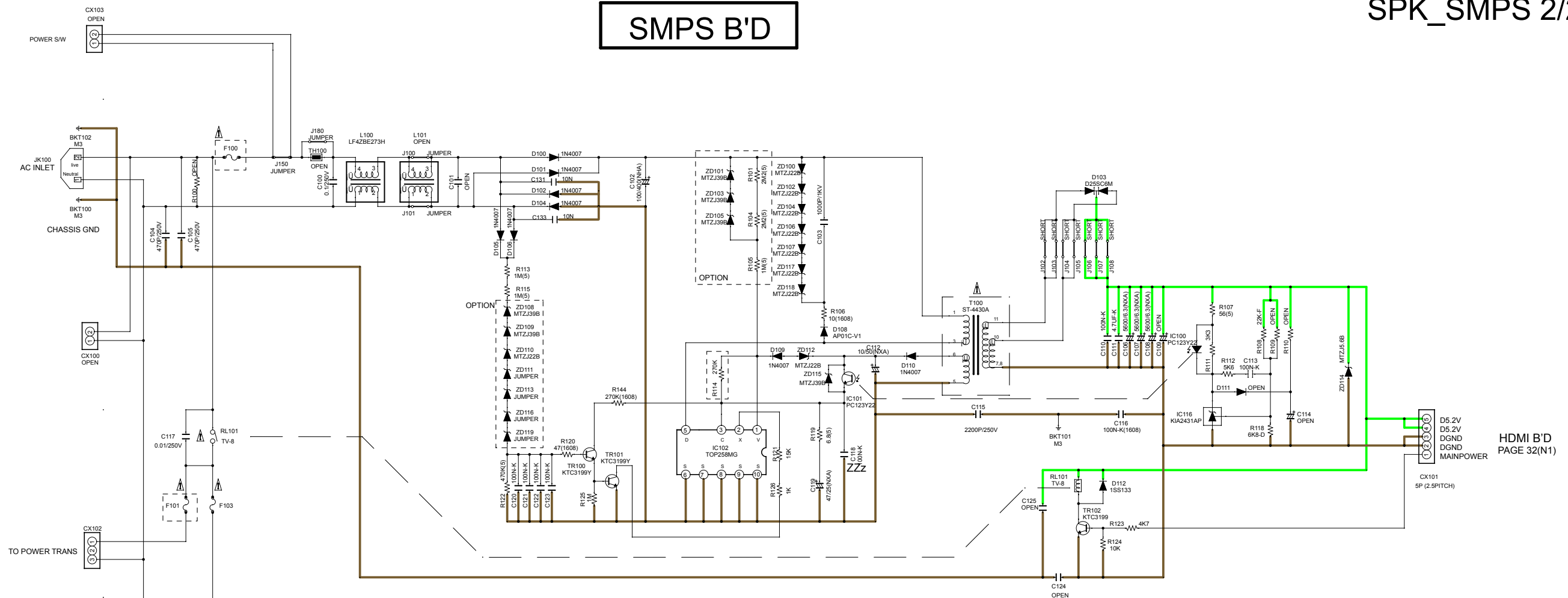

OPTION TABLE

	ZD108	ZD109	ZD110	ZD111	ZD113	ZD116	ZD119	ZD101	ZD103	ZD105	R101	R104	R105	R114
U	MTZJ39B	MTZJ39B	MTZJ22B	JUMPER	JUMPER	JUMPER	JUMPER	MTZJ39B	MTZJ39B	MTZJ39B	2M(5)	2M(5)	1M(5)	270K
N	1M(5)	1M(5)	MTZJ39B	MTZJ39B	MTZJ39B	MTZJ39B	MTZJ39B	OPEN	OPEN	OPEN	OPEN	OPEN	OPEN	56K
F	MTZJ39B	MTZJ39B	JUMPER	JUMPER	JUMPER	JUMPER	JUMPER	MTZJ39B	MTZJ39B	MTZJ39B	2M(5)	2M(5)	1M(5)	270K
K	1M(5)	1M(5)	MTZJ39B	MTZJ39B	MTZJ39B	MTZJ39B	MTZJ39B	OPEN	OPEN	OPEN	OPEN	OPEN	OPEN	56K

	F100			F101		
	SR5005	SR6005	SR7005	SR5005	SR6005	SR7005
U	2A/250V	2A/250V	2A/250V	6.3A/250V	6.3A/250V	8A/250V
N	1.6A/250V	1.6A/250V	1.6A/250V	3.15A/250V	3.15A/250V	3.15A/250V
F	2A/250V	-	2A/250V	6.3A/250V	-	8A/250V
K	1.6A/250V	1.6A/250V	1.6A/250V	3.15A/250V	3.15A/250V	3.15A/250V

HDMI B'D  
PAGE 32(N1)



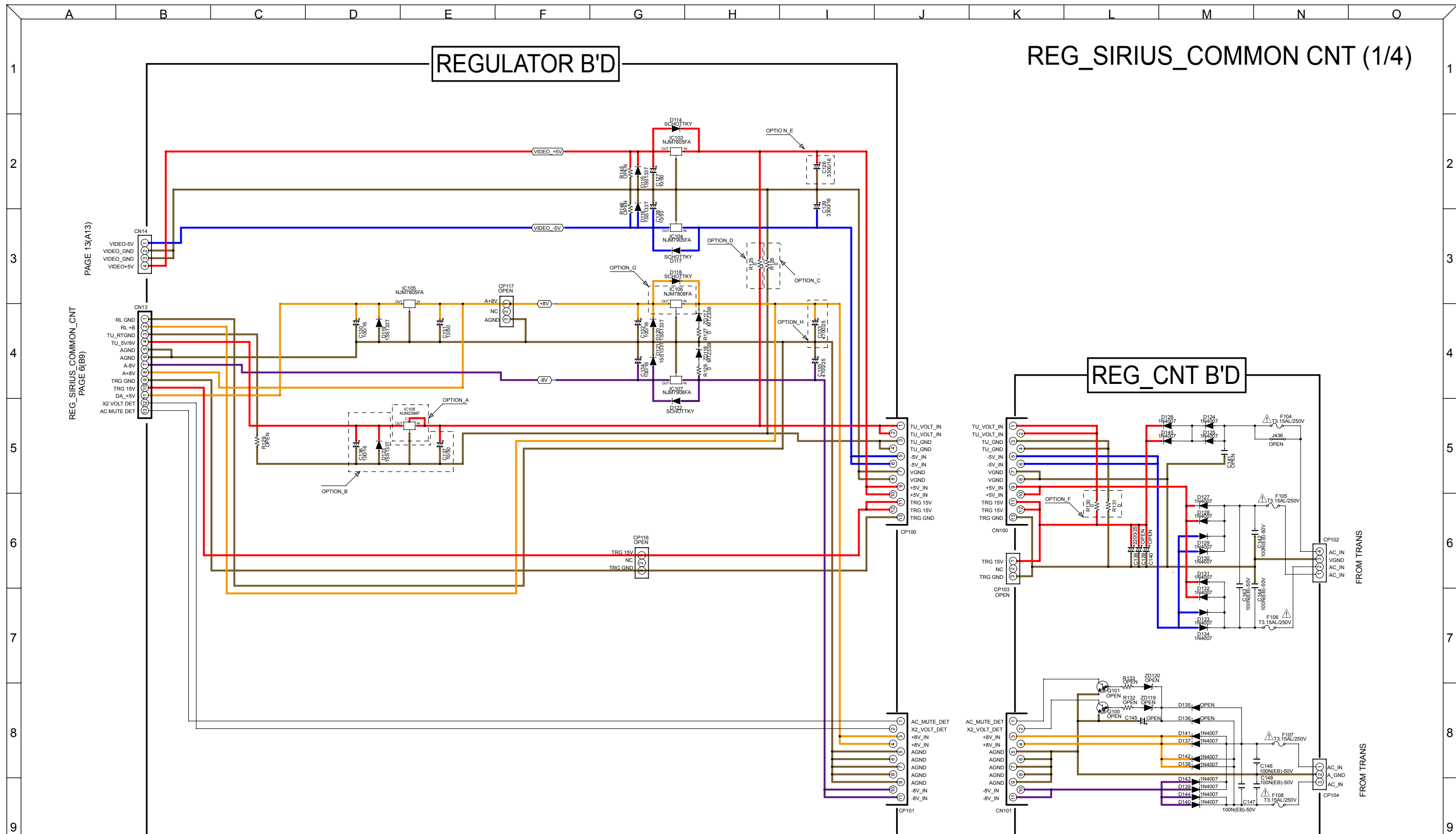

\*OPTION TABLE

MODEL	SR5005				SR6005			SR7005			
	U	N	F	K	U	N	K	U	N	F	K
OPTION_A	NJM2388F05	NJM2388F09	NJM2388F09	NJM2388F09	OPEN	NJM2388F09	NJM2388F09	OPEN	NJM2388F09	NJM2388F09	NJM2388F09
OPTION_B	USE	USE	USE	USE	NOT USE	USE	USE	NOT USE	USE	USE	USE
OPTION_C	NOT USE	USE	USE	USE	NOT USE	USE	USE	NOT USE	USE	USE	USE
OPTION_D	USE	NOT USE	NOT USE	NOT USE	NOT USE	NOT USE	NOT USE	NOT USE	NOT USE	NOT USE	NOT USE
OPTION_E	4700/16	3300/16	3300/16	3300/16	3300/16	3300/16	3300/16	3300/16	3300/16	3300/16	3300/16
OPTION_F	NOT USE	USE	USE	USE	NOT USE	USE	USE	NOT USE	USE	USE	USE
OPTION_G	NJM7808FA	NJM7808FA	NJM7808FA	NJM7808FA	NJM7808FA	NJM7808FA	NJM7808FA	BA08T	BA08T	BA08T	BA08T
OPTION_H	4700/25	4700/25	4700/25	4700/25	4700/25	4700/25	4700/25	6800/25	6800/25	6800/25	6800/25

# REG\_SIRIUS\_COMMON CNT 2/4

## SIDE CONNECTOR

OPTION A&B				
MODEL	U	N	F	K
SR5005	X	X	X	X
SR6005	O	X	X	X
SR7005	O	X	X	X

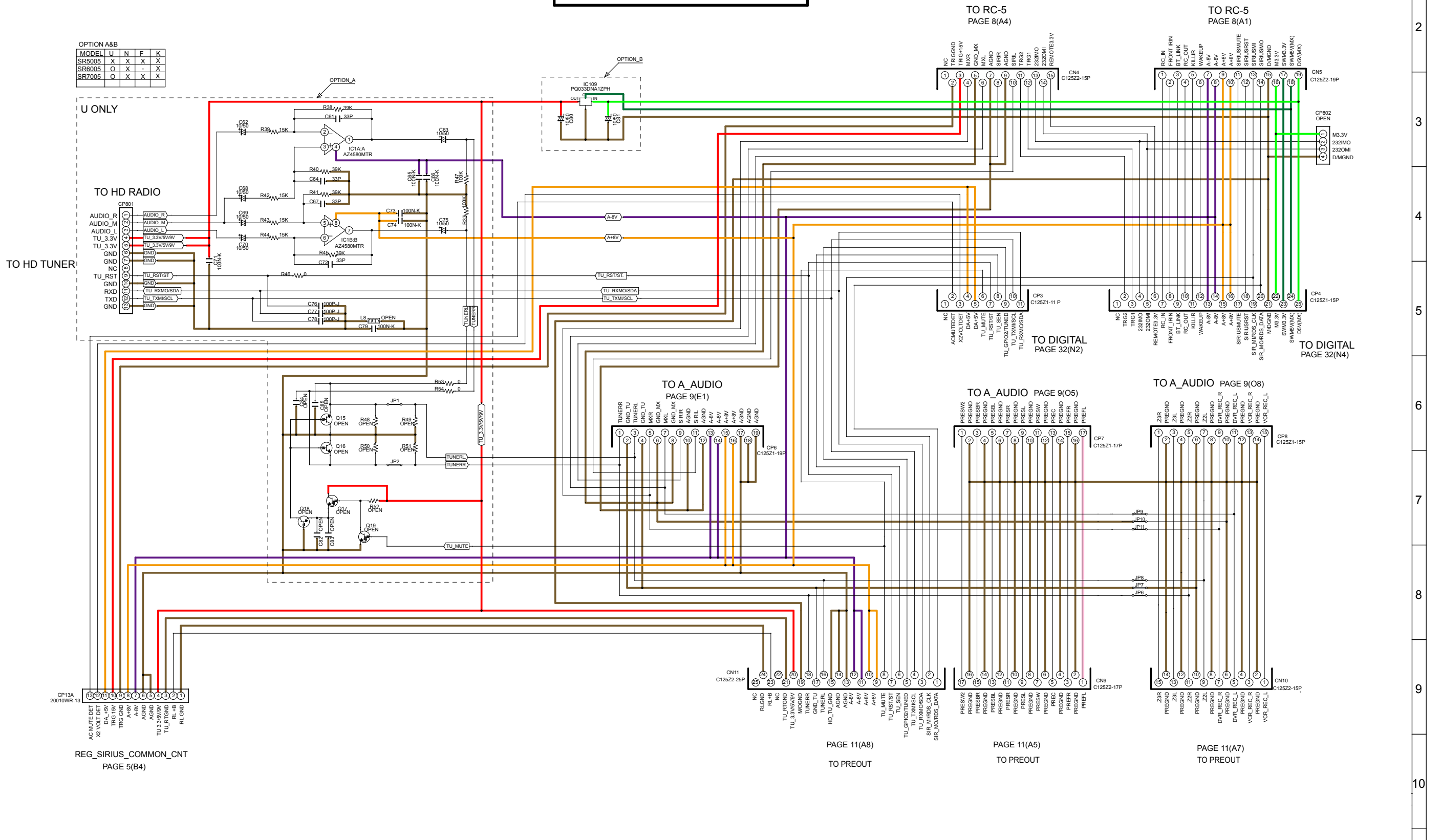

ANALOG AUDIO SIGNAL LINE

SCHEMATIC DIAGRAMS (6/36)

# FRONT CONNECTOR

# REG\_SIRIUS\_COMMON CNT 3/4

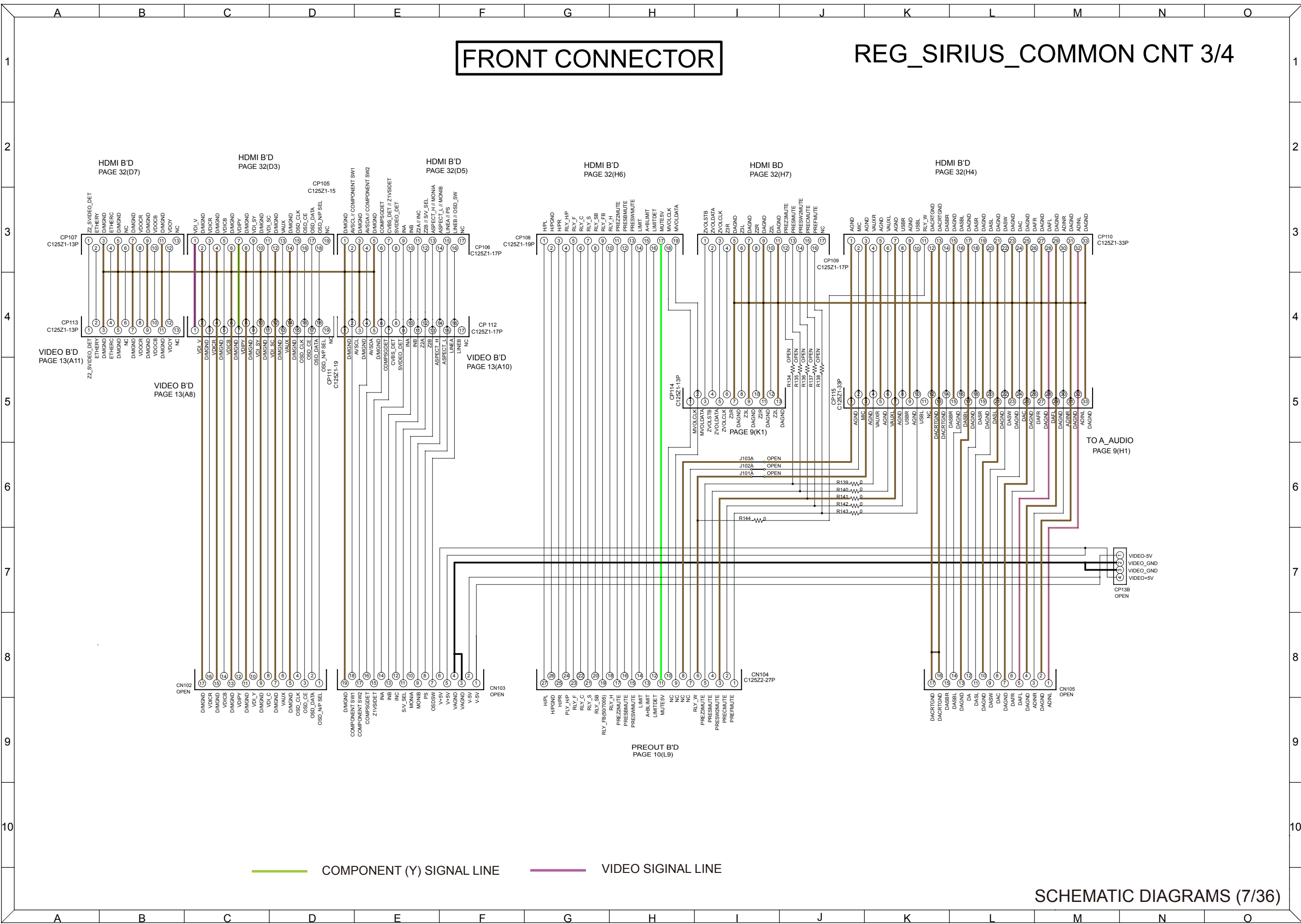

# REG\_SIRIUS\_COMMON CNT 4/4

## SIRIUS/RS232C/TRIGGER

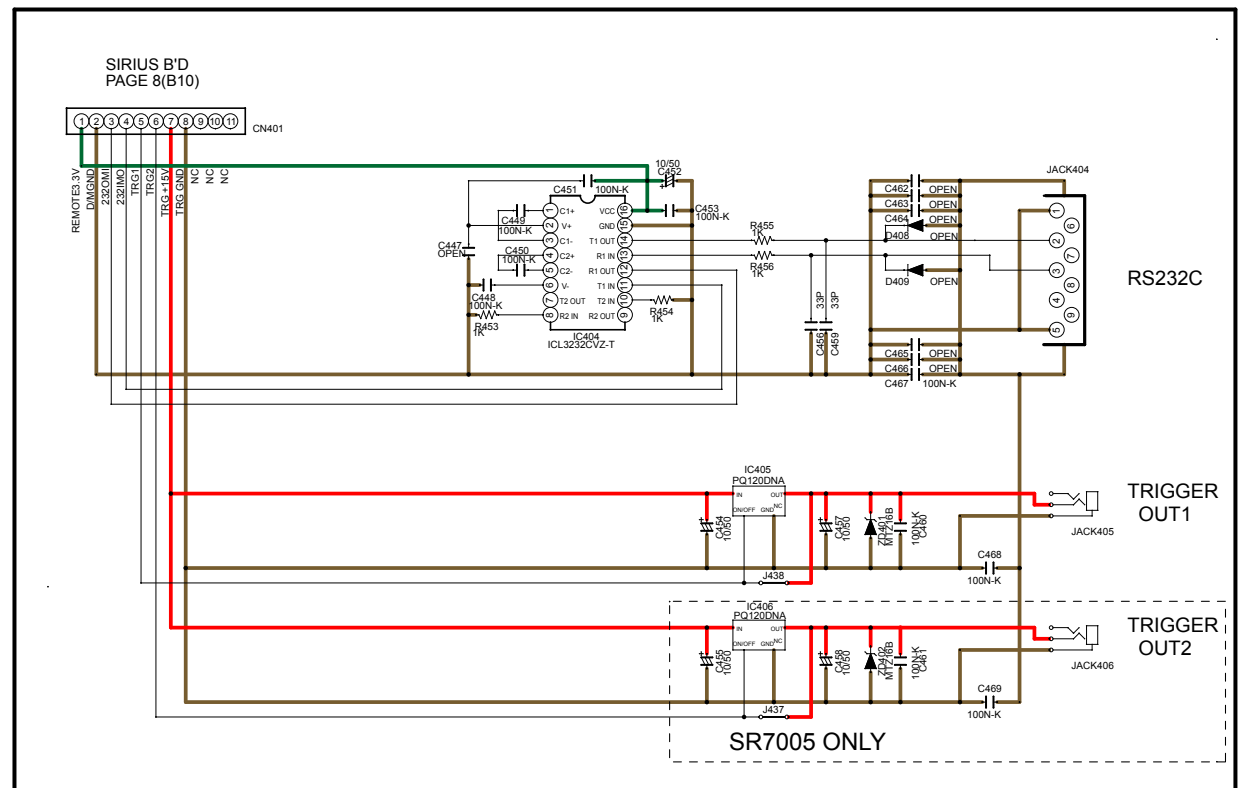
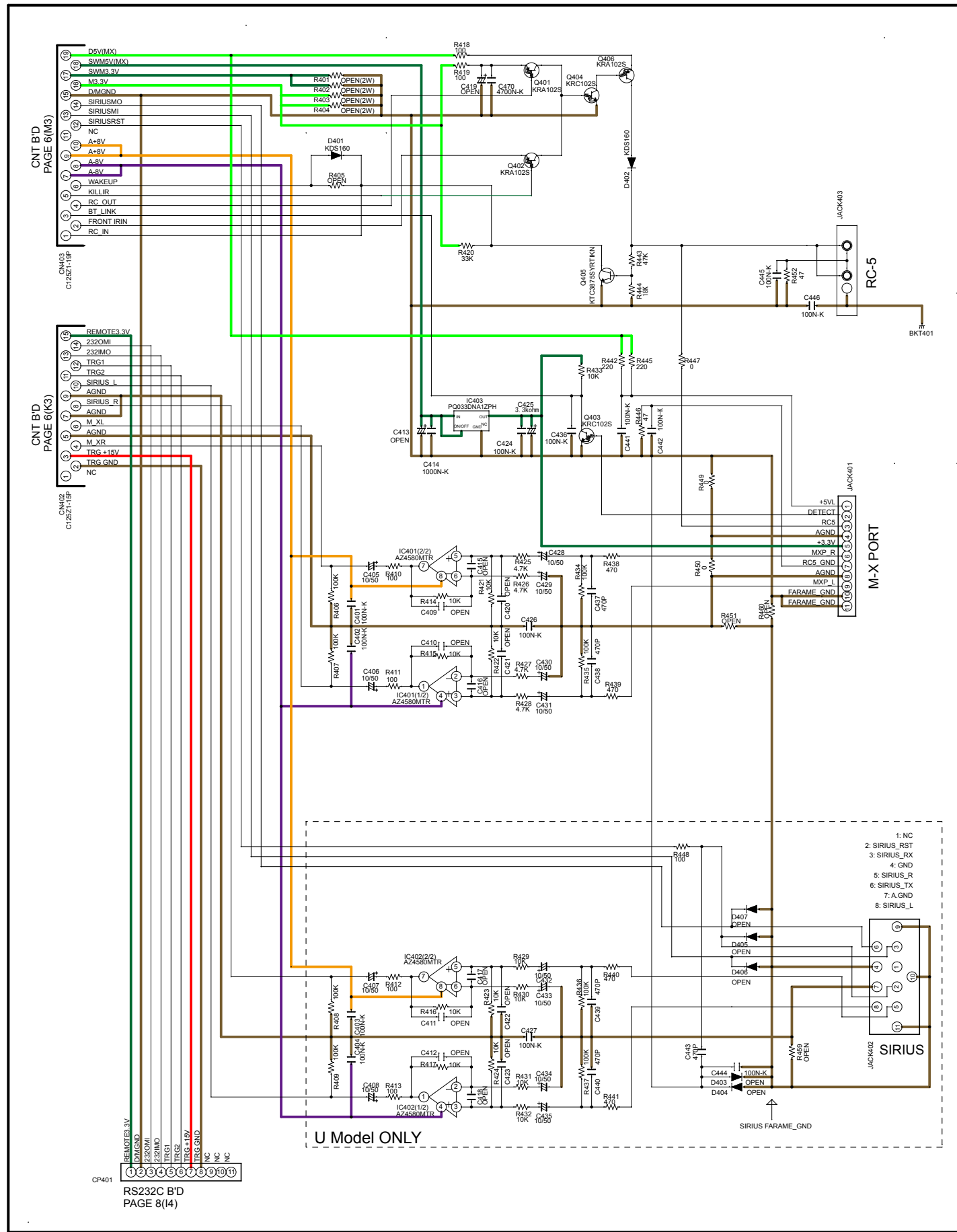

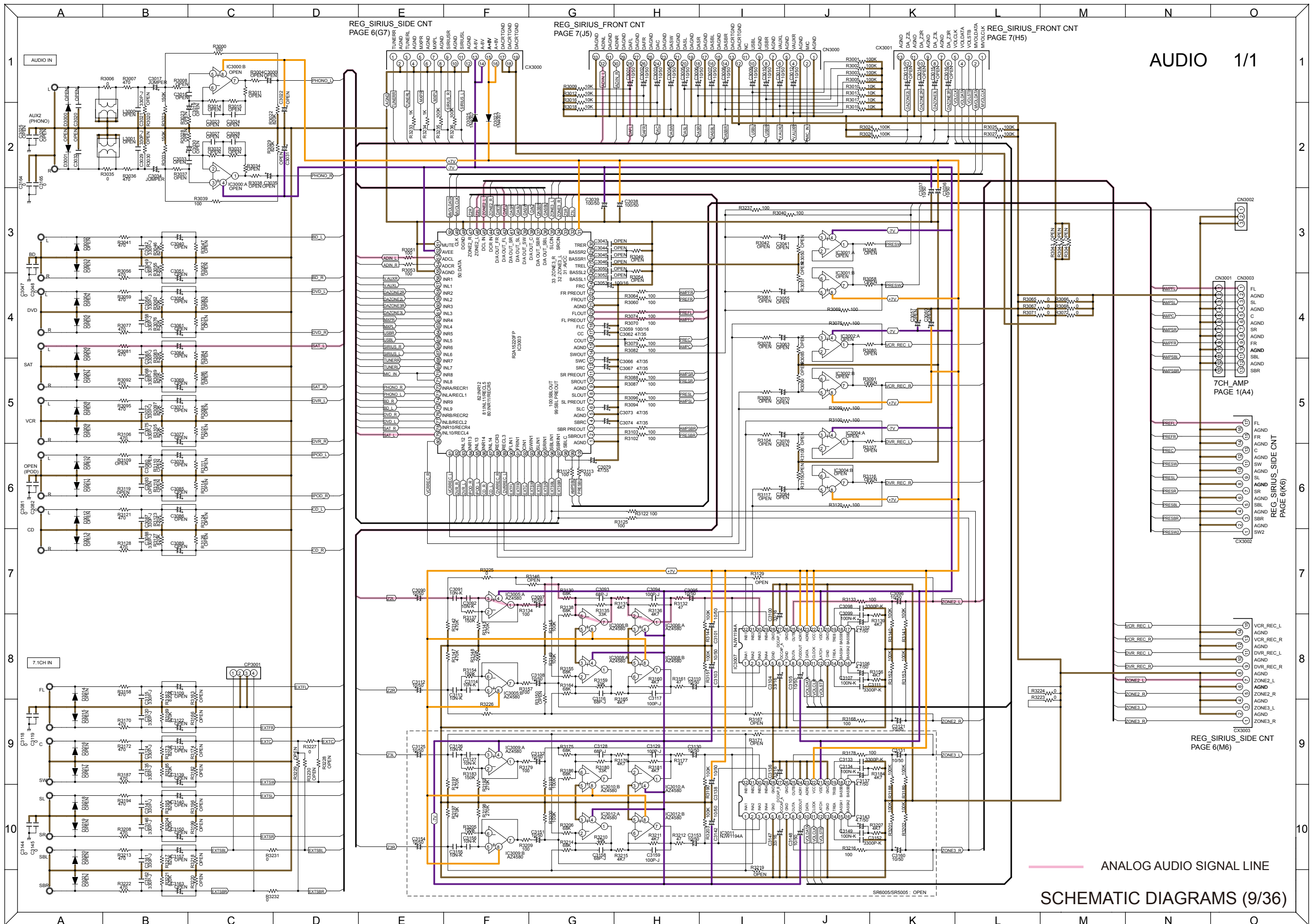

AUDIO 1/1

ANALOG AUDIO SIGNAL LINE  
SCHEMATIC DIAGRAMS (9/36)

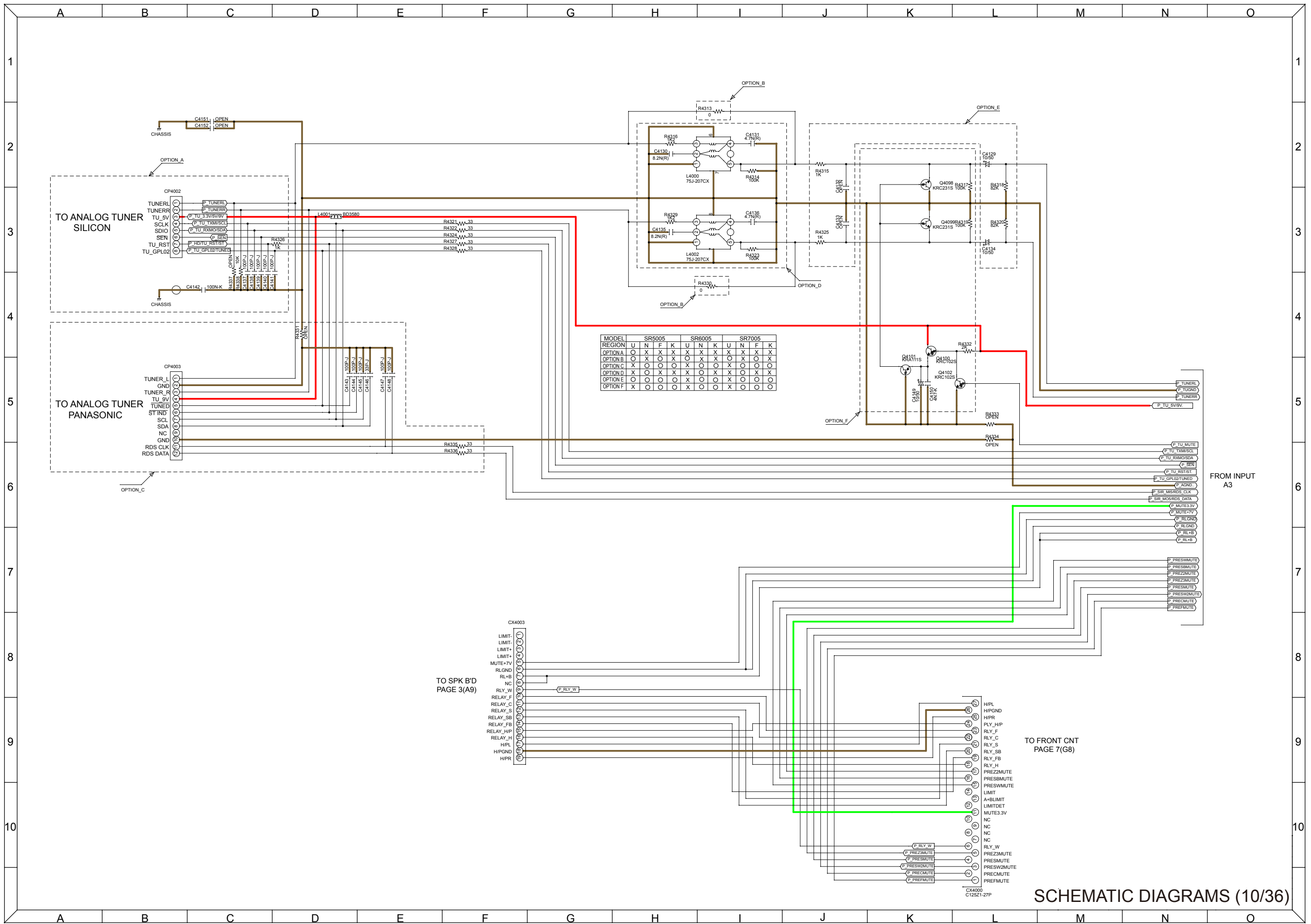

MODEL	SR5005				SR6005				SR7005			
REGION	U	N	F	K	U	N	K	U	N	F	K	
OPTION A	X	X	X	X	X	X	X	X	X	X	X	X
OPTION B	X	O	X	O	X	X	O	X	X	O	X	O
OPTION C	X	O	O	X	O	O	X	O	O	O	X	O
OPTION D	X	O	X	X	O	X	X	O	X	X	X	X
OPTION E	X	O	O	X	O	O	X	O	X	O	X	O
OPTION F	X	O	O	O	X	O	O	X	O	O	O	O

FROM INPUT A3

TO FRONT CNT PAGE 7(G8)

TO SPK B'D PAGE 3(A9)

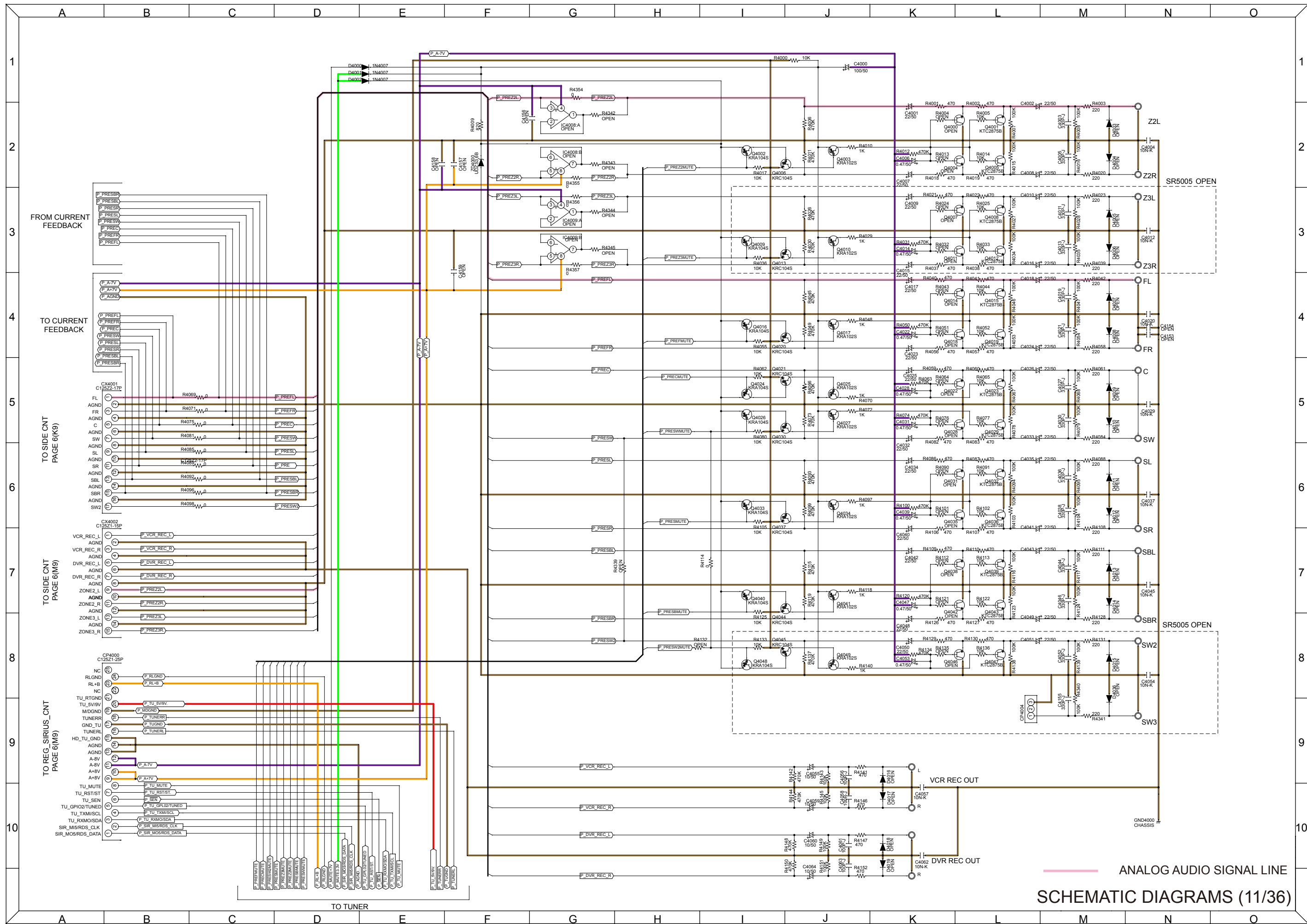

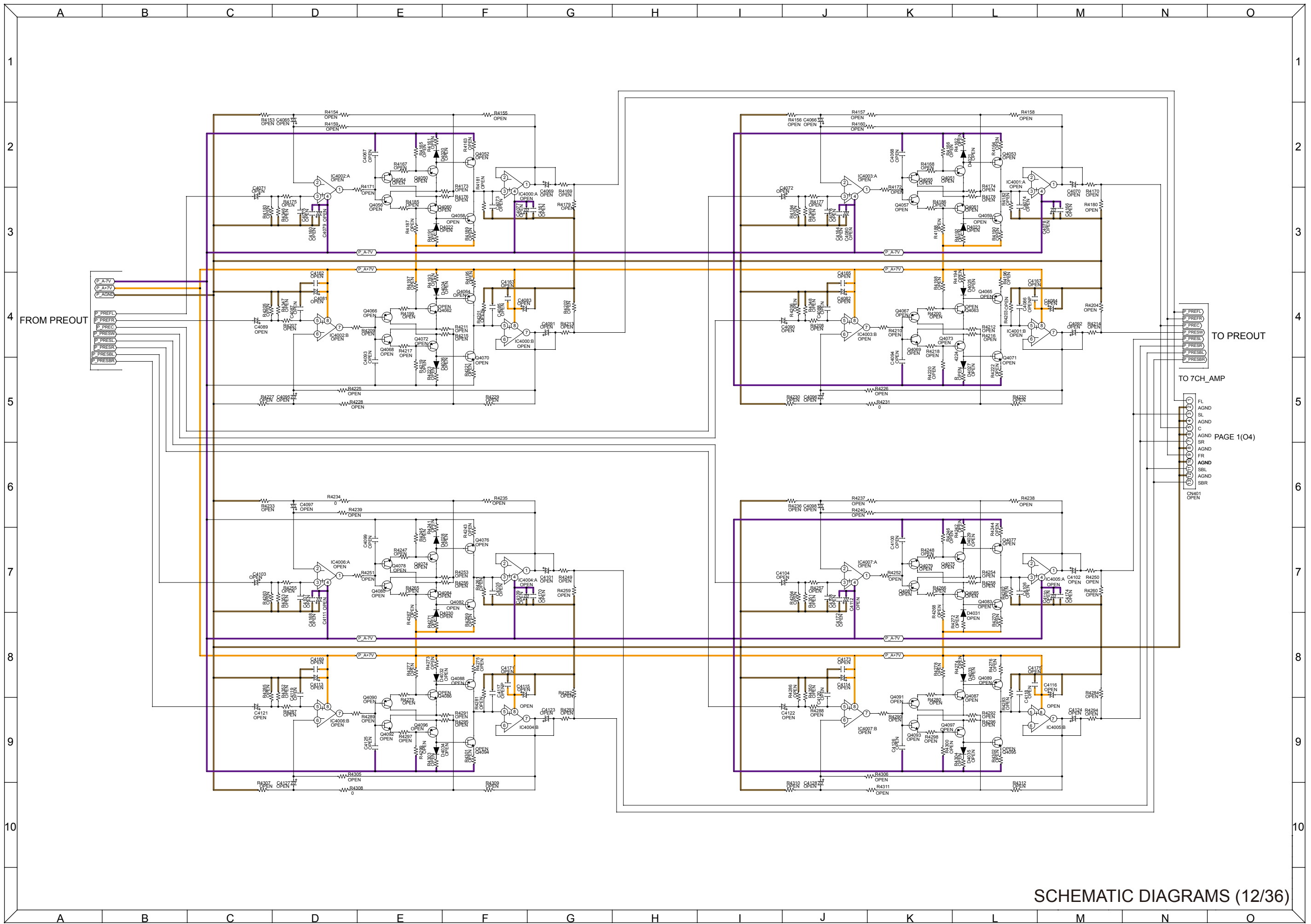

SCHEMATIC DIAGRAMS (12/36)



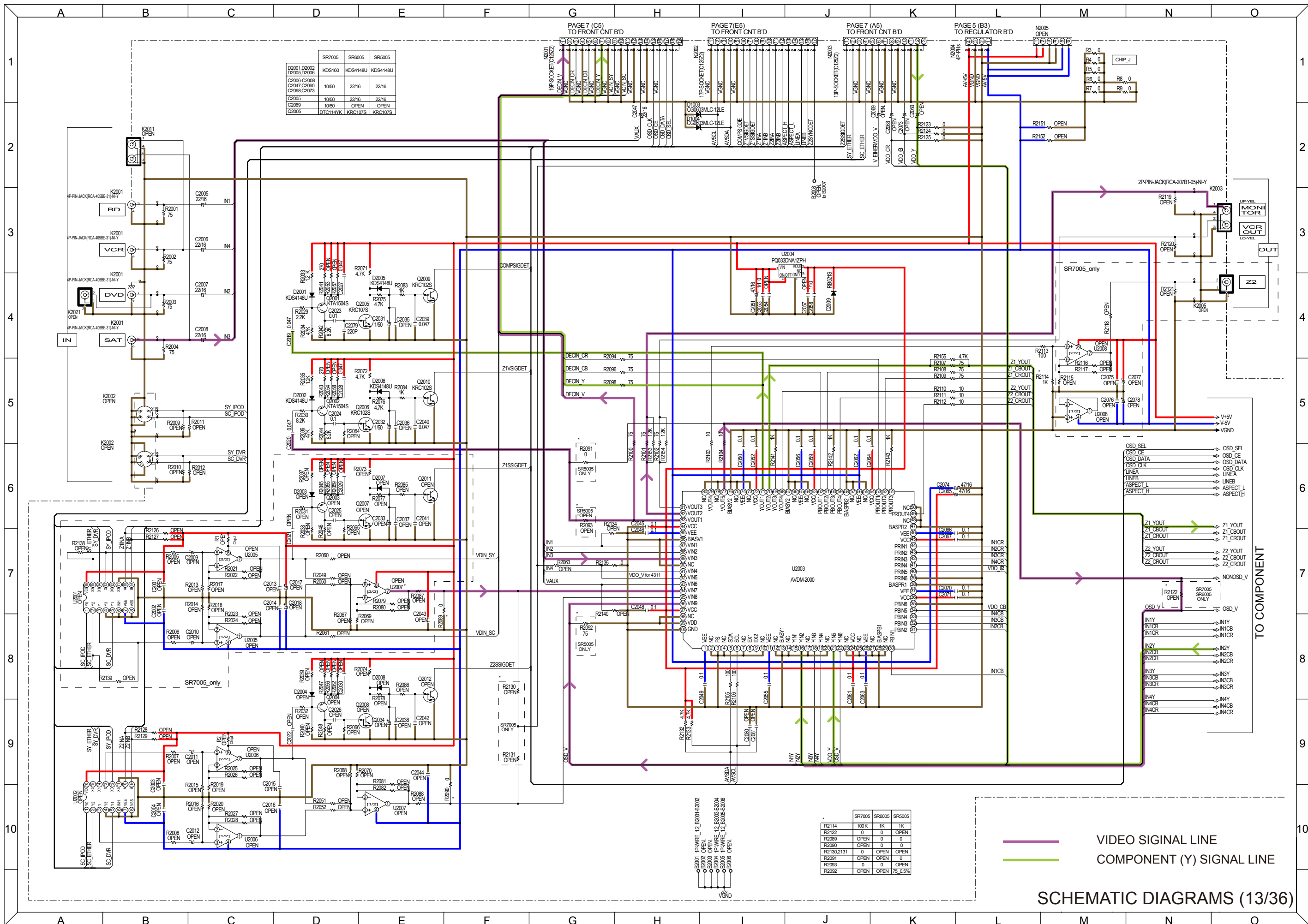

**SCHEMATIC DIAGRAMS (13/36)**

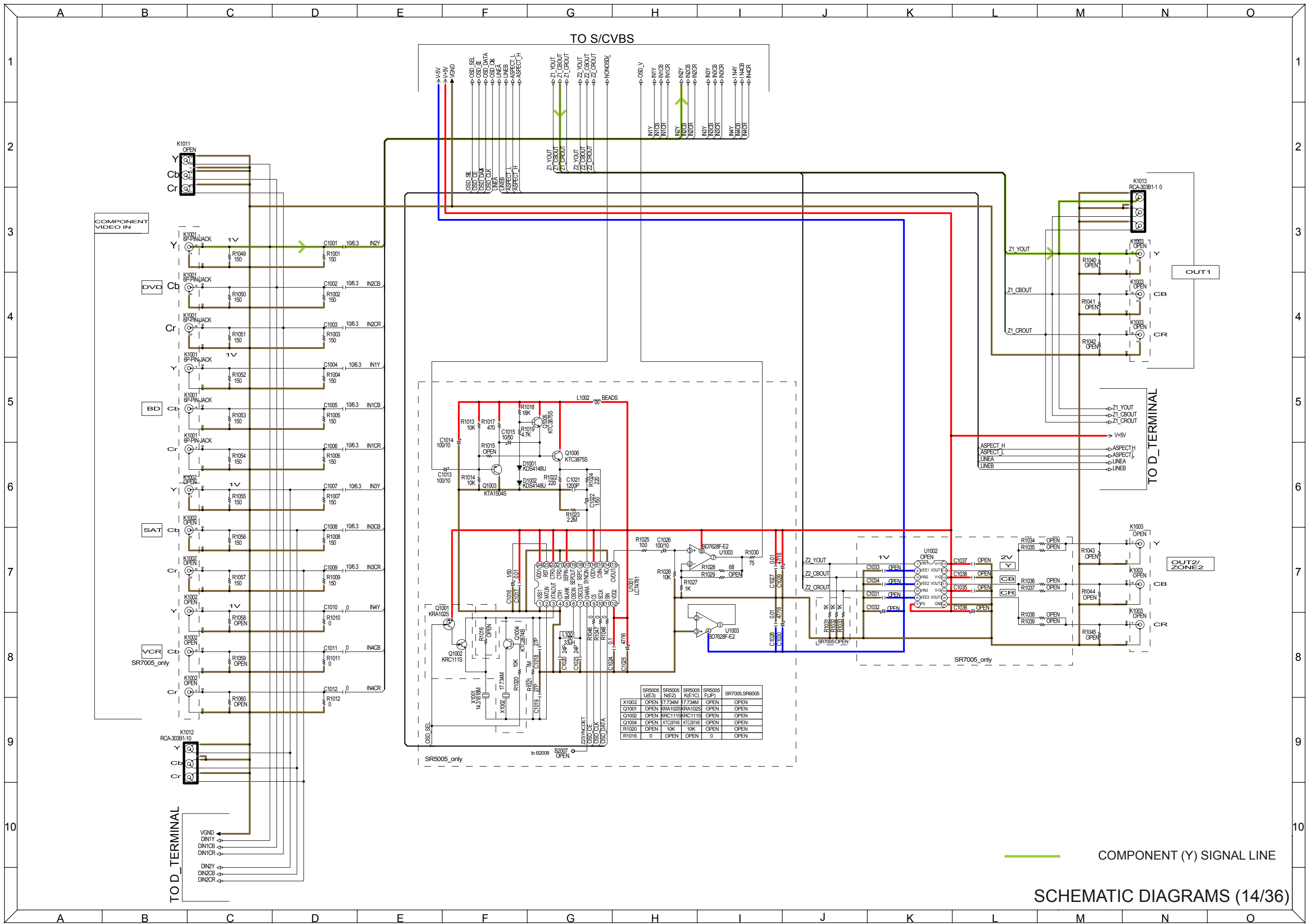

SCHMATIC DIAGRAMS (14/36)

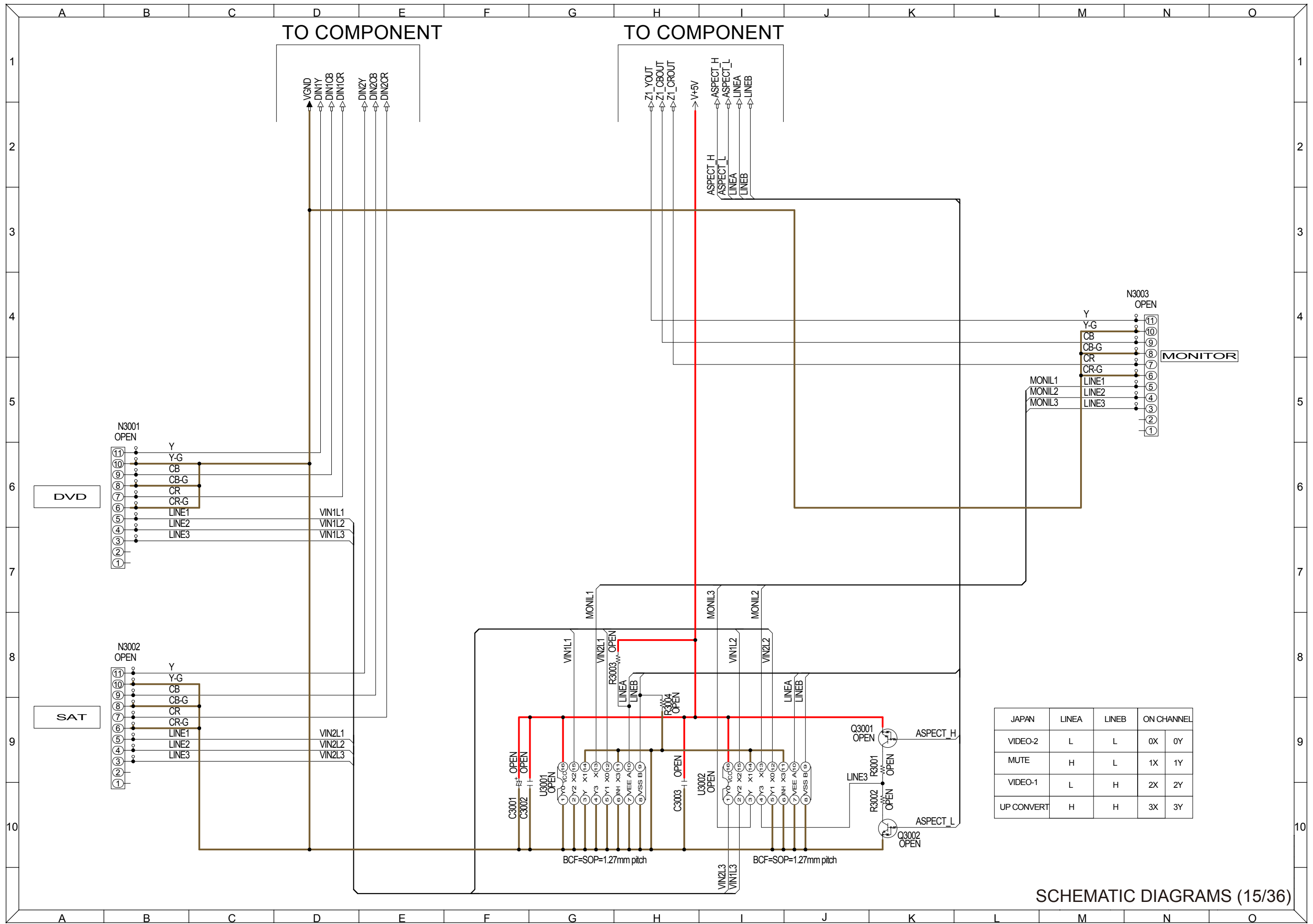

JAPAN	LINEA	LINEB	ON CHANNEL	
VIDEO-2	L	L	0X	0Y
MUTE	H	L	1X	1Y
VIDEO-1	L	H	2X	2Y
UP CONVERT	H	H	3X	3Y

SCHEMATIC DIAGRAMS (15/36)

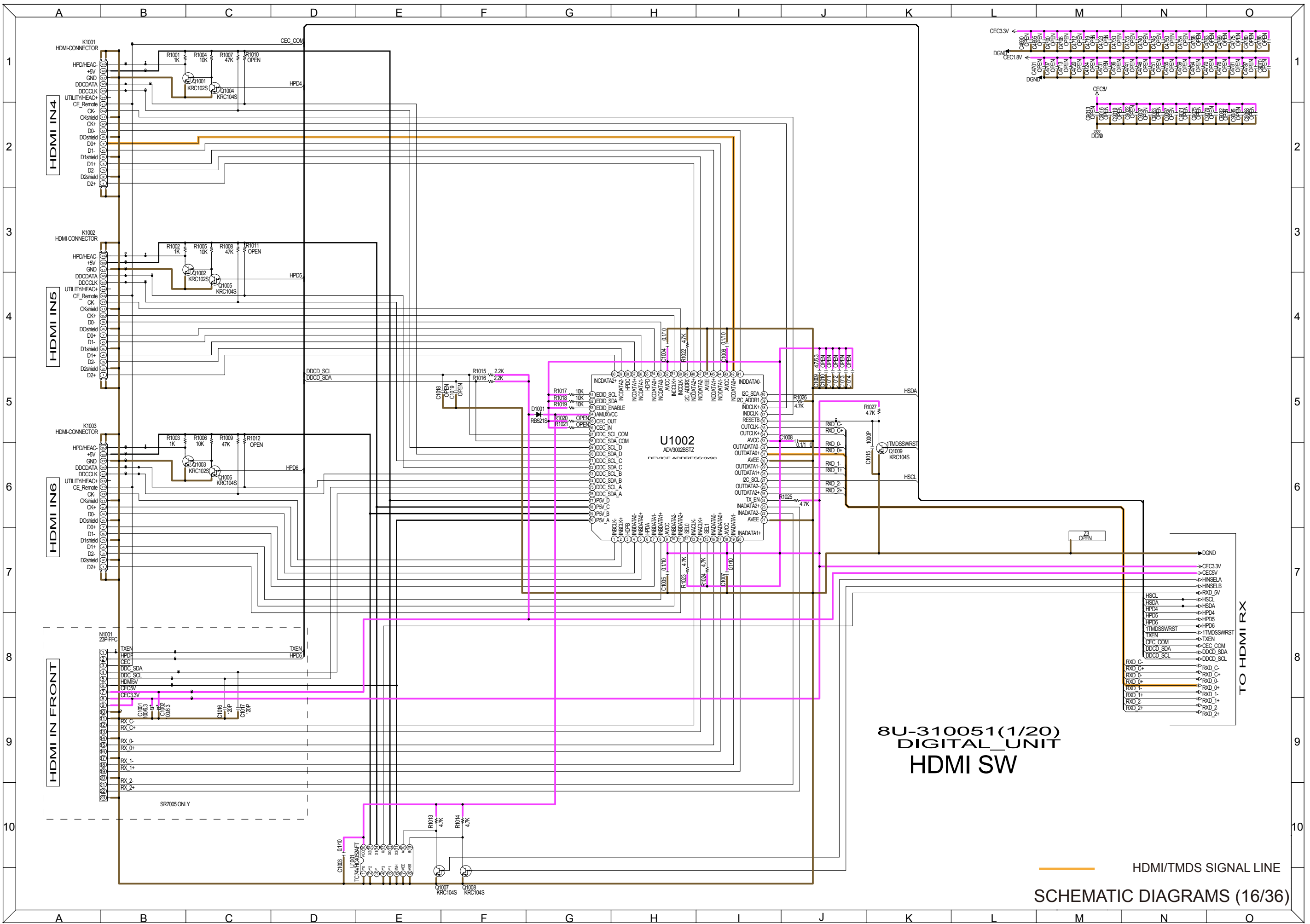

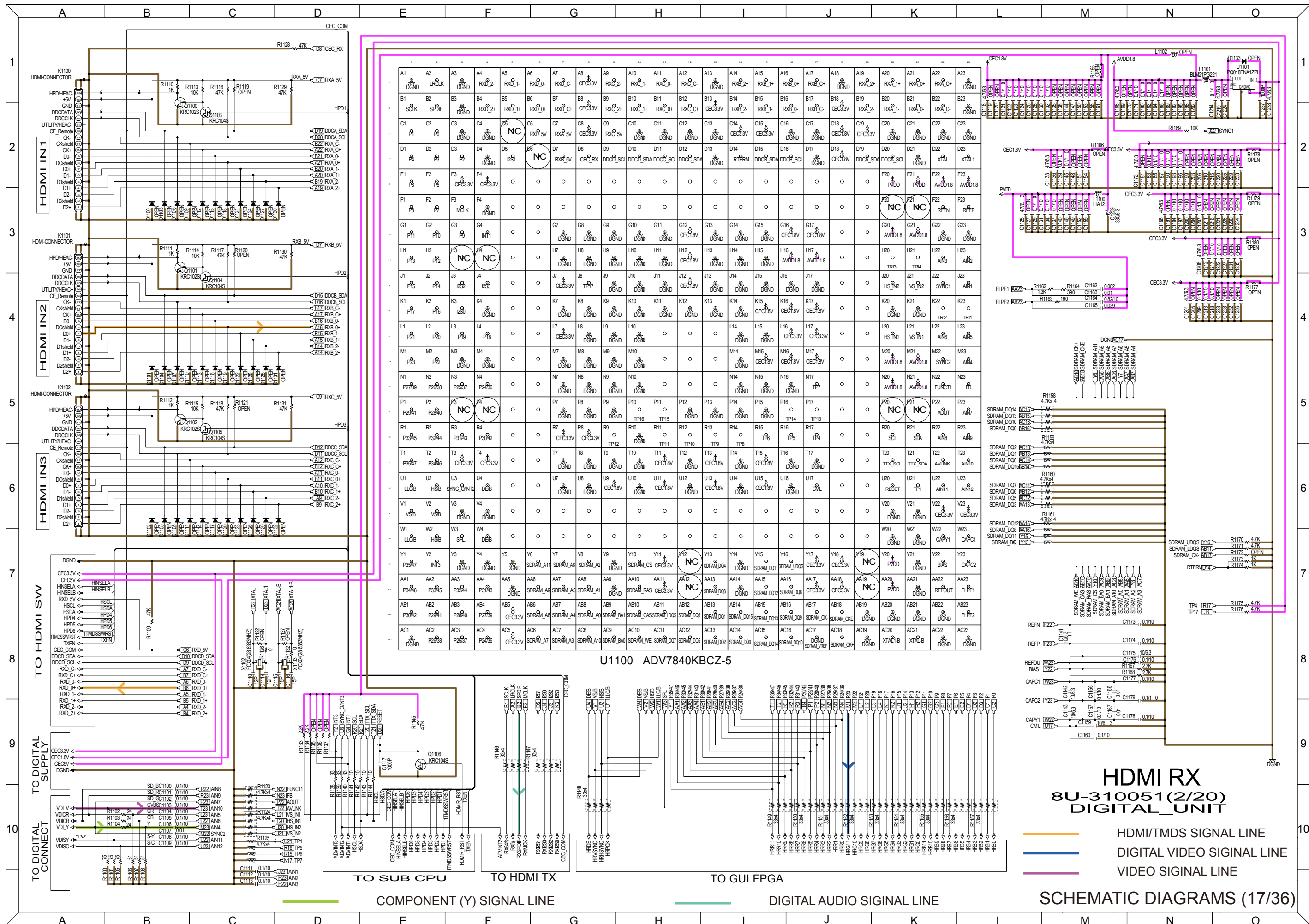

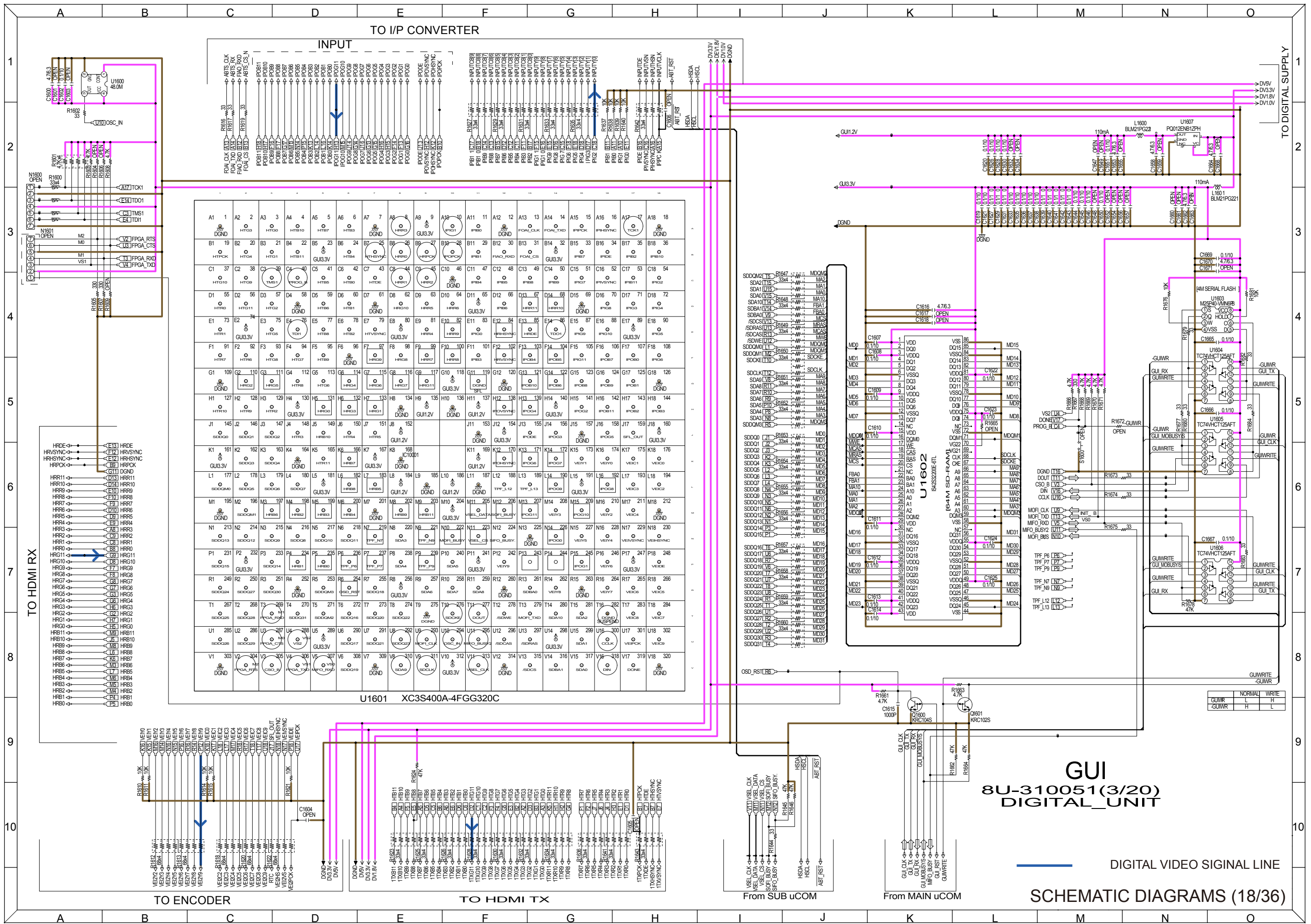

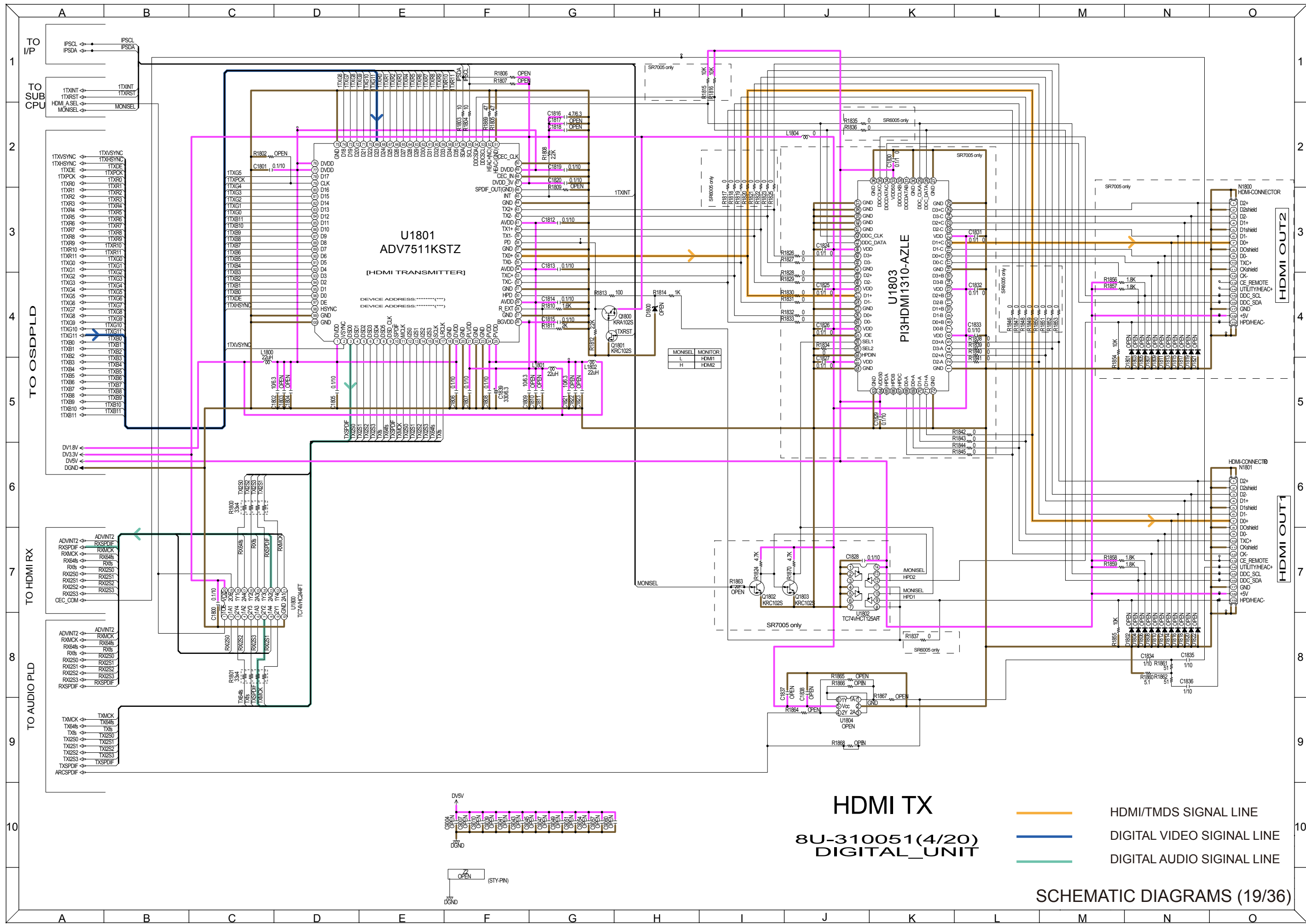

SCHMATIC DIAGRAMS (19/36)

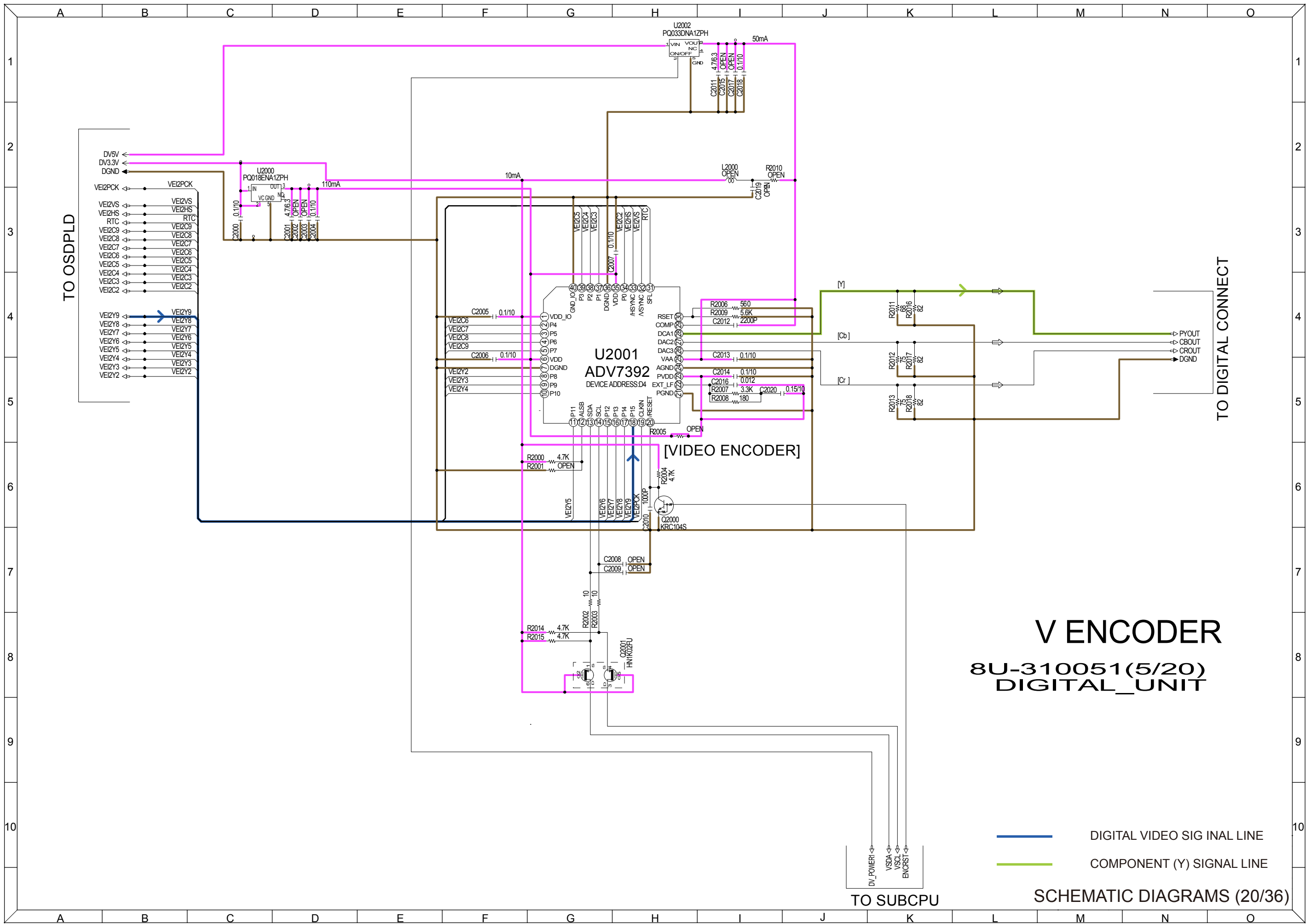



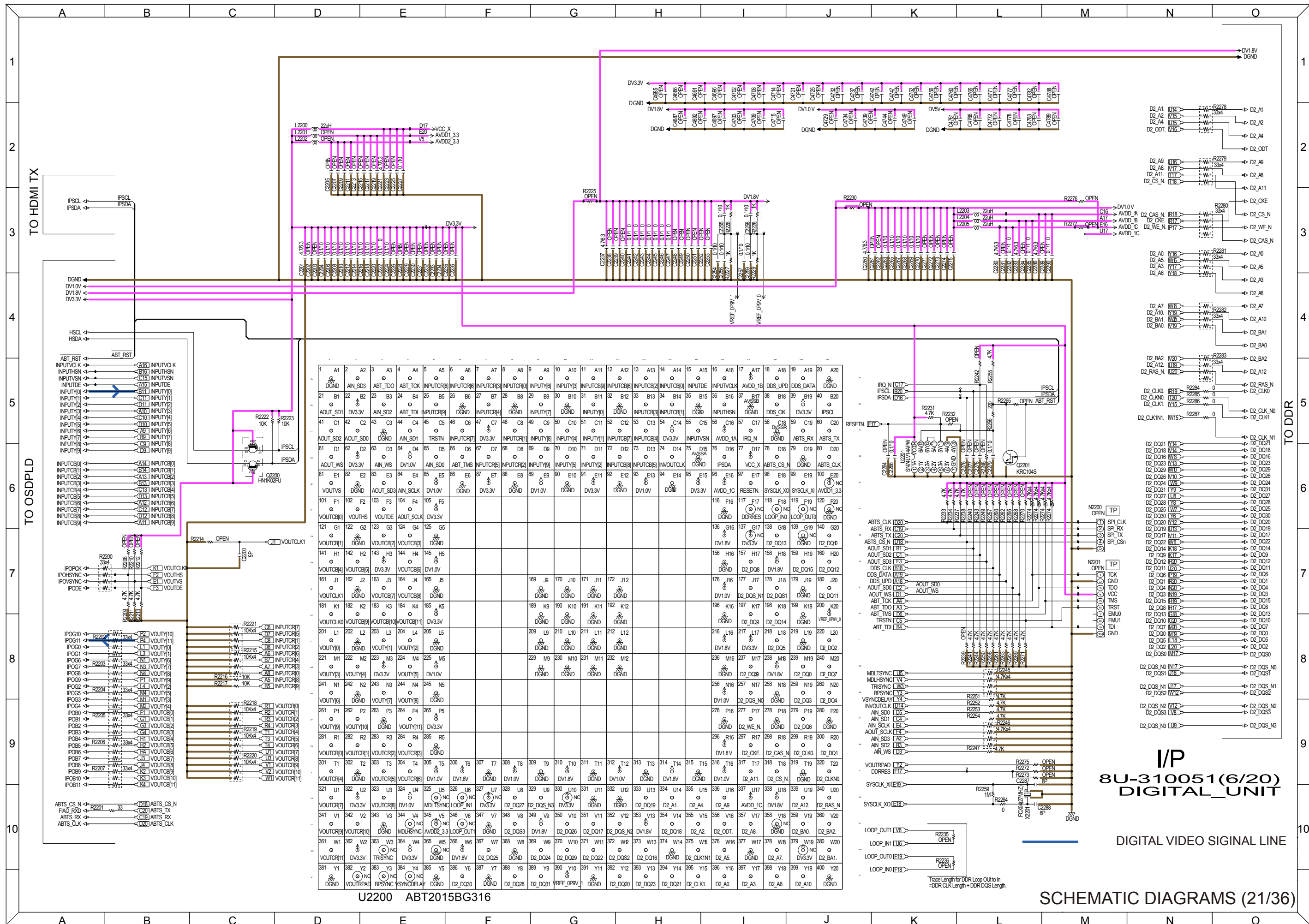

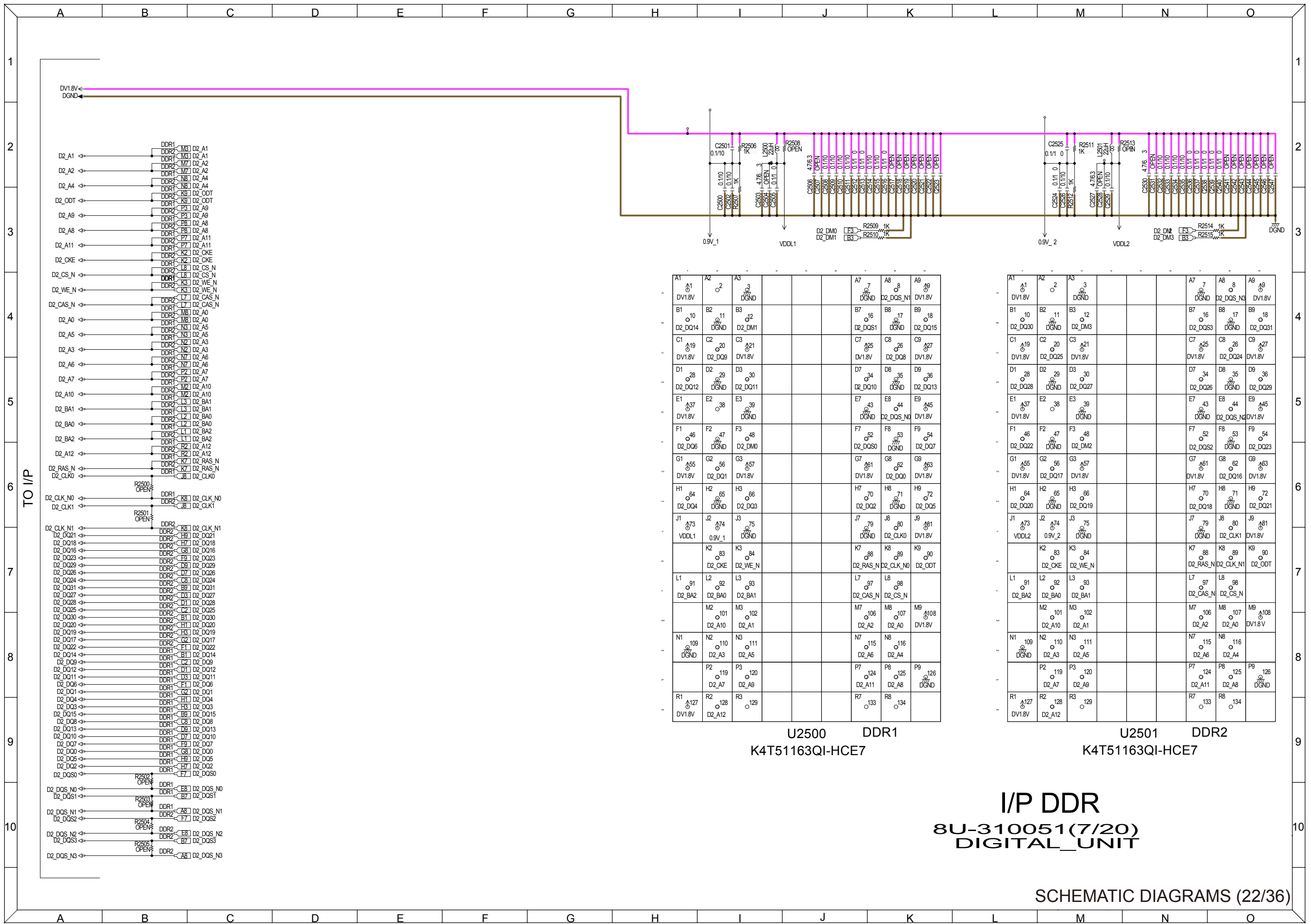

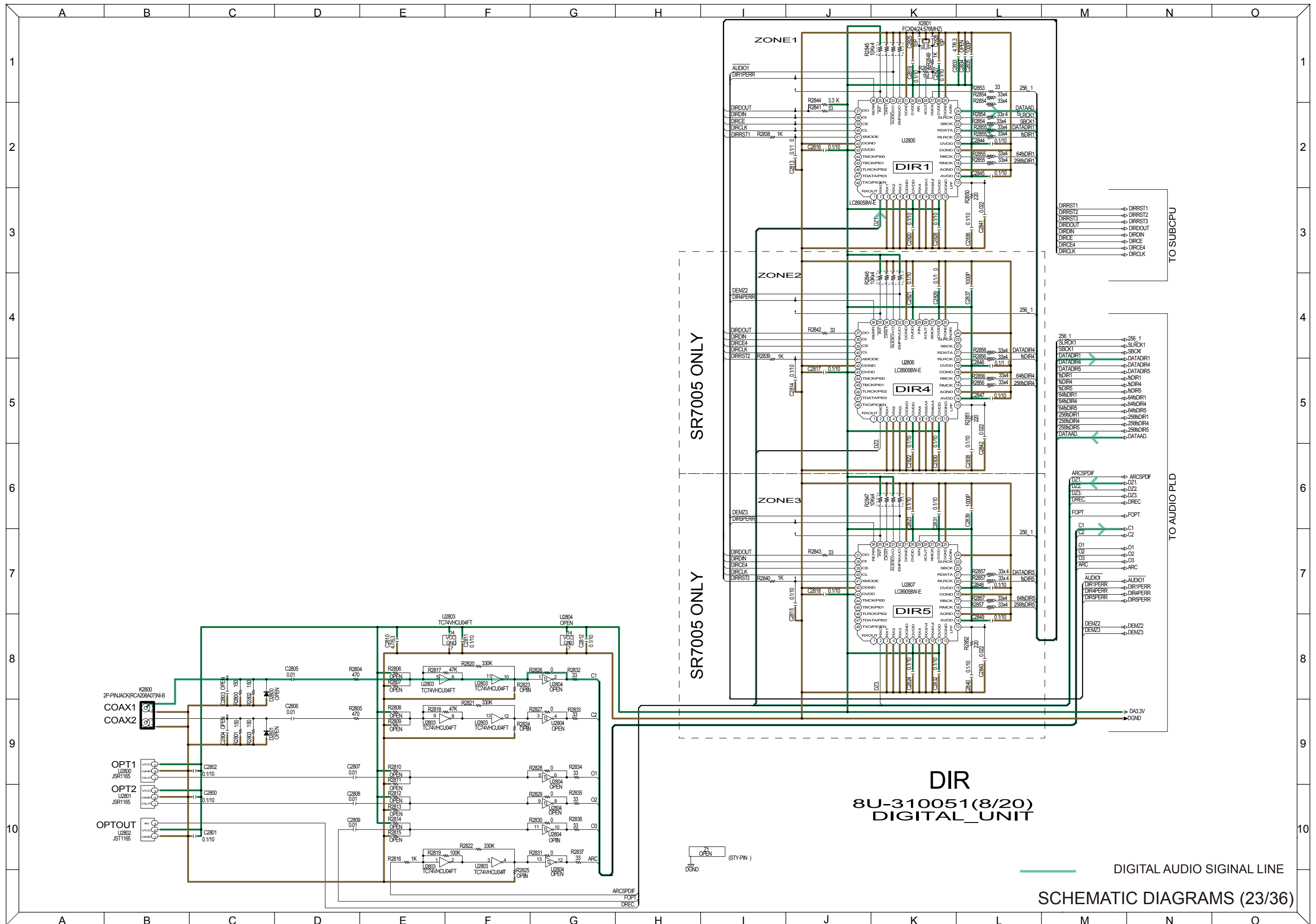

SCHMATIC DIAGRAMS (23/36)

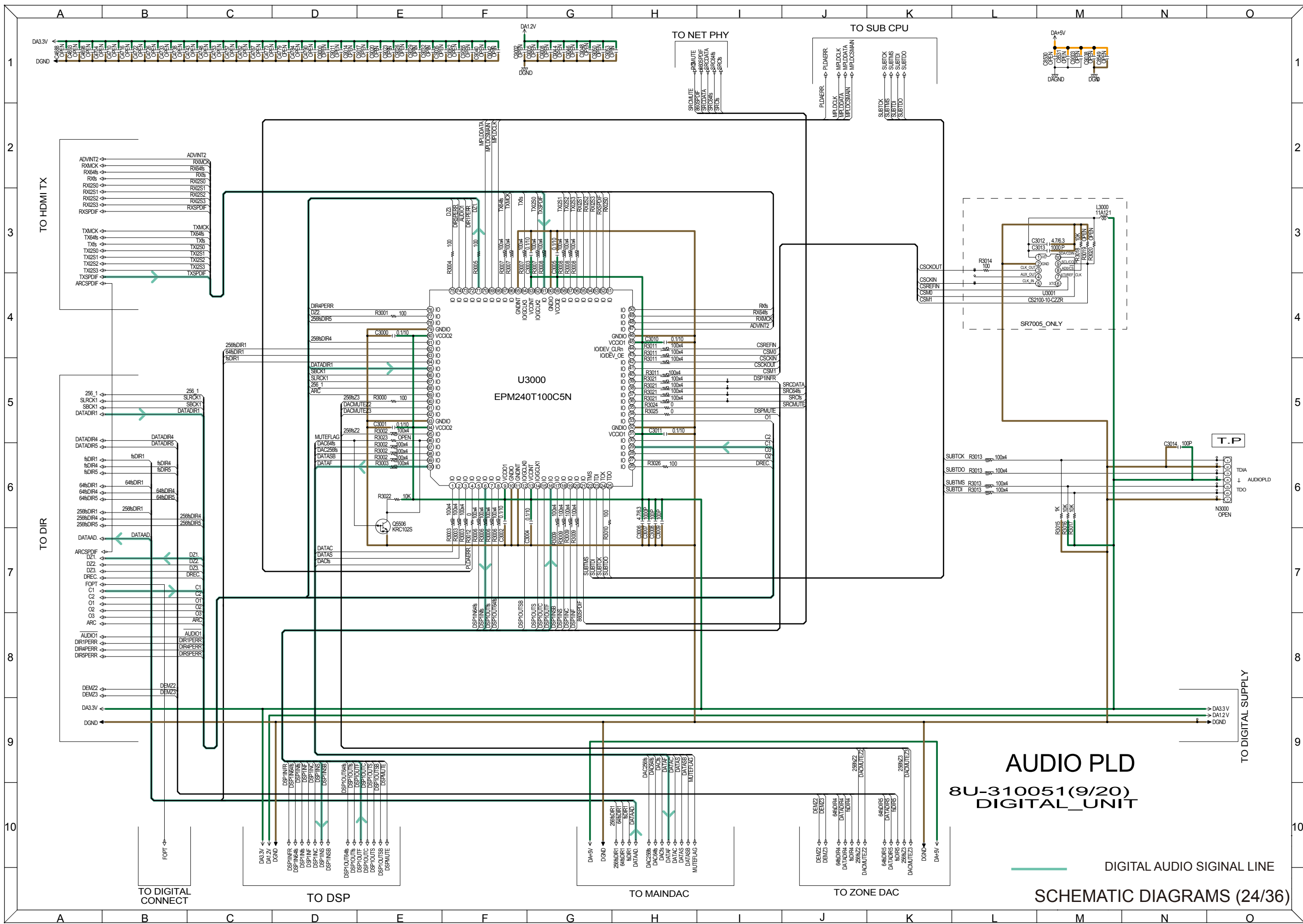

**AUDIO PLD**  
**8U-310051 (9/20)**  
**DIGITAL\_UNIT**

— DIGITAL AUDIO SIGNAL LINE

**SCHEMATIC DIAGRAMS (24/36)**

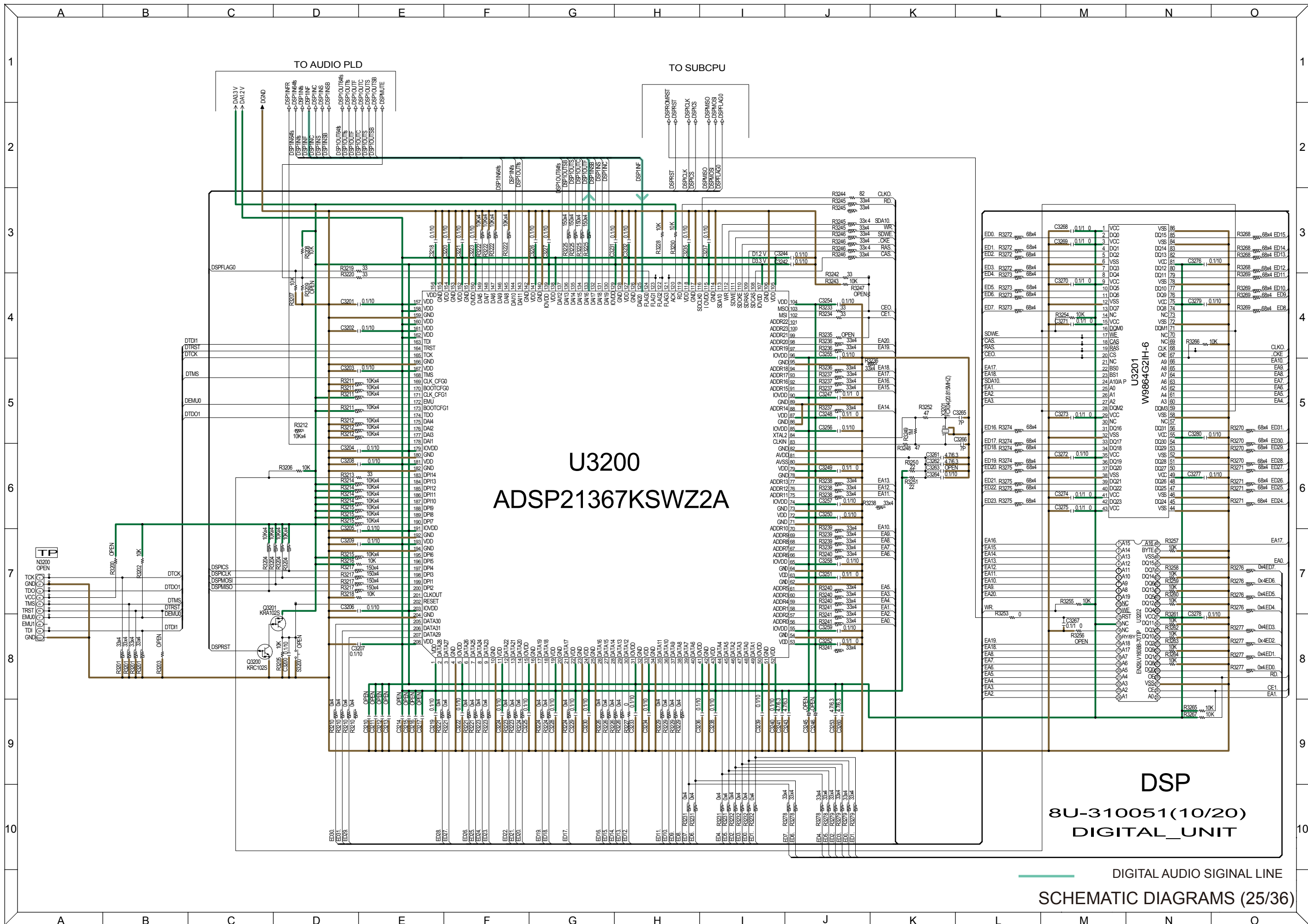

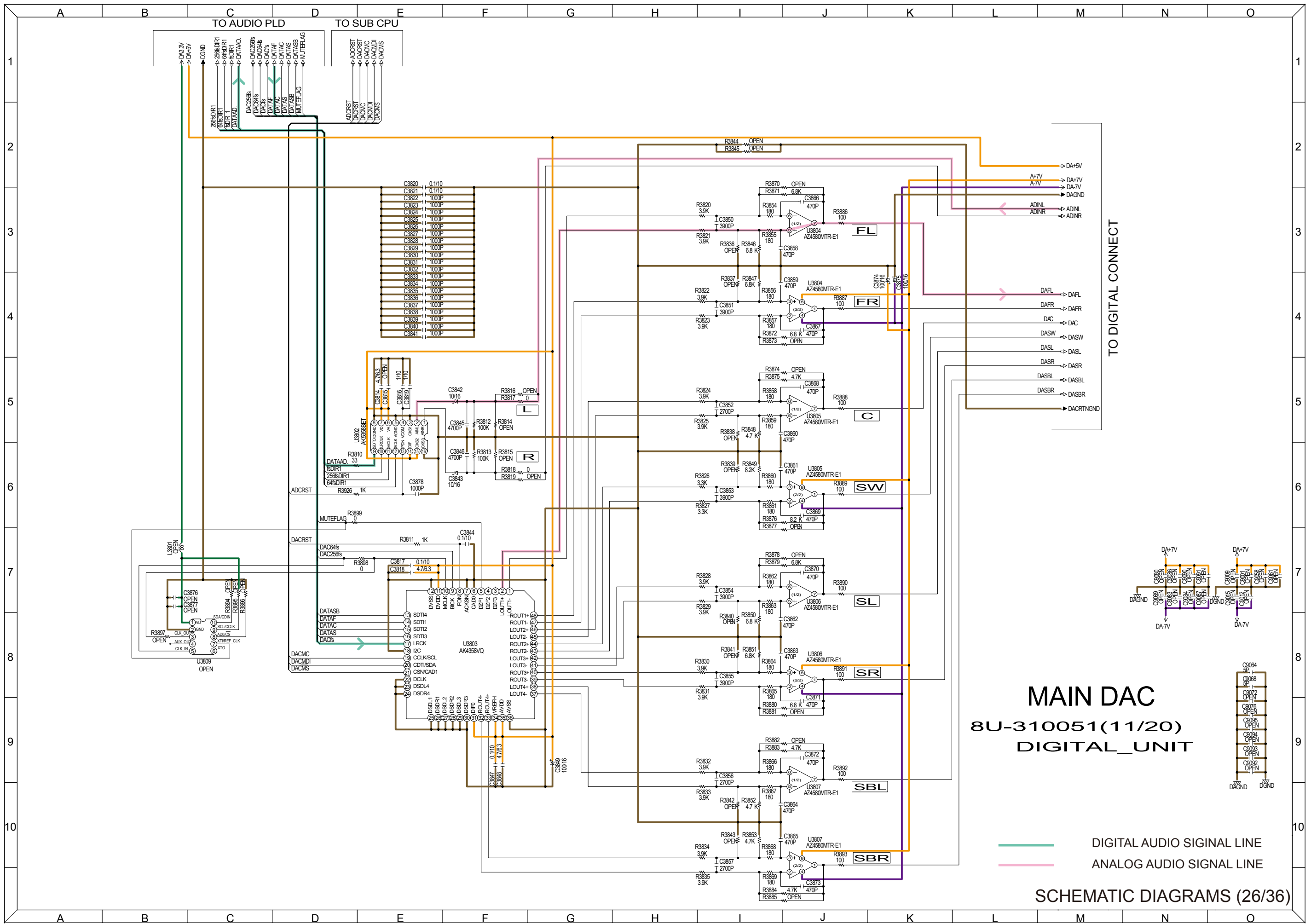

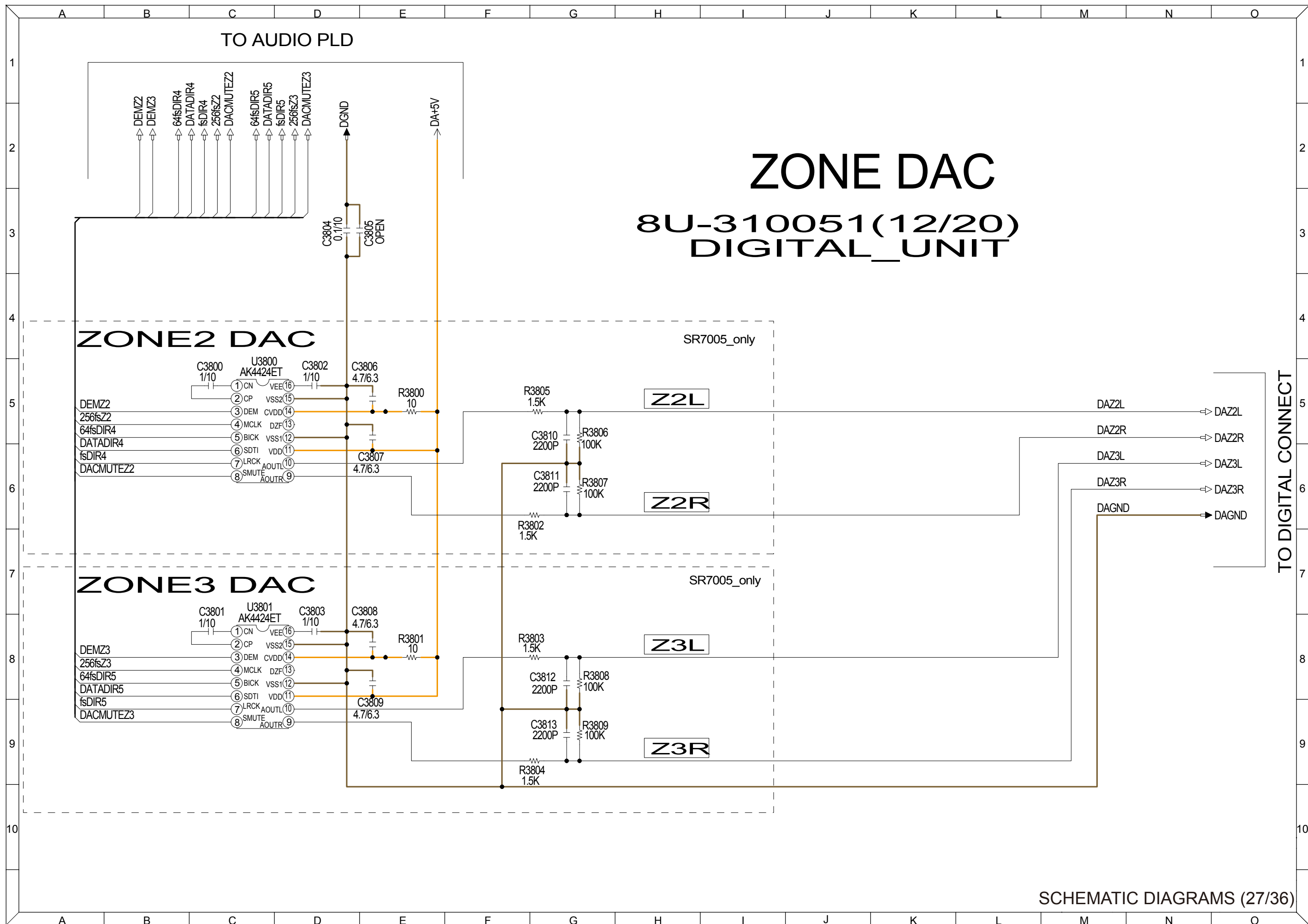

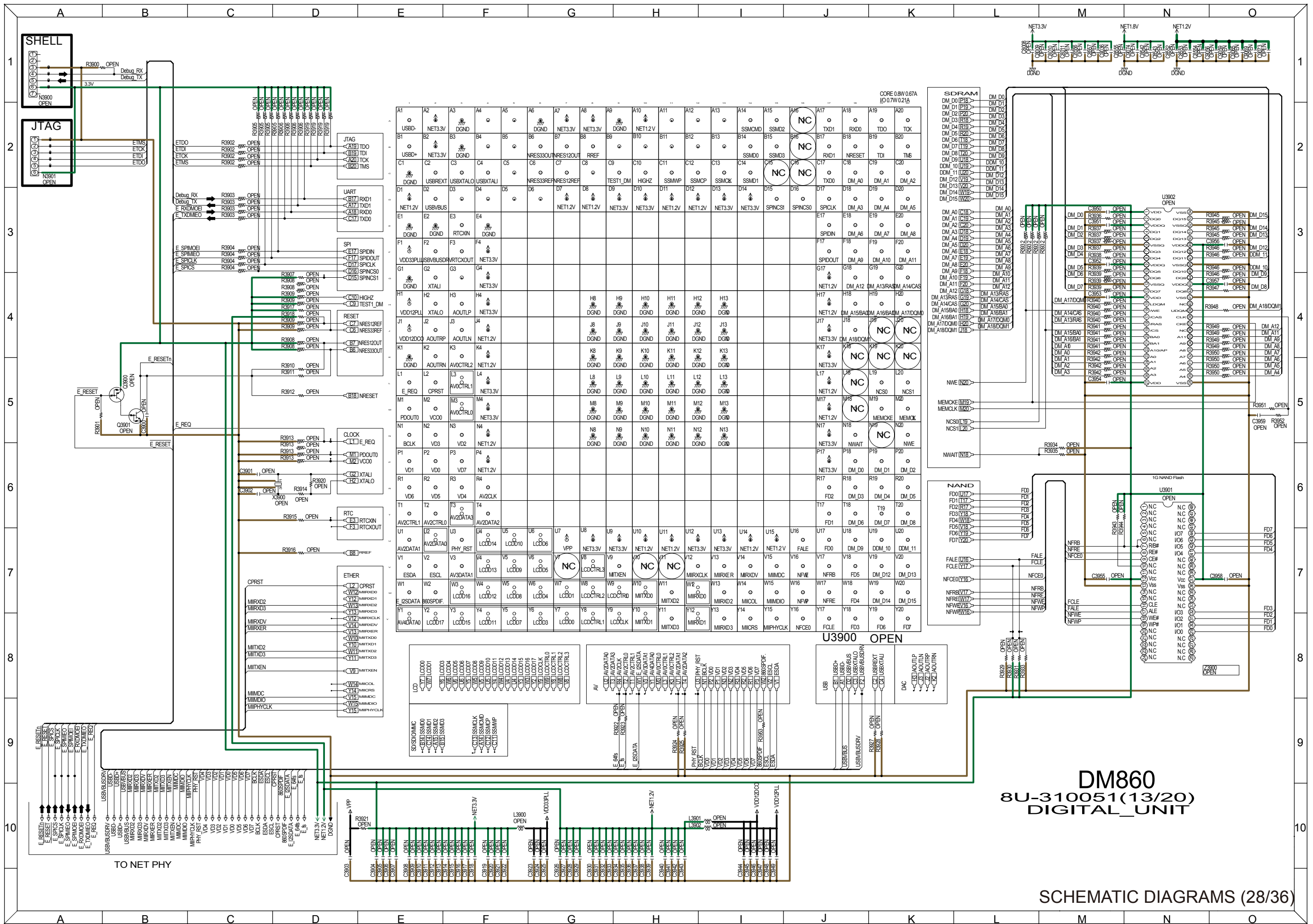

**DM860  
8U-310051(13/20)  
DIGITAL\_UNIT**

**SCHEMATIC DIAGRAMS (28/36)**



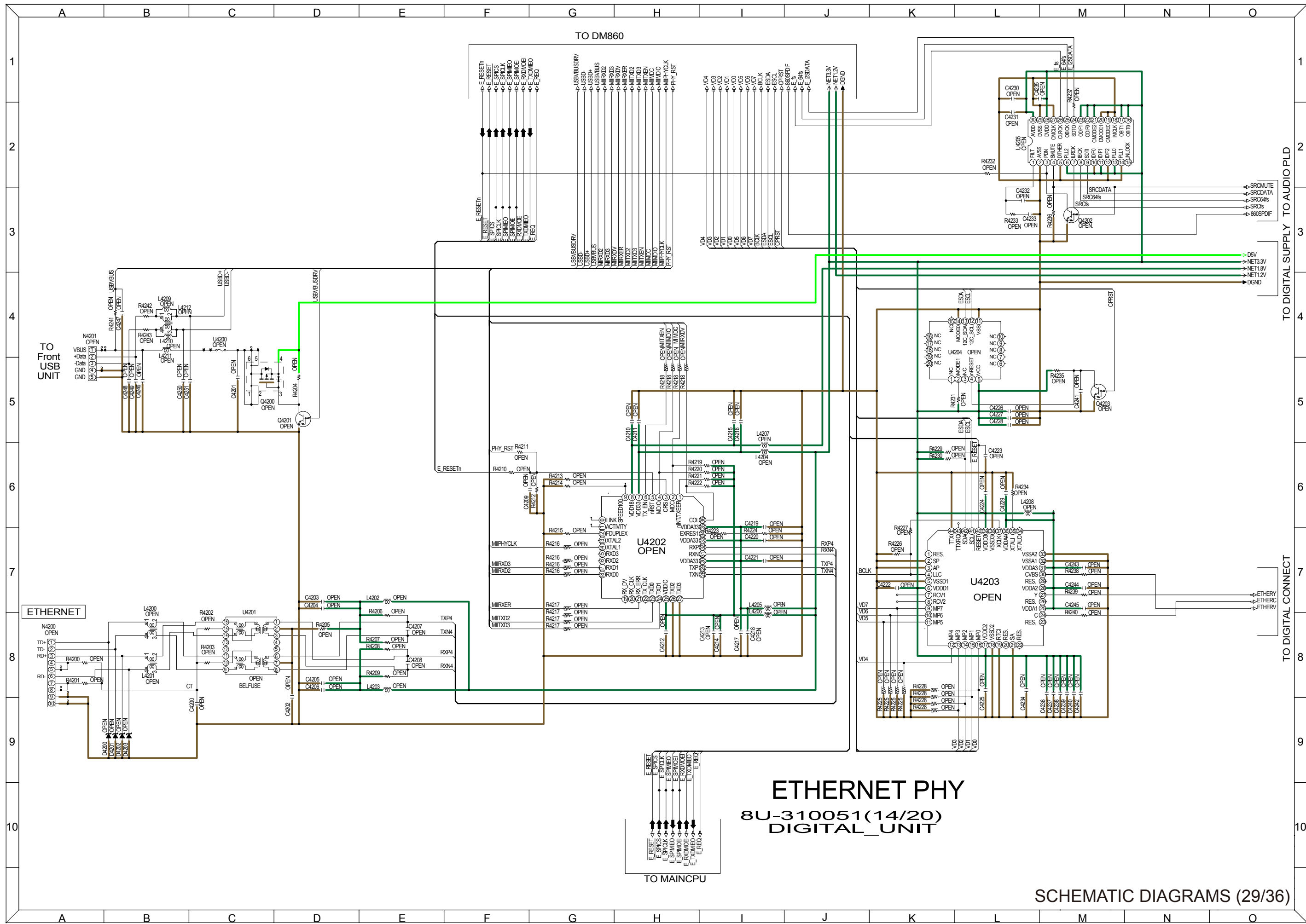

**ETHERNET PHY**  
**8U-310051(14/20)**  
**DIGITAL\_UNIT**

# USB TCC8600

## 8U-310051(15/20)

### DIGITAL\_UNIT

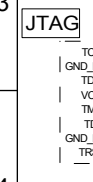

TO MAIN CPU

TO DIGITAL SUPPLY

TO DIGITAL CONNECT

TO Front USB UNIT

**U4403**  
**TCC8600**

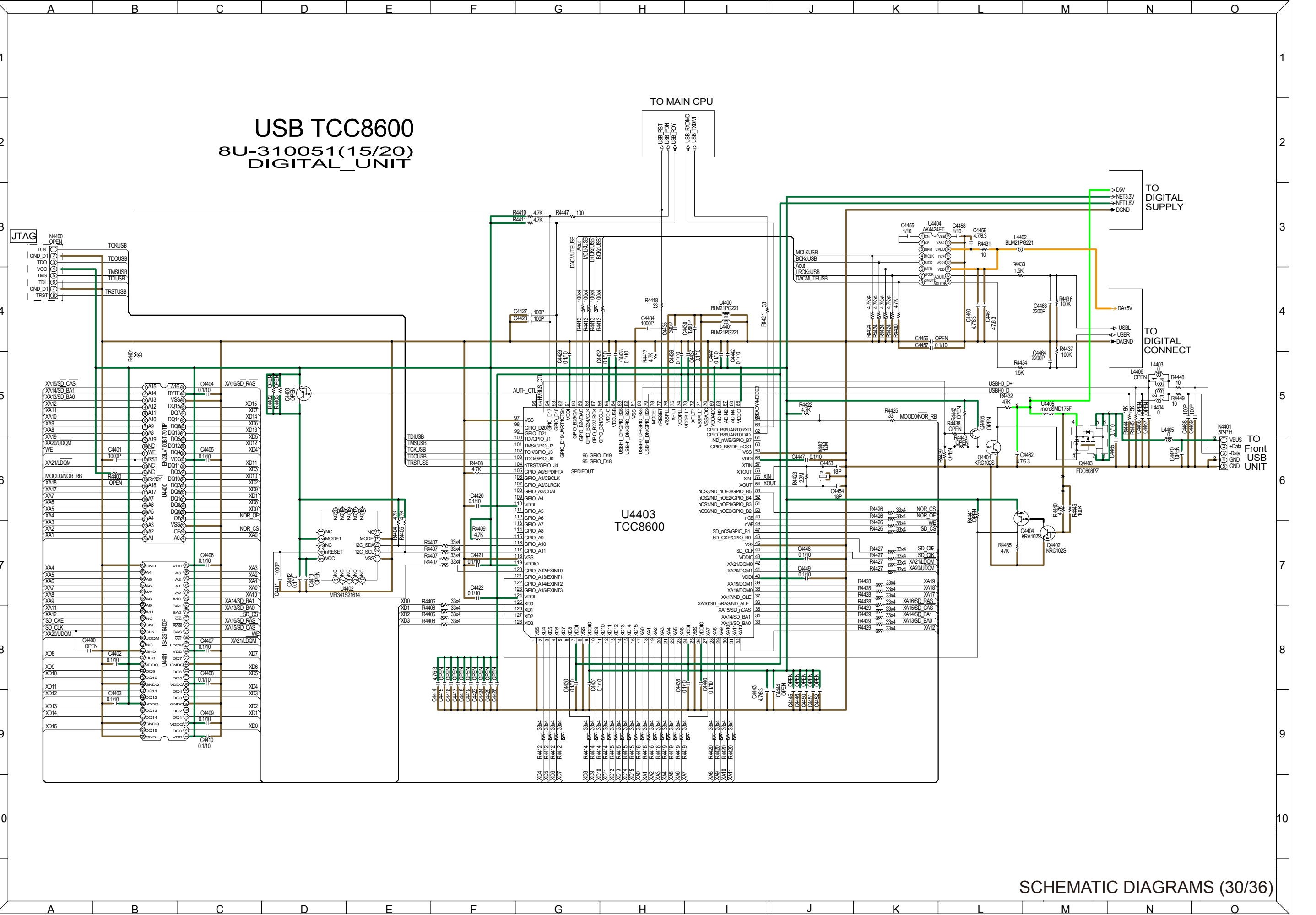

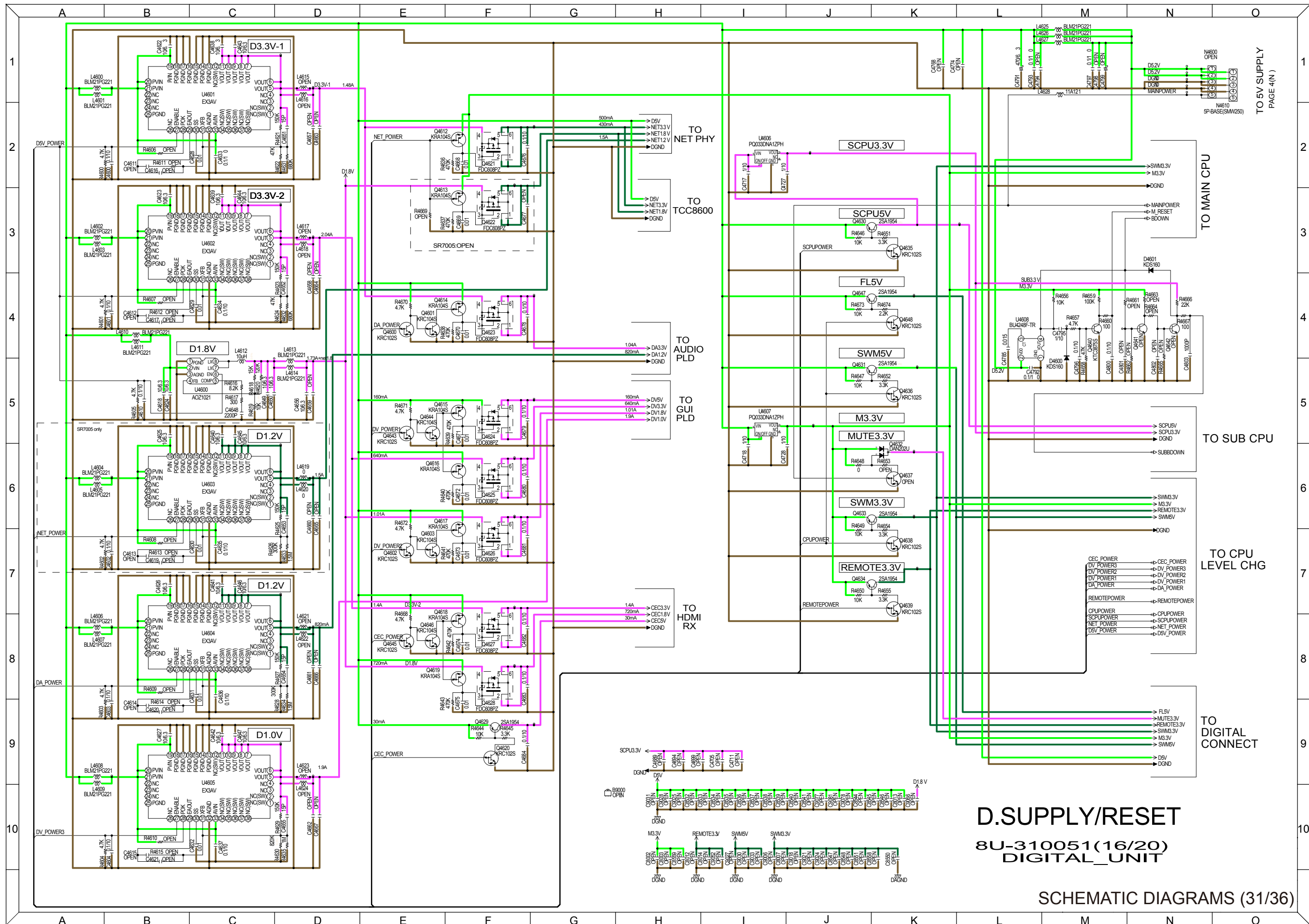

**D.SUPPLY/RESET**  
**8U-310051(16/20)**  
**DIGITAL\_UNIT**

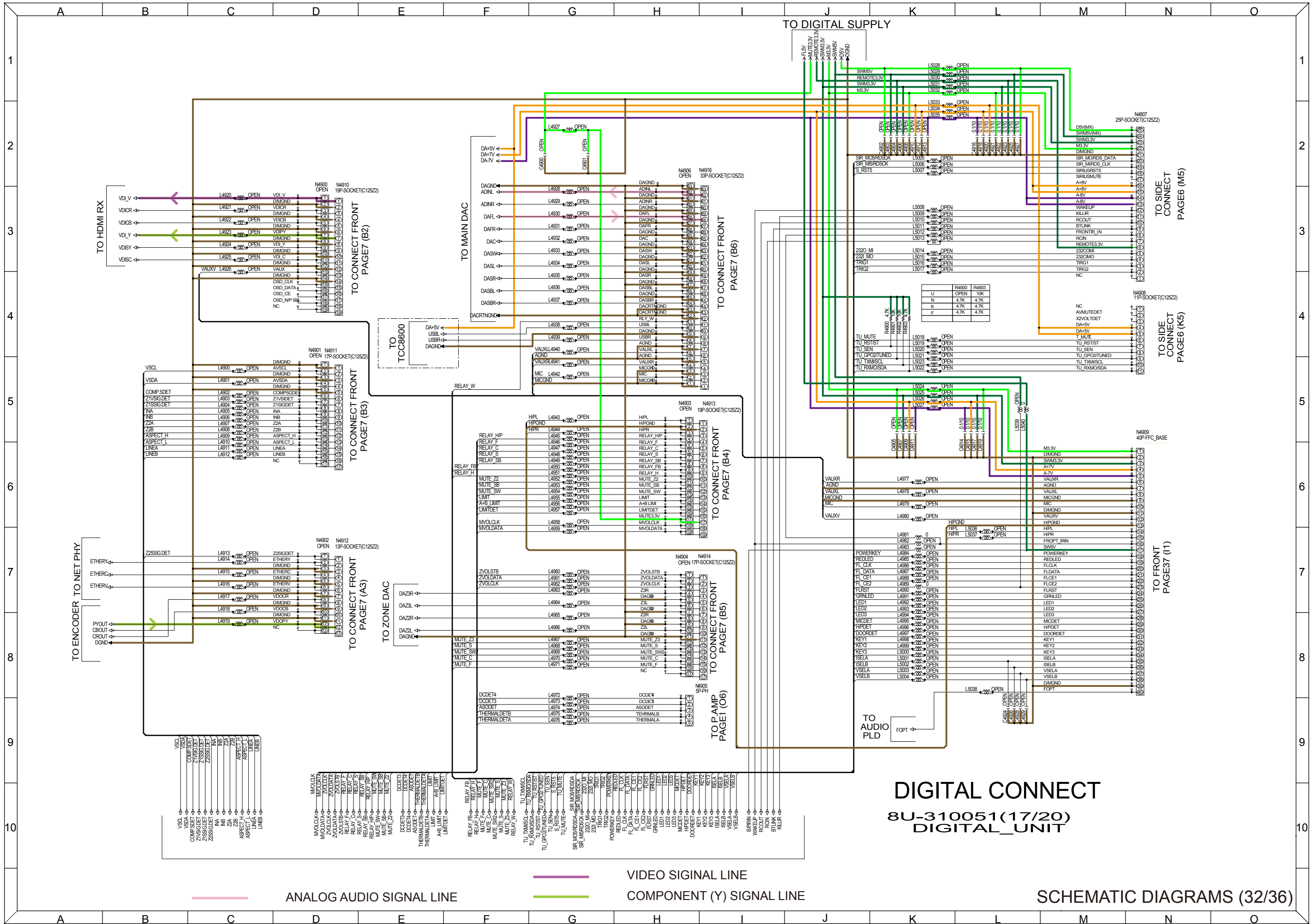

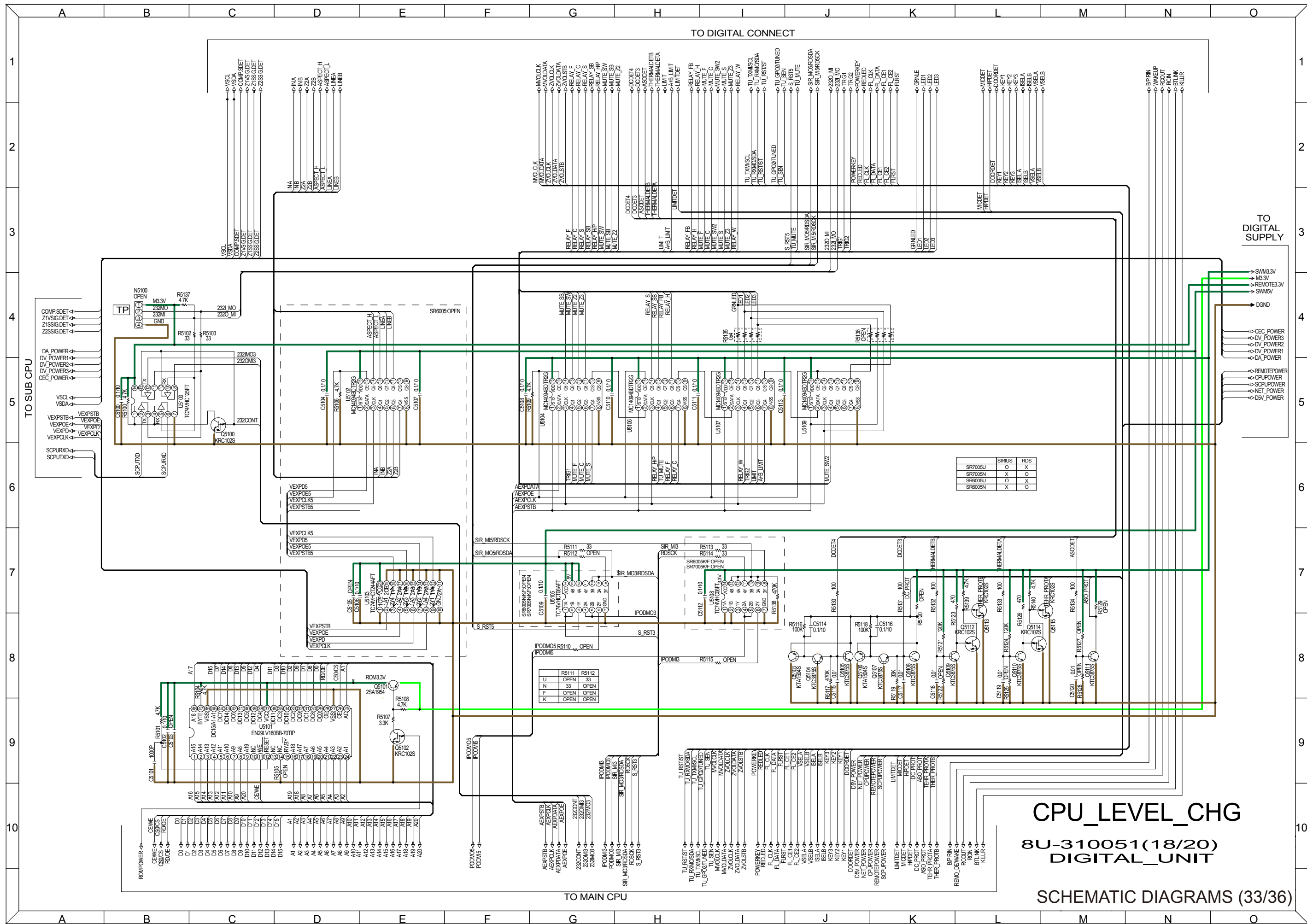

	SIRUS	RDS
SR7005U	0	X
SR7005N	X	0
SR6005U	0	X
SR6005N	X	0

	R5111	R5112
U	OPEN	33
N	OPEN	OPEN
F	OPEN	OPEN
K	OPEN	OPEN

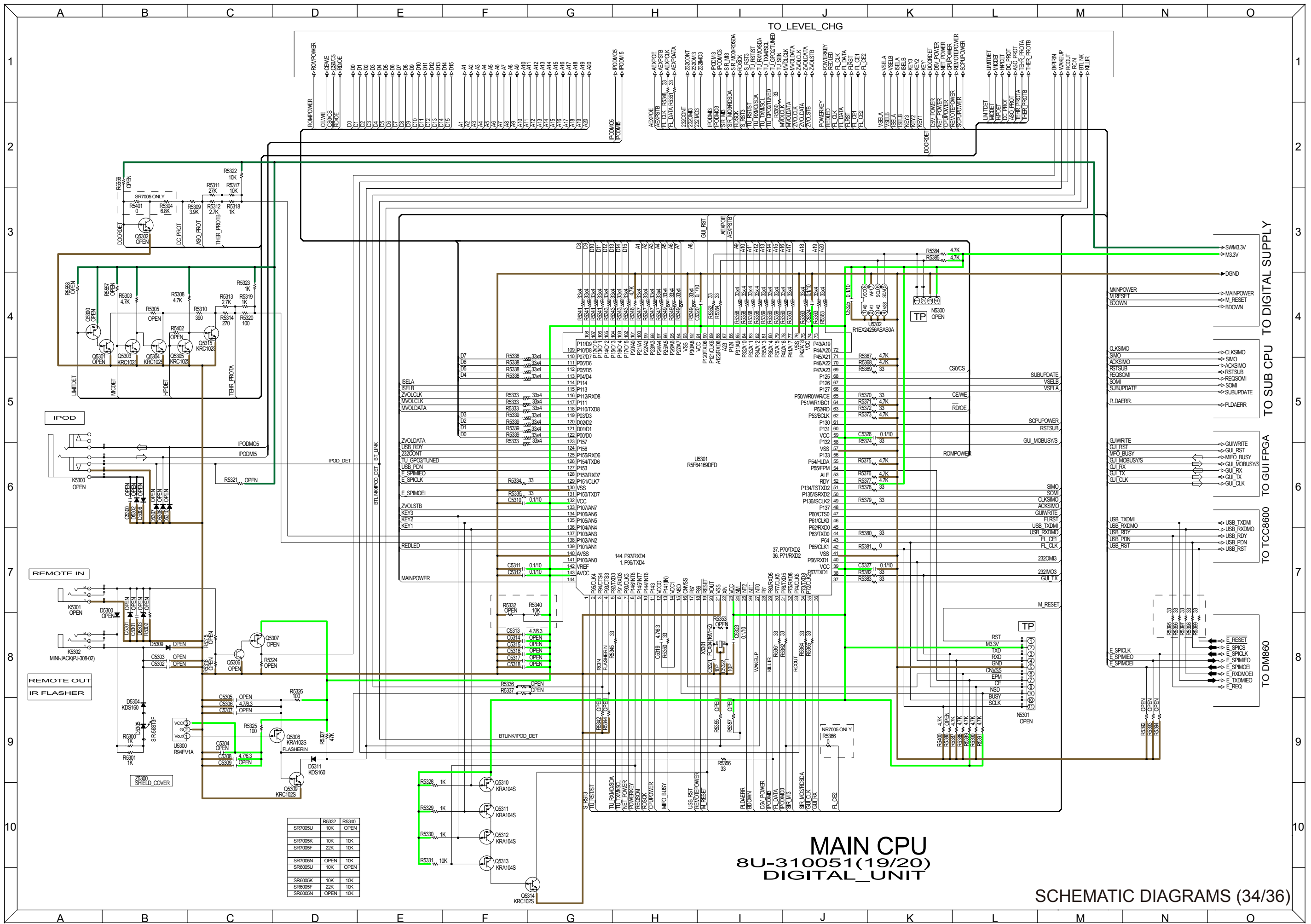

**MAIN CPU  
8U-310051(19/20)  
DIGITAL\_UNIT**

**SCHEMATIC DIAGRAMS (34/36)**

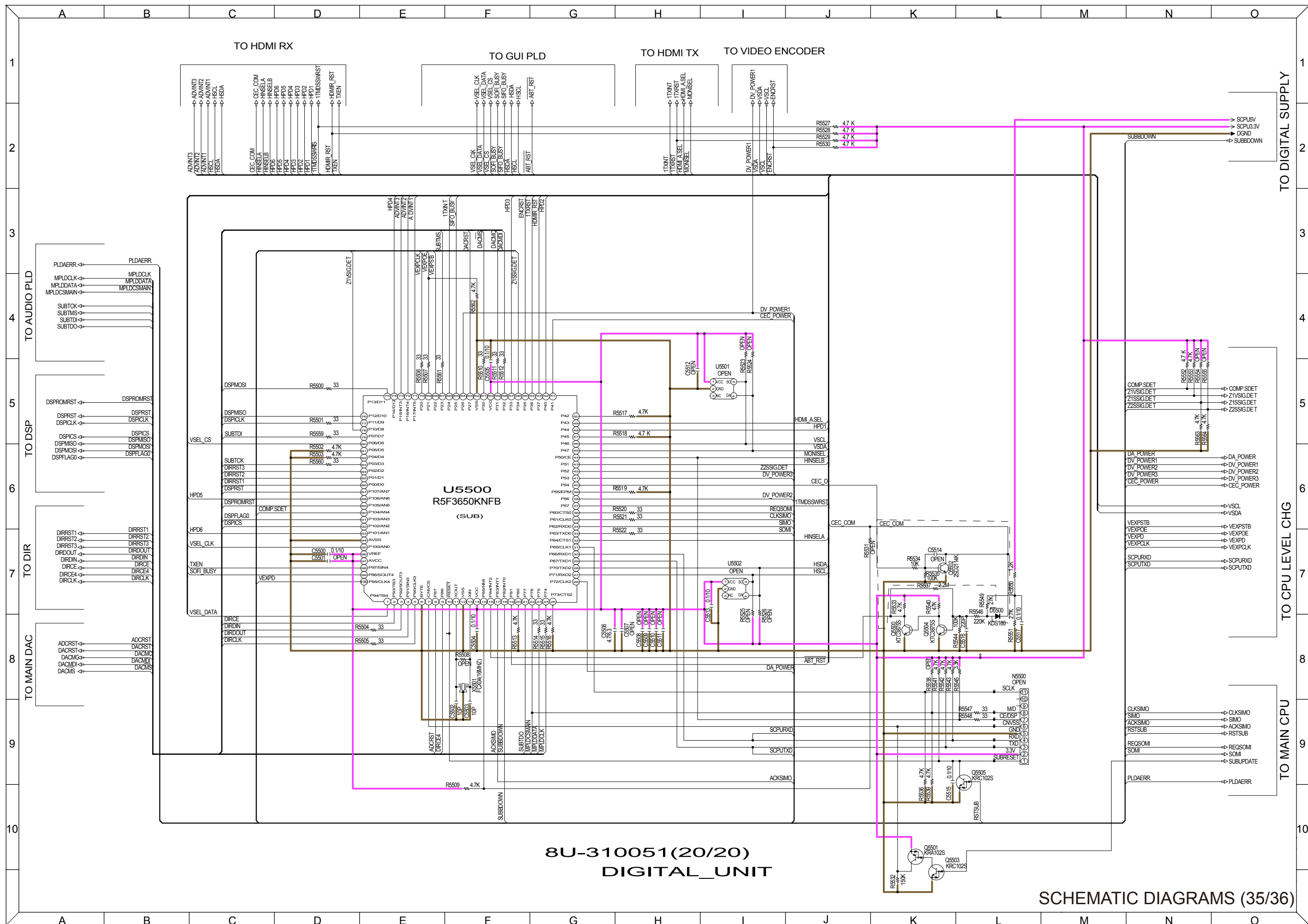

SCHMATIC DIAGRAMS (35/36)

# FRONT B'D

FLT301 OPEN

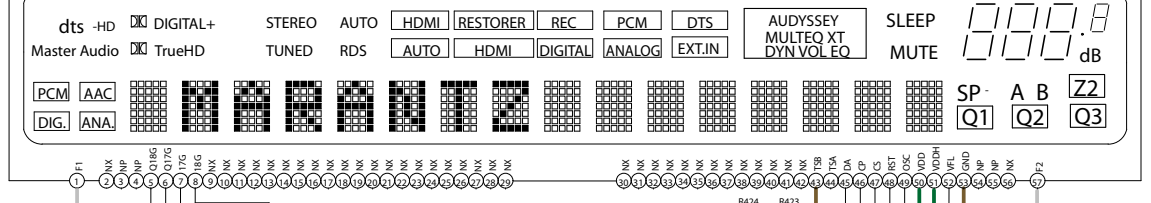

	SR5005	SR6005
FLT301	USE	USE
FLT302	USE	USE
ZD301	6.8V	7.5V
ZD303	Forward	Reverse
ZD304	Forward/16V	Reverse/24V
D321	Forward	Reverse
D322	Forward	Reverse
Q300	KSA916Y	KTC1027Y
C364	Forward	Reverse
C365	Forward	Reverse
C367	Forward	Reverse
R423	15K	12K
R424	15K	12K
R425	100	10
R426	100	10
R430	USE	USE
R431	USE	USE
R434	USE	USE
R435	USE	USE
C360	1000N	100N
C361	USE	USE
Q315	USE	KTC38755
R427	100	39K
R428	100	100K
R429	100	100K
R355	68R	2R2
R358	68R	2R2
R383	68R	2R2
R390	68R	2R2
R402	0	0
R415	0	0
R416	0	0

FLT302 19-ST-02GINK

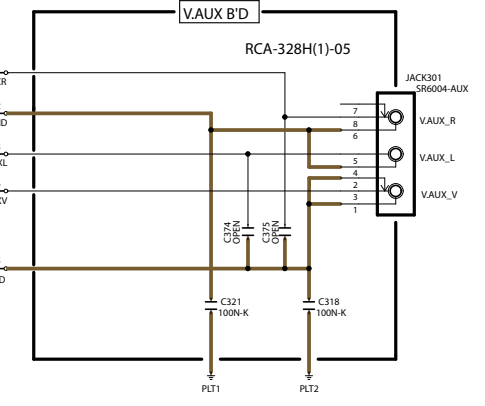
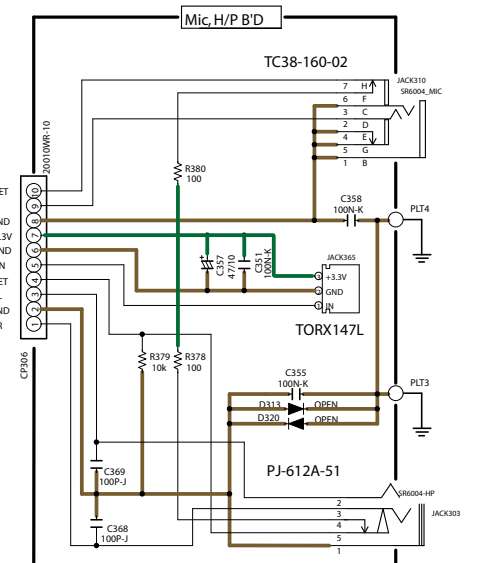
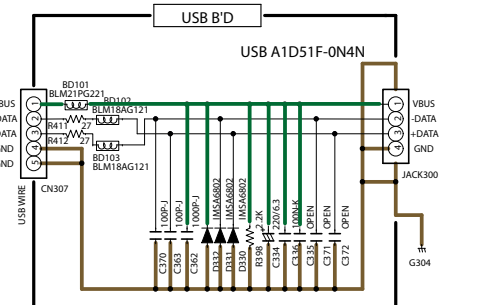
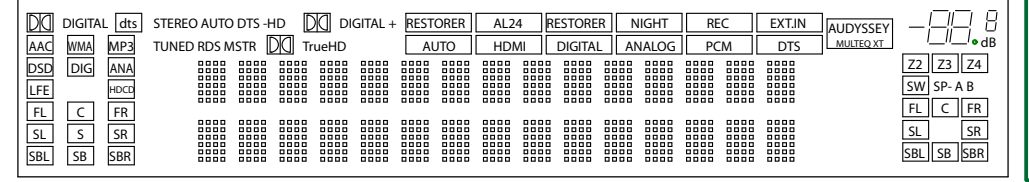

## SCHEMATIC DIAGRAMS (36/36)



# WIRING DIAGRAM

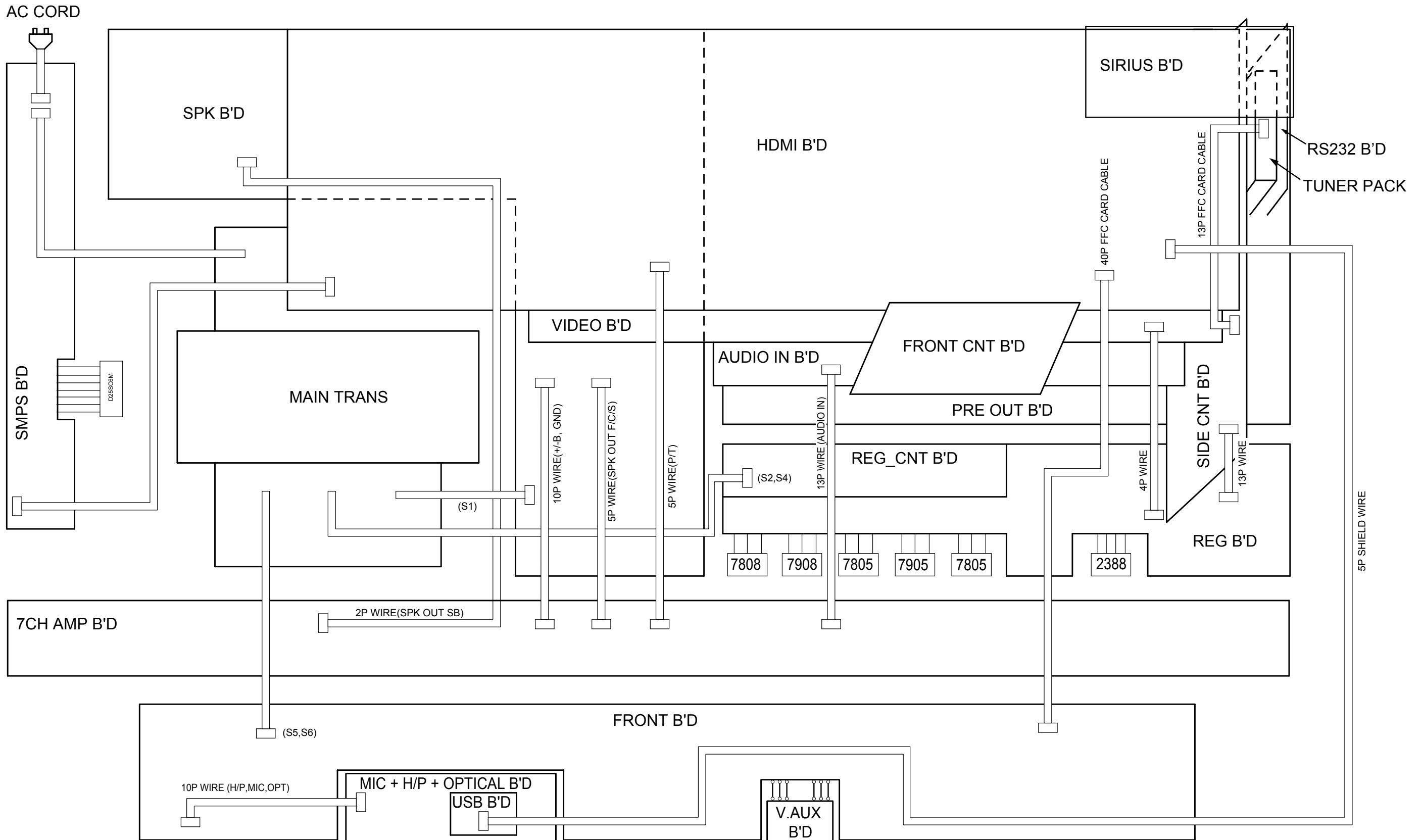

# EXPLODED VIEW

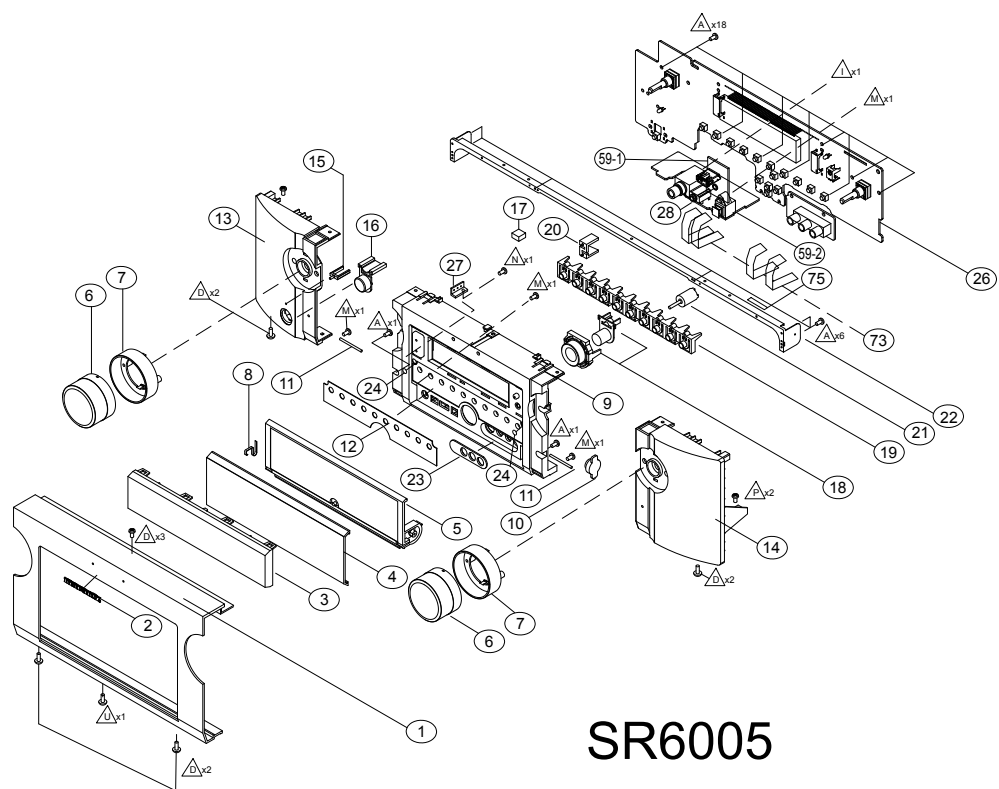
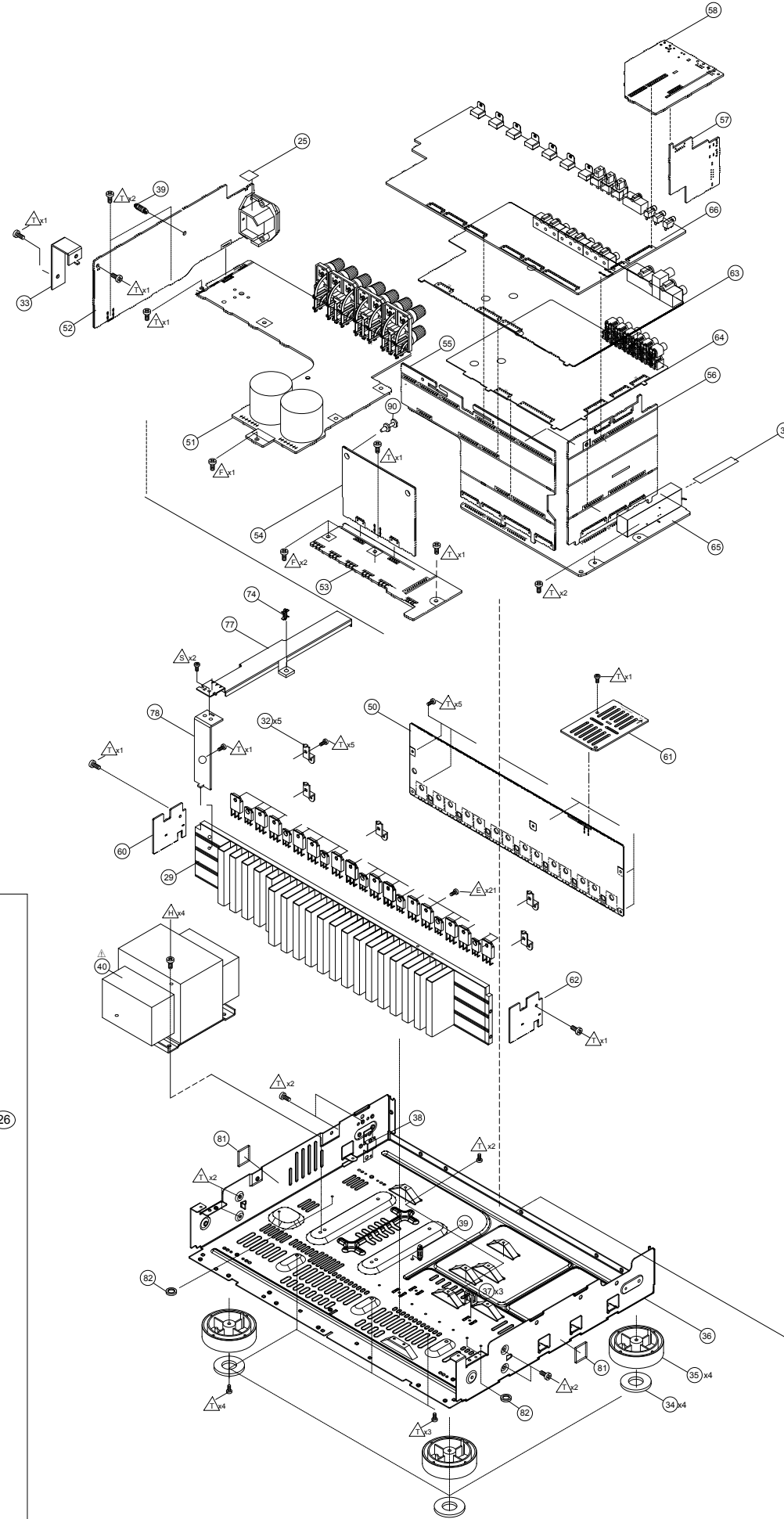
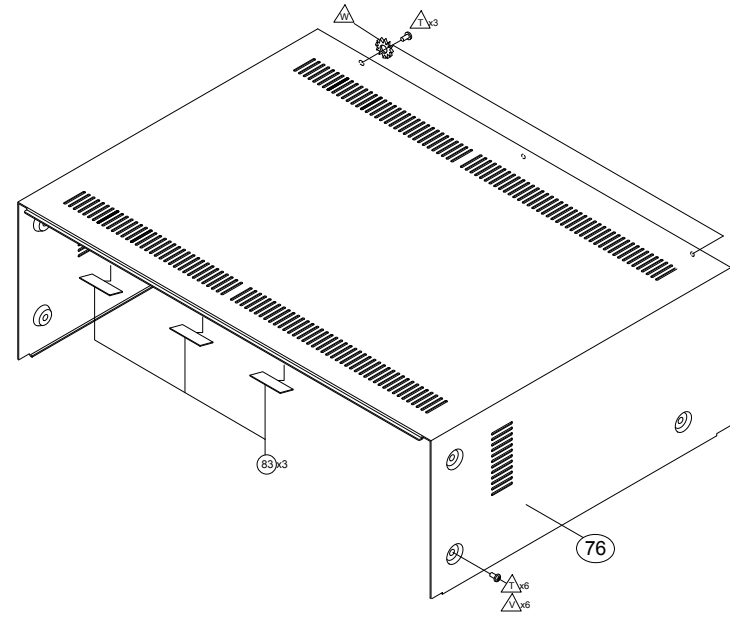

SR6005

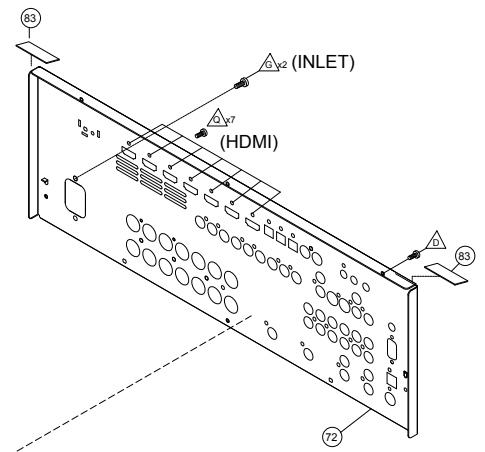

**WARNING:**  
Parts marked with this symbol  have critical characteristics.  
Use ONLY replacement parts recommended by the manufacturer.

# PARTS LIST OF EXPLODED VIEW

\* Parts for which "nsp" is indicated on this table cannot be supplied.

\* P.W.B. ASS'Y for which "nsp" is indicated on this table cannot be supplied. When repairing the P.W.B. ASS'Y, check the board parts table and order replacement parts.

\* Part indicated with the mark "★" is not illustrated in the exploded view.

\* The parts listed below are for maintenance only, might differ from the parts used in the unit in appearances or dimensions.

**Note:** The symbols in the column "Remarks" indicate the following destinations.

U : North America model

N : Europe model

K : China model

B : Black model

SG : Silver gold model

Ref.No.	Part No.	Part Name	Remarks		Q'ty	New
50	nsp	PCB 7CH_AMP ASSY	U1B	7025HK0930010	1	
50	nsp	PCB 7CH_AMP ASSY	K1B	7025HK0930020	1	
50	nsp	PCB 7CH_AMP ASSY	N1B,N1SG	7025HK0930030	1	
51A	nsp	PCB SPK ASSY	U1B	7025HK0930011	1	
51A	nsp	PCB SPK ASSY	K1B	7025HK0930021	1	
51A	nsp	PCB SPK ASSY	N1B,N1SG	7025HK0930031	1	
51	-	PCB SPK		-		
52	-	PCB SMPS		-		
54A	nsp	PCB REG_CNT ASSY	U1B	7025HK0930012	1	
54A	nsp	PCB REG_CNT ASSY	K1B	7025HK0930022	1	
54A	nsp	PCB REG_CNT ASSY	N1B,N1SG	7025HK0930032	1	
53	-	PCB REG		-		
54	-	PCB REG_CNT		-		
55	-	PCB FRONT_CNT		-		
56	-	PCB SIDE_CNT		-		
57	-	PCB RS232		-		
58	-	PCB SIRIUS		-		
26A	nsp	PCB FRONT ASSY	U1B	7025HK0930013	1	
26A	nsp	PCB FRONT ASSY	K1B	7025HK0930023	1	
26A	nsp	PCB FRONT ASSY	N1B,N1SG	7025HK0930033	1	
26	-	PCB FRONT		-		
59-1	-	PCB USB		-		
59-2	-	PCB MIC_H/P		-		
60	-	PCB GUIDE_L		-		
61	-	PCB H/S GUIDE		-		
62	-	PCB GUIDE_R		-		
63	nsp	PCB VIDEO ASSY	U1B	7025HK0930014	1	
63	nsp	PCB VIDEO ASSY	K1B	7025HK0930024	1	
63	nsp	PCB VIDEO ASSY	N1B,N1SG	7025HK0930034	1	
64A	nsp	PCB AUDIO ASSY	U1B	7025HK0930015	1	
64A	nsp	PCB AUDIO ASSY	K1B	7025HK0930025	1	
64A	nsp	PCB AUDIO ASSY	N1B,N1SG	7025HK0930036	1	
64	-	PCB AUDIO		-		
65	-	PCB PREOUT		-		
66	8U6331006700M	PCB HDMI ASSY	U1B	7025HK0930016	1	*
66	-	PCB HDMI ASSY	K1B	7025HK0930026	1	
66	-	PCB HDMI ASSY	N1B,N1SG	7025HK0930036	1	

**NOTE :**

Please change the destination-resistors when changing SR6005U1B (8U6331006700M) to other destination.

Please refer to destination-resistors 116,117,118 page.

(SCHEMATIC DIAGRAMS : 32/36, 33/36, 34/36)

	R4900(32/36)	R4903(32/36)	R5111(33/36)	R5112(33/36)	R5113(33/36)	R5114(33/36)	R5332(34/36)	R5340(34/36)
6005U1B	OPEN	10K	OPEN	33ohm	OPEN	33ohm	10K	OPEN
6005N1B,N1SG	10K	4.7K	33ohm	OPEN	33ohm	33ohm	OPEN	10K
6005K1B	10K	4.7K	OPEN	OPEN	OPEN	OPEN	10K	10K

	Ref.No.	Part No.	Part Name	Remarks		Q'ty	New
	1	963402012440M	PANEL FRONT	U1B	3067214976030S	1	*
	1	963402012420M	PANEL FRONT	N1B,K1B	3067214976040S	1	*
	1	963402012430M	PANEL FRONT	N1SG	3067214976110S	1	*
	2	963421006200M	BADGE(MARANTZ) SILVER/GRAY		5630210678000S	1	
	3	963416012230M	WINDOW DISPLAY		5077213053000S	1	
	4	943415004150M	DOOR FRONT	U1B,N1B,K1B	5047210656000S	1	
	4	943415004160M	DOOR FRONT	N1SG	5047210656100S	1	
	5	943454004170M	DOOR MOLD	U1B,N1B,K1B	5040210641000S	1	
	5	943454004180M	DOOR MOLD	N1SG	5047210641100S	1	
	6	412410005014M	KNOB ASSY VOLUME	U1B,N1B,K1B	5088212398000SZ	2	
	6	943412002020M	KNOB ASSY VOLUME	N1SG	5088212398010SZ	2	
	7	424510002017M	DECORATION RING KNOB	U1B,N1B,K1B	5127210971000S	2	
	7	943424002030M	DECORATION RING KNOB	N1SG	5127210971100S	2	
	8	nsp	PLATE EARTH DOOR		4470211966000S	1	
	9	943402004240M	PANEL SUB	U1B,N1B,K1B	3067214941000S	1	
	9	943402004250M	PANEL SUB	N1SG	3067214941100S	1	
	10	nsp	DAMPER GEAR		3660210043000S	1	
	11	nsp	SHAFT BASE		2400210046000S	2	
	12	963422012240M	SHEET FRONT	U1B,N1B,K1B	1217211272000S	1	
	12	963422012250M	SHEET FRONT	N1SG	1217211272100S	1	
	13	963404012260M	PANEL SIDE L	U1B,N1B,K1B	3067214951000S	1	
	13	963404012270M	PANEL SIDE L	N1SG	3067214951100S	1	
	14	943422003540M	PANEL SIDE R	U1B,N1B,K1B	3067214961000S	1	
	14	943422003570M	PANEL SIDE R	N1SG	3067214961100S	1	
	15	00M10BW355010	LENS POWER		3710211083000S	1	
	16	963411006110M	BUTTON POWER	U1B,N1B,K1B	5090213961000S	1	
	16	963411012000M	BUTTON POWER	N1SG	5097213961100S	1	
	17	nsp	MAGNET BASE		7600210059000S	1	
	18	943411004310M	BUTTON-ASSY ENTER	U1B,N1B,K1B	5098214491000S	1	
	18	943411004300M	BUTTON-ASSY ENTER	N1SG	5098214491100S	1	
	19	943411004290M	BUTTON 10KEY	U1B,N1B,K1B	5090214421000S	1	
	19	943411004280M	BUTTON 10KEY	N1SG	5097214421100S	1	
	20	00M10BW355020	LENS THX		3710211073000S	1	
	21	00M03CW355010	LENS HDMI		3710211063000S	1	
	22	nsp	BRACKET BODY		4010214956000S	1	
	23	nsp	SHEET V-AUX	U1B,N1B,K1B	1217211332000S	1	
	23	nsp	SHEET V-AUX	N1SG	1217211332010S	1	
	24	nsp	CUSHION DOOR		4050213145100S	2	
	25	nsp	INLET TAPE		1220210759000S	1	
	27	nsp	BRACKET BASE		4010214926000S	1	
	28	nsp	WASHER		1530210142010S	1	
	29	nsp	HEAT SINK MAIN		2120211788000S	1	
	30	nsp	TAPE ACETATE CLOTH(15x60)	U1B	1220210059010S	2	
	32	nsp	BRACKET H SINK		4010056906010S	5	
	33	nsp	BRACKET SMPS		4010214886000S	1	
	34	nsp	CUSHION FOOT		4050211175000S	4	
	35	00M46BW057210	FOOT FRONT		4007210321000S	4	
	36	nsp	CHASSIS MAIN		3200213506200S	1	
	37	nsp	SUPPORTER PCB		4070001601010S	3	
	38	nsp	BRACKET SIDE		4010210686000S	1	
	39	nsp	SUPPORTER P.C.		4070210192000S	2	
⚠	40	963101009710S	POWER TRANS MAIN	U1B	8200960660660S	1	
⚠	40	963101009730S	POWER TRANS MAIN	K1B	8200960660680S	1	
⚠	40	963101009720S	POWER TRANS MAIN	N1B,N1SG	8200960660670S	1	
	72	nsp	CHASSIS BACK	U1B	3207213566400S	1	*
	72	nsp	CHASSIS BACK	K1B	3207213566600S	1	*
	72	nsp	CHASSIS BACK	N1B,N1SG	3207213566500S	1	*

Ref.No.	Part No.	Part Name	Remarks	Q'ty	New
73	nsp	PLATE EARTH CHASSIS		4470212006000S	4
74	nsp	SUPPORTER PCB		4070211653000S	1
75	nsp	TAPE ACETATE CLOTH		1220210059050S	1
76	00M07BW257010	TOP COVER	U1B,N1B,K1B	3007211796000S	1
76	943403002040M	TOP COVER	N1SG	3007211796100S	1
77	nsp	BRACKET HDMI		4010214896100S	1
78	nsp	BRACKET HEATSINK MAIN		4010214906000S	1
81	nsp	CUSHION SIDE		4050213095000S	2
82	nsp	CUSHION SCREW		4050213025000S	4
83	nsp	SHEET CABINET		1210210235000S	5
90	nsp	SPACER CARD		4300210062000S	1
★ 91	963606012450S	CABLE FLAT CARD 1.0MM	L=270	N711402712480S	1
★ 92	963606011210S	CABLE FLAT CARD 1.25MM	U1B	N712130824480S	1
★ 93	963219003340S	TR 2SC KTC3964	Q409,Q421,Q433,Q445,Q457,Q469,Q481	J502396400010S	7
★ 94	00D9630235301	TR 2SD2560Y	Q404,Q416,Q428,Q440,Q452,Q464,Q476	J5032560Y0170S	7
★ 95	00D9630235204	TR 2SB1647Y	Q410,Q422,Q434,Q446,Q458,Q470,Q482	J5011647Y0170S	7
★ 96	963183011000S	HD-RADIO MODULE	U1B	E908071010000S	1
★ 97	nsp	CLAMP CABLE		4330040343010S	7
★ 98	nsp	CLAMP WIRE(MTG)		4330000310000S	2
<b>SCREWS</b>					
A	nsp	SCREW (+2S 3*10 B-TYPE ZNW/BH)		B020030101B10S	26
D	nsp	SCREW (+2S 3*10 B-TYPE(DOT) BK/BH)	U1B	B020030103B11S	47
D	nsp	SCREW (+2S 3*10 B-TYPE(DOT) BK/BH)	N1B,N1SG,K1B	B020030103B11S	49
E	nsp	SCREW (2S 3*14 P(Φ6))+S-WASHER ZNY/HH)		B018230141H11S	21
F	nsp	SCREW (+2S 3*17 B-TYPE ZNW/BH)		B020030171B10S	3
G	nsp	SCREW (+2S 4*8 B-TYPE(DOT) BK/BH)		1500040083B10S	2
H	nsp	SCREW (+3S 4*10 P+S-WASHER(ROUND)BK/BH)		B028940101B11S	4
I	nsp	SCREW (+2S 3*8 ZnY WASHER PI12)		1500001456010S	1
M	nsp	SCREW (+2S 3*8 B-TYPE ZNW/WPH)		B020030081W10S	4
N	nsp	SCREW (+2S 2.6*6 B-TYPE ZNW/WPH)		B020026061P10S	1
P	nsp	SCREW (+2S 3*8 PI9.5 B-TYPE ZNW)		1500001206010S	2
Q	nsp	SCREW (+M 3*6 BK/BH)	U1B	B000030063B10S	8
Q	nsp	SCREW (+M 3*6 BK/BH)	N1B,N1SG,K1B	B000030063B10S	7
T	nsp	SCREW (+2S 3*8(ROUND) BK/BH)	U1B,N1B,K1B	B020230083B10S	52
T	nsp	SCREW (+2S 3*8(ROUND) BK/BH)	N1SG	B020230083B10S	46
S	nsp	SCREW(+2S 3*10 B-TYPE BK/FH)		B020030103F10S	2
U	nsp	SCREW (+2S 3*6 B-TYPE BK/BH )		B020030063B10S	1
V	nsp	SCREW (+2S 3*8 B-TYPE NI/BH)	N1SG	B020030084B10S	6
W	nsp	TOOTHED WASHER		1530210126000S	1
★	nsp	SCREW (3X8 S-TYPE BLACK/BH)	for M-Xport	B020930083B10S	1
★	nsp	SCREW +2S 3*6 B-TYPE(DOT) BK/BH)	U1B for HD Radio	B020930063B10S	2

# PACKING VIEW

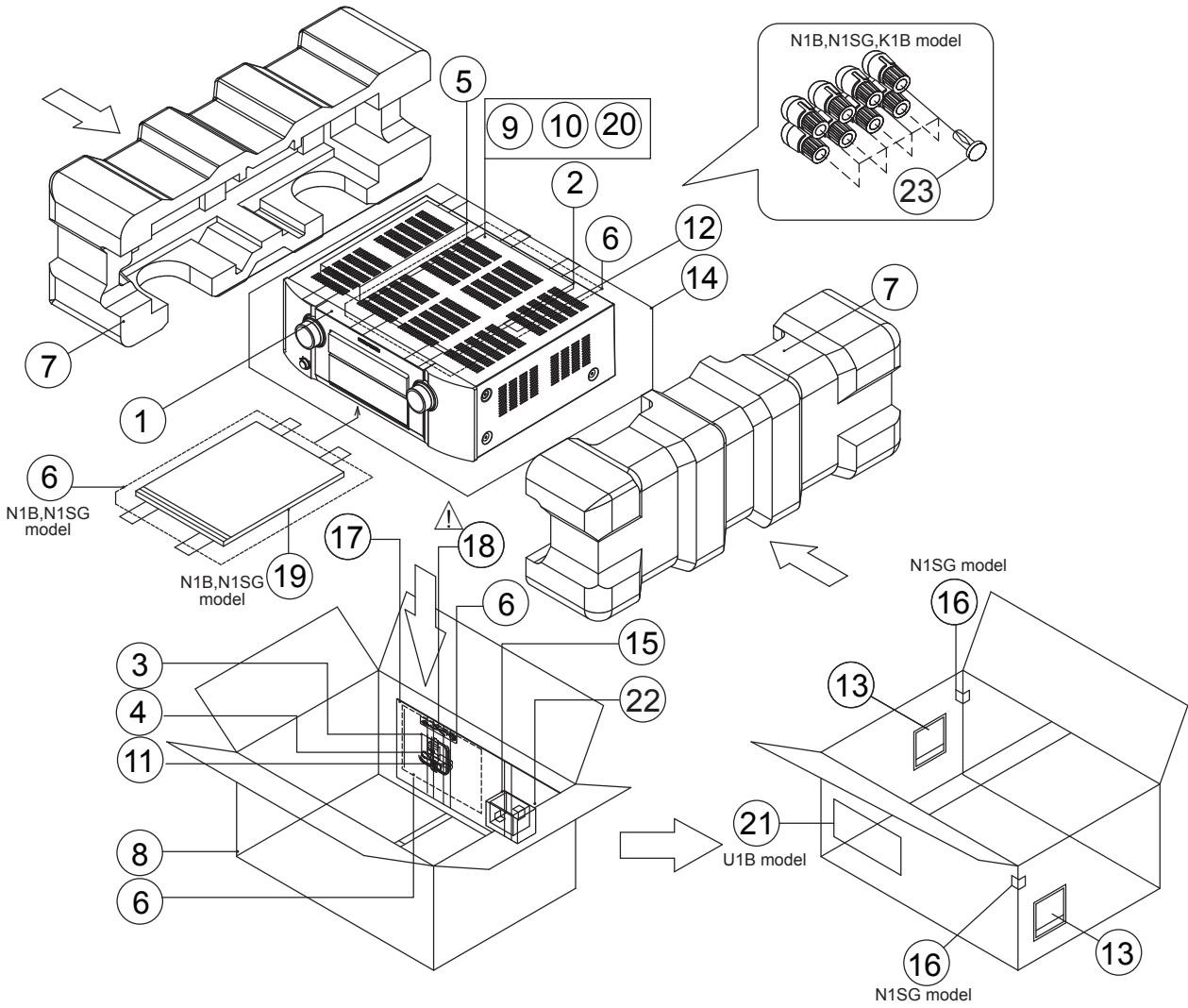

# PARTS LIST OF PACKING & ACCESSORIES

\* Parts for which "nsp" is indicated on this table cannot be supplied.  
 \* Part indicated with the mark "★" is not illustrated in the exploded view.  
 \* The parts listed below are for maintenance only, might differ from the parts used in the unit in appearances or dimensions.

**Note:** The symbols in the column "Remarks" indicate the following destinations.  
 U : North America model      N : Europe model      K : China model  
 B : Black model                SG : Silver gold model

Ref.No.	Part No.	Part Name	Remarks		Q'ty	New
1	-	SET		-		
2	541110482024M	INSTRUCTION MANUAL(U1B)	U1B	5707000004210S	1	*
2	541110482055M	INSTRUCTION MANUAL(K1B)	K1B	5707000004220S	1	*
2	541110482031M	INSTRUCTION MANUAL(N1SG)(N1B)	N1B,N1SG	5707000004230S	1	*
3	963116011270S	ANTENNA LOOP WIRE 105UH	U1B	E601016400010S	1	
3	90M-ZA000260R	ANTENNA LOOP WIRE 9.5UH	N1B,N1SG,K1B	E601016000010S	1	
4	00D9600187308	ANTENNA WIRE (FM)		E605010070001S	1	
5	307010077005M	REMOCON RC-011SR		8300011000010S	1	
6	nsp	POLY BAG	U1B,K1B	6337000240010S	3	
6	nsp	POLY BAG	N1B,N1SG	6337000240010S	4	
7	963533012280M	CUSHION SNOW L/R		6230212894000S	1	
8	531210144003M	BOX GIFT		6007211790010S	1	*
9	nsp	WARRANTY CARD	U1B	5727000000111S	1	

	Ref.No.	Part No.	Part Name	Remarks		Q'ty	New
	10	nsp	WARRANTY CARD (Canada)	U1B	5727041650142S	1	
	11	nsp	BATTERY DRY		G670001R50210S	2	
	12	nsp	LICENSE LABEL	U1B	5507000002940S	1	
	12	nsp	LICENSE LABEL	N1B,N1SG,K1B	5507000004570S	1	
	13	nsp	SHIPPING LABEL		5507000007500S	1	
	14	nsp	PE SHEET		6327040059000S	1	
	15	324810004004M	SETUP MIC		M040000310060S	1	
	16	nsp	LABEL COLOR	N1SG	5507000004600S	2	
	17	nsp	PAD BOX BACK		6240210730000S	1	
⚠	18	90M-ZC000470R	CORD ASSY	U1B	L068125130010S	1	
⚠	18	963611004880S	CORD ASSY	K1B	L068250100050S	1	
⚠	18	90M-ZC000600R	CORD ASSY	N1B,N1SG	L068250160020S	1	
	19	541110604077M	INSTRUCTION MANUAL-2(N1SG)(N1B)	N1B,N1SG	5707000004690S	1	*
	20	nsp	PASS CARD	K1B	5777000000020S	1	
	21	nsp	LABEL SIRIUS HD RADIO	U1B	5507000005290S	1	
	22	nsp	POLY BAG ACCESSORY		6330210222000S	1	
	23	nsp	BUSHING TERMINAL	N1B,N1SG,K1B	2410040353010S	18	

# SEMICONDUCTORS

Only major semiconductors are shown, general semiconductors etc. are omitted to list.  
The semiconductor which described a detailed drawing in a schematic diagram are omitted to list.

## 1. IC's

### R5F64169DFD (HDMI : U5301)

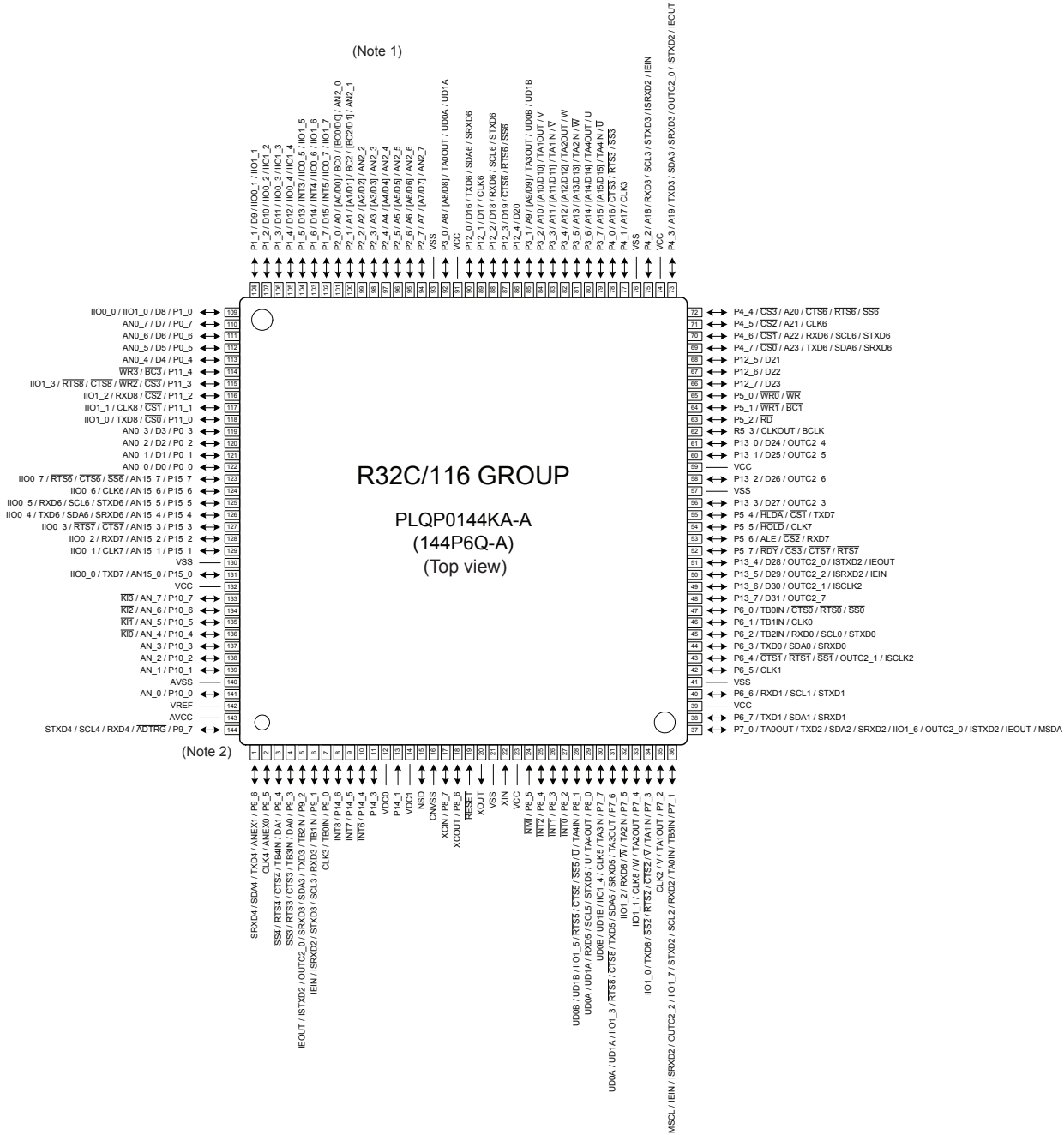

- Notes:
- Pin names in brackets [ ] represent a functional signal as a whole and should not be considered as two separate pins.
  - The position of pin number 1 varies by product. Refer to the index mark in attached "Package Dimensions".



## R5F64169DFD Terminal Functions

Pin	Pin Name	Symbol	I/O	Type	Pullup	Lv Cnv	STBY	stop	Function
1	P96/(TXD4)	SIRIUS RST	O	C	-	3/5	O/L	O/L	NC
2	P95/(CLK4)	HD RADIO RST/ST IND	O/O/I	C/C/-	-	-	O/L	O/L	HD RADIO control pin /ANALOG TUNER control
3	P94/(CTS4)/TB4IN	NC	O/I	C/-	-	-	O/L	O/L	NC
4	P93/(CTS3)/TB3IN	NC	O/I	C/-	-	-	O/L	O/L	NC
5	P92/TXD3/SDA3	HDRADIO MOHI/TU SDA	O/I_O	C	-	-	O/L	O/L	HD RADIO control/ANALOG TUNER control
6	P91/RXD3/SCL3	HDRADIO MIHO/TU SCL	I/O	-/C	-	-	O/L	O/L	HD RADIO control/ANALOG TUNER control
7	P90/(CLK3)	USB POWER	O	C	-	-	O/L	O/L	USB(TELECHIPS) POWER control pin
8	P146/INT8	POWER KEY	I	-	3VPu	-	I	I	POWER KEY (WAIT MODE cancel, interrupt port)
9	P145/INT7	REQ SOMI	I	-	-	-	I	O/L	MAIN-SUB u-com communication control output pin
10	P144/INT6	RDS CLK(SR6005 N model)	I	-	-	3/5	I	I	RDS control(SR6005 N model)(Interrupt detection)
11	P143	CPU POWER	O	C	-	-	O/L	O/L	MAIN CPU POWER control pin (POWER ON: H) (ETHER=ON or CEC ON = STANDBY: H)
12	VDC0	VDC0	-	-	-	-	-	-	Smoothing capacitor connection pin
13	P141 IN ONLY	DOSD MIFO_BUSY	I	-	-	-	I	O/L	D.OSD CPU control pin
14	VDC1	VDC1	-	-	-	-	-	-	Smoothing capacitor connection pin
15	NSD	NSD	-	-	M3VPu	-	-	-	Emulator communication pin
16	CNVss	CNVSS	-	-	Pd	-	-	-	Single-chip / Micro-processor mode switching (Normal single-chip : L, Rewrite boot program start : H input set)
17	P87/(XCIN)	USB RESET	O	C	-	-	O/L	O/L	USB(TELECHIPS) POWER control pin
18	P86/(XCOUT)	232C POWER(REMOTE PWR)	O	C	-	-	O/L	O/L	232C POWER control pin(ON: H)/
19	RESET	RESET	-	-	M3VPu	-	-	-	Reset input (reset: L)
20	XOUT	X2	-	-	-	-	-	-	Clock output
21	VSS	VSS	-	-	-	-	-	-	GND
22	XIN	X1	-	-	-	-	-	-	Clock input
23	VCC	VCC1	-	-	-	-	-	-	+3V
24	P85/(NMI) IN ONLY	iPod DET	I	-	SW3	-	O/L	O/L	MINI JACK connection detection pin for DOCK connection(Connection:H)
25	P84/INT2	PLDAERR	I	-	-	-	O/L	O/L	PLD ERROR detection
26	P83/INT1	B.DOWN	I	-	-	-	I	I	Power failure detect(Power failure:L)
27	P82/INT0	REMOCON	I	-	3Vin/Pd	-	I	I	Remote control signal input
28	P81	D5V POWER	O	C	-	-	O/L	O/L	Digital 5V power control pin
29	P80/RXD5	iPod RXD	I	-	(3Vin)/	5/3	O/L	O/L	iPod communication control pin
30	P77/(CLK5)	EXP & FL DATA	O	C	-	-	O/L	O/L	EXP control pin & FL control pin
31	P76/TXD5	iPod TXD	O	C	-	3/5	O/L	O/L	iPod communication control pin
32	P75/RXD8	NC	I	-	(3Vin)	5/3	O/L	O/L	NC
33	P74/(CLK8)/TA2OUT	NC	O	C	-	-	O/L	O/L	NC
34	P73/TXD8	RDS DATA(SR6005 N model)	O/I	C/N	-	3/5	O/L	O/L	RDS control pin (SR6005 N model)
35	P72/CLK2	DOSD CPU CLK	O	C	-	-	O/L	O/L	D.OSD CPU control pin
36	P71/RXD2	DOSD CPU RX	I	-	-	-	O/L	O/L	D.OSD CPU control pin
37	P70/TXD2	DOSD CPU TX	O	C	-	-	O/L	O/L	D.OSD CPU control pin
38	P67/TXD1	TXD MO232I	O	C	-	-	O/L	O/L	Data transfer to external pin(AMX)/MITSUBISHI writer rewrite
39	VCC	VCC1	-	-	-	-	-	-	+3V
40	P66/RXD1	RXD MI232O	I	-	-	-	I	O/L	Data received from the external pin(AMX) /MITSUBISHI writer rewrite
41	VSS	VSS	-	-	-	-	-	-	GND
42	P65/(CLK1)/SCLK(L)	EXP & FL CLK	O	C	Pd	-	O/L	O/L	EXP control pin & FL control pin
43	P64/(BUSY)	FL CE1	O	C	-	-	O/L	O/L	FL control order pin
44	P63/TXD0	EUSB TXD	O	C	-	-	O/L	O/L	USB(TELECHIPS) control pin
45	P62/RXD0	USB RXD	I	-	-	-	I	O/L	USB(TELECHIPS) control pin
46	P61/(CLK0)	FL RST	O	C	-	-	O/L	O/L	FL control pin
47	P60/(CTS0)	DOSD WRITE	O	C	-	-	O/L	O/L	D. OSD rewrite control pin
48	P137	ACK SIMO	O	C	-	-	O/L	O/L	MAIN-SUB u-com communication control output pin
49	P136/ISCLK2	CLK MO	O	C	-	-	O/L	O/L	MAIN-SUB u-com communication control output pin
50	P135/ISRXD2	SOMI	I	-	-	-	I	O/L	MAIN-SUB u-com communication control output pin
51	P134/ISTXD2	MOSI	O	C	-	-	O/L	O/L	MAIN-SUB u-com communication control output pin
52	P57/RDY	RDY	I	C	M3VPu	-	I	I	External memory access pin(NC,Pup)
53	P56/ALE	ALE	O	C	-	-	O/L	O/L	External memory access pin(NC)
54	P55/HOLD/EPM	HOLD/FRASH EPM	I	C	M3VPu	-	I	I	External memory access pin(NC,Pup) /Rewrite boot program start : L input set
55	P54/HLDA	HLDA	O	C	-	-	O/L	O/L	External memory access pin(NC)
56	P133	ROM POWER	O	C	-	-	O/L	O/L	3.3V control pin for enhancing ROM
57	VSS	VSS	-	-	-	-	-	-	GND
58	P132	D.OSD MOFI_BUSY	O	C	-	-	O/L	O/L	D.OSD CPU control pin

Pin	Pin Name	Symbol	I/O	Type	Pullup	Lv Cnv	STBY	stop	Function
59	VCC	VCC2	-	-	-	-	-	-	+3V
60	P131	RST SUB	O	C	-	-	O/L	O/L	Output for reset of sub-μcom
61	P130	SCPU POWER	O	C	-	-	O/L	O/L	SUB CPU POWER ON/OFF switch(H:ON)
62	P53/BCLK	BCLK	O	C	-	-	O/L	O/L	External memory access pin(NC)
63	P52/RD	RD	O	C	-	-	O/L	O/L	External memory access pin(Connection:OE#)
64	P51/(WR1)/BC1	BC1	O	C	-	-	O/L	O/L	External memory access pin(NC)
65	P50/(WR0)/WR/CE	WR/FRASH CE	O	C	Pd	-	O/L	O/L	External memory access pin(Connection:WE#) /Rewrite boot program start : H input set
66	P127	VSEL A	I	-	SW3VPu	-	I	I	Master Volume rotation detect input (Rotary encoder)
67	P126	VSEL B	I	-	SW3VPu	-	I	I	Master Volume rotation detect input (Rotary encoder)
68	P125	SUB UPDATE	O	C	-	-	O/L	O/L	SUB UPDATE mode control (DPMS/D&M WRITTER). Normal:L. SUB rewriting mode:H(SUB reset)
69	P47/CS0/(A23)	CS0	O	C	-	-	O/L	O/L	External memory access pin(Connection:CS#)
70	P46/(CS1)/A22	A22	O	C	-	-	O/L	O/L	External memory access pin(NC)
71	P45/(CS2)/A21	A21	O	C	-	-	O/L	O/L	External memory access pin(NC)
72	P44/(CS3)/A20	A20	O	C	-	-	O/L	O/L	External memory access pin(Connection:A19)
73	P43/A19	A19	O	C	-	-	O/L	O/L	External memory access pin(Connection:A18)
74	VCC	VCC	-	-	-	-	-	-	+3V
75	P42/A18	A18	O	C	-	-	O/L	O/L	External memory access pin(Connection:A17)
76	VSS	VSS	-	-	-	-	-	-	GND
77	P41/A17	A17	O	C	-	-	O/L	O/L	External memory access pin(Connection:A16)
78	P40/A16	A16	O	C	-	-	O/L	O/L	External memory access pin(Connection:A15)
79	P37/A15	A15	O	C	-	-	O/L	O/L	External memory access pin(Connection:A14)
80	P36/A14	A14	O	C	-	-	O/L	O/L	External memory access pin(Connection:A13)
81	P35/A13	A13	O	C	-	-	O/L	O/L	External memory access pin(Connection:A12)
82	P34/A12	A12	O	C	-	-	O/L	O/L	External memory access pin(Connection:A11)
83	P33/A11	A11	O	C	-	-	O/L	O/L	External memory access pin(Connection:A10)
84	P32/A10	A10	O	C	-	-	O/L	O/L	External memory access pin(Connection:A9)
85	P31/A9	A9	O	C	-	-	O/L	O/L	External memory access pin(Connection:A8)
86	P124	EXP STB	O	C	-	-	O/L	O/L	Expansion EXP control pin
87	P123	EXP OE	O	C	Pd	-	O/L	O/L	Expansion EXP control pin
88	P122/(RXD6)	EEPROM SCL/(I_O EXP)	I/O	C	-	-	O/L	I	EEPROM control pin/(Spare I / O EXP Control)
89	P121/(CLK6)	EEPROM SDA/(I_O EXP)	I/O	C	-	-	O/L	I	EEPROM control pin/(Spare I / O EXP Control)
90	P120/(TXD6)	D.OSD CPU RST	O	C	-	-	O/L	O/L	D.OSD CPU control pin
91	VCC	VCC	-	-	-	-	-	-	+3V
92	P30/A8	A8	O	C	-	-	O/L	O/L	External memory access pin(Connection:A7)
93	VSS	VSS	-	-	-	-	-	-	GND
94	P27/A7	A7	O	C	-	-	O/L	O/L	External memory access pin(Connection:A6)
95	P26/A6	A6	O	C	-	-	O/L	O/L	External memory access pin(Connection:A5)
96	P25/A5	A5	O	C	-	-	O/L	O/L	External memory access pin(Connection:A4)
97	P24/A4	A4	O	C	-	-	O/L	O/L	External memory access pin(Connection:A3)
98	P23/A3	A3	O	C	-	-	O/L	O/L	External memory access pin(Connection:A2)
99	P22/A2	A2	O	C	-	-	O/L	O/L	External memory access pin(Connection:A1)
100	P21/A1	A1	O	C	-	-	O/L	O/L	External memory access pin(Connection:A0)
101	P20/A0	A0	O	C	-	-	O/L	O/L	External memory access pin(NC)
102	P17/D15	D15	I/O	C	-	-	O/L	O/L	External memory access pin(Connection:D15)
103	P16/D14	D14	I/O	C	-	-	O/L	O/L	External memory access pin(Connection:D14)
104	P15/D13	D13	I/O	C	-	-	O/L	O/L	External memory access pin(Connection:D13)
105	P14/D12	D12	I/O	C	-	-	O/L	O/L	External memory access pin(Connection:D12)
106	P13/D11	D11	I/O	C	-	-	O/L	O/L	External memory access pin(Connection:D11)
107	P12/D10	D10	I/O	C	-	-	O/L	O/L	External memory access pin(Connection:D10)
108	P11/D9	D9	I/O	C	-	-	O/L	O/L	External memory access pin(Connection:D9)
109	P10/D8	D8	I/O	C	-	-	O/L	O/L	External memory access pin(Connection:D8)
110	P07/D7	D7	I/O	C	-	-	O/L	O/L	External memory access pin(Connection:D7)
111	P06/D6	D6	I/O	C	-	-	O/L	O/L	External memory access pin(Connection:D6)
112	P05/D5	D5	I/O	C	-	-	O/L	O/L	External memory access pin(Connection:D5)
113	P04/D4	D4	I/O	C	-	-	O/L	O/L	External memory access pin(Connection:D4)
114	P114	ISEL A	I	-	SW3VPu	-	I	I	Input Selector rotation detect input (Rotary encoder)
115	P113	ISEL B	I	-	SW3VPu	-	I	I	Input Selector rotation detect input (Rotary encoder)
116	P112/(RXD8)	ZVOL CLK	O	C	-	-	O/L	O/L	ZONE VOL(NJW1194) control
117	P111	VOL CLK	O	C	-	-	O/L	O/L	FUNCTION/VOLUME control(R2A15220)
118	P110/(TXD8)	VOL DATA	O	C	-	-	O/L	O/L	FUNCTION/VOLUME control(R2A15220)
119	P03/D3	D3	I/O	C	-	-	O/L	O/L	External memory access pin(Connection:D3)
120	P02/D2	D2	I/O	C	-	-	O/L	O/L	External memory access pin(Connection:D2)
121	P01/D1	D1	I/O	C	-	-	O/L	O/L	External memory access pin(Connection:D1)
122	P00/D0	D0	I/O	C	-	-	O/L	O/L	External memory access pin(Connection:D0)

Pin	Pin Name	Synbol	I/O	Type	Pullup	Lv Cnv	STBY	stop	Function
123	P157	ZVOL DATA	O	C	-	-	O/L	O/L	ZONE VOL(NJW1194) control
124	P156	USB RDY	I	-	Pd	-	O/L	O/L	USB(TELECHIPS) control pin
125	P155/(RXD6)	232C CONTROL (SUB LOG MODE)	O	C	-	-	O/L	O/L	SUB LOG MODE : For 232C course switch control
126	P154/(TXD6)	TUNED	I	-	SW3VPu	-	O/L	O/L	ANALOG TUNER control (Except SR6005 U model)
127	P153	USB PDN	O	C	-	-	O/L	O/L	USB(TELECHIPS) control pin
128	P152/(RXD7)	NC	I	-	Pd	-	O/L	O/L	NC
129	P151/(CLK7)	NC	O	C	Pd	-	O/L	O/L	NC
130	VSS	VSS	-	-	-	-	-	-	GND
131	P150/(TXD7)	NC	O	C	Pd	-	O/L	O/L	NC
132	VCC	VCC	-	-	-	-	-	-	+3V
133	P107/(AN7)/(K13)	ZVOL STB	O	C	-	-	O/L	O/L	ZONE VOL(NJW1194) control
134	P106/AN6/K12	KEY3	I	-	M3VPu	-	I	I	Button input 3
135	P105/AN5/K11	KEY2	I	-	M3VPu	-	I	I	Button input 2
136	P104/AN4/K10	KEY1	I	-	M3VPu	-	I	I	Button input 1
137	P103/AN3	ASO/DC/TH_B	I	-	SW3VPu	-	O/L	O/L	ASO PROTECT/DC PROTECT/Temperature detection B input
138	P102/AN2	MIC/H_P/LIMIT/TH_A	I	-	SW3VPu	-	O/L	O/L	MIC detection/Headphone detection/LIMIT decision detection/ Temperature detection B input (A/D detection)
139	P101/AN1	REDLED	O	C	-	-	O/L	O/L	POWER/STANDBY LED control pin(ON : H)
140	AVSS	AVSS	-	-	-	-	-	-	Analog GND
141	P100/AN0	MODE	I	-	M3VPu	-	I	I	Destination switch input
142	VREF	VREF	-	-	-	-	-	-	Standard power input +3V
143	AVCC	AVCC	-	-	-	-	-	-	Analog power +3V
144	P97/(RXD4)	MAIN POWER	O	C	-	-	O/L	O/L	MAIN POWER control pin

# R5F3650KNFB (HDMI : U5500)

(See Note 3)

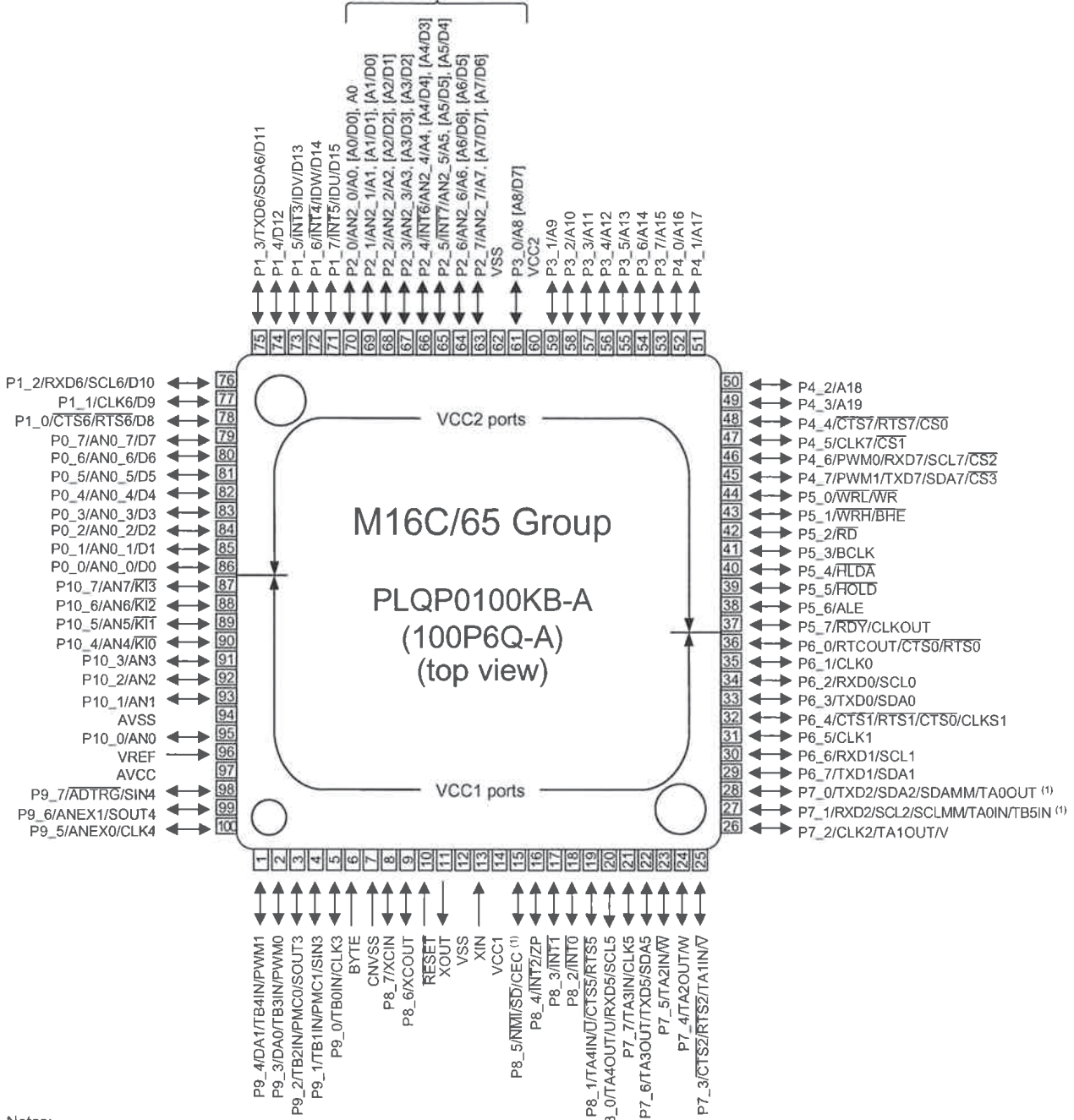

**Notes:**

1. N-channel open drain output.
2. Check the position of Pin 1 by referring to appendix 1, Package Dimensions.
3. Pin names in brackets [ ] represent a single functional signal. They should not be considered as two separate functional signals.

## R5F3650KNFB Terminal Functions

Pin	Pin Name	Symbol	I/O	Type	Det	Op (Int.)	Pu/Pd (Ext.)	Res	PURE D	CEC STBY	P.OFF	Function
1	P94	VSEL DATA	O	C	-	-	-	Z	-	O/L	Z	VIDEO PLD control pin
2	P93	DIR CE	O	C	-	-	-	Z	-	O/L	Z	DIR control pin (LC89058W-VF4A)
3	P92/SOUT3	DIR DIN	O	C	-	-	-	Z	-	O/L	Z	DIR control pin (LC89058W-VF4A)
4	P91/SIN3	DIR DOUT	I	-	Lv	-	DA3.3Pu	Z	-	-	Z	DIR control pin (LC89058W-VF4A)
5	P90/CLK3	DIR CLK	O	C	-	-	-	Z	-	O/L	Z	DIR control pin (LC89058W-VF4A)
6	BYTE	BYTE	-	-	-	-	-	-	-	-	-	GND(Ext. data bus bit width switching, 16bit : L)
7	CNVCS	CNVSS	-	-	-	-	Pd	-	-	-	-	Single-chip/Micro-processor mode switching (Normal single-chip : L, Rewrite boot program start : H input set)
8	P87	ADC RST	O	C	-	-	-	Z	-	O/L	Z	AD(*****) control pin
9	P86	DIR CE4	O	C	-	-	-	Z	-	O/L	Z	DIR control pin (LC89058W-VF4A)
10	RESET	SUBRESET	I	-	Lv	-	SCPU3VPu	L	-	-	Z	Reset input
11	XOUT	X1	O	-	-	-	-	-	-	-	-	Oscillator connection
12	VSS	VSS	-	-	-	-	-	-	-	-	-	GND
13	XIN	X2	I	-	-	-	-	-	-	-	-	Oscillator connection
14	VCC	VCC	-	-	-	-	-	-	-	-	-	+3.3V
15	P85(N)/(NMI)/(CEC)	(CEC_IN)	I	-	-	-	Pd	-	-	-	-	NC ("H" fixed / Reserve (16pin CEC-D signal input for TEST))
16	P84/INT2	CEC_IN	I	-	E <sub>L</sub> &L	-	SCPU3VPu	Z	-	-	Z	CEC-D signal input pin
17	P83/INT1	ACK SIMO	I	-	E <sub>L</sub> &L	-	-	Z	-	-	Z	MAIN-SUB ucom communication control input pin (MAIN ucom Hack from the main "L" Return)
18	P82/INT0	SUB BDOWN	I	-	E <sub>L</sub> &L	-	-	Z	-	-	Z	Power failure detect(Power failure:L)
19	P81	ABT RST	O	C	-	-	-	Z	-	O/H	Z	IP CONV(ABT2015) Reset
20	P80/(RXD5)	NC	I	-	-	-	Pd	Z	-	-	Z	NC
21	P77/(CLK5)	SUB TDO	I	-	-	-	-	Z	-	O/L	Z	PLD rewriting control (JTAG)
22	P76/(TXD5)	A PLD CS "D/M"	O	C	-	-	-	Z	-	-	O/L	A PLD control pin/ D&M WRITTER / MITSUBISHI rewritten for determining (DW :L)
23	P75	A PLD DATA	O	C	-	-	-	Z	-	O/L	Z	A PLD control pin
24	P74	A PLD CLK	O	C	-	-	-	Z	-	O/L	Z	A PLD control pin
25	P73/CTS2	NC	I	-	-	-	Pd	Z	-	-	Z	NC
26	P72/CLK2	DA POWER	O	C	-	-	-	Z	O/H	-	Z	DIGITAL power (DA3.3V,DA1.2V) ON/OFF control (H: ON)
27	P71(N)/RXD2/ SCLMM	HSCL(400k)	I/O	N	-	-	CEC3VPu	Z	-	O/L	O/L	VIDEO I <sup>2</sup> C- IP CONV(ABT2015)/HDMI_R(ADV7840)/ HDMI T(ADV7511)/SWITCHER(ADV3002)
28	P70(N)/TXD2/ SDAMM	HSDA(400k)	I/O	N	-	-	CEC3VPu	Z	-	O/L	O/L	VIDEO I <sup>2</sup> C- IP CONV(ABT1030)/HDMI_R(ADV7840)/ HDMI T(ADV7511)/SWITCHER(ADV3002)
29	P67/TXD1	TXD	O	C	-	-	SCPU3VPu	Z	-	-	Z	Data transmission output to external
30	P66/RXD1	RXD	I	-	Lv	-	SCPU3VPu	Z	-	-	Z	Data reception input from the external
31	P65/CLK1/SCLK	SCLK	I	-	-	-	Pd	Z	-	-	Z	Emulator communication pin
32	P64/CTS1	HIN SELA	O	C	-	-	-	Z	-	O/L	Z	For HDMI 4/5/6/F selection(TC4052)
33	P63/TXD0	SOMI	O	C	-	-	-	Z	-	-	Z	MAIN-SUB ucom communication control pin
34	P62/RXD0	SIMO	I	-	-	-	-	Z	-	-	Z	MAIN-SUB ucom communication control pin
35	P61/CLK0	CLK SIMO	I	-	-	-	-	Z	-	-	Z	MAIN-SUB ucom communication control pin
36	P60/CTS0	REQ SOMI	O	C	-	-	-	Z	-	-	Z	MAIN-SUB ucom communication control pin
37	P57	1TMDS SW RST	O	C	-	-	SCPU3VPu	Z	-	-	Z	HDMI SWITCHER ADV3002 Reset pin
38	P56	DV POWER2	O	C	-	-	-	Z	O/H	-	Z	DIGITAL.VIDEO power control pin (DV1.8V)
39	P55/EPM	EPM	I	-	-	-	Pd	Z	-	-	Z	Rewrite boot program start : L input set
40	P54	CEC_OUT	O	C	-	-	-	Z	-	-	Z	CEC-D signal input pin
41	P53	DV POWER3	O	C	-	-	-	Z	O/H	O/L	Z	DIGITAL.VIDEO power control pin (DV1.0V)
42	P52	Z2SSIG.DET	I	-	Lv	-	SCPU3VPu	Z	-	I	Z	ZONE2 S signal presence detection input (Connected: H)
43	P51	HIN SELB	O	C	-	-	-	Z	-	O/L	Z	For HDMI 4/5/6/F selection(TC4052)
44	P50/CE	MONI SEL/CE/ DSP BOOT	O/I	C	-	-	SCPU3VPu	Z	-	-	Z	MONI SEL(for Dual Moni)(MAX4886) /Rewrite boot program start : H input set
45	P47/(TXD7)/SDA7	VSDA	I/O	C	-	-	DV3VPu	Z	-	-	O/L	ENCODER ADV7392 I <sup>2</sup> C/VIDEO SELECT IC(NJW1327)
46	P46/(RXD7)/SCL7	VSCL	I/O	C	-	-	DV3VPu	Z	-	-	O/L	ENCODER ADV7392 I <sup>2</sup> C/VIDEO SELECT IC(NJW1327)
47	P45/(CLK7)	NC	I	-	-	-	Pd	Z	-	I	Z	NC
48	P44	HPD1	O	C	-	-	-	Z	-	O/L	Z	HP DET control pin
49	P43	HDMI A.SEL	O	C	-	-	-	Z	-	O/L	Z	HDMI AUDIO switch (H : DSP course, L : HDMI Rx→Tx through)(TC74VHC244)
50	P42	NC	I	-	-	-	Pd	Z	-	I	Z	NC
51	P41	CEC POWER	O	C	-	-	-	Z	O/H	O/H	Z	Power ON (CEC5V,CEC3.3V,CEC1.8V) for CEC STANDBY
52	P40	HPD2	O	C	-	-	-	Z	-	O/L	Z	HP DET control pin
53	P37	HDMIR_RST	O	C	-	-	SCPU3VPu	Z	-	-	Z	Reset for HDMI RECEIVER(ADV7840)
54	P36	1TX RST	O	C	-	-	SCPU3VPu	Z	-	-	Z	Reset for HDMI TRANSMITTER (ADV7511)
55	P35	ENC RST	O	C	-	-	SCPU3VPu	Z	-	O/L	Z	Reset for VIDEO ENCODER (ADV7392)
56	P34	Z1 SSGDET	I	-	Lv	-	SCPU3VPu	Z	-	-	Z	S signal presence detection input (Connected: H)
57	P33	HPD3	O	C	-	-	-	Z	-	O/L	Z	HP DET control pin

Pin	Pin Name	Symbol	I/O	Type	Det	Op (Int.)	Pu/Pd (Ext.)	Res	PURE D	CEC STBY	P.OFF	Function
58	P32	DAC MDI	O	C	-	-	-	Z	-	O/L	Z	DAC control pin (ASK4358)
59	P31	DAC MC	O	C	-	-	-	Z	-	O/L	Z	DAC control pin (ASK4358)
60	VCC	VCC	-	-	-	-	-	-	-	-	-	+3.3V
61	P30	DAC MS	O	C	-	-	-	Z	-	O/L	Z	DAC control pin (ASK4358)
62	VSS	VSS	-	-	-	-	-	-	-	-	-	GND
63	P27	DAC RST	O	C	-	-	-	Z	-	O/L	Z	DAC control pin (ASK4358)
64	P26	DV POWER	O	C	-	-	-	Z	O/H	MODE1=0/H MODE2=0/L	Z	DIGITAL VIDEO power control pin (DV5V,DV3.3V)
65	P25/INT7	OSD CPU BUSY SIFO	I	-	Lv	-	Pd	Z	-	-	Z	OSD CPU control pin
66	P24/INT6	1TX INT	I	-	Lv	-	-	Z	-	-	Z	HDMI OUT1 signal presence detection input (HDMI TRANS1 ADV7511)
67	P23	SUB TMS	O	C	-	-	DA3.3Pu	Z	-	-	Z	PLD rewriting control (JTAG)
68	P22	VEXP STB	O	C	-	-	-	Z	-	O/L	Z	Terminal output for VIDEO expander pin (BU4094BCFV)
69	P21	VEXP OE	O	C	-	-	-	Z	-	O/L	Z	Terminal output for VIDEO expander pin (BU4094BCFV)
70	P20	VEXP CLK	O	C	-	-	-	Z	-	O/L	Z	CLK output for VIDEO expander control(BU4094BCFV)
71	P17/INT5	ADVINT1	I	-	E <sub>L</sub> &L	-	-	Z	-	-	Z	HDMI RECEIVER(ADV7840)INT1 output
72	P16/INT4	ADVINT2	I	-	E <sub>L</sub> &L	-	-	Z	-	-	Z	HDMI RECEIVER(ADV7840)INT2 output
73	P15/INT3	ADVINT3	I	-	E <sub>L</sub> &L	-	-	Z	-	-	Z	HDMI RECEIVER(ADV7840)INT3 output
74	P14	HPD4	O	C	-	-	-	Z	-	O/L	Z	HP DET control pin
75	P13/TXD6	DSP MOSI	O	C	-	-	DA3VPu	Z	-	O/L	Z	DSP control pin(ADSP-21367-333)
76	P12/RXD6	DSP MISO	I	-	Lv	-	DA3VPu	Z	-	-	Z	DSP control pin(ADSP-21367-333)
77	P11/CLK6	DSPICLK	O	C	-	-	DA3VPu	Z	-	O/L	Z	DSP control pin(ADSP-21367-333)
78	P10	Z1V/SIG.DET	I	-	Lv	-	SCPU3VPu	Z	-	-	Z	VIDEO IN signal presence detection input(Signal input:H)
79	P07	SUB TDI	O	C	-	-	DA3.3Pu	Z	-	O/L	Z	PLD rewriting control (JTAG)
80	P06	VSEL CS	O	C	-	-	-	Z	-	MODE1=0/H MODE2=0/L	Z	VIDEO PLD control pin
81	P05	NC	I	-	-	-	Pd	Z	-	-	Z	NC
82	P04	NC	I	-	-	-	Pd	Z	-	-	Z	NC
83	P03	SUB TCK	O	C	-	-	Pd	Z	-	-	Z	PLD rewriting control (JTAG)
84	P02	DIR RST3	O	C	-	-	-	Z	-	O/L	O/L	DIR control pin (LC89058W-VF4A)
85	P01	DIR RST2	O	C	-	-	-	Z	-	O/L	O/L	DIR control pin (LC89058W-VF4A)
86	P00	DIR RST1	O	C	-	-	-	Z	-	O/L	O/L	DIR control pin (LC89058W-VF4A)
87	P107/(AN7)	DSP RST	O	C	-	-	-	Z	-	O/L	Z	DSP(ADSP-21367-333) reset output pin(Reset : L)
88	P106/(AN6)	HPD5	O	C	-	-	-	Z	-	O/L	Z	HP DET control pin
89	P105/(AN5)	DSP ROMRST	O	C	-	-	-	Z	-	O/L	Z	Memory reset for DSP (Reset : L)
90	P104/(AN4)	COMPS DET	I	-	Lv	-	SCPU3VPu	Z	-	-	Z	COMPONENT IN signal presence detection input
91	P103/(AN3)	DSP FLAG0	I	-	Lv	-	Pd	Z	-	-	Z	DSP control pin(ADSP-21367-333)
92	P102/(AN2)	DSPICS	O	C	-	-	DA3VPu	Z	-	O/L	Z	DSP control pin(ADSP-21367-333)
93	P101/(AN1)	HPD6	O	C	-	-	-	Z	-	O/L	Z	HP DET control pin
94	AVSS	AVSS	-	-	-	-	-	-	-	-	-	AD GND
95	P100/(AN0)	VSEL CLK	O	C	-	-	-	Z	-	O/L	Z	VIDEO PLD control pin
96	VREF	VREF	-	-	-	-	-	-	-	-	-	AD standard +3.3V
97	AVCC	AVCC	-	-	-	-	-	-	-	-	-	AD +3.3V
98	P97/(SIN4)	Tx EN	O	C	-	-	-	Z	-	-	Z	AD8195 ENABLE pin for Front HDMI control
99	P96/(SOUT4)	OSD CPU BUSY SOFI	O	C	-	-	Pd	Z	-	-	Z	OSD CPU control pin
100	P95/(CLK4)	VEXP DIN	O	C	-	-	-	Z	-	O/L	Z	DATA output for VIDEO expander control (BU4094BCFV)

# ADV3002BSTZ (HDMI : U1002)

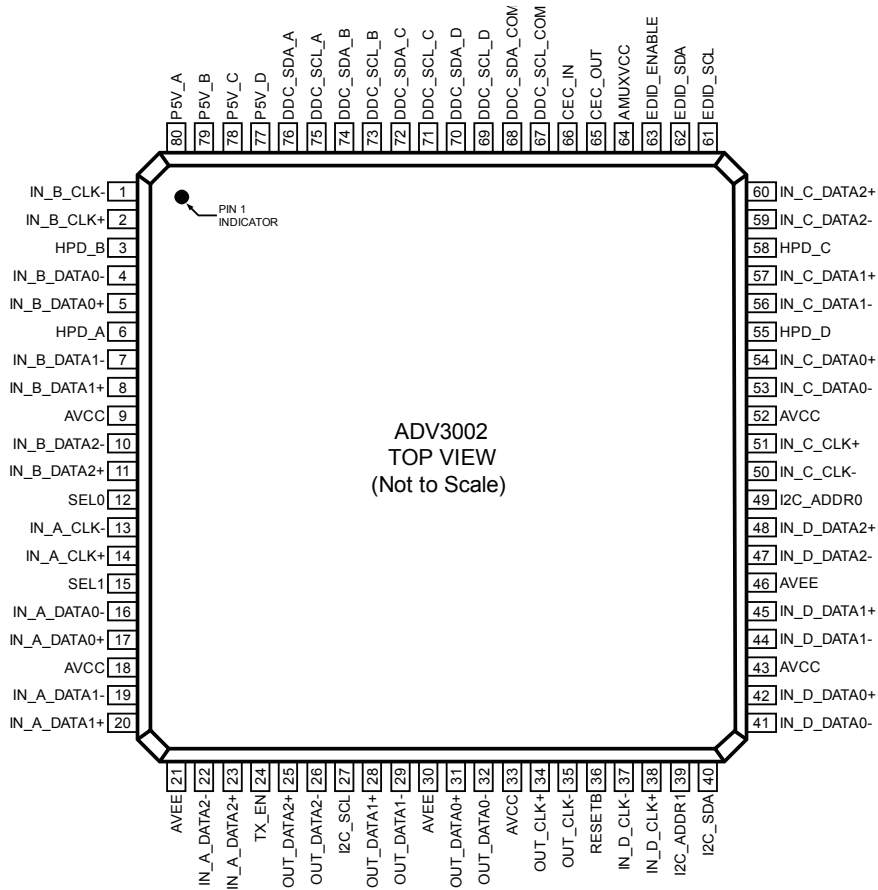

## ADV3002BSTZ Block diagram

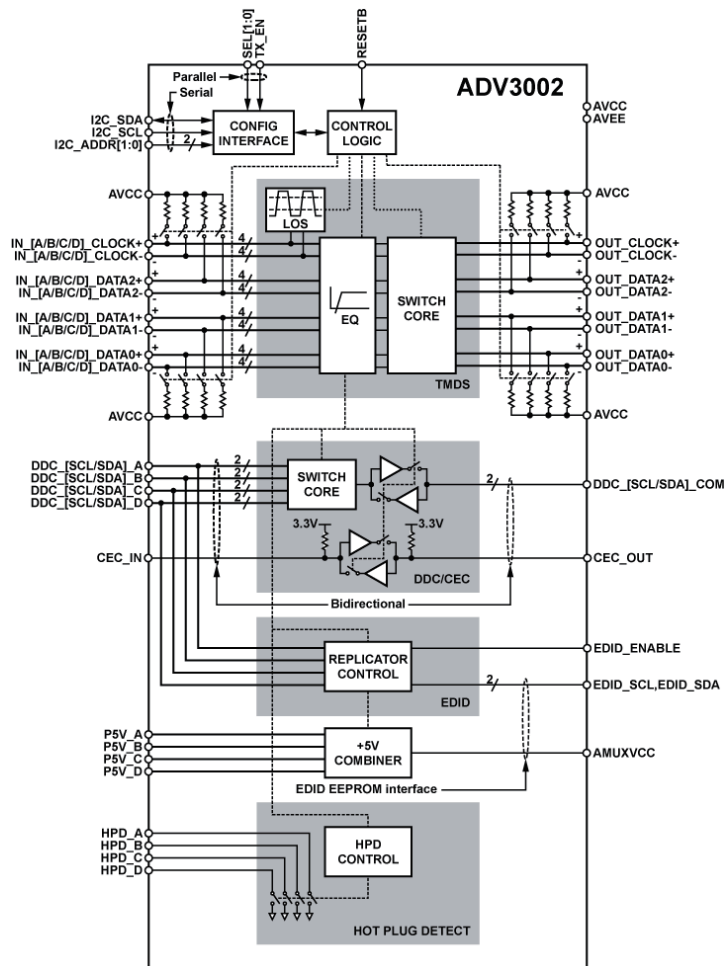

# ADV7511BSTZ (HDMI : U1801)

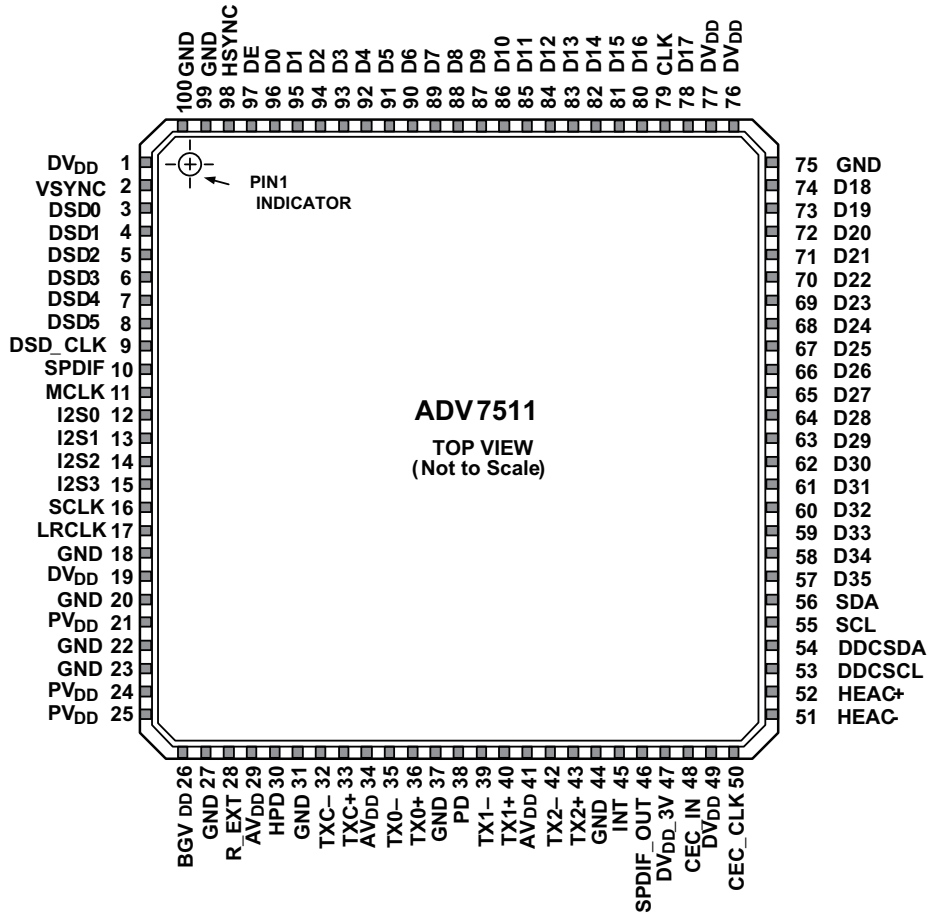

## ADV7511BSTZ Block diagram

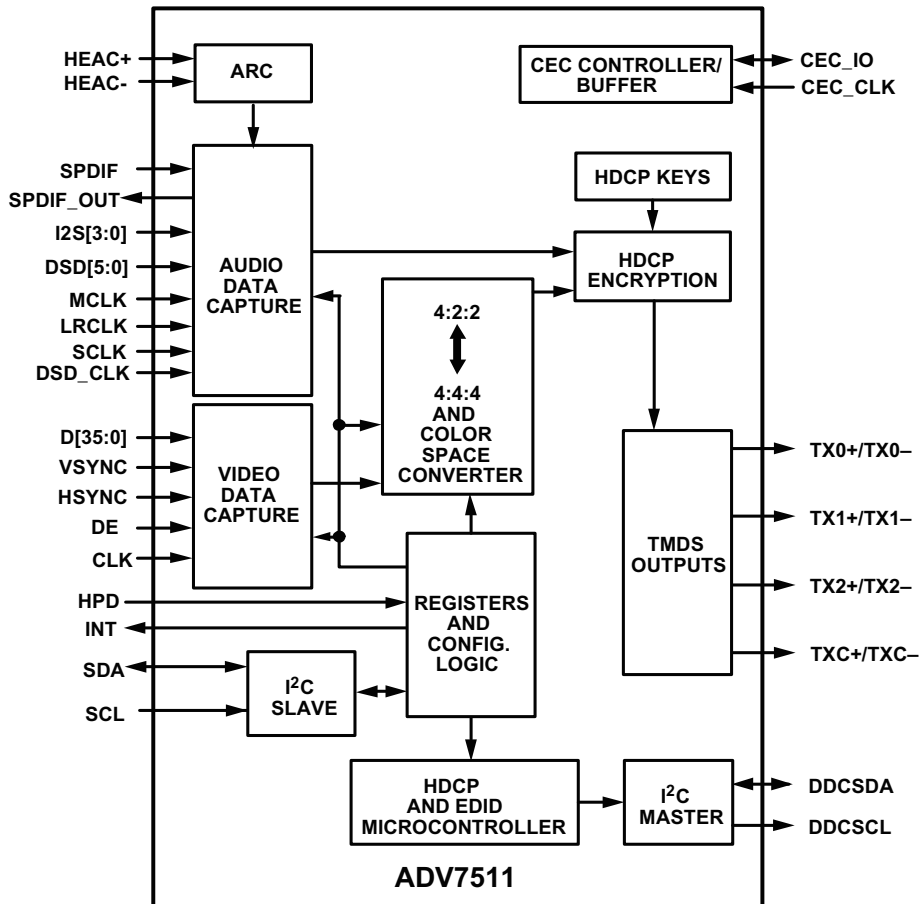



# IS42S32200E6TL (HDMI : U1602)

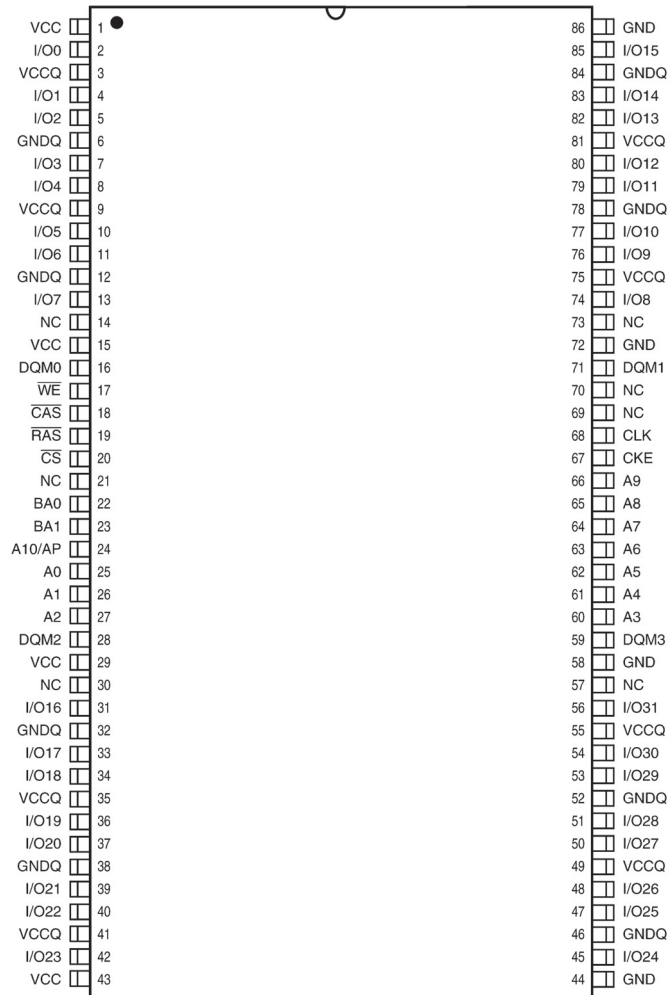

## IS42S32200E6TL Block diagram

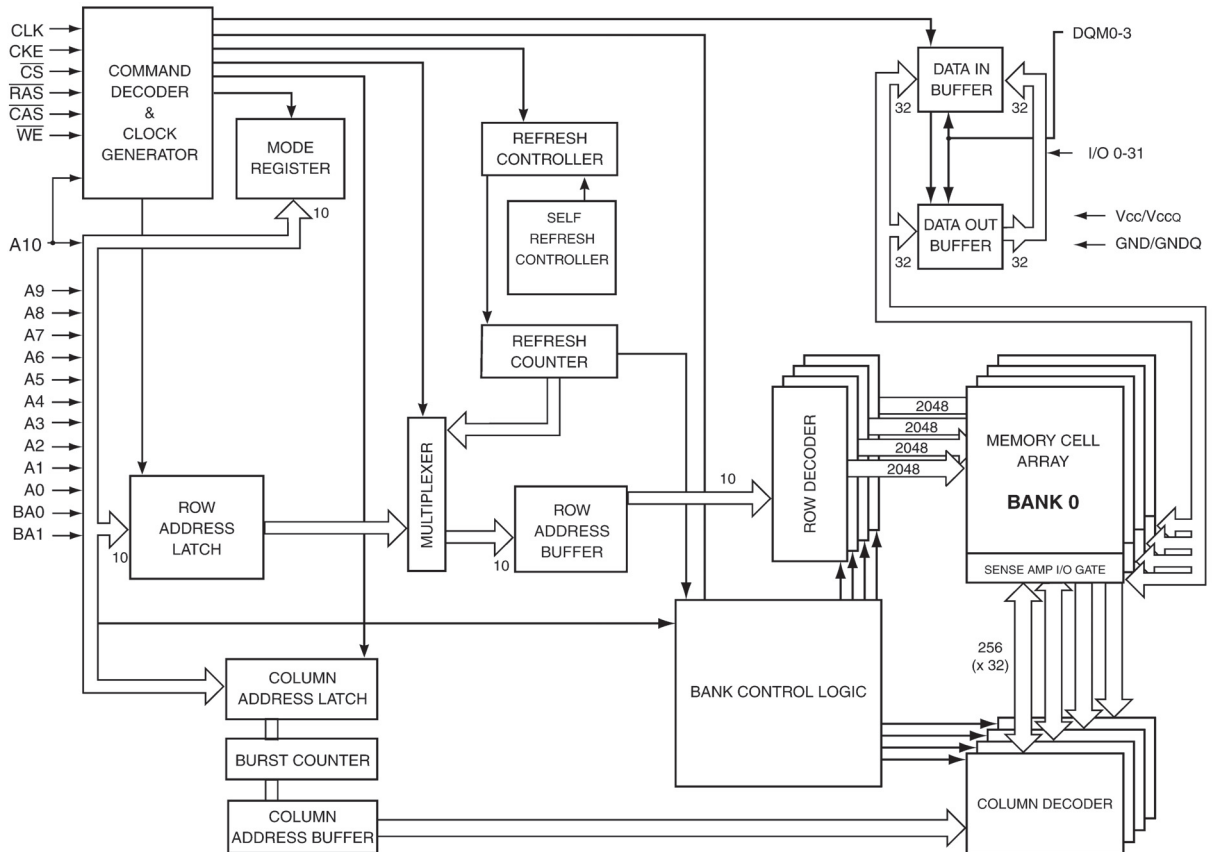

## IS42S32200E6TL Termini Function

Pin No.	Signal	Pin No.	Signal	Pin No.	Signal	Pin No.	Signal
1	VDD	53	VDD	105	VDD	157	VDD
2	DATA28	54	GND	106	GND	158	VDD
3	DATA27	55	IOVDD	107	IOVDD	159	GND
4	GND	56	ADDR0	108	$\overline{\text{SDCAS}}$	160	VDD
5	IOVDD	57	ADDR2	109	$\overline{\text{SDRAS}}$	161	VDD
6	DATA26	58	ADDR1	110	SDCKE	162	VDD
7	DATA25	59	ADDR4	111	$\overline{\text{SDWE}}$	163	TDI
8	DATA24	60	ADDR3	112	$\overline{\text{WR}}$	164	$\overline{\text{TRST}}$
9	DATA23	61	ADDR5	113	SDA10	165	TCK
10	GND	62	GND	114	GND	166	GND
11	VDD	63	VDD	115	IOVDD	167	VDD
12	DATA22	64	GND	116	SDCLK0	168	TMS
13	DATA21	65	IOVDD	117	GND	169	CLK_CFG0
14	DATA20	66	ADDR6	118	VDD	170	BOOTCFG0
15	IOVDD	67	ADDR7	119	$\overline{\text{RD}}$	171	CLK_CFG1
16	GND	68	ADDR8	120	ACK	172	$\overline{\text{EMU}}$
17	DATA19	69	ADDR9	121	FLAG3	173	BOOTCFG1
18	DATA18	70	ADDR10	122	FLAG2	174	TDO
19	VDD	71	GND	123	FLAG1	175	DAI4
20	GND	72	VDD	124	FLAG0	176	DAI2
21	DATA17	73	GND	125	DAI20	177	DAI3
22	VDD	74	IOVDD	126	GND	178	DAI1
23	GND	75	ADDR11	127	VDD	179	IOVDD
24	VDD	76	ADDR12	128	GND	180	GND
25	GND	77	ADDR13	129	IOVDD	181	VDD
26	DATA16	78	GND	130	DAI19	182	GND
27	DATA15	79	VDD	131	DAI18	183	DPI14
28	DATA14	80	AVSS	132	DAI17	184	DPI13
29	DATA13	81	AVDD	133	DAI16	185	DPI12
30	DATA12	82	GND	134	DAI15	186	DPI11
31	IOVDD	83	CLKIN	135	DAI14	187	DPI10
32	GND	84	XTAL2	136	DAI13	188	DPI9
33	VDD	85	IOVDD	137	DAI12	189	DPI8
34	GND	86	GND	138	VDD	190	DPI7
35	DATA11	87	VDD	139	IOVDD	191	IOVDD
36	DATA10	88	ADDR14	140	GND	192	GND
37	DATA9	89	GND	141	VDD	193	VDD
38	DATA8	90	IOVDD	142	GND	194	GND
39	DATA7	91	ADDR15	143	DAI11	195	DPI6
40	DATA6	92	ADDR16	144	DAI10	196	DPI5
41	IOVDD	93	ADDR17	145	DAI8	197	DPI4
42	GND	94	ADDR18	146	DAI9	198	DPI3
43	VDD	95	GND	147	DAI6	199	DPI1
44	DATA4	96	IOVDD	148	DAI7	200	DPI2
45	DATA5	97	ADDR19	149	DAI5	201	CLKOUT
46	DATA2	98	ADDR20	150	IOVDD	202	$\overline{\text{RESET}}$
47	DATA3	99	ADDR21	151	GND	203	IOVDD
48	DATA0	100	ADDR23	152	VDD	204	GND
49	DATA1	101	ADDR22	153	GND	205	DATA30
50	IOVDD	102	$\overline{\text{MS1}}$	154	VDD	206	DATA31
51	GND	103	$\overline{\text{MS0}}$	155	GND	207	DATA29
52	VDD	104	VDD	156	VDD	208	VDD

# LC89058W-E (HDMI : U2805)

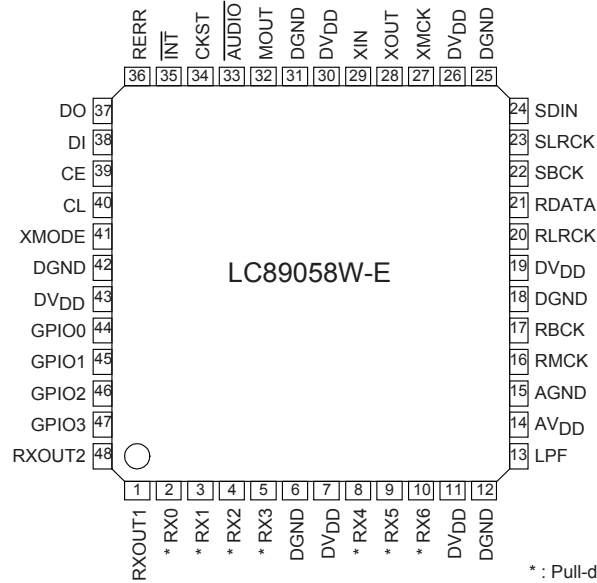

\* : Pull-down resistor internal at no selection

## Pin Functions

Pin No.	Name	I/O	Function
1	RXOUT1	O	RX0-6 input S/PDIF through output pin 1
2	RX0	I <sub>s</sub> (pd)	5V withstand voltage TTL input level compatible S/PDIF input pin (connected to GND when RX1 is set)
3	RX1	I(pd)	Co-axial compatible S/PDIF input pin (supported demodulation sampling frequency of up to 96kHz)
4	RX2	I <sub>s</sub> (pd)	5V withstand voltage TTL input level compatible S/PDIF input pin (connected to GND when RX1 is set)
5	RX3	I <sub>s</sub> (pd)	5V withstand voltage TTL input level compatible S/PDIF input pin
6	DGND		Digital GND
7	DVDD		Digital power supply (3.3V)
8	RX4	I <sub>s</sub> (pd)	5V tolerable TTL input level compatible S/PDIF input pin
9	RX5	I <sub>s</sub> (pd)	5V tolerable TTL input level compatible S/PDIF input pin
10	RX6	I <sub>s</sub> (pd)	5V tolerable TTL input level compatible S/PDIF input pin
11	DVDD		Digital power supply (3.3V)
12	DGND		Digital GND
13	LPF	O	PLL loop filter connection pin
14	AVDD		Analog power supply (3.3V)
15	AGND		Analog GND
16	RMCK	O	R system clock output pin (VCO, 512fs, XIN)
17	RBCK	O/I	R system bit clock I/O pin (64fs)
18	DGND		Digital GND
19	DVDD		Digital power supply (3.3V)
20	RLRCK	O/I	R system LR clock I/O pin (fs)
21	RDATA	O	Serial audio data output pin
22	SBCK	O	S system bit clock output pin (16fs, 32fs, 64fs, 128fs)
23	SLRCK	O	S system LR clock output pin (fs/4, fs/2, fs, 2fs)
24	SDIN	I <sub>s</sub>	External serial audio data input pin

Pin No.	Name	I/O	Function
25	DGND		Digital GND
26	DV <sub>DD</sub>		Digital power supply (3.3V)
27	XMCK	O	Oscillation amplifier clock output pin
28	XOUT	O	Output pin connected to the resonator
29	XIN	I	External clock input pin, connected to the resonator (12.288MHz/24.576MHz)
30	DV <sub>DD</sub>		Digital power supply
31	DGND		Digital GND
32	MOUT	I/O	Emphasis information    Input fs monitor output    Chip address setting input pin
33	AUDIO	I/O	Channel status bit 1 output    Chip address setting input pin
34	CKST	I/O	Clock switching transition period signal output    Master/slave setting input pin
35	INT	I/O	Microcontroller interrupt signal output    Pins44-48 I/O setting input pin
36	RERR	O	PLL lock error, data error flag output pin
37	DO	O	CCB microcontroller I/F, read data output pin (3-state)
38	DI	I <sub>S</sub>	CCB microcontroller I/F, write data input pin
39	CE	I <sub>S</sub>	CCB microcontroller I/F, chip enable input pin
40	CL	I <sub>S</sub>	CCB microcontroller I/F, clock input pin
41	XMODE	I <sub>S</sub>	System reset input pin
42	DGND		Digital GND
43	DV <sub>DD</sub>		Digital power supply (3.3V)
44	GPIO0	O/I	General-purpose I/O pin    Selector input pin (output referred to RDATA pin)
45	GPIO1	O/I	General-purpose I/O pin    Selector input pin (output referred to RLRCK pin)
46	GPIO2	O/I	General-purpose I/O pin    Selector input pin (output referred to RBCK pin)
47	GPIO3	O/I	General-purpose I/O pin    Selector input pin (output referred to RMCK pin)
48	RXOUT2	O	RX0-6 input S/PDIF through output pin 2

\* Input voltage: I = -0.3 to 3.6V, I<sub>S</sub> = -0.3 to 5.5V

\* Output voltage: O = -0.3 to 3.6V

\* Pins 2, 4, 5, 8, 9, 10, 24, 38, 39, 40, and 41 have an internal pull-down resistor (pd).

Their level is fixed when they are unselected.

\* Pins 32 and 33 are input pins for chip address setting when pin 41 is held at the low level.

\* Pin 34 serves as the input pin for designating as the master or slave when pin 41 is held at the low level.

\* Pin 35 serves as the input pin for configuring the I/O of pins 44 to 47 when pin 41 is held at the low level.

\* The DV<sub>DD</sub> and AV<sub>DD</sub> pins must be held at the same level and turned on and off at the same timing to preclude Latch-up conditions.

## LC89058W-E Block diagram

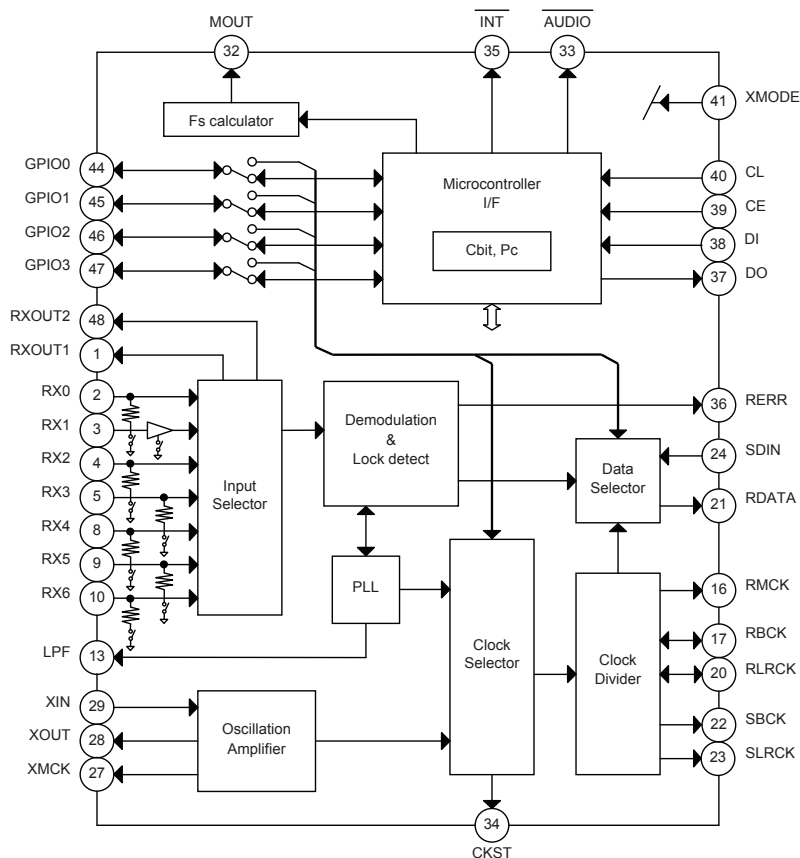

# ADSP21367KSWZ2A (HDMI : U3200)

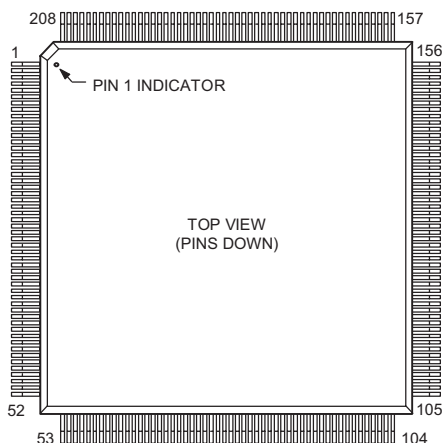

## ADSP21367KSWZ2A Terminal Function

Pin No.	Signal	Pin No.	Signal	Pin No.	Signal	Pin No.	Signal
1	VDD	53	VDD	105	VDD	157	VDD
2	DATA28	54	GND	106	GND	158	VDD
3	DATA27	55	IOVDD	107	IOVDD	159	GND
4	GND	56	ADDR0	108	$\overline{SDCAS}$	160	VDD
5	IOVDD	57	ADDR2	109	$\overline{SDRAS}$	161	VDD
6	DATA26	58	ADDR1	110	SDCKE	162	VDD
7	DATA25	59	ADDR4	111	$\overline{SDWE}$	163	TDI
8	DATA24	60	ADDR3	112	$\overline{WR}$	164	$\overline{TRST}$
9	DATA23	61	ADDR5	113	SDA10	165	TCK
10	GND	62	GND	114	GND	166	GND
11	VDD	63	VDD	115	IOVDD	167	VDD
12	DATA22	64	GND	116	SDCLK0	168	TMS
13	DATA21	65	IOVDD	117	GND	169	CLK_CFG0
14	DATA20	66	ADDR6	118	VDD	170	BOOTCFG0
15	IOVDD	67	ADDR7	119	$\overline{RD}$	171	CLK_CFG1
16	GND	68	ADDR8	120	ACK	172	$\overline{EMU}$
17	DATA19	69	ADDR9	121	FLAG3	173	BOOTCFG1
18	DATA18	70	ADDR10	122	FLAG2	174	TDO
19	VDD	71	GND	123	FLAG1	175	DAI4
20	GND	72	VDD	124	FLAG0	176	DAI2
21	DATA17	73	GND	125	DAI20	177	DAI3
22	VDD	74	IOVDD	126	GND	178	DAI1
23	GND	75	ADDR11	127	VDD	179	IOVDD
24	VDD	76	ADDR12	128	GND	180	GND
25	GND	77	ADDR13	129	IOVDD	181	VDD
26	DATA16	78	GND	130	DAI19	182	GND
27	DATA15	79	VDD	131	DAI18	183	DPI14
28	DATA14	80	AVSS	132	DAI17	184	DPI13
29	DATA13	81	AVDD	133	DAI16	185	DPI12
30	DATA12	82	GND	134	DAI15	186	DPI11
31	IOVDD	83	CLKIN	135	DAI14	187	DPI10
32	GND	84	XTAL2	136	DAI13	188	DPI9
33	VDD	85	IOVDD	137	DAI12	189	DPI8
34	GND	86	GND	138	VDD	190	DPI7
35	DATA11	87	VDD	139	IOVDD	191	IOVDD
36	DATA10	88	ADDR14	140	GND	192	GND
37	DATA9	89	GND	141	VDD	193	VDD
38	DATA8	90	IOVDD	142	GND	194	GND
39	DATA7	91	ADDR15	143	DAI11	195	DPI6
40	DATA6	92	ADDR16	144	DAI10	196	DPI5
41	IOVDD	93	ADDR17	145	DAI8	197	DPI4
42	GND	94	ADDR18	146	DAI9	198	DPI3
43	VDD	95	GND	147	DAI6	199	DPI1
44	DATA4	96	IOVDD	148	DAI7	200	DPI2
45	DATA5	97	ADDR19	149	DAI5	201	CLKOUT
46	DATA2	98	ADDR20	150	IOVDD	202	$\overline{RESET}$
47	DATA3	99	ADDR21	151	GND	203	IOVDD
48	DATA0	100	ADDR23	152	VDD	204	GND
49	DATA1	101	ADDR22	153	GND	205	DATA30
50	IOVDD	102	$\overline{MST}$	154	VDD	206	DATA31
51	GND	103	$\overline{MS0}$	155	GND	207	DATA29
52	VDD	104	VDD	156	VDD	208	VDD

W9864G2IH-6 (HDMI : U3201)

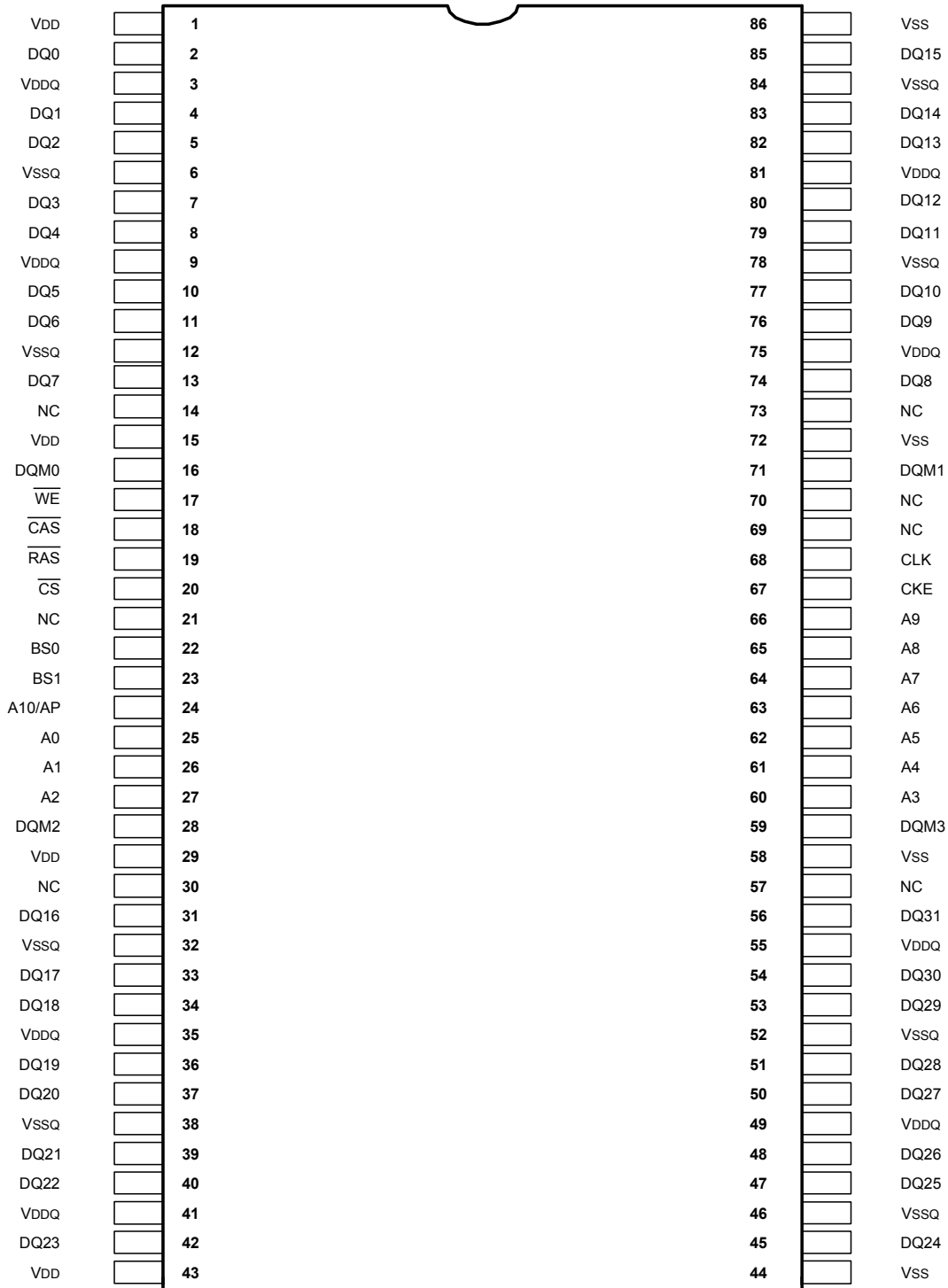

# W9864G2IH-6 Block diagram

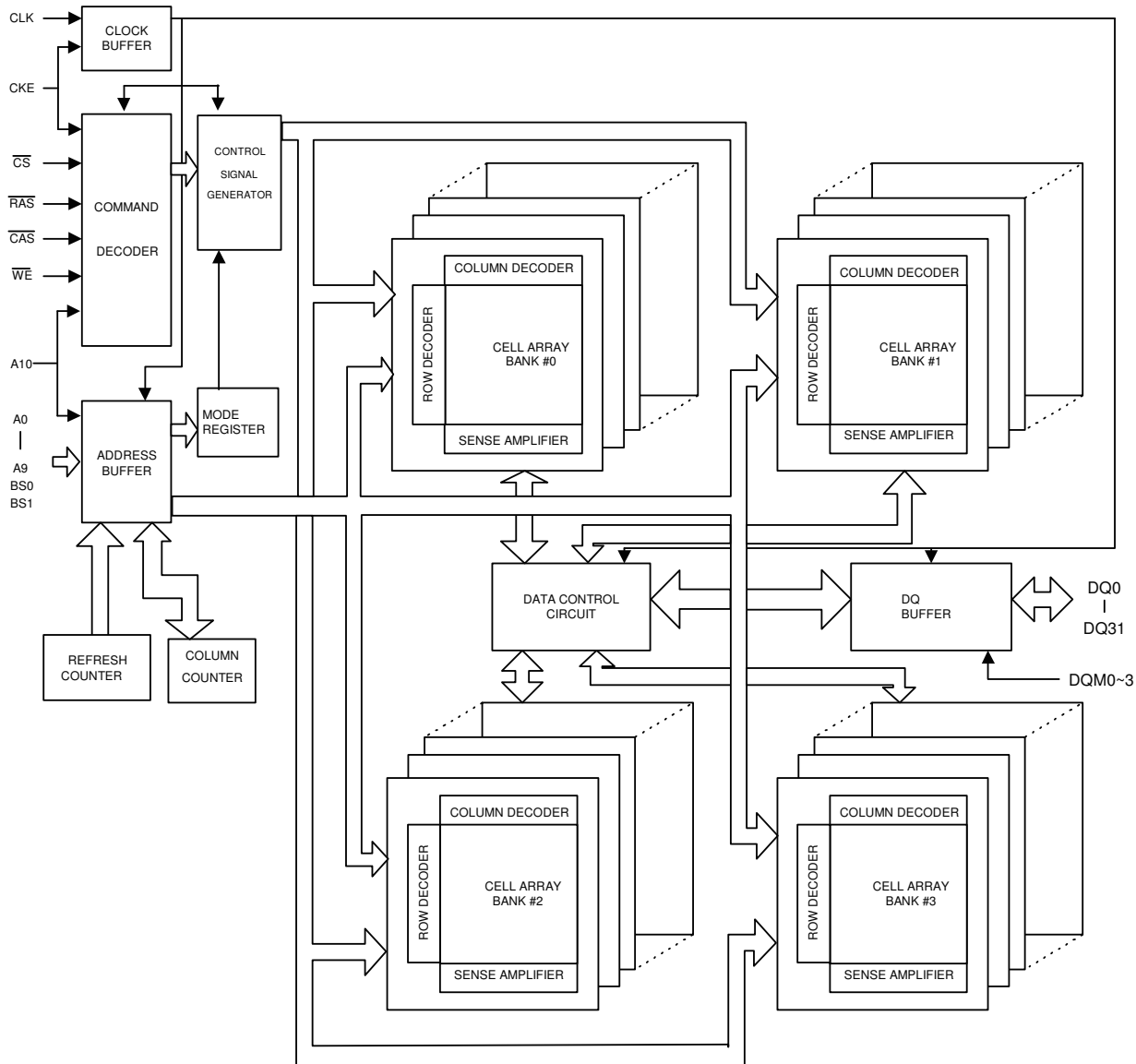

## W9864G2IH-6 Pin description

PIN NUMBER	PIN NAME	FUNCTION	DESCRIPTION
24, 25, 26, 27, 60, 61, 62, 63, 64, 65, 66	A0–A10	Address	Multiplexed pins for row and column address. Row address: A0–A10. Column address: A0–A7. A10 is sampled during a precharge command to determine if all banks are to be precharged or bank selected by BS0, BS1.
22, 23	BS0, BS1	Bank Select	Select bank to activate during row address latch time, or bank to read/write during address latch time.
2, 4, 5, 7, 8, 10, 11, 13, 31, 33, 34, 36, 37, 39, 40, 42, 45, 47, 48, 50, 51, 53, 54, 56, 74, 76, 77, 79, 80, 82, 83, 85	DQ0–DQ31	Data Input/ Output	Multiplexed pins for data output and input.
20	$\overline{CS}$	Chip Select	Disable or enable the command decoder. When command decoder is disabled, new command is ignored and previous operation continues.
19	$\overline{RAS}$	Row Address Strobe	Command input. When sampled at the rising edge of the clock $\overline{RAS}$ , $\overline{CAS}$ and $\overline{WE}$ define the operation to be executed.
18	$\overline{CAS}$	Column Address Strobe	Referred to $\overline{RAS}$
17	$\overline{WE}$	Write Enable	Referred to $\overline{RAS}$
16, 28, 59, 71	DQM0–DQM3	Input/Output Mask	The output buffer is placed at Hi-Z (with latency of 2) when DQM is sampled high in read cycle. In write cycle, sampling DQM high will block the write operation with zero latency.
68	CLK	Clock Inputs	System clock used to sample inputs on the rising edge of clock.
67	CKE	Clock Enable	CKE controls the clock activation and deactivation. When CKE is low, Power Down mode, Suspend mode, or Self Refresh mode is entered.
1, 15, 29, 43	VDD	Power	Power for input buffers and logic circuit inside DRAM.
44, 58, 72, 86	VSS	Ground	Ground for input buffers and logic circuit inside DRAM.
3, 9, 35, 41, 49, 55, 75, 81	VDDQ	Power for I/O Buffer	Separated power from VDD, to improve DQ noise immunity.
6, 12, 32, 38, 46, 52, 78, 84	VSSQ	Ground for I/O Buffer	Separated ground from VSS, to improve DQ noise immunity.
14, 21, 30, 57, 69, 70, 73	NC	No Connection	No connection.



EN29LV160BB (HDMI : U3202, U5101) : Bottom boot Sector  
 EN29LV160BT (HDMI : U4400) : Top boot Sector

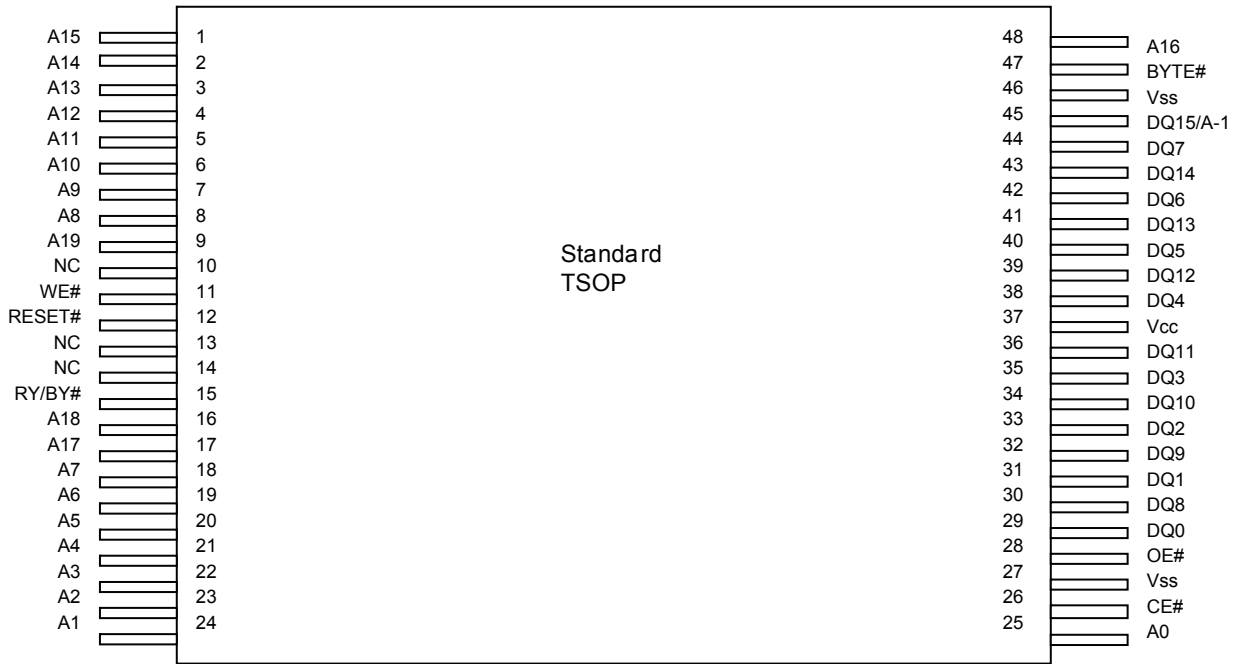

EN29LV160BB/EN29LV160BT Block Diagram

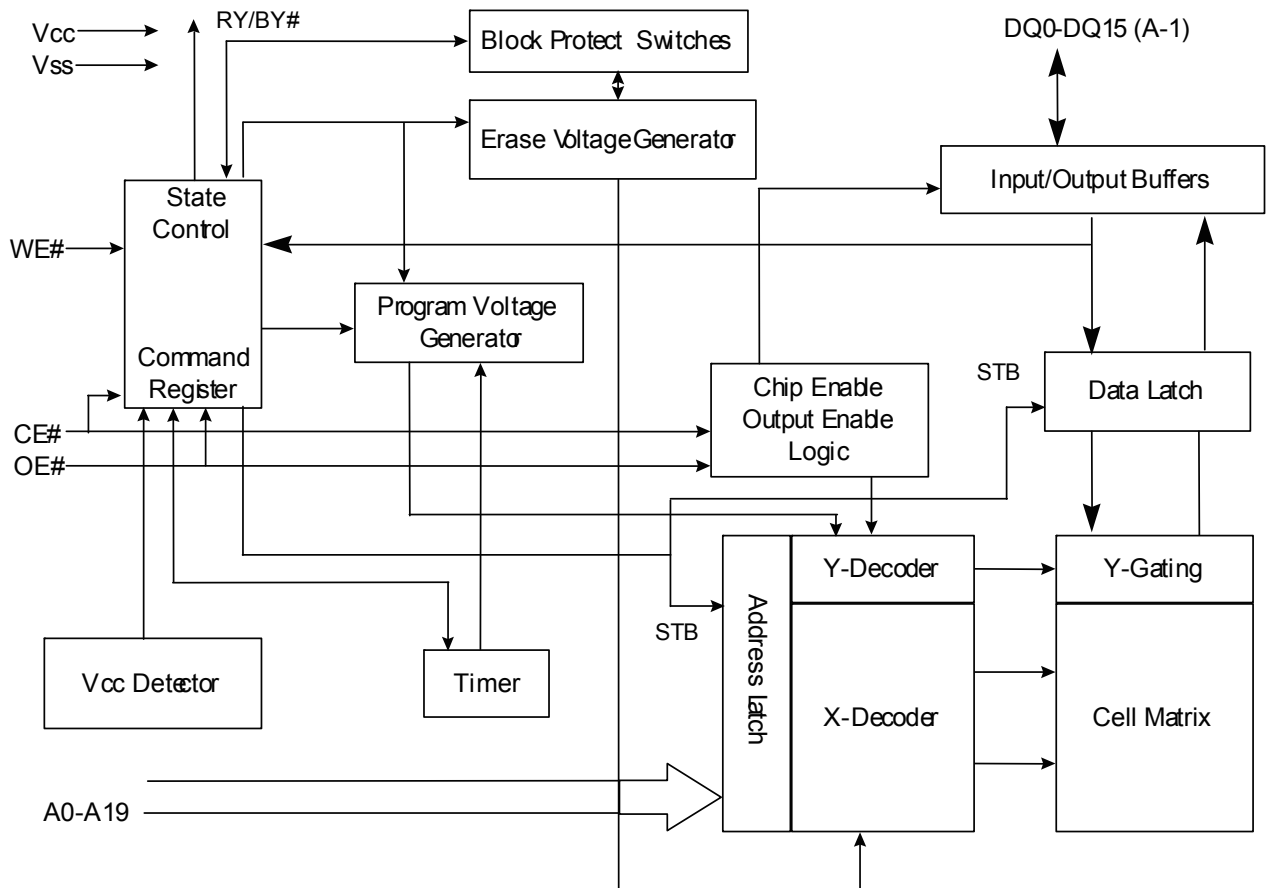

## AK5358BET (HDMI : U3802)

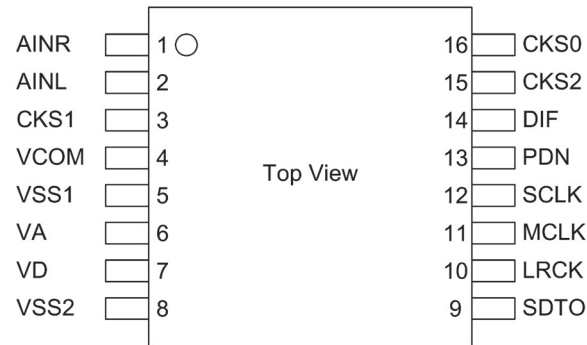

### AK5358BET Pin Function

No.	Pin Name	I/O	Function
1	AINR	I	Rch Analog Input Pin
2	AINL	I	Lch Analog Input Pin
3	CKS1	I	Mode Select 1 Pin
4	VCOM	O	Common Voltage Output Pin, VA/2 Bias voltage of ADC input.
5	VSS1	-	Ground Pin
6	VA	-	Analog Power Supply Pin, 4.5 ~ 5.5V
7	VD	-	Digital Power Supply Pin, 2.7 ~ 5.5V
8	VSS2	-	Ground Pin
9	SDTO	O	Audio Serial Data Output Pin “L” Output at Power-down mode.
10	LRCK	I/O	Output Channel Clock Pin “L” Output in Master Mode at Power-down mode.
11	MCLK	I	Master Clock Input Pin
12	SCLK	I/O	Audio Serial Data Clock Pin “L” Output in Master Mode at Power-down mode.
13	PDN	I	Power Down Mode & Reset Pin “H”: Power up, “L”: Power down & Reset
14	DIF	I	Audio Interface Format Pin “H”: 24bit I <sup>2</sup> S Compatible, “L”: 24bit MSB justified
15	CKS2	I	Mode Select 2 Pin
16	CKS0	I	Mode Select 0 Pin

## AK4358VQ (HDMI : U3803)

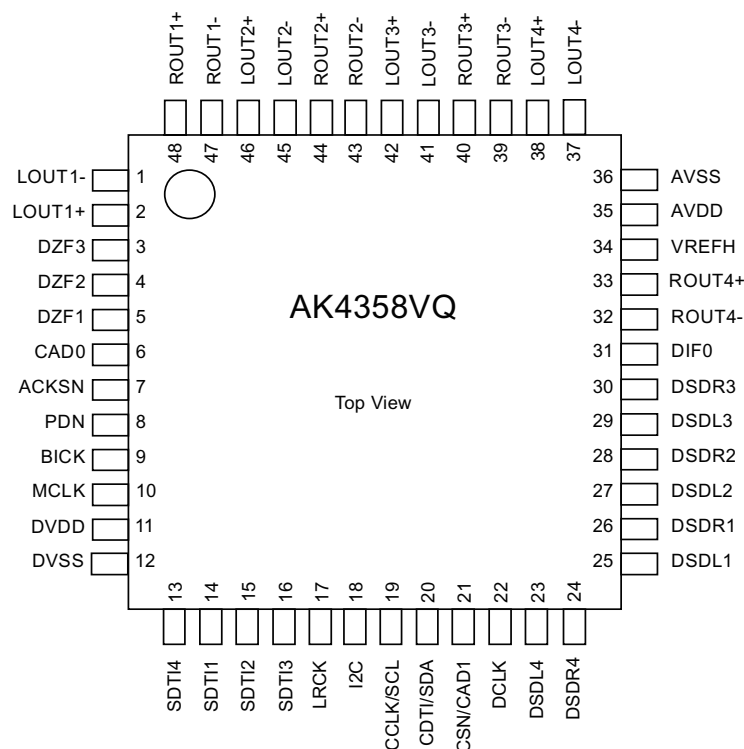

### AK4358VQ Pin Function

No.	Pin Name	I/O	Function
1	LOUT1-	O	DAC1 Lch Negative Analog Output Pin
2	LOUT1+	O	DAC1 Lch Positive Analog Output Pin
3	DZF3	O	Zero Input Detect 3 Pin
4	DZF2	O	Zero Input Detect 2 Pin
5	DZF1	O	Zero Input Detect 1 Pin
6	CAD0	I	Chip Address 0 Pin
7	ACKSN	I	Auto Setting Mode Disable Pin (Pull-down Pin) “L”: Auto Setting Mode, “H”: Manual Setting Mode
8	PDN	I	Power-Down Mode Pin When at “L”, the AK4358 is in the power-down mode and is held in reset. The AK4358 should always be reset upon power-up.
9	BICK	I	Audio Serial Data Clock Pin
10	MCLK	I	Master Clock Input Pin An external TTL clock should be input on this pin.
11	DVDD	-	Digital Power Supply Pin, +4.75~+5.25V
12	DVSS	-	Digital Ground Pin
13	SDTI4	I	DAC4 Audio Serial Data Input Pin
14	SDTI1	I	DAC1 Audio Serial Data Input Pin
15	SDTI2	I	DAC2 Audio Serial Data Input Pin
16	SDTI3	I	DAC3 Audio Serial Data Input Pin
17	LRCK	I	L/R Clock Pin
18	I2C	I	Control Mode Select Pin “L”: 3-wire Serial, “H”: I <sup>2</sup> C Bus
19	CCLK/SCL	I	Control Data Clock Pin I2C = “L”: CCLK (3-wire Serial), I2C = “H”: SCL (I <sup>2</sup> C Bus)
20	CDTI/SDA	I/O	Control Data Input Pin I2C = “L”: CDTI (3-wire Serial), I2C = “H”: SDA (I <sup>2</sup> C Bus)
21	CSN/CAD1	I	Chip Select Pin I2C = “L”: CSN (3-wire Serial), I2C = “H”: CAD1 (I <sup>2</sup> C Bus)
22	DCLK	I	DSD Clock Pin
23	DSDL4	I	DAC4 DSD Lch Data Input Pin
24	DSDR4	I	DAC4 DSD Rch Data Input Pin
25	DSDL1	I	DAC1 DSD Lch Data Input Pin
26	DSDR1	I	DAC1 DSD Rch Data Input Pin
27	DSDL2	I	DAC2DSD Lch Data Input Pin
28	DSDR2	I	DAC2 DSD Rch Data Input Pin

29	DSDL3	I	DAC3 DSD Lch Data Input Pin
30	DSDR3	I	DAC3 DSD Rch Data Input Pin
31	DIF0	I	Audio Data Interface Format 0 Pin
32	ROUT4-	O	DAC4 Rch Negative Analog Output Pin
33	ROUT4+	O	DAC4 Rch Positive Analog Output Pin
34	VREFH	I	Positive Voltage Reference Input Pin
35	AVDD	-	Analog Power Supply Pin, +4.75~+5.25V
36	AVSS	-	Analog Ground Pin
37	LOUT4-	O	DAC4 Lch Negative Analog Output Pin
38	LOUT4+	O	DAC4 Lch Positive Analog Output Pin
39	ROUT3-	O	DAC3 Rch Negative Analog Output Pin
40	ROUT3+	O	DAC3 Rch Positive Analog Output Pin
41	LOUT3-	O	DAC3 Lch Negative Analog Output Pin
42	LOUT3+	O	DAC3 Lch Positive Analog Output Pin
43	ROUT2-	O	DAC2 Rch Negative Analog Output Pin
44	ROUT2+	O	DAC2 Rch Positive Analog Output Pin
45	LOUT2-	O	DAC2 Lch Negative Analog Output Pin
46	LOUT2+	O	DAC2 Lch Positive Analog Output Pin
47	ROUT1-	O	DAC1 Rch Negative Analog Output Pin
48	ROUT1+	O	DAC1 Rch Positive Analog Output Pin

Note: All input pins except pull-down pin should not be left floating.

### AK4424ET (HDMI : U4404)

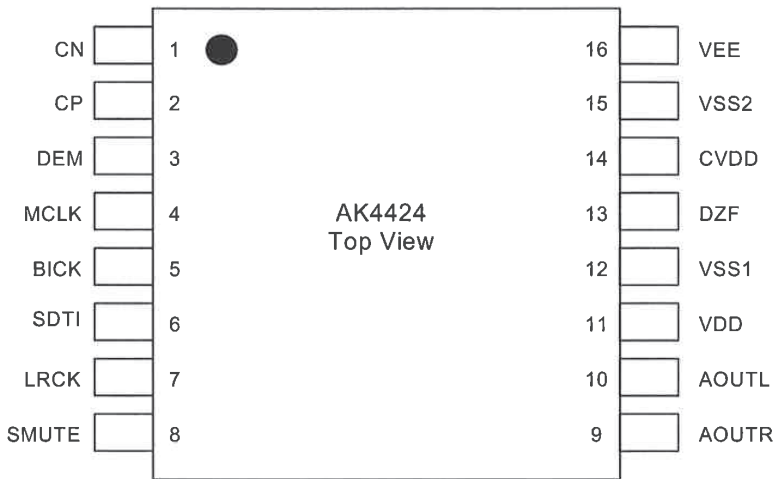

### AK4424ET Block Diagram

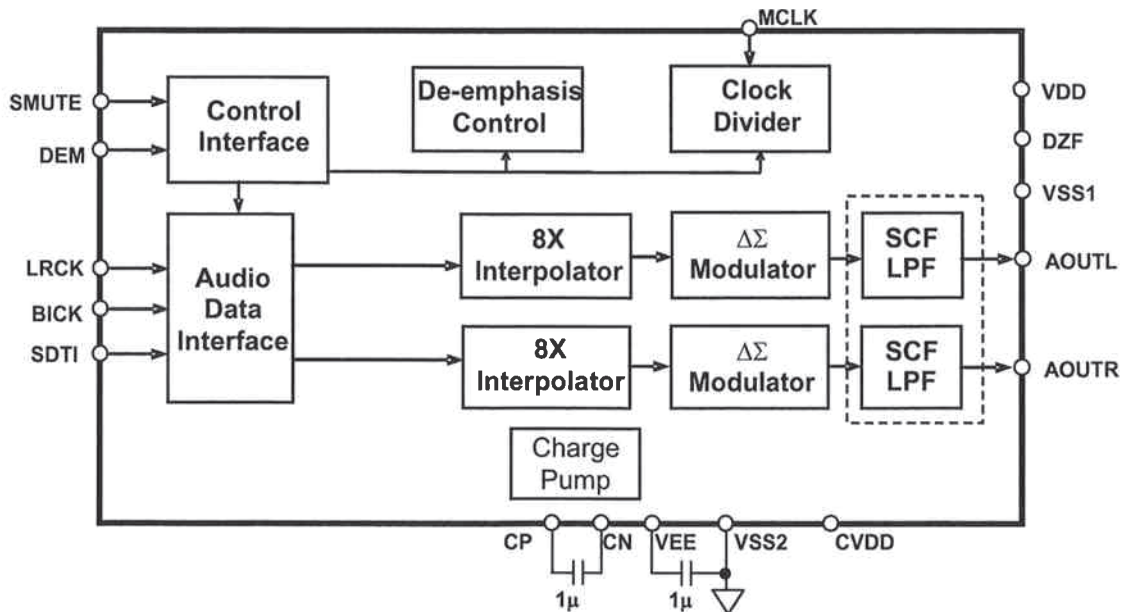

# IS42S16400F-6TL (HDMI : U4401)

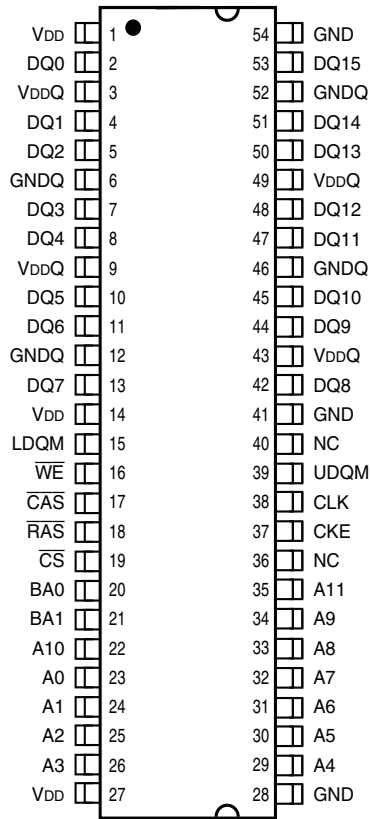

## PIN DESCRIPTIONS

A0-A11	Row Address Input
A0-A7	Column Address Input
BA0, BA1	Bank Select Address
DQ0 to DQ15	Data I/O
CLK	System Clock Input
CKE	Clock Enable
CS	Chip Select
RAS	Row Address Strobe Command
CAS	Column Address Strobe Command
WE	Write Enable
LDQM	x16 Lower Byte, Input/Output Mask
UDQM	x16 Upper Byte, Input/Output Mask
VDD	Power
GND	Ground
VDDQ	Power Supply for I/O Pin
GNDQ	Ground for I/O Pin
NC	No Connection

## IS42S16400F-6TL Block Diagram

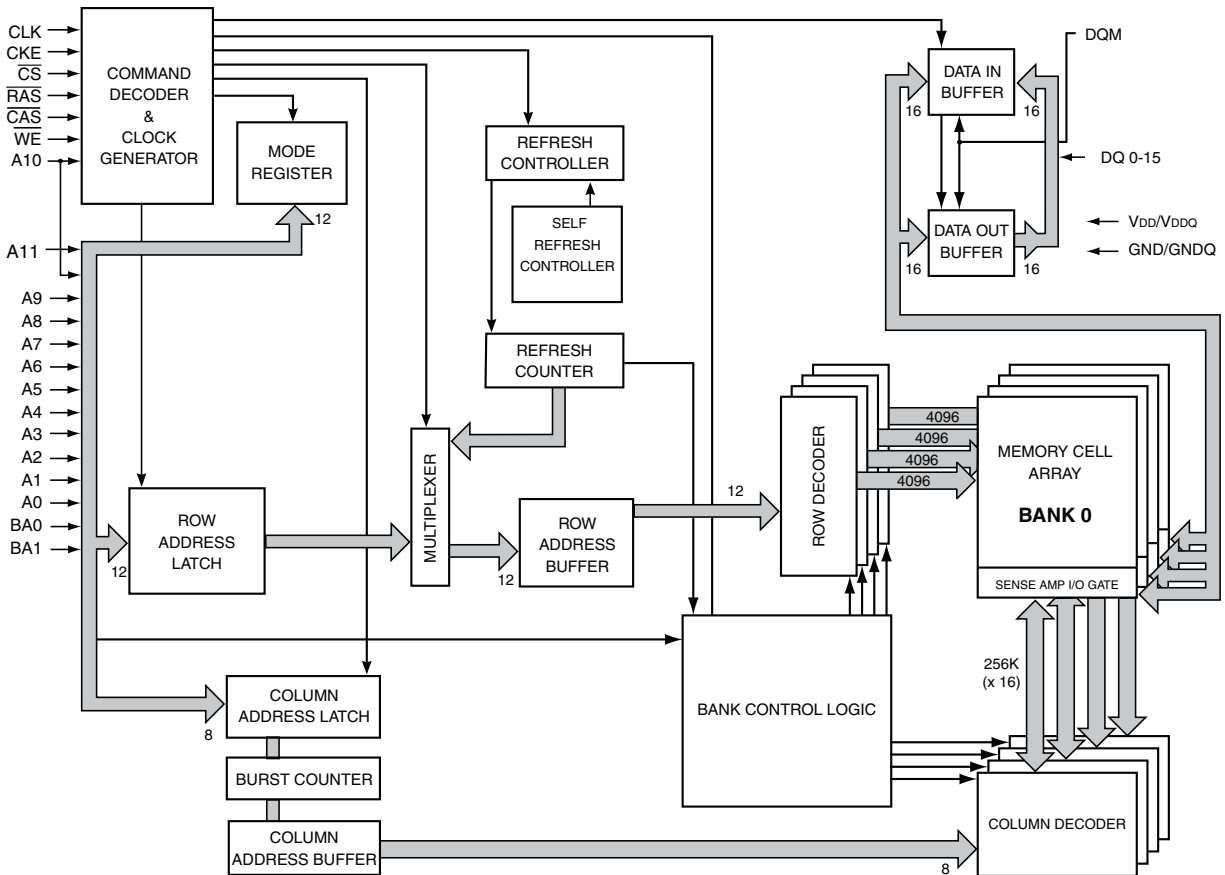

# TCC8600 (HDMI : U4403)

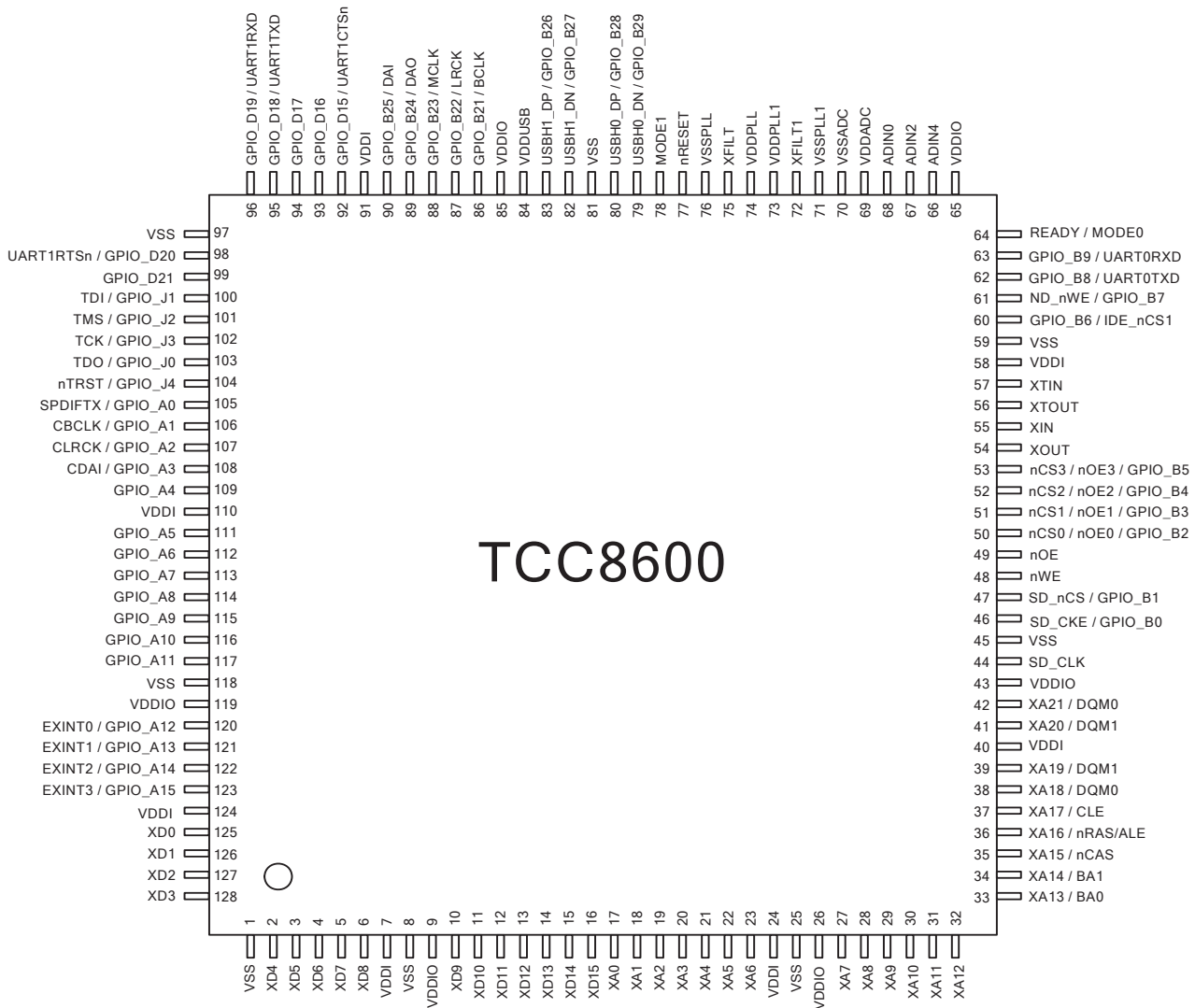

## TCC8600 Block Diagram

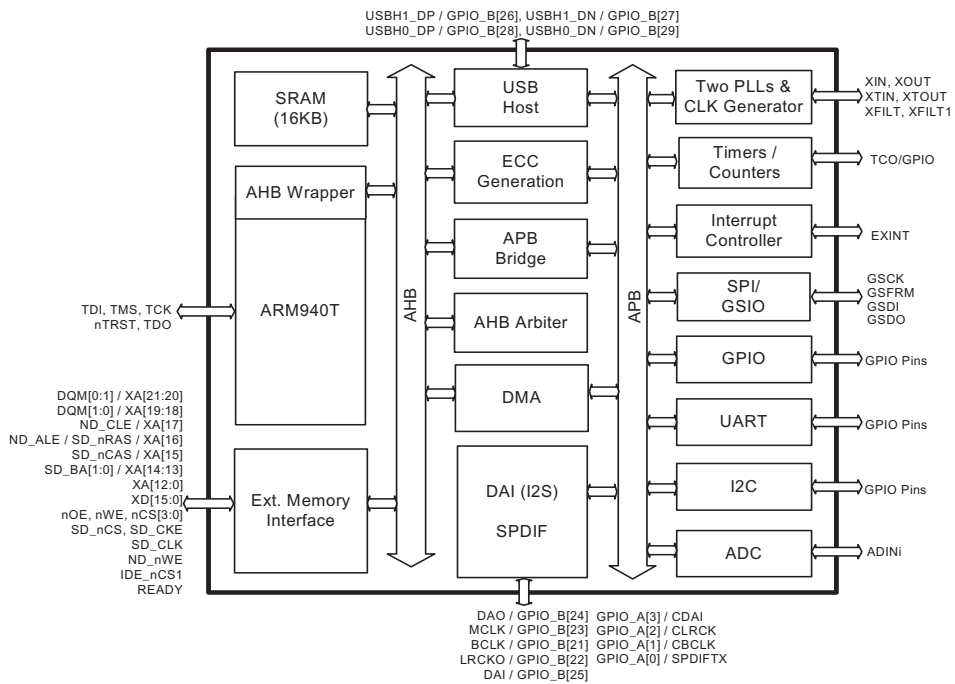

## TCC8600 Pin Description

Signal Name	Pin#	Type	Description – TCC8600
SD_CLK	44	I/O	SDRAM Clock
SD_CKE / GPIO_B[0]	46	I/O	SDRAM Clock Enable signal. Active high. / GPIO_B[0]
SD_nCS / GPIO_B[1]	47	I/O	Chip select signal for SDRAM, Active low / GPIO_B[1]
XA[21] / DQM[0]	42	I/O	External Bus Address Bit [21] / Data I/O Mask 0
XA[20] / DQM[1]	41	I/O	External Bus Address Bit [20] / Data I/O Mask 1
XA[19] / DQM[1]	39	I/O	External Bus Address Bit [19] / Data I/O Mask 1
XA[18] / DQM[0]	38	I/O	External Bus Address Bit [18] / Data I/O Mask 0
XA[17] / ND_CLE	37	I/O	External Bus Address Bit [17] / CLE for NAND Flash
XA[16] / SD_nRAS / ND_ALE	36	I/O	External Bus Address Bit [16] / SDRAM RAS signal / ALE for NAND Flash
XA[15] / SD_nCAS	35	I/O	External Bus Address Bit [15] / SDRAM CAS signal
XA[14] / SD_BA[1]	34	I/O	External Bus Address Bit [14] / SDRAM Bank Address 1
XA[13] / SD_BA[0]	33	I/O	External Bus Address Bit [13] / SDRAM Bank Address 0.
XA[12]	32	I/O	External Bus Address Bit [12]
XA[11]	31	I/O	External Bus Address Bit [11]
XA[10]	30	I/O	External Bus Address Bit [10]
XA[9]	29	I/O	External Bus Address Bit [9]
XA[8]	28	I/O	External Bus Address Bit [8]
XA[7]	27	I/O	External Bus Address Bit [7]
XA[6]	23	I/O	External Bus Address Bit [6]
XA[5]	22	I/O	External Bus Address Bit [5]
XA[4]	21	I/O	External Bus Address Bit [4]
XA[3]	20	I/O	External Bus Address Bit [3]
XA[2]	19	I/O	External Bus Address Bit [2]
XA[1]	18	I/O	External Bus Address Bit [1]
XA[0]	17	I/O	External Bus Address Bit [0]
XD[15]	16	I/O	External Bus Data Bit [15]. Internal pull-up resistor enabled at reset.
XD[14]	15	I/O	External Bus Data Bit [14]. Internal pull-up resistor enabled at reset.
XD[13]	14	I/O	External Bus Data Bit [13]. Internal pull-up resistor enabled at reset.
XD[12]	13	I/O	External Bus Data Bit [12]. Internal pull-up resistor enabled at reset.
XD[11]	12	I/O	External Bus Data Bit [11]. Internal pull-up resistor enabled at reset.
XD[10]	11	I/O	External Bus Data Bit [10]. Internal pull-up resistor enabled at reset.
XD[9]	10	I/O	External Bus Data Bit [9]. Internal pull-up resistor enabled at reset.
XD[8]	6	I/O	External Bus Data Bit [8]. Internal pull-up resistor enabled at reset.
XD[7]	5	I/O	External Bus Data Bit [7]. Internal pull-up resistor enabled at reset.
XD[6]	4	I/O	External Bus Data Bit [6]. Internal pull-up resistor enabled at reset.
XD[5]	3	I/O	External Bus Data Bit [5]. Internal pull-up resistor enabled at reset.
XD[4]	2	I/O	External Bus Data Bit [4]. Internal pull-up resistor enabled at reset.
XD[3]	128	I/O	External Bus Data Bit [3]. Internal pull-up resistor enabled at reset.
XD[2]	127	I/O	External Bus Data Bit [2]. Internal pull-up resistor enabled at reset.
XD[1]	126	I/O	External Bus Data Bit [1]. Internal pull-up resistor enabled at reset.
XD[0]	125	I/O	External Bus Data Bit [0]. Internal pull-up resistor enabled at reset.
nWE	48	I/O	Static Memory Write Enable signal. Active low.
nOE	49	I/O	Static Memory Output Enable signal. Active low.
ND_nWE / GPIO_B[7]	61	I/O	NAND flash WE. Active low. / GPIO_B[7]
nCS[3] / ND_nOE[3] / GPIO_B[5]	53	I/O	External Bus Chip Select [3] / NAND Flash Output Enable [3] / GPIO_B[5]
nCS[2] / ND_nOE[2] / GPIO_B[4]	52	I/O	External Bus Chip Select [2] / NAND Flash Output Enable [2] / GPIO_B[4]
nCS[1] / ND_nOE[1] / GPIO_B[3]	51	I/O	External Bus Chip Select [1] / NAND Flash Output Enable [1] / GPIO_B[3]
nCS[0] / ND_nOE[0] / GPIO_B[2]	50	I/O	External Bus Chip Select [0] / NAND Flash Output Enable [0] / GPIO_B[2]
READY / MODE0	64	I	Ready information from external device.
USBH1_DP / GPIO_B[26]	83	I/O	USB Host Port 1 D+ signal / GPIO_B[26]
USBH1_DN / GPIO_B[27]	82	I/O	USB Host Port 1 D- signal / GPIO_B[27]
USBH0_DP / GPIO_B[28]	80	I/O	USB Host Port 0 D+ signal / GPIO_B[28]
USBH0_DN / GPIO_B[29]	79	I/O	USB Host Port 0 D- signal / GPIO_B[29]

Signal Name	Pin#	Type	Description – TCC8600
GPIO_A[15] / EXINT[3]	123	I/O	GPIO_A[15] / External Interrupt Request [3]
GPIO_A[14] / EXINT[2]	122	I/O	GPIO_A[14] / External Interrupt Request [2]
GPIO_A[13] / EXINT[1]	121	I/O	GPIO_A[13] / External Interrupt Request [1]
GPIO_A[12] / EXINT[0]	120	I/O	GPIO_A[12] / External Interrupt Request [0]
GPIO_A[11]	117	I/O	GPIO_A[11] / I2C Clock / GPSB/GSIO3 Data In
GPIO_A[10]	116	I/O	GPIO_A[10] / I2C Data Line / GPSB/GSIO3 FRM
GPIO_A[9]	115	I/O	GPIO_A[9] / I2C Clock./ Bus Width (BW) / GPSB/GSIO3 Clock
GPIO_A[8]	114	I/O	GPIO_A[8] / I2C Data Line / GPSB/GSIO3 Data Output
GPIO_A[7]	113	I/O	GPIO_A[7] / GPSB/GSIO1 Data In
GPIO_A[6]	112	I/O	GPIO_A[6] / GPSB/GSIO1 FRM
GPIO_A[5]	111	I/O	GPIO_A[5] / GPSB/GSIO1 Clock
GPIO_A[4]	109	I/O	GPIO_A[4] / GPSB/GSIO1 Data Output
GPIO_A[3] / CDAI	108	I/O	CD Data Input / GPIO_A[3] / GPSB/GSIO1 Data In
GPIO_A[2] / CLRCK	107	I/O	CD Data Word Clock Input / GPIO_A[2] / GPSB/GSIO1 FRM
GPIO_A[1] / CBCLK	106	I/O	CD Data Bit Clock Input / GPIO_A[1] / GPSB/GSIO1 Clock
GPIO_A[0] / SPDIFTX	105	I/O	GPIO_A[0] / SPDIF TX Output / GPSB/GSIO1 Data Output
GPIO_B[25] / DAI	90	I/O	I2S Digital Audio data Input / GPIO_B[25]
GPIO_B[24] / DAO	89	I/O	I2S Digital Audio data Output / GPIO_B[24] / Boot Mode Bit 2 (BM[2])
GPIO_B[23] / MCLK	88	I/O	I2S System Clock / GPIO_B[23]
GPIO_B[22] / LRCK	87	I/O	I2S Word Clock / GPIO_B[22] / Boot Mode Bit 1 (BM[1])
GPIO_B[21] / BCLK	86	I/O	I2S Bit Clock / GPIO_B[21] / Boot Mode Bit 0 (BM[0])
GPIO_B[9] / UART0RXD	63	I/O	GPIO_B[9] / UART0 RX Data
GPIO_B[8] / UART0TXD	62	I/O	GPIO_B[8] / UART0 TX Data
GPIO_B[6] / IDE_nCS1	60	I/O	GPIO_B[6] / Chip select 1 for IDE Interface. Internal pull-up resistor enabled at reset.
GPIO_D[21]	99	I/O	GPIO_D[21]. Internal pull-up resistor enabled at reset.
GPIO_D[20] / UART1RTSn	98	I/O	GPIO_D[20] / UART1 RTS Output (active low). Internal pull-up resistor enabled at reset.
GPIO_D[19] / UART1RXD	96	I/O	GPIO_D[19] / UART1 RX Data. Internal pull-up resistor enabled at reset.
GPIO_D[18] / UART1TXD	95	I/O	GPIO_D[18] / UART1 TX Data. Internal pull-up resistor enabled at reset.
GPIO_D[17]	94	I/O	GPIO_D[17] / I2C SCL
GPIO_D[16]	93	I/O	GPIO_D[16] / I2C SDA
GPIO_D[15] / UART1CTSn	92	I/O	GPIO_D[15] / UART1 CTS Input (active low)
ADIN0	68	AI	General purpose multi-channel ADC input 0
ADIN2	67	AI	General purpose multi-channel ADC input 2
ADIN4	66	AI	General purpose multi-channel ADC input 4
XIN	55	I	12MHz Crystal Oscillator Input. Voltage must not exceed VDDI (1.95V).
XOUT	54	O	12MHz Crystal Oscillator Output
XTIN	57	I	32.768kHz Crystal Oscillator Input.Voltage must not exceed VDDI (1.95V).
XTOUT	56	O	32.768kHz Crystal Oscillator Output
XFILT	75	AO	PLL0 filter output. 350pF capacitor is required.
XFILT1	72	AO	PLL1 filter output. 1200pF capacitor is required.
TDI / GPIO_J[1]	100	I/O	JTAG serial data input. Internal pull-up resistor is enabled at reset
TMS / GPIO_J[2]	101	I/O	JTAG test mode select. Internal pull-up resistor is enabled at reset
TCK / GPIO_J[3]	102	I/O	JTAG test clock. Internal pull-up resistor is enabled at reset
TDO / GPIO_J[0]	103	I/O	JTAG serial data output. Internal pull-up resistor is enabled at reset
nTRST / GPIO_J[4]	104	I/O	JTAG reset signal. Active low.. Internal pull-up resistor is enabled at reset
MODE1	78	I	Mode Setting Input 1. Pull-down for normal operation.
nRESET	77	I	System Reset. Active low.
VDDIO	9	PWR	Digital Power for I/O (3.3V)
VDDIO	26	PWR	Digital Power for I/O (3.3V)
VDDIO	43	PWR	Digital Power for I/O (3.3V)
VDDIO	65	PWR	Digital Power for I/O (3.3V)
VDDIO	85	PWR	Digital Power for I/O (3.3V)
VDDIO	119	PWR	Digital Power for I/O (3.3V)
VDDUSB	84	PWR	Power for USB I/O (3.3V)
VDDI	7	PWR	Digital Power for Internal Core (1.8V)
VDDI	24	PWR	Digital Power for Internal Core (1.8V)
VDDI	40	PWR	Digital Power for Internal Core (1.8V)



Signal Name	Pin#	Type	Description – TCC8600
VDDI	58	PWR	Digital Power for Internal Core (1.8V)
VDDI	91	PWR	Digital Power for Internal Core (1.8V)
VDDI	110	PWR	Digital Power for Internal Core (1.8V)
VDDI	124	PWR	Digital Power for Internal Core (1.8V)
VDDADC	69	PWR	Analog Power for ADC (3.3V)
VDDPLL	74	PWR	Analog & Digital Power for PLL (1.8V)
VDDPLL1	73	PWR	Analog & Digital Power for PLL1 (1.8V)
VSS	1	GND	Digital Ground
VSS	8	GND	Digital Ground
VSS	25	GND	Digital Ground
VSS	45	GND	Digital Ground
VSS	59	GND	Digital Ground
VSS	81	GND	Digital Ground
VSS	97	GND	Digital Ground
VSS	118	GND	Digital Ground
VSSADC	70	GND	Analog Ground for ADC
VSSPLL	76	GND	Analog Ground for PLL
VSSPLL1	71	GND	Analog Ground for PLL

### TCC8600 Pin Description in Pin Number Order

Pin#	Signal Name	Type	Description – TCC8600
1	VSS	GND	Digital Ground
2	XD[4]	I/O	External Bus Data Bit [4]. Internal pull-up resistor enabled at reset.
3	XD[5]	I/O	External Bus Data Bit [5]. Internal pull-up resistor enabled at reset.
4	XD[6]	I/O	External Bus Data Bit [6]. Internal pull-up resistor enabled at reset.
5	XD[7]	I/O	External Bus Data Bit [7]. Internal pull-up resistor enabled at reset.
6	XD[8]	I/O	External Bus Data Bit [8]. Internal pull-up resistor enabled at reset.
7	VDDI	PWR	Digital Power for Internal Core (1.8V)
8	VSS	GND	Digital Ground
9	VDDIO	PWR	Digital Power for I/O (3.3V)
10	XD[9]	I/O	External Bus Data Bit [9]. Internal pull-up resistor enabled at reset.
11	XD[10]	I/O	External Bus Data Bit [10]. Internal pull-up resistor enabled at reset.
12	XD[11]	I/O	External Bus Data Bit [11]. Internal pull-up resistor enabled at reset.
13	XD[12]	I/O	External Bus Data Bit [12]. Internal pull-up resistor enabled at reset.
14	XD[13]	I/O	External Bus Data Bit [13]. Internal pull-up resistor enabled at reset.
15	XD[14]	I/O	External Bus Data Bit [14]. Internal pull-up resistor enabled at reset.
16	XD[15]	I/O	External Bus Data Bit [15]. Internal pull-up resistor enabled at reset.
17	XA[0]	I/O	External Bus Address Bit [0]
18	XA[1]	I/O	External Bus Address Bit [1]
19	XA[2]	I/O	External Bus Address Bit [2]
20	XA[3]	I/O	External Bus Address Bit [3]
21	XA[4]	I/O	External Bus Address Bit [4]
22	XA[5]	I/O	External Bus Address Bit [5]
23	XA[6]	I/O	External Bus Address Bit [6]
24	VDDI	PWR	Digital Power for Internal Core (1.8V)
25	VSS	GND	Digital Ground
26	VDDIO	PWR	Digital Power for I/O (3.3V)
27	XA[7]	I/O	External Bus Address Bit [7]
28	XA[8]	I/O	External Bus Address Bit [8]
29	XA[9]	I/O	External Bus Address Bit [9]
30	XA[10]	I/O	External Bus Address Bit [10]
31	XA[11]	I/O	External Bus Address Bit [11]
32	XA[12]	I/O	External Bus Address Bit [12]
33	XA[13] / SD_BA[0]	I/O	External Bus Address Bit [13] / SDRAM Bank Address 0.
34	XA[14] / SD_BA[1]	I/O	External Bus Address Bit [14] / SDRAM Bank Address 1
35	XA[15] / SD_nCAS	I/O	External Bus Address Bit [15] / SDRAM CAS signal

Pin#	Signal Name	Type	Description – TCC8600
36	XA[16] / SD_nRAS / ND_ALE	I/O	External Bus Address Bit [16] / SDRAM RAS signal / ALE for NAND Flash
37	XA[17] / ND_CLE	I/O	External Bus Address Bit [17] / CLE for NAND Flash
38	XA[18] / DQM[0]	I/O	External Bus Address Bit [18] / Data I/O Mask 0
39	XA[19] / DQM[1]	I/O	External Bus Address Bit [19] / Data I/O Mask 1
40	VDDI	PWR	Digital Power for Internal Core (1.8V)
41	XA[20] / DQM[1]	I/O	External Bus Address Bit [20] / Data I/O Mask 1
42	XA[21] / DQM[0]	I/O	External Bus Address Bit [21] / Data I/O Mask 0
43	VDDIO	PWR	Digital Power for I/O (3.3V)
44	SD_CLK	I/O	SDRAM Clock
45	VSS	GND	Digital Ground
46	SD_CKE / GPIO_B[0]	I/O	SDRAM Clock Enable signal. Active high. / GPIO_B[0]
47	SD_nCS / GPIO_B[1]	I/O	Chip select signal for SDRAM, Active low / GPIO_B[1]
48	nWE	I/O	Static Memory Write Enable signal. Active low.
49	nOE	I/O	Static Memory Output Enable signal. Active low.
50	nCS[0] / ND_nOE[0] / GPIO_B[2]	I/O	External Bus Chip Select [0] / NAND Flash Output Enable [0] / GPIO_B[2]
51	nCS[1] / ND_nOE[1] / GPIO_B[3]	I/O	External Bus Chip Select [1] / NAND Flash Output Enable [1] / GPIO_B[3]
52	nCS[2] / ND_nOE[2] / GPIO_B[4]	I/O	External Bus Chip Select [2] / NAND Flash Output Enable [2] / GPIO_B[4]
53	nCS[3] / ND_nOE[3] / GPIO_B[5]	I/O	External Bus Chip Select [3] / NAND Flash Output Enable [3] / GPIO_B[5]
54	XOUT	O	12MHz Crystal Oscillator Output
55	XIN	I	12MHz Crystal Oscillator Input. Voltage must not exceed VDDI (1.95V).
56	XTOUT	O	32.768kHz Crystal Oscillator Output
57	XTIN	I	32.768kHz Crystal Oscillator Input. Voltage must not exceed VDDI (1.95V).
58	VDDI	PWR	Digital Power for Internal Core (1.8V)
59	VSS	GND	Digital Ground
60	GPIO_B[6] / IDE_nCS1	I/O	GPIO_B[6] / Chip select 1 for IDE Interface. Internal pull-up resistor enabled at reset.
61	ND_nWE / GPIO_B[7]	I/O	NAND flash WE. Active low. / GPIO_B[7]
62	GPIO_B[8] / UART0TXD	I/O	GPIO_B[8] / UART0 TX Data
63	GPIO_B[9] / UART0RXD	I/O	GPIO_B[9] / UART0 RX Data
64	READY / MODE0	I	Ready information from external device.
65	VDDIO	PWR	Digital Power for I/O (3.3V)
66	ADIN4	AI	General purpose multi-channel ADC input 4
67	ADIN2	AI	General purpose multi-channel ADC input 2
68	ADIN0	AI	General purpose multi-channel ADC input 0
69	VDDADC	PWR	Analog Power for ADC (3.3V)
70	VSSADC	GND	Analog Ground for ADC
71	VSSPLL1	GND	Analog Ground for PLL
72	XFILT1	AO	PLL1 filter output. 1200pF capacitor is required.
73	VDDPLL1	PWR	Analog & Digital Power for PLL1 (1.8V)
74	VDDPLL	PWR	Analog & Digital Power for PLL (1.8V)
75	XFILT	AO	PLL0 filter output. 350pF capacitor is required.
76	VSSPLL	GND	Analog Ground for PLL
77	nRESET	I	System Reset. Active low.
78	MODE1	I	Mode Setting Input 1. Pull-down for normal operation.
79	USBH0_DN / GPIO_B[29]	I/O	USB Host Port 0 D- signal / GPIO_B[29]
80	USBH0_DP / GPIO_B[28]	I/O	USB Host Port 0 D+ signal / GPIO_B[28]
81	VSS	GND	Digital Ground
82	USBH1_DN / GPIO_B[27]	I/O	USB Host Port 1 D- signal / GPIO_B[27]
83	USBH1_DP / GPIO_B[26]	I/O	USB Host Port 1 D+ signal / GPIO_B[26]
84	VDDUSB	PWR	Power for USB I/O (3.3V)
85	VDDIO	PWR	Digital Power for I/O (3.3V)
86	GPIO_B[21] / BCLK	I/O	I2S Bit Clock / GPIO_B[21] / Boot Mode Bit 0 (BM[0])
87	GPIO_B[22] / LRCK	I/O	I2S Word Clock / GPIO_B[22] / Boot Mode Bit 1 (BM[1])
88	GPIO_B[23] / MCLK	I/O	I2S System Clock / GPIO_B[23]
89	GPIO_B[24] / DAO	I/O	I2S Digital Audio data Output / GPIO_B[24] / Boot Mode Bit 2 (BM[2])
90	GPIO_B[25] / DAI	I/O	I2S Digital Audio data Input / GPIO_B[25]
91	VDDI	PWR	Digital Power for Internal Core (1.8V)
92	GPIO_D[15] / UART1CTS <sub>n</sub>	I/O	GPIO_D[15] / UART1 CTS Input (active low)
93	GPIO_D[16]	I/O	GPIO_D[16] / I2C SDA

Pin#	Signal Name	Type	Description – TCC8600
94	GPIO_D[17]	I/O	GPIO_D[17] / I2C SCL
95	GPIO_D[18] / UART1TXD	I/O	GPIO_D[18] / UART1 TX Data. Internal pull-up resistor enabled at reset.
96	GPIO_D[19] / UART1RXD	I/O	GPIO_D[19] / UART1 RX Data. Internal pull-up resistor enabled at reset.
97	VSS	GND	Digital Ground
98	GPIO_D[20] / UART1RTSn	I/O	GPIO_D[20] / UART1 RTS Output (active low). Internal pull-up resistor enabled at reset.
99	GPIO_D[21]	I/O	GPIO_D[21]. Internal pull-up resistor enabled at reset.
100	TDI / GPIO_J[1]	I/O	JTAG serial data input. Internal pull-up resistor is enabled at reset
101	TMS / GPIO_J[2]	I/O	JTAG test mode select. Internal pull-up resistor is enabled at reset
102	TCK / GPIO_J[3]	I/O	JTAG test clock. Internal pull-up resistor is enabled at reset
103	TDO / GPIO_J[0]	I/O	JTAG serial data output. Internal pull-up resistor is enabled at reset
104	nTRST / GPIO_J[4]	I/O	JTAG reset signal. Active low.. Internal pull-up resistor is enabled at reset
105	GPIO_A[0] / SPDIFTX	I/O	GPIO_A[0] / SPDIF TX Output / GPSB/GSIO1 Data Output
106	GPIO_A[1] / CBCLK	I/O	CD Data Bit Clock Input / GPIO_A[1] / GPSB/GSIO1 Clock
107	GPIO_A[2] / CLRCK	I/O	CD Data Word Clock Input / GPIO_A[2] / GPSB/GSIO1 FRM
108	GPIO_A[3] / CDAI	I/O	CD Data Input / GPIO_A[3] / GPSB/GSIO1 Data In
109	GPIO_A[4]	I/O	GPIO_A[4] / GPSB/GSIO1 Data Output
110	VDDI	PWR	Digital Power for Internal Core (1.8V)
111	GPIO_A[5]	I/O	GPIO_A[5] / GPSB/GSIO1 Clock
112	GPIO_A[6]	I/O	GPIO_A[6] / GPSB/GSIO1 FRM
113	GPIO_A[7]	I/O	GPIO_A[7] / GPSB/GSIO1 Data In
114	GPIO_A[8]	I/O	GPIO_A[8] / I2C Data Line / GPSB/GSIO3 Data Output
115	GPIO_A[9]	I/O	GPIO_A[9] / I2C Clock./ Bus Width (BW) / GPSB/GSIO3 Clock
116	GPIO_A[10]	I/O	GPIO_A[10] / I2C Data Line / GPSB/GSIO3 FRM
117	GPIO_A[11]	I/O	GPIO_A[11] / I2C Clock / GPSB/GSIO3 Data In
118	VSS	GND	Digital Ground
119	VDDIO	PWR	Digital Power for I/O (3.3V)
120	GPIO_A[12] / EXINT[0]	I/O	GPIO_A[12] / External Interrupt Request [0]
121	GPIO_A[13] / EXINT[1]	I/O	GPIO_A[13] / External Interrupt Request [1]
122	GPIO_A[14] / EXINT[2]	I/O	GPIO_A[14] / External Interrupt Request [2]
123	GPIO_A[15] / EXINT[3]	I/O	GPIO_A[15] / External Interrupt Request [3]
124	VDDI	PWR	Digital Power for Internal Core (1.8V)
125	XD[0]	I/O	External Bus Data Bit [0]. Internal pull-up resistor enabled at reset.
126	XD[1]	I/O	External Bus Data Bit [1]. Internal pull-up resistor enabled at reset.
127	XD[2]	I/O	External Bus Data Bit [2]. Internal pull-up resistor enabled at reset.
128	XD[3]	I/O	External Bus Data Bit [3]. Internal pull-up resistor enabled at reset.

R2A15220FP (AUDIO : IC3003)

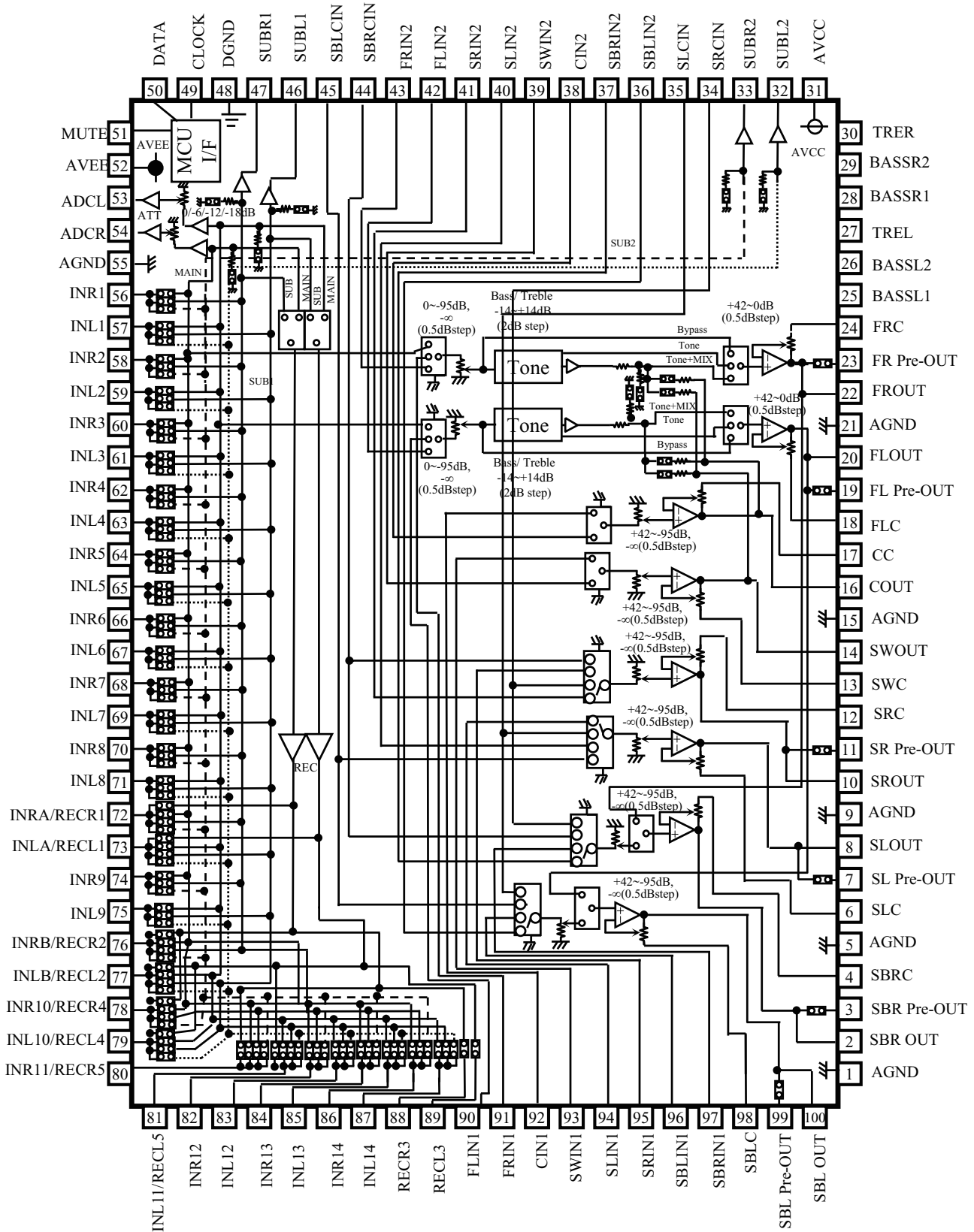

## R2A15220FP Pin Function

PIN No.	Name	Function
22,20, 16,14, 10, 8, 2, 100	FROUT,FLOUT, COUT,SWOUT, SROUT, SLOUT, SBROUT,SBLOUT	Output pin of FL/FR/C/SW/SL/SR/SBL/SBR channel
23,19, 11, 7, 3, 99	FR Pre-out,FL Pre-out, SR Pre-out, SL Pre-out, SBR Pre-out,SBL Pre-out	Pre-output pin of FL/FR/SL/SR/SBL/SBR channel
24,18, 17,13, 12, 6, 4, 98	FRC,FLC, CC,SWC, SRC,SLC, SBRC,SBLC	Connects capacitor for reducing click noise of L/R/C/SW/SL/SR/SBL/SBR channel volume
1,5,9,15, 21,55,98	AGND	Analog ground of internal circuit
27,30	TREL, TRER	Frequency characteristic setting pin of L/R channel tone control (Treble)
25,26, 28,29	BASSL1,BASSL2 BASSR1,BASSR2	Frequency characteristic setting pin of L/R channel tone control (Bass)
31	AVCC	Positive power supply to internal circuit
43,42, 41,40, 39,38, 37,36	FRIN2, FLIN2, SRN2,SLIN2, SWIN2,CIN2, SBRIN2,SBLIN2	Multi Input pin of L/R/C/SW/SL/SR/SBL/SBR channel (Multi IN 1/2)
90,91, 92,93, 94,95, 96,97	FLIN1, FRIN1, CIN1,SWIN1, SLIN1,SRIN1, SBLIN1,SBRIN1	
48	DGND	Digital ground of internal circuit
49	DATA	Input pin of control data
50	CLOCK	Input pin of control clock
52	AVEE	Negative power supply to internal circuit
57,59,61,63, 65,67,69,71, 75,83,85,87	INL1,INL2, INL3,INL4, INL5,INL6,INL7,INL8, INL9,INL12,INL13,INL14	Input pin of L/R channel (Input Selector)
56,58,60,62, 64,66,68,70, 74,82,84,86	INR1,INR2, INR3,INR4, INR5,INR6,INR7,INR8, INR9,INR12,INR13,INR14	
51	MUTE	Outside Mute Control PIN
44,45 34,35	SBRCIN,SBLCIN SRCIN,SLCIN	3 <sup>rd</sup> Multi Input pin for SBL/SBR/SL/SR channel Volume that is able to swap SBR/SBL with SR/SL
46,47 33,32	SUBL1,SUBR1 SUBL2,SUBR2	Output pin for L/R channel SUB1/SUB2 Output
53,54	ADCL, ADCR	Output pin for L/R channel ADC
88,89	RECR3,RECL3	Output pin for L/R channel REC Output
72,73, 76,77, 78,79 80,81	INRA/RECR1,INLA/RECL1, INRB/RECR2,INLB/RECL2, INR10/RECR4,INL10/RECL4, INR11/RECR5,INL11/RECL5	Input pin of L/R channel (Input Selector)/ Output pin for L/R channel REC Output

**NJW1194A (AUDIO : IC3007)**

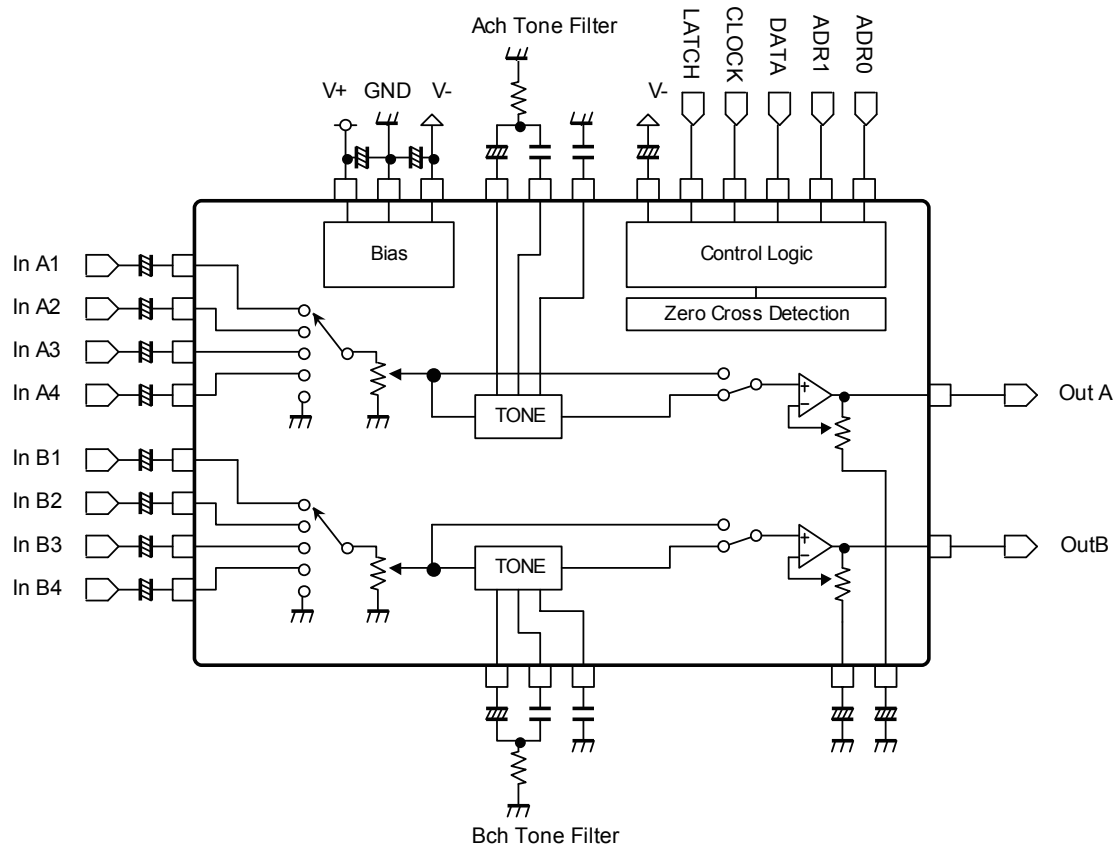



ANODE CONNECTION

	1G~16G	17G	18G	19G
D0A	1-1A	-	-	-
D1A	2-1A	-	-	-
D2A	3-1A	-	-	-
D3A	4-1A	-	-	-
D4A	5-1A	-	-	-
D5A	1-2A	-	-	-
D6A	2-2A	-	-	-
D7A	3-2A	-	-	-
D8A	4-2A	-	-	-
D9A	5-2A	-	-	-
D10A	1-3A	-	-	-
D11A	2-3A	-	-	dB
D12A	3-3A	-	-	Dp
D13A	4-3A	-	-	3d
D14A	5-3A	-	-	3e
D15A	1-4A	-	-	3c
D16A	2-4A	-	-	3g
D17A	3-4A	-	-	3f
D18A	4-4A	-	-	3b
D19A	5-4A	-	-	3a
D20A	1-5A	-	-	2d
D21A	2-5A	-	-	2e
D22A	3-5A	-	-	2c
D23A	4-5A	-	-	2g
D24A	5-5A	-	-	2f
D25A	1-6A	-	-	2b
D26A	2-6A	-	-	2a
D27A	3-6A	-	-	1d
D28A	4-6A	Z	-	1e
D29A	5-6A	X	-	1c
D30A	1-7A	II	-	1g
D31A	2-7A	PL	-	1f
D32A	3-7A	+	-	1b
D33A	4-7A	ES	-	1a
D34A	5-7A	HD	-	S2

	1G~16G	17G	18G	19G
D0B	1-1B	REC	-	-
D1B	2-1B	RDS	-	-
D2B	3-1B	AUTO	-	-
D3B	4-1B	TUNED	-	-
D4B	5-1B	DCI	-	-
D5B	1-2B	DCD	-	-
D6B	2-2B	DCI TrueHD	-	-
D7B	3-2B	96/24	-	-
D8B	4-2B	Express	-	-
D9B	5-2B	Nec:6	-	-
D10B	1-3B	STEREO	-	-
D11B	2-3B	MASTER	-	-
D12B	3-3B	-HD	-	MUTE
D13B	4-3B	dBs	ATTENDEE	S
D14B	5-3B	TAG	ORGANIZER	Q3
D15B	1-4B	MP3	PARTY	Q2
D16B	2-4B	WMA	EQ	Q1
D17B	3-4B	AAC	VOL	W
D18B	4-4B	PCM	DYN	2
D19B	5-4B	DSD	XT	1
D20B	1-5B	ANA.	MULTEQ	M
D21B	2-5B	DIG.	AUDYSSEY	H
D22B	3-5B	HDC	S1	SW3
D23B	4-5B	EXT2	SLEEP	SW2
D24B	5-5B	EXT1	RSTR	SW
D25B	1-6B	LFE	ANA.	FR
D26B	2-6B	FR	DIG.	C
D27B	3-6B	C	HDWI	FL
D28B	4-6B	FL	AUTO	SR
D29B	5-6B	SR	Z4	B
D30B	1-7B	S	Z3	A
D31B	2-7B	SL	Z2	SL
D32B	3-7B	SBR	AL24	SBR
D33B	4-7B	SB	DLINK	SB
D34B	5-7B	SBL	HDWI	SBL



# PARTS LIST OF P.C.B. UNIT

\* Parts for which "nsp" is indicated on this table cannot be supplied.

\* The parts listed below are for maintenance only, might differ from the parts used in the unit in appearances or dimensions.

**Note:** The symbols in the column "Remarks" indicate the following destinations.

U : North America model

N : Europe model

K : China model

B : Black model

SG : Silver gold model

## PCB 7CH\_AMP ASS'Y

Ref. No.	Part No.	Part Name	Remarks	Q'ty	New
<b>SEMICONDUCTORS GROUP</b>					
Q401,402	00D2710314903	TR 2SA KTA1024Y		J5001024Y0050S	
Q403	00D2710318909	TR 2SA 2N5401S		J520254010010S	
Q404	00D9630235301	TR 2SD2560Y		J5032560Y0170S	
Q405	00D2710318909	TR 2SA 2N5401S		J520254010010S	
Q406	00D2730479909	TR 2SC 2N5551S		J522255510010S	
Q407,408	00D9600196302	TR KTA1268BL		J5001268B0050S	
Q409	963219003340S	TR 2SC KTC3964		J502396400010S	
Q410	00D9630235204	TR 2SB1647Y		J5011647Y0170S	
Q411,412	00D2730471907	TR 2SC KTC3206Y		J5023206Y0050S	
Q413,414	00D2710314903	TR 2SA KTA1024Y		J5001024Y0050S	
Q415	00D2710318909	TR 2SA 2N5401S		J520254010010S	
Q416	00D9630235301	TR 2SD2560Y		J5032560Y0170S	
Q418	00D2730479909	TR 2SC 2N5551S		J522255510010S	
Q419,420	00D9600196302	TR KTA1268BL		J5001268B0050S	
Q421	963219003340S	TR 2SC KTC3964		J502396400010S	
Q422	00D9630235204	TR 2SB1647Y		J5011647Y0170S	
Q423,424	00D2730471907	TR 2SC KTC3206Y		J5023206Y0050S	
Q425,426	00D2710314903	TR 2SA KTA1024Y		J5001024Y0050S	
Q427	00D2710318909	TR 2SA 2N5401S		J520254010010S	
Q428	00D9630235301	TR 2SD2560Y		J5032560Y0170S	
Q430	00D2730479909	TR 2SC 2N5551S		J522255510010S	
Q431,432	00D9600196302	TR KTA1268BL		J5001268B0050S	
Q433	963219003340S	TR 2SC KTC3964		J502396400010S	
Q434	00D9630235204	TR 2SB1647Y		J5011647Y0170S	
Q435,436	00D2730471907	TR 2SC KTC3206Y		J5023206Y0050S	
Q437,438	00D2710314903	TR 2SA KTA1024Y		J5001024Y0050S	
Q439	00D2710318909	TR 2SA 2N5401S		J520254010010S	
Q440	00D9630235301	TR 2SD2560Y		J5032560Y0170S	
Q442	00D2730479909	TR 2SC 2N5551S		J522255510010S	
Q443,444	00D9600196302	TR KTA1268BL		J5001268B0050S	
Q445	963219003340S	TR 2SC KTC3964		J502396400010S	
Q446	00D9630235204	TR 2SB1647Y		J5011647Y0170S	
Q447,448	00D2730471907	TR 2SC KTC3206Y		J5023206Y0050S	
Q449,450	00D2710314903	TR 2SA KTA1024Y		J5001024Y0050S	
Q451	00D2710318909	TR 2SA 2N5401S		J520254010010S	
Q452	00D9630235301	TR 2SD2560Y		J5032560Y0170S	
Q454	00D2730479909	TR 2SC 2N5551S		J522255510010S	
Q455,456	00D9600196302	TR KTA1268BL		J5001268B0050S	
Q457	963219003340S	TR 2SC KTC3964		J502396400010S	
Q458	00D9630235204	TR 2SB1647Y		J5011647Y0170S	
Q459,460	00D2730471907	TR 2SC KTC3206Y		J5023206Y0050S	
Q461,462	00D2710314903	TR 2SA KTA1024Y		J5001024Y0050S	
Q463	00D2710318909	TR 2SA 2N5401S		J520254010010S	

	Ref. No.	Part No.	Part Name	Remarks		Q'ty	New
	Q464	00D9630235301	TR 2SD2560Y		J5032560Y0170S		
	Q466	00D2730479909	TR 2SC 2N5551S		J522255510010S		
	Q467,468	00D9600196302	TR KTA1268BL		J5001268B0050S		
	Q469	963219003340S	TR 2SC KTC3964		J502396400010S		
	Q470	00D9630235204	TR 2SB1647Y		J5011647Y0170S		
	Q471,472	00D2730471907	TR 2SC KTC3206Y		J5023206Y0050S		
	Q473,474	00D2710314903	TR 2SA KTA1024Y		J5001024Y0050S		
	Q475	00D2710318909	TR 2SA 2N5401S		J520254010010S		
	Q476	00D9630235301	TR 2SD2560Y		J5032560Y0170S		
	Q478	00D2730479909	TR 2SC 2N5551S		J522255510010S		
	Q479,480	00D9600196302	TR KTA1268BL		J5001268B0050S		
	Q481	963219003340S	TR 2SC KTC3964		J502396400010S		
	Q482	00D9630235204	TR 2SB1647Y		J5011647Y0170S		
	Q483,484	00D2730471907	TR 2SC KTC3206Y		J5023206Y0050S		
	D401-442	00D2760401905	D,SWITCHING 1SS133T		K000013300520S		
	D457,458	00D9630355401	D,SWITCHING KDS4148U		K005041480030S		
	ZD401	00D2760643983	D,ZENER MTZJ5.1A		K06005R134520S		
	ZD402,403	00D2760760934	D,ZENER MTZJ4.7B		K06004R744520S		
	ZD404	00D2760643983	D,ZENER MTZJ5.1A		K06005R134520S		
	ZD405,406	00D2760760934	D,ZENER MTZJ4.7B		K06004R744520S		
	ZD407	00D2760643983	D,ZENER MTZJ5.1A		K06005R134520S		
	ZD408,409	00D2760760934	D,ZENER MTZJ4.7B		K06004R744520S		
	ZD410	00D2760643983	D,ZENER MTZJ5.1A		K06005R134520S		
	ZD411,412	00D2760760934	D,ZENER MTZJ4.7B		K06004R744520S		
	ZD413	00D2760643983	D,ZENER MTZJ5.1A		K06005R134520S		
	ZD414,415	00D2760760934	D,ZENER MTZJ4.7B		K06004R744520S		
	ZD416	00D2760643983	D,ZENER MTZJ5.1A		K06005R134520S		
	ZD417,418	00D2760760934	D,ZENER MTZJ4.7B		K06004R744520S		
	ZD419	00D2760643983	D,ZENER MTZJ5.1A		K06005R134520S		
	ZD420,421	00D2760760934	D,ZENER MTZJ4.7B		K06004R744520S		
<b>RESISTORS GROUP</b>							
	R403	nsp	R,METAL FILM 270-J,1W		C060027165060S		
	R405	nsp	R,METAL FILM 270-J,1W		C060027165060S		
⚠	R406	252310006506S	POSISTOR PRF18BB471QB5RB		F320184710051S		
	R415	124050017503S	R,METAL FILM 22-J,1W		C060022065050S		
	R418	963125010690S	R,METAL FILM 15K-J,2W		C060015366050S		
	R424,425	124050016500S	R,FIXED 2WJ-0.47	FLAMERETARDANT	N113136647820S		
	R430,431	124050016500S	R,FIXED 2WJ-0.47	FLAMERETARDANT	N113136647820S		
	R434	nsp	R,METAL FILM 3.3K-J,1W		C060033265050S		
	R439	124050017503S	R,METAL FILM 22-J,1W		C060022065050S		
	R441,442	nsp	R,METAL FILM 1K-J,1W		C060010265050S		
	R443	nsp	R,METAL FILM 270-J,1W		C060027165060S		
	R447,448	nsp	R,METAL FILM 270-J,1W		C060027165060S		
⚠	R449	252310006520S	POSISTOR PRF18BD471QB5RB		F320184710150S		
⚠	R450	252310006506S	POSISTOR PRF18BB471QB5RB		F320184710051S		
	R458	124050017503S	R,METAL FILM 22-J,1W		C060022065050S		
	R461	963125010690S	R,METAL FILM 15K-J,2W		C060015366050S		
⚠	R464	252310006520S	POSISTOR PRF18BD471QB5RB		F320184710150S		

	Ref. No.	Part No.	Part Name	Remarks		Q'ty	New
	R467,468	124050016500S	R,FIXED 2WJ-0.47	FLAMERETARDANT	N113136647820S		
	R474,475	124050016500S	R,FIXED 2WJ-0.47	FLAMERETARDANT	N113136647820S		
	R478	nsp	R,METAL FILM 3.3K-J,1W		C060033265050S		
	R483	124050017503S	R,METAL FILM 22-J,1W		C060022065050S		
	R485,486	nsp	R,METAL FILM 1K-J,1W		C060010265050S		
	R487	nsp	R,METAL FILM 270-J,1W		C060027165060S		
	R491,492	nsp	R,METAL FILM 270-J,1W		C060027165060S		
△	R494	252310006506S	POSISTOR PRF18BB471QB5RB		F320184710051S		
	R502	124050017503S	R,METAL FILM 22-J,1W		C060022065050S		
	R505	963125010690S	R,METAL FILM 15K-J,2W		C060015366050S		
	R511,512	124050016500S	R,FIXED 2WJ-0.47	FLAMERETARDANT	N113136647820S		
	R517,518	124050016500S	R,FIXED 2WJ-0.47	FLAMERETARDANT	N113136647820S		
	R521	nsp	R,METAL FILM 3.3K-J,1W		C060033265050S		
	R526	124050017503S	R,METAL FILM 22-J,1W		C060022065050S		
	R528,529	nsp	R,METAL FILM 1K-J,1W		C060010265050S		
	R530	nsp	R,METAL FILM 270-J,1W		C060027165060S		
	R533	nsp	R,METAL FILM 270-J,1W		C060027165060S		
	R535	nsp	R,METAL FILM 270-J,1W		C060027165060S		
△	R537	252310006506S	POSISTOR PRF18BB471QB5RB		F320184710051S		
	R545	124050017503S	R,METAL FILM 22-J,1W		C060022065050S		
	R548	963125010690S	R,METAL FILM 15K-J,2W		C060015366050S		
	R554,555	124050016500S	R,FIXED 2WJ-0.47	FLAMERETARDANT	N113136647820S		
	R561,562	124050016500S	R,FIXED 2WJ-0.47	FLAMERETARDANT	N113136647820S		
	R564	nsp	R,METAL FILM 3.3K-J,1W		C060033265050S		
	R569	124050017503S	R,METAL FILM 22-J,1W		C060022065050S		
	R571,572	nsp	R,METAL FILM 1K-J,1W		C060010265050S		
	R573	nsp	R,METAL FILM 270-J,1W		C060027165060S		
	R576	nsp	R,METAL FILM 270-J,1W		C060027165060S		
	R578	nsp	R,METAL FILM 270-J,1W		C060027165060S		
△	R580	252310006506S	POSISTOR PRF18BB471QB5RB		F320184710051S		
	R588	124050017503S	R,METAL FILM 22-J,1W		C060022065050S		
	R591	963125010690S	R,METAL FILM 15K-J,2W		C060015366050S		
	R597,598	124050016500S	R,FIXED 2WJ-0.47	FLAMERETARDANT	N113136647820S		
	R603,604	124050016500S	R,FIXED 2WJ-0.47	FLAMERETARDANT	N113136647820S		
	R607	nsp	R,METAL FILM 3.3K-J,1W		C060033265050S		
	R612	124050017503S	R,METAL FILM 22-J,1W		C060022065050S		
	R614,615	nsp	R,METAL FILM 1K-J,1W		C060010265050S		
	R616	nsp	R,METAL FILM 270-J,1W		C060027165060S		
	R619	nsp	R,METAL FILM 270-J,1W		C060027165060S		
	R621	nsp	R,METAL FILM 270-J,1W		C060027165060S		
△	R623	252310006506S	POSISTOR PRF18BB471QB5RB		F320184710051S		
	R631	124050017503S	R,METAL FILM 22-J,1W		C060022065050S		
	R634	963125010690S	R,METAL FILM 15K-J,2W		C060015366050S		
	R640,641	124050016500S	R,FIXED 2WJ-0.47	FLAMERETARDANT	N113136647820S		
	R646,647	124050016500S	R,FIXED 2WJ-0.47	FLAMERETARDANT	N113136647820S		
	R650	nsp	R,METAL FILM 3.3K-J,1W		C060033265050S		
	R655	124050017503S	R,METAL FILM 22-J,1W		C060022065050S		
	R657,658	nsp	R,METAL FILM 1K-J,1W		C060010265050S		
	R659	nsp	R,METAL FILM 270-J,1W		C060027165060S		
	R662	nsp	R,METAL FILM 270-J,1W		C060027165060S		
	R664	nsp	R,METAL FILM 270-J,1W		C060027165060S		
△	R666	252310006506S	POSISTOR PRF18BB471QB5RB		F320184710051S		

	Ref. No.	Part No.	Part Name	Remarks		Q'ty	New
	R674	124050017503S	R,METAL FILM 22-J,1W		C060022065050S		
	R677	963125010690S	R,METAL FILM 15K-J,2W		C060015366050S		
	R683,684	124050016500S	R,FIXED 2WJ-0.47	FLAMERETARDANT	N113136647820S		
	R689,690	124050016500S	R,FIXED 2WJ-0.47	FLAMERETARDANT	N113136647820S		
	R694	nsp	R,METAL FILM 3.3K-J,1W		C060033265050S		
	R698	124050017503S	R,METAL FILM 22-J,1W		C060022065050S		
	R700,701	nsp	R,METAL FILM 1K-J,1W		C060010265050S		
	R702	nsp	R,METAL FILM 270-J,1W		C060027165060S		
	VR401-407	963161012400S	VR,SEMI CARBON EVN-DCAA03B 1KB		C541102315000S		
<b>CAPACITORS GROUP</b>							
	C401	nsp	C,CERAMIC 0.1UF-K/50V		D011104577160S		
	C403	nsp	C,CERAMIC 0.01UF-K/50V		D010103777160S		
	C405	nsp	C,CERAMIC 220PF-J/50V		D010221167160S		
	C406	nsp	C,CERAMIC SL220PF-J/500V		D00022106D051S		
	C407	00D9630234506	C,ELECT 47UF-M/50V (Pb Free)		D040470087070S		
	C408	00D9630224503	C,ELECT 22UF-M/50V		D040220087060S		
	C409	nsp	C,CERAMIC SL220PF-J/500V		D00022106D051S		
	C410	00D9609009937	C,ELECT 100UF-M/50V		D040101087060S		
	C411,412	nsp	C,CERAMIC 470PF-K/500V		D00447127D050S		
	C413	nsp	C,CERAMIC X7R2200PF-K/50V		D011222777200S		
	C415,416	00D9630234302	C,ELECT 10UF-M/100V		D04010008C050S		
	C418	nsp	C,CERAMIC 0.1UF-K/50V		D011104577160S		
	C421	nsp	C,CERAMIC 220PF-J/50V		D010221167160S		
	C422	nsp	C,CERAMIC SL220PF-J/500V		D00022106D051S		
	C423	00D9630234506	C,ELECT 47UF-M/50V (Pb Free)		D040470087070S		
	C424	00D9630224503	C,ELECT 22UF-M/50V		D040220087060S		
	C425	nsp	C,CERAMIC SL220PF-J/500V		D00022106D051S		
	C426	00D9609009937	C,ELECT 100UF-M/50V		D040101087060S		
	C427,428	nsp	C,CERAMIC 470PF-K/500V		D00447127D050S		
	C429	nsp	C,CERAMIC X7R2200PF-K/50V		D011222777200S		
	C431,432	00D9630234302	C,ELECT 10UF-M/100V		D04010008C050S		
	C434	nsp	C,CERAMIC 0.1UF-K/50V		D011104577160S		
	C437	nsp	C,CERAMIC 220PF-J/50V		D010221167160S		
	C438	nsp	C,CERAMIC SL220PF-J/500V		D00022106D051S		
	C439	00D9630234506	C,ELECT 47UF-M/50V (Pb Free)		D040470087070S		
	C440	00D9630224503	C,ELECT 22UF-M/50V		D040220087060S		
	C441	nsp	C,CERAMIC SL220PF-J/500V		D00022106D051S		
	C442	00D9609009937	C,ELECT 100UF-M/50V		D040101087060S		
	C443,444	nsp	C,CERAMIC 470PF-K/500V		D00447127D050S		
	C445	nsp	C,CERAMIC X7R2200PF-K/50V		D011222777200S		
	C447,448	00D9630234302	C,ELECT 10UF-M/100V		D04010008C050S		
	C450	nsp	C,CERAMIC 0.1UF-K/50V		D011104577160S		
	C453	nsp	C,CERAMIC 220PF-J/50V		D010221167160S		
	C454	nsp	C,CERAMIC SL220PF-J/500V		D00022106D051S		
	C455	00D9630234506	C,ELECT 47UF-M/50V (Pb Free)		D040470087070S		
	C456	00D9630224503	C,ELECT 22UF-M/50V		D040220087060S		
	C457	nsp	C,CERAMIC SL220PF-J/500V		D00022106D051S		
	C458	00D9609009937	C,ELECT 100UF-M/50V		D040101087060S		
	C459,460	nsp	C,CERAMIC 470PF-K/500V		D00447127D050S		

Ref. No.	Part No.	Part Name	Remarks	Q'ty	New
C461	nsp	C,CERAMIC X7R2200PF-K/50V		D011222777200S	
C463,464	00D9630234302	C,ELECT 10UF-M/100V		D04010008C050S	
C466	nsp	C,CERAMIC 0.1UF-K/50V		D011104577160S	
C469	nsp	C,CERAMIC 220PF-J/50V		D010221167160S	
C470	nsp	C,CERAMIC SL220PF-J/500V		D00022106D051S	
C471	00D9630234506	C,ELECT 47UF-M/50V (Pb Free)		D040470087070S	
C472	00D9630224503	C,ELECT 22UF-M/50V		D040220087060S	
C473	nsp	C,CERAMIC SL220PF-J/500V		D00022106D051S	
C474	00D9609009937	C,ELECT 100UF-M/50V		D040101087060S	
C475,476	nsp	C,CERAMIC 470PF-K/500V		D00447127D050S	
C477	nsp	C,CERAMIC X7R2200PF-K/50V		D011222777200S	
C479,480	00D9630234302	C,ELECT 10UF-M/100V		D04010008C050S	
C482	nsp	C,CERAMIC 0.1UF-K/50V		D011104577160S	
C485	nsp	C,CERAMIC 220PF-J/50V		D010221167160S	
C486	nsp	C,CERAMIC SL220PF-J/500V		D00022106D051S	
C487	00D9630234506	C,ELECT 47UF-M/50V (Pb Free)		D040470087070S	
C488	00D9630224503	C,ELECT 22UF-M/50V		D040220087060S	
C489	nsp	C,CERAMIC SL220PF-J/500V		D00022106D051S	
C490	00D9609009937	C,ELECT 100UF-M/50V		D040101087060S	
C491,492	nsp	C,CERAMIC 470PF-K/500V		D00447127D050S	
C493	nsp	C,CERAMIC X7R2200PF-K/50V		D011222777200S	
C495,496	00D9630234302	C,ELECT 10UF-M/100V		D04010008C050S	
C498	nsp	C,CERAMIC 0.1UF-K/50V		D011104577160S	
C501	nsp	C,CERAMIC 220PF-J/50V		D010221167160S	
C502	nsp	C,CERAMIC SL220PF-J/500V		D00022106D051S	
C503	00D9630234506	C,ELECT 47UF-M/50V (Pb Free)		D040470087070S	
C504	00D9630224503	C,ELECT 22UF-M/50V		D040220087060S	
C505	nsp	C,CERAMIC SL220PF-J/500V		D00022106D051S	
C506	00D9609009937	C,ELECT 100UF-M/50V		D040101087060S	
C507,508	nsp	C,CERAMIC 470PF-K/500V		D00447127D050S	
C509	nsp	C,CERAMIC X7R2200PF-K/50V		D011222777200S	
C511,512	00D9630234302	C,ELECT 10UF-M/100V		D04010008C050S	
C513,514	00D9630338402	C,ELECT 330UF-M/6.3V		D040331081050S	
C515	00D9639005820	C,ELECT 22UF-M/16V		D040220083070S	
<b>OTHERS PARTS GROUP</b>					
BKT400	nsp	BRACKET 0.8t/SCREW		4010210196100S	
CN404	nsp	CN.WIRE 5P		L002251052620S	
CP401	nsp	CN.WAFER 13P STRAIGHT		L101200101310S	
CP402	nsp	CN.WAFER 5P		L102526700500S	
CP403	nsp	CN.WAFER 10P STRAIGHT		L101200101010S	
CP405	nsp	CN.WAFER 3P		L102526700300S	
G400-402	nsp	CN,WIRE 1P		L000600010050S	
J538	nsp	CN,WIRE 1P		L045061000050S	
TP401-407	nsp	CN.WAFER 3P		L101200100320S	

## PCB SPK ASS'Y

	Ref. No.	Part No.	Part Name	Remarks		Q'ty	New
<b>SEMICONDUCTORS GROUP</b>							
△	IC100	963239010480S	IC PC123X2YFZ (DIP4P SHARP)		K614123000010S		
△	IC102	231010091708S	IC TOP258MG		G200258000010S		
	IC116	212050010508S	IC KIA2431AP		J126243118010S		
	Q1-7	00D9630120704	TR KRA102S(PB)		J520010200210S		
	Q8-14	00D9630120801	TR 2SC KRC102S (NB)		J522010200210S		
	D1-7	00D9630355401	D,SWITCHING KDS4148U		K005041480030S		
	D8	00D2760401905	D,SWITCHING 1SS133T		K000013300520S		
	D9,10	963209011740S	D,RECTIFIER BRIDGE D3SB60-5000		K047036040030S		
	D100-102	00D9630328409	D,SWITCHING 1N4007		K000400700010S		
	D103	203050018706S	D,SCHOTTKY D25SC6M 60V 25A		K120256000010S		
	D104-106	00D9630328409	D,SWITCHING 1N4007		K000400700010S		
	D108	963209010430S	D,FAST RECOVERY AP01C-V1 52RE-AX		K050000015000S		
	D109,110	00D9630328409	D,SWITCHING 1N4007		K000400700010S		
	D112	00D2760401905	D,SWITCHING 1SS133T		K000013300520S		
	ZD100	963202010440S	D,ZENER MTZJ22B		K06022R044520S		
	ZD101	00D2760762958	D,ZENER MTZJ39B	U1B	K06039R044520S		
	ZD102	963202010440S	D,ZENER MTZJ22B		K06022R044520S		
	ZD103	00D2760762958	D,ZENER MTZJ39B	U1B	K06039R044520S		
	ZD104	963202010440S	D,ZENER MTZJ22B		K06022R044520S		
	ZD105	00D2760762958	D,ZENER MTZJ39B	U1B	K06039R044520S		
	ZD106,107	963202010440S	D,ZENER MTZJ22B		K06022R044520S		
	ZD108,109	00D2760762958	D,ZENER MTZJ39B	U1B	K06039R044520S		
	ZD110	963202010440S	D,ZENER MTZJ22B	U1B	K06022R044520S		
	ZD110	00D2760762958	D,ZENER MTZJ39B	N1B,N1SG,K1B	K06039R044520S		
	ZD111	00D2760762958	D,ZENER MTZJ39B	N1B,N1SG,K1B	K06039R044520S		
	ZD112	963202010440S	D,ZENER MTZJ22B		K06022R044520S		
	ZD113	00D2760762958	D,ZENER MTZJ39B	N1B,N1SG,K1B	K06039R044520S		
	ZD114	00D9600095607	D,ZENER MTZJ5.6B		K06005R644520S		
	ZD115	00D2760762958	D,ZENER MTZJ39B		K06039R044520S		
	ZD116	00D2760762958	D,ZENER MTZJ39B	N1B,N1SG,K1B	K06039R044520S		
	ZD117,118	963202010440S	D,ZENER MTZJ22B		K06022R044520S		
	ZD119	00D2760762958	D,ZENER MTZJ39B	N1B,N1SG,K1B	K06039R044520S		
	TR100-102	00D9630255802	TR 2SC KTC3199Y		J5023199Y0010S		
<b>RESISTORS GROUP</b>							
	R5-17	963125010100S	R,METAL FILM 10-J 2W		C060010066050S		
	R28-33	00D9630310404	R,METAL FILM 2.2K-J,1W		C060022265050S		
	R34	nsp	R,METAL FILM 10K-J, 1/4W		C060103063050S		
	R37,38	963125010110S	R,METAL FILM 470-J,2W		C060047166060S		
	R39	963125010100S	R,METAL FILM 10-J 2W		C060010066050S		
<b>CAPACITORS GROUP</b>							
	C1	nsp	C,FILM MI-0.047UF-J/50V		D020473167050S		
	C2	nsp	C,CERAMIC 2200PF-K/50V		D011222777160S		
	C3,4	nsp	C,FILM MI-0.047UF-J/50V		D020473167050S		
	C5	nsp	C,CERAMIC 2200PF-K/50V		D011222777160S		

	Ref. No.	Part No.	Part Name	Remarks		Q'ty	New
	C6	nsp	C,FILM MI-0.047UF-J/50V		D020473167050S		
	C7	nsp	C,CERAMIC 2200PF-K/50V		D011222777160S		
	C8,9	nsp	C,FILM MI-0.047UF-J/50V		D020473167050S		
	C10	nsp	C,CERAMIC 2200PF-K/50V		D011222777160S		
	C11,12	nsp	C,FILM MI-0.047UF-J/50V		D020473167050S		
	C13	nsp	C,CERAMIC 2200PF-K/50V		D011222777160S		
	C14	nsp	C,FILM MI-0.047UF-J/50V		D020473167050S		
	C15	nsp	C,CERAMIC 2200PF-K/50V		D011222777160S		
	C16,17	nsp	C,FILM MI-0.047UF-J/50V		D020473167050S		
	C18	nsp	C,CERAMIC 2200PF-K/50V		D011222777160S		
	C19	nsp	C,FILM MI-0.047UF-J/50V		D020473167050S		
	C20	nsp	C,CERAMIC 2200PF-K/50V		D011222777160S		
	C21,22	nsp	C,FILM MI-0.047UF-J/50V		D020473167050S		
	C23	nsp	C,CERAMIC 2200PF-K/50V		D011222777160S		
	C24,25	nsp	C,FILM MI-0.047UF-J/50V		D020473167050S		
	C27	nsp	C,CERAMIC 1000PF-K/50V		D011102777160S		
	C30	nsp	C,CERAMIC 1000PF-K/50V		D011102777160S		
	C33	nsp	C,CERAMIC 1000PF-K/50V		D011102777160S		
	C36	nsp	C,CERAMIC 1000PF-K/50V		D011102777160S		
	C39	nsp	C,CERAMIC 1000PF-K/50V		D011102777160S		
	C42	nsp	C,CERAMIC 1000PF-K/50V		D011102777160S		
	C45	nsp	C,CERAMIC 1000PF-K/50V		D011102777160S		
	C48	nsp	C,CERAMIC 1000PF-K/50V		D011102777160S		
	C51	nsp	C,CERAMIC 1000PF-K/50V		D011102777160S		
	C53	00D9609009937	C,ELECT 100UF-M/50V		D040101087060S		
	C54	nsp	C,FILM 0.1UF-K/250V		D02010407H080S		
	C55	963134010180S	C,ELECT 12000UF-M/71V		D040123089550S		
	C57	00D9630234205	C,ELECT 10UF-M/50V		D040100087070S		
	C58	963134010180S	C,ELECT 12000UF-M/71V		D040123089550S		
	C60	00D9630244606	C,ELECT 0.1UF-M/50V (Pb Free)		D040R10087080S		
	C61	nsp	C,FILM 0.1UF-K/250V		D02010407H080S		
	C63	nsp	C,CERAMIC 1000PF-K/50V		D011102777160S		
△	C100	963132010140S	C,CERAMIC ECQU2A104ML 0.1UF		D00810408H000S		
	C102	963134010200S	C,ELECT 100UF-M/400V		D04110108K000S		
	C103	963132010120S	C,CERAMIC DEHR33A102KB2B		D00810207Q010S		
△	C104,105	963134011730S	C,CERAMIC DE1B3KX471KB4BL01 AC250V		D00847127H010S		
	C106-108	963134010220S	C,ELECT5600UF-M/6.3V		D041562081001S		
	C110	nsp	C,CERAMIC 0.1UF-K/25V		D011104774161S		
	C111	nsp	C,CERAMIC 4.7UF-K/6.3V		D011475571160S		
	C112	963134010190S	C,ELECT 10UF-M/50V		D041100087050S		
	C113	nsp	C,CERAMIC 0.1UF-K/25V		D011104774161S		
△	C115	963132011930S	C,CERAMIC DE1E3KX222MB4BL01 AC250V		D00822248H010S		
	C116	nsp	C,CERAMIC 0.1UF-K/25V		D011104774161S		
△	C117	963132011940S	C,CERAMIC DE2F3KY103MB3BM02 AC250V		D008103589010S		
	C118	nsp	C,CERAMIC 0.1UF-K/25V		D011104774161S		
	C119	963134010210S	C,ELECT 47UF-M/25V		D041470084050S		
	C120-123	nsp	C,CERAMIC 0.1UF-K/25V		D011104774161S		
△	C131	963132011940S	C,CERAMIC DE2F3KY103MB3BM02 AC250V		D008103589010S		
△	C133	963132011940S	C,CERAMIC DE2F3KY103MB3BM02 AC250V		D008103589010S		
<b>OTHERS PARTS GROUP</b>							
	BKT1-3	nsp	BRACKET t1.0+Sn plating /PCB MTG		4010214876000S		
	BKT101	nsp	BRACKET SCREW		4010210196000S		

Ref. No.	Part No.	Part Name	Remarks	Q'ty	New
CLAMP3	nsp	CLAMP WIRE(SOLDER)		4330000120000S	
CN1	nsp	CN,WIRE 230MM/5P 5264-05		L000231050050S	
CN2_WIR5	nsp	CN,WIRE 550MM/4P		L000901040050S	
CN3	nsp	CN,WIRE 2MM 170MM/10P 20010HS-10		L002171100050S	
CP1	nsp	CN.WAFER 35328-0360		L108353280360S	
CP12	nsp	CN.FPC 1.25MM 19P 127301119K2		L131019100010S	
CP22	nsp	CN.WAFER 5P TUC-P05P		L101100040510S	
CX102	nsp	CN.WAFER 7.92MM 35328-0263		L108353280290S	
CX104	nsp	CN.WAFER 5P TUC-P05X		L101100030510S	
CX105	nsp	CN,WIRE 370MM/5P TJC2508-5		L000371050050S	
⚠ F100	963652010510S	FUSE T2A/250V	U1B	N751502001160S	
⚠ F100	963652010500S	FUSE T1.6A/250V	N1B,N1SG,K1B	N751501601160S	
⚠ F101	963652010520S	FUSE T6.3A/250V	U1B	N751506301160S	
⚠ F101	963652010910S	FUSE T3.15A/250V	N1B,N1SG,K1B	N751503151160S	
J154,155	nsp	CN,WIRE 40MM/1P		L000400010020S	
J157	nsp	CN,WIRE 40MM/1P		L000400010020S	
J159	nsp	CN,WIRE 40MM/1P		L000400010020S	
JACK1	963643010360S	TER, BOARD 6P JB-602A-02		G613602A0200YS	
JACK2	963646001690S	TER, BOARD 8P MST-108V1		G614108V1010MS	
JACK3	00D9630257208	TER,BOARD SCREW 4P		G612405E0200YS	
⚠ JK100	00D2033958004	SOCKET,POWER AC INLET		G4300152P0001S	
L1-7	nsp	COIL INDUCTOR 0.5UH		D330R50000000S	
⚠ L100	963111010230S	COIL LINE FILTER LF-4ZB-E273H 27mH		D320402730020S	
⚠ RL101	963682010370S	RELAY HL31-1AT-5H 5V 1A		G680050102020S	
RLY1	00D9630218409	RELAY BC3-12 24V 2A		G680240202030S	
RLY2-7	963682002440S	RELAY 12V 5A SPK		G680120502050S	
DZ1	00D9600095801	D,ZENER MTZJ6.8B		K06006R844520S	
WIRE3	nsp	CN,WIRE 100MM/1P		L000101010120S	
WIRE4	nsp	CN,WIRE 80MM/1P		L000800010090S	
⚠ T100	963102010240S	TRANS,SWITCHING ST-4430A		E060044300010S	
	nsp	HOLDER,FUSE CLIP	F100_1	G645000050010S	
	nsp	HOLDER,FUSE CLIP	F100_2	G645000050010S	
	nsp	HOLDER,FUSE CLIP	F101_1	G645000050010S	
	nsp	HOLDER,FUSE CLIP	F101_2	G645000050010S	
	nsp	FUSE LABEL T1.6AL/250V	F100_LAB : N1B,N1SG,K1B	5507000006790S	
	nsp	FUSE LABEL T3.15AL/250V	N1B,N1SG,K1B	5507000006800S	
	nsp	CLAMP CABLE		4330040343010S	



## PCB REG\_CNT ASS'Y

	Ref. No.	Part No.	Part Name	Remarks		Q'ty	New
<b>SEMICONDUCTORS GROUP</b>							
	IC1	00D2631289900	IC AZ4580M	U1B	J121458000020S		
	IC103	00D2630553006	IC NJM7805FA		J126780500130S		
	IC104	00D2630554005	IC NJM7905FA		J126790500020S		
	IC105	00D2630553006	IC NJM7805FA		J126780500130S		
	IC106	00D2630810008	IC NJM7808FA		J126780800030S		
	IC107	00D2630503001	IC NJM7908FA		J126790800020S		
	IC108	963239010770S	IC NJM2388F09	N1B,N1SG,K1B	J126238800090S		
	IC109	231310009508S	IC PQ033DNA1ZPH	U1B	J126033010010S		
	IC401	00D2631289900	IC AZ4580M		J121458000020S		
	IC402	00D2631289900	IC AZ4580M	U1B	J121458000020S		
	IC403	231310009508S	IC PQ033DNA1ZPH		J126033010010S		
	IC404	963239008800S	IC ILX3232D		J046323200020S		
	IC405	00D2631286903	IC PQ120DNA1ZPH		J126120010010S		
	Q401,402	00D9630120704	TR KRA102S(PB)		J520010200210S		
	Q403,404	00D9630120801	TR 2SC KRC102S (NB)		J522010200210S		
	Q405	00D9630328302	TR 2SC KTC3875G(ALG)		J5223875G0210S		
	Q406	00D9630120704	TR KRA102S(PB)		J520010200210S		
	D114	00D9630236504	D,SCHOTTKY RB721Q-40		K120072140010S		
	D115,116	00D2760401905	D,SWITCHING 1SS133T		K000013300520S		
	D117,118	00D9630236504	D,SCHOTTKY RB721Q-40		K120072140010S		
	D119-121	00D2760401905	D,SWITCHING 1SS133T		K000013300520S		
	D122	00D9630236504	D,SCHOTTKY RB721Q-40		K120072140010S		
	D123	00D2760401905	D,SWITCHING 1SS133T	N1B,N1SG,K1B	K000013300520S		
	D124-134	00D9630328409	D,SWITCHING 1N4007		K000400700010S		
	D137-145	00D9630328409	D,SWITCHING 1N4007		K000400700010S		
	D401,402	00D9630355401	D,SWITCHING KDS4148U		K005041480030S		
	ZD117,118	00D9600096004	D,ZENER MTZJ33B		K06033R044520S		
	ZD401	00D2760665903	D,ZENER MTZJ16B		K06016R044520S		
<b>RESISTORS GROUP</b>							
	R46	nsp	R,CHIP 0-J,1/16W-1608		C20000006M160S		
<b>CAPACITORS GROUP</b>							
	C61	nsp	C,CERAMIC 33PF-J/50V	U1B	D010330167160S		
	C62,63	00D9630234205	C,ELECT 10UF-M/50V	U1B	D040100087070S		
	C64	nsp	C,CERAMIC 33PF-J/50V	U1B	D010330167160S		
	C65	nsp	C,CERAMIC 0.1UF-K/50V	U1B	D011104577160S		
	C66	nsp	C,CERAMIC 1UF-K/16V	U1B	D011105173161S		
	C67	nsp	C,CERAMIC 33PF-J/50V	U1B	D010330167160S		
	C68-70	00D9630234205	C,ELECT 10UF-M/50V	U1B	D040100087070S		
	C71	nsp	C,CERAMIC 0.1UF-K/50V	U1B	D011104777200S		
	C72	nsp	C,CERAMIC 33PF-J/50V	U1B	D010330167160S		
	C73	nsp	C,CERAMIC 1UF-K/16V	U1B	D011105173161S		
	C74	nsp	C,CERAMIC 0.1UF-K/50V	U1B	D011104577160S		
	C75	00D9630234205	C,ELECT 10UF-M/50V	U1B	D040100087070S		

	Ref. No.	Part No.	Part Name	Remarks		Q'ty	New
	C76-78	nsp	C,CERAMIC 100PF-J/50V	U1B	D010101167160S		
	C79	nsp	C,CERAMIC 0.1UF-K/50V	U1B	D011104577160S		
	C80,81	00D9630234205	C,ELECT 10UF-M/50V	U1B	D040100087070S		
	C126	00D9630217002	C,ELECT 3300UF-M/16V		D040332083010S		
	C127,128	00D9630234205	C,ELECT 10UF-M/50V		D040100087070S		
	C129	00D9630217002	C,ELECT 3300UF-M/16V		D040332083010S		
	C130	00D9630333203	C,ELECT 100UF-M/16V		D040101083090S		
	C131	00D9630234205	C,ELECT 10UF-M/50V		D040100087070S		
	C132	00D9630333203	C,ELECT 100UF-M/16V		D040101083090S		
	C133	90M-OA000500R	C,ELECT 4700UF-M/25V(MHA)		D040472084240S		
	C134	00D9630333203	C,ELECT 100UF-M/16V		D040101083090S		
	C135	90M-OA000500R	C,ELECT 4700UF-M/25V(MHA)		D040472084240S		
	C136	00D9630333203	C,ELECT 100UF-M/16V	N1B,N1SG,K1B	D040101083090S		
	C137	00D9630234205	C,ELECT 10UF-M/50V	N1B,N1SG,K1B	D040100087070S		
	C138	963134010700S	C,ELECT 2200UF-M/25V		D040222084030S		
	C142-144	nsp	C,FILM 0.1UF-J/50V		D020104167050S		
	C146-148	nsp	C,FILM 0.1UF-J/50V		D020104167050S		
	C401,402	nsp	C,CERAMIC 0.1UF-K/50V		D011104577160S		
	C403,404	nsp	C,CERAMIC 0.1UF-K/50V	U1B	D011104577160S		
	C405,406	00D9630234205	C,ELECT 10UF-M/50V		D040100087070S		
	C407,408	963134010940S	C,ELECT 10UF-M/16V	U1B	D040100083090S		
	C414	nsp	C,CERAMIC 1UF-K/16V		D011105173161S		
	C424	nsp	C,CERAMIC 1UF-K/16V		D011105173161S		
	C426	nsp	C,CERAMIC 0.1UF-K/50V		D011104577160S		
	C427	nsp	C,CERAMIC 0.1UF-K/50V	U1B	D011104577160S		
	C428-431	963134010940S	C,ELECT 10UF-M/16V		D040100083090S		
	C432-435	00D9630234205	C,ELECT 10UF-M/50V	U1B	D040100087070S		
	C436	nsp	C,CERAMIC 0.1UF-K/50V		D011104577160S		
	C437,438	nsp	C,CERAMIC 470PF-J/50V		D010471167160S		
	C439,440	nsp	C,CERAMIC 470PF-J/50V	U1B	D010471167160S		
	C441,442	nsp	C,CERAMIC 0.1UF-K/50V		D011104577160S		
	C443	nsp	C,CERAMIC 470PF-J/50V	U1B	D010471167160S		
	C444	nsp	C,CERAMIC 0.1UF-K/50V	U1B	D011104577160S		
	C445,446	nsp	C,CERAMIC 0.1UF-K/50V		D011104577160S		
	C448-451	nsp	C,CERAMIC 0.1UF-K/50V		D011104577160S		
	C452	00D9630234205	C,ELECT 10UF-M/50V		D040100087070S		
	C453	nsp	C,CERAMIC 0.1UF-K/50V		D011104577160S		
	C455	00D9630234205	C,ELECT 10UF-M/50V		D040100087070S		
	C456	nsp	C,CERAMIC 33PF-J/50V		D010330167160S		
	C457	00D9630234205	C,ELECT 10UF-M/50V		D040100087070S		
	C459	nsp	C,CERAMIC 33PF-J/50V		D010330167160S		
	C460	nsp	C,CERAMIC 0.1UF-K/50V		D011104577160S		
	C467,468	nsp	C,CERAMIC 0.1UF-K/50V		D011104577160S		
	C470	nsp	C,CERAMIC 4.7UF-K/6.3V		D011475571160S		
<b>OTHERS PARTS GROUP</b>							
	CLAMP100,101	nsp	CLAMP WIRE(SOLDER)		4330000120000S		
	CN4	nsp	CN,WAFER 15P C125Z2-15		L109012521510S		
	CN5	nsp	CN,WAFER 19P C125Z2-19		L109012521910S		
	CN9	nsp	CN,WAFER 17P C125Z2-17		L109012521710S		

Ref. No.	Part No.	Part Name	Remarks		Q'ty	New
CN10	nsp	CN,WAFER 15P C125Z2-15		L109012521510S		
CN11	nsp	CN,WAFER 25P C125Z2-25		L109012522510S		
CN13	nsp	CN,WIRE 13P 20010HS-13		L002121130010S		
CN15	nsp	CN.WAFER 4P 20010HS-04		L002161040091S		
CN100	nsp	CN,WAFER 13P C125Z2-13		L109012521310S		
CN101	nsp	CN,WAFER 11P C125Z2-11		L109012521110S		
CN104	nsp	CN,WAFER 27P C125Z2-27		L109012522710S		
CN401	nsp	CN,WAFER 11P C125Z2-11		L109012521110S		
CN402	nsp	CN,WAFER 15P C125Z1-15		L109012511510S		
CN403	nsp	CN,WAFER 19P C125Z1-19		L109012511910S		
CP3	nsp	CN,WAFER 11P C125Z1-11		L109012511110S		
CP4	nsp	CN,WAFER 25P C125Z1-25		L109012512510S		
CP6	nsp	CN,WAFER 19P C125Z1-19		L109012511910S		
CP7	nsp	CN,WAFER 17P C125Z1-17		L109012511710S		
CP8	nsp	CN,WAFER 15P C125Z1-15		L109012511510S		
CP13A	nsp	CN.WAFER 13P 20010WR-13		L101200101320S		
CP100	nsp	CN,WAFER 13P C125Z1-13		L109012511310S		
CP101	nsp	CN,WAFER 11P C125Z1-11		L109012511110S		
CP102	nsp	CN.WAFER 4P 5267-04A		L102526700400S		
CP104	nsp	CN.WAFER 3P		L102526700300S		
CP105	nsp	CN,WAFER 19P C125Z1-19		L109012511910S		
CP106	nsp	CN,WAFER 17P C125Z1-17		L109012511710S		
CP107	nsp	CN,WAFER 13P C125Z1-13		L109012511310S		
CP108	nsp	CN,WAFER 19P C125Z1-19		L109012511910S		
CP109	nsp	CN,WAFER 17P C125Z1-17		L109012511710S		
CP110	nsp	CN.WAFER 33P C125Z1-33		L109012513310S		
CP111	nsp	CN,WAFER 19P C125Z1-19		L109012511910S		
CP112	nsp	CN,WAFER 17P C125Z1-17		L109012511710S		
CP113,114	nsp	CN,WAFER 13P C125Z1-13		L109012511310S		
CP115	nsp	CN.WAFER 33P C125Z1-33		L109012513310S		
CP401	nsp	CN,WAFER 11P C125Z1-11		L109012511110S		
CP801	nsp	CN.FPC 1.25-2-13P	U1B	L131125021310S		
⚠ F104-108	963652010910S	FUSE T3.15A/250V		N751503151160S		
JACK401	963643012080M	JACK,DIN DIN-901B(MXJACK)		G403901B0000YS		
JACK402	00D9630333601	MINI DIN CONNECTOR 8P YKF51-5397N	U1B	G403515397000S		
JACK403	963646012090S	TER RCA 2PIN RCA-206B-02(OR,OR)		G601206B0200YS		
JACK404	nsp	CN.WAFER 9P		L103090090030S		
JACK405	nsp	JACK,D3.5 EARPHONE		G40130802000YS		
BK100	nsp	BRACKET SCREW		4010210196000S		
	nsp	LABEL FUSE		5507000005090S		
	nsp	HOLDER,FUSE CLIP	F104A-108A	G645000050010S		
	nsp	HOLDER,FUSE CLIP	F104B-108B	G645000050010S		

## PCB FRONT ASS'Y

	Ref. No.	Part No.	Part Name	Remarks		Q'ty	New
<b>SEMICONDUCTORS GROUP</b>							
	IC301	00D2631289900	IC AZ4580M		J121458000020S		
▲	IC304	00D9600195808	IC ICP-N15		J120001500030S		
	IC305	00D2631289900	IC AZ4580M		J121458000020S		
	Q300	00D9630226705	TR 2SC KTC1027Y		J5021027Y0020S		
	Q302	00D9600285006	TR KRC104S (ND)		J522104S00210S		
	Q309	00D9630328302	TR 2SC KTC3875G(ALG)		J5223875G0210S		
	Q311	00D9630120801	TR 2SC KRC102S (NB)		J522010200210S		
	Q313	00D9630120801	TR 2SC KRC102S (NB)		J522010200210S		
	Q314,315	00D9630328302	TR 2SC KTC3875G(ALG)		J5223875G0210S		
	Q317	00D9630120801	TR 2SC KRC102S (NB)		J522010200210S		
	Q318	00D9630120704	TR KRA102S(PB)		J520010200210S		
	Q320	00D9630120801	TR 2SC KRC102S (NB)		J522010200210S		
	D321,322	00D9630328409	D,SWITCHING 1N4007		K000400700010S		
	D330-332	963209003510S	D,ESD CDS3C05HDMI1		K067030500010S		
	ZD301	00D9630047405	D,ZENER MTZJ7.5B-0.5W		K06007R544520S		
	ZD303	00D2760761975	D,ZENER MTZJ18B		K06018R044520S		
	ZD304	00D2760762903	D,ZENER MTZJ24B		K06024R044520S		
	ZD307,308	00D9600095500	D,ZENER MTZJ5.1B		K06005R144520S		
	ZD318	00D9600095500	D,ZENER MTZJ5.1B		K06005R144520S		
	LED301	963263011010S	LED BZ-BB43V4V-2-TBS22A 5PI		K500056000100S		
	LED302	963263012110S	LED BL-BUF4V5K-1-AV-FP3.5 3PI RED		K500032000160S		
	LED304	963263012100S	LED BL-BVT201G 3PI RED/GREEN		K500032501130S		
<b>RESISTORS GROUP</b>							
	R399	00D9639006272	R,FIXED RSD-R1-1WJ-4.7	FLAMERETARDANT	N113135647920S		
<b>CAPACITORS GROUP</b>							
	C312	00D9630234205	C,ELECT 10UF-M/50V		D040100087060S		
	C314	963134005100S	C,ELECT 100UF-M/10V (Pb Free) SY		D040101082130S		
	C317	00D9630234205	C,ELECT 10UF-M/50V		D040100087070S		
	C318	nsp	C,CERAMIC 0.1UF-K/50V		D011104577160S		
	C319,320	nsp	C,FILM 0.1UF-J/100V		D02010406C060S		
	C321	nsp	C,CERAMIC 0.1UF-K/50V		D011104577160S		
	C322-324	nsp	C,CERAMIC 100PF-J/50V		D010101167160S		
	C325	nsp	C,CERAMIC 0.01UF-K/50V		D011103777162S		
	C326,327	nsp	C,CERAMIC 2200PF-J/50V		D011222777160S		
	C328	nsp	C,CERAMIC 0.1UF-K/50V		D011104577160S		
	C329	00D9630234205	C,ELECT 10UF-M/50V		D040100087070S		
	C330	nsp	C,CERAMIC 0.1UF-K/50V		D011104577160S		
	C331-333	00D9630234205	C,ELECT 10UF-M/50V		D040100087070S		
	C334	nsp	C,ELECT 220UF-M/6.3V		D040221081070S		
	C336	nsp	C,CERAMIC 0.1UF-K/50V		D011104577160S		
	C338	nsp	C,CERAMIC 100PF-J/50V		D010101167160S		
	C339	nsp	C,CERAMIC 0.1UF-K/50V		D011104577160S		

Ref. No.	Part No.	Part Name	Remarks	Q'ty	New
C340	00D9630293602	C,ELECT 1UF-M/50V (Pb Free)		D040010087150S	
C341,342	00D9630234205	C,ELECT 10UF-M/50V		D040100087070S	
C343	00D9630293602	C,ELECT 1UF-M/50V (Pb Free)		D040010087150S	
C346,347	nsp	C,CERAMIC 0.1UF-K/50V		D011104577160S	
C348	nsp	C,CERAMIC 100PF-J/50V		D010101167160S	
C349	00D9630234205	C,ELECT 10UF-M/50V		D040100087070S	
C350-356	nsp	C,CERAMIC 0.1UF-K/50V		D011104577160S	
C357	00D9630324607	C,ELECT 47UF-M/10V (Pb Free)		D040470082060S	
C358-361	nsp	C,CERAMIC 0.1UF-K/50V		D011104577160S	
C362	nsp	C,CERAMIC 0.001UF-J/50V		D010102167160S	
C363	nsp	C,CERAMIC 100PF-J/50V		D010101167160S	
C364	963134012120S	C,ELECT 100UF-M/63V		D040101088050S	
C366,367	00D9630293602	C,ELECT 1UF-M/50V (Pb Free)		D040010087150S	
C368-370	nsp	C,CERAMIC 100PF-J/50V		D010101167160S	
C373	nsp	C,CERAMIC 0.047UF-Z/50V		D011473597160S	
C384-387	nsp	C,CERAMIC 0.01UF-K/50V		D011103777162S	
<b>OTHERS PARTS GROUP</b>					
BD101	nsp	COIL,BEAD BLM21PG221SN1		D340201212210S	
BD102,103	nsp	CHIP BEADS(18PG121) +1608		D340160831210S	
CLAMP301-306	nsp	CLAMP WIRE(SOLDER)		4330000120000S	
CN300	nsp	CN.FPC 1.0MM 1.0-11S-40PW 40P		L130100114050S	
CN306	nsp	CN,WIRE 2MM 60MM/10P		L002600100020S	
CN307	nsp	CN,WIRE 2MM 650MM/5P		L002651050010S	
CP306	nsp	CN.WAFER 10P		L101200101020S	
CP308	nsp	CN,WAFER 5268-07A 7P ANGLE		L102526800700S	
JACK300	963649010300S	CN,PLUG DIP4P BK USBAS-00401B014-G		G480040101410S	
JACK301	963646012320S	TER,RCA 3PIN 328H-1-01		G606328H1010YS	
JACK303	963643006900M	PHONE (YUQIU) D6.5 9P SILVER PJ-612A		G402PJ612AN0YS	
JACK310	963643012350S	JACK,D3.5 EARPHONE		G401323A7000YS	
JACK365	262010004005S	MODULE TORX147L		E100147001010S	
RMC302	963262012130S	MODULE,REMOCON R34ES9A		E940349003610S	
SW301A	00D9630045708	SW,TACT SKHV10920A		G180000270010S	
SW301C	00D9630045708	SW,TACT SKHV10920A		G180000270010S	
SW302A	00D9630045708	SW,TACT SKHV10920A		G180000270010S	
SW302C	00D9630045708	SW,TACT SKHV10920A		G180000270010S	
SW303A	00D9630045708	SW,TACT SKHV10920A		G180000270010S	
SW303B	00D9630045708	SW,TACT SKHV10920A		G180000270010S	
SW303C	00D9630045708	SW,TACT SKHV10920A		G180000270010S	
SW304A	00D9630045708	SW,TACT SKHV10920A		G180000270010S	
SW304B	00D9630045708	SW,TACT SKHV10920A		G180000270010S	
SW305A	00D9630045708	SW,TACT SKHV10920A		G180000270010S	
SW305B	00D9630045708	SW,TACT SKHV10920A		G180000270010S	
SW306A	00D9630045708	SW,TACT SKHV10920A		G180000270010S	
SW306B	00D9630045708	SW,TACT SKHV10920A		G180000270010S	

	Ref. No.	Part No.	Part Name	Remarks		Q'ty	New
	SW307C	00D9630045708	SW,TACT SKHV10920A		G180000270010S		
	SW308A	00D9630045708	SW,TACT SKHV10920A		G180000270010S		
	SW309	00D9630045708	SW,TACT SKHV10920A		G180000270010S		
	VEC302	00D9630387408	SW,ENCODER EC16B24SO		G121162400070S		
	VEC304	963667012360S	SW,ENCODER EC16B24T01D4ZZZ		G121162400060S		
	FLT302	172010006108D	DISPLAY,FLT 19-ST-02GINK GREEN		K530190020010S		
		nsp	BRACKET FIP		4010214916000S		

**PCB VIDEO ASS'Y**

Ref. No.	Part No.	Part Name	Remarks	Q'ty	New
<b>SEMICONDUCTORS GROUP</b>					
U2003	235810046603S	IC AVDM2000(NJW1327)		J171132700010S	
U2004	231310009508S	IC PQ033DNA1ZPH		J126033010010S	
Q2001,2002	963219010750S	TR 2SA KTA1504G		J5201504G0210S	
Q2005	00D9630121606	TR KRC107S (NH)		J522107S00210S	
Q2006	00D9630120801	TR 2SC KRC102S (NB)		J522010200210S	
Q2009,2010	00D9630120801	TR 2SC KRC102S (NB)		J522010200210S	
D1003,1004	963209003510S	D,ESD CDS3C05HDMI1		K067030500010S	
D2001,2002	00D9630355401	D,SWITCHING KDS4148U		K005041480030S	
D2005,2006	00D9630355401	D,SWITCHING KDS4148U		K005041480030S	
D2009	00D9630328603	D,SCHOTTKY RB521S-30		K125521300010S	
<b>RESISTORS GROUP</b>					
R2001-2004	nsp	R,CHIP THICK 75-D,1/16W		C20007501M161S	
R2094	nsp	R,CHIP THICK 75-D,1/16W		C20007501M161S	
R2096	nsp	R,CHIP THICK 75-D,1/16W		C20007501M161S	
R2098	nsp	R,CHIP THICK 75-D,1/16W		C20007501M161S	
R2100,2101	nsp	R,CHIP THICK 75-D,1/16W		C20007501M161S	
R2107-2109	nsp	R,CHIP THICK 75-D,1/16W		C20007501M161S	
<b>CAPACITORS GROUP</b>					
C1001-1009	nsp	C,CERAMIC 10UF-K/10V		D011106572200S	
C1010-1012	nsp	R,THICK 0-J,1/10W		C200000060201S	
C2005-2008	00D9639005820	C,ELECT 22UF-M/16V		D040220083070S	
C2019,2020	nsp	C,CERAMIC 0.047UF-K/16V		D011473773160S	
C2023	nsp	C,CERAMIC0.01UF-K/50V		D011103777160S	
C2024	nsp	C,CERAMIC 0.1UF-K/50V		D011104577160S	
C2027,2028	nsp	C,CERAMIC 0.047UF-K/16V		D011473773160S	
C2031,2032	00D9630293602	C,ELECT 1UF-M/50V (Pb Free)		D040010087150S	
C2039,2040	nsp	C,CERAMIC 0.047UF-K/16V		D011473773160S	
C2045,2046	nsp	C,CERAMIC 0.1UF-K/50V		D011104577160S	
C2047	00D9639005820	C,ELECT 22UF-M/16V		D040220083070S	
C2048-2050	nsp	C,CERAMIC 0.1UF-K/50V		D011104577160S	
C2051	nsp	C,ELECT 47UF-M/16V		D040470083080S	
C2052	nsp	C,CERAMIC 0.1UF-K/50V		D011104577160S	
C2053	nsp	C,CERAMIC 1UF-K/16V		D011105173161S	
C2055,2056	nsp	C,CERAMIC 0.1UF-K/50V		D011104577160S	
C2058	nsp	C,CERAMIC 1UF-K/16V		D011105173161S	
C2059	nsp	C,CERAMIC 0.1UF-K/50V		D011104577160S	
C2060	00D9639005820	C,ELECT 22UF-M/16V		D040220083070S	
C2061-2064	nsp	C,CERAMIC 0.1UF-K/50V		D011104577160S	
C2065	nsp	C,ELECT 47UF-M/16V		D040470083080S	
C2066,2067	nsp	C,CERAMIC 0.1UF-K/50V		D011104577160S	
C2068	00D9639005820	C,ELECT 22UF-M/16V		D040220083070S	
C2070,2071	nsp	C,CERAMIC 0.1UF-K/50V		D011104577160S	
C2073	00D9639005820	C,ELECT 22UF-M/16V		D040220083070S	
C2074	nsp	C,ELECT 47UF-M/16V		D040470083080S	

Ref. No.	Part No.	Part Name	Remarks		Q'ty	New
C2079	nsp	C,CERAMIC 220PF-J/50V		D010221167160S		
<b>OTHERS PARTS GROUP</b>						
B2001	nsp	CN,WIRE 80MM/1P		L000800010110S		
B2003	nsp	CN,WIRE 80MM/1P		L000800010110S		
B2005	nsp	CN,WIRE 90MM/1P		L000900010110S		
K1001	963646012330S	TER,RCA 6PIN RCA-603A-54		G603603A0540YS		
K1012	963643010900S	TER,RCA 3PIN RCA-303A(2)		G606303A0800YS		
K1013	963643010900S	TER,RCA 3PIN RCA-303A(2)		G606303A0800YS		
K2001	963643003460S	TER,RCA 4PIN		G602405BE310YS		
K2003	963643010880S	TER,RCA 2PIN RCA-207B1		G601207B1050YS		
N2001	nsp	CN,WAFER 19P C125Z2-19		L109012521910S		
N2002	nsp	CN,WAFER 17P C125Z2-17		L109012521710S		
N2003	nsp	CN,WAFER 13P C125Z2-13		L109012521310S		
N2004	nsp	CN.WAFER 4P 20010WR-04		L101200100420S		



## PCB AUDIO ASS'Y

	Ref. No.	Part No.	Part Name	Remarks		Q'ty	New
<b>SEMICONDUCTORS GROUP</b>							
	IC3003	235810045600S	IC R2A15220FP		J084152200010S		
	IC3005,3006	00D2631289900	IC AZ4580M		J121458000020S		
	IC3007	00D2623727904	IC NJW1194A		J084119400010S		
	IC3008	00D2631289900	IC AZ4580M		J121458000020S		
	Q4001	00D9630044301	TR KTC2875B(MB)		J5222875B0010S		
	Q4002	00D9630121402	TR KRA104S		J520010400210S		
	Q4003	00D9630120704	TR KRA102S(PB)		J520010200210S		
	Q4005	00D9630044301	TR KTC2875B(MB)		J5222875B0010S		
	Q4006	00D9600285006	TR KRC104S (ND)		J522104S00210S		
	Q4015	00D9630044301	TR KTC2875B(MB)		J5222875B0010S		
	Q4016	00D9630121402	TR KRA104S		J520010400210S		
	Q4017	00D9630120704	TR KRA102S(PB)		J520010200210S		
	Q4019	00D9630044301	TR KTC2875B(MB)		J5222875B0010S		
	Q4020,4021	00D9600285006	TR KRC104S (ND)		J522104S00210S		
	Q4023	00D9630044301	TR KTC2875B(MB)		J5222875B0010S		
	Q4024	00D9630121402	TR KRA104S		J520010400210S		
	Q4025	00D9630120704	TR KRA102S(PB)		J520010200210S		
	Q4026	00D9630121402	TR KRA104S		J520010400210S		
	Q4027	00D9630120704	TR KRA102S(PB)		J520010200210S		
	Q4029	00D9630044301	TR KTC2875B(MB)		J5222875B0010S		
	Q4030	00D9600285006	TR KRC104S (ND)		J522104S00210S		
	Q4032	00D9630044301	TR KTC2875B(MB)		J5222875B0010S		
	Q4033	00D9630121402	TR KRA104S		J520010400210S		
	Q4034	00D9630120704	TR KRA102S(PB)		J520010200210S		
	Q4036	00D9630044301	TR KTC2875B(MB)		J5222875B0010S		
	Q4037	00D9600285006	TR KRC104S (ND)		J522104S00210S		
	Q4039	00D9630044301	TR KTC2875B(MB)		J5222875B0010S		
	Q4040	00D9630121402	TR KRA104S		J520010400210S		
	Q4041	00D9630120704	TR KRA102S(PB)		J520010200210S		
	Q4043	00D9630044301	TR KTC2875B(MB)		J5222875B0010S		
	Q4044,4045	00D9600285006	TR KRC104S (ND)		J522104S00210S		
	Q4047	00D9630044301	TR KTC2875B(MB)		J5222875B0010S		
	Q4048	00D9630121402	TR KRA104S		J520010400210S		
	Q4049	00D9630120704	TR KRA102S(PB)		J520010200210S		
	Q4098,4099	963219010760S	TR 2SC KRC231S(NW)	N1B,N1SG,K1B	J5220231M0010S		
	Q4100	00D9630120801	TR 2SC KRC102S (NB)	N1B,N1SG,K1B	J522010200210S		
	Q4101	963219010740S	TR 2SA KRA111S	N1B,N1SG,K1B	J520011100210S		
	Q4102	00D9630120801	TR 2SC KRC102S (NB)	N1B,N1SG,K1B	J522010200210S		
	D3023	00D9630328409	D,SWITCHING 1N4007		K000400700010S		
	D3025	00D9630328409	D,SWITCHING 1N4007		K000400700010S		
	D4000-4002	00D9630328409	D,SWITCHING 1N4007		K000400700010S		
	ZD4000	00D2760693962	D,ZENER 0.2W 3.6V UDZ		K06603R64P400S		
<b>CAPACITORS GROUP</b>							
	C3001-3012	00D9630234205	C,ELECT 10UF-M/50V		D040100087070S		
	C3021	nsp	C,CERAMIC 330PF-J/50V		D010331167160S		

	Ref. No.	Part No.	Part Name	Remarks		Q'ty	New
	C3029	nsp	C,CERAMIC 330PF-J/50V		D010331167160S		
	C3036,3037	00D9630234205	C,ELECT 10UF-M/50V		D040100087070S		
	C3038,3039	00D9609009937	C,ELECT 100UF-M/50V		D040101087060S		
	C3042	nsp	C,CERAMIC 330PF-J/50V		D010331167160S		
	C3047,3048	nsp	R,CHIP 0-J, 1/16W		C20000006M160S		
	C3049	nsp	C,CERAMIC 330PF-J/50V		D010331167160S		
	C3053	00D9630333203	C,ELECT 100UF-M/16V		D040101083090S		
	C3056	nsp	C,CERAMIC 330PF-J/50V		D010331167160S		
	C3058	nsp	C,CERAMIC 330PF-J/50V		D010331167160S		
	C3059	00D9630333203	C,ELECT 100UF-M/16V		D040101083090S		
	C3062	963134010710S	C,ELECT 47UF-M/35V		D040470085060S		
	C3065	nsp	C,CERAMIC 330PF-J/50V		D010331167160S		
	C3066,3067	963134010710S	C,ELECT 47UF-M/35V		D040470085060S		
	C3068	nsp	C,CERAMIC 330PF-J/50V		D010331167160S		
	C3072	nsp	C,CERAMIC 330PF-J/50V		D010331167160S		
	C3073,3074	963134010710S	C,ELECT 47UF-M/35V		D040470085060S		
	C3075	nsp	C,CERAMIC 330PF-J/50V		D010331167160S		
	C3079	963134010710S	C,ELECT 47UF-M/35V		D040470085060S		
	C3087,3088	nsp	C,CERAMIC 330PF-J/50V		D010331167160S		
	C3090	00D9630234205	C,ELECT 10UF-M/50V		D040100087070S		
	C3091,3092	nsp	C,CERAMIC 0.01UF-K/50V		D010103777160S		
	C3093	nsp	C,CERAMIC 68PF-J/50V		D010680167160S		
	C3094	nsp	C,CERAMIC 100PF-J/50V		D010101167160S		
	C3095-3097	00D9630234205	C,ELECT 10UF-M/50V		D040100087070S		
	C3098	nsp	C,CERAMIC 3300PF-K/50V		D011332777160S		
	C3099	nsp	C,CERAMIC 0.1UF-K/50V		D011104577160S		
	C3100	00D9630294203	C,ELECT 33UF-M/16V		D040330083050S		
	C3101	00D9630234205	C,ELECT 10UF-M/50V		D040100087070S		
	C3102	00D9609010010	C,ELECT 4.7UF-M/50V		D0404R7087250S		
	C3103	00D9630234205	C,ELECT 10UF-M/50V		D040100087070S		
	C3104	00D9630294203	C,ELECT 33UF-M/16V		D040330083050S		
	C3105	00D9630234205	C,ELECT 10UF-M/50V		D040100087070S		
	C3106	00D9609010010	C,ELECT 4.7UF-M/50V		D0404R7087250S		
	C3107	nsp	C,CERAMIC 0.1UF-K/50V		D011104577160S		
	C3108	00D9630234205	C,ELECT 10UF-M/50V		D040100087070S		
	C3110	00D9630234205	C,ELECT 10UF-M/50V		D040100087070S		
	C3111	nsp	C,CERAMIC 3300PF-K/50V		D011332777160S		
	C3112	00D9630234205	C,ELECT 10UF-M/50V		D040100087070S		
	C3113,3114	nsp	C,CERAMIC 0.01UF-K/50V		D010103777160S		
	C3115	nsp	C,CERAMIC 330PF-J/50V		D010331167160S		
	C3116	nsp	C,CERAMIC 68PF-J/50V		D010680167160S		
	C3117	nsp	C,CERAMIC 100PF-J/50V		D010101167160S		
	C3118,3119	nsp	R,CHIP 0-J, 1/16W		C20000006M160S		
	C3120	nsp	C,CERAMIC 330PF-J/50V		D010331167160S		
	C3121	00D9630234205	C,ELECT 10UF-M/50V		D040100087070S		
	C3124	nsp	C,CERAMIC 330PF-J/50V		D010331167160S		
	C3135	nsp	C,CERAMIC 330PF-J/50V		D010331167160S		
	C3141	nsp	C,CERAMIC 330PF-J/50V		D010331167160S		
	C3144,3145	nsp	R,CHIP 0-J, 1/16W		C20000006M160S		
	C3146	nsp	C,CERAMIC 330PF-J/50V		D010331167160S		
	C3161,3162	nsp	C,CERAMIC 330PF-J/50V		D010331167160S		
	C3164,3165	nsp	R,CHIP 0-J, 1/16W		C20000006M160S		

Ref. No.	Part No.	Part Name	Remarks	Q'ty	New
C4000	00D9630234205	C,ELECT 10UF-M/50V		D040100087070S	
C4001,4002	00D9630224503	C,ELECT 22UF-M/50V		D040220087060S	
C4003	nsp	C,CERAMIC 330PF-J/50V		D010331167160S	
C4004	nsp	C,CERAMIC 0.01UF-K/50V		D010103777160S	
C4005	nsp	C,CERAMIC 330PF-J/50V		D010331167160S	
C4006	00D9609010023	C,ELECT 0.47UF-M/50V		D040R47087050S	
C4007,4008	00D9630224503	C,ELECT 22UF-M/50V		D040220087060S	
C4017,4018	00D9630224503	C,ELECT 22UF-M/50V		D040220087060S	
C4019	nsp	C,CERAMIC 330PF-J/50V		D010331167160S	
C4020	nsp	C,CERAMIC 0.01UF-K/50V		D010103777160S	
C4021	nsp	C,CERAMIC 330PF-J/50V		D010331167160S	
C4022	00D9609010023	C,ELECT 0.47UF-M/50V		D040R47087050S	
C4023-4026	00D9630224503	C,ELECT 22UF-M/50V		D040220087060S	
C4027	nsp	C,CERAMIC 330PF-J/50V		D010331167160S	
C4028	00D9609010023	C,ELECT 0.47UF-M/50V		D040R47087050S	
C4029	nsp	C,CERAMIC 0.01UF-K/50V		D010103777160S	
C4030	nsp	C,CERAMIC 330PF-J/50V		D010331167160S	
C4031	00D9609010023	C,ELECT 0.47UF-M/50V		D040R47087050S	
C4032-4035	00D9630224503	C,ELECT 22UF-M/50V		D040220087060S	
C4036	nsp	C,CERAMIC 330PF-J/50V		D010331167160S	
C4037	nsp	C,CERAMIC 0.01UF-K/50V		D010103777160S	
C4038	nsp	C,CERAMIC 330PF-J/50V		D010331167160S	
C4039	00D9609010023	C,ELECT 0.47UF-M/50V		D040R47087050S	
C4040-4043	00D9630224503	C,ELECT 22UF-M/50V		D040220087060S	
C4044	nsp	C,CERAMIC 330PF-J/50V		D010331167160S	
C4045	nsp	C,CERAMIC 0.01UF-K/50V		D010103777160S	
C4046	nsp	C,CERAMIC 330PF-J/50V		D010331167160S	
C4047	00D9609010023	C,ELECT 0.47UF-M/50V		D040R47087050S	
C4048-4051	00D9630224503	C,ELECT 22UF-M/50V		D040220087060S	
C4052	nsp	C,CERAMIC 330PF-J/50V		D010331167160S	
C4053	00D9609010023	C,ELECT 0.47UF-M/50V		D040R47087050S	
C4054	nsp	C,CERAMIC 0.01UF-K/50V		D010103777160S	
C4055	00D9630234205	C,ELECT 10UF-M/50V		D040100087070S	
C4056	nsp	C,CERAMIC 100PF-J/50V		D010101167160S	
C4057	nsp	C,CERAMIC 0.01UF-K/50V		D010103777160S	
C4058	nsp	C,CERAMIC 100PF-J/50V		D010101167160S	
C4059	00D9630234205	C,ELECT 10UF-M/50V		D040100087070S	
C4129	00D9630234205	C,ELECT 10UF-M/50V	N1B,N1SG,K1B	D040100087070S	
C4130	nsp	C,FILM 0.0082UF	N1B,N1SG	D02082206C060S	
C4131	nsp	C,FILM 0.0047UF	N1B,N1SG	D02047206C060S	
C4134	00D9630234205	C,ELECT 10UF-M/50V	N1B,N1SG,K1B	D040100087070S	
C4135	nsp	C,FILM 0.0082UF	N1B,N1SG	D02082206C060S	
C4136	nsp	C,FILM 0.0047UF	N1B,N1SG	D02047206C060S	
C4143-4145	nsp	C,CERAMIC 100PF-J/50V	N1B,N1SG,K1B	D010101167160S	
C4146	nsp	C,CERAMIC 33PF-J/50V	N1B,N1SG,K1B	D010330167160S	
C4147,4148	nsp	C,CERAMIC 100PF-J/50V	N1B,N1SG,K1B	D010101167160S	
C4149	00D9630234205	C,ELECT 10UF-M/50V	N1B,N1SG,K1B	D040100087070S	
C4150	nsp	C,CERAMIC 4700PF-K/50V	N1B,N1SG,K1B	D011472777160S	

Ref. No.	Part No.	Part Name	Remarks	Q'ty	New
<b>OTHERS PARTS GROUP</b>					
CN3000	nsp	CN,WAFER 33P C125Z2		L109012523310S	
CN3001	nsp	CN,WIRE 13P 20010HS-13		L002221132620S	
CP4000	nsp	CN,WAFER 25P C125Z1-25		L109012512510S	
CP4003	963183011320S	TUNER,FM/AM KST-MT104MV1-2	K1B	E903104100110S	
CP4003	963183011300S	TUNER,FM/AM KST-MT004MV1-2	N1B,N1SG	E903004100110S	
JK3001-3003	00D9630132103	TER,RCA 4PIN RCA-405B-04		G602405B0400YS	
JK3004	00D9630387505	TER,RCA 4PIN RCA-405B-55		G602405B5500YS	
JK3005	00D9630132103	TER,RCA 4PIN RCA-405B-04		G602405B0400YS	
JK4001,4002	90M-YT004640R	TER,RCA 2PIN RCA-207AE-02		G601207AE020YS	
JK4003	00D9630387505	TER,RCA 4PIN RCA-405B-55		G602405B5500YS	
JK4004	00D9630132103	TER,RCA 4PIN RCA-405B-04		G602405B0400YS	
JK4005	00D9630146005	TER,RCA 1PIN		G600107A0000YS	
L4000	nsp	FILTER, MPX 75J-207CX	N1B,N1SG	E401010020020S	
L4001	nsp	COIL,BEAD CBW160808U121T	N1B,N1SG,K1B	D340160811210S	
L4002	nsp	FILTER, MPX 75J-207CX	N1B,N1SG	E401010020020S	
CX3000	nsp	CN,WAFER 19P C125Z2-19		L109012521910S	
CX3001	nsp	CN,WAFER 13P C125Z2-13		L109012521310S	
CX3002	nsp	CN,WAFER 17P C125Z2-17		L109012521710S	
CX3003	nsp	CN,WAFER 15P C125Z2-15		L109012521510S	
CX4000	nsp	CN,WAFER 27P C125Z1-27		L109012512710S	
CX4001	nsp	CN,WAFER 17P C125Z1-17		L109012511710S	
CX4002	nsp	CN,WAFER 15P C125Z1-15		L109012511510S	
CX4003	nsp	CN.FPC 19P TWG-P19P-A1		L131019000010S	

## PCB HDMI ASS'Y

	Ref. No.	Part No.	Part Name	Remarks		Q'ty	New
<b>SEMICONDUCTORS GROUP</b>							
	U1001	234810018506S	IC,LOGIC TC74VHC4052AFT	<b>NOTE :</b> When update Firmware, please confirm a last version in SDI. Use the service board after updating it.	J040744052080S		
	U1002	236810057606S	IC,LOGIC ADV3002BSTZ		J040300205510S		
	U1100	nsp	IC ADV7840		J040784005510S		
	U1101	nsp	IC PQ018ENA1ZPH		J126018010030S		
	U1600	963142010720S	CERAMIC CHIP 48MHz SMD2520		E85548R000020S		
	U1601	nsp	IC,LOGIC XC3S400A-4FGG320C		J040340043230S		
	U1602	246810010604D	IC IS42S32200E-6TL		J001423220040S		
	U1603	963248012500S	IC,ROM,OSD,M25P40-VMN6PB,SR6005		J005254005510S		*
	U1604	00MHC007805KZ	IC TC74VHCT125AFT		J040741255580S		
	U1605	00MHC007805KZ	IC TC74VHCT125AFT		J040741255580S		
	U1606	00MHC007805KZ	IC TC74VHCT125AFT	J040741255580S			
	U1607	231810071508S	IC PQ012ENB1ZPH	J126012010040S			
	U1800	00D2623436907	IC,LOGIC TC74VHC244FT	J040742445530S			
	U1801	963239010410S	IC ADV7511BSTZ-225	J040751100010S			
	U2000	nsp	IC PQ018ENA1ZPH	J126018010030S			
	U2001	nsp	IC,LOGIC ADV7392	J045739200010S			
	U2002	231310009508S	IC PQ033DNA1ZPH	J126033010010S			
	U2200	nsp	IC ABT2015	J080201500020S			
	U2201	00D2622557900	IC SN74LV14APWR	J040741400180S			
	U2500	nsp	IC K4T51163QI-HCE7	J001451163270S			
	U2501	nsp	IC K4T51163QI-HCE7	J001451163270S			
	U2800	00D9630237503	MODULE JSR1165-C	E100116500040S			
	U2801	00D9630237503	MODULE JSR1165-C	E100116500040S			
	U2802	00D9630113009	MODULE JST1165	E100116500030S			
	U2803	00D2623077900	IC TC74VHCU04FT	J040740405580S			
	U2805	236810062608S	IC LC89058W-E	J046890580020S			
	U3000	00D2623590005	IC A.PLD,EPM240T100C5N	J003240105510S		*	
	U3200	nsp	IC ADSP21367KSWZ2A1181	J080213675520S			
	U3201	246810048609S	IC W9864G2IH-6	J001986460060S			
	U3202	963248012190M	IC MEMORY FLASH for DSP (EN29LV160BB-70TIP)	J005291600050S			
	U3802	236810086505S	IC AK5358BET-E2	J043535805520S			
	U3803	236810073509S	IC AK4358VQ-L	J042435800010S			
	U3804	00D2631289900	IC AZ4580M	J121458000020S			
	U3805	00D2631289900	IC AZ4580M	J121458000020S			
	U3806	00D2631289900	IC AZ4580M	J121458000020S			
	U3807	00D2631289900	IC AZ4580M	J121458000020S			
	U4400	963248012200M	IC,MEMORY FLASH for USB (EN29LV160BT-70TIP)	J005291600070S			
	U4401	963244012410S	IC IS42S16400F-6TL	J001421640060S			
	U4402	nsp	IC MFI341S2164	J044341216410S			
	U4403	963239008830S	IC TCC8600 32BIT	J085860000010S			
	U4404	236810070500S	IC AK4424ET-E2 TSSOP16	J042442405520S			
	U4405	00D2790055907	SW,POLY MICROSMD175F	G300017500010S			
	U4600	231810069505S	IC AOZ1021AI	J048102100010S			
	U4601	nsp	IC EX3AV	J048030030010S			
	U4602	nsp	IC EX3AV	J048030030010S			
	U4604	nsp	IC EX3AV	J048030030010S			
	U4605	nsp	IC EX3AV	J048030030010S			
	U4606	231310009508S	IC PQ033DNA1ZPH	J126033010010S			
	U4607	231310009508S	IC PQ033DNA1ZPH	J126033010010S			

Ref. No.	Part No.	Part Name	Remarks	Q'ty	New
U4608	234810015507S	IC BU4248F		J126424800010S	
U5100	00MHC007805KZ	IC TC74VHCT125AFT		J040741255580S	
U5101	963248012480S	IC,ROM(MAIN EX),EN29LV160BB-70TIP		J005291600050S	*
U5104	234810014504S	IC MC14094BDTR2G		J040140940020S	
U5105	00D2623410907	IC TC74VHCT08AFT	U1B,N1B,N1SG	J040740800090S	
U5106	234810014504S	IC MC14094BDTR2G		J040140940020S	
U5107	234810014504S	IC MC14094BDTR2G		J040140940020S	
U5108	00D2623444902	IC TC74VHC08FT	U1B,N1B,N1SG	J040740800280S	
U5109	234810014504S	IC MC14094BDTR2G		J040140940020S	
U5300	963262012150M	MODULE REMOCON R94EV1A		E940941003610S	
U5301	963243012470S	IC,MAIN(NORM),R5F64169DFD,SR6005		J020564165510S	*
U5302	246810026500S	IC R1EX24256ASAS0A		J000242565550S	
U5500	963243012490S	IC,CPU SUB,R5F3650KNFB,SR6005		J020536505540S	*
Q1001-1003	00D9630120801	TR 2SC KRC102S (NB)	<b>NOTE :</b> When update Firmware, please confirm a last version in SDI. Use the service board after updating it.	J522010200210S	
Q1004-1009	00D9600285006	TR KRC104S (ND)		J522104S00210S	
Q1100-1102	00D9630120801	TR 2SC KRC102S (NB)		J522010200210S	
Q1103-1106	00D9600285006	TR KRC104S (ND)		J522104S00210S	
Q1600	00D9600285006	TR KRC104S (ND)		J522104S00210S	
Q1601	00D9630120801	TR 2SC KRC102S (NB)		J522010200210S	
Q1800	00D9630120704	TR KRA102S(PB)		J520010200210S	
Q1801	00D9630120801	TR 2SC KRC102S (NB)		J522010200210S	
Q2000	00D9600285006	TR KRC104S (ND)		J522104S00210S	
Q2001	00D2750110905	SEMI HN1K02FU		J543102000020S	
Q2200	00D2750110905	SEMI HN1K02FU		J543102000020S	
Q2201	00D9600285006	TR KRC104S (ND)		J522104S00210S	
Q3200	00D9630120801	TR 2SC KRC102S (NB)		J522010200210S	
Q3201	00D9630120704	TR KRA102S(PB)		J520010200210S	
Q4401,4402	00D9630120801	TR 2SC KRC102S (NB)		J522010200210S	
Q4403	963219004200S	CHIP FDC608PZ P-CH		J543608000010S	
Q4404	00D9630120704	TR KRA102S(PB)		J520010200210S	
Q4600	00D9630120801	TR 2SC KRC102S (NB)		J522010200210S	
Q4601	00D9600285006	TR KRC104S (ND)		J522104S00210S	
Q4602	00D9630120801	TR 2SC KRC102S (NB)		J522010200210S	
Q4603	00D9600285006	TR KRC104S (ND)		J522104S00210S	
Q4612-4619	00D9630121402	TR KRA104S		J520010400210S	
Q4620	00D9630120801	TR 2SC KRC102S (NB)		J522010200210S	
Q4621-4628	963219004200S	CHIP FDC608PZ P-CH		J543608000010S	
Q4629-4631	00D2710326904	TR 2SA 2SA1954		J520195405510S	
Q4632	00MHZ2000921Y	CHIP DAN202U 1.2V		K005020200200S	
Q4633,4634	00D2710326904	TR 2SA 2SA1954		J520195405510S	
Q4635,4636	00D9630120801	TR 2SC KRC102S (NB)		J522010200210S	
Q4638,4639	00D9630120801	TR 2SC KRC102S (NB)		J522010200210S	
Q4640	00D9630328302	TR 2SC KTC3875G(ALG)		J5223875G0210S	
Q4643	00D9630120801	TR 2SC KRC102S (NB)		J522010200210S	
Q4644	00D9600285006	TR KRC104S (ND)		J522104S00210S	
Q4645	00D9630120801	TR 2SC KRC102S (NB)		J522010200210S	
Q4646	00D9600285006	TR KRC104S (ND)		J522104S00210S	
Q4647	00D2710326904	TR 2SA 2SA1954		J520195405510S	
Q4648	00D9630120801	TR 2SC KRC102S (NB)		J522010200210S	
Q5100	00D9630120801	TR 2SC KRC102S (NB)		J522010200210S	
Q5101	00D2710326904	TR 2SA 2SA1954		J520195405510S	

Ref. No.	Part No.	Part Name	Remarks	Q'ty	New
Q5102	00D9630120801	TR 2SC KRC102S (NB)		J522010200210S	
Q5103	963219010750S	TR 2SA KTA1504G		J5201504G0210S	
Q5104,5105	00D9630328302	TR 2SC KTC3875G(ALG)		J5223875G0210S	
Q5106	963219010750S	TR 2SA KTA1504G		J5201504G0210S	
Q5107-5111	00D9630328302	TR 2SC KTC3875G(ALG)		J5223875G0210S	
Q5112-5115	00D9630120801	TR 2SC KRC102S (NB)		J522010200210S	
Q5303-5305	00D9630120801	TR 2SC KRC102S (NB)		J522010200210S	
Q5308	00D9630120704	TR KRA102S(PB)		J520010200210S	
Q5309	00D9630120801	TR 2SC KRC102S (NB)		J522010200210S	
Q5310-5313	00D9630121402	TR KRA104S		J520010400210S	
Q5314,5315	00D9630120801	TR 2SC KRC102S (NB)		J522010200210S	
Q5500	00D9630328302	TR 2SC KTC3875G(ALG)		J5223875G0210S	
Q5501	00D9630120704	TR KRA102S(PB)		J520010200210S	
Q5502	963219002180S	TR 2SD2114KT146W		J5232114K0010S	
Q5503	00D9630120801	TR 2SC KRC102S (NB)		J522010200210S	
Q5504	00D9630328302	TR 2SC KTC3875G(ALG)		J5223875G0210S	
Q5505,5506	00D9630120801	TR 2SC KRC102S (NB)		J522010200210S	
D1001	00D9630328603	D,SCHOTTKY RB521S-30		K125521300010S	
D4600,4601	00D9630355401	D,SWITCHING KDS4148U		K005041480030S	
D5304	00D9630355401	D,SWITCHING KDS4148U		K005041480030S	
D5305	90M-HI200030R	LED,IR SIR -34ST3F 3PI 2.5MM		K505343000010S	
D5308	nsp	CHIP RES. 470K-J 1/16W-1608REEL		C20004746M160S	
D5311	00D9630355401	D,SWITCHING KDS4148U		K005041480030S	
D5500	00D9630355401	D,SWITCHING KDS4148U		K005041480030S	
<b>RESISTORS GROUP</b>					
R4900	nsp	R,CHIP 10K-J,1/16W	N1B,N1SG,K1B	C20001036M111S	
R4903	nsp	R,CHIP 10K-J,1/16W	U1B	C20001036M111S	
R4903	nsp	R,CHIP 4.7K-J,1/16W	N1B,N1SG,K1B	C20004726M101S	
R5111	nsp	R,CHIP 33-J,1/16W	N1B,N1SG	C20003306M101S	
R5112	nsp	R,CHIP 33-J,1/16W	U1B	C20003306M101S	
R5113,5114	nsp	R,CHIP 33-J,1/16W	U1B,N1B,N1SG	C20003306M101S	
R5332	nsp	R,CHIP 10K-J,1/16W	U1B,K1B	C20001036M160S	
R5340	nsp	R,CHIP 10K-J,1/16W	N1B,N1SG,K1B	C20001036M160S	
<b>CAPACITORS GROUP</b>					
C1003-1008	nsp	C,CERAMIC 0.1UF-K/50V		D011104177101S	
C1009	nsp	C,CERAMIC 4.7UF-K/6.3V		D011475571160S	
C1015	nsp	C,CERAMIC 1000PF-K/50V		D011102177101S	
C1100-1106	nsp	C,CERAMIC 0.1UF-K/50V		D011104177101S	
C1107	nsp	C,CERAMIC 0.01UF-K/16V		D011103177101S	
C1108,1109	nsp	C,CERAMIC 0.1UF-K/50V		D011104177101S	
C1110	nsp	C,CERAMIC 12PF-J/50V		D011120167101S	
C1111-1113	nsp	C,CERAMIC 0.1UF-K/50V		D011104177101S	
C1114	nsp	C,CERAMIC 12PF-J/50V		D011120167101S	
C1115,1116	nsp	C,CERAMIC 15PF-J/50V		D011150167101S	
C1117	nsp	C,CERAMIC 1000PF-K/50V		D011102177101S	
C1118	nsp	C,CERAMIC 4.7UF-K/6.3V		D011475571160S	
C1121-1124	nsp	C,CERAMIC 0.1UF-K/50V		D011104177101S	

	Ref. No.	Part No.	Part Name	Remarks		Q'ty	New
	C1125	nsp	C,CERAMIC 4.7UF-K/6.3V		D011475571160S		
	C1126	nsp	C,CERAMIC 0.1UF-K/50V		D011104177101S		
	C1128-1132	nsp	C,CERAMIC 0.1UF-K/50V		D011104177101S		
	C1133	nsp	C,CERAMIC 4.7UF-K/6.3V		D011475571160S		
	C1134	nsp	C,CERAMIC 0.1UF-K/50V		D011104177101S		
	C1137	nsp	C,CERAMIC 0.1UF-K/50V		D011104177101S		
	C1139	nsp	C,CERAMIC 0.1UF-K/50V		D011104177101S		
	C1141-1143	nsp	C,CERAMIC 10UF-K/16V		D011106573200S		
	C1145	nsp	C,CERAMIC 0.1UF-K/50V		D011104177101S		
	C1156,1157	nsp	C,CERAMIC 0.1UF-K/50V		D011104177101S		
	C1159	nsp	C,CERAMIC 10UF-K/16V		D011106573200S		
	C1160	nsp	C,CERAMIC 0.1UF-K/50V		D011104177101S		
	C1162	nsp	C,CERAMIC0.082UF-Z/50V		D011823597160S		
	C1163	nsp	C,CERAMIC0.01UF-K/50V		D011103777160S		
	C1164	nsp	C,CERAMIC 0.82UF-K/10V		D011824772162S		
	C1165	nsp	C,CERAMIC X7R0.039UF-K/50V		D011393707160S		
	C1166,1167	nsp	C,CERAMIC 0.01UF-K/16V		D011103177101S		
	C1168	nsp	C,CERAMIC 4.7UF-K/6.3V		D011475571160S		
	C1171	nsp	C,CERAMIC 0.1UF-K/50V		D011104177101S		
	C1172	nsp	C,CERAMIC 4.7UF-K/6.3V		D011475571160S		
	C1173,1174	nsp	C,CERAMIC 0.1UF-K/50V		D011104177101S		
	C1175	nsp	C,CERAMIC 10UF-K/16V		D011106573200S		
	C1176-1180	nsp	C,CERAMIC 0.1UF-K/50V		D011104177101S		
	C1182-1187	nsp	C,CERAMIC 0.1UF-K/50V		D011104177101S		
	C1188	nsp	C,CERAMIC 4.7UF-K/6.3V		D011475571160S		
	C1190	nsp	C,CERAMIC 0.1UF-K/50V		D011104177101S		
	C1193,1194	nsp	C,CERAMIC 0.1UF-K/50V		D011104177101S		
	C1196,1197	nsp	C,CERAMIC 0.1UF-K/50V		D011104177101S		
	C1200	nsp	C,CERAMIC 0.1UF-K/50V		D011104177101S		
	C1201	nsp	C,CERAMIC 4.7UF-K/6.3V		D011475571160S		
	C1204	nsp	C,CERAMIC 0.1UF-K/50V		D011104177101S		
	C1207	nsp	C,CERAMIC 0.1UF-K/50V		D011104177101S		
	C1208	nsp	C,CERAMIC 4.7UF-K/6.3V		D011475571160S		
	C1209	nsp	C,CERAMIC 0.1UF-K/50V		D011104177101S		
	C1213,1214	nsp	C,CERAMIC 0.1UF-K/50V		D011104177101S		
	C1217,1218	nsp	C,CERAMIC 0.1UF-K/50V		D011104177101S		
	C1219	nsp	C,CERAMIC 4.7UF-K/6.3V		D011475571160S		
	C1222	nsp	C,CERAMIC 0.1UF-K/50V		D011104177101S		
	C1237	nsp	C,CERAMIC 1000PF-K/50V		D011102177101S		
	C1238	nsp	C,CERAMIC 4.7UF-K/6.3V		D011475571160S		
	C1239	963134011230S	C, ELECT 330UF-M/6.3V		D041331081020S		
	C1600	nsp	C,CERAMIC 4.7UF-K/6.3V		D011475571160S		
	C1602	nsp	C,CERAMIC 0.1UF-K/50V		D011104177101S		
	C1607-1614	nsp	C,CERAMIC 0.1UF-K/50V		D011104177101S		
	C1615	nsp	C,CERAMIC 1000PF-K/50V		D011102177101S		
	C1616	nsp	C,CERAMIC 4.7UF-K/6.3V		D011475571160S		
	C1619-1631	nsp	C,CERAMIC 0.1UF-K/50V		D011104177101S		
	C1633	nsp	C,CERAMIC 0.1UF-K/50V		D011104177101S		
	C1635-1646	nsp	C,CERAMIC 0.1UF-K/50V		D011104177101S		
	C1650,1651	nsp	C,CERAMIC 0.1UF-K/50V		D011104177101S		
	C1653	nsp	C,CERAMIC 4.7UF-K/6.3V		D011475571160S		
	C1658	nsp	C,CERAMIC 4.7UF-K/6.3V		D011475571160S		



Ref. No.	Part No.	Part Name	Remarks	Q'ty	New
C1662	nsp	C,CERAMIC 4.7UF-K/6.3V		D011475571160S	
C1664	nsp	C,CERAMIC 4.7UF-K/6.3V		D011475571160S	
C1665-1667	nsp	C,CERAMIC 0.1UF-K/50V		D011104177101S	
C1669	nsp	C,CERAMIC 0.1UF-K/50V		D011104177101S	
C1670	nsp	C,CERAMIC 4.7UF-K/6.3V		D011475571160S	
C1800,1801	nsp	C,CERAMIC 0.1UF-K/50V		D011104177101S	
C1802	nsp	C,CERAMIC 10UF-K/16V		D011106573200S	
C1805-1808	nsp	C,CERAMIC 0.1UF-K/50V		D011104177101S	
C1809	nsp	C,CERAMIC 10UF-K/16V		D011106573200S	
C1812-1815	nsp	C,CERAMIC 0.1UF-K/50V		D011104177101S	
C1816	nsp	C,CERAMIC 4.7UF-K/6.3V		D011475571160S	
C1819,1820	nsp	C,CERAMIC 0.1UF-K/50V		D011104177101S	
C1821	nsp	C,CERAMIC 10UF-K/16V		D011106573200S	
C1834-1836	nsp	C,CERAMIC 1UF-K/10V		D011105772161S	
C1839	963134011230S	C, ELECT 330UF-M/6.3V		D041331081020S	
C2000	nsp	C,CERAMIC 0.1UF-K/50V		D011104177101S	
C2001	nsp	C,CERAMIC 4.7UF-K/6.3V		D011475571160S	
C2004-2007	nsp	C,CERAMIC 0.1UF-K/50V		D011104177101S	
C2010	nsp	C,CERAMIC 1000PF-K/50V		D011102177101S	
C2011	nsp	C,CERAMIC 4.7UF-K/6.3V		D011475571160S	
C2012	nsp	C,CERAMIC 2200PF-K/50V		D011222177101S	
C2013,2014	nsp	C,CERAMIC 0.1UF-K/50V		D011104177101S	
C2016	nsp	C,CERAMIC 0.012UF-K/50V		D011123177161S	
C2018	nsp	C,CERAMIC 0.1UF-K/50V		D011104177101S	
C2020	nsp	C,CERAMIC 0.15uF-K/10V		D011154172160S	
C2200	nsp	C,CERAMIC 5PF-C/50V		D011050107101S	
C2201	nsp	C,CERAMIC 4.7UF-K/6.3V		D011475571160S	
C2204	nsp	C,CERAMIC 0.1UF-K/50V		D011104177101S	
C2206	nsp	C,CERAMIC 0.1UF-K/50V		D011104177101S	
C2208	nsp	C,CERAMIC 0.1UF-K/50V		D011104177101S	
C2210	nsp	C,CERAMIC 0.1UF-K/50V		D011104177101S	
C2212	nsp	C,CERAMIC 0.1UF-K/50V		D011104177101S	
C2214	nsp	C,CERAMIC 0.1UF-K/50V		D011104177101S	
C2216	nsp	C,CERAMIC 0.1UF-K/50V		D011104177101S	
C2218	nsp	C,CERAMIC 0.1UF-K/50V		D011104177101S	
C2220	nsp	C,CERAMIC 0.1UF-K/50V		D011104177101S	
C2221	nsp	C,CERAMIC 4.7UF-K/6.3V		D011475571160S	
C2222	nsp	C,CERAMIC 0.1UF-K/50V		D011104177101S	
C2224	nsp	C,CERAMIC 0.1UF-K/50V		D011104177101S	
C2227	nsp	C,CERAMIC 0.1UF-K/50V		D011104177101S	
C2237	nsp	C,CERAMIC 4.7UF-K/6.3V		D011475571160S	
C2241-2247	nsp	C,CERAMIC 0.1UF-K/50V		D011104177101S	
C2254-2259	nsp	C,CERAMIC 0.1UF-K/50V		D011104177101S	
C2260	nsp	C,CERAMIC 4.7UF-K/6.3V		D011475571160S	
C2263	nsp	C,CERAMIC 0.1UF-K/50V		D011104177101S	
C2265-2270	nsp	C,CERAMIC 0.1UF-K/50V		D011104177101S	
C2279	nsp	C,CERAMIC 0.1UF-K/50V		D011104177101S	
C2280	nsp	C,CERAMIC 4.7UF-K/6.3V		D011475571160S	
C2282	nsp	C,CERAMIC 0.1UF-K/50V		D011104177101S	
C2283	nsp	C,CERAMIC 4.7UF-K/6.3V		D011475571160S	
C2285	nsp	C,CERAMIC 0.1UF-K/50V		D011104177101S	
C2286	nsp	C,CERAMIC 4.7UF-K/6.3V		D011475571160S	

	Ref. No.	Part No.	Part Name	Remarks		Q'ty	New
	C2287,2288	nsp	C,CERAMIC 8pF-J/50V		D010080167100S		
	C2290	nsp	C,CERAMIC 0.1UF-K/50V		D011104177101S		
	C2500-2502	nsp	C,CERAMIC 0.1UF-K/50V		D011104177101S		
	C2503	nsp	C,CERAMIC 4.7UF-K/6.3V		D011475571160S		
	C2505	nsp	C,CERAMIC 0.1UF-K/50V		D011104177101S		
	C2506	nsp	C,CERAMIC 4.7UF-K/6.3V		D011475571160S		
	C2508-2516	nsp	C,CERAMIC 0.1UF-K/50V		D011104177101S		
	C2524-2526	nsp	C,CERAMIC 0.1UF-K/50V		D011104177101S		
	C2527	nsp	C,CERAMIC 4.7UF-K/6.3V		D011475571160S		
	C2529	nsp	C,CERAMIC 0.1UF-K/50V		D011104177101S		
	C2530	nsp	C,CERAMIC 4.7UF-K/6.3V		D011475571160S		
	C2532-2540	nsp	C,CERAMIC 0.1UF-K/50V		D011104177101S		
	C2800-2802	nsp	C,CERAMIC 0.1UF-K/50V		D011104177101S		
	C2805-2809	nsp	C,CERAMIC 0.01UF-K/16V		D011103177101S		
	C2810	nsp	C,CERAMIC 4.7UF-K/6.3V		D011475571160S		
	C2811-2813	nsp	C,CERAMIC 0.1UF-K/50V		D011104177101S		
	C2816	nsp	C,CERAMIC 0.1UF-K/50V		D011104177101S		
	C2819,2820	nsp	C,CERAMIC 0.1UF-K/50V		D011104177101S		
	C2825,2826	nsp	C,CERAMIC10PF-J/50V		D011100167101S		
	C2827,2828	nsp	C,CERAMIC 0.1UF-K/50V		D011104177101S		
	C2833	nsp	C,CERAMIC 4.7UF-K/6.3V		D011475571160S		
	C2835	nsp	C,CERAMIC 1000PF-K/50V		D011102177101S		
	C2836	nsp	C,CERAMIC 0.1UF-K/50V		D011104177101S		
	C2841	nsp	C,CERAMIC 0.022UF-Z/50V		D011223597160S		
	C2844,2845	nsp	C,CERAMIC 0.1UF-K/50V		D011104177101S		
	C3000-3005	nsp	C,CERAMIC 0.1UF-K/50V		D011104177101S		
	C3006	nsp	C,CERAMIC 4.7UF-K/6.3V		D011475571160S		
	C3007	nsp	C,CERAMIC 1000PF-K/50V		D011102177101S		
	C3008,3009	nsp	C,CERAMIC 100PF-J/50V		D011101167101S		
	C3010,3011	nsp	C,CERAMIC 0.1UF-K/50V		D011104177101S		
	C3014	nsp	C,CERAMIC 100PF-J/50V		D011101167101S		
	C3200-3209	nsp	C,CERAMIC 0.1UF-K/50V		D011104177101S		
	C3218-3240	nsp	C,CERAMIC 0.1UF-K/50V		D011104177101S		
	C3241	nsp	C,CERAMIC 4.7UF-K/6.3V		D011475571160S		
	C3242	nsp	C,CERAMIC 0.1UF-K/50V		D011104177101S		
	C3243	nsp	C,CERAMIC 4.7UF-K/6.3V		D011475571160S		
	C3244	nsp	C,CERAMIC 0.1UF-K/50V		D011104177101S		
	C3247-3252	nsp	C,CERAMIC 0.1UF-K/50V		D011104177101S		
	C3253	nsp	C,CERAMIC 4.7UF-K/6.3V		D011475571160S		
	C3254-3259	nsp	C,CERAMIC 0.1UF-K/50V		D011104177101S		
	C3260-3262	nsp	C,CERAMIC 4.7UF-K/6.3V		D011475571160S		
	C3264	nsp	C,CERAMIC 0.1UF-K/50V		D011104177101S		
	C3265,3266	nsp	C,CERAMIC 7PF-C/50V		D011070117101S		
	C3267-3280	nsp	C,CERAMIC 0.1UF-K/50V		D011104177101S		
	C3804	nsp	C,CERAMIC 0.1UF-K/50V		D011104177101S		
	C3814	nsp	C,CERAMIC 4.7UF-K/6.3V		D011475571160S		
	C3816	nsp	C,CERAMIC 1UF-K/10V		D011105772161S		
	C3817	nsp	C,CERAMIC 0.1UF-K/50V		D011104177101S		
	C3818	nsp	C,CERAMIC 4.7UF-K/6.3V		D011475571160S		
	C3819	nsp	C,CERAMIC 1UF-K/10V		D011105772161S		
	C3820,3821	nsp	C,CERAMIC 0.1UF-K/50V		D011104177101S		
	C3822-3841	nsp	C,CERAMIC 1000PF-K/50V		D011102177101S		

Ref. No.	Part No.	Part Name	Remarks	Q'ty	New
C3842,3843	00D9630338606	C,ELECT 10UF-MVG/16V		D050100083470S	
C3844	nsp	C,CERAMIC 0.1UF-K/50V		D011104177101S	
C3845,3846	nsp	C,CERAMIC 4700PF-K/50V		D011472777160S	
C3847	nsp	C,CERAMIC 0.1UF-K/50V		D011104177101S	
C3848	nsp	C,CERAMIC 4.7UF-K/6.3V		D011475571160S	
C3849	963134000450S	C,ELECT 100UF-MVG/16V		D050101083660S	
C3850,3851	nsp	C,CERAMIC X7R3900PF-K/50V		D011392777160S	
C3852	nsp	C,CERAMIC X7R2700PF-K/50V		D011272777160S	
C3853-3855	nsp	C,CERAMIC X7R3900PF-K/50V		D011392777160S	
C3856,3857	nsp	C,CERAMIC X7R2700PF-K/50V		D011272777160S	
C3858-3873	nsp	C,CERAMIC 470PF-J/50V		D010471167160S	
C3874,3875	963134000450S	C,ELECT 100UF-MVG/16V		D050101083660S	
C3878	nsp	C,CERAMIC 1000PF-K/50V		D011102177101S	
C4401	nsp	C,CERAMIC 1000PF-K/50V		D011102177101S	
C4402-4410	nsp	C,CERAMIC 0.1UF-K/50V		D011104177101S	
C4411	nsp	C,CERAMIC 1000PF-K/50V		D011102177101S	
C4412	nsp	C,CERAMIC 0.1UF-K/50V		D011104177101S	
C4414	nsp	C,CERAMIC 4.7UF-K/6.3V		D011475571160S	
C4420-4422	nsp	C,CERAMIC 0.1UF-K/50V		D011104177101S	
C4427,4428	nsp	C,CERAMIC 100PF-J/50V		D011101167101S	
C4429-4433	nsp	C,CERAMIC 0.1UF-K/50V		D011104177101S	
C4434	nsp	C,CERAMIC 1000PF-K/50V		D011102177101S	
C4435	nsp	C,CERAMIC 390PF-K/50V		D011391177101S	
C4436-4438	nsp	C,CERAMIC 0.1UF-K/50V		D011104177101S	
C4439	nsp	C,CERAMIC 1200PF-K/50V		D011122177101S	
C4440-4442	nsp	C,CERAMIC 0.1UF-K/50V		D011104177101S	
C4443	nsp	C,CERAMIC 4.7UF-K/6.3V		D011475571160S	
C4447-4449	nsp	C,CERAMIC 0.1UF-K/50V		D011104177101S	
C4453,4454	nsp	C,CERAMIC 18PF-J/50V		D011180167101S	
C4455	nsp	C,CERAMIC 1UF-K/10V		D011105772161S	
C4457	nsp	C,CERAMIC 0.1UF-K/50V		D011104177101S	
C4458	nsp	C,CERAMIC 1UF-K/10V		D011105772161S	
C4459-4462	nsp	C,CERAMIC 4.7UF-K/6.3V		D011475571160S	
C4463,4464	nsp	C,CERAMIC 2200PF-K/50V		D011222777160S	
C4465	nsp	C,CERAMIC 0.1UF-K/50V		D011104177101S	
C4468,4469	nsp	C,CERAMIC 100PF-J/50V		D011101167101S	
C4600,4601	nsp	C,CERAMIC 0.1UF-K/50V		D011104177101S	
C4603,4604	nsp	C,CERAMIC 0.1UF-K/50V		D011104177101S	
C4610	nsp	C,CERAMIC 0.1UF-K/50V		D011104177101S	
C4618	nsp	C,CERAMIC 10UF-K/16V		D011106573200S	
C4622-4624	nsp	C,CERAMIC 10UF-K/16V		D011106573200S	
C4626,4627	nsp	C,CERAMIC 10UF-K/16V		D011106573200S	
C4628,4629	nsp	C,CERAMIC 0.01UF-K/16V		D011103177101S	
C4631,4632	nsp	C,CERAMIC 0.01UF-K/16V		D011103177101S	
C4633,4634	nsp	C,CERAMIC 0.1UF-K/50V		D011104177101S	
C4636,4637	nsp	C,CERAMIC 0.1UF-K/50V		D011104177101S	
C4638,4639	nsp	C,CERAMIC 10UF-K/16V		D011106573200S	
C4641-4644	nsp	C,CERAMIC 10UF-K/16V		D011106573200S	
C4646,4647	nsp	C,CERAMIC 10UF-K/16V		D011106573200S	
C4648	nsp	C,CERAMIC 2200PF-K/50V		D011222777160S	
C4649,4650	nsp	C,CERAMIC 10UF-K/16V		D011106573200S	
C4651,4652	nsp	C,CERAMIC 15PF-J/50V		D011150167101S	

	Ref. No.	Part No.	Part Name	Remarks		Q'ty	New
	C4654,4655	nsp	C,CERAMIC 15PF-J/50V		D011150167101S		
	C4656	nsp	C,CERAMIC 10UF-K/16V		D011106573200S		
	C4668-4675	nsp	C,CERAMIC 0.01UF-K/16V		D011103177101S		
	C4676-4684	nsp	C,CERAMIC 0.1UF-K/50V		D011104177101S		
	C4717,4718	nsp	C,CERAMIC 1UF-K/10V		D011105772161S		
	C4727,4728	nsp	C,CERAMIC 1UF-K/10V		D011105772161S		
	C4785	nsp	C,CERAMIC X7R0.015UF-K/50V		D011153777160S		
	C4791	00D9630325402	C,ELECT 470UF-MVG/6.3V		D050471081200S		
	C4792,4793	nsp	C,CERAMIC 0.1UF-K/50V		D011104177101S		
	C4795	nsp	C,CERAMIC 1UF-K/10V		D011105772161S		
	C4796,4797	nsp	C,CERAMIC 0.1UF-K/50V		D011104177101S		
	C4800	nsp	C,CERAMIC 0.1UF-K/50V		D011104177101S		
	C4803	nsp	C,CERAMIC 1000PF-K/50V		D011102177101S		
	C4914-4918	nsp	C,CERAMIC 0.1UF-K/50V		D011104177101S		
	C5101	nsp	C,CERAMIC 1000PF-K/50V		D011102177101S		
	C5115	nsp	C,CERAMIC 0.01UF-K/16V		D011103177101S		
	C5117-5120	nsp	C,CERAMIC 0.01UF-K/16V		D011103177101S		
	C5306	nsp	C,CERAMIC 4.7UF-K/6.3V		D011475571160S		
	C5308	nsp	C,CERAMIC 4.7UF-K/6.3V		D011475571160S		
	C5313	nsp	C,CERAMIC 4.7UF-K/6.3V		D011475571160S		
	C5319	nsp	C,CERAMIC 4.7UF-K/6.3V		D011475571160S		
	C5321,5322	nsp	C,CERAMIC10PF-J/50V		D011100167101S		
	C5502,5503	nsp	C,CERAMIC 10PF-J/50V		D010100167161S		
	C5506	nsp	C,CERAMIC 4.7UF-K/6.3V		D011475571160S		
	C5516	nsp	C,CERAMIC 220PF-K/50V		D011221177101S		
	C9064	nsp	C,CERAMIC 5PF-C/50V		D011050107101S		
	C9068	nsp	C,CERAMIC 5PF-C/50V		D011050107101S		
	OTHERS PARTS GROUP						
	L1100	nsp	COIL,BEAD CBW160808U121T		D340160811210S		
	L1101	nsp	COIL,BEAD BLM21PG221SN1		D340201212210S		
	L1600,1601	nsp	COIL,BEAD BLM21PG221SN1		D340201212210S		
	L1800-1802	nsp	COIL,CHIP FLC32C220K		D307322205520S		
	L1804	nsp	R,CHIP 0-J,1/8W		C200000061300S		
	L2200	nsp	COIL,CHIP FLC32C220K		D307322205520S		
	L2203-2205	nsp	COIL,CHIP FLC32C220K		D307322205520S		
	L2500,2501	nsp	COIL,CHIP FLC32C220K		D307322205520S		
	L4400-4402	nsp	COIL,BEAD BLM21PG221SN1		D340201212210S		
	L4403,4404	nsp	R,CHIP 0-J, 1/16W		C20000006M160S		
	L4405	nsp	R,THICK 0-J,1/10W		C200000060201S		
	L4600-4603	nsp	COIL,BEAD BLM21PG221SN1		D340201212210S		
	L4606-4611	nsp	COIL,BEAD BLM21PG221SN1		D340201212210S		
	L4612	nsp	COIL,INDUCTOR B82464Z4103M		D310824641030S		
	L4613,4614	nsp	COIL,BEAD BLM21PG221SN1		D340201212210S		
	L4625-4627	nsp	COIL,BEAD BLM21PG221SN1		D340201212210S		
	L4628	nsp	COIL,BEAD CBW160808U121T		D340160811210S		
	L4981	nsp	R,CHIP 0-J, 1/16W		C20000006M160S		
	L5040	nsp	R,THICK 0-J,1/10W		C200000060201S		
	X1102,1103	141810044504S	CRYSTAL CHIP FCX-04(28.63636MHz)		E80528R636380S		

Ref. No.	Part No.	Part Name	Remarks	Q'ty	New
X2201	141810045507S	CRYSTAL CHIP FCX-04(27MHz)		E80527R000080S	
X2801	141810046500S	CRYSTAL CHIP FCX-04(24.576MHz)		E80524R576080S	
X3201	141810047503S	CRYSTAL CHIP FCX-04(20.815MHz)		E80520R815080S	
X4401	963141010270S	CRYSTAL CHIP FCX-04C(12MHz)		E80512R000080S	
X5301	141810048506S	CRYSTAL CHIP FCX-04(16MHz)		E80516R000080S	
X5501	141810048506S	CRYSTAL CHIP FCX-04(16MHz)		E80516R000080S	
K1001-1003	644010108608S	HDMI CONNECTOR(YKF45-7074N)		L109100190450S	
K1100	644010108608S	HDMI CONNECTOR(YKF45-7074N)		L109100190450S	
K1101,1102	644010108608S	HDMI CONNECTOR(YKF45-7074N)		L109100190450S	
K2800	963646012340S	TER,RCA 2PIN 206A-07		G601206A0700YS	
K5302	nsp	JACK,D3.5 EARPHONE		G40130802000YS	
N1801	644010108608S	HDMI CONNECTOR(YKF45-7074N)		L109100190450S	
N3000	nsp	CN.FPC 7P 1.0-16-7PB-2		L130100160730S	
N4401	nsp	CN.WAFER 5P		L101200220510S	
N4610	nsp	CN.WAFER 5P SMW250-5P		L102050010040S	
N4905	nsp	CN.WAFER 5P		L101200220510S	
N4907	nsp	CN,WAFER 25P C125Z2-25		L109012522510S	
N4908	nsp	CN,WAFER 11P C125Z2-11		L109012521110S	
N4909	nsp	CN.FPC 40P 10022HS-40C		L130100220400S	
N4910	nsp	CN,WAFER 19P C125Z2-19		L109012521910S	
N4911	nsp	CN,WAFER 17P C125Z2-17		L109012521710S	
N4912	nsp	CN,WAFER 13P C125Z2-13		L109012521310S	
N4913	nsp	CN,WAFER 19P C125Z2-19		L109012521910S	
N4914	nsp	CN,WAFER 17P C125Z2-17		L109012521710S	
N4916	nsp	CN.WAFER 33P C125Z2		L109012523310S	
	nsp	SHIELD CASE t0.3 A4		3070210646000S	