

**Model:** SR6001, SR7001 SR8001

**Subject:** The thermal sensor is sometimes activated, which shuts down the unit putting the unit into standby.\*

\* Perform the following rework if no faulty point (defective output devices, DC offset, over voltage, over current, heat issue) is found that would activate the protection circuit and /or it still shows error message "CHECK POW5" on the FLD.

**Symptom:** The Heat Sensor is mounted on the PWB with a connector in order to detect a temperature rise with the Power Amp. When the connector has a loose connection, the protection circuit is activated, thereby causing a shut down.

**Solution:** If no faulty point is found that would activate the protection circuit and /or it still shows error message "CHECK POW5" on the FLD perform the following procedure.

Replace the sensor assembly and solder the lead wires directly to the PWB.



1. Detach the AMP PWB ASSY (POS NO. 38) from the Heat Sink and replace the Heat Sensor TH1 (CN81) with a new part (P/N 90M-HP000120R).

---

**CONFIDENTIALITY NOTICE:**

The information contained in this document is intended for the exclusive use by MARANTZ Authorized Service Centers and their employees. This document may contain information that is privileged, confidential and may be protected from disclosure under applicable laws and terms of the MARANTZ Service Agreement. Any distribution, disclosure, dissemination or copying of this document and the information it contains is prohibited. No responsibility will be accepted by MARANTZ for any damage, injury or loss resulting from the misuse of the information contained in this document.

2. Cut the white plastic connector (CN81) off the new Heat Sensor then strip ¼ inch (approx.) of insulation from the end of the lead and tin each end of the lead wire. (Fig. 1)

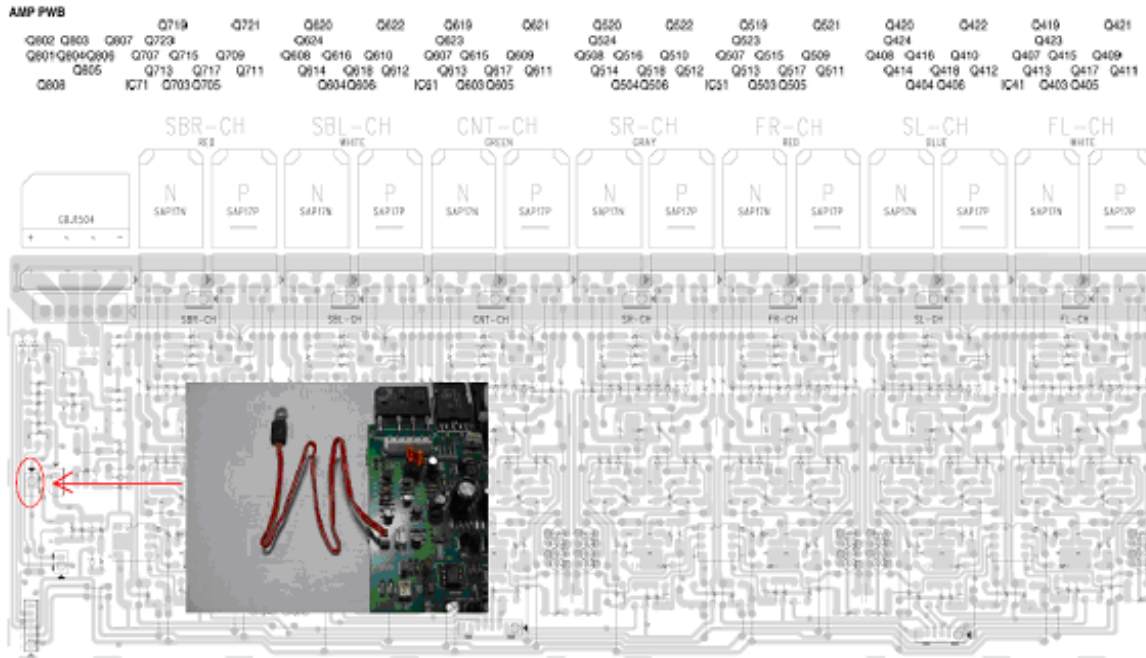

Fig.1

Fig.2



**CONFIDENTIALITY NOTICE:**

The information contained in this document is intended for the exclusive use by MARANTZ Authorized Service Centers and their employees. This document may contain information that is privileged, confidential and may be protected from disclosure under applicable laws and terms of the MARANTZ Service Agreement. Any distribution, disclosure, dissemination or copying of this document and the information it contains is prohibited. No responsibility will be accepted by MARANTZ for any damage, injury or loss resulting from the misuse of the information contained in this document.

3. Solder the stripped ends of the lead wires to resistors R811 and R812 as shown below.

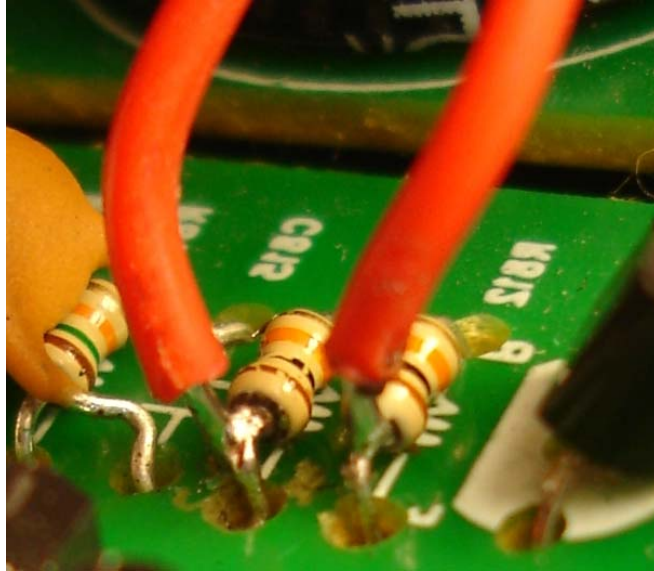

---

**CONFIDENTIALITY NOTICE:**

The information contained in this document is intended for the exclusive use by MARANTZ Authorized Service Centers and their employees. This document may contain information that is privileged, confidential and may be protected from disclosure under applicable laws and terms of the MARANTZ Service Agreement. Any distribution, disclosure, dissemination or copying of this document and the information it contains is prohibited. No responsibility will be accepted by MARANTZ for any damage, injury or loss resulting from the misuse of the information contained in this document.

**Note:** The Heat Sensor has no polarity however, be certain to connect the sensor to the side of each resistor that corresponds (electrically) to connector CN81's pins 1 & 2. Do not solder the leads to the side of resistors R811 and R812 that are closest to the base of transistor Q801. See Figure 3 for details.

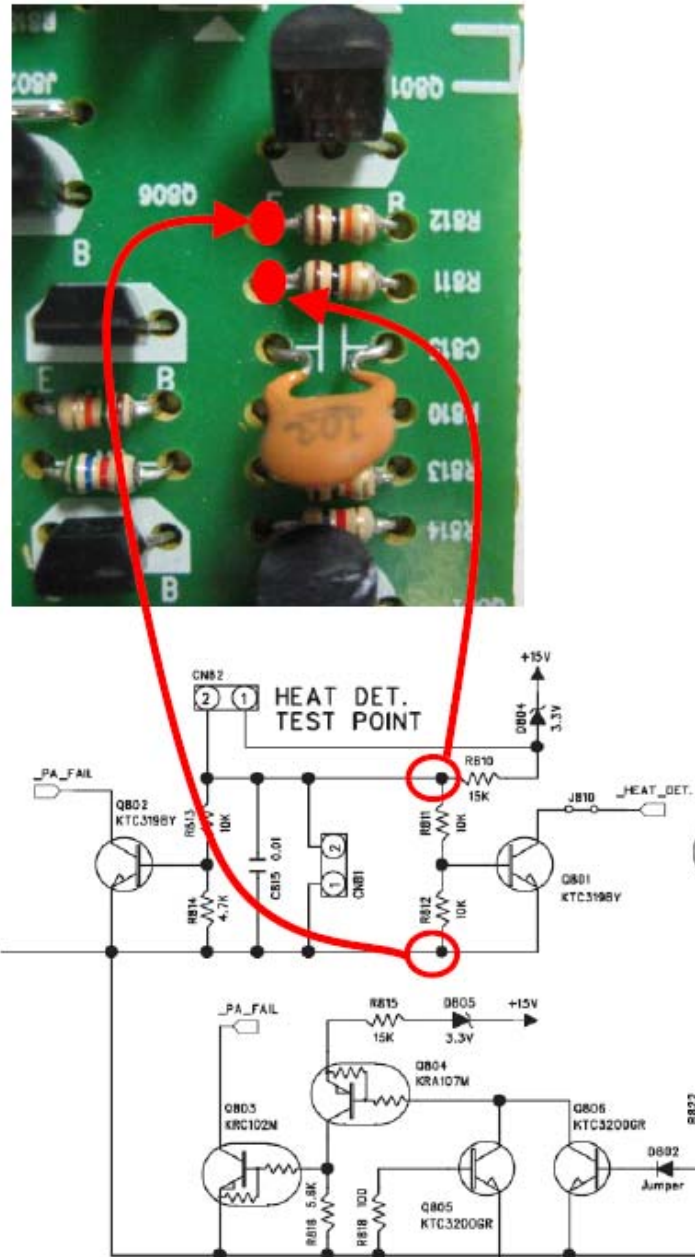

Fig. 3

**CONFIDENTIALITY NOTICE:**

The information contained in this document is intended for the exclusive use by MARANTZ Authorized Service Centers and their employees. This document may contain information that is privileged, confidential and may be protected from disclosure under applicable laws and terms of the MARANTZ Service Agreement. Any distribution, disclosure, dissemination or copying of this document and the information it contains is prohibited. No responsibility will be accepted by MARANTZ for any damage, injury or loss resulting from the misuse of the information contained in this document.

4. Fix the soldered wire ends to the resistors using Sony® bond SC608Z or Dow Corning® SE 9188 RTV high temperature RTV.



5. Mount the new Heat Sensor to the heat sink.

---

**CONFIDENTIALITY NOTICE:**

The information contained in this document is intended for the exclusive use by MARANTZ Authorized Service Centers and their employees. This document may contain information that is privileged, confidential and may be protected from disclosure under applicable laws and terms of the MARANTZ Service Agreement. Any distribution, disclosure, dissemination or copying of this document and the information it contains is prohibited. No responsibility will be accepted by MARANTZ for any damage, injury or loss resulting from the misuse of the information contained in this document.

After replacing the Heat Sensor use a felt tipped permanent marking pen to record the date the sensor was changed to the inside of the top cover (left side panel).

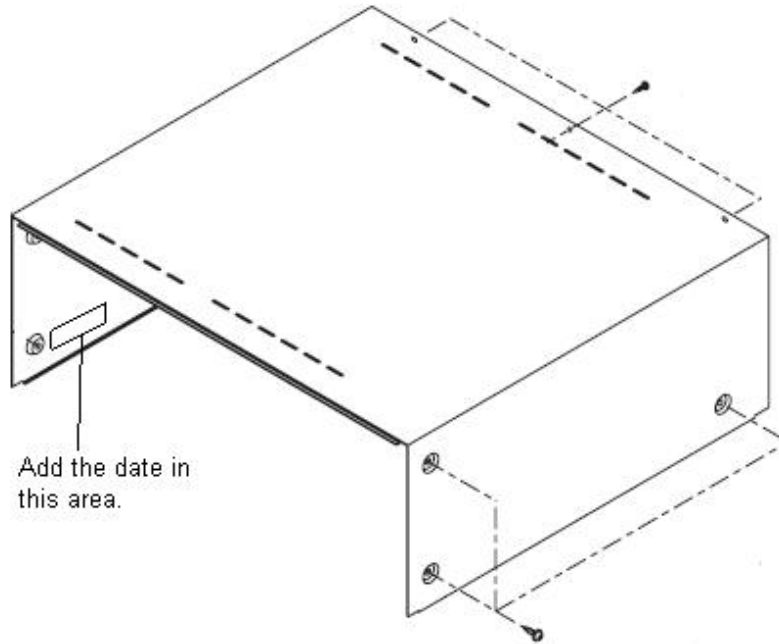

---

**CONFIDENTIALITY NOTICE:**

The information contained in this document is intended for the exclusive use by MARANTZ Authorized Service Centers and their employees. This document may contain information that is privileged, confidential and may be protected from disclosure under applicable laws and terms of the MARANTZ Service Agreement. Any distribution, disclosure, dissemination or copying of this document and the information it contains is prohibited. No responsibility will be accepted by MARANTZ for any damage, injury or loss resulting from the misuse of the information contained in this document.