

Service Manual

74SR73 / 02B/02G

Audio/Video surround stereo receiver

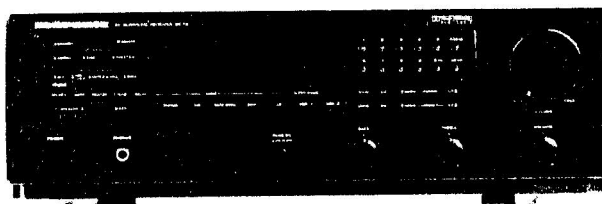

TABLE OF CONTENTS

SECTION	PAGE
1. TECHNICAL SPECIFICATIONS	1
2. BLOCK DIAGRAM	2
3. SCHEMATIC DIAGRAM AND PARTS LOCATION (Pattern side)	4
4. EXPLODED VIEW AND PARTS LIST	17
5. TEST EQUIPMENT REQUIRED FOR SERVICING	19
6. IDLING CURRENT ADJUSTMENT	19
7. SERVICE PROGRAM	19
8. TUNER ALIGNMENT PROCEDURES	19
9. ALIGNMENT AND TEST POINT	21
10. CIRCUIT DESCRIPTION	22
11. MICROPROCESSOR DATA	26
12. ELECTRICAL PARTS LIST	27

marantz®

model SR-73

First issue : 1993

A.O

4822 725 51045

PCS 71 638

MARANTZ DESIGN AND SERVICE

Using superior design and selected high grade components, MARANTZ company has created the ultimate in stereo sound. Only **original MARANTZ parts** can insure that your MARANTZ product will continue to perform to the specifications for which it is famous.

Parts for your MARANTZ equipment are generally available at our National Marantz Subsidiary or Agent.

MARANTZ EUROPE B.V.
P.O. Box 80002
Building SFF 2
5600 JB Eindhoven
The Netherlands
Phone : +31-40-732241
Fax : +31-40-735578

ORDERING PARTS

Parts can be ordered either by mail or by telex. In both cases, the correct part number has to be specified. The following information must be supplied to eliminate delays in processing your order:

1. Complete address
2. Complete part numbers and quantities required
3. Description of parts
4. Model number for which the part is required
5. Way of shipment
6. Signature: any order form or telex must be signed, otherwise such part order will be considered as null and void.

ADDRESSES

AUSTRALIA
MARANTZ AUSTRALIA
Figtree Drive
Australia Centre
Homebush, NSW 2140
AUSTRALIA

FINLAND
MARANTZ
Kuortanegatan 1
00520
Helsingfors 52
Finland

ITALY
MARANTZ ITALIANA SPA
Piazza IV Novembre 3
20124 Milano
Italy

NORWAY
MARANTZ
Postboks 7034
Assiden
3007 Drammen
Norway

SPAIN
MARANTZ SPAIN
Martinez Villergas 2
Apartado 2065
Madrid 28027
Spain

AUSTRIA
MARANTZ
Hietzinger Kai 137a
1130 Wien
Austria

FRANCE
MARANTZ FRANCE
4 Rue Bernard Palissy
92600 Asnières
France

JAPAN
MARANTZ JAPAN INC.
35-1, 7-chome, Sagamiono
Sagamihara-shi, Kanagawa
Japan

PORTUGAL
COREL
Av. da Liberdade
211-2 Esq.
1200 Lisboa
Portugal

SWEDEN
MARANTZ
Box 1324
17125 Solna
Sweden

BELGIUM
MARANTZ EUROPE B.V.
Div. Benelux
P.O.Box 80002
Building SFF 2
5600 JB Eindhoven
The Netherlands

GERMANY
MARANTZ GERMANY GmbH
Kleine Heide 12
Postfach 4802
Halle-Westfalen
Germany

KUWAIT
AL ALAMIAH ELECTRONICS
P.O.Box 8196
Salmiah
22052 Kuwait

SAUDI ARABIA
AL ALAMIAH ELECTRONICS
P.O.Box 5954
University Street
Riyadh 11432
Saudi Arabia

SWITZERLAND
MARANTZ SWITZERLAND
Postfach
8010 Zürich-Müllingen
Switzerland

CHILE
MARANTZ DIVISION OF
PHILIPS S.A.
Av.Santa Maria 0760
Casilla 2607
Santiago
Chile

GREAT BRITAIN
MARANTZ HIFI UK Ltd.
Kingsbridge House
Padbury Oaks
575-583 Bath Road
Longford Middlesex UB7 OEH,
U.K.

NETHERLANDS
MARANTZ EUROPE B.V.
Div. Benelux
P.O.Box 80002
Building SFF 2
5600 JB Eindhoven
The Netherlands

SOUTH AFRICA
MARANTZ S.A.
10 Bond Street
Randburg 2194
P.O. Box 7703
Johannesburg 2000
South Africa

TRADING
MARANTZ TRADING
P.O.Box 20008
Building SFF 2
5600 JB Eindhoven
The Netherlands

DENMARK
MARANTZ
Horsvinget 5
2630 Tastrup
Denmark

GREECE
ADAMCO ELECTR. SA
P.O.Box 21025
Hippocrates Str. 188
Athens 11471
Greece

All of the above locations are fully equipped to take care of your total service needs or can advise you. Because various countries have differing configuration requirements, it is necessary that you contact the service facility in your particular country. In the event that there is no service location listed for your country, please contact the nearest facility for the necessary assistance.

In case of difficulties, do not hesitate to contact the Technical Department at above mentioned address.

1. TECHNICAL SPECIFICATIONS

FM Tuner Section

Frequency Range	87.5 - 108.0 MHz
Usable Sensitivity	IHF 1.3 μ V / 13.5 dB
Signal to Noise Ratio	Mono / Stereo 78 / 70 dB
Distortion	Mono / Stereo 0.2 / 0.5 %
Stereo Separation	1 kHz 40 dB
A.C.S.	\pm 300 kHz 65 dB
Image Rejection	98 MHz 70 dB
Tuner Output Level	1 kHz, \pm 40 kHz Dev 940 mV

AM Tuner Section

Frequency Range	531 - 1602 kHz
Usable Sensitivity	Loop 500 μ V
Signal to Noise Ratio	50 dB
Distortion	1 kHz, 30 % Mod. 0.5 %
Selectivity	\pm 18 kHz 70 dB

Audio Section

Rated Power	
Front	20 Hz - 20 kHz 8 ohms 70 W / Ch
Center	1 kHz 8 ohms 80 W
Surround	1 kHz 4 ohms 40 W / Ch
THD Front	20 Hz - 20 kHz 8 ohms 0.09 %
Input Sensitivity / Impedance	
Phono	3.5 mV / 47 k ohms
Linear	220 mV / 30 k ohms
Phono Overload (1 kHz, 1 % THD)	
Phono	150 mV
Signal to Noise Ratio (IHF A) RATED Power	
Phono	77 dB
Linear	103 dB

Video Section

Input / Output Level / Impedance	1.0 V _{p-p} / 75 ohms
--	--------------------------------

Others

Power Supply	AC 230 V 50 / 60 Hz
Power Consumption	550 W

Dimensions

Width	16 - 3 / 4 inches (426 mm)
Height	5 - 1 / 4 inches (132 mm)
Depth	13 - 1 / 2 inches (341 mm)
Weight	21 lbs (9.4 kg)

Specifications subject to change without prior notice.

2. BLOCK DIAGRAM

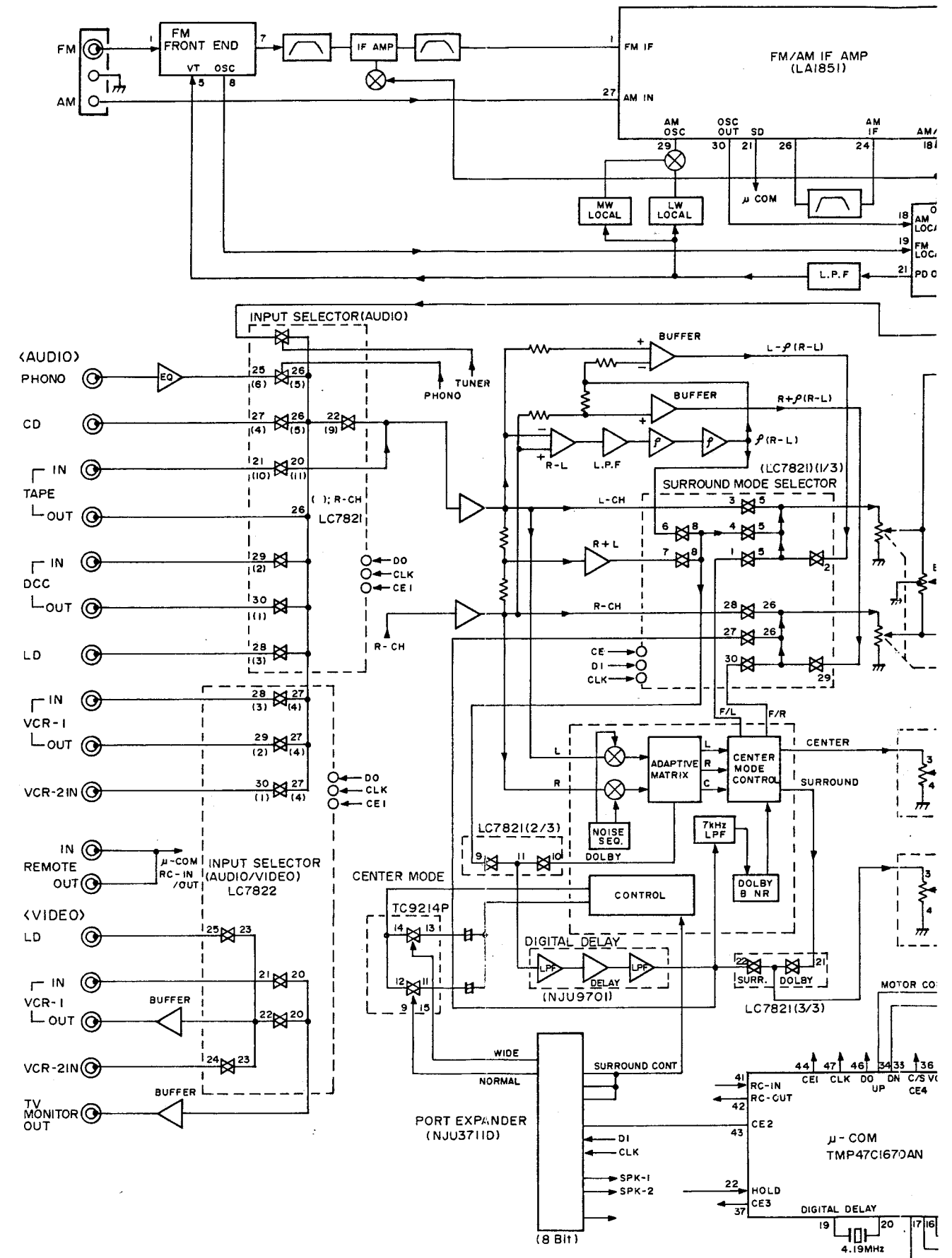

2. BLOCK DIAGRAM

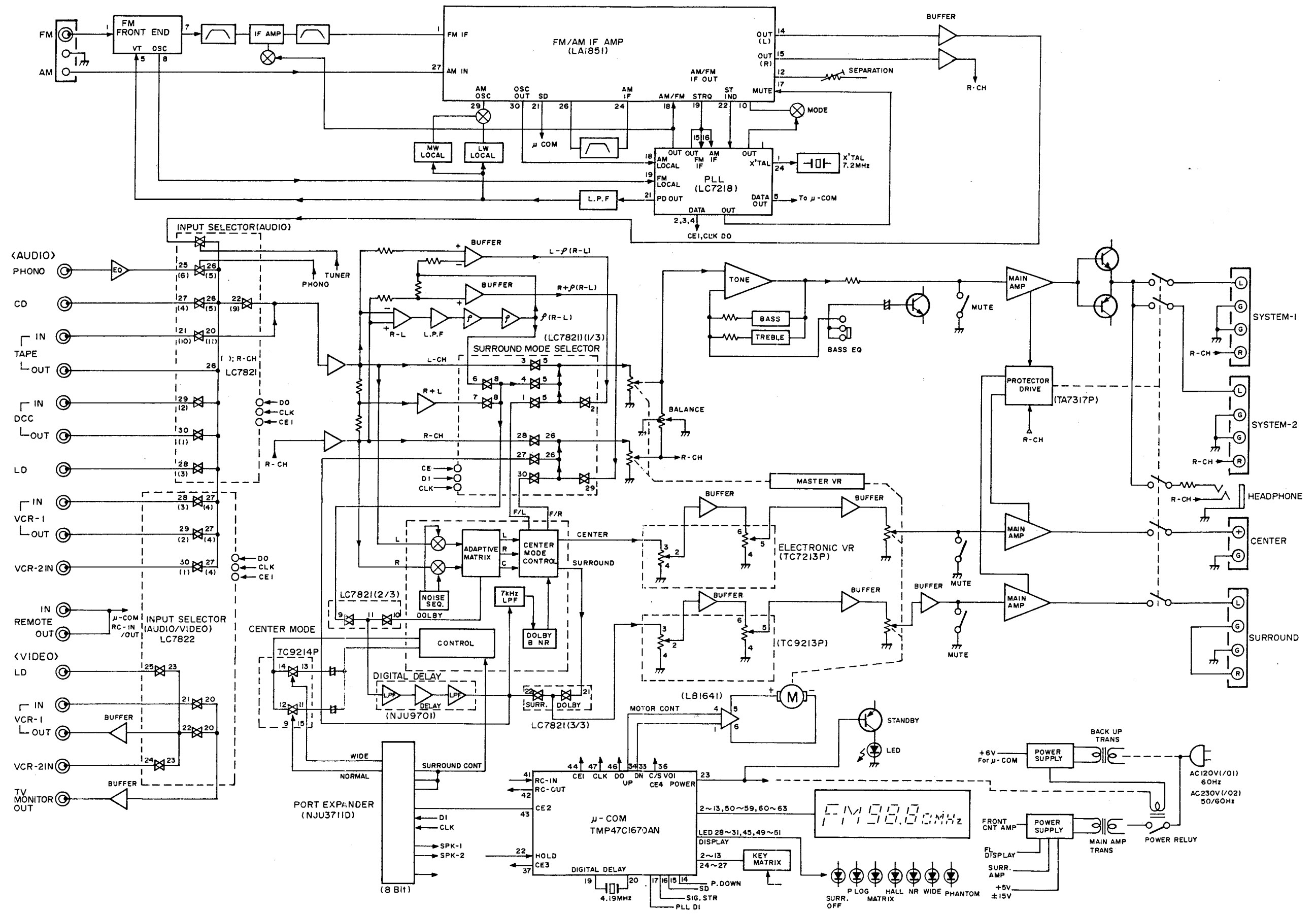

3. SCHEMATIC DIAGRAM AND PARTS LOCATION (Pattern side)

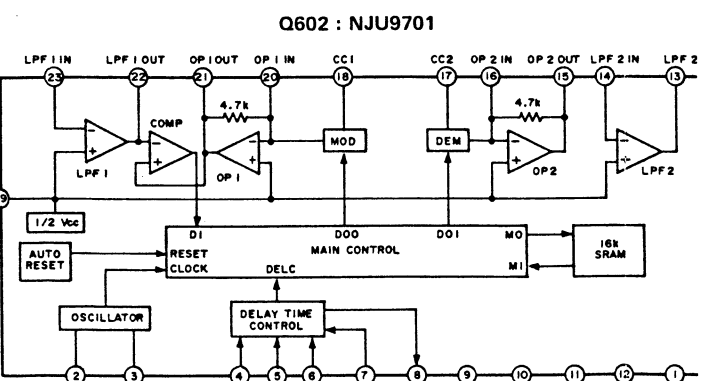
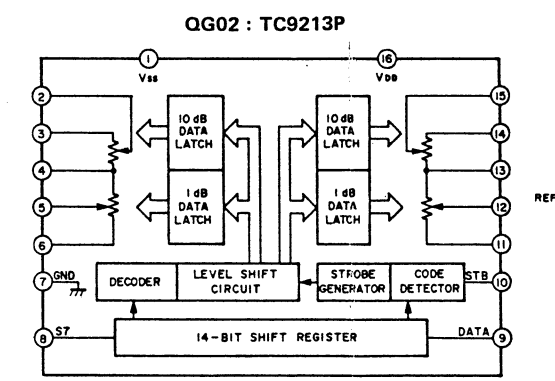
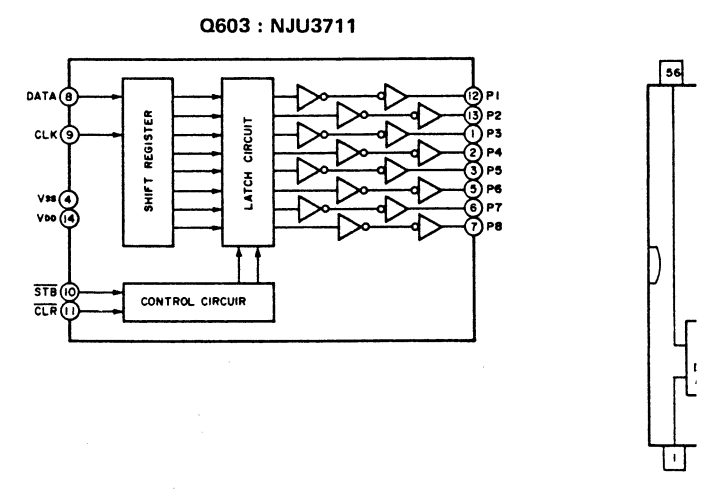
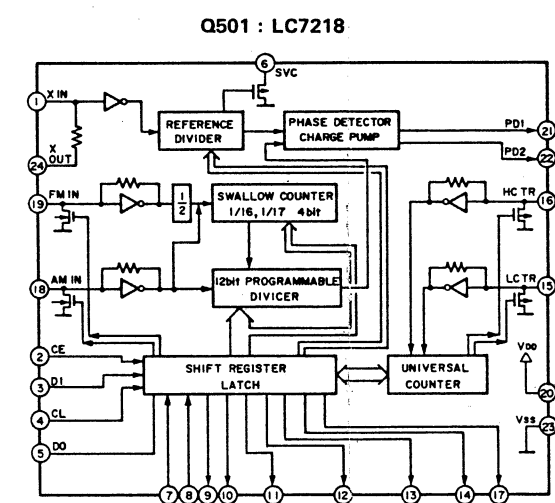
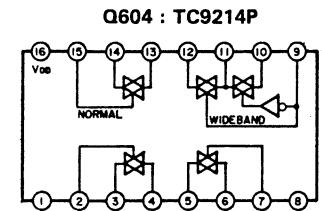
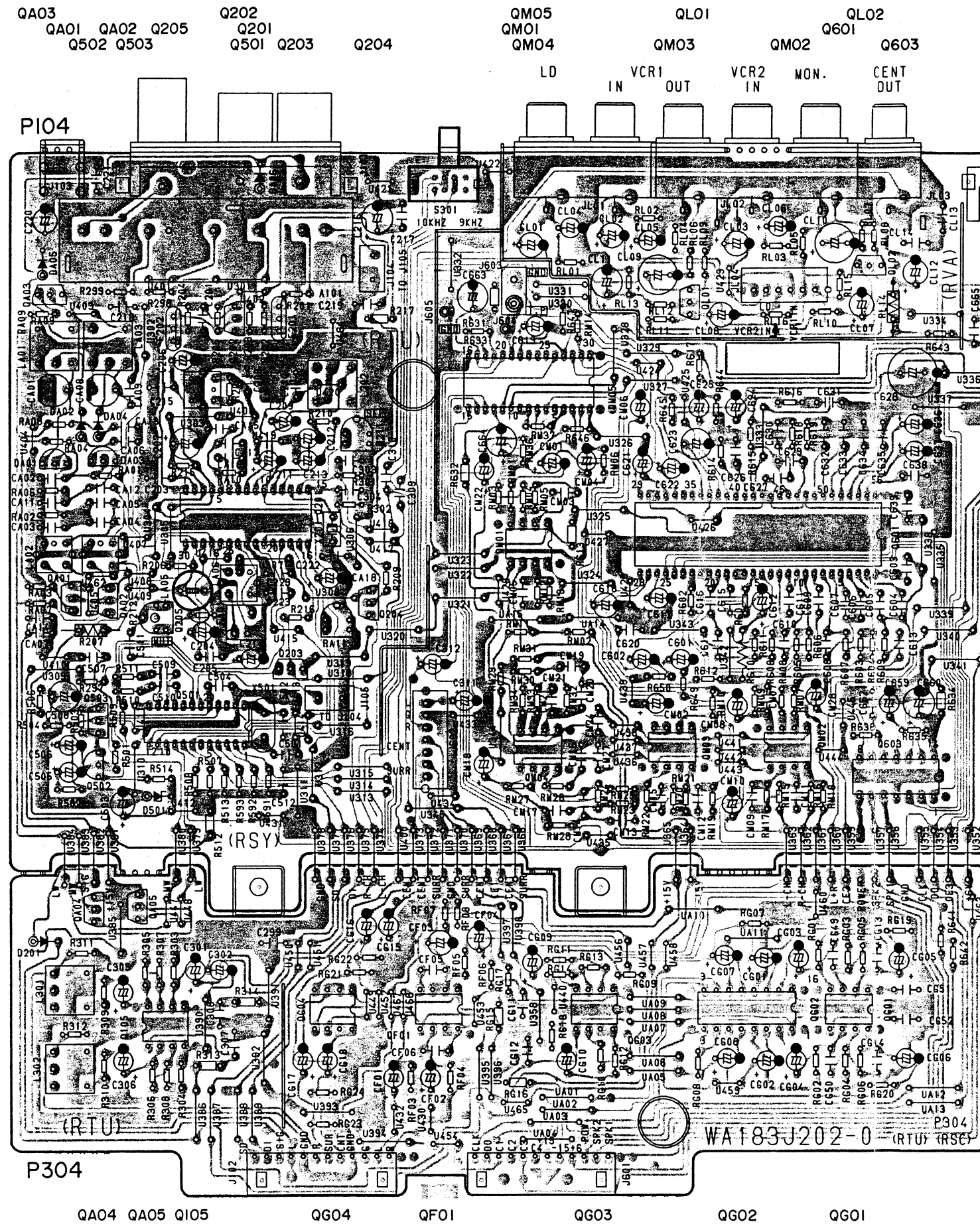

Q604 : TC9214P

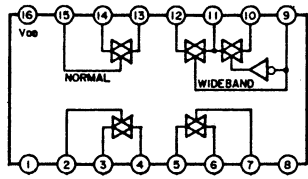

QM05,QV01,QV02 : LC7821

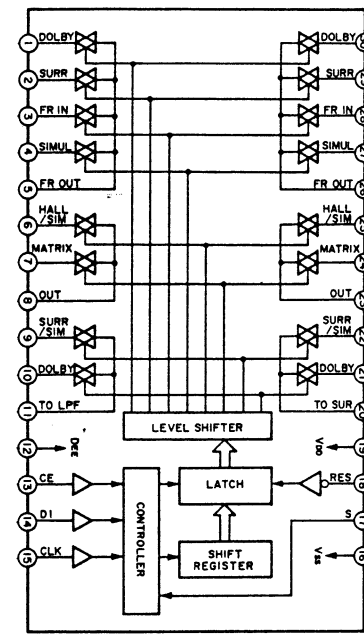

Q715 : AN7062N

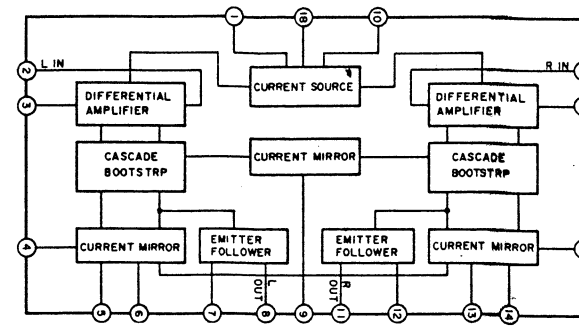

QN06 : TA7317P

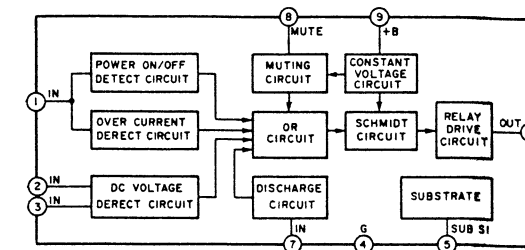

Q603

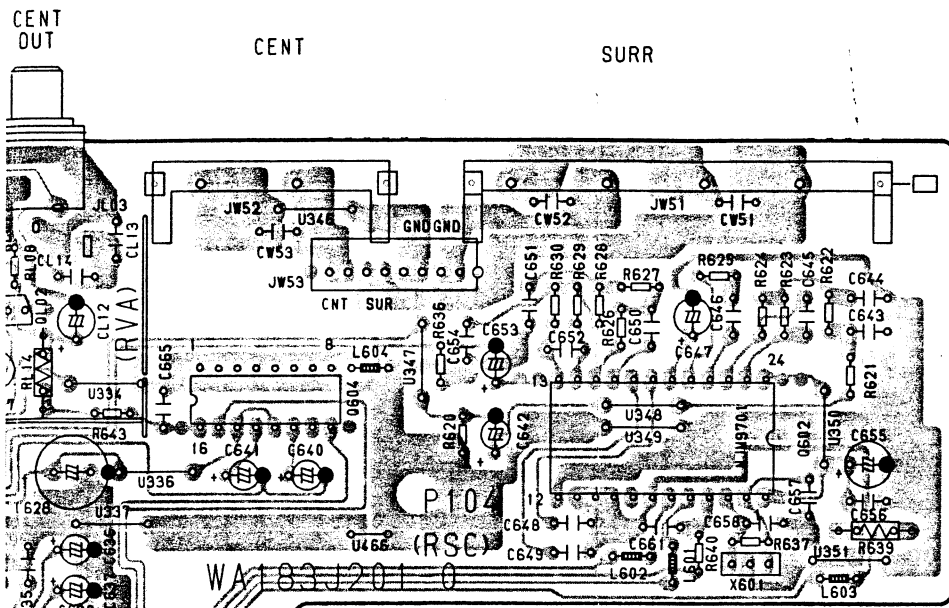

Q501 : LC7218

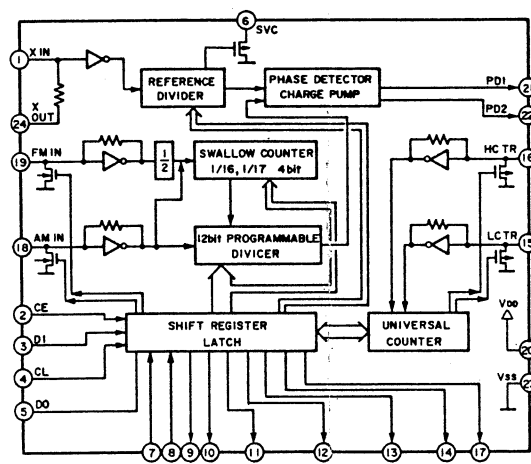

Q603 : NJU3711

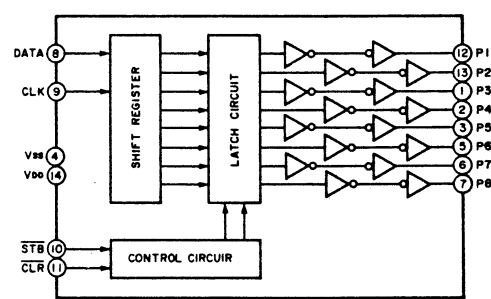

Q601 : NJM2177L

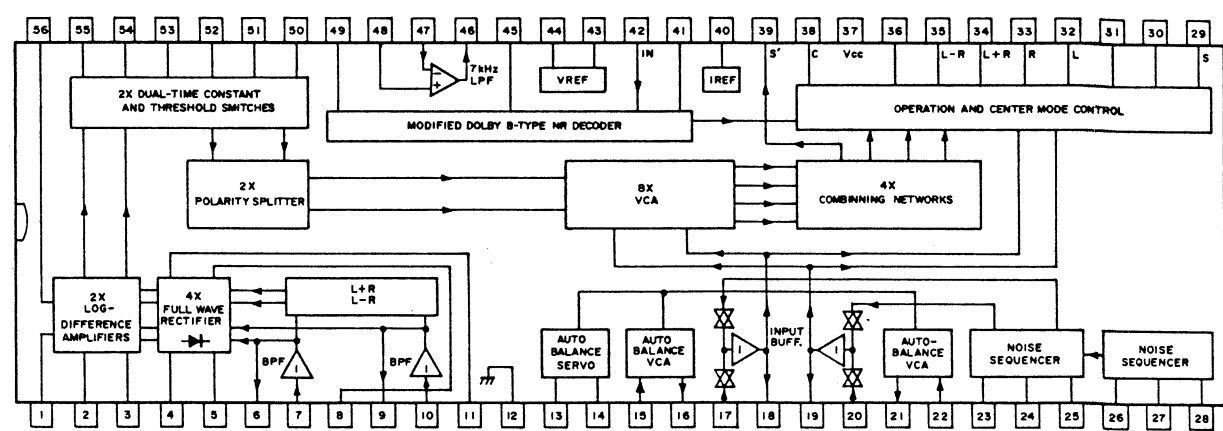

Q602 : TC9213P

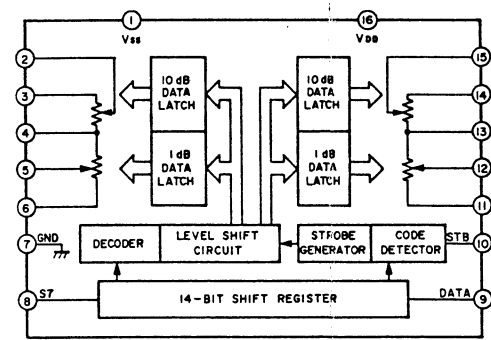

Q602 : NJU9701

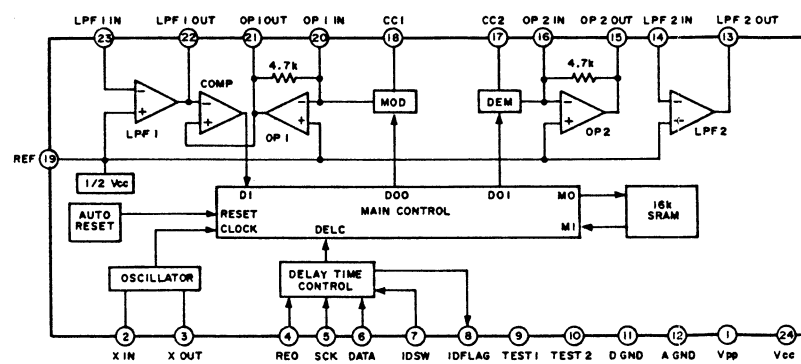

Q201 : LA1851N

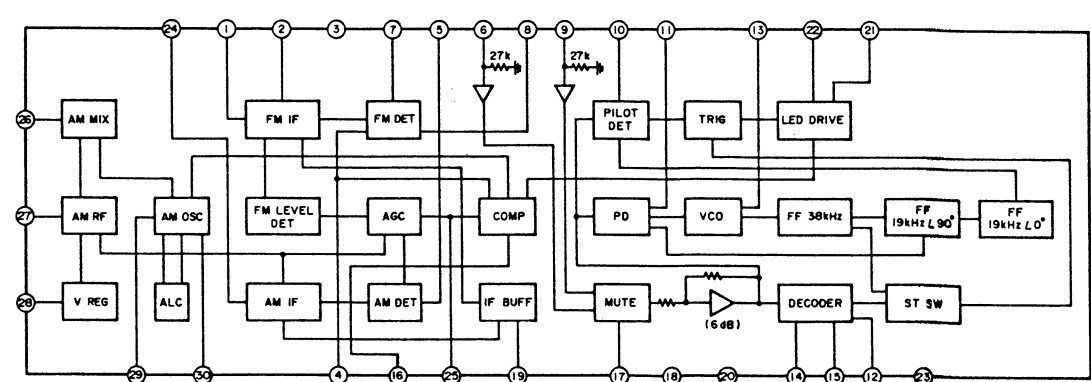

Q401 QV01 QN51~QN53 Q802 QV02 Q803 Q801 Q715 Q701~Q704 QN04 QN05
 QV03 QV04 QV07 QV08 QN06 Q714 Q710 Q706 Q708 Q712 QN02 QN03 QN72 QN71 QN01 Q713 Q709 Q705 Q707 Q711
 PV04

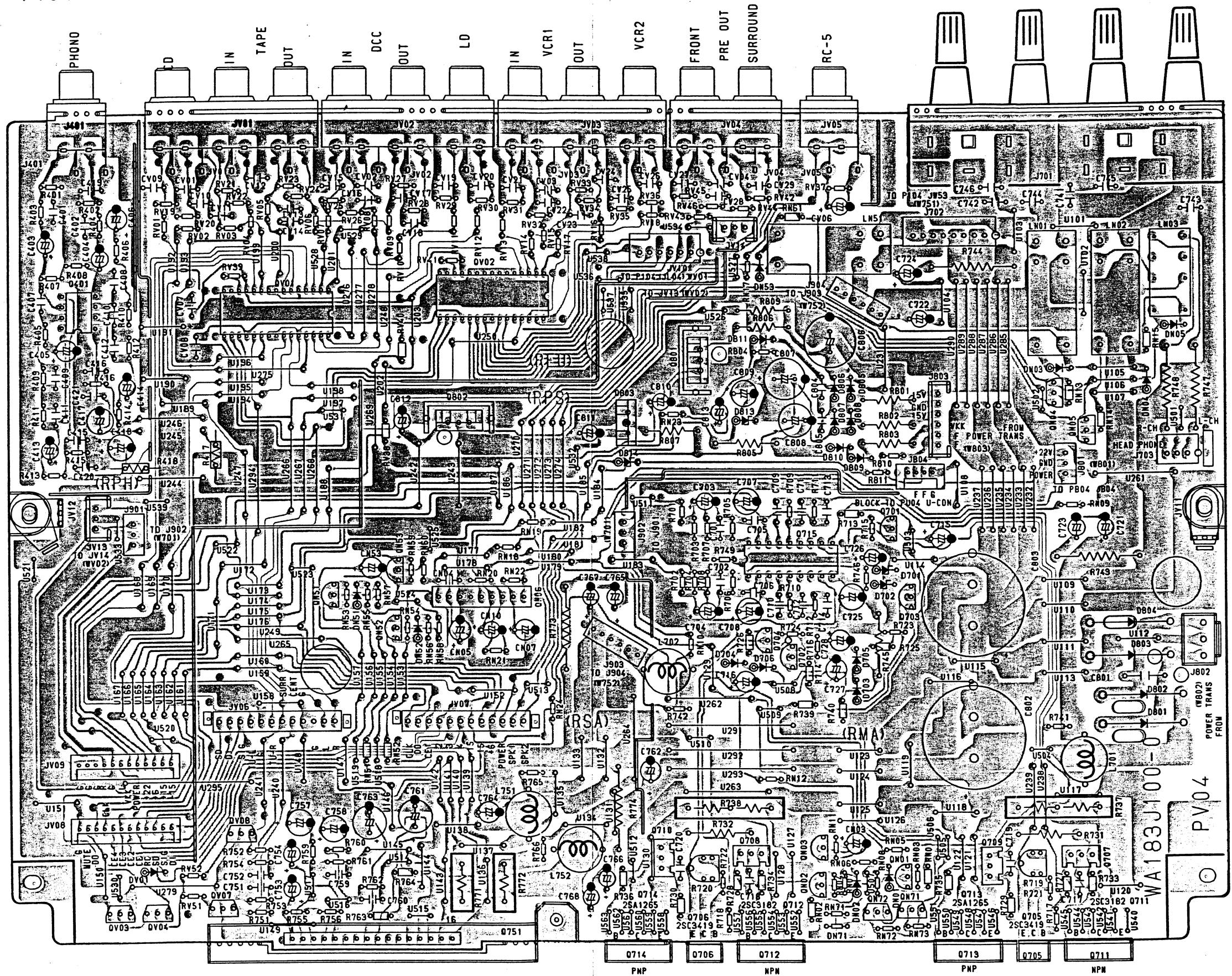

Q714 Q706 Q712 Q713 Q705 Q711
 PNP NPN PNP NPN

QB01
PB04

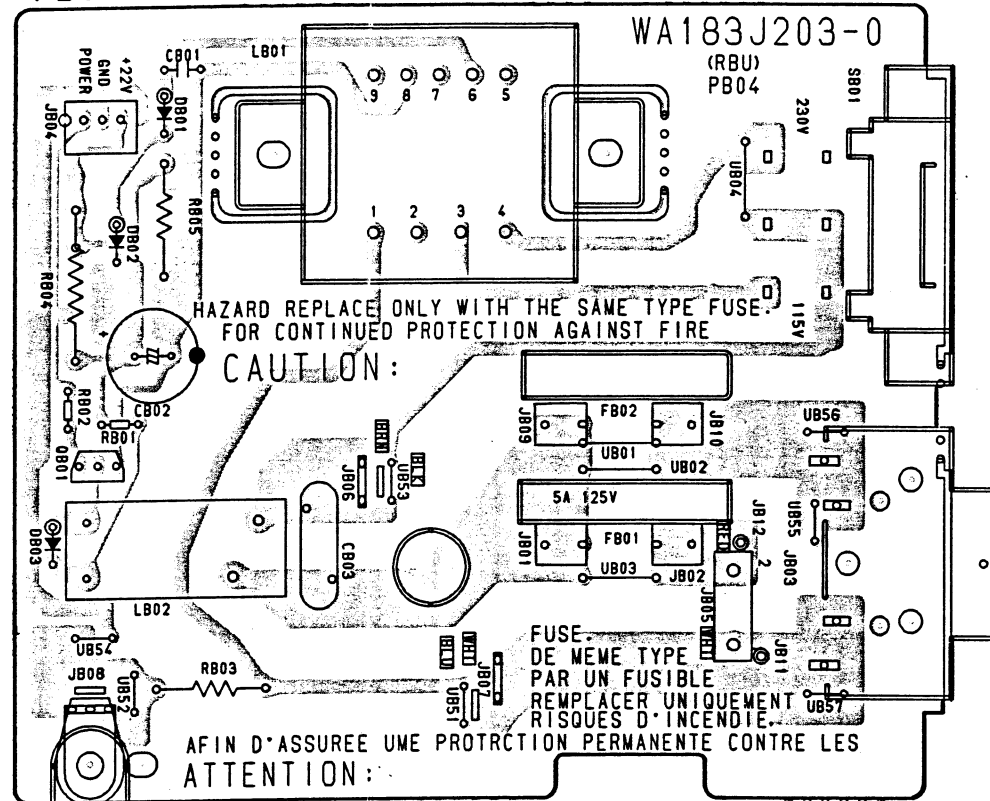

PT04

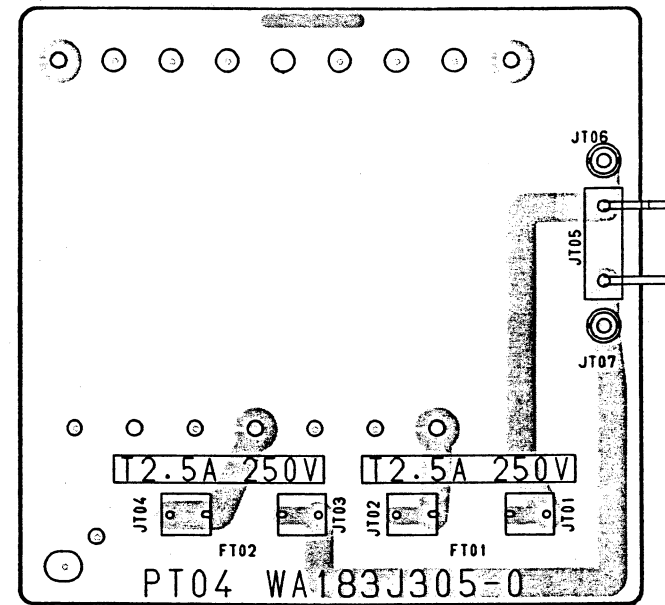

PW04

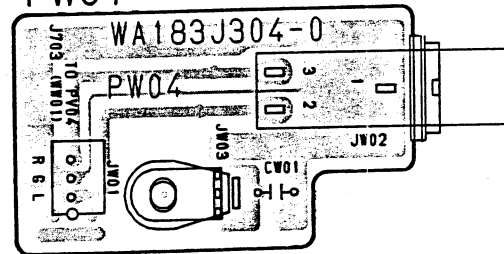

PG04

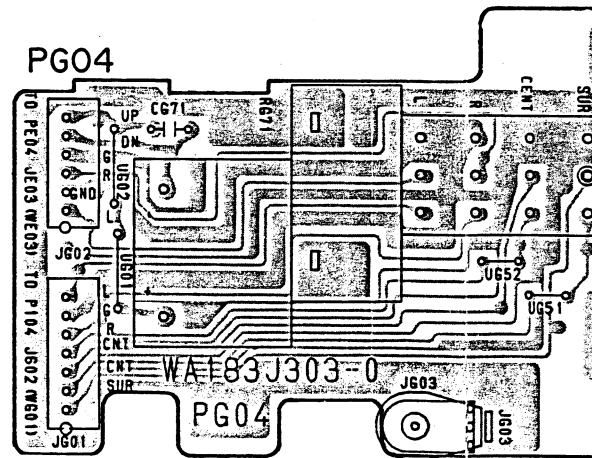

PG54

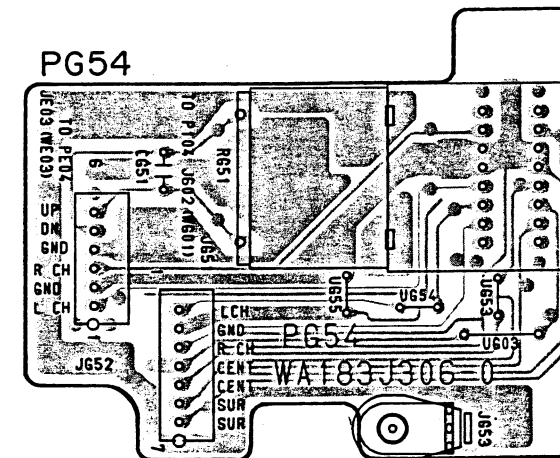

TO PG04 (RVR)
JG02 (WE03)

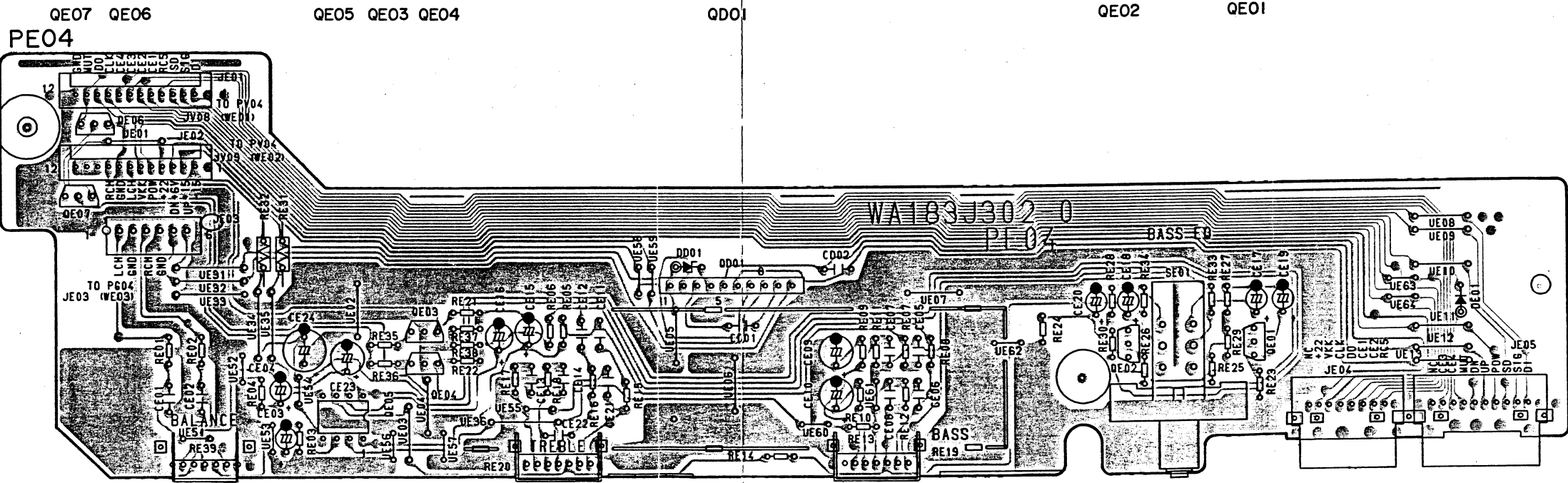
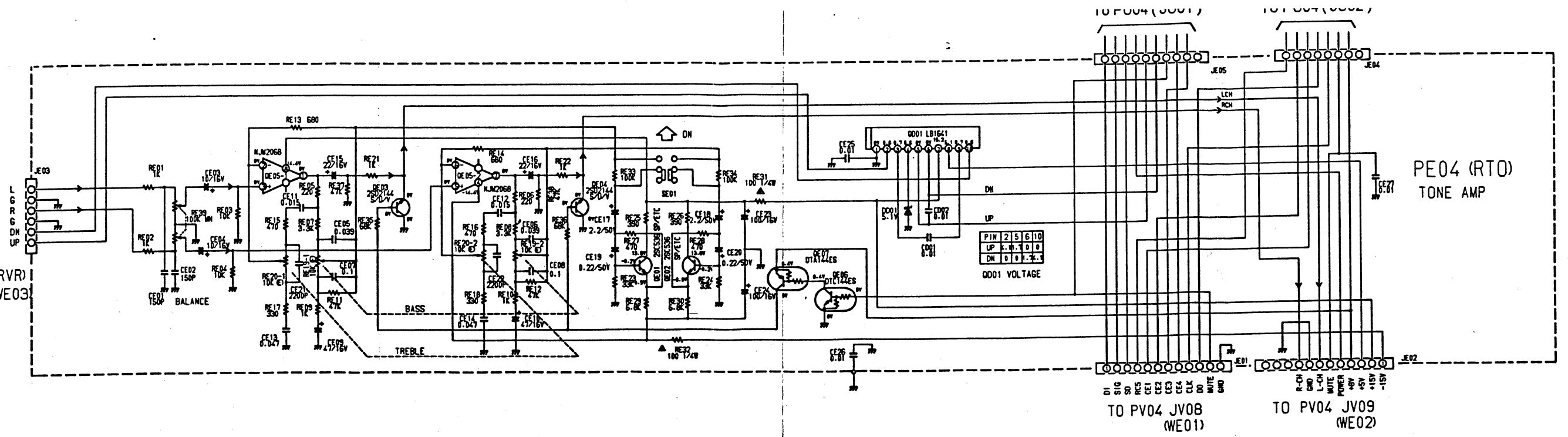

QD01 : LB1641

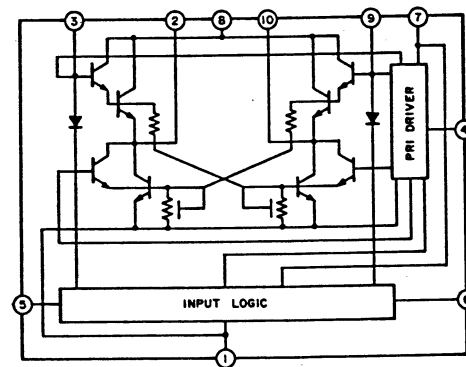

U-CON/DISPLAY BLOCK

PU04 (RMC)

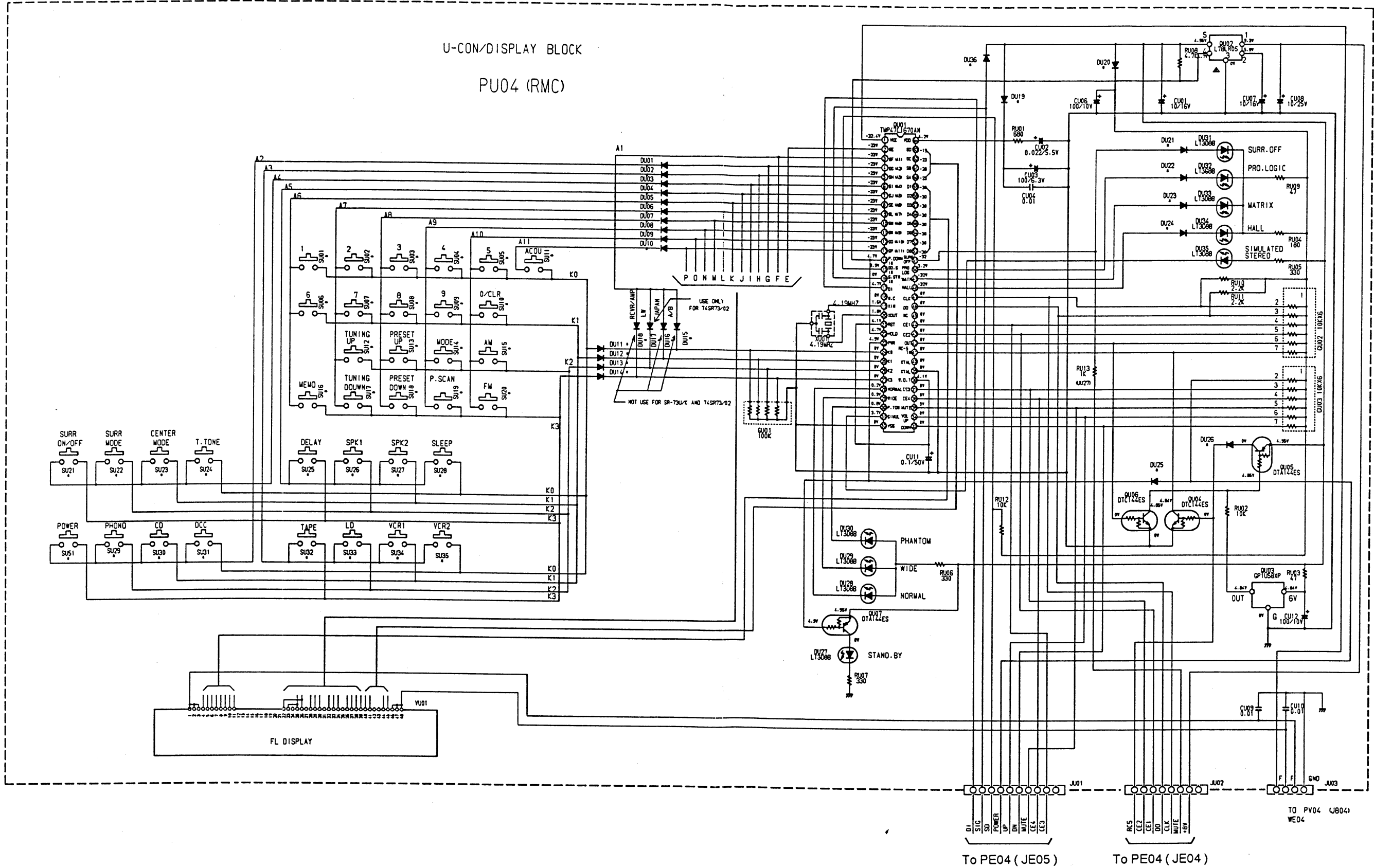

QU02
PU04

QU01

QU04 QU03 QU06 QU05

QU07

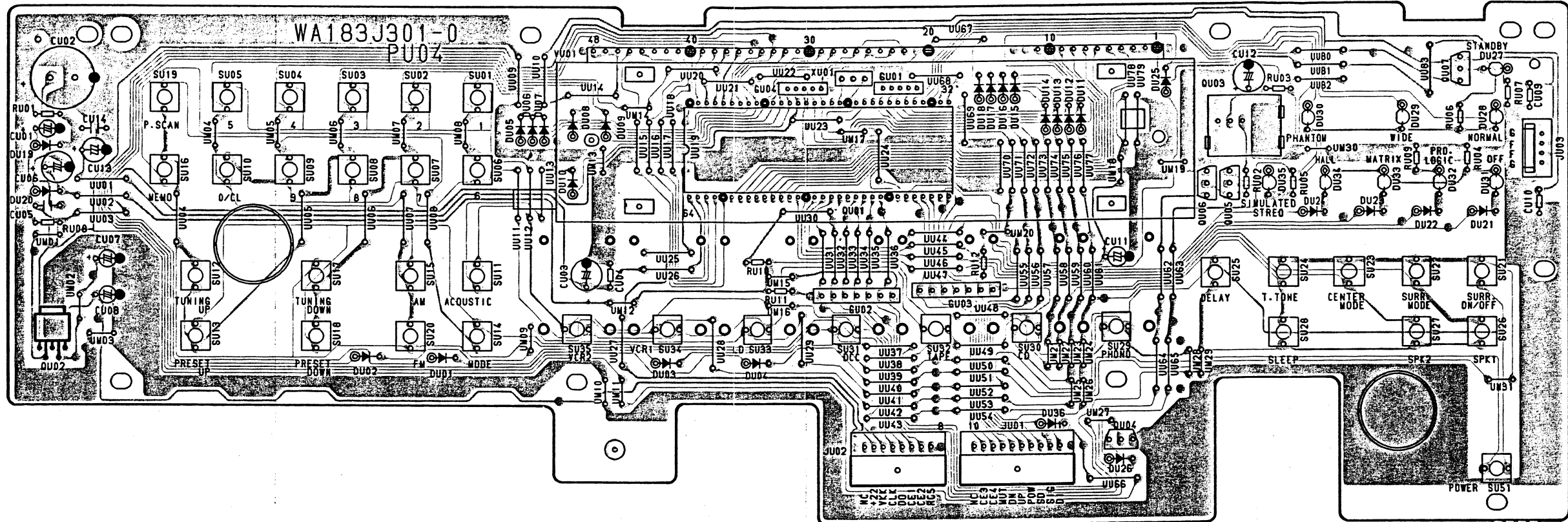

QU01 : TMP47C1670AN

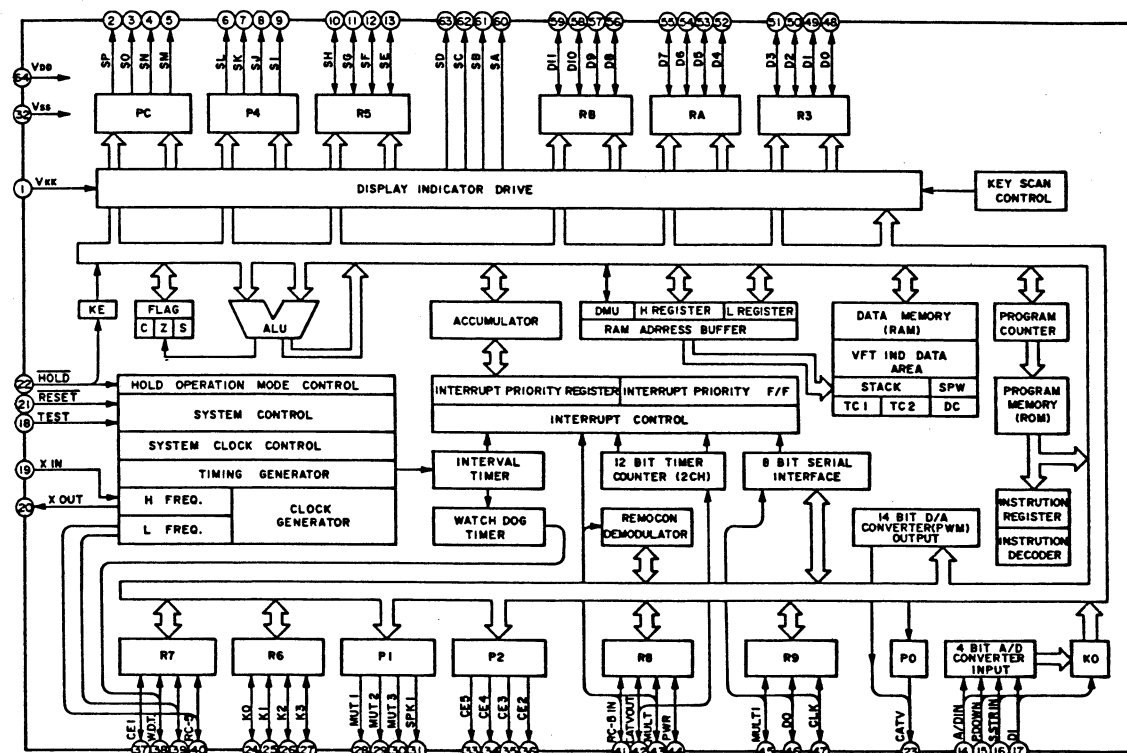

QU02 : L78LR05

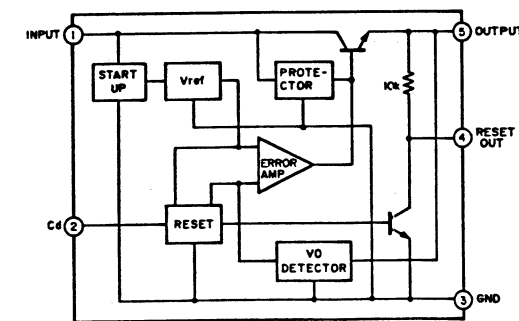

4. EXPLODED VIEW AND PARTS LIST

[U] : for U. S. A.
[K] : for Far East

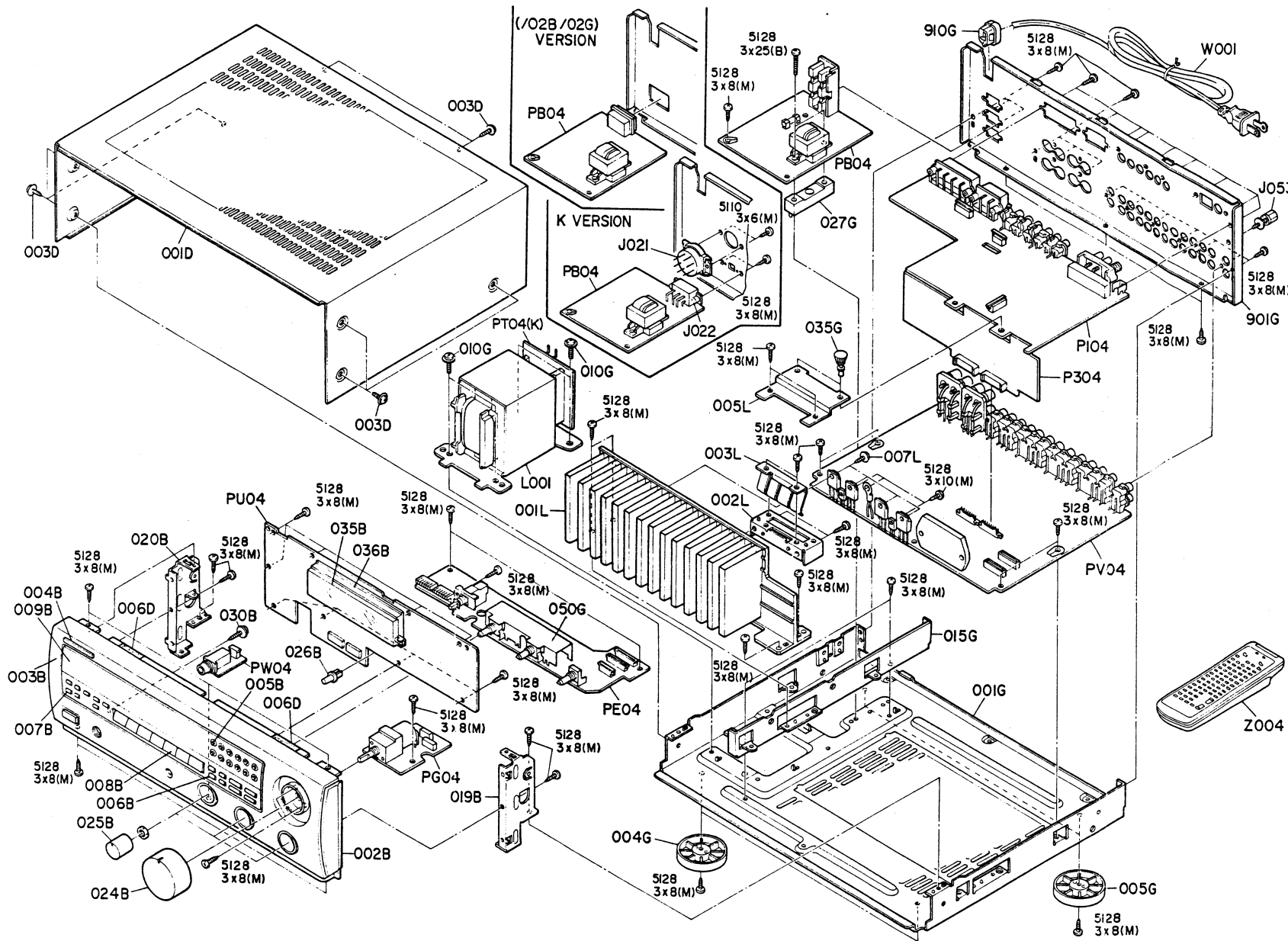

POS.NO	VERSION	PART NO. (FOR EUROPE)	DESCRIPTION	PART NO. (FOR U/K)
002B	/02B/ U/ K	4822 464 70618	Chassis, Front Mold (BLACK)	183J105020
	/02G/ K	4822 464 70625	Chassis, Front Mold (GOLD)	183J105120
003B	/02B/ U/ K	4822 426 51684	Front Panel (BLACK)	183J248010
	/02G/ K	4822 426 51701	Front Panel (GOLD)	183J248110
005B	/02B/ U/ K	4822 410 62848	Button, preset (BLACK)	183J270010
	/02G/ K	4822 410 62878	Button, preset (GOLD)	183J270110
006B	/02B/ U/ K	4822 410 62849	Button, Tuning (BLACK)	183J270020
	/02G/ K	4822 410 62879	Button, Tuning (GOLD)	183J270120
007B	/02B/ U/ K	4822 410 62851	Button, Surround (BLACK)	183J270030
	/02G/ K	4822 410 62881	Button, Surround (GOLD)	183J270130
008B	/02B/ U/ K	4822 410 62852	Button, Function (BLACK)	183J270040
	/02G/ K	4822 410 62882	Button, Function (GOLD)	183J270140
009B		4822 450 62137	Window	183J158010
024B	/02B/ U/ K	4822 413 41679	Knob, Volume	063J154080
	/02G/ K	4822 413 41683	Knob, Volume	063J154090
025B	/02B/ U/ K	4822 413 41678	Knob, Tone / Balance	025J154080
	/02G/ K	4822 413 41682	Knob, Tone / Balance	025J154090
026B	/02B/ U/ K	4822 410 60343	Button, Bass EQ	058J270030
	/02G/ K	4822 410 60334	Button, Bass EQ	058J270130
035B		4822 256 92097	Holder, FL	183J270020
036B		4822 459 10942	Sticker, FL	056J122020
003D		4822 502 12511	B.T. Screw (W / W) M3 x 8	51260308M0
004G		4822 462 42045	Leg, Front	183J057010
005G		4822 462 42048	Leg, Rear	183J057110
010G		4822 502 12511	B.T. Screw (W / W) M3 x 8	51260308M0
910G		4822 532 60948	Bushing, AC Cord	450H259010
007L		4822 502 13851	B.T. Screw (W / W) M3 x 15	51260315M0
▲J021	K		Voltage Selector	BY05080060
▲J022	K		Slide Switch, Voltage Selector	SS02021290
J053		4822 290 40297	Terminal, GND	YL03010280
▲L001	U		Power Transformer	TS18626030
	/02B/ 02G	4822 146 21761	Power Transformer	TS18626040
	K		Power Transformer	TS18626050
Z001	U		FM Ext. Antenna	ZA02000070
Z001	/02B/ 02G	4822 303 50079	FM Ext. Antenna	ZA01000010
Z003		4822 157 63083	Loop Antenna, LA-700HB	LA00055010
Z004		4822 218 10525	Remote Control	ZK183J0010
001T	U/ K		User Manual	183J851250
	/02B/ 02G	4822 736 21885	User Manual	183J851310

5. TEST EQUIPMENT REQUIRED FOR SERVICING

This table lists the test equipment required for servicing.

Item	Use
Distortion Analyzer	Distortion measurements
Audio Oscillator	Sinewave and squarewave signal source
ACVTVM	Voltage measurements (AC)
Oscilloscope	Waveform analysis and trouble shooting and ASO alignment
Circuit Tester	Trouble Shooting
DCVTVM	Voltage measurements (DC)
AC Wattmeter	Monitors primary power to amplifier
Line Voltmeter	Monitors potential of primary power to amplifier
Variable Autotransformer	Adjust level of primary power to amplifier
Shorting Plug	Shorts amplifier input to eliminate noise pickup

6. IDLING CURRENT ADJUSTMENT

- Before switching the power ON, set the Master Volume control to the minimum position and the Balance and Tone controls to the center positions. Then, rotate the semi-fixed resistors R719 (L CH) and R720 (R CH) on the PC board PV04 fully clockwise.
- Connect a digital voltmeter, set for the DC voltage input to the pertinent test points (the marked ones of R737-R738) on the PC board PV04. (Positive: Left side, Negative: Right side)
- After the completion of the above setup. Switch the power ON and adjust the semi-fixed resistors R719 (L CH) and R720 (R CH) on the PC board PV04 according to the reading of the digital voltmeter. The setting values are 7 mV (19 mA) of the both channels.

Please refer to the table below.

Power ON

30 sec. ~ 1 min.	4 mV
1 ~ 2 min. later	5 mV
More than 5 min.	7 mV

Measurement point

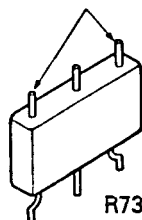

R737/R738

8. TUNER ALIGNMENT PROCEDURES

- When you adjust a set, use a signal generator with a counter with which you can correctly read frequencies, or connect a counter to a signal generator with a counter terminal for both AM and FM.
- As a rule, use a band-pass filter (B.P.F 200-15 kHz) designated by IHF in adjustment and measurement of FM.
Be sure to use a filter especially in adjustment of STEREO DISTORTION and SEPARATION. (Attenuation at 19 kHz is to be 30 dB at least.)

7. SERVICE PROGRAM

- T.R POINT ME (tracking point memory) mode.**
From power OFF (stand-by mode), when the POWER switch is pressed ON while pressing the MEMO and PRESET DOWN key, the T.R POINT ME mode is called. Frequencies to be memorized are as follows.

	P1	P2	P3	P4	P5	P6	P7	P8
FM	90.0 MHz	98.0 MHz	106.0 MHz	87.5 MHz				
AM					603 kHz	999 kHz	1404 kHz	173 kHz

	P9	P10	P11	P12-P30
FM				
AM	209 kHz	272 kHz	152 kHz	531 kHz

- The controller (QU01) used in this set has a function to preset and memorize the frequencies of guard and tracking point to be used in adjustment and measurement.

- Before alignment, connect a dummy resistor of 47 kohms to the tape out terminal.

4. FM Alignment Procedures

(Function switch at "FM" position and MODE switch at "AUTO STEREO" position)

• FM RF Alignment

Step	Signal Source Connection	Signal Frequency	Indicator Connection	Digital Readout Frequency Setting	Adjust
1	FM signal generator to FM antenna terminal. Adjust the RF signal output so that slight noise occurs at the upper and lower sides of the output waveform.	98.0 MHz	AC VTVM to L- or R-channel output (TAPE OUT)	98.0 MHz (P2)	Front end IFT for maximum output and minimum distortion.
2	FM signal generator 500 μ V output to FM antenna terminal (75-ohm). Modulation 1 kHz 53.3% (40 kHz)	98.0 MHz	Distortion meter to L- or R-channel output (TAPE OUT)	98.0 MHz (P2)	L201 core fore minimum distortion.

• FM IF Alignment

(Function switch at "FM" position and MODE switch at "AUTO STEREO" position)

Step	Signal Source Connection	Signal Frequency	Indicator Connection	Digital Readout Frequency Setting	Adjust
1	FM signal generator 500 μ V output modulated by MPX signal generator to FM antenna terminal (75-ohm). Modulation level: IHF 53.3% (40 kHz) +8% pilot dev.	Stereo L-channel (1,000 Hz)	VTVM to L-channel output (TAPE OUT L channel)	98.0 MHz (P2)	Front end IFT for minimum distortion.
2		Stereo R-channel (1,000 Hz)	VTVM to R-channel output (TAPE OUT R channel)		

• Muting Level Alignment

(Function switch at "FM" position and MODE switch at "AUTO STEREO" position)

Step	Signal Source Connection	Signal Frequency	Indicator Connection	Digital Readout Frequency Setting	Adjust
1	FM signal generator 6.3 μ V output to FM antenna terminal (75-ohm)	98.0 MHz		98.0 MHz (P2)	R212 to a point at which shows "tuned."

• Multiplex Alignment

(Function switch at "FM" position and MODE switch at "AUTO STEREO" position)

Step	Signal Source Connection	Signal Frequency	Indicator Connection	Digital Readout Frequency Setting	Adjust
1	FM signal generator 500 μ V output modulated by MPX signal generator to FM antenna terminal (75-ohm). Modulation level: IHF 53.3% (40 kHz) +8% pilot dev.	Stereo L-channel (1,000 Hz)	VTVM to R-channel output (TAPE OUT R channel)	98.0 MHz (P2)	R211 so that channel separation is identical between both channels.
2		Stereo R-channel (1,000 Hz)	VTVM to L-channel output (TAPE OUT L channel)		
3	Repeat steps 1 and 2.				

5. AM Alignment Procedures
(Function switch at "AM" position)

● **AM IF Alignment**

Step	Signal Source Connection	Signal Frequency	Indicator Connection	Digital Readout Frequency Setting	Adjust
1	Sweep generator to AM antenna terminal	450 kHz	AC VTVM to L- or R-channel output (TAPE OUT)	—	LA06 Maximum and symmetrical waveform.

● **AM RF Alignment**

Step	Signal Source Connection	Signal Frequency	Indicator Connection	Digital Readout Frequency Setting	Adjust
1	AM signal generator to AM loop antenna in a test loop	(MW) 603 kHz (LW) 173 kHz	VTVM to L- or R-channel output (TAPE OUT)	(MW) 603 kHz (P5) (LW) 173 kHz (P8)	(MW) LA01 for maximum output. (LW) LA03 for maximum output.
2		(MW) 1404 kHz (LW) 272 kHz		(MW) 1404 kHz (P7) (LW) 272 kHz (P10)	(MW) CA01 for maximum output. (LW) CA08 for maximum output.
3	Repeat steps 1 and 2 until sensitivity is maximized.				

● **AM Auto Stop Alignment**
(Function switch at "AM" position)

Step	Signal Source Connection	Signal Frequency	Indicator Connection	Digital Readout Frequency Setting	Adjust
1	RF generator to AM loop antenna in a test loop (500 μV/m)	999 kHz	—	999 kHz (P6)	RA11 so that shows "TUNED" on the display.

9. ALIGNMENT AND TEST POINT

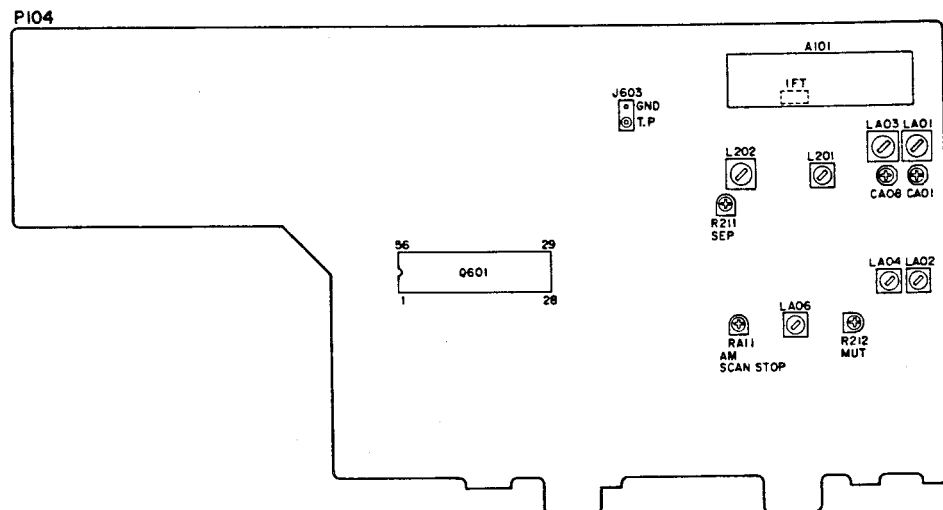

10. CIRCUIT DESCRIPTION

1. Input Selector

- Input selector
The function of this circuit is to select between the components connected to the rear panel. The circuit uses an LC7821 IC (QV01), which is serially controlled by the microprocessor (QU01).

2. Surround Block

- The surround block consists of a buffer amplifier, phase shifter, Dolby Pro Logic decoder and its controller, and digital delay and surround mode switches.
- Buffer amplifier
The stereo signal is first input into this buffer amplifier (QF01), which provides a 0 dB gain at all frequencies. After passing through the amplifier, the signal is distributed to the various blocks.
- Phase shifter and adder
Here the phase of the signal from low range to high range frequencies is shifted. First, the L/R signals are input to the QM02-2 and the L-R (phase difference component) signal is extracted. This L-R signal passes through the phase shifter (QM03, QM04) and then enters the matrix circuit (QM01). Here the L-R signal is applied in reverse phase to the L signal and in same phase to the R signal. These signals then become the front L and R signals for the MATRIX and HALL surround modes. The adder (QM02-1) produces an L+R signal which is used as the surround signal in the HALL surround mode and as the L channel signal in SIMULATED STEREO mode.
- Dolby Pro Logic decoder
This circuit uses a Pro Logic decoder to decode a Dolby-encoded signal into four signals for the front left, front right, center and surround channels. The IC used is an NJM2177L (Q601). This circuit operates together with center mode control.
This IC has 2-channel and 3-channel modes in addition to the Dolby Pro Logic 4-channel mode, but in this unit the IC is used for 4-channel operation only. (See the Q601 Function Table.) Also, the center mode is controlled by the NJU3711 (Q603) and TC9214P (Q604).

The signal output from the buffer amplifier (QF01) is input to the L and R input pins of the Dolby Pro Logic decoder (Q601, pins 15 and 22). The front L and R channel signals decoded here are then output from pins 32 and 33 of Q601 and input to the surround mode selector (QM05). These signals are then output as the front L and R channel signals whenever the unit is set to Dolby surround mode. In the same way, the center signal is output from pin 38 of Q601 and input to the CENTER volume (QG02).

The surround signal is output from pin 39 of Q601, input to the surround mode selector (QM05), and then sent to the digital delay circuit (Q602). After the signal is applied with a delay in this circuit, it is returned to the Q601 and input to the Dolby B decoder circuit. The signal is then output from pin 39 of Q601 as the final surround signal. After that, the signal passes through QM05 and enters the SURROUND volume (QG02).

There are three center modes—NORMAL, PHANTOM and WIDE. Control of these modes is carried out by the TC9214P (Q604), which is in turn controlled by the port expander NJU3711 (Q603). The center mode control signal from the microprocessor is input as serial data from pins 43, 46 and 47 of QU01 to pins 8, 9 and 10 of Q603 to set each of Q603's ports to H or L. The control pins of the analog switch (Q604) connected to these ports turn the internal switches ON/OFF to control the Q601's center mode. (See the Q601 Function Table.) When the center mode is set to NORMAL, the center channel signal's low-frequency component is output to the front L and R channels. In PHANTOM mode, since no center speaker is used, the entire center channel signal is distributed to the front L and R channels. The Q603, in addition to controlling the center mode, also carries out control of the Q601 noise sequencer and speaker system 1 and 2. The noise sequencer functions to generate the signal used to adjust the balance of each channel in Dolby Pro Logic mode. When the TEST TONE switch is pressed ON, the noise sequencer outputs pink noise to each channel in sequence at 1.5-second intervals in the order: L → CENTER → R → SURROUND → L. (See the Q601 Function Table.)

NJM2177L (Q601) Function Table

NOISE SEQUENCER				OPERATION MODE		
PIN NAME PIN No.	NOISE-CNT-E PIN 23	NOISE-CNT-A PIN 24	NOISE-CNT-B PIN 25	PIN NAME PIN No.	MODE-CNT PIN 31	Note
SIGNAL SELECT	H	X	X	2CH (Lt, Rt, S')	L	S' = Lt-Rt or NOISE
NOISE L	L	L	L	3CH (L, C, R, S')	High Z	S' = Lt-Rt or NOISE
NOISE C	L	L	H	4CH (L, C, R, S', S)	H	
NOISE R	L	H	L	CENTER MODE		
NOISE S	L	H	H	PIN NAME PIN No.	CENTER-CNT PIN 30	CENTER-MODE PIN 36
				CENTER OFF	L	X
				NORMAL	H	0.22 μF
				PHANTOM	H	OPEN
				WIDEBAND	H	10 μF

- **Digital delay**
This circuit uses the NJU9701 (Q602) to add a time delay to the surround channel signal when a surround mode is selected, and is controlled by the microprocessor.

10 kHz active filters (L.P.F.) are placed on both the input side and output side of the delay circuit. Each filter has a gain of -9.4 dB and 4.4 dB. The delay times used for the various modes are as follows:

DOLBY: 15 ~ 30 ms, MATRIX/HALL/SIMULATED:

2 ~ 33 ms.

Initial delay settings are as follows:

DOLBY/MATRIX/HALL: 20 ms, SIMULATED:

10 ms

- **Surround mode selector**
The LC7821 (QM05) is used for the surround mode selector, which switches the surround modes in the following sequence:

OFF → DOLBY → MATRIX → HALL → SIMULATED

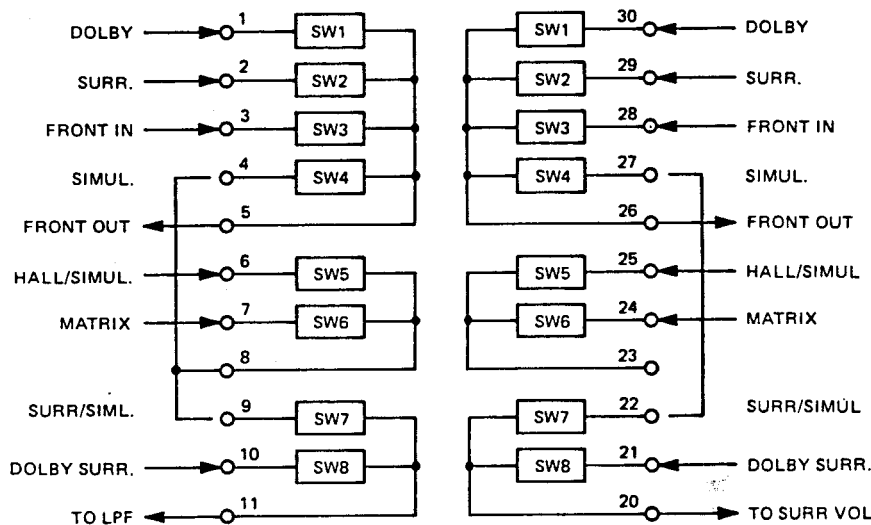

LC7821 (QM05) Function Table

SURROUND SELECTOR	SWITCH No.							
	1	2	3	4	5	6	7	8
OFF	0	0	1	0	X	X	X	X
DOLBY	1	0	0	0	0	0	0	1
MATRIX	0	1	0	0	0	1	1	0
HALL	0	1	0	0	1	0	1	0
SIMULATED STEREO	0	0	0	1	1	0	1	0

0 = SWITCH OFF
1 = SWITCH ON
X = DON'T CARE

3. Master Volume

- The master volume (RG01) is a motor-driven quadruple potentiometer for controlling the volume of the front left, front right, center and surround channels. Control of the motor is carried out by the LB1641 (QD01). QD01 is a motor drive IC with pins 5 and 6 used for input and pins 2 and 10 used for output.

LB1641 (QD01) Function Table

Volume	Input		Output	
	6	5	2	10
UP	L	H	H	L
DOWN	H	L	L	H
STOP	L	L	L	L

4. Center/Surround Volume

- Electronic potentiometers (TC9213P) are used for the center channel and surround channel volume (QG02). One potentiometer consists of an element for varying the volume in 10 dB steps and an element for varying the volume in 1 dB steps. Buffer amplifiers (QG01, NJM4558DD) are located between the elements.

QD01 is controlled by the NJU3711 (Q603). Q603 is controlled by serial data from the microprocessor.

Key Matrix

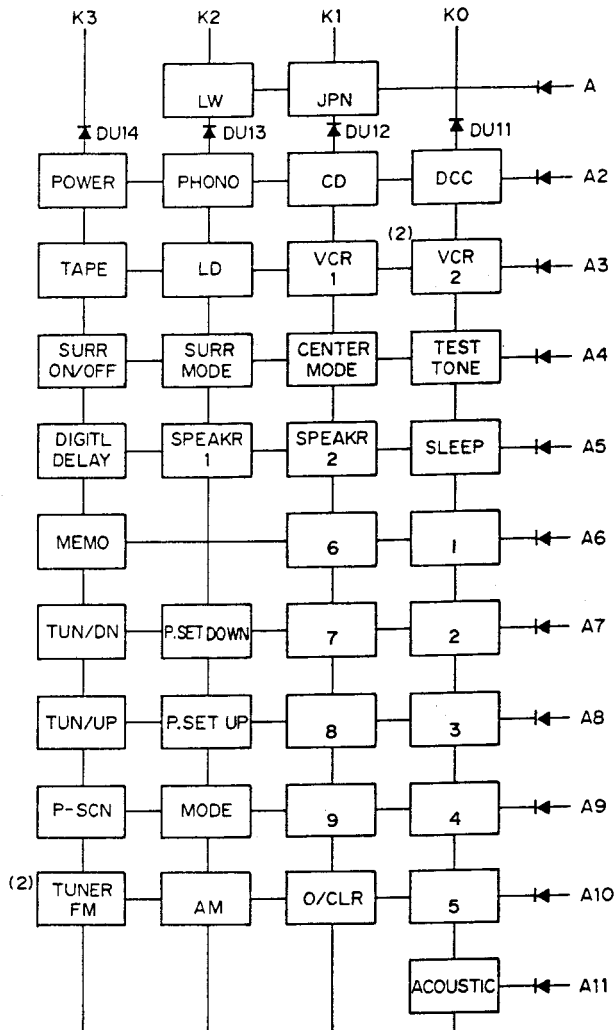

The two keys of LW JPN are lock switches for use in initial setting.

Description of keys

A: Diode switches for initial setting

LW : Tuner band select switch. When this key is ON, the AM band is unconditionally set to two bands. The indications of these bands on the FL display are MW and LW. This key is valid only in the receiver mode.

JPN : Tuner destination select switch. When this key is ON, the set is unconditionally set to the Japanese version. This key is valid only in the receiver mode.

- Initial setup recall operation: The initial setup is recalled when the POWER key is pressed or when HOLD is changed from LO to HI.

B: Momentary and lock switches (These switches are basically momentary switches unless otherwise specified.)

1 ~ 9 : Keys for use in inputting numbers in the preset number entry, clock setting or timer setting operation. In the timer setting operation, "1" is for to select ONCE and "2" is for to select DAILY.

O/CLR : Key for use in inputting "0" as well as clearing data in various modes.

SLEEP : Sleep timer mode key for to set or turn ON/OFF the sleep timer.

TUNER FM : Tuner/Band FM setting key. When this key is pressed, the TUNER input function and the FM BAND will be selected. In the amplifier mode, this key functions simply as the TUNER key.

TUN/UP : Frequency up (increase) key for in the tuner mode. Each press of the key increases the frequency by 1 step, and holding the key depressed increases it successively. This key is invalid in other modes than the tuner mode, such as the CD and LD modes.

TUN/DN : Frequency down (decrease) key with the opposite functions to the TUN/UP key above.

AM : Tuner/Band AM setting key. When LW is selected, this key selects the MW or LW band in an alternate cycle. If this key is pressed while listening to FM or playing other source, the band which was last received will be recalled (last memory), and further press of the key switches the band.

P-SCN : Key for use in automatic scanning of tuner preset channels. When this key is pressed, FL segments "PRESET SCAN" light, the set enters the preset scan mode and the preset channels will be scanned. This key is invalid in the amplifier mode.

MEMO : Key for use in setting the preset memory, timer, sleep timer, clock, etc. As the operation differs depending on the modes, refer to the description of each operation for details.

POWER

: Key for turning the power of the set ON/OFF. This is a non-lock switch which turns power ON/OFF in an alternate cycle. When the power is OFF, all of the output ports except for some special ports are in the low level, but specified input ports and the remote control input ports are accessible. The details will be described in the description of each item.

P SET UP

: Preset channel up (increase) key for in the tuner mode. Pressing this key while a preset number is displayed increases the number, and pressing this key while it is not displayed recalls P1 or the smallest preset number. This key allows to select a preset number within the same band (in FM band, it can recall only the FM preset numbers).

P SET DOWN

: Opposite operations to the above occurs.

SURR ON/OFF

: Surround mode ON/OFF key. Press to turn ON/OFF in an alternate cycle. The initial condition is OFF.

SURR MODE

: Surround mode select key. The initial condition is PRO LOGIC, and further press of the key switches to MATRIX, HALL, SIMULATED STEREO and to PRO LOGIC again.

CENTER MODE

: Center mode setting key for use in PRO LOGIC mode. The initial condition is NORMAL, and further press of the key switches to WIDE, PHANTOM and NORMAL again.

SPEAKR 1

SPEAKR 2

: Speaker system select keys. The initial conditions are OFF (with ports LO), and each press switches ON/OFF in an alternate cycle. These keys are controlled by NJU3711D, and the corresponding ports are turned ON/OFF accordingly. The conditions of these keys are also backed up by the last memory function.

TEST TONE

: When the surround mode is PRO LOGIC, this key puts the Surround IC to the test tone mode. The actual control is performed by the port expander IC (NJU3711D).

PHONO

CD

VCR 1

VCR 2

TAPE

DCC

LD

: Input selector keys, which output the corresponding serial data.

MODE

: FM stereo/mono select key. The initial condition is AUTO STEREO. The switching is based on the serial data sent to the PLL. The switching operation is cyclic. FL indicator "AUTO" lights in the AUTO STEREO mode.

DIGITL DELAY

: When the surround mode is ON, this key sets the delay time for each surround mode.

ACOUSTIC

: The combinations of the surround modes, center modes and volume levels can be stored in five memories and recalled in the acoustic mode.

* The functions of the keys are as described above. Except in the special case (service mode), if more than one key is pressed, the key pressed first is given the priority.

11. MICROPROCESSOR DATA

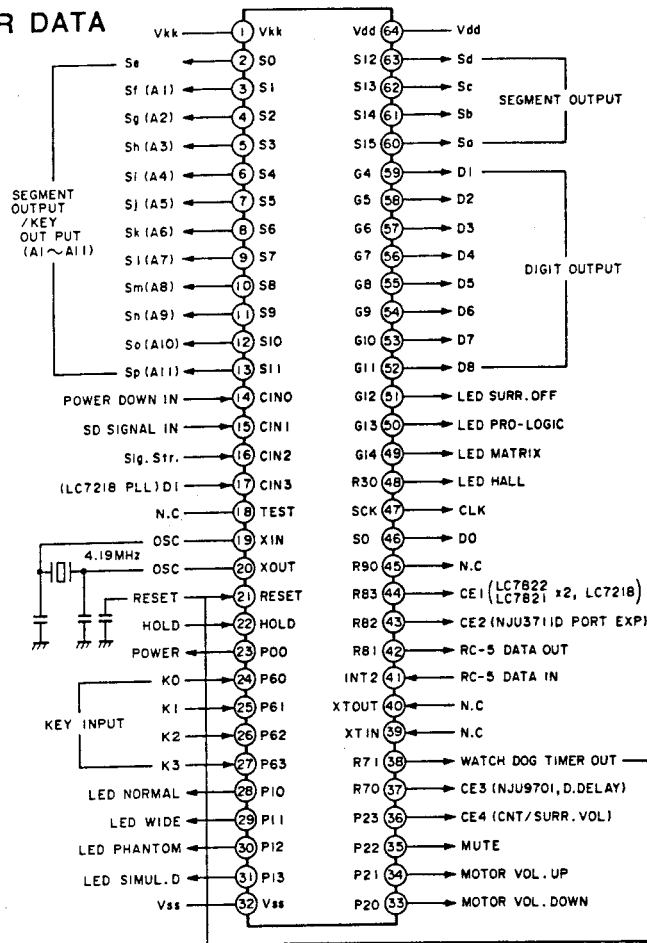

Pin Nbr.	Pin Name	I/O	Active	Function	Pin Nbr.	Pin Name	I/O	Active	Function
1	V _{kk}	—	—	-35V (FL Display Drive)	33	P20 (VR DOWN)	O	H	M. Volume Control
2	S _e (S0)	O	H	FL e-segment	34	P21 (VR UP)	O	H	M. Volume Control
3	S _f (S1)	O	H	FL f-segment/Key Switch (A1)	35	P22 (MUTE)	O	H	Mute Output
4	S _g (S2)	O	H	FL g-segment/Key Switch (A2)	36	P23 (CE4)	O	H/L	Center/Surround Volume Chip Enable
5	S _h (S3)	O	H	FL h-segment/Key Switch (A3)	37	R70 (CE3)	O	L	Digital Delay Chip Enable
6	S _i (S4)	O	H	FL i-segment/Key Switch (A4)	38	R71 (WTO)	O	L	Watch-Dog Timer
7	S _j (S5)	O	H	FL j-segment/Key Switch (A5)	39	R72 (XTAL)	—	—	N.C
8	S _k (S6)	O	H	FL k-segment/Key Switch (A6)	40	R73 (XTAL)	—	—	
9	S _l (S7)	O	H	FL l-segment/Key Switch (A7)	41	R80 (RC-5 IN)	I	L	Remote Control (RC-5) Input
10	S _m (S8)	O	H	FL m-segment/Key Switch (A8)	42	R81 (RC-5 OUT)	O	H	Remote Control (RC-5) Output
11	S _n (S9)	O	H	FL n-segment/Key Switch (A9)	43	R82 (CE2)	O	L	Port Expander Chip Enable
12	S _o (S10)	O	H	FL o-segment/Key Switch (A10)	44	R83 (CE1)	O	H	Analog Switch/PLL Chip Enable
13	S _p (S11)	O	H	FL p-segment/Key Switch (A11)	45	R90 (N.C)	—	—	N.C
14	POW. DOWN	I	L	Power Down: L	46	S0 (DO)	O	H	Serial Data
15	SD IN	I	L	SD Signal Input	47	SCK (CLK)	O	H	Serial Clock
16	SIG. IN	I	H	Signal Strength Indicator	48	R30 (LED HALL)	O	H	Surround Mode
17	DI	I	H	Serial Data Input	49	G14 (LED MTRX)	O	H	Surround Mode
18	TEST	—	—	N.C	50	G13 (LED PRO)	O	H	Surround Mode
19	X IN	—	—	Clock (4.19 MHz)	51	G12 (LED OFF)	O	H	Surround Mode
20	X OUT	—	—						
21	RESET	I	L	Reset and Watch-Dog Timer	52	G11 (D8)	O	H	Digit Output D8 Digit
22	HOLD	I	L	Hold Mode	53	G10 (D7)	O	H	Digit Output D7 Digit
23	P00 (POWER)	O	H	Relay Drive Output	54	G9 (D6)	O	H	Digit Output D6 Digit
24	P60 (K0)	I	H	Key Switch	55	G8 (D5)	O	H	Digit Output D5 Digit
25	P61 (K1)	I	H						
26	P62 (K2)	I	H						
27	P63 (K3)	I	H						
28	P10 (LED NORM)	O	L	Cent. Mode: Normal	56	G7 (D4)	O	H	Digit Output D4 Digit
29	P11 (LED WIDE)	O	L	Cent. Mode: Wide	57	G6 (D3)	O	H	Digit Output D3 Digit
30	P12 (LED PHTM)	O	L	Cent. Mode: Phantom	58	G5 (D2)	O	H	Digit Output D2 Digit
31	P13 (LED SIML)	O	L	Surr. Mode: Simulated	59	G4 (D1)	O	H	Digit Output D1 Digit
32	V _{ss}	—	—	GND	60	S15 (S _a)	O	H	FL Display a-segment
					61	S14 (S _b)	O	H	FL Display b-segment
					62	S13 (S _c)	O	H	FL Display c-segment
					63	S12 (S _d)	O	H	FL Display d-segment
					64	V _{dd}	—	—	V _{dd}

12. ELECTRICAL PARTS LIST

ASSIGNMENT OF COMMON PARTS CODES.

RESISTOR

R*** : (1) GD05 x x x 140. Carbon film fixed resistor. $\pm 5\%$ 1/4W

R*** : (2) GD05 x x x 160. Carbon film fixed resistor. $\pm 5\%$ 1/6W

① — Resistance value

Examples :

① Resistance value			
0.1 Ω ...001	10 Ω ...100	1k Ω ...102	100k Ω ...104
0.5 Ω ...005	18 Ω ...180	2.7k Ω ...272	680k Ω ...684
1 Ω ...010	100 Ω ...101	10k Ω ...103	1M Ω ...105
6.8 Ω ...068	390 Ω ...391	22k Ω ...223	4.7M Ω ...475

(Note) Please distinguish 1/4W from 1/6W by the shape of parts used actually.

C*** : CERAMIC CAP.

(1) DD1 x x x x 370. Ceramic capacitor
Disc type
Temp.coeff.P350~N1000,50V

① — Capacity value
② — Tolerance

Examples

① Tolerance (Capacity deviation)	
$\pm 0.25\text{pF}$... 0	$\pm 0.5\text{pF}$... 1
$\pm 5\%$... 5	

* Tolerance of COMMON PARTS handled here are as follows :

0.5pF~	5pF... $\pm 0.25\text{pF}$
6pF~	10pF... $\pm 0.5\text{pF}$
12pF~	560pF... $\pm 5\%$

② Capacity value

0.5pF...005	3pF...030	100pF...101
1pF...010	10pF...100	220pF...221
1.5pF...015	47pF...470	560pF...561

C*** : CERAMIC CAP.

(1) DK16 x x x x 300. High dielectric constant ceramic capacitor
Disc type
Temp.chara. 2B4, 50V

① — Capacity value

Examples

② Capacity value	
100pF...101	1000pF...102
470pF...471	2200pF...222

C*** : ELECTROLY CAP. (E), FILM CAP. (F)

(1) EA x x x x x 10. Electrolytic capacitor
One-way lead type. Tolerance $\pm 20\%$

① — Working voltage
② — Capacity value

Examples

① Capacity value		
0.1 μF ...104	4.7 μF ...475	100 μF ...107
0.33 μF ...334	10 μF ...106	330 μF ...337
1 μF ...105	22 μF ...226	1100 μF ...118
		2200 μF ...228

② Working voltage

6.3V...006	25V...025
10V...010	35V...035
16V...016	50V...050

(2) DF15 x x x 350. Plastic film capacitor
One-way type. Mylar $\pm 5\%$ 50V

① — Capacity value

Examples

① Capacity value	
0.001 μF (1000pF)...102	0.1 μF ...104
0.0018 μF ...182	0.56 μF ...564
0.01 μF ...103	1 μF ...105
0.015 μF ...153	

NOTE : The above CODES (R***, R***, C***, C*** and C***) are omitted on the schematic diagram in some case.

On the occasion, be confirmed the common parts on the parts list.

NOTE ON SAFETY FOR FUSIBLE RESISTOR:

The suppliers and their type numbers of fusible resistors are as follows;

1. KOA Corporation

Part No.	Type No.	Description
NH05 x x x 140	RF25S x x x x Ω J	($\pm 5\%$ 1/4W)
NH05 x x x 120	RF50S x x x x Ω J	($\pm 5\%$ 1/2W)
NH85 x x x 110	RF73B2A x x x x Ω J	($\pm 5\%$ 1/10W)
NH95 x x x 140	RF73B2E x x x x Ω J	($\pm 5\%$ 1/4W)

* Resistance value Resistance value(0.1-10k Ω)

2. Matsushita Electronic Components Co., Ltd

Part No.	Type No.	Description
NF05 x x x 140	ERD-2FCJ x x x	($\pm 5\%$ 1/4W)
RF05 x x x 140		
NF02 x x x 140	ERD-2FCG x x x	($\pm 2\%$ 1/4W)
RF02 x x x 140		

* Resistance value * Resistance value

Examples;

* Resistance value

0.1 Ω ...001	10 Ω ...100	1k Ω ...102	100k Ω ...104
0.5 Ω ...005	18 Ω ...180	2.7k Ω ...272	680k Ω ...684
1 Ω ...010	100 Ω ...101	10k Ω ...103	1M Ω ...105
6.8 Ω ...068	390 Ω ...391	22k Ω ...223	4.7M Ω ...475

[U] : for U. S. A.
 [K] : for Far East

POS.NO	VERSION	PART NO. (FOR EUROPE)	DESCRIPTION	PART NO. (FOR U/K)
PB04			PB04-BACK UP TRANF / OUTLET CIRCUIT BOARD BACK UP TRANSF / OUTLET PCB	WA183J2030
CB01		4822 122 30043	Ceramic 0.01 μ F +80% -20% 50V	DK18103310
CB03		4822 122 33276	Ceramic 0.01 μ F \pm 20%	DK17103840
CB04	/02B/02G	4822 122 30043	Ceramic 0.01 μ F +80% -20% 50V	DK18103310
CB05	/02B/02G	4822 122 30043	Ceramic 0.01 μ F +80% -20% 50V	DK18103310
			PB04-CAPACITORS (COMMON)	
C***			Electrolytic capacitor, \pm 20% : CB02	
			PB04-RESISTORS	
RB03	U		2.2M Ω \pm 10% 1/2W	RC10225920
RB04		4822 053 11331	330 Ω \pm 5% 2W	GA05331020
			PB04-RESISTORS (COMMON)	
R***			Carbon film fixed resistor, \pm 5% 1/6W : RB01, RB02	
			PB04-SEMICONDUCTORS	
DB01		4822 130 80839	Diode S5688G	HD20029050
DB02		4822 130 80839	Diode S5688G	HD20029050
DB03		4822 130 80839	Diode S5688G	HD20029050
DB04		4822 130 83395	Zener RD20F B3 20V	HD32001060
QB01		4822 130 42298	Transistor 2SC536SP, etc.	HT30001000
			PB04-MISCELLANEOUS	
▲FB01	/02B/02G U	4822 253 40166	Fuse T2.5A 250V Fuse 5.0A 125V	FS10250850 FS10500300
▲JB03	/02B/02G U/K	4822 267 31687	Jack, AC Outlet Jack, AC Outlet	YJ04002010 YJ04002030
▲LB01	U K		Power Transformer, Buck-up Power Transformer, Buck-up	TS13516030 TS13516050
▲LB02	/02B/02G U	4822 146 21757	Power Transformer, Buck-up	TS13516090
	/02B/02G /K	4822 280 20354 4822 280 80773	Relay Relay	LY10240140 LY10240240
▲SB01	K		Slide Switch	SS0202124R
			PE04--TONE AMP / BALANCE VOLUME CIRCUIT BOARD	
PE04			TONE AMP / BALANCE VOLUME PCB	WA183J3020
			PE04--CAPACITORS	
CD01		4822 122 30043	Ceramic 0.01 μ F +80% -20% 50V	DK18103310
CD02		4822 122 30043	Ceramic 0.01 μ F +80% -20% 50V	DK18103310
CE03		4822 124 21894	Elect 10 μ F 16V	EJ10601610
CE04		4822 124 21894	Elect 10 μ F 16V	EJ10601610
CE09		4822 124 23056	Elect 47 μ F 16V	EJ47601610
CE10		4822 124 23056	Elect 47 μ F 16V	EJ47601610
CE15		4822 124 23055	Elect 22 μ F 16V	EJ22601610
CE16		4822 124 23055	Elect 22 μ F 16V	EJ22601610
CE17		4822 124 40786	Elect 2.2 μ F 50V	EJ22505010
CE18		4822 124 40786	Elect 2.2 μ F 50V	EJ22505010
CE19		4822 124 21895	Elect 0.22 μ F 50V	EJ22405010
CE20		4822 124 21895	Elect 0.22 μ F 50V	EJ22405010
CE25		4822 122 30043	Ceramic 0.01 μ F +80% -20% 50V	DK18103310
CE26		4822 122 30043	Ceramic 0.01 μ F +80% -20% 50V	DK18103310
CE27		4822 122 30043	Ceramic 0.01 μ F +80% -20% 50V	DK18103310
			PE04-CAPACITORS (COMMON)	
C***			High dielectric constant ceramic capacitor, \pm 10% 50V : CE01, CE02, CE21, CE22	

POS.NO	VERSION	PART NO. (FOR EUROPE)	DESCRIPTION	PART NO. (FOR U/K)
C***			Electrolytic capacitor, $\pm 20\%$: CE17, CE23, CE24	
C***			Plastic film capacitor, $\pm 5\%$ 50V : CE05~CE08, CE11~CE14	
RE19		4822 101 21242	10K Ω (E), Variable Bass	RM01030910
RE20		4822 101 21242	10K Ω (E), Variable Treble	RM01030910
RE31		4822 050 21021	100 Ω $\pm 5\%$ 1/4W	GG05101140
RE32		4822 050 21021	100 Ω $\pm 5\%$ 1/4W	GG05101140
RE39		4822 100 12064	100K Ω (MN), Variable Balance	RM01041560
R***			Carbon film fixed resistor, $\pm 5\%$ 1/6W : RE01~RE18, RE21~RE30, RE33~RE38	
DD01		4822 130 80317	Zener RD5.1JB2 / MTZJ5.1B	HD30511000
QD01		4822 209 30193	IC LB1641	HC10279030
QE01		4822 130 42298	Transistor 2SC536SP, etc.	HT30001000
QE02		4822 130 42298	Transistor 2SC536SP, etc.	HT30001000
QE03		4822 130 61892	Transistor 2SD2144S (U, V)	HT421442A0
QE04		4822 130 61892	Transistor 2SD2144S (U, V)	HT421442A0
QE05		4822 209 73064	IC NJM2068DD	HC10053090
QE06		4822 130 42594	Transistor, Digital DTC144ES	BA20002000
QE07		4822 130 42682	Transistor, Digital DTA144ES	BA10002000
SE01		4822 276 13449	Push Switch, Bass EQ	SP02012090
PG04			PG04-MASTER VOLUME CIRCUIT BOARD MASTER VOLUME PCB	WA183J3030
CG71		4822 122 30043	Ceramic Cap. 0.01 μ F +80% -20% 50V	DK18103310
RG71		4822 100 12065	Variable Resistor 100K Ω (B) x 2, Motor	RY01040220
PT04			PT04-TRANSFORMER CIRCUIT BOARD TRANSFORMER PCB	WA183J3050
FT01	K		Fuse T2.5A 250V	FS10250850
FT02	K		Fuse T2.5A 250V	FS10250850
PU04			PU04-U-PROCESSOR / SWITCH CIRCUIT BOARD U-PROCESSOR / SWITCH PCB	WA183J3010
CU01		4822 124 22318	Elect 10 μ F 16V	EG10601650
CU02		4822 124 23295	Big Elect 0.022F 5.5V	EX22300510
CU03		4822 124 80651	Elect 100 μ F 6.3V	EG10700650
CU04		4822 122 40586	Ceramic 0.01 μ F $\pm 20\%$ 16V	DA17103110
CU06		4822 124 80651	Elect 100 μ F 6.3V	EG10700650
CU07		4822 124 22318	Elect 10 μ F 16V	EG10601650
CU08		4822 124 80774	Elect 10 μ F 25V	EG10602550
CU09		4822 122 40586	Ceramic 0.01 μ F $\pm 20\%$ 16V	DA17103110
CU10		4822 122 40586	Ceramic 0.01 μ F $\pm 20\%$ 16V	DA17103110
CU11		4822 124 41604	Elect 0.1 μ F 50V	EG10405010
CU12		4822 124 80651	Elect 100 μ F 6.3V	EG10700650
GU01		4822 111 91399	100K Ω x 4, Array	BW05104080
GU02		4822 111 92152	10K Ω x 6, Array	BW05103230
GU03		4822 111 92152	10K Ω x 6, Array	BW05103230
GU04		4822 111 91399	100K Ω x 4, Array	BW05104080

POS.NO	VERSION	PART NO. (FOR EUROPE)	DESCRIPTION	PART NO. (FOR U/K)
R***			PU04-RESISTORS (COMMON) Carbon film fixed resistor, ±5% 1/6W : RU01~RU12	
			PU04-SEMICONDUCTORS	
DU01 }	/02B/02G	4822 130 33305	Diode 1SS176, etc.	HD20002000
DU14		4822 130 33305	Diode 1SS176, etc.	HD20002000
DU17		4822 130 33305	Diode 1SS176, etc.	HD20002000
DU19 }		4822 130 33305	Diode 1SS176, etc.	HD20002000
DU26				
DU27 }		4822 130 80326	L.E.D. LT3D8B (RED)	HL10062320
DU31				
DU32		4822 130 81715	L.E.D. LT3K44B (GRN)	HI10095320
DU33		4822 130 80326	L.E.D. LT3D8B (RED)	HI10062320
DU34		4822 130 80326	L.E.D. LT3D8B (RED)	HI10062320
DU35		4822 130 80326	L.E.D. LT3D8B (RED)	HI10062320
DU36		4822 130 33305	Diode 1SS176, etc.	HD20002000
QU01		4822 209 32698	Microprocessor TMP47C1670AN	HU10086050
QU02		4822 209 32697	IC 78LR05L	HC10317030
QU03	4822 214 52009	Photo Unit GP1U58XP	HW10026320	
QU04	4822 130 42594	Transistor, Digital DTC144ES	BA20002000	
QU05	4822 130 42682	Transistor, Digital DTA144ES	BA10002000	
QU06	4822 130 42594	Transistor, Digital DTC144ES	BA20002000	
QU07	4822 130 42682	Transistor, Digital DTA144ES	BA10002000	
			PU04-MISCELLANEOUS	
SU01 }	4822 276 20508	Push Switch	SP01011280	
SU35				
SU51	4822 276 20508	Push Switch, Power / Standby	SP01011280	
VU01	4822 130 91278	Display Unit, FIP7JM9	HQ30810060	
XU01	4822 242 72194	Ceramic Resonator, 4.19MHz	FQ04194020	
			PV04-FUNC / MAIN / SUPP / SPK CIRCUIT BOARD	
PV04			FUNC / MAIN / SUPP / SPK PCB	WA183J1000
			PV04-CAPACITORS	
CN03	4822 124 23055	Elect 22µF 16V	EJ22601610	
CN04	4822 122 30043	Ceramic 0.01µF +80% -20% 50V	DK18103310	
CN10	4822 124 23053	Elect 1µF 50V	EJ10505010	
CN53	4822 124 23055	Elect 22µF 16V	EJ22601610	
CV01 }	4822 122 40617	Ceramic 0.1µF +80% -20% 50V	DK38104010	
CV04				
CV06	4822 124 21894	Elect 10µF 16V	EJ10601610	
CV07	4822 122 30043	Ceramic 0.01µF +80% -20% 50V	DK18103310	
CV08	4822 122 30043	Ceramic 0.01µF +80% -20% 50V	DK18103310	
C403	4822 124 21894	Elect 10µF 16V	EJ10601610	
C404	4822 124 21894	Elect 10µF 16V	EJ10601610	
C405	4822 124 23055	Elect 22µF 16V	EJ22601610	
C406	4822 124 23055	Elect 22µF 16V	EJ22601610	
C413	4822 124 21894	Elect 10µF 16V	EJ10601610	
C414	4822 124 21894	Elect 10µF 16V	EJ10601610	
C419	4822 122 30043	Ceramic 0.01µF +80% -20% 50V	DK18103310	
C420	4822 122 30043	Ceramic 0.01µF +80% -20% 50V	DK18103310	
C421	4822 122 30043	Ceramic 0.01µF +80% -20% 50V	DK18103310	
C703	4822 124 21894	Elect 10µF 16V	EJ10601610	
C704	4822 124 21894	Elect 10µF 16V	EJ10601610	
C705	5322 122 32072	Ceramic 33pF ±5% 50V	DD15330300	
C706	5322 122 32072	Ceramic 33pF ±5% 50V	DD15330300	
C711	4822 126 10797	Ceramic 10pF ±0.5pF 500V	DD11100560	
C712	4822 126 10797	Ceramic 10pF ±0.5pF 500V	DD11100560	
C713	4822 122 40367	Ceramic 7pF ±0.5pF 50V	DD11070300	
C714	4822 122 40367	Ceramic 7pF ±0.5pF 50V	DD11070300	
C717 }	5322 122 32265	Ceramic 100pF ±5% 500V	DD15101560	
C720				

POS.NO	VERSION	PART NO. (FOR EUROPE)	DESCRIPTION	PART NO. (FOR U/K)
C721 }		4822 124 21895	Elect 0.22 μ F 50V	EJ22405010
C724		4822 124 21894	Elect 10 μ F 16V	EJ10601610
C726		4822 124 80649	Elect 10 μ F 100V	EJ10610010
C727		4822 124 80649	Elect 10 μ F 100V	EJ10610010
C728				
C741 }	/02B/02G	4822 122 30043	Ceramic 0.01 μ F +80% -20% 50V	DK18103310
C744		4822 124 21894	Elect 10 μ F 16V	EJ10601610
C753		4822 124 21894	Elect 10 μ F 16V	EJ10601610
C754		4822 124 21894	Elect 10 μ F 16V	EJ10601610
C759		4822 122 31188	Ceramic 3pF \pm 0.25pF 50V	DD10030300
C760		4822 122 31188	Ceramic 3pF \pm 0.25pF 50V	DD10030300
C761		4822 124 23626	Elect 100 μ F 63V	EA10706310
C762		4822 124 80649	Elect 10 μ F 100V	EA10610010
C763		4822 124 23626	Elect 100 μ F 63V	EA10706310
C764		4822 124 80649	Elect 10 μ F 100V	EA10610010
C765				
C768		4822 124 21895	Elect 0.22 μ F 50V	EJ22405010
C801		4822 126 12453	Ceramic 0.01 μ F +80% -20% 500V	DK18103560
▲C802	U/K	4822 124 42407	Elect 8200 μ F 56V	EB82805650
	/02B/02G		Elect 8200 μ F 63V	EB82806340
▲C803	U/K	4822 124 42407	Elect 8200 μ F 56V	EB82805650
	/02B/02G		Elect 8200 μ F 63V	EB82806340
C804		4822 122 30043	Ceramic 0.01 μ F +80% -20% 50V	DK18103310
C805		4822 122 30043	Ceramic 0.01 μ F +80% -20% 50V	DK18103310
C810		4822 124 21894	Elect 10 μ F 16V	EJ10601610
C811		4822 124 21894	Elect 10 μ F 16V	EJ10601610
C812		4822 124 21894	Elect 10 μ F 16V	EJ10601610
C813		4822 124 40786	Elect 2.2 μ F 50V	EJ22505010
			PV04-CAPACITORS (COMMON)	
C***			High dielectric constant ceramic capacitor, \pm 10% 50V : (CV09-CV29 [/02B/02G]), C401, C402, (C407, C408 [/02B/02G]), C411, C412, C415, C416, C701, C702, C709, C710, C751, C752	
C***			Electrolytic capacitor, \pm 20% : CN05, CN07, C417, C418, C707, C708, C725, C757, C758, C761, C763, C806-C809	
C***			Plastic film capacitor, \pm 5% 50V : C409, C410	
			PV04-RESISTORS	
RN01		4822 052 10102	1K Ω \pm 5% 1/6W	GG05102160
RN02		4822 052 10102	1K Ω \pm 5% 1/6W	GG05102160
RN13		4822 052 10109	10 Ω \pm 5% 1/6W	GG05100160
RN14		4822 052 10109	10 Ω \pm 5% 1/6W	GG05100160
RN15		4822 052 10109	10 Ω \pm 5% 1/6W	GG05100160
RN51		4822 052 10102	1K Ω \pm 5% 1/6W	GG05102160
RN52		4822 052 10102	1K Ω \pm 5% 1/6W	GG05102160
RN61		4822 052 10109	10 Ω \pm 5% 1/6W	GG05100160
RV38		4822 111 31001	330 Ω \pm 5% 1/6W	GG05331160
RV40		4822 111 31001	330 Ω \pm 5% 1/6W	GG05331160
R417		4822 050 21021	100 Ω \pm 5% 1/4W	GG05101140
R418		4822 050 21021	100 Ω \pm 5% 1/4W	GG05101140
R713		4822 050 26809	68 Ω \pm 5% 1/6W	GG05680160
R714		4822 050 26809	68 Ω \pm 5% 1/6W	GG05680160
R719		4822 100 11386	1K Ω , Trimming	RA01020780
R720		4822 100 11386	1K Ω , Trimming	RA01020780
R725 }		4822 050 26809	68 Ω \pm 5% 1/6W	GG05680160
R730				
R731		4822 053 10221	220 Ω \pm 5% 1W	GA05221010
R732		4822 053 10221	220 Ω \pm 5% 1W	GA05221010
R733 }		4822 052 10229	22 Ω \pm 5% 1/6W	GG05220160
R736				
R737		4822 116 82049	0.18 Ω x 2 3W	BZ10182010
R738		4822 116 82049	0.18 Ω x 2 3W	BZ10182010
R739		4822 050 26809	68 Ω \pm 5% 1/6W	GG05680160
R740		4822 050 26809	68 Ω \pm 5% 1/6W	GG05680160
R743		4822 053 11109	10 Ω \pm 5% 2W	GA05100020
R744		4822 053 11109	10 Ω \pm 5% 2W	GA05100020

POS.NO	VERSION	PART NO. (FOR EUROPE)	DESCRIPTION	PART NO. (FOR U/K)
R745		4822 053 10472	4.7K Ω $\pm 5\%$ 1W	GA05472010
R747		4822 053 11331	330 Ω $\pm 5\%$ 2W	GA05331020
R748		4822 053 11331	330 Ω $\pm 5\%$ 2W	GA05331020
R763		4822 052 10101	100 Ω $\pm 5\%$ 1/6W	GG05101160
R764		4822 052 10101	100 Ω $\pm 5\%$ 1/6W	GG05101160
R771		4822 113 80363	0.22 Ω $\pm 10\%$ 3W	GO10222030
R772		4822 113 80363	0.22 Ω $\pm 10\%$ 3W	GO10222030
R773		4822 053 11109	10 Ω $\pm 5\%$ 2W	GA05100 20
R774		4822 053 11109	10 Ω $\pm 5\%$ 2W	GA05100 20
▲ R801		4822 116 60306	1 Ω $\pm 5\%$ 1/2W, Fusible	NH05010120
▲ R802		4822 116 60306	1 Ω $\pm 5\%$ 1/2W, Fusible	NH05010120
▲ R803		4822 116 60306	1 Ω $\pm 5\%$ 1/2W, Fusible	NH05010120
R805		4822 053 10569	56 Ω $\pm 5\%$ 1W	GA05560010
▲ R806		4822 116 60312	4.7 Ω $\pm 5\%$ 1/2W, Fusible	NH05047120
▲ R807		4822 117 10204	47 Ω $\pm 5\%$ 1/2W, Fusible	NH05470120
R808		4822 053 11102	100 Ω $\pm 5\%$ 2W	GA05101020
▲ R809		4822 116 60312	4.7 Ω $\pm 5\%$ 1/2W, Fusible	NH05047120
			PV04-RESISTORS (COMMON)	
			Carbon film fixed resistor, $\pm 5\%$ 1/6W :	
			RN03~RN12, RN17~RN25, RN53~RN60, RN71, RN72, RN73, RV05, RV06, RV09, RV10, RV15, RV16, RV19~RV37, R401~R416, R701~R712, R715~R718, R721~R724, R741, R742, R746, R749, R751~R756, R759~R762, R765, R766, R804, R810, R811	
			PV04-SEMICONDUCTORS	
DN01		4822 130 80837	Diode HSS81TD	HD20027010
DN02		4822 130 80837	Diode HSS81TD	HD20027010
DN03		4822 130 33305	Diode 1SS176, etc.	HD20002000
DN04		4822 130 33305	Diode 1SS176, etc.	HD20002000
DN05		4822 130 33305	Diode 1SS176, etc.	HD20002000
DN51		4822 130 80837	Diode HSS81TD	HD20027010
DN52		4822 130 80837	Diode HSS81TD	HD20027010
DN53		4822 130 33305	Diode 1SS176, etc.	HD20002000
DN71		4822 126 90007	Varistor PTH9M04BC222TS	HP00033240
DV02		4822 130 33305	Diode 1SS176, etc.	HD20002000
DV03		4822 130 33305	Diode 1SS176, etc.	HD20002000
D701		4822 130 80273	Zener RD8.2JB2 / MTZJ8.2C	HD30821000
D702		4822 130 80322	Zener RD15JB3 / MTZJ15A	HD31501000
D703				
?		4822 130 33305	Diode 1SS176, etc.	HD20002000
D706				
D801				
?		4822 130 33864	Varistor 30D-2	HD20003010
D804				
▲ D805				
?		4822 130 80839	Diode S5688G	HD20029050
▲ D811				
D812		4822 130 80322	Zener RD15JB3 / MTZJ15A	HD31501000
D813		4822 130 81729	Zener MTZJ33D	HD33301000
D814		4822 130 80273	Zener RD8.2JB2 / MTZJ8.2C	HD30821000
QN01		4822 130 43233	Transistor 2SC2240 (GR, BL)	HT322402A0
QN02		4822 130 43233	Transistor 2SC2240 (GR, BL)	HT322402A0
QN03		4822 130 42951	Transistor 2SA970 (GR, BL)	HT109702A0
QN04		4822 130 43312	Transistor 2SC3312 (R, S)	HT333122A0
QN05		4822 130 43312	Transistor 2SC3312 (R, S)	HT333122A0
QN06		4822 209 83312	IC TA7317P	HC10042050
QN51		4822 130 43233	Transistor 2SC2240 (GR, BL)	HT322402A0
QN52		4822 130 43233	Transistor 2SC2240 (GR, BL)	HT322402A0
QN53		4822 130 42951	Transistor 2SA970 (GR, BL)	HT109702A0
QN71		4822 130 60766	Transistor, Digital DTA114ES	BA10001000
QN72		4822 130 61892	Transistor 2SD2144S (U, V)	HT421442A0
QV01		4822 209 72748	IC LC7821	HC10228030
QV02		4822 209 73321	IC LC7822	HC10241030
QV03		4822 130 42594	Transistor, Digital DTC144ES	BA20002000
QV04		4822 130 42682	Transistor, Digital DTA144ES	BA10002000
QV07		4822 130 61892	Transistor 2SD2144S (U, V)	HT421442A0
QV08		4822 130 61892	Transistor 2SD2144S (U, V)	HT421442A0
Q401		4822 209 83631	IC NJM4558DD	HC10008090

POS.NO	VERSION	PART NO. (FOR EUROPE)	DESCRIPTION	PART NO. (FOR U/K)
▲ Q701		4822 130 42999	Transistor 2SA1145 (O, Y)	HT111452A0
▲ Q702		4822 130 42999	Transistor 2SA1145 (O, Y)	HT111452A0
▲ Q703		4822 130 43283	Transistor 2SC2705 (O, Y)	HT327052A0
▲ Q704		4822 130 43283	Transistor 2SC2705 (O, Y)	HT327052A0
▲ Q705		4822 130 60117	Transistor 2SC3419	HT334191Y0
▲ Q706		4822 130 60117	Transistor 2SC3419	HT334191Y0
▲ Q707		4822 130 62335	Transistor 2SD2033 (E)	HT420331E0
▲ Q708		4822 130 62335	Transistor 2SD2033 (E)	HT420331E0
▲ Q709		4822 130 62334	Transistor 2SB1353 (E)	HT213531E0
▲ Q710		4822 130 62334	Transistor 2SB1353 (E)	HT213531E0
▲ Q711		4822 130 43306	Transistor 2SC3182 (R, O)	HT331822A0
▲ Q712		4822 130 43306	Transistor 2SC3182 (R, O)	HT331822A0
▲ Q713		4822 130 43019	Transistor 2SA1265 (R, O)	HT112652A0
▲ Q714		4822 130 43019	Transistor 2SA1265 (R, O)	HT112652A0
▲ Q715		4822 209 83732	IC AN7062N	HC10066020
▲ Q751		4822 209 32696	IC STK401-110	HC10312030
▲ Q801		4822 209 61848	IC NJM7815FA	HC38915090
▲ Q802		4822 209 31631	IC NJM7805FA	HC38905090
▲ Q803		4822 209 83828	IC NJM7915FA	HC3991509F
PV04-MISCELLANEOUS				
LN01		4822 280 70354	Relay 24MBU-510	LY20240310
LN02		4822 280 70354	Relay 24MBU-510	LY20240310
LN03		4822 280 20501	Relay MR62-24SR	LY20240410
LN51		4822 280 70354	Relay 24MBU-510	LY20240310
L701		4822 157 70022	Air Coil	ML08010030
L702		4822 157 70022	Air Coil	ML08010030
L751		4822 157 70022	Air Coil	ML08010030
L752		4822 157 70022	Air Coil	ML08010030
JV01		4822 265 30457	Terminal, 6P RCA	YT02060240
JV02		4822 265 30457	Terminal, 6P RCA	YT02060240
JV03		4822 265 30457	Terminal, 6P RCA	YT02060240
JV04		4822 265 30397	Terminal, 4P RCA	YT02040610
JV05		4822 266 30274	Terminal, 2P RCA	YT02020550
J401		4822 267 30741	Terminal, 2P RCA	YT02020490
J701		4822 290 61179	Terminal, SPK	YT01080120
PW04-HEADPHONE CIRCUIT BOARD				
PW04			HEADPHON PCB	WA183J3040
CW01		4822 122 40617	Ceramic 01μF 50V	DD38104010
JW02	/02B/K/U /02G/K	4822 267 31691 4822 267 31692	Jack, Headphone (BLK) Jack, Headphone (GLD)	YJ01003870 YJ01003880
P104-FM FRONT END / FM / AM IF CIRCUIT BOARD				
P104			FM FRONT END / FM / AM IF PCB	WA183J2010
P104-CAPACITORS				
CA01		4822 125 60185	Trimming 20pF	CT12000200
CA02		4822 122 40306	Ceramic 0.047μF +80% -20% 50V	DK18473310
CA03		4822 122 31823	Ceramic 15pF ±5% 50V	DD15150300
CA04		5322 121 54128	Film 390pF ±5% 50V	DF55391090
CA05		4822 122 31205	Ceramic 47pF ±5% 50V	DD15470300
CA06		4822 122 30043	Ceramic 0.01μF +80% -20% 50V	DK18103310
CA07	/02B/02G	4822 122 30043	Ceramic 0.01μF +80% -20% 50V	DK18103310
CA08	/02B/02G	4822 125 60185	Trimming 20pF	CT12000200
CA09	/02B/02G	4822 122 31823	Ceramic 15pF ±5% 50V	DD15150300
CA11	/02B/02G	4822 122 31349	Ceramic 68pF ±5% 50V	DD15680300
CA12	/02B/02G	4822 122 10367	Ceramic 150pF ±5% 50V	DD15151300
CA13	/02B/02G	4822 122 30043	Ceramic 0.01μF +80% -20% 50V	DK18103310
CA14	/02B/02G	4822 122 30043	Ceramic 0.01μF +80% -20% 50V	DK18103310
CA15		4822 122 30043	Ceramic 0.01μF +80% -20% 50V	DK18103310
CA18		4822 124 21894	Elect 10μF 16V	EJ10601610
CF01		4822 124 23053	Elect 1μF 50V	EJ10505010
CF02		4822 124 23053	Elect 1μF 50V	EJ10505010
CL04		4822 124 21894	Elect 10μF 16V	EJ10601610
CL05		4822 124 21894	Elect 10μF 16V	EJ10601610
CL06		4822 124 21894	Elect 10μF 16V	EJ10601610
CL13		4822 122 40617	Ceramic 0.1μF +80% -20% 50V	DD38104010

POS.NO	VERSION	PART NO. (FOR EUROPE)	DESCRIPTION			PART NO. (FOR U/K)
CM01		4822 124 23053	Elect	1 μ F	50V	EJ10505010
CM02		4822 124 23053	Elect	1 μ F	50V	EJ10505010
CM04		4822 124 23053	Elect	1 μ F	50V	EJ10505010
CM06		4822 124 23053	Elect	1 μ F	50V	EJ10505010
CM08		4822 124 21895	Elect	0.22 μ F	50V	EJ22405010
CM10		4822 124 23053	Elect	1 μ F	50V	EJ10505010
CM15		4822 122 31205	Ceramic	47pF	\pm 5% 50V	DD15470300
CM18		4822 124 23053	Elect	1 μ F	50V	EJ10505010
CM22		4822 124 21895	Elect	0.22 μ F	50V	EJ22405010
CM24		4822 122 30043	Ceramic	0.01 μ F	+80% -20% 50V	DK18103310
CM27		4822 122 30043	Ceramic	0.01 μ F	+80% -20% 50V	DK18103310
CM28		4822 124 23053	Elect	1 μ F	50V	EJ10505010
CW51	/02B/02G	4822 122 30103	Ceramic	0.022 μ F	+80% -20% 50V	DK18223310
CW52	/02B/02G	4822 122 30103	Ceramic	0.022 μ F	+80% -20% 50V	DK18223310
CW53	/02B/02G	4822 122 30103	Ceramic	0.022 μ F	+80% -20% 50V	DK18223310
C201		4822 122 30043	Ceramic	0.01 μ F	+80% -20% 50V	DK18103310
C202		4822 122 30043	Ceramic	0.01 μ F	+80% -20% 50V	DK18103310
C203		4822 122 40306	Ceramic	0.047 μ F	+80% -20% 50V	DK18473310
C204		4822 124 21894	Elect	10 μ F	16V	EJ10601610
C205		4822 122 40306	Ceramic	0.047 μ F	+80% -20% 50V	DK18473310
C206		4822 124 21894	Elect	10 μ F	16V	EJ10601610
C208		4822 122 40306	Ceramic	0.047 μ F	+80% -20% 50V	DK18473310
C209		4822 124 23053	Elect	1 μ F	50V	EJ10505010
C211		4822 124 23053	Elect	1 μ F	50V	EJ10505010
C213		4822 124 21899	Elect	4.7 μ F	25V	EJ47502510
C214		4822 124 21894	Elect	10 μ F	16V	EJ10601610
C215		4822 122 40306	Ceramic	0.047 μ F	+80% -20% 50V	DK18473310
C217		4822 122 30043	Ceramic	0.01 μ F	+80% -20% 50V	DK18103310
C218		4822 122 30043	Ceramic	0.01 μ F	+80% -20% 50V	DK18103310
C219	U/K	4822 122 30043	Ceramic	0.01 μ F	+80% -20% 50V	DK18103310
C222		4822 122 30043	Ceramic	0.01 μ F	+80% -20% 50V	DK18103310
C223		4822 122 31205	Ceramic	47pF	\pm 5% 50V	DD15470300
C311		4822 124 21894	Elect	10 μ F	16V	EJ10601610
C312		4822 124 21894	Elect	10 μ F	16V	EJ10601610
C501		4822 122 31205	Ceramic	47pF	\pm 5% 50V	DD15470300
C502		4822 122 31205	Ceramic	47pF	\pm 5% 50V	DD15470300
C504		4822 122 30043	Ceramic	0.01 μ F	+80% -20% 50V	DK18103310
C505		4822 124 23053	Elect	1 μ F	50V	EJ10505010
C507		4822 122 30043	Ceramic	0.01 μ F	+80% -20% 50V	DK18103310
C511		4822 122 30043	Ceramic	0.01 μ F	+80% -20% 50V	DK18103310
C512		4822 122 30043	Ceramic	0.01 μ F	+80% -20% 50V	DK18103310
C601		4822 124 21894	Elect	10 μ F	16V	EJ10601610
C602		4822 124 21894	Elect	10 μ F	16V	EJ10601610
C612		4822 124 21894	Elect	10 μ F	16V	EJ10601610
C617		4822 124 21894	Elect	10 μ F	16V	EJ10601610
C618		4822 124 23055	Elect	22 μ F	16V	EJ22601610
C619		4822 124 21894	Elect	10 μ F	16V	EJ10601610
C621		4822 124 21894	Elect	10 μ F	16V	EJ10601610
C622		4822 124 21894	Elect	10 μ F	16V	EJ10601610
C624		4822 124 21894	Elect	10 μ F	16V	EJ10601610
C625		4822 124 21894	Elect	10 μ F	16V	EJ10601610
C636		4822 124 21899	Elect	4.7 μ F	25V	EJ47502510
C637		4822 124 21899	Elect	4.7 μ F	25V	EJ47502510
C640		4822 124 21895	Elect	0.22 μ F	50V	EJ22405010
C641		4822 124 21894	Elect	10 μ F	16V	EJ10601610
C642		4822 124 21894	Elect	10 μ F	16V	EJ10601610
C653		4822 124 21895	Elect	0.22 μ F	50V	EJ22405010
C656		4822 122 30043	Ceramic	0.22 μ F	+80% -20% 50V	DK18103310
C657		4822 124 21895	Elect	0.22 μ F	50V	EJ22405010
C665		4822 122 30043	Ceramic	0.01 μ F	+80% -20% 50V	DK18103310
			P104-CAPACITORS (COMMON)			
C***			Ceramic capacitors, 50V :			
			C210			
C***			High dielectric constant ceramic capacitors, \pm 5% 50V :			
			CA17, CF05, CF06, CM03, CM05, CM07, CM09, CM11, CM20, C509, C510, C608, C610, C629, C645, C652, C661, C662			
C***			Electrolytic capacitor, \pm 20% :			
			CF03, CF04, CL01, CL02, CL03, CL07-CL12, C207, C216, C220, C503, C508, C623, C628, C647, C655, C660, C663, C664,			

POS.NO	VERSION	PART NO. (FOR EUROPE)	DESCRIPTION	PART NO. (FOR U/K)
C***			Plastic film capacitor, ±5% 50V : CA15, CA16, CM12, CM13, CM14, CM16, CM17, CM19, C212, C303, C304, (C309, C310 [K]), C506, C603-C607, C609, C611, C613-C616, C620, C626, C627, C630-C635, C638, C639, C643, C644, C646, C648-C651, C654	
RA11	U/K /02B/ 02G	4822 100 11352	P104-RESISTORS 10K Ω, Trimming 22K Ω, Trimming	RA01030780 RA02230780
RL14		4822 050 22209	22 Ω ±5% 1/4W	GG05220140
▲R207		4822 116 83929	220 Ω ±5% 1/4W	GG05221140
R211		4822 100 11373	4.7K Ω, Trimming	RA04720780
R212		4822 100 11352	22K Ω, Trimming	RA02230780
R217		4822 052 10221	220 Ω ±5% 1/6W	GG05221160
R512		4822 052 10221	220 Ω ±5% 1/6W	GG05221160
R610		4822 111 30999	10M Ω ±5% 1/4W	GD05106140
▲R613		4822 115 90167	100 Ω ±2% 1/4W, Fusible	NF02101140
R631		4822 111 31001	330 Ω ±5% 1/6W	GG05331160
R632		4822 111 31001	330 Ω ±5% 1/6W	GG05331160
R634		4822 052 10101	100 Ω ±5% 1/6W	GG05101160
R639		4822 052 10479	47 Ω ±5% 1/4W	GG05470140
R***			P104-RESISTORS (COMMON) Carbon film fixed resistor, ±5% 1/4W : R610	
R***			Carbon film fixed resistor, ±5% 1/6W : RA01, RA02, (RA03, RA04, RA06-RA09 [/ 02B/ 02G] , RA10, RF03-RF06, RL01-RL13, RM01-RM34, RM36, RM37, R201-R206, R208, R209, R210, R215-R216, R297, R301, R302, R501-R504, R506, R507, (R508 [U, K]), R509, R510, R511, R513, R514, R601-R609, R611, R612, R614-R630, R633, R635, R636, R637, R643-R647, R649, R650	
			P104-SEMICONDUCTORS	
DA01		4822 125 50416	Varicap SVC342-K	HD40009030
DA02	/02B/ 02G	4822 130 33697	Diode 1SS135	HD20017210
DA03	/02B/ 02G	4822 125 50416	Varicap SVC342-K	HD40009030
DA04	/02B/ 02G	4822 130 33697	Diode 1SS135	HD20017210
DA05		4822 130 33305	Diode 1SS176, etc.	HD20002000
DA06		4822 130 33305	Diode 1SS176, etc.	HD20002000
D501		4822 130 80317	Zener RD5.1JB2 / MTZJ5.1B	HD30511000
QA01	/02B/ 02G	4822 130 42298	Transistor 2SC536SP, etc.	HT30001000
QA02	/02B/ 02G	4822 130 42298	Transistor 2SC536SP, etc.	HT30001000
QA03	/02B/ 02G	4822 130 61892	Transistor 2SD2144S (U, V)	HT421442A0
QF01		4822 209 83631	IC NJM4558DD	HC10008090
QL01		4822 130 42298	Transistor 2SC536SP, etc.	HT30001000
QL02		4822 130 42298	Transistor 2SC536SP, etc.	HT30001000
QM01		4822 209 83631	IC NJM4558DD	HC10008090
QM04		4822 209 72748	IC LC7821	HC10228030
QM05		4822 209 72748	IC LC7821	HC10228030
Q201		4822 209 31001	IC LA1851N	HC10288030
Q202		4822 130 62294	Transistor 2SC1809S (P)	HT318091P0
Q203		4822 130 42682	Transistor, Digital DTA144ES/UN4113	BA10002000
Q204		4822 130 42682	Transistor, Digital DTA144ES/UN4113	BA10002000
Q205		4822 126 90006	Varistor PTH59F04BH222TS	HP00016230
Q501		4822 209 30178	IC LC7218	HC10221030
Q502		4822 130 42121	F.E.T. 2SK30A (Y)	HF200300B0
Q503		4822 130 42298	Transistor 2SC536SP, etc.	HT30001000
Q601		4822 209 32693	IC NJM2177L	HC10126090
Q602		4822 209 32694	IC MJU7901D	HC10127090
Q603		4822 209 32695	IC NJU3711D	HC10128090
Q604		4822 209 73275	IC TC9214P	HC10209050

POS.NO	VERSION	PART NO. (FOR EUROPE)	DESCRIPTION	PART NO. (FOR U/K)
P104-MISCELLANEOUS				
A101	/02B/02G U/K	4822 210 10567	V.H.F. Tuner FE417-G02 V.H.F. Tuner FE340-A01	AV01202230 AV01202240
FA01		4822 242 81262	Ceramic Filter SFP450F	FF10045390
F201	U			FF11070610
F202	/02B/02G/K	4822 242 71135 4822 242 71135	Ceramic Filter SFF10.7MA8-A Ceramic Filter SFE10.7MS3-A Ceramic Filter SFE10.7MS3-A	FF11070620 FF11070620
JL01		4822 267 31208	Terminal, 2P RCA	YT02020880
JL02		4822 265 30627	Terminal, 3P RCA	YT02030060
JL03		4822 290 81631	Terminal, 1P RCA	YT02010380
JL04		4822 265 10063	Jack, 6P VIDEO IN / OUT	YJ06002450
JW51	/02B/02G U/K	4822 290 60752	Terminal, 4P SPK Surround	YT03040330
JW52		4822 290 81567	Terminal, 4P SPK Surround Terminal, 2P SPK Center	YT03040370 YT03020150
J101	/02B/02G/K U	4822 290 81632	Terminal, Antenna Terminal, Antenna	YT03030020 YT01030080
LA01		4822 157 63084	ANT Coil, MW	LA10295170
LA02		4822 157 70779	OSC Coil, MW	LO70013010
LA03	/02B/02G	4822 157 52714	ANT Coil, LW	LA10295160
LA04	/02B/02G	4822 157 70781	OSC Coil, LW	LO70013020
LA05		4822 157 53589	Choke Coil	LC23960710
LA06		4822 148 81095	I.F.T. Coil, AM	LI70033510
L201		4822 157 63904	I.F.T. Coil, FM DET	LI70376010
L202	/02B/02G/K	4822 156 10794	M.P.X. Coil, Antirbird Filter	LS10295030
L601 ? L604		4822 157 70813	Choke Coil 47µH	LC14733800
S301	K		Slide Switch, Scan Step	SS02021470
X201		4822 242 81248	Ceramic Resonator CSB456F15	FQ04563020
X501		4822 242 72333	Crystal 7.2MHz	JX07001260
X601		4822 242 81525	Ceramic Resonator CST2.00MG040	FQ02004030
P304-TU POST AMP / SURR. BUFF CIRCUIT BOARD				
P304			TU POST AMP / SURR. BUFF PCB	WA183J2020
P304-CAPACITORS				
CG01 ? CG04 CG05 ? CG10 CG11 CG12 CG15 CG16 CG17		4822 124 23053	Elect 1µF 50V	FQ04563020 JX07001260 FQ02004303
		4822 124 21899	Elect 4.7µF 25V	EJ47502510
		4822 122 30043	Ceramic 0.01µF +80% -20% 50V	DK18103310
		4822 122 30043	Ceramic 0.01µF +80% -20% 50V	DK18103310
		4822 124 21899	Elect 4.7µF 25V	EJ47502510
		4822 124 21899	Elect 4.7µF 25V	EJ47502510
		4822 124 21894	Elect 10µF 16V	EJ10601610
		4822 124 21894	Elect 10µF 16V	EJ10601610
		4822 122 30043	Ceramic 0.01µF +80% -20% 50V	DK18103310
		4822 122 30043	Ceramic 0.01µF +80% -20% 50V	DK18103310
		4822 124 21899	Elect 4.7µF 25V	EJ47502510
		4822 124 21899	Elect 4.7µF 25V	EJ47502510
		4822 124 21899	Elect 4.7µF 25V	EJ47502510
		4822 124 21899	Elect 4.7µF 25V	EJ47502510
		4822 122 30043	Ceramic 0.01µF +80% -20% 50V	DK18103310
		4822 122 30043	Ceramic 0.01µF +80% -20% 50V	DK18103310
P304-RESISTORS				
RG15		4822 052 10221	220 Ω ±5% 1/6W	GG05221160
RG16		4822 052 10221	220 Ω ±5% 1/6W	GG05221160
R313		4822 052 10221	220 Ω ±5% 1/6W	GG05221160
R314		4822 052 10221	220 Ω ±5% 1/6W	GG05221160

POS.NO	VERSION	PART NO. (FOR EUROPE)	DESCRIPTION	PART NO. (FOR U/K)
<u>R***</u>			P304-RESISTORS (COMMON) Carbon film fixed resistor, ±5% 1/6W : RF07, RF08, RG01~RG14, RG17~RG21, RG25, R303~R312	
			P304-SEMICONDUCTORS	
D201		4822 130 33305	Diode 1SS176, etc.	HD20002000
QA04	/02B/02G	4822 130 42682	Transistor, Digital DTA144ES	BA10002000
QA05	/02B/Q2G	4822 130 42682	Transistor, Digital DTA144ES	BA10002000
QG01		4822 209 83631	IC NJM4558DD	HC10008090
QG02		4822 209 31575	IC TC7213P	HC10304050
QG03		4822 209 83631	IC NJM4558DD	HC10008090
QG04		4822 209 83631	IC NJM4558DD	HC10008090
Q301		4822 209 83631	IC NJM4558DD	HC10008090
			P304-MISCELLANEOUS	
L301		4822 157 70021	M.P.X. Coil 19.38KHz	LC10293010
L302		4822 157 70021	M.P.X. Coil 19.38KHz	LC10293010

NOTE ON SAFETY:

Symbol ▲ Fire or electrical shock hazard. Only original parts should be used to replace any part marked with symbol ▲. Any other component substitution (other than original type), may increase risk of fire or electrical shock hazard.

SR-73 SCHEMATIC DIAGRAM

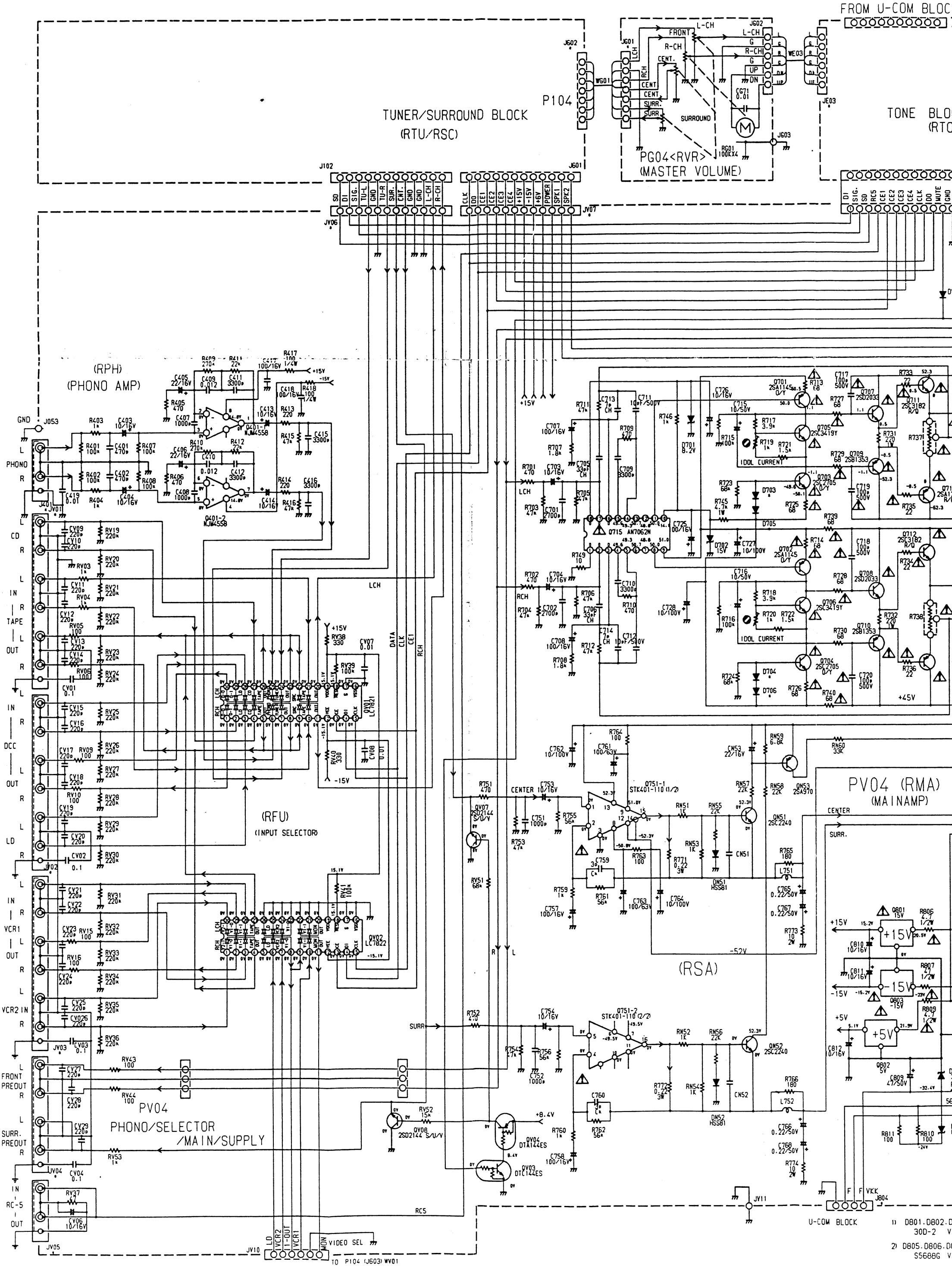

1) D801.0802.0
300-2 V
2) D805.0806.0
55686 V

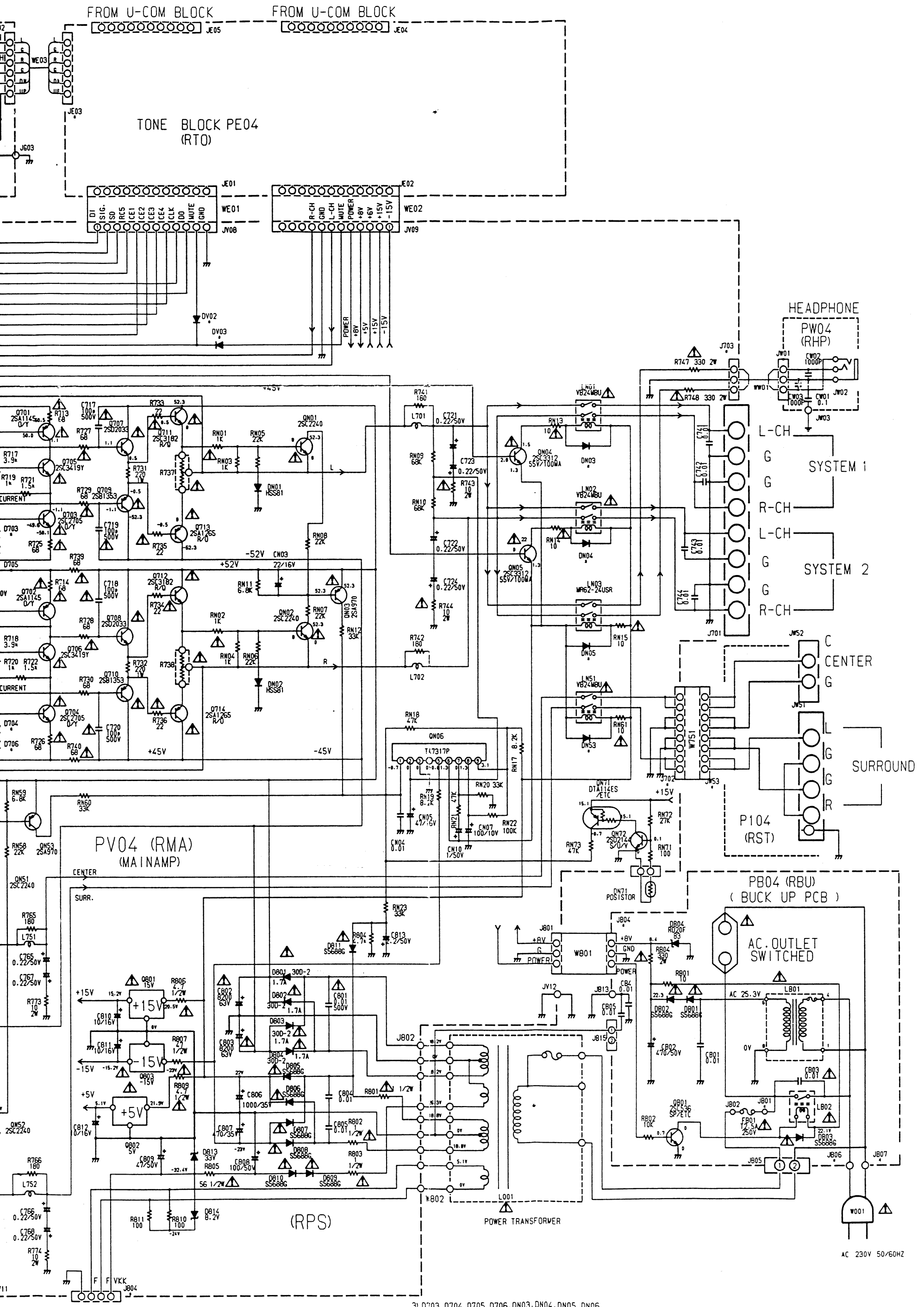

U-COM BLOCK

- 1) D801, D802, D803, D804
300-2 VR-200V 1.7A
- 2) D805, D806, D807, D808, D809, D810, D811, D801, D802, D803
S5686G VR-400V 1A

- 3) D703, D704, D705, D706, D803, D804, D805, D806
D851, D852, DV02, DV03
1SS176 OR MA165 OR 1SS254
- 4) D801 VR-30V 0.1A
2SC536SP OR 2SC2458 OR 2SC3311 OR 2SC1740S

SR-73 SCHEMATIC DIAGRAM

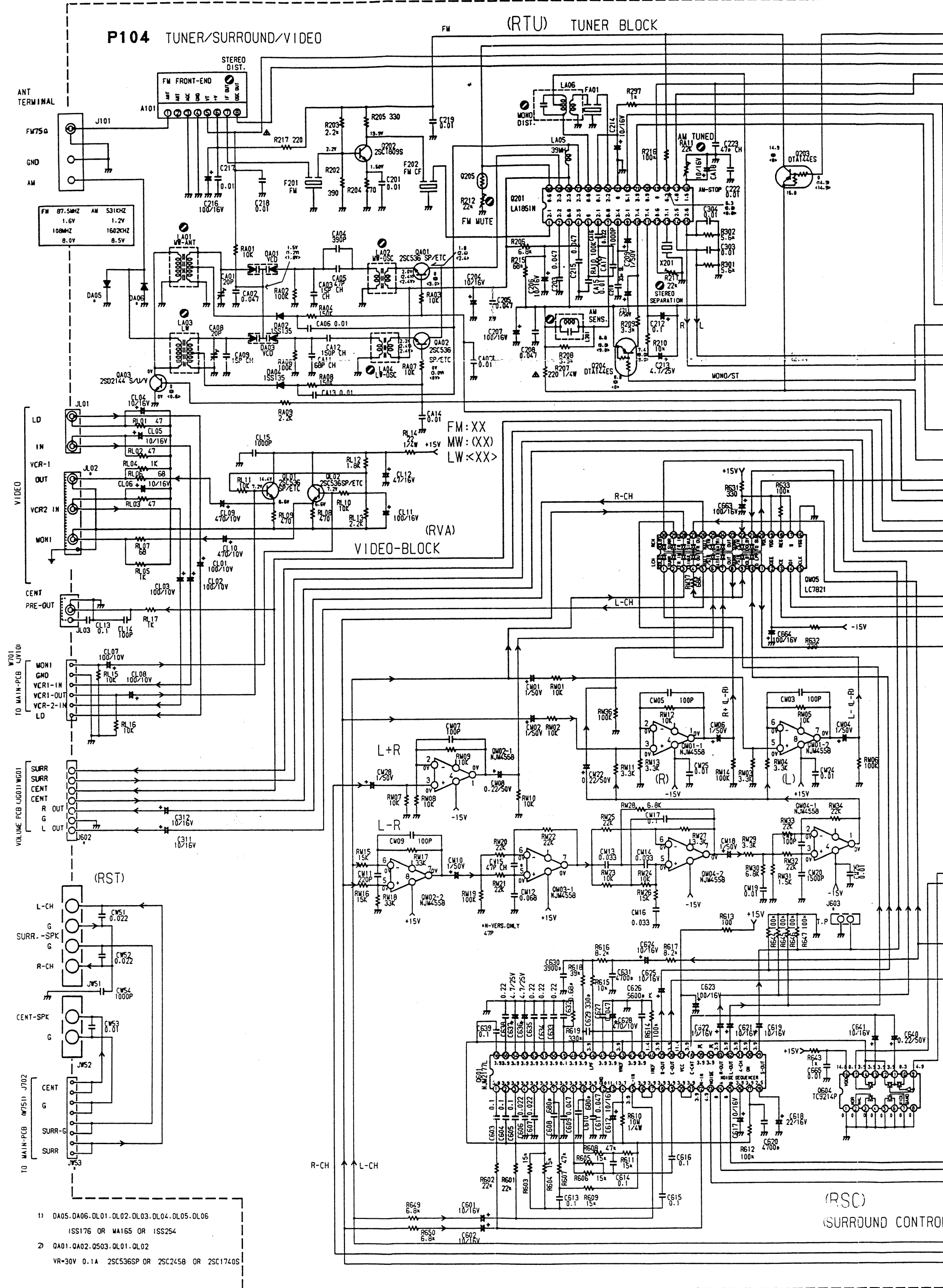

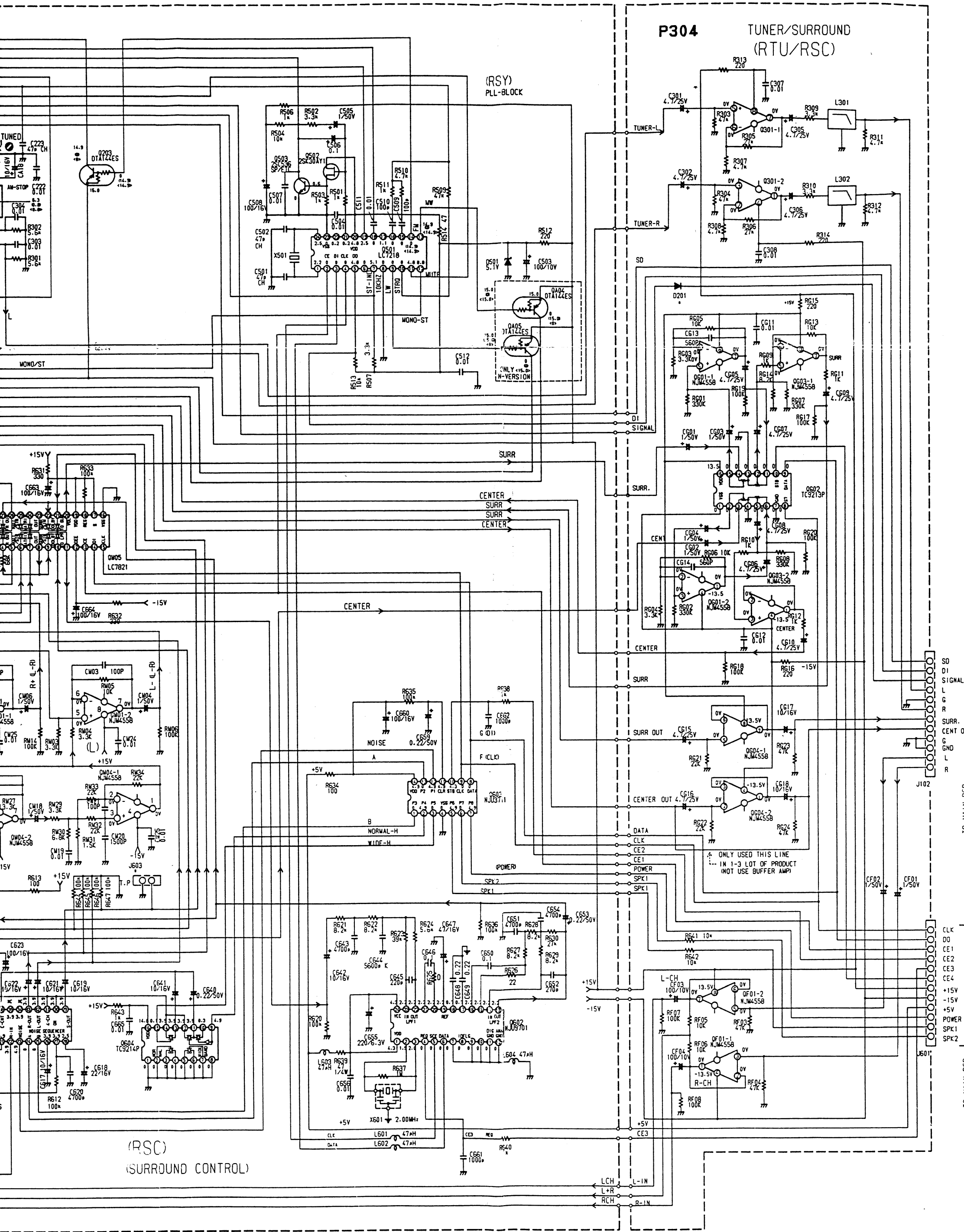

P304

TUNER/SURROUND (RTU/RSC)

(RSY) PLL-BLOCK

(RSC) SURROUND CONTROL

ONLY USED THIS LINE IN 1-3 LOT OF PRODUCT (NOT USE BUFFER AMP)

SD
D1
SIGNAL
L
G
R
SURR.
CENT
O
G
ND
L
R
TO MAIN-PCB
CLK
DO
CE1
CE2
CE3
CE4
+15V
-15V
POWER
SPK1
SPK2
TO MAIN-PCB