

Service Manual

SR7300 /N1B/U1B/K1G/N1G/U1G
 SR7300F /N1B/U1B/K1G/N1G/U1G
 AV Surround Receiver

PS7300 /F1B/F1N
 AV Surround Amplifier

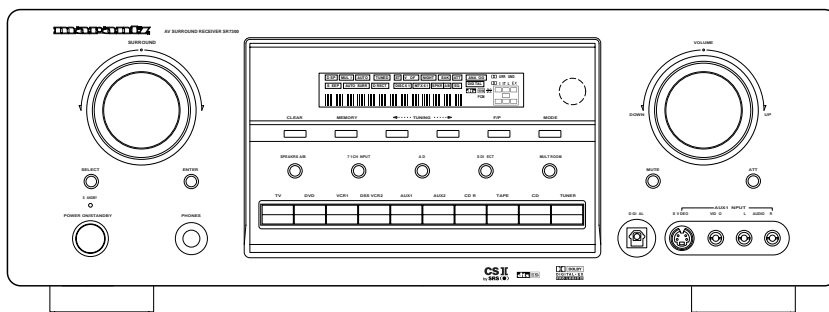

CS II
 by SRS

dts ES

DOLBY DIGITAL EX PRO LOGIC II

PS7300
 SR7300 / SR7300F

TABLE OF CONTENTS

SECTION	PAGE
1. TECHNICAL SPECIFICATIONS AND SERVICE TOOL	1
2. TECHNICAL DESCRIPTION	4
3. WIRING DIAGRAM	5
4. BLOCK DIAGRAM	7
5. SCHEMATIC DIAGRAM	9
6. PARTS LOCATION	25
7. IC DATA	36
8. EXPLODED VIEW AND PARTS LIST	47
9. SERVICE PROGRAM	51
10. UPDATE FIRMWARE	53
11. POWER AMPLIFIER ADJUSTMENT	55
12. SYSTEM ERROR	56
13. TROUBLE SHOOTING	57
14. ELECTRICAL PARTS LIST	61

Please use this service manual with referring to the user guide (D.F.U.) without fail.
 修理の際は、必ず取扱説明書を準備し操作方法を確認の上作業を行ってください。

marantz®

SR7300 / SR7300SE / PS7300

MARANTZ DESIGN AND SERVICE

Using superior design and selected high grade components, **MARANTZ** company has created the ultimate in stereo sound. Only original **MARANTZ** parts can insure that your **MARANTZ** product will continue to perform to the specifications for which it is famous.

Parts for your **MARANTZ** equipment are generally available to our National Marantz Subsidiary or Agent.

ORDERING PARTS :

Parts can be ordered either by mail or by Fax.. In both cases, the correct part number has to be specified.

The following information must be supplied to eliminate delays in processing your order :

1. Complete address
2. Complete part numbers and quantities required
3. Description of parts
4. Model number for which part is required
5. Way of shipment
6. Signature : any order form or Fax. must be signed, otherwise such part order will be considered as null and void.

USA

MARANTZ AMERICA, INC
1100 MAPLEWOOD DRIVE
ITASCA, IL. 60143
USA
PHONE : 630 - 741 - 0300
FAX : 630 - 741 - 0301

EUROPE / TRADING

MARANTZ EUROPE B.V.
P. O. BOX 8744, BUILDING SILVERPOINT
BEEMDSTRAAT 11, 5653 MA EINDHOVEN
THE NETHERLANDS
PHONE : +31 - 40 - 2507844
FAX : +31 - 40 - 2507860

CANADA

LENBROOK INDUSTRIES LIMITED
633 GRANITE COURT,
PICKERING, ONTARIO L1W 3K1
CANADA
PHONE : 905 - 831 - 6333
FAX : 905 - 831 - 6936

PROFESSIONAL AMERICAS

SUPERSCOPE TECHNOLOGIES, INC.
MARANTZ PROFESSIONAL PRODUCTS
2640 WHITE OAK CIRCLE, SUITE A
AURORA, ILLINOIS 60504 USA
PHONE : 630 - 820 - 4800
FAX : 630 - 820 - 8103

PROFESSIONAL AUSTRALIA

TECHNICAL AUDIO GROUP PTY, LTD
558 DARLING STREET,
BALMAIN, NSW 2041,
AUSTRALIA
PHONE : 61 - 2 - 9810 - 5300
FAX : 61 - 2 - 9810 - 5355

PROFESSIONAL HONG KONG

Jolly ProAudio Broadcast Engineering Ltd.
UNIT 2, 10F, WAH HUNG CENTRE,
41 HUNG TO ROAD, KWUN TONG, KLN.,
HONG KONG
PHONE : 852 - 21913660
FAX : 852 - 21913990

AUSTRALIA

QualiFi Pty Ltd,
24 LIONEL ROAD,
MT. WAVERLEY VIC 3149
AUSTRALIA
PHONE : +61 - (0)3 - 9543 - 1522
FAX : +61 - (0)3 - 9543 - 3677

THAILAND

MRZ STANDARD CO., LTD
746 - 754 MAHACHAI ROAD.,
WANGBURAPAPIROM, PHRANAKORN,
BANGKOK, 10200 THAILAND
PHONE : +66 - 2 - 222 9181
FAX : +66 - 2 - 224 6795

SINGAPORE

WO KEE HONG DISTRIBUTION PTE LTD
130 JOO SENG ROAD
#03-02 OLIVINE BUILDING
SINGAPORE 368357
PHONE : +65 6858 5535 / +65 6381 8621
FAX : +65 6858 6078

NEW ZEALAND

WILDASH AUDIO SYSTEMS NZ
14 MALVERN ROAD MT ALBERT
AUCKLAND NEW ZEALAND
PHONE : +64 - 9 - 8451958
FAX : +64 - 9 - 8463554

TAIWAN

PAI- YUING CO., LTD.
6 TH FL NO, 148 SUNG KIANG ROAD,
TAIPEI, 10429, TAIWAN R.O.C.
PHONE : +886 - 2 - 25221304
FAX : +886 - 2 - 25630415

MALAYSIA

WO KEE HONG ELECTRONICS SDN. BHD.
2ND FLOOR BANGUNAN INFINITE CENTRE
LOT 1, JALAN 13/6, 46200 PETALING JAYA
SELANGOR DARUL EHSAN, MALAYSIA
PHONE : +60 - 3 - 7954 8088
FAX : +60 - 3 - 7954 7088

JAPAN Technical

MARANTZ JAPAN, INC.
35- 1, 7- CHOME, SAGAMIONO
SAGAMIHARA - SHI, KANAGAWA
JAPAN 228-8505
PHONE : +81 42 748 1013
FAX : +81 42 741 9190

日本マランツ株式会社

本社 〒228-8505
神奈川県相模原市相模大野7-35-1
営業本部 〒150-0022
東京都渋谷区恵比寿南1-11-9

KOREA

MK ENTERPRISES LTD.
ROOM 604/605, ELECTRO-OFFICETEL, 16-58,
3GA, HANGANG-RO, YONGSAN-KU, SEOUL
KOREA
PHONE : +822 - 3232 - 155
FAX : +822 - 3232 - 154

SHOCK, FIRE HAZARD SERVICE TEST :

CAUTION : After servicing this appliance and prior to returning to customer, measure the resistance between either primary AC cord connector pins (with unit NOT connected to AC mains and its Power switch ON), and the face or Front Panel of product and controls and chassis bottom.

Any resistance measurement less than 1 Megohms should cause unit to be repaired or corrected before AC power is applied, and verified before it is return to the user/customer.

Ref. UL Standard No. 1492.

In case of difficulties, do not hesitate to contact the Technical Department at above mentioned address.

1. TECHNICAL SPECIFICATIONS AND SERVICE TOOL

TECHNICAL SPECIFICATIONS

FM TUNER SECTION (SR ONLY)

Frequency Range87.5 - 108.0 MHz
Usable SensitivityIHF 1.8 μ V/16.4 dB
Signal to Noise Ratio Mono/Stereo 76/72 dB
Distortion..... Mono/Stereo 0.2/0.3 %
Stereo Separation..... 1 kHz 45 dB
Alternate Channel Selectivity \pm 300 kHz 60 dB
Image Rejection..... 98 MHz 70 dB
Tuner Output Level..... 1 kHz, \pm 40 kHz Dev 800 mV(/K/N)
..... 1 kHz, \pm 75 kHz Dev 800 mV(/U)

AM TUNER SECTION (SR ONLY)

Frequency Range 531 - 1602 kHz (/K/N)
Frequency Range520 - 1710 kHz (/U)
Signal to Noise Ratio50 dB
Usable Sensitivity..... Loop 400 μ V
Distortion..... 400 Hz, 30 % Mod. 0.5 % (/K/N)
..... 1 kHz, 30 % Mod. 0.5 % (/U)
Selectivity..... \pm 18 kHz 70 dB (/K/N)
..... \pm 20 kHz 70 dB (/U)

AUDIO SECTION

Power Output (20 Hz - 20 kHz/THD=0.08%)
Front L&R.....8 ohms 105 W / Ch
Center8 ohms 105 W / Ch
Surround L&R8 ohms 105 W / Ch
Surround Back8 ohms 105 W / Ch
Front L&R.....6 ohms 130 W / Ch
Center6 ohms 130 W / Ch
Surround L&R6 ohms 130 W / Ch
Surround Back6 ohms 130 W / Ch
Input Sensitivity/Impedance..... 168 mV/ 47 kohms
Signal to Noise Ratio(Analog Input / Source Direct) 105 dB
Frequency Response
Analog Input / Source Direct8 Hz - 100 kHz (\pm 3 dB)
Digital Input / 96 kHz PCM..... 8 Hz - 45 kHz (\pm 3 dB)

VIDEO

Television Format NTSC (/F/U)
.....NTSC/PAL (/K/N)
Input Level/Impedance..... 1 Vp-p/75 ohms
Output Level/Impedance..... 1 Vp-p/75 ohms
Video Frequency Response..... 5 Hz to 10 MHz ($-$ 3 dB) (/K/N)
.....5 Hz to 8 MHz ($-$ 1 dB) (/U)
Component Video Frequency Response . 5 Hz to 40 MHz ($-$ 3 dB) (/K/N)
S/N.....60 dB

GENERAL

Power Requirement AC 100 V 50/60 Hz (/F)
..... AC 230 V 50 Hz (/K/N)
.....AC 120 V 60 Hz (/U)
Power Consumption..... 480 W
Weight28.9 lbs (13.1 Kg) (/K/N/U)
..... 14.7 Kg (/F)

ACCESSORIES

Remote Control Unit
RC7300SR 1
AA-size batteries..... 2
FM Antenna (SR ONLY)..... 1
AM Loop Antenna (SR ONLY) 1
AC Cable.....1 (/F/K/N)

Specifications subject to change without prior notice.

SERVICE TOOL

Updated of the CPU and DSP DISC *SR7300CDR
(The disc is regarding when exchanged in QU01.)

The relation between the selected surround mode and the input signal

The surround mode is selected with the surround mode buttons on SR7300/SR7300F/PS7300 or the remote control unit. However, the sound you hear is subject to the relationship between the selected surround mode and input signal. That relationship is as follows;

Surround Mode	Input Signal	Decoding	Output Channel					Front information display	
			L/R	C	SL SR	SB	SubW	Signal format indicators	Channel status
AUTO	Dolby Surr. EX	Dolby Digital EX	○	○	○	○	○	□□ DIGITAL	L, C, R, SL, SR, S, LFE
	Dolby D (5.1ch)	Dolby Digital 5.1	○	○	○	-	-	□□ DIGITAL	L, C, R, SL, SR, LFE
	Dolby D(2ch)	Dolby Digital 2.0	○	-	-	-	-	□□ DIGITAL	L, R
	Dolby D (2ch Surr)	Pro Logic II movie	○	○	○	-	-	□□ DIGITAL , □□ SURROUND	L, R, S
	DTS-ES	DTS-ES	○	○	○	○	○	dts , ES	L, C, R, SL, SR, S, LFE
	DTS 96/24	DTS 96/24	○	○	○	-	-	dts 96/24	L, C, R, SL, SR, LFE
	DTS (5.1ch)	DTS 5.1	○	○	○	-	○	dts	L, C, R, SL, SR, LFE
	PCM(Audio)	PCM (Stereo)	○	-	-	-	-	PCM	L, R
	PCM 96kHz	PCM (96kHz Stereo)	○	-	-	-	-	PCM	L, R
	Analog	Stereo	○	-	-	-	-	ANALOG	-
S-DIRECT	Dolby D Surr. EX	Dolby Digital EX	○	○	○	○	○	□□ DIGITAL	L, C, R, SL, SR, S, LFE
	Dolby D (5.1ch)	Dolby Digital 5.1	○	○	○	-	○	□□ DIGITAL	L, C, R, SL, SR, LFE
	Dolby D (2ch)	Dolby Digital 2.0	○	-	-	-	-	□□ DIGITAL	L, R
	Dolby D (2ch Surr)	Pro Logic II movie	○	○	○	-	-	□□ DIGITAL , □□ SURROUND	L, R, S
	DTS-ES	DTS-ES	○	○	○	○	○	dts , ES	L, C, R, SL, SR, S, LFE
	DTS 96/24	DTS 96/24	○	○	○	-	-	dts 96/24	L, C, R, SL, SR, LFE
	DTS (5.1ch)	DTS 5.1	○	○	○	-	○	dts	L, C, R, SL, SR, LFE
	PCM (Audio)	PCM (Stereo)	○	-	-	-	-	PCM	L, R
	PCM 96kHz	PCM (96kHz Stereo)	○	-	-	-	-	PCM	L, R
	Analog	Stereo	○	-	-	-	-	ANALOG	-
EX/ES	Dolby D Surr. EX	Dolby Digital EX	○	○	○	○	○	□□ DIGITAL	L, C, R, SL, SR, S, LFE
	Dolby D (5.1ch)	Dolby Digital EX	○	○	○	○	○	□□ DIGITAL	L, C, R, SL, SR, LFE
	DTS-ES	DTS-ES	○	○	○	○	○	dts , ES	L, C, R, SL, SR, S, LFE
	DTS(5.1ch)	DTS-ES	○	○	○	○	○	dts	L, C, R, SL, SR, LFE
DOLBY (PL II movie) (PL II music) (Pro Logic)	Dolby D Surr. EX	Dolby Digital 5.1	○	○	○	-	○	□□ DIGITAL	L, C, R, SL, SR, S, LFE
	Dolby D (5.1ch)	Dolby Digital 5.1	○	○	○	-	○	□□ DIGITAL	L, C, R, SL, SR, LFE
	Dolby D (2ch)	Pro Logic II	○	○	○	-	-	□□ DIGITAL	L, R
	Dolby D (2ch Surr)	Pro Logic II	○	○	○	-	-	□□ DIGITAL , □□ SURROUND	L, R, S
	PCM (Audio)	Pro Logic II	○	○	○	-	-	PCM	L, R
	Analog	Pro Logic II	○	○	○	-	-	ANALOG	-
DTS (Neo:6 Cinema) (Neo:6 Music)	DTS-ES	DTS 5.1	○	○	○	-	○	dts , ES	L, C, R, SL, SR, S, LFE
	DTS 96/24	DTS 96/24	○	○	○	-	○	dts 96/24	L, C, R, SL, SR, LFE
	DTS (5.1ch)	DTS 5.1	○	○	○	-	○	dts	L, C, R, SL, SR, LFE
	PCM (Audio)	Neo:6	○	○	○	○	-	PCM	L, R
	Analog	Neo:6	○	○	○	○	-	ANALOG	-
	Dolby D (2ch)	Neo:6	○	○	○	○	-	□□ DIGITAL	L, R
	Dolby D (2ch Surr)	Neo:6	○	○	○	○	-	□□ DIGITAL , □□ SURROUND	L, R, S
CS II Cinema CS II Music CS II Mono	PCM (Audio)	CS II	○	○	○	○	○	PCM	L, R
	Analog	CS II	○	○	○	○	○	ANALOG	-
	Dolby D (2ch)	CS II	○	○	○	○	○	□□ DIGITAL	L, R
	Dolby D (2ch Surr)	CS II	○	○	○	○	○	□□ DIGITAL , □□ SURROUND	L, R, S
STEREO	Dolby Surr. EX	Stereo	○	-	-	-	○	□□ DIGITAL	L, C, R, SL, SR, S, LFE
	Dolby D (5.1ch)	Stereo	○	-	-	-	○	□□ DIGITAL	L, C, R, SL, SR, LFE
	Dolby D (2ch)	Stereo	○	-	-	-	-	□□ DIGITAL	L, R
	Dolby D (2ch Surr)	Stereo	○	-	-	-	-	□□DIGITAL , □□ SURROUND	L, R, S
	DTS-ES	Stereo	○	-	-	-	○	dts , ES	L, C, R, SL, SR, S, LFE
	DTS 96/24	Stereo	○	-	-	-	○	dts 96/24	L, C, R, SL, SR, LFE
	DTS (5.1ch)	Stereo	○	-	-	-	○	dts	L, C, R, SL, SR, LFE
	PCM (Audio)	Stereo	○	-	-	-	-	PCM	L, R
	PCM 96kHz	Stereo	○	-	-	-	-	PCM	L, R
	Analog	Stereo	○	-	-	-	-	ANALOG	-
Virtual	Dolby Surr. EX	Virtual	○	-	-	-	-	□□ DIGITAL	L, C, R, SL, SR, S, LFE
	Dolby D (5.1ch)	Virtual	○	-	-	-	-	□□ DIGITAL	L, C, R, SL, SR, LFE
	Dolby D (2ch)	Virtual	○	-	-	-	-	□□ DIGITAL	L, R
	Dolby D (2ch Surr)	Virtual	○	-	-	-	-	□□ DIGITAL , □□ SURROUND	L, R, S
	DTS-ES	Virtual	○	-	-	-	-	dts , ES	L, C, R, SL, SR, S, LFE
	DTS (5.1ch)	Virtual	○	-	-	-	-	dts	L, C, R, SL, SR, LFE
	PCM (Audio)	Virtual	○	-	-	-	-	PCM	L, R
	Analog	Virtual	○	-	-	-	-	ANALOG	-
Multi Ch. Stereo	Dolby Surr. EX	Dolby Digital EX	○	○	○	○	○	□□ DIGITAL	L, C, R, SL, SR, S, LFE
	Dolby D (5.1ch)	Dolby Digital 5.1	○	○	○	-	○	□□ DIGITAL	L, C, R, SL, SR, LFE
	Dolby D (2ch)	Multi Channel Stereo	○	○	○	○	-	□□ DIGITAL	L, R
	Dolby D (2ch Surr)	Multi Channel Stereo	○	○	○	○	-	□□ DIGITAL , □□ SURROUND	L, R, S
	DTS-ES	DTS-ES	○	○	○	○	○	dts , ES	L, C, R, SL, SR, S, LFE
	DTS (5.1ch)	DTS 5.1	○	○	○	-	○	dts	L, C, R, SL, SR, LFE
	PCM (Audio)	Multi Channel Stereo	○	○	○	○	-	PCM	L, R
	Analog	Multi Channel Stereo	○	○	○	○	-	ANALOG	-

Note:

- Dolby Digital (2 ch: Lt/Rt): signal with Dolby Surround flag Speakers are full set.
- No sound outputs from the surround speaker, center speaker and subwoofer if the DVD disc has no surround data.

- L/R : Front speakers
- C : Center speaker
- SL/SR : Surround speakers
- S : Surround Back speaker
- LFE : Sub woofer speaker

Remark : Bass signal output from Sub Woofer terminal for SR7300 / SR7300F / PS7300

*Stereo decode : SPK SETUP - BASS MIX : BOTH set

SPK setup					SubWoofer Output by Decoded mode					
Sub Woofer	Front	Center	Surr.	Surr.B	DD EX	Dolby(AC-3≠2ch)	PL II,Neo6	CS II	Stereo	Virtual
			L/R	(L/R)	DTS mES,dES	DTS, DTS96/24			(PCM:Auto)	(Main spk L fix)
Yes	Large	Large	Large	Large	LFE	LFE	none	L+R	L+R	no output
				Small	LFE+Sb	↓	↓	↓	↓	↓
				None	no suuround mode	↓	↓	↓	↓	↓
			Small	Large	LFE+SL+SR	LFE+SL+SR	↓	↓	↓	↓
				Small	LFE+SL+SR+Sb	↓	↓	↓	↓	↓
				None	no suuround mode	↓	↓	↓	↓	↓
			None	(prohibit)	no suuround mode	LFE	↓	↓	↓	↓
		Small	Large	Large	LFE+C	LFE+C	C	L+R	L+R	no output
				Small	LFE+C+Sb	↓	↓	↓	↓	↓
				None	no suuround mode	↓	↓	↓	↓	↓
			Small	Large	LFE+C+SL+SR	LFE+C+SL+SR	↓	↓	↓	↓
				Small	LFE+C+SL+SR+Sb	↓	↓	↓	↓	↓
				None	no suuround mode	↓	↓	↓	↓	↓
			None	(prohibit)	no suuround mode	LFE+C	↓	↓	↓	↓
		None	Large	Large	LFE	LFE	none	L+R	L+R	no output
				Small	LFE+Sb	↓	↓	↓	↓	↓
				None	no suuround mode	↓	↓	↓	↓	↓
			Small	Large	LFE+SL+SR	LFE+SL+SR	↓	↓	↓	↓
				Small	LFE+SL+SR+Sb	↓	↓	↓	↓	↓
				None	no suuround mode	↓	↓	↓	↓	↓
			None	(prohibit)	no suuround mode	LFE	↓	↓	↓	↓
	Small	Large	Large	Large	LFE+L+R	LFE+L+R	L+R	L+R	L+R	no output
				Small	LFE+L+R+Sb	↓	↓	↓	↓	↓
				None	no suuround mode	↓	↓	↓	↓	↓
			Small	Large	LFE+L+R+SL+SR	LFE+L+R+SL+SR	↓	↓	↓	↓
				Small	LFE+L+R+SL+SR+Sb	↓	↓	↓	↓	↓
				None	no suuround mode	↓	↓	↓	↓	↓
			None	(prohibit)	no suuround mode	LFE+L+R	↓	↓	↓	↓
		Small	Large	Large	LFE+L+R+C	LFE+L+R+C	L+R+C	L+R	L+R	no output
				Small	LFE+L+R+C+Sb	↓	↓	↓	↓	↓
				None	no suuround mode	↓	↓	↓	↓	↓
			Small	Large	LFE+L+R+C+SL+SR	LFE+L+R+C+SL+SR	↓	↓	↓	↓
				Small	LFE+L+R+C+SL+SR+Sb	↓	↓	↓	↓	↓
				None	no suuround mode	↓	↓	↓	↓	↓
			None	(prohibit)	no suuround mode	LFE+L+R+C	↓	↓	↓	↓
		None	Large	Large	LFE+L+R	LFE+L+R	L+R	L+R	L+R	no output
				Small	LFE+L+R+Sb	↓	↓	↓	↓	↓
				None	no suuround mode	↓	↓	↓	↓	↓
			Small	Large	LFE+L+R+SL+SR	LFE+L+R+SL+SR	↓	↓	↓	↓
				Small	LFE+L+R+SL+SR+Sb	↓	↓	↓	↓	↓
				None	no suuround mode	↓	↓	↓	↓	↓
			None	(prohibit)	no suuround mode	LFE+L+R	↓	↓	↓	↓
None					No output					

2. TECHNICAL DESCRIPTION



DTS was introduced in 1994 to provide 5.1 channels of discrete digital audio into home theater systems. DTS brings you premium quality discrete multi-channel digital sound to both movies and music. DTS is a multi-channel sound system designed to create full range digital sound reproduction. The no compromise DTS digital process sets the standard of quality for cinema sound by delivering an exact copy of the studio master recordings to neighborhood and home theaters. Now, every moviegoer can hear the sound exactly as the movie-maker intended. DTS can be enjoyed in the home for either movies or music on DVD's, LD's, and CD's. "DTS" and "DTS Digital Surround" are registered trademarks of Digital Theater Systems, Inc.



The advantages of discrete multichannel systems over matrix are well known. But even in homes equipped for discrete multichannel, there remains a need for high-quality matrix decoding. This is because of the large library of matrix surround motion pictures available on disc and on VHS tape; and analog television broadcasts. The typical matrix decoder of today derives a center channel and a mono surround channel from two-channel matrix stereo material. It is better than a simple matrix in that it includes steering logic to improve separation, but because of its mono, band-limited surround it can be disappointing to users accustomed to discrete multichannel. Neo 6 offers several important improvements as follow, . Neo 6 provides up to six full-band channels of matrix decoding from stereo matrix material. Users with 6.1 and 5.1 systems will derive six and five separate channels, respectively, corresponding to the standard home-theater speaker layouts. . Neo 6 technology allows various sound elements within a channel or channels to be steered separately, and in a way which follows naturally from the original presentation. . Neo 6 offers a music mode to expand stereo nonmatrix recordings into the five- or six-channel layout, in a way which does not diminish the subtlety and integrity of the original stereo recording.



DTS-ES Extended Surround is a new multi-channel digital signal format developed by Digital Theater Systems Inc. While offering high compatibility with the conventional DTS Digital Surround format, DTS-ES Extended Surround greatly improves the 360-degree surround impression and space expression thanks to further expanded surround signals. This format has been used professionally in movie theaters since 1999. In addition to the 5.1 surround channels (FL, FR, C, SL, SR and LFE), DTS-ES Extended Surround also offers the SB (Surround Back) channel for surround playback with a total of 6.1 channels. DTS-ES Extended Surround includes two signal formats with different surround signal recording methods, as DTS-ES Discrete 6.1 and DTS-ES Matrix 6.1. "DTS", "DTS-ES Extended Surround" and "Neo:6" are trademarks of Digital Theater Systems, Inc.



The stereo CD is a 16-bit medium with sampling at 44.1 kHz. Professional audio has been 20- or 24-bit for some time, and there is increasing interest in higher sampling rates both for recording and for delivery into the home. Greater bit depths provide extended dynamic range. Higher sampling rates allow wider frequency response and the use of anti-alias and reconstruction filters with

more favorable aural characteristics. DTS 96/24 allows for 5.1 channel sound tracks to be encoded at a rate of 96kHz/24bits on DVD-Video titles. When DVD-video appeared, it became possible to deliver 24-bit, 96 kHz audio into the home, but only in two channels, and with serious limitations on picture. This capability has had little use. DVD-audio allows 96/24 in six channels, but a new player is needed, and only analog outputs are provided, necessitating the use of the D/A converters and analog electronics provided in the player. DTS 96/24 offers the following:

1. Sound quality transparent to the original 96/24 master.
2. Full backward compatibility with all existing decoders. (Existing decoders will output a 48 kHz signal)
3. No new player required: DTS 96/24 can be carried on DVD-video, or in the video zone of DVD-audio, accessible to all DVD players.
4. 96/24 5.1-channel sound with full-quality full-motion video, for music programs and motion picture soundtracks on DVD-video.



Dolby Digital identifies the use of Dolby Digital (AC-3) audio coding for such consumer formats as DVD and DTV. As with film sound, Dolby Digital can provide up to five full-range channels for left, center, and right screen channels, independent left and right surround channels, and a sixth (".1") channel for low-frequency effects. Dolby Surround Pro Logic II is an improved matrix decoding technology that provides better spatiality and directionality on Dolby Surround program material; provides a convincing three-dimensional soundfield on conventional stereo music recordings; and is ideally suited to bring the surround experience to automotive sound. While conventional surround programming is fully compatible with Dolby Surround Pro Logic II decoders, soundtracks will be able to be encoded specifically to take full advantage of Pro Logic II playback, including separate left and right surround channels. (Such material is also compatible with conventional Pro Logic decoders.) Dolby Digital EX creates six full-bandwidth output channels from 5.1- channel sources. This is done using a matrix decoder that derives three surround channels from the two in the original recording. For best results, Dolby Digital EX should be used with movies soundtracks recorded with Dolby Digital Surround EX. Manufactured under license from Dolby Laboratories. "Dolby", "Pro Logic", and the double-D symbol are trademarks of Dolby Laboratories.



Circle Surround II (CS-II) is a powerful and versatile multi-channel surround sound playback from mono, stereo, CS encoded sources and other matrix encoded sources. In all cases the decoder extends it into 6 channels of surround audio and a LFE/subwoofer signal. The CS-II decoder creates a listening environment that places the listener "inside" music performances and dramatically improves both hi-fi audio conventional surround-encoded video material. CS-II provides composite stereo rear channels to greatly improve separation and image positioning adding a heightened sense of realism to both audio and A/V productions. CS-II is packed with other useful feature like dialog clarity (SRS Dialog) for movies and cinema-like bass enrichment (TruBass). CS-II can enable the dialog to become clearer and more discernable in movies and it enables the bass frequencies contained in the original programming to more closely achieve low frequencies overcoming the low frequency limitations of the speakers by full octave. SRS Circle Surround II, SRS Dialog, SRS TruBass, SRS and symbol  are trademarks of SRS Labs, Inc. SRS Circle Surround II, SRS Dialog and SRS TruBass technology are incorporated under license from SRS Labs, Inc.

3. WIRING DIAGRAM

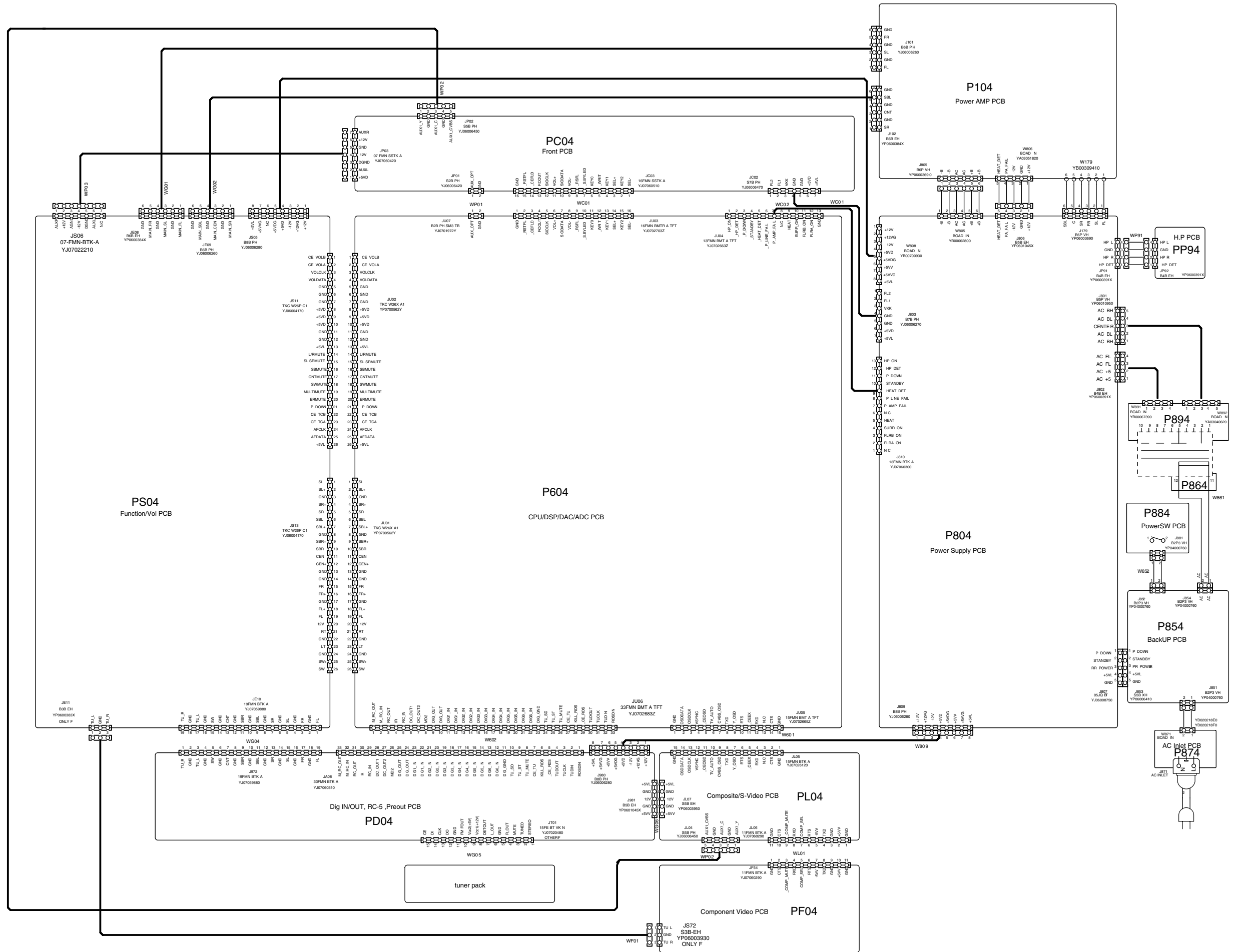

4. BLOCK DIAGRAM

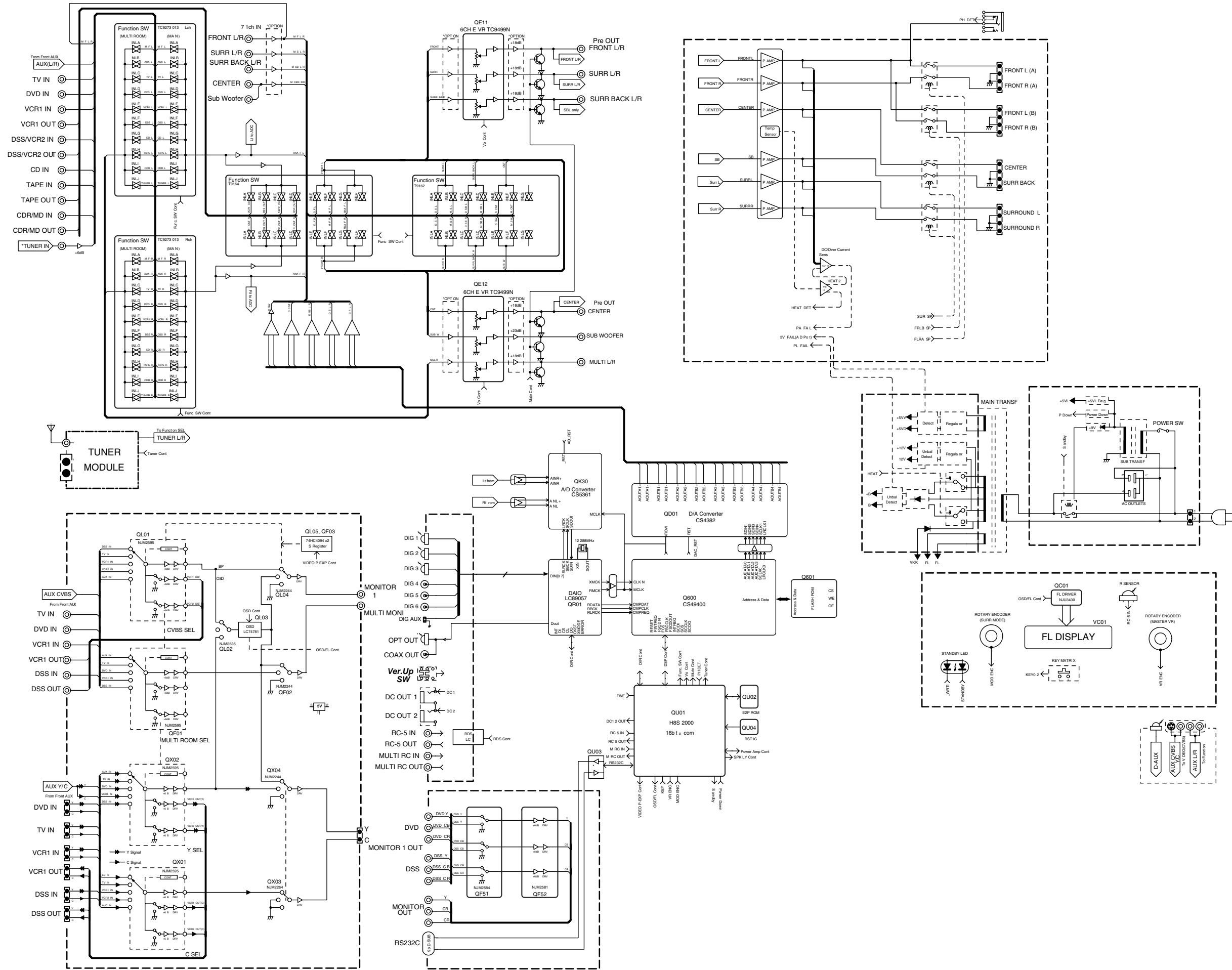

5. SCHEMATIC DIAGRAM

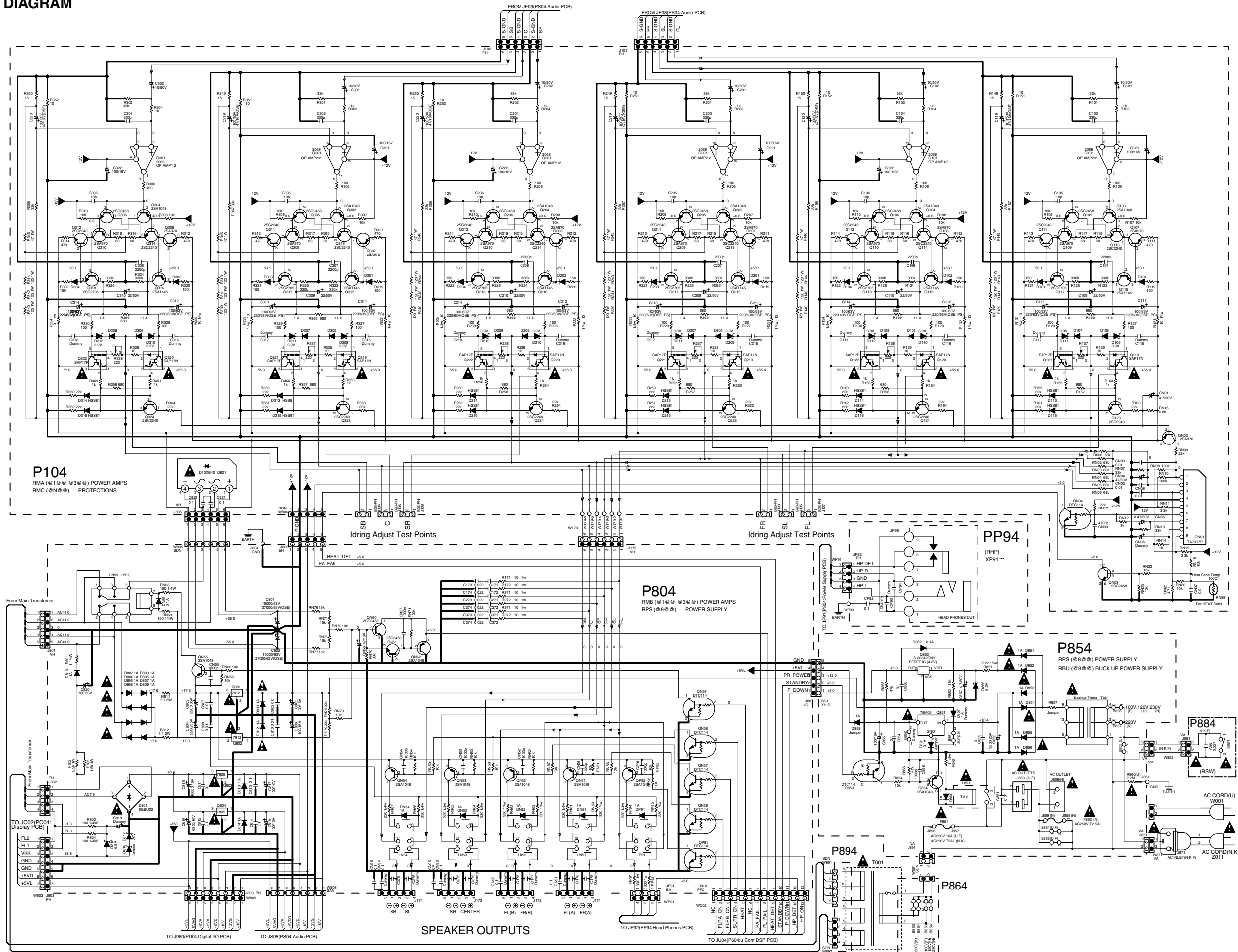

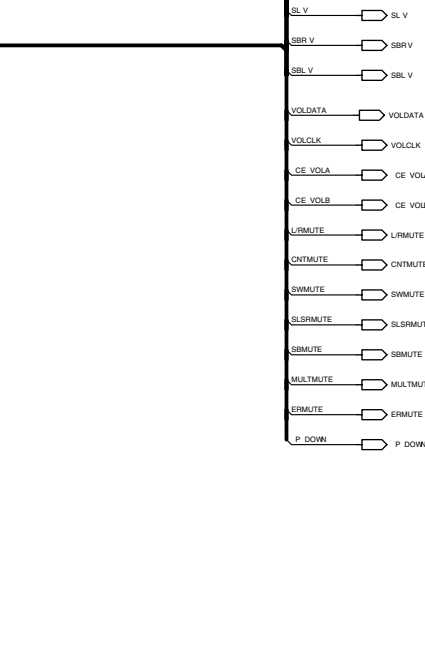
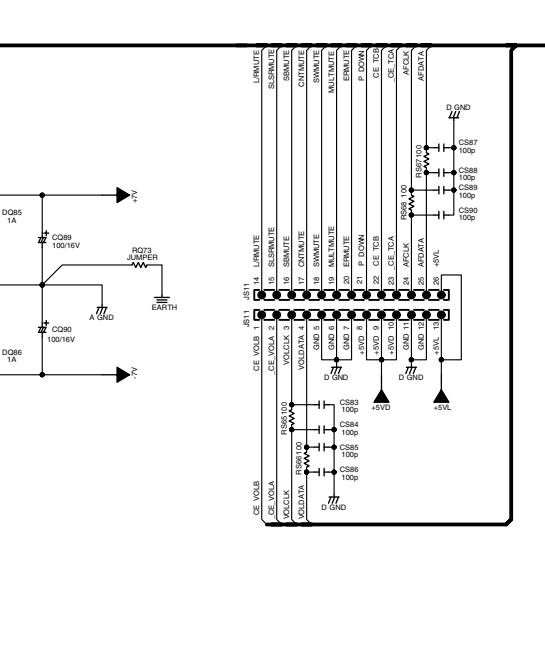
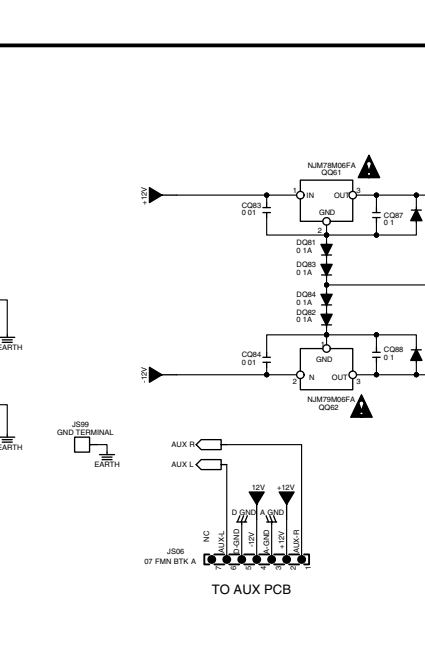
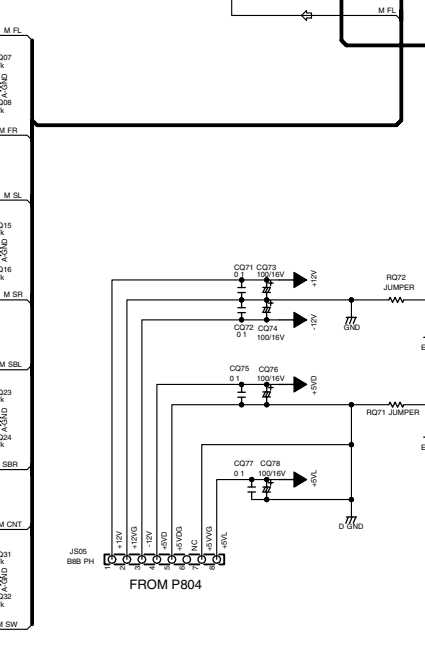
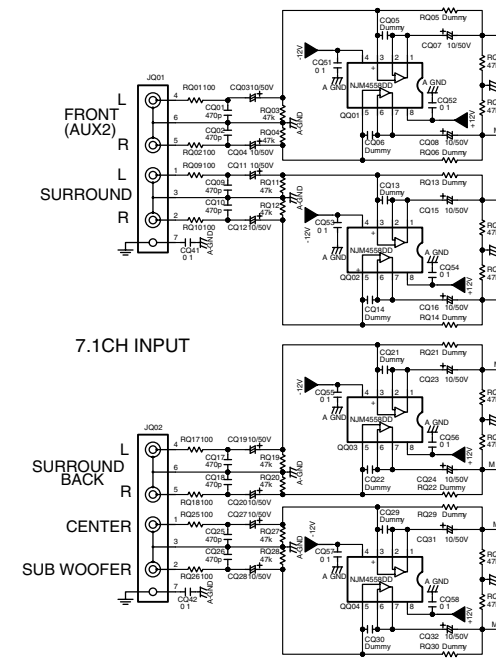
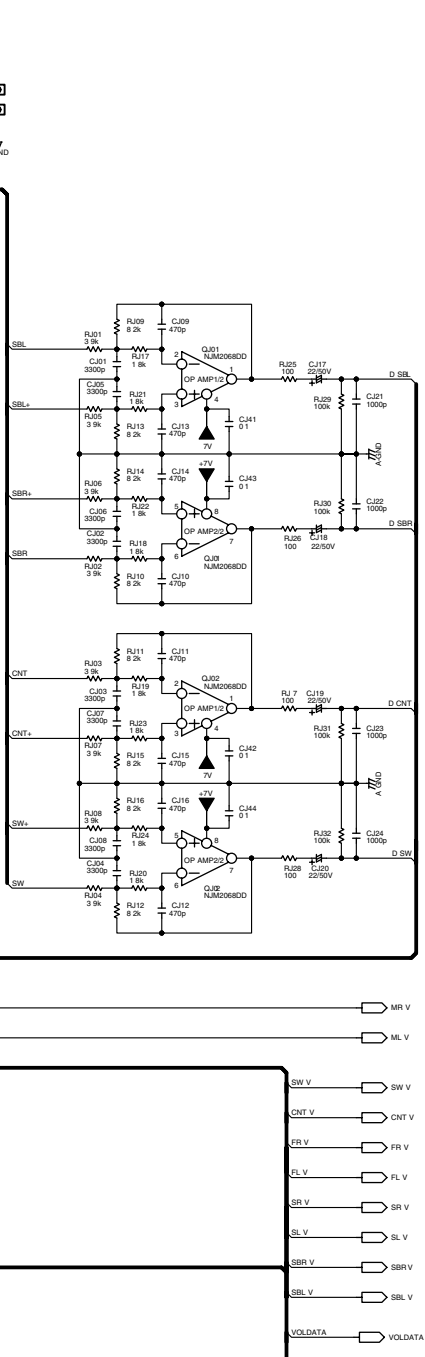
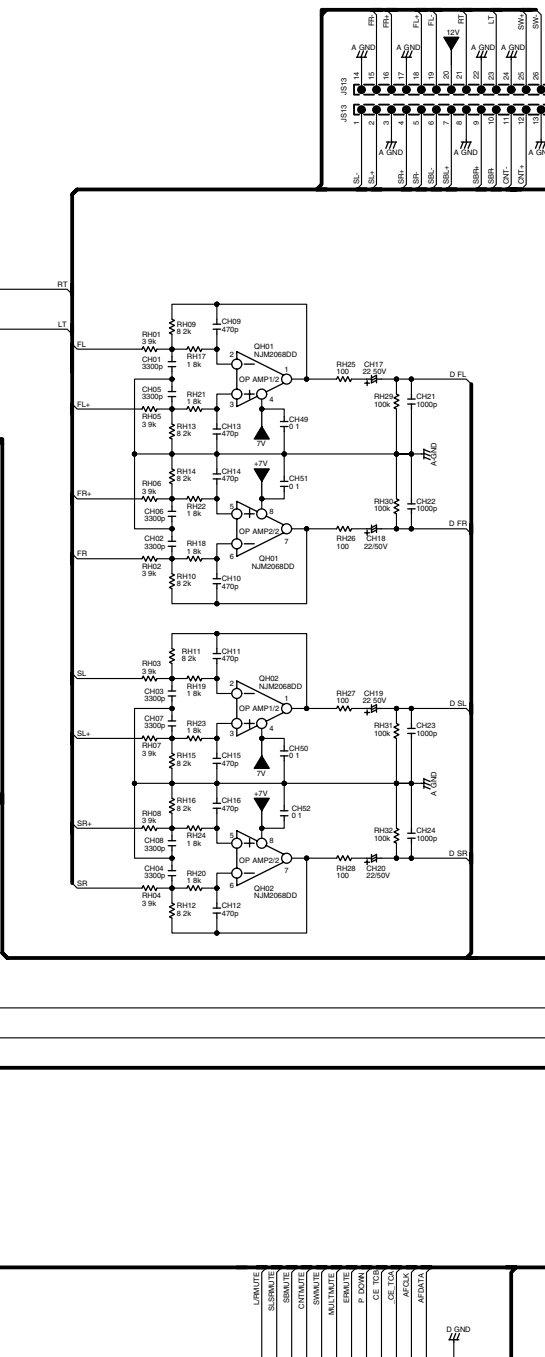
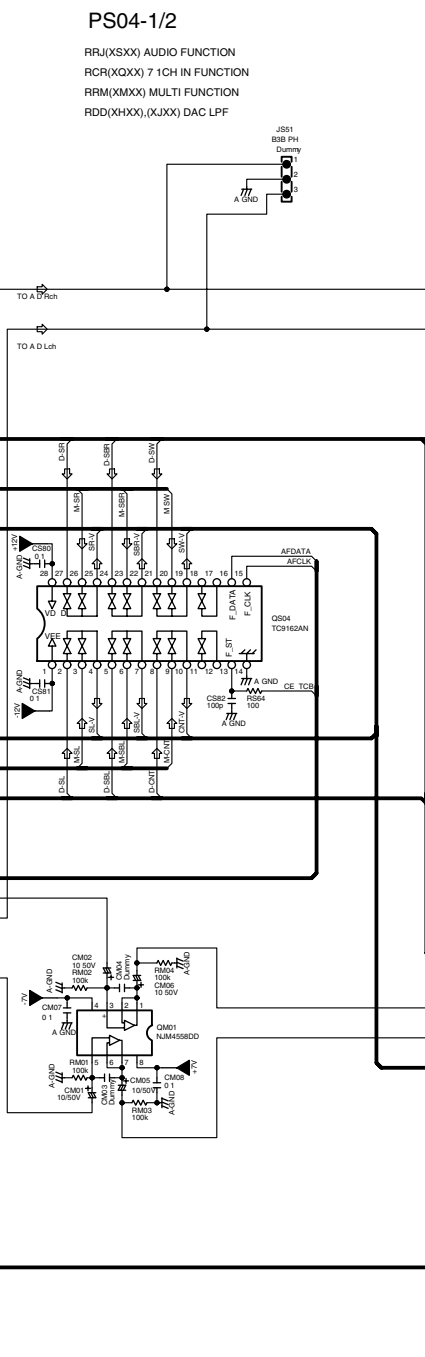
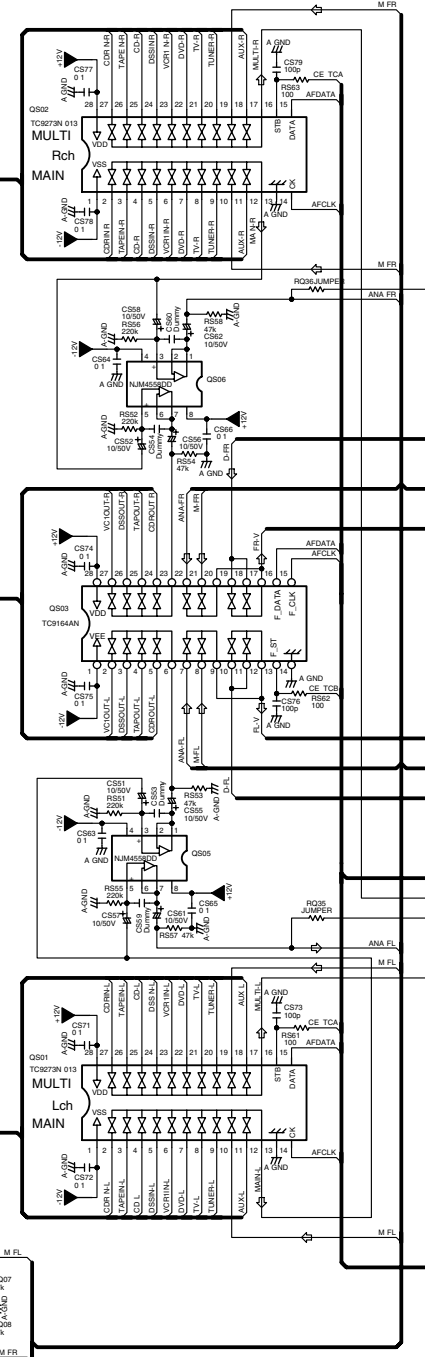
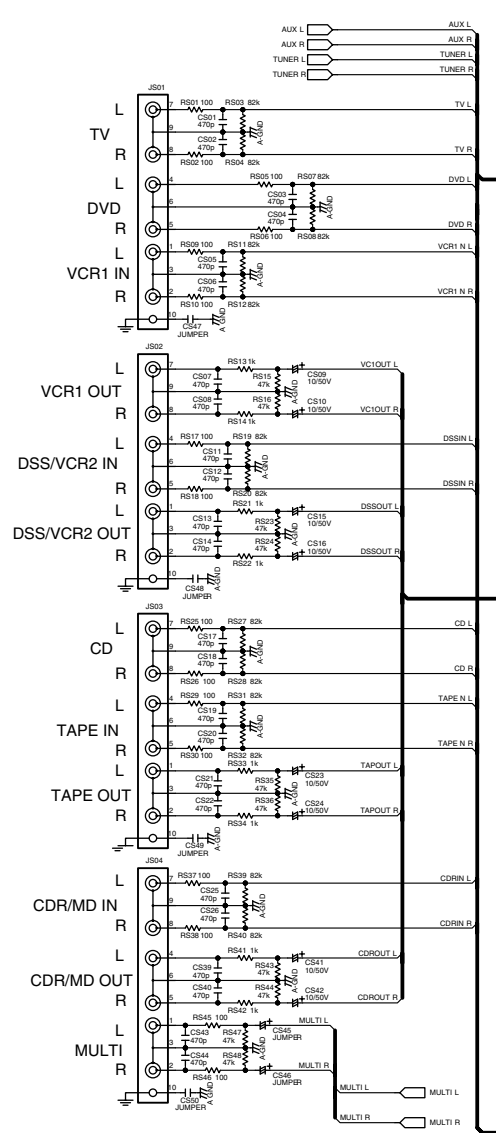

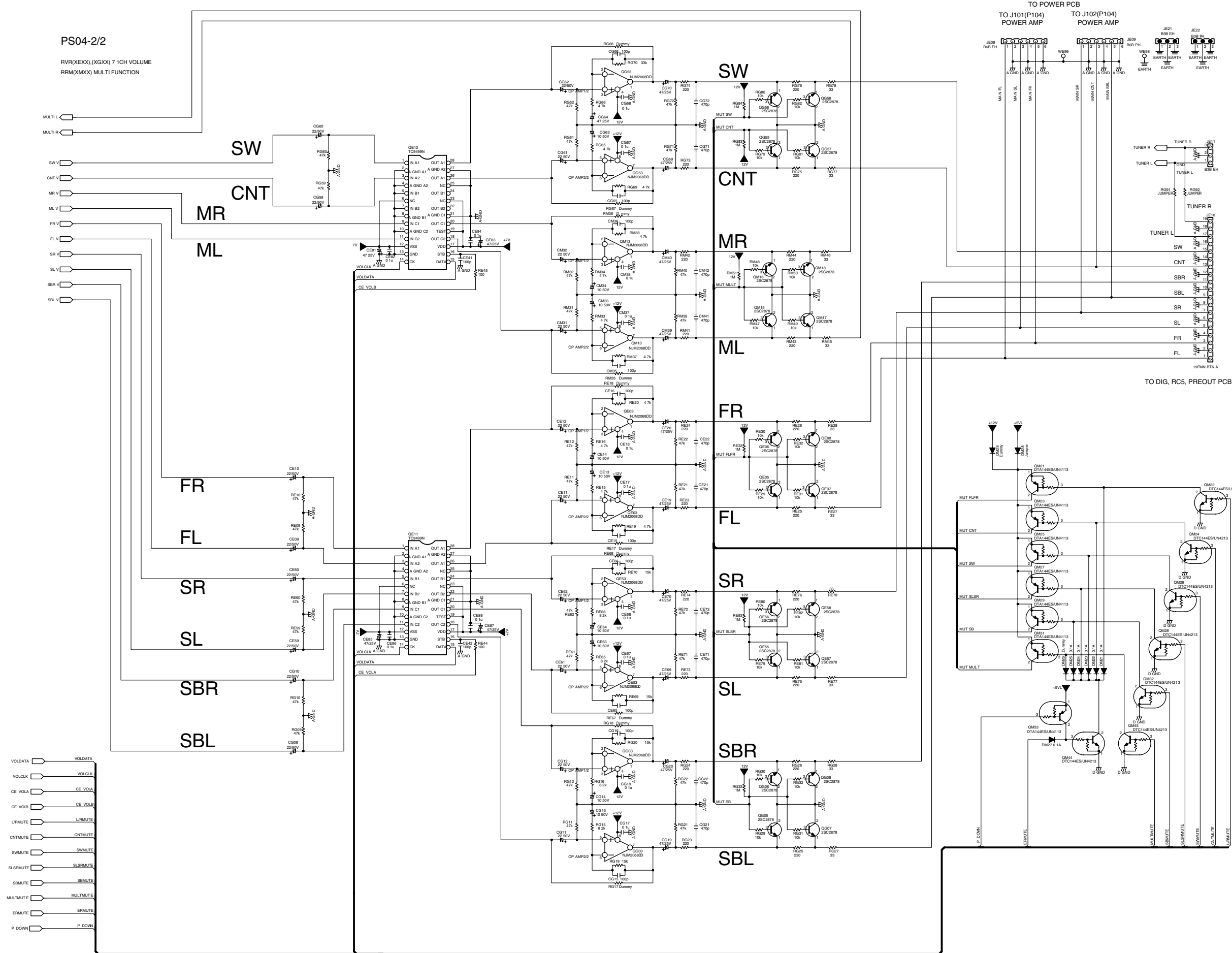

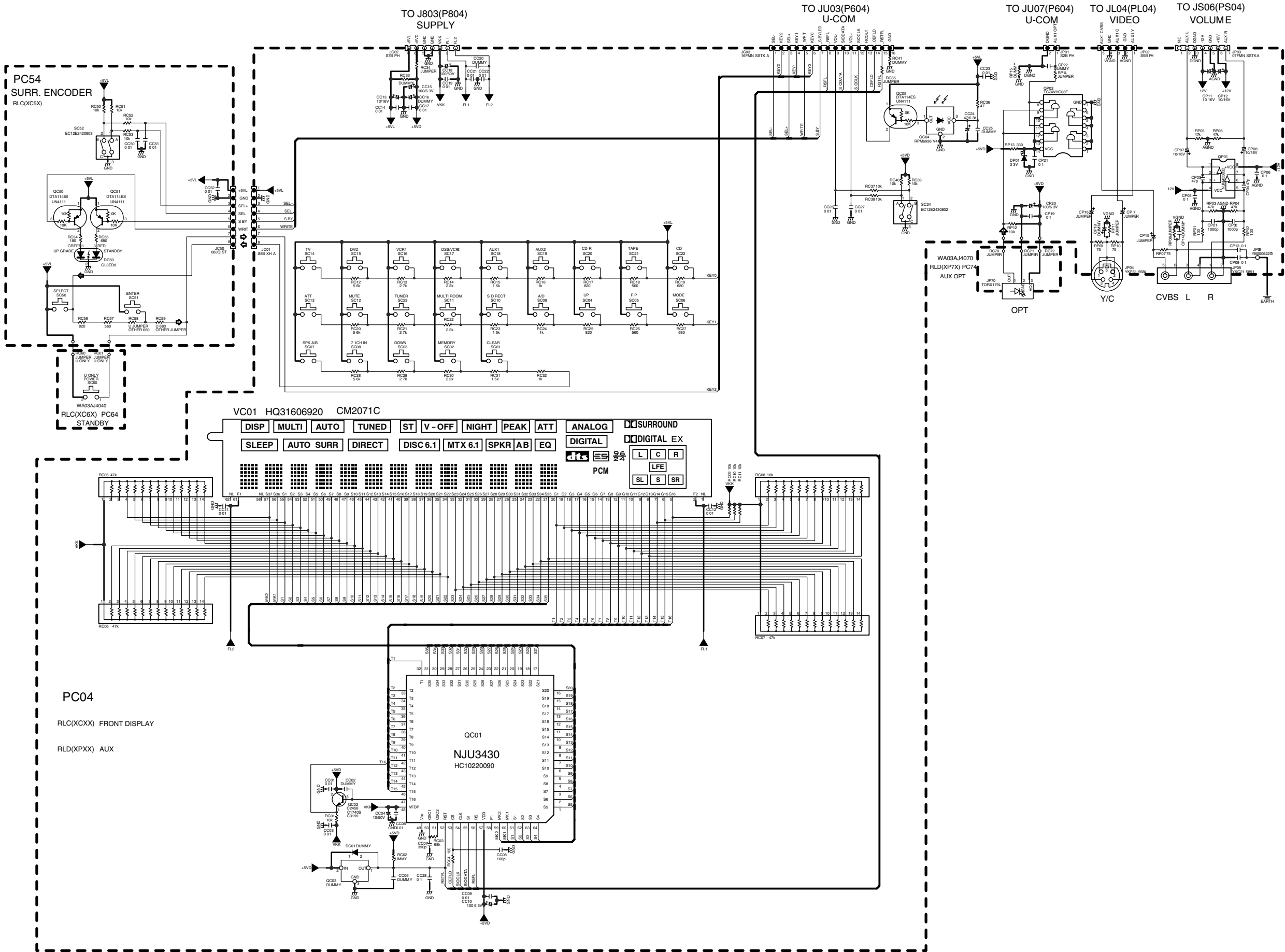

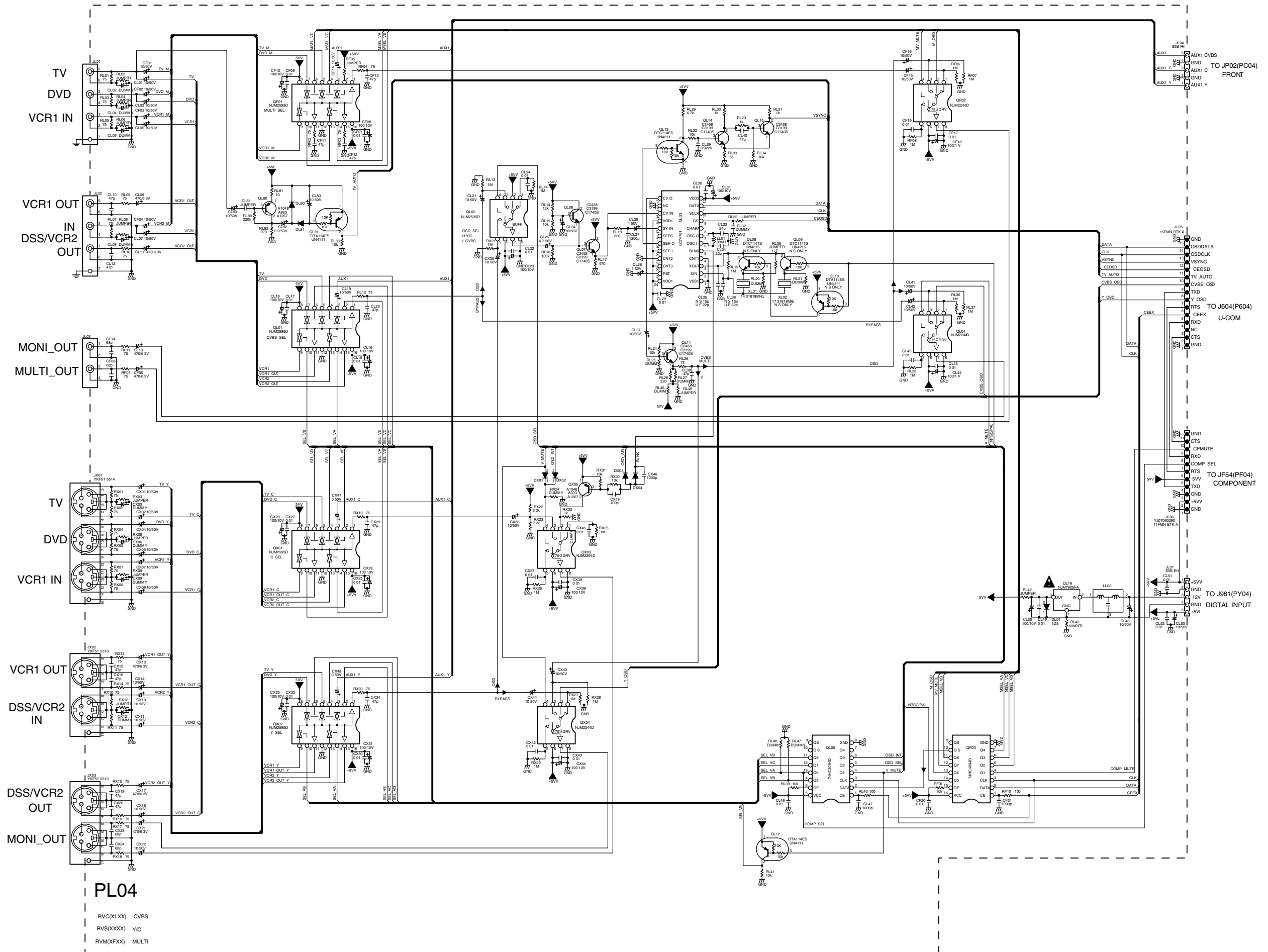

PL04

- RVC(XLXX) CVBS
- RVS(XXXX) Y/C
- RVM(XFXX) MULTI

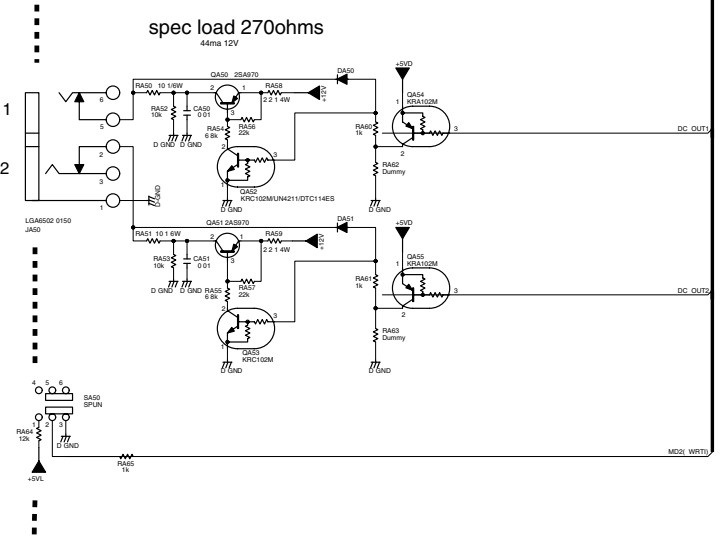
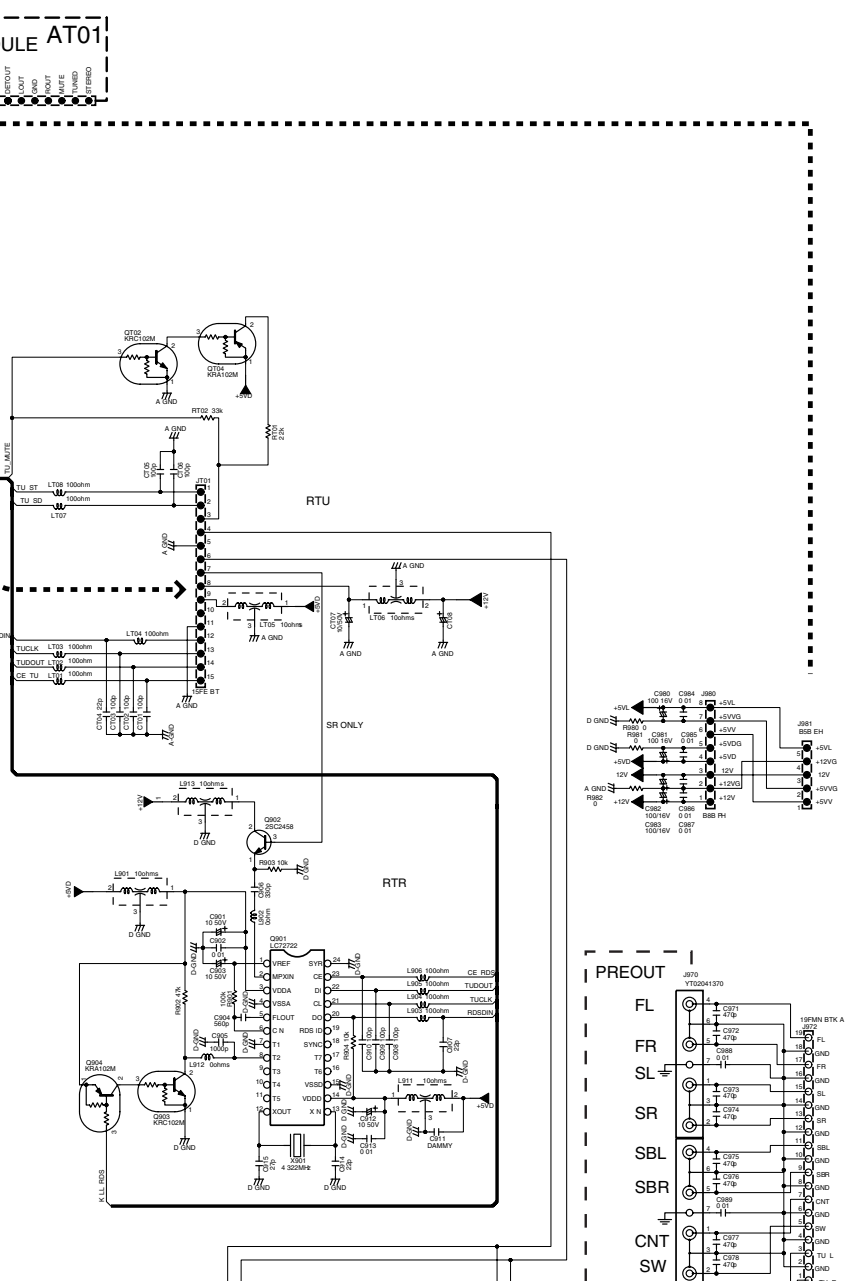
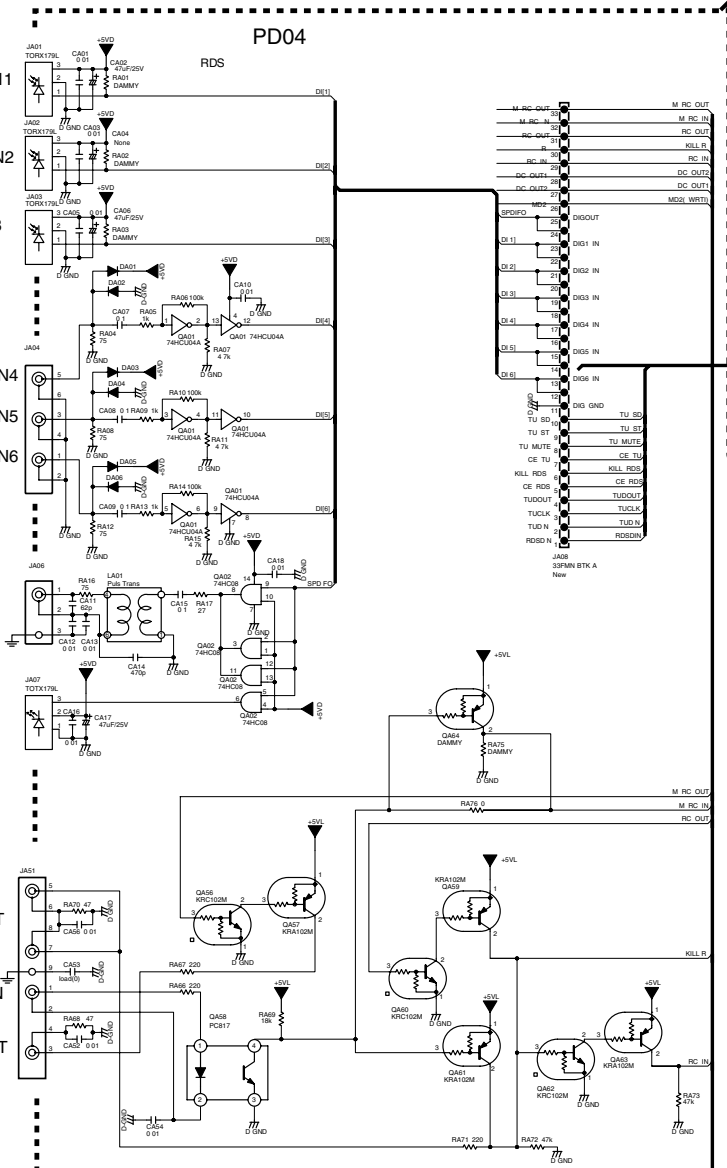
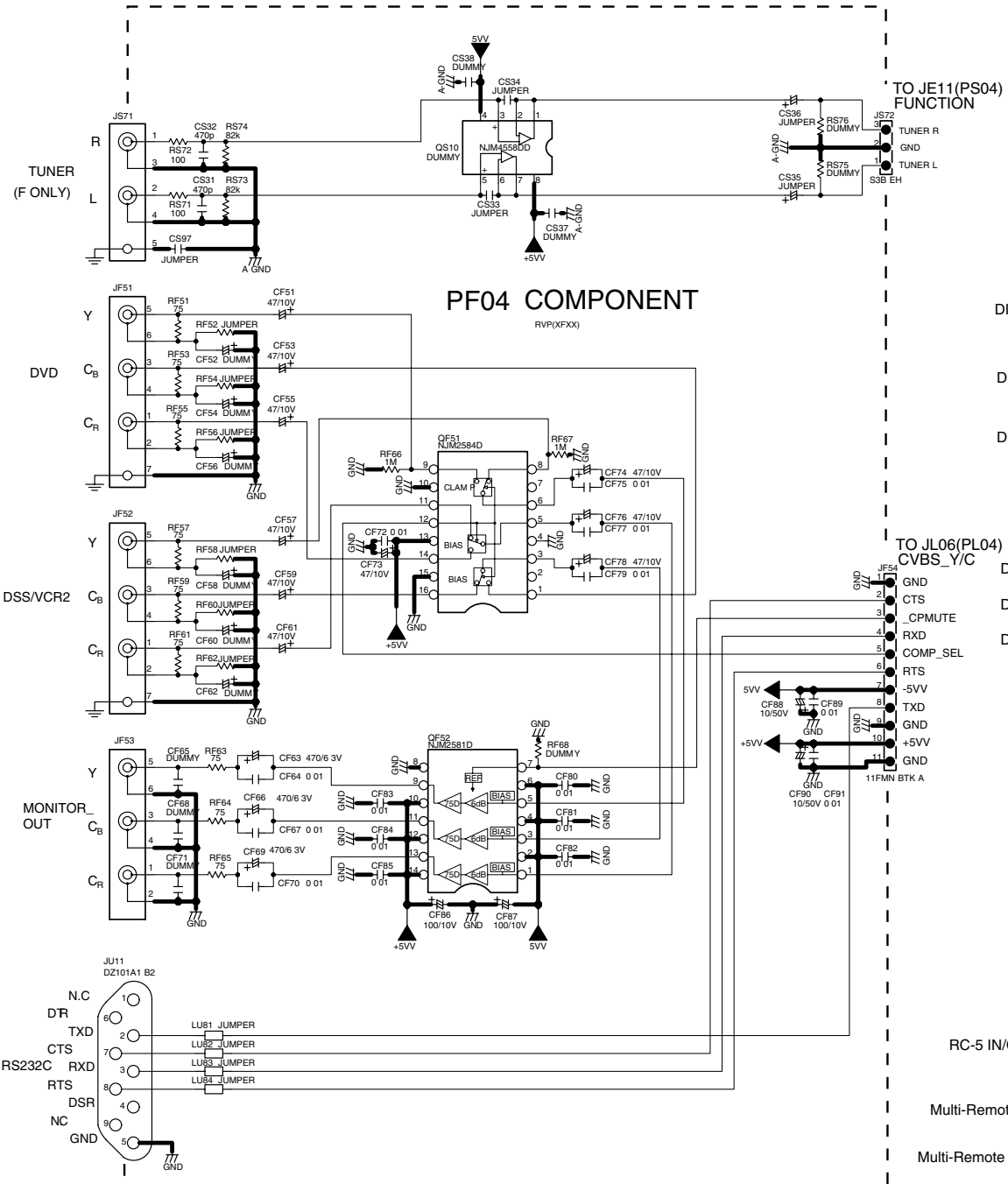

P604-1/2

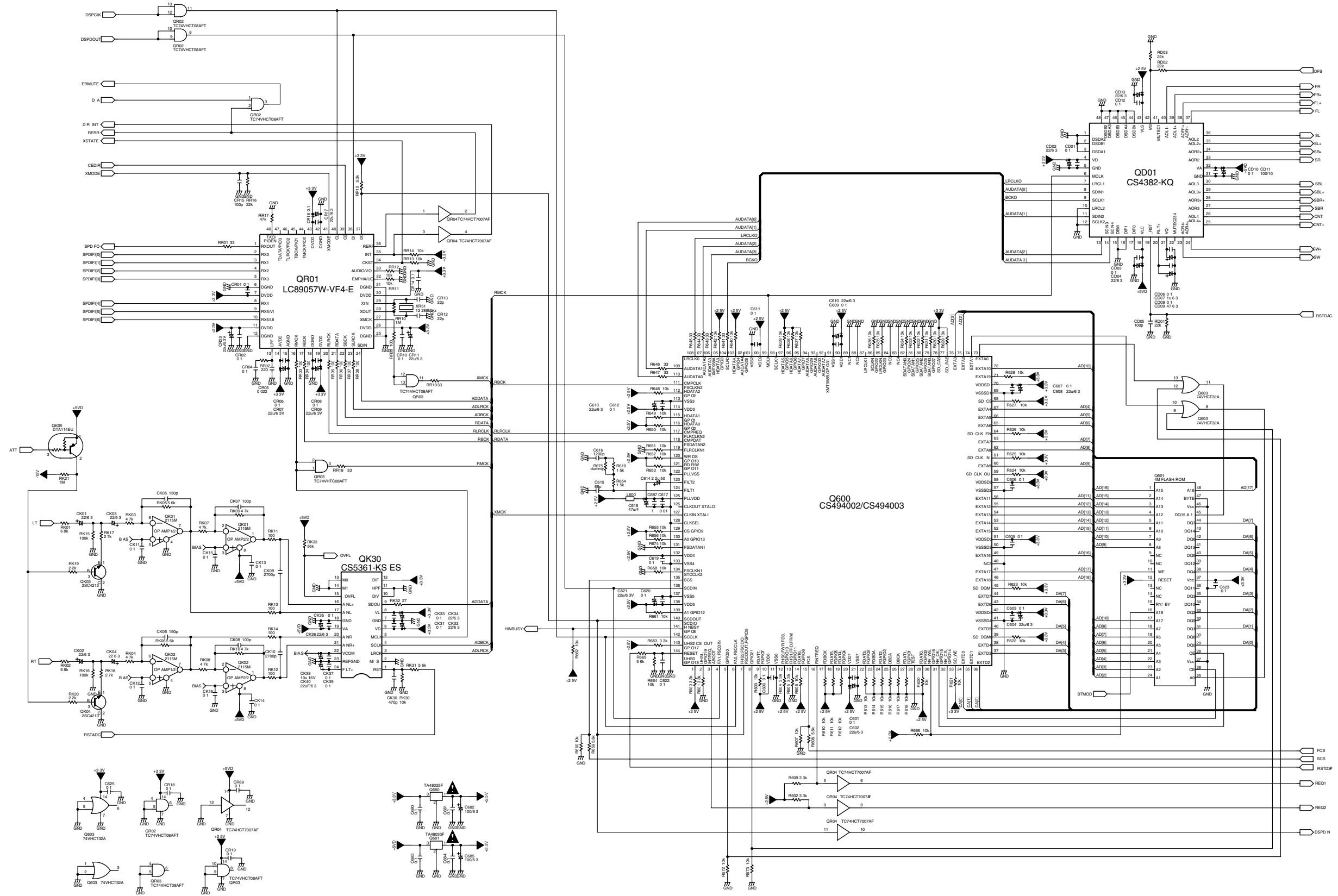

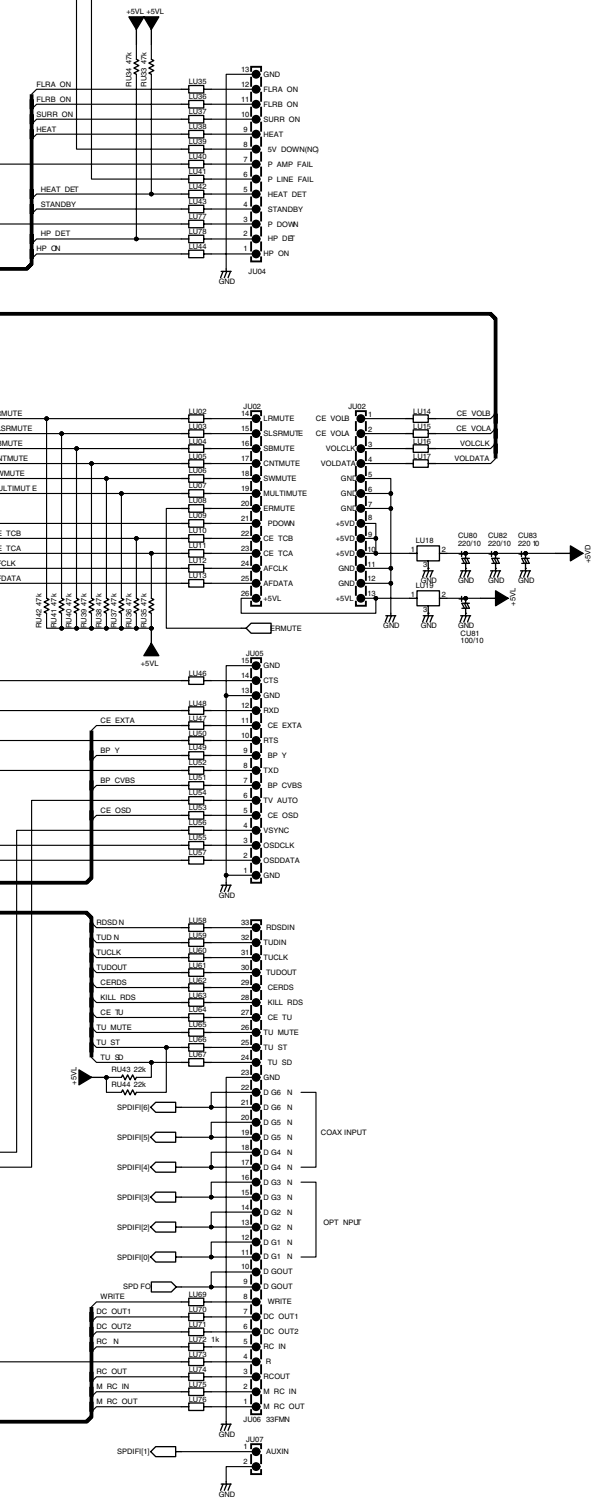
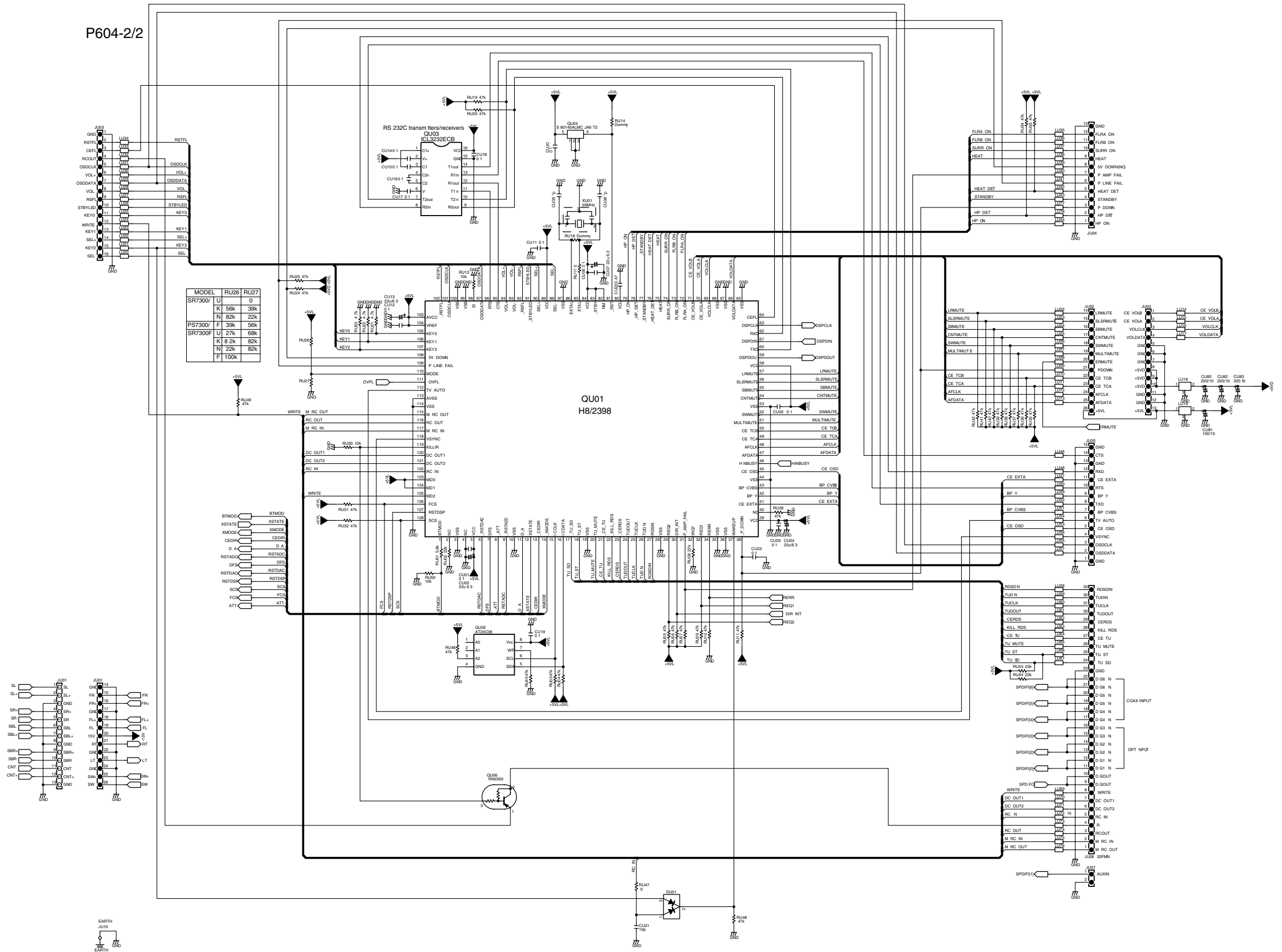

6. PARTS LOCATION

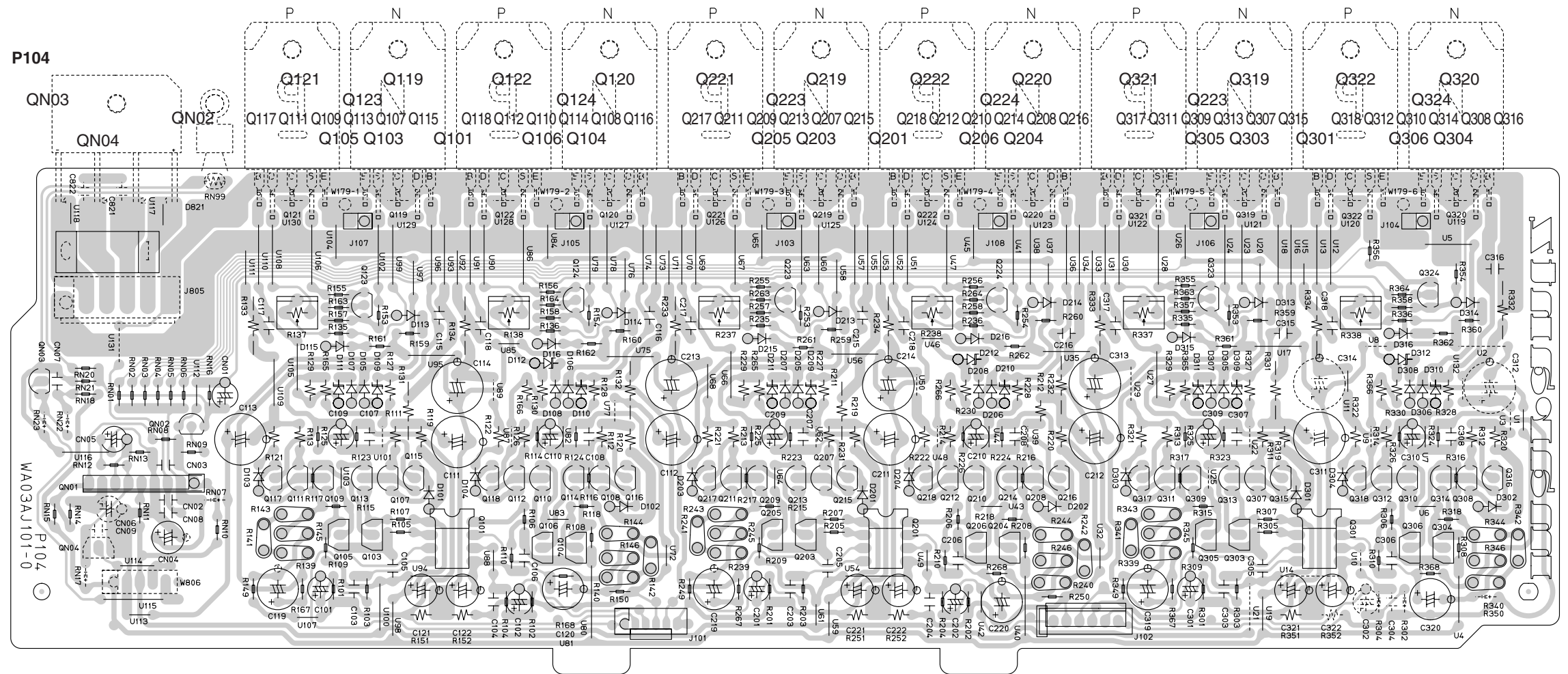

PD04

Q951 Q903 Q904 Q901
QA50 - QA55 QA59 - QA63 QA56 QA57 QA64 QA02 QA01

QT04 QT02

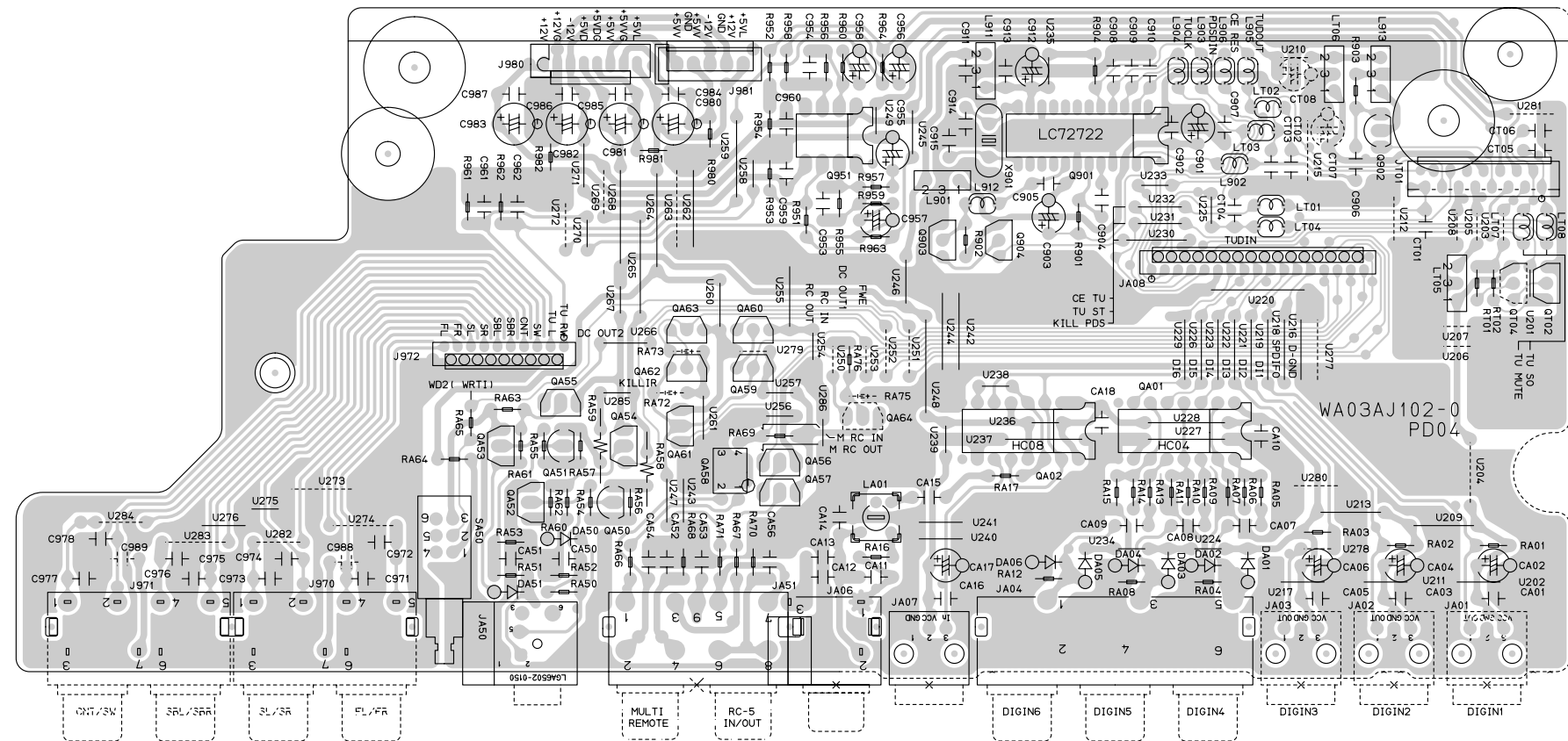

	QH01	QG58 - QG55	QG53	QE01	QM01	QS06	
	QH04	QM44 QM45 QM31 QM25 QM18 - QM18	QM13	QS04	QM01	QS03	
QJ01		QM26 QM24 QM23 QM29	QE03			QS05	
QJ02		QM33 QM32 QM27 QM21	QE53	QE11		QS01	
	QG62 QG61	QM28 QM22	QG08 - QG05			QQ03 QQ04	QQ01 QQ02

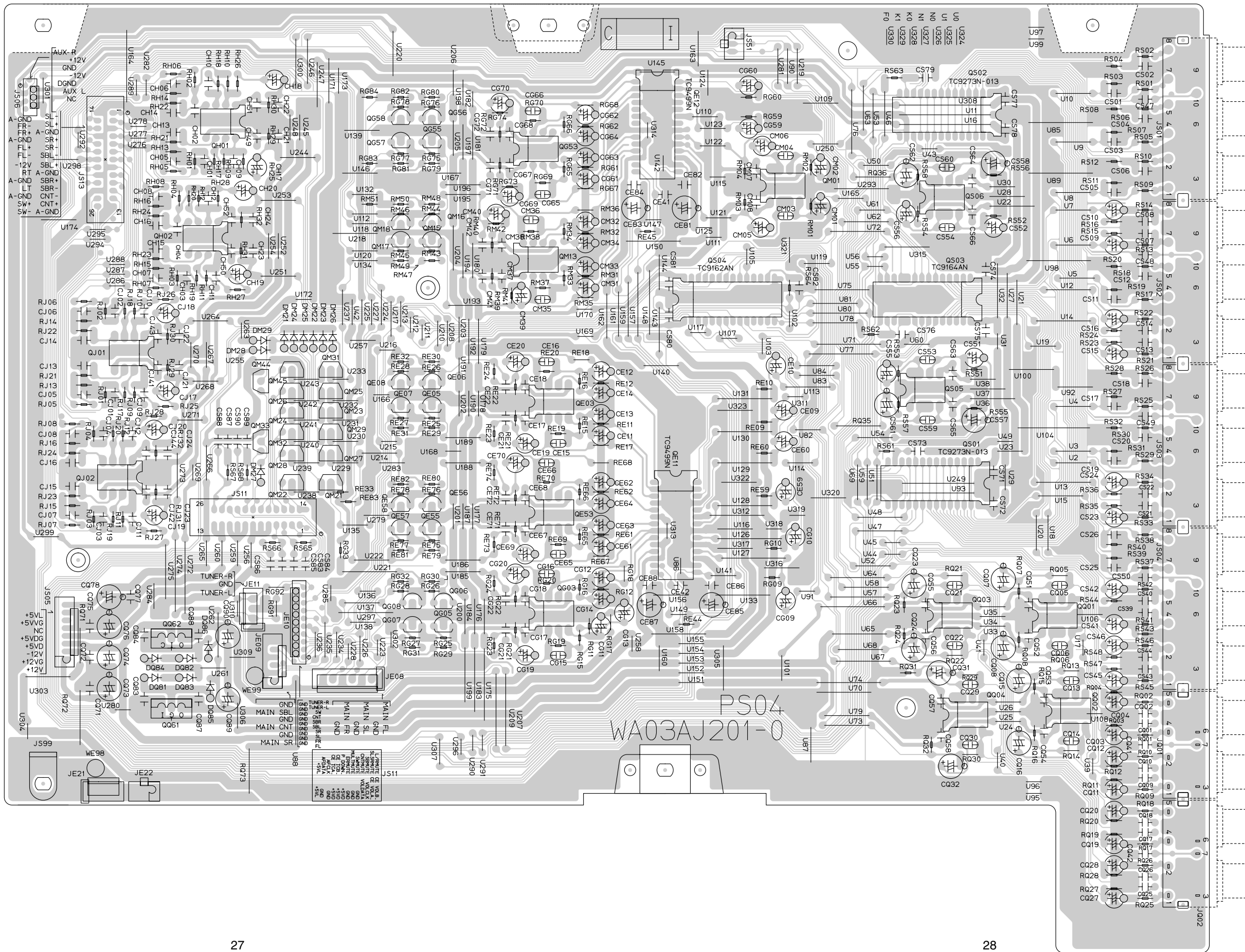

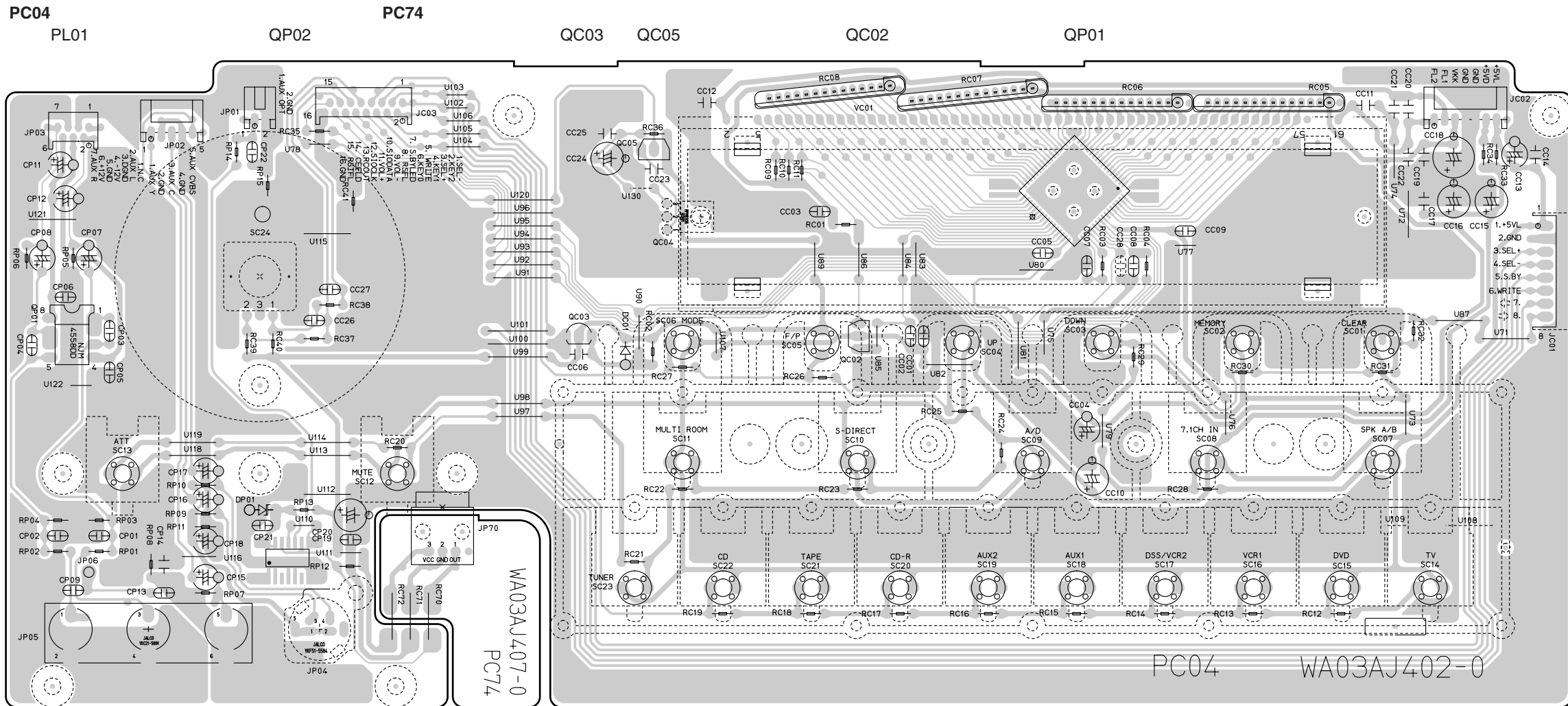
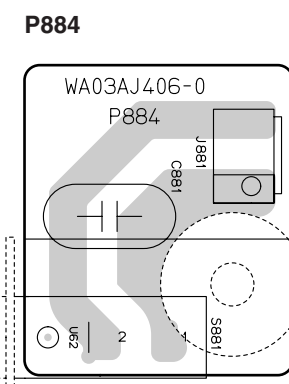
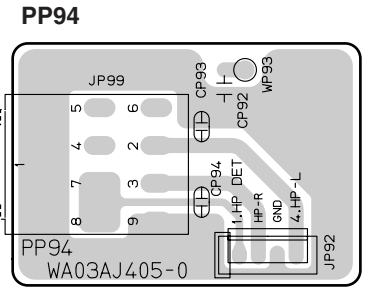
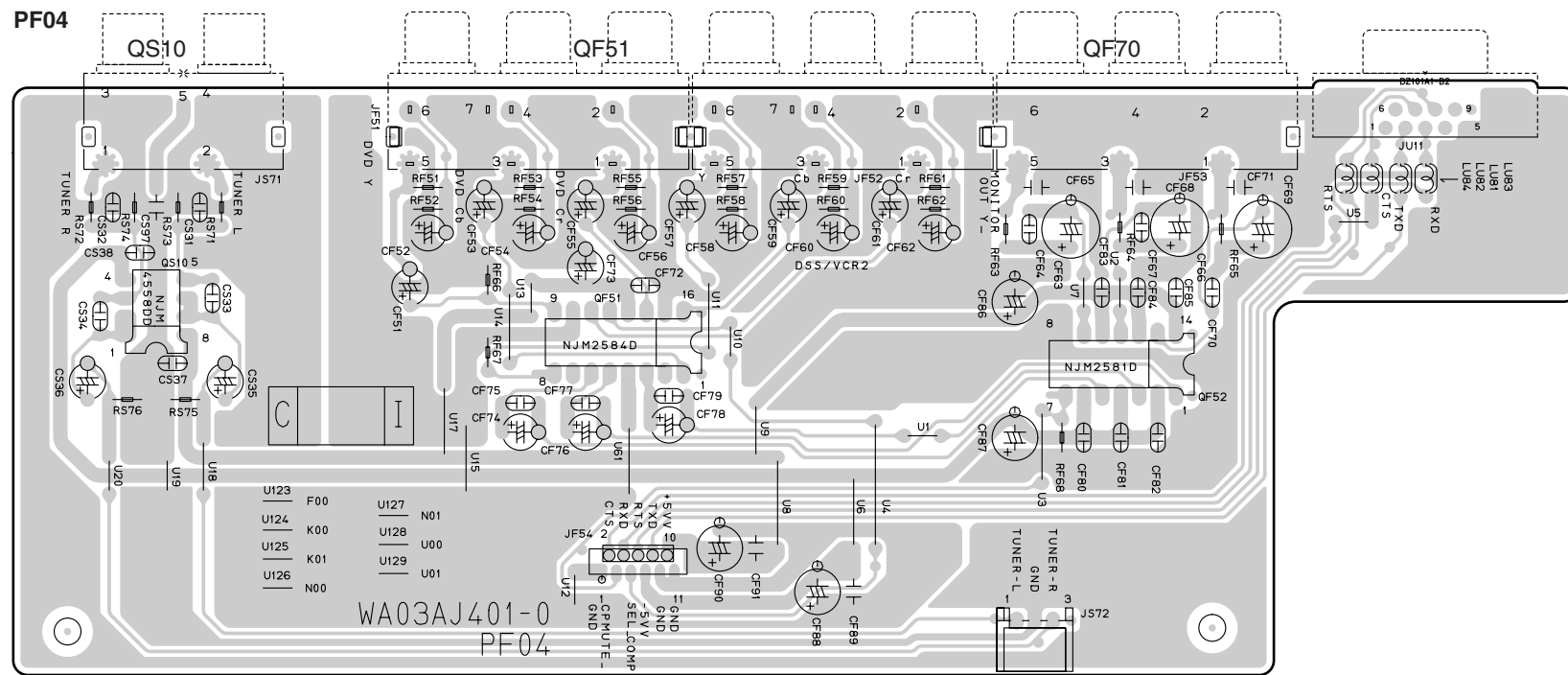

PL04

QL15 QL14 QL13 QL11 QL07 QL06 QF01 QL81 QL80
 QL08 QL09 QL03 QL02 QL01
 QL10 QX05 QL04
 QF03 QL05 QX03 QF02
 QL12 QX04 QX01
 QX02

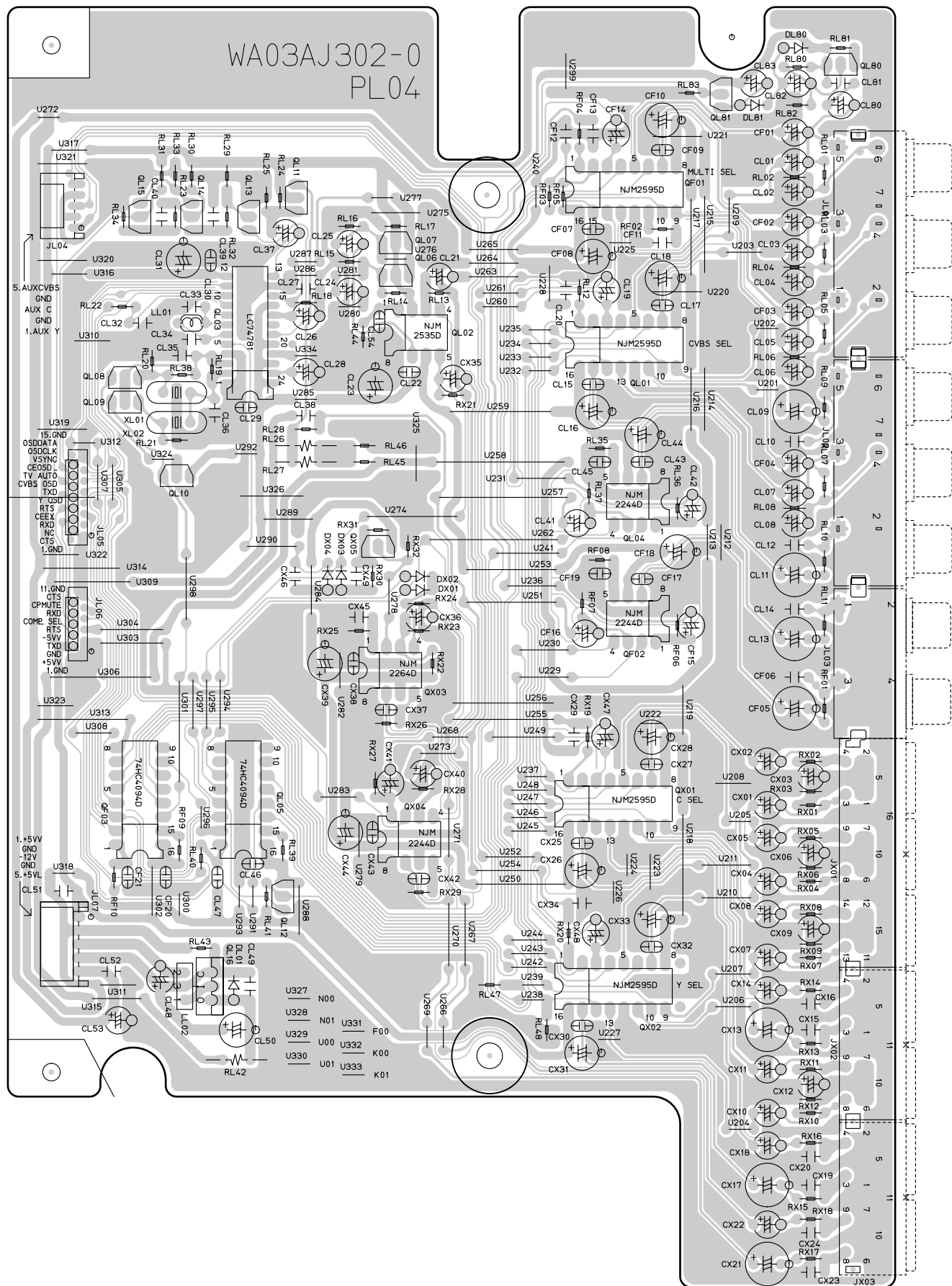

P804

Q803 Q804 Q801 Q802 QN60 - QN62 QN55 QN59
 QN51 - QN54 QN56 - QN58 QP91 QP92

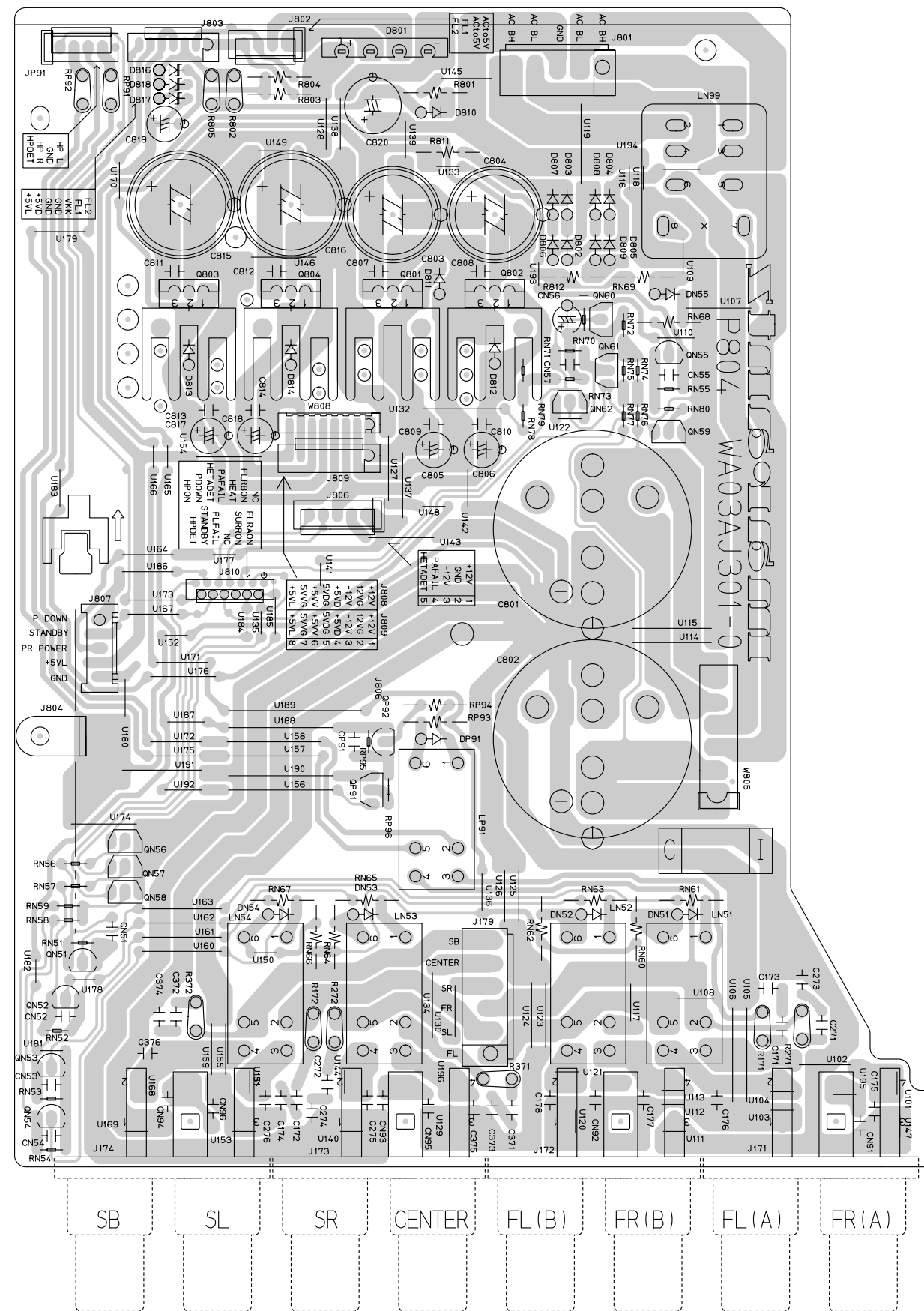

P854

Q854 Q852 Q823

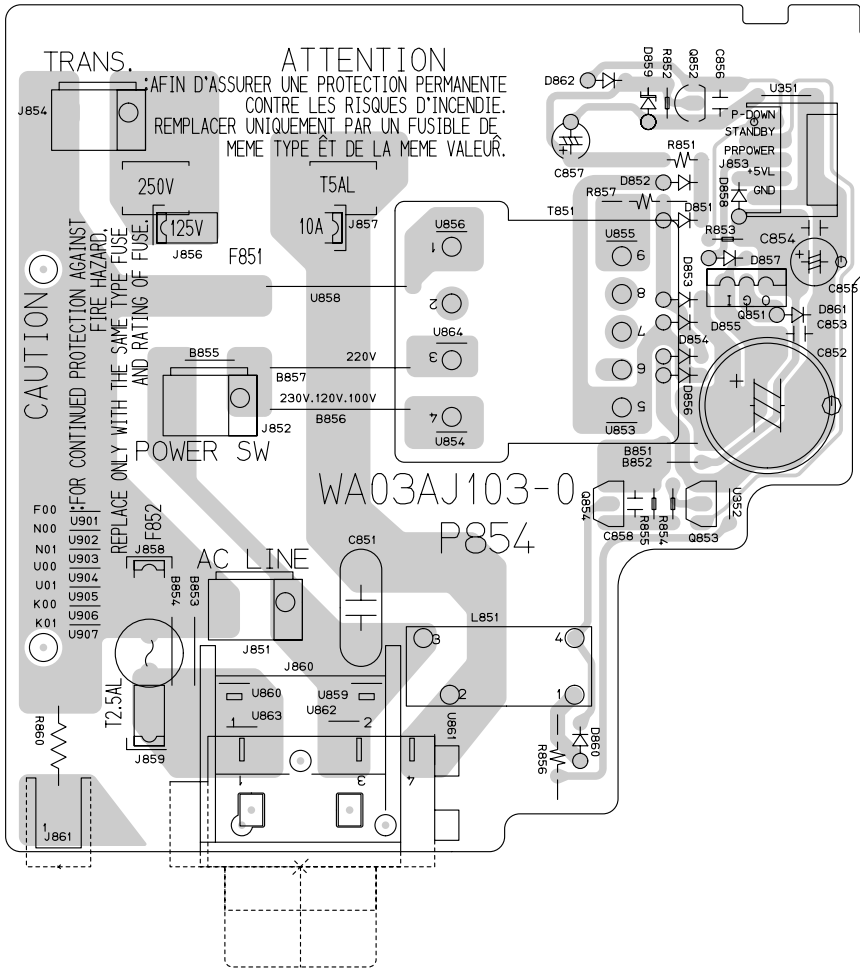

PC64

PC54

QC51 QC50

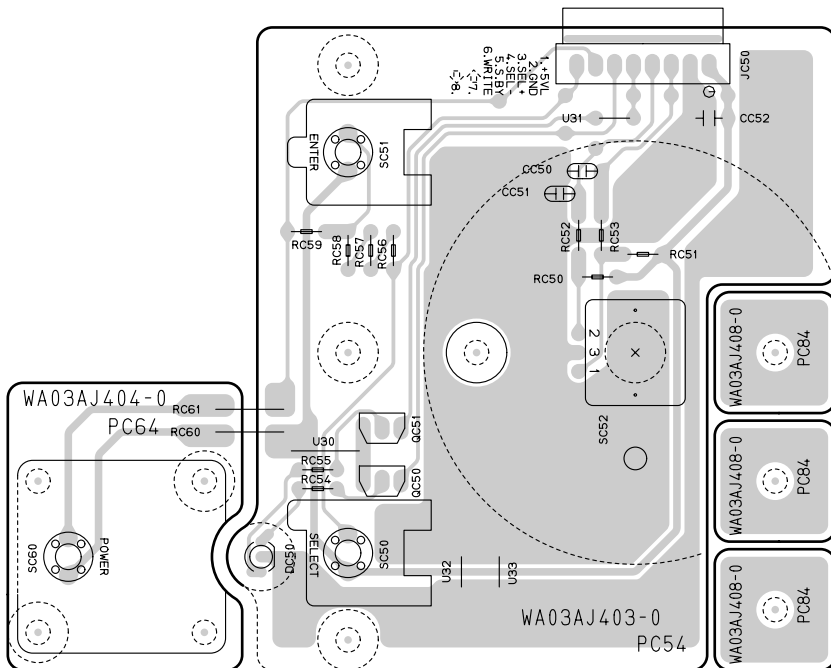

P874

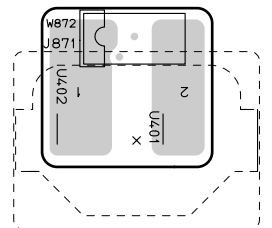

P864

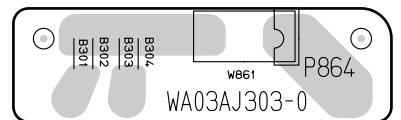

P894

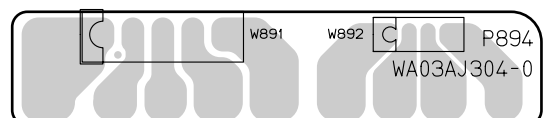

P604 A

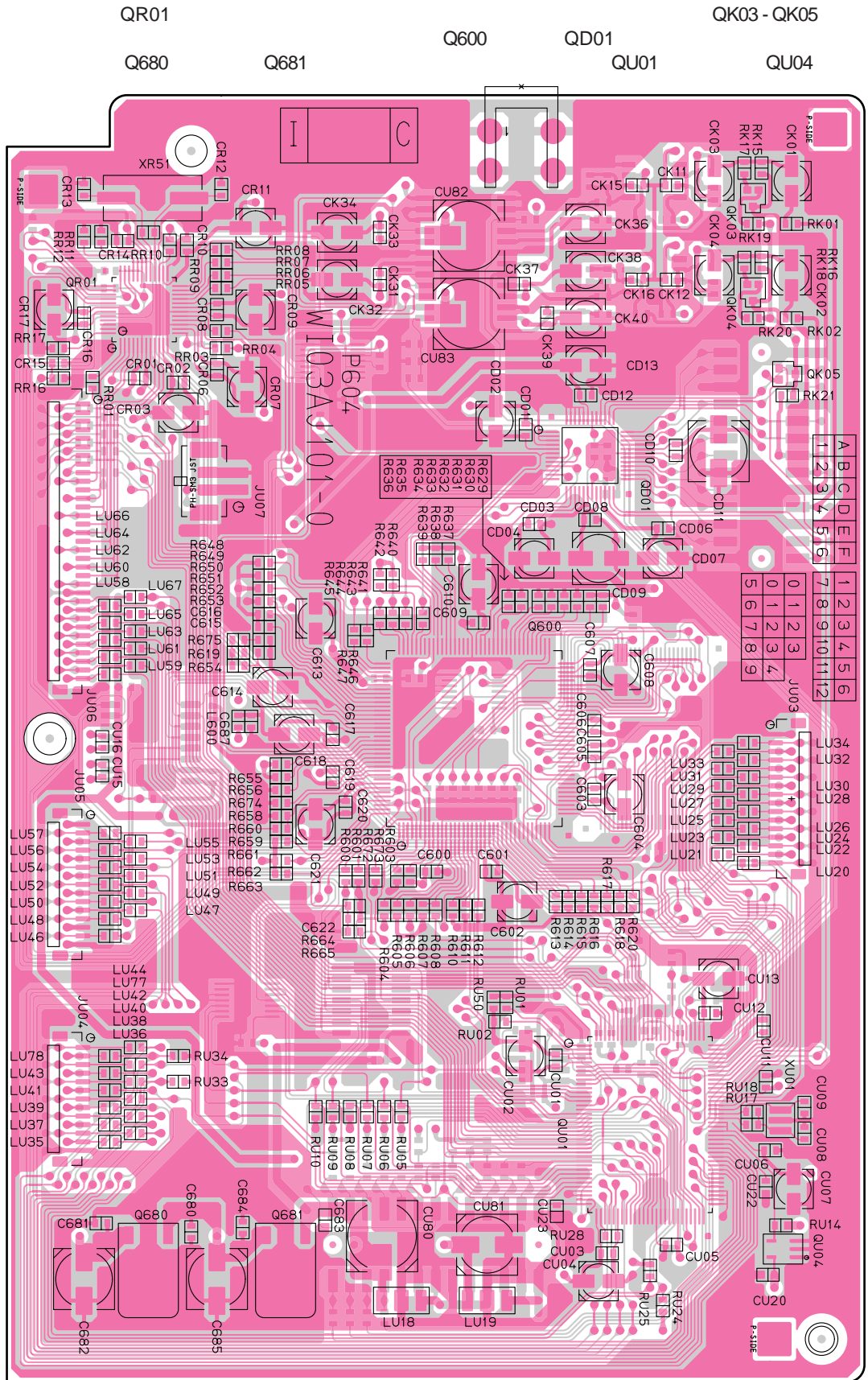

QR01

QK03 - QK05

Q600

QD01

Q680

Q681

QU01

QU04

A	B	C	D	E	F	1	2	3	4	5	6
1	2	3	4	5	6	7	8	9	10	11	12
0	1	2	3	4	5	6	7	8	9		

P604
W103AV101-0

P604 B

QU03 QR02 QR04 QU02 QU06
 QR03 Q603 Q601
 QK03 QK02 QK01

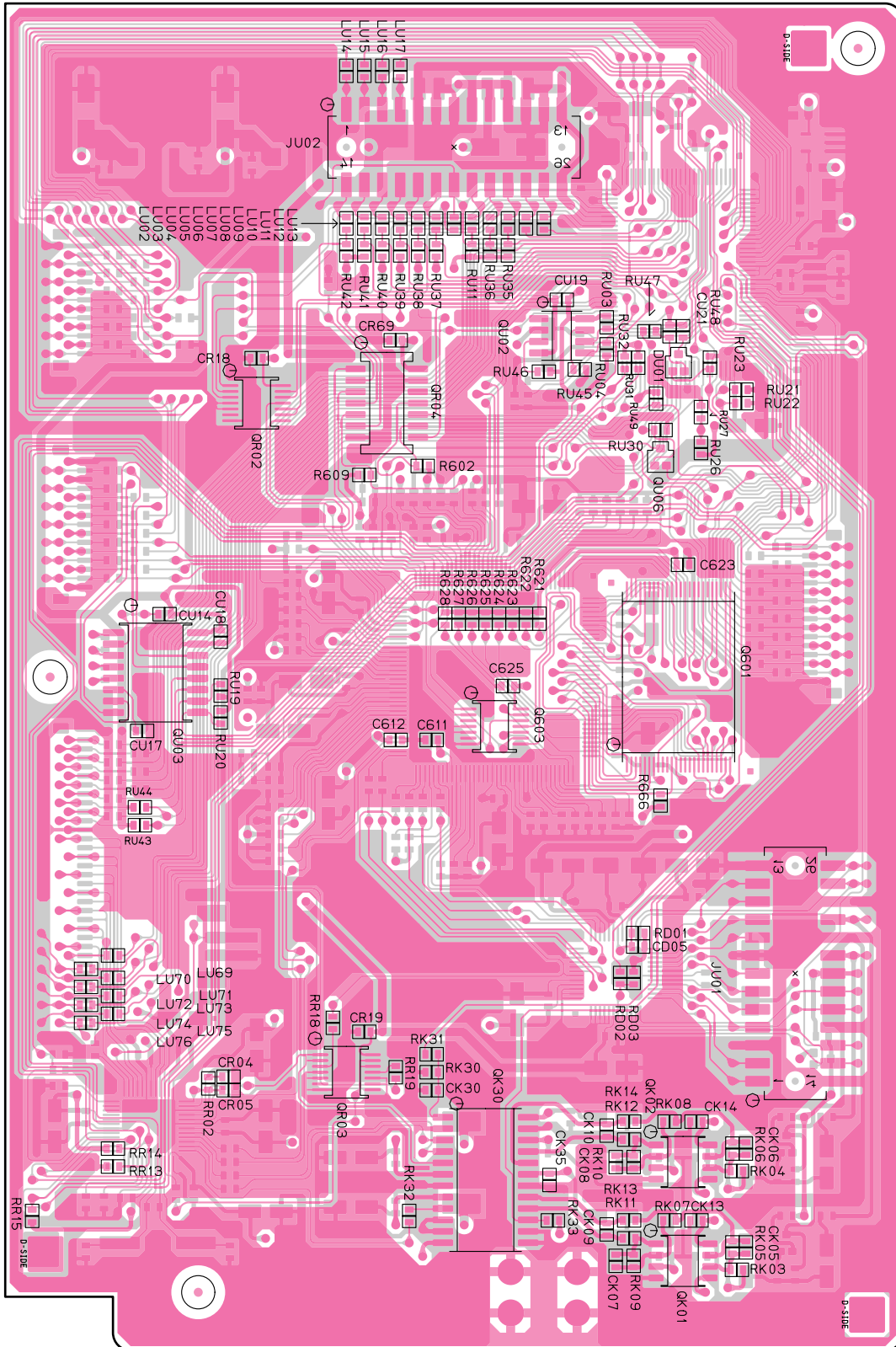

7. IC DATA

QU01 : H8S/2398F-ZTAT

Pin	I/O	Name	Port Act.	Note
1	O	BTMOD	L	FLASH ROM Address (A18)
2	I	N.C	-	PULL DOWN
3	-	VSS	-	GND
4	NC	NC		GND
5	I	Vcc	-	
6	O	_RSTDAC	L	DAC
7	O	DFS	H	DAC&I(AD)C
8	O	_ATT	L	ADC
9	O	_RSTADC	L	ADC
10	-	VSS	-	GND
11	O	D_A	-	DIR or _ADC sel
12	I	XSTATE	-	DIR
13	O	_CEDIR	L	DIR CHIP ENABLE
14	O	_XMODE	L	DIR RESET
15	O	IICCLK	-	I2C for E2PROM
16	I/O	IICDATA	-	I2C for E2PROM
17	I	_TU_SD	L	Tuned
18	I	TU_ST	H	Stereo Tune/ MONO
19	-	VSS	-	GND
20	O	TU_MUTE	H	Tuner MUTE
21	O	_CE_TU	L	Tuner Pack
22	O	_KILL_RDS	L	Tuner Pack(RDS)
23	O	_CERDS	L	Tuner Pack(RDS)
24	O	TUDOUT	-	Tuner Pack
25	O	TUCLK	-	Tuner Pack
26	I	TUDIN	-	Tuner Pack
27	I	RDSDIN	-	Tuner Pack(RDS)
28	-	VSS	-	GND
29	I(INT)	REQ2	L	DSP FINTR EQ
30	I(INT)	DIR_INT		DIR INT OUTPUT
31	I(INT)	_P_AMP_FAIL	L	Power amp Detect
32	I	IRQ7	-	PULL DOWN
33	I(INT)	REQ1	L	DSP INTER Q
34	I(INT)	RERR	H	DIR ERROR
35	-	VSS	-	GND
36	-	VSS	-	GND
37	I(INT)	WAKEUP	↑	STANDBY MODE Release
38	I(INT)	_P_DOWN	L	Power Down Detect
39	I	Vcc	-	+5V
40	O	N.C	-	OPEN
41	O	_CEEX	L	P-Exp(Video)Sel A
42	O	Y_OSD	H	Y/C_OSD_IC_BYPASS
43	O	CVBS_OSD	H	CVBS_OSD_IC_BYPASS
44	-	VSS	-	GND
45	O	_CEOSD	L	Video Circuit
46	I	HINBSY	-	DSP Busy Signal
47	O	AFDATA	-	Analog Switch DATA
48	O	AFCLK	-	Analog Switch CLOCK
49	O	CE_TCA	H	Analog Switch TC9273
50	O	CE_TCB	H	Analog Switch TC9262/9264
51	O	MULTIMUTE	H	MULTI ROOM MUTE
52	O	SWMUTE	H	SUB W MUTE
53	-	VSS	-	GND
54	O	CNTMUTE	H	CENTER SP MUTE
55	O	SBMUTE	H	SRR B MUTE
56	O	SL/SRMUTE	H	SL SR MUTE
57	O	L/RMUTE	H	FRONT L R MUTE
58	I	Vcc	-	+5V
59	O(SO)	DSPDOUT		DSP DIR Control Data OUT
60	O(SO)	TXD		UART for Panja, Flash WR
61	I(SI)	DSPDIN		DSP DIR Control Data IN
62	I(SI)	RXD		UART for Panja, Flash WR

63	O(SC)	DSPCLK		DSP DIR Control CLOCK
64	O	_CEFL	L	FL Driver chip sel
65	-	VSS	-	GND
66	O	VOLDATA	-	Volume IC DATA
67	-	VSS	-	GND
68	-	VSS	-	GND
69	O	VOLCLK	-	Volume IC CLOCK
70	O	CE_VOLA	H	Volume IC Chip Sel A
71	O	CE_VOLB	H	Volume IC Chip Sel B
72	O	FLRA_ON	H	SPK A SELECT
73	O	FLRB_ON	H	SPK B SELECT
74	O	SURR_ON	H	SURR/CNT/SB SPK ON
75	O	HEAT	H	Power Amp ±B_L_Sel
76	I	_HEAT_DET	H	Power Amp Heat sink Temp Detect
77	O	_STANDBY	L	Standby Power
78	I	_HP_DET	L	HP Jack Detect
79	O	HP_ON	H	HEAD PHONE ON
80	-	VCL	-	
81	I	_RST	L	Reset
82	NO	NMI	-	Fix H
83	NO	_STBY	L	Fix H
84	I	Vcc	-	+5V
85	O	XTAL	-	Xtal(20M)
86	I	EXTAL	-	Xtal(20M)
87	-	VSS	-	GND
88	I	SEL-	-	Front Select. Encoder
89	I	Vcc	-	+5V
90	I	SEL+	-	Front Select. Encoder
91	O	_STBY LED	L	Standby LED On
92	O	_RSFL	L	Front FL Driver
93	I	VOL-	-	Front Vol. Encoder
94	I	VOL+	-	Front Vol. Encoder
95	I	CTS	-	UART
96	O	RTS	-	UART
97	O(SO)	OSDDATA	-	Front FL & Video(OSD)
98	I	N.C	-	PULL DOWN
99	-	VSS	-	GND
100	-	VSS	-	GND
101	O(SC)	OSDCLK	-	Front FL & Video(OSD)
102	O	_RSTFL	L	Reset FL Driver
103	-	AVCC	-	+5V
104	-	VREF	-	+5V
105	I(AD)	KEY0	-	Front Key
106	I(AD)	KEY1	-	Front Key
107	I(AD)	KEY2	-	Front Key
108	I(AD)	_5V_DOWN	-	Detect 5V
109	I(AD)	P_LINE_FAIL	-	Emergency Protection
110	I(AD)	MODE	-	CPU mode
111	I	_OVFL	H	Peak Indicator
112	I(AD)	TV_AUTO	H	TV Video Detect
113	-	VSS	-	GND
114	-	VSS	-	GND
115	O	M_RC_OUT		RC BUS MULTI OUTPUT
116	O	RC_OUT		RC BUS OUTPUT
117	I	M_RC_IN	L	Multi RC5 IN Detect Signal
118	I	VSYNC	↑	V-sync Det. & Change OSD
119	O	KILLIR	H	Kill to IR input signal.
120	O	DC_OUT1	L	DC Triger1
121	O	DC_OUT2	L	DC Triger2
122	I	RC_IN	↑↓	IR In for RC-5
123	I	MD0	-	+5V
124	I	MD1	-	Fix H
125	I	MD2	-	Normal :H, Boot :L
126	O	_FCS	L	DSP CHIP ENABLE
127	O	_RSTDSP	L	DSP
128	O	_SCS	L	DSP CHIP ENABLE

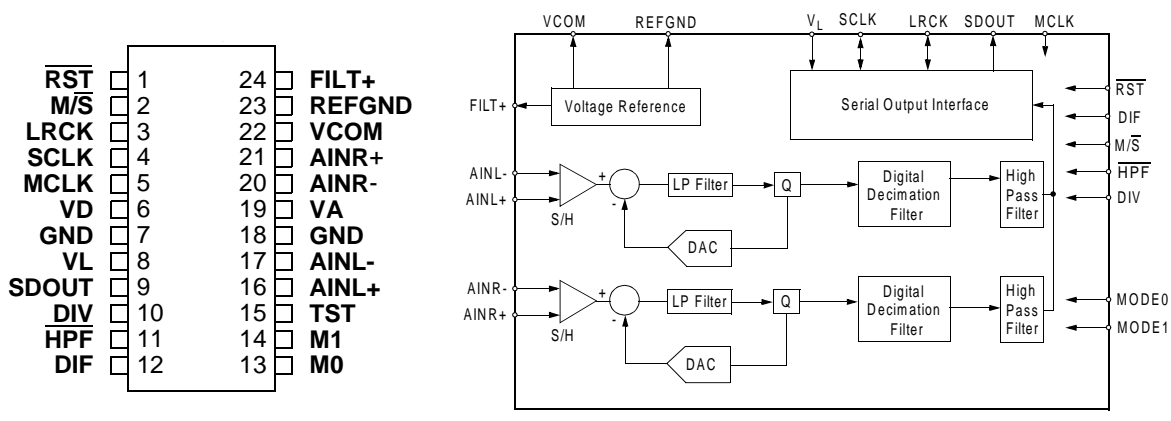

Pin Name	I/O	#	Pin Description
$\overline{\text{RST}}$	I	1	Reset (Input) - The device enters a low power mode when low.
$\overline{\text{M/S}}$	I	2	Master/Slave Mode (Input) -In Slave mode, LRCK and SCLK become input. (FIXED LOW)
LRCK	I	3	Left Right Clock (Input) - Determines which channel, Left or Right, is currently active on the serial audio data line. The frequency of the left/right clock must be at the audio sample rate, Fs.
SCLK	I	4	Serial Clock (Input) - Serial clock for the serial audio interface.
MCLK	I	5	Master Clock (Input) - Clock source for the delta-sigma modulator and digital filters. Table 1 illustrates several standard audio sample rates and the required master clock frequency.
VD	I	6	Digital Power (Input) - Positive power supply for the digital section. Refer to the Recommended Operating Conditions for appropriate voltages.
GND	I	7,18	Ground (Input) - Ground reference. Must be connected to analog ground.
VL	I	8	Logic Power (Input) - Determines the required signal level for the digital input/output. Refer to the Recommended Operating Conditions for appropriate voltages.
SDOUT	O	9	Serial Audio Data Output (Output) - Output for two's complement serial audio data.
DIV	I	10	MCLK Divider (Input) - (FIXED LOW)
HPF	I	11	High Pass Filter Enable (Input) - The device includes a high pass filter after the decimator to remove the indeterminate DC offsets introduced by the analog buffer stage and the analog modulator. The first-order high pass filter response characteristics are detailed in the Digital Filter specifications table. The filter response scales linearly with sample rate.
DIF	I	12	Digital Interface Format (Input) - The required relationship between the Left/Right clock, serial clock and serial data is defined by the Digital Interface Format selection. Refer to Figures 8 and 9.
M0	I	13,	Mode Selection (Input) - (FIXED LOW)
M1	I	14	
TST	I	15	Test Pin (Input) - This pin needs to be connected to GND.
AINL+	I	16,	Differential Left Channel Analog Input (Input) - Signals are presented differentially to the delta-sigma modulators via the AINL+/- pins. The full scale differential analog input level is specified in the Analog Characteristics Specification table.
AINL-	I	17	
VA	I	19	Analog Power (Input) - Positive power supply for the analog section. Refer to the Recommended Operating Conditions for appropriate voltages.
AINR+	I	20,	Differential Right Channel Analog Input (Input) -Signals are presented differentially to the delta-sigma modulators via the AINR+/- pins. The full scale differential analog input level is specified in the Analog Characteristics Specification table.
AINR-	I	21	
VCOM	O	22	Common Mode Voltage (Output) - Nominally 2.5 volts; can be used to bias the analog input circuitry to the common mode voltage of the CS5361. VCOM is not buffered and the maximum current is 10 uA.
REF_GND	I	23	Reference Ground (Input) - Ground reference for the internal sampling circuits and must be connected to analog ground.
FILT+	O	24	Positive Voltage Reference (Output) - Positive reference voltage for the internal sampling circuits. Requires the capacitive decoupling to GND as shown in the Typical Connection Diagram.

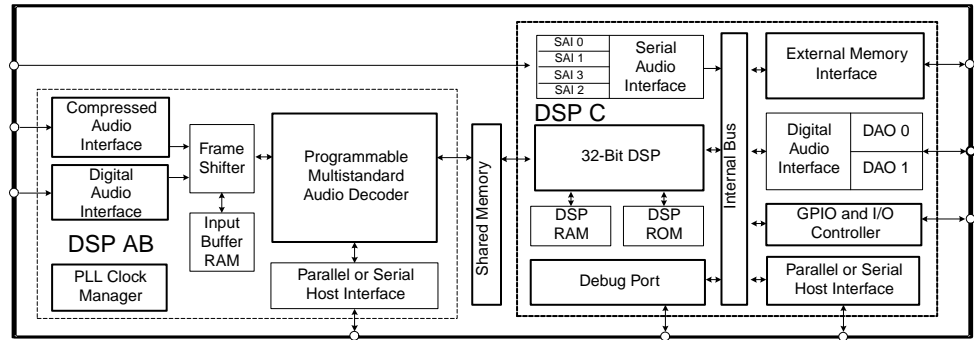

Pin No.	I/O	Function	Description
1	I/O	UHS0, GPIO18	Mode Select Bit 0, General Purpose I/O
2	I/O	UHS1, GPIO19	Mode Select Bit 1, General Purpose I/O
3		INTREQ	Control Port Interrupt Request
4	I	FA1, FSCDIN	Host Address Bit One or SPI Serial Control Data Input
5	I/O	GPIO20	General Purpose I/O
6	I	FA0, FSCCLK	Host Parallel Address Bit Zero or Serial Control Port Clock
7	I/O	FHS2, FSCDIO, FSCDOUT	Mode Select Bit 2 or Serial Control Port Data Input and Output, Parallel Port Type Select
8	I/O	GPIO21	General Purpose I/O
9		FDAT7	DSP AB Bidirectional Data Bus
10		VDD6	2.5V Supply Voltage
11		VSS6	2.5V Ground
12		FHS0, FWR, FDS	Mode Select Bit 0 or Host Write Strobe or Host Data Strobe
13	O	FHS1, FRD, FR/W	Mode Select Bit 1 or Host Parallel Output Enable or Host Parallel R/W
14		FDAT6	DSP AB Bidirectional Data Bus
15	I	FCS	Host Parallel Chip Select, Host Serial SPI Chip Select
16	O	FINREQ	Control Port Interrupt Request
17		FDBCK	Reserved
18		FDAT5	DSP AB Bidirectional Data Bus
19		FDAT4	DSP AB Bidirectional Data Bus
20		VDD7	2.5V Supply Voltage
21		VSS7	2.5V Ground
22		FDAT3	DSP AB Bidirectional Data Bus
23		FDBDA	Reserved
24		FDAT2	DSP AB Bidirectional Data Bus
25		DBDA	Debug Data
26		DBCK	Debug Clock
27		FDAT1	DSP AB Bidirectional Data Bus
28		TEST	Reserved
29		FDAT0	DSP AB Bidirectional Data Bus
30	I/O	NV_WE, GPIO16	SRAM Write Enable, General Purpose I/O
31	I/O	NV_OE, GPIO15	SRAM Output Enable, General Purpose I/O
32	I/O	NV_CS, GPIO14	SRAM Chip Select, General Purpose I/O
33		SD_WE	SDRAM Write Enable
34		SD_DATA0, EXT0	SDRAM Data Bus, SRAM External Data Bus
35		SD_DATA1, EXT1	SDRAM Data Bus, SRAM External Data Bus
36		SD_DATA2, EXT2	SDRAM Data Bus, SRAM External Data Bus
37		SD_DATA3, EXT3	SDRAM Data Bus, SRAM External Data Bus
38		SD_DATA4, EXT4	SDRAM Data Bus, SRAM External Data Bus
39		SD_DQM0	SDRAM Data Mask 2
40		SD_DATA5, EXT5	SDRAM Data Bus, SRAM External Data Bus
41		VSSSD4	3.3V SDRAM/SRAM/EPROM Interface Ground
42		VDDSD4	3.3V SDRAM/SRAM/EPROM Interface Supply
43		SD_DATA6, EXT6	SDRAM Data Bus, SRAM External Data Bus
44		SD_DATA7, EXT7	SDRAM Data Bus, SRAM External Data Bus
45		SD_DQM1	SDRAM Data Mask 1
46		SD_DATA15, EXTA18	SDRAM Data Bus, SRAM External Address Bus
47		SD_DATA14, EXTA17	SDRAM Data Bus, SRAM External Address Bus
48		NC5	No Connect
49		SD_DATA13, EXTA16	SDRAM Data Bus, SRAM External Address Bus
50		VSSSD3	3.3V SDRAM/SRAM/EPROM Interface Ground
51		VDDSD3	3.3V SDRAM/SRAM/EPROM Interface Supply
52		SD_DATA12, EXTA15	SDRAM Data Bus, SRAM External Address Bus

53		SD_DATA11, EXTA14	SDRAM Data Bus, SRAM External Address Bus
54		SD_DATA10, EXTA13	SDRAM Data Bus, SRAM External Address Bus
55		SD_DATA9, EXTA12	SDRAM Data Bus, SRAM External Address Bus
56		SD_DATA8, EXTA11	SDRAM Data Bus, SRAM External Address Bus
57		VSSSD2	3.3V SDRAM/SRAM/EPROM Interface Ground
58		VDDSD2	3.3V SDRAM/SRAM/EPROM Interface Supply
59	O	SD_CLK_OUT	SDRAM Clock Output
60		SD_ADDR9, EXTA9	SDRAM Address Bus, SRAM External Address Bus
61	I	SD_CLK_IN	SDRAM Re-timing Clock Input
62		SD_ADDR8, EXTA8	SDRAM Address Bus, SRAM External Address Bus
63		SD_ADDR7, EXTA7	SDRAM Address Bus, SRAM External Address Bus
64		SD_CLK_EN	SDRAM Clock Enable
65		SD_ADDR6, EXTA6	SDRAM Address Bus, SRAM External Address Bus
66		SD_ADDR5, EXTA5	SDRAM Address Bus, SRAM External Address Bus
67		SD_ADDR4, EXTA4	SDRAM Address Bus, SRAM External Address Bus
68		SD_CS	SDRAM Chip Select
69		VSSSD1	3.3V SDRAM/SRAM/EPROM Interface Ground
70		VDDSD1	3.3V SDRAM/SRAM/EPROM Interface Supply
71		SD_BA, EXTA19	SDRAM Bank Address Select, SRAM External Address Bus
72		SD_ADDR10, EXTA10	SDRAM Address Bus, SRAM External Address Bus
73		SD_ADDR0, EXTA0	SDRAM Address Bus, SRAM External Address Bus
74		SD_ADDR1, EXTA1	SDRAM Address Bus, SRAM External Address Bus
75		SD_ADDR2, EXTA2	SDRAM Address Bus, SRAM External Address Bus
76		SD_ADDR3, EXTA3	SDRAM Address Bus, SRAM External Address Bus
77		SD_RAS	SDRAM Row Address Strobe
78		SD_CAS	SDRAM Column Address Strobe
79	I/O	SDATAN3, GPIO27	PCM Audio Input Data, General Purpose I/O
80	I/O	SDATAN2, GPIO26	PCM Audio Input Data, General Purpose I/O
81	I/O	SDATAN1, GPIO25	PCM Audio Input Data, General Purpose I/O
82	I/O	SDATAN0, GPIO24	PCM Audio Input Data, General Purpose I/O
83		NC4	No Connect
84		NC3	No Connect
85	I/O	LRCLKN, GPIO23	PCM Audio Input Sample Rate Clock, General Purpose I/O
86	I/O	SCLKN, GPIO22	PCM Audio Input Bit Clock, General Purpose I/O
87	O	LRCLK1	Audio Output Sample Rate Clock
88		NC2	No Connect
89		NC1	No Connect
90		VDD1	2.5V Supply Voltage
91		VSS1	2.5V Ground
92	I/O	AUDATA7, XMT958B, GPIO31	Digital Audio Output 7, S/PDIF Transmitter, General Purpose I/O
93	I/O	AUDATA6, GPIO30	Digital Audio Output 6, General Purpose I/O
94	I/O	AUDATA5, GPIO29	Digital Audio Output 5, General Purpose I/O
95	I/O	HDATA7, GPIO7	DSP C Bidirectional Data Bus, General Purpose I/O
96	I/O	HDATA6, GPIO6	DSP C Bidirectional Data Bus, General Purpose I/O
97	I/O	HDATA5, GPIO5	DSP C Bidirectional Data Bus, General Purpose I/O
98	O	SCLK1	Audio Output Bit Clock

Q600 : CS494001-CQ

99	MCLK	Audio Master Clock	
100	VDD2	2.5V Supply Voltage	
101	VSS2	2.5V Ground	
102	I/O	AUDATA4, GPIO28	Digital Audio Output 4, General Purpose I/O
103	I/O	HDATA4, GPIO4	DSP C Bidirectional Data Bus, General Purpose I/O
104	O	SCLK0	Audio Output Bit Clock
105	I/O	HDATA3, GPIO3	DSP C Bidirectional Data Bus, General Purpose I/O
106	O	AUDATA3, XMT958A	Digital Audio Output 3, S/PDIF Transmitter
107	O	AUDATA2	Digital Audio Output 2
108	O	LRCLK0	Audio Output Sample Rate Clock
109	O	AUDATA1	Digital Audio Output 1
110	O	AUDATA0	Digital Audio Output 0
111	I	CMPCCLK, FSCLKN2	PCM Audio Input Bit Clock
112	I/O	HDATA2, GPIO2	DSP C Bidirectional Data Bus, General Purpose I/O
113		VSS3	2.5V Ground
114		VDD3	2.5V Supply Voltage
115	I/O	HDATA1, GPIO1	DSP C Bidirectional Data Bus, General Purpose I/O
116	I/O	HDATA0, GPIO0	DSP C Bidirectional Data Bus, General Purpose I/O
117	O	CMPREQ, FLRCLKN2	Frame Clock Data Request Out
118	I	CMPCDAT, FSDATAN2	PCM Audio Data Input Number Two
119	I	FLRCLKN1	PCM Audio Input Sample Rate Clock
120	I/O	WR, DS, GPIO10	Host Write Strobe, Host Data Strobe, General Purpose I/O
121	I/O	RD, R/W, GPIO11	Host Parallel Output Enable, Host Parallel R/W, General Purpose I/O
122		PLLVSS	PLL Ground Voltage
123		FILT2	Phase Locked Loop Filter
124		FILT1	Phase-Locked Loop Filter
125		PLLVD	PLL Supply Voltage
126	O	CLKOUT, XTALO	Crystal Oscillator Output
127	I	CLKIN, XTALI	External Clock Input/Crystal Oscillator Input
128		CLKSEL	DSP Clock Select
129	I/O	CS, GPIO9	Host Parallel Chip Select, General Purpose I/O
130	I/O	A0, GPIO13	Host Parallel Address Bit 0, General Purpose I/O
131	I	FSDATAN1	PCM Audio Data Input One
132		VDD4	2.5V Supply Voltage
133		VSS4	2.5V Ground
134	I	FSCLKN1, STCCLK2	PCM Audio Input Bit Clock
135		SCS	Host Serial SPI Chip Select
136	I	SCDIN	SPI Serial Control Data Input
137		VSS5	2.5V Ground
138		VDD5	2.5V Supply Voltage
139	I/O	A1, GPIO12	Host Address Bit 1, General Purpose I/O
140	I/O	SCDOUT, SCDIO	Serial Control Port Data Input and Output
141	I/O	HINBSY, GPIO8	Input Host Message Status, General Purpose I/O
142		SCCLK	Serial Control Port Clock
143	I/O	UHS2, CS_OUT, GPIO17	Mode Select Bit 2, External Serial Memory Chip Select, General Purpose I/O
144	I	RESET	Master Reset Input

Q901 : LC72722

Pin Functions

Pin No.	Pin name	I/O	Function	
1	VREF	Output	Reference voltage output (Vdda/2)	
2	MPXIN	Input	Baseband (multiplexed) signal input	
5	FLOUT	Output	Subcarrier output (filter output)	
6	CIN	Input	Subcarrier input (comparator input)	
3	Vdda	—	Analog system power supply (+5 V)	
4	Vssa	—	Analog system ground	
12	XOUT	Output	Crystal oscillator output (4.332/8.664 MHz)	
13	XIN	Input	Crystal oscillator input (external reference signal input)	
7	T1	Input	Test input (This pin must always be connected to ground.)	
8	T2	Input	Test input (standby control) 0: Normal operation, 1: Standby state (crystal oscillator stopped)	
9	T3 (RDCL)	I/O*	Test I/O (RDS clock output)	
10	T4 (RDDA)	I/O*	Test I/O (RDS data output)	
11	T5 (RSFT)	I/O*	Test I/O (soft-decision control data output)	
16	T6 (ERROR/57K/TP/BE1)	I/O*	Test I/O (error status output, regenerated carrier output, TP output, error block count output)	
17	T7 (CORREC/ARI-ID/TA/BE0)	I/O*	Test I/O (Error correction status output, SK detection output, TA output, error block count output)	
18	SYNC	I/O*	Block synchronization detection output	
19	RDS-ID	Output	RDS detection output	
20	DO	Output	Data output	
21	CL	Input	Clock input Serial data interface (CCB)	
22	DI	Input		Data input
23	CE	Input		Chip enable
24	SYR	Input	Synchronization and RAM address reset (active high)	
14	Vddd	—	Digital system power supply (+5 V)	
15	Vssd	—	Digital system ground	

Note: * Normally function as an output pin. Used as an I/O pin in test mode, which is not available to user applications.

Q901 : LC72722

Pin Assignment

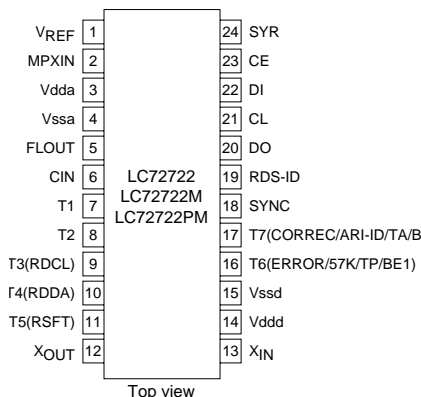

Block Diagram

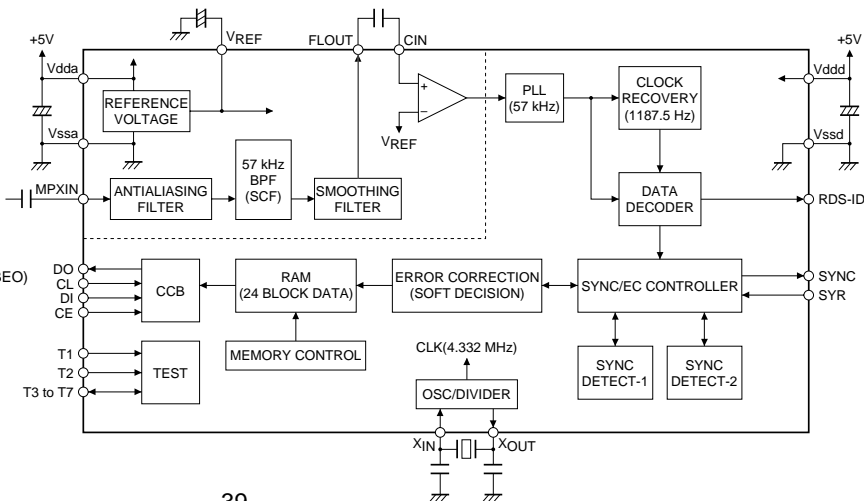

QR01 : LC89057W VF4-E

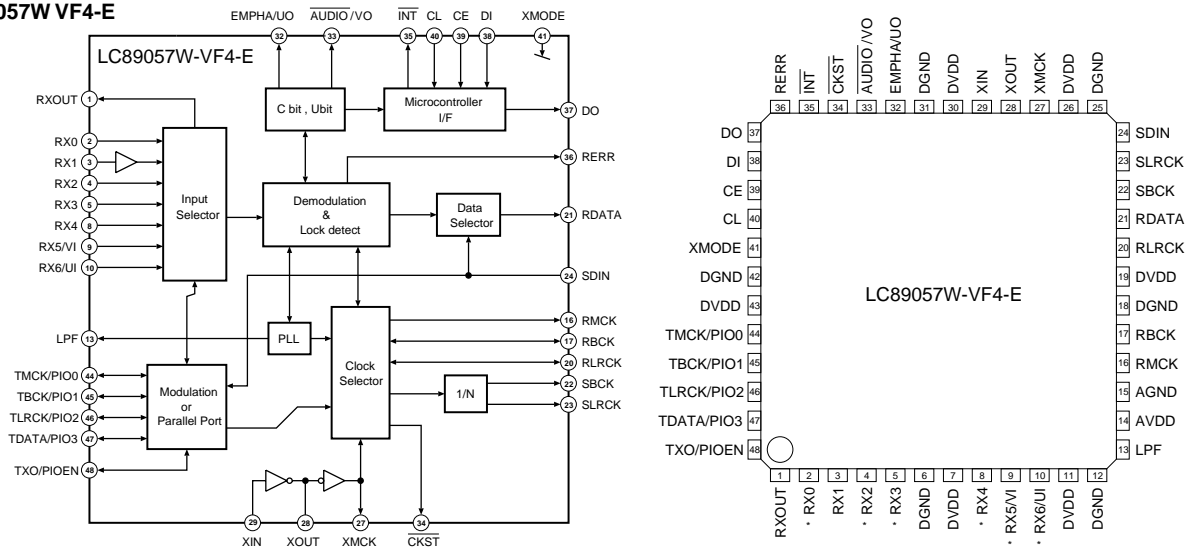

LC89057W

No.	Port name	I/O	Description
1	RXOUT	O	Data Output
2	RX0	I	Digital data Input (TTL)
3	RX1	I	Digital data Input (Coaxial)
4	RX2	I	Digital data Input (TTL)
5	RX3	I	Digital data Input (TTL)
6	DGND		Digital GND
7	DVDD		Digital VDD
8	RX4	I	Digital data Input (TTL)
9	RX5/VI	I	Digital data Input (TTL)
10	RX6/UI	I	Digital data Input (TTL)
11	DVDD		Digital GND for PLL
12	DGND		Digital VDD for PLL
13	LPF	O	Loop filter for PLL
14	AVDD		Analog VDD for PLL
15	AGND		Analog GND for PLL
16	RMCK	O	System clock Output for R (256fs, 512fs, XIN, VCO)
17	RBCK	O/I	Bit clock Output for R (64fs)
18	DGND		Digital GND
19	DVDD		Digital VDD
20	RLRCK	O/I	LR clock Input/Output for R
21	RDATA	O	Serial Audio data Input
22	SBCK	O	Bit clock Output for S (32fs, 64fs, 128fs)
23	SLRCK	O	LR clock Output for S (fs/2, fs, 2fs)
24	SDIN	I	Serial Audio data Input
25	DGND		Digital GND
26	DVDD		Digital VDD
27	XMCK	O	Oscillation amplifier
28	XOUT	O	XOUT
29	XIN	I	XIN or External clock Input (24.576MHz or 12.288MHz)
30	DVDD		Digital VDD
31	DGND		Digital GND
32	EMPHA/VO	I/O	Emphasis Information / U data Output / Set for chip address
33	AUDIO/VO	I/O	Detected non-PCM / V flag Output / Set for chip address
34	CKST	I/O	Clock timing Output / Switch to master or slave for demodulation
35	INT	I/O	Interrupt Output / Switch to Modulation or general-purpose I/O
36	RERR	O	Error Output (PLL lock, data error)
37	DO	O	IF, Read out data Output
38	DI	I	IF, Write data Input
39	CE	I	IF, Chip enable Input
40	CL	I	IF, Clock Input
41	XMODE	I	System reset Input
42	DGND		Digital GND
43	DVDD		Digital VDD
44	TMCK/PIO0	I/O	256fs system-clock Input for modulation / General-purpose I/O input/output
45	TBCK/PIO1	I/O	64fs bit-clock Input for modulation / General-purpose I/O input/output
46	TLRCK/PIO2	I/O	Fs clock Input for modulation / General-purpose I/O input/output
47	TDATA/PIO3	I/O	Serial audio data for modulation / General-purpose I/O input/output
48	TXO/PIOEN	O/I	Modulation data Output / General-purpose I/O enable input

QE11/QE12 : TC9499N

OTC9499N/F

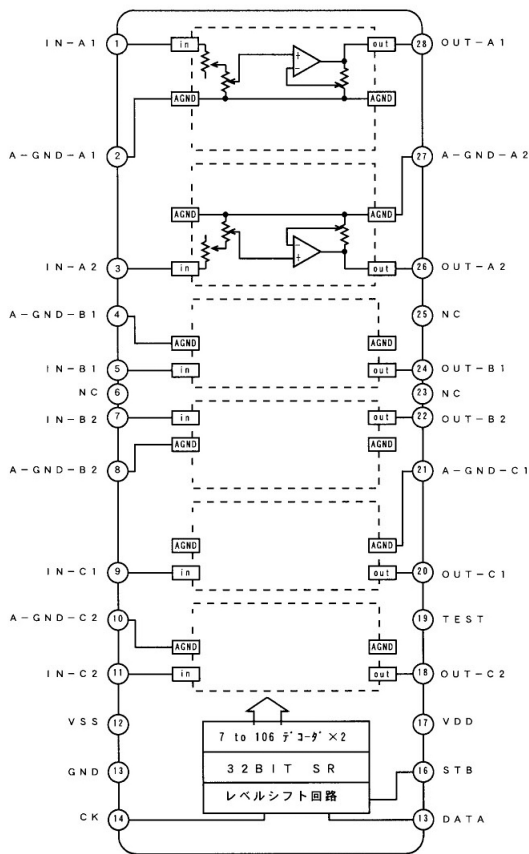

QU03 : HIN202ECB

TOP VIEW

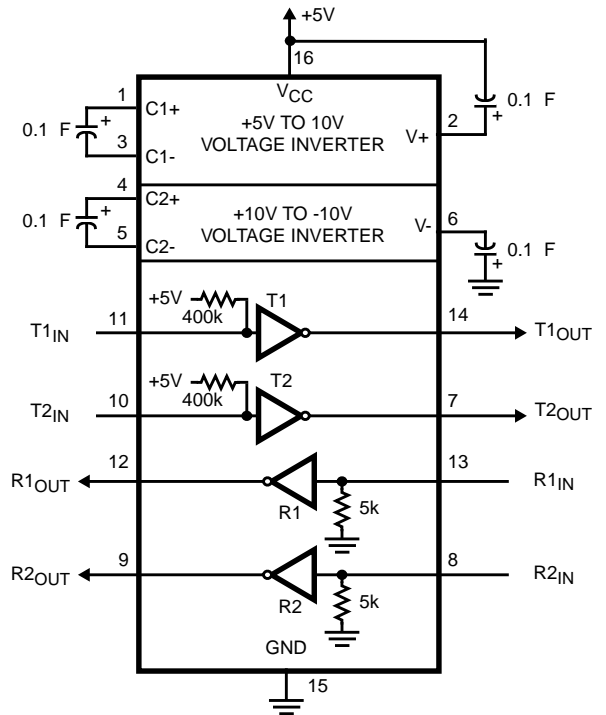
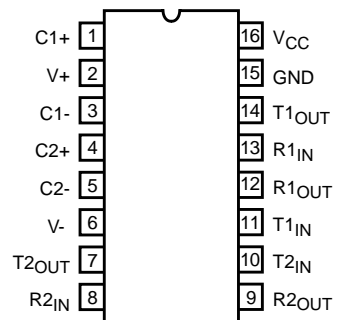

QU03 : HIN202ECB

Pin Descriptions

PIN	FUNCTION
V _{CC}	Power Supply Input 5V 10%, (5V 5% HIN207E).
V+	Internally generated positive supply (+10V nominal).
V-	Internally generated negative supply (-10V nominal).
GND	Ground Lead. Connect to 0V.
C1+	External capacitor (+ terminal) is connected to this lead.
C1-	External capacitor (- terminal) is connected to this lead.
C2+	External capacitor (+ terminal) is connected to this lead.
C2-	External capacitor (- terminal) is connected to this lead.
T _{IN}	Transmitter Inputs. These leads accept TTL/CMOS levels. An internal 400kΩ pull-up resistor to V _{CC} is connected to each lead.
T _{OUT}	Transmitter Outputs. These are RS-232 levels (nominally ±10V).
R _{IN}	Receiver Inputs. These inputs accept RS-232 input levels. An internal 5kΩ pull-down resistor to GND is connected to each input.
R _{OUT}	Receiver Outputs. These are TTL/CMOS levels.
\overline{EN}	Enable Input. This is an active low input which enables the receiver outputs. With $\overline{EN} = 5V$, the outputs are placed in a high impedance state.
SD, \overline{SD}	Shutdown Input. With SD = 5V (HIN213E $\overline{SD} = 0V$), the charge pump is disabled, the receiver outputs are in a high impedance state (except R4 and R5 of HIN241E) and the transmitters are shut off.
NC	No Connect. No connections are made to these leads.

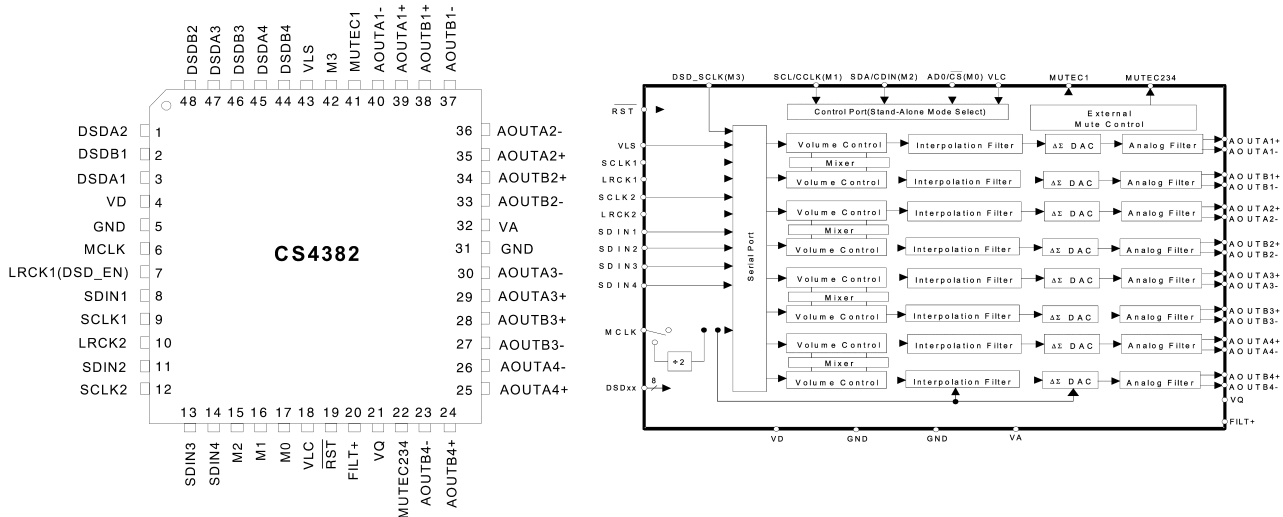

Pin Name I/O #

VD	4	Digital Power (Input) - Positive power supply for the digital section. Refer to the Recommended Operating Conditions for appropriate voltages.
GND	5 31	Ground (Input) - Ground reference. Should be connected to analog ground
MCLK	6	Master Clock (Input) - Clock source for the delta-sigma modulator and digital filters. Table 5 illustrates several standard audio sample rates and the required master clock frequency.
LRCK1	7	Left Right Clock (Input) - Determines which channel, Left or Right, is currently active on the serial audio data line. The frequency of the left/right clock must be at the audio sample rate, Fs.
LRCK2	10	
SDIN1	8	Serial Audio Data Input (Input) - Input for two's complement serial audio data.
SDIN2	11	
SDIN3	13	
SDIN4	14	
SCLK1	9	Serial Clock (Input) - Serial clock for the serial audio interface.
SCLK2	12	
VLC	18	Control Port Power (Input) - Determines the required signal level for the control port. Refer to the Recommended Operating Conditions for appropriate voltages.
RST	19	Reset (Input) - The device enters a low power mode and all internal registers are reset to their default settings when low.
FILT+	20	Positive Voltage Reference (Output) - Positive reference voltage for the internal sampling circuits. Requires the capacitive decoupling to analog ground, as shown in the Typical Connection Diagram.
VQ	21	Quiescent Voltage (Output) - Filter connection for internal quiescent voltage. VQ must be capacitively coupled to analog ground, as shown in the Typical Connection Diagram. The nominal voltage level is specified in the Analog Characteristics and Specifications section. VQ presents an appreciable source impedance and any current drawn from this pin will alter device performance. However, VQ can be used to bias the analog circuitry assuming there is no AC signal component and the DC current is less than the maximum specified in the Analog Characteristics and Specifications section.

Pin Name	I/O	#	
MUTEC1	O	41	Mute Control (Output) - The Mute Control pins go high during power-up initialization, reset, muting, power-down or if the master clock to left/right clock frequency ratio is incorrect. These pins are intended to be used as a control for external mute circuits to prevent the clicks and pops that can occur in any single supply system. The use of external mute circuits are not mandatory but may be desired for designs requiring the absolute minimum in extraneous clicks and pops.
MUTEC234	O	22	
AOUTA1 +,-	O	39, 40	Differential Analog Output (Output) - The full scale differential analog output level is specified in the Analog Characteristics specification table.
AOUTB1 +,-	O	38, 37	
AOUTA2 +,-	O	35, 36	
AOUTB2 +,-	O	34, 33	
AOUTA3 +,-	O	29, 30	
AOUTB3 +,-	O	28, 27	
AOUTA4 +,-	O	25, 26	
AOUTB4 +,-	O	24, 23	
VA	I	32	Analog Power (Input) - Positive power supply for the analog section. Refer to the Recommended Operating Conditions for appropriate voltages.
VLS	I	43	Serial Audio Interface Power (Input) - Determines the required signal level for the serial audio interface. Refer to the Recommended Operating Conditions for appropriate voltages.

Stand-Alone Definitions

M0	17	Mode Selection (Input) - Determines the operational mode of the device as detailed in Tables 6 and 7.
M1	16	FIXED GND
M2	15	FIXED GND
M3	42	

DSD Definitions

DSDA1	3	FIXED GND
DSDB1	2	FIXED GND
DSDA2	1	FIXED GND
DSDB2	48	FIXED GND
DSDA3	47	FIXED GND
DSDB3	46	FIXED GND
DSDA4	45	FIXED GND
DSDB4	44	FIXED GND

QC01 : NJU3430FG1

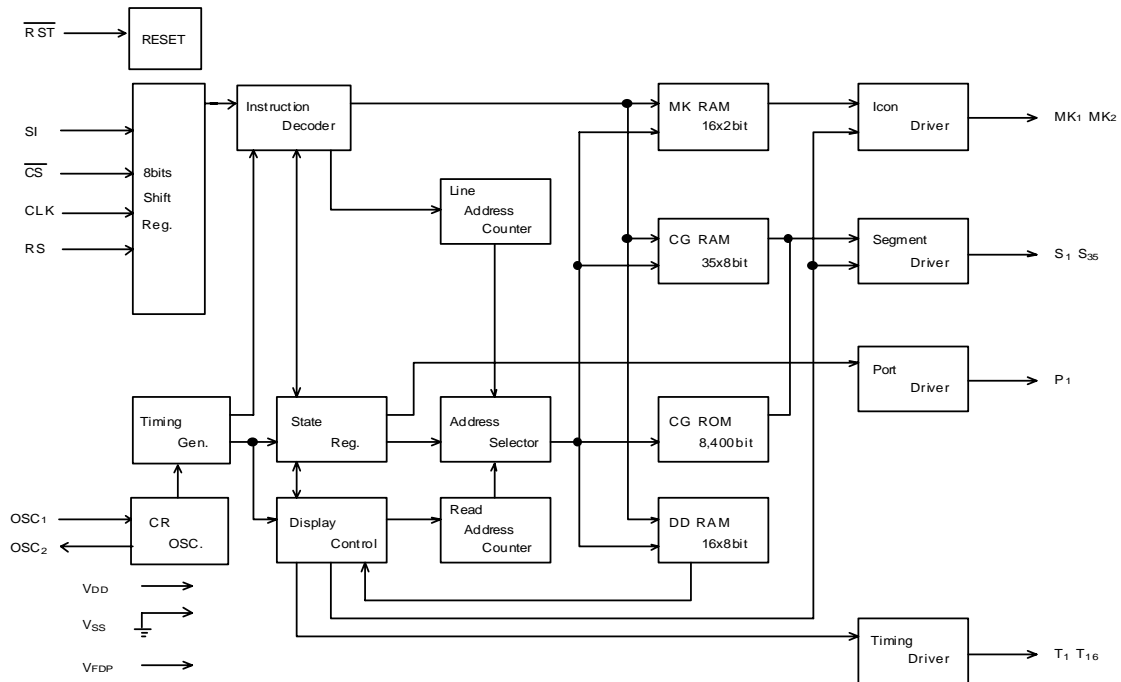

No.	SYMBOL	I/O	F U N C T I O N
57	VDD	-	Power Source : VDD=+3.0 to 5.5V
49	VSS	-	GND : VSS=0V
48	VFDP	-	VFD Driving Power Source VDD-20V to VDD-45V
50	OSC1	I	CR Oscillation Terminal External R and C connect to these terminals. (Target fOSC=360kHz)
51	OSC2	O	
54	CLK	I	Serial Clock Input Terminal The serial data input synchronizing the rise edge of this terminal.
53	CS	I	Chip Select Terminal When the CS terminal is "H" the serial data input is not available.
55	SI	I	Serial Data Input Terminal The data input is MSB first.
56	RS	I	Register Selection Signal Input Terminal RS="0" : Instruction Register RS="1" : Data Register
52	RST	I	Reset Terminal RST="L" : Reset -Each Address : (00)H -Each RAM Data : Unfixed -Display Digits : 16-digit -Contrast Control : 8/16 Duty -All Display Off -All Outputs are "L"
61 to 64, 1 to 31	S1 to S35	O	Segment Output Terminals (Internal Pull-down Resistance)
32 to 47	T1 to T16	O	Timing Output Terminals (Internal Pull-down Resistance)
60 59	MK1 MK2	O	Icon Output Terminals (Internal Pull-down Resistance)
58	P1	O	Output Port Terminal This terminal is suitable for LED.

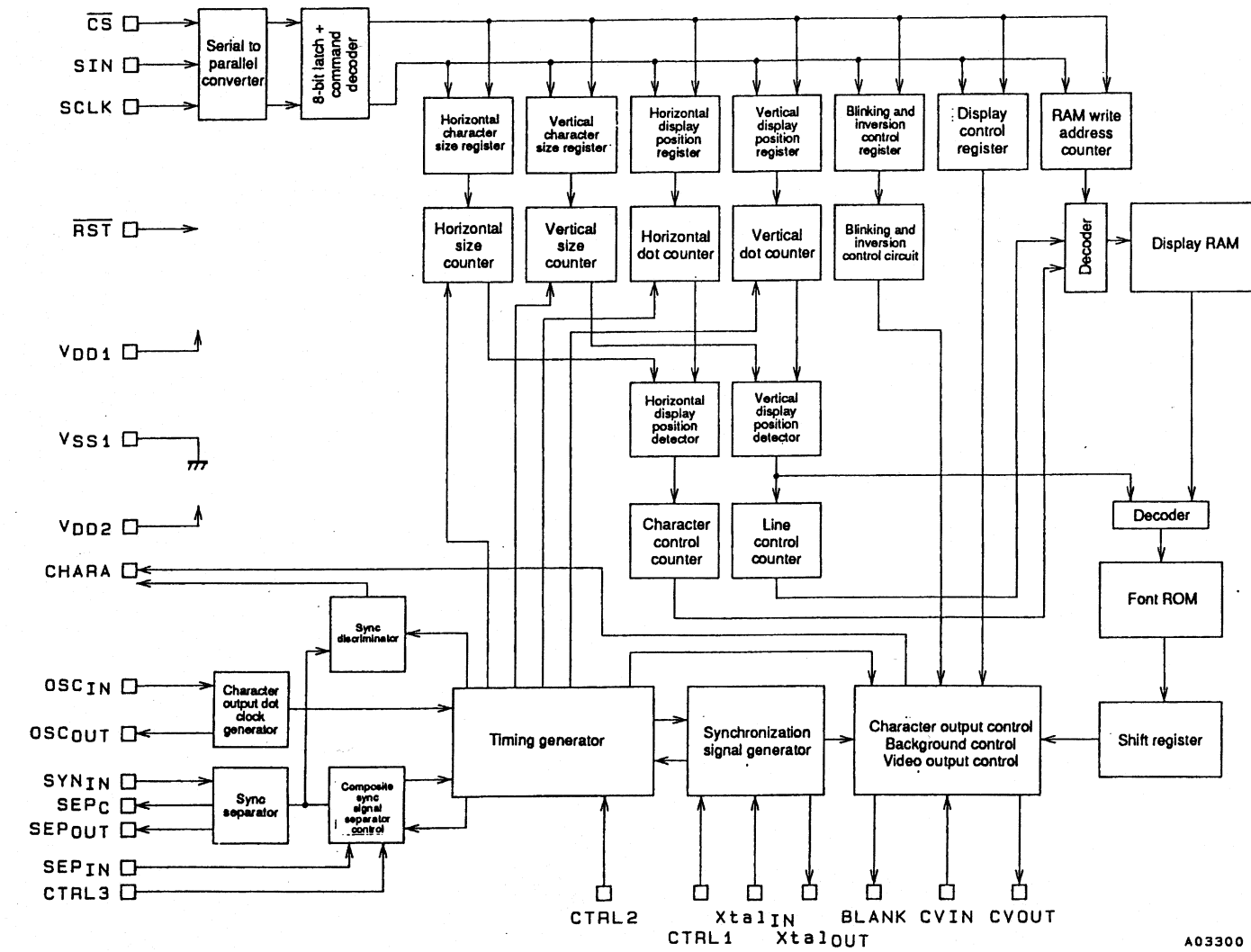

A03300

Pin Functions

Pin No.	Symbol	Function	Description
1	V _{SS1}	Ground	Ground connection (digital system ground)
2	Xtal _{IN}	Crystal oscillator connection	Used to connect the crystal oscillator and capacitor used to generate the internal synchronization signal, or to input an external clock (2fsc or 4fsc).
3	Xtal _{OUT}	Crystal oscillator connection	Used to connect the crystal oscillator and capacitor used to generate the internal synchronization signal, or to input an external clock (2fsc or 4fsc).
4	CTRL1	Crystal oscillator input switching	Switches between external clock input mode and crystal oscillator mode. Low = crystal oscillator mode, high = external clock mode
5	BLANK	Blanking output	Outputs the blank signal (the OR of the character and border signals). (Outputs a composite sync signal when MOD0 is high.) Outputs the crystal oscillator clock during reset (when the RST pin is low), but can be set up to not output this signal by microprocessor command.
6	OSC _{IN}	LC oscillator connection	Connections for the coil and capacitor that form the oscillator that generates the character output dot clock.
7	OSC _{OUT}	LC oscillator connection	Connections for the coil and capacitor that form the oscillator that generates the character output dot clock.
8	CHARA	Character output	Outputs the character signal. (Functions as the external synchronization signal discrimination signal output pin when MOD0 is high, and outputs the state of the judgment as to whether the external synchronization signal is present or not. Outputs a high level when the synchronization signal is present.) Outputs the dot clock (LC oscillator) during reset, but can be set up to not output this signal by microprocessor command.
9	CS	Enable input	Serial data input enable input. Serial data input is enabled when low. A pull-up resistor is built in (hysteresis input).
10	SCLK	Clock input	Serial data input clock input. A pull-up resistor is built in (hysteresis input).
11	SIN	Data input	Serial data input. A pull-up resistor is built in (hysteresis input).
12	V _{DD2}	Power supply	Composite video signal level adjustment power supply pin (analog system power supply).
13	CV _{OUT}	Video signal output	Composite video signal output
14	NC		Must be either connected to ground or left open.
15	CV _{IN}	Video signal input	Composite video signal input
16	V _{DD1}	Power supply	Power supply (+5 V: digital system power supply)
17	SYN _{IN}	Sync separator circuit input	Video signal input for the built-in sync separator circuit (Used for either horizontal synchronization signal or composite sync signal input when the built-in sync separator circuit is not used.)
18	SEP _C	Sync separator circuit bias voltage	Built-in sync separator circuit bias voltage monitor pin
19	SEP _{OUT}	Composite sync signal output	Built-in sync separator circuit composite sync signal output. (When MOD1 is high, outputs a high level during internal synchronization and a low level during external synchronization.) (Outputs the SYN _{IN} input signal when the internal sync separator circuit is not used.)
20	SEP _{IN}	Vertical synchronization signal input	Inputs a vertical synchronization signal created by integrating the SEP _{OUT} pin output signal. An integrator must be attached at the SEP _{OUT} pin. This pin must be tied to V _{DD1} if unused.
21	CTRL2	NTSC/PAL-M switching input	The setting indicated by this pin takes priority in switching between the NTSC, PAL, PAL-M and PAL-N formats. A low level selects NTSC after a reset. The microprocessor command NTSC, PAL, PAL-M, or PAL-N setting is valid. High = PAL-M format.
22	CTRL3	SEP _{IN} input control	Controls whether or not the VSYNC signal is input to the SEP _{IN} input. Low = VSYNC input, high = VSYNC not input.
23	RST	Reset input	System reset input. A pull-up resistor is built in (hysteresis input).
24	V _{DD1}	Power supply (+5 V)	Power supply (+5 V: digital system power supply)

QN01: TA7317P

Equivalent Circuit Diagram

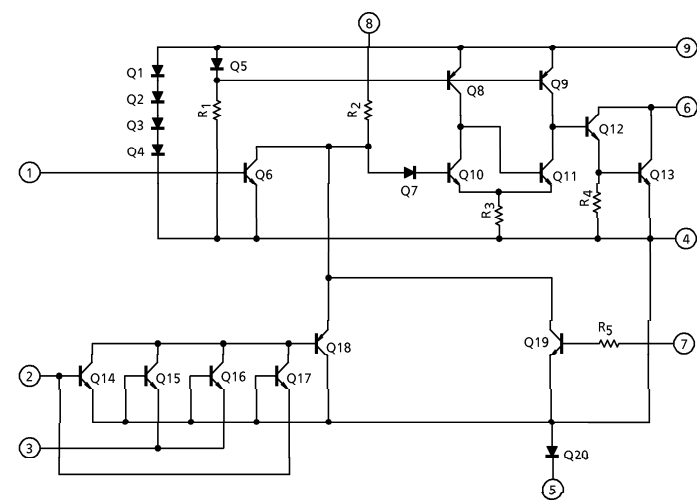

8. EXPLODED VIEW AND PARTS LIST

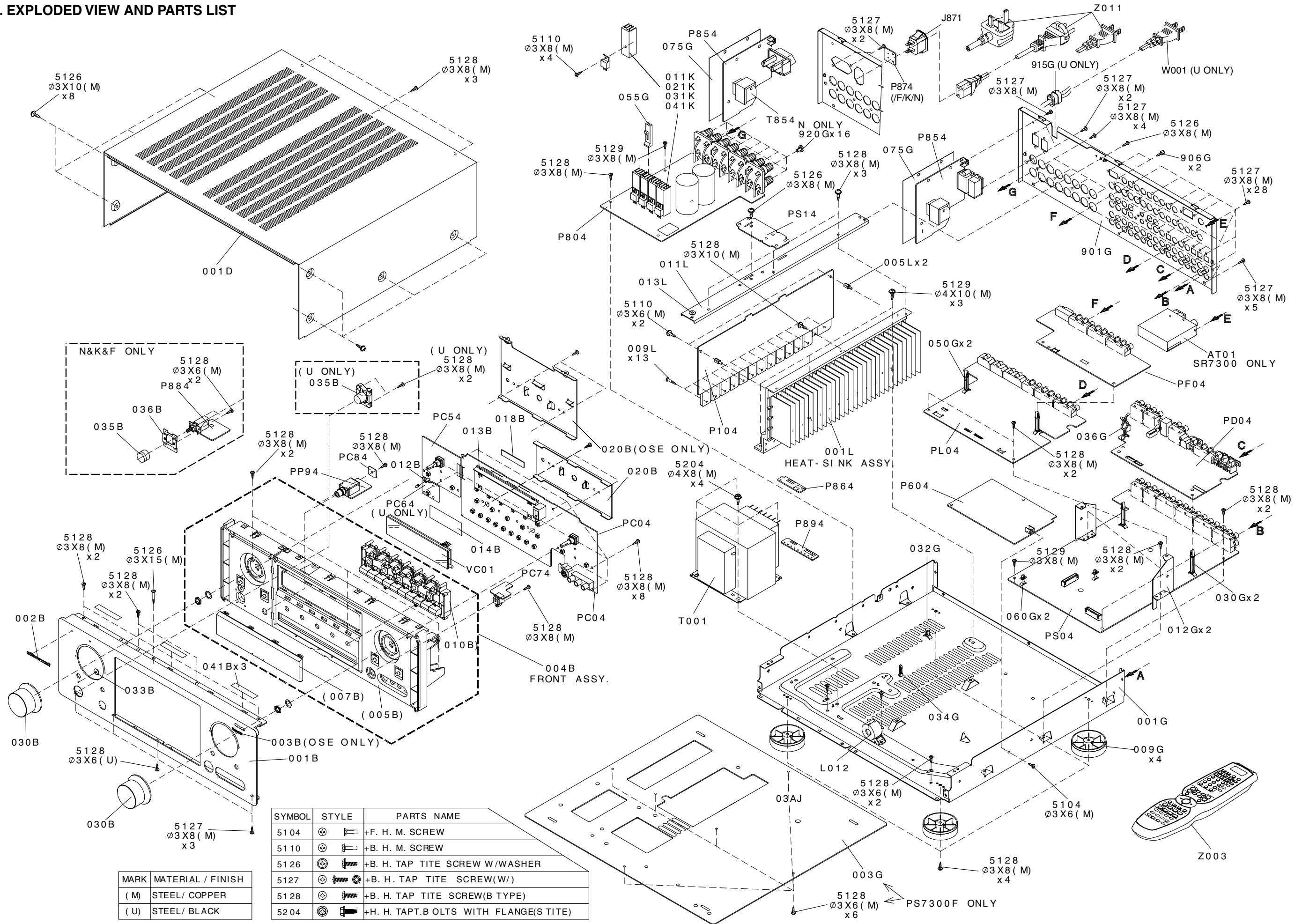

SR7300

POS. NO	VERS. COLOR	PART NO. (FOR EUR)	DESCRIPTION	PART NO. (MJI)
001B	/N1B	03AJ248010	FRONT AL PANEL (BLACK)	03AJ248010
001B	/U1B		FRONT AL PANEL STANDBY (BLACK)	03AJ248020
001B	/K1G	03AJ248110	FRONT AL PANEL (GOLD)	03AJ248110
001B	/N1G		FRONT AL PANEL STANDBY (GOLD)	03AJ248120
002B		185J251010	MARANTZ BADGE	185J251010
004B	BLACK	03AJ105500	CHASSIS FRONT MOLD ASSY (BL)	03AJ105500
004B	GOLD	03AJ105510	CHASSIS FRONT MOLD ASSY (GL)	03AJ105510
005B	BLACK	03AJ105020	CHASSIS FRONT MOLD (BLACK)	03AJ105020
005B	GOLD	03AJ105120	CHASSIS FRONT MOLD (GOLD)	03AJ105120
010B	BLACK	03AJ270010	BUTTON FUNCTION (BLACK)	03AJ270010
010B	GOLD	03AJ270110	BUTTON FUNCTION (GOLD)	03AJ270110
030B	BLACK	03AJ154010	KNOB MASTER (BLACK)	03AJ154010
030B	GOLD	03AJ154020	KNOB MASTER (GOLD)	03AJ154020
033B		312J355010	LENS STANDBY	312J355010
035B	/N1B	02AK270040	BUTTON POWER SW (BLACK)	02AK270040
035B	/K1G	02AK270140	BUTTON POWER SW (GOLD)	02AK270140
035B	/U1B		BUTTON POWER SW (BLACK)	320J270040
035B	/U1G		BUTTON POWER SW (GOLD)	320J270240
009G		03AJ057110	LEG	03AJ057110
055G		03AJ101030	SUPPORT FOR PCB AC OUT	03AJ101030
906G		396B010030	SCREW FOR RS-232C+R/P	396B010030
915G	/U		BUSH FOR AC CORD	450H259010
009L		343J010010	SCREW FOR TR&DIODE	343J010010
AT01	/U		TUNER MODULE TFCE1U118A	AV01202280
AT01	/K/N	AV01203030	TUNER MODULE TFCE1E113A	AV01203030
▲ T001	/U		MAINS TRANSF. AC120V 60Hz	TS60515040
▲ T001	/K/N	TS60515050	MAINS TRANSF. AC230/220V	TS60515050
▲ W001	/U		MAINS CORD UL/CSA NON-INTEGRA	YC02000880
W601	nsp		JUMPER LEAD FMN15-FMN JU05(P604)JL05(PL04)	YU15110520
W602	nsp		JUMPER LEAD FMN33-FMN JU06(P604)JA08(PD04)	YU33170520
WC01	nsp		JUMPER LEAD FMN16-FMN JC03(PC04)JU03(P604)	YU16160520
WC02	nsp		JUMPER LEAD FMN13-FMN JU04(P604)J810(P804)	YU13440520
WG04	nsp		JUMPER LEAD FMN19P-FMNJE10(PS04)J972(PD04)	YU19220520
WG05	nsp		JUMPER LEAD 15FE JT01(PD04)TUNER PACK	YU15150500
WL01	nsp		JUMPER LEAD FMN11-FMN JL06(PL04)JF54(PF04)	YU11110520
WP03	nsp		JUMPER LEAD FMN7P-FMN JP03(PC04)JS06(PS04)	YU07160520
			PACKING	
001T	/U		USER GUIDE SR7300 U	03AJ851250
001T	/N	03AJ851310	USER GUIDE SR7300 N	03AJ851310
001T	/K		USER GUIDE SR7300 K	03AJ851350
Z003		ZK03AJ0010	REMOTE CONTROLLER RC7300SR	ZK03AJ0010
▲ Z011	/N	ZC01803080	MAINS CORD 2P 10A 250V CLASS2	ZC01803080
▲ Z011	/K		MAINS CORD CCEE 10A 250V	ZC01803090
			NOT STANDARD SPARE PARTS	
001D	BLACK		LID TOP COVER (BLACK)	03AJ257010
001D	GOLD		LID TOP COVER (GOLD)	03AJ257110
001S	/K/N/U		PACKING CASE SR7300	03AJ801010
002S			CUSHION	03AJ809010

NOTE : "nsp" PART IS LISTED FOR REFERENCE ONLY, MARANTZ WILL NOT SUPPLY THESE PARTS.

SR7300F

POS. NO	VERS. COLOR	PART NO. (FOR EUR)	DESCRIPTION	PART NO. (MJI)
001B	/N1B	03AJ248210	FRONT AL PANEL (BLACK) OSE	03AJ248210
001B	/U1B		FRONT AL PANEL STANDBY (BLACK) OSE	03AJ248220
001B	/K1G	03AJ248310	FRONT AL PANEL (GOLD) OSE	03AJ248310
001B	/N1G		FRONT AL PANEL STANDBY (GOLD) OSE	03AJ248320
002B		185J251010	MARANTZ BADGE	185J251010
003B		255W251010	BADGE OSE	255W251010
004B	BLACK	03AJ105500	CHASSIS FRONT MOLD ASSY (BL)	03AJ105500
004B	GOLD	03AJ105510	CHASSIS FRONT MOLD ASSY (GL)	03AJ105510
005B	BLACK	03AJ105020	CHASSIS FRONT MOLD (BLACK)	03AJ105020
005B	GOLD	03AJ105120	CHASSIS FRONT MOLD (GOLD)	03AJ105120
007B		03AJ158010	WINDOW OSE	03AJ158010
010B	BLACK	03AJ270010	BUTTON FUNCTION (BLACK)	03AJ270010
010B	GOLD	03AJ270110	BUTTON FUNCTION (GOLD)	03AJ270110
030B	BLACK	03AJ154010	KNOB MASTER (BLACK)	03AJ154010
030B	GOLD	03AJ154020	KNOB MASTER (GOLD)	03AJ154020
033B		312J355010	LENS STANDBY	312J355010
035B	/N1B	02AK270040	BUTTON POWER SW (BLACK)	02AK270040
035B	/K1G	02AK270140	BUTTON POWER SW (GOLD)	02AK270140
035B	/U1B		BUTTON POWER SW (BLACK)	320J270040
035B	/U1G		BUTTON POWER SW (GOLD)	320J270240
009G		03AJ057110	LEG	03AJ057110
055G		03AJ101030	SUPPORT FOR PCB AC OUT	03AJ101030
906G		396B010030	SCREW FOR RS-232C+R/P	396B010030
915G	/U		BUSH FOR AC CORD	450H259010
009L		343J010010	SCREW FOR TR&DIODE	343J010010
AT01	/U		TUNER MODULE TFCE1U118A	AV01202280
AT01	/K/N	AV01203030	TUNER MODULE TFCE1E113A	AV01203030
▲ T001	/U		MAINS TRANSF. AC120V 60Hz	TS60515040
▲ T001	/K/N	TS60515050	MAINS TRANSF. AC230/220V	TS60515050
▲ W001	/U		MAINS CORD UL/CSA NON-INTEGRA	YC02000880
W601	nsp		JUMPER LEAD FMN15-FMN JU05(P604)JL05(PL04)	YU15110520
W602	nsp		JUMPER LEAD FMN33-FMN JU06(P604)JA08(PD04)	YU33170520
WC01	nsp		JUMPER LEAD FMN16-FMN JC03(PC04)JU03(P604)	YU16160520
WC02	nsp		JUMPER LEAD FMN13-FMN JU04(P604)J810(P804)	YU13440520
WG04	nsp		JUMPER LEAD FMN19P-FMNJE10(PS04)J972(PD04)	YU19220520
WG05	nsp		JUMPER LEAD 15FE JT01(PD04)TUNER PACK	YU15150500
WL01	nsp		JUMPER LEAD FMN11-FMN JL06(PL04)JF54(PF04)	YU11110520
WP03	nsp		JUMPER LEAD FMN7P-FMN JP03(PC04)JS06(PS04)	YU07160520
			PACKING	
001T	/U		USER GUIDE SR7300 U	03AJ851250
001T	/N	03AJ851310	USER GUIDE SR7300 N	03AJ851310
001T	/K		USER GUIDE SR7300 K	03AJ851350
Z003		ZK03AJ0010	REMOTE CONTROLLER RC7300SR	ZK03AJ0010
▲ Z011	/N	ZC01803080	MAINS CORD 2P 10A 250V CLASS2	ZC01803080
▲ Z011	/K		MAINS CORD CCEE 10A 250V	ZC01803090
			NOT STANDARD SPARE PARTS	
001D	BLACK		LID TOP COVER (BLACK)	03AJ257010
001D	GOLD		LID TOP COVER (GOLD)	03AJ257110
001S	/K/N/U		PACKING CASE SR7300F	03AJ801030
002S			CUSHION	03AJ809010

PS7300

POS. NO	VERS. COLOR	PART NO. (FOR EUR)	DESCRIPTION	PART NO. (MJI)
001B	BLACK		FRONT AL PANEL (BLACK)	03AJ248040
001B	GOLD		FRONT AL PANEL (GOLD)	03AJ248140
002B			MARANTZ BADGE	185J251010
004B	BLACK		CHASSIS FRONT MOUD ASSY(BL)	03AJ105530
004B	GOLD		CHASSIS FRONT MOUD ASSY (GL)	03AJ105540
005B	BLACK		CHASSIS FRONT MOLD (BLACK)	03AJ105020
005B	GOLD		CHASSIS FRONT MOLD (GOLD)	03AJ105120
007B			WINDOW (PS)	03AJ158040
010B	BLACK		BUTTON FUNCTION (BLACK)	03AJ270010
010B	GOLD		BUTTON FUNCTION (GOLD)	03AJ270110
030B	BLACK		KNOB MASTER (BLACK)	03AJ154010
030B	GOLD		KNOB MASTER (GOLD)	03AJ154020
033B			LENS STANDBY	312J355010
035B	BLACK		BUTTON POWER SW (BLACK)	02AK270040
035B	GOLD		BUTTON POWER SW (GOLD)	02AK270140
009G			LEG	03AJ057110
055G			SUPPORT FOR PCB AC OUT	03AJ101030
906G			SCREW FOR RS-232C+R/P	396B010030
009L			SCREW FOR TR&DIODE	343J010010
▲ T001			MAINS TRANSF. AC100V 50/60Hz	TS60515060
W601			JUMPER LEAD FMN15-FMN JU05(P604)JL05(PL04)	YU15110520
W602			JUMPER LEAD FMN33-FMN JU06(P604)JA08(PD04)	YU33170520
WC01			JUMPER LEAD FMN16-FMN JC03(PC04)JU03(P604)	YU16160520
WC02			JUMPER LEAD FMN13-FMN JU04(P604)J810(P804)	YU13440520
WG04			JUMPER LEAD FMN19P-FMNJE10(PS04)J972(PD04)	YU19220520
WL01			JUMPER LEAD FMN11-FMN JL06(PL04)JF54(PF04)	YU11110520
WP03			JUMPER LEAD FMN7P-FMN JP03(PC04)JS06(PS04)	YU07160520
			PACKING	
001T			USER GUIDE SR7300 F	03AJ851110
Z003			REMOTE CONTROLLER RC7300SR	ZK03AJ0010
▲ Z011			MAINS CORD 2P FOR 12A 125V AC	ZC01801050
			NOT STANDARD SPARE PARTS	
001D	BLACK		LID TOP COVER (BLACK)	03AJ257010
001D	GOLD		LID TOP COVER (GOLD)	03AJ257110
001S			PACKING CASE PS7300	03AJ801020
002S			CUSHION 03AJ	809010

NOTE : "nsp" PART IS LISTED FOR REFERENCE ONLY, MARANTZ WILL NOT SUPPLY THESE PARTS.

9. SERVICE PROGRAM

Factory Mode

With the following procedure, the Tracking Point, which is necessary for the adjustment and measurement of the tuner, can be memorized.

1. Turn on the unit, press **DVD, TUNER** and **7.1ch - IN** key simultaneously more than three seconds.
2. "FACTORY MODE" will be displayed on the FLD for two seconds and the following frequencies will be stored in the Preset Memory.

Band	Version	P1	P2	P3	P4
FM AUTO [MHz]	/U /K/ S /N	90.0	98.0	106.0	87.5
	/F	78.0	83.0	88.0	76.0

Band	Scan Step	P5	P6	P7	P8	P9	P10	P11	P12	P13
AM [kHz]	10 kHz (U)	600	1000	1400	520				No	
	9kHz(/F/N/K/S)	603	999	1404	531				Preset	

Microprocessor (CPU), DSP Version and FLD Segment Check Mode

Turn the unit into the Factory Mode (See above) first. Each time **V-OFF** button on the Remote controller is pressed or RC-5 code **161302 (Display)** is entered, information shown on the FLD changes in the following order. Software versions of μ -com and DSP can be seen and FLD segments can be checked.

1. Model Name is displayed. (Ex. : SR7300)
2. Software version of QU01(CPU) is displayed in the following format.

V	0	2	0	9	2	7	0				
LYearJ		LMonthJ		LDateJ		LVer.J					

3. Software Serial Number that is written in the factory is displayed.

M	Z	X	X	X	X	X	X	X	X	X	X	X
---	---	---	---	---	---	---	---	---	---	---	---	---

4. Software Type Number is displayed

S	O	F	T		T	Y	P	E			X	X
(XX is displayed in Hex)												

5. Group Type Number of the code that is written in the DSP's external ROM is displayed.

C	O	D	E		T	Y	P	E	X	X	X	X
---	---	---	---	--	---	---	---	---	---	---	---	---

6. 1G and 2G of the FLD is lighted each other. (Character part of Dot Matrix stays off.)
7. Dot Matrix part of the FLD lights in the checker pattern. (Other part stays off.)
8. Code ID of the code that is written in the DSP's external ROM is displayed.

C	D	X	X		X	X	X	X	X	X	X	X
LCode No.J		LDeviceJ		LCode SigJ		LCode TypeJ		LVersionJ				
		ID		ID		ID						

9. Returns to the step 1 and repeats the sequence.
10. Press **DISPLAY** button to quit this mode.

Note : Step4, 5 is to check if CPU software is capable of DSP code. "Software Type No" is to show what "DSP Code Group" CPU is capable of. And vice versa.

Step 8 is to manage the 16 codes for DSP.

- When the unit is once turned into Factory Mode, the unit keeps this mode until the main power is turned off. (Turning into stand-by mode does not make it quit from Factory Mode.) When the unit quits from Factory Mode, Information in the memory is also cleared and the unit returns to the status when it is out from the factory.

Product Reset

To reset the back up memory of the unit into the default status, follow the procedure below.

1. Turn of the unit and press **SELECT** and **ATT** keys simultaneously more than 1.5 seconds.
2. After "DEFAULT" is displayed on FLD, power is turned off once and turned of again, EEPROM is cleared to the default status, μ -com is reset and the unit returns to the normal status. (Software Serial Number will not be cleared.)

Note : When the unit is shipped from the factory, the procedure above must be done to set the unit to initial status after the tests.

10. UPDATE FIRMWARE

Software for CPU and DSP can be updated.

Have *SR7300CDR update disc.

There are two mode of download, regarding to the target of software as bellow.

Mode 1: Download DSP's software to 4M Flash-ROM.

This mode is to update the software for DSP.

The target devise is 4M Flash-ROM (Q601) on P604.

SR7300 need to be set download condition, by three front keys.

Mode 2: Download CPU's software to internal Flash-ROM.

This mode is to update the software for DSP.

The target devise is internal flash ROM of CPU (QU01) on P604.

The unit needs to be set to writing condition, by pushing internal switch from back-panel.

The following items are required for updating.

RS232C Dsub-9 pin cable (female to female/Straight type)

PC (Windows 98, NT, ME, 2000) with RS-232C port.

Upgrade software to CPU.

Upgrade software to DSP.

Use RS232C Dsub-9 pin cable (female to female/Straight type) to connect PC and the unit.

COM port on PC needs to be set by dialog box for each program. COM port can be set from COM1 to COM5.

Download Firmware for DSP (Mode 1)

1. Put the "DSP upgrade" folder into anywhere on your PC's hard disc.
2. Connect PC and the unit with the RS-232C cable.
3. Turn on the unit.
4. Press **ENTER**, **MUTE** and **CD** buttons simultaneously more than 5 seconds to turn the unit into Loading Mode.
5. "LOADING MODE" will be shown on FLD.
6. Launch "UpgradeDSP.exe" on PC.
7. Set the Baud Rate to 38400 then click **Start communication** button. If the connection is made successfully, a dialog box saying "Success to connect" appears and "CONNECTED" is displayed on FLD.
8. Click **Send the DSP codes** button on the dialog box. Progress status of downloading will be shown on PC and OADING is displayed on FLD.
9. If downloading is completed successfully, "COMPLETED" is displayed on FLD. And a dialog box saying "Finished the DSP code transmitting" appears. Click **OK** and then click **CLOSE** to close the application.
10. Turn off the unit.

Download Firmware for CPU (Mode 2)

1. Put the "CPU upgrade" folder into anywhere on your PC's hard disc.
2. Connect PC and the unit with the RS-232C cable.
3. Insert a thin rot to the hole and push the switch (SA50) inside to turn on the switch.

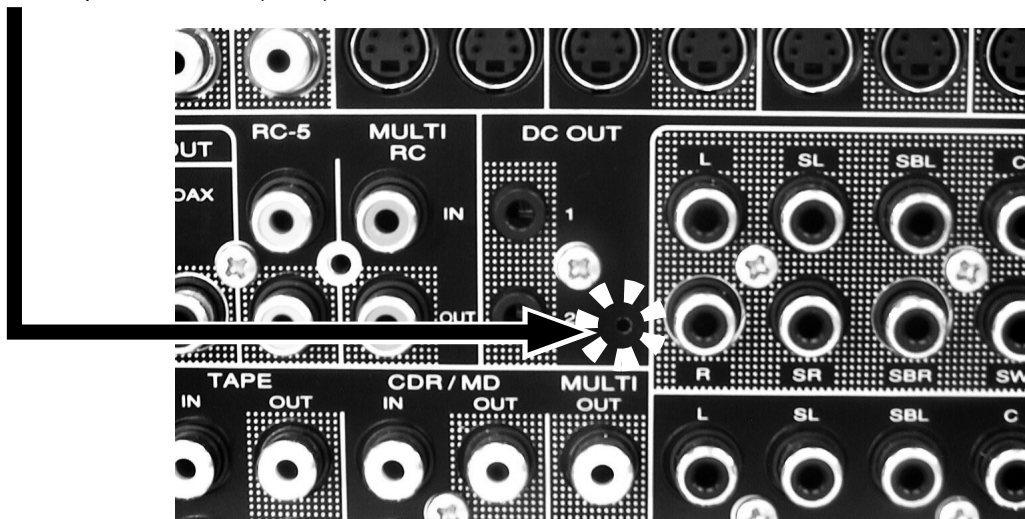

4. Turn on the power of the unit. (Confirm that the stand-by LED lights in green so the unit is in the boot mode.)
5. Launch "H8Download.exe" on PC.
6. Click **other files...** button in the dialog box to specify the file (XXXX.mot) to be upload.
7. Click **Connect** button. If the connection with the H8 μ -com is successfully made, a dialogue box saying "Success to the H8 micro processor connection" appears. If the connection fails, error message will appear.
8. Click **Send** button to start update.
9. If the firmware is updated successfully, a dialog box saying "Finished the firmware program sending" appears.
10. Click **CLOSE** button to close the application.
11. Disconnect Mains power cord.
12. Turn off the internal switch that has been turned on at step 3.
13. Turn on the unit.

Firmware Version Check

To check the versions of the firmware, see "Microprocessor (CPU), DSP Version and FLD Segment Check Mode" in "SERVICE PROGRAM" section.

11. POWER AMPLIFIER ADJUSTMENT

Idling Current Alignment

1. Each of the measurement points are provided with the two test points. Set a digital Voltage meter to DC voltage input, connect the meter to the test points at both contact points.
2. After the setup above, turn on the main switch and heat up the amplifier about 10 minutes.
3. Adjust variable resistors (R137, R138...R338) according to the digital voltmeter readings. The target setting value is 4.9 mV +/- 0.05 mV for each channels.

Settings : Master Volume --- Minimum

Speaker out --- No Load

Top lid --- OPEN

Channel	Alignment Point	Measurement Point
Front L	R137	J107
Center	R337	J106
Front R	R273	J103
Surr. L	R138	J105
Surr. R	R238	J108
SB	R338	J104

Time Table of Idling Current Rise

After Turning ON	Measurement Voltage (R ^{***})
5 min.	4.5 mV
10 min.	4.9 mV
20 min.	5.5 mV
30 min.	6.2 mV
40 min.	6.8 mV
60 min.	7.0 mV

12. SYSTEM ERROR

The CPU inside the unit monitors peripheral interfaces and if a trouble is detected the following information is displayed on the FLD.

1. Trouble in DSP

If communication with DSP is troubled more than 2 seconds, FLD shows below.

C	H	E	C	K		D	S	P				
---	---	---	---	---	--	---	---	---	--	--	--	--

* This display stays and sound is muted.

2. Trouble in RS-232C

If communication with RS-232C of panja system is troubled more than 2 seconds, FLD shows below.

C	H	E	C	K		2	3	2	C			
---	---	---	---	---	--	---	---	---	---	--	--	--

3. Trouble in EEPROM

If data from EEPROM(QU70) does not match, FLD shows below.

C	H	E	C	K		E	2	P				
---	---	---	---	---	--	---	---	---	--	--	--	--

* After displaying it, Back-up Data is reset to default.

4. Trouble in EEPROM I/F

If communication with EEPROM(QU70) is troubled more than 2 seconds, FLD shows below.

C	H	E	C	K		E	2	P		I	F	
---	---	---	---	---	--	---	---	---	--	---	---	--

5. Trouble in 5V Supply

If 5V supply to P604(DSP/CPU PCB) is troubled, FLD shows below.

C	H	E	C	K		P	O	W	5			
---	---	---	---	---	--	---	---	---	---	--	--	--

6. Trouble in Power Amplifier

If DC offset, over-current, over-heat, trouble in main transformer is detected, FLD shows below.

P	R	O	T	E	C	T						
---	---	---	---	---	---	---	--	--	--	--	--	--

* If a trouble is detected upon power on, CPU turns off the speaker relay. And if the trouble is not recovered within 2 seconds, CPU turns the unit into stand-by. If DC offset or over-current is detected on power on status, the speaker relay is turned off, and if over-heat, trouble in main transformer is detected, the unit turns into stand-by immediately.

12. TROUBLE SHOOTING

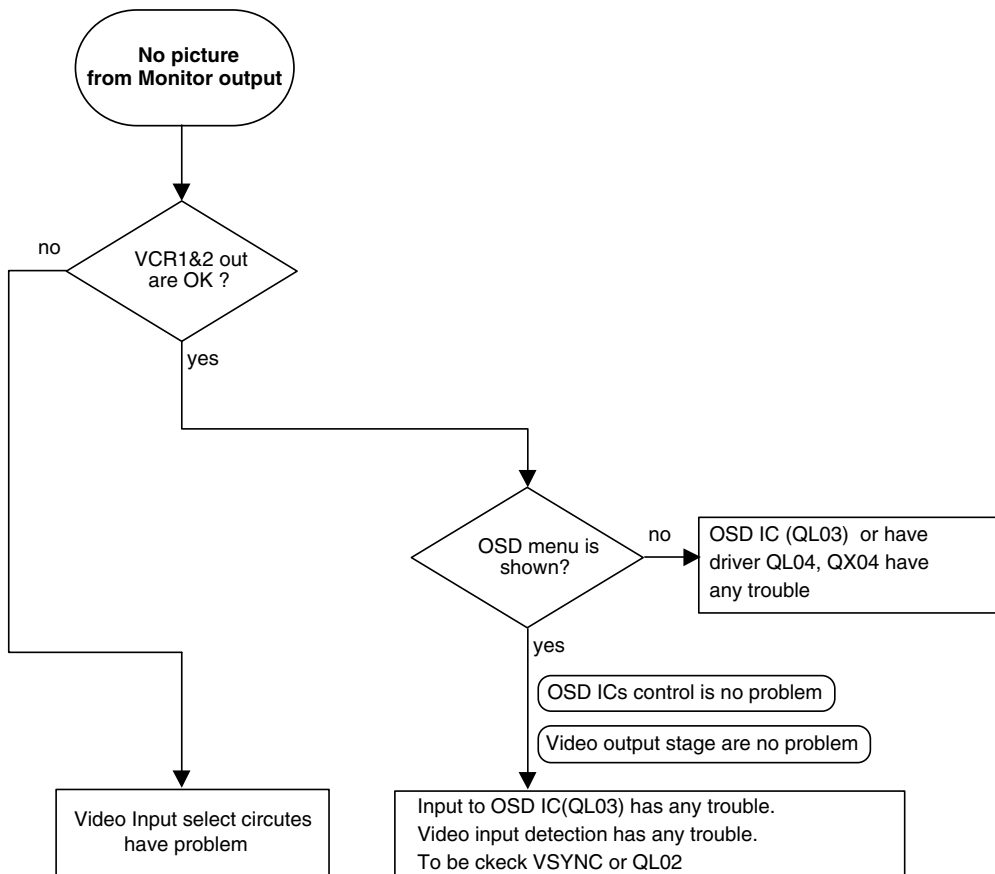
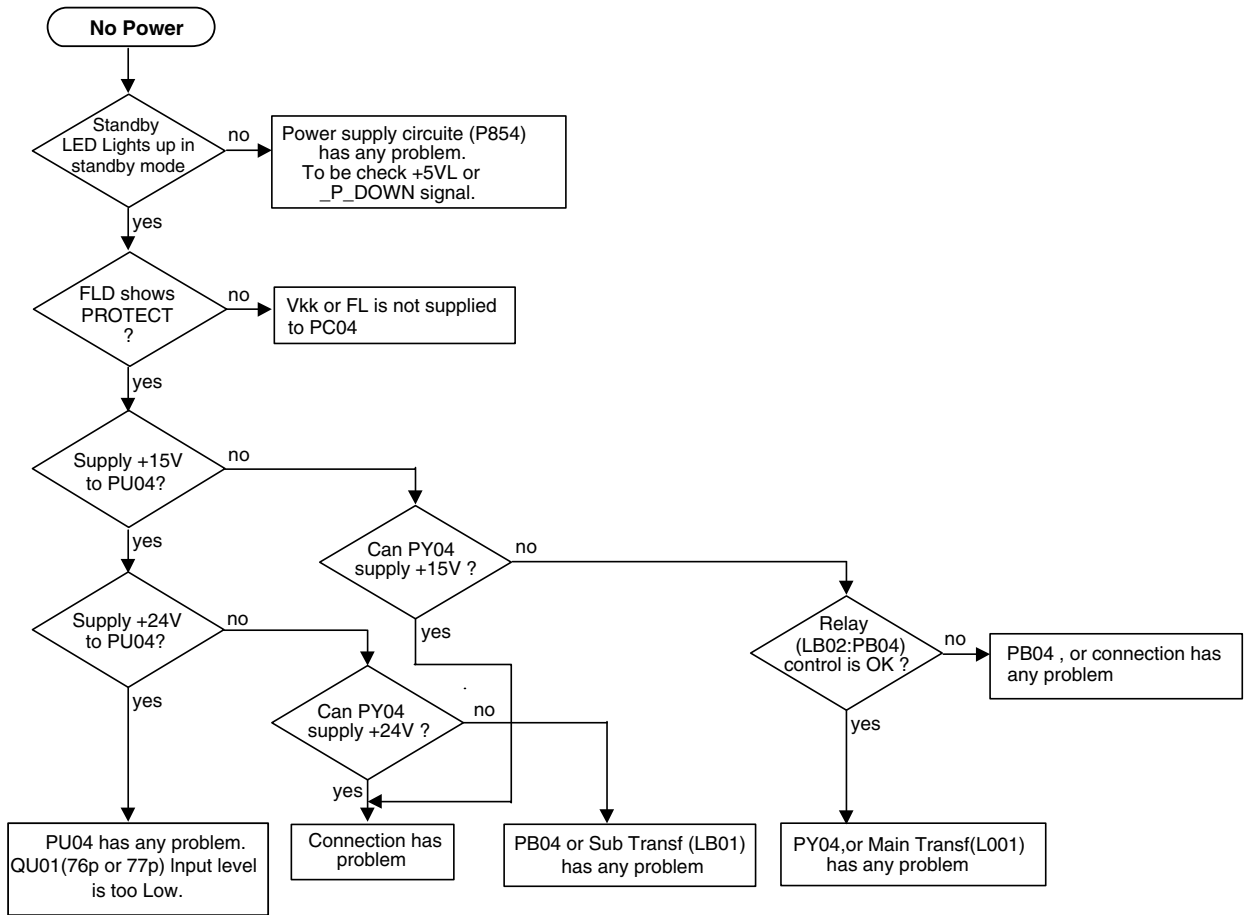

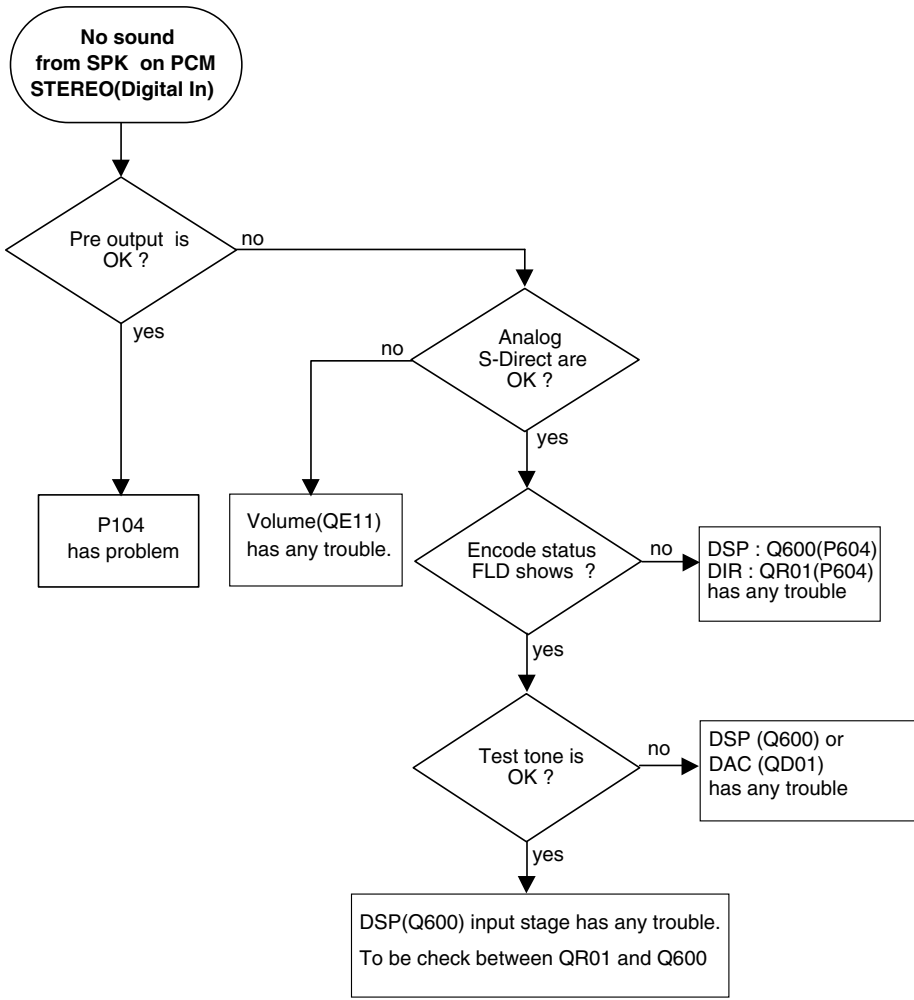
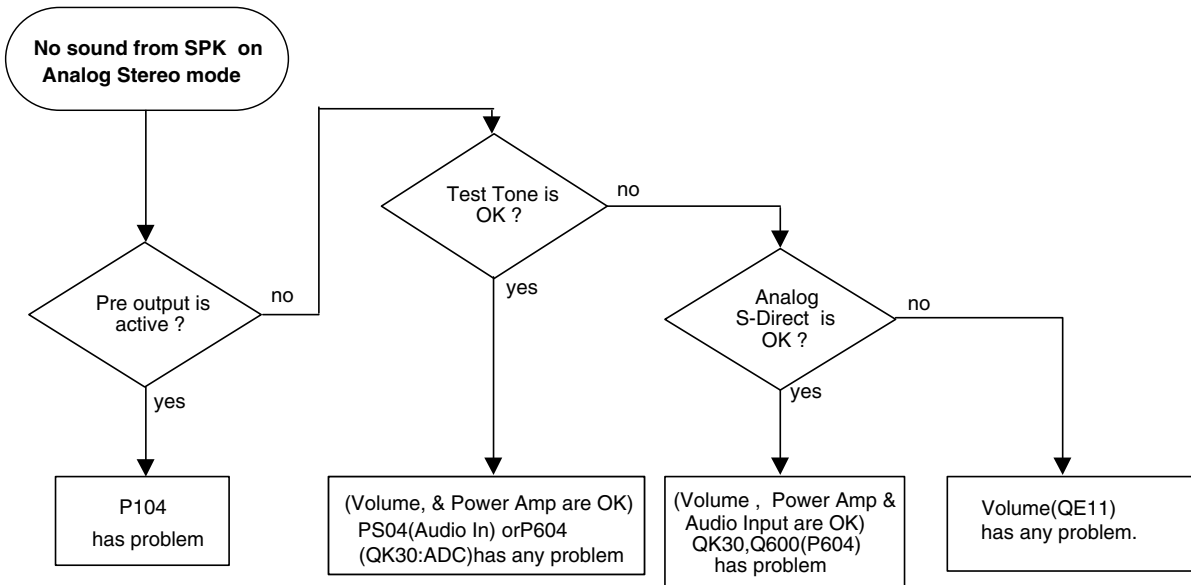

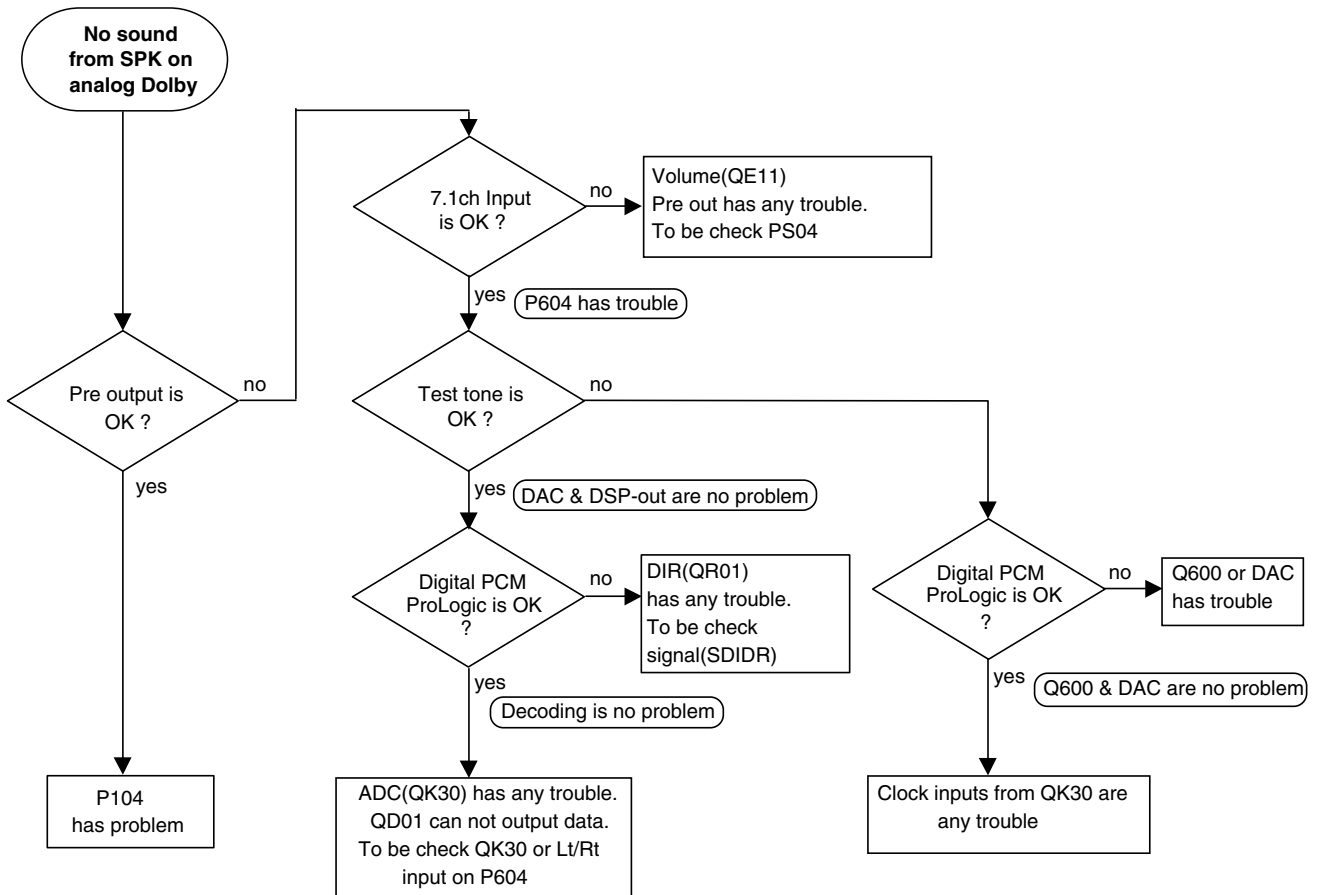
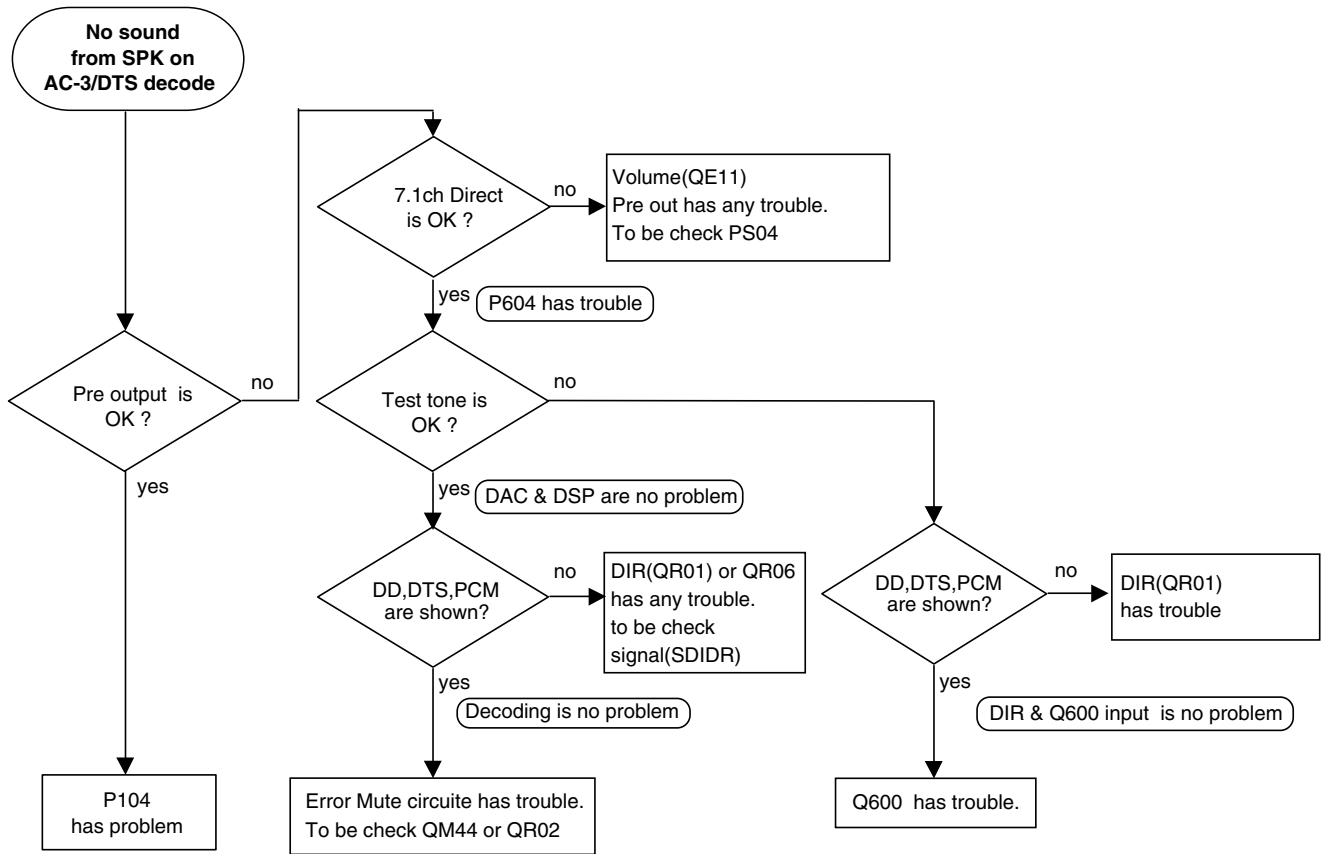

HOW TO FIND OUT DEFECTIVE POINT

AUDIO

Which signal path has problem Digital or Analog.

- Confirm 6.1 / 7.1ch INPUT Mode.
- Confirm S-Direct mode to analog input.
- Confirm Test Tone output.
- Confirm Multi Channel Stereo mode to analog input.
- Confirm Multi Channel Stereo mode to PCM input.

VIDEO

Which stage has problem Input, Output or OSD?

- Confirm VCR1 or VCR2 output.
- Confirm both Monitor outputs (S-Video & CVBS) to normal condition.
- Confirm Monitor output to system setup menu condition.
- Confirm Monitor output to OSD information (Super imposes).

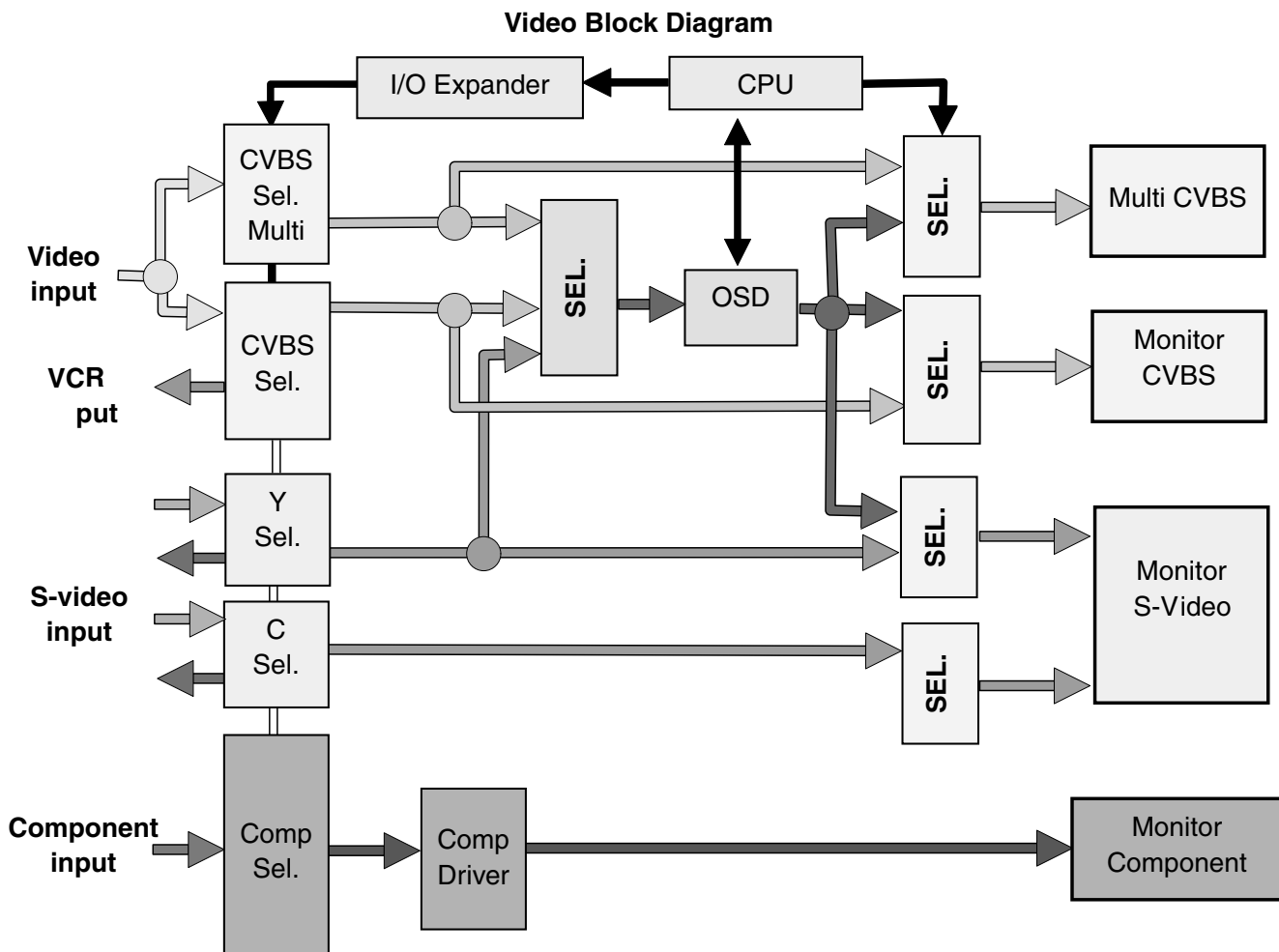

14. ELECTRICAL PARTS LIST

ASSIGNMENT OF COMMON PARTS CODES.

RESISTORS

R***: 1) GD05xxx140, Carbon film fixed resistor, ±5% 1/4W
 R***: 2) GD05xxx160, Carbon film fixed resistor, ±5% 1/6W

① — Resistance value

Examples ;

- ① Resistance value
- | | | | |
|----------------|----------------|-----------------|-----------------|
| 0.1 Ω 001 | 10 Ω 100 | 1 kΩ 102 | 100 kΩ 104 |
| 0.5 Ω 005 | 18 Ω 180 | 2.7 kΩ 272 | 680 kΩ 684 |
| 1 Ω 010 | 100 Ω 101 | 10 kΩ 103 | 1 MΩ 105 |
| 6.8 Ω 068 | 390 Ω 391 | 22 kΩ 223 | 4.7 MΩ 475 |

Note : Please distinguish 1/4W from 1/6W by the shape of parts used actually.

CAPACITORS

C***: CERAMIC CAP.

3) DD1xxx370, Ceramic capacitor
 Disc type
 Temp.coeff.P350 ~ N1000, 50V

② — Capacity value
 ③ — Tolerance

Examples ;

- ② Tolerance (Capacity deviation)
- | |
|-----------------|
| ±0.25 pF 0 |
| ±0.5 pF 1 |
| ±5% 5 |

* Tolerance of COMMON PARTS handled here are as follows :

- | | |
|----------------|----------|
| 0.5 pF ~ 5 pF | ±0.25 pF |
| 6 pF ~ 10 pF | ±0.5 pF |
| 12 pF ~ 560 pF | ±5% |

③ Capacity value

- | | | |
|-----------------|----------------|-----------------|
| 0.5 pF 005 | 3 pF 030 | 100 pF 101 |
| 1 pF 010 | 10 pF 100 | 220 pF 221 |
| 1.5 pF 015 | 47 pF 470 | 560 pF 561 |



C*** : CERAMIC CAP.

4) DK16xxx300, High dielectric constant ceramic capacitor
 Disc type
 Temp.chara. 2B4, 50V

④ — Capacity value

Examples ;

- ④ Capacity value
- | | | |
|-----------------|------------------|-------------------|
| 100 pF 101 | 1000 pF 102 | 10000 pF 103 |
| 470 pF 471 | 2200 pF 222 | |

C***: 5) ELECTROLY CAP. (), 6) FILM CAP. ()

5) EAxxx10, Electrolytic capacitor
 One-way lead type, Tolerance ±20%

⑤ — Working voltage
 ⑥ — Capacity value

Examples ;

- ⑤ Capacity value
- | | | |
|------------------|-----------------|------------------|
| 0.1 μF 104 | 4.7 μF 475 | 100 μF 107 |
| 0.33 μF 334 | 10 μF 106 | 330 μF 337 |
| 1 μF 105 | 22 μF 226 | 1100 μF 118 |
| | | 2200 μF 228 |

⑥ Working voltage

- | | |
|---------------|--------------|
| 6.3V 006 | 25V 025 |
| 10V 010 | 35V 035 |
| 16V 016 | 50V 050 |

6) DF15xxx350 — Plastic film capacitor
 DF15xxx310 — One-way type, Mylar ±5% 50V
 DF16xxx310 — Plastic film capacitor
 One-way type, Mylar ±10% 50V

⑦ — Capacity value

Examples ;

- ⑦ Capacity value
- | | | | |
|--------------------------|-----|--------------|-----|
| 0.001 μF (1000 pF) | 102 | 0.1 μF | 104 |
| 0.0018 μF | 182 | 0.56 μF | 564 |
| 0.01 μF | 103 | 1 μF | 105 |
| 0.015 μF | 153 | | |

NOTE : 1) The above CODES (R*** , R*** , C*** , C*** and C***) are omitted on the schematic diagram in some case.

- On the occasion, be confirmed the common parts on the parts list.
- Refer to "Common Parts List" for the other common parts (RI05, DD4, DK4).

NOTE ON SAFETY FOR FUSIBLE RESISTOR :

The suppliers and their type numbers of fusible resistors are as follows;

1. KOA Corporation

Part No. (MJI)	Type No. (KOA)	Description
NH05xxx140	RF25SxxxΩJ	(±5% 1/4W)
NH05xxx120	RF50SxxxΩJ	(±5% 1/2W)
NH85xxx110	RF73B2AxxxΩJ	(±5% 1/10W)
NH95xxx140	RF73B2ExxxΩJ	(±5% 1/4W)

* Resistance value (0.1 Ω – 10 kΩ)

2. Matsushita Electronic Components Co., Ltd

Part No. (MJI)	Type No. (MEC)	Description
NF05xxx140	ERD-2FCJxxx	(±5% 1/4W)
RF05xxx140		
NF02xxx140	ERD-2FCGxxx	(±2% 1/4W)
RF02xxx140		

* Resistance value

Examples ;

- * Resistance value
- | | | | |
|----------------|----------------|-----------------|-----------------|
| 0.1 Ω 001 | 10 Ω 100 | 1 kΩ 102 | 100 kΩ 104 |
| 0.5 Ω 005 | 18 Ω 180 | 2.7 kΩ 272 | 680 kΩ 684 |
| 1 Ω 010 | 100 Ω 101 | 10 kΩ 103 | 1 MΩ 105 |
| 6.8 Ω 068 | 390 Ω 391 | 22 kΩ 223 | 4.7 MΩ 475 |



ABBREVIATION AND MARKS

ANT. : ANTENNA	BATT. : BATTERY
CAP. : CAPACITOR	CER. : CERAMIC
CONN. : CONNECTING	DIG. : DIGITAL
HP : HEADPHONE	MIC. : MICROPHONE
μ-PRO : MICROPROCESSOR	REC. : RECORDING
RES. : RESISTOR	SPK : SPEAKER
SW : SWITCH	TRANSF : TRANSFORMER
TRIM. : TRIMMING	TRS. : TRANSISTOR
VAR. : VARIABLE	X'TAL : CRYSTAL

NOTE ON FUSE :

Regarding to all parts of parts code FS20xxx2xx, replace only with Wickmann-Werke GmbH, Type 372 non glass type fuse.

NOTE ON SAFETY :

Symbol  Fire or electrical shock hazard. Only original parts should be used to replaced any part marked with symbol  . Any other component substitution (other than original type), may increase risk of fire or electrical shock hazard.

安全上の注意 :

 がついている部品は、安全上重要な部品です。必ず指定されている部品番号の部品を使用して下さい。

POS. NO	VERS. COLOR	PART NO. (FOR EUR)	DESCRIPTION	PART NO. (MJJ)	POS. NO	VERS. COLOR	PART NO. (FOR EUR)	DESCRIPTION	PART NO. (MJJ)
RU47		nsp	CHIP 1kΩ ±5% 1/16W	NN05102610	▲ C816		OA68801620	ELECT. 6800µF 16V RA2	OA68801620
RU48		nsp	CHIP 47kΩ ±5% 1/16W	NN05473610	C817		nsp	ELECT. 100µF M 16V RA-2	OA10701620
RU49		nsp	CHIP 47kΩ ±5% 1/16W	NN05473610	C818		nsp	ELECT. 100µF M 16V RA-2	OA10701620
RU50		nsp	CHIP 10kΩ ±5% 1/16W	NN05103610	C820		nsp	ELECT. 100µF M 63V RA-2	OA10706320
					CN56		nsp	ELECT. 4.7µF M 16V RA-2	OA47601620
DU01		HZ21005000	P604-SEMICONDUCTORS CHIP DIODE 1SS301 DAN202U UMT	HZ21005000				P804-CAPACITORS (COMMON) HIGH DIELECTRIC CONSTANT CER. CAPACITOR ±10% 50V : [K/N : C175-C178 C275 C276 C375 C376]	
Q600		HC10014880	IC CS494001-CQ AUDIO DECODER	HC10014880					
Q601		HC60021000	IC 4M FLASH FPT-48P-M19	*HS03AJX0R					
Q603		HC010505K0	IC TC74VHCT32AFT	HC010505K0					
▲ Q680		HC36J25050	IC TA48025F(TE16L N)	HC36J25050					
▲ Q681		HC36J33050	IC TA48033F(TE16L N)	HC36J33050					
QD01		HC10012880	IC CS4382 24BIT DR=114 8CH-DAC	HC10012880					
QK01		HC10172090	IC NJM2115M	HC10172090					
QK02		HC10172090	IC NJM2115M	HC10172090					
QK03		HX342132A0	CHIP TRS. 2SC4213	HX342132A0	R171		NK05100010	METAL 10Ω ±5% 1W	NK05100010
QK04		HX342132A0	CHIP TRS. 2SC4213	HX342132A0	R172		NK05100010	METAL 10Ω ±5% 1W	NK05100010
QK05		BA10013050	DIG. TRS. RN2303(PNPX1 22k+22k	BA10013050	R271		NK05100010	METAL 10Ω ±5% 1W	NK05100010
QK30		HC10015880	IC CS5361-KSR A/D CONVERTER	HC10015880	R272		NK05100010	METAL 10Ω ±5% 1W	NK05100010
QR01		HC10418030	IC LC89057W-VF4-E DAIO	HC10418030	R371		NK05100010	METAL 10Ω ±5% 1W	NK05100010
QR02		HC007505K0	IC TC74VHCT08AFT EL X4 2INPUT AND	HC007505K0	R372		NK05100010	METAL 10Ω ±5% 1W	NK05100010
QR03		HC007505K0	IC TC74VHCT08AFT EL X4 2INPUT AND	HC007505K0	R802		NK05222010	METAL 2.2kΩ ±5% 1W ERG1SJ-E	NK05222010
QR04		HC80070500	IC TC74HCT7007AF SOP	HC80070500	R805		NK05222010	METAL 2.2kΩ ±5% 1W ERG1SJ-E	NK05222010
QU01		HC60028010	IC H8S/2398F-ZTAT	HC60028010	R811		NK05010120	METAL 1Ω ±5% 1/2W	NK05010120
QU02		HC10191990	IC ATMEL AT24C08 8PIN SOIC	HC10191990	R812		NK05010120	METAL 1Ω ±5% 1/2W	NK05010120
QU03		HC10204990	IC HIN202ECB 16LEAD WIDE BODY	HC10204990	RP91		NK05331010	METAL 330Ω ±5% 1W	NK05331010
QU04		HC10099540	IC S-80145ALMC-JA6-T2 50MSEC	HC10099540	RP92		NK05331010	METAL 330Ω ±5% 1W	NK05331010
QU06		BA10013050	DIG. TRS. RN2303(PNPX1 22k+22k	BA10013050					
L600		FC90020120	P604-MISCELLANEOUS FERRITE CORE BK1608HM102-T FERRIT BEADS	FC90020120				P804-RESISTORS (COMMON) CARBON FILM FIXED RES. ±5% 1/6W : RN51-RN59 RN71-RN80 RN95 RN96	
LU02		FC90020210	FERRITE CORE	FC90020210	▲ D801		HE20002990	DIODE 6GBU04 6A 400V	HE20002990
LU17		FM12223030	EMI FILTER NFM41R10C223T1/B1	FM12223030	▲ D802		HD20002710	DIODE 1D3 1A 200V	HD20002710
LU18		FM12223030	EMI FILTER NFM41R10C223T1/B1	FM12223030	▲ D814				
LU19		FC90020210	FERRITE CORE	FC90020210	D816		HD30681000	ZENER DIODE 6.8V	HD30681000
LU20		FC90020210	FERRITE CORE	FC90020210	D817		HD33001000	ZENER DIODE MTZ J 30V	HD33001000
LU38		FC90020210	FERRITE CORE	FC90020210	DN51		nsp	DIODE 1D3 1A 200V	HD20002710
LU40		FC90020210	FERRITE CORE	FC90020210	DN55				
LU44		FC90020210	FERRITE CORE	FC90020210	▲ DP91		HD20002710	DIODE 1D3 1A 200V	HD20002710
LU46		FC90020210	FERRITE CORE	FC90020210	▲ Q801		HC38912090	IC NJM7812FA +12V 1A	HC3891209F
LU67		FC90020210	FERRITE CORE	FC90020210	▲ Q802		HC39912090	IC NJM7912FA -12V 1A	HC3991209F
LU69		FC90020210	FERRITE CORE	FC90020210	▲ Q803		HC38905090	IC NJM7805FA +5V	HC3890509F
LU78		FC90020210	FERRITE CORE	FC90020210	▲ Q804		HC38905090	IC NJM7805FA +5V	HC3890509F
XR51		JX12006350	CRYSTAL SMD-49 12.288MHZ	JX12006350	QN51		HT110482B0	TRS. 2SA1048 Y OR GR	HT110482B0
XU01		FQ02005060	SERAMIC VIB. CSTCW-X 20.0MHZ	FQ02005060	QN55				
					QN56		BA20001000	DIG. TRS.	BA20001000
					QN59		HT324582B0	DTC114ES UN4211 10k 10k	HT324582B0
					QN60		HT324582B0	TRS. 2SC2458 Y OR GR	HT324582B0
					QN61		HT324582B0	TRS. 2SC2458 Y OR GR	HT324582B0
					QN62		HT110482B0	TRS. 2SA1048 Y OR GR	HT110482B0
					QP91		BA20001000	DIG. TRS.	BA20001000
					QP92		HT110482B0	DTC114ES UN4211 10k 10k	HT110482B0
								TRS. 2SA1048 Y OR GR	HT110482B0
▲ C801		OB15906360	ELECT. CAP 35XL60 AUDIO ALH6 BLACK 8724	OB15906360	J171		YT01040790	TERMINAL SPKR FL(A) FR(A)	YT01040790
▲ C802		OB15906360	ELECT. CAP 35XL60 AUDIO ALH6 BLACK 8724	OB15906360	J172		YT01040790	TERMINAL SPKR FL(B) FR(B)	YT01040790
▲ C803		OA22803520	ELECT. 2200µF M 35V RA-2	OA22803520	J173		YT01040790	TERMINAL SPKR SR CENTER	YT01040790
▲ C804		OA22803520	ELECT. 2200µF M 35V RA-2	OA22803520					
C805		nsp	ELECT. 100µF M 16V RA-2	OA10701620					
C806		nsp	ELECT. 100µF M 16V RA-2	OA10701620					
▲ C815		EA10901670	ELECT. CAP. 1000/16V RE3	EA10901670					

NOTE : "nsp" PART IS LISTED FOR REFERENCE ONLY, MARANTZ WILL NOT SUPPLY THESE PARTS.

SR7300/SR7300F (VERS. COLOR : 7300.....SR7300 ALL VERSION. 7300F.....SR7300F(OSE) ALL VERSION.

POS. NO	VERS. COLOR	PART NO. (FOR EUR)	DESCRIPTION	PART NO. (MJI)	POS. NO	VERS. COLOR	PART NO. (FOR EUR)	DESCRIPTION	PART NO. (MJI)
J174 LN51 }		YT01040790	TERMINAL SPKR SB SL	YT01040790	R***			PC04-RESISTORS (COMMON) CARBON FILM FIXED RES. ±5% 1/6W : RC01-RC04 RC09-RC32 RC36-RC40 RP01-RP06 RP12 RP13	
LN54 LN99 LP91		LY20240490	RELAY SPKR OUT	LY20240490				PC04-SEMICONDUCTORS ZENER DIODE MTZ J 3.3V	HD30331000
		LY20240520	RELAY AVSS OEG PCLH 10A	LY20240520	DP01		HD30331000		
		LY20240510	RELAY OEG OSA-SS-224DM3 HP OUT	LY20240510	QC01 QC02		HC10220090 HT30001000	IC NJU3430FG1 TRS.	HC10220090 HT30001000
			P854-BACK UP TRANS AC OUTLET FUSE CIRCUIT BOARD P854-CAPACITORS		QC04		HW10004210	2SC2458 2SC1740S 2SC3199 ETC. PHOTO UNIT RPM6936-V4 IR SENSOR	HW10004210
▲ C851		DK17103910	CER. DE1607-1F 103M-KH	DK17103910	QC05		BA10001000	DIG.TRS. DTA114ES UN4111 10k 10k	BA10001000
▲ C852		OA33802520	ELECT. 3300µF 25V RA2	OA33802520	QP01 QP02		HC10008090 HC10452050	IC NJM4558D-D IC TC74VHC08F	HC10008090 HC10452050
C855		nsp	ELECT. 100µF M 16V RA-2	OA10701620				PC04-MISCELLANEOUS	
▲ C857		OA47505020	ELECT. 4.7µF 50V M RA-2	OA47505020	JP04		YT02011730	TERMINAL YKF51-5584 1P Y/C TOP	YT02011730
			P854-RESISTORS 2.2MΩ ±10% 1/2W FOR UL	RC10225820	JP05		YT02030740	TERMINAL YKC21-5891 1L3P Y/W/R TOP	YT02030740
▲ R860	/U	nsp			SC01 }		SP01013310	PUSH SWITCH	SP01013310
			P854-RESISTORS (COMMON) CARBON FILM FIXED RES. ±5% 1/6W : R852-855		SC23 SC24		SR02010090	SKQNAE H/5MM 160 GF ALPS ROTARY SWITCH ROTARY ENCODER C12E 24PULSE	SR02010090
			P854-SEMICONDUCTORS		VC01		HQ31606920	DISPLAY UNIT CM2071C NORITAKE	HQ31606920
▲ D851		HD20002710	DIODE 1D3 1A 200V	HD20002710				PC54-SURR.ENCODER CIRCUIT BOARD	
▲ D856		HD30821000	ZENER DIODE 8.2V	HD30821000	R***			PC54-RESISTORS (COMMON) CARBON FILM FIXED RES. ±5% 1/6W : RC50-RC57 RC58:[/K/F/N] RC59:[/U]	
D859		HD20002710	DIODE 1D3 1A 200V	HD20002710	DC50		HI10099320	L.E.D. GL3ED8 SHARP	HI10099320
▲ D860		nsp	DIODE	HD20002000	QC50		BA10001000	DIG.TRS.	BA10001000
D862			1SS176 MA165 1SS254 30V 0.1A		QC51		BA10001000	DTA114ES UN4111 10k 10k DIG.TRS.	BA10001000
▲ Q851		HC38905090	IC NJM7805FA +5V	HC3890509F	QC55		SP01013310	DTA114ES UN4111 10k 10k DIG.TRS.	SP01013310
Q852		HC10011980	IC RESET IC (4.2V)	HC10011980	SC50		SP01013310	PUSH SWITCH SKQNAE H/5MM 160 GF ALPS	SP01013310
Q853		BA20001000	DIG.TRS.	BA20001000	SC51		SP01013310	PUSH SWITCH SKQNAE H/5MM 160 GF ALPS	SP01013310
			DTC114ES UN4211 10k 10k		SC52		SR02010100	ROTARY SWITCH ROTARY ENCODER C12E 24CLICK	SR02010100
Q854		HT110482B0	TRS. 2SA1048 Y OR GR	HT110482B0	SC60	/U	SP01013310	PUSH SWITCH SKQNAE H/5MM 160 GF ALPS	SP01013310
▲ F851	/K/N	FS10500850	FUSE 5.0 A 250V BS LISTED	FS10500850				PC74-AUX OPT CIRCUIT BOARD	
▲ F851	/U		FUSE 10A 250V UL CSA MITI GMB	FS11000530	JP70		YJ15000230	OPT. CONNECTOR TORX179L	YJ15000230
▲ F852	/K/N	FS10250850	FUSE 2.5 A 250V BS LISTED	FS10250850				PD04-DIG-IN/OUT PREOUT CIRCUIT BOARD	
▲ J860	/N	YJ04001640	JACK AC SOKET	YJ04001640				PD04-CAPACITORS	
▲ J860	/U		YKE31-0090 SEMKO		C901	/N	nsp	ELECT. 10µF M 50V RA-2	OA10605020
			JACK 2P AC OUTLET (CCT1304-0212)	YJ04002040	C903	/N	nsp	ELECT. 10µF M 50V RA-2	OA10605020
▲ L851		LY10090010	RELAY TV-8 OEG SDT-S-109DMR	LY10090010	C912	/N	nsp	ELECT. 10µF M 50V RA-2	OA10605020
▲ T851	/K/N	TS12813020	POWER TRANSF. BACKUP AC230V	TS12813020	C955 }	/K/N			
▲ T851	/U		POWER TRANSF. BACKUP AC120V	TS12813010	C955 }	/K/N	nsp	ELECT. 4.7µF M 50V RA-2	OA47505020
			P874-AC INLET CIRCUIT BOARD		C958	/K/N			
▲ J871	/K/N	YJ04002440	JACK 2P AC INLET PWI1910-H	YJ04002440					
▲ C881	/K/N	DK17471520	CER. DE091 B 471 -KX 250V	DK17471520					
▲ S881	/K/N	SP01013800	PUSH SWITCH AC POWER ESB92S17B	SP01013800					
			PC04-FRONT CIRCUIT BOARD PC04-CAPACITORS						
CC18		nsp	ELECT. 100µF M 50V RA-2	OA10705020					
			PC04-RESISTORS						
RC05		BW05473230	COMPO. RKC13BS473J ±5% P1.8	BW05473230					
RC06		BW05473230	COMPO. RKC13BS473J ±5% P1.8	BW05473230					
RC07		BW05473230	COMPO. RKC13BS473J ±5% P1.8	BW05473230					
RC08		BW05103330	COMPO. RKC13BS103J ±5% P1.8	BW05103330					

NOTE : "nsp" PART IS LISTED FOR REFERENCE ONLY, MARANTZ WILL NOT SUPPLY THESE PARTS.

POS. NO	VERS. COLOR	PART NO. (FOR EUR)	DESCRIPTION	PART NO. (MJ)	POS. NO	VERS. COLOR	PART NO. (FOR EUR)	DESCRIPTION	PART NO. (MJ)
C980 C983 CA02 CA06 CA17		nsp	ELECT. 100µF M 16V RA-2	OA10701620	QA63		BA10001000	DIG.TRS. DTA114ES UN4111 10k 10k	BA10001000
		nsp	ELECT. 47µF M 25V RA-2	OA47602520	QT02		BA20001000	DIG.TRS. DTC114ES UN4211 10k 10k	BA20001000
		nsp	ELECT. 47µF M 25V RA-2	OA47602520	QT04		BA10001000	DIG.TRS. DTA114ES UN4111 10k 10k	BA10001000
		nsp	ELECT. 47µF M 25V RA-2	OA47602520					
C***			PD04-CAPACITORS (COMMON) HIGH DIELECTRIC CONSTANT CER. CAPACITOR ±10% 50V : C906:[/N] C961-C962:[/K/N] C971 C972-C978 CA14 CT01-CT04:[/K/N/U] CT07:[/K/N/U] CT08:[/K/N/U]		J970	7300	YT02041350	PD04-MISCELLANEOUS TERMINAL YKC21-3925 2L4P FG BK NI	YT02041350
			PLASTIC FILM CAPACITOR ±5% 50V : CA07-CA09 CA15		J970	7300F	YT02041330	TERMINAL YKC21-3601 2L4P FG BK AU	YT02041330
C***					J971	7300	YT02041350	TERMINAL YKC21-3925 2L4P FG BK NI	YT02041350
					J971	7300F	YT02041330	TERMINAL YKC21-3601 2L4P FG BK AU	YT02041330
R***			PD04-RESISTORS (COMMON) CARBON FILM FIXED RES. ±5% 1/6W : R901-R904:[/N] R951-962:[/K/N] R963-R964:[/U] RA01-RA03 RA05-RA07 RA09-RA11 RA13-RA15 RA17 RA52-RA57 RA60 RA61 RA64-RA73 RT01:[/K/N/U] RT02:[/K/N/U]		JA01		YJ15000230	OPT. CONNECTOR TORX179L TOSLINK RECEIVER	YJ15000230
					JA02		YJ15000230	OPT. CONNECTOR TORX179L TOSLINK RECEIVER	YJ15000230
					JA03		YJ15000230	OPT. CONNECTOR TORX179L TOSLINK RECEIVER	YJ15000230
					JA04	7300	YT02030750	TERMINAL YKC21-4272 1L3P FS BK NI	YT02030750
					JA04	7300F	YT02030760	TERMINAL YKC21-4468 1L3P FS BK AU	YT02030760
					JA06	7300	YT02010780	TERMINAL 14X14 RA 1L1P BLK NI FLM-GND	YT02010780
DA01 DA06 DA50		nsp	DIODE 1SS176 MA165 1SS254 30V 0.1A	HD20002000	JA06	7300F	YT02010790	TERMINAL 14X14 RA 1L1P BLK AU FLM-GND	YT02010790
		nsp	DIODE 1SS176 MA165 1SS254 30V 0.1A	HD20002000	JA07		YJ15000220	OPT. CONNECTOR TOTX179L TOSLINK TRANSCEIVER	YJ15000220
		nsp	DIODE 1SS176 MA165 1SS254 30V 0.1A	HD20002000	JA50		YJ01004750	JACK LGA6502-0150 3.5MM MINI	YJ01004750
					JA51		YT02041260	TERMINAL 4P CINCH ORGX2 GRNX2 NI DUAL-GND	YT02041260
Q901 Q902	/N	HC10404030	IC LC72722 RDS DECODER	HC10404030	L902 L906	/N	nsp	0Ω ±5% 1/6W	GD05000160
	/N	HT30001000	TRS. 2SC2458 2SC1740S 2SC3199 ETC.	HT30001000	L912	/N	nsp	0Ω ±5% 1/6W	GD05000160
Q903	/N	BA20001000	DIG.TRS. DTC114ES UN4211 10k 10k	BA20001000	LA01	/N	TP41042030	PULSE TRANSF. PULSE TRNSF.(TPS247MN-0386AN)	TP41042030
Q904	/N	BA10001000	DIG.TRS. DTA114ES UN4111 10k 10k	BA10001000	SA50		SP02022320	PUSH SWITCH PUSH SW (SPUJ191000) W/KNOB	SP02022320
Q951 QA01 QA02	/K/N	HC10008090	IC NJM4558D-D	HC10008090	X901	/N	JX04003260	CRYSTAL 4.332MHZ AT-49	JX04003260
		HC700400U0	IC LC74HCU04	HC700400U0					
		HC700800B0	IC 74HC08 2-INPUT AND GATE H-CMOS	HC700800B0					
QA50 QA51 QA52		HT109501A0	TRS. 2SA950 GR R	HT109501A0			nsp	PF04-COMPONENT CIRCUIT BOARD	
		HT109501A0	TRS. 2SA950 GR R	HT109501A0			nsp	PF04-CAPACITORS	
		BA20001000	DIG.TRS. DTC114ES UN4211 10k 10k	BA20001000	CF51		nsp	ELECT. 47µF M 10V RA-2	OA47601020
QA53		BA20001000	DIG.TRS. DTC114ES UN4211 10k 10k	BA20001000	CF53		nsp	ELECT. 47µF M 10V RA-2	OA47601020
		BA20001000	DIG.TRS. DTC114ES UN4211 10k 10k	BA20001000	CF55		nsp	ELECT. 47µF M 10V RA-2	OA47601020
QA54		BA10001000	DIG.TRS. DTA114ES UN4111 10k 10k	BA10001000	CF57		nsp	ELECT. 47µF M 10V RA-2	OA47601020
		BA10001000	DIG.TRS. DTA114ES UN4111 10k 10k	BA10001000	CF59		nsp	ELECT. 47µF M 10V RA-2	OA47601020
QA55		BA10001000	DIG.TRS. DTA114ES UN4111 10k 10k	BA10001000	CF61		nsp	ELECT. 47µF M 10V RA-2	OA47601020
		BA20001000	DIG.TRS. DTC114ES UN4211 10k 10k	BA20001000	CF63		nsp	ELECT. 470µF M 6.3V RA-2	OA47700620
QA56		BA20001000	DIG.TRS. DTC114ES UN4211 10k 10k	BA20001000	CF66		nsp	ELECT. 470µF M 6.3V RA-2	OA47700620
		BA20001000	DIG.TRS. DTC114ES UN4211 10k 10k	BA20001000	CF69		nsp	ELECT. 470µF M 6.3V RA-2	OA47700620
QA57		BA10001000	DIG.TRS. DTA114ES UN4111 10k 10k	BA10001000	CF73		nsp	ELECT. 47µF M 10V RA-2	OA47601020
		BA10001000	DIG.TRS. DTA114ES UN4111 10k 10k	BA10001000	CF74		nsp	ELECT. 47µF M 10V RA-2	OA47601020
QA58		HW10006320	PHOTO UNIT PC-817 PHOTO CUPLER 1PAIR	HW10006320	CF76		nsp	ELECT. 47µF M 10V RA-2	OA47601020
		BA10001000	DIG.TRS. DTA114ES UN4111 10k 10k	BA10001000	CF78		nsp	ELECT. 47µF M 10V RA-2	OA47601020
QA59		BA10001000	DIG.TRS. DTA114ES UN4111 10k 10k	BA10001000	CF86		nsp	ELECT. 100µF M 10V RA-2	OA10701020
		BA20001000	DIG.TRS. DTC114ES UN4211 10k 10k	BA20001000	CF87		nsp	ELECT. 100µF M 10V RA-2	OA10701020
QA60		BA20001000	DIG.TRS. DTC114ES UN4211 10k 10k	BA20001000	CF88		nsp	ELECT. 10µF M 50V RA-2	OA10605020
		BA10001000	DIG.TRS. DTA114ES UN4111 10k 10k	BA10001000	CF90		nsp	ELECT. 10µF M 50V RA-2	OA10605020
QA61		BA10001000	DIG.TRS. DTA114ES UN4111 10k 10k	BA10001000				PF04-RESISTORS (COMMON)	
QA62		BA20001000	DIG.TRS. DTC114ES UN4211 10k 10k	BA20001000	R***			CARBON FILM FIXED RES. ±5% 1/6W : RF66 RF67	

NOTE : *nsp* PART IS LISTED FOR REFERENCE ONLY, MARANTZ WILL NOT SUPPLY THESE PARTS.

POS. NO	VERS. COLOR	PART NO. (FOR EUR)	DESCRIPTION	PART NO. (MJJ)	POS. NO	VERS. COLOR	PART NO. (FOR EUR)	DESCRIPTION	PART NO. (MJJ)
QF51		HC10229090	PF04-SEMICONDUCTORS IC NJM2584D VIDEO SEL 50MHZ	HC10229090	CX28		nsp	ELECT. 100µF M 10V RA-2	OA10701020
QF52		HC10230090	IC NJM2581D 3CH VIDEO AMP 50MHz	HC10230090	CX31		nsp	ELECT. 100µF M 10V RA-2	OA10701020
JF51	7300	YT02030720	PF04-MISCELLANEOUS TERMINAL YKC21-4310 1L3P	YT02030720	CX33		nsp	ELECT. 100µF M 10V RA-2	OA10701020
JF52	7300	YT02030720	TERMINAL YKC21-4059 1L3P	YT02030540	CX35		nsp	ELECT. 10µF M 50V RA-2	OA10605020
JF53	7300	YT02030540	TERMINAL YKC21-4310 1L3P	YT02030720	CX36		nsp	ELECT. 10µF M 50V RA-2	OA10605020
JF53	7300F	YT02030710	TERMINAL YKC21-4059 1L3P	YT02030540	CX39		nsp	ELECT. 100µF M 10V RA-2	OA10701020
JF53	7300F	YT02030540	TERMINAL YKC21-4075 1L3P	YT02030710	CX40		nsp	ELECT. 10µF M 50V RA-2	OA10605020
JU11	7300F	YP11000220	TERMINAL YKC21-4059 1L3P	YT02030540	CX41		nsp	ELECT. 10µF M 50V RA-2	OA10605020
JU11	7300F	YP11000220	PLUG DZ101A1-B2 RS232C	YP11000220	CX44		nsp	ELECT. 100µF M 10V RA-2	OA10701020
			PL04-CVBS Y/C CIRCUIT BOARD		CX47		nsp	ELECT. 10µF M 50V RA-2	OA10605020
			PL04-CAPACITORS		CX48		nsp	ELECT. 10µF M 50V RA-2	OA10605020
CF01		nsp	ELECT. 10µF M 50V RA-2	OA10605020	PL04 CAPACITORS (COMMON) HIGH DIELECTRIC CONSTANT CER. CAPACITOR ±10% 50V : CL27 CX46 CX49 PL04-RESISTORS (COMMON) CARBON FILM FIXED RES. ±5% 1/6W : RF06-RF10 RL13-RL19 RL23-RL26RL29-RL37 RL39-RL41 RL44 RL80-RL83 RX21-RX23 RX25-RX32 PL04-SEMICONDUCTORS				
CF04		nsp	ELECT. 470µF M 6.3V RA-2	OA47700620					
CF05		nsp	ELECT. 100µF M 10V RA-2	OA10701020	DL01		nsp	DIODE 1D3 1A 200V	HD20002710
CF08		nsp	ELECT. 100µF M 10V RA-2	OA10701020	DL80		nsp	DIODE 1SS176 MA165 1SS254 30V 0.1A	HD20002000
CF10		nsp	ELECT. 100µF M 10V RA-2	OA10701020	DL81		nsp	DIODE 1SS176 MA165 1SS254 30V 0.1A	HD20002000
CF14		nsp	ELECT. 10µF M 50V RA-2	OA10605020	DX01		nsp	DIODE	HD20002000
CF15		nsp	ELECT. 10µF M 50V RA-2	OA10605020	DX04		nsp	DIODE 1SS176 MA165 1SS254 30V 0.1A	HD20002000
CF16		nsp	ELECT. 10µF M 50V RA-2	OA10605020	QF01		HC10227090	IC NJM2595D	HC10227090
CF18		nsp	ELECT. 100µF M 10V RA-2	OA10701020	QF02		HC10119090	5IN 3OUT VIDEO SEL IC NJM2244D	HC10119090
CL01		nsp	ELECT. 10µF M 50V RA-2	OA10605020	QF03		HC709449B0	IC 74HC4094 16PIN DIP	HC709449B0
CL03		nsp	ELECT. 10µF M 50V RA-2	OA10605020	QL01		HC10227090	IC NJM2595D 5IN 3OUT VIDEO SEL	HC10227090
CL05		nsp	ELECT. 10µF M 50V RA-2	OA10605020	QL02		HC10228090	IC NJM2535D 3IN 1OUT VIDEO SEL	HC10228090
CL07		nsp	ELECT. 10µF M 50V RA-2	OA10605020	QL03		HC10377030	IC LC74781 OSD	HC10377030
CL09		nsp	ELECT. 470µF M 6.3V RA-2	OA47700620	QL04		HC10119090	IC NJM2244D 3IN 1OUT VIDEO SEL	HC10119090
CL11		nsp	ELECT. 470µF M 6.3V RA-2	OA47700620	QL05		HC709449B0	IC 74HC4094 16PIN DIP	HC709449B0
CL13		nsp	ELECT. 470µF M 6.3V RA-2	OA47700620	QL06		HT30001000	TRS. 2SC2458 2SC1740S 2SC3199 ETC.	HT30001000
CL16		nsp	ELECT. 100µF M 10V RA-2	OA10701020	QL07		HT30001000	TRS. 2SC2458 2SC1740S 2SC3199 ETC.	HT30001000
CL18		nsp	ELECT. 100µF M 10V RA-2	OA10701020	QL08	/K/N	BA20004000	DIG.TRS. DTC114TS UN4215 10k	BA20004000
CL19		nsp	ELECT. 10µF M 50V RA-2	OA10605020	QL09	/K/N	BA20004000	DIG.TRS. DTC114TS UN4215 10k	BA20004000
CL21		nsp	ELECT. 10µF M 50V RA-2	OA10605020	QL10	/K/N	BA10001000	DIG.TRS. DTA114ES UN4111 10k 10k	BA10001000
CL23		nsp	ELECT. 100µF M 10V RA-2	OA10701020	QL11		HT30001000	TRS. 2SC2458 2SC1740S 2SC3199 ETC.	HT30001000
CL24		nsp	ELECT. 10µF M 50V RA-2	OA10605020	QL12		BA10001000	DIG.TRS. DTA114ES UN4111 10k 10k	BA10001000
CL25		nsp	ELECT. 4.7µF M 50V RA-2	OA47505020	QL13		BA20001000	DIG.TRS. DTC114ES UN4211 10k 10k	BA20001000
CL26		nsp	ELECT. 1µF M 50V RA-2	OA10505020	QL14		HT30001000	TRS. 2SC2458 2SC1740S 2SC3199 ETC.	HT30001000
CL28		nsp	ELECT. 1µF M 50V RA-2	OA10505020	QL15		HT30001000	TRS. 2SC2458 2SC1740S 2SC3199 ETC.	HT30001000
CL31		nsp	ELECT. 100µF M 10V RA-2	OA10701020	QL16	▲	HC39905090	IC NJM7905FA	HC3990509F
CL37		nsp	ELECT. 10µF M 50V RA-2	OA10605020	QL80		HT10001000	TRS. A1048 A933S A1267 ETC.	HT10001000
CL41		nsp	ELECT. 10µF M 50V RA-2	OA10605020	QL81		BA10001000	DIG.TRS. DTA114ES UN4111 10k 10k	BA10001000
CL42		nsp	ELECT. 10µF M 50V RA-2	OA10605020	QX01		HC10227090	IC NJM2595D 5IN 3OUT VIDEO SEL	HC10227090
CL44		nsp	ELECT. 100µF M 10V RA-2	OA10701020					
CL48		nsp	ELECT. 10µF M 50V RA-2	OA10605020					
CL50		nsp	ELECT. 100µF M 10V RA-2	OA10701020					
CL53		nsp	ELECT. 10µF M 50V RA-2	OA10605020					
CL80		nsp	ELECT. 10µF M 50V RA-2	OA10605020					
CL82		nsp	ELECT. 2.2µF M 50V RA-2	OA22505020					
CL83		nsp	ELECT. 10µF M 50V RA-2	OA10605020					
CX01		nsp	ELECT. 10µF M 50V RA-2	OA10605020					
CX02		nsp	ELECT. 10µF M 50V RA-2	OA10605020					
CX04		nsp	ELECT. 10µF M 50V RA-2	OA10605020					
CX05		nsp	ELECT. 10µF M 50V RA-2	OA10605020					
CX07		nsp	ELECT. 10µF M 50V RA-2	OA10605020					
CX08		nsp	ELECT. 10µF M 50V RA-2	OA10605020					
CX10		nsp	ELECT. 10µF M 50V RA-2	OA10605020					
CX11		nsp	ELECT. 10µF M 50V RA-2	OA10605020					
CX13		nsp	ELECT. 470µF M 6.3V RA-2	OA47700620					
CX14		nsp	ELECT. 10µF M 50V RA-2	OA10605020					
CX17		nsp	ELECT. 470µF M 6.3V RA-2	OA47700620					
CX18		nsp	ELECT. 10µF M 50V RA-2	OA10605020					
CX21		nsp	ELECT. 470µF M 6.3V RA-2	OA47700620					
CX22		nsp	ELECT. 10µF M 50V RA-2	OA10605020					
CX26		nsp	ELECT. 100µF M 10V RA-2	OA10701020					

NOTE : "nsp" PART IS LISTED FOR REFERENCE ONLY, MARANTZ WILL NOT SUPPLY THESE PARTS.

SR7300/SR7300F (VERS. COLOR : 7300.....SR7300 ALL VERSION. 7300F.....SR7300F(OSE) ALL VERSION.

POS. NO	VERS. COLOR	PART NO. (FOR EUR)	DESCRIPTION	PART NO. (MJJ)	POS. NO	VERS. COLOR	PART NO. (FOR EUR)	DESCRIPTION	PART NO. (MJJ)
QX02		HC10227090	IC NJM2595D	HC10227090	CG11		nsp	ELECT. 22µF M 50V RA-2	OA22605020
QX03		HC10185090	IC NJM2264D	HC10185090	CG12		nsp	ELECT. 22µF M 50V RA-2	OA22605020
QX04		HC10119090	IC NJM2244D	HC10119090	CG13		nsp	ELECT. 10µF M 50V RA-2	OA10605020
QX05		HT10001000	TRS. A1048 A933S A1267 ETC.	HT10001000	CG14		nsp	ELECT. 10µF M 50V RA-2	OA10605020
			PL04-MISCELLANEOUS		CG19		nsp	ELECT. 47µF M 25V RA-2	OA47602520
JL01	7300	YT02030590	TERMINAL YKC21-3508 1L3P YEL FG NI	YT02030590	CG20		nsp	ELECT. 47µF M 25V RA-2	OA47602520
JL01	7300F	YT02030600	TERMINAL YKC21-3700 1L3P YEL FG AU	YT02030600	CG59		nsp	ELECT. 22µF M 50V RA-2	OA22605020
JL02	7300	YT02030590	TERMINAL YKC21-3508 1L3P YEL FG NI	YT02030590	CG62		nsp	ELECT. 10µF M 50V RA-2	OA10605020
JL02	7300F	YT02030600	TERMINAL YKC21-3700 1L3P YEL FG AU	YT02030600	CG63		nsp	ELECT. 47µF M 25V RA-2	OA47602520
JL03	7300	YT02021750	TERMINAL YKC21-4030 1L2P YEL FS NI	YT02021750	CG64		nsp	ELECT. 47µF M 25V RA-2	OA47602520
JL03	7300F	YT02021760	TERMINAL YKC21-4032 1L2P YEL FS NI	YT02021760	CG69		nsp	ELECT. 47µF M 25V RA-2	OA47602520
JX01	7300	YT02030350	TERMINAL YKF51-5514 3P S-TERMINAL NI	YT02030350	CG70		nsp	ELECT. 47µF M 25V RA-2	OA47602520
JX01	7300F	YT02030550	TERMINAL YKF51-5520 3P S-TERMINAL NI	YT02030550	CH09		DF15471350	FILM 470pF J M 50V	DF15471350
JX02	7300	YT02021320	TERMINAL YKF51-5510 2P S-TERMINAL NI	YT02021320	CH16		DF15471350	FILM 470pF J M 50V	DF15471350
JX02	7300F	YT02021520	TERMINAL YKF51-5519 2P S-TERMINAL NI	YT02021520	CJ09		DF15471350	FILM 470pF J M 50V	DF15471350
JX03	7300	YT02021320	TERMINAL YKF51-5510 2P S-TERMINAL NI	YT02021320	CJ16				
JX03	7300F	YT02021520	TERMINAL YKF51-5519 2P S-TERMINAL NI	YT02021520	CM01		nsp	ELECT. 10µF M 50V RA-2	OA10605020
LL01		LC13333800	CHOKO COIL 33uH LAL02TA330J	LC13333800	CM02		nsp	ELECT. 10µF M 50V RA-2	OA10605020
LL02		FM12223010	EMI FILTER DSS306-91-F-223Z	FM12223010	CM05		nsp	ELECT. 10µF M 50V RA-2	OA10605020
XL01		JX14001260	CRYSTAL AT49/14.31818MHZ	JX14001260	CM06		nsp	ELECT. 10µF M 50V RA-2	OA10605020
XL02	/K/N	JX17001260	CRYSTAL AT49 17.7MHZ	JX17001260	CM31		nsp	ELECT. 22µF M 50V RA-2	OA22605020
			PP94-HEAD PHONES OUT CIRCUIT BOARD		CM32		nsp	ELECT. 22µF M 50V RA-2	OA22605020
JP99		YJ01004240	JACK HLJ2307-01-3160 HEAD PHONES OUT	YJ01004240	CM33		nsp	ELECT. 10µF M 50V RA-2	OA10605020
			PS04-AUDIO FUNCTION/VOLUME CIRCUIT BOARD		CM34		nsp	ELECT. 10µF M 50V RA-2	OA10605020
			PS04-CAPACITORS		CM39		nsp	ELECT. 47µF M 25V RA-2	OA47602520
CE09		nsp	ELECT. 22µF M 50V RA-2	OA22605020	CM40		nsp	ELECT. 47µF M 25V RA-2	OA47602520
CE10		nsp	ELECT. 22µF M 50V RA-2	OA22605020	CQ03		nsp	ELECT. 10µF M 50V RA-2	OA10605020
CE11		nsp	ELECT. 22µF M 50V RA-2	OA22605020	CQ04		nsp	ELECT. 10µF M 50V RA-2	OA10605020
CE12		nsp	ELECT. 22µF M 50V RA-2	OA22605020	CQ07		nsp	ELECT. 10µF M 50V RA-2	OA10605020
CE13		nsp	ELECT. 10µF M 50V RA-2	OA10605020	CQ08		nsp	ELECT. 10µF M 50V RA-2	OA10605020
CE14		nsp	ELECT. 10µF M 50V RA-2	OA10605020	CQ11		nsp	ELECT. 10µF M 50V RA-2	OA10605020
CE19		nsp	ELECT. 47µF M 25V RA-2	OA47602520	CQ12		nsp	ELECT. 10µF M 50V RA-2	OA10605020
CE20		nsp	ELECT. 47µF M 25V RA-2	OA47602520	CQ15		nsp	ELECT. 10µF M 50V RA-2	OA10605020
CE59		nsp	ELECT. 22µF M 50V RA-2	OA22605020	CQ16		nsp	ELECT. 10µF M 50V RA-2	OA10605020
CE60		nsp	ELECT. 22µF M 50V RA-2	OA22605020	CQ19		nsp	ELECT. 10µF M 50V RA-2	OA10605020
CE61		nsp	ELECT. 22µF M 50V RA-2	OA22605020	CQ20		nsp	ELECT. 10µF M 50V RA-2	OA10605020
CE62		nsp	ELECT. 22µF M 50V RA-2	OA22605020	CQ23		nsp	ELECT. 10µF M 50V RA-2	OA10605020
CE63		nsp	ELECT. 10µF M 50V RA-2	OA10605020	CQ24		nsp	ELECT. 10µF M 50V RA-2	OA10605020
CE64		nsp	ELECT. 10µF M 50V RA-2	OA10605020	CQ27		nsp	ELECT. 10µF M 50V RA-2	OA10605020
CE69		nsp	ELECT. 47µF M 25V RA-2	OA47602520	CQ28		nsp	ELECT. 10µF M 50V RA-2	OA10605020
CE70		nsp	ELECT. 47µF M 25V RA-2	OA47602520	CQ31		nsp	ELECT. 10µF M 50V RA-2	OA10605020
CE81		nsp	ELECT. 47µF M 25V RA-2	OA47602520	CQ32		nsp	ELECT. 10µF M 50V RA-2	OA10605020
CE83		nsp	ELECT. 47µF M 25V RA-2	OA47602520	CQ73		nsp	ELECT. 100µF M 16V RA-2	OA10701620
CE85		nsp	ELECT. 47µF M 25V RA-2	OA47602520	CQ74		nsp	ELECT. 100µF M 16V RA-2	OA10701620
CE87		nsp	ELECT. 47µF M 25V RA-2	OA47602520	CQ76		nsp	ELECT. 100µF M 16V RA-2	OA10701620
CG09		nsp	ELECT. 22µF M 50V RA-2	OA22605020	CQ78		nsp	ELECT. 100µF M 16V RA-2	OA10701620
CG10		nsp	ELECT. 22µF M 50V RA-2	OA22605020	CQ89		nsp	ELECT. 100µF M 16V RA-2	OA10701620
					CQ90		nsp	ELECT. 100µF M 16V RA-2	OA10701620
					CS09		nsp	ELECT. 10µF M 50V RA-2	OA10605020
					CS10		nsp	ELECT. 10µF M 50V RA-2	OA10605020
					CS15		nsp	ELECT. 10µF M 50V RA-2	OA10605020
					CS16		nsp	ELECT. 10µF M 50V RA-2	OA10605020
					CS23		nsp	ELECT. 10µF M 50V RA-2	OA10605020
					CS24		nsp	ELECT. 10µF M 50V RA-2	OA10605020
					CS41		nsp	ELECT. 10µF M 50V RA-2	OA10605020
					CS42		nsp	ELECT. 10µF M 50V RA-2	OA10605020
					CS51		nsp	ELECT. 10µF M 50V RA-2	OA10605020
					CS52		nsp	ELECT. 10µF M 50V RA-2	OA10605020
					CS55		nsp	ELECT. 10µF M 50V RA-2	OA10605020
					CS58		nsp	ELECT. 10µF M 50V RA-2	OA10605020
					CS61		nsp	ELECT. 10µF M 50V RA-2	OA10605020
					CS62		nsp	ELECT. 10µF M 50V RA-2	OA10605020

NOTE : *nsp* PART IS LISTED FOR REFERENCE ONLY, MARANTZ WILL NOT SUPPLY THESE PARTS.

SR7300/SR7300F (VERS. COLOR : 7300.....SR7300 ALL VERSION. 7300F.....SR7300F(OSE) ALL VERSION.

POS. NO	VERS. COLOR	PART NO. (FOR EUR)	DESCRIPTION	PART NO. (MJI)	POS. NO	VERS. COLOR	PART NO. (FOR EUR)	DESCRIPTION	PART NO. (MJI)
			PS04-CAPACITORS (COMMON) PLASTIC FILM CAPACITOR ±5% 50V : CH01-HC08 CJ01-CJ08		QM27		BA10002000	DIG.TRS. DTA144ES UN4113 47k 47k	BA10002000
			PS04-RESISTORS (COMMON) CARBON FILM FIXED RES. ±5% 1/6W : RE09-RE12 RE15 RE16 RE19-RE33 RE44 RE45 RE59-RE62 RE65 RE66 RE69-RE83 RG09-RG12 RG15 RG16 RG19-RG33 RG59-RG62 RG65 RG66 RG69-RG84 RH01-RH32 RJ01-RJ32 RM01-RM04 RM31-RM34 RM37-RM51 RQ01-RQ04 RQ07-RQ12 RQ15-RQ20 RQ23-RQ32 RS01-RS48 RS51-RS58 RS61-RS68		QM28		BA20002000	DIG.TRS. DTC144ES UN4213 47k 47k	BA20002000
			PS04-SEMICONDUCTORS		QM29		BA10002000	DIG.TRS. DTA144ES UN4113 47k 47k	BA10002000
DM21		nsp	DIODE 1S176 MA165 1S254 30V 0.1A	HD20002000	QM31		BA10002000	DIG.TRS. DTA144ES UN4113 47k 47k	BA10002000
DM25		nsp	DIODE 1S176 MA165 1S254 30V 0.1A	HD20002000	QM32		BA20002000	DIG.TRS. DTC144ES UN4213 47k 47k	BA20002000
DM27		nsp	DIODE 1S176 MA165 1S254 30V 0.1A	HD20002000	QM33		BA10002000	DIG.TRS. DTA144ES UN4113 47k 47k	BA10002000
DQ81		nsp	DIODE 1S176 MA165 1S254 30V 0.1A	HD20002000	QM44		BA20002000	DIG.TRS. DTC144ES UN4213 47k 47k	BA20002000
DQ84		nsp	DIODE 1D3 1A 200V	HD20002710	QM45		BA20002000	DIG.TRS. DTC144ES UN4213 47k 47k	BA20002000
DQ85		nsp	DIODE 1D3 1A 200V	HD20002710	QQ01		HC10008090	IC NJM4558D-D	HC10008090
DQ86		nsp	DIODE 1D3 1A 200V	HD20002710	QQ04		HC38506090	IC NJM78M06FA	HC3850609F
QE03		HC10053090	IC NJM-2068-DD	HC10053090	▲ QQ61		HC39506090	IC NJM79M06FA	HC3950609F
QE05		HT805501B0	TRS. KTC2874 NPN	HT805501B0	▲ QQ62		HC10468050	IC TC9273N-013	HC10468050
QE08		HC10467050	IC TC9499N	HC10467050	QS01		HC10468050	IC TC9273N-013	HC10468050
QE11		HC10467050	IC TC9499N	HC10467050	QS02		HC10470050	IC TC9164AN	HC10470050
QE12		HC10053090	IC NJM-2068-DD	HC10053090	QS03		HC10469050	IC TC9162AN	HC10469050
QE53		HT805501B0	TRS. KTC2874 NPN	HT805501B0	QS05		HC10008090	IC NJM4558D-D	HC10008090
QE55		HT805501B0	TRS. KTC2874 NPN	HT805501B0	QS06		HC10008090	IC NJM4558D-D	HC10008090
QE58		HC10053090	IC NJM-2068-DD	HC10053090				PS04-MISCELLANEOUS	
QG03		HT805501B0	TRS. KTC2874 NPN	HT805501B0	JQ01	7300	YT02041350	TERMINAL YKC21-3925 2L4P FG BK NI	YT02041350
QG05		HT805501B0	TRS. KTC2874 NPN	HT805501B0	JQ01	7300F	YT02041330	TERMINAL YKC21-3601 2L4P FG BK AU	YT02041330
QG08		HC10053090	IC NJM-2068-DD	HC10053090	JQ02	7300	YT02041350	TERMINAL YKC21-3925 2L4P FG BK NI	YT02041350
QG53		HT805501B0	TRS. KTC2874 NPN	HT805501B0	JQ02	7300F	YT02041330	TERMINAL YKC21-3601 2L4P FG BK AU	YT02041330
QG55		HT805501B0	TRS. KTC2874 NPN	HT805501B0	JS01		YT02060660	TERMINAL	YT02060660
QG58		HC10053090	IC NJM-2068-DD	HC10053090	JS04	7300	YT02060660	TERMINAL YKC21-3796 2L6P FG W/R NI	YT02060660
QH01		HC10053090	IC NJM-2068-DD	HC10053090	JS01		YT02060670	TERMINAL	YT02060670
QH02		HC10053090	IC NJM-2068-DD	HC10053090	JS04	7300R	YT02060670	TERMINAL YKC21-3793 2L6P FG W/R AU	YT02060670
QJ01		HC10053090	IC NJM-2068-DD	HC10053090	WE99		YE01000630	CONNECTIVE CORD SIN-SIN UL1430 AWG20 L=6CM	YE01000630
QJ02		HC10053090	IC NJM-2068-DD	HC10053090					
QM01		HC10008090	IC NJM4558D-D	HC10008090					
QM13		HC10053090	IC NJM-2068-DD	HC10053090					
QM15		HT805501B0	TRS. KTC2874 NPN	HT805501B0					
QM18		BA10002000	DIG.TRS. DTA144ES UN4113 47k 47k	BA10002000					
QM21		BA20002000	DIG.TRS. DTC144ES UN4213 47k 47k	BA20002000					
QM22		BA10002000	DIG.TRS. DTA144ES UN4113 47k 47k	BA10002000					
QM23		BA20002000	DIG.TRS. DTC144ES UN4213 47k 47k	BA20002000					
QM24		BA10002000	DIG.TRS. DTA144ES UN4113 47k 47k	BA10002000					
QM25		BA20002000	DIG.TRS. DTC144ES UN4213 47k 47k	BA20002000					
QM26		BA10002000	DIG.TRS. DTA144ES UN4113 47k 47k	BA10002000					

NOTE : "nsp" PART IS LISTED FOR REFERENCE ONLY, MARANTZ WILL NOT SUPPLY THESE PARTS.

PS7300

POS. NO	VERS. COLOR	PART NO. (FOR EUR)	DESCRIPTION	PART NO. (MJJ)	POS. NO	VERS. COLOR	PART NO. (FOR EUR)	DESCRIPTION	PART NO. (MJJ)
			P104-6CHANNEL POWER AMPRIFIER CIRCUIT BOARD					R153-R164 R167 R168 R201-210 R215-218 R223-R236 R249 R250 R253-R264 R267 R268 R301-R310 R315-R318 R323-R326 R349 R350 R353-R364 RR367 R368 RN01 RN02-RN23	
C101			ELECT. 10µF M 50V RA-2	OA10605020					
C102			ELECT. 10µF M 50V RA-2	OA10605020					
C109			ELECT. 22µF M 50V RA-2	OA22605020					
C110			ELECT. 22µF M 50V RA-2	OA22605020					
C111			ELECT. 220µF M 63V RA-2	OA22706320	D101		P104-SEMICONDUCTORS		
C114									
C119			ELECT. 100µF M 16V RA-2	OA10701620	D108		DIODE	HD20002000	
C122									
C201			ELECT. 10µF M 50V RA-2	OA10605020	D109		1SS176 MA165 1SS254 30V 0.1A		
C202			ELECT. 10µF M 50V RA-2	OA10605020	D112		ZENER DIODE 3.9V	HD30391000	
C209			ELECT. 22µF M 50V RA-2	OA22605020	D113				
C210			ELECT. 22µF M 50V RA-2	OA22605020	D116		DIODE	HD20027010	
C211			ELECT. 220µF M 63V RA-2	OA22706320	D201		HSS81TD 150V 150MA AXIAL		
C214			ELECT. 220µF M 63V RA-2	OA22706320	D208		DIODE	HD20002000	
C219			ELECT. 220µF M 63V RA-2	OA22706320	D209		1SS176 MA165 1SS254 30V 0.1A		
C222			ELECT. 100µF M 16V RA-2	OA10701620	D212		ZENER DIODE 3.9V	HD30391000	
C301									
C302			ELECT. 10µF M 50V RA-2	OA10605020	D213				
C309			ELECT. 10µF M 50V RA-2	OA10605020	D216		DIODE	HD20027010	
C310			ELECT. 22µF M 50V RA-2	OA22605020	D301		HSS81TD 150V 150MA AXIAL		
C311			ELECT. 220µF M 63V RA-2	OA22706320	D308		DIODE	HD20002000	
C314			ELECT. 220µF M 63V RA-2	OA22706320	D309		1SS176 MA165 1SS254 30V 0.1A		
C319			ELECT. 100µF M 16V RA-2	OA10701620	D312		ZENER DIODE 3.9V	HD30391000	
C322									
CN01			ELECT. 4.7µF M 50V RA-2	OA47505020	D313				
CN04			ELECT. 4.7µF M 50V RA-2	OA47605020	D316		DIODE	HD20027010	
CN05			ELECT. 0.47µF M 50V RA-2	OA47405020	⚠ D821		HSS81TD 150V 150MA AXIAL		
							DIODE D10XB SIP 10A	HE20024290	
C***			P104-CAPACITORS (COMMON)		K101		SAP17P SAP17N O AND Y	HN000012A0	
			HIGH DIELECTRIC CONSTANT		K102		SAP17P SAP17N O AND Y	HN000012A0	
			CER. CAPACITOR ±10% 50V :		K201		SAP17P SAP17N O AND Y	HN000012A0	
			C103 C104 C107 C203 C204 C303		K202		SAP17P SAP17N O AND Y	HN000012A0	
			C304		K301		SAP17P SAP17N O AND Y	HN000012A0	
					K302		SAP17P SAP17N O AND Y	HN000012A0	
C***			PLASTIC FILM CAPACITOR		Q101		IC NJM-2068-DD	HC10053090	
			±5% 50V : C107 C108 C207 C208		Q103		TRS. 2SA1048 Y OR GR	HT110482B0	
			C307 C308		Q104		TRS. 2SA1048 Y OR GR	HT110482B0	
					Q105		TRS. 2SC2458 Y OR GR	HT324582B0	
			P104-RESISTORS		Q106		TRS. 2SC2458 Y OR GR	HT324582B0	
R137			TRIM. 220Ω VERTI	RA02210760	Q107				
R138			TRIM. 220Ω VERTI	RA02210760	Q110		TRS. 2SA970 GR OR BL	HT109702A0	
R139			METAL ERG1SJ470E 1W	NK05470010	Q111				
R146									
R237			TRIM. 220Ω VERTI	RA02210760	Q114		TRS. 2SC2240 GR OR BL	HT322402A0	
R238			TRIM. 220Ω VERTI	RA02210760	Q115				
R239			METAL ERG1SJ470E 1W	NK05470010	Q116		TRS. 2SA1145 O OR Y	HT111452A0	
R246									
R337			TRIM. 220Ω VERTI	RA02210760	Q117		TRS. 2SC2705 O OR Y	HT327052A0	
R338			TRIM. 220Ω VERTI	RA02210760	Q118		TRS. 2SC2705 O OR Y	HT327052A0	
R339			METAL ERG1SJ470E 1W	NK05470010	⚠ Q119		IC SAP17N O AND Y	HC20002080	
R346									
RN99			VARISTOR	HP00029230	⚠ Q120		IC SAP17N O AND Y	HC20002080	
			PTFM04BD222Q2N34B0 100C		⚠ Q121		IC SAP17P O AND Y	HC20001080	
					⚠ Q122		IC SAP17P O AND Y	HC20001080	
					Q123		TRS. 2SC2240 GR OR BL	HT322402A0	
					Q124		TRS. 2SC2240 GR OR BL	HT322402A0	
					Q201		IC NJM-2068-DD	HC10053090	
			P104-RESISTORS (COMMON)		Q203		TRS. 2SA1048 Y OR GR	HT110482B0	
			CARBON FILM FIXED RES.		Q204		TRS. 2SA1048 Y OR GR	HT110482B0	
			±5% 1/6W : R101-R110 R115-R118		Q205		TRS. 2SC2458 Y OR GR	HT324582B0	
			R123-R126 R135 R136 R149 R150		Q206		TRS. 2SC2458 Y OR GR	HT324582B0	

NOTE : *nsp* PART IS LISTED FOR REFERENCE ONLY, MARANTZ WILL NOT SUPPLY THESE PARTS.

PS7300

POS. NO	VERS. COLOR	PART NO. (FOR EUR)	DESCRIPTION	PART NO. (MJ)	POS. NO	VERS. COLOR	PART NO. (FOR EUR)	DESCRIPTION	PART NO. (MJ)
Q207			TRS. 2SA970 GR OR BL	HT109702A0	C625			CER. 0.1µF GRM39F104Z16	DK98104200
Q210					C680			CER. 0.1µF GRM39F104Z16	DK98104200
Q211			TRS. 2SC2240 GR OR BL	HT322402A0	C681			CER. 0.1µF GRM39F104Z16	DK98104200
Q214					C682			TANTL.CHIP 100µF 6.3V	EY10700620
Q215			TRS. 2SA1145 O OR Y	HT111452A0	C683			CER. 0.1µF GRM39F104Z16	DK98104200
Q216			TRS. 2SA1145 O OR Y	HT111452A0	C684			CER. 0.1µF GRM39F104Z16	DK98104200
Q217			TRS. 2SC2705 O OR Y	HT327052A0	C685			TANTL.CHIP 100µF 6.3V	EY10700620
Q218			TRS. 2SC2705 O OR Y	HT327052A0	C687			CER. 1µF 10V F	DK98105200
▲ Q219			IC SAP17N O AND Y	HC20002080	CD01			CER. 0.1µF GRM39F104Z16	DK98104200
▲ Q220			IC SAP17N O AND Y	HC20002080	CD02			TANTL.CHIP 22µF 6.3V	EY22600620
▲ Q221			IC SAP17P O AND Y	HC20001080	CD03			CER. 0.1µF GRM39F104Z16	DK98104200
▲ Q222			IC SAP17P O AND Y	HC20001080	CD04			TANTL.CHIP 22µF 6.3V	EY22600620
Q223			TRS. 2SC2240 GR OR BL	HT322402A0	CD05			CER. 100pF ±5% CG 50V GR39	DD95101300
Q224			TRS. 2SC2240 GR OR BL	HT322402A0	CD06			CER. 0.1µF GRM39F104Z16	DK98104200
Q301			IC NJM-2068-DD	HC10053090	CD07			TANTL.CHIP 1µF 50V	EY10505020
Q303			TRS. 2SA1048 Y OR GR	HT110482B0	CD08			CER. 0.1µF GRM39F104Z16	DK98104200
Q304			TRS. 2SA1048 Y OR GR	HT110482B0	CD09			TANTL.CHIP 47µF 6.3V	EY47600620
Q305			TRS. 2SC2458 Y OR GR	HT324582B0	CD10			CER. 0.1µF GRM39F104Z16	DK98104200
Q306			TRS. 2SC2458 Y OR GR	HT324582B0	CD11			TANTL.CHIP 100µF 6.3V	EY10700620
Q307					CD12			CER. 0.1µF GRM39F104Z16	DK98104200
Q310			TRS. 2SA970 GR OR BL	HT109702A0	CD13			TANTL.CHIP 22µF 6.3V	EY22600620
Q311					CK01				
Q314			TRS. 2SC2240 GR OR BL	HT322402A0	CK04			TANTL.CHIP 22µF 6.3V	EY22600620
Q315			TRS. 2SA1145 O OR Y	HT111452A0	CK05				
Q316			TRS. 2SA1145 O OR Y	HT111452A0	CK08			CER. 100pF ±5% CG 50V GR39	DD95101300
Q317			TRS. 2SC2705 O OR Y	HT327052A0	CK09			CER. 1000pF ±10% B 50V	DK96102300
Q318			TRS. 2SC2705 O OR Y	HT327052A0	CK10			CER. 1000pF ±10% B 50V	DK96102300
▲ Q319			IC SAP17N O AND Y	HC20002080	CK11				
▲ Q320			IC SAP17N O AND Y	HC20002080	CK16			CER. 0.1µF GRM39F104Z16	DK98104200
▲ Q321			IC SAP17P O AND Y	HC20001080	CK30			CER. 470pF	DK96471300
▲ Q322			IC SAP17P O AND Y	HC20001080	CK31			CER. 0.1µF GRM39F104Z16	DK98104200
Q323			TRS. 2SC2240 GR OR BL	HT322402A0	CK32			TANTL.CHIP 22µF 6.3V	EY22600620
Q324			TRS. 2SC2240 GR OR BL	HT322402A0	CK33			CER. 0.1µF GRM39F104Z16	DK98104200
QN01			IC TA7317P	HC10042050	CK34			TANTL.CHIP 22µF 6.3V	EY22600620
QN02			TRS. 2SA970 GR OR BL	HT109702A0	CK35			CER. 0.1µF GRM39F104Z16	DK98104200
QN03			TRS. 2SC2458 Y OR GR	HT324582B0	CK36			TANTL.CHIP 22µF 6.3V	EY22600620
QN04			DIG.TRS. DTC114ES UN4211 10k 10k	BA20001000	CK37			CER. 0.1µF GRM39F104Z16	DK98104200
			P604-DSP & UCOM BLOCK CIRCUIT BOARD		CK38			TANTL.CHIP 10µF 16V	EY10601620
			P604-CAPACITORS		CK39			CER. 0.1µF GRM39F104Z16	DK98104200
C600			CER. 0.1µF GRM39F104Z16	DK98104200	CK40			TANTL.CHIP 10µF 16V	EY10601620
C601			CER. 0.1µF GRM39F104Z16	DK98104200	CR01			CER. 0.1µF GRM39F104Z16	DK98104200
C602			TANTL.CHIP 22µF 6.3V	EY22600620	CR02			CER. 0.1µF GRM39F104Z16	DK98104200
C603			CER. 0.1µF GRM39F104Z16	DK98104200	CR03			TANTL.CHIP 22µF 6.3V	EY22600620
C604			TANTL.CHIP 22µF 6.3V	EY22600620	CR04			CER. 0.1µF GRM39F104Z16	DK98104200
C605			CER. 0.1µF GRM39F104Z16	DK98104200	CR05			CER. 0.022µF	DK98223300
C606			CER. 0.1µF GRM39F104Z16	DK98104200	CR06			CER. 0.1µF GRM39F104Z16	DK98104200
C607			CER. 0.1µF GRM39F104Z16	DK98104200	CR07			TANTL.CHIP 22µF 6.3V	EY22600620
C608			TANTL.CHIP 22µF 6.3V	EY22600620	CR08			CER. 0.1µF GRM39F104Z16	DK98104200
C609			CER. 0.1µF GRM39F104Z16	DK98104200	CR09			TANTL.CHIP 22µF 6.3V	EY22600620
C610			TANTL.CHIP 22µF 6.3V	EY22600620	CR10			CER. 0.1µF GRM39F104Z16	DK98104200
C611			CER. 0.1µF GRM39F104Z16	DK98104200	CR11			TANTL.CHIP 22µF 6.3V	EY22600620
C612			CER. 0.1µF GRM39F104Z16	DK98104200	CR12			CER. 22pF ±5% CG 50V GR39	DD95220300
C613			TANTL.CHIP 22µF 6.3V	EY22600620	CR13			CER. 22pF ±5% CG 50V GR39	DD95220300
C614			TANTL.CHIP 2.2µF 50V	EY22505020	CR14			CER. 0.1µF GRM39F104Z16	DK98104200
C615			CER. 68pF (GR39)	DD95680300	CR15			CER. 100pF ±5% CG 50V GR39	DD95101300
C616			CER. 1200pF	DK96122300	CR16			CER. 0.1µF GRM39F104Z16	DK98104200
C617			CER. 0.01µF ±10% B 25V	DK96103200	CR17			TANTL.CHIP 22µF 6.3V	EY22600620
C618			TANTL.CHIP 47µF 4V	EY47600420	CR18			CER. 0.1µF GRM39F104Z16	DK98104200
C619			CER. 0.1µF GRM39F104Z16	DK98104200	CR19			CER. 0.1µF GRM39F104Z16	DK98104200
C620			CER. 0.1µF GRM39F104Z16	DK98104200	CR69			CER. 0.1µF GRM39F104Z16	DK98104200
C621			TANTL.CHIP 22µF 6.3V	EY22600620	CU01			CER. 0.1µF GRM39F104Z16	DK98104200
C622			CER. 0.1µF GRM39F104Z16	DK98104200	CU02			TANTL.CHIP 22µF 6.3V	EY22600620
C623			CER. 0.1µF GRM39F104Z16	DK98104200	CU03			CER. 0.1µF GRM39F104Z16	DK98104200
					CU04			TANTL.CHIP 22µF 6.3V	EY22600620
					CU05			CER. 0.1µF GRM39F104Z16	DK98104200
					CU06			CER. 0.1µF GRM39F104Z16	DK98104200
					CU07			TANTL.CHIP 22µF 6.3V	EY22600620

NOTE : "nsp" PART IS LISTED FOR REFERENCE ONLY, MARANTZ WILL NOT SUPPLY THESE PARTS.

PS7300

POS. NO	VERS. COLOR	PART NO. (FOR EUR)	DESCRIPTION	PART NO. (MJJ)	POS. NO	VERS. COLOR	PART NO. (FOR EUR)	DESCRIPTION	PART NO. (MJJ)
CU11			CER. 0.1µF GRM39F104Z16	DK98104200	RK15			CHIP 100kΩ ±5% 1/16W	NN05104610
CU12			CER. 0.1µF GRM39F104Z16	DK98104200	RK16			CHIP 100kΩ ±5% 1/16W	NN05104610
CU13			TANTL.CHIP 22µF 6.3V	EY22600620	RK17			CHIP 2.7kΩ ±5% 1/16W	NN05272610
CU14					RK18			CHIP 2.7kΩ ±5% 1/16W	NN05272610
CU20			CER. 0.1µF GRM39F104Z16	DK98104200	RK19			CHIP 2.2kΩ ±5% 1/16W	NN05222610
CU21					RK20			CHIP 2.2kΩ ±5% 1/16W	NN05222610
CU22			CER. 10pF ±0.5pF CH 50V GR39	DD91100300	RK21			CHIP 1MΩ ±5% 1/16W	NN05105610
CU23			CER. 0.47µF F 16V	DK98474200	RK30			CHIP 10kΩ ±5% 1/16W	NN05103610
CU80			CER. 0.1µF GRM39F104Z16	DK98104200	RK31			CHIP 5.6kΩ ±5% 1/16W	NN05562610
CU81			TANTL.CHIP 220µF 10V	EY22701020	RK32			CHIP 27Ω ±5% 1/16W	NN05270610
CU82			TANTL.CHIP 100µF 10V	EY10701020	RK33			CHIP 56kΩ ±5% 1/16W	NN05563610
CU83			TANTL.CHIP 220µF 10V	EY22701020	RR01			CHIP 33Ω ±5% 1/16W	NN05330610
			TANTL.CHIP 220µF 10V	EY22701020	RR02			CHIP 220Ω ±5% 1/16W	NN05221610
					RR03				
			P604-RESISTORS						
R600			CHIP 3.3kΩ ±5% 1/16W	NN05332610				CHIP 100Ω ±5% 1/16W	NN05101610
R601			CHIP 3.3kΩ ±5% 1/16W	NN05332610	RR09				
R602			CHIP 3.3kΩ ±5% 1/16W	NN05332610	RR10			CHIP 1MΩ ±5% 1/16W	NN05105610
R603			CHIP 10kΩ ±5% 1/16W	NN05103610	RR11				
R604			CHIP 3.3kΩ ±5% 1/16W	NN05332610				CHIP 10kΩ ±5% 1/16W	NN05103610
R605			CHIP 3.3kΩ ±5% 1/16W	NN05332610	RR14				
R606			CHIP 10kΩ ±5% 1/16W	NN05103610	RR15			CHIP 3.3kΩ ±5% 1/16W	NN05332610
R607			CHIP 10kΩ ±5% 1/16W	NN05103610	RR16			CHIP 22kΩ ±5% 1/16W	NN05223610
R608			CHIP 5.6kΩ ±5% 1/16W	NN05562610	RR17			CHIP 47kΩ ±5% 1/16W	NN05473610
R609			CHIP 3.3kΩ ±5% 1/16W	NN05332610	RR18			CHIP 33Ω ±5% 1/16W	NN05330610
R610					RR19			CHIP 33Ω ±5% 1/16W	NN05330610
R618			CHIP 10kΩ ±5% 1/16W	NN05103610	RU01			CHIP 5.6kΩ ±5% 1/16W	NN05562610
R619			CHIP 1.5kΩ ±5% 1/16W	NN05152610	RU02			CHIP 22kΩ ±5% 1/16W	NN05223610
R620					RU03				
R640			CHIP 10kΩ ±5% 1/16W	NN05103610				CHIP 47kΩ ±5% 1/16W	NN05473610
R641			CHIP 33Ω ±5% 1/16W	NN05330610	RU07				
R642			CHIP 10kΩ ±5% 1/16W	NN05103610	RU08			CHIP 22kΩ ±5% 1/16W	NN05223610
R643					RU09			CHIP 47kΩ ±5% 1/16W	NN05473610
R647			CHIP 33Ω ±5% 1/16W	NN05330610	RU10			CHIP 47kΩ ±5% 1/16W	NN05473610
R648					RU11			CHIP 47kΩ ±5% 1/16W	NN05473610
R653			CHIP 10kΩ ±5% 1/16W	NN05103610	RU12			CHIP 10kΩ ±5% 1/16W	NN05103610
R654			CHIP 1.5kΩ ±5% 1/16W	NN05152610	RU17			CHIP 0Ω ±5% 1/16W	NN05000610
R655			CHIP 10kΩ ±5% 1/16W	NN05103610	RU19			CHIP 47kΩ ±5% 1/16W	NN05473610
R656			CHIP 10kΩ ±5% 1/16W	NN05103610	RU20			CHIP 47kΩ ±5% 1/16W	NN05473610
R658			CHIP 10kΩ ±5% 1/16W	NN05103610	RU21			CHIP 4.7kΩ ±5% 1/16W	NN05472610
R659			CHIP 5.6kΩ ±5% 1/16W	NN05562610	RU22			CHIP 4.7kΩ ±5% 1/16W	NN05472610
R660			CHIP 10kΩ ±5% 1/16W	NN05103610	RU23			CHIP 4.7kΩ ±5% 1/16W	NN05472610
R661			CHIP 10kΩ ±5% 1/16W	NN05103610	RU24			CHIP 47kΩ ±5% 1/16W	NN05473610
R662			CHIP 10kΩ ±5% 1/16W	NN05103610	RU25			CHIP 47kΩ ±5% 1/16W	NN05473610
R663			CHIP 3.3kΩ ±5% 1/16W	NN05332610	RU26			CHIP 39kΩ ±5% 1/16W	NN05393610
R664			CHIP 10kΩ ±5% 1/16W	NN05103610	RU27			CHIP 56kΩ ±5% 1/16W	NN05563610
R665			CHIP 5.6kΩ ±5% 1/16W	NN05562610	RU28			CHIP 47kΩ ±5% 1/16W	NN05473610
R666			CHIP 10kΩ ±5% 1/16W	NN05103610	RU30				
R672			CHIP 10kΩ ±5% 1/16W	NN05103610				CHIP 47kΩ ±5% 1/16W	NN05473610
R673			CHIP 10kΩ ±5% 1/16W	NN05103610	RU46				
R674			CHIP 10kΩ ±5% 1/16W	NN05103610	RU47			CHIP 1kΩ ±5% 1/16W	NN05102610
RD01			CHIP 22kΩ ±5% 1/16W	NN05223610	RU48			CHIP 47kΩ ±5% 1/16W	NN05473610
RD02			CHIP 22kΩ ±5% 1/16W	NN05223610	RU49			CHIP 47kΩ ±5% 1/16W	NN05473610
RD03			CHIP 22kΩ ±5% 1/16W	NN05223610	RU50			CHIP 10kΩ ±5% 1/16W	NN05103610
RK01			CHIP 6.8kΩ ±5% 1/16W	NN05682610					
RK02			CHIP 6.8kΩ ±5% 1/16W	NN05682610	DU01			P604-SEMICONDUCTORS CHIP DIODE	HZ21005000
RK03			CHIP 4.7kΩ ±5% 1/16W	NN05472610				1SS301 DAN202U UMT	
RK04			CHIP 4.7kΩ ±5% 1/16W	NN05472610	Q600			IC CS494001-CQ AUDIO DECODER	HC10014880
RK05			CHIP 5.6kΩ ±5% 1/16W	NN05562610	Q601			IC 4M FLASH FPT-48P-M19	*HS03AKXOR
RK06			CHIP 5.6kΩ ±5% 1/16W	NN05562610	Q603			IC TC74VHCT32AFT	HC010505K0
RK07					⚠ Q680			IC TA48025F(TE16L N)	HC36J25050
RK10			CHIP 4.7kΩ ±5% 1/16W	NN05472610	⚠ Q681			IC TA48033F(TE16L N)	HC36J33050
RK11					QD01			IC CS4382 24BIT DR=114 8CH-DAC	HC10012880
RK14			CHIP 150Ω ±5% 1/16W	NN05151610	QK01			IC NJM2115M	HC10172090
					QK02			IC NJM2115M	HC10172090
					QK03			CHIP TRS. 2SC4213	HX342132A0
					QK04			CHIP TRS. 2SC4213	HX342132A0
					QK05			DIG.TRS. RN2303 PNPX1 22k+22k	BA10013050
					QK30			IC CS5361-KSR A/D CONVERTER	HC10015880

NOTE : *nsp* PART IS LISTED FOR REFERENCE ONLY, MARANTZ WILL NOT SUPPLY THESE PARTS.

PS7300

POS. NO	VERS. COLOR	PART NO. (FOR EUR)	DESCRIPTION	PART NO. (MJI)	POS. NO	VERS. COLOR	PART NO. (FOR EUR)	DESCRIPTION	PART NO. (MJI)
QR01			IC LC89057W-VF4-E DAIO	HC10418030	R805			METAL 2.2kΩ ±5% 1W	NK05222010
QR02			IC TC74VHCT08AFT EL X4 2INPUT AND	HC007505K0	R811			ERG1SJ-E	
QR03			IC TC74VHCT08AFT EL X4 2INPUT AND	HC007505K0	R812			METAL 1Ω ±5% 1/2W	NK05010120
QR04			IC TC74HCT7007AF SOP	HC800705Q0	RP91			METAL 1Ω ±5% 1/2W	NK05010120
QU01			IC H8S/2398F-ZTAT	HC60028010	RP92			METAL 330Ω ±5% 1W	NK05331010
QU02			IC ATMEL AT24C08 8PIN SOIC	HC10191990				METAL 330Ω ±5% 1W	NK05331010
QU03			IC HIN202ECB 16LEAD WIDE BODY	HC10204990	R****			P804-RESISTORS (COMMON) CARBON FILM FIXED RES. ±5% 1/6W : RN51-RN59 RN71-RN80 RN95 RN96	
QU04			IC S-80145ALMC-JA6-T2 50MSEC	HC10099540				P804-SEMICONDUCTORS DIODE 6GBU04 6A 400V	HE20002990
QU06			DIG.TR.S. RN2303 PNPX1 22k+22k	BA10013050	▲ D801			DIODE 1D3 1A 200V	HD20002710
L600			P604-MISCELLANEOUS FERRITE CORE BK1608HM102-T	FC90020120	▲ D802			ZENER DIODE 6.8V	HD30681000
LU02			FERRIT BEADS		▲ D814			ZENER DIODE MTZ J 30V	HD33001000
LU17			FERRITE CORE	FC90020210	D816			DIODE 1D3 1A 200V	HD20002710
LU18			MLB-1608-1000A-N2		D817			DIODE 1D3 1A 200V	HD20002710
LU19			EMI FILTER NFM41R10C223T1/B1	FM12223030	DN51			DIODE 1D3 1A 200V	HD20002710
LU20			EMI FILTER NFM41R10C223T1/B1	FM12223030	DN55			DIODE 1D3 1A 200V	HD20002710
LU38			FERRITE CORE	FC90020210	▲ DP91			IC NJM7812FA +12V 1A	HC3891209F
LU40			MLB-1608-1000A-N2		▲ Q801			IC NJM7912FA -12V 1A	HC3991209F
LU44			FERRITE CORE	FC90020210	▲ Q802			IC NJM7805FA +5V	HC3890509F
LU46			CORE MLB-1608-1000A-N2		▲ Q803			IC NJM7805FA +5V	HC3890509F
LU67			FERRITE CORE	FC90020210	▲ Q804			TR.S. 2SA1048 Y OR GR	HT110482B0
LU69			CORE MLB-1608-1000A-N2		QN51			DIG.TR.S.	BA20001000
LU78			FERRITE CORE	FC90020210	QN55			DTC114ES UN4211 10k 10k	HT324582B0
XR51			CRYSTAL SMD-49 12.288MHz	JX12006350	QN56			TR.S. 2SC2458 Y OR GR	HT324582B0
XU01			SERAMIC VIB. CSTCW-X 20.0MHz	FQ02005060	QN59			TR.S. 2SA1048 Y OR GR	HT110482B0
			P804-POWER SUPPLY SPK OUTS		QN60			DIG.TR.S.	BA20001000
			CIRCUIT BOARD		QN61			DTC114ES UN4211 10k 10k	HT110482B0
			P804-CAPACITORS		QN62			TR.S. 2SA1048 Y OR GR	HT110482B0
▲ C801			ELECT. CAP 35XL60 AUDIO ALH6	OB15906360	QP91			TR.S. 2SA1048 Y OR GR	HT110482B0
▲ C802			BLACK 8724		QP92			P804-MISCELLANEOUS TERMINAL SPKR FL(A) FR(A)	YT01040790
▲ C803			ELECT. CAP 35XL60 AUDIO ALH6	OB15906360	J171			TERMINAL SPKR FL(B) FR(B)	YT01040790
▲ C804			BLACK 8724		J172			TERMINAL SPKR SR CENTER	YT01040790
C805			ELECT. 2200µF M 35V RA-2	OA22803520	J173			TERMINAL SPKR SB SL	YT01040790
C806			ELECT. 2200µF M 35V RA-2	OA22803520	J174			RELAY SPKR OUT	LY20240490
▲ C815			ELECT. 100µF M 16V RA-2	OA10701620	LN51			RELAY AVSS OEG PCLH 10A	LY20240520
▲ C816			ELECT. 100µF M 16V RA-2	OA10701620	LN54			RELAY OEG OSA-SS-224DM3 HP	LY20240510
C817			ELECT. 100µF M 16V RA-2	OA10701620	LN99			OUT	
C818			ELECT. 100µF M 16V RA-2	OA10701620	LP91			P854-BACK UP TRANS AC OUTLET FUSE CIRCUIT BOARD	
C820			ELECT. 100µF M 63V RA-2	OA10706320				P854-CAPACITORS CER. DE1607-1F 103M-KH	DK17103910
CN56			ELECT. 4.7µF M 16V RA-2	OA47601620				ELECT. 3300µF 25V RA2	OA33802520
			P804 CAPACITORS (COMMON)		▲ C851			ELECT. 100µF M 16V RA-2	OA10701620
			PLASTIC FILM CAPACITOR		▲ C852			ELECT. 4.7µF 50V M RA-2	OA47505020
			±5% 50V : C171-C174 C271-C274		C855			P854-RESISTORS (COMMON) CARBON FILM FIXED RES. ±5% 1/6W : R852-855	
			C371-C374		▲ C857			P854-SEMICONDUCTORS DIODE 1D3 1A 200V	HD20002710
R171			P804-RESISTORS		R****			ZENER DIODE 8.2V	HD30821000
R172			METAL 10Ω ±5% 1W	NK05100010					
R271			METAL 10Ω ±5% 1W	NK05100010	▲ D851				
R272			METAL 10Ω ±5% 1W	NK05100010	▲ D856				
R371			METAL 10Ω ±5% 1W	NK05100010	D859				
R372			METAL 10Ω ±5% 1W	NK05100010					
R802			METAL 2.2kΩ ±5% 1W	NK05222010					
			ERG1SJ-E						

NOTE : "nsp" PART IS LISTED FOR REFERENCE ONLY, MARANTZ WILL NOT SUPPLY THESE PARTS.

PS7300

POS. NO	VERS. COLOR	PART NO. (FOR EUR)	DESCRIPTION	PART NO. (MJI)	POS. NO	VERS. COLOR	PART NO. (FOR EUR)	DESCRIPTION	PART NO. (MJI)
▲ D860 D862			DIODE 1D3 1A 200V DIODE 1SS176 MA165 1SS254 30V 0.1A	HD20002710 HD20002000	R***		PC54-SURR.ENCODER CIRCUIT BOARD PC54-RESISTORS (COMMON) CARBON FILM FIXED RES. ±5% 1/6W : RC50-RC57 RC58		
▲ Q851 Q852 Q853 Q854			IC NJM7805FA +5V IC RESET IC (4.2V) DIG.TR.S. DTC114ES UN4211 10k 10k TRS. 2SA1048 Y OR GR	HC3890509F HC10011980 BA20001000 HT110482B0	JP70		PC74-AUX OPT CIRCUIT BOARD OPT. CONNECTOR TORX179L	YJ15000230	
▲ F851 ▲ J860			FUSE 10A 250V UL CSA MITI GMB JACK 2P AC OUTLET (CCT1304-0212)	FS11000530 YJ04002040			PD04-DIG-IN/OUT PREOUT CIRCUIT BOARD PD04-CAPACITORS		
▲ L851 ▲ T851			RELAY TV-8 OEG SDT-S-109DMR POWER TRANSF. BACKUP AC100V	LY10090010 TS12813030	C980 C981 C982 C983 CA02 CA06 CA17		ELECT. 100µF M 16V RA-2 ELECT. 100µF M 16V RA-2 ELECT. 100µF M 16V RA-2 ELECT. 47µF M 25V RA-2 ELECT. 47µF M 25V RA-2 ELECT. 47µF M 25V RA-2	OA10701620 OA10701620 OA10701620 OA47602520 OA47602520 OA47602520	
▲ J871			P874-AC INLET CIRCUIT BOARD JACK 2P AC INLET PW1910-H	YJ04002440			PD04 CAPACITORS (COMMON) HIGH DIELECTRIC CONSTANT CER. CAPACITOR ±10% 50V : C971 C972-C978 CA14 PLASTIC FILM CAPACITOR ±5% 50V : CA07-CA09 CA15		
▲ C881			P884-AC CIRCUIT BOARD CER. DE091 B 471 -KX 250V	DK17471520	C***				
▲ S881			PUSH SWITCH AC POWER ESB92S17B	SP01013800	C***				
			PC04-FRONT CIRCUIT BOARD PC04-CAPACITORS ELECT. 100µF M 50V RA-2	OA10705020	R***		PD04-RESISTORS (COMMON) CARBON FILM FIXED RES. ±5% 1/6W : RA01-RA03 RA05-RA07 RA09-RA11 RA13-RA15 RA17 RA52-RA57 RA60 RA61 RA64-RA73		
CC18			PC04-RESISTORS COMPO. RKC13BS473J ±5% P1.8 COMPO. RKC13BS473J ±5% P1.8 COMPO. RKC13BS473J ±5% P1.8 COMPO. RKC13BS103J ±5% P1.8	BW05473230 BW05473230 BW05473230 BW05103330			PD04-SEMICONDUCTORS DIODE 1SS176 MA165 1SS254 30V 0.1A DIODE 1SS176 MA165 1SS254 30V 0.1A DIODE 1SS176 MA165 1SS254 30V 0.1A	HD20002000 HD20002000 HD20002000	
			PC04-RESISTORS (COMMON) CARBON FILM FIXED RES. ±5% 1/6W : RC01-RC04 RC09-RC32 RC36-RC40 RP01-RP06 RP12 RP13		DA01 DA06 DA50 DA51				
			PC04-SEMICONDUCTORS ZENER DIODE MTZ J 3.3V	HD30331000	QA01 QA02		IC LC74HCU04 IC 74HC08 2-INPUT AND GATE H-CMOS	HC700400U0 HC700800B0	
			IC NJU3430FG1 TRS. 2SC2458 2SC1740S 2SC3199 ETC. PHOTO UNIT RPM6936-V4 IR SENSOR	HC10220090 HT30001000 HW10004210	QA50 QA51 QA52		TRS. 2SA950 GR R TRS. 2SA950 GR R DIG.TR.S. DTC114ES UN4211 10k 10k DIG.TR.S.	HT109501A0 HT109501A0 BA20001000 BA20001000	
			DIG.TR.S. DTA114ES UN4111 10k 10k	BA10001000	QA53 QA54		DTC114ES UN4211 10k 10k DIG.TR.S. DTA114ES UN4111 10k 10k DIG.TR.S.	BA10001000 BA10001000	
QP01 QP02			IC NJM4558D-D IC TC74VHC08F	HC10008090 HC10452050	QA55		DTA114ES UN4111 10k 10k DIG.TR.S. DTA114ES UN4111 10k 10k DIG.TR.S.	BA10001000 BA10001000	
			PC04-MISCELLANEOUS TERMINAL YKF51-5584 1P Y/C TOP TERMINAL YKC21-5891 1L3P Y/W/R TOP	YT02011730 YT02030740	QA56 QA57		DTC114ES UN4211 10k 10k DIG.TR.S. DTA114ES UN4111 10k 10k DIG.TR.S.	BA20001000 BA10001000	
			PUSH SWITCH SKQNAE H/5MM 160 GF ALPS ROTARY SWITCH ROTARY ENCODER C12E 24PULSE DISPLAY UNIT CM2071C NORITAKE	SP01013310 SR02010090 HQ31606920	QA58 QA59 QA60 QA61 QA62		PHOTO UNIT PC-817 PHOTO CUPLER 1PAIR DIG.TR.S. DTA114ES UN4111 10k 10k DIG.TR.S. DTC114ES UN4211 10k 10k DIG.TR.S. DTA114ES UN4111 10k 10k DIG.TR.S. DTC114ES UN4211 10k 10k DIG.TR.S.	HW10006320 BA10001000 BA20001000 BA10001000 BA10001000 BA20001000	
VC01									

NOTE : "nsp" PART IS LISTED FOR REFERENCE ONLY, MARANTZ WILL NOT SUPPLY THESE PARTS.

PS7300

POS. NO	VERS. COLOR	PART NO. (FOR EUR)	DESCRIPTION	PART NO. (MJI)	POS. NO	VERS. COLOR	PART NO. (FOR EUR)	DESCRIPTION	PART NO. (MJI)
QA63			DIG.TR.S.	BA10001000	JS71			TERMINAL YKC21-3503 1L2P W/R	YT02021600
QT02			DTA114ES UN4111 10k 10k	BA20001000	JU11			FG NI	YP11000220
QT04			DIG.TR.S.	BA10001000				PLUG DZ101A1-B2 RS232C	
			DTA114ES UN4111 10k 10k					PL04-CVBS Y/C	
								CIRCUIT BOARD	
								PL04-CAPACITORS	
J970			TERMINAL YKC21-3925 2L4P FG	YT02041350	CF01			ELECT. 10µF M 50V RA-2	OA10605020
J971			BK NI		}				
J971			TERMINAL YKC21-3925 2L4P FG	YT02041350	CF04				
			BK NI		CF05			ELECT. 470µF M 6.3V RA-2	OA47700620
JA01			OPT. CONNECTOR TORX179L	YJ15000230	CF08			ELECT. 100µF M 10V RA-2	OA10701020
			TOSLINK RECEIVER		CF10			ELECT. 100µF M 10V RA-2	OA10701020
JA02			OPT. CONNECTOR TORX179L	YJ15000230	CF14			ELECT. 10µF M 50V RA-2	OA10605020
			TOSLINK RECEIVER		CF15			ELECT. 10µF M 50V RA-2	OA10605020
JA03			OPT. CONNECTOR TORX179L	YJ15000230	CF16			ELECT. 10µF M 50V RA-2	OA10605020
			TOSLINK RECEIVER		CF18			ELECT. 100µF M 10V RA-2	OA10701020
JA04			TERMINAL YKC21-4272 1L3P FS	YT02030750	CL01			ELECT. 10µF M 50V RA-2	OA10605020
			BK NI		CL03			ELECT. 10µF M 50V RA-2	OA10605020
JA06			TERMINAL 14X14 RA 1L1P BLK NI	YT02010780	CL05			ELECT. 10µF M 50V RA-2	OA10605020
			FLM-GND		CL07			ELECT. 10µF M 50V RA-2	OA10605020
JA07			OPT. CONNECTOR TOTX179L	YJ15000220	CL09			ELECT. 470µF M 6.3V RA-2	OA47700620
			TOSLINK TRANSCEIVER		CL11			ELECT. 470µF M 6.3V RA-2	OA47700620
JA50			JACK LGA6502-0150 3.5MM MINI	YJ01004750	CL13			ELECT. 470µF M 6.3V RA-2	OA47700620
JA51			TERMINAL 4P RCA ORGX2 GR NX2	YT02041260	CL16			ELECT. 100µF M 10V RA-2	OA10701020
			NI DUAL-GND		CL18			ELECT. 100µF M 10V RA-2	OA10701020
LA01			PULSE TRANSF	TP41042030	CL19			ELECT. 10µF M 50V RA-2	OA10605020
			(TPS247MN-0386AN)		CL21			ELECT. 10µF M 50V RA-2	OA10605020
SA50			PUSH SWITCH	SP02022320	CL23			ELECT. 100µF M 10V RA-2	OA10701020
			(SPUJ191000) W/KNOB		CL24			ELECT. 10µF M 50V RA-2	OA10605020
					CL25			ELECT. 4.7µF M 50V RA-2	OA47505020
					CL26			ELECT. 1µF M 50V RA-2	OA10505020
			PF04-COMPONENT CIRCUIT BOARD		CL28			ELECT. 1µF M 50V RA-2	OA10505020
			PF04-CAPACITORS		CL31			ELECT. 100µF M 10V RA-2	OA10701020
CF51			ELECT. 47µF M 10V RA-2	OA47601020	CL37			ELECT. 10µF M 50V RA-2	OA10605020
CF53			ELECT. 47µF M 10V RA-2	OA47601020	CL41			ELECT. 10µF M 50V RA-2	OA10605020
CF55			ELECT. 47µF M 10V RA-2	OA47601020	CL42			ELECT. 10µF M 50V RA-2	OA10605020
CF57			ELECT. 47µF M 10V RA-2	OA47601020	CL44			ELECT. 100µF M 10V RA-2	OA10701020
CF59			ELECT. 47µF M 10V RA-2	OA47601020	CL48			ELECT. 10µF M 50V RA-2	OA10605020
CF61			ELECT. 47µF M 10V RA-2	OA47601020	CL50			ELECT. 100µF M 10V RA-2	OA10701020
CF63			ELECT. 470µF M 6.3V RA-2	OA47700620	CL53			ELECT. 10µF M 50V RA-2	OA10605020
CF66			ELECT. 470µF M 6.3V RA-2	OA47700620	CL80			ELECT. 10µF M 50V RA-2	OA10605020
CF69			ELECT. 470µF M 6.3V RA-2	OA47700620	CL82			ELECT. 2.2µF M 50V RA-2	OA22505020
CF73			ELECT. 47µF M 10V RA-2	OA47601020	CL83			ELECT. 10µF M 50V RA-2	OA10605020
CF74			ELECT. 47µF M 10V RA-2	OA47601020	CX01			ELECT. 10µF M 50V RA-2	OA10605020
CF76			ELECT. 47µF M 10V RA-2	OA47601020	CX02			ELECT. 10µF M 50V RA-2	OA10605020
CF78			ELECT. 47µF M 10V RA-2	OA47601020	CX04			ELECT. 10µF M 50V RA-2	OA10605020
CF86			ELECT. 100µF M 10V RA-2	OA10701020	CX05			ELECT. 10µF M 50V RA-2	OA10605020
CF87			ELECT. 100µF M 10V RA-2	OA10701020	CX07			ELECT. 10µF M 50V RA-2	OA10605020
CF88			ELECT. 10µF M 50V RA-2	OA10605020	CX08			ELECT. 10µF M 50V RA-2	OA10605020
CF90			ELECT. 10µF M 50V RA-2	OA10605020	CX10			ELECT. 10µF M 50V RA-2	OA10605020
					CX11			ELECT. 10µF M 50V RA-2	OA10605020
			PF04-RESISTORS (COMMON)		CX13			ELECT. 470µF M 6.3V RA-2	OA47700620
			CARBON FILM FIXED RES.		CX14			ELECT. 10µF M 50V RA-2	OA10605020
			±5% 1/6W : RF66 RF67		CX17			ELECT. 470µF M 6.3V RA-2	OA47700620
			RS71-RF04:[F]		CX18			ELECT. 10µF M 50V RA-2	OA10605020
					CX21			ELECT. 470µF M 6.3V RA-2	OA47700620
			PF04-SEMICONDUCTORS		CX22			ELECT. 10µF M 50V RA-2	OA10605020
QF51			IC NJM2584D VIDEO SEL 50MHz	HC10229090	CX26			ELECT. 100µF M 10V RA-2	OA10701020
QF52			IC NJM2581D 3CH VIDEO AMP 50MHz	HC10230090	CX28			ELECT. 100µF M 10V RA-2	OA10701020
					CX31			ELECT. 100µF M 10V RA-2	OA10701020
JF51			TERMINAL YKC21-4310 1L3P	YT02030720	CX33			ELECT. 100µF M 10V RA-2	OA10701020
			G/B/R FG NI		CX35			ELECT. 10µF M 50V RA-2	OA10605020
JF52			TERMINAL YKC21-4310 1L3P	YT02030720	CX36			ELECT. 10µF M 50V RA-2	OA10605020
			G/B/R FG NI		CX39			ELECT. 100µF M 10V RA-2	OA10701020
JF53			TERMINAL YKC21-4075 1L3P	YT02030710	CX40			ELECT. 10µF M 50V RA-2	OA10605020
			G/B/R FS NI		CX41			ELECT. 10µF M 50V RA-2	OA10605020
					CX44			ELECT. 100µF M 10V RA-2	OA10701020
					CX47			ELECT. 10µF M 50V RA-2	OA10605020

NOTE : "nsp" PART IS LISTED FOR REFERENCE ONLY, MARANTZ WILL NOT SUPPLY THESE PARTS.

PS7300

POS. NO	VERS. COLOR	PART NO. (FOR EUR)	DESCRIPTION	PART NO. (MJI)	POS. NO	VERS. COLOR	PART NO. (FOR EUR)	DESCRIPTION	PART NO. (MJI)
CX48			ELECT. 10µF M 50V RA-2	OA10605020	JL03			TERMINAL YKC21-4030 1L2P YEL FS NI	YT02021750
C***			PL04-CAPACITORS (COMMON) HIGH DIELECTRIC CONSTANT CER. CAPACITOR ±10% 50V : CL27 CX46 CX49		JX01			TERMINAL YKF51-5514 3P S-TERMINAL NI	YT02030350
R***			PL04-RESISTORS (COMMON) CARBON FILM FIXED RES. ±5% 1/6W : RF06-RF10 RL13-RL19 RL23-RL26RL29-RL37 RL39-RL41 RL44 RL80-RL83 RX21-RX23 RX25-RX32		JX02			TERMINAL YKF51-5510 2P S-TERMINAL NI	YT02021320
			PL04-SEMICONDUCTORS		JX03			TERMINAL YKF51-5510 2P S-TERMINAL NI	YT02021320
DL01			DIODE 1D3 1A 200V	HD20002710	LL01			CHOKE COIL 33uH LAL02TA330J	LC13333800
DL80			DIODE	HD20002000	LL02			EMI FILTER DSS306-91-F-223Z	FM12223010
DL81			1SS176 MA165 1SS254 30V 0.1A	HD20002000	XL01			CRYSTAL AT49/14.31818MHz	JX14001260
DX01			DIODE	HD20002000	JP99			PP94-HEAD PHONES OUT CIRCUIT BOARD JACK HLJ2307-01-3160 HEAD PHONES OUT	YJ01004240
DX04			1SS176 MA165 1SS254 30V 0.1A	HD20002000				PS04-AUDIO FUNCTION/VOLUME CIRCUIT BOARD	
QF01			IC NJM2595D	HC10227090	CE09			PS04-CAPACITORS ELECT. 22µF M 50V RA-2	OA22605020
QF02			5IN 3OUT VIDEO SEL	HC10119090	CE10			ELECT. 22µF M 50V RA-2	OA22605020
QF03			IC NJM2244D	HC709449B0	CE11			ELECT. 22µF M 50V RA-2	OA22605020
QL01			3IN 1OUT VIDEO SEL	HC10227090	CE12			ELECT. 22µF M 50V RA-2	OA22605020
QL02			IC 74HC4094 16PIN DIP	HC10228090	CE13			ELECT. 10µF M 50V RA-2	OA10605020
QL03			IC NJM2595D	HC10377030	CE14			ELECT. 10µF M 50V RA-2	OA10605020
QL04			5IN 3OUT VIDEO SEL	HC10119090	CE19			ELECT. 47µF M 25V RA-2	OA47602520
QL05			IC NJM2535D	HT30001000	CE20			ELECT. 47µF M 25V RA-2	OA47602520
QL06			3IN 1OUT VIDEO SEL	HT30001000	CE59			ELECT. 22µF M 50V RA-2	OA22605020
QL07			IC LC74781 OSD	BA10001000	CE60			ELECT. 22µF M 50V RA-2	OA22605020
QL11			IC NJM2244D	BA20001000	CE61			ELECT. 22µF M 50V RA-2	OA22605020
QL12			3IN 1OUT VIDEO SEL	HT30001000	CE62			ELECT. 22µF M 50V RA-2	OA22605020
QL13			IC 74HC4094 16PIN DIP	HT30001000	CE63			ELECT. 10µF M 50V RA-2	OA10605020
QL14			TRS.	CG09	CE64			ELECT. 10µF M 50V RA-2	OA10605020
QL15			2SC2458 2SC1740S 2SC3199 ETC. TRS.	CG10	CE69			ELECT. 47µF M 25V RA-2	OA47602520
▲ QL16			2SC2458 2SC1740S 2SC3199 ETC. TRS.	CG11	CE70			ELECT. 47µF M 25V RA-2	OA47602520
QL80			IC NJM7905FA	CG12	CE81			ELECT. 47µF M 25V RA-2	OA47602520
QL81			TRS. A1048 A933S A1267 ETC. DIG. TRS.	CG13	CE83			ELECT. 47µF M 25V RA-2	OA47602520
QX01			DTA114ES UN4111 10k 10k	CG14	CE85			ELECT. 47µF M 25V RA-2	OA47602520
QX02			DIG. TRS.	CG19	CE87			ELECT. 47µF M 25V RA-2	OA47602520
QX03			DTC114ES UN4211 10k 10k	CG20	CG09			ELECT. 22µF M 50V RA-2	OA22605020
QX04			TRS.	CG59	CG10			ELECT. 22µF M 50V RA-2	OA22605020
QX05			2SC2458 2SC1740S 2SC3199 ETC. TRS.	CG62	CG11			ELECT. 22µF M 50V RA-2	OA22605020
JL01			IC NJM2595D	CG63	CG12			ELECT. 22µF M 50V RA-2	OA22605020
JL02			5IN 3OUT VIDEO SEL	CG64	CG13			ELECT. 10µF M 50V RA-2	OA10605020
			IC NJM2595D	CG69	CG14			ELECT. 10µF M 50V RA-2	OA10605020
			5IN 3OUT VIDEO SEL	CG70	CG19			ELECT. 47µF M 25V RA-2	OA47602520
			IC NJM2264D	CH09	CG20			ELECT. 47µF M 25V RA-2	OA47602520
			3IN 1OUT VIDEO SEL	CH16	CG59			ELECT. 22µF M 50V RA-2	OA22605020
			IC NJM2244D	CJ09	CG62			ELECT. 10µF M 50V RA-2	OA10605020
			3IN 1OUT VIDEO SEL	CJ16	CG63			ELECT. 47µF M 25V RA-2	OA47602520
			TRS. A1048 A933S A1267 ETC.	CM01	CG64			ELECT. 47µF M 25V RA-2	OA47602520
			PL04-MISCELLANEOUS	CM02	CG69			ELECT. 47µF M 25V RA-2	OA47602520
			TERMINAL YKC21-3508 1L3P YEL FG NI	CM05	CG70			ELECT. 47µF M 25V RA-2	OA47602520
			TERMINAL YKC21-3508 1L3P YEL FG NI	CM06	CH09			FILM 470pF J M 50V	DF15471350
				CM31	CH16			FILM 470pF J M 50V	DF15471350
				CM32	CJ09				
				CM33	CJ16				
					CM01			ELECT. 10µF M 50V RA-2	OA10605020
					CM02			ELECT. 10µF M 50V RA-2	OA10605020
					CM05			ELECT. 10µF M 50V RA-2	OA10605020
					CM06			ELECT. 10µF M 50V RA-2	OA10605020
					CM31			ELECT. 22µF M 50V RA-2	OA22605020
					CM32			ELECT. 22µF M 50V RA-2	OA22605020
					CM33			ELECT. 10µF M 50V RA-2	OA10605020

NOTE : *nsp* PART IS LISTED FOR REFERENCE ONLY, MARANTZ WILL NOT SUPPLY THESE PARTS.

PS7300

POS. NO	VERS. COLOR	PART NO. (FOR EUR)	DESCRIPTION	PART NO. (MJI)	POS. NO	VERS. COLOR	PART NO. (FOR EUR)	DESCRIPTION	PART NO. (MJI)
CM34			ELECT. 10µF M 50V RA-2	OA10605020	DQ85			DIODE 1D3 1A 200V	HD20002710
CM39			ELECT. 47µF M 25V RA-2	OA47602520	DQ86			DIODE 1D3 1A 200V	HD20002710
CM40			ELECT. 47µF M 25V RA-2	OA47602520					
CQ03			ELECT. 10µF M 50V RA-2	OA10605020	QE03			IC NJM-2068-DD	HC10053090
CQ04			ELECT. 10µF M 50V RA-2	OA10605020	QE05				
CQ07			ELECT. 10µF M 50V RA-2	OA10605020	}			TRS. KTC2874 NPN	HT805501B0
CQ08			ELECT. 10µF M 50V RA-2	OA10605020	QE08				
CQ11			ELECT. 10µF M 50V RA-2	OA10605020	QE11			IC TC9499N	HC10467050
CQ12			ELECT. 10µF M 50V RA-2	OA10605020	QE12			IC TC9499N	HC10467050
CQ15			ELECT. 10µF M 50V RA-2	OA10605020	QE53			IC NJM-2068-DD	HC10053090
CQ16			ELECT. 10µF M 50V RA-2	OA10605020	QE55				
CQ19			ELECT. 10µF M 50V RA-2	OA10605020	}			TRS. KTC2874 NPN	HT805501B0
CQ20			ELECT. 10µF M 50V RA-2	OA10605020	QE58				
CQ23			ELECT. 10µF M 50V RA-2	OA10605020	QG03			IC NJM-2068-DD	HC10053090
CQ24			ELECT. 10µF M 50V RA-2	OA10605020	QG05				
CQ27			ELECT. 10µF M 50V RA-2	OA10605020	}			TRS. KTC2874 NPN	HT805501B0
CQ28			ELECT. 10µF M 50V RA-2	OA10605020	QG08				
CQ31			ELECT. 10µF M 50V RA-2	OA10605020	QG53			IC NJM-2068-DD	HC10053090
CQ32			ELECT. 10µF M 50V RA-2	OA10605020	QG55				
CQ73			ELECT. 100µF M 16V RA-2	OA10701620	}			TRS. KTC2874 NPN	HT805501B0
CQ74			ELECT. 100µF M 16V RA-2	OA10701620	QG58				
CQ76			ELECT. 100µF M 16V RA-2	OA10701620	QH01			IC NJM-2068-DD	HC10053090
CQ78			ELECT. 100µF M 16V RA-2	OA10701620	QH02			IC NJM-2068-DD	HC10053090
CQ89			ELECT. 100µF M 16V RA-2	OA10701620	QJ01			IC NJM-2068-DD	HC10053090
CQ90			ELECT. 100µF M 16V RA-2	OA10701620	QJ02			IC NJM-2068-DD	HC10053090
					QM01			IC NJM4558D-D	HC10008090
CS09			ELECT. 10µF M 50V RA-2	OA10605020	QM13			IC NJM-2068-DD	HC10053090
CS10			ELECT. 10µF M 50V RA-2	OA10605020	QM15				
CS15			ELECT. 10µF M 50V RA-2	OA10605020	}			TRS. KTC2874 NPN	HT805501B0
CS16			ELECT. 10µF M 50V RA-2	OA10605020	QM18				
CS23			ELECT. 10µF M 50V RA-2	OA10605020	QM21			DIG.TRS.	BA10002000
CS24			ELECT. 10µF M 50V RA-2	OA10605020				DTA144ES UN4113 47k 47k	
CS41			ELECT. 10µF M 50V RA-2	OA10605020	QM22			DIG.TRS.	BA20002000
CS42			ELECT. 10µF M 50V RA-2	OA10605020				DTC144ES UN4213 47k 47k	
CS51			ELECT. 10µF M 50V RA-2	OA10605020	QM23			DIG.TRS.	BA10002000
CS52			ELECT. 10µF M 50V RA-2	OA10605020				DTA144ES UN4113 47k 47k	
CS55					QM24			DIG.TRS.	BA20002000
}								DTC144ES UN4213 47k 47k	
CS58			ELECT. 10µF M 50V RA-2	OA10605020	QM25			DIG.TRS.	BA10002000
CS61			ELECT. 10µF M 50V RA-2	OA10605020				DTA144ES UN4113 47k 47k	
CS62			ELECT. 10µF M 50V RA-2	OA10605020	QM26			DIG.TRS.	BA20002000
								DTC144ES UN4213 47k 47k	
			PS04-CAPACITORS (COMMON)		QM27			DIG.TRS.	BA10002000
			PLASTIC FILM CAPACITOR					DTA144ES UN4113 47k 47k	
			±5% 50V : CH01-HC08 CJ01-CJ08		QM28			DIG.TRS.	BA20002000
			PS04-RESISTORS (COMMON)					DTC144ES UN4213 47k 47k	
			CARBON FILM FIXED RES.		QM29			DIG.TRS.	BA10002000
			±5% 1/6W : RE09-RE12 RE15 RE16					DTA144ES UN4113 47k 47k	
			RE19-RE33 RE44 RE45 RE59-RE62		QM31			DIG.TRS.	BA10002000
			RE65 RE66 RE69-RE83					DTA144ES UN4113 47k 47k	
			RG09-RG12 RG15 RG16		QM32			DIG.TRS.	BA20002000
			RG19-RG33 RG59-RG62					DTC144ES UN4213 47k 47k	
			RG65 RG66 RG69-RG84		QM33			DIG.TRS.	BA10002000
			RH01-RH32 RJ01-RJ32					DTA144ES UN4113 47k 47k	
			RM01-RM04 RM31-RM34		QM44			DIG.TRS.	BA20002000
			RM37-RM51 RQ01-RQ04					DTC144ES UN4213 47k 47k	
			RQ07-RQ12 RQ15-RQ20		QM45			DIG.TRS.	BA20002000
			RQ23-RQ32 RS01-RS48					DTC144ES UN4213 47k 47k	
			RS51-RS58 RS61-RS68		QQ01				
					}			IC NJM4558D-D	HC10008090
			PS04-SEMICONDUCTORS		QQ04				
DM21					▲ QQ61			IC NJM78M06FA	HC3850609F
}					▲ QQ62			IC NJM79M06FA	HC3950609F
DM25			DIODE	HD20002000	QS01			IC TC9273N-013	HC10468050
DM27			1S176 MA165 1S254 30V 0.1A	HD20002000	QS02			IC TC9273N-013	HC10468050
					QS03			IC TC9164AN	HC10470050
					QS04			IC TC9162AN	HC10469050
DQ81			DIODE	HD20002000	QS05			IC NJM4558D-D	HC10008090
}					QS06			IC NJM4558D-D	HC10008090
DQ84			1S176 MA165 1S254 30V 0.1A						

NOTE : "nsp" PART IS LISTED FOR REFERENCE ONLY, MARANTZ WILL NOT SUPPLY THESE PARTS.

PS7300

POS. NO	VERS. COLOR	PART NO. (FOR EUR)	DESCRIPTION	PART NO. (MJI)
JQ01			PS04-MISCELLANEOUS TERMINAL YKC21-3925 2L4P FG BK NI	YT02041350
JQ02			TERMINAL YKC21-3925 2L4P FG BK NI	YT02041350
JS01 {			TERMINAL	YT02060660
JS04 WE99			YKC21-3796 2L6P FG W/R NI CONNECTIVE CORD SIN-SIN UL1430 AWG20 L=6CM	YE01000630

NOTE : *nsp* PART IS LISTED FOR REFERENCE ONLY, MARANTZ WILL NOT SUPPLY THESE PARTS.