

Service Manual

SR7400 /K1G/L1G/N1B/U1B
/N1S/S1G

AV Surround Receiver

PS7400 /F1N
AV Surround Amplifier

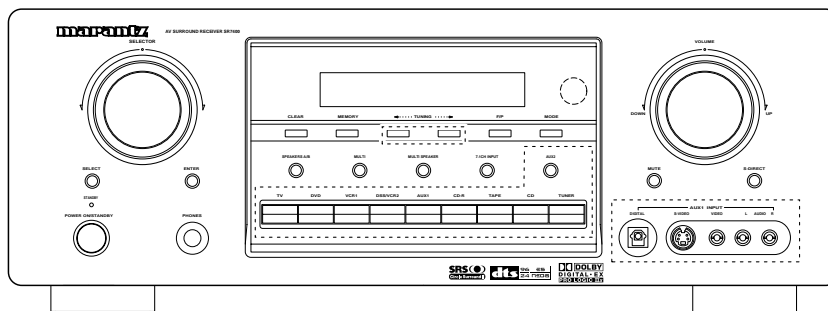

PS7400
SR7400

TABLE OF CONTENTS

SECTION	PAGE
1. TECHNICAL SPECIFICATIONS	1
2. TECHNICAL DESCRIPTION	4
3. WIRING DIAGRAM	7
4. BLOCK DIAGRAM	9
5. SCHEMATIC DIAGRAM	11
6. PARTS LOCATION	29
7. IC DATA	42
8. EXPLODED VIEW AND PARTS LIST	53
9. POWER AMPLIFIER ADJUSTMENT	57
10. SERVICE MODE	58
11. SYSTEM ERROR	60
12. UPDATE FIRMWARE	61
13. ELECTRICAL PARTS LIST	63

Please use this service manual with referring to the user guide (D.F.U.) without fail.
修理の際は、必ず取扱説明書を準備し操作方法を確認の上作業を行ってください。

marantz®

SR7400 / PS7400

MARANTZ DESIGN AND SERVICE

Using superior design and selected high grade components, **MARANTZ** company has created the ultimate in stereo sound. Only original **MARANTZ** parts can insure that your **MARANTZ** product will continue to perform to the specifications for which it is famous.

Parts for your **MARANTZ** equipment are generally available to our National Marantz Subsidiary or Agent.

ORDERING PARTS :

Parts can be ordered either by mail or by Fax.. In both cases, the correct part number has to be specified.

The following information must be supplied to eliminate delays in processing your order :

1. Complete address
2. Complete part numbers and quantities required
3. Description of parts
4. Model number for which part is required
5. Way of shipment
6. Signature : any order form or Fax. must be signed, otherwise such part order will be considered as null and void.

USA

MARANTZ AMERICA, INC
1100 MAPLEWOOD DRIVE
ITASCA, IL. 60143
USA
PHONE : 630 - 741 - 0300
FAX : 630 - 741 - 0301

EUROPE / TRADING

MARANTZ EUROPE B.V.
P. O. BOX 8744, BUILDING SILVERPOINT
BEEMDSTRAAT 11, 5653 MA EINDHOVEN
THE NETHERLANDS
PHONE : +31 - 40 - 2507844
FAX : +31 - 40 - 2507860

CANADA

LENBROOK INDUSTRIES LIMITED
633 GRANITE COURT,
PICKERING, ONTARIO L1W 3K1
CANADA
PHONE : 905 - 831 - 6333
FAX : 905 - 831 - 6936

PROFESSIONAL AMERICAS

SUPERSCOPE TECHNOLOGIES, INC.
MARANTZ PROFESSIONAL PRODUCTS
2640 WHITE OAK CIRCLE, SUITE A
AURORA, ILLINOIS 60504 USA
PHONE : 630 - 820 - 4800
FAX : 630 - 820 - 8103

PROFESSIONAL AUSTRALIA

TECHNICAL AUDIO GROUP PTY, LTD
43-53 Bridge Rd.,
STANMORE NSW 2048
AUSTRALIA
PHONE : +61 - (0)2 - 9519 - 0900
FAX : +61 - (0)2 - 9519 - 0600

PROFESSIONAL HONG KONG

Jolly ProAudio Broadcast Engineering Ltd.
UNIT 2, 10F, WAH HUNG CENTRE,
41 HUNG TO ROAD, KWUN TONG, KLN.,
HONG KONG
PHONE : 852 - 21913660
FAX : 852 - 21913990

AUSTRALIA

QualiFi Pty Ltd,
24 LIONEL ROAD,
MT. WAVERLEY VIC 3149
AUSTRALIA
PHONE : +61 - (0)3 - 9543 - 1522
FAX : +61 - (0)3 - 9543 - 3677

THAILAND

MRZ STANDARD CO., LTD
746 - 754 MAHACHAI ROAD.,
WANGBURAPAPIROM, PHRANAKORN,
BANGKOK, 10200 THAILAND
PHONE : +66 - 2 - 222 9181
FAX : +66 - 2 - 224 6795

SINGAPORE

WO KEE HONG DISTRIBUTION PTE LTD
130 JOO SENG ROAD
#03-02 OLIVINE BUILDING
SINGAPORE 368357
PHONE : +65 6858 5535 / +65 6381 8621
FAX : +65 6858 6078

NEW ZEALAND

WILDASH AUDIO SYSTEMS NZ
14 MALVERN ROAD MT ALBERT
AUCKLAND NEW ZEALAND
PHONE : +64 - 9 - 8451958
FAX : +64 - 9 - 8463554

TAIWAN

PAI- YUING CO., LTD.
6 TH FL NO, 148 SUNG KIANG ROAD,
TAIPEI, 10429, TAIWAN R.O.C.
PHONE : +886 - 2 - 25221304
FAX : +886 - 2 - 25630415

MALAYSIA

WO KEE HONG ELECTRONICS SDN. BHD.
2ND FLOOR BANGUNAN INFINITE CENTRE
LOT 1, JALAN 13/6, 46200 PETALING JAYA
SELANGOR DARUL EHSAN, MALAYSIA
PHONE : +60 - 3 - 7954 8088
FAX : +60 - 3 - 7954 7088

JAPAN Technical

MARANTZ JAPAN, INC.
35- 1, 7- CHOME, SAGAMIONO
SAGAMIHARA - SHI, KANAGAWA
JAPAN 228-8505
PHONE : +81 42 748 1013
FAX : +81 42 741 9190

日本マランツ株式会社

本社 〒228-8505
神奈川県相模原市相模大野7-35-1

KOREA

MK ENTERPRISES LTD.
ROOM 604/605, ELECTRO-OFFICETEL, 16-58,
3GA, HANGANG-RO, YONGSAN-KU, SEOUL
KOREA
PHONE : +822 - 3232 - 155
FAX : +822 - 3232 - 154

SHOCK, FIRE HAZARD SERVICE TEST :

CAUTION : After servicing this appliance and prior to returning to customer, measure the resistance between either primary AC cord connector pins (with unit NOT connected to AC mains and its Power switch ON), and the face or Front Panel of product and controls and chassis bottom.

Any resistance measurement less than 1 Megohms should cause unit to be repaired or corrected before AC power is applied, and verified before it is return to the user/customer.

Ref. UL Standard No. 1492.

In case of difficulties, do not hesitate to contact the Technical Department at above mentioned address.

1. TECHNICAL SPECIFICATIONS

FM TUNER SECTION [SR7400]

Frequency Range.....87.5 - 108.0 MHz
Usable Sensitivity IHF 1.8 μ V/16.4 dB
Signal to Noise Ratio..... Mono/Stereo 75/70 dB
Distortion.....Mono/Stereo 0.2/0.3 %
Stereo Separation 1 kHz 45 dB
Alternate Channel Selectivity \pm 300 kHz 60 dB
Image Rejection98 MHz 70 dB
Tuner Output Level 1 kHz, \pm 75 kHz Dev 800 mV

AM TUNER SECTION [SR7400]

Frequency Range.....531 - 1602 kHz [K/N/S]
..... 520 - 1710 kHz [L/U]
Signal to Noise Ratio..... 50 dB
Usable Sensitivity..... Loop 400 μ V
Distortion..... 1 kHz, 30 % Mod. 0.5 %
Selectivity \pm 20 kHz 70 dB

AUDIO SECTION

Power Output (20 Hz - 20 kHz/THD=0.08%)
Front L&R.....8 ohms 105 W / Ch
Center8 ohms 105 W / Ch
Surround L&R8 ohms 105 W / Ch
Surround Back8 ohms 105 W / Ch

Front L&R.....6 ohms 130 W / Ch
Center6 ohms 130 W / Ch
Surround L&R6 ohms 130 W / Ch
Surround Back6 ohms 130 W / Ch

Input Sensitivity/Impedance 168 mV/ 47 kohms
Signal to Noise Ratio
Analog Input / Source Direct..... 105 dB
Frequency Response
Analog Input / Source Direct..... 8 Hz - 100 kHz (\pm 3 dB)
Digital Input / 96 kHz PCM..... 8 Hz - 45 kHz (\pm 3 dB)

VIDEO

Television Format NTSC/PAL
Input Level/Impedance 1 Vp-p/75 ohms
Output Level/Impedance 1 Vp-p/75 ohms
Video Frequency Response5 Hz to 8 MHz (- 1 dB)
Video Frequency (Component)5 Hz to 80 MHz (- 1 dB)
S/N 60 dB

GENERAL

Power Requirement.....AC 100 V 50/60 Hz [F]
.....AC 220 V 50 Hz [K]
.....AC 110 V 60 Hz [L]
.....AC 230 V 50 Hz [N/S]
..... AC 120 V 60 Hz [U]
Power Consumption 540 W
Weight 14.0 kg (30.9 lbs)

ACCESSORIES

Remote Control Unit RC1400 1
AAA-size batteries..... 3
FM Antenna [SR7400]..... 1
FM Antenna Converter [SR7400]..... 1
AM Loop Antenna [SR7400] 1

The relation between the selected surround mode and the input signal

The surround mode is selected with the surround mode buttons on SR7400/PS7400 or the remote control unit. However, the sound you hear is subject to the relationship between the selected surround mode and input signal. That relationship is as follows;

SR7400

Surround Mode	Input Signal	Decoding	Output Channel					Front information display	
			L/R	C	SL SR	SBL SBR	SubW	Signal format indicators	Channel status
AUTO	Dolby Surr. EX	Dolby Digital EX	○	○	○	○	○	□□ DIGITAL	L, C, R, SL, SR, S, LFE
	Dolby D (5.1ch)	Dolby Digital 5.1	○	○	○	-	○	□□ DIGITAL	L, C, R, SL, SR, LFE
	Dolby D (2ch)	Dolby Digital 2.0	○	-	-	-	-	□□ DIGITAL	L, R
	Dolby D (2ch Surr)	Pro Logic IIx movie	○	○	○	○	-	□□ DIGITAL , □□ SURROUND	L, R, S
	DTS-ES	DTS-ES	○	○	○	○	○	dts , ES	L, C, R, SL, SR, S, LFE
	DTS 96/24	DTS 96/24	○	○	○	-	○	dts 96/24	L, C, R, SL, SR, LFE
	DTS (5.1ch)	DTS 5.1	○	○	○	-	○	dts	L, C, R, SL, SR, LFE
	PCM(Audio)	PCM (Stereo)	○	-	-	-	-	PCM	L, R
	PCM 96kHz	PCM (96kHz Stereo)	○	-	-	-	-	PCM	L, R
	Analog	Stereo	○	-	-	-	-	ANALOG	-
S-DIRECT	Dolby D Surr. EX	Dolby Digital EX	○	○	○	○	○	□□ DIGITAL	L, C, R, SL, SR, S, LFE
	Dolby D (5.1ch)	Dolby Digital 5.1	○	○	○	-	○	□□ DIGITAL	L, C, R, SL, SR, LFE
	Dolby D (2ch)	Dolby Digital 2.0	○	-	-	-	-	□□ DIGITAL	L, R
	Dolby D (2ch Surr)	Pro Logic IIx movie	○	○	○	○	-	□□ DIGITAL , □□ SURROUND	L, R, S
	DTS-ES	DTS-ES	○	○	○	○	○	dts , ES	L, C, R, SL, SR, S, LFE
	DTS 96/24	DTS 96/24	○	○	○	-	○	dts 96/24	L, C, R, SL, SR, LFE
	DTS (5.1ch)	DTS 5.1	○	○	○	-	○	dts	L, C, R, SL, SR, LFE
	PCM (Audio)	PCM (Stereo)	○	-	-	-	-	PCM	L, R
	PCM 96kHz	PCM (96kHz Stereo)	○	-	-	-	-	PCM	L, R
	Analog	Stereo	○	-	-	-	-	ANALOG	-
EX/ES	Dolby D Surr. EX	Dolby Digital EX	○	○	○	○	○	□□ DIGITAL	L, C, R, SL, SR, S, LFE
	Dolby D (5.1ch)	Dolby Digital EX	○	○	○	○	○	□□ DIGITAL	L, C, R, SL, SR, LFE
	DTS-ES	DTS-ES	○	○	○	○	○	dts , ES	L, C, R, SL, SR, S, LFE
	DTS(5.1ch)	DTS-ES	○	○	○	○	○	dts	L, C, R, SL, SR, LFE
DOLBY (PL IIx movie) (PL IIx music) (PL IIx game) (Pro Logic)	Dolby D Surr. EX	Dolby Digital 5.1	○	○	○	○	○	□□ DIGITAL	L, C, R, SL, SR, S, LFE
	Dolby D (5.1ch)	Dolby Digital 5.1	○	○	○	○	○	□□ DIGITAL	L, C, R, SL, SR, LFE
	Dolby D (2ch)	Pro Logic IIx	○	○	○	○	-	□□ DIGITAL	L, R
	Dolby D (2ch Surr)	Pro Logic IIx	○	○	○	○	-	□□ DIGITAL , □□ SURROUND	L, R, S
	PCM (Audio)	Pro Logic IIx	○	○	○	○	-	PCM	L, R
DTS (Neo:6 Cinema) (Neo:6 Music)	Analog	Pro Logic IIx	○	○	○	○	-	ANALOG	-
	DTS-ES	DTS 5.1	○	○	○	-	○	dts , ES	L, C, R, SL, SR, S, LFE
	DTS 96/24	DTS 96/24	○	○	○	-	○	dts 96/24	L, C, R, SL, SR, LFE
	DTS (5.1ch)	DTS 5.1	○	○	○	-	○	dts	L, C, R, SL, SR, LFE
	PCM (Audio)	Neo:6	○	○	○	○	-	PCM	L, R
	Analog	Neo:6	○	○	○	○	-	ANALOG	-
	Dolby D (2ch)	Neo:6	○	○	○	○	-	□□ DIGITAL	L, R
Dolby D (2ch Surr)	Neo:6	○	○	○	○	-	□□ DIGITAL , □□ SURROUND	L, R, S	
CS II Cinema CS II Music CS II Mono	PCM (Audio)	CS II	○	○	○	○	○	PCM	L, R
	Analog	CS II	○	○	○	○	○	ANALOG	-
	Dolby D (2ch)	CS II	○	○	○	○	○	□□ DIGITAL	L, R
STEREO	Dolby D (2ch Surr)	CS II	○	○	○	○	○	□□ DIGITAL , □□ SURROUND	L, R, S
	Dolby Surr. EX	Stereo	○	-	-	-	○	□□ DIGITAL	L, C, R, SL, SR, S, LFE
	Dolby D (5.1ch)	Stereo	○	-	-	-	○	□□ DIGITAL	L, C, R, SL, SR, LFE
	Dolby D (2ch)	Stereo	○	-	-	-	-	□□ DIGITAL	L, R
	Dolby D (2ch Surr)	Stereo	○	-	-	-	-	□□ DIGITAL , □□ SURROUND	L, R, S
	DTS-ES	Stereo	○	-	-	-	○	dts , ES	L, C, R, SL, SR, S, LFE
	DTS 96/24	Stereo	○	-	-	-	○	dts 96/24	L, C, R, SL, SR, LFE
	DTS (5.1ch)	Stereo	○	-	-	-	○	dts	L, C, R, SL, SR, LFE
	PCM (Audio)	Stereo	○	-	-	-	-	PCM	L, R
	PCM 96kHz	Stereo	○	-	-	-	-	PCM	L, R
Virtual	Analog	Stereo	○	-	-	-	-	ANALOG	-
	Dolby Surr. EX	Virtual	○	-	-	-	-	□□ DIGITAL	L, C, R, SL, SR, S, LFE
	Dolby D (5.1ch)	Virtual	○	-	-	-	-	□□ DIGITAL	L, C, R, SL, SR, LFE
	Dolby D (2ch)	Virtual	○	-	-	-	-	□□ DIGITAL	L, R
	Dolby D (2ch Surr)	Virtual	○	-	-	-	-	□□ DIGITAL , □□ SURROUND	L, R, S
	DTS-ES	Virtual	○	-	-	-	-	dts , ES	L, C, R, SL, SR, S, LFE
	DTS (5.1ch)	Virtual	○	-	-	-	-	dts	L, C, R, SL, SR, LFE
PCM (Audio)	Virtual	○	-	-	-	-	PCM	L, R	
Multi Ch. Stereo	Analog	Virtual	○	-	-	-	-	ANALOG	-
	Dolby Surr. EX	Dolby Digital EX	○	○	○	○	○	□□ DIGITAL	L, C, R, SL, SR, S, LFE
	Dolby D (5.1ch)	Dolby Digital 5.1	○	○	○	-	○	□□ DIGITAL	L, C, R, SL, SR, LFE
	Dolby D (2ch)	Multi Channel Stereo	○	○	○	○	-	□□ DIGITAL	L, R
	Dolby D (2ch Surr)	Multi Channel Stereo	○	○	○	○	-	□□ DIGITAL , □□ SURROUND	L, R, S
	DTS-ES	DTS-ES	○	○	○	○	○	dts , ES	L, C, R, SL, SR, S, LFE
	DTS (5.1ch)	DTS 5.1	○	○	○	-	○	dts	L, C, R, SL, SR, LFE
PCM (Audio)	Multi Channel Stereo	○	○	○	○	-	PCM	L, R	
Analog	Multi Channel Stereo	○	○	○	○	-	ANALOG	-	

Note:

- Dolby Digital (2 ch: Lt/Rt): signal with Dolby Surround flag Speakers are full set.
- No sound outputs from the surround speaker, center speaker and subwoofer if the DVD disc has no surround data.

Abbreviations

- L/R : Front speakers
- C : Center speaker
- SL/SR : Surround speakers
- SBL/SBR : Surround Back speakers
- SubW : Sub woofer speaker

PS7400

サラウンドモード	入力信号	再生	出力チャンネル					前面表示		
			L/R	C	SL SR	SBL SBR	SubW	信号フォーマット表示	プログラムチャンネル表示	
AUTO	Dolby Surr. EX	Dolby Digital EX	○	○	○	○	○	DD DIGITAL	L, C, R, SL, SR, S, LFE	
	Dolby D (5.1ch)	Dolby Digital 5.1	○	○	○	-	○	DD DIGITAL	L, C, R, SL, SR, LFE	
	Dolby D (2ch)	Dolby Digital 2.0	○	-	-	-	-	DD DIGITAL	L, R	
	Dolby D (2ch Surr)	Pro Logic IIx movie	○	○	○	○	*	DD DIGITAL, DD SURROUND	L, R, S	
	DTS-ES	DTS-ES	○	○	○	○	○	dis, ES	L, C, R, SL, SR, S, LFE	
	DTS 96/24	DTS 96/24	○	○	○	-	○	dis 96/24	L, C, R, SL, SR, LFE	
	DTS (5.1ch)	DTS 5.1	○	○	○	-	○	dis	L, C, R, SL, SR, LFE	
	PCM(Audio)	PCM (Stereo)	○	-	-	-	-	PCM	L, R	
	PCM 96kHz	PCM (96kHz Stereo)	○	-	-	-	-	PCM	L, R	
	AAC (5.1ch)	AAC 5.1	○	○	○	-	○	AAC	L, C, R, SL, SR, LFE	
	AAC (2ch)	AAC 2.0	○	-	-	-	-	AAC	L, R	
	Analog	Stereo	○	-	-	-	-	ANALOG	-	
	S-DIRECT	Dolby D Surr. EX	Dolby Digital EX	○	○	○	○	○	DD DIGITAL	L, C, R, SL, SR, S, LFE
		Dolby D (5.1ch)	Dolby Digital 5.1	○	○	○	-	○	DD DIGITAL	L, C, R, SL, SR, LFE
Dolby D (2ch)		Dolby Digital 2.0	○	-	-	-	-	DD DIGITAL	L, R	
Dolby D (2ch Surr)		Pro Logic IIx movie	○	○	○	○	*	DD DIGITAL, DD SURROUND	L, R, S	
DTS-ES		DTS-ES	○	○	○	○	○	dis, ES	L, C, R, SL, SR, S, LFE	
DTS 96/24		DTS 96/24	○	○	○	-	○	dis 96/24	L, C, R, SL, SR, LFE	
DTS (5.1ch)		DTS 5.1	○	○	○	-	○	dis	L, C, R, SL, SR, LFE	
PCM (Audio)		PCM (Stereo)	○	-	-	-	-	PCM	L, R	
PCM 96kHz		PCM (96kHz Stereo)	○	-	-	-	-	PCM	L, R	
AAC (5.1ch)		AAC 5.1	○	○	○	-	○	AAC	L, C, R, SL, SR, LFE	
AAC (2ch)		AAC 2.0	○	-	-	-	-	AAC	L, R	
Analog		Stereo	○	-	-	-	-	ANALOG	-	
EX/ES		Dolby D Surr. EX	Dolby Digital EX	○	○	○	○	○	DD DIGITAL	L, C, R, SL, SR, S, LFE
		Dolby D (5.1ch)	Dolby Digital EX	○	○	○	○	○	DD DIGITAL	L, C, R, SL, SR, LFE
	DTS-ES	DTS-ES	○	○	○	○	○	dis, ES	L, C, R, SL, SR, S, LFE	
	DTS(5.1ch)	DTS-ES	○	○	○	○	○	dis	L, C, R, SL, SR, LFE	
	AAC (5.1ch)	AAC EX	○	○	○	-	○	AAC	L, C, R, SL, SR, LFE	
DOLBY (PL IIx movie) (PL IIx music) (PL IIx game) (Pro Logic)	Dolby D Surr. EX	Dolby Digital 5.1	○	○	○	○	○	DD DIGITAL	L, C, R, SL, SR, S, LFE	
	Dolby D (5.1ch)	Dolby Digital 5.1	○	○	○	-	○	DD DIGITAL	L, C, R, SL, SR, LFE	
	Dolby D (2ch)	Pro Logic IIx	○	○	○	○	*	DD DIGITAL	L, R	
	Dolby D (2ch Surr)	Pro Logic IIx	○	○	○	○	*	DD DIGITAL, DD SURROUND	L, R, S	
	PCM (Audio)	Pro Logic IIx	○	○	○	○	*	PCM	L, R	
	AAC (2ch)	Pro Logic IIx	○	○	○	○	*	AAC	L, R	
	Analog	Pro Logic IIx	○	○	○	○	*	ANALOG	-	
DTS (Neo:6 Cinema) (Neo:6 Music)	DTS-ES	DTS 5.1	○	○	○	-	○	dis, ES	L, C, R, SL, SR, S, LFE	
	DTS 96/24	DTS 96/24	○	○	○	-	○	dis 96/24	L, C, R, SL, SR, LFE	
	DTS (5.1ch)	DTS 5.1	○	○	○	-	○	dis	L, C, R, SL, SR, LFE	
	PCM (Audio)	Neo:6	○	○	○	○	*	PCM	L, R	
	Analog	Neo:6	○	○	○	○	*	ANALOG	-	
	Dolby D (2ch)	Neo:6	○	○	○	○	*	DD DIGITAL	L, R	
	Dolby D (2ch Surr)	Neo:6	○	○	○	○	*	DD DIGITAL, 2 SURROUND	L, R, S	
	AAC (2ch)	Neo:6	○	○	○	○	*	AAC	L, R	
CS II Cinema CS II Music CS II Mono	PCM (Audio)	CS II	○	○	○	○	○	PCM	L, R	
	Analog	CS II	○	○	○	○	○	ANALOG	-	
	Dolby D (2ch)	CS II	○	○	○	○	○	DD DIGITAL	L, R	
	Dolby D (2ch Surr)	CS II	○	○	○	○	○	DD DIGITAL, 2 SURROUND	L, R, S	
STEREO	AAC (2ch)	CS II	○	○	○	○	○	AAC	L, R	
	Dolby Surr. EX	Stereo	○	-	-	-	○	DD DIGITAL	L, C, R, SL, SR, S, LFE	
	Dolby D (5.1ch)	Stereo	○	-	-	-	○	DD DIGITAL	L, C, R, SL, SR, LFE	
	Dolby D (2ch)	Stereo	○	-	-	-	*	DD DIGITAL	L, R	
	Dolby D (2ch Surr)	Stereo	○	-	-	-	*	DD DIGITAL, DD SURROUND	L, R, S	
	DTS-ES	Stereo	○	-	-	-	○	dis, ES	L, C, R, SL, SR, S, LFE	
	DTS 96/24	Stereo	○	-	-	-	○	dis 96/24	L, C, R, SL, SR, LFE	
	DTS (5.1ch)	Stereo	○	-	-	-	○	dis	L, C, R, SL, SR, LFE	
	PCM (Audio)	Stereo	○	-	-	-	*	PCM	L, R	
	PCM 96kHz	Stereo	○	-	-	-	*	PCM	L, R	
	AAC (5.1ch)	Stereo	○	-	-	-	○	AAC	L, C, R, SL, SR, LFE	
	AAC (2ch)	Stereo	○	-	-	-	*	AAC	L, R	
	Analog	Stereo	○	-	-	-	*	ANALOG	-	
	Virtual	Dolby Surr. EX	Virtual	○	-	-	-	-	DD DIGITAL	L, C, R, SL, SR, S, LFE
Dolby D (5.1ch)		Virtual	○	-	-	-	-	DD DIGITAL	L, C, R, SL, SR, LFE	
Dolby D (2ch)		Virtual	○	-	-	-	-	DD DIGITAL	L, R	
Dolby D (2ch Surr)		Virtual	○	-	-	-	-	DD DIGITAL, DD SURROUND	L, R, S	
DTS-ES		Virtual	○	-	-	-	-	dis, ES	L, C, R, SL, SR, S, LFE	
DTS (5.1ch)		Virtual	○	-	-	-	-	dis	L, C, R, SL, SR, LFE	
PCM (Audio)		Virtual	○	-	-	-	-	PCM	L, R	
AAC (5.1ch)		Virtual	○	-	-	-	-	AAC	L, C, R, SL, SR, LFE	
AAC (2ch)		Virtual	○	-	-	-	-	AAC	L, R	
Analog		Virtual	○	-	-	-	-	ANALOG	-	
Multi Ch. Stereo	Dolby Surr. EX	Dolby Digital EX	○	○	○	○	○	DD DIGITAL	L, C, R, SL, SR, S, LFE	
	Dolby D (5.1ch)	Dolby Digital 5.1	○	○	○	-	○	DD DIGITAL	L, C, R, SL, SR, LFE	
	Dolby D (2ch)	Multi Channel Stereo	○	○	○	○	*	DD DIGITAL	L, R	
	Dolby D (2ch Surr)	Multi Channel Stereo	○	○	○	○	*	DD DIGITAL, DD SURROUND	L, R, S	
	DTS-ES	DTS-ES	○	○	○	○	○	dis, ES	L, C, R, SL, SR, S, LFE	
	DTS (5.1ch)	DTS 5.1	○	○	○	-	○	dis	L, C, R, SL, SR, LFE	
	PCM (Audio)	Multi Channel Stereo	○	○	○	○	*	PCM	L, R	
	AAC (5.1ch)	AAC 5.1	○	○	○	-	○	AAC	L, C, R, SL, SR, LFE	
	AAC (2ch)	Multi Channel	○	○	○	○	*	AAC	L, R	
	Analog	Multi Channel Stereo	○	○	○	○	*	ANALOG	-	

- Dolby Digital (2ch Surr) :
ドルビーサラウンド処理されたドルビーデジタル2ch信号
- * : サブウパー他のスピーカーのLarge/Smallによってサブウパー出力は異なります。

L/R : フロントスピーカー
 C : センタースピーカー
 SL/SR : サラウンドスピーカー
 SBL/SBR : サラウンドバックスピーカー
 SubW : サブウパースピーカー

2. TECHNICAL DESCRIPTION



DTS was introduced in 1994 to provide 5.1 channels of discrete digital audio into home theater systems.

DTS brings you premium quality discrete multichannel digital sound to both movies and music.

DTS is a multichannel sound system designed to create full range digital sound reproduction.

The no compromise DTS digital process sets the standard of quality for cinema sound by delivering an exact copy of the studio master recordings to neighborhood and home theaters.

Now, every moviegoer can hear the sound exactly as the moviemaker intended.

DTS can be enjoyed in the home for either movies or music on of DVD's, LD's, and CD's.

"DTS" and "DTS Digital Surround" are registered trademarks of Digital Theater Systems, Inc.



The advantages of discrete multichannel systems over matrix are well known.

But even in homes equipped for discrete multichannel, there remains a need for high-quality matrix decoding. This is because of the large library of matrix surround motion pictures available on disc and on VHS tape; and analog television broadcasts.

The typical matrix decoder of today derives a center channel and a mono surround channel from two-channel matrix stereo material. It is better than a simple matrix in that it includes steering logic to improve separation, but because of its mono, band-limited surround it can be disappointing to users accustomed to discrete multichannel.

Neo:6 offers several important improvements as follow,

- Neo:6 provides up to six full-band channels of matrix decoding from stereo matrix material. Users with 6.1 and 5.1 systems will derive six and five separate channels, respectively, corresponding to the standard home-theater speaker layouts.
- Neo:6 technology allows various sound elements within a channel or channels to be steered separately, and in a way which follows naturally from the original presentation.

- Neo:6 offers a music mode to expand stereo nonmatrix recordings into the five- or six-channel layout, in a way which does not diminish the subtlety and integrity of the original stereo recording.



DTS-ES Extended Surround is a new multichannel digital signal format developed by Digital Theater Systems Inc. While offering high compatibility with the conventional DTS Digital Surround format, DTS-ES Extended Surround greatly improves the 360-degree surround impression and space expression thanks to further expanded surround signals. This format has been used professionally in movie theaters since 1999.

In addition to the 5.1 surround channels (FL, FR, C, SL, SR and LFE), DTS-ES Extended Surround also offers the SB (Surround Back) channel for surround playback with a total of 6.1 channels. DTS-ES Extended Surround includes two signal formats with different surround signal recording methods, as DTS-ES Discrete 6.1 and DTS-ES Matrix 6.1.

"DTS", "DTS-ES Extended Surround" and "Neo:6" are trademarks of Digital Theater Systems, Inc.



The stereo CD is a 16-bit medium with sampling at 44.1 kHz. Professional audio has been 20- or 24-bit for some time, and there is increasing interest in higher sampling rates both for recording and for delivery into the home. Greater bit depths provide extended dynamic range. Higher sampling rates allow wider frequency response and the use of anti-alias and reconstruction filters with more favorable aural characteristics.

DTS 96/24 allows for 5.1 channel sound tracks to be encoded at a rate of 96kHz/24bits on DVD-Video titles.

When DVD-video appeared, it became possible to deliver 24-bit, 96 kHz audio into the home, but only in two channels, and with serious limitations on picture. This capability has had little use. DVD-audio allows 96/24 in six channels, but a new player is needed, and only analog outputs are provided, necessitating the use of the D/A converters and analog electronics provided in the player.

DTS 96/24 offers the following:

1. Sound quality transparent to the original 96/24 master.
2. Full backward compatibility with all existing decoders. (Existing decoders will output a 48 kHz signal)
3. No new player required: DTS 96/24 can be carried on DVD-video, or in the video zone of DVD-audio, accessible to all DVD players.
4. 96/24 5.1-channel sound with full-quality full-motion video, for music programs and motion picture soundtracks on DVD-video.



Dolby Digital identifies the use of Dolby Digital audio coding for such consumer formats as DVD and DTV. As with film sound, Dolby Digital can provide up to five full-range channels for left, center, and right screen channels, independent left and right surround channels, and a sixth (".1") channel for low-frequency effects.

Dolby Surround Pro Logic II is an improved matrix decoding technology that provides better spatiality and directionality on Dolby Surround program material; provides a convincing three-dimensional soundfield on conventional stereo music recordings; and is ideally suited to bring the surround experience to automotive sound. While conventional surround programming is fully compatible with Dolby Surround Pro Logic II decoders, soundtracks will be able to be encoded specifically to take full advantage of Pro Logic II playback, including separate left and right surround channels. (Such material is also compatible with conventional Pro Logic decoders.)

Dolby Digital EX creates six full-bandwidth output channels from 5.1-channel sources. This is done using a matrix decoder that derives three surround channels from the two in the original recording. For best results, Dolby Digital EX should be used with movies soundtracks recorded with Dolby Digital Surround EX.

About Dolby Pro Logic IIx

Dolby Pro Logic IIx technology delivers a natural and immersing 7.1-channel listening experience to the home theater environment. A product of Dolby's expertise in surround sound and matrix decoding technologies, Dolby Pro Logic IIx is a complete surround sound solution that maximizes the entertainment experience from stereo as well as 5.1-channel encoded sources.

Dolby Pro Logic IIx is fully compatible with Dolby Surround Pro Logic technology and can optimally decode the thousands of commercially available Dolby Surround encoded video cassettes and television programs with enhanced depth and spatiality. It can also process any high-quality stereo or Advanced Resolution 5.1-channel music content into a seamless 6.1- or 7.1-channel listening experience.

Manufactured under license from Dolby Laboratories. "Dolby", "Pro Logic", and the double-D symbol are trademarks of Dolby Laboratories.



Circle Surround II (CS-II) is a powerful and versatile multichannel technology. CS-II is designed to enable up to 6.1 multichannel surround sound playback from mono, stereo, CS encoded sources and other matrix encoded sources. In all cases the decoder extends it into 6 channels of surround audio and a LFE/subwoofer signal. The CS-II decoder creates a listening environment that places the listener "inside" music performances and dramatically improves both hi-fi audio conventional surround-encoded video material. CS-II provides composite stereo rear channels to greatly improve separation and image positioning – adding a heightened sense of realism to both audio and A/V productions.

CS-II is packed with other useful feature like dialog clarity (SRS Dialog) for movies and cinema-like bass enrichment (TruBass). CS-II can enable the dialog to become clearer and more discernable in movies and it enables the bass frequencies contained in the original programming to more closely achieve low frequencies – overcoming the low frequency limitations of the speakers by full octave.

Circle Surround II, Dialog Clarity, TruBass, SRS and  symbol are trademarks of SRS Labs, Inc. Circle Surround II, Dialog Clarity and TruBass technology are incorporated under license from SRS Labs, Inc.

3. WIRING DIAGRAM

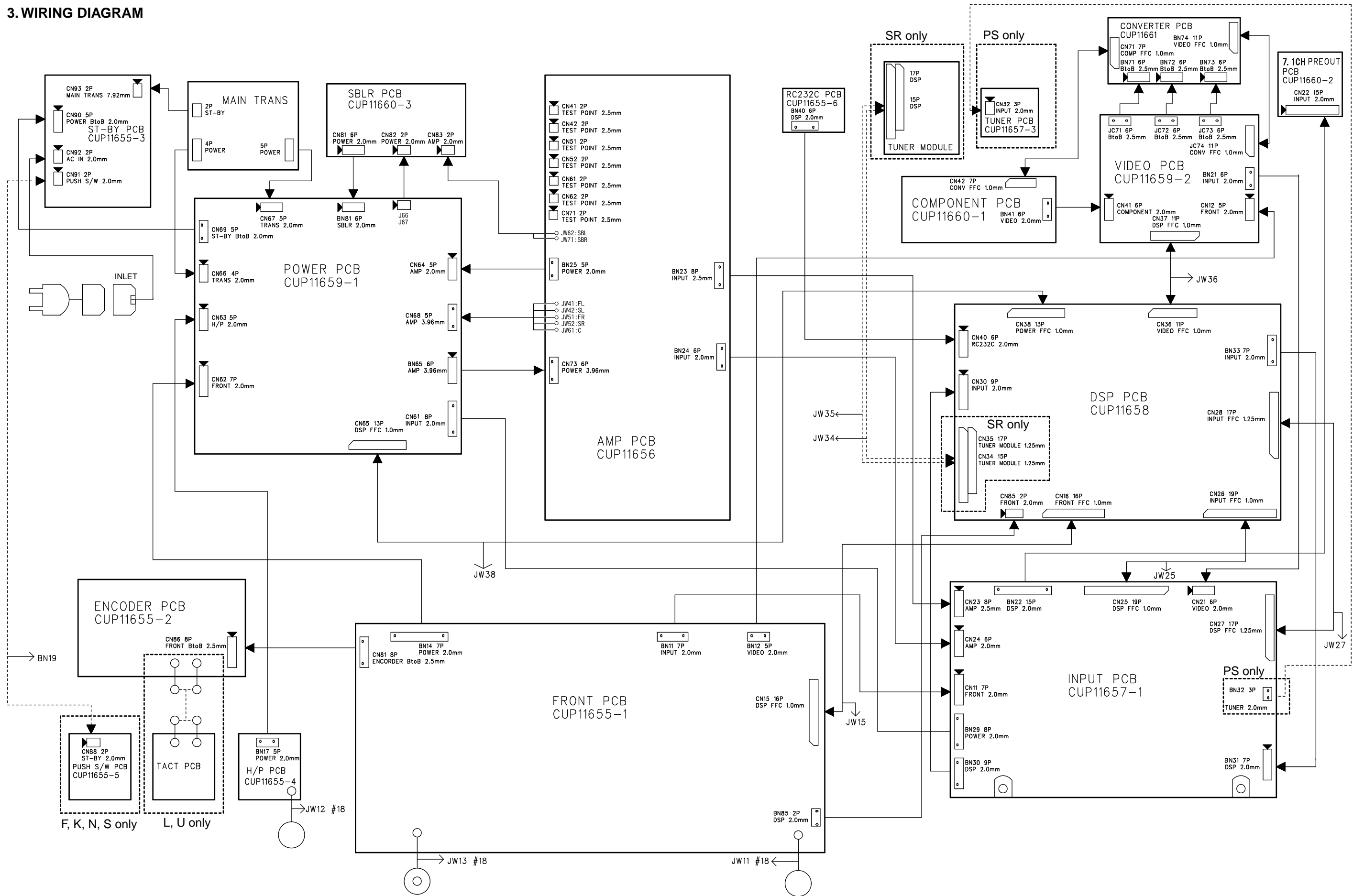

4. BLOCK DIAGRAM

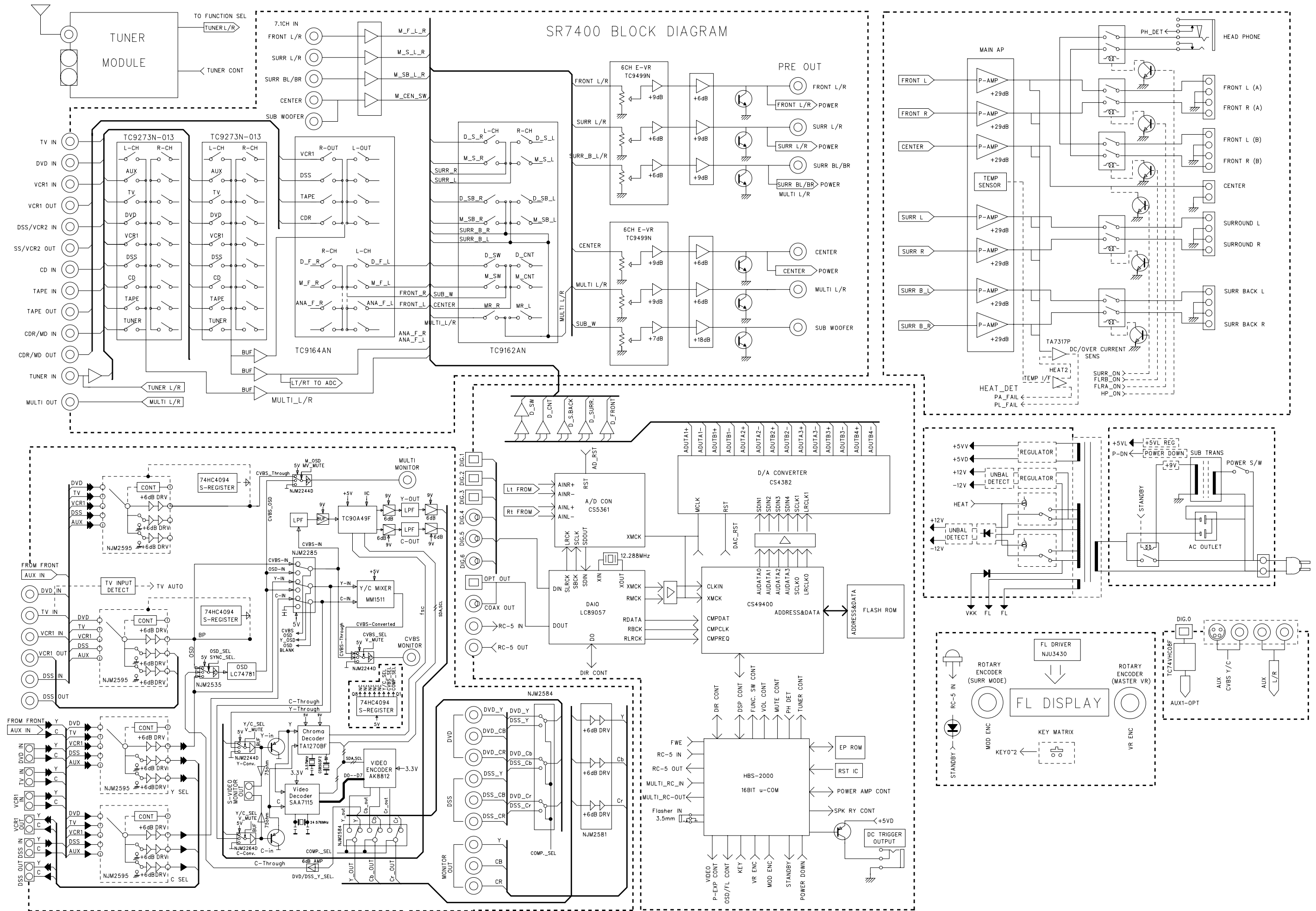

CONVERTER PCB

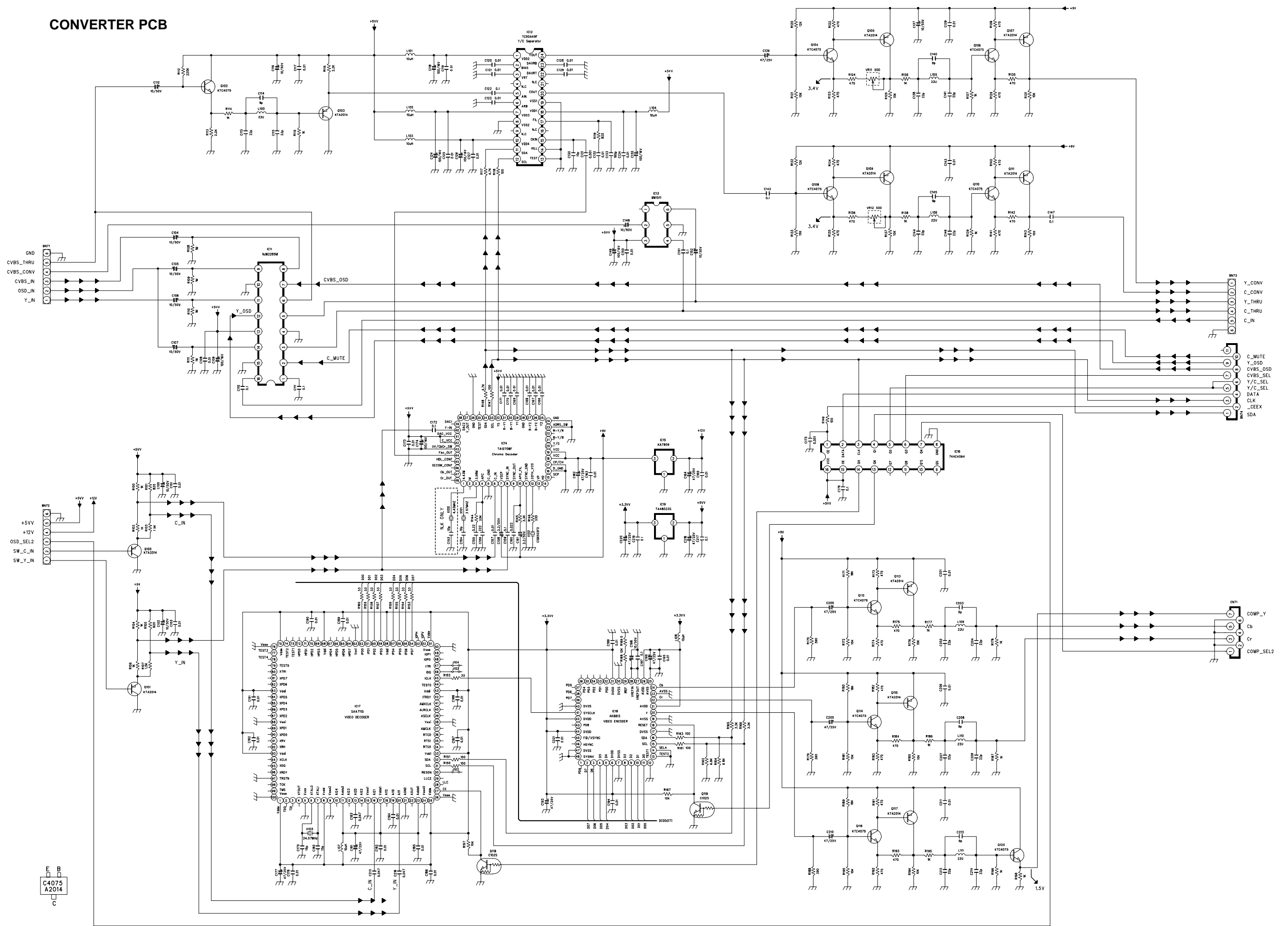

DSP PCB - 1/2

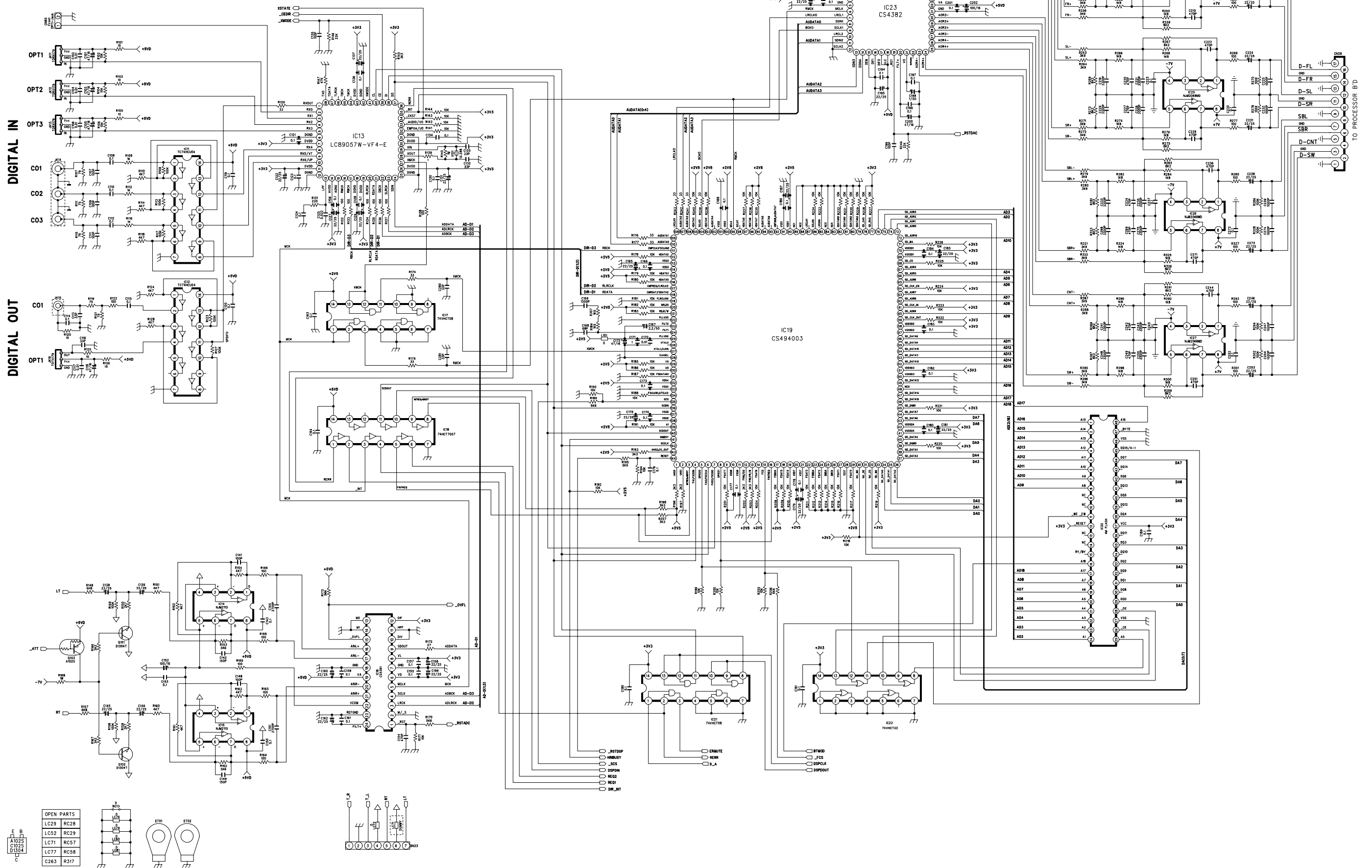

OPEN PARTS

LC29	RC28
LC52	RC29
LC71	RC57
LC77	RC58
C263	R317

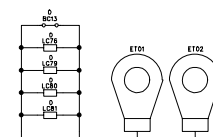

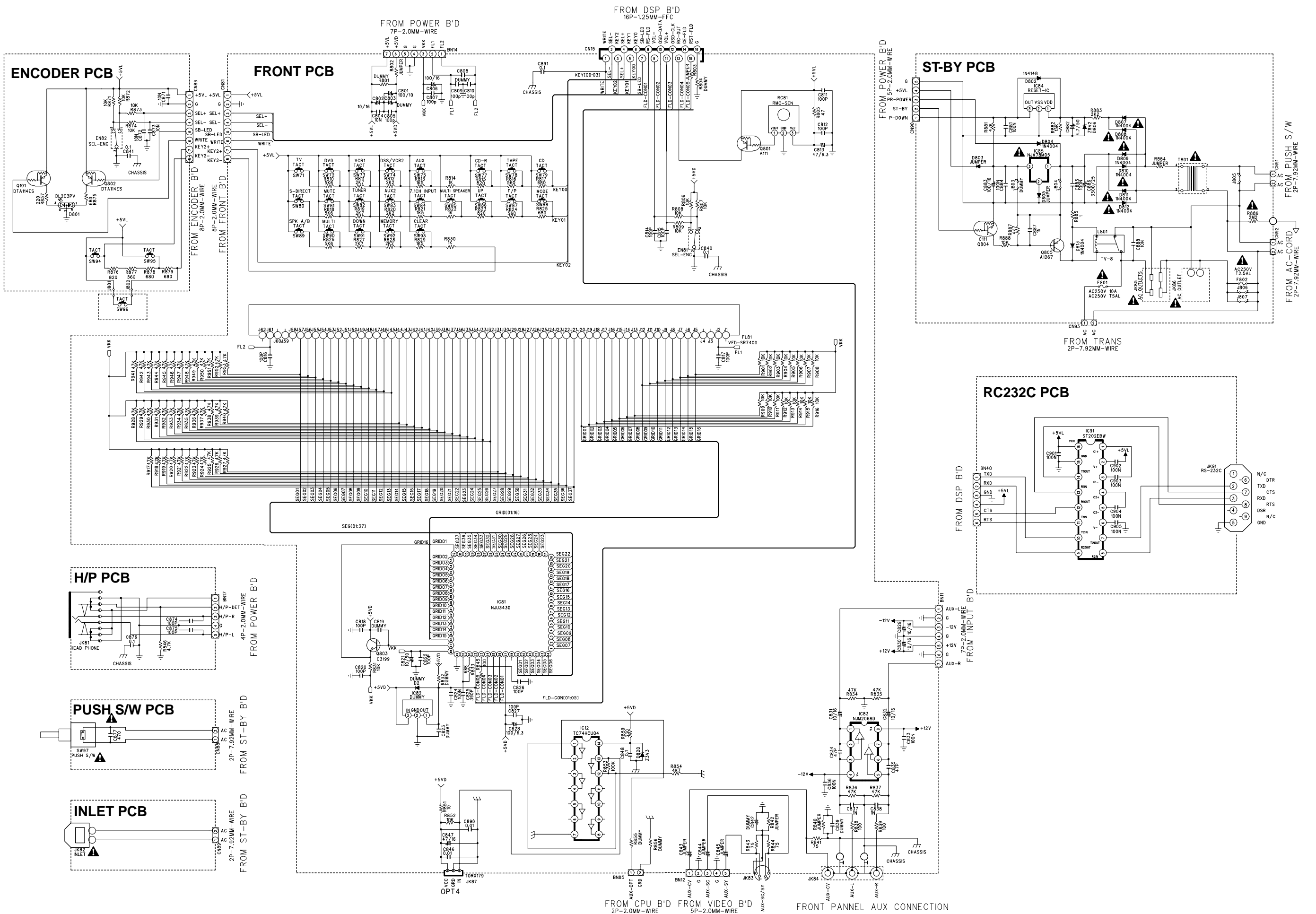

AMP PCB

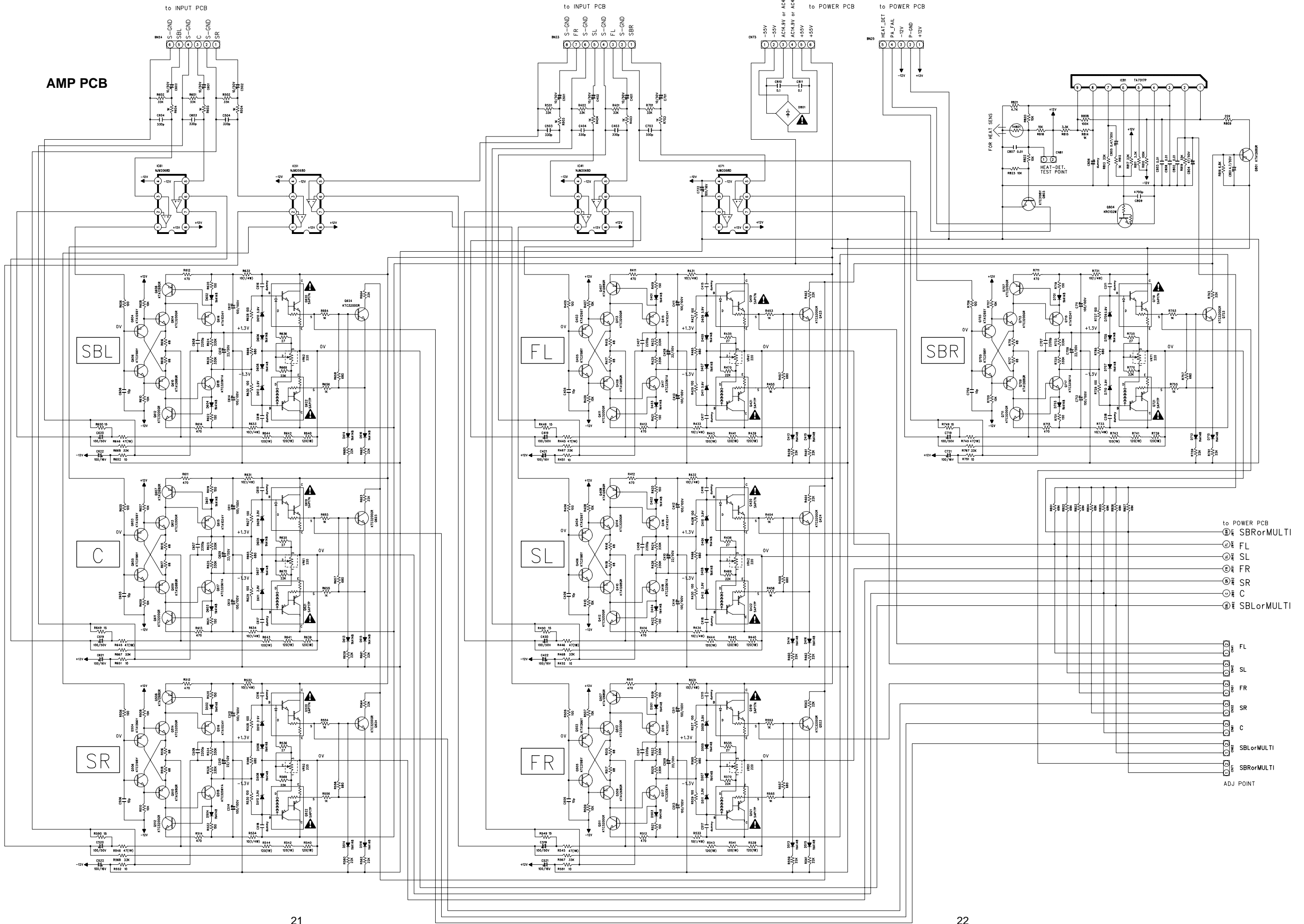

- to POWER PCB
- ① SBRorMULTI
- ② FL
- ③ SL
- ④ FR
- ⑤ SR
- ⑥ C
- ⑦ SBLorMULTI
- ⑧ SBRorMULTI
- ⑨ FL
- ⑩ SL
- ⑪ FR
- ⑫ SR
- ⑬ C
- ⑭ SBLorMULTI
- ⑮ SBRorMULTI
- ⑯ ADJ POINT

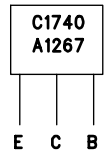
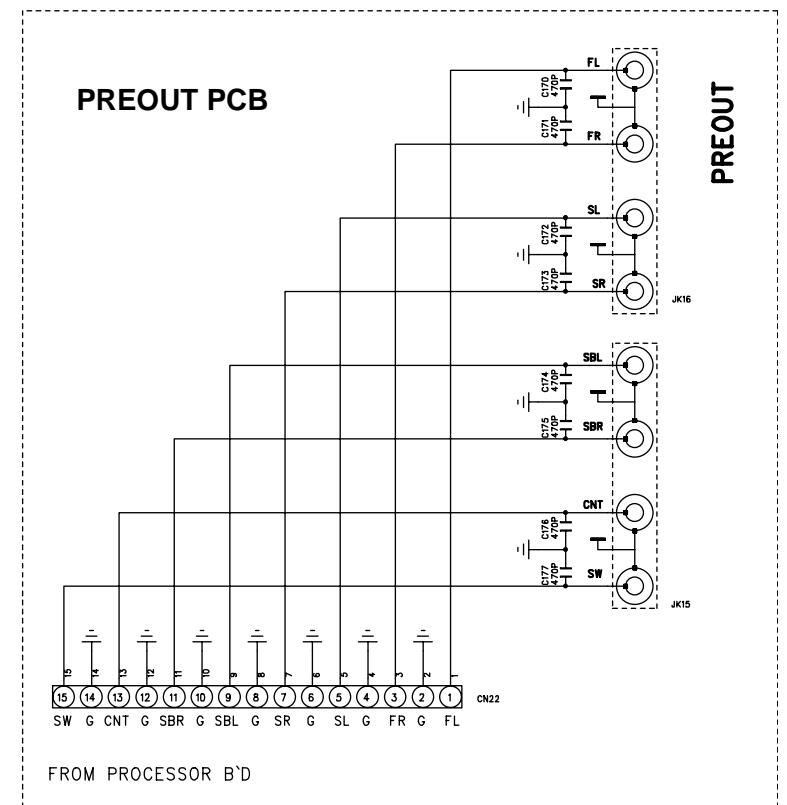
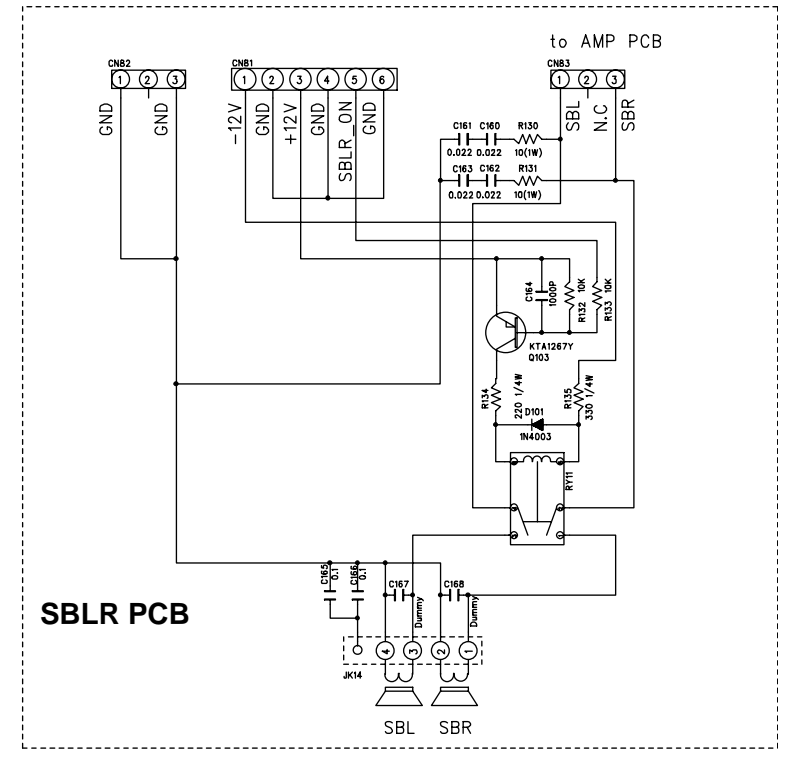
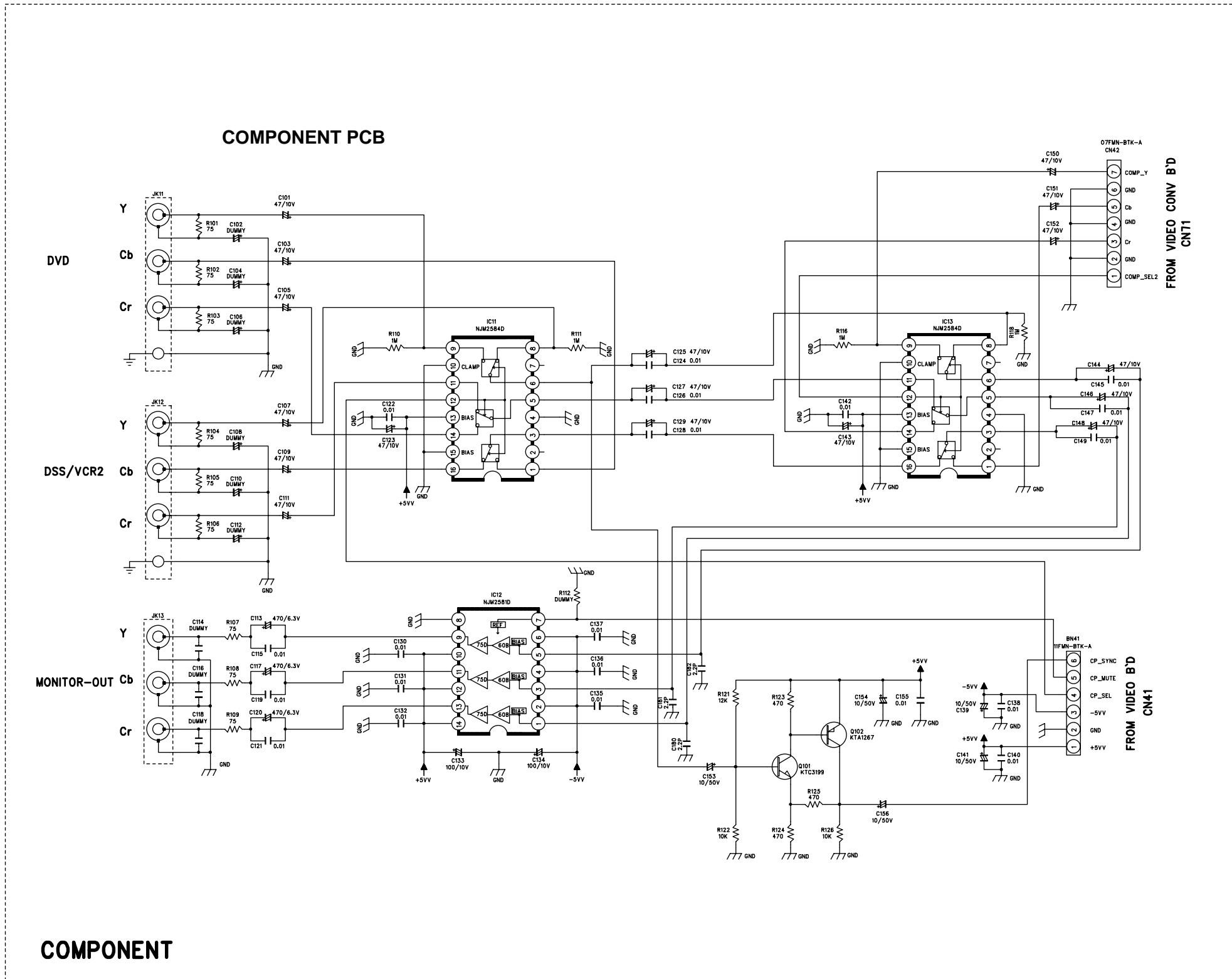

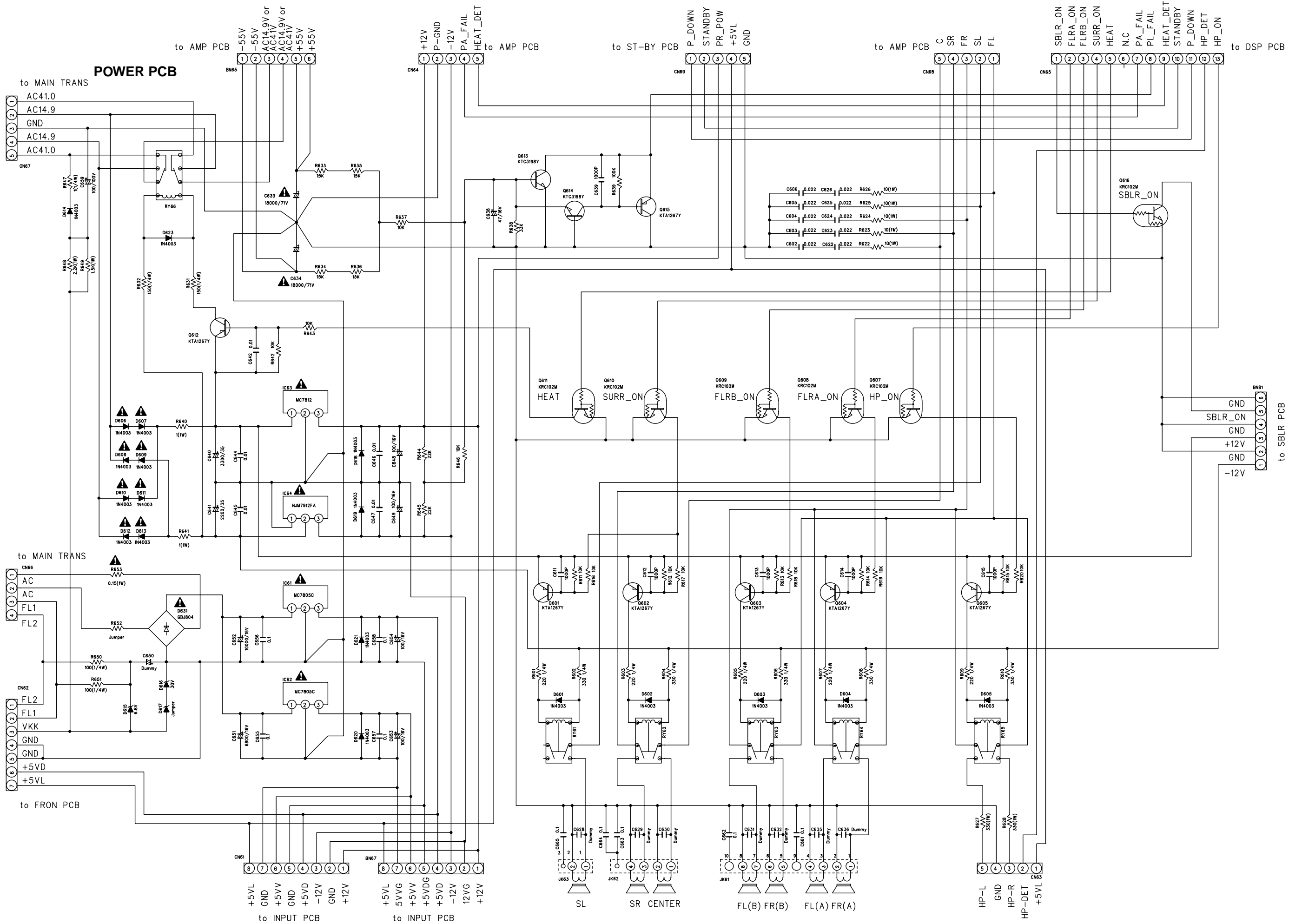

DSP PCB - 2/2

TO FRONT B'D

DOWN LOAD
PUSH SW

RC-5 IN/OUT

MULTI RC

DC OUT
SPEC LOAD
270 OHMS

IR Flasher IN

FROM PROCESSOR B'D

MODEL	RC36	RC37
SR7400	U	OPEN
	N	82K
	S	47K
SR7400 OSE	K	56K
	F	47K
	N	39K
	S	22K
	K	8K2
	F	100K
		OPEN

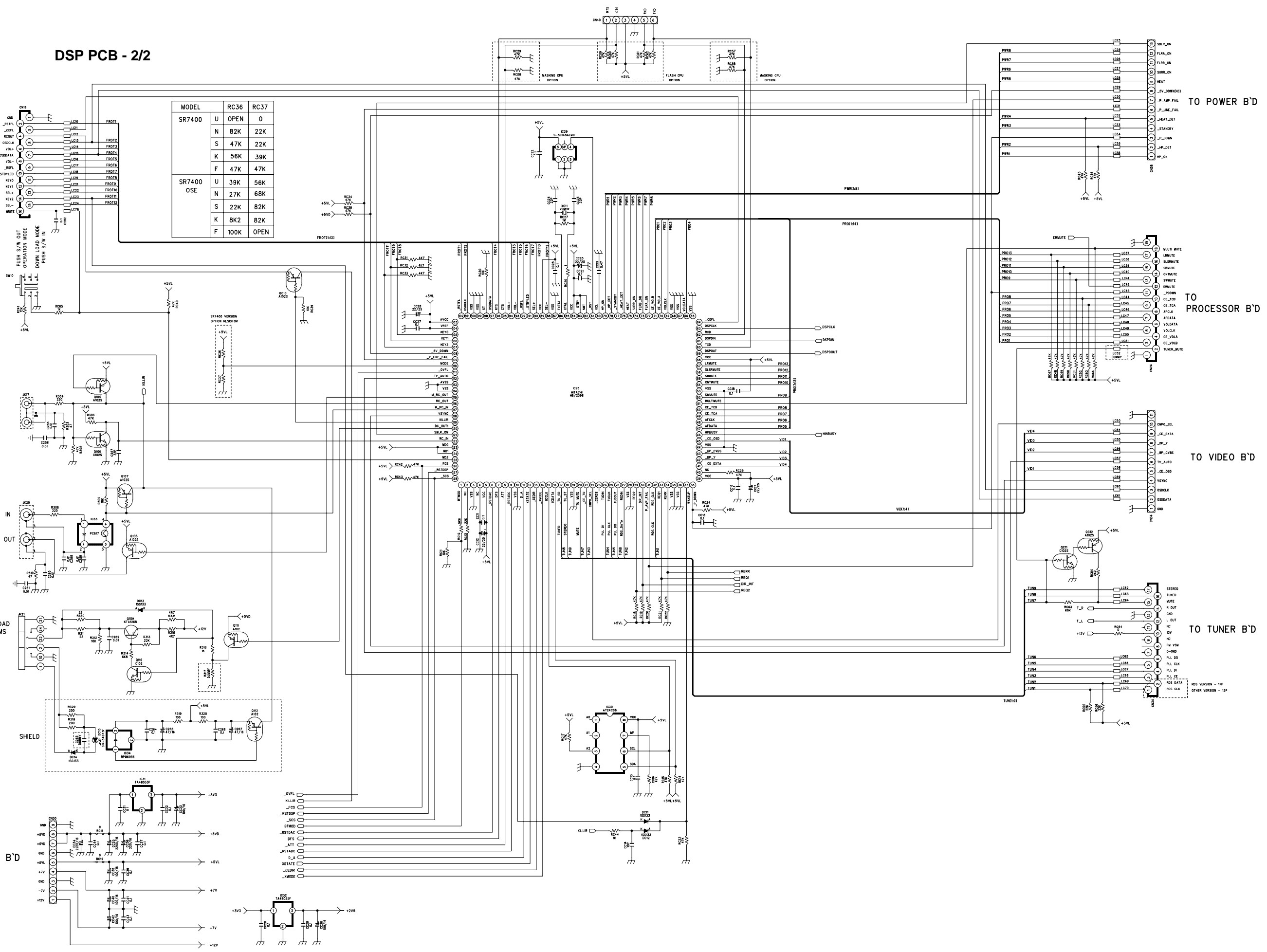

TO POWER B'D

TO PROCESSOR B'D

TO VIDEO B'D

TO TUNER B'D

6. PARTS LOCATION

RS232C

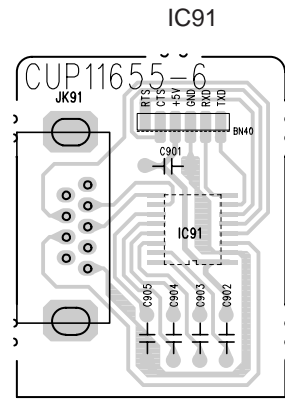

ENCODER & TACT
Q806 Q802

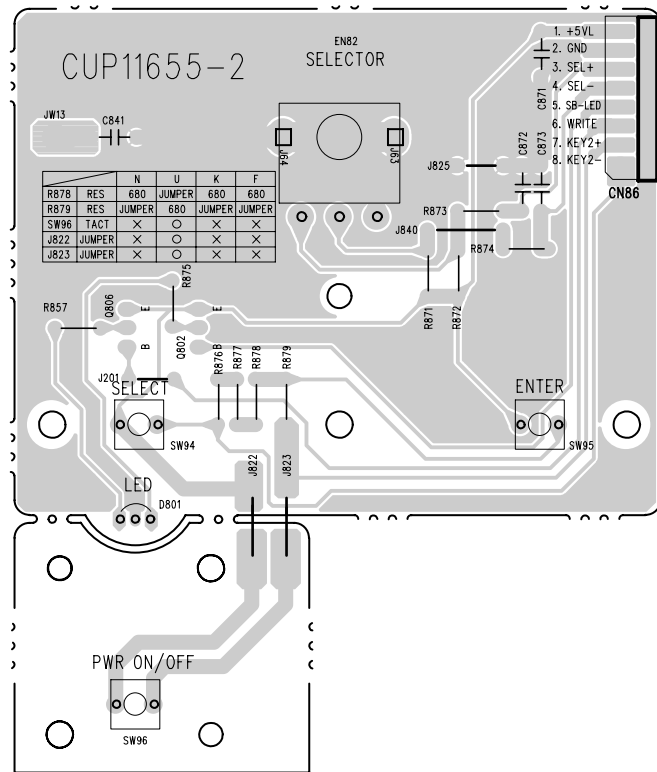

DSP A

- IC11 IC12 Q101 - Q103 IC15 IC14
- Q105 - Q108 IC13 IC17 IC18
- IC33 IC31 IC32
- Q109 - Q112 IC34
- QC12 QC11
- IC19
- IC23
- IC24 - IC27
- IC22
- IC29
- QC10 IC30
- IC28

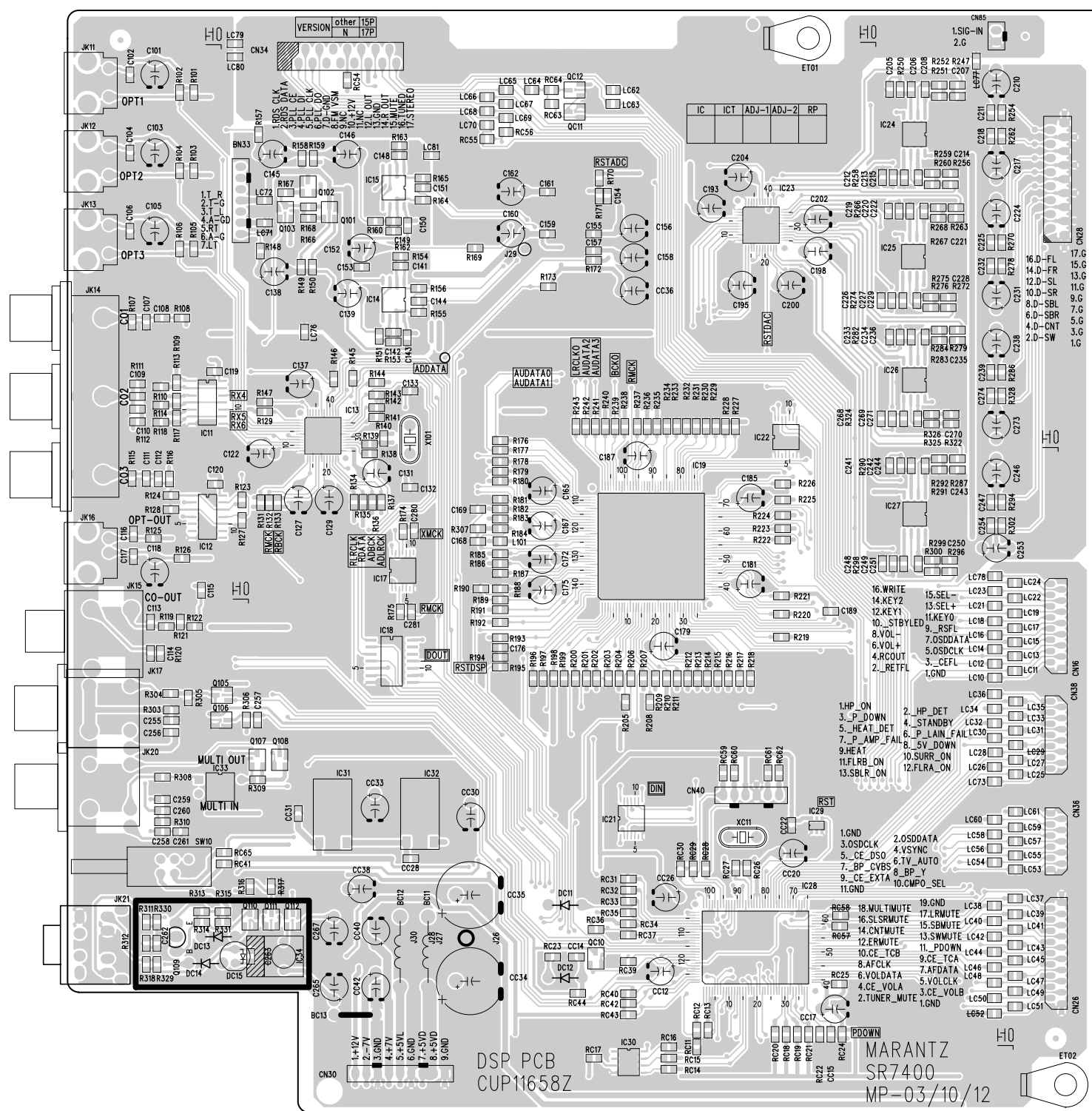

DSP B

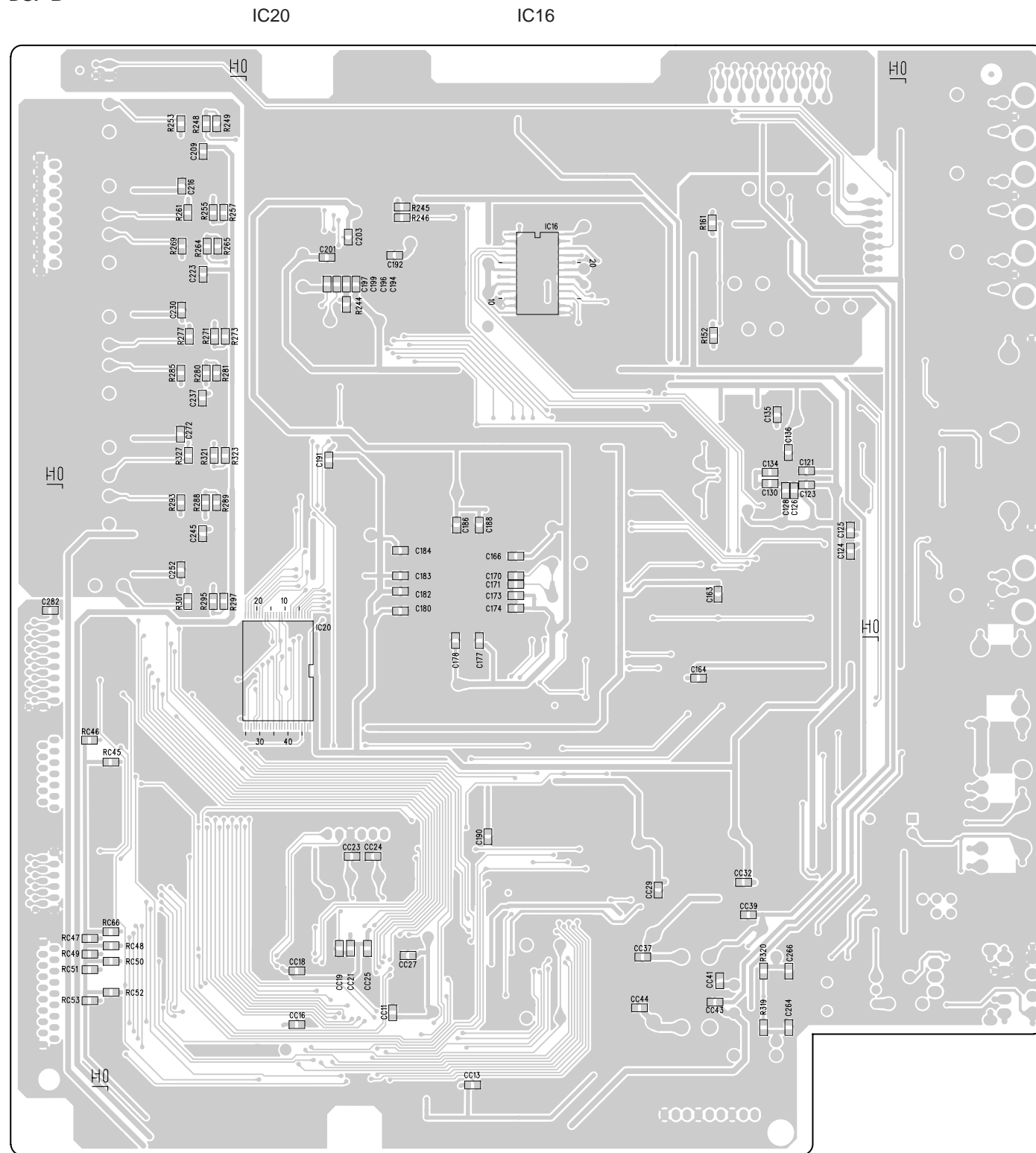

ST-BY

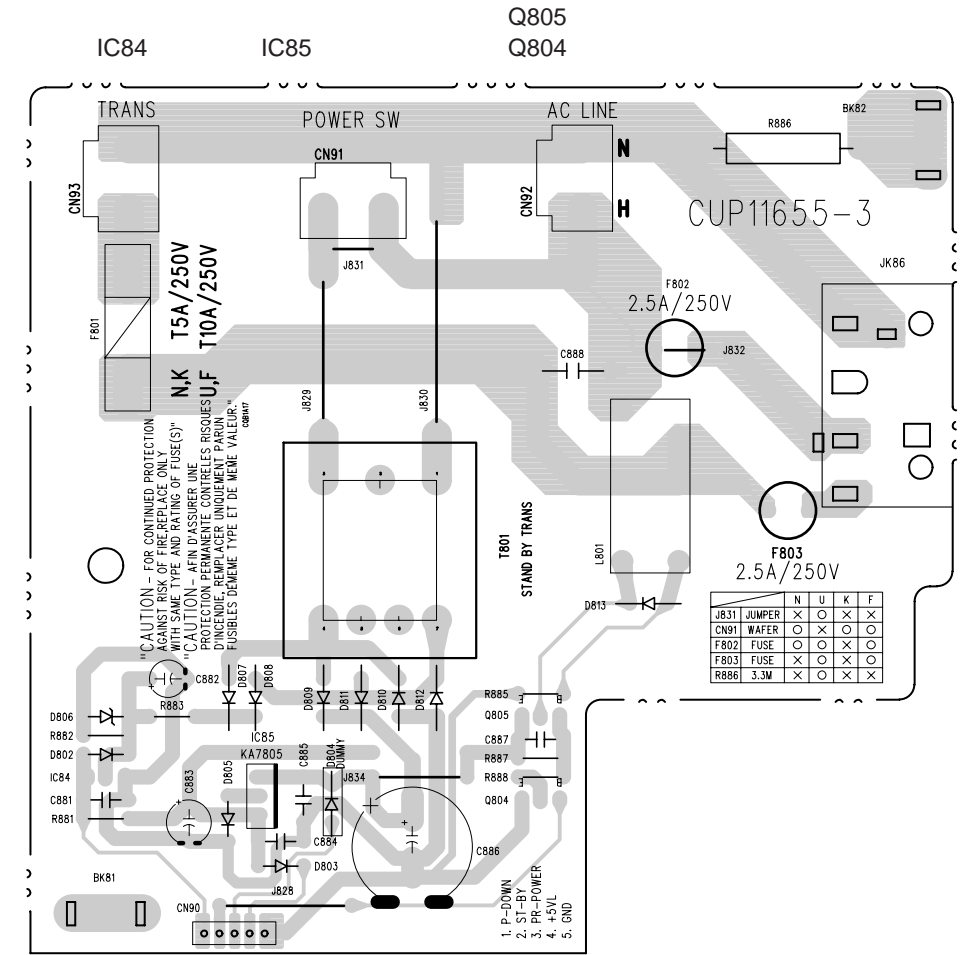

FRONT

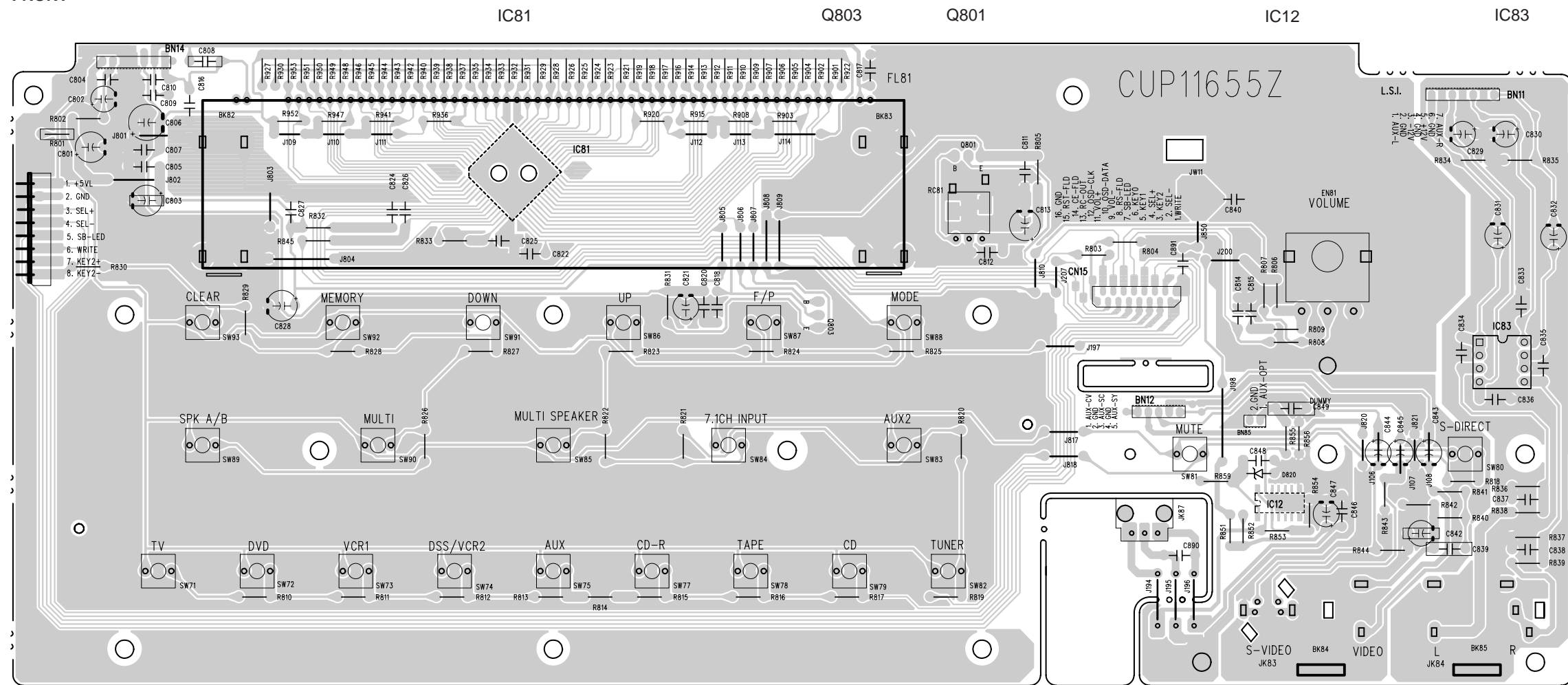

H/P

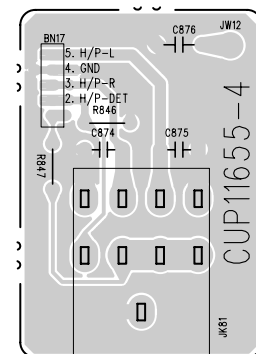

PUSH SW

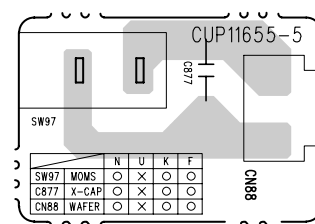

INLET

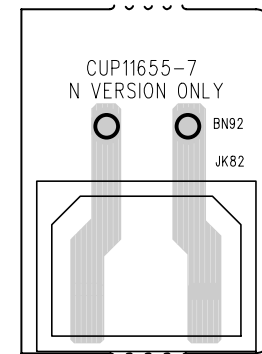

TUNER [PS only]

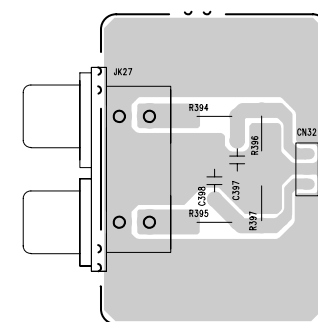

AMP

SBR-CH

SBL-CH

CNT-CH

SR-CH

FR-CH

SL-CH

FL-CH

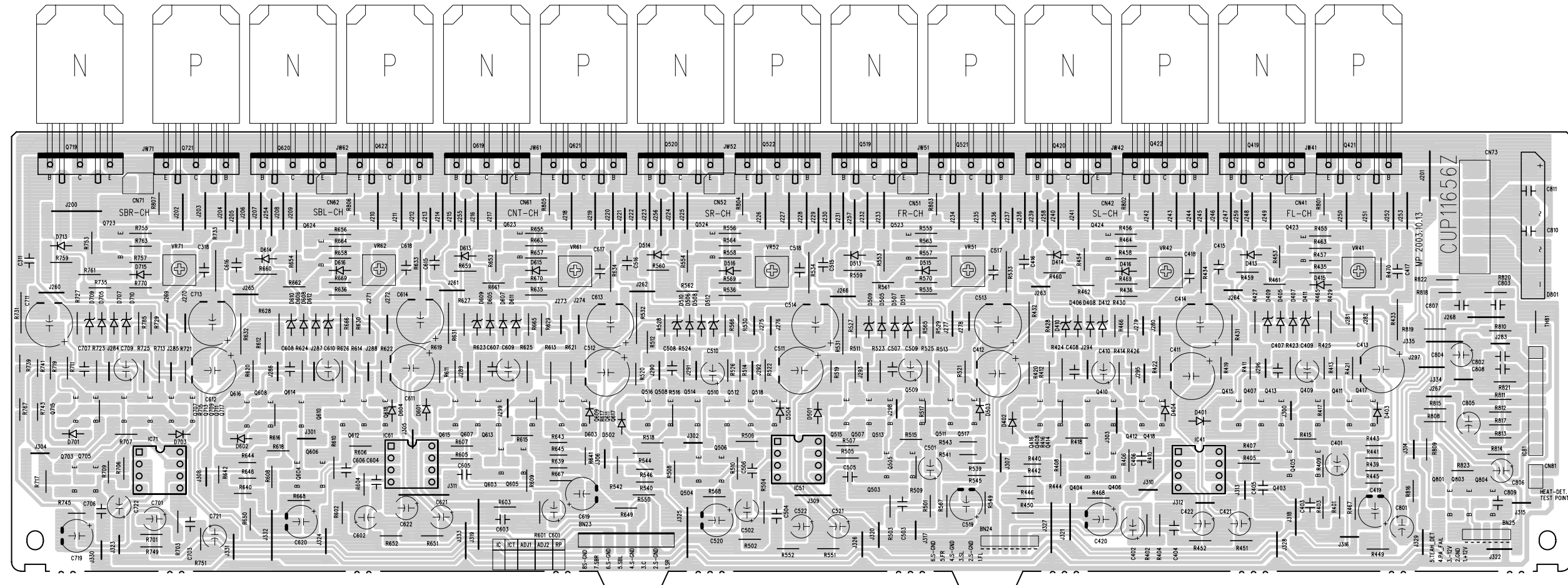

Q719 Q723 Q620 Q622 Q619 Q621 Q520 Q522 Q519 Q521 Q420 Q422 Q419 Q421
 Q715 Q707 Q713 Q709 Q711 Q717 Q624 Q623 Q524 Q523 Q424 Q423 Q415 Q407 Q413 Q409 Q411 Q417
 Q703 Q705 IC71 Q616 Q608 Q614 Q610 Q612 Q618 Q615 Q607 Q613 Q609 Q611 Q617 Q516 Q508 Q514 Q510 Q512 Q518 Q416 Q408 Q414 Q410 Q412 Q418 IC81
 Q703 Q705 IC71 Q604 Q606 IC61 Q603 Q605 Q504 Q506 IC51 Q503 Q505 Q404 Q406 IC41 Q403 Q405 Q801 Q803 Q804

7.1CH PREOUT

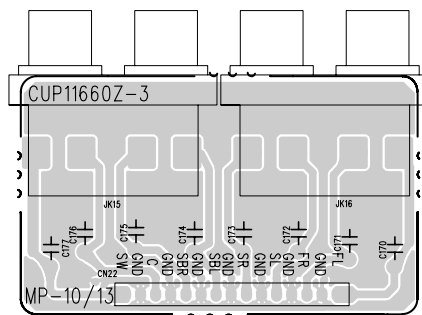

SBLR

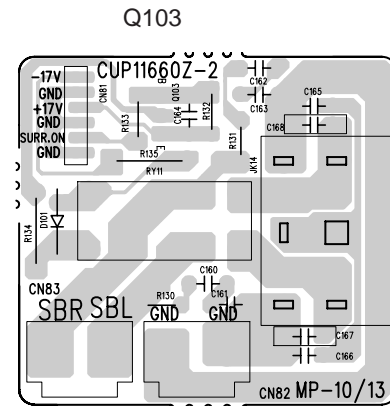

COMPONENT

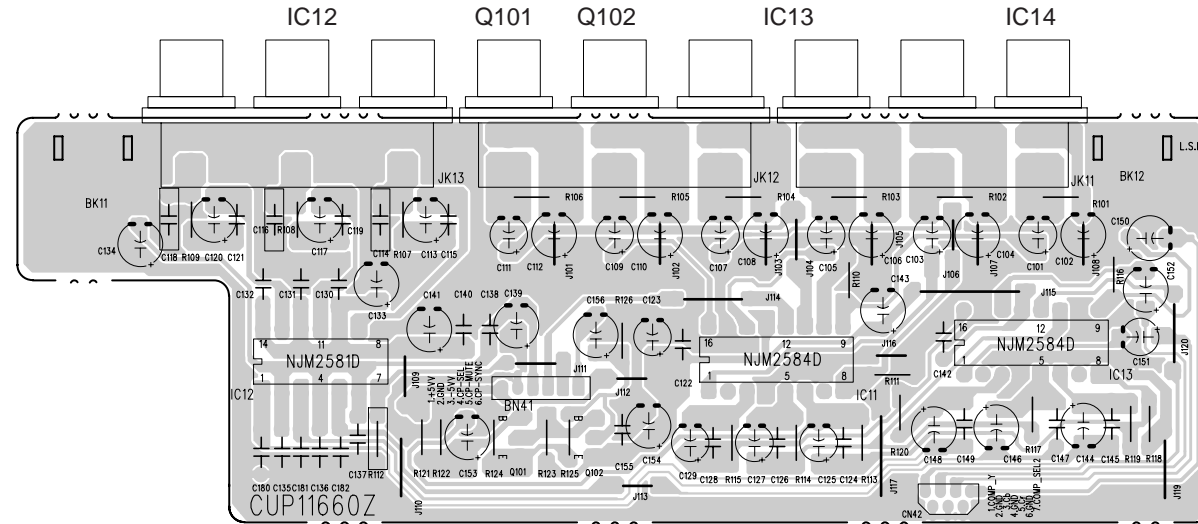

INPUT

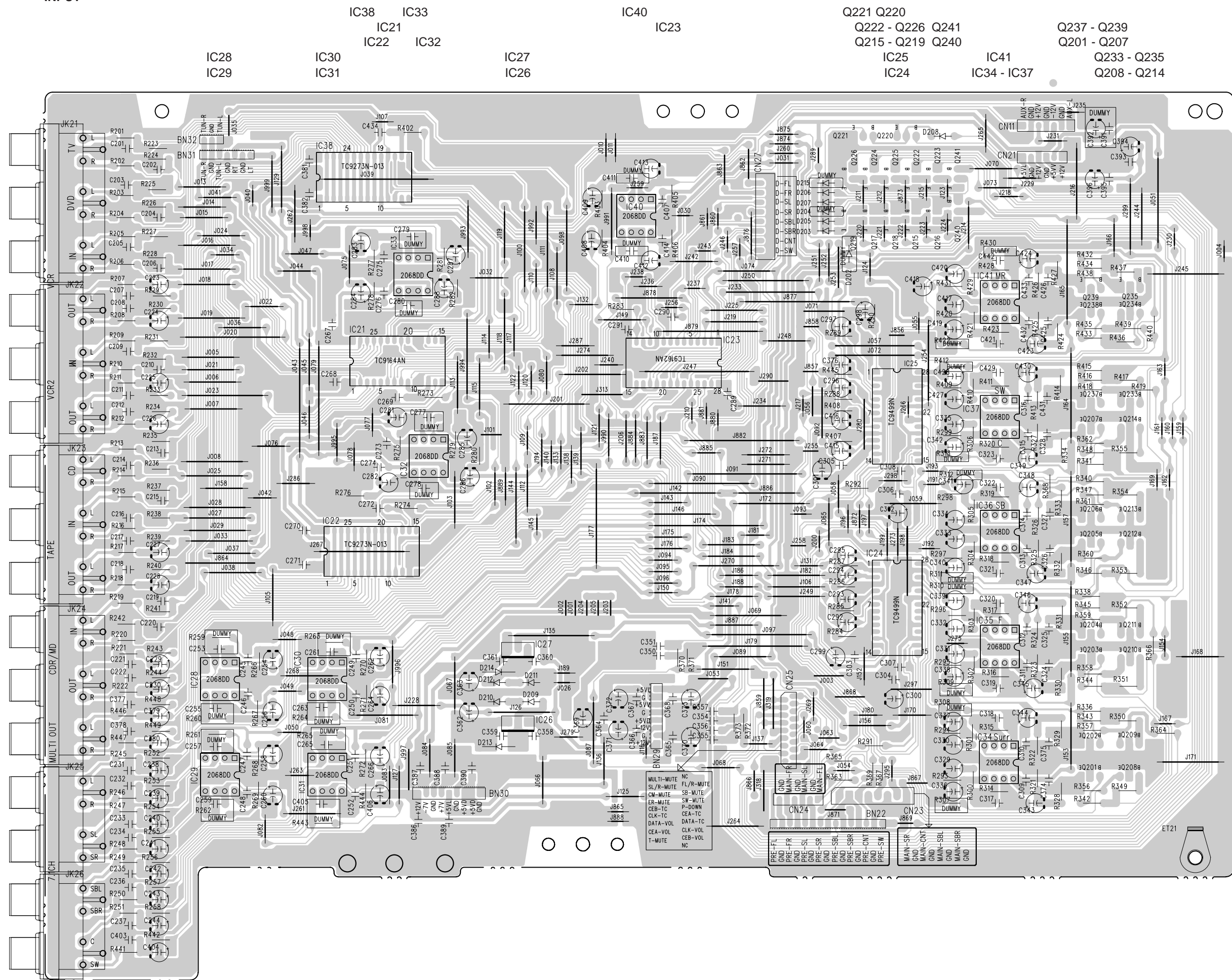

POWER

Q601 Q602 Q603 Q604
Q610 Q609 Q608 Q616
IC61

Q607 Q606
IC62 IC63 IC64

Q615 Q611
Q614 Q612
Q613

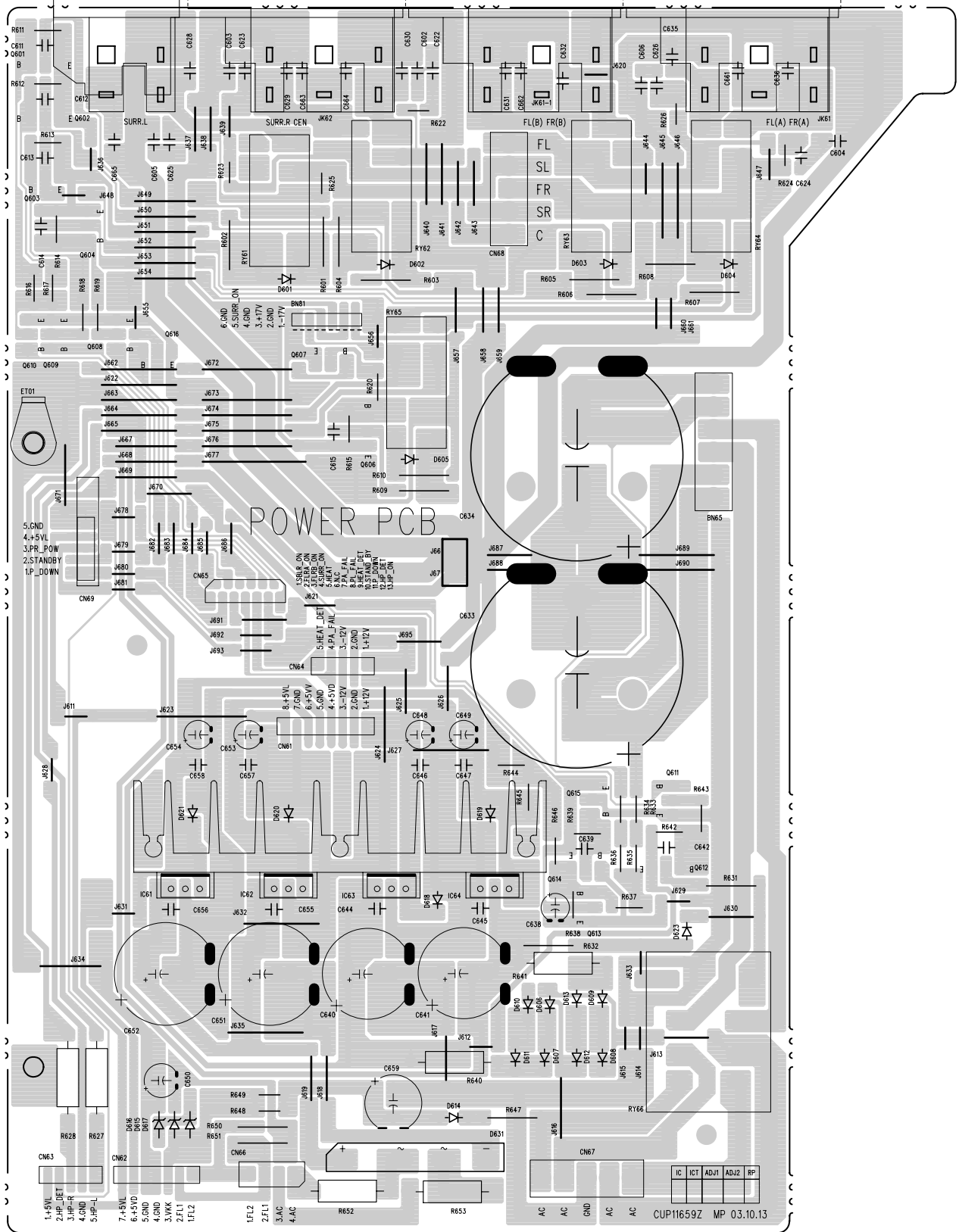

VIDEO

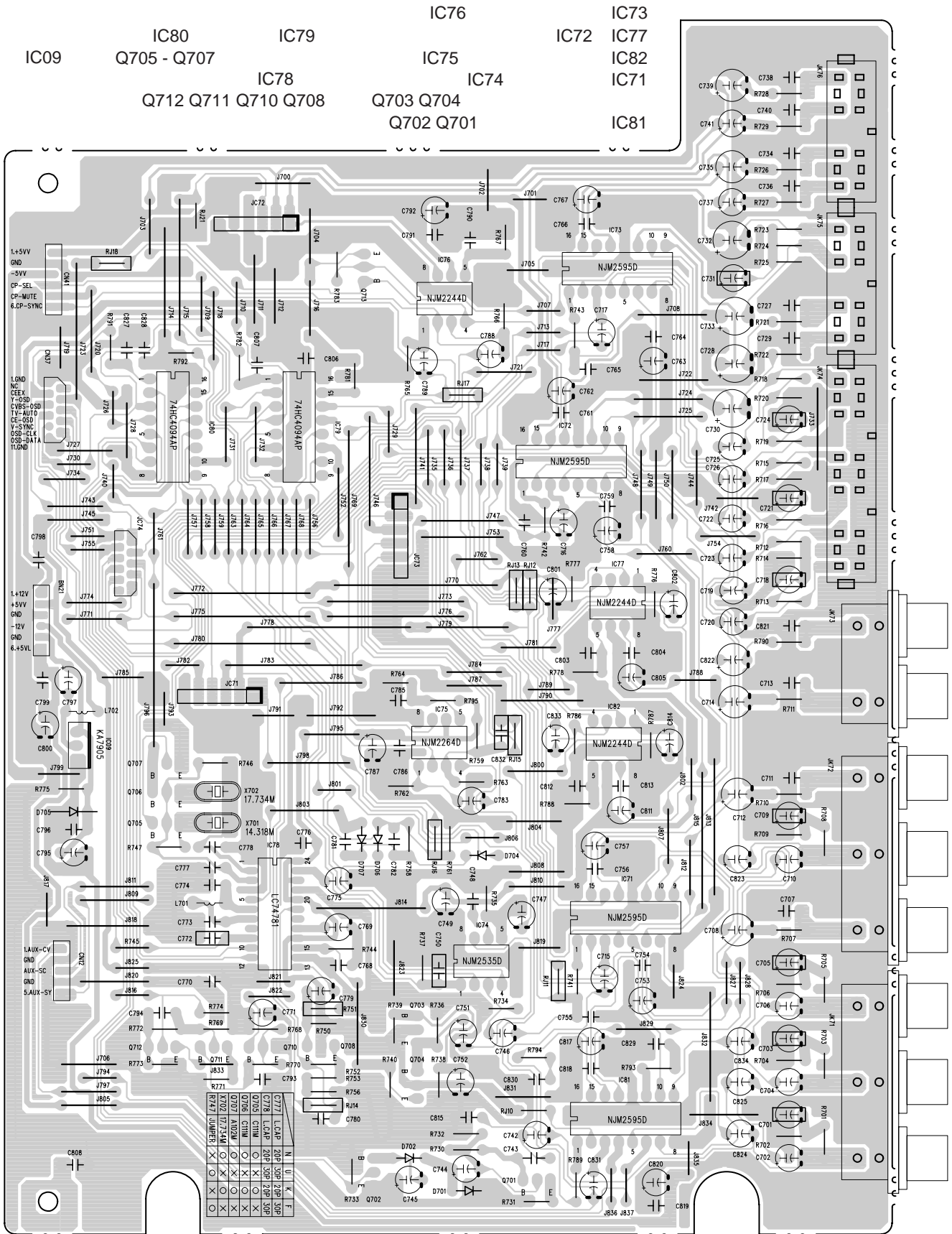

CONVERTER A

IC19	IC17	IC18	Q112	Q113	Q115	Q120
	IC14	Q106	Q110	Q114		Q117
	Q100	Q119	Q104	Q108	IC13	Q116
IC15	Q101	Q118	IC16	IC12		IC11

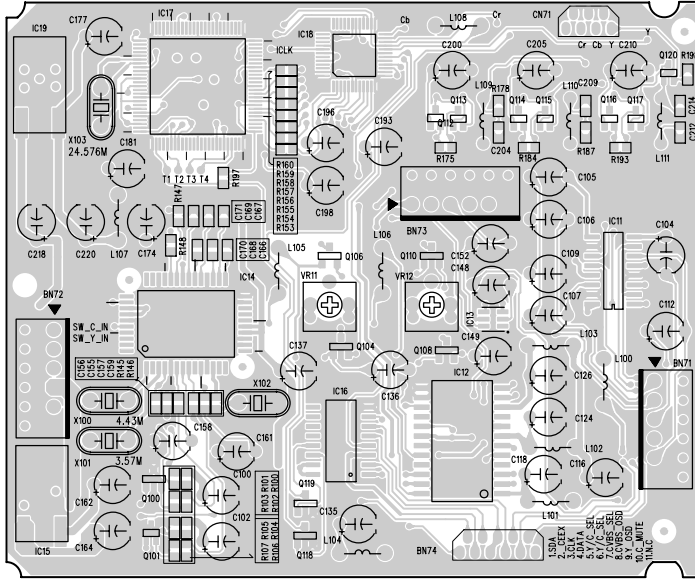

CONVERTER B

	Q111	Q107
Q102	Q103	Q105
	Q109	

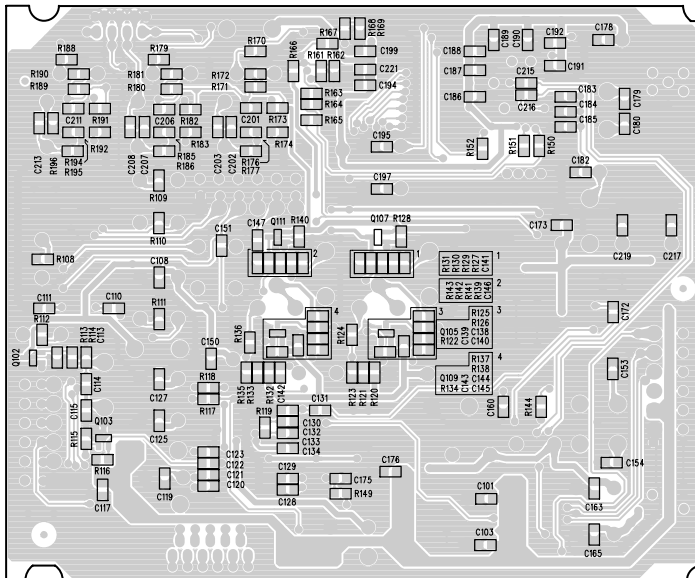

7. IC DATA

IC13 : LC89057W VF4-E

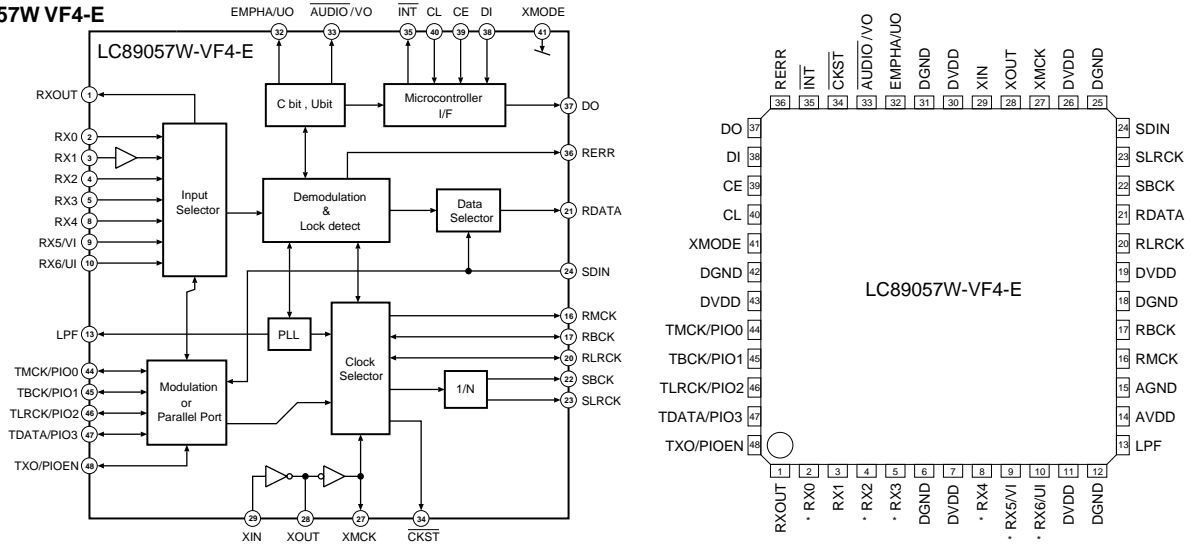

LC89057W

No.	Port name	I/O	Description
1	RXOUT	O	Data Output
2	RX0	I	Digital data Input (TTL)
3	RX1	I	Digital data Input (Coaxial)
4	RX2	I	Digital data Input (TTL)
5	RX3	I	Digital data Input (TTL)
6	DGND		Digital GND
7	DVDD		Digital VDD
8	RX4	I	Digital data Input (TTL)
9	RX5/VI	I	Digital data Input (TTL)
10	RX6/UI	I	Digital data Input (TTL)
11	DVDD		Digital GND for PLL
12	DGND		Digital VDD for PLL
13	LPF	O	Loop filter for PLL
14	AVDD		Analog VDD for PLL
15	AGND		Analog GND for PLL
16	RMCK	O	System clock Output for R (256fs, 512fs, XIN, VCO)
17	RBCK	O/I	Bit clock Output for R (64fs)
18	DGND		Digital GND
19	DVDD		Digital VDD
20	RLRCK	O/I	LR clock Input/Output for R
21	RDATA	O	Serial Audio data Input
22	SBCK	O	Bit clock Output for S (32fs, 64fs, 128fs)
23	SLRCK	O	LR clock Output for S (fs/2, fs, 2fs)
24	SDIN	I	Serial Audio data Input
25	DGND		Digital GND
26	DVDD		Digital VDD
27	XMCK	O	Oscillation amplifier
28	XOUT	O	XOUT
29	XIN	I	XIN or External clock Input (24.576MHz or 12.288MHz)
30	DVDD		Digital VDD
31	DGND		Digital GND
32	EMPHA/UO	I/O	Emphasis Information / U data Output / Set for chip address
33	AUDIO/V O	I/O	Detected non-PCM / V flag Output / Set for chip address
34	CKST	I/O	Clock timing Output / Switch to master or slave for demodulation
35	INT	I/O	Interrupt Output / Switch to Modulation or general-purpose I/O
36	RERR	O	Error Output (PLL lock, data error)
37	DO	O	IF, Read out data Output
38	DI	I	IF, Write data Input
39	CE	I	IF, Chip enable Input
40	CL	I	IF, Clock Input
41	XMODE	I	System reset Input
42	DGND		Digital GND
43	DVDD		Digital VDD
44	TMCK/PIO0	I/O	256fs system-clock Input for modulation / General-purpose I/O input/output
45	TBCK/PIO1	I/O	64fs bit-clock Input for modulation / General-purpose I/O input/output
46	TLRCK/PIO2	I/O	Fs clock Input for modulation / General-purpose I/O input/output
47	TDATA/PIO3	I/O	Serial audio data for modulation / General-purpose I/O input/output
48	TXO/PIOEN	O/I	Modulation data Output / General-purpose I/O enable input

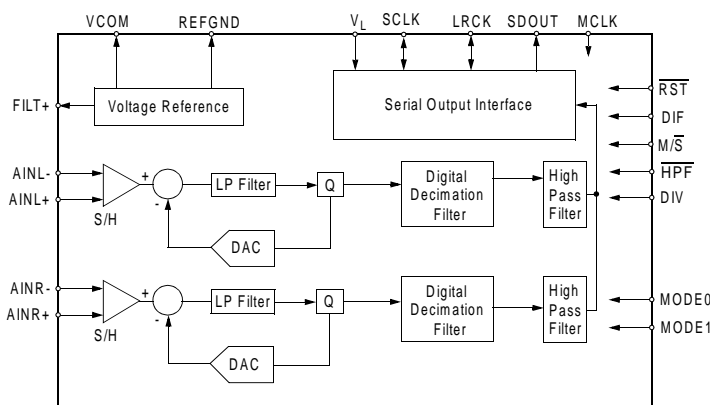
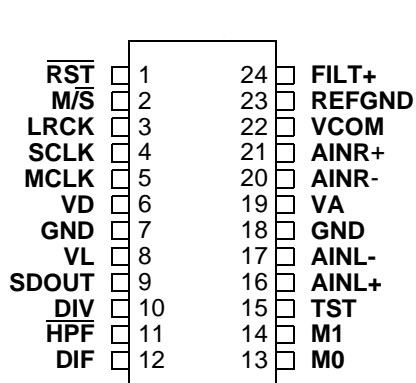

Pin Name	I/O	#	Pin Description
RST	I	1	Reset (Input) - The device enters a low power mode when low.
M/S	I	2	Master/Slave Mode (Input) -In Slave mode, LRCK and SCLK become input. (FIXED LOW)
LRCK	I	3	Left Right Clock (Input) - Determines which channel, Left or Right, is currently active on the serial audio data line. The frequency of the left/right clock must be at the audio sample rate, Fs.
SCLK	I	4	Serial Clock (Input) - Serial clock for the serial audio interface.
MCLK	I	5	Master Clock (Input) - Clock source for the delta-sigma modulator and digital filters. Table 1 illustrates several standard audio sample rates and the required master clock frequency.
VD	I	6	Digital Power (Input) - Positive power supply for the digital section. Refer to the Recommended Operating Conditions for appropriate voltages.
GND	I	7,18	Ground (Input) - Ground reference. Must be connected to analog ground.
VL	I	8	Logic Power (Input) - Determines the required signal level for the digital input/output. Refer to the Recommended Operating Conditions for appropriate voltages.
SDOUT	O	9	Serial Audio Data Output (Output) - Output for two's complement serial audio data.
DIV	I	10	MCLK Divider (Input) - (FIXED LOW)
HPF	I	11	High Pass Filter Enable (Input) - The device includes a high pass filter after the decimator to remove the indeterminate DC offsets introduced by the analog buffer stage and the analog modulator. The first-order high pass filter response characteristics are detailed in the Digital Filter specifications table. The filter response scales linearly with sample rate.
DIF	I	12	Digital Interface Format (Input) - The required relationship between the Left/Right clock, serial clock and serial data is defined by the Digital Interface Format selection. Refer to Figures 8 and 9.
M0	I	13,	Mode Selection (Input) - (FIXED LOW)
M1	I	14	(FIXED LOW)
TST	I	15	Test Pin (Input) - This pin needs to be connected to GND.
AINL+ AINL-	I I	16, 17	Differential Left Channel Analog Input (Input) - Signals are presented differentially to the delta-sigma modulators via the AINL+/- pins. The full scale differential analog input level is specified in the Analog Characteristics Specification table.
VA	I	19	Analog Power (Input) - Positive power supply for the analog section. Refer to the Recommended Operating Conditions for appropriate voltages.
AINR+ AINR-	I I	20, 21	Differential Right Channel Analog Input (Input) -Signals are presented differentially to the delta-sigma modulators via the AINR+/- pins. The full scale differential analog input level is specified in the Analog Characteristics Specification table.
VCOM	O	22	Common Mode Voltage (Output) - Nominally 2.5 volts; can be used to bias the analog input circuitry to the common mode voltage of the CS5361. VCOM is not buffered and the maximum current is 10 uA.
REF_GND	I	23	Reference Ground (Input) - Ground reference for the internal sampling circuits and must be connected to analog ground.
FILT+	O	24	Positive Voltage Reference (Output) - Positive reference voltage for the internal sampling circuits. Requires the capacitive decoupling to GND as shown in the Typical Connection Diagram.

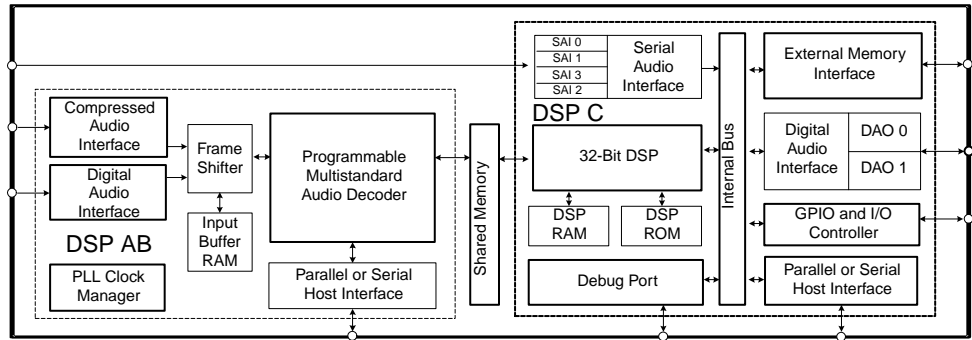

Pin No.	I/O	Function	Description
1	I/O	UHS0, GPIO18	Mode Select Bit 0, General Purpose I/O
2	I/O	UHS1, GPIO19	Mode Select Bit 1, General Purpose I/O
3		INTREQ	Control Port Interrupt Request
4	I	FA1, FSCDIN	Host Address Bit One or SPI Serial Control Data Input
5	I/O	GPIO20	General Purpose I/O
6	I	FA0, FSCCLK	Host Parallel Address Bit Zero or Serial Control Port Clock
7	I/O	FHS2, FSCDIO, FSCDOUT	Mode Select Bit 2 or Serial Control Port Data Input and Output, Parallel Port Type Select
8	I/O	GPIO21	General Purpose I/O
9		FDAT7	DSP AB Bidirectional Data Bus
10		VDD6	2.5V Supply Voltage
11		VSS6	2.5V Ground
12		FHS0, FWR, FDS	Mode Select Bit 0 or Host Write Strobe or Host Data Strobe
13	O	FHS1, FRD, FR/W	Mode Select Bit 1 or Host Parallel Output Enable or Host Parallel R/W
14		FDAT6	DSP AB Bidirectional Data Bus
15	I	FCS	Host Parallel Chip Select, Host Serial SPI Chip Select
16	O	FINTRREQ	Control Port Interrupt Request
17		FDBCK	Reserved
18		FDAT5	DSP AB Bidirectional Data Bus
19		FDAT4	DSP AB Bidirectional Data Bus
20		VDD7	2.5V Supply Voltage
21		VSS7	2.5V Ground
22		FDAT3	DSP AB Bidirectional Data Bus
23		FDBDA	Reserved
24		FDAT2	DSP AB Bidirectional Data Bus
25		DBDA	Debug Data
26		DBCK	Debug Clock
27		FDAT1	DSP AB Bidirectional Data Bus
28		TEST	Reserved
29		FDAT0	DSP AB Bidirectional Data Bus
30	I/O	NV_WE, GPIO16	SRAM Write Enable, General Purpose I/O
31	I/O	NV_OE, GPIO15	SRAM Output Enable, General Purpose I/O
32	I/O	NV_CS, GPIO14	SRAM Chip Select, General Purpose I/O
33		SD_WE	SDRAM Write Enable
34		SD_DATA0, EXTD0	SDRAM Data Bus, SRAM External Data Bus
35		SD_DATA1, EXTD1	SDRAM Data Bus, SRAM External Data Bus
36		SD_DATA2, EXTD2	SDRAM Data Bus, SRAM External Data Bus
37		SD_DATA3, EXTD3	SDRAM Data Bus, SRAM External Data Bus
38		SD_DATA4, EXTD4	SDRAM Data Bus, SRAM External Data Bus
39		SD_DQM0	SDRAM Data Mask 2
40		SD_DATA5, EXTD5	SDRAM Data Bus, SRAM External Data Bus
41		VSSSD4	3.3V SDRAM/SRAM/EPROM Interface Ground
42		VDDSD4	3.3V SDRAM/SRAM/EPROM Interface Supply
43		SD_DATA6, EXTD6	SDRAM Data Bus, SRAM External Data Bus
44		SD_DATA7, EXTD7	SDRAM Data Bus, SRAM External Data Bus
45		SD_DQM1	SDRAM Data Mask 1
46		SD_DATA15, EXTA18	SDRAM Data Bus, SRAM External Address Bus
47		SD_DATA14, EXTA17	SDRAM Data Bus, SRAM External Address Bus
48		NC5	No Connect
49		SD_DATA13, EXTA16	SDRAM Data Bus, SRAM External Address Bus
50		VSSSD3	3.3V SDRAM/SRAM/EPROM Interface Ground
51		VDDSD3	3.3V SDRAM/SRAM/EPROM Interface Supply
52		SD_DATA12, EXTA15	SDRAM Data Bus, SRAM External Address Bus

53		SD_DATA11, EXTA14	SDRAM Data Bus, SRAM External Address Bus
54		SD_DATA10, EXTA13	SDRAM Data Bus, SRAM External Address Bus
55		SD_DATA9, EXTA12	SDRAM Data Bus, SRAM External Address Bus
56		SD_DATA8, EXTA11	SDRAM Data Bus, SRAM External Address Bus
57		VSSSD2	3.3V SDRAM/SRAM/EPROM Interface Ground
58		VDDSD2	3.3V SDRAM/SRAM/EPROM Interface Supply
59	O	SD_CLK_OUT	SDRAM Clock Output
60		SD_ADDR9, EXTA9	SDRAM Address Bus, SRAM External Address Bus
61	I	SD_CLK_IN	SDRAM Re-timing Clock Input
62		SD_ADDR8, EXTA8	SDRAM Address Bus, SRAM External Address Bus
63		SD_ADDR7, EXTA7	SDRAM Address Bus, SRAM External Address Bus
64		SD_CLK_EN	SDRAM Clock Enable
65		SD_ADDR6, EXTA6	SDRAM Address Bus, SRAM External Address Bus
66		SD_ADDR5, EXTA5	SDRAM Address Bus, SRAM External Address Bus
67		SD_ADDR4, EXTA4	SDRAM Address Bus, SRAM External Address Bus
68		SD_CS	SDRAM Chip Select
69		VSSSD1	3.3V SDRAM/SRAM/EPROM Interface Ground
70		VDDSD1	3.3V SDRAM/SRAM/EPROM Interface Supply
71		SD_BA, EXTA19	SDRAM Bank Address Select, SRAM External Address Bus
72		SD_ADDR10, EXTA10	SDRAM Address Bus, SRAM External Address Bus
73		SD_ADDR0, EXTA0	SDRAM Address Bus, SRAM External Address Bus
74		SD_ADDR1, EXTA1	SDRAM Address Bus, SRAM External Address Bus
75		SD_ADDR2, EXTA2	SDRAM Address Bus, SRAM External Address Bus
76		SD_ADDR3, EXTA3	SDRAM Address Bus, SRAM External Address Bus
77		SD_RAS	SDRAM Row Address Strobe
78		SD_CAS	SDRAM Column Address Strobe
79	I/O	SDATAN3, GPIO27	PCM Audio Input Data, General Purpose I/O
80	I/O	SDATAN2, GPIO26	PCM Audio Input Data, General Purpose I/O
81	I/O	SDATAN1, GPIO25	PCM Audio Input Data, General Purpose I/O
82	I/O	SDATAN0, GPIO24	PCM Audio Input Data, General Purpose I/O
83		NC4	No Connect
84		NC3	No Connect
85	I/O	LRCLKN, GPIO23	PCM Audio Input Sample Rate Clock, General Purpose I/O
86	I/O	SCLKN, GPIO22	PCM Audio Input Bit Clock, General Purpose I/O
87	O	LRCLK1	Audio Output Sample Rate Clock
88		NC2	No Connect
89		NC1	No Connect
90		VDD1	2.5V Supply Voltage
91		VSS1	2.5V Ground
92	I/O	AUDATA7, XMT958B, GPIO31	Digital Audio Output 7, S/PDIF Transmitter, General Purpose I/O
93	I/O	AUDATA6, GPIO30	Digital Audio Output 6, General Purpose I/O
94	I/O	AUDATA5, GPIO29	Digital Audio Output 5, General Purpose I/O
95	I/O	HDATA7, GPIO7	DSP C Bidirectional Data Bus, General Purpose I/O
96	I/O	HDATA6, GPIO6	DSP C Bidirectional Data Bus, General Purpose I/O
97	I/O	HDATA5, GPIO5	DSP C Bidirectional Data Bus, General Purpose I/O
98	O	SCLK1	Audio Output Bit Clock

IC19 : CS494001-CQ

99	MCLK	Audio Master Clock	
100	VDD2	2.5V Supply Voltage	
101	VSS2	2.5V Ground	
102	I/O	AUDATA4, GPIO28	Digital Audio Output 4, General Purpose I/O
103	I/O	HDATA4, GPIO4	DSP C Bidirectional Data Bus, General Purpose I/O
104	O	SCLK0	Audio Output Bit Clock
105	I/O	HDATA3, GPIO3	DSP C Bidirectional Data Bus, General Purpose I/O
106	O	AUDATA3, XMT958A	Digital Audio Output 3, S/PDIF Transmitter
107	O	AUDATA2	Digital Audio Output 2
108	O	LRCLK0	Audio Output Sample Rate Clock
109	O	AUDATA1	Digital Audio Output 1
110	O	AUDATA0	Digital Audio Output 0
111	I	CMPCCLK, FSCLKN2	PCM Audio Input Bit Clock
112	I/O	HDATA2, GPIO2	DSP C Bidirectional Data Bus, General Purpose I/O
113		VSS3	2.5V Ground
114		VDD3	2.5V Supply Voltage
115	I/O	HDATA1, GPIO1	DSP C Bidirectional Data Bus, General Purpose I/O
116	I/O	HDATA0, GPIO0	DSP C Bidirectional Data Bus, General Purpose I/O
117	O	CMPREQ, FLRCLKN2	Frame Clock Data Request Out
118	I	CMPCDAT, FSDATAN2	PCM Audio Data Input Number Two
119	I	FLRCLKN1	PCM Audio Input Sample Rate Clock
120	I/O	WR, DS, GPIO10	Host Write Strobe, Host Data Strobe, General Purpose I/O
121	I/O	RD, R/W, GPIO11	Host Parallel Output Enable, Host Parallel R/W, General Purpose I/O
122		PLLVSS	PLL Ground Voltage
123		FILT2	Phase Locked Loop Filter
124		FILT1	Phase-Locked Loop Filter
125		PLLVD	PLL Supply Voltage
126	O	CLKOUT, XTALO	Crystal Oscillator Output
127	I	CLKIN, XTALI	External Clock Input/Crystal Oscillator Input
128		CLKSEL	DSP Clock Select
129	I/O	CS, GPIO9	Host Parallel Chip Select, General Purpose I/O
130	I/O	A0, GPIO13	Host Parallel Address Bit 0, General Purpose I/O
131	I	FSDATAN1	PCM Audio Data Input One
132		VDD4	2.5V Supply Voltage
133		VSS4	2.5V Ground
134	I	FSCLKN1, STCCLK2	PCM Audio Input Bit Clock
135		SCS	Host Serial SPI Chip Select
136	I	SCDIN	SPI Serial Control Data Input
137		VSS5	2.5V Ground
138		VDD5	2.5V Supply Voltage
139	I/O	A1, GPIO12	Host Address Bit 1, General Purpose I/O
140	I/O	SCDOUT, SCDIO	Serial Control Port Data Input and Output
141	I/O	HINBSY, GPIO8	Input Host Message Status, General Purpose I/O
142		SCCLK	Serial Control Port Clock
143	I/O	UHS2, CS_OUT, GPIO17	Mode Select Bit 2, External Serial Memory Chip Select, General Purpose I/O
144	I	RESET	Master Reset Input

IC24/IC25 : TC9499N

○TC9499N/F

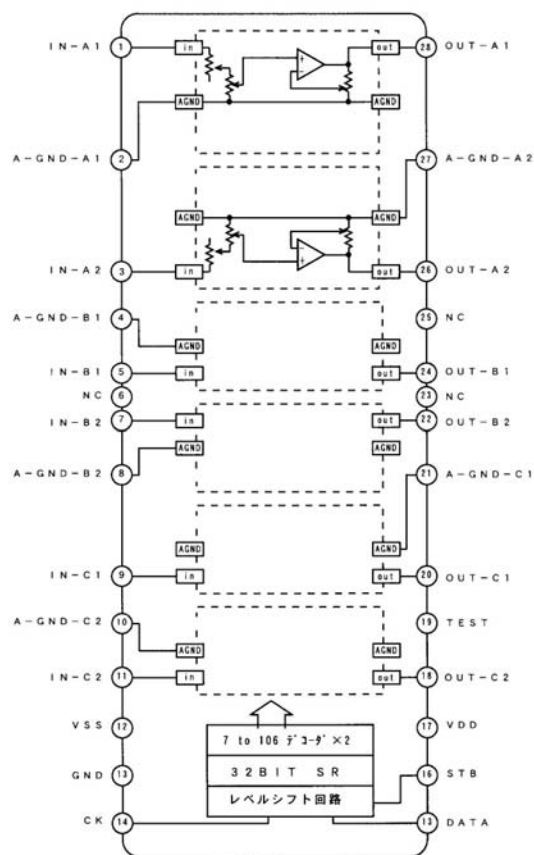

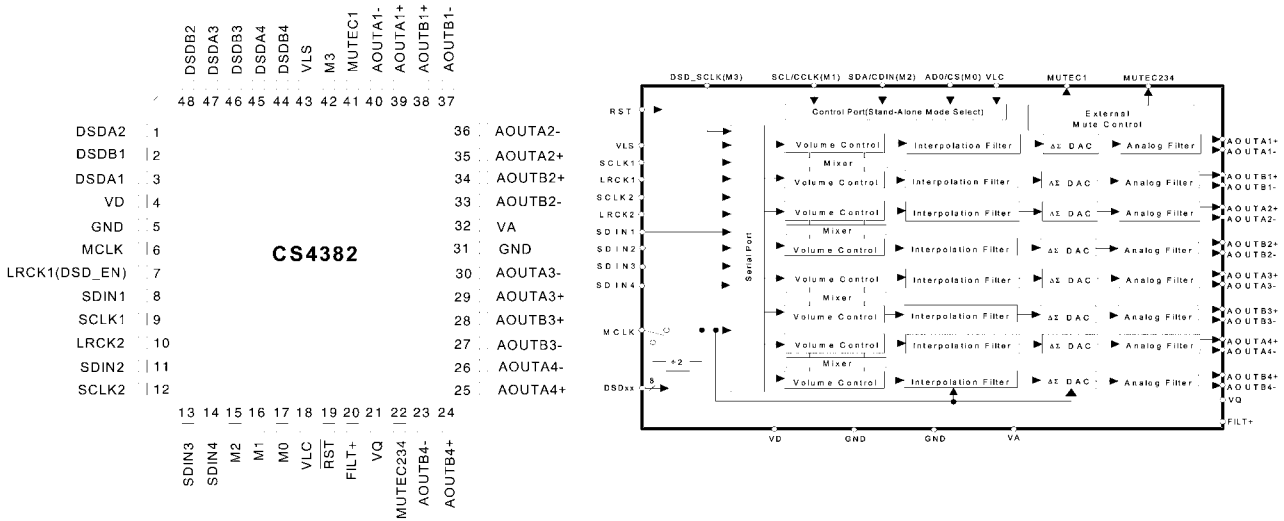

Pin Name	I/O #	Pin #	Description
VD	I	4	Digital Power (Input) - Positive power supply for the digital section. Refer to the Recommended Operating Conditions for appropriate voltages.
GND	I	5	Ground (Input) - Ground reference. Should be connected to analog ground.
MCLK	I	6	Master Clock (Input) - Clock source for the delta-sigma modulator and digital filters. Table 5 illustrates several standard audio sample rates and the required master clock frequency.
LRCK1	I	7	Left Right Clock (Input) - Determines which channel, Left or Right, is currently active on the serial audio data line. The frequency of the left/right clock must be at the audio sample rate, Fs.
LRCK2	I	10	
SDIN1	I	8	Serial Audio Data Input (Input) - Input for two's complement serial audio data.
SDIN2	I	11	
SDIN3	I	13	
SDIN4	I	14	
SCLK1	I	9	Serial Clock (Input) - Serial clock for the serial audio interface.
SCLK2	I	12	
VLC	I	18	Control Port Power (Input) - Determines the required signal level for the control port. Refer to the Recommended Operating Conditions for appropriate voltages.
RST	I	19	Reset (Input) - The device enters a low power mode and all internal registers are reset to their default settings when low.
FILT+	I	20	Positive Voltage Reference (Output) - Positive reference voltage for the internal sampling circuits. Requires the capacitive decoupling to analog ground, as shown in the Typical Connection Diagram.
VQ	I	21	Quiescent Voltage (Output) - Filter connection for internal quiescent voltage. VQ must be capacitively coupled to analog ground, as shown in the Typical Connection Diagram. The nominal voltage level is specified in the Analog Characteristics and Specifications section. VQ presents an appreciable source impedance and any current drawn from this pin will alter device performance. However, VQ can be used to bias the analog circuitry assuming there is no AC signal component and the DC current is less than the maximum specified in the Analog Characteristics and Specifications section.

Pin Name	I/O	#	
MUTEC1	O	41	Mute Control (Output) - The Mute Control pins go high during power-up initialization, reset, muting, power-down or if the master clock to left/right clock frequency ratio is incorrect. These pins are intended to be used as a control for external mute circuits to prevent the clicks and pops that can occur in any single supply system. The use of external mute circuits are not mandatory but may be desired for designs requiring the absolute minimum in extraneous clicks and pops.
MUTEC234	O	22	
AOUTA1 +,-	O	39, 40	Differential Analog Output (Output) - The full scale differential analog output level is specified in the Analog Characteristics specification table.
AOUTB1 +,-	O	38, 37	
AOUTA2 +,-	O	35, 36	
AOUTB2 +,-	O	34, 33	
AOUTA3 +,-	O	29, 30	
AOUTB3 +,-	O	28, 27	
AOUTA4 +,-	O	25, 26	
AOUTB4 +,-	O	24, 23	
VA	I	32	Analog Power (Input) - Positive power supply for the analog section. Refer to the Recommended Operating Conditions for appropriate voltages.
VLS	I	43	Serial Audio Interface Power (Input) - Determines the required signal level for the serial audio interface. Refer to the Recommended Operating Conditions for appropriate voltages.

Stand-Alone Definitions

M0	17	Mode Selection (Input) - Determines the operational mode of the device as detailed in Tables 6 and 7.
M1	16	FIXED GND
M2	15	FIXED GND
M3	42	

DSD Definitions

DSDA1	3	FIXED GND
DSDB1	2	FIXED GND
DSDA2	1	FIXED GND
DSDB2	48	FIXED GND
DSDA3	47	FIXED GND
DSDB3	46	FIXED GND
DSDA4	45	FIXED GND
DSDB4	44	FIXED GND

IC28 : H8S/2398(HD64F2398F20)

Pin	Port mode = 7	I/O	Use	STBY	Name	Port Setting		Note
						Act.	init	
1	PG3	I/O	O	I	BTMOD	L	L	FLASH ROM Address (A18)
2	PG4	I/O	I	I	N.C	-	-	PULL DOWN
3	VSS	I	-	-	VSS	-	-	GND
4	VSSNC	-	NC	-	NC	-	-	GND
5	VCC	I	YES	-	Vcc	-	-	
6	PC0	I/O	O	I	_RSTDAC	L	L	DAC
7	PC1	I/O	O	I	DFS	H	L	DAC&ADC
8	PC2	I/O	O	I	_ATT	L	H	ADC
9	PC3	I/O	O	I	_RSTADC	L	H	ADC
10	VSS	I	-	-	VSS	-	-	GND
11	PC4	I/O	O	I	D_A	-	L	DIR or _ADC sel
12	PC5	I/O	I	I	XSTATE	-	-	DIR
13	PC6	I/O	O	I	_CEDIR	L	L	DIR CHIP ENABLE
14	PC7	I/O	O	I	_XMODE	L	L	DIR RESET
15	PB0	I/O	O	O	IICCLK	-	L	I2C for E2PROM
16	PB1	I/O	I/O	I/O	IICDATA	-	L	I2C for E2PROM
17	PB2	I/O	I	I	_TU_SD	L		Tuned
18	PB3	I/O	I	I	TU_ST	H		Stereo Tune/_MONO
19	VSS	I	-	-	VSS	-	-	GND
20	PB4	I/O	O	I	TU_MUTE	H	H	Tuner MUTE
21	PB5	I/O	O	I	_CE_TU	L	L	Tuner Pack
22	PB6	I/O	O	I	KILL_SBMUTE	L	H	L : Multi SP H : SB SP
23	PB7	I/O	O	I	N.C	-	-	
24	PA0	I/O	O	I	TUDOUT	-	L	Tuner Pack
25	PA1	I/O	O	I	TUCLK	-	L	Tuner Pack
26	PA2	I/O	I	I	TUDIN	-		Tuner Pack
27	PA3	I/O	I	I	RDSDIN	-		Tuner Pack(RDS DATA)
28	VSS	I	-	-	VSS	-	-	GND
29	PA4/_IRQ4	I/O	INT	I	REQ2	L	-	DSP FINTR EQ
30	PA5/_IRQ5	I/O	INT/I	I	DIR_INT			DIR INT OUTPUT
31	PA6/_IRQ6	I/O	INT	I	_P_AMP_FAIL	L	-	Power amp Dectect
32	PA7/_IRQ7	I/O	INT	I	IRQ7	-	-	RDS Clock
33	P67/_IRQ3	I/O	INT	I	REQ1	L	-	DSP INTER Q
34	P66/_IRQ2	I/O	INT	I	RERR	H	-	DIR ERROR
35	VSS	I	-	-	VSS	-	-	GND
36	VSS	I	-	--	VSS	-	-	GND
37	P65/_IRQ1	I/O	INT	INT	WAKEUP	↑	-	STANDBY MODE Release
38	P64/_IRQ0	I/O	INT	I	_P_DOWN	L	-	Power Down Detect
39	VCC	I	YES	-	Vcc	-	-	+5V
40	PE0	I/O	I	I	CONV_SENS	-	-	Video Convert H : Yes L : No
41	PE1	I/O	O	I	_CEEX	L	H	P-Exp(Video)Sel A
42	PE2	I/O	O	I	Y_OSD	H	L	Y/C_OSD_IC_BYPASS
43	PE3	I/O	O	I	CVBS_OSD	H	L	CVBS_OSD_IC_BYPASS
44	VSS	I	-	-	VSS	-	-	GND
45	PE4	I/O	O	I	_CEOSD	L	H	Video Circuit
46	PE5	I/O	I	I	HINBSY	-	-	DSP Busy Signal
47	PE6	I/O	O	I	AFDATA	-	L	Analog Switch DATA
48	PE7	I/O	O	I	AFCLK	-	L	Analog Switch CLOCK
49	PD0	I/O	O	I	CE_TCA	H	L	Analog Switch TC9273
50	PD1	I/O	O	I	CE_TCB	H	L	Analog Switch TC9262/9264
51	PD2	I/O	O	I	MULTI MUTE	H	H	MULTI ROOM MUTE
52	PD3	I/O	O	I	SWMUTE	H	H	SUB W MUTE
53	VSS	I	-	-	VSS	-	-	GND
54	PD4	I/O	O	I	CNTMUTE	H	H	CENTER SP MUTE
55	PD5	I/O	O	I	SBMUTE	H	H	SRR B MUTE
56	PD6	I/O	O	I	SL/SRMUTE	H	H	SL SR MUTE
57	PD7	I/O	O	I	L/RMUTE	H	H	FRONT L R MUTE
58	VCC	I	YES	I	Vcc	-	-	+5V
59	P30/TxD0	I/O	SO	I	DSPDOUT			DSP DIR Control Data OUT
60	P31/TxD1	I/O	SO	SO	TXD		H	Flash WR need Pull Up
61	P32/RxD0	I/O	SI	I	DSPDIN			DSP DIR Control Data IN
62	P33/RxD1	I/O	SI	SI	RXD		-	Flash WR need Pull UpReset release is H.
63	P34/SCK0	I/O	SC	I	DSPCLK			DSP DIR Control CLOCK
64	P35/SCK1	I/O	O	I	_CEFL	L	L	FL Driver chip sel
65	VSS	I	-	-	VSS	-	-	GND
66	P60/_DREQ0	I/O	O	I	VOLDATA	-	L	Volume IC DATA
67	VSS	I	-	-	VSS	-	-	GND
68	VSS	I	-	-	VSS	-	-	GND
69	P61/_TEND0	I/O	O	I	VOLCLK	-	L	Volume IC CLOCK
70	P62/_DREQ1	I/O	O	I	CE_VOLA	H	L	Volume IC Chip Sel A
71	P63/_TEND1	I/O	O	I	CE_VOLB	H	L	Volume IC Chip Sel B

IC28 : H8S/2398(HD64F2398F20)

Pin	Port mode = 7	I/O	Use	STBY	Name	Port Setting		Note
						Act.	init	
72	P27/PO7/TIOCB5/TMO1	I/O	O	I	FLRA_ON	H	L	SPK A SELECT
73	P26/PO6/TIOCA5/TMO0	I/O	O	I	FLRB_ON	H	L	SPK B SELECT
74	P25/PO5/TIOCB4/TMC11	I/O	O	I	SURR_ON	H	L	SURR/CNT/SB SPK ON
75	P24/PO4/TIOCA4/TMR11	I/O	O	I	HEAT	H	L	Power Amp±B_L_Sel
76	P23/PO3/TIOCD3/TMC10	I/O	I	I	_HEAT_DET	H	-	Power Amp Heat sink TempDetect
77	P22/PO2/TIOCC3/TMR10	I/O	O	I	_STANDBY	L	L	Standby Power
78	P21/PO1/TIOCB3	I/O	I	I	_HP_DET	L	-	HP Jack Detect
79	P20/PO0/TIOCA3	I/O	O	I	HP_ON	H	L	HEAD PHONE ON
80	VCL	I	-	I	VCL	-	-	
81	_RES	I	YES	I	_RST	L	-	Reset
82	NMI	I	NO	I	NMI	-	-	Fix H (At the time of the un-use)
83	_STBY	I	NO	I	_STBY	L	H	FixH
84	VCC	I	YES	I	Vcc	-	-	+5V
85	XTAL	I	YES	I	XTAL	-	-	Xtal(20M)
86	EXTAL	I	YES	I	EXTAL	-	-	Xtal(20M)
87	VSS	I	-	-	VSS	-	-	GND
88	PF7/	I/O	I	I	SEL-	-	-	Front Select. Encoder
89	VCC	I	YES	-	Vcc	-	-	+5V
90	PF6	I/O	I	I	SEL+	-	-	Front Select. Encoder
91	PF5	I/O	O	O	_STBY LED	L	H	Standby LED On
92	PF4	I/O	O	I	_RSFL	L	L	Front FL Driver
93	PF3	I/O	I	I	VOL-	-	-	Front Vol. Encoder
94	PF2	I/O	I	I	VOL+	-	-	Front Vol. Encoder
95	PF1	I/O	I	I	CTS	-	-	UART
96	PF0	I/O	O	O	RTS	-	H	UART
97	P50/TxD2/_IRQ4	I/O	SO	I	OSDDATA	-	-	Front FL & Video(OSD), Y/C & Sepa 4094, SAA, AK
98	P51/RxD2/_IRQ5	I	I	I	N.C	-	-	PULL DOWN
99	VSS	I	-	-	VSS	-	-	GND
100	VSS	I	-	-	VSS	-	-	GND
101	P52/SCK2/_IRQ6	I/O	SC	I	OSDCLK	-	-	Front FL & Video(OSD), Y/C & Sepa 4094, SAA, AK
102	P53/_ADTRG/_IRQ7	I/O	O	I	_RSTFL	L	L	Reset FL Driver
103	AVCC	I	-	-	AVCC	-	-	+5V
104	Vref	I	-	-	VREF	-	-	+5V
105	P40/AN0	I	AD	AD	KEY0	-	-	Front Key
106	P41/AN1	I	AD	AD	KEY1	-	-	Front Key
107	P42/AN2	I	AD	AD	KEY2	-	-	Front Key
108	P43/AN3	I	AD	AD	_5V_DOWN	-	-	Detect 5V
109	P44/AN4	I	AD	AD	P_LINE_FAIL	-	-	Emergency Protection
110	P45/AN5	I	AD	AD	MODE	-	-	CPU mode
111	P46/AN6/DA0	I	I	I	_OVFL	H	-	Peak Indicator
112	P47/AN7/DA1	I	AD	AD	TV_AUTO	H	L	TV Video Detect
113	AVSS	I	-	-	VSS	-	-	GND
114	VSS	I	-	-	VSS	-	-	GND
115	P17/PO15/TIOCB2/TCLKD	I/O	T_OUT	I	M_RC_OUT	-	L	RC BUS MULTI OUT
116	P16/PO14/TIOCA2	I/O	T_OUT	I	RC_OUT	-	L	RC BUS output
117	P15/PO13/TIOCB1/TCLKC	I/O	I	I	M_RC_IN	L	H	Multi RC5 IN Detect Signal
118	P14/PO12/TIOCA1	I/O	T_IN	I	VSYNC	↑	-	V-sync Det. & Change OSD
119	P13/PO11/TIOCD0/TCLKB	I/O	O	O	KILLIR	H	L	Kill to IR input signal.
120	P12/PO10/TIOCC0/TCLKA	I/O	O	I	DC_OUT1	L	H	DC Triger
121	P11/PO9/TIOCB0/_DACK1	I/O	O	I	SB_O	H	L	SB Relay Control H : SB ON L : SB OFF
122	P10/PO8/TIOCA0/_DACK0	I/O	T_IN	T_IN	RC_IN	↓↑	-	IR In for RC-5 Input polarity is reverse to SR7300.
123	MD0	I	YES	YES	MD0	-	-	+5V
124	MD1	I	YES	YES	MD1	-	-	Fix H
125	MD2	I	YES	YES	MD2	-	-	Normal :H, Boot :L
126	PG0	I/O	O	I	_FCS	L	H	DSP CHIP ENABLE
127	PG1	I/O	O	I	_RSTDSP	L	L	DSP
128	PG2	I/O	O	I	_SCS	L	H	DSP CHIP ENABLE

IC81 : NJU3430FG1

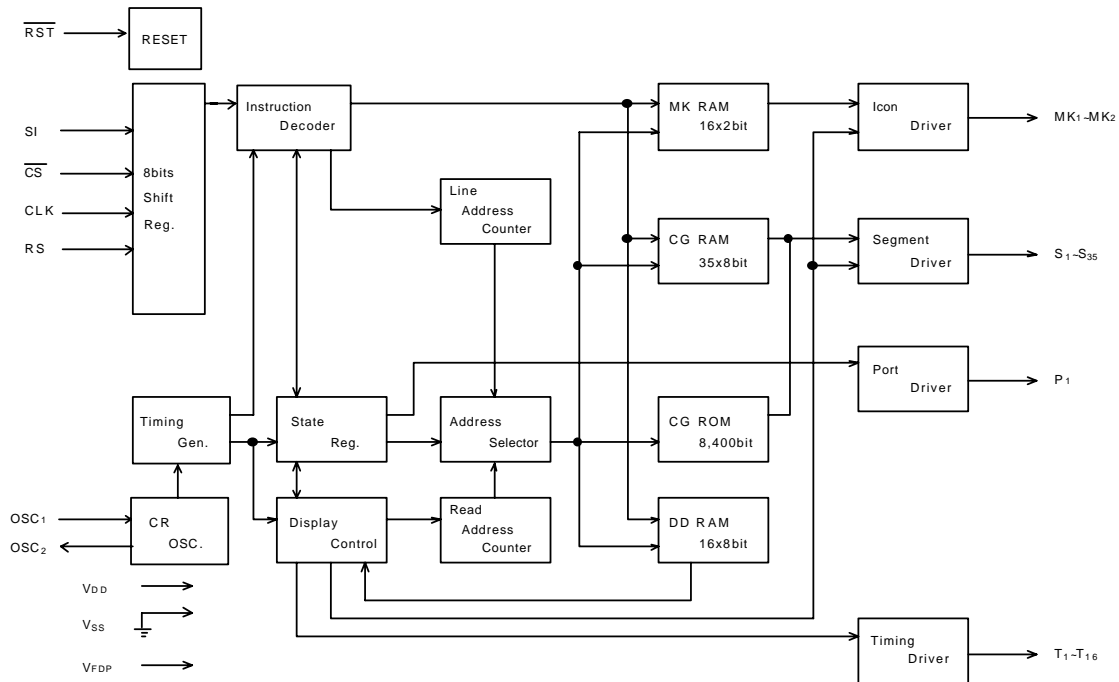

No.	SYMBOL	I/O	F U N C T I O N
57	VDD	-	Power Source : VDD=+3.0 to 5.5V
49	VSS	-	GND : VSS=0V
48	VFDP	-	VFD Driving Power Source VDD-20V to VDD-45V
50	OSC1	I	CR Oscillation Terminal External R and C connect to these terminals. (Target fOSC=360kHz)
51	OSC2	O	
54	CLK	I	Serial Clock Input Terminal The serial data input synchronizing the rise edge of this terminal.
53	\overline{CS}	I	Chip Select Terminal When the CS terminal is "H" the serial data input is not available.
55	SI	I	Serial Data Input Terminal The data input is MSB first.
56	RS	I	Register Selection Signal Input Terminal RS="0" : Instruction Register RS="1" : Data Register
52	\overline{RST}	I	Reset Terminal RST="L" : Reset -Each Address : (00)H -Each RAM Data : Unfixed -Display Digits : 16-digit -Contrast Control : 8/16 Duty -All Display Off -All Outputs are "L"
61 to 64, 1 to 31	S1 to S35	O	Segment Output Terminals (Internal Pull-down Resistance)
32 to 47	T1 to T16	O	Timing Output Terminals (Internal Pull-down Resistance)
60 59	MK1 MK2	O	Icon Output Terminals (Internal Pull-down Resistance)
58	P1	O	Output Port Terminal This terminal is suitable for LED.

CMOS level output that outputs a biphasic-mark encoded (S/PDIF) IEC60958 signal or digital audio data which is capable of carrying two channels of PCM digital audio. *OUTPUT*

AUDATA4, GPIO28 — Digital Audio Output 4, General Purpose I/O
PCM digital-audio data output. This pin can act as a general-purpose input or output that can be individually configured and controlled by DSPC. *BIDIRECTIONAL - Default: OUTPUT*

AUDATA5, GPIO29 — Digital Audio Output 5, General Purpose I/O
PCM digital-audio data output. This pin can act as a general-purpose input or output that can be individually configured and controlled by DSPC. *BIDIRECTIONAL - Default: OUTPUT*

AUDATA6, GPIO30 — Digital Audio Output 6, General Purpose I/O
PCM digital-audio data output. This pin can act as a general-purpose input or output that can be individually configured and controlled by DSPC. *BIDIRECTIONAL - Default: OUTPUT*

AUDATA7, XMT958B, GPIO31 — Digital Audio Output 7, S/PDIF Transmitter, General Purpose I/O
CMOS level output that contains a biphasic-mark encoded (S/PDIF) IEC60958 signal or digital audio data which is capable of carrying two channels of PCM digital audio. This pin can also act as a general-purpose input or output that can be individually configured and controlled by DSPC. *BIDIRECTIONAL - Default: OUTPUT*

DBCK — Debug Clock
Must be tied high to 3.3k ohm resistor. *INPUT*

DBDA — Debug Data
Must be tied high to 3.3k ohm resistor. *BIDIRECTIONAL - Default: INPUT*

SLCKN, GPIO22 — PCM Audio Input Bit Clock, General Purpose I/O
Digital-audio bit clock that is an input. SCLKN operates asynchronously from all other DSPAB clocks. The active edge of SCLKN can be programmed by the DSP. This pin can act as a general-purpose input or output that can be individually configured and controlled by DSPC. *BIDIRECTIONAL - Default: INPUT*

LRCLKN, GPIO23 — PCM Audio Input Sample Rate Clock, General Purpose I/O
Digital-audio frame clock input. LRCLKN operates asynchronously from all other DSPAB clocks. The polarity of LRCLKN for a particular subframe can be programmed by the DSP. This pin can act as a general-purpose input or output that can be individually configured and controlled by DSPC. *BIDIRECTIONAL - Default: INPUT*

SDATAN0, GPIO24 — PCM Audio Input Data, General Purpose I/O
Digital-audio PCM data input. This pin can act as a general-purpose input or output that can be individually configured and controlled by DSPC. *BIDIRECTIONAL - Default: INPUT*

SDATAN1, GPIO25 — PCM Audio Input Data, General Purpose I/O

Digital-audio PCM data input. This pin can act as a general-purpose input or output that can be individually configured and controlled by DSPC. *BIDIRECTIONAL - Default: INPUT*

SDATAN2, GPIO26 — PCM Audio Input Data, General Purpose I/O
Digital-audio PCM data input. This pin can act as a general-purpose input or output that can be individually configured and controlled by DSPC. *BIDIRECTIONAL - Default: INPUT*

SDATAN3, GPIO27 — PCM Audio Input Data, General Purpose I/O
Digital-audio PCM data input. This pin can act as a general-purpose input or output that can be individually configured and controlled by DSPC. *BIDIRECTIONAL - Default: INPUT*

SCS — Host Serial SPI Chip Select
SPI mode active-low chip-select input signal. *INPUT*

SCCLK — Serial Control Port Clock
This pin serves as the serial SPI clock input. *INPUT*

SCDIN — SPI Serial Control Data Input
In SPI mode this pin serves as the data input pin. *INPUT*

SCDOUT, SCDIO — Serial Control Port Data Input and Output
In SPI mode this pin serves as the data output pin. *BIDIRECTIONAL - Default: OUTPUT in SPI mode*

INTREQ — Control Port Interrupt Request
Open-drain interrupt-request output. This pin is driven low to indicate that DSPC has outgoing control data and should be serviced by the host. *OPEN DRAIN I/O - Requires 3.3K Ohm Pull-Up*

IC78 : LC74781

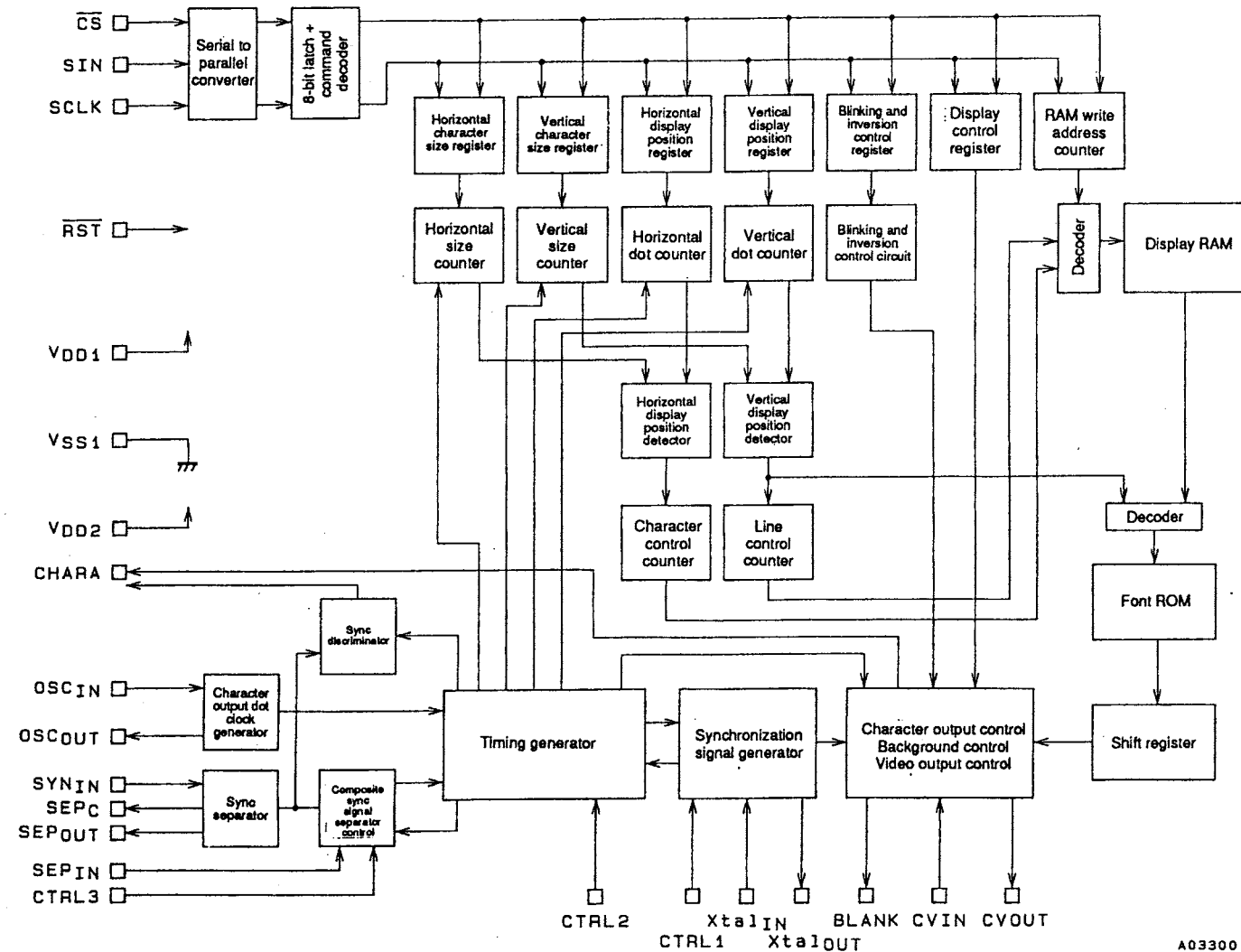

IC78 : LC74781

Pin Functions

Pin No.	Symbol	Function	Description
1	V _{SS1}	Ground	Ground connection (digital system ground)
2	Xtal _{IN}	Crystal oscillator connection	Used to connect the crystal oscillator and capacitor used to generate the internal synchronization signal, or to input an external clock (2fsc or 4fsc).
3	Xtal _{OUT}		
4	CTRL1	Crystal oscillator input switching	Switches between external clock input mode and crystal oscillator mode. Low = crystal oscillator mode, high = external clock mode
5	BLANK	Blanking output	Outputs the blank signal (the OR of the character and border signals). (Outputs a composite sync signal when MOD0 is high.) Outputs the crystal oscillator clock during reset (when the RST pin is low), but can be set up to not output this signal by microprocessor command.
6	OSC _{IN}	LC oscillator connection	Connections for the coil and capacitor that form the oscillator that generates the character output dot clock.
7	OSC _{OUT}		
8	CHARA	Character output	Outputs the character signal. (Functions as the external synchronization signal discrimination signal output pin when MOD0 is high, and outputs the state of the judgment as to whether the external synchronization signal is present or not. Outputs a high level when the synchronization signal is present.) Outputs the dot clock (LC oscillator) during reset, but can be set up to not output this signal by microprocessor command.
9	$\overline{\text{CS}}$	Enable input	Serial data input enable input. Serial data input is enabled when low. A pull-up resistor is built in (hysteresis input).
10	SCLK	Clock input	Serial data input clock input. A pull-up resistor is built in (hysteresis input).
11	SIN	Data input	Serial data input. A pull-up resistor is built in (hysteresis input).
12	V _{DD2}	Power supply	Composite video signal level adjustment power supply pin (analog system power supply).
13	CV _{OUT}	Video signal output	Composite video signal output
14	NC		Must be either connected to ground or left open.
15	CV _{IN}	Video signal input	Composite video signal input
16	V _{DD1}	Power supply	Power supply (+5 V: digital system power supply)
17	SYN _{IN}	Sync separator circuit input	Video signal input for the built-in sync separator circuit (Used for either horizontal synchronization signal or composite sync signal input when the built-in sync separator circuit is not used.)
18	SEP _C	Sync separator circuit bias voltage	Built-in sync separator circuit bias voltage monitor pin
19	SEP _{OUT}	Composite sync signal output	Built-in sync separator circuit composite sync signal output. (When MOD1 is high, outputs a high level during internal synchronization and a low level during external synchronization.) (Outputs the SYN _{IN} input signal when the internal sync separator circuit is not used.)
20	SEP _{IN}	Vertical synchronization signal input	Inputs a vertical synchronization signal created by integrating the SEP _{OUT} pin output signal. An integrator must be attached at the SEP _{OUT} pin. This pin must be tied to V _{DD1} if unused.
21	CTRL2	NTSC/PAL-M switching input	The setting indicated by this pin takes priority in switching between the NTSC, PAL, PAL-M and PAL-N formats. A low level selects NTSC after a reset. The microprocessor command NTSC, PAL, PAL-M, or PAL-N setting is valid. High = PAL-M format.
22	CTRL3	SEP _{IN} input control	Controls whether or not the VSYNC signal is input to the SEP _{IN} input. Low = $\overline{\text{VSYNC}}$ input, high = VSYNC not input.
23	RST	Reset input	System reset input. A pull-up resistor is built in (hysteresis input).
24	V _{DD1}	Power supply (+5 V)	Power supply (+5 V: digital system power supply)

8. EXPLODED VIEW AND PARTS LIST

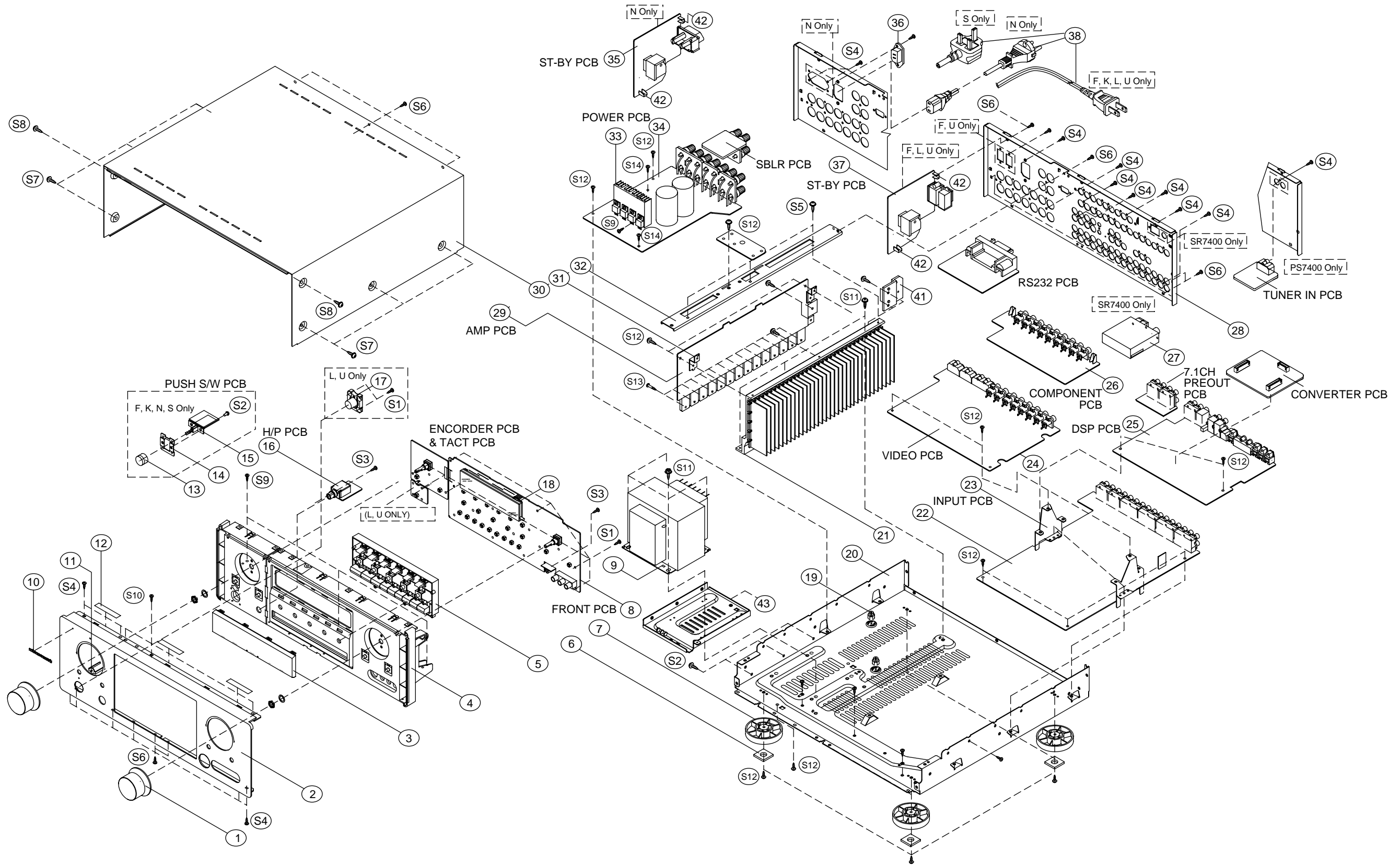

POS. NO	VERS. COLOR	PART NO. (FOR EUR)	PART NO. (MJI)	DESCRIPTION		
1	/N1S	28AW154030	28AW154030	KNOB	MASTER KNOB (SILVER)	HGK1A090XA
1	/N1B/U1B	28AW154010	28AW154010	KNOB	MASTER KNOB (BLACK)	HGK1A090YA
1	/F/K/L/S	nsp	28AW154020	KNOB	MASTER KNOB (GOLD)	HGK1A090ZA
2	/F	nsp	37AW248130	PANEL	FRONT AL PANEL (F GOLD)	CKM2A134SC24
2	/L	nsp	37AW248120	PANEL	FRONT AL PANEL (L GOLD)	CKM2A134TC24
2	/N1B	37AW248010	37AW248010	PANEL	FRONT AL PANEL (BLACK)	CKM2A134UC23
2	/U1B	nsp	37AW248020	PANEL	FRONT AL PANEL (U BLACK)	CKM2A134TC23
2	/K/S	nsp	37AW248110	PANEL	FRONT AL PANEL (GOLD)	CKM2A134UC24
2	/N1S	37AW248210	37AW248210	PANEL	FRONT AL PANEL (SILVER)	CKM2A134UC40
3	/F	nsp	27AW158040	WINDOW	WINDOW (PS)	CGU1A306W
3	/N1S	27AW158210	27AW158210	WINDOW	WINDOW (SR SILVER)	CGU1A306Y
3	/K/L/N1B/S/U	27AW158010	27AW158010	WINDOW	WINDOW (SR)	CGU1A306Z
4	/N1S	37AW105220	37AW105220	CHASSIS	FRONT MOLD CHASSIS (SILVER)	CGW1A358R6XG13
4	/F/K/L/S	nsp	37AW105120	CHASSIS	FRONT MOLD CHASSIS (GOLD)	CGW1A358RFXD4
4	/N1B/U1B	37AW105020	37AW105020	CHASSIS	FRONT MOLD CHASSIS (BLACK)	CGW1A358XK92
5	/F/K/L/S	nsp	27AW270110	BUTTON	FUNCTION BUTTON (GOLD)	CBT1A876RFD4
5	/N1B/U1B	27AW270010	27AW270010	BUTTON	FUNCTION BUTTON (BLACK)	CBT1A876K92
5	/N1S	27AW270210	27AW270210	BUTTON	FUNCTION BUTTON (SILVER)	CBT1A876R6G13
6		nsp	nsp	CUSHION		KHG1A050
7	/F/K/L/N1B/S/U	243W057010	243W057010	LEG	LEG	CKL2A042H11
7	/N1S	243W057210	243W057210	LEG	LEG SILVER	CKL2A042H46
8	/F	nsp	nsp	PCB ASSY	PS7400/F1	COP11655E
8	/K	nsp	nsp	PCB ASSY	SR7400/K1	COP11655D
8	/L	nsp	nsp	PCB ASSY	SR7400/L1	COP11655I
8	/N	nsp	nsp	PCB ASSY	SR7400/N1	COP11655B
8	/S	nsp	nsp	PCB ASSY	SR7400/S1	COP11655F
8	/U	nsp	nsp	PCB ASSY	SR7400/U1	COP11655C
▲	9/K	nsp	*TS002100R	MAINS TRANSF.	SR7400/K1	CLT5W0122H
▲	9/L	nsp	*TS002130R	MAINS TRANSF.	SR7400/L1	CLT5W0122S
▲	9/N/S	*TS002110R	*TS002110R	MAINS TRANSF.	SR7400/N1	CLT5W0122E
▲	9/U	nsp	*TS002120R	MAINS TRANSF.	SR7400/U1	CLT5W0122U
10	/F/K/L/N1B/S/U	24AW251010	24AW251010	BADGE	NEW MZ BADGE	CGB1A117
10	/N1S	24AW251020	24AW251020	BADGE	NEW MZ BADGE SILVER	CGB1A117G
11		27AW355010	27AW355010	LENS	STANDBY LENS	CGL1A216
12		nsp	nsp	TAPE		KHS1A032
13	/N1B	27AW270040	27AW270040	KNOB	POWER SW BUTTON (BLACK)	CBC1A146K92
13	/N1S	27AW270240	27AW270240	KNOB	POWER SW BUTTON (SILVER)	CBC1A146R6G13
13	/F/K/S	nsp	27AW270140	KNOB	POWER SW BUTTON (GOLD)	CBC1A146RFD4
14	/F/K/N/S	nsp	nsp	BRACKET		CMD1A493
15	/F/K/N/S	*SP000850R	*SP000850R	SWITCH	CN JPP1197CSA64	KSH1A001ZV
16		*YT003160R	*YT003160R	TERMINAL		CJJ2E020Z
17	/L	nsp	27AW270130	KNOB	POWER SW BUTTON TACT (GOLD)	CBT1A877RFD4
17	/U1B	nsp	27AW270030	KNOB	POWER SW BUTTON TACT (BLACK)	CBT1A877K92
18		nsp	nsp	BRACKET		CMD1A374
19		nsp	nsp	HOLDER		CHE1A030
20		nsp	nsp	CHASSIS		CUA1A230
21		nsp	nsp	HEATSINK	SR7400	CMY1A220ZA
22	/F	nsp	nsp	PCB ASSY	PS7400/F1	COP11657E
22	/K/L/N/S/U	nsp	nsp	PCB ASSY	SR7400	COP11657B
23		nsp	nsp	BRACKET		CMD1A492
24	/F/L/U	nsp	nsp	PCB ASSY	SR7400/U1	COP11661C
24	/K/N/S	nsp	nsp	PCB ASSY	SR7400/N1	COP11661B
25	/F	nsp	nsp	PCB ASSY	PS7400/F1	COP11658E
25	/K	nsp	nsp	PCB ASSY	SR7400/K1	COP11658D
25	/L/U	nsp	nsp	PCB ASSY	SR7400/U1	COP11658C
25	/N	nsp	nsp	PCB ASSY	SR7400/N1	COP11658B
25	/S	nsp	nsp	PCB ASSY	SR7400/S1	COP11658F
26		nsp	nsp	PCB ASSY	SR7400/N1	COP11660B
27	/K	nsp	*AV000330R	TUNER	KST-MB014MA1-8A	CNVKSTMB014MA1A
27	/L/U	nsp	*AV000350R	TUNER	KST-MB014MA0-8	CNVKSTMB014MA08
27	/N/S	*AV000340R	*AV000340R	TUNER	KST-MB114LA1-8	CNVKSTMB114LA18

NOTE : *nsp* PART IS LISTED FOR REFERENCE ONLY, MARANTZ WILL NOT SUPPLY THESE PARTS.

POS. NO	VERS. COLOR	PART NO. (FOR EUR)	PART NO. (MJI)	DESCRIPTION		
28	/F	nsp	nsp	PANEL	REAR PANEL F1N	CKF4A273Z
28	/K	nsp	nsp	PANEL	REAR PANEL K1G	CKF3A273Z
28	/L	nsp	nsp	PANEL	REAR PANEL L1G	CKF2A273X
28	/N1S	nsp	nsp	PANEL	REAR PANEL N1S	CKF1A273Y
28	/N1B	nsp	nsp	PANEL	REAR PANEL N1B	CKF1A273Z
28	/S	nsp	nsp	PANEL	REAR PANEL S1G	CKF1A273X
28	/U	nsp	nsp	PANEL	REAR PANEL U1B	CKF2A273Z
29		nsp	nsp	PCB ASSY	SR7400	COP11656B
31		nsp	nsp	BRACKET		CMD1A490
32		nsp	nsp	BRACKET		CMD1A491K92
33		nsp	nsp	HEATSINK		CMY1A207
34	/F/L/U	nsp	nsp	PCB ASSY	SR7400/U1	COP11659C
34	/K/N/S	nsp	nsp	PCB ASSY	SR7400/N1	COP11659B
▲	36	*YJ002690R	*YJ002690R	INLET	R-301(187-2P)	HJJ8A001Z
41		nsp	nsp	HEATSINK	SR7400	CMY1A225
42		nsp	nsp	BRACKET		CMD1A387
43		nsp	nsp	BRACKET		CMD1A510
JW15		*YU001540R	*YU001540R	FPC	16PIN 270MM PITCH 1MM	CWC1B4A16A270A
JW25		*YU001550R	*YU001550R	FPC	19PIN 80MM PITCH 1MM	CWC1B4A19A080B
JW27		*YU001570R	*YU001570R	FPC	17PIN 80MM PITCH 1.25MM	CWC1C4A17B080B
JW34	/K/L/U	nsp	*YU001560R	FPC	15PIN 160MM PITCH 1.25MM	CWC1C4A15B160B
JW35	/N/S	*YU001580R	*YU001580R	FPC	17PIN 160MM PITCH 1.25MM	CWC1C4A17B160B
JW36		*YU001520R	*YU001520R	FPC	11PIN 80MM PITCH 1MM	CWC1B4A11A080A
JW38		*YU001530R	*YU001530R	FPC	13PIN 450MM PITCH 1MM	CWC1B4A13A450A
JW42		*YU001500R	*YU001500R	FPC	7PIN 50MM PITCH 1MM	CWC1B4A07A050A
JW50		*YU001510R	*YU001510R	FPC	11PIN 50MM PITCH 1MM	CWC1B4A11A050B
		*FC500030R	*FC500030R	FERRITE CORE	29X7.7X19	CLZ9W003Z
▲ F801	/F/L/U	nsp	*FS001080R	FUSE		KBA2C1002TLEY
▲ F801	/K/N/S	*FS001090R	*FS001090R	FUSE	5A/250V(EUR)	KBA2C5000TLEY
				PACKING		
	/F	nsp	37AW851110	USER GUIDE	USER GUIDE SR7400 F	CQX1A886Z
	/K/S	nsp	37AW851350	USER GUIDE	USER GUIDE SR7400 K S	CQX1A885Z
	/L	nsp	37AW851360	USER GUIDE	USER GUIDE SR7400 L	
	/N	37AW851310	37AW851310	USER GUIDE	USER GUIDE SR7400 N	CQX1A883Z
	/U	nsp	37AW851250	USER GUIDE	USER GUIDE SR7400 U	CQX1A884Z
		ZK36AW0010	ZK36AW0010	UNIT KIT	REMOTE CONTROLLER RC1400	HARTSR7400
38	/F	nsp	*ZC000350R	MAINS CORD	12A/125V	HJA2J076Z
38	/K	nsp	*ZC000330R	MAINS CORD	10A/250V	HJA2N075Z
38	/L	nsp	*ZC000370R	MAINS CORD		
38	/N	*ZC000320R	*ZC000320R	MAINS CORD	2WIRE 10A/250V	CJA2B054Z
38	/S	nsp	*ZC000340R	MAINS CORD	10A/250V	HJA2E077Z
38	/U	nsp	*ZC000310R	MAINS CORD	032508/12	CJA2A070Z
				NOT STANDARD SPARE PART		
	/F	nsp	37AW801030	PACKING CASE	PACKING CASE PS7400	CPG1A720S
	/K/L/S	nsp	37AW801020	PACKING CASE	PACKING CASE SR7400 WO CO	CPG1A720T
	/N/U	nsp	37AW801010	PACKING CASE	PACKING CASE SR7400	CPG1A720U
	/N	nsp	37AW805010	MASS CARTON	MASTER PKG SR7400 N	CPG1A746Y
		nsp	27AW809010	CUSHION		CPS1A649
		nsp	27AW809020	CUSHION		CPS1A650
30	/F/K/L/S	nsp	27AW257110	LID	TOP COVER (GOLD)	CKC1A139K118
30	/N1S	nsp	27AW257210	LID	TOP COVER (SILVER)	CKC1A139G14
30	/N1B/U	nsp	27AW257010	LID	TOP COVER (BLACK)	CKC1A139K117

NOTE : "nsp" PART IS LISTED FOR REFERENCE ONLY, MARANTZ WILL NOT SUPPLY THESE PARTS.

9. POWER AMPLIFIER ADJUSTMENT

Idling Current Alignment

1. Each of the measurement points are provided with the two test points. Set a digital Voltage meter to DC voltage input, connect the meter to the test points at both contact points.
2. After the setup above, turn on the main switch and heat up the amplifier about 10 minutes.
3. Adjust variable resistors (VR41, VR42...VR71) according to the digital voltmeter readings. The target setting value is 4.9 mV +/- 0.05 mV for each channels.

Settings : Master Volume --- Minimum

Speaker out --- No Load

Top lid --- OPEN

Channel	Alignment Point	Measurement Point
Front L	VR41	CN41
Center	VR61	CN61
Front R	VR51	CN51
Surr. L	VR42	CN42
Surr. R	VR52	CN52
Surr. Back L	VR62	CN62
Surr. Back R	VR71	CN71

Time Table of Idling Current Rise

After Turning ON	Measurement Voltage (CN**)
5 min.	4.5 mV
10 min.	4.9 mV
20 min.	5.5 mV
30 min.	6.2 mV
40 min.	6.8 mV
60 min.	7.0 mV

10. SERVICE MODE

Microprocessor (IC28), DSP(IC20)Version and FLD Segment Check Mode.

- While the power is on, **S-DIRECT**, **TAPE** and **SELECT** buttons simultaneously more than 3 seconds.
The FL display shows "SERVICE MODE"for 2 seconds then shows the model name.

S	E	R	V	I	C	E		M	O	D	E	
---	---	---	---	---	---	---	--	---	---	---	---	--

			S	R	7	4	0	0				
--	--	--	---	---	---	---	---	---	--	--	--	--

- Press **SELECT** button, The software version of the microprocessor (IC28) is displayed in the format below.

V	0	3	1	0	2	7		I	U			

[Year] [Month] [Date] [Dest.]

(Dest.:Destination)

- Press **SELECT** button again, The software Serial Number that is wirtten in the factory is displayed.

M	Z	x	x	x	x	x	x	x	x	x	x	x
---	---	---	---	---	---	---	---	---	---	---	---	---

- Press **SELECT** button again, The software Type Number is displayed.

S	O	F	T		T	Y	P	E			x	x
---	---	---	---	--	---	---	---	---	--	--	---	---

(XX is displayed in Hex)

- Press **SELECT** button again, The Code Group Type Number is displayed.

C	O	D	E		T	Y	P	E	x	x	x	x
---	---	---	---	--	---	---	---	---	---	---	---	---

(XXXX is displayed in Hex)

- Press **SELECT** button again, The left half, right half and center of the label area in the FLD light on and off each other.
- Press **SELECT** button again, The segments of the character area in the FLD flick in checker pattern.
- Press **SELECT** button again, All the FL segments turns off.
- Press **SELECT** button again. Every time **SELECT** button is pressed, DSP code is indicated in turn from NO.1 to NO.10.

C	D	0	1		0	1	0	2	0	1	0	1

[No.] [Dev.] [SIG] [TYP] [Ver.]

No.:DSP CODE ID Dev.:Device ID SIG:CODE SIG ID

TYP:CODE TYP ID Ver.:Version

- Press **SELECT** button again to quit this mode.

10. SERVICE MODE

Microprocessor (IC28), DSP(IC20) の Version 表示及び FL 点燈を確認するモードです。

- セットの電源を入れます。 **S-DIRECT**, **TAPE**, **SELECT** のボタンを同時に約 3 秒以上押します。
"SERVICE MODE" と表示が出ます。更に約 2 秒後に機種名が表示されます。

S	E	R	V	I	C	E		M	O	D	E	
---	---	---	---	---	---	---	--	---	---	---	---	--

			S	R	7	4	0	0				
--	--	--	---	---	---	---	---	---	--	--	--	--

- SELECT** ボタンを押します。マイコン (IC28) のバージョンが次のように表示されます。

V	0	3	1	0	2	7		1	U			

[Year] [Month] [Date] [Dest.]

(Dest.: 仕向け)

- SELECT** ボタンを押します。工場で書き込み済みの Software Serial No. が表示されます

M	Z	x	x	x	x	x	x	x	x	x	x	x
---	---	---	---	---	---	---	---	---	---	---	---	---

- SELECT** ボタンを押します。マイコン (IC28) の Software Type が表示されます

S	O	F	T		T	Y	P	E			x	x
---	---	---	---	--	---	---	---	---	--	--	---	---

(XX:Hex 数字表示)

- SELECT** ボタンを押します。Code Group Type が表示されます

C	O	D	E		T	Y	P	E	x	x	x	x
---	---	---	---	--	---	---	---	---	---	---	---	---

(XXXX:Hex 数字表示)

- SELECT** ボタンを押します。FL 表示の右、左、中央部分が交互に点燈を繰り返します。
- SELECT** ボタンを押します。FL の Character 部分が点滅します。
- SELECT** ボタンを押します。FL が全消灯します
- SELECT** ボタンを押します。 **SELECT** ボタンを押す度に DSP Code ID が NO.1 から NO.10 まで順に表示されます。

C	D	0	1		0	1	0	2	0	1	0	1

[No.] [Dev.] [SIG] [TYP] [Ver.]

No.:DSP CODE ID Dev.:Device ID SIG:CODE SIG ID

TYP:CODE TYP IDVer.:Version

- SELECT** ボタンを押します。サービスモードは解除されません。

11. SYSTEM ERROR

When the microcomputer detects a trouble, the following information is displayed on the FLD.

- After the error contents indication, Surround Mode is initialized and returned Factory mode.
- The contents of the ERROR indication are the followings.

1. Trouble in DSP.

If communication with DSP is troubled more than 2 seconds

C	H	E	C	K		D	S	P				
---	---	---	---	---	--	---	---	---	--	--	--	--

Indication is keep and sound is mute.

2. Trouble in DSP Code.

The trouble of DSP Code was found.

C	H	E	C	K		D	S	P		R	O	M
---	---	---	---	---	--	---	---	---	--	---	---	---

3. Trouble in ADC.

When ADC input was chosen and CAL signal continued High about 2 seconds after the ADC Calibration start.

C	H	E	C	K		A	D	C				
---	---	---	---	---	--	---	---	---	--	--	--	--

4. Trouble in EEPROM

If data from EEPROM does not match.

C	H	E	C	K		E	2	P				
---	---	---	---	---	--	---	---	---	--	--	--	--

5. Trouble in EEPROM IF

If communication with EEPROM is troubled more than 2 seconds.

C	H	E	C	K		E	2	P		I	F	
---	---	---	---	---	--	---	---	---	--	---	---	--

6. Trouble in RS-232C.

If communication of Panja with RS232C is troubled more than 2 seconds.

C	H	E	C	K		2	3	2	C			
---	---	---	---	---	--	---	---	---	---	--	--	--

7. Trouble in 5V Supply

If 5V supply to DATA DIR is troubled.

C	H	E	C	K		P	O	W	5			
---	---	---	---	---	--	---	---	---	---	--	--	--

8. Trouble in Protection

CPU turns off the speaker output

P	R	O	T	E	C	T						
---	---	---	---	---	---	---	--	--	--	--	--	--

11. SYSTEM ERROR

製品内部での異常発生時に処理、表示を行います。主に各 Device との通信異常を検出します。

- ERROR 表示後、Surround Mode は初期化され工場出荷の状態に戻ります。
- ERROR 表示の内容は下記です。

1. DSP 異常検出表示。

DSP との通信上の不具合を約 2 秒検出した時。

C	H	E	C	K		D	S	P				
---	---	---	---	---	--	---	---	---	--	--	--	--

表示状態はそのまま音声は Mute 状態

2. DSP Code 異常検出表示。

DSP Code の異常を検出した時。

C	H	E	C	K		D	S	P		R	O	M
---	---	---	---	---	--	---	---	---	--	---	---	---

3. ADC 異常検出表示。

ADC 入力を選択した場合に ADC Calibration 開始後、CAL 信号が約 2 秒以上 High を持続した時。

C	H	E	C	K		A	D	C				
---	---	---	---	---	--	---	---	---	--	--	--	--

4. EEPROM 異常検出表示。

EEP-ROM Data の不整合を検出した時。

C	H	E	C	K		E	2	P				
---	---	---	---	---	--	---	---	---	--	--	--	--

5. EEPROM IF 異常検出表示。

EEP-ROM との通信不具合が約 2 秒以上生じた時。

C	H	E	C	K		E	2	P		I	F	
---	---	---	---	---	--	---	---	---	--	---	---	--

6. RS-232C 異常検出表示。

Panja 通信時に RS-232C との通信不具合を約 2 秒以上検出した時。

C	H	E	C	K		2	3	2	C			
---	---	---	---	---	--	---	---	---	---	--	--	--

7. 5V 異常検出表示。

DATA DIR. の異常を検出した時。

C	H	E	C	K		P	O	W	5			
---	---	---	---	---	--	---	---	---	---	--	--	--

8. Protection 信号異常検出表示。

Speaker から出力を止めます。

P	R	O	T	E	C	T						
---	---	---	---	---	---	---	--	--	--	--	--	--

13. ELECTRICAL PARTS LIST

ASSIGNMENT OF COMMON PARTS CODES.

RESISTORS

R***: 1) GD05 × × × 140, Carbon film fixed resistor, ±5% 1/4W

R***: 2) GD05 × × × 160, Carbon film fixed resistor, ±5% 1/6W

① — Resistance value

Examples ;

① Resistance value

0.1 Ω 001 10 Ω 100 1 kΩ 102 100 kΩ 104
 0.5 Ω 005 18 Ω 180 2.7 kΩ 272 680 kΩ 684
 1 Ω 010 100 Ω 101 10 kΩ 103 1 MΩ 105
 6.8 Ω 068 390 Ω 391 22 kΩ 223 4.7 MΩ 475

Note : Please distinguish 1/4W from 1/6W by the shape of parts used actually.

CAPACITORS

C***: CERAMIC CAP.

3) DD1 × × × × 370, Ceramic capacitor
 Disc type
 Temp.coeff.P350 ~ N1000, 50V
 ② — Capacity value
 ③ — Tolerance

Examples ;

② Tolerance (Capacity deviation)

±0.25 pF 0
 ±0.5 pF 1
 ±5% 5

* Tolerance of COMMON PARTS handled here are as follows :

0.5 pF ~ 5 pF ±0.25 pF
 6 pF ~ 10 pF ±0.5 pF
 12 pF ~ 560 pF ±5%

③ Capacity value

0.5 pF 005 3 pF 030 100 pF 101
 1 pF 010 10 pF 100 220 pF 221
 1.5 pF 015 47 pF 470 560 pF 561

C*** : CERAMIC CAP.

4) DK16 × × × × 300, High dielectric constant ceramic capacitor
 Disc type
 Temp.chara. 2B4, 50V
 ④ — Capacity value

Examples ;

④ Capacity value

100 pF 101 1000 pF 102 10000 pF 103
 470 pF 471 2200 pF 222

C*** : 5) ELECTROLY CAP. ($\frac{\square}{\square}$), 6) FILM CAP. ($\frac{\square}{\square}$)

5) EA × × × × × 10, Electrolytic capacitor
 One-way lead type, Tolerance ±20%
 ⑤ — Working voltage
 ⑥ — Capacity value

Examples ;

⑤ Capacity value

0.1 μF 104 4.7 μF 475 100 μF 107
 0.33 μF 334 10 μF 106 330 μF 337
 1 μF 105 22 μF 226 1100 μF 118
 2200 μF 228

⑥ Working voltage

6.3V 006 25V 025
 10V 010 35V 035
 16V 016 50V 050

6) DF15 × × × × 350 — Plastic film capacitor
 DF15 × × × × 310 — One-way type, Mylar ±5% 50V
 DF16 × × × × 310 — Plastic film capacitor
 One-way type, Mylar ±10% 50V
 ⑦ — Capacity value

Examples ;

⑦ Capacity value

0.001 μF (1000 pF) 102 0.1 μF 104
 0.0018 μF 182 0.56 μF 564
 0.01 μF 103 1 μF 105
 0.015 μF 153

NOTE : 1) The above CODES (R***, R***, C***, C*** and C***) are omitted on the schematic diagram in some case.

2) On the occasion, be confirmed the common parts on the parts list.

3) Refer to "Common Parts List" for the other common parts (RI05, DD4, DK4).

NOTE ON SAFETY FOR FUSIBLE RESISTOR :

The suppliers and their type numbers of fusible resistors are as follows;

1. KOA Corporation

Part No. (MJI)	Type No. (KOA)	Description
NH05 × × × 140	RF25S × × × × ΩJ	(±5% 1/4W)
NH05 × × × 120	RF50S × × × × ΩJ	(±5% 1/2W)
NH85 × × × 110	RF73B2A × × × × ΩJ	(±5% 1/10W)
NH95 × × × 140	RF73B2E × × × × ΩJ	(±5% 1/4W)

* Resistance value Resistance value (0.1 Ω – 10 kΩ)

2. Matsushita Electronic Components Co., Ltd

Part No. (MJI)	Type No. (MEC)	Description
NF05 × × × 140	ERD-2FCJ × × ×	(±5% 1/4W)
RF05 × × × 140		
NF02 × × × 140	ERD-2FCG × × ×	(±2% 1/4W)
RF02 × × × 140		

* Resistance value * Resistance value

Examples ;

* Resistance value

0.1 Ω 001 10 Ω 100 1 kΩ 102 100 kΩ 104
 0.5 Ω 005 18 Ω 180 2.7 kΩ 272 680 kΩ 684
 1 Ω 010 100 Ω 101 10 kΩ 103 1 MΩ 105
 6.8 Ω 068 390 Ω 391 22 kΩ 223 4.7 MΩ 475



ABBREVIATION AND MARKS

ANT. : ANTENNA	BATT. : BATTERY
CAP. : CAPACITOR	CER. : CERAMIC
CONN. : CONNECTING	DIG. : DIGITAL
HP : HEADPHONE	MIC. : MICROPHONE
μ-PRO : MICROPROCESSOR	REC. : RECORDING
RES. : RESISTOR	SPK : SPEAKER
SW : SWITCH	TRANSF : TRANSFORMER
TRIM. : TRIMMING	TRS. : TRANSISTOR
VAR. : VARIABLE	X'TAL : CRYSTAL

NOTE ON FUSE :

Regarding to all parts of parts code **FS20xxx2xx**, replace only with Wickmann-Werke GmbH, Type 372 non glass type fuse.

NOTE ON SAFETY :

Symbol  Fire or electrical shock hazard. Only original parts should be used to replaced any part marked with symbol . Any other component substitution (other than original type), may increase risk of fire or electrical shock hazard.

安全上の注意 :



 がついている部品は、安全上重要な部品です。必ず指定されている部品番号の部品を使用して下さい。

POS. NO	VERS. COLOR	PART NO. (FOR EUR)	PART NO. (MJJ)	DESCRIPTION		
AMP PCB (CUP11656Z)						
BN23		nsp	nsp	CONN. CORD		CWZSR7400BN23
BN24		nsp	nsp	CONN. CORD		CWZSR7400BN24
BN25		nsp	nsp	CONN. CORD		CWB1B905180EN
BN68		nsp	nsp	CONN. CORD		CWZSR7400BN68
BN83		nsp	nsp	CONN. CORD		CWZSR7400BN83
C401		nsp	OA10605020	ELECT. CAP.	10µF 50V	HCEA1HH100T
C402		nsp	OA10605020	ELECT. CAP.	10µF 50V	HCEA1HH100T
C403		nsp	nsp	CER. CAP.	330pF 50V KB	CCKT1H331KB
C404		nsp	nsp	CER. CAP.	330pF 50V KB	CCKT1H331KB
C405		nsp	nsp	CER. CAP.	10pF 50V DC	CCCT1H100DC
C406		nsp	nsp	CER. CAP.	10pF 50V DC	CCCT1H100DC
C407		*OF100350R	*OF100350R	FILM CAP	2200pF 50V J	HCQ1H222JZT
C408		*OF100350R	*OF100350R	FILM CAP	2200pF 50V J	HCQ1H222JZT
C409		nsp	OA22605020	ELECT. CAP.	22µF 50V	HCEA1HH220T
C410		nsp	OA22605020	ELECT. CAP.	22µF 50V	HCEA1HH220T
C411		nsp	OA10710020	ELECT. CAP.	100µF 100V	HCEA2AH101E
C412		nsp	OA10710020	ELECT. CAP.	100µF 100V	HCEA2AH101E
C413		nsp	OA10710020	ELECT. CAP.	100µF 100V	HCEA2AH101E
C414		nsp	OA10710020	ELECT. CAP.	100µF 100V	HCEA2AH101E
C419		nsp	OA10705020	ELECT. CAP.	100µF 50V	HCEA1HH101T
C420		nsp	OA10705020	ELECT. CAP.	100µF 50V	HCEA1HH101T
C421		nsp	OA10701620	ELECT. CAP.	100µF 16V	HCEA1CH101T
C422		nsp	OA10701620	ELECT. CAP.	100µF 16V	HCEA1CH101T
C501		nsp	OA10605020	ELECT. CAP.	10µF 50V	HCEA1HH100T
C502		nsp	OA10605020	ELECT. CAP.	10µF 50V	HCEA1HH100T
C503		nsp	nsp	CER. CAP.	330pF 50V KB	CCKT1H331KB
C504		nsp	nsp	CER. CAP.	330pF 50V KB	CCKT1H331KB
C505		nsp	nsp	CER. CAP.	10pF 50V DC	CCCT1H100DC
C506		nsp	nsp	CER. CAP.	10pF 50V DC	CCCT1H100DC
C507		*OF100350R	*OF100350R	FILM CAP	2200pF 50V J	HCQ1H222JZT
C508		*OF100350R	*OF100350R	FILM CAP	2200pF 50V J	HCQ1H222JZT
C509		nsp	OA22605020	ELECT. CAP.	22µF 50V	HCEA1HH220T
C510		nsp	OA22605020	ELECT. CAP.	22µF 50V	HCEA1HH220T
C511		nsp	OA10710020	ELECT. CAP.	100µF 100V	HCEA2AH101E
C512		nsp	OA10710020	ELECT. CAP.	100µF 100V	HCEA2AH101E
C513		nsp	OA10710020	ELECT. CAP.	100µF 100V	HCEA2AH101E
C514		nsp	OA10710020	ELECT. CAP.	100µF 100V	HCEA2AH101E
C519		nsp	OA10705020	ELECT. CAP.	100µF 50V	HCEA1HH101T
C520		nsp	OA10705020	ELECT. CAP.	100µF 50V	HCEA1HH101T
C521		nsp	OA10701620	ELECT. CAP.	100µF 16V	HCEA1CH101T
C522		nsp	OA10701620	ELECT. CAP.	100µF 16V	HCEA1CH101T
C601		nsp	OA10605020	ELECT. CAP.	10µF 50V	HCEA1HH100T
C602		nsp	OA10605020	ELECT. CAP.	10µF 50V	HCEA1HH100T
C603		nsp	nsp	CER. CAP.	330pF 50V KB	CCKT1H331KB
C604		nsp	nsp	CER. CAP.	330pF 50V KB	CCKT1H331KB
C605		nsp	nsp	CER. CAP.	10pF 50V DC	CCCT1H100DC
C606		nsp	nsp	CER. CAP.	10pF 50V DC	CCCT1H100DC
C607		*OF100350R	*OF100350R	FILM CAP	2200pF 50V J	HCQ1H222JZT
C608		*OF100350R	*OF100350R	FILM CAP	2200pF 50V J	HCQ1H222JZT
C609		nsp	OA22605020	ELECT. CAP.	22µF 50V	HCEA1HH220T
C610		nsp	OA22605020	ELECT. CAP.	22µF 50V	HCEA1HH220T
C611		nsp	OA10710020	ELECT. CAP.	100µF 100V	HCEA2AH101E
C612		nsp	OA10710020	ELECT. CAP.	100µF 100V	HCEA2AH101E
C613		nsp	OA10710020	ELECT. CAP.	100µF 100V	HCEA2AH101E
C614		nsp	OA10710020	ELECT. CAP.	100µF 100V	HCEA2AH101E
C619		nsp	OA10705020	ELECT. CAP.	100µF 50V	HCEA1HH101T

NOTE : "nsp" PART IS LISTED FOR REFERENCE ONLY, MARANTZ WILL NOT SUPPLY THESE PARTS.

POS. NO	VERS. COLOR	PART NO. (FOR EUR)	PART NO. (MJI)	DESCRIPTION		
C620		nsp	OA10705020	ELECT. CAP.	100µF 50V	HCEA1HH101T
C621		nsp	OA10701620	ELECT. CAP.	100µF 16V	HCEA1CH101T
C622		nsp	OA10701620	ELECT. CAP.	100µF 16V	HCEA1CH101T
C701		nsp	OA10605020	ELECT. CAP.	10µF 50V	HCEA1HH100T
C703		nsp	nsp	CER. CAP.	330pF 50V KB	CCKT1H331KB
C706		nsp	nsp	CER. CAP.	10pF 50V DC	CCCT1H100DC
C707		*OF100350R	*OF100350R	FILM CAP	2200pF 50V J	HCQI1H222JZT
C709		nsp	OA22605020	ELECT. CAP.	22µF 50V	HCEA1HH220T
C711		nsp	OA10710020	ELECT. CAP.	100µF 100V	HCEA2AH101E
C713		nsp	OA10710020	ELECT. CAP.	100µF 100V	HCEA2AH101E
C719		nsp	OA10705020	ELECT. CAP.	100µF 50V	HCEA1HH101T
C721		nsp	OA10701620	ELECT. CAP.	100µF 16V	HCEA1CH101T
C722		nsp	OA10701620	ELECT. CAP.	100µF 16V	HCEA1CH101T
C801		nsp	OA47505020	ELECT. CAP.	4.7µF 50V	HCEA1HH4R7T
C802		nsp	nsp	CER. CAP.	0.01µF 50V ZF	CCKT1H103ZF
C803		nsp	nsp	CER. CAP.	0.01µF 50V ZF	CCKT1H103ZF
C804		nsp	OA47605020	ELECT. CAP.	47µF 50V	HCEA1HH470T
C805		nsp	OA47405020	ELECT. CAP.	0.47µF 50V	HCEA1HHR47T
C807		nsp	nsp	CER. CAP.	0.01µF 50V ZF	CCKT1H103ZF
C808		nsp	nsp	CER. CAP.	0.01µF 50V ZF	CCKT1H103ZF
C809		nsp	nsp	CER. CAP.	4700pF 50V KB	CCKT1H472ZF
C810		OF15104040	OF15104040	FILM CAP	0.1µF 50V J	HCQI1H104JZT
C811		OF15104040	OF15104040	FILM CAP	0.1µF 50V J	HCQI1H104JZT
CN41		nsp	nsp	JACK	MOLEX 5267-02A	KJP02GA01ZM
CN42		nsp	nsp	JACK	MOLEX 5267-02A	KJP02GA01ZM
CN51		nsp	nsp	JACK	MOLEX 5267-02A	KJP02GA01ZM
CN52		nsp	nsp	JACK	MOLEX 5267-02A	KJP02GA01ZM
CN61		nsp	nsp	JACK	MOLEX 5267-02A	KJP02GA01ZM
CN62		nsp	nsp	JACK	MOLEX 5267-02A	KJP02GA01ZM
CN71		nsp	nsp	JACK	MOLEX 5267-02A	KJP02GA01ZM
CN73		nsp	nsp	JACK	A3963WV2-6P	CJP06GA148ZW
CN81		nsp	nsp	JACK		KJP02GA19ZM
D401		nsp	HD20015210	DIODE	1SS133T-77	HVD1SS133MT
D402		nsp	HD20015210	DIODE	1SS133T-77	HVD1SS133MT
D403		nsp	HD20015210	DIODE	1SS133T-77	HVD1SS133MT
D404		nsp	HD20015210	DIODE	1SS133T-77	HVD1SS133MT
D405		nsp	HD20015210	DIODE	1SS133T-77	HVD1SS133MT
D406		nsp	HD20015210	DIODE	1SS133T-77	HVD1SS133MT
D407		nsp	HD20015210	DIODE	1SS133T-77	HVD1SS133MT
D408		nsp	HD20015210	DIODE	1SS133T-77	HVD1SS133MT
D409		*HD302180R	*HD302180R	ZENER DIODE	3.9V 1/2W	HVDMTZJ3.9BT
D410		*HD302180R	*HD302180R	ZENER DIODE	3.9V 1/2W	HVDMTZJ3.9BT
D411		*HD302180R	*HD302180R	ZENER DIODE	3.9V 1/2W	HVDMTZJ3.9BT
D412		*HD302180R	*HD302180R	ZENER DIODE	3.9V 1/2W	HVDMTZJ3.9BT
D413		nsp	HD20015210	DIODE	1SS133T-77	HVD1SS133MT
D414		nsp	HD20015210	DIODE	1SS133T-77	HVD1SS133MT
D415		nsp	HD20015210	DIODE	1SS133T-77	HVD1SS133MT
D416		nsp	HD20015210	DIODE	1SS133T-77	HVD1SS133MT
D501		nsp	HD20015210	DIODE	1SS133T-77	HVD1SS133MT
D502		nsp	HD20015210	DIODE	1SS133T-77	HVD1SS133MT
D503		nsp	HD20015210	DIODE	1SS133T-77	HVD1SS133MT
D504		nsp	HD20015210	DIODE	1SS133T-77	HVD1SS133MT
D505		nsp	HD20015210	DIODE	1SS133T-77	HVD1SS133MT
D506		nsp	HD20015210	DIODE	1SS133T-77	HVD1SS133MT
D507		nsp	HD20015210	DIODE	1SS133T-77	HVD1SS133MT
D508		nsp	HD20015210	DIODE	1SS133T-77	HVD1SS133MT
D509		*HD302180R	*HD302180R	ZENER DIODE	3.9V 1/2W	HVDMTZJ3.9BT

NOTE : *nsp* PART IS LISTED FOR REFERENCE ONLY, MARANTZ WILL NOT SUPPLY THESE PARTS.

POS. NO	VERS. COLOR	PART NO. (FOR EUR)	PART NO. (MJ)	DESCRIPTION		
D510		*HD302180R	*HD302180R	ZENER DIODE	3.9V 1/2W	HVDMTZJ3.9BT
D511		*HD302180R	*HD302180R	ZENER DIODE	3.9V 1/2W	HVDMTZJ3.9BT
D512		*HD302180R	*HD302180R	ZENER DIODE	3.9V 1/2W	HVDMTZJ3.9BT
D513		nsp	HD20015210	DIODE	1SS133T-77	HVD1SS133MT
D514		nsp	HD20015210	DIODE	1SS133T-77	HVD1SS133MT
D515		nsp	HD20015210	DIODE	1SS133T-77	HVD1SS133MT
D516		nsp	HD20015210	DIODE	1SS133T-77	HVD1SS133MT
D601		nsp	HD20015210	DIODE	1SS133T-77	HVD1SS133MT
D602		nsp	HD20015210	DIODE	1SS133T-77	HVD1SS133MT
D603		nsp	HD20015210	DIODE	1SS133T-77	HVD1SS133MT
D604		nsp	HD20015210	DIODE	1SS133T-77	HVD1SS133MT
D605		nsp	HD20015210	DIODE	1SS133T-77	HVD1SS133MT
D606		nsp	HD20015210	DIODE	1SS133T-77	HVD1SS133MT
D607		nsp	HD20015210	DIODE	1SS133T-77	HVD1SS133MT
D608		nsp	HD20015210	DIODE	1SS133T-77	HVD1SS133MT
D609		*HD302180R	*HD302180R	ZENER DIODE	3.9V 1/2W	HVDMTZJ3.9BT
D610		*HD302180R	*HD302180R	ZENER DIODE	3.9V 1/2W	HVDMTZJ3.9BT
D611		*HD302180R	*HD302180R	ZENER DIODE	3.9V 1/2W	HVDMTZJ3.9BT
D612		*HD302180R	*HD302180R	ZENER DIODE	3.9V 1/2W	HVDMTZJ3.9BT
D613		nsp	HD20015210	DIODE	1SS133T-77	HVD1SS133MT
D614		nsp	HD20015210	DIODE	1SS133T-77	HVD1SS133MT
D615		nsp	HD20015210	DIODE	1SS133T-77	HVD1SS133MT
D616		nsp	HD20015210	DIODE	1SS133T-77	HVD1SS133MT
D701		nsp	HD20015210	DIODE	1SS133T-77	HVD1SS133MT
D703		nsp	HD20015210	DIODE	1SS133T-77	HVD1SS133MT
D705		nsp	HD20015210	DIODE	1SS133T-77	HVD1SS133MT
D707		nsp	HD20015210	DIODE	1SS133T-77	HVD1SS133MT
D709		*HD302180R	*HD302180R	ZENER DIODE	3.9V 1/2W	HVDMTZJ3.9BT
D710		*HD302180R	*HD302180R	ZENER DIODE	3.9V 1/2W	HVDMTZJ3.9BT
D713		nsp	HD20015210	DIODE	1SS133T-77	HVD1SS133MT
D715		nsp	HD20015210	DIODE	1SS133T-77	HVD1SS133MT
 D801		*HE200250R	*HE200250R	DIODE	US GBJ1504	HVDGBJ1504
IC41		HC10053090	HC10053090	IC	NJM2068DD	HVINJM2068DD
IC51		HC10053090	HC10053090	IC	NJM2068DD	HVINJM2068DD
IC61		HC10053090	HC10053090	IC	NJM2068DD	HVINJM2068DD
IC71		HC10053090	HC10053090	IC	NJM2068DD	HVINJM2068DD
IC81		HC10042050	HC10042050	IC	HK	HVITA7317P
J200						
{		nsp	nsp	JUMPER	SN95/PB5 , 0.6	C3A206
J335						
Q403		*HT600010R	*HT600010R	TRS.	KTA1266YT	HVTKTA1266YT
Q404		*HT600010R	*HT600010R	TRS.	KTA1266YT	HVTKTA1266YT
Q405		*HT800050R	*HT800050R	TRS.	KTC3198YT	HVTKTC3198YT
Q406		*HT800050R	*HT800050R	TRS.	KTC3198YT	HVTKTC3198YT
Q407		*HT600020R	*HT600020R	TRS.	KTA1268GR	HVTKTA1268GRT
Q408		*HT600020R	*HT600020R	TRS.	KTA1268GR	HVTKTA1268GRT
Q409		*HT600020R	*HT600020R	TRS.	KTA1268GR	HVTKTA1268GRT
Q410		*HT600020R	*HT600020R	TRS.	KTA1268GR	HVTKTA1268GRT
Q411		*HT800060R	*HT800060R	TRS.	KTC3200GR	HVTKTC3200GRT
Q412		*HT800060R	*HT800060R	TRS.	KTC3200GR	HVTKTC3200GRT
Q413		*HT800060R	*HT800060R	TRS.	KTC3200GR	HVTKTC3200GRT
Q414		*HT800060R	*HT800060R	TRS.	KTC3200GR	HVTKTC3200GRT
Q415		*HT600030R	*HT600030R	TRS.	KTA1024YT	HVTKTA1024YT
Q416		*HT600030R	*HT600030R	TRS.	KTA1024YT	HVTKTA1024YT
Q417		*HT800090R	*HT800090R	TRS.	KTC3206YA	HVTKTC3206YAT
Q418		*HT800090R	*HT800090R	TRS.	KTC3206YA	HVTKTC3206YAT
 Q419		HC20002080	HC20002080	IC	SAP17NLFNO.552	BVISAP17N

NOTE : "nsp" PART IS LISTED FOR REFERENCE ONLY, MARANTZ WILL NOT SUPPLY THESE PARTS.

POS. NO	VERS. COLOR	PART NO. (FOR EUR)	PART NO. (MJI)	DESCRIPTION		
▲ Q420		HC20002080	HC20002080	IC	SAP17NLFNO.552	BVISAP17N
▲ Q421		HC20001080	HC20001080	IC	SAP17PLFNO.552	BVISAP17P
▲ Q422		HC20001080	HC20001080	IC	SAP17PLFNO.552	BVISAP17P
Q423		*HT800060R	*HT800060R	TRS.	KTC3200GR	HVTKTC3200GRT
Q424		*HT800060R	*HT800060R	TRS.	KTC3200GR	HVTKTC3200GRT
Q503		*HT600010R	*HT600010R	TRS.	KTA1266YT	HVTKTA1266YT
Q504		*HT600010R	*HT600010R	TRS.	KTA1266YT	HVTKTA1266YT
Q505		*HT800050R	*HT800050R	TRS.	KTC3198YT	HVTKTC3198YT
Q506		*HT800050R	*HT800050R	TRS.	KTC3198YT	HVTKTC3198YT
Q507		*HT600020R	*HT600020R	TRS.	KTA1268GR	HVTKTA1268GRT
Q508		*HT600020R	*HT600020R	TRS.	KTA1268GR	HVTKTA1268GRT
Q509		*HT600020R	*HT600020R	TRS.	KTA1268GR	HVTKTA1268GRT
Q510		*HT600020R	*HT600020R	TRS.	KTA1268GR	HVTKTA1268GRT
Q511		*HT800060R	*HT800060R	TRS.	KTC3200GR	HVTKTC3200GRT
Q512		*HT800060R	*HT800060R	TRS.	KTC3200GR	HVTKTC3200GRT
Q513		*HT800060R	*HT800060R	TRS.	KTC3200GR	HVTKTC3200GRT
Q514		*HT800060R	*HT800060R	TRS.	KTC3200GR	HVTKTC3200GRT
Q515		*HT600030R	*HT600030R	TRS.	KTA1024YT	HVTKTA1024YT
Q516		*HT600030R	*HT600030R	TRS.	KTA1024YT	HVTKTA1024YT
Q517		*HT800090R	*HT800090R	TRS.	KTC3206YA	HVTKTC3206YAT
Q518		*HT800090R	*HT800090R	TRS.	KTC3206YA	HVTKTC3206YAT
▲ Q519		HC20002080	HC20002080	IC	SAP17NLFNO.552	BVISAP17N
▲ Q520		HC20002080	HC20002080	IC	SAP17NLFNO.552	BVISAP17N
▲ Q521		HC20001080	HC20001080	IC	SAP17PLFNO.552	BVISAP17P
▲ Q522		HC20001080	HC20001080	IC	SAP17PLFNO.552	BVISAP17P
Q523		*HT800060R	*HT800060R	TRS.	KTC3200GR	HVTKTC3200GRT
Q524		*HT800060R	*HT800060R	TRS.	KTC3200GR	HVTKTC3200GRT
Q603		*HT600010R	*HT600010R	TRS.	KTA1266YT	HVTKTA1266YT
Q604		*HT600010R	*HT600010R	TRS.	KTA1266YT	HVTKTA1266YT
Q605		*HT800050R	*HT800050R	TRS.	KTC3198YT	HVTKTC3198YT
Q606		*HT800050R	*HT800050R	TRS.	KTC3198YT	HVTKTC3198YT
Q607		*HT600020R	*HT600020R	TRS.	KTA1268GR	HVTKTA1268GRT
Q608		*HT600020R	*HT600020R	TRS.	KTA1268GR	HVTKTA1268GRT
Q609		*HT600020R	*HT600020R	TRS.	KTA1268GR	HVTKTA1268GRT
Q610		*HT600020R	*HT600020R	TRS.	KTA1268GR	HVTKTA1268GRT
Q611		*HT800060R	*HT800060R	TRS.	KTC3200GR	HVTKTC3200GRT
Q612		*HT800060R	*HT800060R	TRS.	KTC3200GR	HVTKTC3200GRT
Q613		*HT800060R	*HT800060R	TRS.	KTC3200GR	HVTKTC3200GRT
Q614		*HT800060R	*HT800060R	TRS.	KTC3200GR	HVTKTC3200GRT
Q615		*HT600030R	*HT600030R	TRS.	KTA1024YT	HVTKTA1024YT
Q616		*HT600030R	*HT600030R	TRS.	KTA1024YT	HVTKTA1024YT
Q617		*HT800090R	*HT800090R	TRS.	KTC3206YA	HVTKTC3206YAT
Q618		*HT800090R	*HT800090R	TRS.	KTC3206YA	HVTKTC3206YAT
▲ Q619		HC20002080	HC20002080	IC	SAP17NLFNO.552	BVISAP17N
▲ Q620		HC20002080	HC20002080	IC	SAP17NLFNO.552	BVISAP17N
▲ Q621		HC20001080	HC20001080	IC	SAP17PLFNO.552	BVISAP17P
▲ Q622		HC20001080	HC20001080	IC	SAP17PLFNO.552	BVISAP17P
Q623		*HT800060R	*HT800060R	TRS.	KTC3200GR	HVTKTC3200GRT
Q624		*HT800060R	*HT800060R	TRS.	KTC3200GR	HVTKTC3200GRT
Q703		*HT600010R	*HT600010R	TRS.	KTA1266YT	HVTKTA1266YT
Q705		*HT800050R	*HT800050R	TRS.	KTC3198YT	HVTKTC3198YT
Q707		*HT600020R	*HT600020R	TRS.	KTA1268GR	HVTKTA1268GRT
Q709		*HT600020R	*HT600020R	TRS.	KTA1268GR	HVTKTA1268GRT
Q711		*HT800060R	*HT800060R	TRS.	KTC3200GR	HVTKTC3200GRT
Q713		*HT800060R	*HT800060R	TRS.	KTC3200GR	HVTKTC3200GRT
Q715		*HT600030R	*HT600030R	TRS.	KTA1024YT	HVTKTA1024YT
Q717		*HT800090R	*HT800090R	TRS.	KTC3206YA	HVTKTC3206YAT

NOTE : *nsp* PART IS LISTED FOR REFERENCE ONLY, MARANTZ WILL NOT SUPPLY THESE PARTS.

POS. NO	VERS. COLOR	PART NO. (FOR EUR)	PART NO. (MJ)	DESCRIPTION		
▲ Q719		HC20002080	HC20002080	IC	SAP17NLFNO.552	BVISAP17N
▲ Q721		HC20001080	HC20001080	IC	SAP17PLFNO.552	BVISAP17P
Q723		*HT800060R	*HT800060R	TRS.	KTC3200GR	HVTKTC3200GRT
Q801		*HT600020R	*HT600020R	TRS.	KTA1268GR	HVTKTA1268GRT
Q803		*HT800050R	*HT800050R	TRS.	KTC3198YT	HVTKTC3198YT
Q804		BA20001000	BA20001000	TRS.	KRC102M	HVTKRC102MT
R401		nsp	nsp	RES.	33kΩ 1/6W J	CRD20TJ333T
R402		nsp	nsp	RES.	33kΩ 1/6W J	CRD20TJ333T
R403		nsp	nsp	RES.	1kΩ 1/6W J	CRD20TJ102T
R404		nsp	nsp	RES.	1kΩ 1/6W J	CRD20TJ102T
R405		nsp	nsp	RES.	100Ω 1/6W J	CRD20TJ101T
R406		nsp	nsp	RES.	100Ω 1/6W J	CRD20TJ101T
R407		nsp	nsp	RES.	10kΩ 1/6W J	CRD20TJ103T
R408		nsp	nsp	RES.	10kΩ 1/6W J	CRD20TJ103T
R409		nsp	nsp	RES.	10kΩ 1/6W J	CRD20TJ103T
R410		nsp	nsp	RES.	10kΩ 1/6W J	CRD20TJ103T
R411		nsp	nsp	RES.	470Ω 1/6W J	CRD20TJ471T
R412		nsp	nsp	RES.	470Ω 1/6W J	CRD20TJ471T
R413		nsp	nsp	RES.	470Ω 1/6W J	CRD20TJ471T
R414		nsp	nsp	RES.	470Ω 1/6W J	CRD20TJ471T
R415		nsp	nsp	RES.	68Ω 1/6W J	CRD20TJ680T
R416		nsp	nsp	RES.	68Ω 1/6W J	CRD20TJ680T
R417		nsp	nsp	RES.	68Ω 1/6W J	CRD20TJ680T
R418		nsp	nsp	RES.	68Ω 1/6W J	CRD20TJ680T
R419		nsp	nsp	RES.	150Ω 1/6W J	CRD20TJ151T
R420		nsp	nsp	RES.	150Ω 1/6W J	CRD20TJ151T
R421		nsp	nsp	RES.	150Ω 1/6W J	CRD20TJ151T
R422		nsp	nsp	RES.	150Ω 1/6W J	CRD20TJ151T
R423		nsp	nsp	RES.	330kΩ 1/6W J	CRD20TJ334T
R424		nsp	nsp	RES.	330kΩ 1/6W J	CRD20TJ334T
R425		nsp	nsp	RES.	330kΩ 1/6W J	CRD20TJ334T
R426		nsp	nsp	RES.	330kΩ 1/6W J	CRD20TJ334T
R427		nsp	nsp	RES.	100Ω 1/6W J	CRD20TJ101T
R428		nsp	nsp	RES.	100Ω 1/6W J	CRD20TJ101T
R429		nsp	nsp	RES.	100Ω 1/6W J	CRD20TJ101T
R430		nsp	nsp	RES.	100Ω 1/6W J	CRD20TJ101T
R431		nsp	nsp	RES.	10Ω 1/4W J	CRD25TJ100T
R432		nsp	nsp	RES.	10Ω 1/4W J	CRD25TJ100T
R433		nsp	nsp	RES.	10Ω 1/4W J	CRD25TJ100T
R434		nsp	nsp	RES.	10Ω 1/4W J	CRD25TJ100T
R435		nsp	nsp	RES.	27Ω 1/6W J	CRD20TJ270T
R436		nsp	nsp	RES.	27Ω 1/6W J	CRD20TJ270T
R439		nsp	nsp	RES.	120Ω 1W J	KRG1SANJ121RT
R440		nsp	nsp	RES.	120Ω 1W J	KRG1SANJ121RT
R441		nsp	nsp	RES.	120Ω 1W J	KRG1SANJ121RT
R442		nsp	nsp	RES.	120Ω 1W J	KRG1SANJ121RT
R443		nsp	nsp	RES.	120Ω 1W J	KRG1SANJ121RT
R444		nsp	nsp	RES.	120Ω 1W J	KRG1SANJ121RT
R445		nsp	nsp	RES.	47Ω 1W J	KRG1SANJ470RT
R446		nsp	nsp	RES.	47Ω 1W J	KRG1SANJ470RT
R449		nsp	nsp	RES.	15Ω 1/6W J	CRD20TJ150T
R450		nsp	nsp	RES.	15Ω 1/6W J	CRD20TJ150T
R451		nsp	nsp	RES.	10Ω 1/6W J	CRD20TJ100T
R452		nsp	nsp	RES.	10Ω 1/6W J	CRD20TJ100T
R453		nsp	nsp	RES.	1kΩ 1/6W J	CRD20TJ102T
R454		nsp	nsp	RES.	1kΩ 1/6W J	CRD20TJ102T
R455		nsp	nsp	RES.	1kΩ 1/6W J	CRD20TJ102T

NOTE : "nsp" PART IS LISTED FOR REFERENCE ONLY, MARANTZ WILL NOT SUPPLY THESE PARTS.

POS. NO	VERS. COLOR	PART NO. (FOR EUR)	PART NO. (MJI)	DESCRIPTION		
R456		nsp	nsp	RES.	1kΩ 1/6W J	CRD20TJ102T
R457		nsp	nsp	RES.	680Ω 1/6W J	CRD20TJ681T
R458		nsp	nsp	RES.	680Ω 1/6W J	CRD20TJ681T
R459		nsp	nsp	RES.	22kΩ 1/6W J	CRD20TJ223T
R460		nsp	nsp	RES.	22kΩ 1/6W J	CRD20TJ223T
R461		nsp	nsp	RES.	22kΩ 1/6W J	CRD20TJ223T
R462		nsp	nsp	RES.	22kΩ 1/6W J	CRD20TJ223T
R463		nsp	nsp	RES.	22kΩ 1/6W J	CRD20TJ223T
R464		nsp	nsp	RES.	22kΩ 1/6W J	CRD20TJ223T
R465		nsp	nsp	RES.	680Ω 1/6W J	CRD20TJ681T
R466		nsp	nsp	RES.	680Ω 1/6W J	CRD20TJ681T
R467		nsp	nsp	RES.	33kΩ 1/6W J	CRD20TJ333T
R468		nsp	nsp	RES.	33kΩ 1/6W J	CRD20TJ333T
R469		nsp	nsp	RES.	22kΩ 1/6W J	CRD20TJ223T
R470		nsp	nsp	RES.	22kΩ 1/6W J	CRD20TJ223T
R501		nsp	nsp	RES.	33kΩ 1/6W J	CRD20TJ333T
R502		nsp	nsp	RES.	33kΩ 1/6W J	CRD20TJ333T
R503		nsp	nsp	RES.	1kΩ 1/6W J	CRD20TJ102T
R504		nsp	nsp	RES.	1kΩ 1/6W J	CRD20TJ102T
R505		nsp	nsp	RES.	100Ω 1/6W J	CRD20TJ101T
R506		nsp	nsp	RES.	100Ω 1/6W J	CRD20TJ101T
R507		nsp	nsp	RES.	10kΩ 1/6W J	CRD20TJ103T
R508		nsp	nsp	RES.	10kΩ 1/6W J	CRD20TJ103T
R509		nsp	nsp	RES.	10kΩ 1/6W J	CRD20TJ103T
R510		nsp	nsp	RES.	10kΩ 1/6W J	CRD20TJ103T
R511		nsp	nsp	RES.	470Ω 1/6W J	CRD20TJ471T
R512		nsp	nsp	RES.	470Ω 1/6W J	CRD20TJ471T
R513		nsp	nsp	RES.	470Ω 1/6W J	CRD20TJ471T
R514		nsp	nsp	RES.	470Ω 1/6W J	CRD20TJ471T
R515		nsp	nsp	RES.	68Ω 1/6W J	CRD20TJ680T
R516		nsp	nsp	RES.	68Ω 1/6W J	CRD20TJ680T
R517		nsp	nsp	RES.	68Ω 1/6W J	CRD20TJ680T
R518		nsp	nsp	RES.	68Ω 1/6W J	CRD20TJ680T
R519		nsp	nsp	RES.	150Ω 1/6W J	CRD20TJ151T
R520		nsp	nsp	RES.	150Ω 1/6W J	CRD20TJ151T
R521		nsp	nsp	RES.	150Ω 1/6W J	CRD20TJ151T
R522		nsp	nsp	RES.	150Ω 1/6W J	CRD20TJ151T
R523		nsp	nsp	RES.	330kΩ 1/6W J	CRD20TJ334T
R524		nsp	nsp	RES.	330kΩ 1/6W J	CRD20TJ334T
R525		nsp	nsp	RES.	330kΩ 1/6W J	CRD20TJ334T
R526		nsp	nsp	RES.	330kΩ 1/6W J	CRD20TJ334T
R527		nsp	nsp	RES.	100Ω 1/6W J	CRD20TJ101T
R528		nsp	nsp	RES.	100Ω 1/6W J	CRD20TJ101T
R529		nsp	nsp	RES.	100Ω 1/6W J	CRD20TJ101T
R530		nsp	nsp	RES.	100Ω 1/6W J	CRD20TJ101T
R531		nsp	nsp	RES.	10Ω 1/4W J	CRD25TJ100T
R532		nsp	nsp	RES.	10Ω 1/4W J	CRD25TJ100T
R533		nsp	nsp	RES.	10Ω 1/4W J	CRD25TJ100T
R534		nsp	nsp	RES.	10Ω 1/4W J	CRD25TJ100T
R535		nsp	nsp	RES.	27Ω 1/6W J	CRD20TJ270T
R536		nsp	nsp	RES.	27Ω 1/6W J	CRD20TJ270T
R539		nsp	nsp	RES.	120Ω 1W J	KRG1SANJ121RT
R540		nsp	nsp	RES.	120Ω 1W J	KRG1SANJ121RT
R541		nsp	nsp	RES.	120Ω 1W J	KRG1SANJ121RT
R542		nsp	nsp	RES.	120Ω 1W J	KRG1SANJ121RT
R543		nsp	nsp	RES.	120Ω 1W J	KRG1SANJ121RT
R544		nsp	nsp	RES.	120Ω 1W J	KRG1SANJ121RT

NOTE : *nsp* PART IS LISTED FOR REFERENCE ONLY, MARANTZ WILL NOT SUPPLY THESE PARTS.

POS. NO	VERS. COLOR	PART NO. (FOR EUR)	PART NO. (MJ)	DESCRIPTION		
R545		nsp	nsp	RES.	47Ω 1W J	KRG1SANJ470RT
R546		nsp	nsp	RES.	47Ω 1W J	KRG1SANJ470RT
R549		nsp	nsp	RES.	15Ω 1/6W J	CRD20TJ150T
R550		nsp	nsp	RES.	15Ω 1/6W J	CRD20TJ150T
R551		nsp	nsp	RES.	10Ω 1/6W J	CRD20TJ100T
R552		nsp	nsp	RES.	10Ω 1/6W J	CRD20TJ100T
R553		nsp	nsp	RES.	1kΩ 1/6W J	CRD20TJ102T
R554		nsp	nsp	RES.	1kΩ 1/6W J	CRD20TJ102T
R555		nsp	nsp	RES.	1kΩ 1/6W J	CRD20TJ102T
R556		nsp	nsp	RES.	1kΩ 1/6W J	CRD20TJ102T
R557		nsp	nsp	RES.	680Ω 1/6W J	CRD20TJ681T
R558		nsp	nsp	RES.	680Ω 1/6W J	CRD20TJ681T
R559		nsp	nsp	RES.	22kΩ 1/6W J	CRD20TJ223T
R560		nsp	nsp	RES.	22kΩ 1/6W J	CRD20TJ223T
R561		nsp	nsp	RES.	22kΩ 1/6W J	CRD20TJ223T
R562		nsp	nsp	RES.	22kΩ 1/6W J	CRD20TJ223T
R563		nsp	nsp	RES.	22kΩ 1/6W J	CRD20TJ223T
R564		nsp	nsp	RES.	22kΩ 1/6W J	CRD20TJ223T
R565		nsp	nsp	RES.	680Ω 1/6W J	CRD20TJ681T
R566		nsp	nsp	RES.	680Ω 1/6W J	CRD20TJ681T
R567		nsp	nsp	RES.	33kΩ 1/6W J	CRD20TJ333T
R568		nsp	nsp	RES.	33kΩ 1/6W J	CRD20TJ333T
R569		nsp	nsp	RES.	22kΩ 1/6W J	CRD20TJ223T
R570		nsp	nsp	RES.	22kΩ 1/6W J	CRD20TJ223T
R601		nsp	nsp	RES.	33kΩ 1/6W J	CRD20TJ333T
R602		nsp	nsp	RES.	33kΩ 1/6W J	CRD20TJ333T
R603		nsp	nsp	RES.	1kΩ 1/6W J	CRD20TJ102T
R604		nsp	nsp	RES.	1kΩ 1/6W J	CRD20TJ102T
R605		nsp	nsp	RES.	100Ω 1/6W J	CRD20TJ101T
R606		nsp	nsp	RES.	100Ω 1/6W J	CRD20TJ101T
R607		nsp	nsp	RES.	10kΩ 1/6W J	CRD20TJ103T
R608		nsp	nsp	RES.	10kΩ 1/6W J	CRD20TJ103T
R609		nsp	nsp	RES.	10kΩ 1/6W J	CRD20TJ103T
R610		nsp	nsp	RES.	10kΩ 1/6W J	CRD20TJ103T
R611		nsp	nsp	RES.	470Ω 1/6W J	CRD20TJ471T
R612		nsp	nsp	RES.	470Ω 1/6W J	CRD20TJ471T
R613		nsp	nsp	RES.	470Ω 1/6W J	CRD20TJ471T
R614		nsp	nsp	RES.	470Ω 1/6W J	CRD20TJ471T
R615		nsp	nsp	RES.	68Ω 1/6W J	CRD20TJ680T
R616		nsp	nsp	RES.	68Ω 1/6W J	CRD20TJ680T
R617		nsp	nsp	RES.	68Ω 1/6W J	CRD20TJ680T
R618		nsp	nsp	RES.	68Ω 1/6W J	CRD20TJ680T
R619		nsp	nsp	RES.	150Ω 1/6W J	CRD20TJ151T
R620		nsp	nsp	RES.	150Ω 1/6W J	CRD20TJ151T
R621		nsp	nsp	RES.	150Ω 1/6W J	CRD20TJ151T
R622		nsp	nsp	RES.	150Ω 1/6W J	CRD20TJ151T
R623		nsp	nsp	RES.	330kΩ 1/6W J	CRD20TJ334T
R624		nsp	nsp	RES.	330kΩ 1/6W J	CRD20TJ334T
R625		nsp	nsp	RES.	330kΩ 1/6W J	CRD20TJ334T
R626		nsp	nsp	RES.	330kΩ 1/6W J	CRD20TJ334T
R627		nsp	nsp	RES.	100Ω 1/6W J	CRD20TJ101T
R628		nsp	nsp	RES.	100Ω 1/6W J	CRD20TJ101T
R629		nsp	nsp	RES.	100Ω 1/6W J	CRD20TJ101T
R630		nsp	nsp	RES.	100Ω 1/6W J	CRD20TJ101T
R631		nsp	nsp	RES.	10Ω 1/4W J	CRD25TJ100T
R632		nsp	nsp	RES.	10Ω 1/4W J	CRD25TJ100T
R633		nsp	nsp	RES.	10Ω 1/4W J	CRD25TJ100T

NOTE : "nsp" PART IS LISTED FOR REFERENCE ONLY, MARANTZ WILL NOT SUPPLY THESE PARTS.

POS. NO	VERS. COLOR	PART NO. (FOR EUR)	PART NO. (MJI)	DESCRIPTION		
R634		nsp	nsp	RES.	10Ω 1/4W J	CRD25TJ100T
R635		nsp	nsp	RES.	27Ω 1/6W J	CRD20TJ270T
R636		nsp	nsp	RES.	27Ω 1/6W J	CRD20TJ270T
R639		nsp	nsp	RES.	120Ω 1W J	KRG1SANJ121RT
R640		nsp	nsp	RES.	120Ω 1W J	KRG1SANJ121RT
R641		nsp	nsp	RES.	120Ω 1W J	KRG1SANJ121RT
R642		nsp	nsp	RES.	120Ω 1W J	KRG1SANJ121RT
R643		nsp	nsp	RES.	120Ω 1W J	KRG1SANJ121RT
R644		nsp	nsp	RES.	120Ω 1W J	KRG1SANJ121RT
R645		nsp	nsp	RES.	47Ω 1W J	KRG1SANJ470RT
R646		nsp	nsp	RES.	47Ω 1W J	KRG1SANJ470RT
R649		nsp	nsp	RES.	15Ω 1/6W J	CRD20TJ150T
R650		nsp	nsp	RES.	15Ω 1/6W J	CRD20TJ150T
R651		nsp	nsp	RES.	10Ω 1/6W J	CRD20TJ100T
R652		nsp	nsp	RES.	10Ω 1/6W J	CRD20TJ100T
R653		nsp	nsp	RES.	1kΩ 1/6W J	CRD20TJ102T
R654		nsp	nsp	RES.	1kΩ 1/6W J	CRD20TJ102T
R655		nsp	nsp	RES.	1kΩ 1/6W J	CRD20TJ102T
R656		nsp	nsp	RES.	1kΩ 1/6W J	CRD20TJ102T
R657		nsp	nsp	RES.	680Ω 1/6W J	CRD20TJ681T
R658		nsp	nsp	RES.	680Ω 1/6W J	CRD20TJ681T
R659		nsp	nsp	RES.	22kΩ 1/6W J	CRD20TJ223T
R660		nsp	nsp	RES.	22kΩ 1/6W J	CRD20TJ223T
R661		nsp	nsp	RES.	22kΩ 1/6W J	CRD20TJ223T
R662		nsp	nsp	RES.	22kΩ 1/6W J	CRD20TJ223T
R663		nsp	nsp	RES.	22kΩ 1/6W J	CRD20TJ223T
R664		nsp	nsp	RES.	22kΩ 1/6W J	CRD20TJ223T
R665		nsp	nsp	RES.	680Ω 1/6W J	CRD20TJ681T
R666		nsp	nsp	RES.	680Ω 1/6W J	CRD20TJ681T
R667		nsp	nsp	RES.	33kΩ 1/6W J	CRD20TJ333T
R668		nsp	nsp	RES.	33kΩ 1/6W J	CRD20TJ333T
R669		nsp	nsp	RES.	22kΩ 1/6W J	CRD20TJ223T
R670		nsp	nsp	RES.	22kΩ 1/6W J	CRD20TJ223T
R701		nsp	nsp	RES.	33kΩ 1/6W J	CRD20TJ333T
R703		nsp	nsp	RES.	1kΩ 1/6W J	CRD20TJ102T
R706		nsp	nsp	RES.	100Ω 1/6W J	CRD20TJ101T
R707		nsp	nsp	RES.	10kΩ 1/6W J	CRD20TJ103T
R709		nsp	nsp	RES.	10kΩ 1/6W J	CRD20TJ103T
R711		nsp	nsp	RES.	470Ω 1/6W J	CRD20TJ471T
R713		nsp	nsp	RES.	470Ω 1/6W J	CRD20TJ471T
R715		nsp	nsp	RES.	68Ω 1/6W J	CRD20TJ680T
R717		nsp	nsp	RES.	68Ω 1/6W J	CRD20TJ680T
R719		nsp	nsp	RES.	150Ω 1/6W J	CRD20TJ151T
R721		nsp	nsp	RES.	150Ω 1/6W J	CRD20TJ151T
R723		nsp	nsp	RES.	330kΩ 1/6W J	CRD20TJ334T
R725		nsp	nsp	RES.	330kΩ 1/6W J	CRD20TJ334T
R727		nsp	nsp	RES.	100Ω 1/6W J	CRD20TJ101T
R729		nsp	nsp	RES.	100Ω 1/6W J	CRD20TJ101T
R731		nsp	nsp	RES.	10Ω 1/4W J	CRD25TJ100T
R733		nsp	nsp	RES.	10Ω 1/4W J	CRD25TJ100T
R735		nsp	nsp	RES.	27Ω 1/6W J	CRD20TJ270T
R739		nsp	nsp	RES.	120Ω 1W J	KRG1SANJ121RT
R741		nsp	nsp	RES.	120Ω 1W J	KRG1SANJ121RT
R743		nsp	nsp	RES.	120Ω 1W J	KRG1SANJ121RT
R745		nsp	nsp	RES.	47Ω 1W J	KRG1SANJ470RT
R749		nsp	nsp	RES.	15Ω 1/6W J	CRD20TJ150T
R751		nsp	nsp	RES.	10Ω 1/6W J	CRD20TJ100T

NOTE : *nsp* PART IS LISTED FOR REFERENCE ONLY, MARANTZ WILL NOT SUPPLY THESE PARTS.

POS. NO	VERS. COLOR	PART NO. (FOR EUR)	PART NO. (MJ)	DESCRIPTION		
R753		nsp	nsp	RES.	1kΩ 1/6W J	CRD20TJ102T
R755		nsp	nsp	RES.	1kΩ 1/6W J	CRD20TJ102T
R757		nsp	nsp	RES.	680Ω 1/6W J	CRD20TJ681T
R759		nsp	nsp	RES.	22kΩ 1/6W J	CRD20TJ223T
R761		nsp	nsp	RES.	22kΩ 1/6W J	CRD20TJ223T
R763		nsp	nsp	RES.	22kΩ 1/6W J	CRD20TJ223T
R767		nsp	nsp	RES.	33kΩ 1/6W J	CRD20TJ333T
R770		nsp	nsp	RES.	22kΩ 1/6W J	CRD20TJ223T
R785		nsp	nsp	RES.	680Ω 1/6W J	CRD20TJ681T
R801		nsp	nsp	RES.	68kΩ 1/6W J	CRD20TJ683T
R802		nsp	nsp	RES.	68kΩ 1/6W J	CRD20TJ683T
R803		nsp	nsp	RES.	68kΩ 1/6W J	CRD20TJ683T
R804		nsp	nsp	RES.	68kΩ 1/6W J	CRD20TJ683T
R805		nsp	nsp	RES.	68kΩ 1/6W J	CRD20TJ683T
R806		nsp	nsp	RES.	68kΩ 1/6W J	CRD20TJ683T
R807		nsp	nsp	RES.	68kΩ 1/6W J	CRD20TJ683T
R808		nsp	nsp	RES.	100kΩ 1/6W J	CRD20TJ104T
R809		nsp	nsp	RES.	22kΩ 1/6W J	CRD20TJ223T
R810		nsp	nsp	RES.	100kΩ 1/6W J	CRD20TJ104T
R811		nsp	nsp	RES.	3.3kΩ 1/6W J	CRD20TJ332T
R812		nsp	nsp	RES.	1kΩ 1/6W J	CRD20TJ102T
R813		nsp	nsp	RES.	33kΩ 1/6W J	CRD20TJ333T
R814		nsp	nsp	RES.	1kΩ 1/6W J	CRD20TJ102T
R815		nsp	nsp	RES.	3.3kΩ 1/6W J	CRD20TJ332T
R816		nsp	nsp	RES.	6.8kΩ 1/6W J	CRD20TJ682T
R817		nsp	nsp	RES.	22kΩ 1/6W J	CRD20TJ223T
R818		nsp	nsp	RES.	15kΩ 1/6W J	CRD20TJ153T
R819		nsp	nsp	RES.	33kΩ 1/6W J	CRD20TJ333T
R820		nsp	nsp	RES.	10kΩ 1/6W J	CRD20TJ103T
R821		nsp	nsp	RES.	4.7kΩ 1/6W J	CRD20TJ472T
R822		nsp	nsp	RES.	10kΩ 1/6W J	CRD20TJ103T
R823		nsp	nsp	RES.	10kΩ 1/6W J	CRD20TJ103T
TH81		HP00029230	HP00029230	VARISTOR	SR5400/SR6400	BRTPTFM04BD222Q
VR41		*RA001090R	*RA001090R	TRIM. RES.		HVN1RE221B01T
VR42		*RA001090R	*RA001090R	TRIM. RES.		HVN1RE221B01T
VR51		*RA001090R	*RA001090R	TRIM. RES.		HVN1RE221B01T
VR52		*RA001090R	*RA001090R	TRIM. RES.		HVN1RE221B01T
VR61		*RA001090R	*RA001090R	TRIM. RES.		HVN1RE221B01T
VR62		*RA001090R	*RA001090R	TRIM. RES.		HVN1RE221B01T
VR71		*RA001090R	*RA001090R	TRIM. RES.		HVN1RE221B01T
				COMPONENT PCB (CUP11660-1), 7.1CH PREOUT PCB (CUP11660-2), SBLR PCB (CUP11660-3)		
BK11		nsp	nsp	BRACKET		CMD1A387
BK12		nsp	nsp	BRACKET		CMD1A387
BN41		nsp	nsp	CONN. CORD	SR7400	CWB1B906140EN
C101		nsp	OA47601640	ELECT. CAP.	47μF 16V	HCEA1CH470T
C103		nsp	OA47601640	ELECT. CAP.	47μF 16V	HCEA1CH470T
C105		nsp	OA47601640	ELECT. CAP.	47μF 16V	HCEA1CH470T
C107		nsp	OA47601640	ELECT. CAP.	47μF 16V	HCEA1CH470T
C109		nsp	OA47601640	ELECT. CAP.	47μF 16V	HCEA1CH470T
C111		nsp	OA47601640	ELECT. CAP.	47μF 16V	HCEA1CH470T
C113		nsp	OA47701020	ELECT. CAP.	470μF 10V	HCEA1AH471T
C115		nsp	nsp	CER. CAP.	0.01μF 50V Z	HCBS1H103ZFT
C117		nsp	OA47701020	ELECT. CAP.	470μF 10V	HCEA1AH471T
C119		nsp	nsp	CER. CAP.	0.01μF 50V Z	HCBS1H103ZFT

NOTE : "nsp" PART IS LISTED FOR REFERENCE ONLY, MARANTZ WILL NOT SUPPLY THESE PARTS.

POS. NO	VERS. COLOR	PART NO. (FOR EUR)	PART NO. (MJI)	DESCRIPTION		
C120		nsp	OA47701020	ELECT. CAP.	470µF 10V	HCEA1AH471T
C121		nsp	nsp	CER. CAP.	0.01µF 50V Z	HCBS1H103ZFT
C122		nsp	nsp	CER. CAP.	0.01µF 50V Z	HCBS1H103ZFT
C123		nsp	OA47601640	ELECT. CAP.	47µF 16V	HCEA1CH470T
C124		nsp	nsp	CER. CAP.	0.01µF 50V Z	HCBS1H103ZFT
C125		nsp	OA47601640	ELECT. CAP.	47µF 16V	HCEA1CH470T
C126		nsp	nsp	CER. CAP.	0.01µF 50V Z	HCBS1H103ZFT
C127		nsp	OA47601640	ELECT. CAP.	47µF 16V	HCEA1CH470T
C128		nsp	nsp	CER. CAP.	0.01µF 50V Z	HCBS1H103ZFT
C129		nsp	OA47601640	ELECT. CAP.	47µF 16V	HCEA1CH470T
C130		nsp	nsp	CER. CAP.	0.01µF 50V Z	HCBS1H103ZFT
C131		nsp	nsp	CER. CAP.	0.01µF 50V Z	HCBS1H103ZFT
C132		nsp	nsp	CER. CAP.	0.01µF 50V Z	HCBS1H103ZFT
C133		nsp	OA10701620	ELECT. CAP.	100µF 16V	HCEA1CH101T
C134		nsp	OA10701620	ELECT. CAP.	100µF 16V	HCEA1CH101T
C135		nsp	nsp	CER. CAP.	0.01µF 50V Z	HCBS1H103ZFT
C136		nsp	nsp	CER. CAP.	0.01µF 50V Z	HCBS1H103ZFT
C137		nsp	nsp	CER. CAP.	0.01µF 50V Z	HCBS1H103ZFT
C138		nsp	nsp	CER. CAP.	0.01µF 50V Z	HCBS1H103ZFT
C139		nsp	OA10605020	ELECT. CAP.	10µF 50V	HCEA1HH100T
C140		nsp	nsp	CER. CAP.	0.01µF 50V Z	HCBS1H103ZFT
C141		nsp	OA10605020	ELECT. CAP.	10µF 50V	HCEA1HH100T
C142		nsp	nsp	CER. CAP.	0.01µF 50V Z	HCBS1H103ZFT
C143		nsp	OA47601640	ELECT. CAP.	47µF 16V	HCEA1CH470T
C144		nsp	OA47601640	ELECT. CAP.	47µF 16V	HCEA1CH470T
C145		nsp	nsp	CER. CAP.	0.01µF 50V Z	HCBS1H103ZFT
C146		nsp	OA47601640	ELECT. CAP.	47µF 16V	HCEA1CH470T
C147		nsp	nsp	CER. CAP.	0.01µF 50V Z	HCBS1H103ZFT
C148		nsp	OA47601640	ELECT. CAP.	47µF 16V	HCEA1CH470T
C149		nsp	nsp	CER. CAP.	0.01µF 50V Z	HCBS1H103ZFT
C150		nsp	OA47601640	ELECT. CAP.	47µF 16V	HCEA1CH470T
C151		nsp	OA47601640	ELECT. CAP.	47µF 16V	HCEA1CH470T
C152		nsp	OA47601640	ELECT. CAP.	47µF 16V	HCEA1CH470T
C153		nsp	OA10605020	ELECT. CAP.	10µF 50V	HCEA1HH100T
C154		nsp	OA10605020	ELECT. CAP.	10µF 50V	HCEA1HH100T
C155		nsp	nsp	CER. CAP.	0.01µF 50V Z	HCBS1H103ZFT
C156		nsp	OA10605020	ELECT. CAP.	10µF 50V	HCEA1HH100T
C160		*OF100370R	*OF100370R	FILM CAP	0.022µF 50V J	HCQI1H223JZT
C161		*OF100370R	*OF100370R	FILM CAP	0.022µF 50V J	HCQI1H223JZT
C162		*OF100370R	*OF100370R	FILM CAP	0.022µF 50V J	HCQI1H223JZT
C163		*OF100370R	*OF100370R	FILM CAP	0.022µF 50V J	HCQI1H223JZT
C164		nsp	nsp	CER. CAP.	1000pF 50V KB	CCKT1H102KB
C165		nsp	nsp	CER. CAP.	50V 0.1µF	CCKT1H104ZF
C166		nsp	nsp	CER. CAP.	50V 0.1µF	CCKT1H104ZF
C170		nsp	nsp	CER. CAP.	470pF 50V KB	CCKT1H471KB
C171		nsp	nsp	CER. CAP.	470pF 50V KB	CCKT1H471KB
C172		nsp	nsp	CER. CAP.	470pF 50V KB	CCKT1H471KB
C173		nsp	nsp	CER. CAP.	470pF 50V KB	CCKT1H471KB
C174		nsp	nsp	CER. CAP.	470pF 50V KB	CCKT1H471KB
C175		nsp	nsp	CER. CAP.	470pF 50V KB	CCKT1H471KB
C176		nsp	nsp	CER. CAP.	470pF 50V KB	CCKT1H471KB
C177		nsp	nsp	CER. CAP.	470pF 50V KB	CCKT1H471KB
C180		nsp	nsp	CER. CAP.	2.2pF 50V K	HCBS1H2R2KCT
C181		nsp	nsp	CER. CAP.	2.2pF 50V K	HCBS1H2R2KCT
C182		nsp	nsp	CER. CAP.	2.2pF 50V K	HCBS1H2R2KCT
CN22		nsp	nsp	JACK		KJP15GA19ZM
CN42		nsp	nsp	JACK	GF102-07S-TS	KJP07GA117ZG

NOTE : *nsp* PART IS LISTED FOR REFERENCE ONLY, MARANTZ WILL NOT SUPPLY THESE PARTS.

POS. NO	VERS. COLOR	PART NO. (FOR EUR)	PART NO. (MJI)	DESCRIPTION		
CN81		nsp	nsp	JACK	MOLEX53014-0610	KJP06GA19ZM
CN82		YP04000760	YP04000760	JACK	MOLEX35328-02	KJP02GA89ZM
CN83		YP04000760	YP04000760	JACK	MOLEX35328-02	KJP02GA89ZM
D101		nsp	*HD201750R	DIODE	TW 1N4003	KVD1N4003SRT
IC11		HC10230090	HC10230090	IC	NJM2584D	HVINJM2584D
IC12		HC10230090	HC10230090	IC	NJM2581D	HVINJM2581D
IC13		HC10230090	HC10230090	IC	NJM2584D	HVINJM2584D
J101						
J120		nsp	nsp	JUMPER	SN95/PB5 , 0.6	C3A206
JK11		*YT003210R	*YT003210R	TERMINAL	3P,G/B/R,SILVER	CJJ4S030Z
JK12		*YT003210R	*YT003210R	TERMINAL	3P,G/B/R,SILVER	CJJ4S030Z
JK13		*YT003210R	*YT003210R	TERMINAL	3P,G/B/R,SILVER	CJJ4S030Z
JK14		*YT003670R	*YT003670R	TERMINAL		CJJ5P012Z
JK15		*YT003660R	*YT003660R	TERMINAL	SILVER PLATE	CJJ4P045Z
JK16		*YT003660R	*YT003660R	TERMINAL	SILVER PLATE	CJJ4P045Z
Q101		HT30001000	HT30001000	TRS.	KTC3199YT	HVTKTC3199YT
Q102		*HT600040R	*HT600040R	TRS.	KTA1267YT	HVTKTA1267YT
Q103		*HT600040R	*HT600040R	TRS.	KTA1267YT	HVTKTA1267YT
R101		nsp	nsp	RES.	75Ω 1/6W J	CRD20TJ750T
R102		nsp	nsp	RES.	75Ω 1/6W J	CRD20TJ750T
R103		nsp	nsp	RES.	75Ω 1/6W J	CRD20TJ750T
R104		nsp	nsp	RES.	75Ω 1/6W J	CRD20TJ750T
R105		nsp	nsp	RES.	75Ω 1/6W J	CRD20TJ750T
R106		nsp	nsp	RES.	75Ω 1/6W J	CRD20TJ750T
R107		nsp	nsp	RES.	75Ω 1/6W J	CRD20TJ750T
R108		nsp	nsp	RES.	75Ω 1/6W J	CRD20TJ750T
R109		nsp	nsp	RES.	75Ω 1/6W J	CRD20TJ750T
R110		nsp	nsp	RES.	1MΩ 1/6W J	CRD20TJ105T
R111		nsp	nsp	RES.	1MΩ 1/6W J	CRD20TJ105T
R116		nsp	nsp	RES.	1MΩ 1/6W J	CRD20TJ105T
R118		nsp	nsp	RES.	1MΩ 1/6W J	CRD20TJ105T
R121		nsp	nsp	RES.	12kΩ 1/6W J	CRD20TJ123T
R122		nsp	nsp	RES.	10kΩ 1/6W J	CRD20TJ103T
R123		nsp	nsp	RES.	470Ω 1/6W J	CRD20TJ471T
R124		nsp	nsp	RES.	470Ω 1/6W J	CRD20TJ471T
R125		nsp	nsp	RES.	470Ω 1/6W J	CRD20TJ471T
R126		nsp	nsp	RES.	10kΩ 1/6W J	CRD20TJ103T
R130		nsp	nsp	RES.	10Ω 1W J	KRG1SANJ100RT
R131		nsp	nsp	RES.	10Ω 1W J	KRG1SANJ100RT
R132		nsp	nsp	RES.	10kΩ 1/6W J	CRD20TJ103T
R133		nsp	nsp	RES.	10kΩ 1/6W J	CRD20TJ103T
R134		nsp	nsp	RES.	220Ω 1/4W J	CRD25TJ221T
R135		nsp	nsp	RES.	330Ω 1/4W J	CRD25TJ331T
RY11		LY20240490	LY20240490	RELAY	5GPA-28 DC24	HSL3B013ZE
					DSP PCB (CUP11658Z)	
BC11		nsp	nsp	JUMPER	SN95/PB5 , 0.6	C3A206
BC12		nsp	nsp	JUMPER	SN95/PB5 , 0.6	C3A206
BC13		nsp	nsp	JUMPER	SN95/PB5 , 0.6	C3A206
BN33		nsp	nsp	JACK	MOLEX53014-0710	KJP07GA19ZM
C101		nsp	OA47601640	ELECT. CAP.	47μF 16V	HCEA1CH470T
C102		nsp	DK96103300	CER. CAP.	0.01μF	HCUS1H103KC
C103		nsp	OA47601640	ELECT. CAP.	47μF 16V	HCEA1CH470T
C104		nsp	DK96103300	CER. CAP.	0.01μF	HCUS1H103KC
C105		nsp	OA47601640	ELECT. CAP.	47μF 16V	HCEA1CH470T
C106		nsp	DK96103300	CER. CAP.	0.01μF	HCUS1H103KC

NOTE : "nsp" PART IS LISTED FOR REFERENCE ONLY, MARANTZ WILL NOT SUPPLY THESE PARTS.

POS. NO	VERS. COLOR	PART NO. (FOR EUR)	PART NO. (MJI)	DESCRIPTION		
C107		nsp	DD95101300	CER. CAP.	100pF	HCUS1H101JA
C108		nsp	DK96104300	CER. CAP.	0.1µF 1608 SIZE	HCUS1E104ZF
C109		nsp	DD95101300	CER. CAP.	100pF	HCUS1H101JA
C110		nsp	DK96104300	CER. CAP.	0.1µF 1608 SIZE	HCUS1E104ZF
C111		nsp	DD95101300	CER. CAP.	100pF	HCUS1H101JA
C112		nsp	DK96104300	CER. CAP.	0.1µF 1608 SIZE	HCUS1E104ZF
C113		nsp	DD95330300	CER. CAP.	33pF	HCUS1H330JA
C114		nsp	DK96104300	CER. CAP.	0.1µF 1608 SIZE	HCUS1E104ZF
C115		nsp	DK96104300	CER. CAP.	0.1µF 1608 SIZE	HCUS1E104ZF
C116		nsp	DD95330300	CER. CAP.	33pF	HCUS1H330JA
C117		nsp	DK96103300	CER. CAP.	0.01µF	HCUS1H103KC
C118		nsp	OA47601640	ELECT. CAP.	47µF 16V	HCEA1CH470T
C119		nsp	DK96104300	CER. CAP.	0.1µF 1608 SIZE	HCUS1E104ZF
C120		nsp	DK96104300	CER. CAP.	0.1µF 1608 SIZE	HCUS1E104ZF
C121		nsp	DK96104300	CER. CAP.	0.1µF 1608 SIZE	HCUS1E104ZF
C122		nsp	OA22605020	ELECT. CAP.	22µF 50V	HCEA1EH220T
C123		nsp	DK96104300	CER. CAP.	0.1µF 1608 SIZE	HCUS1E104ZF
C124		nsp	DK96104300	CER. CAP.	0.1µF 1608 SIZE	HCUS1E104ZF
C125		nsp	DK98223300	CER. CAP.	0.022µF	HCUS1H223KC
C126		nsp	DK96104300	CER. CAP.	0.1µF 1608 SIZE	HCUS1E104ZF
C127		nsp	OA22605020	ELECT. CAP.	22µF 50V	HCEA1EH220T
C128		nsp	DK96104300	CER. CAP.	0.1µF 1608 SIZE	HCUS1E104ZF
C129		nsp	OA22605020	ELECT. CAP.	22µF 50V	HCEA1EH220T
C130		nsp	DK96104300	CER. CAP.	0.1µF 1608 SIZE	HCUS1E104ZF
C131		nsp	OA22605020	ELECT. CAP.	22µF 50V	HCEA1EH220T
C132		nsp	DD95330300	CER. CAP.	33pF	HCUS1H330JA
C133		nsp	DD95330300	CER. CAP.	33pF	HCUS1H330JA
C134		nsp	DK96104300	CER. CAP.	0.1µF 1608 SIZE	HCUS1E104ZF
C135		nsp	DD95101300	CER. CAP.	100pF	HCUS1H101JA
C136		nsp	DK96104300	CER. CAP.	0.1µF 1608 SIZE	HCUS1E104ZF
C137		nsp	OA22605020	ELECT. CAP.	22µF 50V	HCEA1EH220T
C138		nsp	OA22605020	ELECT. CAP.	22µF 50V	HCEA1EH220T
C139		nsp	OA22605020	ELECT. CAP.	22µF 50V	HCEA1EH220T
C141		nsp	DD95101300	CER. CAP.	100pF	HCUS1H101JA
C142		nsp	DD95151300	CER. CAP.	150pF	HCUS1H151JA
C143		nsp	DK96104300	CER. CAP.	0.1µF 1608 SIZE	HCUS1E104ZF
C144		nsp	DK96272300	CER. CAP.	2700pF	HCUS1H272KC
C145		nsp	OA22605020	ELECT. CAP.	22µF 50V	HCEA1EH220T
C146		nsp	OA22605020	ELECT. CAP.	22µF 50V	HCEA1EH220T
C148		nsp	DD95101300	CER. CAP.	100pF	HCUS1H101JA
C149		nsp	DD95151300	CER. CAP.	150pF	HCUS1H151JA
C150		nsp	DK96104300	CER. CAP.	0.1µF 1608 SIZE	HCUS1E104ZF
C151		nsp	DK96272300	CER. CAP.	2700pF	HCUS1H272KC
C152		nsp	OA10701620	ELECT. CAP.	100µF 16V	HCEA1CH101T
C153		nsp	DK96104300	CER. CAP.	0.1µF 1608 SIZE	HCUS1E104ZF
C154		nsp	DD95471300	CER. CAP.	470pF	HCUS1H471JA
C155		nsp	DK96104300	CER. CAP.	0.1µF 1608 SIZE	HCUS1E104ZF
C156		nsp	OA22605020	ELECT. CAP.	22µF 50V	HCEA1EH220T
C157		nsp	DK96104300	CER. CAP.	0.1µF 1608 SIZE	HCUS1E104ZF
C158		nsp	OA22605020	ELECT. CAP.	22µF 50V	HCEA1EH220T
C159		nsp	DK96104300	CER. CAP.	0.1µF 1608 SIZE	HCUS1E104ZF
C160		nsp	OA22605020	ELECT. CAP.	22µF 50V	HCEA1EH220T
C161		nsp	DK96104300	CER. CAP.	0.1µF 1608 SIZE	HCUS1E104ZF
C162		nsp	OA22605020	ELECT. CAP.	22µF 50V	HCEA1EH220T
C163		nsp	DK96104300	CER. CAP.	0.1µF 1608 SIZE	HCUS1E104ZF
C164		nsp	DK96104300	CER. CAP.	0.1µF 1608 SIZE	HCUS1E104ZF
C165		nsp	OA22605020	ELECT. CAP.	22µF 50V	HCEA1EH220T

NOTE : *nsp* PART IS LISTED FOR REFERENCE ONLY, MARANTZ WILL NOT SUPPLY THESE PARTS.

POS. NO	VERS. COLOR	PART NO. (FOR EUR)	PART NO. (MJI)	DESCRIPTION		
C166		nsp	DK96104300	CER. CAP.	0.1µF 1608 SIZE	HCUS1E104ZF
C167		nsp	OA22505020	ELECT. CAP.	2.2µF 50V	HCEA1HH2R2T
C168		nsp	DD95680300	CER. CAP.	68pF	HCUS1H680JA
C169		nsp	DK96122300	CER. CAP.	1200pF	HCUS1H122KC
C170		nsp	DK96103300	CER. CAP.	0.01µF	HCUS1H103KC
C171		nsp	DK96105200	CER. CAP.	1µF	HCUS1C105ZF
C172		nsp	OA47601640	ELECT. CAP.	47µF 16V	HCEA1CH470T
C173		nsp	DK96104300	CER. CAP.	0.1µF 1608 SIZE	HCUS1E104ZF
C174		nsp	DK96104300	CER. CAP.	0.1µF 1608 SIZE	HCUS1E104ZF
C175		nsp	OA22605020	ELECT. CAP.	22µF 50V	HCEA1EH220T
C176		nsp	DK96104300	CER. CAP.	0.1µF 1608 SIZE	HCUS1E104ZF
C177		nsp	DK96104300	CER. CAP.	0.1µF 1608 SIZE	HCUS1E104ZF
C178		nsp	DK96104300	CER. CAP.	0.1µF 1608 SIZE	HCUS1E104ZF
C179		nsp	OA22605020	ELECT. CAP.	22µF 50V	HCEA1EH220T
C180		nsp	DK96104300	CER. CAP.	0.1µF 1608 SIZE	HCUS1E104ZF
C181		nsp	OA22605020	ELECT. CAP.	22µF 50V	HCEA1EH220T
C182		nsp	DK96104300	CER. CAP.	0.1µF 1608 SIZE	HCUS1E104ZF
C183		nsp	DK96104300	CER. CAP.	0.1µF 1608 SIZE	HCUS1E104ZF
C184		nsp	DK96104300	CER. CAP.	0.1µF 1608 SIZE	HCUS1E104ZF
C185		nsp	OA22605020	ELECT. CAP.	22µF 50V	HCEA1EH220T
C186		nsp	DK96104300	CER. CAP.	0.1µF 1608 SIZE	HCUS1E104ZF
C187		nsp	OA22605020	ELECT. CAP.	22µF 50V	HCEA1EH220T
C188		nsp	DK96104300	CER. CAP.	0.1µF 1608 SIZE	HCUS1E104ZF
C189		nsp	DK96104300	CER. CAP.	0.1µF 1608 SIZE	HCUS1E104ZF
C190		nsp	DK96104300	CER. CAP.	0.1µF 1608 SIZE	HCUS1E104ZF
C191		nsp	DK96104300	CER. CAP.	0.1µF 1608 SIZE	HCUS1E104ZF
C192		nsp	DK96104300	CER. CAP.	0.1µF 1608 SIZE	HCUS1E104ZF
C193		nsp	OA22605020	ELECT. CAP.	22µF 50V	HCEA1EH220T
C194		nsp	DK96104300	CER. CAP.	0.1µF 1608 SIZE	HCUS1E104ZF
C195		nsp	OA22605020	ELECT. CAP.	22µF 50V	HCEA1EH220T
C196		nsp	DD95101300	CER. CAP.	100pF	HCUS1H101JA
C197		nsp	DK96104300	CER. CAP.	0.1µF 1608 SIZE	HCUS1E104ZF
C198		nsp	OA10505020	ELECT. CAP.	1µF 50V	HCEA1HH1R0T
C199		nsp	DK96104300	CER. CAP.	0.1µF 1608 SIZE	HCUS1E104ZF
C200		nsp	OA47601640	ELECT. CAP.	47µF 16V	HCEA1CH470T
C201		nsp	DK96104300	CER. CAP.	0.1µF 1608 SIZE	HCUS1E104ZF
C202		nsp	OA10701620	ELECT. CAP.	100µF 16V	HCEA1CH101T
C203		nsp	DK96104300	CER. CAP.	0.1µF 1608 SIZE	HCUS1E104ZF
C204		nsp	OA22605020	ELECT. CAP.	22µF 50V	HCEA1EH220T
C205		nsp	DK96332300	CER. CAP.	3300pF	HCUS1H332KC
C206		nsp	DD95471300	CER. CAP.	470pF	HCUS1H471JA
C207		nsp	DK96332300	CER. CAP.	3300pF	HCUS1H332KC
C208		nsp	DD95471300	CER. CAP.	470pF	HCUS1H471JA
C209		nsp	DK96104300	CER. CAP.	0.1µF 1608 SIZE	HCUS1E104ZF
C210		nsp	OA22605020	ELECT. CAP.	22µF 50V	HCEA1EH220T
C211		nsp	DK96102300	CER. CAP.	1000pF	HCUS1H102KC
C212		nsp	DK96332300	CER. CAP.	3300pF	HCUS1H332KC
C213		nsp	DD95471300	CER. CAP.	470pF	HCUS1H471JA
C214		nsp	DK96332300	CER. CAP.	3300pF	HCUS1H332KC
C215		nsp	DD95471300	CER. CAP.	470pF	HCUS1H471JA
C216		nsp	DK96104300	CER. CAP.	0.1µF 1608 SIZE	HCUS1E104ZF
C217		nsp	OA22605020	ELECT. CAP.	22µF 50V	HCEA1EH220T
C218		nsp	DK96102300	CER. CAP.	1000pF	HCUS1H102KC
C219		nsp	DK96332300	CER. CAP.	3300pF	HCUS1H332KC
C220		nsp	DD95471300	CER. CAP.	470pF	HCUS1H471JA
C221		nsp	DK96332300	CER. CAP.	3300pF	HCUS1H332KC
C222		nsp	DD95471300	CER. CAP.	470pF	HCUS1H471JA

NOTE : "nsp" PART IS LISTED FOR REFERENCE ONLY, MARANTZ WILL NOT SUPPLY THESE PARTS.

POS. NO	VERS. COLOR	PART NO. (FOR EUR)	PART NO. (MJI)	DESCRIPTION		
C223		nsp	DK96104300	CER. CAP.	0.1µF 1608 SIZE	HCUS1E104ZF
C224		nsp	OA22605020	ELECT. CAP.	22µF 50V	HCEA1EH220T
C225		nsp	DK96102300	CER. CAP.	1000pF	HCUS1H102KC
C226		nsp	DK96332300	CER. CAP.	3300pF	HCUS1H332KC
C227		nsp	DD95471300	CER. CAP.	470pF	HCUS1H471JA
C228		nsp	DK96332300	CER. CAP.	3300pF	HCUS1H332KC
C229		nsp	DD95471300	CER. CAP.	470pF	HCUS1H471JA
C230		nsp	DK96104300	CER. CAP.	0.1µF 1608 SIZE	HCUS1E104ZF
C231		nsp	OA22605020	ELECT. CAP.	22µF 50V	HCEA1EH220T
C232		nsp	DK96102300	CER. CAP.	1000pF	HCUS1H102KC
C233		nsp	DK96332300	CER. CAP.	3300pF	HCUS1H332KC
C234		nsp	DD95471300	CER. CAP.	470pF	HCUS1H471JA
C235		nsp	DK96332300	CER. CAP.	3300pF	HCUS1H332KC
C236		nsp	DD95471300	CER. CAP.	470pF	HCUS1H471JA
C237		nsp	DK96104300	CER. CAP.	0.1µF 1608 SIZE	HCUS1E104ZF
C238		nsp	OA22605020	ELECT. CAP.	22µF 50V	HCEA1EH220T
C239		nsp	DK96102300	CER. CAP.	1000pF	HCUS1H102KC
C241		nsp	DK96332300	CER. CAP.	3300pF	HCUS1H332KC
C242		nsp	DD95471300	CER. CAP.	470pF	HCUS1H471JA
C243		nsp	DK96332300	CER. CAP.	3300pF	HCUS1H332KC
C244		nsp	DD95471300	CER. CAP.	470pF	HCUS1H471JA
C245		nsp	DK96104300	CER. CAP.	0.1µF 1608 SIZE	HCUS1E104ZF
C246		nsp	OA22605020	ELECT. CAP.	22µF 50V	HCEA1EH220T
C247		nsp	DK96102300	CER. CAP.	1000pF	HCUS1H102KC
C248		nsp	DK96332300	CER. CAP.	3300pF	HCUS1H332KC
C249		nsp	DD95471300	CER. CAP.	470pF	HCUS1H471JA
C250		nsp	DK96332300	CER. CAP.	3300pF	HCUS1H332KC
C251		nsp	DD95471300	CER. CAP.	470pF	HCUS1H471JA
C252		nsp	DK96104300	CER. CAP.	0.1µF 1608 SIZE	HCUS1E104ZF
C253		nsp	OA22605020	ELECT. CAP.	22µF 50V	HCEA1EH220T
C254		nsp	DK96102300	CER. CAP.	1000pF	HCUS1H102KC
C255		nsp	DK96103300	CER. CAP.	0.01µF	HCUS1H103KC
C256		nsp	DK96103300	CER. CAP.	0.01µF	HCUS1H103KC
C257		nsp	DD95330300	CER. CAP.	33pF	HCUS1H330JA
C258		nsp	DK96103300	CER. CAP.	0.01µF	HCUS1H103KC
C259		nsp	DK96103300	CER. CAP.	0.01µF	HCUS1H103KC
C260		nsp	DK96103300	CER. CAP.	0.01µF	HCUS1H103KC
C261		nsp	DK96103300	CER. CAP.	0.01µF	HCUS1H103KC
C262		nsp	DK96103300	CER. CAP.	0.01µF	HCUS1H103KC
C264		nsp	DK96104300	CER. CAP.	0.1µF 1608 SIZE	HCUS1E104ZF
C265		nsp	OA47601640	ELECT. CAP.	47µF 16V	HCEA1CH470T
C266		nsp	DK96104300	CER. CAP.	0.1µF 1608 SIZE	HCUS1E104ZF
C267		nsp	OA47601640	ELECT. CAP.	47µF 16V	HCEA1CH470T
C268		nsp	DK96332300	CER. CAP.	3300pF	HCUS1H332KC
C269		nsp	DD95471300	CER. CAP.	470pF	HCUS1H471JA
C270		nsp	DK96332300	CER. CAP.	3300pF	HCUS1H332KC
C271		nsp	DD95471300	CER. CAP.	470pF	HCUS1H471JA
C272		nsp	DK96104300	CER. CAP.	0.1µF 1608 SIZE	HCUS1E104ZF
C273		nsp	OA22605020	ELECT. CAP.	22µF 50V	HCEA1EH220T
C274		nsp	DK96102300	CER. CAP.	1000pF	HCUS1H102KC
C280		nsp	DD95330300	CER. CAP.	33pF	HCUS1H330JA
C281		nsp	DD95330300	CER. CAP.	33pF	HCUS1H330JA
C282		nsp	DK96104300	CER. CAP.	0.1µF 1608 SIZE	HCUS1E104ZF
CC11		nsp	DK96104300	CER. CAP.	0.1µF 1608 SIZE	HCUS1E104ZF
CC12		nsp	OA22605020	ELECT. CAP.	22µF 50V	HCEA1EH220T
CC13		nsp	DK96104300	CER. CAP.	0.1µF 1608 SIZE	HCUS1E104ZF
CC14		nsp	DD91100300	CER. CAP.	10pF	HCUS1H100JA

NOTE : *nsp* PART IS LISTED FOR REFERENCE ONLY, MARANTZ WILL NOT SUPPLY THESE PARTS.

POS. NO	VERS. COLOR	PART NO. (FOR EUR)	PART NO. (MJI)	DESCRIPTION		
CC15		nsp	DK96104300	CER. CAP.	0.1µF 1608 SIZE	HCUS1E104ZF
CC16		nsp	DK96104300	CER. CAP.	0.1µF 1608 SIZE	HCUS1E104ZF
CC17		nsp	OA22605020	ELECT. CAP.	22µF 50V	HCEA1EH220T
CC18		nsp	DK96104300	CER. CAP.	0.1µF 1608 SIZE	HCUS1E104ZF
CC19		nsp	DK98474200	CER. CAP.	0.47µF	HCUS1C474ZF
CC20		nsp	OA22605020	ELECT. CAP.	22µF 50V	HCEA1EH220T
CC21		nsp	DK96104300	CER. CAP.	0.1µF 1608 SIZE	HCUS1E104ZF
CC22		nsp	DK96104300	CER. CAP.	0.1µF 1608 SIZE	HCUS1E104ZF
CC23		nsp	DD95220300	CER. CAP.	22pF	HCUS1H220JA
CC24		nsp	DD95220300	CER. CAP.	22pF	HCUS1H220JA
CC25		nsp	DK96104300	CER. CAP.	0.1µF 1608 SIZE	HCUS1E104ZF
CC26		nsp	OA22605020	ELECT. CAP.	22µF 50V	HCEA1EH220T
CC27		nsp	DK96104300	CER. CAP.	0.1µF 1608 SIZE	HCUS1E104ZF
CC28		nsp	DK96104300	CER. CAP.	0.1µF 1608 SIZE	HCUS1E104ZF
CC29		nsp	DK96104300	CER. CAP.	0.1µF 1608 SIZE	HCUS1E104ZF
CC30		nsp	OA10701620	ELECT. CAP.	100µF 16V	HCEA1CH101T
CC31		nsp	DK96104300	CER. CAP.	0.1µF 1608 SIZE	HCUS1E104ZF
CC32		nsp	DK96104300	CER. CAP.	0.1µF 1608 SIZE	HCUS1E104ZF
CC33		nsp	OA10701620	ELECT. CAP.	100µF 16V	HCEA1CH101T
CC34		nsp	OA22801620	ELECT. CAP.	2200µF 16V	HCEA1CH222E
CC35		nsp	OA22801620	ELECT. CAP.	2200µF 16V	HCEA1CH222E
CC36		nsp	OA22701620	ELECT. CAP.	220µF 16V	HCEA1CH221T
CC37		nsp	DK96104300	CER. CAP.	0.1µF 1608 SIZE	HCUS1E104ZF
CC38		nsp	OA10701620	ELECT. CAP.	100µF 16V	HCEA1CH101T
CC39		nsp	DK96104300	CER. CAP.	0.1µF 1608 SIZE	HCUS1E104ZF
CC40		nsp	OA10701620	ELECT. CAP.	100µF 16V	HCEA1CH101T
CC41		nsp	DK96104300	CER. CAP.	0.1µF 1608 SIZE	HCUS1E104ZF
CC42		nsp	OA10701620	ELECT. CAP.	100µF 16V	HCEA1CH101T
CC43		nsp	DK96104300	CER. CAP.	0.1µF 1608 SIZE	HCUS1E104ZF
CC44		nsp	DK96104300	CER. CAP.	0.1µF 1608 SIZE	HCUS1E104ZF
CN16		nsp	nsp	JACK	GF102-16S-TS	KJP16GA117ZG
CN26		nsp	nsp	JACK		KJP19GA117ZG
CN28		nsp	nsp	JACK	GF120-17S-TS	KJP17GA115ZG
CN30		nsp	nsp	JACK	MOLEX53014-0910	KJP09GA19ZM
CN34	F/K/N/S	nsp	nsp	JACK	GF120-17S-TS	KJP17GA115ZG
CN34	L/U	nsp	nsp	JACK	GF120-15S-TS	KJP15GA115ZG
CN36		nsp	nsp	JACK	GF102-11S-TS	KJP11GA117ZG
CN38		nsp	nsp	JACK	GF102-13S-TS	KJP13GA117ZG
CN40		nsp	nsp	JACK	MOLEX53014-0610	KJP06GA19ZM
CN85		nsp	nsp	JACK		KJP02GA19ZM
DC11		nsp	HD20015210	DIODE	1SS133T-77	HVD1SS133MT
DC12		nsp	HD20015210	DIODE	1SS133T-77	HVD1SS133MT
DC13		nsp	HD20015210	DIODE	1SS133T-77	HVD1SS133MT
DC14		nsp	HD20015210	DIODE	1SS133T-77	HVD1SS133MT
DC15		*HI200020R	*HI200020R	L.E.D.	SIR-34ST3F	BVDSIR34ST3F
ET01		nsp	nsp	TERMINAL		CNE75
ET02		nsp	nsp	TERMINAL		CNE75
IC11		HC700400Z0	HC700400Z0	IC	TC74HCU04AFN	HVITC74HCU04AFN
IC12		HC700400Z0	HC700400Z0	IC	TC74HCU04AFN	HVITC74HCU04AFN
IC13		HC10418030	HC10418030	IC	LC89057W-VF4-E	HVILC89057WVF4E
IC14		HC10102090	HC10102090	IC	NJM2115M	HVINJM2115MDTE1
IC15		HC10102090	HC10102090	IC	NJM2115M	HVINJM2115MDTE1
IC16		HC10015880	HC10015880	IC	CS5361-KS	HVICS5361-KS
IC17		HC007505K0	HC007505K0	IC	TC74VHCT08FT	HVITC74VHCT08FT
IC18		*HC108430R	*HC108430R	IC	TC74HC7007AFEL	HVITC74HCT7007F
IC19		HC10014880	HC10014880	IC	CS49400-CQ	HVICS49400-CQ
IC20		*HS27AWX0R	*HS27AWX0R	ONE TIME PROM	MX29LV400TTC-70	HVIMX29LV400TTC

NOTE : "nsp" PART IS LISTED FOR REFERENCE ONLY, MARANTZ WILL NOT SUPPLY THESE PARTS.

POS. NO	VERS. COLOR	PART NO. (FOR EUR)	PART NO. (MJI)	DESCRIPTION		
IC21		HC007505K0	HC007505K0	IC	TC74VHCT08FT	HVITC74VHCT08FT
IC22		HC010505K0	HC010505K0	IC	TC74VHCT32AFT	HVITC74VHCT32FT
IC23		HC10012880	HC10012880	IC	CS4382-KQ	HVICS4382-KQ
IC24		HC10102090	HC10102090	IC	NJM2068MD-TE1	HVINJM2068MDTE1
IC25		HC10102090	HC10102090	IC	NJM2068MD-TE1	HVINJM2068MDTE1
IC26		HC10102090	HC10102090	IC	NJM2068MD-TE1	HVINJM2068MDTE1
IC27		HC10102090	HC10102090	IC	NJM2068MD-TE1	HVINJM2068MDTE1
IC28		*HS27AWH0R	*HS27AWH0R	IC ONE TIME PROM	HD64F2398F20	HVIHD64F2398F20
IC29		HC10099540	HC10099540	IC	S-80145ALMC	HVIS-80145ALMC
IC30		*HC108390R	*HC108390R	IC	AT24C08N10SC2.7	HVIAT24C08N10SC
IC31		HC36J25050	HC36J25050	IC REG	TA48033FTE16	HVITA48033FTE16
IC32		HC36J25050	HC36J25050	IC REG	TA48025FTE16	HVITA48025FTE16
IC33		*HW100680R	*HW100680R	PHOTO UNIT	H11A817B300W	HVIH11A817B
IC34		*HW100690R	*HW100690R	PHOTO UNIT	RPM674CBR-S	BRVRPM6936
JK11		*YJ002680R	*YJ002680R	OPT. CONNECTOR	TORX179L	HJSTORX179L
JK12		*YJ002680R	*YJ002680R	OPT. CONNECTOR	TORX179L	HJSTORX179L
JK13		*YJ002680R	*YJ002680R	OPT. CONNECTOR	TORX179L	HJSTORX179L
JK14		*YT003290R	*YT003290R	TERMINAL	B/B/B , N-PLATE	CJJ4S018Z
JK15		*YT003170R	*YT003170R	TERMINAL	1P,BLACK,SILVER	CJJ4M048Z
JK16		*YJ002670R	*YJ002670R	OPT. CONNECTOR	TOTX179L	HJSTOTX179L
JK17		*YT003120R	*YT003120R	TERMINAL		CJJ4N036Z
JK20		*YT003650R	*YT003650R	TERMINAL	SILVER PLATE	CJJ4N071Z
JK21		*YJ002760R	*YJ002760R	JACK	SR7400	HJJ1D002Z
L101		nsp	NN05000610	CHIP RES.	0Ω	HRJ10DJ0R0T
LC10		nsp	NN05000610	CHIP RES.	0Ω	HRJ10DJ0R0T
LC11		nsp	NN05000610	CHIP RES.	0Ω	HRJ10DJ0R0T
LC12		nsp	NN05000610	CHIP RES.	0Ω	HRJ10DJ0R0T
LC13		nsp	NN05000610	CHIP RES.	0Ω	HRJ10DJ0R0T
LC14		nsp	NN05000610	CHIP RES.	0Ω	HRJ10DJ0R0T
LC15		nsp	NN05000610	CHIP RES.	0Ω	HRJ10DJ0R0T
LC16		nsp	NN05000610	CHIP RES.	0Ω	HRJ10DJ0R0T
LC17		nsp	NN05000610	CHIP RES.	0Ω	HRJ10DJ0R0T
LC18		nsp	NN05000610	CHIP RES.	0Ω	HRJ10DJ0R0T
LC19		nsp	NN05000610	CHIP RES.	0Ω	HRJ10DJ0R0T
LC21		nsp	NN05000610	CHIP RES.	0Ω	HRJ10DJ0R0T
LC22		nsp	NN05000610	CHIP RES.	0Ω	HRJ10DJ0R0T
LC23		nsp	NN05000610	CHIP RES.	0Ω	HRJ10DJ0R0T
LC24		nsp	NN05000610	CHIP RES.	0Ω	HRJ10DJ0R0T
LC25		nsp	NN05000610	CHIP RES.	0Ω	HRJ10DJ0R0T
LC26		nsp	NN05000610	CHIP RES.	0Ω	HRJ10DJ0R0T
LC27		nsp	NN05000610	CHIP RES.	0Ω	HRJ10DJ0R0T
LC28		nsp	NN05000610	CHIP RES.	0Ω	HRJ10DJ0R0T
LC29		nsp	NN05000610	CHIP RES.	0Ω	HRJ10DJ0R0T
LC30		nsp	NN05000610	CHIP RES.	0Ω	HRJ10DJ0R0T
LC31		nsp	NN05000610	CHIP RES.	0Ω	HRJ10DJ0R0T
LC32		nsp	NN05000610	CHIP RES.	0Ω	HRJ10DJ0R0T
LC33		nsp	NN05000610	CHIP RES.	0Ω	HRJ10DJ0R0T
LC34		nsp	NN05000610	CHIP RES.	0Ω	HRJ10DJ0R0T
LC35		nsp	NN05000610	CHIP RES.	0Ω	HRJ10DJ0R0T
LC36		nsp	NN05000610	CHIP RES.	0Ω	HRJ10DJ0R0T
LC37		nsp	NN05000610	CHIP RES.	0Ω	HRJ10DJ0R0T
LC38		nsp	NN05000610	CHIP RES.	0Ω	HRJ10DJ0R0T
LC39		nsp	NN05000610	CHIP RES.	0Ω	HRJ10DJ0R0T
LC40		nsp	NN05000610	CHIP RES.	0Ω	HRJ10DJ0R0T
LC41		nsp	NN05000610	CHIP RES.	0Ω	HRJ10DJ0R0T
LC42		nsp	NN05000610	CHIP RES.	0Ω	HRJ10DJ0R0T
LC43		nsp	NN05000610	CHIP RES.	0Ω	HRJ10DJ0R0T

NOTE : *nsp* PART IS LISTED FOR REFERENCE ONLY, MARANTZ WILL NOT SUPPLY THESE PARTS.

POS. NO	VERS. COLOR	PART NO. (FOR EUR)	PART NO. (MJI)	DESCRIPTION		
LC44		nsp	NN05000610	CHIP RES.	0Ω	HRJ10DJ0R0T
LC45		nsp	NN05000610	CHIP RES.	0Ω	HRJ10DJ0R0T
LC46		nsp	NN05000610	CHIP RES.	0Ω	HRJ10DJ0R0T
LC47		nsp	NN05000610	CHIP RES.	0Ω	HRJ10DJ0R0T
LC48		nsp	NN05000610	CHIP RES.	0Ω	HRJ10DJ0R0T
LC49		nsp	NN05000610	CHIP RES.	0Ω	HRJ10DJ0R0T
LC50		nsp	NN05000610	CHIP RES.	0Ω	HRJ10DJ0R0T
LC51		nsp	NN05000610	CHIP RES.	0Ω	HRJ10DJ0R0T
LC53		nsp	NN05000610	CHIP RES.	0Ω	HRJ10DJ0R0T
LC54		nsp	NN05000610	CHIP RES.	0Ω	HRJ10DJ0R0T
LC55		nsp	NN05000610	CHIP RES.	0Ω	HRJ10DJ0R0T
LC56		nsp	NN05000610	CHIP RES.	0Ω	HRJ10DJ0R0T
LC57		nsp	NN05000610	CHIP RES.	0Ω	HRJ10DJ0R0T
LC58		nsp	NN05000610	CHIP RES.	0Ω	HRJ10DJ0R0T
LC59		nsp	NN05000610	CHIP RES.	0Ω	HRJ10DJ0R0T
LC60		nsp	NN05000610	CHIP RES.	0Ω	HRJ10DJ0R0T
LC61		nsp	NN05000610	CHIP RES.	0Ω	HRJ10DJ0R0T
LC62		nsp	NN05000610	CHIP RES.	0Ω	HRJ10DJ0R0T
LC63		nsp	NN05000610	CHIP RES.	0Ω	HRJ10DJ0R0T
LC64		nsp	NN05000610	CHIP RES.	0Ω	HRJ10DJ0R0T
LC65		nsp	NN05000610	CHIP RES.	0Ω	HRJ10DJ0R0T
LC66		nsp	NN05000610	CHIP RES.	0Ω	HRJ10DJ0R0T
LC67		nsp	NN05000610	CHIP RES.	0Ω	HRJ10DJ0R0T
LC68		nsp	NN05000610	CHIP RES.	0Ω	HRJ10DJ0R0T
LC69		nsp	NN05000610	CHIP RES.	0Ω	HRJ10DJ0R0T
LC70		nsp	NN05000610	CHIP RES.	0Ω	HRJ10DJ0R0T
LC72		nsp	NN05000610	CHIP RES.	0Ω	HRJ10DJ0R0T
LC73		nsp	NN05000610	CHIP RES.	0Ω	HRJ10DJ0R0T
LC76		nsp	NN05000610	CHIP RES.	0Ω	HRJ10DJ0R0T
LC78		nsp	NN05000610	CHIP RES.	0Ω	HRJ10DJ0R0T
LC79		nsp	NN05000610	CHIP RES.	0Ω	HRJ10DJ0R0T
LC80		nsp	NN05000610	CHIP RES.	0Ω	HRJ10DJ0R0T
LC81		nsp	NN05000610	CHIP RES.	0Ω	HRJ10DJ0R0T
Q101		*HX900010R	*HX900010R	TRS.	KTD1304	HVTKTD1304T
Q102		*HX900010R	*HX900010R	TRS.	KTD1304	HVTKTD1304T
Q103		*HX600010R	*HX600010R	TRS.	KRA102S	HVTKRA102S
Q105		*HX600010R	*HX600010R	TRS.	KRA102S	HVTKRA102S
Q106		*HX800010R	*HX800010R	TRS.	KRC102S	HVTKRC102S
Q107		*HX600010R	*HX600010R	TRS.	KRA102S	HVTKRA102S
Q108		*HX600010R	*HX600010R	TRS.	KRA102S	HVTKRA102S
Q109		*HT600020R	*HT600020R	TRS.	KTA1268GR	HVTKTA1268GRT
Q110		*HX800010R	*HX800010R	TRS.	KRC102S	HVTKRC102S
Q111		*HX600010R	*HX600010R	TRS.	KRA102S	HVTKRA102S
Q112		*HX600010R	*HX600010R	TRS.	KRA102S	HVTKRA102S
QC10		*HX600010R	*HX600010R	TRS.	KRA102S	HVTKRA102S
QC11		*HX800010R	*HX800010R	TRS.	KRC102S	HVTKRC102S
QC12		*HX600010R	*HX600010R	TRS.	KRA102S	HVTKRA102S
R101		nsp	NN05100610	CHIP RES.	10Ω	HRJ10DJ100T
R102		nsp	NN05103610	CHIP RES.	10kΩ	HRJ10DJ103T
R103		nsp	NN05100610	CHIP RES.	10Ω	HRJ10DJ100T
R104		nsp	NN05103610	CHIP RES.	10kΩ	HRJ10DJ103T
R105		nsp	NN05100610	CHIP RES.	10Ω	HRJ10DJ100T
R106		nsp	NN05103610	CHIP RES.	10kΩ	HRJ10DJ103T
R107		nsp	NN05750610	CHIP RES.	75Ω	HRJ10DJ750T
R108		nsp	NN05102610	CHIP RES.	1kΩ	HRJ10DJ102T
R109		nsp	NN05104610	CHIP RES.	100kΩ	HRJ10DJ104T
R110		nsp	NN05472610	CHIP RES.	4.7kΩ	HRJ10DJ472T

NOTE : *nsp* PART IS LISTED FOR REFERENCE ONLY, MARANTZ WILL NOT SUPPLY THESE PARTS.

POS. NO	VERS. COLOR	PART NO. (FOR EUR)	PART NO. (MJI)	DESCRIPTION		
R111		nsp	NN05750610	CHIP RES.	75Ω	HRJ10DJ750T
R112		nsp	NN05102610	CHIP RES.	1kΩ	HRJ10DJ102T
R113		nsp	NN05104610	CHIP RES.	100kΩ	HRJ10DJ104T
R114		nsp	NN05472610	CHIP RES.	4.7kΩ	HRJ10DJ472T
R115		nsp	NN05750610	CHIP RES.	75Ω	HRJ10DJ750T
R116		nsp	NN05102610	CHIP RES.	1kΩ	HRJ10DJ102T
R117		nsp	NN05104610	CHIP RES.	100kΩ	HRJ10DJ104T
R118		nsp	NN05472610	CHIP RES.	4.7kΩ	HRJ10DJ472T
R119		nsp	NN05750610	CHIP RES.	75Ω	HRJ10DJ750T
R120		nsp	NN05100610	CHIP RES.	10Ω	HRJ10DJ100T
R121		nsp	NN05750610	CHIP RES.	75Ω	HRJ10DJ750T
R122		nsp	NN05101610	CHIP RES.	100Ω	HRJ10DJ101T
R123		nsp	NN05104610	CHIP RES.	100kΩ	HRJ10DJ104T
R124		nsp	NN05472610	CHIP RES.	4.7kΩ	HRJ10DJ472T
R125		nsp	NN05100610	CHIP RES.	10Ω	HRJ10DJ100T
R126		nsp	NN05100610	CHIP RES.	10Ω	HRJ10DJ100T
R127		nsp	NN05104610	CHIP RES.	100kΩ	HRJ10DJ104T
R128		nsp	NN05472610	CHIP RES.	4.7kΩ	HRJ10DJ472T
R129		nsp	NN05330610	CHIP RES.	33Ω	HRJ10DJ330T
R131		nsp	NN05221610	CHIP RES.	220Ω	HRJ10DJ221T
R132		nsp	NN05101610	CHIP RES.	100Ω	HRJ10DJ101T
R133		nsp	NN05101610	CHIP RES.	100Ω	HRJ10DJ101T
R134		nsp	NN05101610	CHIP RES.	100Ω	HRJ10DJ101T
R135		nsp	NN05101610	CHIP RES.	100Ω	HRJ10DJ101T
R136		nsp	NN05101610	CHIP RES.	100Ω	HRJ10DJ101T
R137		nsp	NN05101610	CHIP RES.	100Ω	HRJ10DJ101T
R138		nsp	NN05101610	CHIP RES.	100Ω	HRJ10DJ101T
R139		nsp	NN05010610	CHIP RES.	1Ω	HRJ10DJ1R0T
R140		nsp	NN05105610	CHIP RES.	1MΩ	HRJ10DJ105T
R141		nsp	NN05103610	CHIP RES.	10kΩ	HRJ10DJ103T
R142		nsp	NN05103610	CHIP RES.	10kΩ	HRJ10DJ103T
R143		nsp	NN05103610	CHIP RES.	10kΩ	HRJ10DJ103T
R144		nsp	NN05103610	CHIP RES.	10kΩ	HRJ10DJ103T
R145		nsp	NN05332610	CHIP RES.	3.3kΩ	HRJ10DJ332T
R146		nsp	NN05223610	CHIP RES.	22kΩ	HRJ10DJ223T
R147		nsp	NN05473610	CHIP RES.	47kΩ	HRJ10DJ473T
R148		nsp	NN05682610	CHIP RES.	6.8kΩ	HRJ10DJ682T
R149		nsp	NN05104610	CHIP RES.	100kΩ	HRJ10DJ104T
R150		nsp	NN05272610	CHIP RES.	2.7kΩ	HRJ10DJ272T
R151		nsp	NN05472610	CHIP RES.	4.7kΩ	HRJ10DJ472T
R152		nsp	NN05472610	CHIP RES.	4.7kΩ	HRJ10DJ472T
R153		nsp	NN05562610	CHIP RES.	5.6kΩ	HRJ10DJ562T
R154		nsp	NN05472610	CHIP RES.	4.7kΩ	HRJ10DJ472T
R155		nsp	NN05101610	CHIP RES.	100Ω	HRJ10DJ101T
R156		nsp	NN05101610	CHIP RES.	100Ω	HRJ10DJ101T
R157		nsp	NN05682610	CHIP RES.	6.8kΩ	HRJ10DJ682T
R158		nsp	NN05104610	CHIP RES.	100kΩ	HRJ10DJ104T
R159		nsp	NN05272610	CHIP RES.	2.7kΩ	HRJ10DJ272T
R160		nsp	NN05472610	CHIP RES.	4.7kΩ	HRJ10DJ472T
R161		nsp	NN05472610	CHIP RES.	4.7kΩ	HRJ10DJ472T
R162		nsp	NN05562610	CHIP RES.	5.6kΩ	HRJ10DJ562T
R163		nsp	NN05472610	CHIP RES.	4.7kΩ	HRJ10DJ472T
R164		nsp	NN05101610	CHIP RES.	100Ω	HRJ10DJ101T
R165		nsp	NN05101610	CHIP RES.	100Ω	HRJ10DJ101T
R166		nsp	NN05222610	CHIP RES.	2.2kΩ	HRJ10DJ222T
R167		nsp	NN05222610	CHIP RES.	2.2kΩ	HRJ10DJ222T
R168		nsp	NN05105610	CHIP RES.	1MΩ	HRJ10DJ105T

NOTE : *nsp* PART IS LISTED FOR REFERENCE ONLY, MARANTZ WILL NOT SUPPLY THESE PARTS.

POS. NO	VERS. COLOR	PART NO. (FOR EUR)	PART NO. (MJ)	DESCRIPTION		
R169		nsp	NN05101610	CHIP RES.	100Ω	HRJ10DJ101T
R170		nsp	NN05562610	CHIP RES.	5.6kΩ	HRJ10DJ562T
R171		nsp	NN05103610	CHIP RES.	10kΩ	HRJ10DJ103T
R172		nsp	NN05270610	CHIP RES.	27Ω	HRJ10DJ270T
R173		nsp	NN05563610	CHIP RES.	56kΩ	HRJ10DJ563T
R174		nsp	NN05330610	CHIP RES.	33Ω	HRJ10DJ330T
R175		nsp	NN05330610	CHIP RES.	33Ω	HRJ10DJ330T
R176		nsp	NN05330610	CHIP RES.	33Ω	HRJ10DJ330T
R177		nsp	NN05330610	CHIP RES.	33Ω	HRJ10DJ330T
R178		nsp	NN05103610	CHIP RES.	10kΩ	HRJ10DJ103T
R179		nsp	NN05103610	CHIP RES.	10kΩ	HRJ10DJ103T
R180		nsp	NN05103610	CHIP RES.	10kΩ	HRJ10DJ103T
R181		nsp	NN05103610	CHIP RES.	10kΩ	HRJ10DJ103T
R182		nsp	NN05103610	CHIP RES.	10kΩ	HRJ10DJ103T
R183		nsp	NN05103610	CHIP RES.	10kΩ	HRJ10DJ103T
R184		nsp	NN05152610	CHIP RES.	1.5kΩ	HRJ10DJ152T
R185		nsp	NN05103610	CHIP RES.	10kΩ	HRJ10DJ103T
R186		nsp	NN05103610	CHIP RES.	10kΩ	HRJ10DJ103T
R187		nsp	NN05103610	CHIP RES.	10kΩ	HRJ10DJ103T
R188		nsp	NN05103610	CHIP RES.	10kΩ	HRJ10DJ103T
R189		nsp	NN05562610	CHIP RES.	5.6kΩ	HRJ10DJ562T
R190		nsp	NN05103610	CHIP RES.	10kΩ	HRJ10DJ103T
R191		nsp	NN05103610	CHIP RES.	10kΩ	HRJ10DJ103T
R192		nsp	NN05103610	CHIP RES.	10kΩ	HRJ10DJ103T
R193		nsp	NN05332610	CHIP RES.	3.3kΩ	HRJ10DJ332T
R194		nsp	NN05103610	CHIP RES.	10kΩ	HRJ10DJ103T
R195		nsp	NN05562610	CHIP RES.	5.6kΩ	HRJ10DJ562T
R196		nsp	NN05332610	CHIP RES.	3.3kΩ	HRJ10DJ332T
R197		nsp	NN05332610	CHIP RES.	3.3kΩ	HRJ10DJ332T
R198		nsp	NN05332610	CHIP RES.	3.3kΩ	HRJ10DJ332T
R199		nsp	NN05103610	CHIP RES.	10kΩ	HRJ10DJ103T
R200		nsp	NN05103610	CHIP RES.	10kΩ	HRJ10DJ103T
R201		nsp	NN05103610	CHIP RES.	10kΩ	HRJ10DJ103T
R202		nsp	NN05332610	CHIP RES.	3.3kΩ	HRJ10DJ332T
R203		nsp	NN05332610	CHIP RES.	3.3kΩ	HRJ10DJ332T
R204		nsp	NN05103610	CHIP RES.	10kΩ	HRJ10DJ103T
R205		nsp	NN05103610	CHIP RES.	10kΩ	HRJ10DJ103T
R206		nsp	NN05562610	CHIP RES.	5.6kΩ	HRJ10DJ562T
R207		nsp	NN05332610	CHIP RES.	3.3kΩ	HRJ10DJ332T
R208		nsp	NN05103610	CHIP RES.	10kΩ	HRJ10DJ103T
R209		nsp	NN05103610	CHIP RES.	10kΩ	HRJ10DJ103T
R210		nsp	NN05103610	CHIP RES.	10kΩ	HRJ10DJ103T
R211		nsp	NN05103610	CHIP RES.	10kΩ	HRJ10DJ103T
R212		nsp	NN05103610	CHIP RES.	10kΩ	HRJ10DJ103T
R213		nsp	NN05103610	CHIP RES.	10kΩ	HRJ10DJ103T
R214		nsp	NN05103610	CHIP RES.	10kΩ	HRJ10DJ103T
R215		nsp	NN05103610	CHIP RES.	10kΩ	HRJ10DJ103T
R216		nsp	NN05103610	CHIP RES.	10kΩ	HRJ10DJ103T
R217		nsp	NN05103610	CHIP RES.	10kΩ	HRJ10DJ103T
R218		nsp	NN05103610	CHIP RES.	10kΩ	HRJ10DJ103T
R219		nsp	NN05103610	CHIP RES.	10kΩ	HRJ10DJ103T
R220		nsp	NN05103610	CHIP RES.	10kΩ	HRJ10DJ103T
R221		nsp	NN05103610	CHIP RES.	10kΩ	HRJ10DJ103T
R222		nsp	NN05103610	CHIP RES.	10kΩ	HRJ10DJ103T
R223		nsp	NN05103610	CHIP RES.	10kΩ	HRJ10DJ103T
R224		nsp	NN05103610	CHIP RES.	10kΩ	HRJ10DJ103T
R225		nsp	NN05103610	CHIP RES.	10kΩ	HRJ10DJ103T

NOTE : "nsp" PART IS LISTED FOR REFERENCE ONLY, MARANTZ WILL NOT SUPPLY THESE PARTS.

POS. NO	VERS. COLOR	PART NO. (FOR EUR)	PART NO. (MJI)	DESCRIPTION		
R226		nsp	NN05103610	CHIP RES.	10kΩ	HRJ10DJ103T
R227		nsp	NN05103610	CHIP RES.	10kΩ	HRJ10DJ103T
R228		nsp	NN05103610	CHIP RES.	10kΩ	HRJ10DJ103T
R229		nsp	NN05103610	CHIP RES.	10kΩ	HRJ10DJ103T
R230		nsp	NN05103610	CHIP RES.	10kΩ	HRJ10DJ103T
R231		nsp	NN05103610	CHIP RES.	10kΩ	HRJ10DJ103T
R232		nsp	NN05103610	CHIP RES.	10kΩ	HRJ10DJ103T
R233		nsp	NN05103610	CHIP RES.	10kΩ	HRJ10DJ103T
R234		nsp	NN05103610	CHIP RES.	10kΩ	HRJ10DJ103T
R235		nsp	NN05103610	CHIP RES.	10kΩ	HRJ10DJ103T
R236		nsp	NN05103610	CHIP RES.	10kΩ	HRJ10DJ103T
R237		nsp	NN05103610	CHIP RES.	10kΩ	HRJ10DJ103T
R238		nsp	NN05103610	CHIP RES.	10kΩ	HRJ10DJ103T
R239		nsp	NN05330610	CHIP RES.	33Ω	HRJ10DJ330T
R240		nsp	NN05103610	CHIP RES.	10kΩ	HRJ10DJ103T
R241		nsp	NN05330610	CHIP RES.	33Ω	HRJ10DJ330T
R242		nsp	NN05330610	CHIP RES.	33Ω	HRJ10DJ330T
R243		nsp	NN05330610	CHIP RES.	33Ω	HRJ10DJ330T
R244		nsp	NN05223610	CHIP RES.	22kΩ	HRJ10DJ223T
R245		nsp	NN05223610	CHIP RES.	22kΩ	HRJ10DJ223T
R246		nsp	NN05223610	CHIP RES.	22kΩ	HRJ10DJ223T
R247		nsp	NN05392610	CHIP RES.	3.9kΩ	HRJ10DJ392T
R248		nsp	NN05392610	CHIP RES.	3.9kΩ	HRJ10DJ392T
R249		nsp	NN05822610	CHIP RES.	8.2kΩ	HRJ10DJ822T
R250		nsp	NN05182610	CHIP RES.	1.8kΩ	HRJ10DJ182T
R251		nsp	NN05822610	CHIP RES.	8.2kΩ	HRJ10DJ822T
R252		nsp	NN05182610	CHIP RES.	1.8kΩ	HRJ10DJ182T
R253		nsp	NN05101610	CHIP RES.	100Ω	HRJ10DJ101T
R254		nsp	NN05104610	CHIP RES.	100kΩ	HRJ10DJ104T
R255		nsp	NN05392610	CHIP RES.	3.9kΩ	HRJ10DJ392T
R256		nsp	NN05392610	CHIP RES.	3.9kΩ	HRJ10DJ392T
R257		nsp	NN05822610	CHIP RES.	8.2kΩ	HRJ10DJ822T
R258		nsp	NN05182610	CHIP RES.	1.8kΩ	HRJ10DJ182T
R259		nsp	NN05822610	CHIP RES.	8.2kΩ	HRJ10DJ822T
R260		nsp	NN05182610	CHIP RES.	1.8kΩ	HRJ10DJ182T
R261		nsp	NN05101610	CHIP RES.	100Ω	HRJ10DJ101T
R262		nsp	NN05104610	CHIP RES.	100kΩ	HRJ10DJ104T
R263		nsp	NN05392610	CHIP RES.	3.9kΩ	HRJ10DJ392T
R264		nsp	NN05392610	CHIP RES.	3.9kΩ	HRJ10DJ392T
R265		nsp	NN05822610	CHIP RES.	8.2kΩ	HRJ10DJ822T
R266		nsp	NN05182610	CHIP RES.	1.8kΩ	HRJ10DJ182T
R267		nsp	NN05822610	CHIP RES.	8.2kΩ	HRJ10DJ822T
R268		nsp	NN05182610	CHIP RES.	1.8kΩ	HRJ10DJ182T
R269		nsp	NN05101610	CHIP RES.	100Ω	HRJ10DJ101T
R270		nsp	NN05104610	CHIP RES.	100kΩ	HRJ10DJ104T
R271		nsp	NN05392610	CHIP RES.	3.9kΩ	HRJ10DJ392T
R272		nsp	NN05392610	CHIP RES.	3.9kΩ	HRJ10DJ392T
R273		nsp	NN05822610	CHIP RES.	8.2kΩ	HRJ10DJ822T
R274		nsp	NN05182610	CHIP RES.	1.8kΩ	HRJ10DJ182T
R275		nsp	NN05822610	CHIP RES.	8.2kΩ	HRJ10DJ822T
R276		nsp	NN05182610	CHIP RES.	1.8kΩ	HRJ10DJ182T
R277		nsp	NN05101610	CHIP RES.	100Ω	HRJ10DJ101T
R278		nsp	NN05104610	CHIP RES.	100kΩ	HRJ10DJ104T
R279		nsp	NN05392610	CHIP RES.	3.9kΩ	HRJ10DJ392T
R280		nsp	NN05392610	CHIP RES.	3.9kΩ	HRJ10DJ392T
R281		nsp	NN05822610	CHIP RES.	8.2kΩ	HRJ10DJ822T
R282		nsp	NN05182610	CHIP RES.	1.8kΩ	HRJ10DJ182T

NOTE : *nsp* PART IS LISTED FOR REFERENCE ONLY, MARANTZ WILL NOT SUPPLY THESE PARTS.

POS. NO	VERS. COLOR	PART NO. (FOR EUR)	PART NO. (MJJ)	DESCRIPTION		
R283		nsp	NN05822610	CHIP RES.	8.2kΩ	HRJ10DJ822T
R284		nsp	NN05182610	CHIP RES.	1.8kΩ	HRJ10DJ182T
R285		nsp	NN05101610	CHIP RES.	100Ω	HRJ10DJ101T
R286		nsp	NN05104610	CHIP RES.	100kΩ	HRJ10DJ104T
R287		nsp	NN05392610	CHIP RES.	3.9kΩ	HRJ10DJ392T
R288		nsp	NN05392610	CHIP RES.	3.9kΩ	HRJ10DJ392T
R289		nsp	NN05822610	CHIP RES.	8.2kΩ	HRJ10DJ822T
R290		nsp	NN05182610	CHIP RES.	1.8kΩ	HRJ10DJ182T
R291		nsp	NN05822610	CHIP RES.	8.2kΩ	HRJ10DJ822T
R292		nsp	NN05182610	CHIP RES.	1.8kΩ	HRJ10DJ182T
R293		nsp	NN05101610	CHIP RES.	100Ω	HRJ10DJ101T
R294		nsp	NN05104610	CHIP RES.	100kΩ	HRJ10DJ104T
R295		nsp	NN05392610	CHIP RES.	3.9kΩ	HRJ10DJ392T
R296		nsp	NN05392610	CHIP RES.	3.9kΩ	HRJ10DJ392T
R297		nsp	NN05822610	CHIP RES.	8.2kΩ	HRJ10DJ822T
R298		nsp	NN05182610	CHIP RES.	1.8kΩ	HRJ10DJ182T
R299		nsp	NN05822610	CHIP RES.	8.2kΩ	HRJ10DJ822T
R300		nsp	NN05182610	CHIP RES.	1.8kΩ	HRJ10DJ182T
R301		nsp	NN05101610	CHIP RES.	100Ω	HRJ10DJ101T
R302		nsp	NN05104610	CHIP RES.	100kΩ	HRJ10DJ104T
R303		nsp	NN05470610	CHIP RES.	47Ω	HRJ10DJ470T
R304		nsp	NN05221610	CHIP RES.	220Ω	HRJ10DJ221T
R305		nsp	NN05473610	CHIP RES.	47kΩ	HRJ10DJ473T
R306		nsp	NN05473610	CHIP RES.	47kΩ	HRJ10DJ473T
R307		nsp	NN05152610	CHIP RES.	1.5kΩ	HRJ10DJ152T
R308		nsp	NN05221610	CHIP RES.	220Ω	HRJ10DJ221T
R309		nsp	NN05183610	CHIP RES.	18kΩ	HRJ10DJ183T
R310		nsp	NN05470610	CHIP RES.	47Ω	HRJ10DJ470T
R311		nsp	NN05220610	CHIP RES.	22Ω	HRJ10DJ220T
R312		nsp	NN05103610	CHIP RES.	10kΩ	HRJ10DJ103T
R313		nsp	NN05223610	CHIP RES.	22kΩ	HRJ10DJ223T
R314		nsp	NN05682610	CHIP RES.	6.8kΩ	HRJ10DJ682T
R315		nsp	NN05047610	CHIP RES.	4.7Ω	HRJ10DJ4R7T
R316		nsp	NN05102610	CHIP RES.	1kΩ	HRJ10DJ102T
R318		nsp	NN05201610	CHIP RES.	200Ω	HRJ10DJ201T
R319		nsp	NN05101610	CHIP RES.	100Ω	HRJ10DJ101T
R320		nsp	NN05101610	CHIP RES.	100Ω	HRJ10DJ101T
R321		nsp	NN05392610	CHIP RES.	3.9kΩ	HRJ10DJ392T
R322		nsp	NN05392610	CHIP RES.	3.9kΩ	HRJ10DJ392T
R323		nsp	NN05822610	CHIP RES.	8.2kΩ	HRJ10DJ822T
R324		nsp	NN05182610	CHIP RES.	1.8kΩ	HRJ10DJ182T
R325		nsp	NN05182610	CHIP RES.	1.8kΩ	HRJ10DJ182T
R326		nsp	NN05822610	CHIP RES.	8.2kΩ	HRJ10DJ822T
R327		nsp	NN05101610	CHIP RES.	100Ω	HRJ10DJ101T
R328		nsp	NN05104610	CHIP RES.	100kΩ	HRJ10DJ104T
R329		nsp	NN05201610	CHIP RES.	200Ω	HRJ10DJ201T
R330		nsp	NN05220610	CHIP RES.	22Ω	HRJ10DJ220T
R331		nsp	NN05047610	CHIP RES.	4.7Ω	HRJ10DJ4R7T
RC11		nsp	NN05103610	CHIP RES.	10kΩ	HRJ10DJ103T
RC12		nsp	NN05562610	CHIP RES.	5.6kΩ	HRJ10DJ562T
RC13		nsp	NN05223610	CHIP RES.	22kΩ	HRJ10DJ223T
RC14		nsp	NN05473610	CHIP RES.	47kΩ	HRJ10DJ473T
RC15		nsp	NN05473610	CHIP RES.	47kΩ	HRJ10DJ473T
RC16		nsp	NN05473610	CHIP RES.	47kΩ	HRJ10DJ473T
RC17		nsp	NN05473610	CHIP RES.	47kΩ	HRJ10DJ473T
RC18		nsp	NN05473610	CHIP RES.	47kΩ	HRJ10DJ473T
RC19		nsp	NN05473610	CHIP RES.	47kΩ	HRJ10DJ473T

NOTE : "nsp" PART IS LISTED FOR REFERENCE ONLY, MARANTZ WILL NOT SUPPLY THESE PARTS.

POS. NO	VERS. COLOR	PART NO. (FOR EUR)	PART NO. (MJ)	DESCRIPTION	
BK82		nsp	nsp	BRACKET	CMD1A387
BN11		nsp	nsp	CONN. CORD	CWB1B907230EN
BN12		nsp	nsp	CONN. CORD	CWB1B905340EN
BN14		nsp	nsp	CONN. CORD	CWB1B907370EN
BN17		nsp	nsp	CONN. CORD	CWB1C905370EN
BN40	/F/K/L/N/U	nsp	nsp	CONN. CORD	CWB1B906220EN
BN40	/S	nsp	nsp	CONN. CORD	CWB1B906170EN
BN85		nsp	nsp	CONN. CORD	CWB1B902320EN
BN92		nsp	nsp	CONN. CORD	CWZSR5400BN92
C801		nsp	OA10701020	ELECT. CAP. 100pF 10V	HCEA1AH101T
C802		nsp	OA10601620	ELECT. CAP. 10µF 16V	HCEA1CH100T
C804		nsp	nsp	CER. CAP. 0.01µF 50V Z	HCBS1H103ZFT
C805		nsp	nsp	CER. CAP. 100pF 50V K	HCBS1H101KBT
C806		nsp	OA10701620	ELECT. CAP. 100µF 16V	HCEA1CH101T
C807		nsp	nsp	CER. CAP. 100pF 50V K	HCBS1H101KBT
C809		nsp	nsp	CER. CAP. 100pF 50V K	HCBS1H101KBT
C810		nsp	nsp	CER. CAP. 100pF 50V K	HCBS1H101KBT
C811		nsp	nsp	CER. CAP. 100pF 50V K	HCBS1H101KBT
C812		nsp	nsp	CER. CAP. 100pF 50V K	HCBS1H101KBT
C813		nsp	OA47601050	ELECT. CAP. 47µF 10V	HCEA1AH470T
C814		nsp	nsp	CER. CAP. 100pF 50V K	HCBS1H101KBT
C815		nsp	nsp	CER. CAP. 100pF 50V K	HCBS1H101KBT
C816		nsp	nsp	CER. CAP. 100pF 50V K	HCBS1H101KBT
C817		nsp	nsp	CER. CAP. 100pF 50V K	HCBS1H101KBT
C818		nsp	nsp	CER. CAP. 100pF 50V K	HCBS1H101KBT
C820		nsp	nsp	CER. CAP. 100pF 50V K	HCBS1H101KBT
C821		nsp	OA10605020	ELECT. CAP. 10µF 50V KBS	HCEA1HKS100T
C822		nsp	nsp	CER. CAP. 100pF 50V K	HCBS1H101KBT
C824		nsp	nsp	CER. CAP. 0.1µF 50V Z	HCBS1H104ZFT
C825		nsp	nsp	CER. CAP. 390pF 50V K	HCBS1H391KBT
C826		nsp	nsp	CER. CAP. 100pF 50V K	HCBS1H101KBT
C827		nsp	nsp	CER. CAP. 100pF 50V K	HCBS1H101KBT
C828		nsp	OA10701020	ELECT. CAP. 100µF 10V	HCEA1AKS101T
C829		nsp	OA10601620	ELECT. CAP. 10µF 16V	HCEA1CH100T
C830		nsp	OA10601620	ELECT. CAP. 10µF 16V	HCEA1CH100T
C831		nsp	OA10601620	ELECT. CAP. 10µF 16V	HCEA1CH100T
C832		nsp	OA10601620	ELECT. CAP. 10µF 16V	HCEA1CH100T
C833		nsp	nsp	CER. CAP. 0.1µF 50V Z	HCBS1H104ZFT
C834		nsp	nsp	CER. CAP. 47pF 50V J	HCBS1H470JT
C835		nsp	nsp	CER. CAP. 47pF 50V J	HCBS1H470JT
C836		nsp	nsp	CER. CAP. 0.1µF 50V Z	HCBS1H104ZFT
C837		nsp	nsp	CER. CAP. 1000pF 50V B	HCBS1H102KBT
C838		nsp	nsp	CER. CAP. 1000pF 50V B	HCBS1H102KBT
C840		nsp	nsp	CER. CAP. 0.1µF 50V Z	HCBS1H104ZFT
C841		nsp	nsp	CER. CAP. 0.1µF 50V Z	HCBS1H104ZFT
C846		nsp	nsp	CER. CAP. 0.01µF 50V Z	HCBS1H103ZFT
C847		nsp	OA47601640	ELECT. CAP. 47µF 16V	HCEA1CH470T
C848		nsp	nsp	CER. CAP. 0.1µF 50V Z	HCBS1H104ZFT
C849	/F/U	nsp	nsp	CER. CAP. 0.1µF 50V Z	HCBS1H104ZFT
C871		nsp	nsp	CER. CAP. 0.01µF 50V Z	HCBS1H103ZFT
C872		nsp	nsp	CER. CAP. 0.01µF 50V Z	HCBS1H103ZFT
C873		nsp	nsp	CER. CAP. 0.01µF 50V Z	HCBS1H103ZFT
C874		nsp	nsp	CER. CAP. 100pF 50V KB	CCKT1H101KB
C875		nsp	nsp	CER. CAP. 100pF 50V KB	CCKT1H101KB
C876		nsp	nsp	CER. CAP. 0.1µF 50V Z	HCBS1H104ZFT
 C877	/F/K/N/S	nsp	*DK100800R	CER. CAP. DKS471ME	KCKDKS471ME
C881		nsp	nsp	CER. CAP. 0.1µF 50V Z	HCBS1H104ZFT

NOTE : "nsp" PART IS LISTED FOR REFERENCE ONLY, MARANTZ WILL NOT SUPPLY THESE PARTS.

POS. NO	VERS. COLOR	PART NO. (FOR EUR)	PART NO. (MJI)	DESCRIPTION		
C882		nsp	OA47505020	ELECT. CAP.	4.7µF 50V	HCEA1HH4R7T
C883		nsp	OA10701620	ELECT. CAP.	100µF 16V	HCEA1CH101T
C884		nsp	nsp	CER. CAP.	0.1µF 50V Z	HCBS1H104ZFT
C885		nsp	nsp	CER. CAP.	0.1µF 50V Z	HCBS1H104ZFT
C886		nsp	OA33802520	ELECT. CAP.	3300µF 25V	HCEA1EH332E
C887		nsp	nsp	CER. CAP.	1000pF 50V B	HCBS1H102KBT
C888		nsp	*DK100810R	CER. CAP.	JP DE1610-610F103M	BCKWKH103MF
C890		nsp	nsp	CER. CAP.	0.1µF 50V Z	HCBS1H104ZFT
C891		nsp	nsp	CER. CAP.	0.1µF 50V Z	HCBS1H104ZFT
C901		nsp	nsp	CER. CAP.	0.1µF 50V Z	HCBS1H104ZFT
C902		nsp	nsp	CER. CAP.	0.1µF 50V Z	HCBS1H104ZFT
C903		nsp	nsp	CER. CAP.	0.1µF 50V Z	HCBS1H104ZFT
C904		nsp	nsp	CER. CAP.	0.1µF 50V Z	HCBS1H104ZFT
C905		nsp	nsp	CER. CAP.	0.1µF 50V Z	HCBS1H104ZFT
CN15		nsp	nsp	JACK	GF102-16S-TS	KJP16GA117ZG
CN81		nsp	nsp	JACK	SR7400	KJP08GB145ZP
CN86		nsp	nsp	JACK	SR7400	KJP08GB144ZP
CN88	/F/K/N/S	YP04000760	YP04000760	JACK	MOLEX35328-02	KJP02GA89ZM
CN90		nsp	nsp	JACK		KJP05GB99ZM
CN91	/F/K/N/S	YP04000760	YP04000760	JACK	MOLEX35328-02	KJP02GA89ZM
CN92		YP04000760	YP04000760	JACK	MOLEX35328-02	KJP02GA89ZM
CN93		YP04000760	YP04000760	JACK	MOLEX35328-02	KJP02GA89ZM
D801		*HI101090R	*HI101090R	L.E.D.	SPR-39MVW3	HVDSPR39MVW3
D802		nsp	HD20015210	DIODE	1SS133T-77	HVD1SS133MT
D803		nsp	nsp	JUMPER	SN95/PB5 , 0.6	C3A206
D804		nsp	*HD201750R	DIODE	TW 1N4003	KVD1N4003SRT
D805		nsp	nsp	JUMPER	SN95/PB5 , 0.6	C3A206
D806		HD30821000	HD30821000	ZENER DIODE	8.2V 1/2W	HVDMTZJ8.2BT
▲ D807		*HD201750R	*HD201750R	DIODE	TW 1N4003	KVD1N4003SRT
▲ D808		*HD201750R	*HD201750R	DIODE	TW 1N4003	KVD1N4003SRT
▲ D809		*HD201750R	*HD201750R	DIODE	TW 1N4003	KVD1N4003SRT
▲ D810		*HD201750R	*HD201750R	DIODE	TW 1N4003	KVD1N4003SRT
▲ D811		*HD201750R	*HD201750R	DIODE	TW 1N4003	KVD1N4003SRT
▲ D812		*HD201750R	*HD201750R	DIODE	TW 1N4003	KVD1N4003SRT
D813		*HD201750R	*HD201750R	DIODE	TW 1N4003	KVD1N4003SRT
D820		*HD301940R	*HD301940R	ZENER DIODE	3.3V 1/2W	HVDMTZJ3.3BT
EN81		*SR000240R	*SR000240R	ROTARY SWITCH	EC16B243040HB	HSR2A004Z
EN82		*SR000180R	*SR000180R	ROTARY SWITCH	EC16B12S00D4ZZZ	HSR2A019Z
F801		nsp	nsp	FUSE HOLDER		KJCFCS5S
▲ F802	/F/L/N/U	*FS001070R	*FS001070R	FUSE		KBA2D2500TLET
▲ F803	/F/L/U	nsp	*FS001070R	FUSE		KBA2D2500TLET
FIP1		*HQ300620R	*HQ300620R	DISPLAY	16-BT-110GNK	HFL16BT110GNK
IC12		HC700400Z0	HC700400Z0	IC	TC74HCU04AFN	HVITC74HCU04AFN
IC81		HC10220090	HC10220090	IC		HVINJU3430F
IC83		HC10053090	HC10053090	IC	NJM2068DD	HVINJM2068DD
IC84		*HC108410R	*HC108410R	IC	S-80842CNY-X	HVIS-80842CNY
▲ IC85		*HC300500R	*HC300500R	IC REG.	KA7805-ABTU	HVIMC7805C
IC91		*HC108440R	*HC108440R	IC	ST202EBW	HVIST202EBW
J106						
J		nsp	nsp	JUMPER	SN95/PB5 , 0.6	C3A206
J810						
J816	/F/U	nsp	nsp	JUMPER	SN95/PB5 , 0.6	C3A206
J817		nsp	nsp	JUMPER	SN95/PB5 , 0.6	C3A206
J818		nsp	nsp	JUMPER	SN95/PB5 , 0.6	C3A206
J820		nsp	nsp	JUMPER	SN95/PB5 , 0.6	C3A206
J821		nsp	nsp	JUMPER	SN95/PB5 , 0.6	C3A206
J822	/L/U	nsp	nsp	JUMPER	SN95/PB5 , 0.6	C3A206

NOTE : *nsp* PART IS LISTED FOR REFERENCE ONLY, MARANTZ WILL NOT SUPPLY THESE PARTS.

POS. NO	VERS. COLOR	PART NO. (FOR EUR)	PART NO. (MJI)	DESCRIPTION		
J823	/L/U	nsp	nsp	JUMPER	SN95/PB5 , 0.6	C3A206
J825		nsp	nsp	JUMPER	SN95/PB5 , 0.6	C3A206
J828		nsp	nsp	JUMPER	SN95/PB5 , 0.6	C3A206
J829		nsp	nsp	JUMPER	SN95/PB5 , 0.6	C3A206
J830		nsp	nsp	JUMPER	SN95/PB5 , 0.6	C3A206
J831	/L/U	nsp	nsp	JUMPER	SN95/PB5 , 0.6	C3A206
J834		nsp	nsp	JUMPER	SN95/PB5 , 0.6	C3A206
J840		nsp	nsp	JUMPER	SN95/PB5 , 0.6	C3A206
J850	/K/L/N/S/U	nsp	nsp	JUMPER	SN95/PB5 , 0.6	C3A206
JK81		*YT003160R	*YT003160R	TERMINAL		CJJ2E020Z
JK83		*YT003240R	*YT003240R	TERMINAL		CJJ9M004Z
JK84		*YT003220R	*YT003220R	TERMINAL	ADVR-7100	CJJ4S028Z
▲ JK86	/F/L/U	nsp	*YT002410R	OUTLET	A204D0041P	KJJ7A015Z
▲ JK86	/N	*YT002430R	*YT002430R	OUTLET	A302D0061P	KJJ7A022Z
JK87		*YJ002680R	*YJ002680R	OPT. CONNECTOR	TORX179L	HJSTORX179L
JK91		*YT003300R	*YT003300R	TERMINAL		KJP09TA87WM
JW11		nsp	nsp	CONN. CORD		CWE8102180RV
JW12		nsp	nsp	CONN. CORD		CWE8102050RV
JW13		nsp	nsp	CONN. CORD		CWE8102150RV
L801		LY10090010	LY10090010	RELAY	SDT-S-109DMR	HSL1D016ZE
Q801		BA10004000	BA10004000	TRS.	KRA111M	HVTKRA111MT
Q802		BA10004000	BA10004000	TRS.	KRA111M	HVTKRA111MT
Q803		HT30001000	HT30001000	TRS.	KTC3199YT	HVTKTC3199YT
Q804		BA20004000	BA20004000	TRS.	KRC111M	HVTKRC111MT
Q805		*HT600040R	*HT600040R	TRS.	KTA1267YT	HVTKTA1267YT
Q806		BA10004000	BA10004000	TRS.	KRA111M	HVTKRA111MT
R802		nsp	nsp	JUMPER	SN95/PB5 , 0.6	C3A206
R803		nsp	nsp	JUMPER	SN95/PB5 , 0.6	C3A206
R805		nsp	nsp	RES.	47Ω 1/6W J	CRD20TJ470T
R806		nsp	nsp	RES.	10kΩ 1/6W J	CRD20TJ103T
R807		nsp	nsp	RES.	10kΩ 1/6W J	CRD20TJ103T
R808		nsp	nsp	RES.	10kΩ 1/6W J	CRD20TJ103T
R809		nsp	nsp	RES.	10kΩ 1/6W J	CRD20TJ103T
R810		nsp	nsp	RES.	5.6kΩ 1/6W J	CRD20TJ562T
R811		nsp	nsp	RES.	2.7kΩ 1/6W J	CRD20TJ272T
R812		nsp	nsp	RES.	2.2kΩ 1/6W J	CRD20TJ222T
R813		nsp	nsp	RES.	1.5kΩ 1/6W J	CRD20TJ152T
R814		nsp	nsp	RES.	1kΩ 1/6W J	CRD20TJ102T
R815		nsp	nsp	RES.	820Ω 1/6W J	CRD20TJ821T
R816		nsp	nsp	RES.	560Ω 1/6W J	CRD20TJ561T
R817		nsp	nsp	RES.	680Ω 1/6W J	CRD20TJ681T
R818		nsp	nsp	RES.	5.6kΩ 1/6W J	CRD20TJ562T
R819		nsp	nsp	RES.	2.7kΩ 1/6W J	CRD20TJ272T
R820		nsp	nsp	RES.	2.2kΩ 1/6W J	CRD20TJ222T
R821		nsp	nsp	RES.	1.5kΩ 1/6W J	CRD20TJ152T
R822		nsp	nsp	RES.	1kΩ 1/6W J	CRD20TJ102T
R823		nsp	nsp	RES.	820Ω 1/6W J	CRD20TJ821T
R824		nsp	nsp	RES.	560Ω 1/6W J	CRD20TJ561T
R825		nsp	nsp	RES.	680Ω 1/6W J	CRD20TJ681T
R826		nsp	nsp	RES.	5.6kΩ 1/6W J	CRD20TJ562T
R827		nsp	nsp	RES.	2.7kΩ 1/6W J	CRD20TJ272T
R828		nsp	nsp	RES.	2.2kΩ 1/6W J	CRD20TJ222T
R829		nsp	nsp	RES.	1.5kΩ 1/6W J	CRD20TJ152T
R830		nsp	nsp	RES.	1kΩ 1/6W J	CRD20TJ102T
R831		nsp	nsp	RES.	10kΩ 1/6W J	CRD20TJ103T
R833		nsp	nsp	RES.	68kΩ 1/6W J	CRD20TJ683T
R834		nsp	nsp	RES.	47kΩ 1/6W J	CRD20TJ473T

NOTE : "nsp" PART IS LISTED FOR REFERENCE ONLY, MARANTZ WILL NOT SUPPLY THESE PARTS.

POS. NO	VERS. COLOR	PART NO. (FOR EUR)	PART NO. (MJI)	DESCRIPTION		
R835		nsp	nsp	RES.	47kΩ 1/6W J	CRD20TJ473T
R836		nsp	nsp	RES.	47kΩ 1/6W J	CRD20TJ473T
R837		nsp	nsp	RES.	47kΩ 1/6W J	CRD20TJ473T
R838		nsp	nsp	RES.	100Ω 1/6W J	CRD20TJ101T
R839		nsp	nsp	RES.	100Ω 1/6W J	CRD20TJ101T
R840		nsp	nsp	JUMPER	SN95/PB5 , 0.6	C3A206
R841		nsp	nsp	RES.	75Ω 1/6W J	CRD20TJ750T
R842		nsp	nsp	JUMPER	SN95/PB5 , 0.6	C3A206
R843		nsp	nsp	RES.	75Ω 1/6W J	CRD20TJ750T
R844		nsp	nsp	RES.	75Ω 1/6W J	CRD20TJ750T
R845		nsp	nsp	RES.	100Ω 1/6W J	CRD20TJ101T
R846		nsp	nsp	RES.	4.7kΩ 1/6W J	CRD20TJ472T
R847		nsp	nsp	RES.	470Ω 1/6W J	CRD20TJ471T
R851		nsp	nsp	RES.	10Ω 1/6W J	CRD20TJ100T
R852		nsp	nsp	RES.	10kΩ 1/6W J	CRD20TJ103T
R853		nsp	nsp	RES.	100kΩ 1/6W J	CRD20TJ104T
R854		nsp	nsp	RES.	4.7kΩ 1/6W J	CRD20TJ472T
R855		nsp	nsp	JUMPER	SN95/PB5 , 0.6	C3A206
R856		nsp	nsp	JUMPER	SN95/PB5 , 0.6	C3A206
R857		nsp	nsp	RES.	220Ω 1/6W J	CRD20TJ221T
R859		nsp	nsp	RES.	330Ω 1/6W J	CRD20TJ331T
R871		nsp	nsp	RES.	10kΩ 1/6W J	CRD20TJ103T
R872		nsp	nsp	RES.	10kΩ 1/6W J	CRD20TJ103T
R873		nsp	nsp	RES.	10kΩ 1/6W J	CRD20TJ103T
R874		nsp	nsp	RES.	10kΩ 1/6W J	CRD20TJ103T
R875		nsp	nsp	RES.	680Ω 1/6W J	CRD20TJ681T
R876		nsp	nsp	RES.	820Ω 1/6W J	CRD20TJ821T
R877		nsp	nsp	RES.	560Ω 1/6W J	CRD20TJ561T
R878	/F/K/N/S	nsp	nsp	RES.	680Ω 1/6W J	CRD20TJ681T
R878	/L/U	nsp	nsp	JUMPER	SN95/PB5 , 0.6	C3A206
R879	/F/K/N/S	nsp	nsp	JUMPER	SN95/PB5 , 0.6	C3A206
R879	/L/U	nsp	nsp	RES.	680Ω 1/6W J	CRD20TJ681T
R881		nsp	nsp	RES.	47kΩ 1/6W J	CRD20TJ473T
R882		nsp	nsp	RES.	10kΩ 1/6W J	CRD20TJ103T
R883		nsp	nsp	RES.	2.2kΩ 1/6W J	CRD20TJ222T
R885		nsp	nsp	RES.	1Ω 1/6W J	CRD20TJ1R0T
 R886	/U	nsp	*GG000010R	RES.	JP 3.3MΩ 1/2W	BRDERC12UGK335T
R887		nsp	nsp	RES.	4.7kΩ 1/6W J	CRD20TJ472T
R888		nsp	nsp	RES.	10kΩ 1/6W J	CRD20TJ103T
R901		nsp	nsp	RES.	10kΩ 1/6W J	CRD20TJ103T
R902		nsp	nsp	RES.	10kΩ 1/6W J	CRD20TJ103T
R903		nsp	nsp	RES.	10kΩ 1/6W J	CRD20TJ103T
R904		nsp	nsp	RES.	10kΩ 1/6W J	CRD20TJ103T
R905		nsp	nsp	RES.	10kΩ 1/6W J	CRD20TJ103T
R906		nsp	nsp	RES.	10kΩ 1/6W J	CRD20TJ103T
R907		nsp	nsp	RES.	10kΩ 1/6W J	CRD20TJ103T
R908		nsp	nsp	RES.	10kΩ 1/6W J	CRD20TJ103T
R909		nsp	nsp	RES.	10kΩ 1/6W J	CRD20TJ103T
R910		nsp	nsp	RES.	10kΩ 1/6W J	CRD20TJ103T
R911		nsp	nsp	RES.	10kΩ 1/6W J	CRD20TJ103T
R912		nsp	nsp	RES.	10kΩ 1/6W J	CRD20TJ103T
R913		nsp	nsp	RES.	10kΩ 1/6W J	CRD20TJ103T
R914		nsp	nsp	RES.	10kΩ 1/6W J	CRD20TJ103T
R915		nsp	nsp	RES.	10kΩ 1/6W J	CRD20TJ103T
R916		nsp	nsp	RES.	10kΩ 1/6W J	CRD20TJ103T
R917		nsp	nsp	RES.	47kΩ 1/6W J	CRD20TJ473T
R918		nsp	nsp	RES.	47kΩ 1/6W J	CRD20TJ473T

NOTE : *nsp* PART IS LISTED FOR REFERENCE ONLY, MARANTZ WILL NOT SUPPLY THESE PARTS.

POS. NO	VERS. COLOR	PART NO. (FOR EUR)	PART NO. (MJ)	DESCRIPTION		
R919		nsp	nsp	RES.	47kΩ 1/6W J	CRD20TJ473T
R920		nsp	nsp	RES.	47kΩ 1/6W J	CRD20TJ473T
R921		nsp	nsp	RES.	47kΩ 1/6W J	CRD20TJ473T
R922		nsp	nsp	RES.	47kΩ 1/6W J	CRD20TJ473T
R923		nsp	nsp	RES.	47kΩ 1/6W J	CRD20TJ473T
R924		nsp	nsp	RES.	47kΩ 1/6W J	CRD20TJ473T
R925		nsp	nsp	RES.	47kΩ 1/6W J	CRD20TJ473T
R926		nsp	nsp	RES.	47kΩ 1/6W J	CRD20TJ473T
R927		nsp	nsp	RES.	47kΩ 1/6W J	CRD20TJ473T
R928		nsp	nsp	RES.	47kΩ 1/6W J	CRD20TJ473T
R929		nsp	nsp	RES.	47kΩ 1/6W J	CRD20TJ473T
R930		nsp	nsp	RES.	47kΩ 1/6W J	CRD20TJ473T
R931		nsp	nsp	RES.	47kΩ 1/6W J	CRD20TJ473T
R932		nsp	nsp	RES.	47kΩ 1/6W J	CRD20TJ473T
R933		nsp	nsp	RES.	47kΩ 1/6W J	CRD20TJ473T
R934		nsp	nsp	RES.	47kΩ 1/6W J	CRD20TJ473T
R935		nsp	nsp	RES.	47kΩ 1/6W J	CRD20TJ473T
R936		nsp	nsp	RES.	47kΩ 1/6W J	CRD20TJ473T
R937		nsp	nsp	RES.	47kΩ 1/6W J	CRD20TJ473T
R938		nsp	nsp	RES.	47kΩ 1/6W J	CRD20TJ473T
R939		nsp	nsp	RES.	47kΩ 1/6W J	CRD20TJ473T
R940		nsp	nsp	RES.	47kΩ 1/6W J	CRD20TJ473T
R941		nsp	nsp	RES.	47kΩ 1/6W J	CRD20TJ473T
R942		nsp	nsp	RES.	47kΩ 1/6W J	CRD20TJ473T
R943		nsp	nsp	RES.	47kΩ 1/6W J	CRD20TJ473T
R944		nsp	nsp	RES.	47kΩ 1/6W J	CRD20TJ473T
R945		nsp	nsp	RES.	47kΩ 1/6W J	CRD20TJ473T
R946		nsp	nsp	RES.	47kΩ 1/6W J	CRD20TJ473T
R947		nsp	nsp	RES.	47kΩ 1/6W J	CRD20TJ473T
R948		nsp	nsp	RES.	47kΩ 1/6W J	CRD20TJ473T
R949		nsp	nsp	RES.	47kΩ 1/6W J	CRD20TJ473T
R950		nsp	nsp	RES.	47kΩ 1/6W J	CRD20TJ473T
R951		nsp	nsp	RES.	47kΩ 1/6W J	CRD20TJ473T
R952		nsp	nsp	RES.	47kΩ 1/6W J	CRD20TJ473T
R953		nsp	nsp	RES.	47kΩ 1/6W J	CRD20TJ473T
RC81		*HW100650R	*HW100650R	PHOTO UNIT	RPM6936-H4	HRVRPM6936H4
SW71		*SP001210R	*SP001210R	SWITCH	SKHV10910G	CST1A012ZT
SW72		*SP001210R	*SP001210R	SWITCH	SKHV10910G	CST1A012ZT
SW73		*SP001210R	*SP001210R	SWITCH	SKHV10910G	CST1A012ZT
SW74		*SP001210R	*SP001210R	SWITCH	SKHV10910G	CST1A012ZT
SW75		*SP001210R	*SP001210R	SWITCH	SKHV10910G	CST1A012ZT
SW76	U	nsp	*SP001210R	SWITCH	SKHV10910G	CST1A012ZT
SW77		*SP001210R	*SP001210R	SWITCH	SKHV10910G	CST1A012ZT
SW78		*SP001210R	*SP001210R	SWITCH	SKHV10910G	CST1A012ZT
SW79		*SP001210R	*SP001210R	SWITCH	SKHV10910G	CST1A012ZT
SW80		*SP001210R	*SP001210R	SWITCH	SKHV10910G	CST1A012ZT
SW81		*SP001210R	*SP001210R	SWITCH	SKHV10910G	CST1A012ZT
SW82		*SP001210R	*SP001210R	SWITCH	SKHV10910G	CST1A012ZT
SW83		*SP001210R	*SP001210R	SWITCH	SKHV10910G	CST1A012ZT
SW84		*SP001210R	*SP001210R	SWITCH	SKHV10910G	CST1A012ZT
SW85		*SP001210R	*SP001210R	SWITCH	SKHV10910G	CST1A012ZT
SW86		*SP001210R	*SP001210R	SWITCH	SKHV10910G	CST1A012ZT
SW87		*SP001210R	*SP001210R	SWITCH	SKHV10910G	CST1A012ZT
SW88		*SP001210R	*SP001210R	SWITCH	SKHV10910G	CST1A012ZT
SW89		*SP001210R	*SP001210R	SWITCH	SKHV10910G	CST1A012ZT
SW90		*SP001210R	*SP001210R	SWITCH	SKHV10910G	CST1A012ZT
SW91		*SP001210R	*SP001210R	SWITCH	SKHV10910G	CST1A012ZT

NOTE : "nsp" PART IS LISTED FOR REFERENCE ONLY, MARANTZ WILL NOT SUPPLY THESE PARTS.

POS. NO	VERS. COLOR	PART NO. (FOR EUR)	PART NO. (MJI)	DESCRIPTION		
SW92		*SP001210R	*SP001210R	SWITCH	SKHV10910G	CST1A012ZT
SW93		*SP001210R	*SP001210R	SWITCH	SKHV10910G	CST1A012ZT
SW94		*SP001210R	*SP001210R	SWITCH	SKHV10910G	CST1A012ZT
SW95		*SP001210R	*SP001210R	SWITCH	SKHV10910G	CST1A012ZT
SW96	/L/U	nsp	*SP001210R	SWITCH	SKHV10910G	CST1A012ZT
▲ SW97	/F/K/N/S	*SP000850R	*SP000850R	SWITCH	CN JPP1197CSA64	KSH1A001ZV
▲ T801	/K	nsp	*TS001950R	SUB TRANSF.	SR5400(6400)/K1	CLT5I002ZH
▲ T801	/L	nsp	*TS002090R	SUB TRANSF.	SR5400(6400)/L1	CLT5I002ZS
▲ T801	/N/S	*TS001940R	*TS001940R	SUB TRANSF.	SR5400(6400)/N1	CLT5I002ZE
▲ T801	/U	nsp	*TS001970R	SUB TRANSF.	SR5400(6400)/U1	CLT5I002ZU
				INPUT PCB (CUP11657-1), TUNER PCB		
BN22		nsp	nsp	CONN. CORD		CWB1B915280EN
BN29		nsp	nsp	CONN. CORD		CWB1C908450EN
BN30		nsp	nsp	CONN. CORD		CWB1C909130EN
BN31		nsp	nsp	CONN. CORD		CWB1B907120EN
BN32	/F	nsp	nsp	CONN. CORD		CWB1B903200EN
C201		nsp	nsp	CER. CAP.	470pF 50V KB	CCKT1H471KB
C202		nsp	nsp	CER. CAP.	470pF 50V KB	CCKT1H471KB
C203		nsp	nsp	CER. CAP.	470pF 50V KB	CCKT1H471KB
C204		nsp	nsp	CER. CAP.	470pF 50V KB	CCKT1H471KB
C205		nsp	nsp	CER. CAP.	470pF 50V KB	CCKT1H471KB
C206		nsp	nsp	CER. CAP.	470pF 50V KB	CCKT1H471KB
C207		nsp	nsp	CER. CAP.	470pF 50V KB	CCKT1H471KB
C208		nsp	nsp	CER. CAP.	470pF 50V KB	CCKT1H471KB
C209		nsp	nsp	CER. CAP.	470pF 50V KB	CCKT1H471KB
C210		nsp	nsp	CER. CAP.	470pF 50V KB	CCKT1H471KB
C211		nsp	nsp	CER. CAP.	470pF 50V KB	CCKT1H471KB
C212		nsp	nsp	CER. CAP.	470pF 50V KB	CCKT1H471KB
C213		nsp	nsp	CER. CAP.	470pF 50V KB	CCKT1H471KB
C214		nsp	nsp	CER. CAP.	470pF 50V KB	CCKT1H471KB
C215		nsp	nsp	CER. CAP.	470pF 50V KB	CCKT1H471KB
C216		nsp	nsp	CER. CAP.	470pF 50V KB	CCKT1H471KB
C217		nsp	nsp	CER. CAP.	470pF 50V KB	CCKT1H471KB
C218		nsp	nsp	CER. CAP.	470pF 50V KB	CCKT1H471KB
C219		nsp	nsp	CER. CAP.	470pF 50V KB	CCKT1H471KB
C220		nsp	nsp	CER. CAP.	470pF 50V KB	CCKT1H471KB
C221		nsp	nsp	CER. CAP.	470pF 50V KB	CCKT1H471KB
C222		nsp	nsp	CER. CAP.	470pF 50V KB	CCKT1H471KB
C223		nsp	OA10605020	ELECT. CAP.	10µF 50V	HCEA1HH100T
C224		nsp	OA10605020	ELECT. CAP.	10µF 50V	HCEA1HH100T
C225		nsp	OA10605020	ELECT. CAP.	10µF 50V	HCEA1HH100T
C226		nsp	OA10605020	ELECT. CAP.	10µF 50V	HCEA1HH100T
C227		nsp	OA10605020	ELECT. CAP.	10µF 50V	HCEA1HH100T
C228		nsp	OA10605020	ELECT. CAP.	10µF 50V	HCEA1HH100T
C229		nsp	OA10605020	ELECT. CAP.	10µF 50V	HCEA1HH100T
C230		nsp	OA10605020	ELECT. CAP.	10µF 50V	HCEA1HH100T
C231		nsp	nsp	CER. CAP.	470pF 50V KB	CCKT1H471KB
C232		nsp	nsp	CER. CAP.	470pF 50V KB	CCKT1H471KB
C233		nsp	nsp	CER. CAP.	470pF 50V KB	CCKT1H471KB
C234		nsp	nsp	CER. CAP.	470pF 50V KB	CCKT1H471KB
C235		nsp	nsp	CER. CAP.	470pF 50V KB	CCKT1H471KB
C236		nsp	nsp	CER. CAP.	470pF 50V KB	CCKT1H471KB
C237		nsp	nsp	CER. CAP.	470pF 50V KB	CCKT1H471KB
C238		nsp	OA10605020	ELECT. CAP.	10µF 50V	HCEA1HH100T
C239		nsp	OA10605020	ELECT. CAP.	10µF 50V	HCEA1HH100T

NOTE : *nsp* PART IS LISTED FOR REFERENCE ONLY, MARANTZ WILL NOT SUPPLY THESE PARTS.

POS. NO	VERS. COLOR	PART NO. (FOR EUR)	PART NO. (MJI)	DESCRIPTION		
C240		nsp	OA10605020	ELECT. CAP.	10µF 50V	HCEA1HH100T
C241		nsp	OA10605020	ELECT. CAP.	10µF 50V	HCEA1HH100T
C242		nsp	OA10605020	ELECT. CAP.	10µF 50V	HCEA1HH100T
C243		nsp	OA10605020	ELECT. CAP.	10µF 50V	HCEA1HH100T
C244		nsp	OA10605020	ELECT. CAP.	10µF 50V	HCEA1HH100T
C245		nsp	nsp	CER. CAP.	50V 0.1µF	CCKT1H104ZF
C246		nsp	nsp	CER. CAP.	50V 0.1µF	CCKT1H104ZF
C247		nsp	nsp	CER. CAP.	50V 0.1µF	CCKT1H104ZF
C248		nsp	nsp	CER. CAP.	50V 0.1µF	CCKT1H104ZF
C249		nsp	nsp	CER. CAP.	50V 0.1µF	CCKT1H104ZF
C250		nsp	nsp	CER. CAP.	50V 0.1µF	CCKT1H104ZF
C251		nsp	nsp	CER. CAP.	50V 0.1µF	CCKT1H104ZF
C252		nsp	nsp	CER. CAP.	50V 0.1µF	CCKT1H104ZF
C254		nsp	OA10605020	ELECT. CAP.	10µF 50V	HCEA1HH100T
C256		nsp	OA10605020	ELECT. CAP.	10µF 50V	HCEA1HH100T
C258		nsp	OA10605020	ELECT. CAP.	10µF 50V	HCEA1HH100T
C260		nsp	OA10605020	ELECT. CAP.	10µF 50V	HCEA1HH100T
C262		nsp	OA10605020	ELECT. CAP.	10µF 50V	HCEA1HH100T
C264		nsp	OA10605020	ELECT. CAP.	10µF 50V	HCEA1HH100T
C266		nsp	OA10605020	ELECT. CAP.	10µF 50V	HCEA1HH100T
C267		nsp	nsp	CER. CAP.	50V 0.1µF	CCKT1H104ZF
C268		nsp	nsp	CER. CAP.	50V 0.1µF	CCKT1H104ZF
C269		nsp	nsp	CER. CAP.	100pF 50V KB	CCKT1H101KB
C270		nsp	nsp	CER. CAP.	50V 0.1µF	CCKT1H104ZF
C271		nsp	nsp	CER. CAP.	50V 0.1µF	CCKT1H104ZF
C272		nsp	nsp	CER. CAP.	100pF 50V KB	CCKT1H101KB
C273		nsp	nsp	CER. CAP.	50V 0.1µF	CCKT1H104ZF
C274		nsp	nsp	CER. CAP.	50V 0.1µF	CCKT1H104ZF
C275		nsp	nsp	CER. CAP.	50V 0.1µF	CCKT1H104ZF
C276		nsp	nsp	CER. CAP.	50V 0.1µF	CCKT1H104ZF
C281		nsp	OA10605020	ELECT. CAP.	10µF 50V	HCEA1HH100T
C282		nsp	OA10605020	ELECT. CAP.	10µF 50V	HCEA1HH100T
C283		nsp	OA10605020	ELECT. CAP.	10µF 50V	HCEA1HH100T
C284		nsp	OA10605020	ELECT. CAP.	10µF 50V	HCEA1HH100T
C285		nsp	OA10605020	ELECT. CAP.	10µF 50V	HCEA1HH100T
C286		nsp	OA10605020	ELECT. CAP.	10µF 50V	HCEA1HH100T
C287		nsp	OA10605020	ELECT. CAP.	10µF 50V	HCEA1HH100T
C288		nsp	OA10605020	ELECT. CAP.	10µF 50V	HCEA1HH100T
C289		nsp	nsp	CER. CAP.	50V 0.1µF	CCKT1H104ZF
C290		nsp	nsp	CER. CAP.	50V 0.1µF	CCKT1H104ZF
C291		nsp	nsp	CER. CAP.	100pF 50V KB	CCKT1H101KB
C292		nsp	OA22605020	ELECT. CAP.	22µF 50V	HCEA1HH220T
C293		nsp	OA22605020	ELECT. CAP.	22µF 50V	HCEA1HH220T
C294		nsp	OA22605020	ELECT. CAP.	22µF 50V	HCEA1HH220T
C295		nsp	OA22605020	ELECT. CAP.	22µF 50V	HCEA1HH220T
C296		nsp	OA22605020	ELECT. CAP.	22µF 50V	HCEA1HH220T
C297		nsp	OA22605020	ELECT. CAP.	22µF 50V	HCEA1HH220T
C298		nsp	OA22605020	ELECT. CAP.	22µF 50V	HCEA1HH220T
C299		nsp	OA47602520	ELECT. CAP.	47µF 25V	HCEA1EH470T
C300		nsp	OA47602520	ELECT. CAP.	47µF 25V	HCEA1EH470T
C301		nsp	OA47602520	ELECT. CAP.	47µF 25V	HCEA1EH470T
C302		nsp	OA47602520	ELECT. CAP.	47µF 25V	HCEA1EH470T
C303		nsp	nsp	CER. CAP.	50V 0.1µF	CCKT1H104ZF
C304		nsp	nsp	CER. CAP.	50V 0.1µF	CCKT1H104ZF
C305		nsp	nsp	CER. CAP.	50V 0.1µF	CCKT1H104ZF
C306		nsp	nsp	CER. CAP.	50V 0.1µF	CCKT1H104ZF
C307		nsp	nsp	CER. CAP.	100pF 50V KB	CCKT1H101KB

NOTE : "nsp" PART IS LISTED FOR REFERENCE ONLY, MARANTZ WILL NOT SUPPLY THESE PARTS.

POS. NO	VERS. COLOR	PART NO. (FOR EUR)	PART NO. (MJI)	DESCRIPTION		
C308		nsp	nsp	CER. CAP.	100pF 50V KB	CCKT1H101KB
C309		nsp	nsp	CER. CAP.	50V 0.1µF	CCKT1H104ZF
C310		nsp	nsp	CER. CAP.	50V 0.1µF	CCKT1H104ZF
C311		nsp	nsp	CER. CAP.	50V 0.1µF	CCKT1H104ZF
C312		nsp	nsp	CER. CAP.	50V 0.1µF	CCKT1H104ZF
C313		nsp	nsp	CER. CAP.	50V 0.1µF	CCKT1H104ZF
C314		nsp	nsp	CER. CAP.	50V 0.1µF	CCKT1H104ZF
C315		nsp	nsp	CER. CAP.	50V 0.1µF	CCKT1H104ZF
C316		nsp	nsp	CER. CAP.	50V 0.1µF	CCKT1H104ZF
C317		nsp	nsp	CER. CAP.	100pF 50V KB	CCKT1H101KB
C318		nsp	nsp	CER. CAP.	100pF 50V KB	CCKT1H101KB
C319		nsp	nsp	CER. CAP.	100pF 50V KB	CCKT1H101KB
C320		nsp	nsp	CER. CAP.	100pF 50V KB	CCKT1H101KB
C321		nsp	nsp	CER. CAP.	100pF 50V KB	CCKT1H101KB
C322		nsp	nsp	CER. CAP.	100pF 50V KB	CCKT1H101KB
C323		nsp	nsp	CER. CAP.	100pF 50V KB	CCKT1H101KB
C324		nsp	nsp	CER. CAP.	470pF 50V KB	CCKT1H471KB
C325		nsp	nsp	CER. CAP.	470pF 50V KB	CCKT1H471KB
C326		nsp	nsp	CER. CAP.	470pF 50V KB	CCKT1H471KB
C327		nsp	nsp	CER. CAP.	470pF 50V KB	CCKT1H471KB
C328		nsp	nsp	CER. CAP.	470pF 50V KB	CCKT1H471KB
C329		nsp	OA10605020	ELECT. CAP.	10µF 50V	HCEA1HH100T
C330		nsp	OA10605020	ELECT. CAP.	10µF 50V	HCEA1HH100T
C331		nsp	OA10605020	ELECT. CAP.	10µF 50V	HCEA1HH100T
C332		nsp	OA10605020	ELECT. CAP.	10µF 50V	HCEA1HH100T
C333		nsp	OA10605020	ELECT. CAP.	10µF 50V	HCEA1HH100T
C334		nsp	OA10605020	ELECT. CAP.	10µF 50V	HCEA1HH100T
C335		nsp	OA10605020	ELECT. CAP.	10µF 50V	HCEA1HH100T
C336		nsp	OA22605020	ELECT. CAP.	22µF 50V	HCEA1HH220T
C337		nsp	OA22605020	ELECT. CAP.	22µF 50V	HCEA1HH220T
C338		nsp	OA22605020	ELECT. CAP.	22µF 50V	HCEA1HH220T
C339		nsp	OA22605020	ELECT. CAP.	22µF 50V	HCEA1HH220T
C340		nsp	OA22605020	ELECT. CAP.	22µF 50V	HCEA1HH220T
C341		nsp	OA22605020	ELECT. CAP.	22µF 50V	HCEA1HH220T
C342		nsp	OA22605020	ELECT. CAP.	22µF 50V	HCEA1HH220T
C343		nsp	OA47602520	ELECT. CAP.	47µF 25V	HCEA1EH470T
C344		nsp	OA47602520	ELECT. CAP.	47µF 25V	HCEA1EH470T
C345		nsp	OA47602520	ELECT. CAP.	47µF 25V	HCEA1EH470T
C346		nsp	OA47602520	ELECT. CAP.	47µF 25V	HCEA1EH470T
C347		nsp	OA47602520	ELECT. CAP.	47µF 25V	HCEA1EH470T
C348		nsp	OA47602520	ELECT. CAP.	47µF 25V	HCEA1EH470T
C349		nsp	OA47602520	ELECT. CAP.	47µF 25V	HCEA1EH470T
C350		nsp	nsp	CER. CAP.	100pF 50V KB	CCKT1H101KB
C351		nsp	nsp	CER. CAP.	100pF 50V KB	CCKT1H101KB
C354		nsp	nsp	CER. CAP.	100pF 50V KB	CCKT1H101KB
C355		nsp	nsp	CER. CAP.	100pF 50V KB	CCKT1H101KB
C356		nsp	nsp	CER. CAP.	100pF 50V KB	CCKT1H101KB
C357		nsp	nsp	CER. CAP.	100pF 50V KB	CCKT1H101KB
C358		nsp	nsp	CER. CAP.	0.01µF 50V ZF	CCKT1H103ZF
C359		nsp	nsp	CER. CAP.	50V 0.1µF	CCKT1H104ZF
C360		nsp	nsp	CER. CAP.	0.01µF 50V ZF	CCKT1H103ZF
C361		nsp	nsp	CER. CAP.	50V 0.1µF	CCKT1H104ZF
C362		nsp	OA10701620	ELECT. CAP.	100µF 16V	HCEA1CH101T
C363		nsp	OA10701620	ELECT. CAP.	100µF 16V	HCEA1CH101T
C364		nsp	nsp	CER. CAP.	50V 0.1µF	CCKT1H104ZF
C365		nsp	nsp	CER. CAP.	50V 0.1µF	CCKT1H104ZF
C366		nsp	nsp	CER. CAP.	50V 0.1µF	CCKT1H104ZF

NOTE : *nsp* PART IS LISTED FOR REFERENCE ONLY, MARANTZ WILL NOT SUPPLY THESE PARTS.

POS. NO	VERS. COLOR	PART NO. (FOR EUR)	PART NO. (MJI)	DESCRIPTION		
C367		nsp	nsp	CER. CAP.	50V 0.1µF	CCKT1H104ZF
C368		nsp	nsp	CER. CAP.	50V 0.1µF	CCKT1H104ZF
C369		nsp	OA10701620	ELECT. CAP.	100µF 16V	HCEA1CH101T
C370		nsp	OA10701620	ELECT. CAP.	100µF 16V	HCEA1CH101T
C371		nsp	OA10701620	ELECT. CAP.	100µF 16V	HCEA1CH101T
C372		nsp	OA10701620	ELECT. CAP.	100µF 16V	HCEA1CH101T
C373		nsp	OA10701620	ELECT. CAP.	100µF 16V	HCEA1CH101T
C374		nsp	nsp	CER. CAP.	470pF 50V KB	CCKT1H471KB
C375		nsp	nsp	CER. CAP.	470pF 50V KB	CCKT1H471KB
C376		nsp	OA22605020	ELECT. CAP.	22µF 50V	HCEA1HH220T
C377		nsp	nsp	CER. CAP.	470pF 50V KB	CCKT1H471KB
C378		nsp	nsp	CER. CAP.	470pF 50V KB	CCKT1H471KB
C379		nsp	OA10605020	ELECT. CAP.	10µF 50V	HCEA1HH100T
C380		nsp	OA10605020	ELECT. CAP.	10µF 50V	HCEA1HH100T
C381		nsp	nsp	CER. CAP.	50V 0.1µF	CCKT1H104ZF
C382		nsp	nsp	CER. CAP.	50V 0.1µF	CCKT1H104ZF
C386		nsp	nsp	CER. CAP.	0.01µF 50V ZF	CCKT1H103ZF
C387		nsp	nsp	CER. CAP.	0.01µF 50V ZF	CCKT1H103ZF
C388		nsp	nsp	CER. CAP.	0.01µF 50V ZF	CCKT1H103ZF
C389		nsp	nsp	CER. CAP.	0.01µF 50V ZF	CCKT1H103ZF
C390		nsp	nsp	CER. CAP.	0.01µF 50V ZF	CCKT1H103ZF
C393		nsp	nsp	CER. CAP.	50V 0.1µF	CCKT1H104ZF
C394		nsp	OA10701620	ELECT. CAP.	100µF 16V	HCEA1CH101T
C395		nsp	nsp	CER. CAP.	50V 0.1µF	CCKT1H104ZF
C396		nsp	OA10701620	ELECT. CAP.	100µF 16V	HCEA1CH101T
C397 /F		nsp	nsp	CER. CAP.	470pF 50V KB	CCKT1H471KB
C398 /F		nsp	nsp	CER. CAP.	470pF 50V KB	CCKT1H471KB
C403		nsp	nsp	CER. CAP.	470pF 50V KB	CCKT1H471KB
C404		nsp	OA10605020	ELECT. CAP.	10µF 50V	HCEA1HH100T
C406		nsp	OA10605020	ELECT. CAP.	10µF 50V	HCEA1HH100T
C407		nsp	nsp	CER. CAP.	50V 0.1µF	CCKT1H104ZF
C408		nsp	OA10605020	ELECT. CAP.	10µF 50V	HCEA1HH100T
C409		nsp	OA10605020	ELECT. CAP.	10µF 50V	HCEA1HH100T
C412		nsp	OA10605020	ELECT. CAP.	10µF 50V	HCEA1HH100T
C413		nsp	OA10605020	ELECT. CAP.	10µF 50V	HCEA1HH100T
C414		nsp	nsp	CER. CAP.	50V 0.1µF	CCKT1H104ZF
C415		nsp	OA22605020	ELECT. CAP.	22µF 50V	HCEA1HH220T
C416		nsp	OA22605020	ELECT. CAP.	22µF 50V	HCEA1HH220T
C417		nsp	OA10605020	ELECT. CAP.	10µF 50V	HCEA1HH100T
C418		nsp	OA10605020	ELECT. CAP.	10µF 50V	HCEA1HH100T
C419		nsp	OA22605020	ELECT. CAP.	22µF 50V	HCEA1HH220T
C420		nsp	OA22605020	ELECT. CAP.	22µF 50V	HCEA1HH220T
C421		nsp	nsp	CER. CAP.	100pF 50V KB	CCKT1H101KB
C423		nsp	OA47602520	ELECT. CAP.	47µF 25V	HCEA1EH470T
C424		nsp	OA47602520	ELECT. CAP.	47µF 25V	HCEA1EH470T
C425		nsp	nsp	CER. CAP.	470pF 50V KB	CCKT1H471KB
C426		nsp	nsp	CER. CAP.	470pF 50V KB	CCKT1H471KB
C427		nsp	OA10605020	ELECT. CAP.	10µF 50V	HCEA1HH100T
C428		nsp	OA22605020	ELECT. CAP.	22µF 50V	HCEA1HH220T
C429		nsp	nsp	CER. CAP.	100pF 50V KB	CCKT1H101KB
C430		nsp	OA47602520	ELECT. CAP.	47µF 25V	HCEA1EH470T
C431		nsp	nsp	CER. CAP.	470pF 50V KB	CCKT1H471KB
C432		nsp	nsp	CER. CAP.	50V 0.1µF	CCKT1H104ZF
C433		nsp	nsp	CER. CAP.	50V 0.1µF	CCKT1H104ZF
C434		nsp	nsp	CER. CAP.	100pF 50V KB	CCKT1H101KB
C442		nsp	nsp	CER. CAP.	100pF 50V KB	CCKT1H101KB
CN11		nsp	nsp	JACK	MOLEX53014-0710	KJP07GA19ZM

NOTE : "nsp" PART IS LISTED FOR REFERENCE ONLY, MARANTZ WILL NOT SUPPLY THESE PARTS.

POS. NO	VERS. COLOR	PART NO. (FOR EUR)	PART NO. (MJI)	DESCRIPTION		
CN21		nsp	nsp	JACK	MOLEX53014-0610	KJP06GA19ZM
CN23		nsp	nsp	JACK	MOLEX 5267-08A	KJP08GA01ZM
CN24		nsp	nsp	JACK	MOLEX53014-0610	KJP06GA19ZM
CN25		nsp	nsp	JACK		KJP19GA117ZG
CN27	/F/L/U	nsp	nsp	JACK	GF120-15S-TS	KJP15GA115ZG
CN27	/K/N/S	nsp	nsp	JACK	GF120-17S-TS	KJP17GA115ZG
CN32	/F	nsp	nsp	JACK		KJP03GA19ZM
D203		nsp	HD20015210	DIODE	1SS133T-77	HVD1SS133MT
D205		nsp	HD20015210	DIODE	1SS133T-77	HVD1SS133MT
D206		nsp	HD20015210	DIODE	1SS133T-77	HVD1SS133MT
D207		nsp	HD20015210	DIODE	1SS133T-77	HVD1SS133MT
D208		nsp	HD20015210	DIODE	1SS133T-77	HVD1SS133MT
D209		nsp	HD20015210	DIODE	1SS133T-77	HVD1SS133MT
D210		nsp	HD20015210	DIODE	1SS133T-77	HVD1SS133MT
D211		nsp	HD20015210	DIODE	1SS133T-77	HVD1SS133MT
D212		nsp	HD20015210	DIODE	1SS133T-77	HVD1SS133MT
D213		nsp	*HD201730R	DIODE	1N4003	KVD1N4003ST
D214		nsp	*HD201730R	DIODE	1N4003	KVD1N4003ST
ET21		nsp	nsp	TERMINAL		CNE75
IC21		HC10470050	HC10470050	IC	TC9164AN	HVITC9164AN
IC22		HC10468050	HC10468050	IC	TC9273N	HVITC9273N
IC23		HC10469050	HC10469050	IC	TC9162AN	HVITC9162AN
IC24		HC10467050	HC10467050	IC	TC9499N	HVITC9499N
IC25		HC10467050	HC10467050	IC	TC9499N	HVITC9499N
IC26		*HC300550R	*HC300550R	IC REG		HVIMC7806
IC27		*HC300540R	*HC300540R	IC REG	KA7906	HVIKA7906
IC28		HC10053090	HC10053090	IC	NJM2068DD	HVINJM2068DD
IC29		HC10053090	HC10053090	IC	NJM2068DD	HVINJM2068DD
IC30		HC10053090	HC10053090	IC	NJM2068DD	HVINJM2068DD
IC31		HC10053090	HC10053090	IC	NJM2068DD	HVINJM2068DD
IC32		HC10053090	HC10053090	IC	NJM2068DD	HVINJM2068DD
IC33		HC10053090	HC10053090	IC	NJM2068DD	HVINJM2068DD
IC34		HC10053090	HC10053090	IC	NJM2068DD	HVINJM2068DD
IC35		HC10053090	HC10053090	IC	NJM2068DD	HVINJM2068DD
IC36		HC10053090	HC10053090	IC	NJM2068DD	HVINJM2068DD
IC37		HC10053090	HC10053090	IC	NJM2068DD	HVINJM2068DD
IC38		HC10468050	HC10468050	IC	TC9273N	HVITC9273N
IC40		HC10053090	HC10053090	IC	NJM2068DD	HVINJM2068DD
IC41		HC10053090	HC10053090	IC	NJM2068DD	HVINJM2068DD
J001	/K/N/S/U	nsp	nsp	JUMPER	SN95/PB5 , 0.6	C3A206
J002						
∫		nsp	nsp	JUMPER	SN95/PB5 , 0.6	C3A206
J999						
JK21		*YT002960R	*YT002960R	JACK		CJJ4R019Z
JK22		*YT002960R	*YT002960R	JACK		CJJ4R019Z
JK23		*YT002960R	*YT002960R	JACK		CJJ4R019Z
JK24		*YT002960R	*YT002960R	JACK		CJJ4R019Z
JK25		*YT003660R	*YT003660R	JACK	SILVER PLATE	CJJ4P045Z
JK26		*YT003660R	*YT003660R	JACK	SILVER PLATE	CJJ4P045Z
JK27	/F	nsp	*YT003180R	JACK		CJJ4N063Z
Q201		HT805501B0	HT805501B0	TRS.	KTC2874B	HVTKTC2874BT
Q202		HT805501B0	HT805501B0	TRS.	KTC2874B	HVTKTC2874BT
Q203		HT805501B0	HT805501B0	TRS.	KTC2874B	HVTKTC2874BT
Q204		HT805501B0	HT805501B0	TRS.	KTC2874B	HVTKTC2874BT
Q205		HT805501B0	HT805501B0	TRS.	KTC2874B	HVTKTC2874BT
Q206		HT805501B0	HT805501B0	TRS.	KTC2874B	HVTKTC2874BT
Q207		HT805501B0	HT805501B0	TRS.	KTC2874B	HVTKTC2874BT

NOTE : *nsp* PART IS LISTED FOR REFERENCE ONLY, MARANTZ WILL NOT SUPPLY THESE PARTS.

POS. NO	VERS. COLOR	PART NO. (FOR EUR)	PART NO. (MJJ)	DESCRIPTION		
Q208		HT805501B0	HT805501B0	TRS.	KTC2874B	HVTKTC2874BT
Q209		HT805501B0	HT805501B0	TRS.	KTC2874B	HVTKTC2874BT
Q210		HT805501B0	HT805501B0	TRS.	KTC2874B	HVTKTC2874BT
Q211		HT805501B0	HT805501B0	TRS.	KTC2874B	HVTKTC2874BT
Q212		HT805501B0	HT805501B0	TRS.	KTC2874B	HVTKTC2874BT
Q213		HT805501B0	HT805501B0	TRS.	KTC2874B	HVTKTC2874BT
Q214		HT805501B0	HT805501B0	TRS.	KTC2874B	HVTKTC2874BT
Q215		BA10002000	BA10002000	TRS.	KRA104M	HVTKRA104MT
Q216		BA10002000	BA10002000	TRS.	KRA104M	HVTKRA104MT
Q217		BA10002000	BA10002000	TRS.	KRA104M	HVTKRA104MT
Q218		BA10002000	BA10002000	TRS.	KRA104M	HVTKRA104MT
Q219		BA10002000	BA10002000	TRS.	KRA104M	HVTKRA104MT
Q220		BA10002000	BA10002000	TRS.	KRA104M	HVTKRA104MT
Q221		BA20002000	BA20002000	TRS.	KRC104M	HVTKRC104MT
Q222		BA20002000	BA20002000	TRS.	KRC104M	HVTKRC104MT
Q223		BA20002000	BA20002000	TRS.	KRC104M	HVTKRC104MT
Q224		BA20002000	BA20002000	TRS.	KRC104M	HVTKRC104MT
Q225		BA20002000	BA20002000	TRS.	KRC104M	HVTKRC104MT
Q226		BA20002000	BA20002000	TRS.	KRC104M	HVTKRC104MT
Q233		HT805501B0	HT805501B0	TRS.	KTC2874B	HVTKTC2874BT
Q234		HT805501B0	HT805501B0	TRS.	KTC2874B	HVTKTC2874BT
Q235		HT805501B0	HT805501B0	TRS.	KTC2874B	HVTKTC2874BT
Q237		HT805501B0	HT805501B0	TRS.	KTC2874B	HVTKTC2874BT
Q238		HT805501B0	HT805501B0	TRS.	KTC2874B	HVTKTC2874BT
Q239		HT805501B0	HT805501B0	TRS.	KTC2874B	HVTKTC2874BT
Q240		BA10002000	BA10002000	TRS.	KRA104M	HVTKRA104MT
Q241		BA20002000	BA20002000	TRS.	KRC104M	HVTKRC104MT
R201		nsp	nsp	RES.	100Ω 1/6W J	CRD20TJ101T
R202		nsp	nsp	RES.	100Ω 1/6W J	CRD20TJ101T
R203		nsp	nsp	RES.	100Ω 1/6W J	CRD20TJ101T
R204		nsp	nsp	RES.	100Ω 1/6W J	CRD20TJ101T
R205		nsp	nsp	RES.	100Ω 1/6W J	CRD20TJ101T
R206		nsp	nsp	RES.	100Ω 1/6W J	CRD20TJ101T
R207		nsp	nsp	RES.	1kΩ 1/6W J	CRD20TJ102T
R208		nsp	nsp	RES.	1kΩ 1/6W J	CRD20TJ102T
R209		nsp	nsp	RES.	100Ω 1/6W J	CRD20TJ101T
R210		nsp	nsp	RES.	100Ω 1/6W J	CRD20TJ101T
R211		nsp	nsp	RES.	1kΩ 1/6W J	CRD20TJ102T
R212		nsp	nsp	RES.	1kΩ 1/6W J	CRD20TJ102T
R213		nsp	nsp	RES.	100Ω 1/6W J	CRD20TJ101T
R214		nsp	nsp	RES.	100Ω 1/6W J	CRD20TJ101T
R215		nsp	nsp	RES.	100Ω 1/6W J	CRD20TJ101T
R216		nsp	nsp	RES.	100Ω 1/6W J	CRD20TJ101T
R217		nsp	nsp	RES.	1kΩ 1/6W J	CRD20TJ102T
R218		nsp	nsp	RES.	1kΩ 1/6W J	CRD20TJ102T
R219		nsp	nsp	RES.	100Ω 1/6W J	CRD20TJ101T
R220		nsp	nsp	RES.	100Ω 1/6W J	CRD20TJ101T
R221		nsp	nsp	RES.	1kΩ 1/6W J	CRD20TJ102T
R222		nsp	nsp	RES.	1kΩ 1/6W J	CRD20TJ102T
R223		nsp	nsp	RES.	82kΩ 1/6W J	CRD20TJ823T
R224		nsp	nsp	RES.	82kΩ 1/6W J	CRD20TJ823T
R225		nsp	nsp	RES.	82kΩ 1/6W J	CRD20TJ823T
R226		nsp	nsp	RES.	82kΩ 1/6W J	CRD20TJ823T
R227		nsp	nsp	RES.	82kΩ 1/6W J	CRD20TJ823T
R228		nsp	nsp	RES.	82kΩ 1/6W J	CRD20TJ823T
R229		nsp	nsp	RES.	47kΩ 1/6W J	CRD20TJ473T
R230		nsp	nsp	RES.	47kΩ 1/6W J	CRD20TJ473T

NOTE : "nsp" PART IS LISTED FOR REFERENCE ONLY, MARANTZ WILL NOT SUPPLY THESE PARTS.

POS. NO	VERS. COLOR	PART NO. (FOR EUR)	PART NO. (MJI)	DESCRIPTION		
R231		nsp	nsp	RES.	82kΩ 1/6W J	CRD20TJ823T
R232		nsp	nsp	RES.	82kΩ 1/6W J	CRD20TJ823T
R233		nsp	nsp	RES.	47kΩ 1/6W J	CRD20TJ473T
R234		nsp	nsp	RES.	47kΩ 1/6W J	CRD20TJ473T
R235		nsp	nsp	RES.	82kΩ 1/6W J	CRD20TJ823T
R236		nsp	nsp	RES.	82kΩ 1/6W J	CRD20TJ823T
R237		nsp	nsp	RES.	82kΩ 1/6W J	CRD20TJ823T
R238		nsp	nsp	RES.	82kΩ 1/6W J	CRD20TJ823T
R239		nsp	nsp	RES.	47kΩ 1/6W J	CRD20TJ473T
R240		nsp	nsp	RES.	47kΩ 1/6W J	CRD20TJ473T
R241		nsp	nsp	RES.	82kΩ 1/6W J	CRD20TJ823T
R242		nsp	nsp	RES.	82kΩ 1/6W J	CRD20TJ823T
R243		nsp	nsp	RES.	47kΩ 1/6W J	CRD20TJ473T
R244		nsp	nsp	RES.	47kΩ 1/6W J	CRD20TJ473T
R245		nsp	nsp	RES.	100Ω 1/6W J	CRD20TJ101T
R246		nsp	nsp	RES.	100Ω 1/6W J	CRD20TJ101T
R247		nsp	nsp	RES.	100Ω 1/6W J	CRD20TJ101T
R248		nsp	nsp	RES.	100Ω 1/6W J	CRD20TJ101T
R249		nsp	nsp	RES.	100Ω 1/6W J	CRD20TJ101T
R250		nsp	nsp	RES.	100Ω 1/6W J	CRD20TJ101T
R251		nsp	nsp	RES.	100Ω 1/6W J	CRD20TJ101T
R252		nsp	nsp	RES.	47kΩ 1/6W J	CRD20TJ473T
R253		nsp	nsp	RES.	47kΩ 1/6W J	CRD20TJ473T
R254		nsp	nsp	RES.	47kΩ 1/6W J	CRD20TJ473T
R255		nsp	nsp	RES.	47kΩ 1/6W J	CRD20TJ473T
R256		nsp	nsp	RES.	47kΩ 1/6W J	CRD20TJ473T
R257		nsp	nsp	RES.	47kΩ 1/6W J	CRD20TJ473T
R258		nsp	nsp	RES.	47kΩ 1/6W J	CRD20TJ473T
R266		nsp	nsp	RES.	47kΩ 1/6W J	CRD20TJ473T
R267		nsp	nsp	RES.	47kΩ 1/6W J	CRD20TJ473T
R268		nsp	nsp	RES.	47kΩ 1/6W J	CRD20TJ473T
R269		nsp	nsp	RES.	47kΩ 1/6W J	CRD20TJ473T
R270		nsp	nsp	RES.	47kΩ 1/6W J	CRD20TJ473T
R271		nsp	nsp	RES.	47kΩ 1/6W J	CRD20TJ473T
R272		nsp	nsp	RES.	47kΩ 1/6W J	CRD20TJ473T
R273		nsp	nsp	RES.	100Ω 1/6W J	CRD20TJ101T
R274		nsp	nsp	RES.	100Ω 1/6W J	CRD20TJ101T
R275		nsp	nsp	RES.	220 KOHM 1/5W J	CRD20TJ224T
R276		nsp	nsp	RES.	220 KOHM 1/5W J	CRD20TJ224T
R277		nsp	nsp	RES.	220 KOHM 1/5W J	CRD20TJ224T
R278		nsp	nsp	RES.	220 KOHM 1/5W J	CRD20TJ224T
R279		nsp	nsp	RES.	47kΩ 1/6W J	CRD20TJ473T
R280		nsp	nsp	RES.	47kΩ 1/6W J	CRD20TJ473T
R281		nsp	nsp	RES.	47kΩ 1/6W J	CRD20TJ473T
R282		nsp	nsp	RES.	47kΩ 1/6W J	CRD20TJ473T
R283		nsp	nsp	RES.	100Ω 1/6W J	CRD20TJ101T
R284		nsp	nsp	RES.	47kΩ 1/6W J	CRD20TJ473T
R285		nsp	nsp	RES.	47kΩ 1/6W J	CRD20TJ473T
R286		nsp	nsp	RES.	47kΩ 1/6W J	CRD20TJ473T
R287		nsp	nsp	RES.	47kΩ 1/6W J	CRD20TJ473T
R288		nsp	nsp	RES.	47kΩ 1/6W J	CRD20TJ473T
R289		nsp	nsp	RES.	47kΩ 1/6W J	CRD20TJ473T
R290		nsp	nsp	RES.	47kΩ 1/6W J	CRD20TJ473T
R291		nsp	nsp	RES.	100Ω 1/6W J	CRD20TJ101T
R292		nsp	nsp	RES.	100Ω 1/6W J	CRD20TJ101T
R293		nsp	nsp	RES.	47kΩ 1/6W J	CRD20TJ473T
R294		nsp	nsp	RES.	47kΩ 1/6W J	CRD20TJ473T

NOTE : *nsp* PART IS LISTED FOR REFERENCE ONLY, MARANTZ WILL NOT SUPPLY THESE PARTS.

POS. NO	VERS. COLOR	PART NO. (FOR EUR)	PART NO. (MJ)	DESCRIPTION		
R295		nsp	nsp	RES.	47kΩ 1/6W J	CRD20TJ473T
R296		nsp	nsp	RES.	47kΩ 1/6W J	CRD20TJ473T
R297		nsp	nsp	RES.	47kΩ 1/6W J	CRD20TJ473T
R298		nsp	nsp	RES.	47kΩ 1/6W J	CRD20TJ473T
R299		nsp	nsp	RES.	47kΩ 1/6W J	CRD20TJ473T
R300		nsp	nsp	RES.	8.2kΩ 1/6W J	CRD20TJ822T
R301		nsp	nsp	RES.	8.2kΩ 1/6W J	CRD20TJ822T
R302		nsp	nsp	RES.	4.7kΩ 1/6W J	CRD20TJ472T
R303		nsp	nsp	RES.	4.7kΩ 1/6W J	CRD20TJ472T
R304		nsp	nsp	RES.	8.2kΩ 1/6W J	CRD20TJ822T
R305		nsp	nsp	RES.	8.2kΩ 1/6W J	CRD20TJ822T
R306		nsp	nsp	RES.	4.7kΩ 1/6W J	CRD20TJ472T
R314		nsp	nsp	RES.	15kΩ 1/6W J	CRD20TJ153T
R315		nsp	nsp	RES.	15kΩ 1/6W J	CRD20TJ153T
R316		nsp	nsp	RES.	4.7kΩ 1/6W J	CRD20TJ472T
R317		nsp	nsp	RES.	4.7kΩ 1/6W J	CRD20TJ472T
R318		nsp	nsp	RES.	15kΩ 1/6W J	CRD20TJ153T
R319		nsp	nsp	RES.	15kΩ 1/6W J	CRD20TJ153T
R320		nsp	nsp	RES.	4.7kΩ 1/6W J	CRD20TJ472T
R321		nsp	nsp	RES.	47kΩ 1/6W J	CRD20TJ473T
R322		nsp	nsp	RES.	47kΩ 1/6W J	CRD20TJ473T
R323		nsp	nsp	RES.	47kΩ 1/6W J	CRD20TJ473T
R324		nsp	nsp	RES.	47kΩ 1/6W J	CRD20TJ473T
R325		nsp	nsp	RES.	47kΩ 1/6W J	CRD20TJ473T
R326		nsp	nsp	RES.	47kΩ 1/6W J	CRD20TJ473T
R327		nsp	nsp	RES.	47kΩ 1/6W J	CRD20TJ473T
R328		nsp	nsp	RES.	220Ω 1/6W J	CRD20TJ221T
R329		nsp	nsp	RES.	220Ω 1/6W J	CRD20TJ221T
R330		nsp	nsp	RES.	220Ω 1/6W J	CRD20TJ221T
R331		nsp	nsp	RES.	220Ω 1/6W J	CRD20TJ221T
R332		nsp	nsp	RES.	220Ω 1/6W J	CRD20TJ221T
R333		nsp	nsp	RES.	220Ω 1/6W J	CRD20TJ221T
R334		nsp	nsp	RES.	220Ω 1/6W J	CRD20TJ221T
R336		nsp	nsp	RES.	1MΩ 1/6W J	CRD20TJ105T
R338		nsp	nsp	RES.	1MΩ 1/6W J	CRD20TJ105T
R340		nsp	nsp	RES.	1MΩ 1/6W J	CRD20TJ105T
R341		nsp	nsp	RES.	1MΩ 1/6W J	CRD20TJ105T
R342		nsp	nsp	RES.	10kΩ 1/6W J	CRD20TJ103T
R343		nsp	nsp	RES.	10kΩ 1/6W J	CRD20TJ103T
R344		nsp	nsp	RES.	10kΩ 1/6W J	CRD20TJ103T
R345		nsp	nsp	RES.	10kΩ 1/6W J	CRD20TJ103T
R346		nsp	nsp	RES.	10kΩ 1/6W J	CRD20TJ103T
R347		nsp	nsp	RES.	10kΩ 1/6W J	CRD20TJ103T
R348		nsp	nsp	RES.	10kΩ 1/6W J	CRD20TJ103T
R349		nsp	nsp	RES.	10kΩ 1/6W J	CRD20TJ103T
R350		nsp	nsp	RES.	10kΩ 1/6W J	CRD20TJ103T
R351		nsp	nsp	RES.	10kΩ 1/6W J	CRD20TJ103T
R352		nsp	nsp	RES.	10kΩ 1/6W J	CRD20TJ103T
R353		nsp	nsp	RES.	10kΩ 1/6W J	CRD20TJ103T
R354		nsp	nsp	RES.	10kΩ 1/6W J	CRD20TJ103T
R355		nsp	nsp	RES.	10kΩ 1/6W J	CRD20TJ103T
R356		nsp	nsp	RES.	220Ω 1/6W J	CRD20TJ221T
R357		nsp	nsp	RES.	220Ω 1/6W J	CRD20TJ221T
R358		nsp	nsp	RES.	220Ω 1/6W J	CRD20TJ221T
R359		nsp	nsp	RES.	220Ω 1/6W J	CRD20TJ221T
R360		nsp	nsp	RES.	220Ω 1/6W J	CRD20TJ221T
R361		nsp	nsp	RES.	220Ω 1/6W J	CRD20TJ221T

NOTE : "nsp" PART IS LISTED FOR REFERENCE ONLY, MARANTZ WILL NOT SUPPLY THESE PARTS.

POS. NO	VERS. COLOR	PART NO. (FOR EUR)	PART NO. (MJI)	DESCRIPTION		
R362		nsp	nsp	RES.	220Ω 1/6W J	CRD20TJ221T
R363		nsp	nsp	RES.	33Ω 1/6W J	CRD20TJ330T
R364		nsp	nsp	RES.	33Ω 1/6W J	CRD20TJ330T
R365		nsp	nsp	RES.	33Ω 1/6W J	CRD20TJ330T
R366		nsp	nsp	RES.	33Ω 1/6W J	CRD20TJ330T
R367		nsp	nsp	RES.	33Ω 1/6W J	CRD20TJ330T
R368		nsp	nsp	RES.	33Ω 1/6W J	CRD20TJ330T
R369		nsp	nsp	RES.	33Ω 1/6W J	CRD20TJ330T
R370		nsp	nsp	RES.	100Ω 1/6W J	CRD20TJ101T
R371		nsp	nsp	RES.	100Ω 1/6W J	CRD20TJ101T
R372		nsp	nsp	RES.	100Ω 1/6W J	CRD20TJ101T
R373		nsp	nsp	RES.	100Ω 1/6W J	CRD20TJ101T
R394 /F		nsp	nsp	RES.	100Ω 1/6W J	CRD20TJ101T
R395 /F		nsp	nsp	RES.	100Ω 1/6W J	CRD20TJ101T
R396 /F		nsp	nsp	RES.	82kΩ 1/6W J	CRD20TJ823T
R397 /F		nsp	nsp	RES.	82kΩ 1/6W J	CRD20TJ823T
R402		nsp	nsp	RES.	100Ω 1/6W J	CRD20TJ101T
R403		nsp	nsp	RES.	100kΩ 1/6W J	CRD20TJ104T
R404		nsp	nsp	RES.	100kΩ 1/6W J	CRD20TJ104T
R405		nsp	nsp	RES.	100kΩ 1/6W J	CRD20TJ104T
R406		nsp	nsp	RES.	100kΩ 1/6W J	CRD20TJ104T
R407		nsp	nsp	RES.	47kΩ 1/6W J	CRD20TJ473T
R408		nsp	nsp	RES.	47kΩ 1/6W J	CRD20TJ473T
R409		nsp	nsp	RES.	47kΩ 1/6W J	CRD20TJ473T
R410		nsp	nsp	RES.	4.7kΩ 1/6W J	CRD20TJ472T
R411		nsp	nsp	RES.	33kΩ 1/6W J	CRD20TJ333T
R413		nsp	nsp	RES.	47kΩ 1/6W J	CRD20TJ473T
R414		nsp	nsp	RES.	220Ω 1/6W J	CRD20TJ221T
R415		nsp	nsp	RES.	1MΩ 1/6W J	CRD20TJ105T
R416		nsp	nsp	RES.	10kΩ 1/6W J	CRD20TJ103T
R417		nsp	nsp	RES.	10kΩ 1/6W J	CRD20TJ103T
R418		nsp	nsp	RES.	220Ω 1/6W J	CRD20TJ221T
R419		nsp	nsp	RES.	33Ω 1/6W J	CRD20TJ330T
R420		nsp	nsp	RES.	47kΩ 1/6W J	CRD20TJ473T
R421		nsp	nsp	RES.	4.7kΩ 1/6W J	CRD20TJ472T
R423		nsp	nsp	RES.	4.7kΩ 1/6W J	CRD20TJ472T
R424		nsp	nsp	RES.	220Ω 1/6W J	CRD20TJ221T
R425		nsp	nsp	RES.	47kΩ 1/6W J	CRD20TJ473T
R426		nsp	nsp	RES.	47kΩ 1/6W J	CRD20TJ473T
R427		nsp	nsp	RES.	220Ω 1/6W J	CRD20TJ221T
R428		nsp	nsp	RES.	4.7kΩ 1/6W J	CRD20TJ472T
R429		nsp	nsp	RES.	4.7kΩ 1/6W J	CRD20TJ472T
R431		nsp	nsp	RES.	47kΩ 1/6W J	CRD20TJ473T
R432		nsp	nsp	RES.	1MΩ 1/6W J	CRD20TJ105T
R433		nsp	nsp	RES.	10kΩ 1/6W J	CRD20TJ103T
R434		nsp	nsp	RES.	10kΩ 1/6W J	CRD20TJ103T
R435		nsp	nsp	RES.	220Ω 1/6W J	CRD20TJ221T
R436		nsp	nsp	RES.	10kΩ 1/6W J	CRD20TJ103T
R437		nsp	nsp	RES.	10kΩ 1/6W J	CRD20TJ103T
R438		nsp	nsp	RES.	220Ω 1/6W J	CRD20TJ221T
R439		nsp	nsp	RES.	33Ω 1/6W J	CRD20TJ330T
R440		nsp	nsp	RES.	33Ω 1/6W J	CRD20TJ330T
R441		nsp	nsp	RES.	100Ω 1/6W J	CRD20TJ101T
R442		nsp	nsp	RES.	47kΩ 1/6W J	CRD20TJ473T
R444		nsp	nsp	RES.	47kΩ 1/6W J	CRD20TJ473T
R445		nsp	nsp	RES.	47kΩ 1/6W J	CRD20TJ473T
R446		nsp	nsp	RES.	100Ω 1/6W J	CRD20TJ101T

NOTE : *nsp* PART IS LISTED FOR REFERENCE ONLY, MARANTZ WILL NOT SUPPLY THESE PARTS.

POS. NO	VERS. COLOR	PART NO. (FOR EUR)	PART NO. (MJ)	DESCRIPTION		
R447		nsp	nsp	RES.	100Ω 1/6W J	CRD20TJ101T
R448		nsp	nsp	RES.	47kΩ 1/6W J	CRD20TJ473T
R449		nsp	nsp	RES.	47kΩ 1/6W J	CRD20TJ473T
				POWER PCB (CUP11659-1), VIDEO PCB (CUP11659-2)		
BN21		nsp	nsp	CONN. CORD		CWB1C906270EN
BN65		nsp	nsp	CONN. CORD		CWB3F006100UZ
BN73		nsp	nsp	CONN. CORD		CWB3F006100UZ
BN81		nsp	nsp	CONN. CORD		CWB1B906150EN
BN82		nsp	nsp	CONN. CORD		CWZSR7400BN82
C602		*OF100370R	*OF100370R	FILM CAP	0.022μF 50V J	HCQ1H223JZT
C603		*OF100370R	*OF100370R	FILM CAP	0.022μF 50V J	HCQ1H223JZT
C604		*OF100370R	*OF100370R	FILM CAP	0.022μF 50V J	HCQ1H223JZT
C605		*OF100370R	*OF100370R	FILM CAP	0.022μF 50V J	HCQ1H223JZT
C606		*OF100370R	*OF100370R	FILM CAP	0.022μF 50V J	HCQ1H223JZT
C611		nsp	nsp	CER. CAP.	1000pF 50V KB	CCKT1H102KB
C612		nsp	nsp	CER. CAP.	1000pF 50V KB	CCKT1H102KB
C613		nsp	nsp	CER. CAP.	1000pF 50V KB	CCKT1H102KB
C614		nsp	nsp	CER. CAP.	1000pF 50V KB	CCKT1H102KB
C615		nsp	nsp	CER. CAP.	1000pF 50V KB	CCKT1H102KB
C622		*OF100370R	*OF100370R	FILM CAP	0.022μF 50V J	HCQ1H223JZT
C623		*OF100370R	*OF100370R	FILM CAP	0.022μF 50V J	HCQ1H223JZT
C624		*OF100370R	*OF100370R	FILM CAP	0.022μF 50V J	HCQ1H223JZT
C625		*OF100370R	*OF100370R	FILM CAP	0.022μF 50V J	HCQ1H223JZT
C626		*OF100370R	*OF100370R	FILM CAP	0.022μF 50V J	HCQ1H223JZT
▲ C633		EB10907170	EB10907170	ELECT. CAP.	DL71VN 18000(M)	HCET71VDL183N
▲ C634		EB10907170	EB10907170	ELECT. CAP.	DL71VN 18000(M)	HCET71VDL183N
C638		nsp	OA47601640	ELECT. CAP.	47μF 16V	HCEA1CH470T
C639		nsp	nsp	CER. CAP.	1000pF 50V KB	CCKT1H102KB
C640		EA33803510	EA33803510	ELECT. CAP.	3300μF 35V	HCEA1VH332E
C641		nsp	OA22803520	ELECT. CAP.	2200μF 35V	HCEA1VH222E
C642		nsp	nsp	CER. CAP.	0.01μF 50V ZF	CCKT1H103ZF
C644		nsp	nsp	CER. CAP.	0.01μF 50V ZF	CCKT1H103ZF
C645		nsp	nsp	CER. CAP.	0.01μF 50V ZF	CCKT1H103ZF
C646		nsp	nsp	CER. CAP.	0.01μF 50V ZF	CCKT1H103ZF
C647		nsp	nsp	CER. CAP.	0.01μF 50V ZF	CCKT1H103ZF
C648		nsp	OA10701620	ELECT. CAP.	100μF 16V	HCEA1CH101T
C649		nsp	OA10701620	ELECT. CAP.	100μF 16V	HCEA1CH101T
C651		nsp	OA68801620	ELECT. CAP.	6800μF 16V	HCEA1CH682E
C652		EA10901670	EA10901670	ELECT. CAP.	10000μF 16V	HCEA1CH103E
C653		nsp	OA10701620	ELECT. CAP.	100μF 16V	HCEA1CH101T
C654		nsp	OA10701620	ELECT. CAP.	100μF 16V	HCEA1CH101T
C655		nsp	nsp	CER. CAP.	50V 0.1μF	CCKT1H104ZF
C656		nsp	nsp	CER. CAP.	50V 0.1μF	CCKT1H104ZF
C657		nsp	nsp	CER. CAP.	50V 0.1μF	CCKT1H104ZF
C658		nsp	nsp	CER. CAP.	50V 0.1μF	CCKT1H104ZF
C659		nsp	OA10710020	ELECT. CAP.	100μF 100V	HCEA2AH101E
C661		nsp	nsp	CER. CAP.	50V 0.1μF	CCKT1H104ZF
C662		nsp	nsp	CER. CAP.	50V 0.1μF	CCKT1H104ZF
C663		nsp	nsp	CER. CAP.	50V 0.1μF	CCKT1H104ZF
C664		nsp	nsp	CER. CAP.	50V 0.1μF	CCKT1H104ZF
C665		nsp	nsp	CER. CAP.	50V 0.1μF	CCKT1H104ZF
C702		nsp	OA10605020	ELECT. CAP.	10μF 50V	HCEA1HH100T
C704		nsp	OA10605020	ELECT. CAP.	10μF 50V	HCEA1HH100T
C706		nsp	OA10605020	ELECT. CAP.	10μF 50V	HCEA1HH100T
C707		nsp	nsp	CER. CAP.	47pF 50V JC	CCCT1H470JC

NOTE : "nsp" PART IS LISTED FOR REFERENCE ONLY, MARANTZ WILL NOT SUPPLY THESE PARTS.

POS. NO	VERS. COLOR	PART NO. (FOR EUR)	PART NO. (MJI)	DESCRIPTION		
C708		nsp	OA47701020	ELECT. CAP.	470µF 10V	HCEA1AH471T
C710		nsp	OA10605020	ELECT. CAP.	10µF 50V	HCEA1HH100T
C711		nsp	nsp	CER. CAP.	47pF 50V JC	CCCT1H470JC
C712		nsp	OA47701020	ELECT. CAP.	470µF 10V	HCEA1AH471T
C713		nsp	nsp	CER. CAP.	68pF 50V JC	CCCT1H680JC
C714		nsp	OA47701020	ELECT. CAP.	470µF 10V	HCEA1AH471T
C715		nsp	OA10605020	ELECT. CAP.	10µF 50V	HCEA1HH100T
C716		nsp	OA10605020	ELECT. CAP.	10µF 50V	HCEA1HH100T
C717		nsp	OA10605020	ELECT. CAP.	10µF 50V	HCEA1HH100T
C719		nsp	OA10605020	ELECT. CAP.	10µF 50V	HCEA1HH100T
C720		nsp	OA10605020	ELECT. CAP.	10µF 50V	HCEA1HH100T
C722		nsp	OA10605020	ELECT. CAP.	10µF 50V	HCEA1HH100T
C723		nsp	OA10605020	ELECT. CAP.	10µF 50V	HCEA1HH100T
C725		nsp	OA10605020	ELECT. CAP.	10µF 50V	HCEA1HH100T
C726		nsp	OA10605020	ELECT. CAP.	10µF 50V	HCEA1HH100T
C727		nsp	nsp	CER. CAP.	47pF 50V JC	CCCT1H470JC
C728		nsp	OA47701020	ELECT. CAP.	470µF 10V	HCEA1AH471T
C729		nsp	nsp	CER. CAP.	47pF 50V JC	CCCT1H470JC
C730		nsp	OA10605020	ELECT. CAP.	10µF 50V	HCEA1HH100T
C732		nsp	OA10605020	ELECT. CAP.	10µF 50V	HCEA1HH100T
C733		nsp	OA10605020	ELECT. CAP.	10µF 50V	HCEA1HH100T
C734		nsp	nsp	CER. CAP.	47pF 50V JC	CCCT1H470JC
C735		nsp	OA47701020	ELECT. CAP.	470µF 10V	HCEA1AH471T
C736		nsp	nsp	CER. CAP.	47pF 50V JC	CCCT1H470JC
C737		nsp	OA10605020	ELECT. CAP.	10µF 50V	HCEA1HH100T
C738		nsp	nsp	CER. CAP.	68pF 50V JC	CCCT1H680JC
C739		nsp	OA47701020	ELECT. CAP.	470µF 10V	HCEA1AH471T
C740		nsp	nsp	CER. CAP.	68pF 50V JC	CCCT1H680JC
C741		nsp	OA10605020	ELECT. CAP.	10µF 50V	HCEA1HH100T
C742		nsp	OA10605020	ELECT. CAP.	10µF 50V	HCEA1HH100T
C743		nsp	nsp	JUMPER	SN95/PB5 , 0.6	C3A206
C744		nsp	OA22505020	ELECT. CAP.	2.2µF 50V	HCEA1HH2R2T
C745		nsp	OA10605020	ELECT. CAP.	10µF 50V	HCEA1HH100T
C746		nsp	OA10605020	ELECT. CAP.	10µF 50V	HCEA1HH100T
C747		nsp	OA10605020	ELECT. CAP.	10µF 50V	HCEA1HH100T
C748		nsp	nsp	CER. CAP.	0.01µF 50V ZF	CCKT1H103ZF
C749		nsp	OA10701620	ELECT. CAP.	100µF 16V	HCEA1CH101T
C751		nsp	OA47505020	ELECT. CAP.	4.7µF 50V	HCEA1HH4R7T
C752		nsp	OA10605020	ELECT. CAP.	10µF 50V	HCEA1HH100T
C753		nsp	OA10701620	ELECT. CAP.	100µF 16V	HCEA1CH101T
C754		nsp	nsp	CER. CAP.	0.01µF 50V ZF	CCKT1H103ZF
C755		nsp	nsp	CER. CAP.	47pF 50V JC	CCCT1H470JC
C756		nsp	nsp	CER. CAP.	0.01µF 50V ZF	CCKT1H103ZF
C757		nsp	OA10701620	ELECT. CAP.	100µF 16V	HCEA1CH101T
C758		nsp	OA10701620	ELECT. CAP.	100µF 16V	HCEA1CH101T
C759		nsp	nsp	CER. CAP.	0.01µF 50V ZF	CCKT1H103ZF
C760		nsp	nsp	CER. CAP.	47pF 50V JC	CCCT1H470JC
C761		nsp	nsp	CER. CAP.	0.01µF 50V ZF	CCKT1H103ZF
C762		nsp	OA10701620	ELECT. CAP.	100µF 16V	HCEA1CH101T
C763		nsp	OA10701620	ELECT. CAP.	100µF 16V	HCEA1CH101T
C764		nsp	nsp	CER. CAP.	0.01µF 50V ZF	CCKT1H103ZF
C765		nsp	nsp	CER. CAP.	47pF 50V JC	CCCT1H470JC
C766		nsp	nsp	CER. CAP.	0.01µF 50V ZF	CCKT1H103ZF
C767		nsp	OA10701620	ELECT. CAP.	100µF 16V	HCEA1CH101T
C768		nsp	nsp	CER. CAP.	1200pF 50V KB	CCKT1H122KB
C769		nsp	OA10505020	ELECT. CAP.	1µF 50V	HCEA1HH1R0T
C770		nsp	nsp	CER. CAP.	0.01µF 50V ZF	CCKT1H103ZF

NOTE : *nsp* PART IS LISTED FOR REFERENCE ONLY, MARANTZ WILL NOT SUPPLY THESE PARTS.

POS. NO	VERS. COLOR	PART NO. (FOR EUR)	PART NO. (MJ)	DESCRIPTION		
C771		nsp	OA10701620	ELECT. CAP.	100µF 16V	HCEA1CH101T
C773		nsp	nsp	CER. CAP.	24pF 50V JC	CCCT1H240JC
C774		nsp	nsp	CER. CAP.	22pF 50V JC	CCCT1H220JC
C775		nsp	OA10505020	ELECT. CAP.	1µF 50V	HCEA1HH1R0T
C776		nsp	nsp	CER. CAP.	0.01µF 50V ZF	CCKT1H103ZF
C777		nsp	nsp	CER. CAP.	30pF 50V JC	CCCT1H300JC
C778	F/L/U	nsp	nsp	CER. CAP.	30pF 50V JC	CCCT1H300JC
C778	K/N/S	nsp	nsp	CER. CAP.	27pF 50V JC	CCCT1H270JC
C779		nsp	OA10605020	ELECT. CAP.	10µF 50V	HCEA1HH100T
C780		nsp	nsp	CER. CAP.	47pF 50V JC	CCCT1H470JC
C781		nsp	nsp	CER. CAP.	1000pF 50V KB	CCKT1H102KB
C782		nsp	nsp	CER. CAP.	220pF 50V KB	CCKT1H221KB
C783		nsp	OA10605020	ELECT. CAP.	10µF 50V	HCEA1HH100T
C785		nsp	nsp	CER. CAP.	0.01µF 50V ZF	CCKT1H103ZF
C786		nsp	nsp	CER. CAP.	0.01µF 50V ZF	CCKT1H103ZF
C787		nsp	OA10701620	ELECT. CAP.	100µF 16V	HCEA1CH101T
C788		nsp	OA10605020	ELECT. CAP.	10µF 50V	HCEA1HH100T
C789		nsp	OA10605020	ELECT. CAP.	10µF 50V	HCEA1HH100T
C790		nsp	nsp	CER. CAP.	0.01µF 50V ZF	CCKT1H103ZF
C791		nsp	nsp	CER. CAP.	0.01µF 50V ZF	CCKT1H103ZF
C792		nsp	OA10701620	ELECT. CAP.	100µF 16V	HCEA1CH101T
C793		nsp	nsp	CER. CAP.	0.022µF 50V ZF	CCKT1H223ZF
C794		nsp	nsp	CER. CAP.	47pF 50V JC	CCCT1H470JC
C795		nsp	OA10701620	ELECT. CAP.	100µF 16V	HCEA1CH101T
C796		nsp	nsp	CER. CAP.	0.01µF 50V ZF	CCKT1H103ZF
C797		nsp	OA10605020	ELECT. CAP.	10µF 50V	HCEA1HH100T
C798		nsp	nsp	CER. CAP.	0.01µF 50V ZF	CCKT1H103ZF
C799		nsp	nsp	CER. CAP.	0.01µF 50V ZF	CCKT1H103ZF
C800		nsp	OA10605020	ELECT. CAP.	10µF 50V	HCEA1HH100T
C802		nsp	OA10605020	ELECT. CAP.	10µF 50V	HCEA1HH100T
C803		nsp	nsp	CER. CAP.	0.01µF 50V ZF	CCKT1H103ZF
C804		nsp	nsp	CER. CAP.	0.01µF 50V ZF	CCKT1H103ZF
C805		nsp	OA10701620	ELECT. CAP.	100µF 16V	HCEA1CH101T
C806		nsp	nsp	CER. CAP.	0.01µF 50V ZF	CCKT1H103ZF
C807		nsp	nsp	CER. CAP.	1000pF 50V KB	CCKT1H102KB
C808		nsp	nsp	CER. CAP.	50V 0.1µF	CCKT1H104ZF
C811		nsp	OA10701620	ELECT. CAP.	100µF 16V	HCEA1CH101T
C812		nsp	nsp	CER. CAP.	0.01µF 50V ZF	CCKT1H103ZF
C813		nsp	nsp	CER. CAP.	0.01µF 50V ZF	CCKT1H103ZF
C814		nsp	OA10605020	ELECT. CAP.	10µF 50V	HCEA1HH100T
C815		nsp	nsp	CER. CAP.	47pF 50V JC	CCCT1H470JC
C817		nsp	OA10701620	ELECT. CAP.	100µF 16V	HCEA1CH101T
C818		nsp	nsp	CER. CAP.	0.01µF 50V ZF	CCKT1H103ZF
C819		nsp	nsp	CER. CAP.	0.01µF 50V ZF	CCKT1H103ZF
C820		nsp	OA10701620	ELECT. CAP.	100µF 16V	HCEA1CH101T
C821		nsp	nsp	CER. CAP.	68pF 50V JC	CCCT1H680JC
C822		nsp	OA47701020	ELECT. CAP.	470µF 10V	HCEA1AH471T
C823		nsp	OA10605020	ELECT. CAP.	10µF 50V	HCEA1HH100T
C824		nsp	OA10605020	ELECT. CAP.	10µF 50V	HCEA1HH100T
C825		nsp	OA10605020	ELECT. CAP.	10µF 50V	HCEA1HH100T
C827		nsp	nsp	CER. CAP.	1000pF 50V KB	CCKT1H102KB
C828		nsp	nsp	CER. CAP.	0.01µF 50V ZF	CCKT1H103ZF
C829		nsp	nsp	CER. CAP.	47pF 50V JC	CCCT1H470JC
C830		nsp	nsp	CER. CAP.	47pF 50V JC	CCCT1H470JC
C831		nsp	OA10605020	ELECT. CAP.	10µF 50V	HCEA1HH100T
C833		nsp	OA10605020	ELECT. CAP.	10µF 50V	HCEA1HH100T
C834		nsp	OA10605020	ELECT. CAP.	10µF 50V	HCEA1HH100T

NOTE : "nsp" PART IS LISTED FOR REFERENCE ONLY, MARANTZ WILL NOT SUPPLY THESE PARTS.

POS. NO	VERS. COLOR	PART NO. (FOR EUR)	PART NO. (MJI)	DESCRIPTION		
CN12		nsp	nsp	JACK	MOLEX53014-0510	KJP05GA19ZM
CN17		nsp	nsp	JACK	MOLEX53014-0510	KJP05GA19ZM
CN37		nsp	nsp	JACK	GF102-11S-TS	KJP11GA117ZG
CN41		nsp	nsp	JACK	MOLEX53014-0610	KJP06GA19ZM
CN61		nsp	nsp	JACK	MOLEX53014-0810	KJP08GA19ZM
CN62		nsp	nsp	JACK	MOLEX53014-0710	KJP07GA19ZM
CN63		nsp	nsp	JACK	MOLEX53014-0510	KJP05GA19ZM
CN64		nsp	nsp	JACK	MOLEX53014-0510	KJP05GA19ZM
CN65		nsp	nsp	JACK	GF102-13S-TS	KJP13GA117ZG
CN66		nsp	nsp	JACK	MOLEX 5267-04A	KJP04GA01ZM
CN67		nsp	nsp	JACK	A3963WV2-5P	CJP05GA148ZW
CN68		nsp	nsp	JACK	A3963WV2-5P	CJP05GA148ZW
CN69		nsp	nsp	JACK		KJP05GA98ZM
CN81		nsp	nsp	JACK	MOLEX53014-0610	KJP06GA19ZM
D601		nsp	*HD201750R	DIODE	TW 1N4003	KVD1N4003SRT
D602		nsp	*HD201750R	DIODE	TW 1N4003	KVD1N4003SRT
D603		nsp	*HD201750R	DIODE	TW 1N4003	KVD1N4003SRT
D604		nsp	*HD201750R	DIODE	TW 1N4003	KVD1N4003SRT
D605		nsp	*HD201750R	DIODE	TW 1N4003	KVD1N4003SRT
▲ D606		*HD201750R	*HD201750R	DIODE	TW 1N4003	KVD1N4003SRT
▲ D607		*HD201750R	*HD201750R	DIODE	TW 1N4003	KVD1N4003SRT
▲ D608		*HD201750R	*HD201750R	DIODE	TW 1N4003	KVD1N4003SRT
▲ D609		*HD201750R	*HD201750R	DIODE	TW 1N4003	KVD1N4003SRT
▲ D610		*HD201750R	*HD201750R	DIODE	TW 1N4003	KVD1N4003SRT
▲ D611		*HD201750R	*HD201750R	DIODE	TW 1N4003	KVD1N4003SRT
▲ D612		*HD201750R	*HD201750R	DIODE	TW 1N4003	KVD1N4003SRT
▲ D613		*HD201750R	*HD201750R	DIODE	TW 1N4003	KVD1N4003SRT
D614		nsp	*HD201750R	DIODE	TW 1N4003	KVD1N4003SRT
D615		*HD302150R	*HD302150R	ZENER DIODE	6.8V 1/2W	HVDMTZJ6.8BT
D616		*HD302190R	*HD302190R	ZENER DIODE	30V 1/2W	HVDMTZJ30BT
D617		nsp	nsp	JUMPER	SN95/PB5 , 0.6	C3A206
D618		nsp	*HD201750R	DIODE	TW 1N4003	KVD1N4003SRT
D619		nsp	*HD201750R	DIODE	TW 1N4003	KVD1N4003SRT
D620		nsp	*HD201750R	DIODE	TW 1N4003	KVD1N4003SRT
D621		nsp	*HD201750R	DIODE	TW 1N4003	KVD1N4003SRT
D623		nsp	*HD201750R	DIODE	TW 1N4003	KVD1N4003SRT
▲ D631		*HE200340R	*HE200340R	DIODE	GBJ804	HVDGBJ804
D701		nsp	HD20015210	DIODE	1SS133T-77	HVD1SS133MT
D702		nsp	HD20015210	DIODE	1SS133T-77	HVD1SS133MT
D704		nsp	HD20015210	DIODE	1SS133T-77	HVD1SS133MT
D705		nsp	*HD201750R	DIODE	TW 1N4003	KVD1N4003SRT
D706		nsp	HD20015210	DIODE	1SS133T-77	HVD1SS133MT
D707		nsp	HD20015210	DIODE	1SS133T-77	HVD1SS133MT
ET01		nsp	nsp	TERMINAL		CNE75
IC09		*HC300560R	*HC300560R	IC REG		HVIMC7905C
▲ IC61		*HC300500R	*HC300500R	IC REG	KA7805-ABTU	HVIMC7805C
▲ IC62		*HC300500R	*HC300500R	IC REG	KA7805-ABTU	HVIMC7805C
▲ IC63		*HC300520R	*HC300520R	IC REG	KA7812-ABTU	HVIMC7812C
▲ IC64		HC3991209F	HC3991209F	IC REG		HVINJM7912FA
IC71		HC10227090	HC10227090	IC	NJM2595D	HVINJM2595D
IC72		HC10227090	HC10227090	IC	NJM2595D	HVINJM2595D
IC73		HC10227090	HC10227090	IC	NJM2595D	HVINJM2595D
IC74		*HC108400R	*HC108400R	IC	NJM2535D	HVINJM2535D
IC75		HC10185090	HC10185090	IC	NJM2264D	HVINJM2264D
IC76		HC10119090	HC10119090	IC	NJM2244D	HVINJM2244D
IC77		HC10119090	HC10119090	IC	NJM2244D	HVINJM2244D
IC78		HC10377030	HC10377030	IC	LC74781-9013	HVILC74781-9013

NOTE : *nsp* PART IS LISTED FOR REFERENCE ONLY, MARANTZ WILL NOT SUPPLY THESE PARTS.

POS. NO	VERS. COLOR	PART NO. (FOR EUR)	PART NO. (MJ)	DESCRIPTION		
IC79		*HC108420R	*HC108420R	IC	TC74HC4094AP	HVITC74HC4094AP
IC80		*HC108420R	*HC108420R	IC	TC74HC4094AP	HVITC74HC4094AP
IC81		HC10227090	HC10227090	IC	NJM2595D	HVINJM2595D
IC82		HC10119090	HC10119090	IC	NJM2244D	HVINJM2244D
J611						
J		nsp	nsp	JUMPER	SN95/PB5 , 0.6	C3A206
J837						
JC71		nsp	nsp	JACK	25053WS-06A02	CJP06TT122ZP
JC72		nsp	nsp	JACK	25053WS-06A02	CJP06TT122ZP
JC73		nsp	nsp	JACK	25053WS-06A02	CJP06TT122ZP
JC74		nsp	nsp	JACK	GF102-11S-TS	KJP11GA117ZG
JK61		*YT003270R	*YT003270R	TERMINAL		CJJ5Q007Z
JK62		*YT003280R	*YT003280R	TERMINAL		CJJ5P011Z
JK63		*YT003680R	*YT003680R	TERMINAL		CJJ5N005Z
JK71		*YT002940R	*YT002940R	TERMINAL		CJJ4S010Z
JK72		*YT002940R	*YT002940R	TERMINAL		CJJ4S010Z
JK73		*YT002950R	*YT002950R	TERMINAL		CJJ4N043Z
JK74		*YT003260R	*YT003260R	TERMINAL		CJJ9S001Z
JK75		*YT003250R	*YT003250R	TERMINAL		CJJ9N001Z
JK76		*YT003250R	*YT003250R	TERMINAL		CJJ9N001Z
L701		nsp	nsp	COIL	33µH	HLQ02C330JT
L702		nsp	nsp	COIL	33µH	HLQ02C330JT
Q601		*HT600040R	*HT600040R	TRS.	KTA1267YT	HVTKTA1267YT
Q602		*HT600040R	*HT600040R	TRS.	KTA1267YT	HVTKTA1267YT
Q603		*HT600040R	*HT600040R	TRS.	KTA1267YT	HVTKTA1267YT
Q604		*HT600040R	*HT600040R	TRS.	KTA1267YT	HVTKTA1267YT
Q606		*HT600040R	*HT600040R	TRS.	KTA1267YT	HVTKTA1267YT
Q607		BA20001000	BA20001000	TRS.	KRC102M	HVTKRC102MT
Q608		BA20001000	BA20001000	TRS.	KRC102M	HVTKRC102MT
Q609		BA20001000	BA20001000	TRS.	KRC102M	HVTKRC102MT
Q610		BA20001000	BA20001000	TRS.	KRC102M	HVTKRC102MT
Q611		BA20001000	BA20001000	TRS.	KRC102M	HVTKRC102MT
Q612		*HT600040R	*HT600040R	TRS.	KTA1267YT	HVTKTA1267YT
Q613		*HT800050R	*HT800050R	TRS.	KTC3198YT	HVTKTC3198YT
Q614		*HT800050R	*HT800050R	TRS.	KTC3198YT	HVTKTC3198YT
Q615		*HT600040R	*HT600040R	TRS.	KTA1267YT	HVTKTA1267YT
Q616		BA20001000	BA20001000	TRS.	KRC102M	HVTKRC102MT
Q701		*HT600040R	*HT600040R	TRS.	KTA1267YT	HVTKTA1267YT
Q702		BA10001000	BA10001000	TRS.	KRA102M	HVTKRA102MT
Q703		HT30001000	HT30001000	TRS.	KTC3199YT	HVTKTC3199YT
Q704		HT30001000	HT30001000	TRS.	KTC3199YT	HVTKTC3199YT
Q705	/K/N/S	BA20004000	BA20004000	TRS.	KRC111M	HVTKRC111MT
Q706	/K/N/S	BA20004000	BA20004000	TRS.	KRC111M	HVTKRC111MT
Q707	/K/N/S	BA10001000	BA10001000	TRS.	KRA102M	HVTKRA102MT
Q708		HT30001000	HT30001000	TRS.	KTC3199YT	HVTKTC3199YT
Q710		BA20001000	BA20001000	TRS.	KRC102M	HVTKRC102MT
Q711		HT30001000	HT30001000	TRS.	KTC3199YT	HVTKTC3199YT
Q712		HT30001000	HT30001000	TRS.	KTC3199YT	HVTKTC3199YT
Q713		BA10001000	BA10001000	TRS.	KRA102M	HVTKRA102MT
R601		nsp	nsp	RES.	220Ω 1/4W J	CRD25TJ221T
R602		nsp	nsp	RES.	330Ω 1/4W J	CRD25TJ331T
R603		nsp	nsp	RES.	220Ω 1/4W J	CRD25TJ221T
R604		nsp	nsp	RES.	330Ω 1/4W J	CRD25TJ331T
R605		nsp	nsp	RES.	220Ω 1/4W J	CRD25TJ221T
R606		nsp	nsp	RES.	330Ω 1/4W J	CRD25TJ331T
R607		nsp	nsp	RES.	220Ω 1/4W J	CRD25TJ221T
R608		nsp	nsp	RES.	330Ω 1/4W J	CRD25TJ331T

NOTE : "nsp" PART IS LISTED FOR REFERENCE ONLY, MARANTZ WILL NOT SUPPLY THESE PARTS.

POS. NO	VERS. COLOR	PART NO. (FOR EUR)	PART NO. (MJI)	DESCRIPTION		
R609		nsp	nsp	RES.	220Ω 1/4W J	CRD25TJ221T
R610		nsp	nsp	RES.	330Ω 1/4W J	CRD25TJ331T
R611		nsp	nsp	RES.	10kΩ 1/6W J	CRD20TJ103T
R612		nsp	nsp	RES.	10kΩ 1/6W J	CRD20TJ103T
R613		nsp	nsp	RES.	10kΩ 1/6W J	CRD20TJ103T
R614		nsp	nsp	RES.	10kΩ 1/6W J	CRD20TJ103T
R615		nsp	nsp	RES.	10kΩ 1/6W J	CRD20TJ103T
R616		nsp	nsp	RES.	10kΩ 1/6W J	CRD20TJ103T
R617		nsp	nsp	RES.	10kΩ 1/6W J	CRD20TJ103T
R618		nsp	nsp	RES.	10kΩ 1/6W J	CRD20TJ103T
R619		nsp	nsp	RES.	10kΩ 1/6W J	CRD20TJ103T
R620		nsp	nsp	RES.	10kΩ 1/6W J	CRD20TJ103T
R622		nsp	nsp	RES.	10Ω 1W J	KRG1SANJ100RT
R623		nsp	nsp	RES.	10Ω 1W J	KRG1SANJ100RT
R624		nsp	nsp	RES.	10Ω 1W J	KRG1SANJ100RT
R625		nsp	nsp	RES.	10Ω 1W J	KRG1SANJ100RT
R626		nsp	nsp	RES.	10Ω 1W J	KRG1SANJ100RT
R627		nsp	nsp	RES.	330Ω	CRG1ANJ331H
R628		nsp	nsp	RES.	330Ω	CRG1ANJ331H
R631		nsp	nsp	RES.	150Ω 1/4W J	CRD25TJ151T
R632		nsp	nsp	RES.	150Ω 1/4W J	CRD25TJ151T
R633		nsp	nsp	RES.	15kΩ 1/6W J	CRD20TJ153T
R634		nsp	nsp	RES.	15kΩ 1/6W J	CRD20TJ153T
R635		nsp	nsp	RES.	15kΩ 1/6W J	CRD20TJ153T
R636		nsp	nsp	RES.	15kΩ 1/6W J	CRD20TJ153T
R637		nsp	nsp	RES.	10kΩ 1/6W J	CRD20TJ103T
R638		nsp	nsp	RES.	33kΩ 1/6W J	CRD20TJ333T
R639		nsp	nsp	RES.	100kΩ 1/6W J	CRD20TJ104T
R640		nsp	nsp	RES.	1Ω	CRG1ANJ1R0H
R641		nsp	nsp	RES.	1Ω	CRG1ANJ1R0H
R642		nsp	nsp	RES.	10kΩ 1/6W J	CRD20TJ103T
R643		nsp	nsp	RES.	10kΩ 1/6W J	CRD20TJ103T
R644		nsp	nsp	RES.	22kΩ 1/6W J	CRD20TJ223T
R645		nsp	nsp	RES.	22kΩ 1/6W J	CRD20TJ223T
R646		nsp	nsp	RES.	10kΩ 1/6W J	CRD20TJ103T
R647		nsp	nsp	RES.	1Ω 1/4W J	CRD25TJ1R0T
R648		nsp	nsp	RES.	2.2kΩ 1W J	KRG1SANJ222RT
R649		nsp	nsp	RES.	1.5kΩ 1W J	KRG1SANJ152RT
R650		nsp	nsp	RES.	100Ω 1/4W J	CRD25TJ101T
R651		nsp	nsp	RES.	100Ω 1/4W J	CRD25TJ101T
R652		nsp	nsp	JUMPER	SN95/PB5 , 0,6	C3A206
 R653		*NH000150R	*NH000150R	FUSE RES.	0.15Ω 1W J	KRQ1AJR15H
R701		nsp	nsp	RES.	75Ω 1/6W J	CRD20TJ750T
R702		nsp	nsp	JUMPER	SN95/PB5 , 0,6	C3A206
R703		nsp	nsp	RES.	75Ω 1/6W J	CRD20TJ750T
R704		nsp	nsp	JUMPER	SN95/PB5 , 0,6	C3A206
R705		nsp	nsp	RES.	75Ω 1/6W J	CRD20TJ750T
R706		nsp	nsp	JUMPER	SN95/PB5 , 0,6	C3A206
R707		nsp	nsp	RES.	75Ω 1/6W J	CRD20TJ750T
R708		nsp	nsp	RES.	75Ω 1/6W J	CRD20TJ750T
R709		nsp	nsp	JUMPER	SN95/PB5 , 0,6	C3A206
R710		nsp	nsp	RES.	75Ω 1/6W J	CRD20TJ750T
R711		nsp	nsp	RES.	75Ω 1/6W J	CRD20TJ750T
R712		nsp	nsp	RES.	75Ω 1/6W J	CRD20TJ750T
R713		nsp	nsp	RES.	75Ω 1/6W J	CRD20TJ750T
R714		nsp	nsp	JUMPER	SN95/PB5 , 0,6	C3A206
R715		nsp	nsp	RES.	75Ω 1/6W J	CRD20TJ750T

NOTE : *nsp* PART IS LISTED FOR REFERENCE ONLY, MARANTZ WILL NOT SUPPLY THESE PARTS.

POS. NO	VERS. COLOR	PART NO. (FOR EUR)	PART NO. (MJI)	DESCRIPTION		
R716		nsp	nsp	RES.	75Ω 1/6W J	CRD20TJ750T
R717		nsp	nsp	JUMPER	SN95/PB5 , 0.6	C3A206
R718		nsp	nsp	RES.	75Ω 1/6W J	CRD20TJ750T
R719		nsp	nsp	RES.	75Ω 1/6W J	CRD20TJ750T
R720		nsp	nsp	JUMPER	SN95/PB5 , 0.6	C3A206
R721		nsp	nsp	RES.	75Ω 1/6W J	CRD20TJ750T
R722		nsp	nsp	RES.	75Ω 1/6W J	CRD20TJ750T
R723		nsp	nsp	RES.	75Ω 1/6W J	CRD20TJ750T
R724		nsp	nsp	RES.	75Ω 1/6W J	CRD20TJ750T
R725		nsp	nsp	JUMPER	SN95/PB5 , 0.6	C3A206
R726		nsp	nsp	RES.	75Ω 1/6W J	CRD20TJ750T
R727		nsp	nsp	RES.	75Ω 1/6W J	CRD20TJ750T
R728		nsp	nsp	RES.	75Ω 1/6W J	CRD20TJ750T
R729		nsp	nsp	RES.	75Ω 1/6W J	CRD20TJ750T
R730		nsp	nsp	RES.	220 KOHM 1/5W J	CRD20TJ224T
R731		nsp	nsp	RES.	10Ω 1/6W J	CRD20TJ100T
R732		nsp	nsp	RES.	220Ω 1/6W J	CRD20TJ221T
R733		nsp	nsp	RES.	10kΩ 1/6W J	CRD20TJ103T
R734		nsp	nsp	RES.	1MΩ 1/6W J	CRD20TJ105T
R735		nsp	nsp	RES.	1MΩ 1/6W J	CRD20TJ105T
R736		nsp	nsp	RES.	100kΩ 1/6W J	CRD20TJ104T
R737		nsp	nsp	RES.	1MΩ 1/6W J	CRD20TJ105T
R738		nsp	nsp	RES.	10kΩ 1/6W J	CRD20TJ103T
R739		nsp	nsp	RES.	12kΩ 1/6W J	CRD20TJ123T
R740		nsp	nsp	RES.	470Ω 1/6W J	CRD20TJ471T
R741		nsp	nsp	RES.	75Ω 1/6W J	CRD20TJ750T
R742		nsp	nsp	RES.	75Ω 1/6W J	CRD20TJ750T
R743		nsp	nsp	RES.	75Ω 1/6W J	CRD20TJ750T
R744		nsp	nsp	RES.	220Ω 1/6W J	CRD20TJ221T
R745		nsp	nsp	JUMPER	SN95/PB5 , 0.6	C3A206
R746		nsp	nsp	RES.	1MΩ 1/6W J	CRD20TJ105T
R747	F/L/U	nsp	nsp	JUMPER	SN95/PB5 , 0.6	C3A206
R750		nsp	nsp	RES.	10kΩ 1/6W J	CRD20TJ103T
R752		nsp	nsp	RES.	75Ω 1/6W J	CRD20TJ750T
R753		nsp	nsp	RES.	220Ω 1/6W J	CRD20TJ221T
R756		nsp	nsp	JUMPER	SN95/PB5 , 0.6	C3A206
R758		nsp	nsp	RES.	4.7kΩ 1/6W J	CRD20TJ472T
R759		nsp	nsp	RES.	3.3kΩ 1/6W J	CRD20TJ332T
R761		nsp	nsp	RES.	100kΩ 1/6W J	CRD20TJ104T
R762		nsp	nsp	RES.	1MΩ 1/6W J	CRD20TJ105T
R763		nsp	nsp	RES.	3.3kΩ 1/6W J	CRD20TJ332T
R764		nsp	nsp	RES.	1MΩ 1/6W J	CRD20TJ105T
R765		nsp	nsp	RES.	1MΩ 1/6W J	CRD20TJ105T
R766		nsp	nsp	RES.	1MΩ 1/6W J	CRD20TJ105T
R767		nsp	nsp	RES.	1MΩ 1/6W J	CRD20TJ105T
R768		nsp	nsp	RES.	4.7kΩ 1/6W J	CRD20TJ472T
R769		nsp	nsp	RES.	1kΩ 1/6W J	CRD20TJ102T
R770		nsp	nsp	RES.	10kΩ 1/6W J	CRD20TJ103T
R771		nsp	nsp	RES.	56Ω 1/6W J	CRD20TJ560T
R772		nsp	nsp	RES.	1kΩ 1/6W J	CRD20TJ102T
R773		nsp	nsp	RES.	10kΩ 1/6W J	CRD20TJ103T
R774		nsp	nsp	RES.	1kΩ 1/6W J	CRD20TJ102T
R775		nsp	nsp	JUMPER	SN95/PB5 , 0.6	C3A206
R776		nsp	nsp	RES.	1MΩ 1/6W J	CRD20TJ105T
R777		nsp	nsp	RES.	1MΩ 1/6W J	CRD20TJ105T
R778		nsp	nsp	RES.	1MΩ 1/6W J	CRD20TJ105T
R781		nsp	nsp	RES.	10kΩ 1/6W J	CRD20TJ103T

NOTE : "nsp" PART IS LISTED FOR REFERENCE ONLY, MARANTZ WILL NOT SUPPLY THESE PARTS.

POS. NO	VERS. COLOR	PART NO. (FOR EUR)	PART NO. (MJJ)	DESCRIPTION		
C129		nsp	DK96103300	CER. CAP.	0.01µF	HCUS1H103KC
C130		nsp	DD91100300	CER. CAP.	10pF	HCUS1H100JA
C131		nsp	DK96102300	CER. CAP.	1000pF	HCUS1H102KB
C132		nsp	DK96103300	CER. CAP.	0.01µF	HCUS1H103KC
C133		nsp	DD95181300	CER. CAP.	180pF	HCUS1H181JA
C134		nsp	DK96103300	CER. CAP.	0.01µF	HCUS1H103KC
C135		nsp	OA10701620	ELECT. CAP.	100µF 16V	HCEA1CH101T
C136		nsp	OA47602520	ELECT. CAP.	47µF 25V	HCEA1EH470T
C137		nsp	OA10605020	ELECT. CAP.	10µF 50V	HCEA1HH100T
C138		nsp	DD95220300	CER. CAP.	22pF	HCUS1H220JA
C139		nsp	DK96103300	CER. CAP.	0.01µF	HCUS1H103KC
C140		nsp	DD91090300	CER. CAP.	9pF	CCUS1H9R0JA
C141		nsp	DD95220300	CER. CAP.	22pF	HCUS1H220JA
C142		nsp	DK96104300	CER. CAP.	0.1µF 1608 SIZE	HCUS1E104ZF
C143		nsp	DK96103300	CER. CAP.	0.01µF	HCUS1H103KC
C144		nsp	DD95220300	CER. CAP.	22pF	HCUS1H220JA
C145		nsp	DD91090300	CER. CAP.	9pF	CCUS1H9R0JA
C146		nsp	DD95220300	CER. CAP.	22pF	HCUS1H220JA
C147		nsp	DK96104300	CER. CAP.	0.1µF 1608 SIZE	HCUS1E104ZF
C148		nsp	OA10605020	ELECT. CAP.	10µF 50V	HCEA1HH100T
C149		nsp	OA10701620	ELECT. CAP.	100µF 16V	HCEA1CH101T
C150		nsp	DK96103300	CER. CAP.	0.01µF	HCUS1H103KC
C151		nsp	DK96104300	CER. CAP.	0.1µF 1608 SIZE	HCUS1E104ZF
C152		nsp	OA10605020	ELECT. CAP.	10µF 50V	HCEA1HH100T
C153	F/L/U	nsp	DD95120300	CER. CAP.	12pF	HCUS1H120JA
C153	K/N/S	nsp	DD91100300	CER. CAP.	10pF	HCUS1H100JA
C154		nsp	DD91100300	CER. CAP.	10pF	HCUS1H100JA
C155		nsp	DK96224200	CER. CAP.	0.22µF	HCUS1C224ZF
C156		nsp	DK96222300	CER. CAP.	2200pF	HCUS1H222KC
C157		nsp	DK96103300	CER. CAP.	0.01µF	HCUS1H103KC
C158		nsp	OA22505020	ELECT. CAP.	2.2µF 50V	HCEA1HH2R2T
C159		nsp	DK96104300	CER. CAP.	0.1µF 1608 SIZE	HCUS1E104ZF
C160		nsp	DK98223300	CER. CAP.	0.022µF	HCUS1H223KC
C161		nsp	OA22505020	ELECT. CAP.	2.2µF 50V	HCEA1HH2R2T
C162		nsp	OA47602520	ELECT. CAP.	47µF 25V	HCEA1EH470T
C163		nsp	DK96103300	CER. CAP.	0.01µF	HCUS1H103KC
C164		nsp	OA47602520	ELECT. CAP.	47µF 25V	HCEA1EH470T
C165		nsp	DK96103300	CER. CAP.	0.01µF	HCUS1H103KC
C166		nsp	DK96104300	CER. CAP.	0.1µF 1608 SIZE	HCUS1E104ZF
C167		nsp	DK96104300	CER. CAP.	0.1µF 1608 SIZE	HCUS1E104ZF
C168		nsp	DK96104300	CER. CAP.	0.1µF 1608 SIZE	HCUS1E104ZF
C169		nsp	DK96104300	CER. CAP.	0.1µF 1608 SIZE	HCUS1E104ZF
C170		nsp	DK96104300	CER. CAP.	0.1µF 1608 SIZE	HCUS1E104ZF
C171		nsp	DK96104300	CER. CAP.	0.1µF 1608 SIZE	HCUS1E104ZF
C172		nsp	DK96104300	CER. CAP.	0.1µF 1608 SIZE	HCUS1E104ZF
C173		nsp	DK96103300	CER. CAP.	0.01µF	HCUS1H103KC
C174		nsp	OA10701620	ELECT. CAP.	100µF 16V	HCEA1CH101T
C175		nsp	DK96102300	CER. CAP.	1000pF	HCUS1H102KB
C176		nsp	DK96104300	CER. CAP.	0.1µF 1608 SIZE	HCUS1E104ZF
C177		nsp	OA47602520	ELECT. CAP.	47µF 25V	HCEA1EH470T
C178		nsp	DK96103300	CER. CAP.	0.01µF	HCUS1H103KC
C179		nsp	DD9515030R	CER. CAP.	15pF	HCUS1H150JA
C180		nsp	DD9515030R	CER. CAP.	15pF	HCUS1H150JA
C181		nsp	OA47602520	ELECT. CAP.	47µF 25V	HCEA1EH470T
C182		nsp	DK96103300	CER. CAP.	0.01µF	HCUS1H103KC
C183		nsp	DK98473300	CER. CAP.	0.047µF	HCUS1H473ZF
C184		nsp	DK98473300	CER. CAP.	0.047µF	HCUS1H473ZF

NOTE : "nsp" PART IS LISTED FOR REFERENCE ONLY, MARANTZ WILL NOT SUPPLY THESE PARTS.

POS. NO	VERS. COLOR	PART NO. (FOR EUR)	PART NO. (MJI)	DESCRIPTION		
C185		nsp	DK96103300	CER. CAP.	0.01µF	HCUS1H103KC
C186		nsp	DK96103300	CER. CAP.	0.01µF	HCUS1H103KC
C187		nsp	DK96103300	CER. CAP.	0.01µF	HCUS1H103KC
C188		nsp	DK96103300	CER. CAP.	0.01µF	HCUS1H103KC
C189		nsp	DK96103300	CER. CAP.	0.01µF	HCUS1H103KC
C190		nsp	DK96103300	CER. CAP.	0.01µF	HCUS1H103KC
C191		nsp	DK96103300	CER. CAP.	0.01µF	HCUS1H103KC
C192		nsp	DK96103300	CER. CAP.	0.01µF	HCUS1H103KC
C193		nsp	OA47602520	ELECT. CAP.	47µF 25V	HCEA1EH470T
C194		nsp	DK96103300	CER. CAP.	0.01µF	HCUS1H103KC
C195		nsp	DK96103300	CER. CAP.	0.01µF	HCUS1H103KC
C196		nsp	OA47602520	ELECT. CAP.	47µF 25V	HCEA1EH470T
C197		nsp	DK96104300	CER. CAP.	0.1µF 1608 SIZE	HCUS1E104ZF
C198		nsp	OA10605020	ELECT. CAP.	10µF 50V	HCEA1HH100T
C199		nsp	DK96103300	CER. CAP.	0.01µF	HCUS1H103KC
C200		nsp	OA47602520	ELECT. CAP.	47µF 25V	HCEA1EH470T
C201		nsp	DK96103300	CER. CAP.	0.01µF	HCUS1H103KC
C202		nsp	DD95220300	CER. CAP.	22pF	HCUS1H220JA
C203		nsp	DD91090300	CER. CAP.	9pF	CCUS1H9R0JA
C204		nsp	DD95220300	CER. CAP.	22pF	HCUS1H220JA
C205		nsp	OA47602520	ELECT. CAP.	47µF 25V	HCEA1EH470T
C206		nsp	DK96103300	CER. CAP.	0.01µF	HCUS1H103KC
C207		nsp	DD95220300	CER. CAP.	22pF	HCUS1H220JA
C208		nsp	DD91090300	CER. CAP.	9pF	CCUS1H9R0JA
C209		nsp	DD95220300	CER. CAP.	22pF	HCUS1H220JA
C210		nsp	OA47602520	ELECT. CAP.	47µF 25V	HCEA1EH470T
C211		nsp	DK96103300	CER. CAP.	0.01µF	HCUS1H103KC
C212		nsp	DD95220300	CER. CAP.	22pF	HCUS1H220JA
C213		nsp	DD91090300	CER. CAP.	9pF	CCUS1H9R0JA
C214		nsp	DD95220300	CER. CAP.	22pF	HCUS1H220JA
C215		nsp	DK98473300	CER. CAP.	0.047µF	HCUS1H473ZF
C216		nsp	DK98473300	CER. CAP.	0.047µF	HCUS1H473ZF
C217		nsp	DK96104300	CER. CAP.	0.1µF 1608 SIZE	HCUS1E104ZF
C218		nsp	OA47602520	ELECT. CAP.	47µF 25V	HCEA1EH470T
C219		nsp	DK96104300	CER. CAP.	0.1µF 1608 SIZE	HCUS1E104ZF
C220		nsp	OA47602520	ELECT. CAP.	47µF 25V	HCEA1EH470T
C221		nsp	DK96103300	CER. CAP.	0.01µF	HCUS1H103KC
CN71		nsp	nsp	JACK	GF102-07S-TS	KJP07GA117ZG
IC11		*HC108830R	*HC108830R	IC	NJM2285M(TE1)	HVINJM2285MTE1
IC12		*HC108840R	*HC108840R	IC	SR7400	HVITC90A49F
IC13		*HC108850R	*HC108850R	IC	R59-4174	HVIMM1511XNRE
IC14		*HC108810R	*HC108810R	IC	SR7400	HVITA1270BF
IC15		*HC900040R	*HC900040R	IC REG	KIA7809AF	HVIKIA7809AF
IC16		*HC400060R	*HC400060R	IC	TC74HC4094AFN	HVITC74HC4094FN
IC18		*HC108820R	*HC108820R	IC	AK8812-T	HVIAK8812
IC19		*HC900050R	*HC900050R	IC REG	KIA78D33F	HVIKIA78D33F
L100		nsp	nsp	COIL	22µH,K	HLQ02C220KT
L101		nsp	nsp	COIL	10µH,K	HLQ02C100KT
L102		nsp	nsp	COIL	10µH,K	HLQ02C100KT
L103		nsp	nsp	COIL	10µH,K	HLQ02C100KT
L104		nsp	nsp	COIL	10µH,K	HLQ02C100KT
L105		nsp	nsp	COIL	22µH,K	HLQ02C220KT
L106		nsp	nsp	COIL	22µH,K	HLQ02C220KT
L107		nsp	nsp	COIL	10µH,K	HLQ02C100KT
L108		nsp	nsp	COIL	10µH,K	HLQ02C100KT
L109		nsp	nsp	COIL	22µH,K	HLQ02C220KT
L110		nsp	nsp	COIL	22µH,K	HLQ02C220KT

NOTE : *nsp* PART IS LISTED FOR REFERENCE ONLY, MARANTZ WILL NOT SUPPLY THESE PARTS.

POS. NO	VERS. COLOR	PART NO. (FOR EUR)	PART NO. (MJJ)	DESCRIPTION		
L111		nsp	nsp	COIL	22μH,K	HLQ02C220KT
Q100		*HT600050R	*HT600050R	TRS.	KTA2014GR	HVTKTA2014GR
Q101		*HT600050R	*HT600050R	TRS.	KTA2014GR	HVTKTA2014GR
Q102		*HT800110R	*HT800110R	TRS.	KTC4075GR	HVTKTC4075GR
Q103		*HT600050R	*HT600050R	TRS.	KTA2014GR	HVTKTA2014GR
Q104		*HT800110R	*HT800110R	TRS.	KTC4075GR	HVTKTC4075GR
Q105		*HT600050R	*HT600050R	TRS.	KTA2014GR	HVTKTA2014GR
Q106		*HT800110R	*HT800110R	TRS.	KTC4075GR	HVTKTC4075GR
Q107		*HT600050R	*HT600050R	TRS.	KTA2014GR	HVTKTA2014GR
Q108		*HT800110R	*HT800110R	TRS.	KTC4075GR	HVTKTC4075GR
Q109		*HT600050R	*HT600050R	TRS.	KTA2014GR	HVTKTA2014GR
Q110		*HT800110R	*HT800110R	TRS.	KTC4075GR	HVTKTC4075GR
Q111		*HT600050R	*HT600050R	TRS.	KTA2014GR	HVTKTA2014GR
Q112		*HT800110R	*HT800110R	TRS.	KTC4075GR	HVTKTC4075GR
Q113		*HT600050R	*HT600050R	TRS.	KTA2014GR	HVTKTA2014GR
Q114		*HT800110R	*HT800110R	TRS.	KTC4075GR	HVTKTC4075GR
Q115		*HT600050R	*HT600050R	TRS.	KTA2014GR	HVTKTA2014GR
Q116		*HT800110R	*HT800110R	TRS.	KTC4075GR	HVTKTC4075GR
Q117		*HT600050R	*HT600050R	TRS.	KTA2014GR	HVTKTA2014GR
Q118		*HX800010R	*HX800010R	CHIP TR.	KRC102S	HVTKRC102S
Q119		*HX800010R	*HX800010R	CHIP TR.	KRC102S	HVTKRC102S
Q120		*HT800110R	*HT800110R	TRS.	KTC4075GR	HVTKTC4075GR
R100		nsp	NN05102610	CHIP RES.	1kΩ	HRJ10DJ102T
R101		nsp	NN05821610	CHIP RES.	820Ω	HRJ10DJ821T
R102		nsp	NN05102610	CHIP RES.	1kΩ	HRJ10DJ102T
R103		nsp	NN05152610	CHIP RES.	1.5kΩ	HRJ10DJ152T
R104		nsp	NN05102610	CHIP RES.	1kΩ	HRJ10DJ102T
R105		nsp	NN05821610	CHIP RES.	820Ω	HRJ10DJ821T
R106		nsp	NN05102610	CHIP RES.	1kΩ	HRJ10DJ102T
R107		nsp	NN05152610	CHIP RES.	1.5kΩ	HRJ10DJ152T
R108		nsp	NN05105610	CHIP RES.	1MΩ	HRJ10DJ105T
R109		nsp	NN05105610	CHIP RES.	1MΩ	HRJ10DJ105T
R110		nsp	NN05105610	CHIP RES.	1MΩ	HRJ10DJ105T
R111		nsp	NN05105610	CHIP RES.	1MΩ	HRJ10DJ105T
R112		nsp	NN05224610	CHIP RES.	220kΩ	HRJ10DJ224T
R113		nsp	NN05222610	CHIP RES.	2.2kΩ	HRJ10DJ222T
R114		nsp	NN05102610	CHIP RES.	1kΩ	HRJ10DJ102T
R115		nsp	NN05102610	CHIP RES.	1kΩ	HRJ10DJ102T
R116		nsp	NN05222610	CHIP RES.	2.2kΩ	HRJ10DJ222T
R117		nsp	NN05472610	CHIP RES.	4.7kΩ	HRJ10DJ472T
R118		nsp	NN05101610	CHIP RES.	100Ω	HRJ10DJ101T
R119		nsp	NN05821610	CHIP RES.	820Ω	HRJ10DJ821T
R120		nsp	NN05123610	CHIP RES.	12kΩ	HRJ10DJ123T
R121		nsp	NN05103610	CHIP RES.	10kΩ	HRJ10DJ103T
R122		nsp	NN05471610	CHIP RES.	470Ω	HRJ10DJ471T
R123		nsp	NN05471610	CHIP RES.	470Ω	HRJ10DJ471T
R124		nsp	NN05471610	CHIP RES.	470Ω	HRJ10DJ471T
R125		nsp	NN05103610	CHIP RES.	10kΩ	HRJ10DJ103T
R126		nsp	NN05102610	CHIP RES.	1kΩ	HRJ10DJ102T
R127		nsp	NN05102610	CHIP RES.	1kΩ	HRJ10DJ102T
R128		nsp	NN05471610	CHIP RES.	470Ω	HRJ10DJ471T
R129		nsp	NN05471610	CHIP RES.	470Ω	HRJ10DJ471T
R130		nsp	NN05471610	CHIP RES.	470Ω	HRJ10DJ471T
R131		nsp	NN05103610	CHIP RES.	10kΩ	HRJ10DJ103T
R132		nsp	NN05123610	CHIP RES.	12kΩ	HRJ10DJ123T
R133		nsp	NN05103610	CHIP RES.	10kΩ	HRJ10DJ103T
R134		nsp	NN05471610	CHIP RES.	470Ω	HRJ10DJ471T

NOTE : "nsp" PART IS LISTED FOR REFERENCE ONLY, MARANTZ WILL NOT SUPPLY THESE PARTS.

POS. NO	VERS. COLOR	PART NO. (FOR EUR)	PART NO. (MJI)	DESCRIPTION		
R135		nsp	NN05471610	CHIP RES.	470Ω	HRJ10DJ471T
R136		nsp	NN05471610	CHIP RES.	470Ω	HRJ10DJ471T
R137		nsp	NN05103610	CHIP RES.	10kΩ	HRJ10DJ103T
R138		nsp	NN05102610	CHIP RES.	1kΩ	HRJ10DJ102T
R139		nsp	NN05102610	CHIP RES.	1kΩ	HRJ10DJ102T
R140		nsp	NN05471610	CHIP RES.	470Ω	HRJ10DJ471T
R141		nsp	NN05471610	CHIP RES.	470Ω	HRJ10DJ471T
R142		nsp	NN05471610	CHIP RES.	470Ω	HRJ10DJ471T
R143		nsp	NN05103610	CHIP RES.	10kΩ	HRJ10DJ103T
R144		nsp	NN05333610	CHIP RES.	33kΩ	HRJ10DJ333T
R145		nsp	NN05332610	CHIP RES.	3.3kΩ	HRJ10DJ332T
R146		nsp	NN05331610	CHIP RES.	330Ω	HRJ10DJ331T
R147		nsp	NN05101610	CHIP RES.	100Ω	HRJ10DJ101T
R148		nsp	NN05472610	CHIP RES.	4.7kΩ	HRJ10DJ472T
R149		nsp	NN05101610	CHIP RES.	100Ω	HRJ10DJ101T
R150		nsp	NN05101610	CHIP RES.	100Ω	HRJ10DJ101T
R151		nsp	NN05101610	CHIP RES.	100Ω	HRJ10DJ101T
R152		nsp	NN05330610	CHIP RES.	33Ω	HRJ10DJ330T
R153		nsp	NN05330610	CHIP RES.	33Ω	HRJ10DJ330T
R154		nsp	NN05330610	CHIP RES.	33Ω	HRJ10DJ330T
R155		nsp	NN05330610	CHIP RES.	33Ω	HRJ10DJ330T
R156		nsp	NN05330610	CHIP RES.	33Ω	HRJ10DJ330T
R157		nsp	NN05330610	CHIP RES.	33Ω	HRJ10DJ330T
R158		nsp	NN05330610	CHIP RES.	33Ω	HRJ10DJ330T
R159		nsp	NN05330610	CHIP RES.	33Ω	HRJ10DJ330T
R160		nsp	NN05330610	CHIP RES.	33Ω	HRJ10DJ330T
R161		nsp	NN05101610	CHIP RES.	100Ω	HRJ10DJ101T
R162		nsp	NN05682610	CHIP RES.	6.8kΩ	HRJ10DJ682T
R163		nsp	NN05101610	CHIP RES.	100Ω	HRJ10DJ101T
R164		nsp	NN05682610	CHIP RES.	6.8kΩ	HRJ10DJ682T
R165		nsp	NN05332610	CHIP RES.	3.3kΩ	HRJ10DJ332T
R166		nsp	NN05332610	CHIP RES.	3.3kΩ	HRJ10DJ332T
R167		nsp	NN05103610	CHIP RES.	10kΩ	HRJ10DJ103T
R168		nsp	NN05123610	CHIP RES.	12kΩ	HRJ10DJ123T
R169		nsp	NN05000610	CHIP RES.	0Ω	HRJ10DJ0R0T
R170		nsp	NN05391610	CHIP RES.	390Ω	HRJ10DJ391T
R171		nsp	NN05183610	CHIP RES.	18kΩ	HRJ10DJ183T
R172		nsp	NN05103610	CHIP RES.	10kΩ	HRJ10DJ103T
R173		nsp	NN05471610	CHIP RES.	470Ω	HRJ10DJ471T
R174		nsp	NN05471610	CHIP RES.	470Ω	HRJ10DJ471T
R175		nsp	NN05471610	CHIP RES.	470Ω	HRJ10DJ471T
R176		nsp	NN05103610	CHIP RES.	10kΩ	HRJ10DJ103T
R177		nsp	NN05102610	CHIP RES.	1kΩ	HRJ10DJ102T
R178		nsp	NN05102610	CHIP RES.	1kΩ	HRJ10DJ102T
R179		nsp	NN05391610	CHIP RES.	390Ω	HRJ10DJ391T
R180		nsp	NN05183610	CHIP RES.	18kΩ	HRJ10DJ183T
R181		nsp	NN05103610	CHIP RES.	10kΩ	HRJ10DJ103T
R182		nsp	NN05471610	CHIP RES.	470Ω	HRJ10DJ471T
R183		nsp	NN05471610	CHIP RES.	470Ω	HRJ10DJ471T
R184		nsp	NN05471610	CHIP RES.	470Ω	HRJ10DJ471T
R185		nsp	NN05103610	CHIP RES.	10kΩ	HRJ10DJ103T
R186		nsp	NN05102610	CHIP RES.	1kΩ	HRJ10DJ102T
R187		nsp	NN05102610	CHIP RES.	1kΩ	HRJ10DJ102T
R188		nsp	NN05391610	CHIP RES.	390Ω	HRJ10DJ391T
R189		nsp	NN05183610	CHIP RES.	18kΩ	HRJ10DJ183T
R190		nsp	NN05103610	CHIP RES.	10kΩ	HRJ10DJ103T
R191		nsp	NN05471610	CHIP RES.	470Ω	HRJ10DJ471T

NOTE : *nsp* PART IS LISTED FOR REFERENCE ONLY, MARANTZ WILL NOT SUPPLY THESE PARTS.

